

PARTS AND REPAIR MANUAL

Ariens

8HP

Lawn Tractor

929000 Series

THIS MANUAL COVERS
THE COMPLETE LINE OF
ARIENS 929000 SERIES
LAWN TRACTORS MODELS
1974 THROUGH 1978
INCLUSIVE.

PRM 29000

1974 THROUGH 1978 INCLUSIVE

ARIENS COMPANY



BRILLION, WIS. 54110

INDEX

929000 LAWN TRACTOR

1974 THROUGH 1978

MODEL NUMBER and SERIAL NUMBER of your machine will be stamped on the frame or printed on the Serial Number Decal which will be located on the frame near the engine on all Ariens products. Do not be confused with other identification plates located on the engine or attachments.



1. EXPLODED VIEW AND PARTS LIST 3

MODEL NO.	SERIAL NO.	YEAR	PAGE NO.
929001	000301 - 001708	1974/76	27 through 45
929001	001709 & Up	1977/78	3 through 21
929002	000301 - 002779	1974/76	27 through 45
929002	002780 & Up	1977/78	3 through 21
ATTACHMENTS			
829001	000301 - 003739 — 36" Mower		46 and 47
829001	003740 & Up — 36" Mower		22 and 23
829002	NONE — Front Blade		24 and 25
829003	000101 & Up — 36" Sno Thro		48 and 49
729005	NONE — Headlight Kit		26

2. ASSEMBLY 50

3. CONTROLS 52

4. OPERATION 55

5. LUBRICATION 57

6. MAINTENANCE 59

7. SERVICE & ADJUSTMENTS 62

36 RM ROTARY MOWER 67

IMPROVEMENT PACKAGES 70

8. TROUBLESHOOTING 73

9. BELT CROSS REFERENCE 78

10. ENGINE CROSS REFERENCE 78

11. 36" SNO-THRO ATTACHMENT 79

ASSEMBLY 79

INSTALLATION 80

CONTROL & OPERATION 81

ADJUSTMENTS 82

LUBRICATION 83

TROUBLESHOOTING 83

MUFFLER, FUEL LINES & TANK

SILENCIEUX - CANALISATIONS DE CARBURANT - RÉSERVOIR

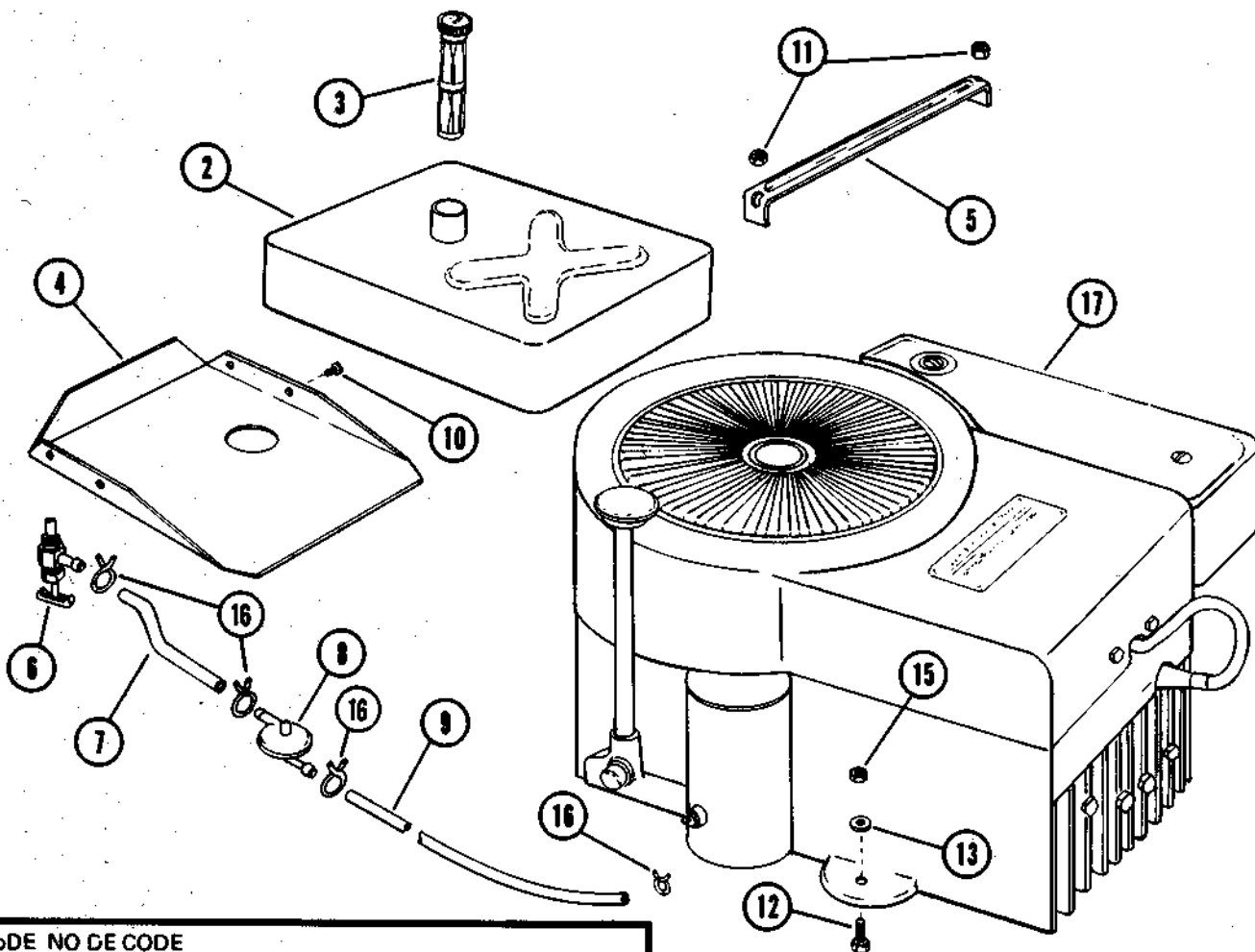

NO DE REF.	NO DE PIECE	CODE D'INV	DESCRIPTION	QUANTITE	NO. REQ'D
REF. NO.	PART NO.	STOCK CODE			929001 929002

2	029162	M	FUEL TANK	1	1
3	029110	M	GUAGE	1	1
4	029114	O	BRACE	1	1
5	029115	S	STRAP	1	1
6	031536	M	VALVE, Shut-Off	1	1
7	029113	M	HOSE, 4" long, 1/4" ID	1	1
8	029108	M	FUEL FILTER	1	1
9	029112	M	HOSE, 8-3/4" long, 1/4" ID	1	1
10	070099	M	FLANGE WHIZLOCK SCREW	4	4
11	065070	M	LOCKNUT, Hex, 1/4" - 20	2	2
12	059140	M	CAP SCREW, HH, 5/16" - 18	4	4
			x 1-1/2" Grade 5	4	4
13	064123	M	WASHER, Flat, 5/16"	4	4
15	065124	M	NUT, Hex, 5/16" - 18 Grade C	4	4
16	029172	M	CLIP	4	4
17			ENGINE BRIGGS *191707 Type	1	1

0636 Order Replacement Engine
and or Engine Replacement Parts
From Respective Engine Manufacturer.

CODE SUGGERÉ D'INVENTAIRE DES PIÈCES

F - FAST (rapide) S - SLOW (lent)
M - MEDIUM (moyen) O - Commande du client seulement

SUGGESTED PARTS STOCKING CODE

F - FAST S - SLOW
M - MEDIUM O - CUSTOMER ORDER ONLY

FRAME, STEERING, FRONT AXLE, FRONT WHEEL & SPINDLE CHÂSSIS-DIRECTION-ESSIEU AVANT-ROUE AVANT ET FUSÉE

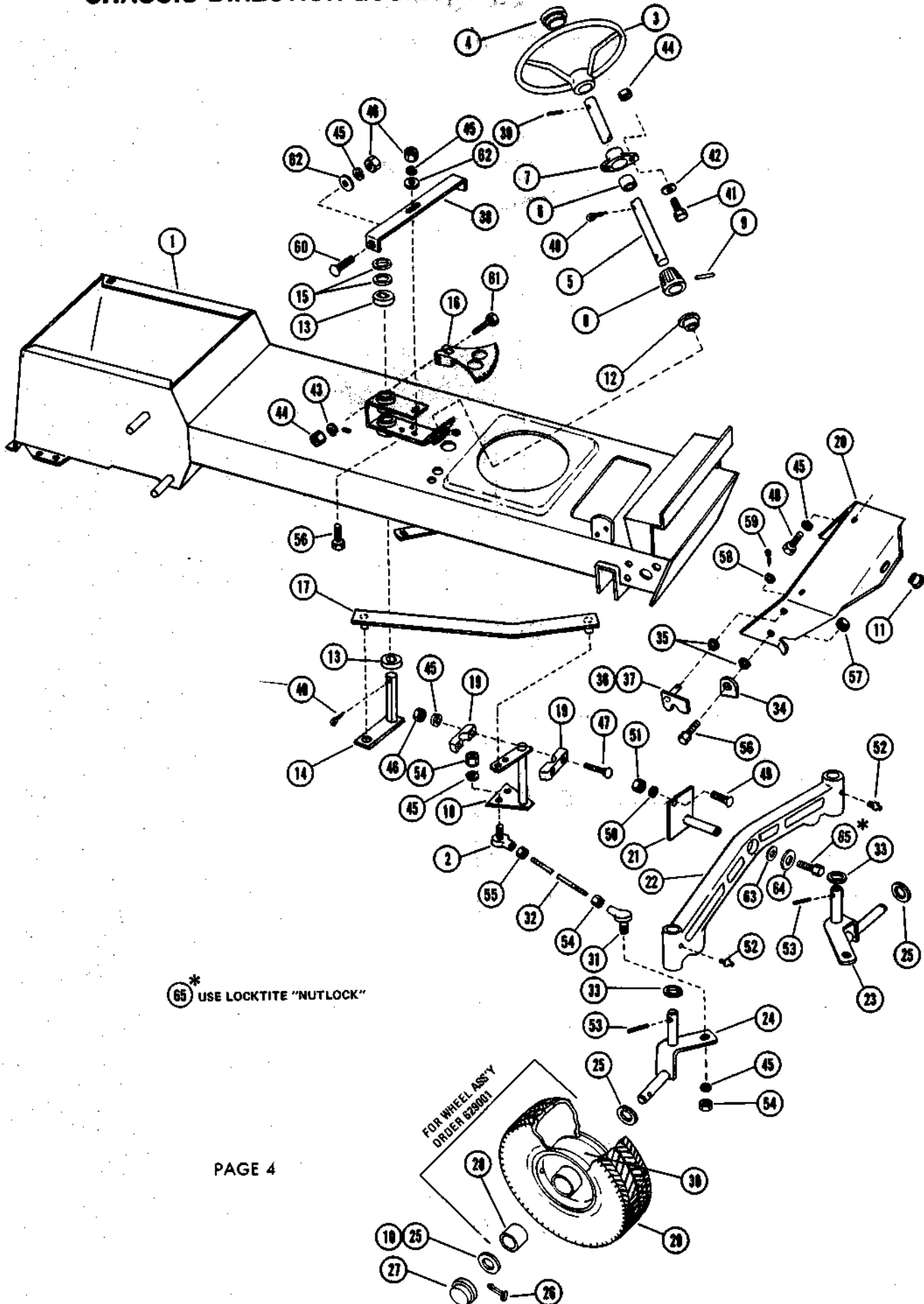

65* USE LOCKTITE "NUTLOCK"

FOR WHEEL ASSY
ORDER B22001

FRAME, STEERING, FRONT AXLE, FRONT WHEEL & SPINDLE

CHÂSSIS-DIRECTION-ESSIEU AVANT-ROUE AVANT ET FUSÉE

NoDE NO DE CODE				QUANTITÉ		NoDE No DE CODE				QUANTITÉ	
REF.	PART	STOCK	DESCRIPTION	NO. REQ'D		REF.	PART	STOCK	DESCRIPTION	NO. REQ'D	
NO.	NO.	CODE		929001	929002	NO.	NO.	CODE		929001	929002
1	029002	O	FRAME, Gear	1		33	075059	M	WASHER, Thrust	2	2
	529009	O	FRAME, Hydrostatic		1	34	029013	S	LOCK STRIP	2	2
2	029158	F	L.H. BALL JOINT	2	2	35	029024	M	WASHER, Spring	4	4
3	629007	S	STEERING WHEEL W/Cap	1	1	36	029015	S	LATCH, L.H.	1	1
4	029163	S	CAP	1	1	37	029014	S	LATCH, R.H.	1	1
5	029020	S	STEERING COLUMN	1	1	38	029018	S	BRACKET	1	1
6	029023	S	SPACER	1	1	39	058004	M	PIN, Spring, 1/4" x 1-1/2"	1	1
7	054025	M	BEARING, Side Flange	1	1	40	067006	M	PIN, Cotter, 3/16" x 1-1/4"	2	2
8	029021	S	PINION GEAR	1	1	41	059003	M	CAP SCREW, HH, 5/16" - 18 x 1	2	2
9	029133	M	NEEDLE ROLLER	1	1	42	064002	M	WASHER, Flat, 5/16"	2	2
10	064095	M	WASHER, Special	3	(AR)3	43	063003	M	LOCKWASHER, 5/16"	4	4
11	055076	F	BUSHING' Nylon	1	1	44	065015	M	NUT, Hex, 5/16" - 18	4	4
12	055080	F	BUSHING	1	1	45	063021	M	LOCKWASHER, 3/8"	13	13
13	055083	F	BUSHING, Hex Bore	2	2	46	065018	M	NUT, Hex, 3/8" - 16	7	7
14	029017	M	ARM & SHAFT	1	1	47	062005	M	BOLT, Carriage, 3/8" - 16 x 2-1/2"	4	4
15	064111	M	WASHER, 7/8" I.D. x 1-1/4" O.D.	2	2	48	059133	M	CAP SCREW, HH, 3/8" - 16 x 1-1/4" 2 Grade 5	2	2
16	029019	S	BEVEL GEAR SEGMENT	1	1	49	062012	M	BOLT, Carriage, 1/4" - 20 x 3/4"	1	1
17	029012	S	LINK	1	1	50	063002	M	LOCKWASHER, 1/4"	1	1
18	029010	S	CRANK	1	1	51	065032	M	NUT, Hex, 1/4" - 20	1	1
19	029011	M	BLOCK	4	4	52	022093	F	FITTING, Grease	2	2
20	029007	O	MOUNTING, Front	1	1	53	058050	M	PIN, Grooved, 1/4" x 1-1/4" Type E	2	2
21	029006	M	AXLE PIVOT	1	1	54	065005	M	NUT, Hex, 3/8" x 24 UNF.	6	6
22	029005	M	AXLE, Front	1	1	55	065073	M	NUT, Hex, 3/8" - 24 UNF L.H.	2	2
23	029008	M	SPINDLE, L.H.	1	1	56	059004	M	CAP SCREW, HH, 3/8" - 16 x 1"	3	3
24	029009	M	SPINDLE, R.H.	1	1	57	065039	M	LOCKNUT, Hex, 3/8" - 16	2	2
25	064109	M	WASHER, Special	4	4	58	064043	M	WASHER, Flat, 3/8"	4	(AR)4
26	067027	M	COTTER, "T" Head	2	2	59	067024	M	PIN, Cotter, 1/8" x 3/4"	2	2
27	029173	M	GREASE CAP	2	2	60	062029	M	BOLT, Carriage, 3/8" - 16 x 1"	2	2
	629001	O	WHEEL ASS'Y (Consists of)	2	2	61	059128	M	CAP SCREW, HH, 5/16" - 18 x 1-3/4" Grade 5	2	2
28	055086	M	BUSHING	2	2	62	064008	M	WASHER, Flat, 3/8"	3	3
29	071099	S	TIRE, 15 x 6.00	1	1	63	064041	M	WASHER	1	1
30	071100	S	WHEEL	1	1	64	064102	M	WASHER	1	1
31	029171	F	BALL JOINT, R.H.	2	2	65	059004	M	CAP SCREW	1	1
32	029016	M	TIE ROD	2	2						

SUGGESTED PARTS STOCKING CODE

F - FAST
M - MEDIUM
S - SLOW
O - CUSTOMER ORDER ONLY

CODE SUGGÉRÉ D'INVENTAIRE DES PIÈCES

F - FAST (rapide)
M - MEDIUM (moyen)
S - SLOW (lent)
O - Commande du client seulement

HOOD, REAR DECK, SEAT, DASH SUPPORT, RUNNING BOARD
CAPOT AVANT-CAPOT ARRIÈRE-SIÈGE-SUPPORT DE TABLEAU
DE BORD REPOSE-PIED

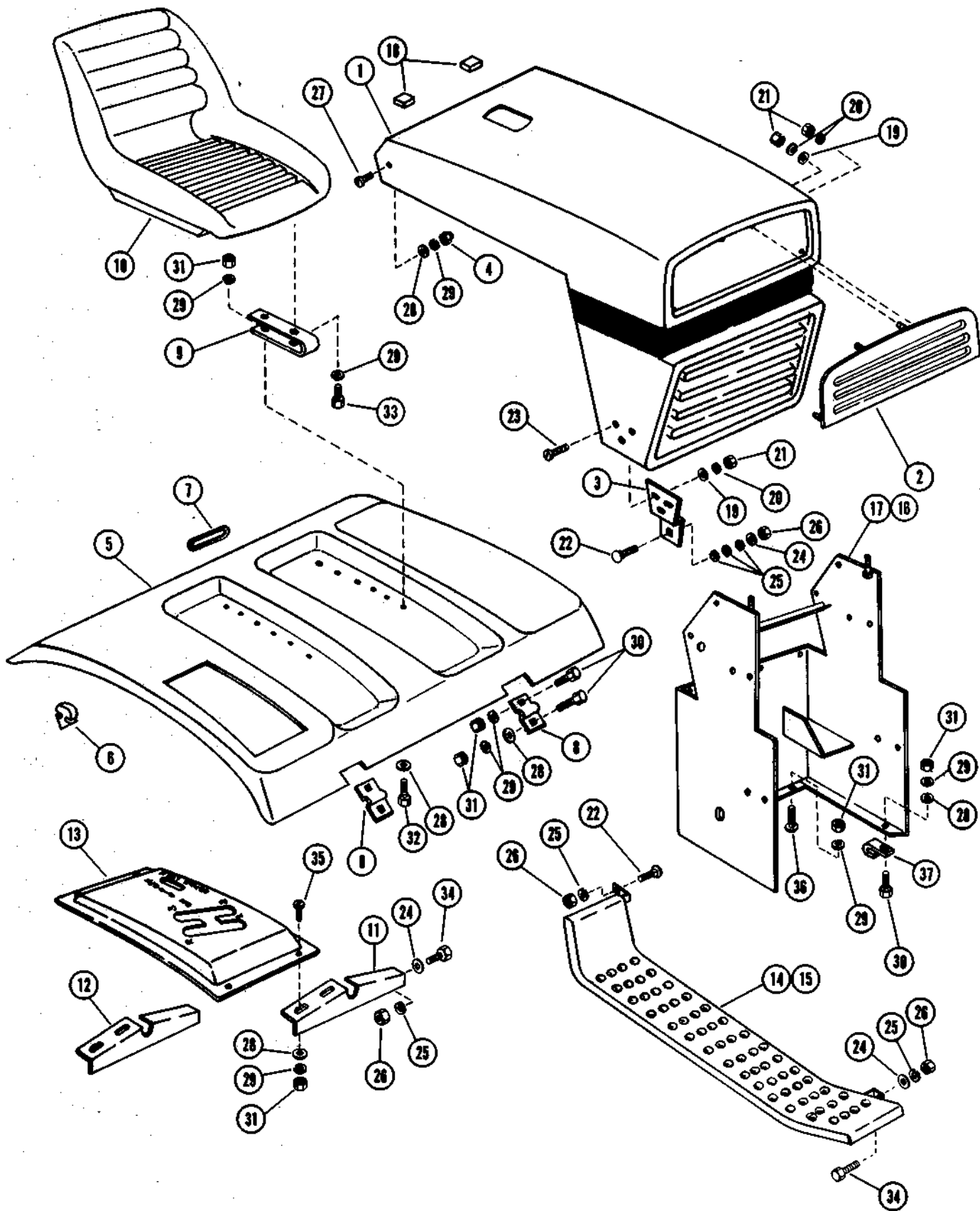

HOOD, REAR DECK, SEAT, DASH SUPPORT, RUNNING BOARD

CAPOT AVANT-CAPOT ARRIÈRE-SIÈGE-SUPPORT DE TABLEAU DE BORD REPOSE-PIED

NoDE REF.	NO DE CODE PIECÉ D'INV PART STOCK	DESCRIPTION	QUANTITÉ NO. REQ'D 929001 929002	NoDE REF.	NO DE CODE PIECÉ D'INV. PART STOCK	DESCRIPTION	QUANTITÉ NO. REQ'D 929001 929002
1	529007 O	HOOD (Gear)	1	21	065032 M	NUT, Hex, 1/4" - 20	10 10
	529008 O	HOOD (Hydro)	1	22	062029 M	BOLT, Carriage, 3/8" - 16 x 1"	6 6
2	029124 O	GRILL INSERT	1 1	23	061041 M	SCREW, Machine, 1/4" - 20 x 5/8"	6 6
3	029122 S	HINGE, Hood	2 2	24	064008 M	WASHER, Flat, 3/8"	10 10
4	065095 M	NUT, Crown 5/16" - 18	2 2	25	063021 M	LOCKWASHER, 3/8"	18 18
5	029119 O	REAR DECK	1 1	26	065018 M	NUT, Hex, 3/8" - 16	14 14
6	075054 M	BUMPER, Rubber	2 2	27	061045 M	SCREW, Machine, 5/16" - 18 x 1/2"	2 2
7	029134 M	REFLECTOR, Tail	1 1	28	064002 M	WASHER, Flat, 5/16"	14 14
8	029123 M	HINGE	2 2	29	063003 M	LOCKWASHER, 5/16	22 22
9	029038 S	SPRING	2 2	30	059022 M	CAP SCREW, HH, 5/16" - 18 x 3/4"	6 6
10	029127 F	SEAT	1 1	31	065015 M	NUT, Hex, 5/16" - 18	16 16
11	029107 S	SUPPORT, Front	1 1	32	059003 M	CAP SCREW, HH, 5/16" - 18 x 1"	4 4
12	029106 S	SUPPORT, Rear	1 1	33	059135 M	CAP SCREW, HH, 5/16" x 18 x 3/4" Grade 5	4 4
13	029120 O	CONSOLE, (Gear)	1	34	059004 M	CAP SCREW, HH, 3/8" - 16 x 1"	8 8
	029121 O	CONSOLE (Hydrostatic)	1	35	061042 M	SCREW, Machine, 5/16" - 18 x 3/4"	4 4
14	029254 S	RUNNING BOARD, L.H.	1 1	36	062011 M	BOLT, Carriage, 5/16" - 18 x 3/4"	2 2
15	029253 S	RUNNING BOARD, R.H.	1 1	37	69094 M	J-CLAMP	1 1
16	529006 O	BASE (Gear)	1				
17	529005 O	BASE (Hydro)	1				
18	075058 M	STOP (Pressure Sensitive Backing)	2 2				
19	064007 M	WASHER, Flat, 1/4"	8 8				
20	063002 M	LOCKWASHER, 1/4"	10 10				

SUGGESTED PARTS STOCKING CODE

F - FAST
M - MEDIUM
S - SLOW
O - CUSTOMER ORDER ONLY

CODE SUGGÉRÉ D'INVENTAIRE DES PIÈCES

F - FAST (rapide)
M - MEDIUM (moyen)
S - SLOW (lent)
O - Commande du client seulement

REAR WHEELS & AXLE, BELT & DRIVE-HYDROSTATIC ROUES ARRIÈRE - ESSIEU, COURROIE, TRANSMISSION - MODÈLES HYDROSTATIQUES

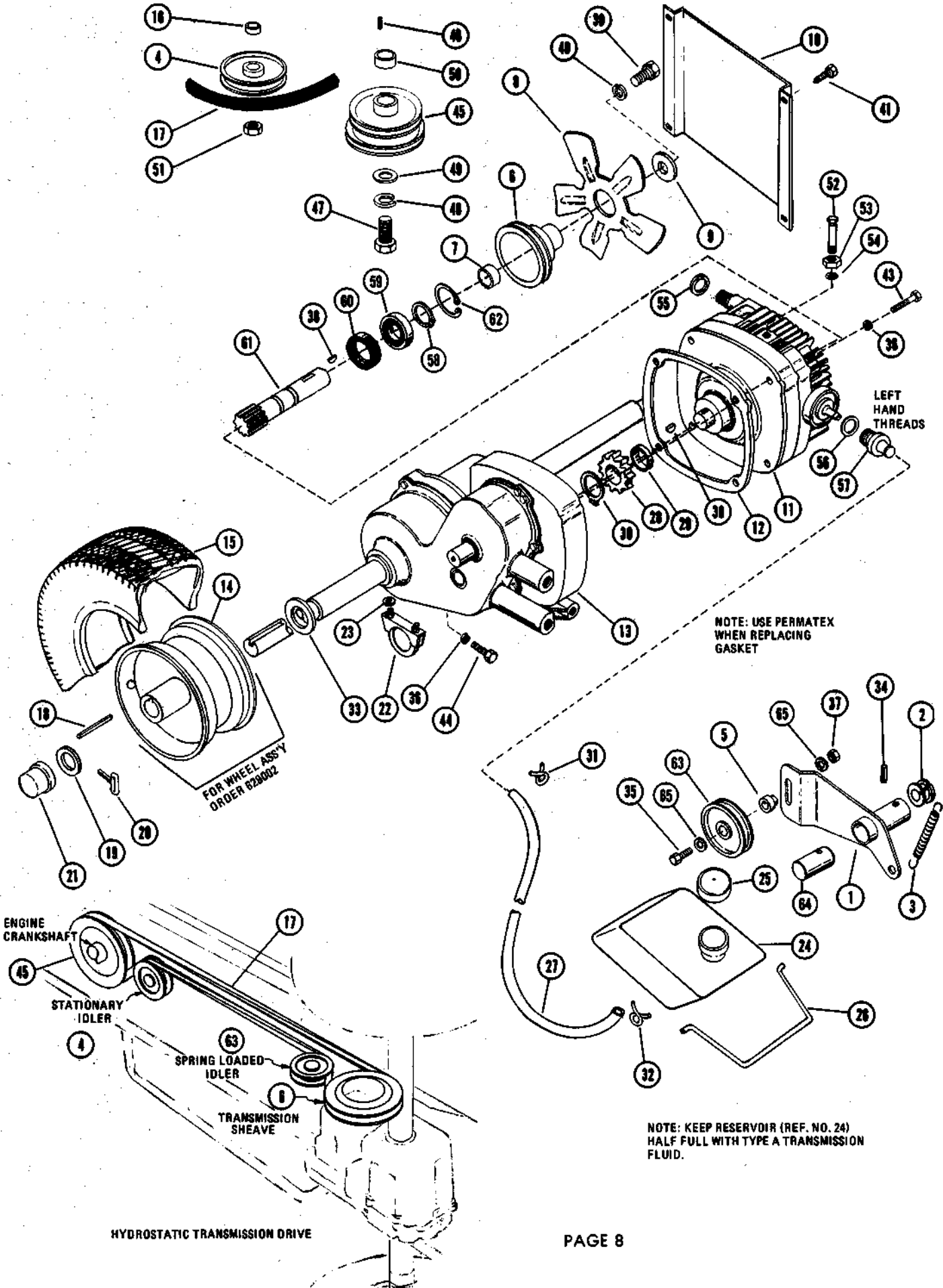

REAR WHEELS & AXLE, BELT & DRIVE-HYDROSTATIC

ROUES ARRIÈRE - ESSIEU, COURROIE, TRANSMISSION - MODÈLES HYDROSTATIQUES

NoDE REF.	NO DE CODE PIECÉ D'INV PART STOCK NO. NO. CODE	DESCRIPTION	QUANTITÉ NO. REQ'D 929002	NoDE REF.	NO DE CODE PIECÉ D'INV. PART STOCK NO. NO. CODE	DESCRIPTION	QUANTITÉ NO. REQ'D 929002
1	029265 M	IDLER ARM	1	41	070009 M	FLANGE WHIZ LOCK SCREW	4
2	055077 M	BEARING, Nylon	2	43	059141 M	CAP SCREW, HH, 3/8" - 16 x 3" Grade 5	4
3	083111 M	SPRING	1	44	059023 M	CAP SCREW, HH 3/8" - 16 x 3/4"	2
4	073054 F	IDLER	1	45	029105 S	SHEAVE	1
5	010360 M	SPACER	1	46	066026 M	KEY, Square, 1/4" x 1/4" x 2-1/2"	1
6	029041 S	SHEAVE	1	47	059142 M	CAP SCREW, HH, 7/16" - 20 x 1"	1
7	029142 M	SPACER	1	48	063005 M	LOCKWASHER, 7/16"	1
8	029043 F	FAN	1	49	064047 M	WASHER, Special	1
9	064099 M	WASHER, Special	1	50	029139 S	SPACER	1
10	029042 O	SHIELD	1	51	065039 M	LOCKNUT, 3/8" - 16	1
† 11	629010 S	DRIVE ASS'Y HYDROSTATIC	1	52	029217 M	DUMP VALVE	1
12	029044 F	GASKET	1	53	029215 M	NUT, W/Gasket	1
* 13		TRANSMISSION (Tecumseh No. 1309)	1	54	056078 F	"O" RING	1
	629002 O	WHEEL ASS'Y, Rear Consists of:	2	55	056079 F	OIL SEAL	1
14		071102 RIM	1	56	029216 F	GASKET	1
15		071101 TIRE, 20 x 8.00-10	1	57	029214 M	ADAPTOR	1
16	029160 S	SPACER	1	58	057072 M	SNAP RING	1
17	072102 F	"V" BELT (Hydrostatic)	1	59	054071 M	BEARING	1
18	066018 M	KEY, Square, 1/4" x 1/4" x 1-3/4"	2	60	056095 F	SEAL	1
19	064029 M	WASHER, Special	2	61	529014 S	INPUT SHAFT W/BEARING & SNAP RING	1
20	067027 M	COTTER, "T" Head	2	62	057071 M	SNAP RING	1
21	029173 M	CAP, Grease	2	63	012132 M	IDLER	1
22	023077 M	"U" BOLT & CLAMP ASS'Y	2	64	029264 S	PIVOT PIN	1
23	064002 M	WASHER, Flat, 5/16"	2	65	064123 M	WASHER	2
24	029045 S	RESERVOIR, Oil	1				
25	029001 S	CAP	1				
26	029138 M	CLIP	1				
27	029135 M	HOSE	1				
28	029046 S	SPUR GEAR	1				
29	029143 S	SPACER	1				
30	057061 M	RING, Retaining	1				
31	057052 M	CLAMP, Spring	1				
32	069096 M	CLAMP, Spring	1				
33	064110 M	WASHER	2				
34	058016 M	ROLL PIN, 3/16" x 1"	1				
35	059140 M	CAPSCREW, H.H. 5/16" - 18 x 1-1/2 Grade 5	1				
36	063021 M	LOCKWASHER, 3/8"	6				
37	065042 M	LOCKNUT, 5/16" - 18	1				
38	066006 M	KEY, Woodruff, No. 3	2				
39	059132 M	CAP SCREW, HH, 1/4" - 20 x 1	1				
40	063002 M	LOCKWASHER, 1/4"	1				

SUGGESTED PARTS STOCKING CODE

F - FAST S - SLOW
M - MEDIUM O - CUSTOMER ORDER ONLY

CODE SUGGÉRÉ D'INVENTAIRE DES PIÈCES

F - FAST (rapide) S - SLOW (lent)
M - MEDIUM (moyen) O - Commande du client seulement

*The transmission is to be serviced and warranted by Tecumseh Products.

† Assembly includes Ref. No. 52 thru 62

REAR WHEELS & AXLE, BELT & DRIVE -GEAR

ROUES ARRIÈRE - ESSIEU, COURROIE, TRANSMISSION - MODÈLES MÉCANIQUES

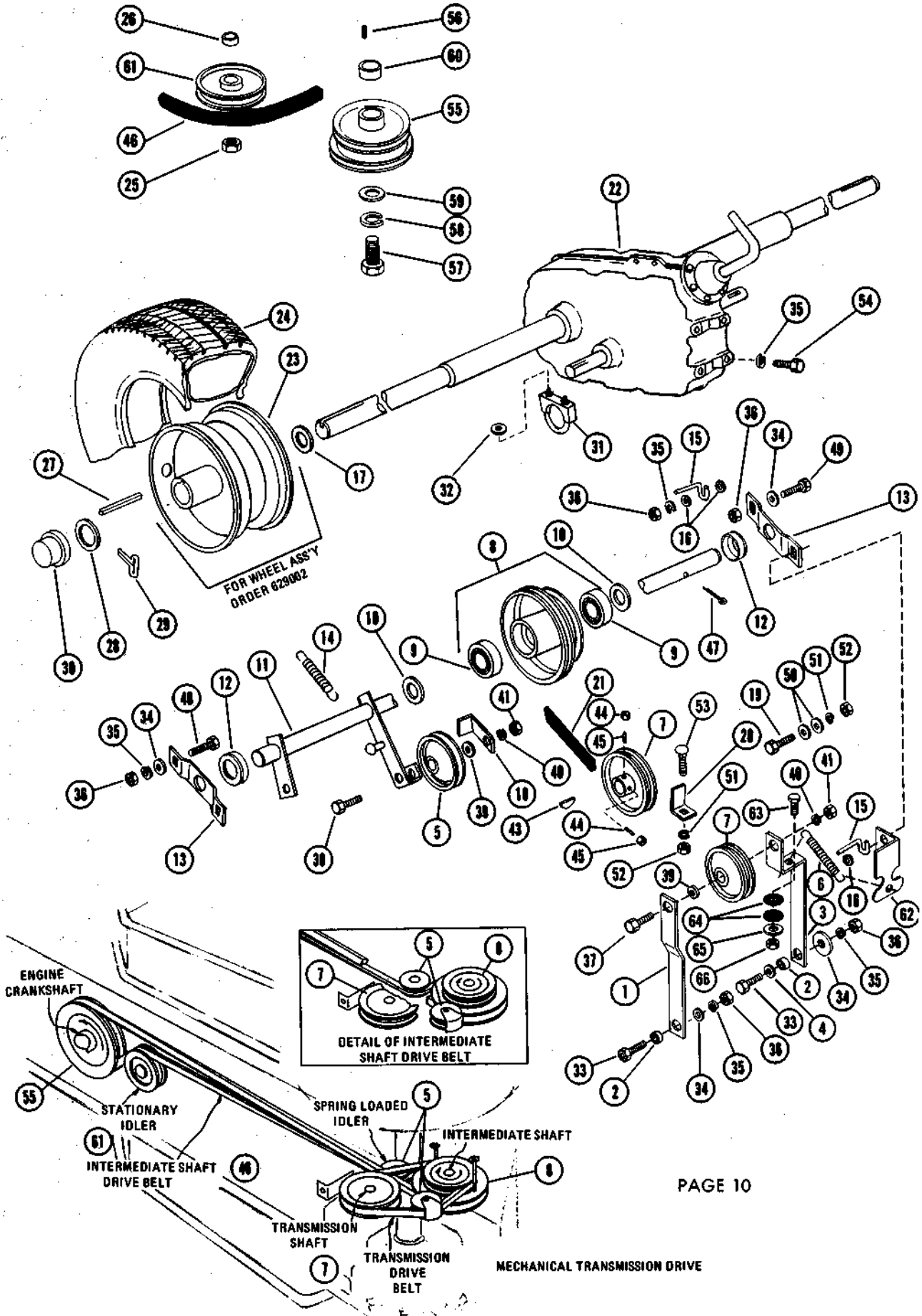

REAR WHEELS & AXLE, BELT & DRIVE -GEAR

ROUES ARRIÈRE - ESSIEU, COURROIE, TRANSMISSION - MODÈLES MÉCANIQUES

NoDE REF.	NO DE PIECÉ D'INV	CODE	DESCRIPTION	QUANTITÉ	NoDE REF.	NO DE PIECÉ D'INV.	CODE	DESCRIPTION	QUANTITÉ
REF. NO.	PART NO.	STOCK CODE		NO. REQ'D 929001	REF. NO.	PART NO.	STOCK CODE		NO. REQ'D 929001
1	029028	S	IDLER ARM	1	33	059005	M	CAP SCREW, HH, 3/8" - 16 x 1-1/4"	2
2	029140	S	SPACER	2	34	064008	M	WASHER, Flat, 3/8"	6
3	029029	S	IDLER ARM	1	35	063021	M	LOCKWASHER, 3/8"	8
4	064101	M	WASHER, Special	1	36	065018	M	NUT, Hex, 3/8" - 16	8
5	073101	M	IDLER	2	37	059143	M	CAP SCREW, HH, 1/2" x 2-1/4" Gr. 5	1
6	083110	M	SPRING	1	38	059058	M	CAP SCREW, HH, 1/2" - 13 x 3-1/4" Grade 5	1
7	073064	M	SHEAVE	1					
8	629003	S	SHEAVE W/Ball Bearing	1	39	064120	M	WASHER, Flat, 1/2"	2
9	054073	M	BALL BEARING	2	40	063006	M	LOCKWASHER, 1/2"	2
10	064108	M	SPACER, Washer	3 (AR)	41	065021	M	NUT, Hex, 1/2" - 13	2
11	029034	S	IDLER PIVOT	1	43	066003	M	KEY, Woodruff, No. 9	1
12	055077	F	BEARING, Nylon	2	44	060030	M	SCREW, Hex Socket, 1/4" - 20 x 5/8"	2
13	029035	S	SUPPORT	2	45	065099	M	NUT, Hex Jam, 1/4" - 20	2
14	083117	M	SPRING	1	46	072103	F	"V" BELT	1
15	029039	M	BELT GUIDE	2	47	067006	M	PIN, Cotter, 3/16" x 1-1/4"	1
16	064102	M	WASHER, Special	4	48	059004	M	CAP SCREW, 3/8" - 16 x 1"	2
17	064110	M	WASHER	2	49	059158	M	BOLT, Tap, 3/8" - 16 x 1-3/4"	2
18	029036	M	BELT GUIDE	1	50	064092	M	WASHER, Flat, 5/16"	2
19	059022	M	CAP SCREW, HH, 5/16" - 18 x 3/4"	1	51	063003	M	LOCKWASHER, 5/16"	2
20	029031	S	STRAP	1	52	065015	M	NUT, Hex, 5/16" - 18	2
21	072100	F	"V" BELT	1	53	062011	M	BOLT, Carriage, 5/16" - 18 x 3/4"	1
*22			TRANSAXLE' Tecumseh No. 1212	1	54	059023	M	CAP SCREW, HH, 3/8" - 16 x 3/4"	2
	629002	O	WHEEL ASS'Y, Rear, Consists of		55	029105	M	SHEAVE	1
23			071102 RIM	1	56	066026	M	KEY, Square, 1/4" x 1/4" x 2-1/2"	1
24			071101 TIRE, 20 x 8.00 - 10	1	57	059142	M	CAP SCREW, HH, 7-1/16" - 20 UNF x 1"	1
25	065039	M	LOCKNUT, 3/8" - 16	1	58	063005	M	LOCKWASHER, 7/16"	1
26	029160	M	SPACER	1	59	064047	M	WASHER, Special	1
27	066018	M	KEY, Square, 1/4" x 1/4" x 1-3/4"	2	60	029139	S	SPACER	1
28	064029	M	WASHER, Special	2	61	073054	M	IDLER	1
29	067027	M	COTTER, "T" Head	2	62	029263	S	BRACKET	1
30	029173	M	CAP, Grease	2	63	059069	M	CAPSCREW 5/16" - 18 x 1-1/4	1
31	023077	M	CLAMP ASS'Y	2	64	075026	M	GROMMET	2
32	064092	M	WASHER, Flat, 5/16"	2	65	064007	M	WASHER	1
					66	065042	M	LOCKNUT 5/16" - 18	1

*The Transaxle is to be serviced and warrantied by Tecumseh Products

SUGGESTED PARTS STOCKING CODE

F - FAST S - SLOW
M - MEDIUM O - CUSTOMER ORDER ONLY

CODE SUGGÈRE D'INVENTAIRE DES PIÈCES

F - FAST (rapide) S - SLOW (lent)
M - MEDIUM (moyen). O - Commande du client seulement

SHIFT CONTROL & LINKAGE - HYDROSTATIC

CHANGEMENT DE VITESSE - TRINGLERIE - MODÈLES HYDROSTATIQUES

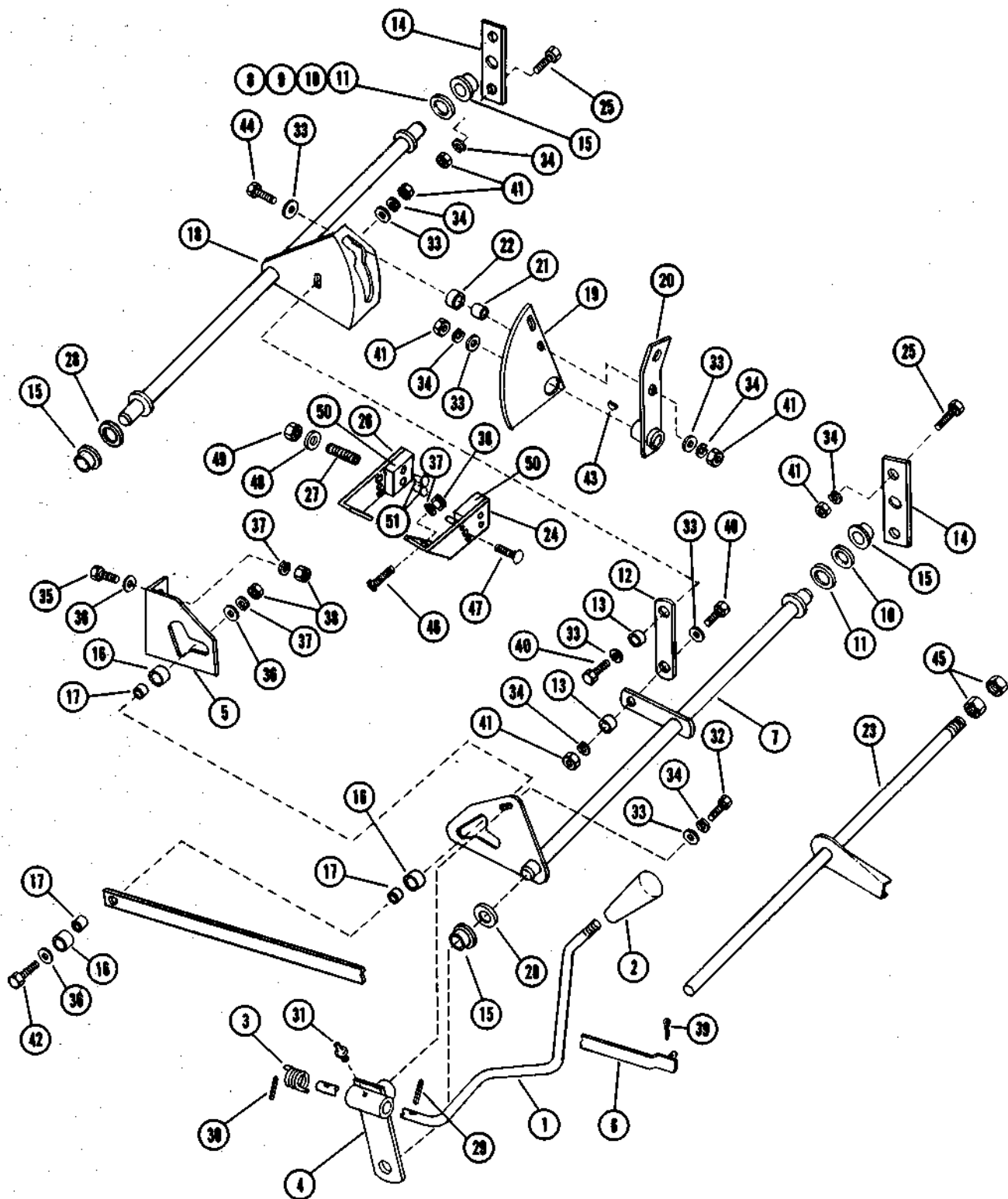

SHIFT CONTROL & LINKAGE -HYDROSTATIC

CHANGEMENT DE VITESSE - TRINGLERIE - MODÈLES HYDROSTATIQUES

NoDE REF.	NO DE PIECÉ	CODE D'INV	DESCRIPTION	QUANTITÉ NO. REQ'D	NoDE REF.	No DE PIECÉ	CODE D'INV.	DESCRIPTION	QUANTITÉ NO. REQ'D
REF. NO.	PART NO.	STOCK CODE		929002	REF. NO.	PART NO.	STOCK CODE		929002
1	029061	S	SHIFT LEVER	1	28	064009	M	WASHER, Flat, 3/4"	2
2	075049	M	HANDLE	1	29	058019	M	PIN, Grooved, 3/16" x 1 Type E	1
3	083112	M	SPRING, Tension	1	30	058049	M	PIN, Grooved, 3/16" x 1-1/4"	1
4	029055	S	PIVOT ASS'Y	1				Type E	1
5	029062	S	BRACKET	1	31	022093	F	FITTING, Grease, 1/4" - 28	1
6	029057	S	LINK	1	32	059023	M	CAP SCREW, HH, 3/8" - 16 x 3/4"	1
7	029053	S	NEUTRALIZER	1	33	064008	M	WASHER, Flat, 3/8"	7
8	064117	M	SHIM, 005 Thick	2	34	063021	M	LOCKWASHER, 3/8"	9
9	064118	M	SHIM, 010 Thick	1	35	059003	M	CAP SCREW, HH, 5/16" - 18 x 1"	2
10	064119	M	SHIM, 025 Thick	(AR 4)	36	064002	M	WASHER, Flat, 5/16"	4
11	064108	M	SHIM, Washer	(AR)	37	063003	M	LOCKWASHER, 5/16"	5
12	029064	S	ARM	1	38	065015	M	NUT, Hex, 5/16" - 18	5
13	029159	S	SPACER	2	39	067024	M	PIN, Cotter, 1/8" x 3/4"	1
14	029056	O	PLATE	2	40	059005	M	CAP SCREW, HH, 3/8" - 16 x 1-1/4"	2
15	055080	M	BUSHING	4	41	065018	M	NUT, Hex, 3/8" - 16	8
16	029066	M	ROLLER	3	42	059073	M	CAP SCREW, HH, 5/16" - 18 x	1
17	029065	M	SPACER	3				1-3/4"	1
18	029052	M	CAM	1	43	066006	M	KEY, Woodruff, No. 3	1
19	029063	S	PLATE	1	44	059027	M	CAP SCREW, HH, 3/8" - 16 x	1
20	029060	S	LEVER	1				1-3/4"	1
21	029160	M	WASHER, Spacer	1	45	065039	M	LOCKNUT, Hex, 3/8" - 16	2
22	029068	S	SPACER	1	46	062011	M	BOLT, Carriage, 5/16" - 18 x	2
23	029054	S	LEVER	1				1-3/4"	2
24	629033	M	FRONT DRAG BRKT. w/Lining	1	47	062030	M	BOLT, Carriage, 1/4" - 20 x 3-1/2"	1
25	059004	M	CAP SCREW, HH, 3/8" - 16 x 1"	4	48	064007	M	WASHER, Flat, 1/4"	1
26	629032	M	REAR DRAG BRKT. w/Lining	1	49	065070	M	LOCKNUT, Hex, 1/4" - 20	1
27	083115	M	SPRING	1	50	029220	S	LINING	2
					51	068053	S	RIVET	4

SUGGESTED PARTS STOCKING CODE

F - FAST S - SLOW
M - MEDIUM O - CUSTOMER ORDER ONLY

CODE SUGGÉRÉ D'INVENTAIRE DES PIÈCES

F - FAST (rapide) S - SLOW (lent)
M - MEDIUM (moyen) O - Commande du client seulement

HAND LIFT & SHEAVE RELEVAGE MANUEL - POULIE

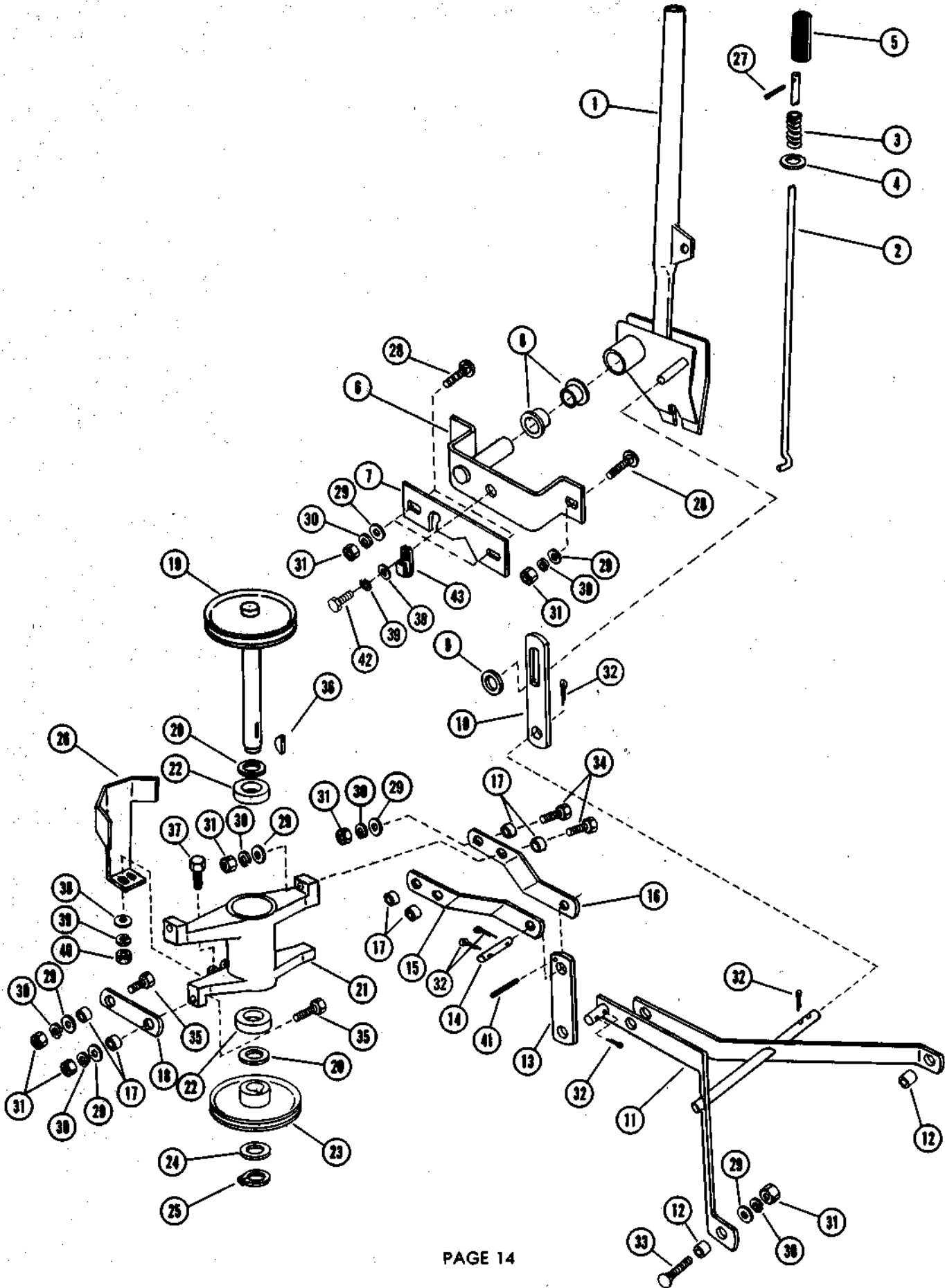

HAND LIFT & SHEAVE RELEVAGE MANUEL - POULIE

No DE REF.	NO DE CODE PIECÉ D'INV PART STOCK NO. NO. CODE	S	DESCRIPTION	QUANTITÉ NO. REQ'D 929001 929002	
1	029082	S	LIFT LEVER	1	1
2	029083	S	ROD	1	1
3	083104	S	SPRING	1	1
4	064096	M	WASHER, Special	1	1
5	075053	M	GRIP	1	1
6	029084	S	BRACKET	1	1
7	029090	S	LIFT PLATE	1	1
8	055082	F	BUSHING, Nylon	2	2
9	064097	M	WASHER, Special	1	1
10	029091	S	STRIP	1	1
11	029088	S	LIFT	1	1
12	029141	M	SPACER	2	2
13	029092	S	LINK	1	1
14	029096	M	PIN	1	1
15	029093	M	LINK, R.H.	1	1
16	029094	M	LINK, L.H.	1	1
17	55089	M	BUSHING	8	8
18	029095	M	LINK	2	2
19	029085	S	SHEAVE	1	1
20	64088	M	WASHER	2	2
21	029089	S	BEARING HOUSING	1	1
22	054073	M	BALL BEARING	2	2
23	029086	M	SHEAVE, PTO	1	1
24	064108	M	WASHER, Special	(AR)	(AR)
25	057012	M	SNAP RING	1	1
26	029087	M	BELT GUIDE	1	1
27	058034	M	ROLL PIN, 1/8" x 3/4"	1	1
28	062029	M	BOLT, Carriage 3/8" - 16 x 1"	4	4
29	064008	M	WASHER, Flat, 3/8"	14	14
30	063021	M	LOCKWASHER, 3/8"	14	14
31	065018	M	NUT, Hex, 3/8" - 16	14	14
32	067004	M	PIN, Cotter, 1/8" x 1"	6	6
33	062016	M	BOLT, Carriage, 3/8" - 16 x 1-1/4"	2	2
34	059004	M	CAP SCREW, HH, 3/8" - 16 x 1"	4	4
35	059005	M	CAP SCREW, HH, 3/8" x 16 x 1-1/4"	4	4
36	066003	M	KEY, Woodruff, No. 9	1	1
37	059003	M	CAP SCREW, HH, 5/16" - 18 x 1"	2	2
38	064002	M	WASHER, Flat, 5/16"	3	3
39	063003	M	LOCKWASHER, 5/16"	3	3
40	065015	M	NUT, Hex, 5/16" - 18	2	2
41	058050	M	PIN, Groove, 1/4" x 1-1/4" Type E	1	1
42	059039	M	CAPSCREW 5/16" - 18 x 1/2	1	1
43	069094	M	J-CLAMP	1	1

SUGGESTED PARTS STOCKING CODE

F - FAST S - SLOW
M - MEDIUM O - CUSTOMER ORDER ONLY

CODE SUGGÉRÉ D'INVENTAIRE DES PIÈCES

F - FAST (rapide) S - SLOW (lent)
M - MEDIUM (moyen) O - Commande du client seulement

PTO LINKAGE, BELT & SHEAVE TRINGLERIE DE PDF - COURROIE - POULIE

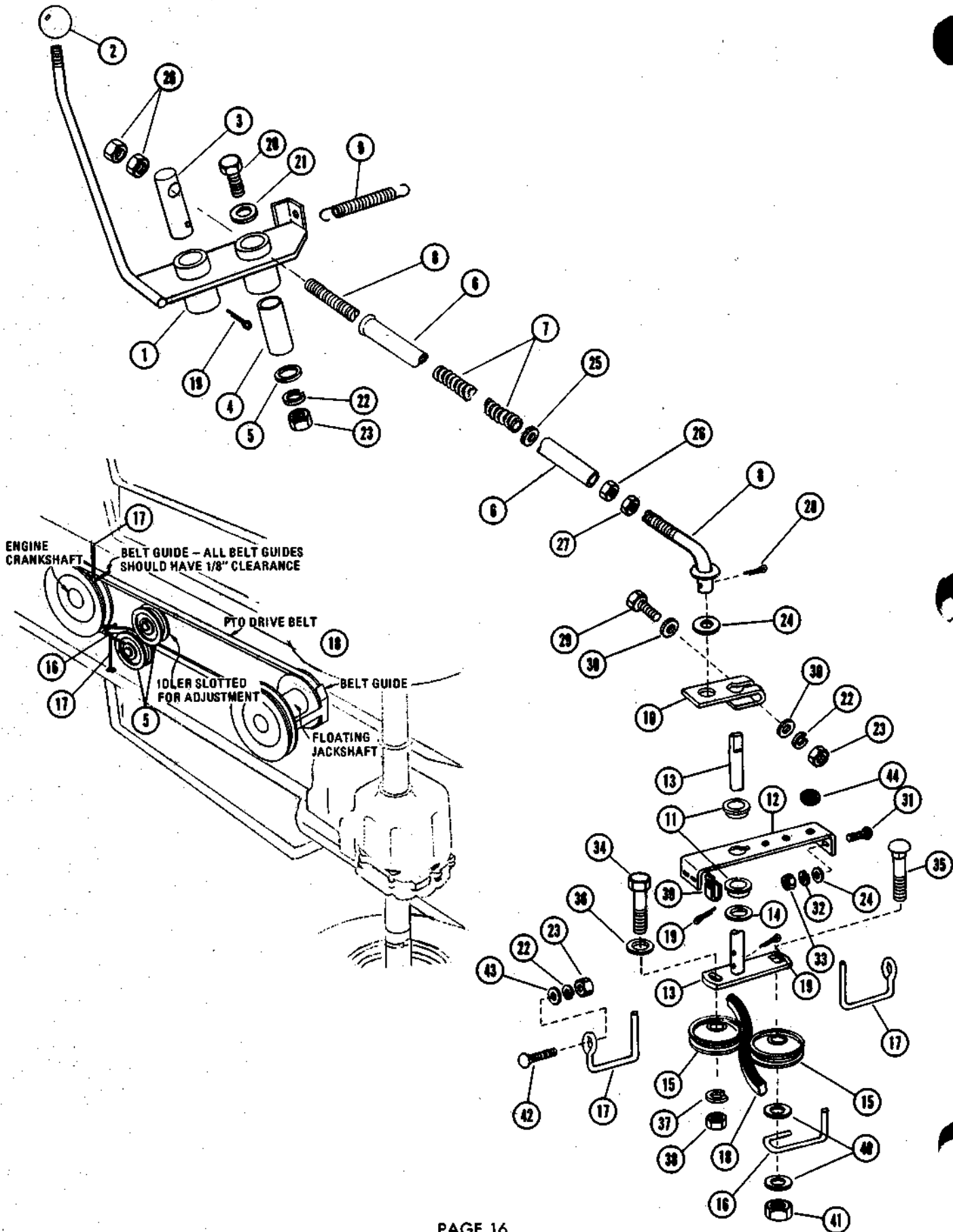

PTO LINKAGE, BELT & SHEAVE TRINGLERIE DE PDF - COURROIE - POULIE

No DE REF.	No DE PIECE	CODE D'INV.	DESCRIPTION	QUANTITÉ
REF. NO.	PART NO.	STOCK CODE		NO. REQ'D 929001 929002
1	029098	S	HANDLE	1 1
2	075052	M	KNOB	1 1
3	029104	M	PIN	1 1
4	029103	M	SPACER	1 1
5	064105	M	WASHER, Special	1 1
6	029102	S	GUIDE TUBE	1 1
7	083114	S	SPRING	1 1
8	029097	S	ROD	1 1
9	083118	M	SPRING	1 1
10	029101	M	CLEVIS	1 1
11	055084	M	BUSHING	2 2
12	029100	S	SUPPORT	1 1
13	029099	S	IDLER PIVOT	1 1
14	064100	M	WASHER, Special	1 1
15	073101	M	IDLER	2 2
16	029136	M	BELT FINGER	1 1
17	029137	M	BELT FINGER	2 2
18	072101	F	"V" BELT	1 1
19	067004	M	PIN, Cotter, 1/8" x 1"	3 3
20	059149	M	CAP SCREW, HH, 3/8" - 16 x 2-1/4" Grade 5	1 1
21	064008	M	WASHER, Flat, 3/8"	1 1
22	063021	M	LOCKWASHER, 3/8"	4 4
23	065018	M	NUT, Hex, 3/8" - 16	4 4
24	064007	M	WASHER, Flat, 1/4"	5 5
25	064002	M	WASHER, Flat, 5/16"	1 1
26	065015	M	NUT, Hex, 5/16" - 18	3 3
27	065061	M	NUT, Hex Jam, 5/16" - 18	1 1
28	067016	M	PIN, Cotter, 5/32" x 1"	1 1
29	059068	M	CAP SCREW, HH, 3/8" - 16 x 2"	1 1
30	064043	M	WASHER, Flat, 3/8"	2 2
31	062012	M	BOLT, Carriage, 1/4" - 20 x 3/4"	4 4
32	063002	M	LOCKWASHER, 1/4"	4 4
33	065032	M	NUT, Hex, 1/4" - 20	4 4
34	059041	M	CAP SCREW, HH, 1/2" - 13 x 2-1/4"	1 1
35	062006	M	BOLT, Carriage, 1/2" - 13 x 2-1/2"	1 1
36	064120	M	WASHER, Flat, 1/2"	1 1
37	063006	M	LOCKWASHER, 1/2"	1 1
38	065021	M	NUT, Hex, 1/2"	1 1
39	064094	M	J-CLAMP	1 1
40	064047	M	WASHER, Flat, 1/2"	2 2
41	065097	M	LOCKNUT, Hex, 1/2" - 13	1 1
42	062029	M	BOLT, Carriage, 3/8" - 16 x 1"	2 2
43	064102	M	WASHER, Special	2 2
44	075055	M	GROMMET	1 1

SUGGESTED PARTS STOCKING CODE

F - FAST S - SLOW
 M - MEDIUM O - CUSTOMER ORDER ONLY

CODE SUGGÉRÉ D'INVENTAIRE DES PIÈCES

F - FAST (rapide) S - SLOW (lent)
 M - MEDIUM (moyen) O - Commande du client seulement

DASH, DASH CONTROLS & ELECTRICAL TABLEAU DE BORD - COMMANDES - SYSTÈME ÉLECTRIQUE

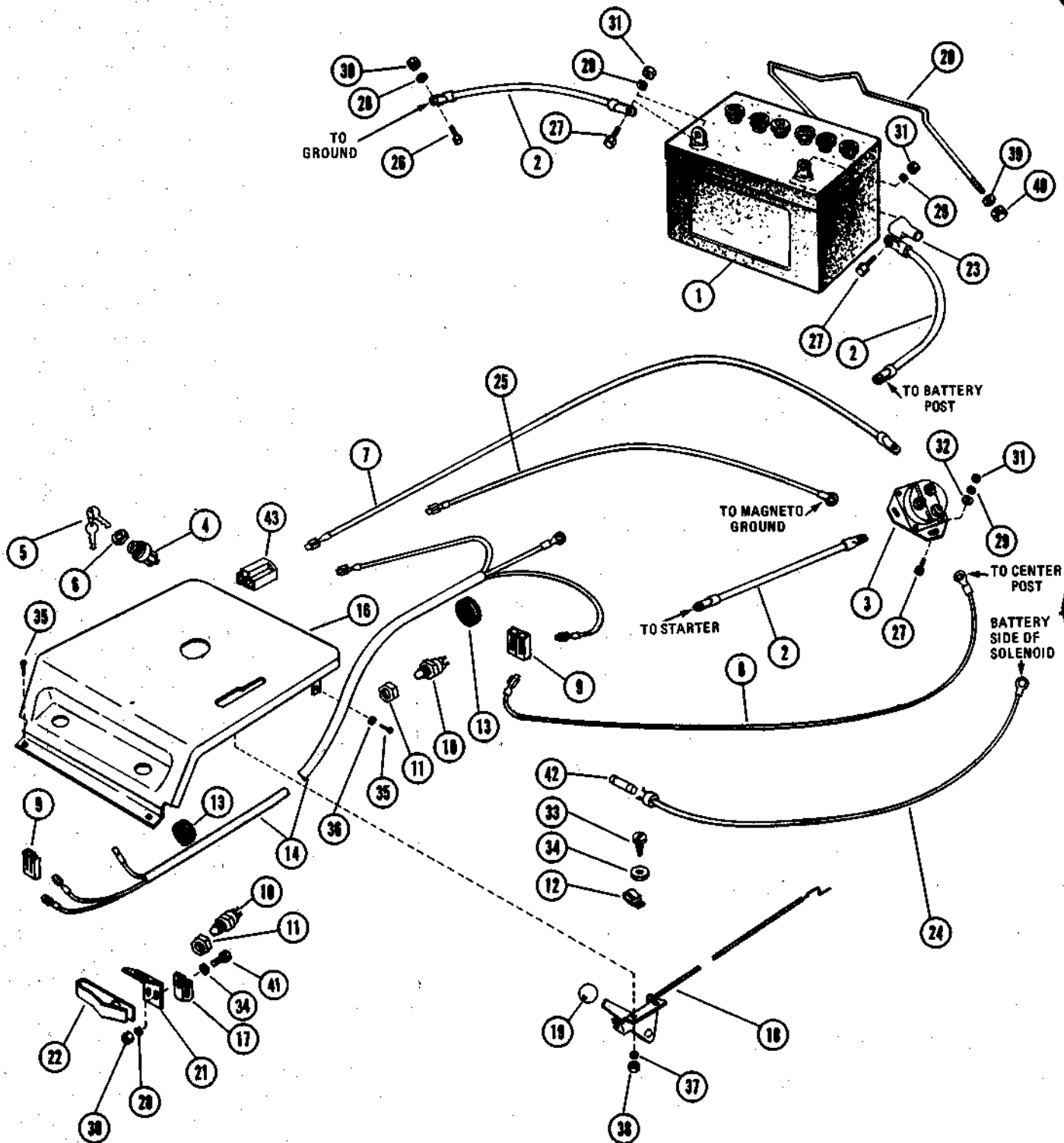

DASH, DASH CONTROLS & ELECTRICAL TABLEAU DE BORD - COMMANDES - SYSTÈME ÉLECTRIQUE

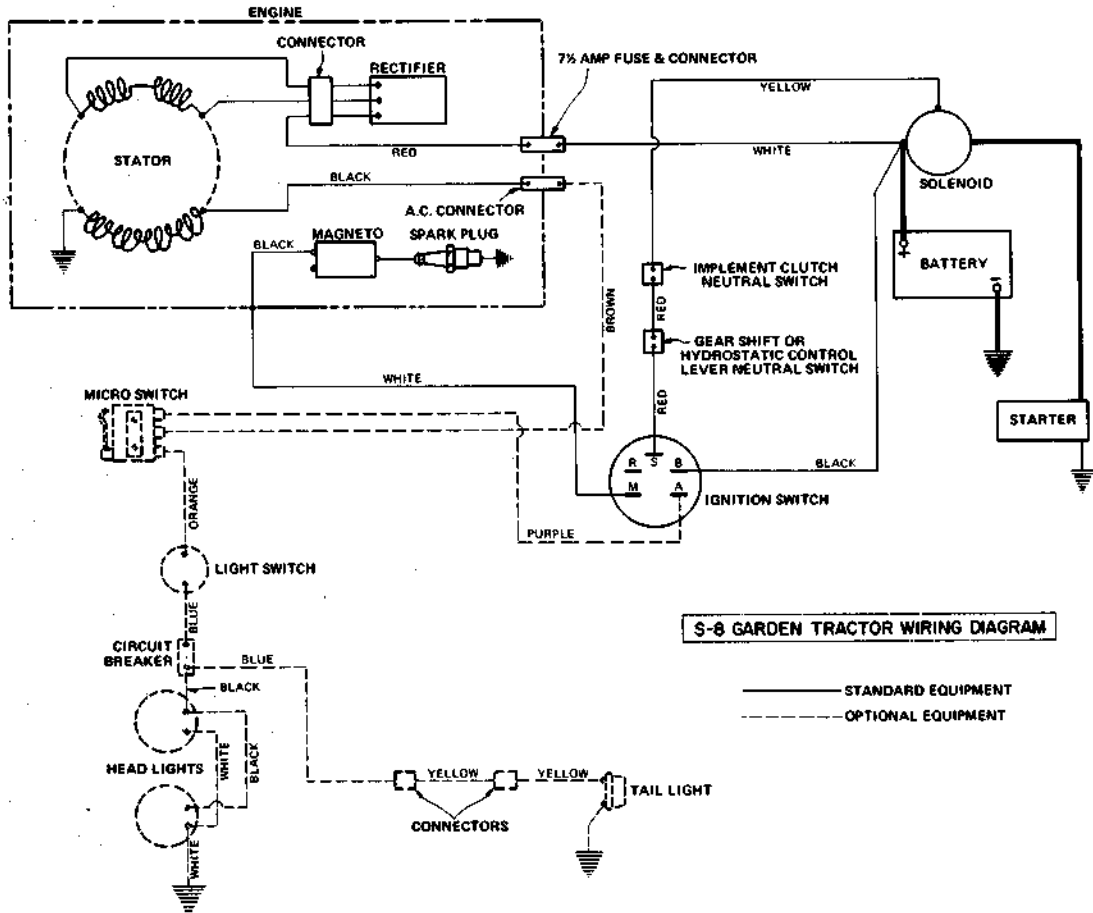

No DE REF.	No DE PIECÉ D'INV.	CODE	DESCRIPTION	QUANTITÉ	No. REQ'D	No DE REF.	No DE PIECÉ D'INV.	CODE	DESCRIPTION	QUANTITÉ	No. REQ'D
NO.	PART NO.	STOCK CODE		929001	929002	NO.	PART NO.	STOCK CODE		929001	929002
1	029175	M	BATTERY, 12 Volt	1	1	23	075057	M	INSULATOR	1	1
2	029026	S	CABLE	3	3	24	029164	M	WIRE	1	1
3	029132	M	SOLENOID	1	1	25	029168	M	WIRE 14" long, White	1	1
4	029149	M	SWITCH, Ignition	1	1	26	959022	M	CAP SCREW, 5/16" - 18 x 3/4"	1	1
5	013157	F	KEY SET	1	1	27	059001	M	CAP SCREW, HH, 1/4" - 20 x 3/4"	4	4
6	065106	M	NUT, Special, 9/16" - 24	1	1	28	063003	M	LOCKWASHER, 5/16"	3	1
7	029167	M	WIRE ASS'Y, 29" long Black	1	1	29	063002	M	LOCKWASHER, 1/4"	4	4
8	029169	M	WIRE ASS'Y, 24" long, Yellow	1	1	30	065015	M	NUT, Hex, 5/16" - 18	3	1
9	029170	M	CONNECTOR HOUSING, 2 Wire	2	2	31	065032	M	NUT, Hex, 1/4" - 20	4	4
10	029131	M	SWITCH, Safety	2	2	32	064007	M	WASHER, Flat, 1/4"	2	2
11	065096	M	NUT, Special, 9/16" - 18 UNF	2	2	33	074040	M	SCREW, Self Tapping 5/16" x 1/2"	1	1
12	069094	M	CLIP	1	1	34	064002	M	WASHER, Flat, 5/16"	3	1
13	075055	M	GROMMET	2	2	35	074043	M	SCREW, Self Tapping, RH, 10 - 29 x 1/2"	5	5
14	029166	S	WIRE HARNESS (Mechanical)	1		36	064001	M	WASHER, 3/16" Wrought	2	2
15	029165	S	WIRE HARNESS (Hydrostatic)	1		37	063011	M	LOCKWASHER, No. 10	2	2
16	529003	O	DASH W/Decal	1	1	38	065055	M	NUT, Hex, No. 10 - 24	2	2
17	069094	M	J CLAMP	1		39	064123	M	WASHER, Flat, 5/16"	2	2
18	069095	F	THROTTLE CONTROL	1	1	40	065095	M	LOCKNUT, Hex, 5/16" - 18	2	2
19	075019	M	KNOB	1	1	41	059003	M	CAP SCREW, HH, 5/16" - 18 x 1"	2	
20	029128	S	ROD, Battery Hold Down	1	1	42	013198	F	FUSE	1	1
21	029129	S	BRACKET, Safety Sw.	1		43	023478	M	CONNECTOR HOUSING	1	1
22	029130	M	ACTUATOR, Safety Sw.	1							

SUGGESTED PARTS STOCKING CODE PAGE 19
 F - FAST S - SLOW
 M - MEDIUM O - CUSTOMER ORDER ONLY

CODE SUGGÉRÉ D'INVENTAIRE DES PIÈCES
 F - FAST (rapide) S - SLOW (lent)
 M - MEDIUM (moyen) O - Commande du client seulement

BRAKE & PARKING BRAKE FREIN ET FREIN DE STATIONNEMENT

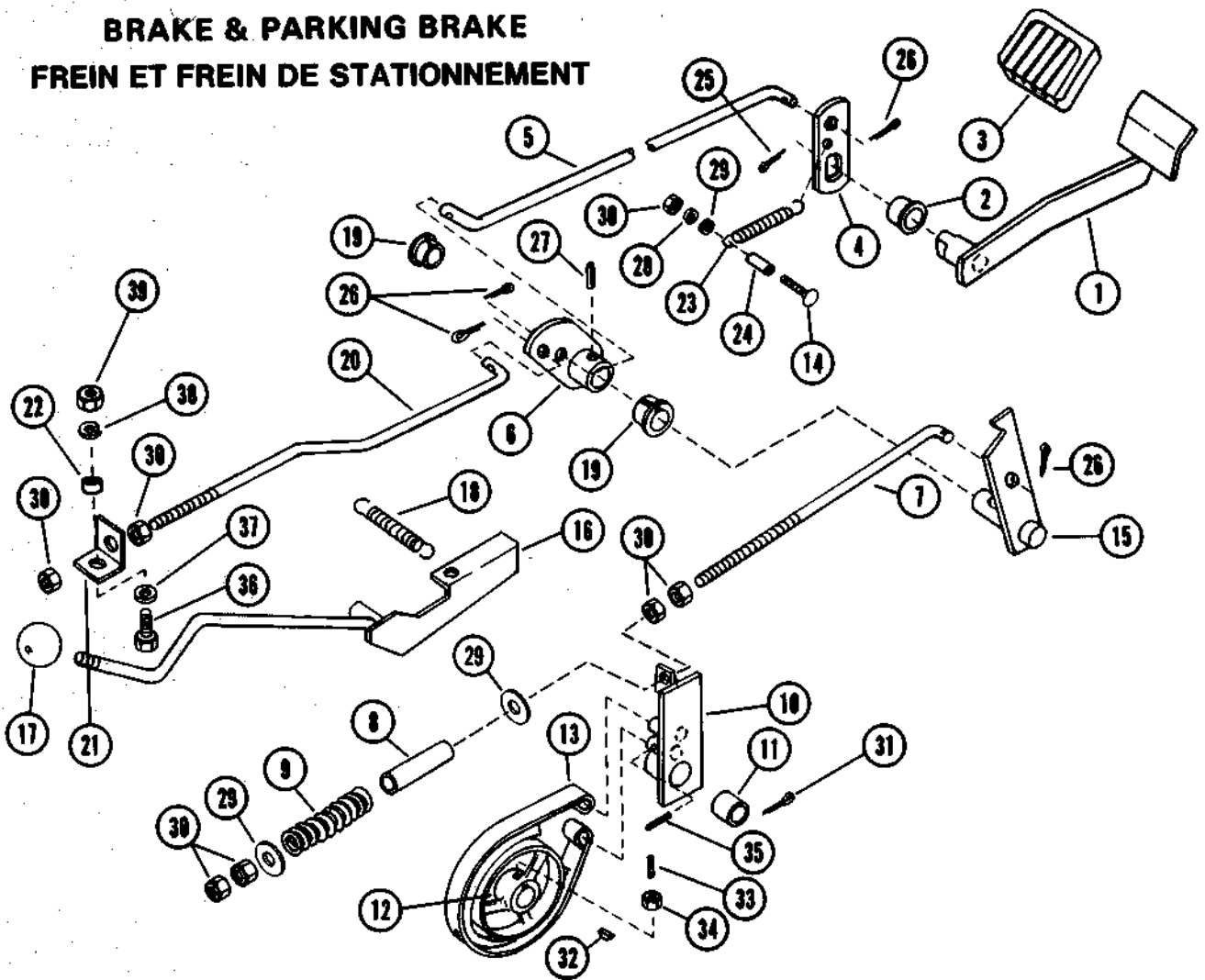

NoDE REF.	NO DE CODE PIECÉ D'INV PART STOCK NO. NO. CODE	DESCRIPTION	QUANTITÉ NO. REQ'D		NoDE REF.	NO DE CODE PIECÉ D'INV. PART STOCK NO. NO. CODE	DESCRIPTION	QUANTITÉ NO. REQ'D	
			929001	929002				929001	929002
1	029067	O BRAKE PEDAL	1	1	22	055089	M BUSHING	1	
2	055081	M BEARING, Nylon	1	1	23	083117	M SPRING	1	1
3	075051	S PAD, Pedal	1	1	24	029144	S SPACER BUSHING	1	1
4	029081	S ARM	1	1	25	067021	M PIN, cotter, 1/8" x 1-1/2"	1	1
5	029076	S ROD	1	1	26	067024	M PIN, Cotter, 1/8" x 3/4"	4	3
6	029069	S ARM	1	1	27	058049	M PIN, Grooved, 3/16" x 1-1/4" Type E	1	1
7	029078	S BRAKE ROD	1	1	28	063003	M LOCKWASHER, 5/16"	1	1
8	029079	S SPACER	1	1	29	064002	M WASHER, Flat, 5/16"	2	2
9	083113	M SPRING, Compression	1	1	30	065015	M NUT, Hex, 5/16" - 18	7	5
10	029070	O BRAKE PIVOT (Gear)	1		31	067002	M PIN, Cotter, 3/32" x 1"	1	1
	029071	O BRAKE PIVOT (Hydrostatic)	1		32	066003	M KEY, Woodruff, No. 9	1	1
11	055024	M BUSHING	1	1	33	060030	M SCREW, Hex Socket, 1/4" - 20 x 5/8"	1	1
12	029037	S BRAKE DRUM	1	1	34	065099	M NUT, Hex Jam, 1/4" - 20	1	1
13	29252	M BRAKE BAND, W/Lining	1	1	35	058019	M PIN, Grooved, 3/16" x 1" Type E	2	2
14	062023	M BOLT, Carriage 5/16" - 18 x 1-1/2"	1	1	36	059005	M CAP SCREW, 3/8" - 16 x 1-1/4"	1	1
15	029072	O ARM	1	1	37	064008	M WASHER, Flat, 3/8"	1	
16	029073	S BRAKE LOCK	1	1	38	063021	M LOCKWASHER, 3/8"	1	
17	075052	M KNOB	1	1	39	065018	M NUT, Hex, 3/8" - 16	1	
18	083109	M SPRING	1	1					
19	055077	M BEARING, Nylon	2	2					
20	029077	S ROD	1						
21	029080	S ANGLE	1						

SUGGESTED PARTS STOCKING CODE

F - FAST S - SLOW PAGE 20
M - MEDIUM O - CUSTOMER ORDER ONLY

CODE SUGGÉRÉ D'INVENTAIRE DES PIÈCES

F - FAST (rapide) S - SLOW (lent)
M - MEDIUM (moyen) O - Commande du client seulement

SHIFT CONTROL & LINKAGE - GEAR

CHANGEMENT DE VITESSE - TRINGLERIE - MODÈLES MÉCANIQUES

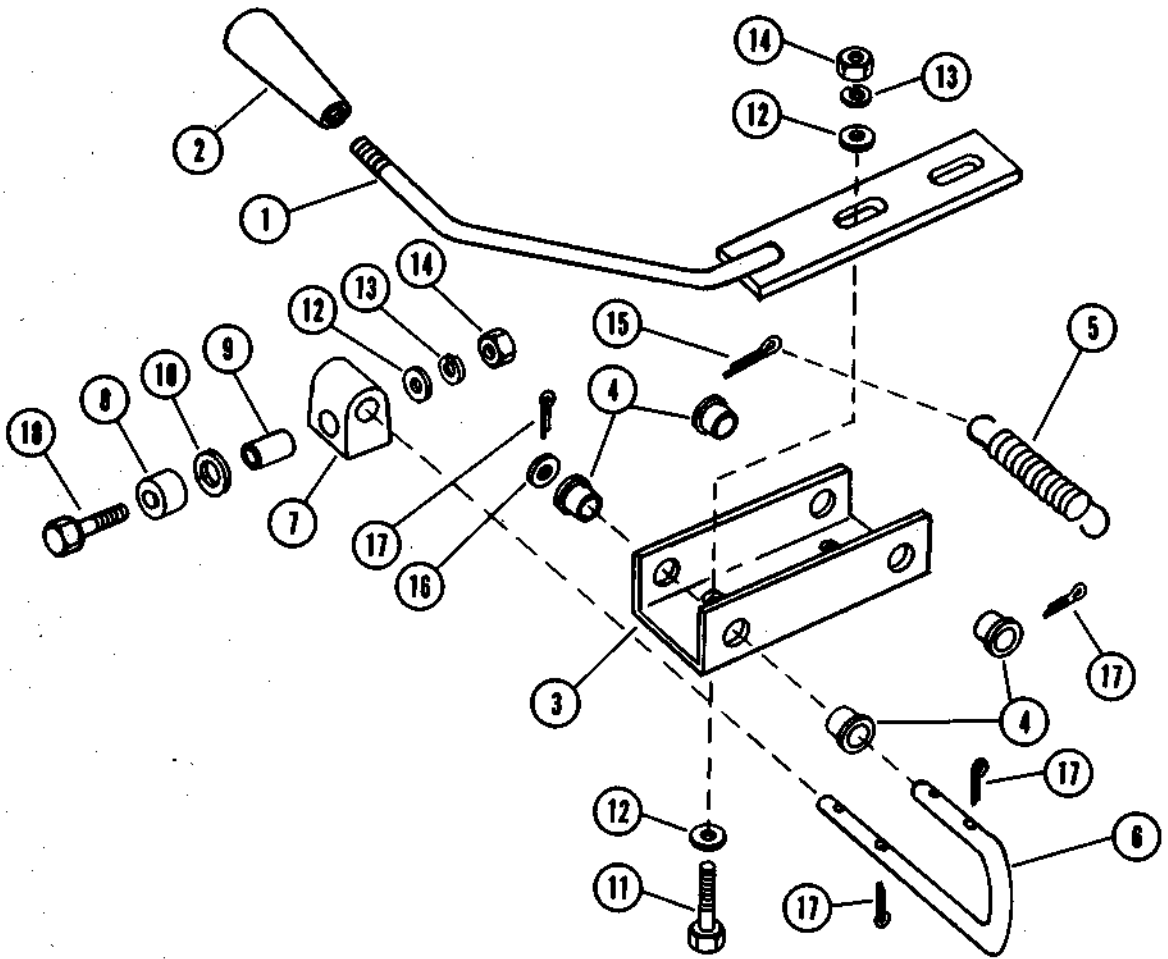

NO REF.	NO DE PIECÉ D'INV PART STOCK NO. NO. CODE	CODE O	DESCRIPTION	QUANTITÉ NO. REQ'D
1	029047	O	LEVER ASSEMBLY	1
2	075049	M	HANDLE	1
3	029048	O	CHANNEL	1
4	055078	M	BUSHING, Nylon	4
5	083116	M	SPRING	1
6	029049	S	ROD	1
7	029050	M	PIVOT	1
8	029051	M	SPACER	1
9	029025	M	SPACER, Bushing	1
10	064104	M	WASHER, Special	1
11	059003	M	CAP SCREW, HH, 5/16" - 18 x 1"	2
12	064002	M	WASHER, Flat, 5/16"	5
13	063003	M	LOCKWASHER, 5/16"	3
14	065015	M	NUT, Hex, 5/16" - 18	3
15	067021	M	PIN, Cotter, 1/8" x 1-1/2"	1
16	064121	M	WASHER, Flat, 7/16"	6
17	067004	M	PIN, Cotter, 1/8" x 1"	5
18	059074	M	CAP SCREW, HH, 5/16" - 18 x 2-3/4"	1

SUGGESTED PARTS STOCKING CODE

F - FAST S - SLOW
 M - MEDIUM O - CUSTOMER ORDER ONLY

CODE SUGGÉRÉ D'INVENTAIRE DES PIÈCES

F - FAST (rapide) S - SLOW (lent)
 M - MEDIUM (moyen) O - Commande du client seulement

ROTARY MOWER - 36RM - 829001

TONDEUSE ROTATIVE 36RM - MODÈLE 829001

SERIAL NUMBER 000301 AND UP

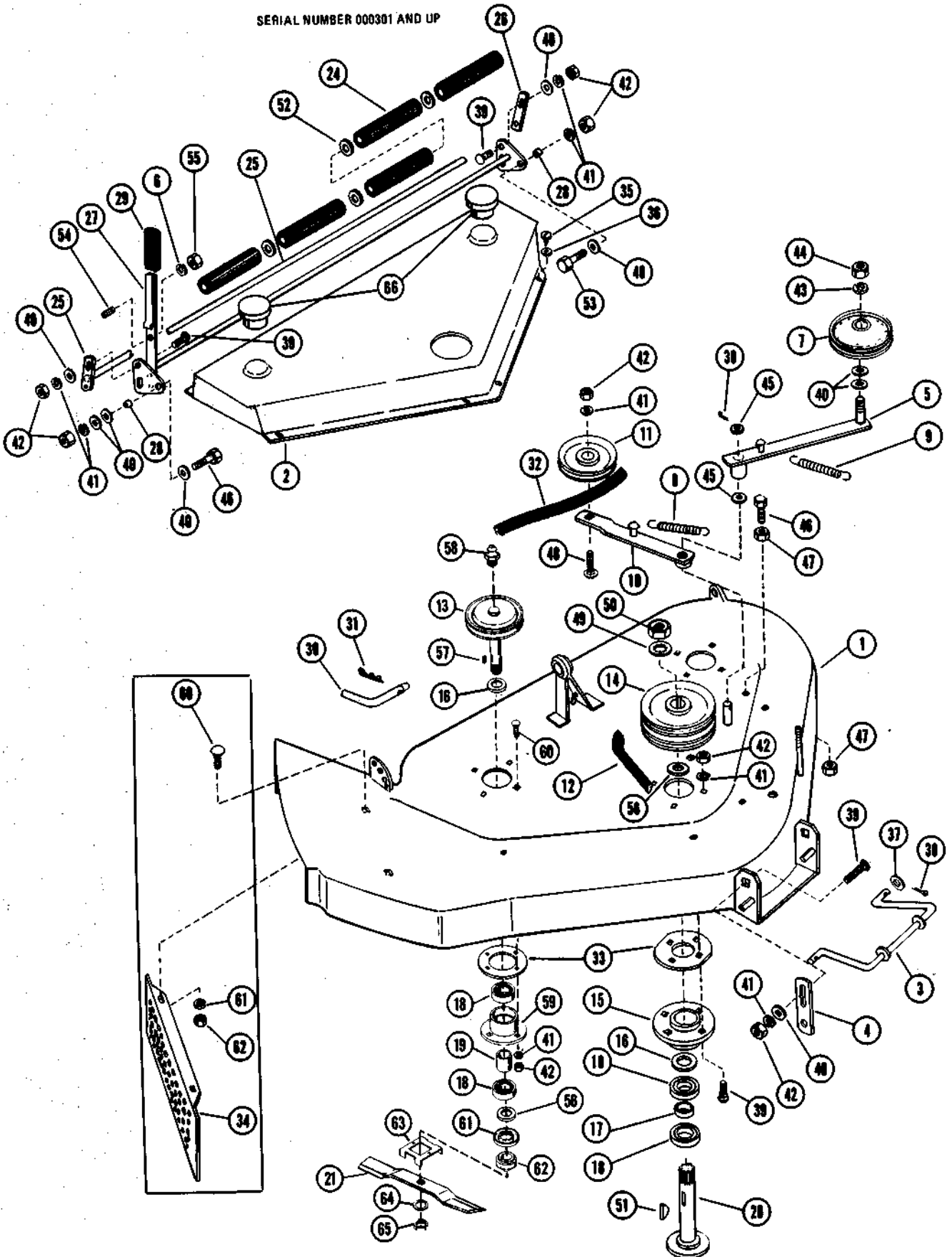

ROTARY MOWER - 36RM - 829001

TONDEUSE ROTATIVE 36RM - MODÈLE 829001

SERIAL NUMBER 000301 AND UP

NoDE REF.	NO DE PIECÉ D'INV. PART STOCK NO.	CODE D'INV. CODE	DESCRIPTION	QUANTITÉ NO. REQ'D	NoDE REF.	NO DE PIECÉ D'INV. PART STOCK NO.	CODE D'INV. CODE	DESCRIPTION	QUANTITÉ NO. REQ'D
1	529004	O	MOWER DECK, 36"	1	36	064007	M	WASHER, Flat, 1/4"	6
2	029146	O	SHIELD	1	37	064039	M	WASHER, Special	2
3	029153	O	SUPPORT	1	38	067004	M	PIN, Cotter, 1/8" x 1"	3
4	029176	S	LINK	2	39	062029	M	BOLT, Carriage, 3/8" - 16 x 1"	16
5	029152	S	IDLER ARM	1	40	064008	M	WASHER, Flat, 3/8"	10
6	063011	M	LOCKWASHER, No. 10	1	41	063021	M	LOCKWASHER, 3/8"	19
7	073059	M	IDLER	1	42	065018	M	NUT, Hex, 3/8" - 16	19
8	083117	M	SPRING	1	43	063006	M	LOCKWASHER, 1/2"	1
9	083127	M	SPRING	1	44	065021	M	NUT, Hex, 1/2" - 13	1
10	029151	S	IDLER ARM	1	45	064003	M	WASHER, Flat, 1/2"	2
11	073054	M	IDLER	1	46	059005	M	CAP SCREW, H.H. 3/8" - 16 x 1-1/4"	2
12	072077	F	"V" BELT	1	47	065001	M	NUT, Hex, Jam, 3/8" - 16	2
13	031943	M	SPINDLE SHEAVE	2	48	062016	M	BOLT, Carriage, 3/8" - 16 x 1-1/4"	1
14	029154	M	SHEAVE	1	49	063027	M	LOCKWASHER, Int, Tooth 3/4"	1
15	031044	S	FLANGE	1	50	065016	M	NUT, Hex, Jam, 3/4" - 16 UNF	1
16	064048	M	WASHER, Special	3 (AR)	51	066003	M	KEY, Woodruff, No. 9	1
17	031144	S	SPACER, Split (.445 Thick)	1	52	064140	M	WASHER, Flat, 5/8"	4
18	054120	F	BEARING, Ball	6	53	059004	M	CAP SCREW, HH. 3/8" - 16 x 1"	1
19	031942	S	SPACER	2	54	059156	M	CAP SCREW, Socket Hd. No. 10-24 x 3/8"	1
20	029155	M	SHAFT, Center	1	55	065055	M	NUT, Hex, No. 10 - 24	1
21	029157	F	BLADE	3	56	064108	M	WASHER	6
22	031191	M	WASHER, Special	1	57	066014	M	KEY, 3/16 x 5/8	2
23	059153	M	CAP SCREW, Hex 7/16" - 20 x 1" UNF Gr. 5	1	58	022093	F	ZERK FITTING	2
24	031141	F	ROLLER	5	59	031933	O	SPINDLE HOUSING	2
25	029150	S	SHAFT	1	60	062029	M	CARRIAGE BOLT, 3/8" x 1	8
26	031156	S	LINK	1	61	003419	M	BEARING SLINGER	2
27	629019	M	ADJUSTER, Roller	1	62	003169	M	RETAINER HUB	2
28	055089	M	BUSHING	2	63	031944	M	BLADE TRAY	2
29	075069	M	GRIP	1	64	063008	M	LOCKWASHER	2
30	029178	M	PIN	1	65	065025	M	NUT, Jam	2
31	067029	M	HAIRPIN COTTER	1	66	075040	M	PLUG	2
32	072078	F	"V" BELT	1	*Mulcher Kit Consists of Mulcher Plate and the Following Hardware:				
33	029177	M	SHIM	9 (AR)	60	062035		BOLT CARRIAGE, 3/8" x 3/4"	2
*34	729004	O	MULCHER KIT		61	063021		LOCKWASHER, 3/8"	2
35	074046	M	SCREW, Self Tapping H.H. 1/4" x 1/2"	6	62	065018		NUT, Hex, 3/8" - 16	2

SUGGESTED PARTS STOCKING CODE

F - FAST S - SLOW
M - MEDIUM O - CUSTOMER ORDER ONLY

CODE SUGGÉRÉ D'INVENTAIRE DES PIÈCES

F - FAST (rapide) S - SLOW (lent)
M - MEDIUM (moyen) O - Commande du client seulement

FRONT BLADE - 42FB - 829002

LAME 42FB - 829002

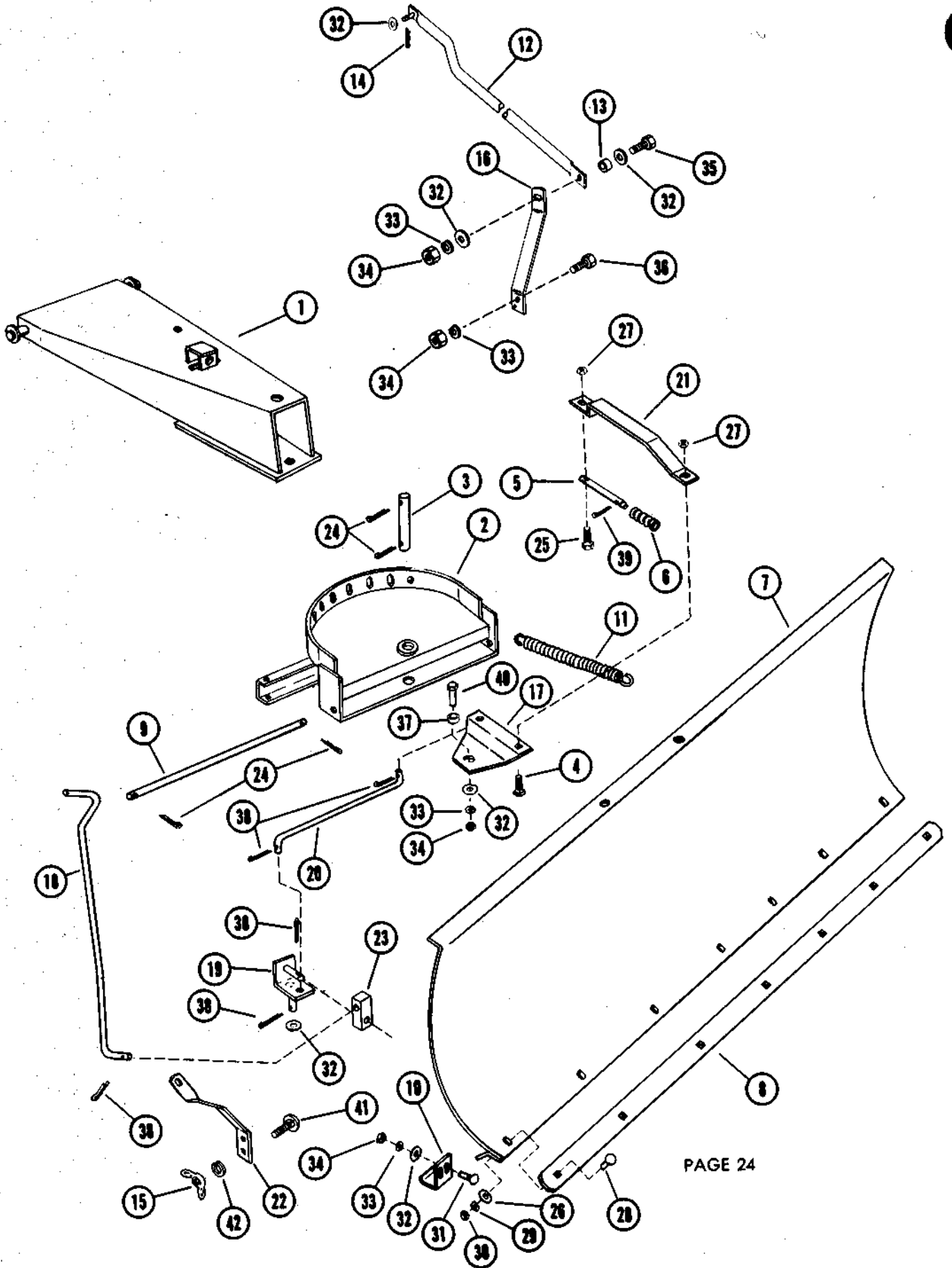

HEADLIGHT KIT - MODEL 729005 COLIS DE PHARES - MODÈLE 729005

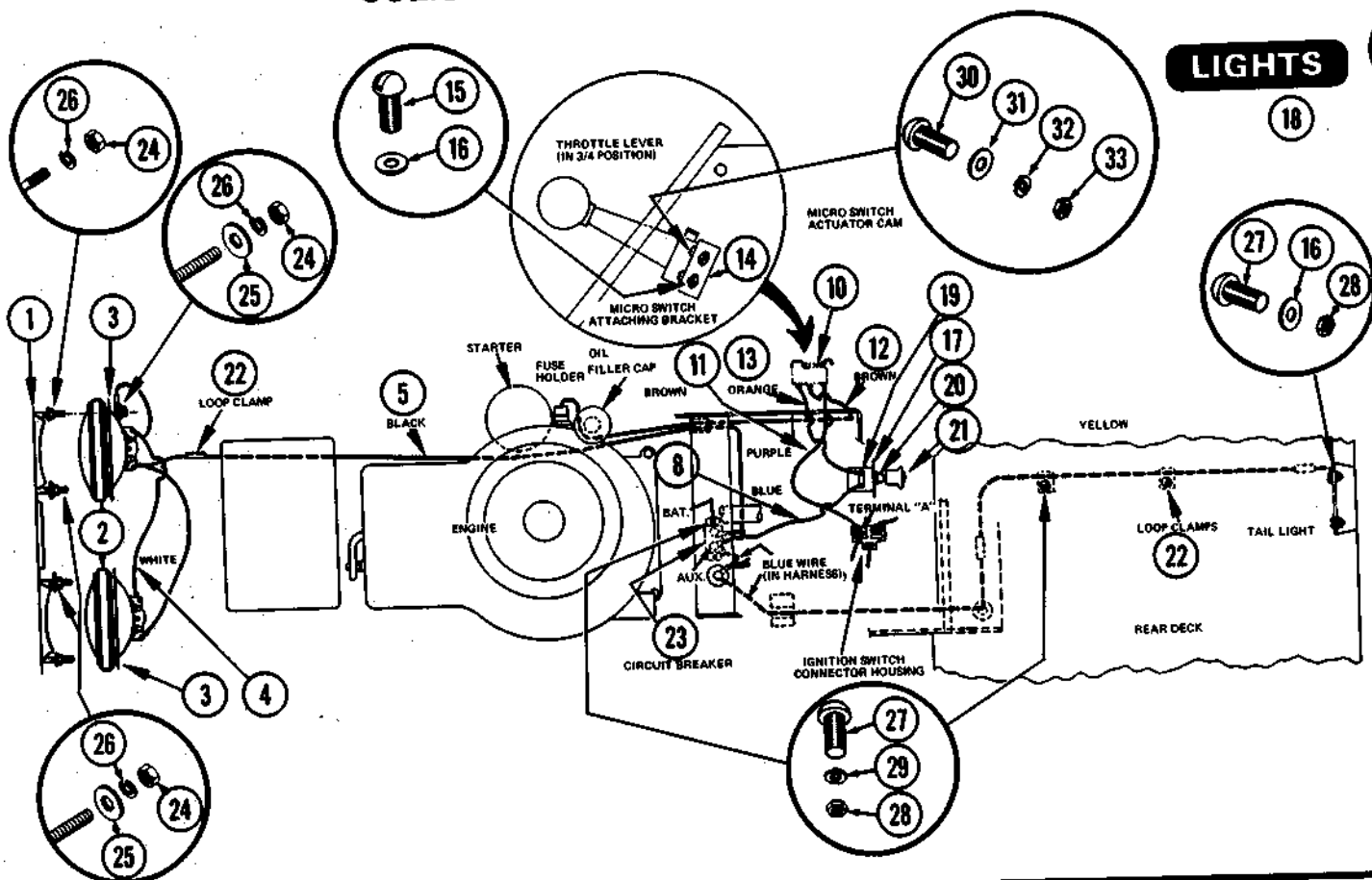

NoDE REF.	No DE CODE PIECE D'INV. PART STOCK NO.	DESCRIPTION	QUANTITÉ NO. REQ'D	NoDE REF.	No DE CODE PIECE D'INV. PART STOCK NO.	DESCRIPTION	QUANTITÉ NO. REQ'D
1	029206 S	HEADLIGHT INSERT	1	21	075068 M	KNOB	1
2	031159 M	HEADLIGHT RETAINER RING	2	22	029205 M	CLAMP LOOP	4
3	031149 F	HEADLIGHT	2	23	031108 M	CIRCUIT BREAKER	1
4	029207 M	WIRE - White - Headlight Ground	1	24	065032 M	NUT, Hex, 1/4-20	8
5	029208 M	WIRE - Black - Circuit Breaker to Headlight	1	25	064007 M	WASHER, Flat, 1/4 STD	6
6	631006 M	TAILLIGHT ASSEMBLY	1	26	063002 M	LOCKWASHER, 1/4 STD	8
7	029202 M	WIRE - Yellow - Taillight	1	27	061017 M	SCREW, Machine, No. 10-24 x 5/8	6
8	029204 M	WIRE - Blue - Switch to Circuit Breaker	1	28	065055 M	NUT, Hex, No. 10-24	6
9	031101 M	WIRE CONNECTOR	1	29	063011 M	LOCKWASHER, No. 10	6
10	029212 M	MICRO SWITCH	1	30	061051 M	SCREW, Machine No. 2-56	2
11	029209 M	WIRE - Purple - Micro Switch to Ignition Switch	1	31	064143 M	WASHER, Flat, No. 2	2
12	029210 M	WIRE - Brown - Micro Switch to Engine	1	32	063031 M	LOCKWASHER, No. 2	2
13	029211 M	WIRE - Orange - Micro Switch to Light Switch	1	33	065111 M	NUT, Hex, No. 2 - 56	2
14	029203 M	BRACKET, Micro Switch	1				
15	074048 M	SCREW, Tapping, No. 10 x 3/8	2				
16	064001 M	WASHER, Flat, 3/16 STD	5				
17	031151 M	LIGHT SWITCH	1				
18	078297 S	DECAL, "Lights"	1				
19	031105 M	CONNECTOR, Light Switch	1				
20	065104 M	NUT, 1/2 - 20	1				

SUGGESTED PARTS STOCKING CODE PAGE 26

F - FAST S - SLOW
M - MEDIUM O - CUSTOMER ORDER ONLY

CODE SUGGÈRE D'INVENTAIRE DES PIÈCES

F - FAST (rapide) S - SLOW (lent)
M - MEDIUM (moyen) O - Commande du client seulement

FRAME, STEERING, FRONT AXLE, FRONT WHEEL & SPINDLE

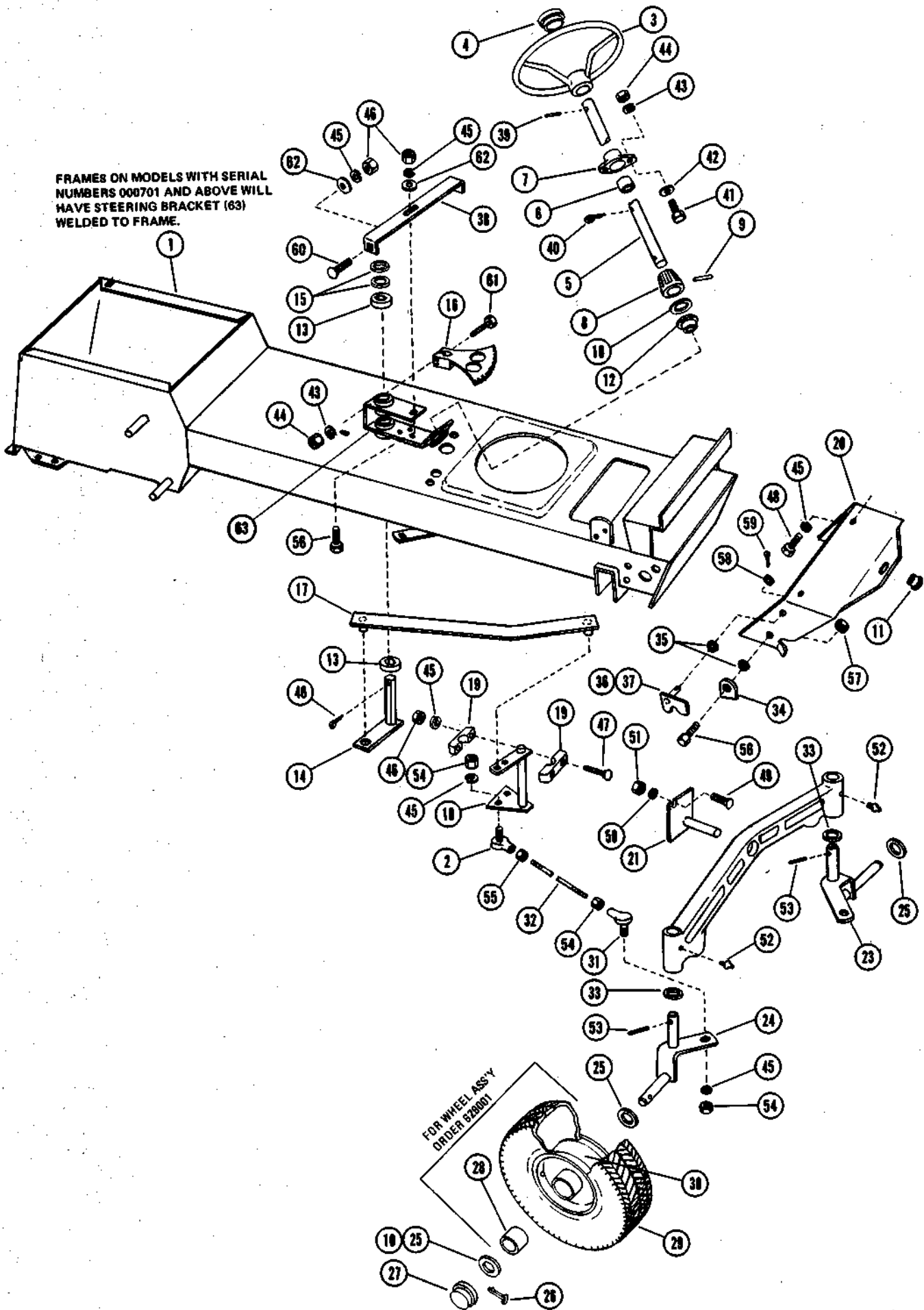

FRAME, STEERING, FRONT AXLE, FRONT WHEEL & SPINDLE

REF NO.	PART NO.	DESCRIPTION	929001	929002	REF NO.	PART NO.	DESCRIPTION	929001	929002
1	029002	FRAME, Gear	1		33	075059	WASHER, Thrust	2	2
	529009	FRAME, Hydrostatic		1	34	029013	LOCK STRIP	2	2
2	029158	L.H. BALL JOINT	2	2	35	029024	WASHER, Spring	4	4
3	629007	STEERING WHEEL W/Cap	1	1	36	029015	LATCH, L.H.	1	1
4	029163	CAP	1	1	37	029014	LATCH, R.H.	1	1
5	029020	STEERING COLUMN	1	1	38	029018	BRACKET	1	1
6	029023	SPACER	1	1	39	058004	PIN, Spring, 1/4" x 1-1/2"	1	1
7	054025	BEARING, Side Flange	1	1	40	067006	PIN, Cotter, 3/16" x 1-1/4"	2	2
8	029021	PINION GEAR	1	1	41	059003	CAP SCREW, HH, 5/16" - 18 x 1	2	2
9	029133	NEEDLE ROLLER	1	1	42	064002	WASHER, Flat, 5/16"	4	4
*10	064095	WASHER, Special	3	3	43	063003	LOCKWASHER, 5/16"	4	4
*11	055076	BUSHING' Nylon	1	1	44	065015	NUT, Hex, 5/16" - 18	4	4
**12	055080	BUSHING	1	1	45	063021	LOCKWASHER, 3/8"	13	13
13	055083	BUSHING, Hex Bore	2	2	46	065018	NUT, Hex, 3/8" - 16	7	7
14	029017	ARM & SHAFT	1	1	47	062005	BOLT, Carriage, 3/8" - 16 x 2-1/2"	4	4
15	064111	WASHER, 7/8" I.D. x 1-1/4" O.D.	2	2	48	059133	CAP SCREW, HH, 3/8" - 16 x 1-1/4"	2	2
16	029019	BEVEL GEAR SEGMENT	1	1			Grade 5		
17	029012	LINK	1	1	49	062012	BOLT, Carriage, 1/4" - 20 x 3/4"	1	1
18	029010	CRANK	1	1	50	063002	LOCKWASHER, 1/4"	1	1
19	029011	BLOCK	4	4	51	065032	NUT, Hex, 1/4" - 20	1	1
20	029007	MOUNTING, Front	1	1	52	022093	FITTING, Grease	2	2
21	029006	AXLE PIVOT	1	1	53	058050	PIN, Grooved, 1/4" x 1-1/4" Type E	2	2
22	029005	AXLE, Front	1	1	54	065005	NUT, Hex, 3/8" x 24 UNF.	6	6
23	029008	SPINDLE, L.H.	1	1	55	065073	NUT, Hex, 3/8" - 24 UNF L.H.	2	2
24	029009	SPINDLE, R.H.	1	1	56	059004	CAP SCREW, HH, 3/8" - 16 x 1"	3	3
25	064109	WASHER, Special	4	4	57	065098	LOCKNUT, Hex, 3/8" - 16	2	2
26	067027	COTTER, "T" Head	2	2	58	064069	WASHER, Flat, 3/8"	4	4
27	029173	GREASE CAP	2	2	59	067024	PIN, Cotter, 1/8" x 3/4"	2	2
	629001	WHEEL ASS'Y (Consists of)	2	2	60	062029	BOLT, Carriage, 3/8" - 16 x 1"	2	2
28		055086 BUSHING	2	2	61	059128	CAP SCREW, HH, 5/16" - 18 x 1-3/4" Grade 5	2	2
29		071099 TIRE, 15 x 6.00	1	1					
30		071100 WHEEL	1	1	62	064008	WASHER, Flat, 3/8"	3	3
31	029171	BALL JOINT, R.H.	2	2		78280	WARNING DECAL (Not. III.)		1
32	029016	TIE ROD	2	2	*63	29248	STEERING BRACKET	1	1

*Used on Models With Serial Numbers Below 000700.

**Used on Models With Serial Numbers 000701 and Above.

HOOD, REAR DECK, SEAT, DASH SUPPORT, RUNNING BOARD

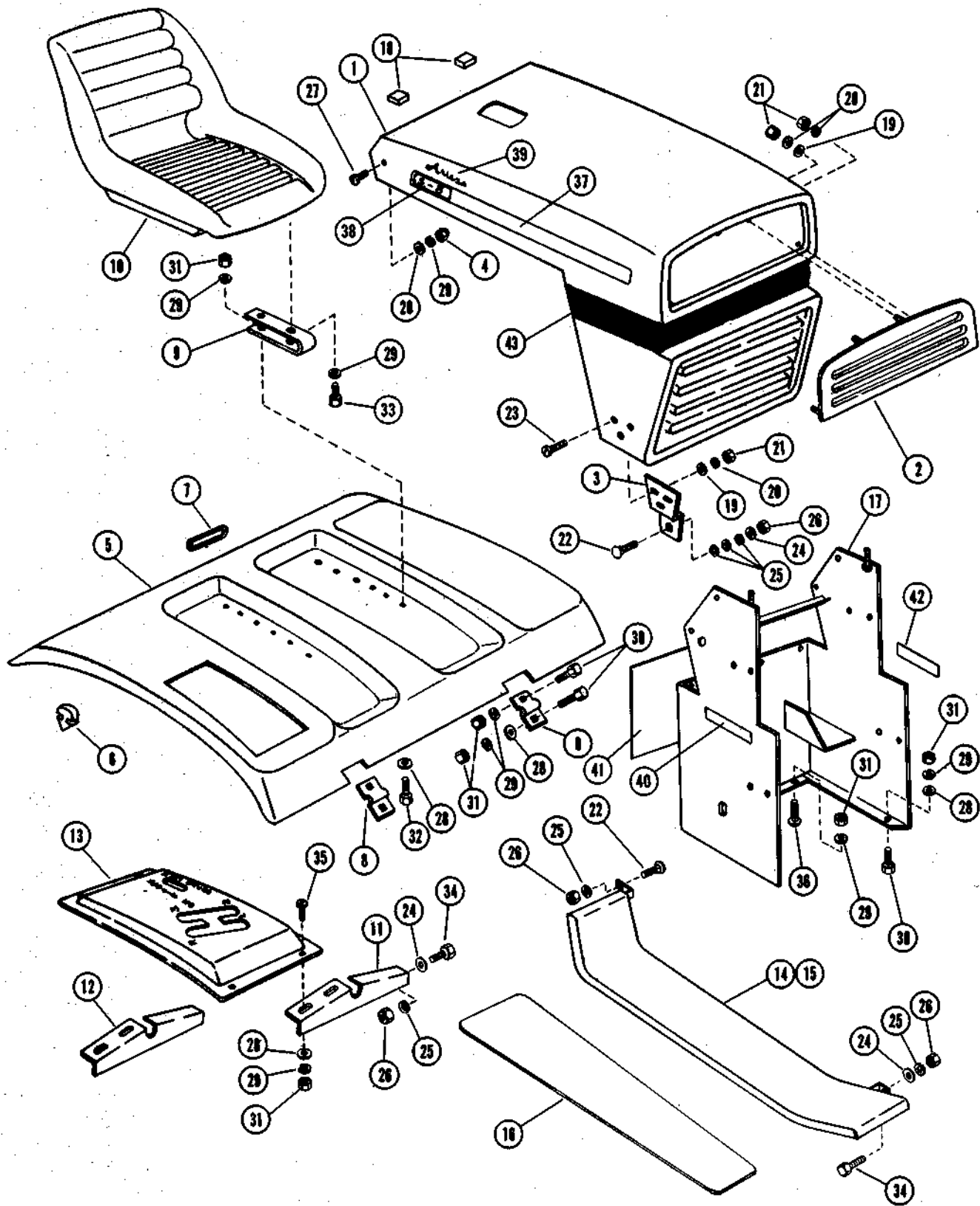

HOOD, REAR DECK, SEAT, DASH SUPPORT, RUNNING BOARD

REF NO.	PART NO.	DESCRIPTION	929001	929002
1	529007	HOOD (Gear)	1	
	529008	HOOD (Hydro)		1
2	029124	GRILL INSERT	1	1
3	029122	HINGE, Hood	2	2
4	065095	NUT, Crown 5/16" - 18	2	2
5	029119	REAR DECK	1	1
6	075054	BUMPER, Rubber	2	2
7	029134	REFLECTOR, Tail	1	1
8	029123	HINGE	2	2
9	029038	SPRING	2	2
10	029127	SEAT	1	1
11	029107	SUPPORT, Front	1	1
12	029106	SUPPORT, Rear	1	1
13	029120	CONSOLE, (Gear)	1	
	029121	CONSOLE (Hydrostatic)		1
14	529001	RUNNING BOARD, L.H.	1	1
15	529002	RUNNING BOARD, R.H.	1	1
16	029174	MAT, Carpet	2	2
17	529006	BASE (Gear)	1	
	529005	BASE (Hydro)		1
18	075058	STOP (Pressure Sensitive Backing)	2	2
19	064007	WASHER, Flat, 1/4"	8	8
20	063002	LOCKWASHER, 1/4"	10	10
21	065032	NUT, Hex, 1/4" - 20	10	10
22	062029	BOLT, Carriage, 3/8" - 16 x 1"	6	6
23	061041	SCREW, Machine, 1/4" - 20 x 5/8"	6	6
24	064008	WASHER, Flat, 3/8"	10	10
25	063021	LOCKWASHER, 3/8"	18	18
26	065018	NUT, Hex, 3/8" - 16	14	14
27	061045	SCREW, Machine, 5/16" - 18 x 1/2"	2	2
28	064002	WASHER, Flat, 5/16"	14	14
29	063003	LOCKWASHER, 5/16	22	22
30	059022	CAP SCREW, HH, 5/16" - 18 x 3/4"	6	6
31	065015	NUT, Hex, 5/16" - 18	16	16
32	059003	CAP SCREW, HH, 5/16" - 18 x 1"	4	4
33	059135	CAP SCREW, HH, 5/16" x 18 x 3/4" Grade 5	4	4
34	059004	CAP SCREW, HH, 3/8" - 16 x 1"	8	8
35	061042	SCREW, Machine, 5/16" - 18 x 3/4"	4	4
36	062011	BOLT, Carriage, 5/16" - 18 x 3/4"	2	2
37	78262	L.H. HOOD DECAL (Gear)	1	
	78268	L.H. HOOD DECAL (Hydrostatic)		1
	78261	R.H. HOOD DECAL (Gear)	1	
	78267	R.H. HOOD DECAL (Hydrostatic)		1
38	78260	L.H. S-8 DECAL	1	1
	78259	R.H. S-8 DECAL	1	1
39	78244	ARIENS NAME PLATE	2	2
40	78279	ATTACHMENT DRIVE DECAL	1	1
41	78276	CAUTION DECAL (Gear)	1	
	78274	CAUTION DECAL (Hydrostatic)		1
42	78277	ATTACHMENT DECAL	1	1
43	78272	STRIPE DECAL	1	1

REAR WHEELS & AXLE, BELT & DRIVE-HYDROSTATIC

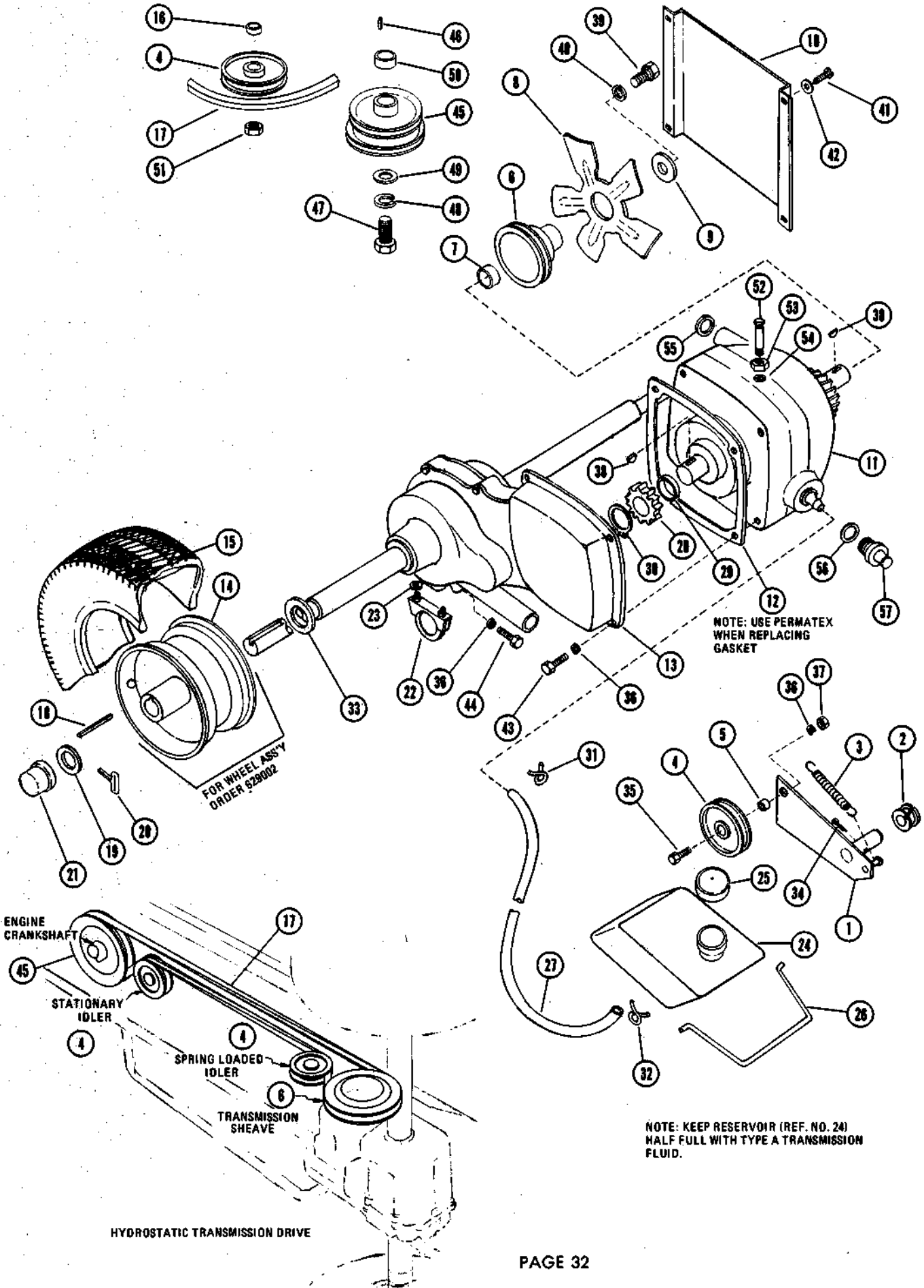

HYDROSTATIC TRANSMISSION DRIVE

REAR WHEELS & AXLE, BELT & DRIVE-HYDROSTATIC

REF NO.	PART NO.	DESCRIPTION	929002	REF NO.	PART NO.	DESCRIPTION	929002
1	029040	IDLER ARM	1	29	029143	SPACER	1
2	055077	BEARING, Nylon	2	30	057061	RING, Retaining	1
3	083111	SPRING	1	31	057052	CLAMP, Spring	1
4	073054	IDLER	2	32	069096	CLAMP, Spring	1
5	029141	SPACER	1	33	064110	WASHER	2
6	029041	SHEAVE	1	34	067006	PIN, Cotter, 3/16" x 1-1/4"	1
7	029142	SPACER	1	35	059027	CAP SCREW, HH, 3/8" - 16 x 1-3/4"	1
8	029043	FAN	1	36	063021	LOCKWASHER, 3/8"	7
9	064099	WASHER, Special	1	37	065018	NUT, Hex, 3/8" - 16	1
10	029042	SHIELD	1	38	066006	KEY, Woodruff, No. 3	2
† 11	629010	DRIVE ASS'Y HYDROSTATIC	1	39	059132	CAP SCREW, HH, 1/4" - 20 x 1	1
12	029044	GASKET	1	40	063002	LOCKWASHER, 1/4"	1
*13		TRANSMISSION (Tecumseh No. 1309)	1	41	074040	SCREW, Self Tapping, 5/16" x 1/2"	4
	629002	WHEEL ASS'Y, Rear Consists of:	2	42	064123	WASHER, Flat, 5/16"	4
14		071102 RIM	1	43	059141	CAP SCREW, HH, 3/8" - 16 x 3" Grade 5	4
15		071101 TIRE, 20 x 8.00-10	1	44	059023	CAP SCREW, HH 3/8" - 16 x 3/4"	2
16	029160	SPACER	1	45	029105	SHEAVE	1
17	072102	"V" BELT (Hydrostatic)	1	46	066026	KEY, Square, 1/4" x 1/4" x 2-1/2"	1
18	066018	KEY, Square, 1/4" x 1/4" x 1-3/4"	2	47	059142	CAP SCREW, HH, 7/16" - 20 x 1"	1
19	064029	WASHER, Special	2	48	063005	LOCKWASHER, 7/16"	1
20	067027	COTTER, "T" Head	2	49	064103	WASHER, Special	1
21	029173	CAP, Grease	2	50	029139	SPACER	1
22	023077	"U" BOLT & CLAMP ASS'Y	2	51	065098	LOCKNUT, 3/8" - 16	1
23	064002	WASHER, Flat, 5/16"	2	52	029217	DUMP VALVE	1
24	029045	RESERVOIR, Oil	1	53	029215	NUT, W/Gasket	1
25	029001	CAP	1	54	056078	"O" RING	1
26	029138	CLIP	1	55	056079	OIL SEAL	1
27	029135	HOSE	1	56	029216	GASKET	1
28	029046	SPUR GEAR	1	57	029214	ADAPTOR	1

*The transmission is to be serviced and warranted by Tecumseh Products.

† Assembly includes Ref. No. 52 thru 57

REAR WHEELS & AXLE, BELT & DRIVE -GEAR

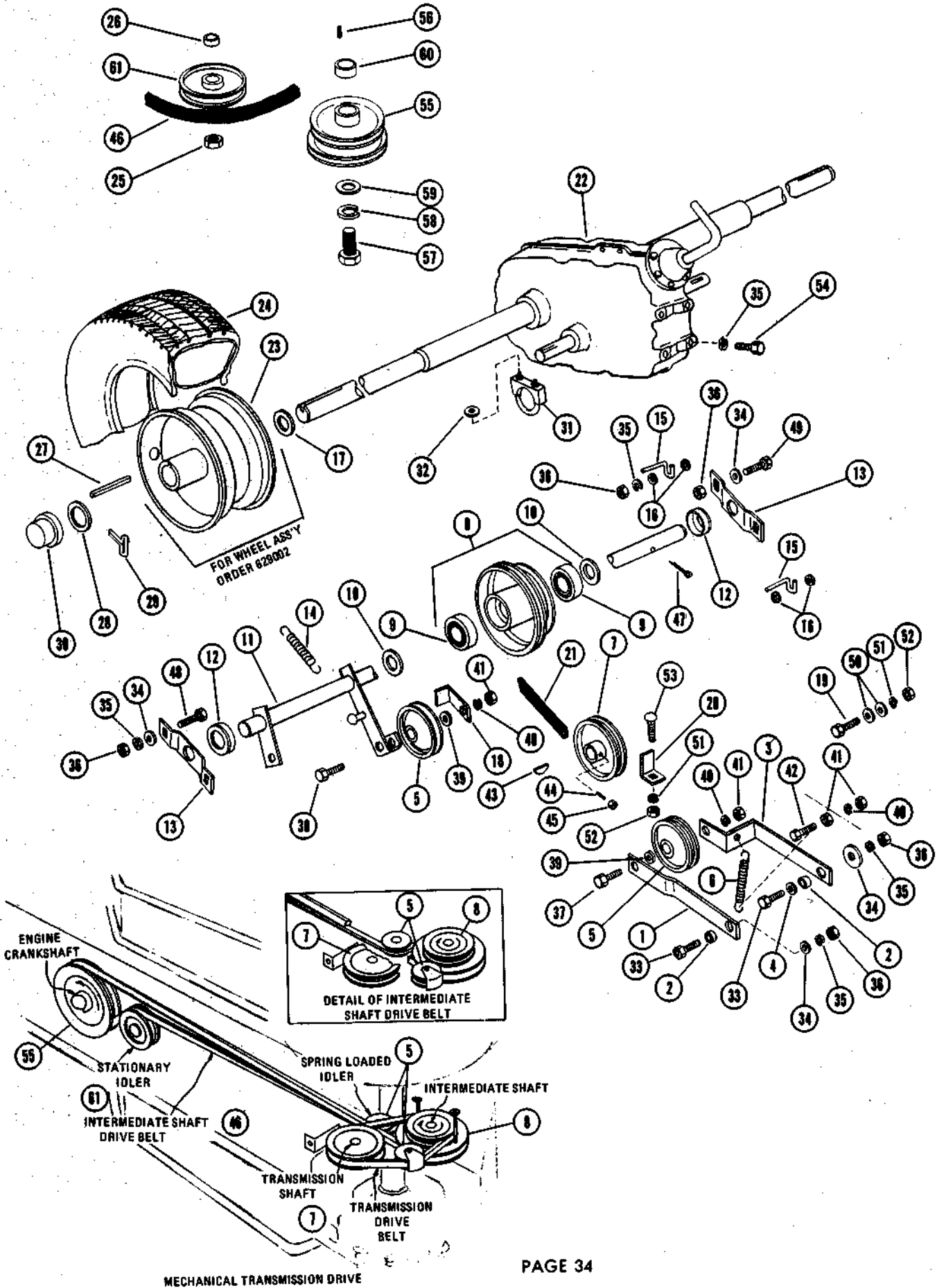

REAR WHEELS & AXLE, BELT & DRIVE -GEAR

REF NO.	PART NO.	DESCRIPTION	929001	REF NO.	PART NO.	DESCRIPTION	929001
1	029028	IDLER ARM	1	33	059005	CAP SCREW, HH, 3/8" - 16 x 1-1/4"	2
2	029140	SPACER	2	34	064008	WASHER, Flat, 3/8"	6
3	029029	IDLER ARM	1	35	063021	LOCKWASHER, 3/8"	8
4	064101	WASHER, Special	1	36	065018	NUT, Hex, 3/8" - 16	8
5	073101	IDLER	2	37	059143	CAP SCREW, HH, 1/2" x 2-1/4" Gr. 5	1
6	083110	SPRING	1	38	059058	CAP SCREW, HH, 1/2" - 13 x 3-1/4"	1
7	073040	SHEAVE	1			Grade 5	
8	629003	SHEAVE W/Ball Bearing	1	39	064120	WASHER, Flat, 1/2"	2
9	054073	BALL BEARING	2	40	063006	LOCKWASHER, 1/2"	3
10	064108	SPACER, Washer	3	41	065021	NUT, Hex, 1/2" - 13	4
11	029034	IDLER PIVOT	1	42	059144	CAP SCREW, HH, 1/2" - 13 x 2-1/2"	1
12	055077	BEARING, Nylon	2			Grade 5	
13	029035	SUPPORT	2	43	066003	KEY, Woodruff, No. 9	1
14	083117	SPRING	1	44	060030	SCREW, Hex Socket, 1/4" - 20 x 5/8"	2
15	029039	BELT GUIDE	2	45	065099	NUT, Hex Jam, 1/4" - 20	2
16	064102	WASHER, Special	4	46	072103	"V" BELT	1
17	064110	WASHER	2	47	067006	PIN, Cotter, 3/16" x 1-1/4"	1
18	029036	BELT GUIDE	1	48	059004	CAP SCREW, 3/8" - 16 x 1"	2
19	059022	CAP SCREW, HH, 5/16" - 18 x 3/4"	1	49	059158	BOLT, Tap, 3/8" - 16 x 1-3/4"	2
20	029031	STRAP	1	50	064002	WASHER, Flat, 5/16"	2
21	072100	"V" BELT	1	51	063003	LOCKWASHER, 5/16"	2
*22		TRANSAXLE: Tecumseh No. 1212	1	52	065015	NUT, Hex, 5/16" - 18	2
	629002	WHEEL ASS'Y, Rear, Consists of		53	062011	BOLT, Carriage, 5/16" - 18 x 3/4"	1
23		071102 RIM	1	54	059023	CAP SCREW, HH, 3/8" - 16 x 3/4"	2
24		071101 TIRE, 20 x 8.00 - 10	1	55	029105	SHEAVE	1
25	065098	LOCKNUT, 3/8" - 16	1	56	066026	KEY, Square, 1/4" x 1/4" x 2-1/2"	1
26	029160	SPACER	1	57	059142	CAP SCREW, HH, 7-1/16" - 20 UNF	1
27	066018	KEY, Square, 1/4" x 1/4" x 1-3/4"	2			x 1"	
28	064029	WASHER, Special	2	58	063005	LOCKWASHER, 7/16"	1
29	067027	COTTER, "T" Head	2	59	064103	WASHER, Special	1
30	029173	CAP, Grease	2	60	029139	SPACER	1
31	023077	CLAMP ASS'Y	2	61	073054	IDLER	1
32	064002	WASHER, Flat, 5/16"	2				

*The Transaxle is to be serviced and warranted by Tecumseh Products

SHIFT CONTROL & LINKAGE -HYDROSTATIC

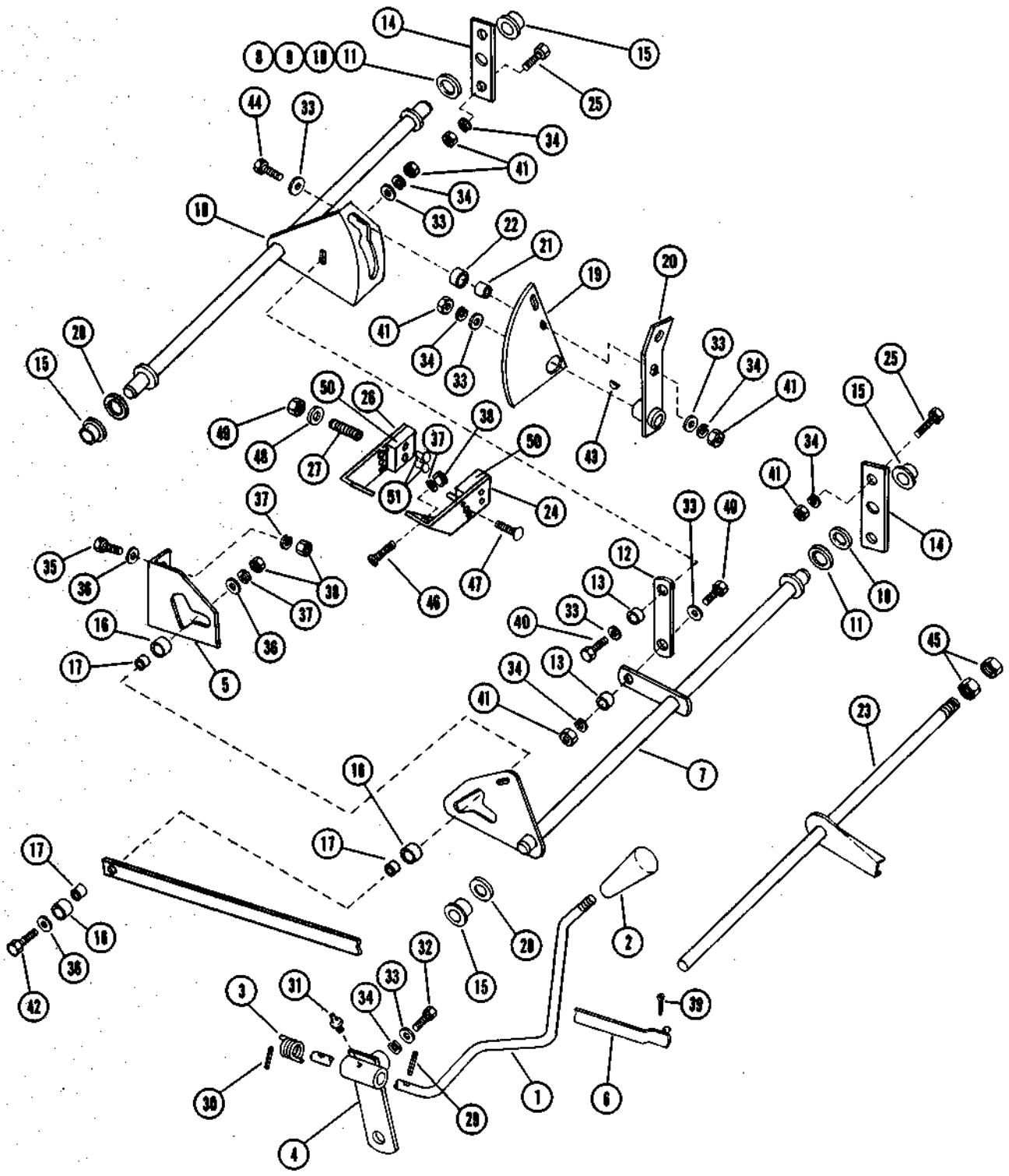

SHIFT CONTROL & LINKAGE -HYDROSTATIC

REF NO.	PART NO.	DESCRIPTION	929002	REF NO.	PART NO.	DESCRIPTION	929002
1	029061	SHIFT LEVER	1	28	064009	WASHER, Flat, 3/4"	2
2	075049	HANDLE	1	29	058019	PIN, Grooved, 3/16" x 1 Type E	1
3	083112	SPRING, Tension	1	30	058049	PIN, Grooved, 3/16" x 1-1/4" Type E	1
4	029055	PIVOT ASS'Y	1	31	022093	FITTING, Grease, 1/4" - 28	1
5	028062	BRACKET	1	32	059023	CAP SCREW, HH, 3/8" - 16 x 3/4"	1
6	029057	LINK	1	33	064008	WASHER, Flat, 3/8"	7
7	029053	NEUTRALIZER	1	34	063021	LOCKWASHER, 3/8"	9
8	064117	SHIM, 005 Thick	2	35	059003	CAP SCREW, HH, 5/16" - 18 x 1"	2
9	064118	SHIM, 010 Thick	1	36	064002	WASHER, Flat, 5/16"	4
10	064119	SHIM, 025 Thick	3	37	063003	LOCKWASHER, 5/16"	5
11	064108	SHIM, Washer	2	38	065015	NUT, Hex, 5/16" - 18	5
12	029064	ARM	1	39	067024	PIN, Cotter, 1/8" x 3/4"	1
13	029159	SPACER	2	40	059005	CAP SCREW, HH, 3/8" - 16 x 1-1/4"	2
14	029056	PLATE	2	41	065018	NUT, Hex, 3/8" - 16	8
15	055080	BUSHING	4	42	059073	CAP SCREW, HH, 5/16" - 18 x 1-3/4"	1
16	029066	ROLLER	3	43	066006	KEY, Woodruff, No. 3	1
17	029065	SPACER	3	44	059027	CAP SCREW, HH, 3/8" - 16 x 1-3/4"	1
18	029052	CAM	1	45	065098	LOCKNUT, Hex, 3/8" - 16	2
19	029063	PLATE	1	46	062011	BOLT, Carriage, 5/16" - 18 x 1-3/4"	2
20	029060	LEVER	1	47	062030	BOLT, Carriage, 1/4" - 20 x 3-1/2"	1
21	029160	WASHER, Spacer	1	48	064007	WASHER, Flat, 1/4"	1
22	029068	SPACER	1	49	065070	LOCKNUT, Hex, 1/4" - 20	1
23	029054	LEVER	1	50	029220	LINING	2
24	629033	FRONT DRAG BRKT.	1	51	068053	RIVET	4
25	059004	CAP SCREW, HH, 3/8" - 16 x 1"	4				
26	629032	REAR DRAG BRKT.	1				
27	083115	SPRING	1				

SHIFT CONTROL & LINKAGE -GEAR

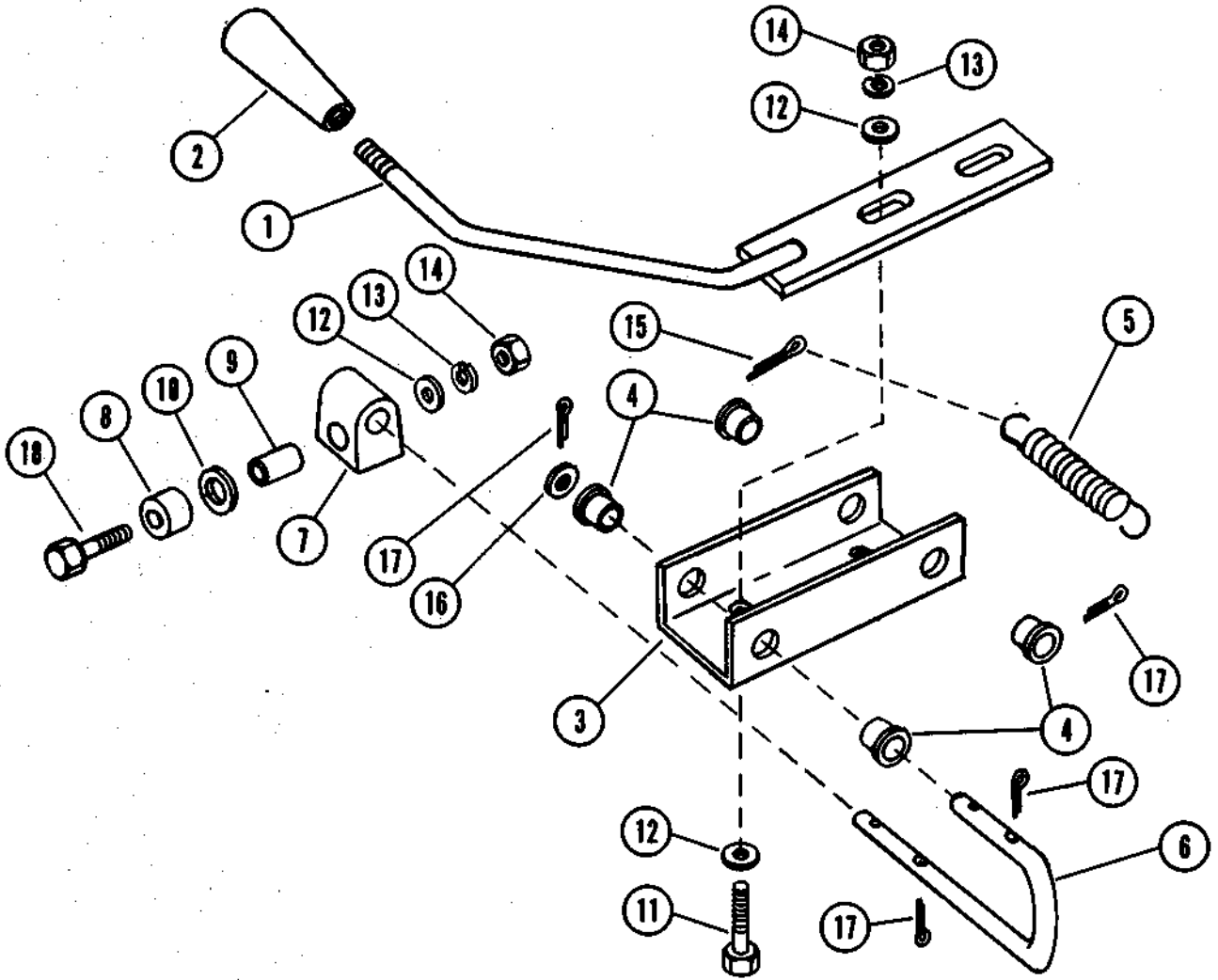

REF NO.	PART NO.	DESCRIPTION	929001
1	029047	LEVER ASSEMBLY	1
2	075049	HANDLE	1
3	029048	CHANNEL	1
4	055078	BUSHING, Nylon	4
5	083116	SPRING	1
6	029049	ROD	1
7	029050	PIVOT	1
8	029051	SPACER	1
9	029025	SPACER, Bushing	1
10	064104	WASHER, Special	1
11	059003	CAP SCREW, HH, 5/16" - 18 x 1"	2
12	064002	WASHER, Flat, 5/16"	5
13	063003	LOCKWASHER, 5/16"	3
14	065015	NUT, Hex, 5/16" - 18	3
15	067021	PIN, Cotter, 1/8" x 1-1/2"	1
16	064121	WASHER, Flat, 7/16"	6
17	067004	PIN, Cotter, 1/8" x 1"	5
18	059074	CAP SCREW, HH, 5/16" - 18 x 2-3/4"	1

BRAKE & PARKING BRAKE

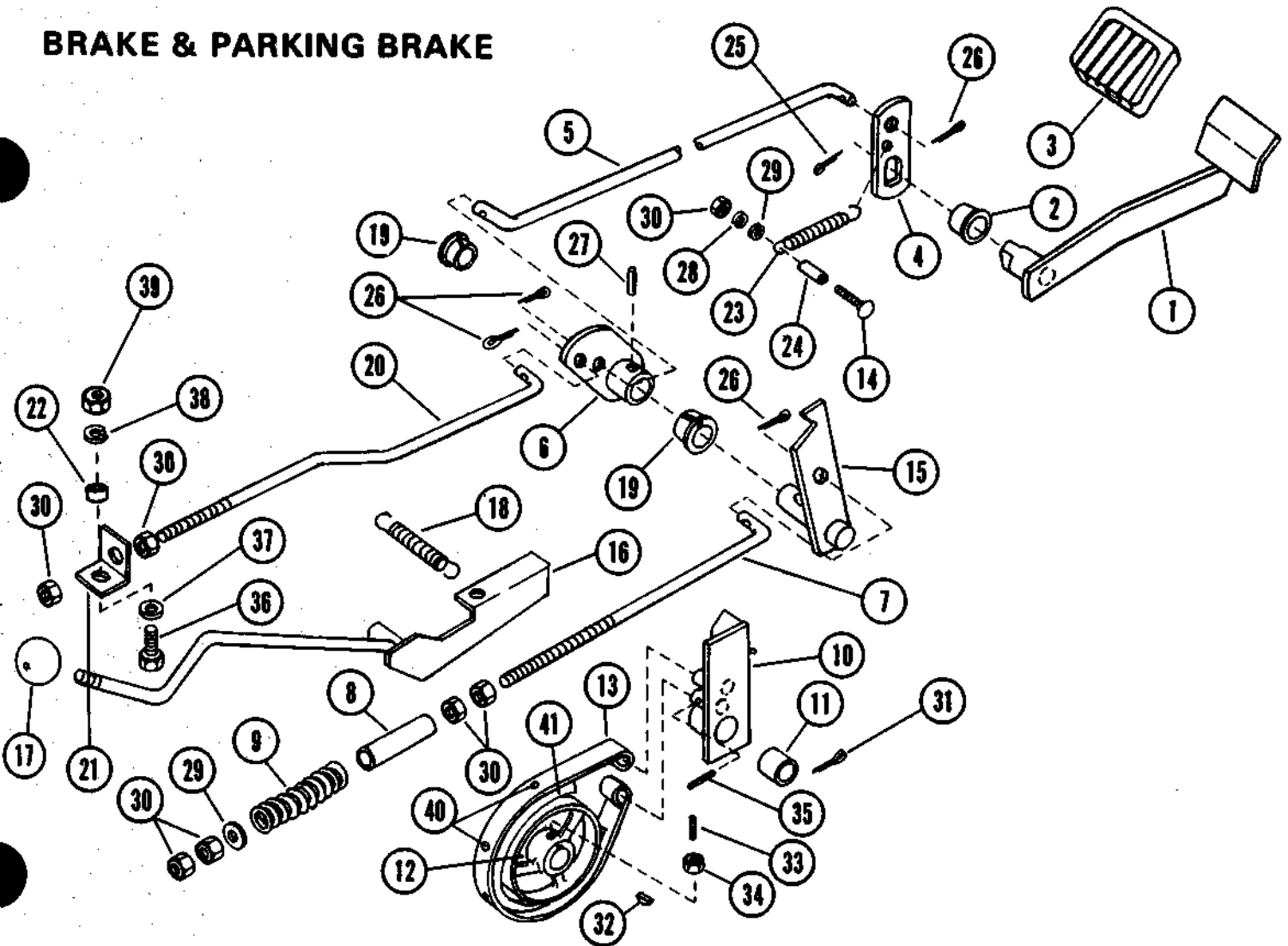

REF NO.	PART NO.	DESCRIPTION	929001	929002	REF NO.	PART NO.	DESCRIPTION	929001	929002
1	029067	BRAKE PEDAL	1	1	22	029161	BUSHING	1	
2	055081	BEARING, Nylon	1	1	23	083117	SPRING	1	1
3	075051	PAD, Pedal	1	1	24	029144	SPACER BUSHING	1	1
4	029081	ARM	1	1	25	067021	PIN, cotter, 1/8" x 1-1/2"	1	1
5	029076	ROD	1	1	26	067024	PIN, Cotter, 1/8" x 3/4"	4	3
6	029069	ARM	1	1	27	058049	PIN, Grooved, 3/16" x 1-1/4" Type E	1	1
7	029078	BRAKE ROD	1	1	28	063003	LOCKWASHER, 5/16"	1	1
8	029079	SPACER	1	1	29	064002	WASHER, Flat, 5/16"	2	2
9	083113	SPRING, Compression	1	1	30	065015	NUT, Hex, 5/16" - 18	7	5
10	029070	BRAKE PIVOT (Gear)	1		31	067002	PIN, Cotter, 3/32" x 1"	1	1
	029071	BRAKE PIVOT (Hydrostatic)		1	32	066003	KEY, Woodruff, No. 9	1	1
11	055024	BUSHING	1	1	33	060030	SCREW, Hex Socket, 1/4" - 20 x 5/8"	1	1
12	029037	BRAKE DRUM	1	1	34	065099	NUT, Hex Jam, 1/4" - 20	1	1
13	629034	BRAKE BAND, W/Lining	1	1	35	058019	PIN, Grooved, 3/16" x 1" Type E	2	2
14	062023	BOLT, Carriage 5/16" - 18 x 1-1/2"	1	1	36	059005	CAP SCREW, 3/8" - 16 x 1-1/4"	1	1
15	029072	ARM	1	1	37	064008	WASHER, Flat, 3/8"	1	
16	029073	BRAKE LOCK	1	1	38	063021	LOCKWASHER, 3/8"	1	
17	075052	KNOB	1	1	39	065018	NUT, Hex, 3/8" - 16	1	
18	083109	SPRING	1	1	40	068054	RIVET	4	4
19	055077	BEARING, Nylon	2	2	41	029219	LINING	1	1
20	029077	ROD	1						
21	029080	ANGLE	1						

PTO LINKAGE, BELT & SHEAVE

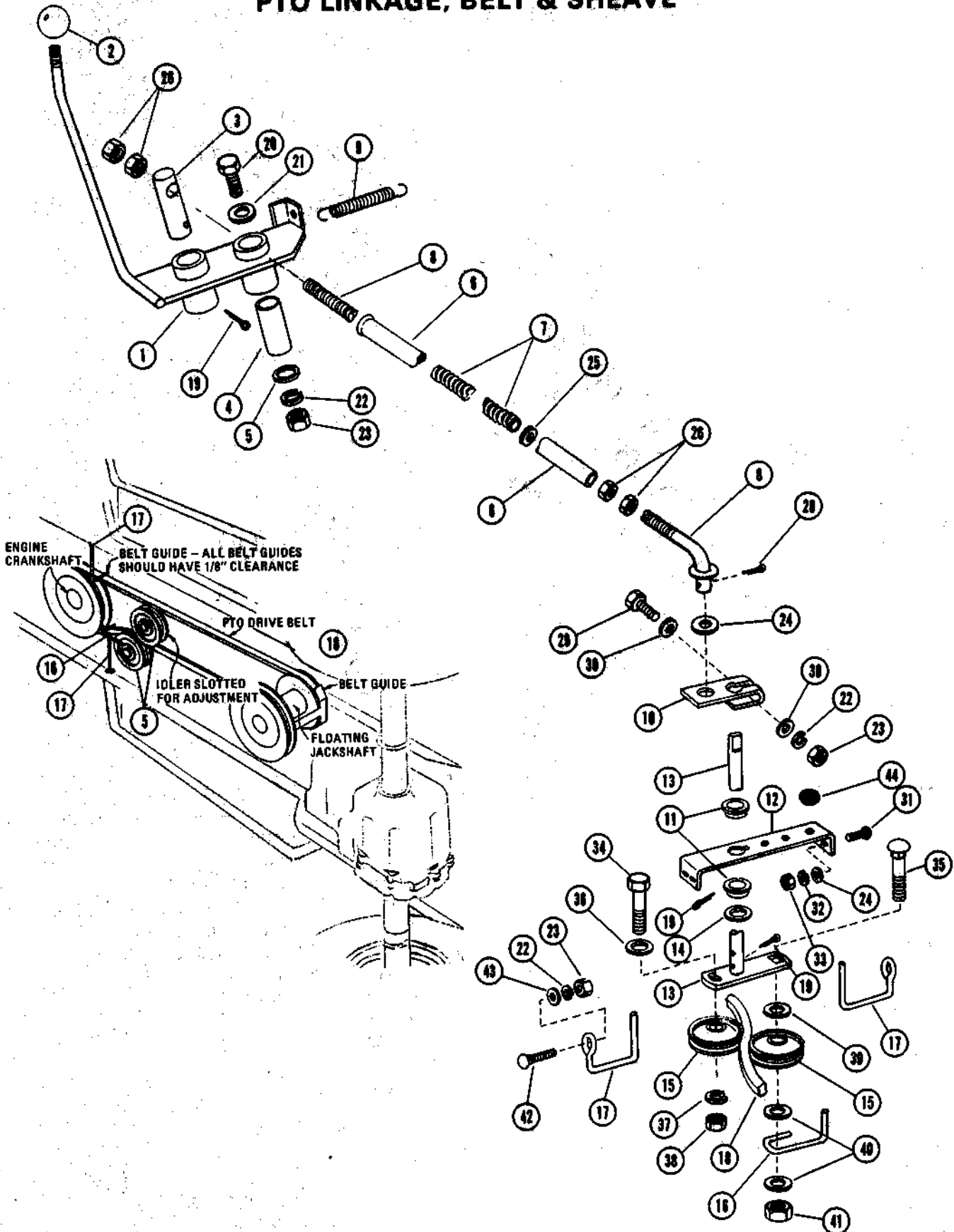

PTO LINKAGE, BELT & SHEAVE

REF NO.	PART NO.	DESCRIPTION	929001	929002
1	029098	HANDLE	1	1
2	075052	KNOB	1	1
3	029104	PIN	1	1
4	029103	SPACER	1	1
5	064105	WASHER, Special	1	1
6	029102	GUIDE TUBE	1	1
7	083114	SPRING	1	1
8	029097	ROD	1	1
9	083118	SPRING	1	1
10	029101	CLEVIS	1	1
11	055084	BUSHING	2	2
12	029100	SUPPORT	1	1
13	029099	IDLER PIVOT	1	1
14	064100	WASHER, Special	1	1
15	073101	IDLER	2	2
16	029136	BELT FINGER	1	1
17	029137	BELT FINGER	2	2
18	072101	"V" BELT	1	1
19	067004	PIN, Cotter, 1/8" x 1"	3	3
20	059149	CAP SCREW, HH, 3/8" - 16 x 2-1/4" Grade 5	1	1
21	064008	WASHER, Flat, 3/8"	1	1
22	063021	LOCKWASHER, 3/8"	5	4
23	065018	NUT, Hex, 3/8" - 16	4	4
24	064007	WASHER, Flat, 1/4"	2	2
25	064002	WASHER, Flat, 5/16"	1	1
26	065015	NUT, Hex, 5/16" - 18	4	4
27	065061	NUT, Hex Jam, 5/16" - 18	1	1
28	067016	PIN, Cotter, 5/32" x 1"	1	1
29	059068	CAP SCREW, HH, 3/8" - 16 x 2"	1	1
30	064069	WASHER, Flat, 3/8"	2	2
31	062012	BOLT, Carriage, 1/4" - 20 x 3/4"	4	4
32	063002	LOCKWASHER, 1/4"	4	4
33	065032	NUT, Hex, 1/4" - 20	4	4
34	059041	CAP SCREW, HH, 1/2" - 13 x 2-1/4"	1	1
35	062006	BOLT, Carriage, 1/2" - 13 x 2-1/2"	1	1
36	064120	WASHER, Flat, 1/2"	1	1
37	063006	LOCKWASHER, 1/2"	1	1
38	065021	NUT, Hex, 1/2"	1	1
39	064107	WASHER, Special	1	1
40	064116	WASHER, Flat, 1/2"	2	2
41	065097	LOCKNUT, Hex, 1/2" - 13	1	1
42	062029	BOLT, Carriage, 3/8" - 16 x 1"	2	2
43	064102	WASHER, Special	2	2
44	075055	GROMMET	1	1

HAND LIFT & SHEAVE

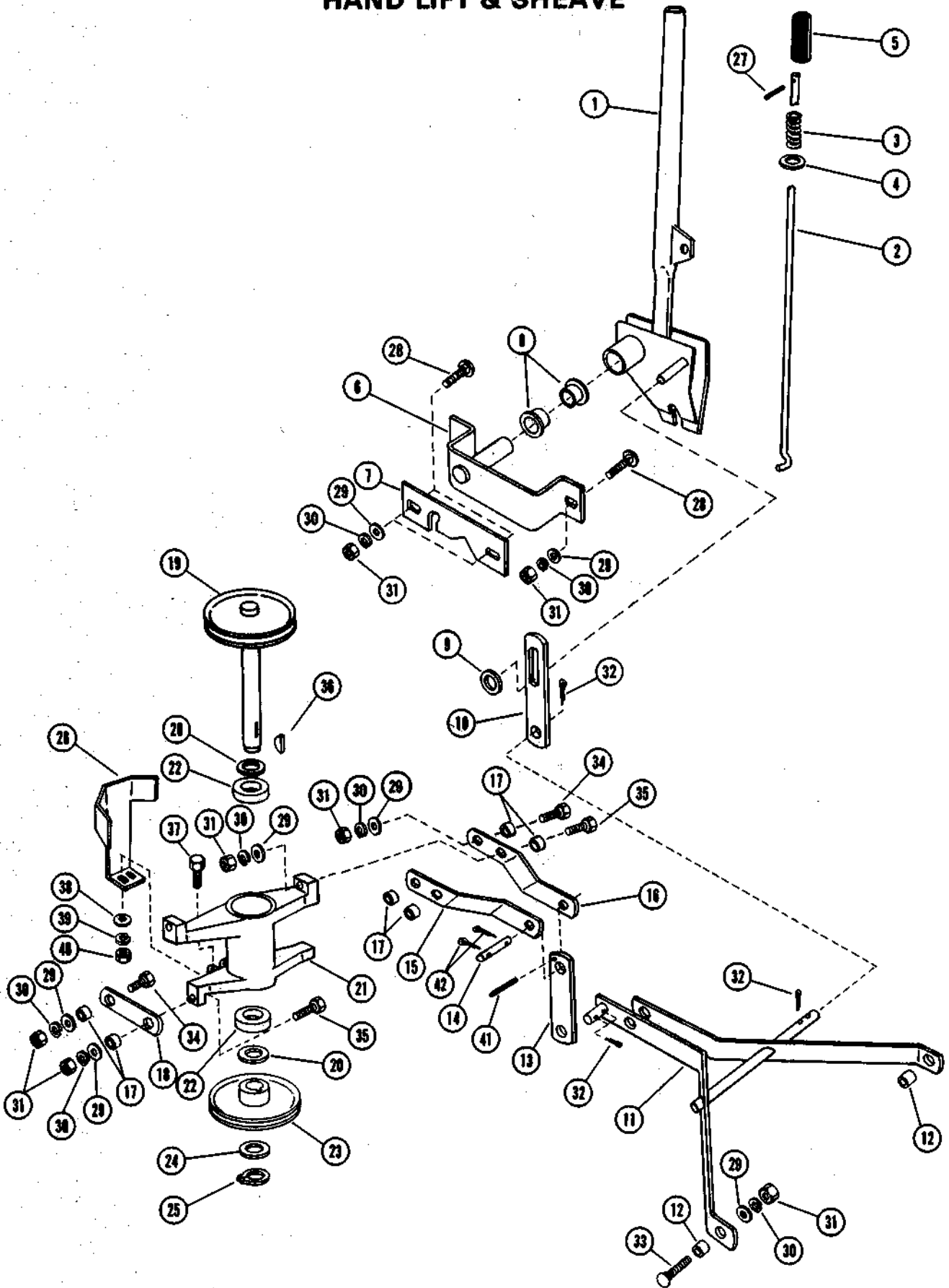

HAND LIFT & SHEAVE

REF NO.	PART NO.	DESCRIPTION	929001	929002
1	029082	LIFT LEVER	1	1
2	029083	ROD	1	1
3	083104	SPRING	1	1
4	064096	WASHER, Special	1	1
5	075053	GRIP	1	1
6	029084	BRACKET	1	1
7	029090	LIFT PLATE	1	1
8	055082	BUSHING, Nylon	2	2
9	064097	WASHER, Special	1	1
10	029091	STRIP	1	1
11	029088	LIFT	1	1
12	029141	SPACER	2	2
13	029092	LINK	1	1
14	029096	PIN	1	1
15	029093	LINK, R.H.	1	1
16	029094	LINK, L.H.	1	1
17	029161	BUSHING	8	8
18	029095	LINK	2	2
19	029085	SHEAVE	1	1
20	064098	WASHER	2	2
21	029089	BEARING HOUSING	1	1
22	054073	BALL BEARING	2	2
23	029086	SHEAVE, PTO	1	1
24	064108	WASHER, Special	2	2
25	057012	SNAP RING	1	1
26	029087	BELT GUIDE	1	1
27	058034	ROLL PIN, 1/8" x 3/4"	1	1
28	062029	BOLT, Carriage 3/8" - 16 x 1"	4	4
29	064008	WASHER, Flat, 3/8"	14	14
30	063021	LOCKWASHER, 3/8"	14	14
31	065018	NUT, Hex, 3/8" - 16	14	14
32	067004	PIN, Cotter, 1/8" x 1"	4	4
33	062016	BOLT, Carriage, 3/8" - 16 x 1-1/4"	2	2
34	059004	CAP SCREW, HH, 3/8" - 16 x 1"	4	4
35	059005	CAP SCREW, HH, 3/8" x 16 x 1-1/4"	4	4
36	066003	KEY, Woodruff, No. 9	1	1
37	059003	CAP SCREW, HH, 5/16" - 18 x 1"	2	2
38	064002	WASHER, Flat, 5/16"	2	2
39	063003	LOCKWASHER, 5/16"	2	2
40	065015	NUT, Hex, 5/16" - 18	2	2
41	068050	PIN, Groove, 1/4" x 1-1/4" Type E	1	1
42	067002	COTTER PIN, 3/32" x 1"	2	2

DASH, DASH CONTROLS & ELECTRICAL

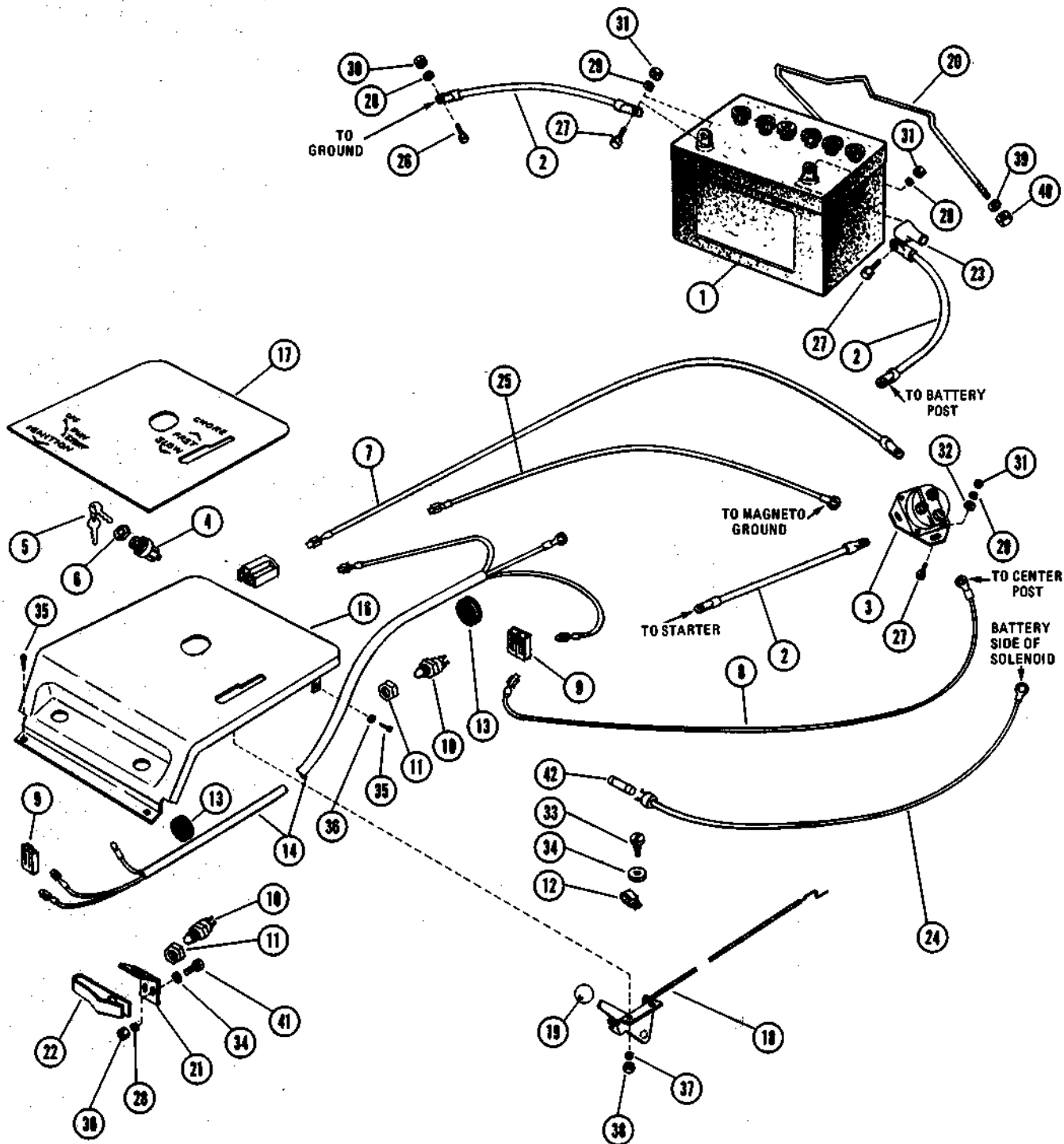

DASH, DASH CONTROLS & ELECTRICAL

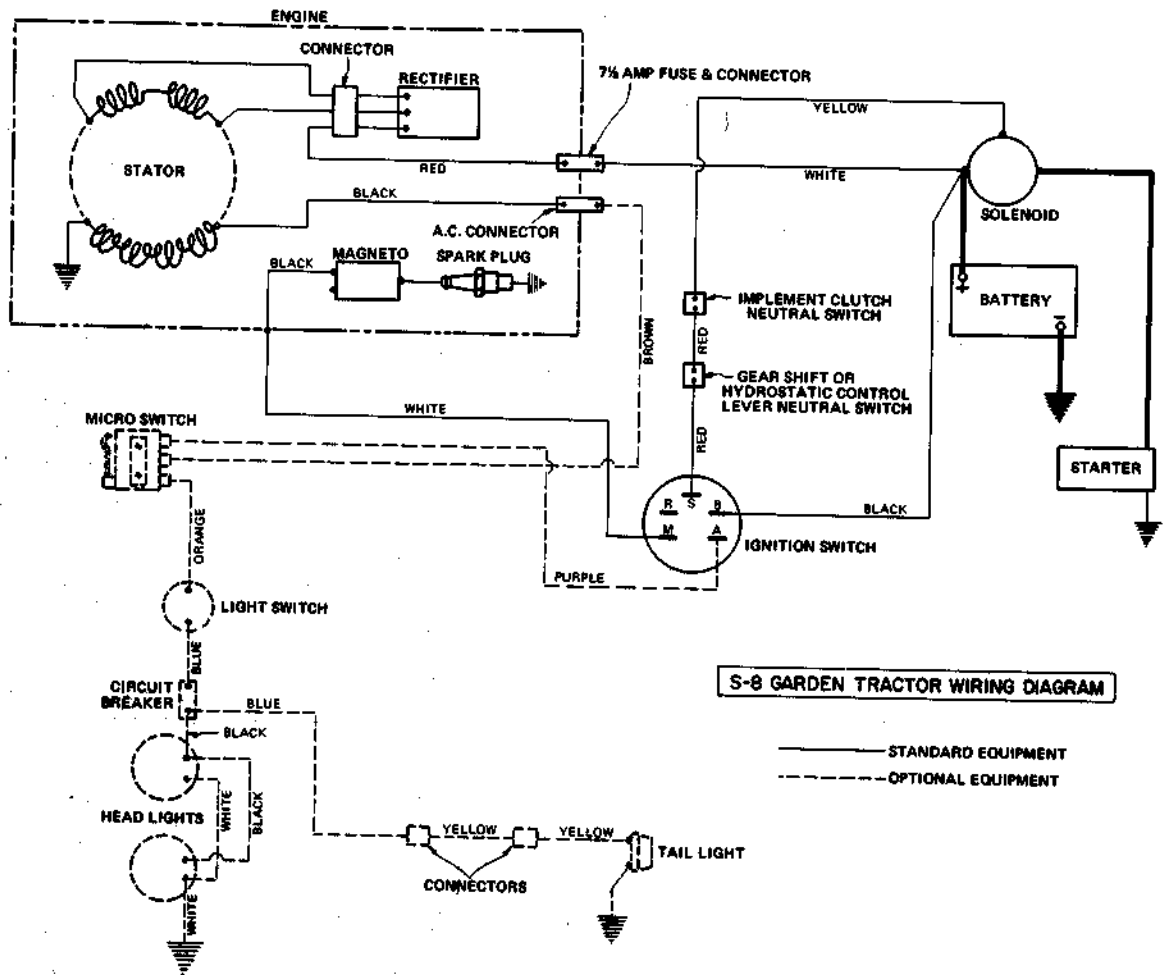

REF. NO.	PART NO.	DESCRIPTION	929001	929002
1	029175	BATTERY, 12 Volt	1	1
2	029026	CABLE	3	3
3	029132	SOLENOID	1	1
4	029149	SWITCH, Ignition	1	1
5	013157	KEY SET	1	1
6	065108	NUT, Special, 9/16" - 24	1	1
7	029167	WIRE ASS'Y, 29" long Black	1	1
8	029169	WIRE ASS'Y, 24" long, Yellow	1	1
9	029170	CONNECTOR HOUSING, 2 Wire	2	2
10	029131	SWITCH, Safety	2	2
11	065096	NUT, Special, 9/16" - 18 UNF	2	2
12	069094	CLIP	4	4
13	075055	GROMMET	2	2
14	029166	WIRE HARNESS (Mechanical)	1	
15	029165	WIRE HARNESS (Hydrostatic)		1
16	529003	DASH W/Decal	1	1
17	078205	DASH Decal	1	1
18	069095	THROTTLE CONTROL	1	1
19	075056	KNOB	1	1
20	029128	ROD, Battery Hold Down	1	1
21	029129	BRACKET, Safety Sw. (Hydrostatic)	1	
22	029130	ACTUATOR, Safety Sw. (Hydros.)	1	

REF. NO.	PART NO.	DESCRIPTION	929001	929002
23	075057	INSULATOR	1	1
24	029164	WIRE	1	1
25	029168	WIRE 14" long, White	1	1
26	059022	CAP SCREW, 5/16" - 18 x 3/4"	1	1
27	059001	CAP SCREW, HH, 1/4" - 20 x 3/4"	4	4
28	063003	LOCKWASHER, 5/16"	3	1
29	063002	LOCKWASHER, 1/4"	4	4
30	065015	NUT, Hex, 5/16" - 18	3	1
31	065032	NUT, Hex, 1/4" - 20	4	4
32	064007	WASHER, Flat, 1/4"	2	2
33	074040	SCREW, Self Tapping 5/16" x 1/2"	1	1
34	064002	WASHER, Flat, 5/16"	3	1
35	074043	SCREW, Self Tapping, RH, 10 - 29 x 1/2"	5	5
36	064122	WASHER, Flat, No. 8 1/4" ID x 5/8" OD	2	2
37	063011	LOCKWASHER, No. 10	2	2
38	065055	NUT, Hex, No. 10 - 24	2	2
39	064123	WASHER, Flat, 5/16"	2	2
40	065095	LOCKNUT, Hex, 5/16" - 18	2	2
41	059003	CAP SCREW, HH, 5/16" - 18 x 1"	2	2
42	013198	FUSE	1	1

ROTARY MOWER - 36RM - 829001

SERIAL NUMBER 000301 AND UP

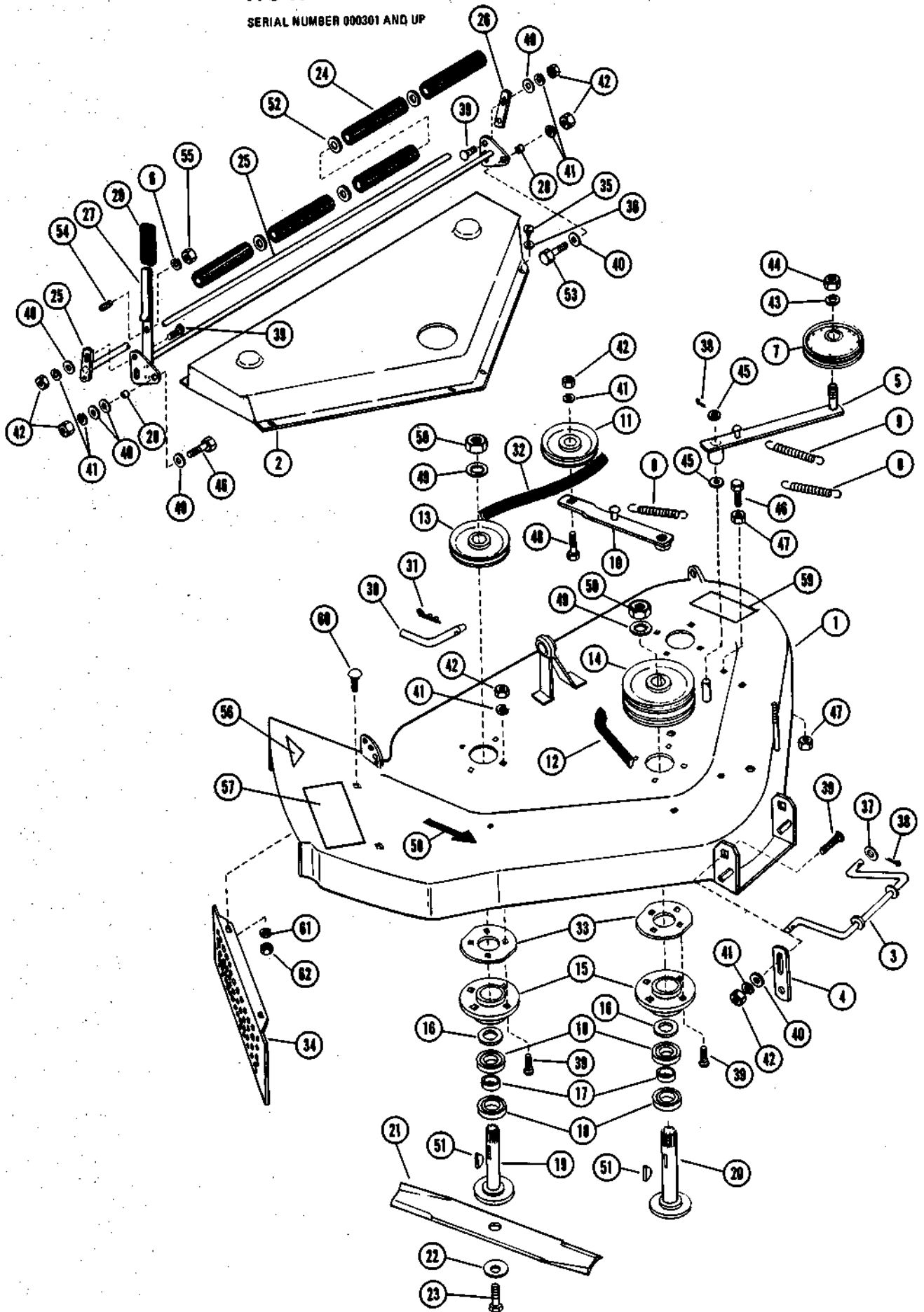

ROTARY MOWER - 36RM - 829001

SERIAL NUMBER 000301 AND UP

REF NO.	PART NO.	DESCRIPTION	REF NO.	PART NO.	DESCRIPTION		
1	529004	MOWER DECK, 36"	33	029177	SHIM		
2	029146	SHIELD	* 34	729004	MULCHER KIT	9	
3	029153	SUPPORT	35	074076	SCREW, Self Tapping H.H. 1/4" x 1/2"	6	
4	029176	LINK	36	064007	WASHER, Flat, 1/4"	6	
5	029152	IDLER ARM	37	064100	WASHER, Special	2	
6	063011	LOCKWASHER, No. 10	38	067004	PIN, Cotter, 1/8" x 1"	1	
7	073059	IDLER	39	062029	BOLT, Carriage, 3/8" - 16 x 1"	16	
8	083117	SPRING	40	064008	WASHER, Flat, 3/8"	8	
9	083127	SPRING	41	063021	LOCKWASHER, 3/8"	19	
10	029151	IDLER ARM	42	065018	NUT, Hex, 3/8" - 16	19	
11	073054	IDLER	43	063006	LOCKWASHER, 1/2"	1	
12	072078	"V" BELT	44	065021	NUT, Hex, 1/2" - 13	1	
13	073053	SHEAVE	45	064003	WASHER, Flat, 1/2"	2	
14	029154	SHEAVE	46	059005	CAPSCREW, H.H. 3/8" - 16 x 1-1/4"	2	
15	031044	FLANGE	47	065001	NUT, Hex, Jam, 3/8" - 16	2	
16	064048	WASHER, Special	48	062016	BOLT, Carriage, 3/8" - 16 x 1-1/4"	1	
17	031144	SPACER, Split (445 Thick)	49	063027	LOCKWASHER, Int, Tooth 3/4"	3	
18	054073	BEARING, Ball	50	065016	NUT, Hex, Jam, 3/4" - 16 UNF	3	
19	029156	SHAFT, Outside	51	066003	KEY, Woodruff, No. 9	3	
20	029155	SHAFT, Center	52	064011	WASHER, Flat, 5/8"	4	
21	029157	BLADE	53	059004	CAPSCREW, HH. 3/8" - 16 x 1"	1	
22	031191	WASHER, Special	54	059156	CAPSCREW, Socket Hd. No. 10-24 x 3/8"	1	
23	059153	CAPSCREW, Hex 7/16" - 20 x 1" UNF Gr. 5	55	065055	NUT, Hex, No. 10 - 24	1	
24	031141	ROLLER	56	78226	SAFETY LABEL	1	
25	029150	SHAFT	57	78271	CAUTION DECAL	1	
26	031156	LINK	58	78270	CUTTING WIDTH DECAL	1	
27	629019	ADJUSTER, Roller	59	78269	CAUTION DECAL (Rotating Parts)	1	
28	029161	BUSHING	*Mulcher Kit Consists of Mulcher Plate and the Following Hardware:				
29	075069	GRIP	60	062035	BOLT CARRIAGE, 3/8" x 3/4"	2	
30	029178	PIN	61	063021	LOCKWASHER, 3/8"	2	
31	067029	HAIRPIN COTTER	62	065018	NUT, Hex, 3/8" - 16	2	
32	072077	"V" BELT					

MODEL 829003 36 ST SNOW THROWER ATTACHMENT

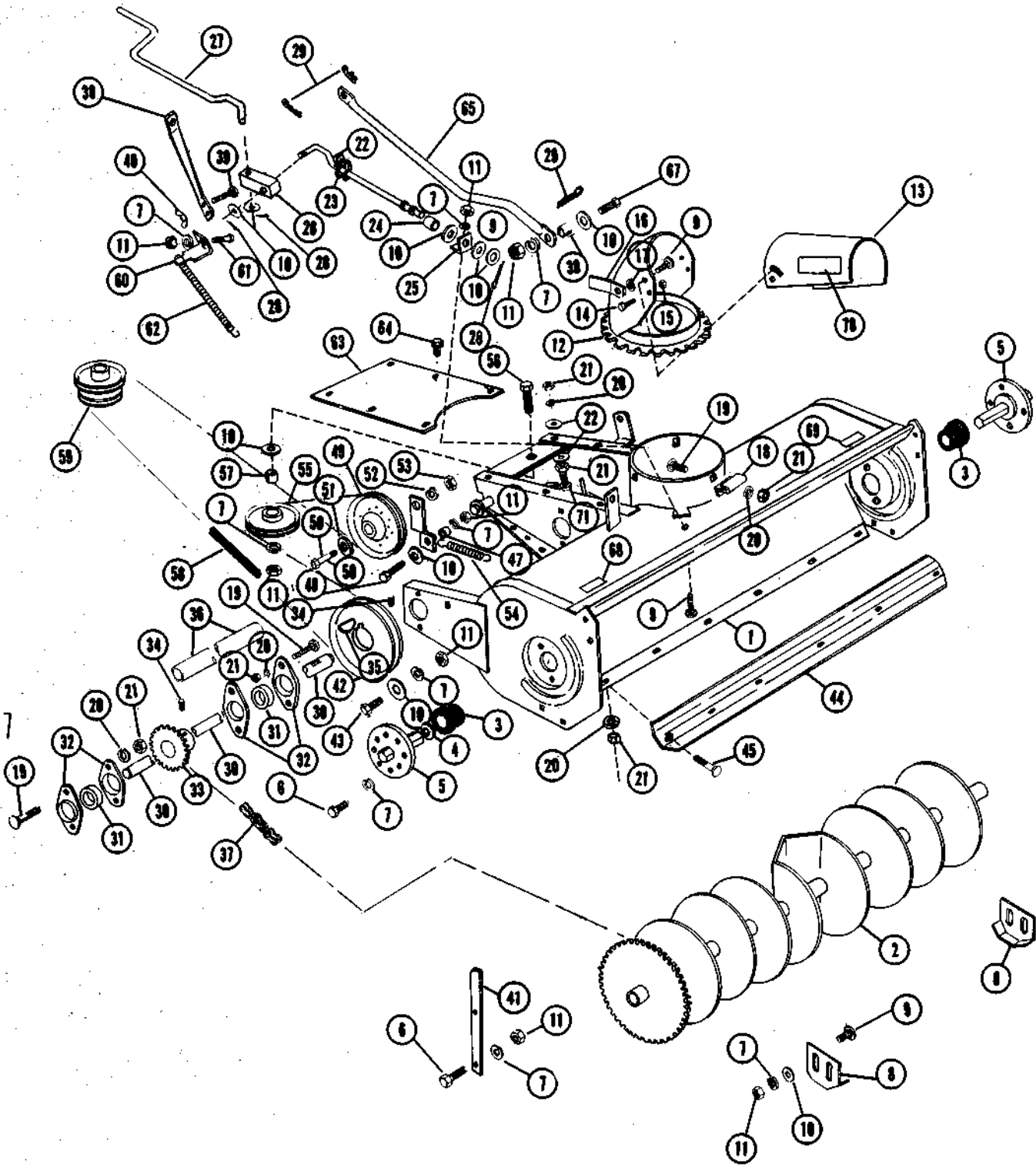

MODEL 829003 36 ST SNOW THROWER ATTACHMENT

REF NO.	PART NO.	DESCRIPTION	829003	REF NO.	PART NO.	DESCRIPTION	829003
1	529011	AUGER HOUSING W/Decal	1	37	029250	CHAIN	1
2	029223	AUGER	1	38	029237	SUPPORT	1
3	054111	BEARING	2	39	062028	CARRIAGE BOLT, 3/8-16 x 1"	2
4	064009	WASHER, Flat, 3/4"	AR	40	065023	WING NUT, 3/8-16	2
5	029224	MOUNTING PLATE	2	41	029239	BAR	2
6	059154	CAP SCREW, 3/8-16 x 3/4, H.H. Gr. 5	8	42	029240	SHEAVE	1
7	063021	LOCKWASHER, 3/8"	19	43	059160	CAP SCREW, 3/8-16 x 2-3/4" H.H. Gr. 5	1
8	029225	SKID SHOE	2	44	029241	WEAR PLATE	1
9	062010	CARRIAGE BOLT, 3/8-16 x 3/4"	7	45	062011	CARRIAGE BOLT, 5/16-18 x 3/4	6
10	064008	WASHER, Flat, 3/8"	16	46	029242	BRACKET	1
11	065018	NUT, Hex, 3/8-16	16	47	029161	SPACER BUSHING	1
12	029226	SHROUD	1	48	059145	CAP SCREW, 3/8-16 x 1" H.H. Gr. 5	1
13	529010	DEFLECTOR W/Decal	1	49	073066	IDLER	1
14	059155	CAP SCREW, 1/4-20 x 1/2" H.H. Gr. 5	2	50	059143	CAP SCREW, 1/2-13 x 2-1/4, H.H. Gr. 5	1
15	065070	LOCKNUT, Crown, 1/4-20	2	51	064003	WASHER, Flat, 1/2"	2
16	029229	LOCKING LEVER	2	52	063006	LOCKWASHER, 1/2"	1
17	064147	WASHER, Special	2	53	065021	NUT, Hex, 1/2-13	1
18	029228	SPOUT RING HOLDER	3	54	083127	EXTENSION SPRING	1
19	062034	CARRIAGE BOLT, 5/16-18 x 3/4"	7	55	029244	SHEAVE	1
20	063003	LOCKWASHER, 5/16"	15	56	059161	CAP SCREW, 3/8-16 x 1-3/4, H.H. Gr. 5	1
21	065015	NUT, Hex, 5/16-18	17	57	029245	SPACER	1
22	029230	DISC CONTROL COIL	1	58	072104	"V" BELT	1
23	083142	COMPRESSION SPRING	1	59	029221	SHEAVE	1
24	029231	SPLIT SPACER	1	60	029246	BRACKET	2
25	029232	BRACKET	1	61	059133	CAP SCREW, 3/8-16 x 1-1/4, H.H. Gr. 5	2
26	031268	UNIVERSAL BLOCK JOINT	1	62	083107	SPRING	2
27	029238	CHUTE CONTROL HANDLE	1	63	029247	COVER	1
28	067001	PIN, Cotter, 3/32 x 3/4	2	64	070015	FLANGE WHIZLOCK SCREW, 1/4-20 x 1/2	6
29	067029	HAIRPIN COTTER	3	65	029190	TUBE	1
30	029234	SHAFT	1	66	029189	SPLIT SPACER	1
31	054112	BEARING	2	67	059151	CAP SCREW, 3/8-16 x 1-1/2, H.H. Gr. 5	1
32	054113	FLANGETTE	4	68	078271	DECAL, Caution	1
33	029235	SPROCKET W/Setscrew	1	69	078244	SPRIPT NAME PLATE	1
34	060012	SETSCREW, 5/16-18 x 3/8 Nylok	6	70	078298	DECAL, Warning	1
35	066003	KEY, Woodruff No. 9	2	71	059128	CAP SCREW, 5/16-18 x 1-3/4, H.H. Gr. 5	2
36	029236	TUBE	1	72	064002	WASHER, Flat, 5/16"	4

ASSEMBLY

INSTALL ROLL PIN

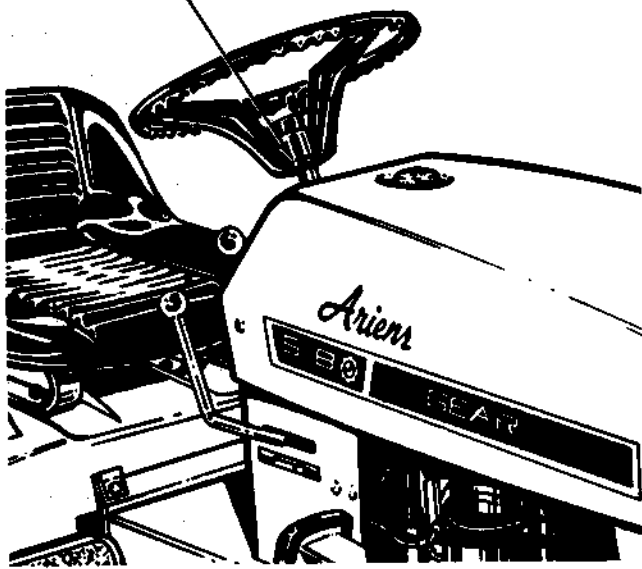

FIGURE 1

STEERING WHEEL

Install the steering wheel on the column and secure with a roll pin as shown in Figure 1.

SERVICE BATTERY

Remove the battery from the tractor. This will prevent any accidentally spilled electrolyte from damaging the tractor.

Electrolyte is not furnished with the tractor. Use only battery grade sulphuric acid electrolyte with 1.265 specific gravity plus or minus 0.005 corrected to 80°F.

Prepare battery as follows:

1. Remove vent plugs.
2. With battery removed from the tractor, fill each cell with electrolyte until electrolyte level rises to split ring at the bottom of the filler tube. DO NOT OVERFILL.



BE CAREFUL! ELECTROLYTE CONTAINS SULPHURIC ACID WHICH IS HARMFUL TO SKIN, EYES AND CLOTHING. HANDLE WITH EXTREME CARE. IF SPILLAGE OCCURS ON BODY OR CLOTHING, RINSE AT ONCE WITH WATER.

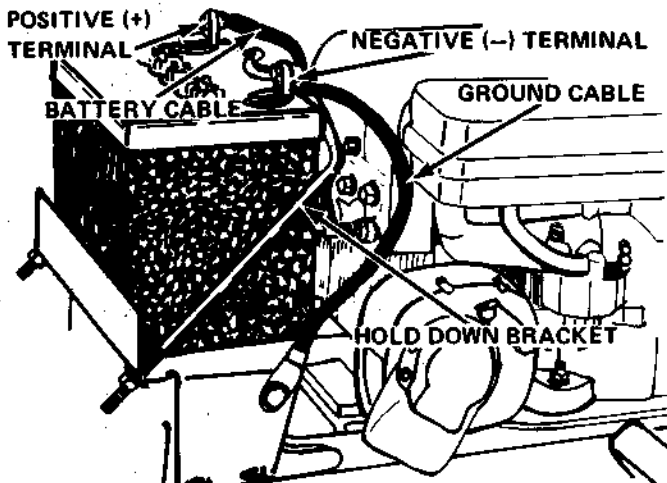

FIGURE 2

3. After filling cells, wait five to ten minutes and add additional electrolyte if necessary to bring electrolyte to proper level.

4. Charge battery with a 12-volt charger for 30 minutes at 4 to 6 amps.

5. After charging, add electrolyte until the level is up to the split ring in the filler tube. Thereafter, add only clean, distilled water as use and time requires.

6. Replace vent caps. Clean and dry battery exterior.

INSTALL BATTERY

Place the battery in the battery carrier as shown in Figure 2 with the positive (+) terminal to the right side of the tractor.

Secure the battery in place with the battery hold down as shown in Figure 3. Do not overtighten the hold-down nuts.

Attach the battery cable to the positive (+) terminal and the ground cable to the negative (-) terminal as shown in Figure 43. Tighten the cables to the terminals securely.

Coat the terminals and the battery cable ends with a light coat of grease or petroleum jelly to prevent corrosion.

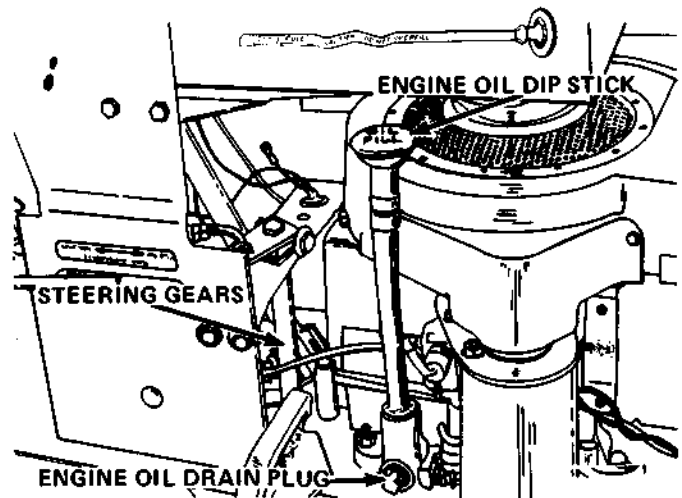

FIGURE 3

ENGINE OIL

Fill the engine crankcase (Figure 4). Use Ariens Gard-N-Yard MS 10W-30 oil when using lawn and garden attachments, use Ariens Sno-Thru oil (SAE 5W-20 MS classification) when using snow removal attachments.

Do not overfill — the oil level must never exceed the full mark.

TRANSMISSION OIL LEVEL (Gear Shift Model 929001)

Check the oil level using the following procedure:

1. Place tractor on a level surface.
2. Raise rear deck to gain access to the transmission check level plug.
3. Remove check plug, Figure 4. Oil should seep out of the check plug hole. If the level is too low, remove the filler plug and add Ariens MP-90 Premium Gear Lube (SAE 90-EP) weight transmission oil until the level is correct.

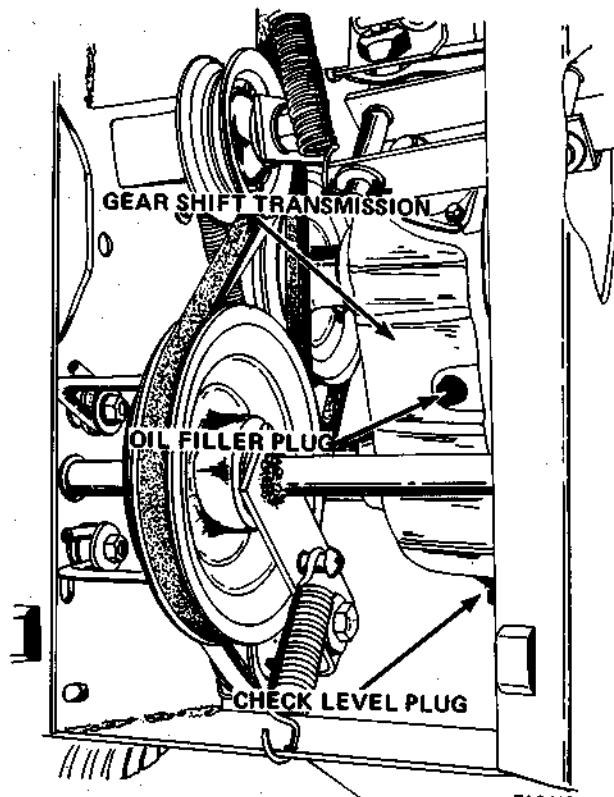

FIGURE 4

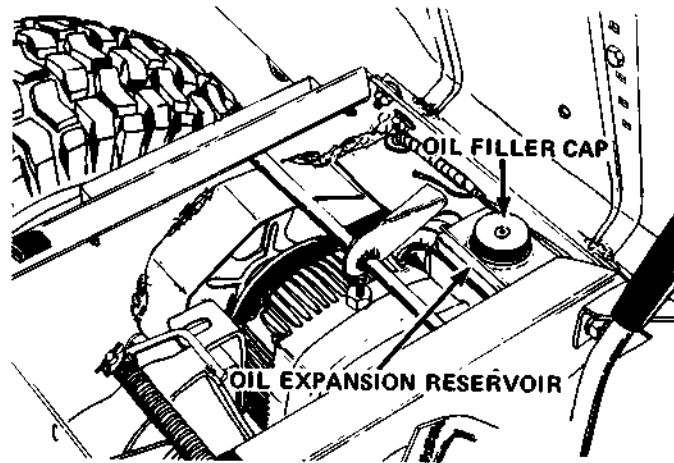

FIGURE 5

DIFFERENTIAL OIL LEVEL (Hydrostatic Models)

Check the differential oil level on hydrostatic tractors using the following procedure:

1. Place tractor on a level surface.
2. Remove the oil level and filler plug from the rear of the transmission, Figure 6.
3. Oil should reach the level and filler plug hole. If it does not, add Ariens Premium Gear Lube MP-90 (SAE 90-EP) until the proper level is reached.

4. Replace both the filler and the check plugs.

CAUTION: THE HYDROSTATIC TRANSMISSION AND THE DIFFERENTIAL ASSEMBLIES HAVE SEPARATE OIL RESERVOIRS. TYPE A TRANSMISSION FLUID MUST BE USED IN THE HYDROSTATIC TRANSMISSION AND ARIENS MP 90 PREMIUM GEAR LUBE (SAE 90-EP) MUST BE USED IN THE DIFFERENTIAL. IF IMPROPER OIL IS USED IN EITHER RESERVOIR, SERIOUS DAMAGE COULD OCCUR.



TRANSMISSION OIL LEVEL (Hydrostatic Models)

Check hydrostatic level using the following procedure:

1. Place tractor on a level surface.
2. Raise the rear deck and remove the oil filler cap shown in Figure 5.

CAUTION: THE AREA AROUND THE FILLER CAP MUST BE CLEAN BEFORE REMOVING THE CAP. DO NOT ALLOW ANY DIRT OR FOREIGN MATERIAL TO ENTER THE EXPANSION RESERVOIR.



3. Check oil level. The expansion reservoir should be $\frac{1}{2}$ full at ambient temperature. If required, add type A transmission fluid UNTIL THE RESERVOIR IS $\frac{1}{2}$ FULL.

CAUTION: IF OVERFILLED, THE OIL WILL EXPAND DURING OPERATION AND MAY LEAK OUT AROUND THE FILLER CAP.



If oil cannot be seen in the expansion reservoir, it will be necessary to fill the reservoir to the proper level and bleed (remove air) from the transmission. See Owner's Manual for this procedure.

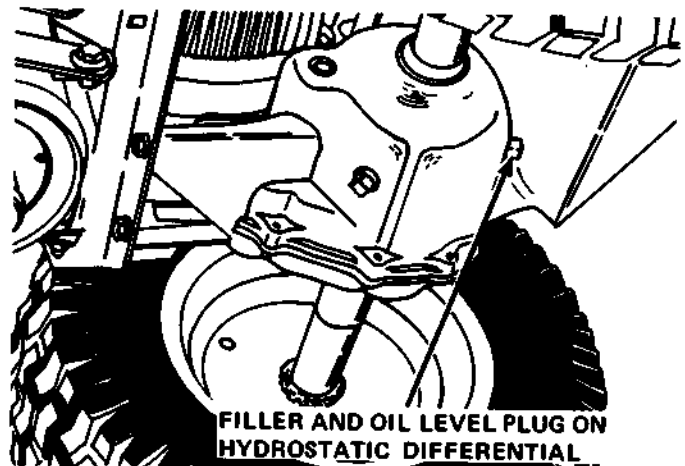

FIGURE 6

FILL FUEL TANK

Fill fuel tank with clean, fresh, regular grade gasoline. Do not use premium gasoline.

ADJUST TIRE PRESSURE

Tires are over-inflated for shipping purposes. Correct tire pressures are essential for proper handling or attachment performance. Adjust tire pressures as shown in the chart. Use a low pressure gauge for accurate readings.

DESCRIPTION	LAWN WORK	SNOW THROWER AND FRONT BLADE WORK
Front tires (15 x 6.00-6)	10	12
Rear tires (20 x 8.00-10)	6	6

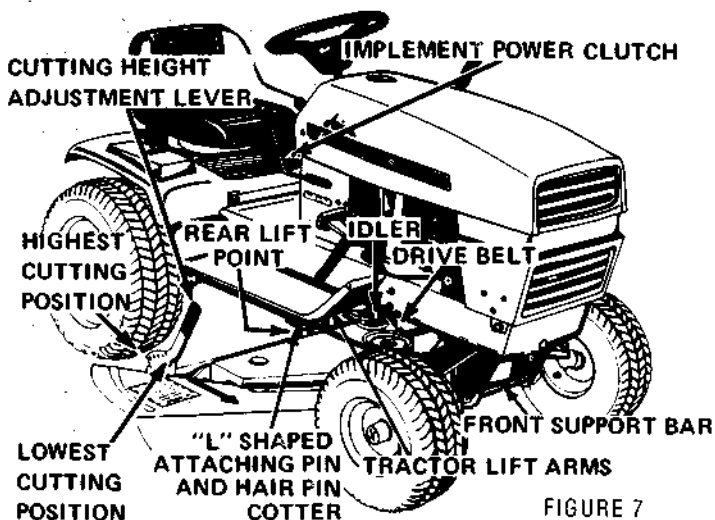

FIGURE 7

ASSEMBLE MOWER

1. Remove shipping straps from front support bar and belt idler.

ATTACH MOWER TO THE TRACTOR

Use the following procedure to attach the mower to the tractor:

1. Remove ignition key. Place implement power clutch lever in the disengaged position and engage the tractor brake lock.

2. Raise the tractor attachment lift lever.

3. Place cutting height adjustment lever in the second lowest cutting position as shown in Figure 7.

4. Raise front support bar to clear the front tractor tire and slide the mower under the tractor from the right side.

5. Place the drive belt over the rear lift point and lower the attachment lift lever. Align ball joint of rear lift point to tractor lift arms and secure with the "L" shape attaching pin and hairpin cotter provided. See Figure 7.

6. Position drive belt over the drive and driven sheaves and place idler to the inside of the belt as

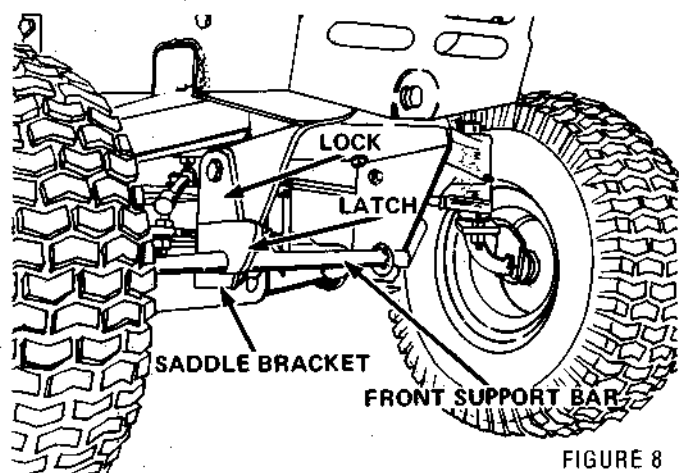

FIGURE 8

ADJUST BLADE LEVEL AND PITCH

IMPORTANT: ADJUST MOWER BLADE LEVEL AND PITCH AS OUTLINED IN THE OWNER'S MANUAL.



shown in Figure 7.

7. Position front support bar in the tractor saddle brackets and secure with the locks and latches as shown in Figure 8.

DELIVERY

Using the Owner's Manual as a guide, instruct the customer as follows:

1. Instruct the customer on the operation of the tractor. Emphasize safety and discuss the safety information in the Owner's Manual.

2. Advise customer to change oil in the engine crankcase after the first five hours of operation.

3. Advise customer to change the transmission oil filter after the first five hours of operation.

4. Explain how to perform the recommended lubrication and periodic service.

5. Explain maintenance and adjustment instructions.

6. Demonstrate how to mount and dismount attachments.

7. Make certain the customer has his Owner's Manual.

8. Explain Ariens Warranty Policy. Fill out and return Ariens Warranty Registration Card.

CONTROLS

① IMPLEMENT POWER CLUTCH — Figure 1

The implement power clutch is used to operate the mower or snow thrower. Push the lever forward to engage the clutch and drive the attachment. Pull the lever rearward to disengage the clutch and stop the attachment. The lever must be in the rear (disengaged) position to start the engine. THIS IS A SAFETY FEATURE. The engine will not start until the lever has been placed in the disengaged position.

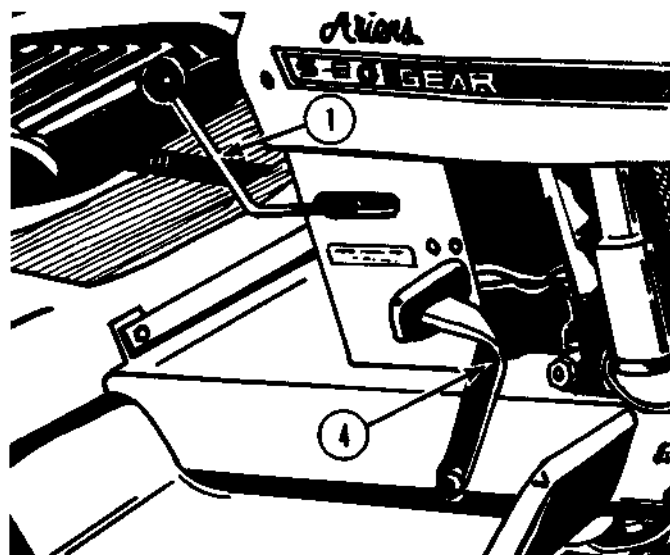

Figure 1

2 HYDROSTATIC CONTROL LEVER
(Hydrostatic Models — Figure 2)

This lever regulates both tractor speed and direction. Gradually move the lever forward from the "park-start" (neutral) position to increase forward travel speed. Move the lever rearward to the "R" position to back the tractor and regulate reverse speed.

NOTE: The lines and numbers next to the forward slot do not indicate a given speed. They serve as guidelines only.

THE CONTROL LEVER MUST BE IN THE "PARK-START" POSITION TO START THE ENGINE.

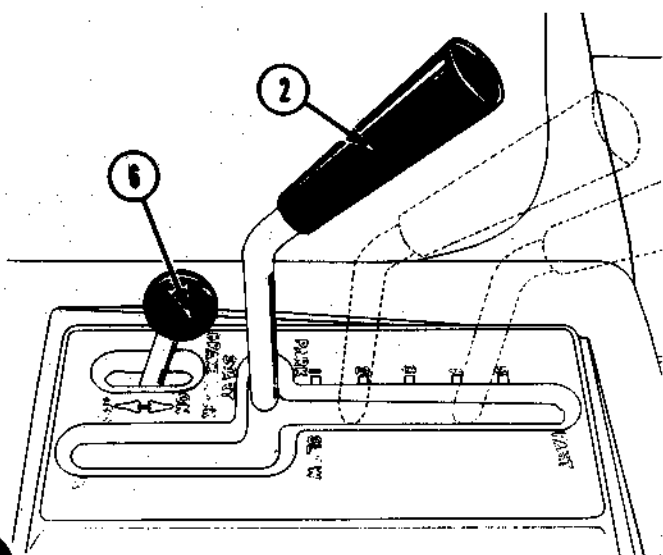

Figure 2

3 GEAR SHIFT LEVER (Gear Shift Models) — Figure 3

The gear shift lever is used to select any of three forward gears or one reverse gear. The markings 1, 2, 3 and R on the control console indicate the locations of the gears. The slowest forward gear is indicated by No. 1, the secondary gear, No. 2 and the fastest gear, No. 3. The "R" indicates reverse.

THE GEAR SHIFT LEVER MUST BE IN THE FORWARD NEUTRAL POSITION AS SHOWN IN FIGURE 3 TO START THE ENGINE.

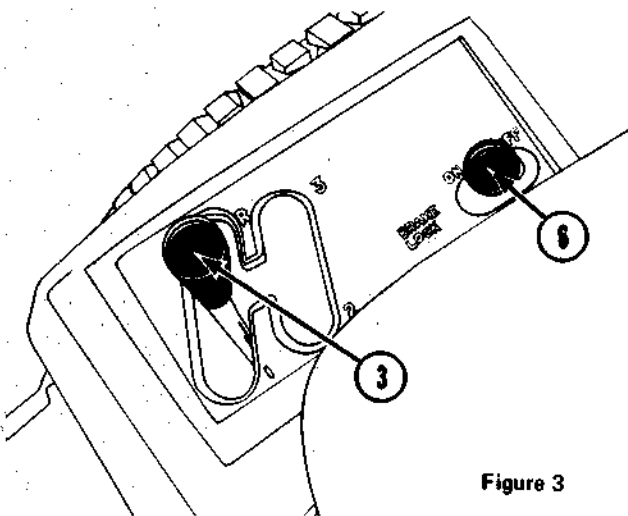

Figure 3

4 HYDROSTATIC NEUTRALIZER AND BRAKE PEDAL
(Hydrostatic Models) — Figure 1

When this pedal is depressed, the hydrostatic control lever will return to neutral and stop the forward or reverse motion of the tractor. At the same time, the pedal actuates an independent brake which provides an additional means of stopping the tractor.

NOTE: ALWAYS REMOVE HAND FROM HYDROSTATIC CONTROL LEVER BEFORE DEPRESSING THE NEUTRALIZER AND BRAKE PEDAL. THE TWO CONTROLS ARE INTERCONNECTED. OPERATING THEM SIMULTANEOUSLY COULD RESULT IN DAMAGED OR MISADJUSTED LINKAGE.

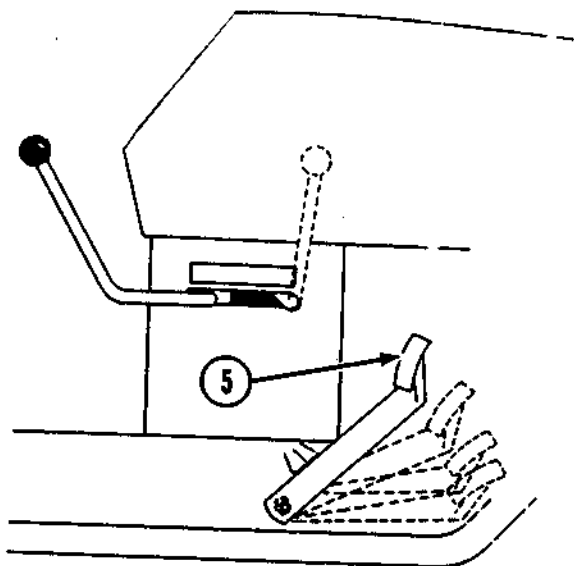

Figure 4

5 CLUTCH BRAKE PEDAL (Gear Shift Models) — Figure 4

The clutch-brake pedal performs two functions:

1. When depressed to the "midway" range the clutch disengages and the transmission can be shifted to any desired gear.
2. When the clutch-brake pedal is fully depressed, the brake actuates and stops the tractor.

NOTE: Always release the pedal slowly for smooth acceleration. Do not allow foot to rest on pedal except for clutching and braking functions.

6 BRAKE LOCK — Figures 2 and 3

A brake lock is provided on both hydrostatic and gear shift models to prevent the tractor from moving when parked or left unattended.

To lock the brake, push the brake lock forward with the foot pedal fully depressed. Then release the foot pedal. Figure 2 shows the brake lock engaged. Figure 3 shows it disengaged.

IMPORTANT: ENGAGE THE BRAKE LOCK BEFORE DISMOUNTING FROM THE TRACTOR OR ANY TIME IT IS LEFT UNATTENDED.

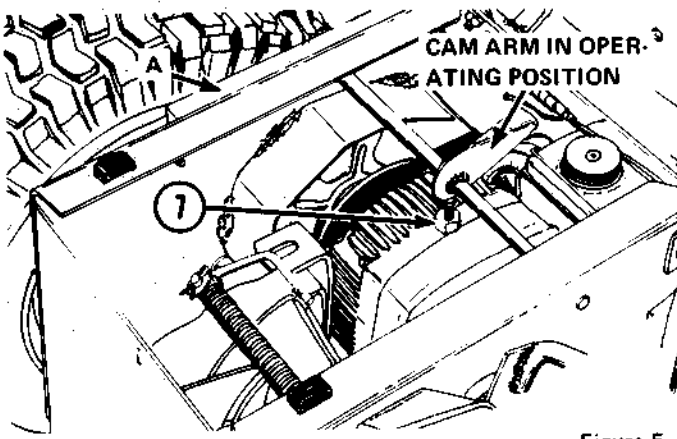

Figure 5

7 FREE-WHEELING VALVE (Hydrostatic Models) — Figure 5

The free-wheeling valve is provided so the tractor can be pushed short distances with the engine stopped.

The cam arm, see Figure 5, must be in the forward position as shown at all times except when it becomes necessary to push the tractor.

If it becomes necessary to move the tractor with the engine stopped, rotate the cam arm rearward so the valve actuating rod is pushed down into the transmission body. After moving the tractor the cam arm must be returned to the operating position before the tractor will move with the engine running.

IMPORTANT: DO NOT TOW TRACTOR AS INTERNAL TRANSMISSION DAMAGE COULD RESULT.

8 IGNITION AND STARTER SWITCH — Figure 6

The ignition and starter switch has three positions: "off", "run" and "start". Start the engine by turning the key fully clockwise to start position and then release the key as soon as the engine starts. Stop the engine by turning the key counterclockwise to the "off" position.

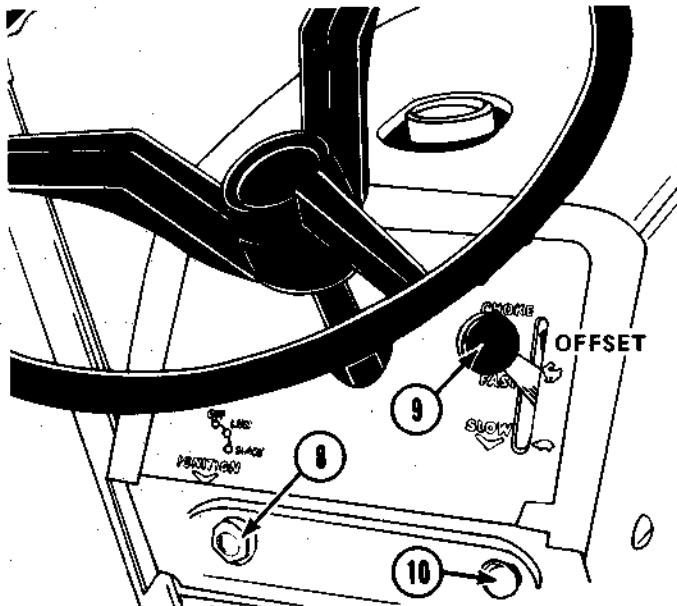

Figure 6

9 THROTTLE-CHOKE CONTROL LEVER — Figure 6

This control operates both the throttle and choke. When starting a cold engine, raise the lever past the offset and into the "choke" position. After the engine has started, lower the lever to the throttle operating range and allow the engine to warm at 1/2 throttle. Select the appropriate engine speed in the throttle range after the engine has warmed.

NOTE: Unless otherwise specified, the mower or snow thrower should be operated at full throttle. The throttle is not to be used to select desired travel speeds with the hydrostatic models. Operate at full throttle and regulate ground speed with the hydrostatic control lever.

10 LIGHT SWITCH (Optional) — Figure 6

If the optional kit is installed, turn lights on by pulling the control knob out. Turn lights off by pushing the knob in;

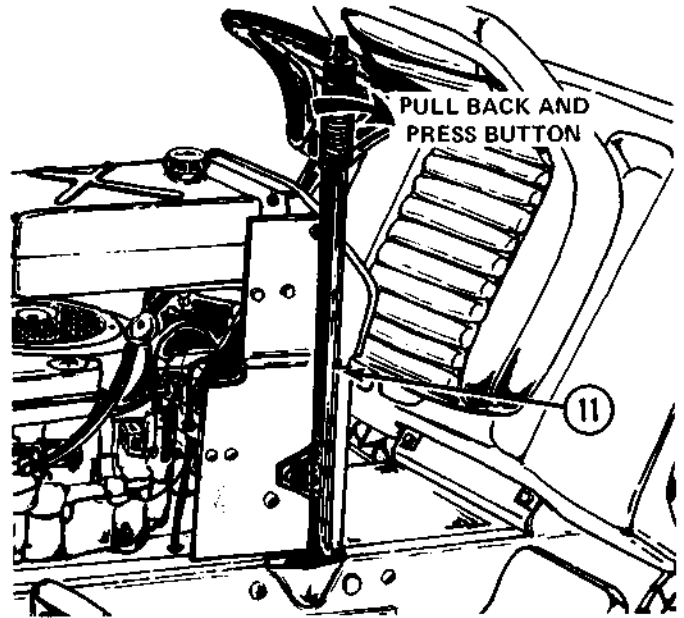

Figure 7

11 ATTACHMENT LIFT LEVER — Figure 7

The lift lever shown in figure 7 is used to raise and lower the mower, front blade or snow thrower.

To raise the attachment, pull the lever to the rear until the latch snaps into the notch provided. This will hold the attachment in the raised position.

To lower the attachment, pull the lever to the rear, depress the button to release the latch and allow the lever to move forward. See Figure 7.

RAISING THE HOOD — Figure 8

The engine, battery, electrical components, air cleaner, fuel filter and fuel tank are readily accessible by raising the hood. To raise the hood, grasp each side and raise it upwards and forward to its stop.

RAISING THE REAR DECK — Figure 8

The differential, transmission and control linkages are readily accessible by raising the rear deck until the seat rests against the steering wheel.

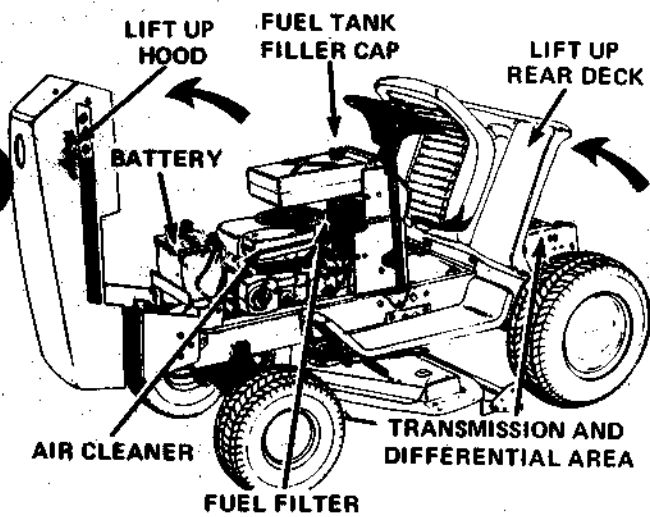

Figure 8

OPERATION

PRE-STARTING INSPECTION

Before starting the engine before each day's operation, the following checks and services should be performed:

1. Check oil in engine crankcase. Add oil as required to maintain proper level. See lubrication section.
2. Check fuel supply. Fill with clean, fresh regular gasoline only. See lubrication section.
3. Check air cleaner and service as required.
4. Check for engine, transmission or differential oil leaks. See your authorized Ariens dealers for repairs.
5. Make visual checks regarding safety precautions, obstructions and maintenance.

STARTING THE ENGINE

Use the following procedure to start the engine:

1. Lock the parking brake (6) by depressing the foot pedal, Figure 4, and pushing the brake lock forward to lock the parking brake.
2. **HYDROSTATIC MODELS.** Place hydrostatic control lever (2) in the "park-start" position as shown in Figure 2.

NOTE: The engine will not start unless the control lever is in the "park-start" position.

3. **GEAR SHIFT MODELS.** Place gear shift lever (3) in the forward (neutral) position as shown in Figure 3.

NOTE: The engine will not start unless the gear shift lever is in the "forward" neutral position.

4. Place implement power clutch lever (1) Figure 1, in the rear (disengaged) position.

NOTE: This is a safety feature. The engine will not start unless the clutch lever is in the disengaged position.

5. Raise throttle choke control lever (9), Figure 6, past the offset in the slot to the "choke" position.

6. Turn ignition key (8) shown in Figure 6 clockwise all the way. Release key as soon as the engine starts and gradually lower the throttle-choke control lever past the offset until the engine runs at 1/2 throttle.

NOTE: A WARM ENGINE WILL REQUIRE LESS CHOKING THAN A COLD ENGINE.

If the engine fails to start on the first attempt, turn key to the "off" position, wait a few minutes and try again. Do not operate starter continuously for more than 30 seconds at a time.

Always allow engine to warm up before applying load. In below freezing weather, allow engine to run at a fast idle for a period of at least five minutes before moving the tractor or starting the attachment. **SERIOUS DAMAGE TO THE ENGINE AND TRANSMISSION COULD RESULT IF THIS PROCEDURE IS NOT FOLLOWED.** 3400 - 3500 RPM

STOPPING THE ENGINE

Always use the following procedure to stop the engine:

1. **HYDROSTATIC DRIVE MODELS.** Move hydrostatic control lever to the "park-start" position.
2. **GEAR SHIFT MODELS.** Move gearshift lever to the "Neutral" position.
3. Disengage the implement power clutch.
4. Engage parking brake by depressing the foot pedal (5) and by moving brake lock (6) forward to "on" position.
5. Lower attachment to the ground.
6. Lower throttle lever and allow the engine to idle for a short period of time. **DO NOT STOP A HOT ENGINE AT HIGH SPEED AS INTERNAL ENGINE DAMAGE COULD RESULT.**
7. Turn ignition key counterclockwise to the "off" position to stop the engine.
8. **BE CAREFUL:** Remove ignition key before dismounting from tractor. This will prevent children and inexperienced operators from starting the tractor.

OPERATING THE HYDROSTATIC DRIVE TRACTOR

1. Start the engine using the procedure explained under "Pre-starting Inspection" and "Starting the Engine."

NOTE: The hydrostatic control lever must be in the "park-start" position and the implement power clutch lever must be disengaged to start the engine.

2. Release parking brake by depressing foot pedal until brake disengages.
3. Select the proper engine speed with the throttle-choke lever. When operating any power-driven attachment, run the engine at full throttle (3400 - 3500 RPM) unless otherwise specified. Use the hydrostatic control lever, **NOT THE THROTTLE**, to select a safe, appropriate travel speed.
4. To start the attachment, engage the implement power clutch with the engine running at 1/2 throttle. Then increase speed to full throttle.
5. To move the tractor forward and increase the

forward travel speed, gradually push the hydrostatic control lever forward from the neutral position as shown in Figure 9. To stop or slow down the tractor, pull the control lever back toward the neutral position.

NOTE: The numbers along the forward slot of the console cover do not indicate given speeds. They are provided as guidelines only.

To move the tractor backward and to increase the reverse travel speed, gradually move the hydrostatic control lever back into the reverse (R) slot from the neutral position. To stop the tractor or slow down the reverse travel speed, gradually move the control lever from the reverse (R) slot toward the neutral position.

IMPORTANT: NEVER OPERATE THE HYDROSTATIC CONTROL LEVER AND THE FOOT PEDAL SIMULTANEOUSLY AS THE LINKAGE COULD BECOME DAMAGED OR MISADJUSTED.

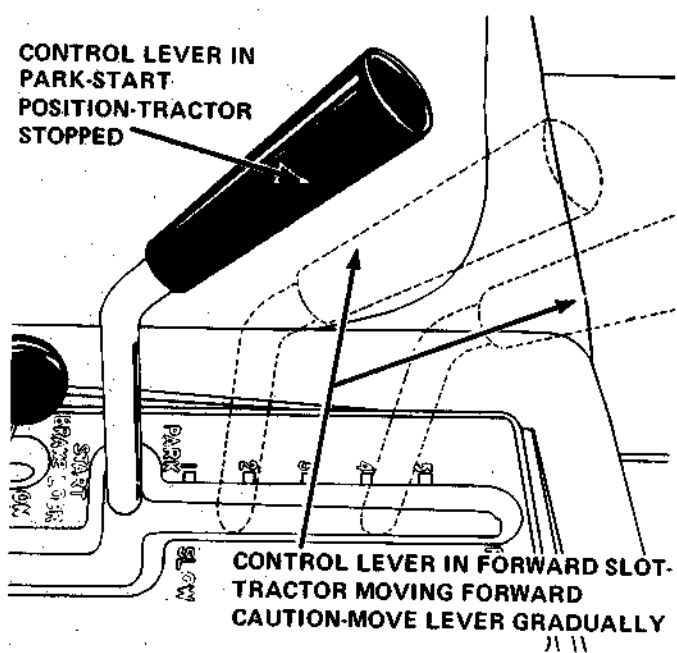

Figure 9



BE CAREFUL: ALWAYS REMOVE THE IGNITION KEY WHEN LEAVING THE TRACTOR TO PREVENT CHILDREN AND INEXPERIENCED OPERATORS FROM STARTING THE ENGINE.

OPERATING THE GEAR SHIFT TRACTOR

1. Start the engine using the procedure explained under "Pre-Starting Inspection" and "Starting the Engine."

NOTE: The gear shift lever must be in the forward neutral position and the implement clutch lever disengaged to start the engine.

2. Release brake lock by depressing the clutch-brake pedal, Figure 10, until the lock disengages.

3. Depress clutch-brake pedal approximately halfway (into the shifting range) as shown in Figure 10. Place gear shift lever into the desired gear and

slowly release the pedal to provide smooth acceleration.

IMPORTANT: DO NOT FORCE GEAR SHIFT LEVER IF GEAR DOES NOT ENGAGE. RETURN LEVER TO NEUTRAL, RELEASE PEDAL AND REPEAT THE PROCEDURE. THE CLUTCH-BRAKE PEDAL MUST BE IN THE SHIFTING RANGE TO ENGAGE ANY SELECTED GEAR. DEPRESSING THE PEDAL TOO FAR LOCKS THE TRANSMISSION MAKING IT IMPOSSIBLE TO SHIFT GEARS. DEPRESSING THE PEDAL TOO LITTLE WILL CAUSE GEAR CLASH AND POSSIBLE DAMAGE TO THE TRANSMISSION.

IMPORTANT: TRACTOR MUST BE COMPLETELY STOPPED WHEN SHIFTING GEARS. SERIOUS TRANSMISSION DAMAGE CAN RESULT IF GEARS ARE SHIFTED WITH TRACTOR IN MOTION.

4. Select the desired throttle speed with the throttle-choke control lever. When operating a power-driven attachment, operate the engine at full throttle (3400 - 3500 RPM) unless otherwise specified and control travel speed by selecting an appropriate gear.

5. To start the mower or snow thrower, engage the implement power clutch slowly with the engine running at 1/2 throttle, then increase speed to full throttle.

6. To stop the tractor, depress foot pedal to the braking range, then return it to the shifting range and place gear shift lever in neutral. Fully depress pedal and engage the brake lock when parking or leaving the tractor. (Figure 10)

EMERGENCY STOPPING

Always use caution when mowing — be alert for children, pets or obstacles in path. If necessary to make emergency stop, step firmly on brake pedal. (On hydrostatic model tractor, drive control lever automatically returns to neutral when brake pedal is depressed.)

IMPORTANT: ALWAYS REMOVE IGNITION KEY WHEN LEAVING THE TRACTOR TO PREVENT CHILDREN AND INEXPERIENCED OPERATORS FROM STARTING THE ENGINE.

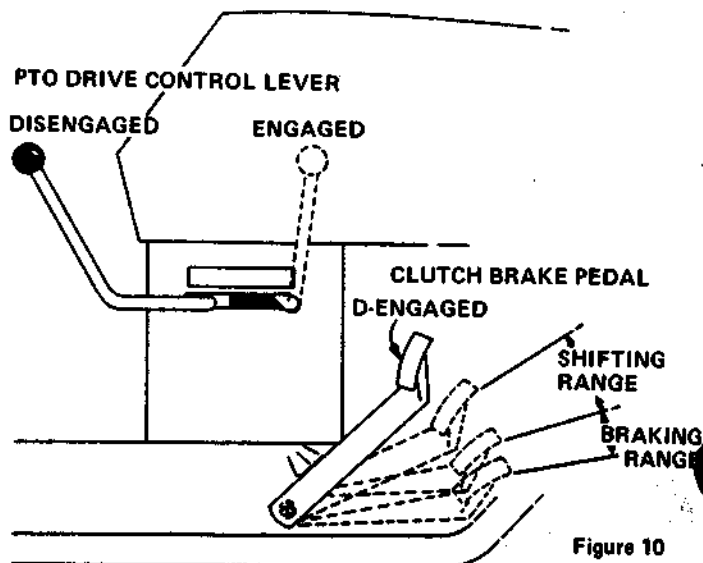

Figure 10

BE CAREFUL

1. BEFORE SERVICING ANY ATTACHMENT:

**DISENGAGE POWER.
SHUT OFF ENGINE.
MAKE SURE BLADES OR AUGER HAS STOPPED REVOLVING.
DISCONNECT ENGINE SPARK PLUG CABLE.**

2. KEEP CHILDREN, BYSTANDERS AND PETS OUT OF THE WORKING AREA.

3. KEEP HANDS, FEET AND CLOTHING AWAY FROM POWER DRIVEN PARTS.

4. KEEP ALL SHIELDS AND GUARDS IN PLACE.

LUBRICATION

Proper lubrication according to a regular schedule is a vital part of maintaining the Model S-8 Garden Tractor. The following lubrication schedule should be followed closely.

Use clean, fresh "regular" grade of automotive gasoline. Do not use premium gasoline. Do not mix oil with gasoline.

FILLING THE TANK — Figure 11

The fuel tank filler cap is easily accessible as shown in Figure 11. Before filling the tank, wipe all dust and dirt from around the cap to prevent dirt from falling into the tank. Use an approved gasoline container and keep it clean. Fill the tank completely. The tank capacity is 1-3/8 gallons.

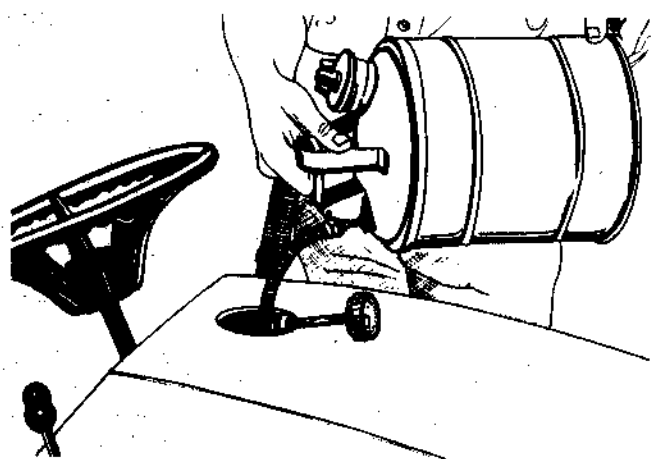

Figure 11

ALWAYS USE CAUTION WHEN HANDLING GASOLINE. NEVER FILL THE FUEL TANK WHEN THE ENGINE IS RUNNING OR WHEN THE ENGINE IS HOT. NEVER SMOKE WHILE FILLING THE TANK. REMOVE THE IGNITION KEY BEFORE FILLING TANK.

ENGINE OIL LEVEL

Check the engine crankcase oil level daily or every five hours of operation. The oil level should be maintained to the "Full" mark on the dipstick, Figure 12. Never allow the oil level to fall below the "Add" mark or serious damage could result. **DO NOT OVERFILL.** Oil level must never exceed the "full" mark. Oil capacity is 2 1/4 U.S. pints.

To check the oil, place the tractor on a level surface, stop the engine and wipe all dirt and dust from around the dipstick, Figure 12. Pull dipstick out, wipe off the oil and reinsert by pushing it down tightly (until it snaps into place). Pull dipstick out and observe the oil level. Add sufficient oil of the proper viscosity (see chart) to bring the level up to the "Full" mark.

SERVICE	OIL TYPE
Lawn and Garden Attachments	Ariens SAE 10W-30 MS or equivalent
Snow Removal Equipment	Ariens SAE 5W-20 MS or equivalent

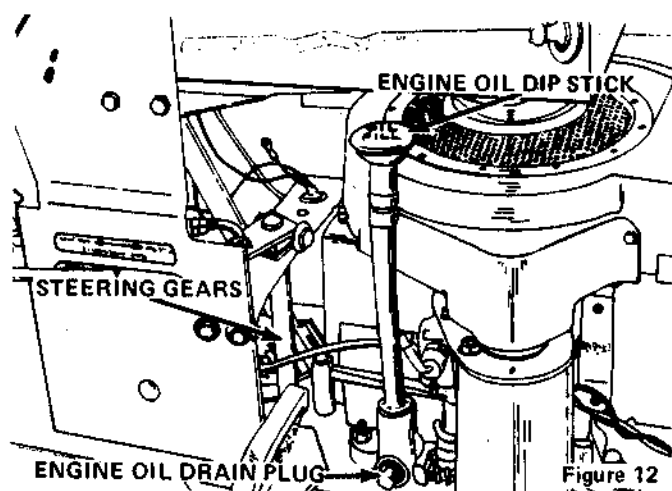

IMPORTANT: ENGINE WILL SMOKE EXCESSIVELY IF DIPSTICK IS NOT PUSHED DOWN UNTIL IT SNAPS INTO PLACE.

CHANGE ENGINE CRANKCASE OIL

When the tractor is new, the oil should be changed after the first five hours of operation. Thereafter under normal operating conditions the oil should be changed every 25 hours of operation. If extremely dusty or dirty conditions prevail, change oil more frequently.

Drain crankcase by removing the oil drain plug, Figure 12, while the engine is warm. Allow the oil to run into a container.

NOTE: With the engine warm, the oil will flow more freely permitting more contaminants to be drained from the crankcase.

Replace drain plug. Remove dipstick and refill crankcase with 2 1/4 U.S. pints of the proper type and viscosity of oil as shown in the chart. Check oil on the dipstick to determine that the level is to the "Full" mark. **DO NOT OVERFILL.**

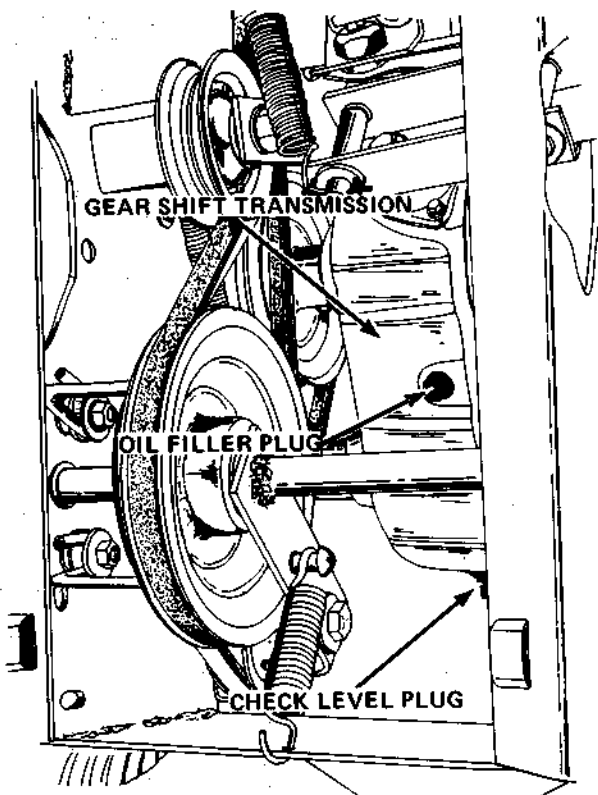

Figure 13

level is correct when the lubricant reaches the filler plug hole. Add Ariens Premium Gear Lube SAE 90 MP until the proper level is reached.

TRANSMISSION OIL LEVEL (Hydrostatic Models)

The hydrostatic transmission oil level should be checked monthly or every 25 hours of operation.

To check the oil level, raise the rear deck and clean all dirt and dust from the oil expansion reservoir area, Figure 15. Remove cap from the reservoir and observe the oil level. The level is correct when the reservoir is $\frac{1}{2}$ full at ambient temperature.

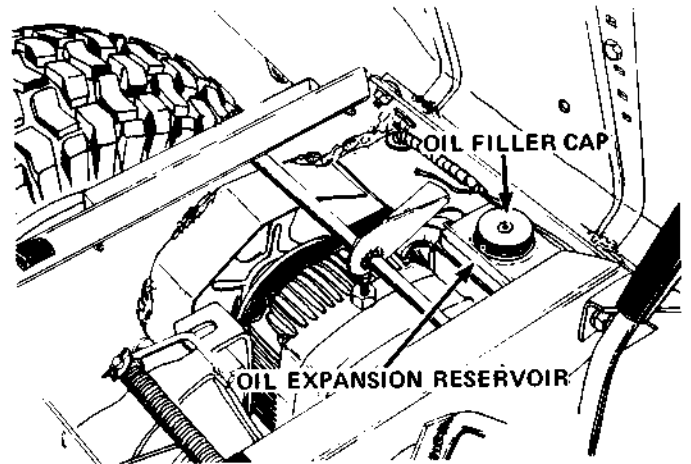

Figure 15

TRANSMISSION OIL LEVEL (Gear Shift Models)

The transmission oil level should be checked monthly or every 25 hours of operation.

To check the oil level, place tractor on a level surface, raise the rear deck and remove the "check plug" from the rear of the transmission as shown in Figure 13. The level is correct when oil seeps out of the check plug hole. If the level is below the check plug hole, remove the filler plug from the top of the transmission and add Ariens Premium Gear Lube SAE 90 MP until the proper level is reached.

DIFFERENTIAL OIL LEVEL (Hydrostatic Models)

The differential oil level should be checked monthly or every 25 hours of operation.

To check the oil level, place the tractor on a level surface, raise the rear deck and remove the "filler plug" at the rear of the differential, Figure 14. The

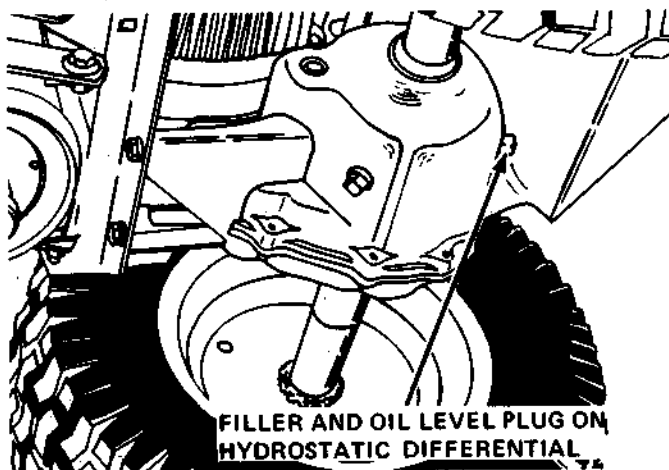

Figure 14

If the reservoir is less than $\frac{1}{2}$ full at ambient temperature, add TYPE "A" transmission FLUID until proper level is obtained.

IMPORTANT: ALWAYS USE NEW, CLEAN, TYPE "A" TRANSMISSION OIL AND BE EXTREMELY CAREFUL NOT TO ALLOW ANY FOREIGN MATTER TO CONTAMINATE THE OIL AS SERIOUS TRANSMISSION DAMAGE COULD RESULT.

DO NOT OVERFILL the reservoir as the oil expands during operation and may leak out around the cap.

IMPORTANT: PROPER OIL LEVEL IS ESSENTIAL FOR FULL BRAKING EFFECT AND PROTECTION AGAINST SEVERE TRANSMISSION DAMAGE.

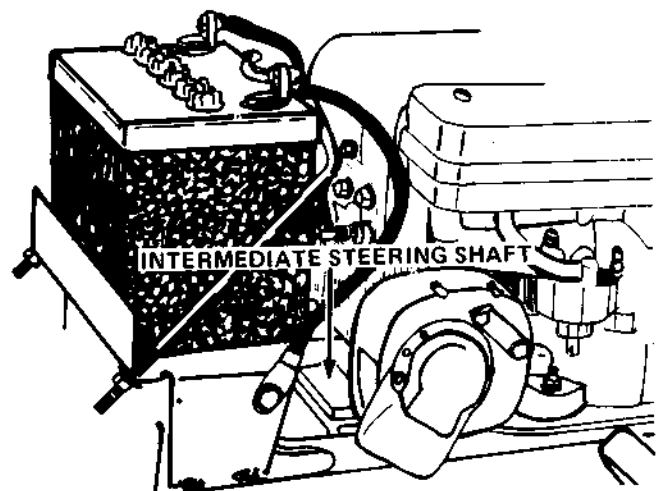

Figure 16

STEERING GEARS

Apply a light coat of Ariens Moly Lithium grease to the steering gears every 50 hours of operation. See Figure 12.

INTERMEDIATE STEERING SHAFT

Apply oil to the bearing surfaces of the blocks every 50 hours of operation. See figure 16.

GREASE FITTINGS

Following is a list of the grease fittings with reference numbers that identify each location on the corresponding pictures. Figures 17 & 18. Each fitting should be wiped clean before and after lubrication. Grease each fitting every 50 hours of operation with Ariens Moly Lithium grease.

1. Figure 17 — Right and left king pin.
2. Figure 17 — Right and left front wheel.
3. Figure 18 — Hydrostatic control arm pivot (hydrostatic models).

POINTS TO OIL

Periodically oil the lift point pivots, front axle pivot, control linkage pivots and the floating intermediate shaft pivots to insure long life and smooth

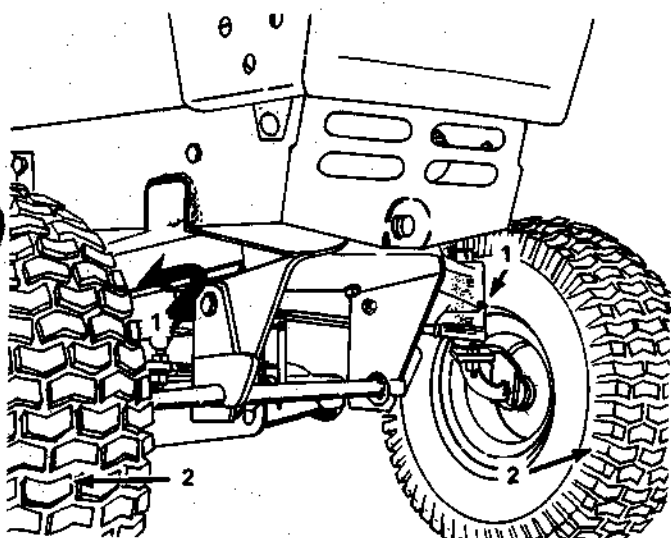

Figure 17

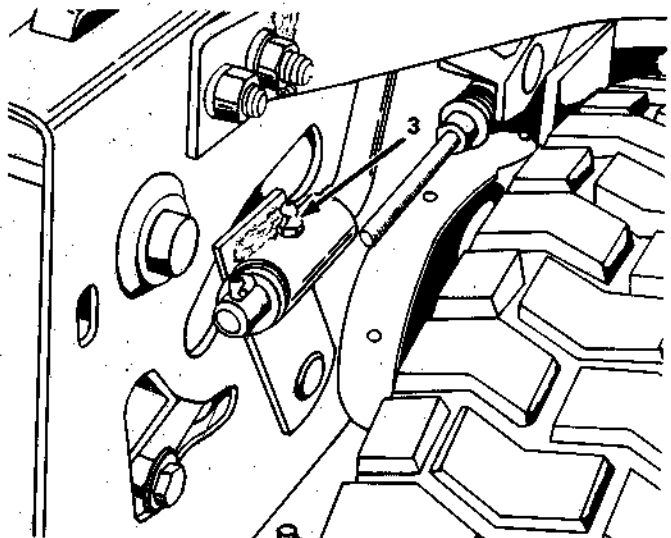

Figure 18

operation of the parts.

There is no lubrication required on the mower.

IMPORTANT: KEEP GREASE AND OIL OFF THE BELTS TO PREVENT BELT SLIPPAGE AND DETERIORATION.

MAINTENANCE

GENERAL

Ariens dealers will provide any service which may be required to keep the Lawn Tractor operating at peak efficiency. Ariens Company recommends that you contact an Ariens dealer before making any adjustments to this tractor. Refer to the engine instruction manual and engine nameplate for engine maintenance instructions. If repairs or service are required for the engine, see your Ariens dealer or the nearest authorized engine service station.

AIR CLEANER SERVICE

Clean the air cleaner and re-oil the element every 25 hours under normal operating conditions. When operating in extremely dusty conditions, perform this service at more frequent intervals. Use the following procedure to service the air cleaner:

1. Raise the tractor hood. Remove screws A, Figure 19, and lift off complete air cleaner assembly.
2. Remove screen and spacers from the foam element, Figure 19.
3. Wash foam element in kerosene or liquid detergent and water to remove dirt. Wrap foam in cloth and squeeze dry. Let dry overnight.
4. Saturate foam element in clean engine. Squeeze to remove the oil.
5. Re-assemble parts and re-install complete assembly on the carburetor.

NOTE: When re-assembling the parts, make certain the foam element extends over the edge of the air cleaner body. The foam element will form a protective seal.

IMPORTANT: NEVER RUN THE ENGINE WITH THE AIR CLEANER REMOVED!

ENGINE COOLING SYSTEM

The engine is air cooled. Grass particles, chaff and dirt may clog the cooling system, especially when mowing dry grass or operating in extremely dusty conditions. Continued operation with a clogged cooling system may cause severe overheating and possible engine damage.

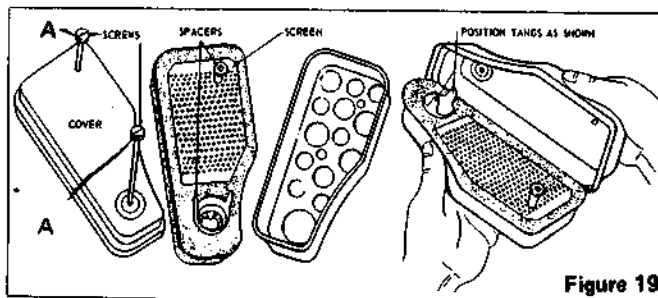
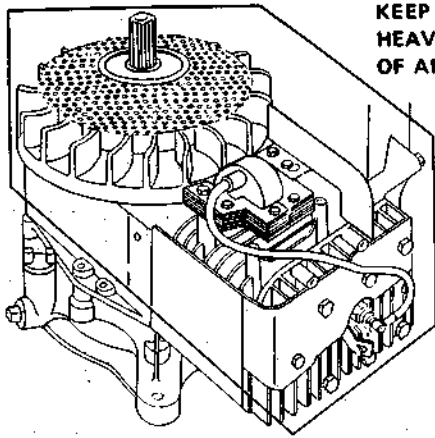

Figure 19

It is essential that the rotating screen, engine cooling fins and the exhaust system be kept free of dirt and debris which could cause the engine to overheat.

To avoid overheating and possible engine damage, periodically remove the shrouding from around the cooling fins, Figure 20, and clean the area shown within the heavy black line of all grass, dirt or chaff accumulation.



KEEP AREAS WITHIN
HEAVY LINES CLEAR
OF ALL DEBRIS

FIGURE 20

TRANSMISSION COOLING SYSTEM

Dirt and grime accumulations on transmission cooling fins can cause overheating. Check and clean the cooling fins every 50 hours of operation or quarterly. In extremely dusty or dirty conditions, clean the cooling fins more frequently.

CAUTION: KEEP WATER AWAY AND OFF RESERVOIR.

Check the hydrostatic cooling fan blades periodically to assure that the blades are not bent or broken and that the fan is in good condition.

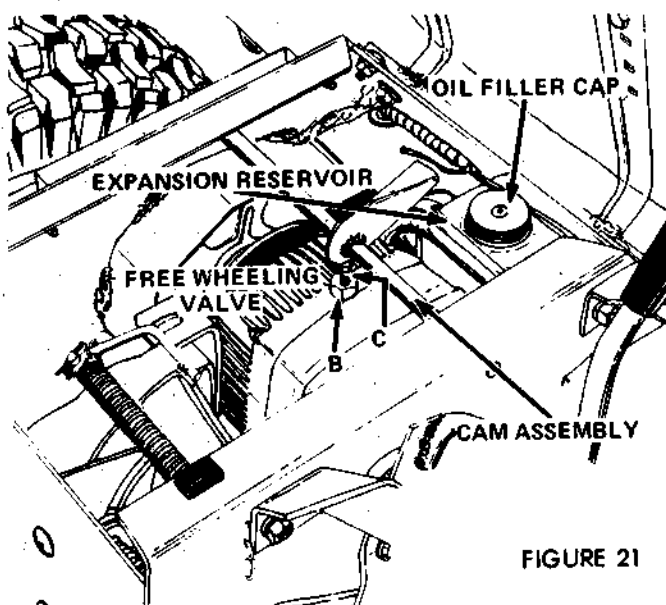

FIGURE 21

BLEEDING THE TRANSMISSION

If for any reason the oil level is ever permitted to fall below the expansion reservoir, air may enter the system causing the transmission to malfunction. If this should occur, use the following procedure to "bleed" (remove air from the transmission):

1. Thoroughly clean all dust, dirt and grime from the free-wheeling valve, the oil filler cap and surrounding areas, Figure 21.

2. Remove nut A, Figure 22 from the left end of the cam assembly shaft and slide the cam assembly to the right until the cam arm is free of the valve actuating rod.

3. Loosen nut B first and then valve actuating rod C, Figure 21, and remove the rod. Be extremely careful not to allow dirt to enter the transmission.

4. Remove the expansion reservoir filler cap and add "Type A" transmission fluid until the reservoir is 1/2 full.

5. Jack up rear of the tractor, start the engine and operate at a slow idle speed.

6. With engine running, move speed control lever to both forward and reverse positions until oil appears at the free-wheeling valve hole.

7. Replace free-wheeling valve actuating rod C and tighten nut B, Figure 21, to 30 inch-pounds. Tighten both parts carefully to prevent the small rubber o-rings inside the cap from becoming damaged.

8. Replace cam assembly, Figure 22. Tighten nuts A so the cam arm intersects the center of the valve actuating rod and the shaft has 1/32" end play.

9. Recheck the oil level. If necessary add oil until the reservoir is half full.

NOTE: THE CAM ARM MUST BE IN THE FORWARD POSITION BEFORE THE TRACTOR CAN BE OPERATED.

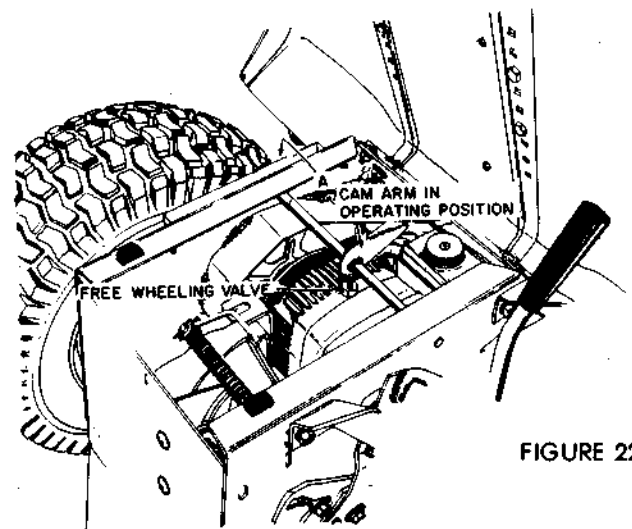

FIGURE 22

5-8 HYDROSTATIC TRANSMISSION — LOSS OF OUTPUT TORQUE

Loss of output torque is caused by one of the following reasons.

1. Heat. The operating temperature of the transmission fluid has exceeded 180° F.
- A. Cooling fan on backwards. Cupped side of fin to be toward transmission. See Figure 1.
- B. Dirt and grass in cooling fins. Do not clean transmission with pressure water or steam (unless a shield or cover is placed over the reservoir cover during wash operation, or in other situations where water may be introduced into the system). This will cause moisture in the system. Refer to paragraph 2.
- C. Low oil level. Oil level in expansion reservoir must be ½ full. Use type "A" transmission fluid.
- D. Air lock. Air can be locked inside the transmission causing a low oil level situation. To bleed air out, remove the free wheeling valve on top of transmission pour type "A" transmission fluid into expansion reservoir until fluid runs out free wheeling valve hole. Replace free wheeling valve. Start unit and operate transmission for approximately 2 minutes to attempt to free any air that may still be locked inside. Stop unit and allow to set for at least 5 minutes. Remove free wheeling valve to allow the remainder of the air to escape and replace. Fill expansion reservoir to ½ full with type "A" transmission fluid.

2. Water in transmission fluid. Milky appearance. Remove the expansion reservoir and the transmission from the tractor. Remove hex plug, adaptor filter, and free wheeling valve. **NOTE: Adaptor filter has left hand threads.** Flush complete system with a fast drying solvent. Reassemble the transmission and all related parts in the tractor. Fill the transmission with type "A" transmission fluid eliminating air lock as described in paragraph 1-D above.

3. Free wheeling valve. Valve should be fully extended. Length beyond nut is approximately ¾ inch.

4. Internal leakage due to wear. This condition is unusual; however, when it occurs, replace the transmission.

5-8 HYDROSTATIC TRANSMISSION — SERVICE PARTS

1. We have made available the input shaft and related parts, and also the control shaft seal in addition to other items previously available. **SEE ILLUSTRATION BELOW.**

BATTERY SERVICE

Check the battery electrolyte level once each week or every 25 hours of operation. Check it monthly if the tractor is idle or is in storage. Add distilled water to bring the level to the bottom of the split ring in the filler tube of each cell.

Each spring and fall clean the battery and terminals with ammonia or bicarbonate of soda solution

5-8 LAWN TRACTOR

HYDROSTATIC DRIVE

HYDRAULIC DRIVE- EATON MODEL 8
SERVICED AND WARRANTED BY ARIENS CO.
ON AN EXCHANGE BASIS.
ARIENS PART NO. 829010

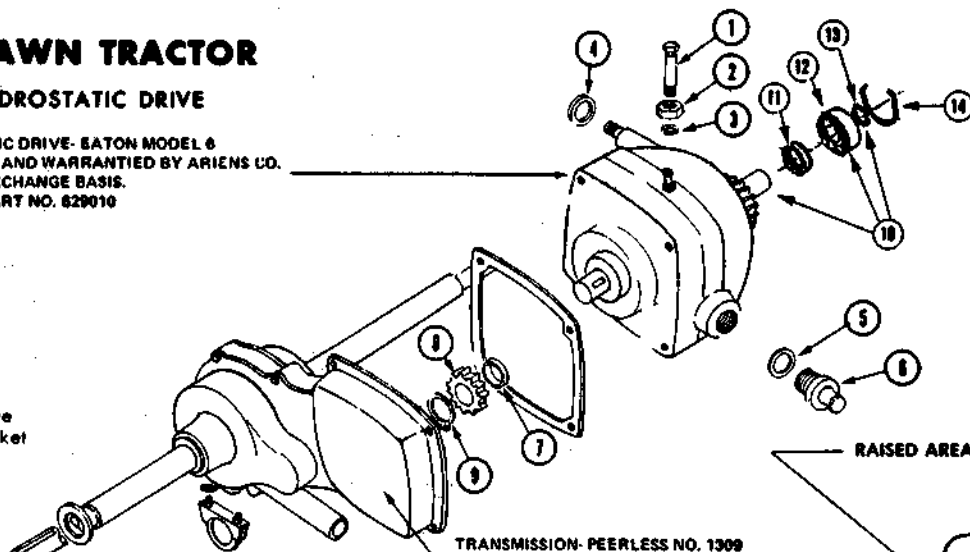

- | | | |
|----|--------|--|
| 1 | 29217 | Dump Valve |
| 2 | 29215 | Nut w Gasket |
| 3 | 56078 | "O" Ring |
| 4 | 56079 | Oil Seal |
| 5 | 29216 | Gasket |
| 6 | 29214 | Adaptor |
| 7 | 29143 | Spacer |
| 8 | 29046 | Gear |
| 9 | 57061 | Snap Ring |
| 10 | 529014 | Input Shaft
w/bearing and snap ring |
| 11 | 56095 | Seal |
| 12 | 54071 | Bearing |
| 13 | 57072 | Snap Ring |
| 14 | 57071 | Snap Ring |

TRANSMISSION- PEERLESS NO. 1309
SERVICED AND WARRANTED BY
TECUMSEH PRODUCTS

RAISED AREA FACES HYDRO

5-8 HYDRO COOLING

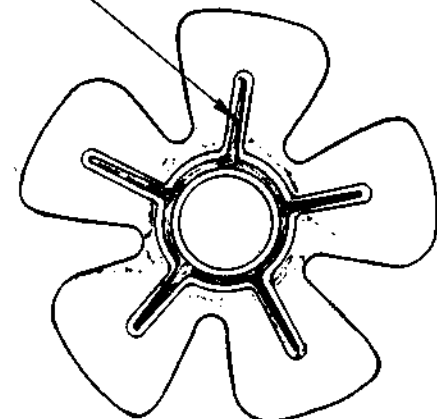

NOTE: For additional information on 5-8 hydrostatic transmission see Service Letter L-124.

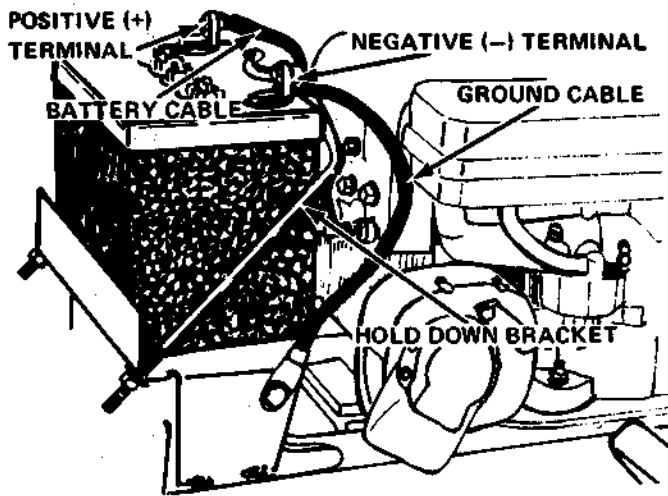

FIGURE 23

When installing the battery, make certain the ground cable is connected to the negative (-) terminal on the battery, see Figure 23. Be sure the battery cable is connected to the positive (+) terminal.

IMPORTANT: REVERSED BATTERY CABLES OR REVERSED CABLES FROM A BATTERY CHARGER OR BOOSTER BATTERY CAN BLOW THE 7½ AMP FUSE SHOWN IN FIGURE 24. ALWAYS DISCONNECT THE TERMINAL AT THE FUSE WHEN CHARGING THE BATTERY OR WHEN ELECTRIC WELDING IS DONE ON THE TRACTOR.

FUEL FILTER SERVICE

When dirt or other foreign material is allowed to enter the fuel tank it will collect in the fuel filter eventually causing fuel stoppage. If this occurs, disassemble and clean the filter, Figure 25.

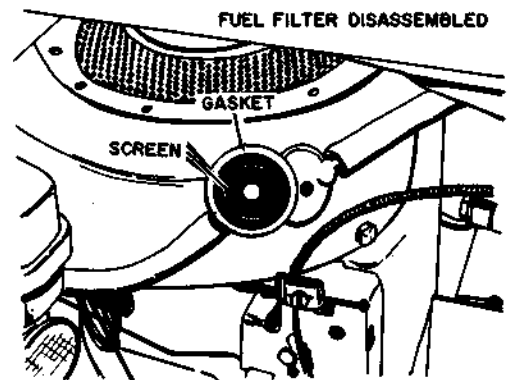

FIGURE 25

followed by flushing with clean water. Keeping the battery clean will prolong battery life. After cleaning, apply a light coat of grease to the terminal and cable ends.

Keep cable clamps securely tightened to terminals and keep battery hold-down clamps tight to prevent vibration but do not overtighten as this could warp the case.

WARNING: STORAGE BATTERIES GIVE OFF HIGHLY INFLAMMABLE HYDROGEN GAS. DO NOT ALLOW SPARKS OR FLAME NEAR BATTERY. DO NOT LAY TOOLS ACROSS BATTERY TERMINALS WHICH MAY CAUSE A SPARK RESULTING IN AN EXPLOSION.

Maintain the battery at full charge during storage and during the winter months to prevent freezing. When water is added during freezing weather, run the engine at least one hour to bring the battery up to a full state of charge.

NOTE: Figures 26 and 27 show the right rear tractor tire removed for clarity and for easier access to the brake adjustment.

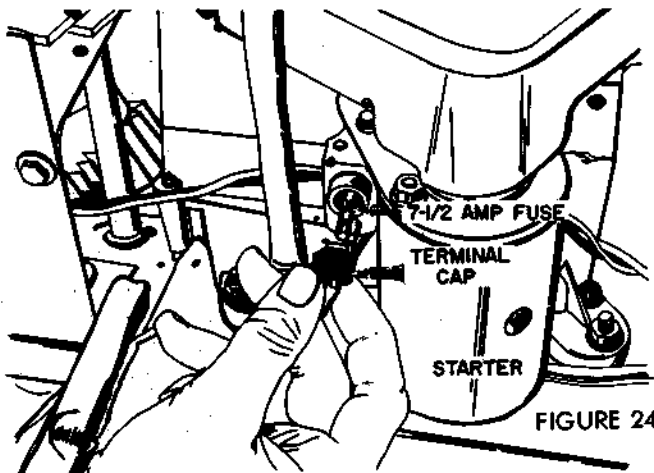

FIGURE 24

TIRE PRESSURES

Check tire pressures at least once each month. Inflate tires to pressures shown in the chart. Use a low pressure tire gauge for accurate readings.

Keep tires properly inflated at all times. Overinflation will cause operator discomfort. Underinflation will cause short tire life. Always see that the tire valve caps are in place and securely tightened to prevent air loss.

DESCRIPTION	LAWN WORK	SNOW THROWER AND FRONT BLADE WORK
Front tires (15 X 6.00-6)	10	12
Rear tires (20 x 8.00-10)	6	6

SERVICE & ADJUSTMENTS

BRAKE ADJUSTMENT

If the brake does not hold or stop the tractor, or if it is extremely difficult to engage the brake lock, it is necessary to adjust the brake. Use the following procedure.

1. Depress clutch brake pedal and engage the brake lock to hold brake in the engaged position.
2. Tighten nuts A, Figure 26, until the compres-

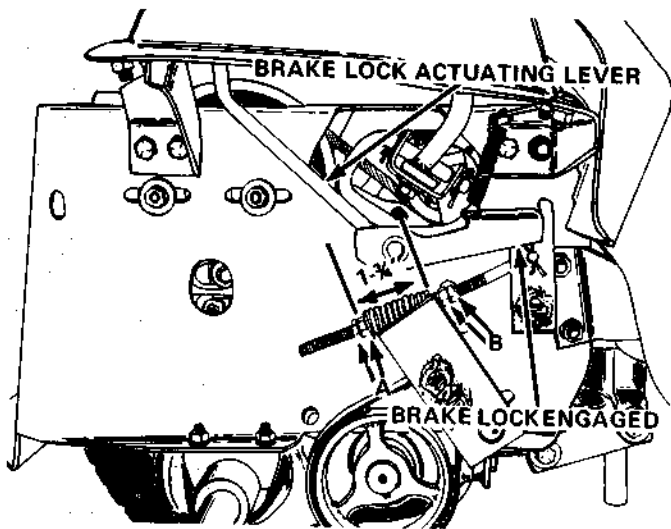

Figure 26

sion spring measures 1 3/4 inch.

NOTE: Nuts B must not touch the support when making the adjustment. Allow at least 1/16" clearance between nuts B and the support when adjusting the spring length.

3. Release brake lock and allow the brake pedal to return to its normal position against the stop.

4. Tighten nuts B, Figure 27, until compression spring measures as follows:

- Hydrostatic models — 2-1/8"
- Gear shift models — 1-15/16"

NOTE: The clutch free-travel may be affected after adjusting the brake. Adjust if necessary as outlined under "Clutch Free Travel Adjustment."

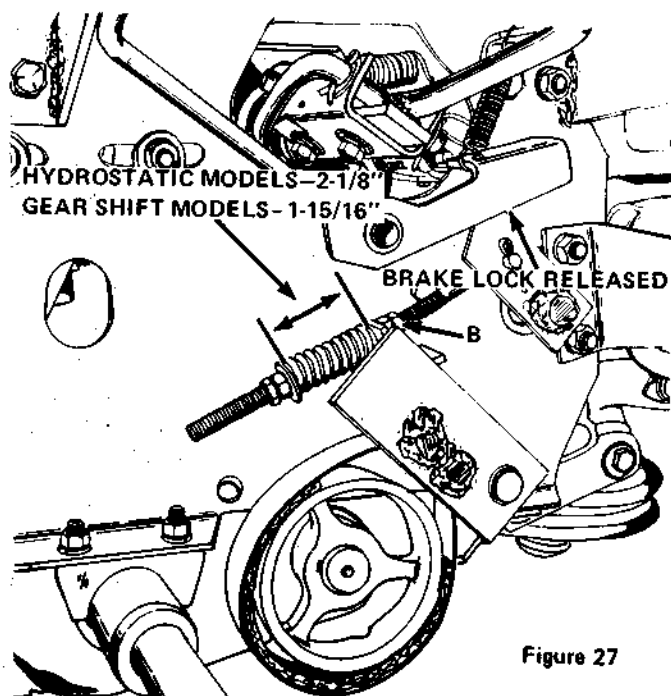

Figure 27

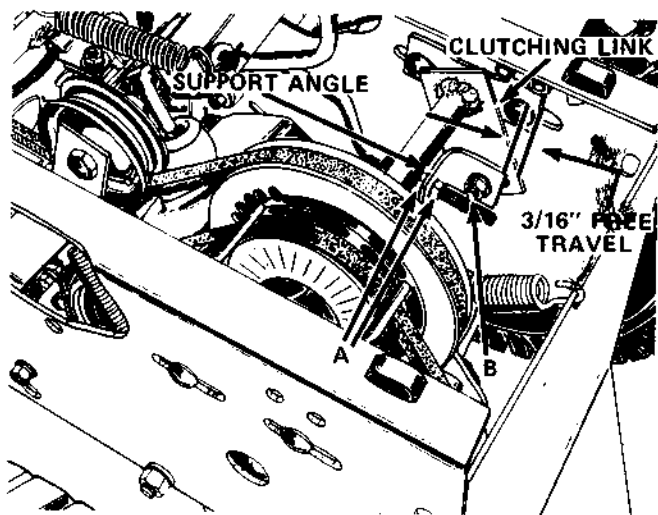

Figure 28

CLUTCH FREE TRAVEL ADJUSTMENT (Gear Shift Models)

The clutch rod must be adjusted to insure that the transmission drive belt is fully engaged when the clutch brake pedal is released.

To adjust the free travel, move nuts A, Figure 28, front or back so that when depressing the clutch brake pedal the support angle moves forward 3/16" before bolt B contacts the front of the slot in the clutching link.

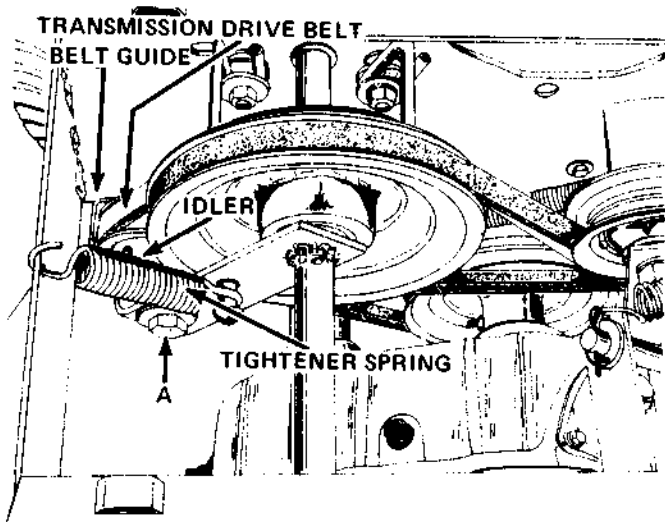

Figure 29

TRANSMISSION DRIVE BELT (Gear Shift Models)

The transmission drive belt idler should be adjusted if the drive belt slips or if the spring coils have bottomed out. See Figure 29. Adjust by loosening bolt A and moving the idler back in the slotted hole of the mounting bracket until the belt does not slip and until there is clearance between the spring coils. Before tightening bolt A, place the belt guide 1/8" from the belt in such a position that it does not bind the belt in any position of the idler.

Check belt guide D, Figure 30. It should be positioned 1/8" from the belt at the point where the belt enters the drive sheave. Adjust by loosening the

mounting bolt A and positioning the guide as required.

NOTE: The clutch free-travel may be affected after adjusting the drive belt idler. Adjust if necessary as outlined under "Clutch Free Travel Adjustment."

INTERMEDIATE SHAFT DRIVE BELT (Gear Shift Models)

The intermediate shaft drive belt should be tightened if it begins to slip or before the idler bracket contacts the stop bolt as shown in Figure 30.

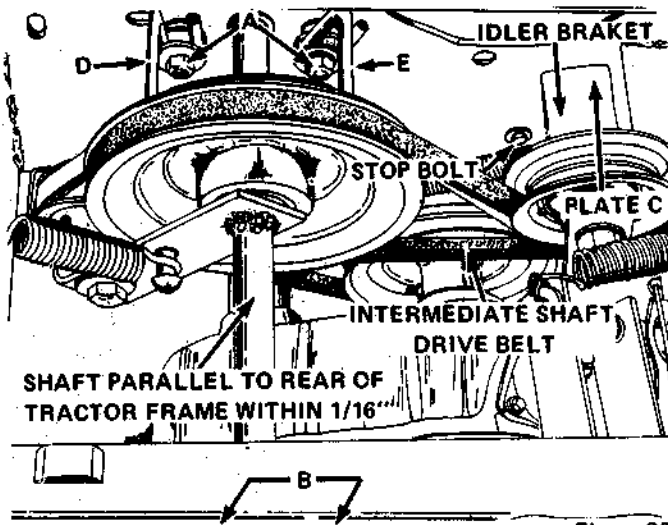

Figure 30

To adjust the belt tension, loosen the four intermediate shaft mounting bolts A and B, Figure 30, and move the shaft rearward keeping it parallel to the rear of the tractor frame until the front edge of the idler bracket is flush with the plate identified at C.

NOTE: THE SHAFT MUST BE PARALLEL TO THE TRACTOR FRAME WITHIN 1/16 INCH.

Adjust belt guides D and E 1/8" from the belt at the points where the belt is tangent to the sheave and tighten the shaft mounting bolts A and B.

NOTE: The clutch free-travel adjustment can be affected after tightening this belt. Re-adjust as previously outlined if necessary.

PTO DRIVE BELT (Implement Power)

The PTO drive belt should be adjusted before the rear nuts B, Figure 31, contact the pivot block when the implement power clutch is engaged or if the belt begins to slip.

Use the following procedure to adjust the belt:

1. Engage implement power clutch and tighten nuts C, Figure 31, until the spring length is 2-5/8".

NOTE: When making this adjustment, there must be clearance between the rear nuts B and the pivot block. Move nuts B rearward if necessary to obtain this clearance before measuring the spring length.

PTO DRIVE OVERCENTER ASSEMBLY

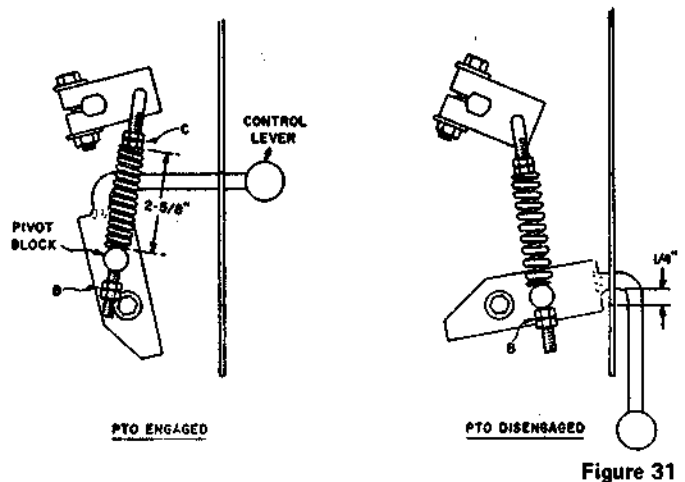

Figure 31

2. Position belt guides D and E, Figure 32, across from one another when the clutch is disengaged in such a manner that the belt is retained in the disengaged position. In addition, guide D must clear the engine sheave by 1/8" as the clutch is moved from the disengaged to the engaged position. Move guide D rearward if necessary to obtain this clearance.

3. With clutch disengaged, tighten nuts B, Figure 31, to obtain 1/4" clearance between the implement power clutch lever and rear of slot in the tractor frame.

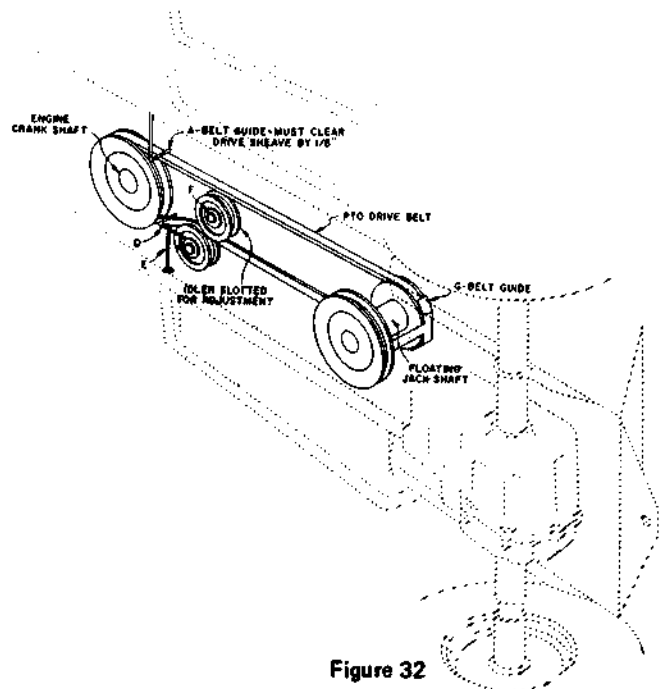

Figure 32

If after adjustment, the rear nuts B, Figure 31, contact the pivot block when the clutch is engaged, loosen bolt F, Figure 32, and move the idler closer to the belt to provide additional adjustment. Repeat the complete adjustment sequence if it becomes necessary to move the idler.

HYDROSTATIC TRANSMISSION DRIVE BELT (HYDROSTATIC MODEL ONLY)

The hydrostatic drive belt does not require tightening. Belt tension is achieved by a spring-loaded idler. Replace the belt if it has stretched or worn to the point where it begins to slip.

HYDROSTATIC NEUTRALIZER PEDAL ADJUSTMENT (HYDROSTATIC MODEL ONLY)

The linkage should be adjusted to automatically return the hydrostatic control lever to the "park-start" (neutral) position when the neutralizer pedal is depressed.

To adjust the neutralizer pedal, place control lever in the "park-start" position, loosen bolt A, Figure 33, depress the foot pedal and apply the brake lock, then retighten bolt A.

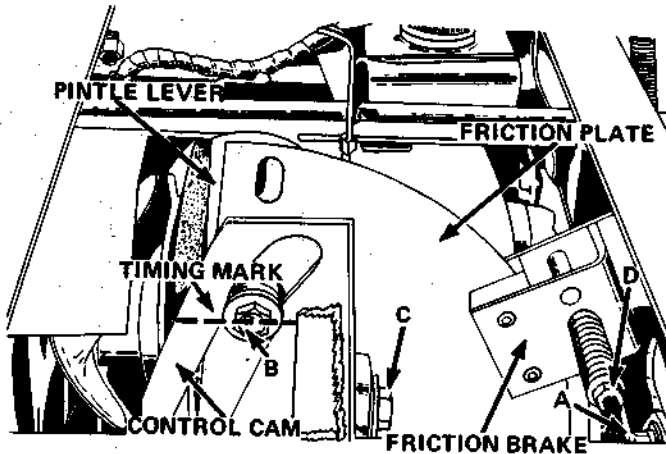

Figure 33

Release brake lock, move the control lever to a forward position then depress the foot pedal. The control lever should return to "park-start" (neutral). Repeat process by placing control lever in reverse. When the adjustment is properly made, the control lever will automatically return to neutral from either forward or reverse when the neutralizer pedal is depressed.

IMPORTANT: NEVER DEPRESS BRAKE PEDAL AND MOVE THE HYDROSTATIC CONTROL SIMULTANEOUSLY. THE LINKAGE IS INTERCONNECTED AND DAMAGE OR MIS-ADJUSTED LINKAGE COULD RESULT.

HYDROSTATIC NEUTRAL ADJUSTMENT (HYDROSTATIC MODEL ONLY)

The hydrostatic controls should be adjusted so the rear tires stop rotating when the control lever is returned to neutral either manually or with the neutralizer pedal.

Use the following procedure to adjust neutral:

1. Check HYDROSTATIC NEUTRALIZER PEDAL ADJUSTMENT. If required, adjust as previously explained.
2. Check position of the timing mark on control cam. With the shift lever in the "park-start" position and brake lock engaged, the center line of bolt head B, Figure 33, should be aligned with the timing mark

on the cam. If the timing mark does not align with the bolt head, loosen bolt C and move the cam up or down as required to align the bolt head with the timing mark. Tighten nut C securely after making the adjustment.

3. Jack up rear of the tractor until rear tires are clear of the ground.

4. Start engine and increase speed to full throttle.

5. Loosen bolt B slightly. Insert a screwdriver through the slots in the friction plate and the pintle lever, Figure 33. Pivot the pintle lever left or right until the rear tires stop rotating and retighten bolt B.



WARNING: KEEP HANDS AND ANY LOOSE CLOTHING AWAY FROM THE HYDROSTATIC COOLING FAN AND DRIVE BELT WHEN MAKING ADJUSTMENT. THESE PARTS MUST ROTATE WHEN MAKING THE NEUTRAL ADJUSTMENT.

HYDROSTATIC CONTROL LEVER BRAKE ADJUSTMENT

The hydrostatic control lever friction brake must be adjusted so the control lever moves through the "forward" and "reverse" modes with a minimum of force. However, due to the neutral tendency of a hydrostatic transmission to neutralize, the brake must be tightened sufficiently so the tractor maintains any selected speed setting.

To adjust the friction brake, tighten or loosen bolt D, Figure 33, until the proper braking is reached.

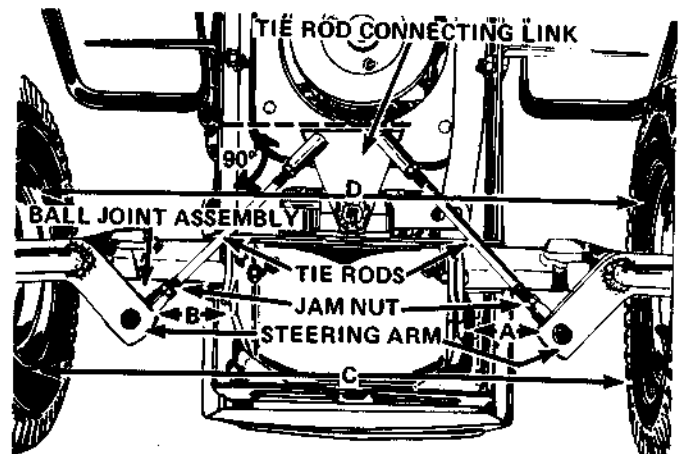

Figure 34

FRONT WHEEL TOE-IN ADJUSTMENT

Proper toe-in of the front wheels is necessary to assure proper steering and to reduce tire wear. Correct toe-in is when the front of the wheels are 1/8" to 1/16" closer together than the rear of the wheels (measured at the horizontal center line of the rim flanges).

If the steering develops a wandering characteristic or if excessive tire wear develops, the toe-in of the front wheels should be checked. If the toe-in is not correct, adjust as follows:

1. Turn steering wheel until the rear edge of the tie rod connecting link is perpendicular (90 degrees) to the tractor frame as shown in Figure 34.
2. Adjust length of tie rods until distances A and

B are equal and so distance C is between 1/8" to 1/16" less than distance D.

NOTE: Use following procedure to shorten or lengthen tie rods:

1. Loosen jam nuts on both ends of tie rods, Figure 34.
2. Rotate tie rods until distances A and B, Figure 34, are equal and distance C is 1/8" to 1/16" less than D.
3. Tighten jam nuts securely.

SEAT ADJUSTMENT

The seat is adjustable front or back to any one of six different positions. Adjustment is made by removing the four mounting bolts located under the seat, moving the seat to the most comfortable position and then replacing the mounting bolts in the appropriate holes.

BELT REPLACEMENT

If it becomes necessary to replace one of the tractor drive belts, the following diagrams show the proper placement of the belts and belt guides. After installing a belt it will be necessary to follow the adjustment procedures outlined in the ADJUSTMENT section of this manual.

PTO DRIVE BELT — Figure 32

1. Adjust guide A to clear the engine drive sheave by 1/8 inch.
2. Adjust guide G to clear the floating jackshaft sheave by 1/8 inch.
3. Position idler F to provide least amount of belt tension when installing a new belt.
4. Adjust belt tension and guides D and E using the procedure outlined in "Maintenance and Adjustment" section.

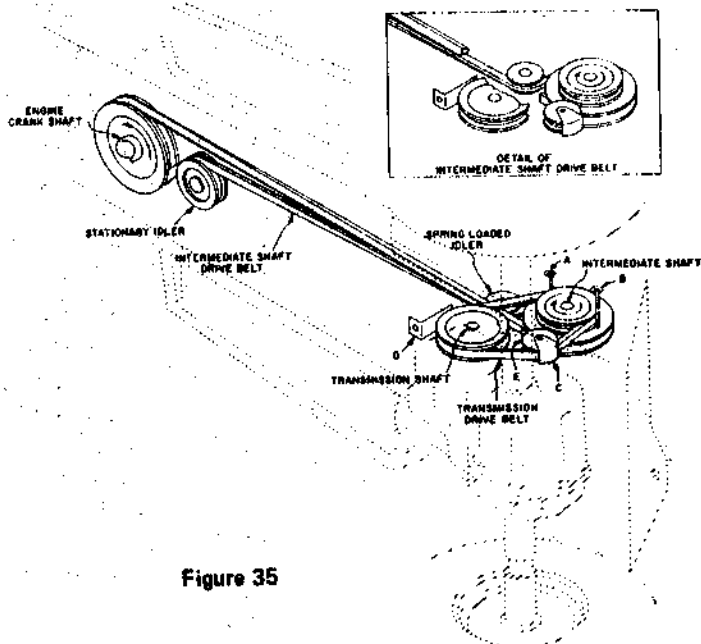

Figure 35

MECHANICAL TRANSMISSION DRIVE BELTS — Figure 35

Intermediate Shaft Drive Belt

Follow the instructions outlined in the ADJUSTMENT section.

Transmission Drive Belt — Figure 35

1. Position guides A and B 1/8" from drive sheave at the points where belt is tangent to the sheave.
2. Position guide D, 1/8" from the transmission sheave.
3. Idler E is mounted in a slotted hole. Position to provide lease amount of belt tension when installing a new belt.
4. Place guide C 1/8" from the belt in such a position that it does not bind the belt in any position of the idler.
5. Adjust belt tension using the procedure outlined in ADJUSTMENT section.

HYDROSTATIC TRANSMISSION DRIVE BELT — Figure 36

No adjustments are necessary when replacing the hydrostatic transmission drive belt. Belt tension is maintained by the spring-loaded idler.

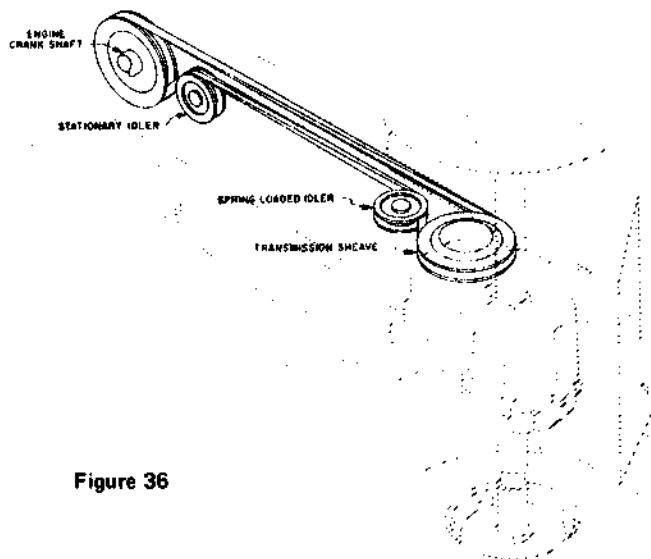

Figure 36

36 RM ROTARY MOWER

The Model 36 RM Rotary Mower is standard equipment on both the S-8 Gear Shift and Hydrostatic tractors.

ATTACHING THE MOWER TO THE TRACTOR

Use the following procedure to attach the mower to the tractor:

1. Remove ignition key. Place implement power clutch lever in the "disengaged" position and "engage" the tractor brake lock.
2. Raise the tractor attachment lift lever. Figure 7.
3. Place cutting height adjustment lever in the

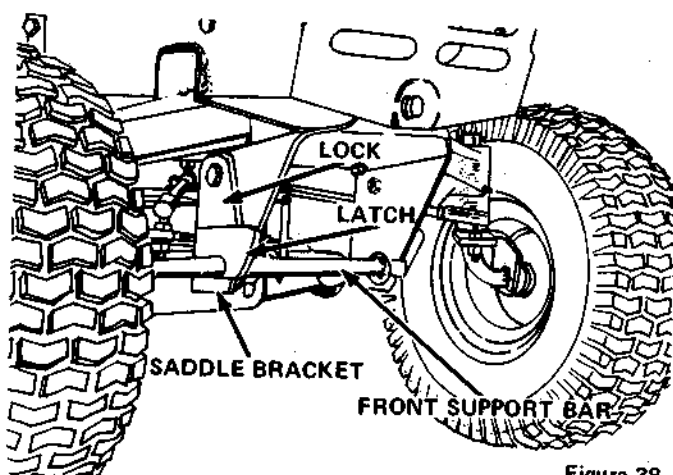

Figure 38

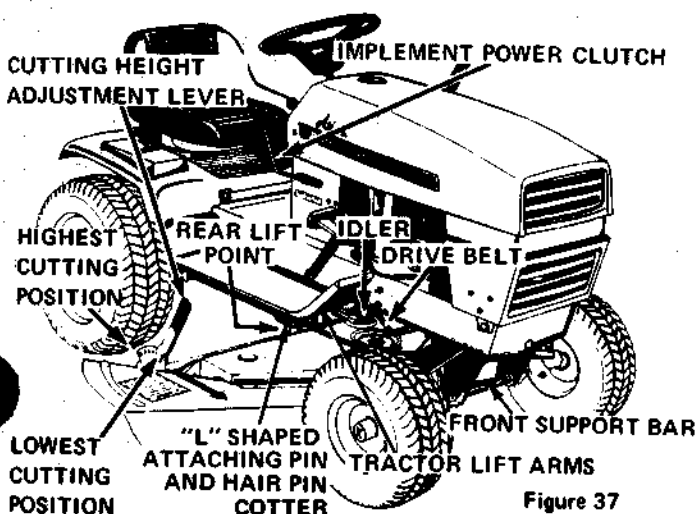

Figure 37

REMOVING MOWER FROM THE TRACTOR

Reverse the attaching procedure to remove the mower from the tractor.

BEFORE OPERATING THE TRACTOR

Before operating your rotary mower, carefully read this manual. Become thoroughly familiar with the controls, safety precautions and proper operating procedures. The more familiar you become with the tractor and mower the better results you will have.

Use the following procedure to operate the mower:

1. Move cutting height adjustment lever, Figure 37, to one of the six positions available to obtain the desired height of cut.
2. Raise the mower by pulling the attachment lift lever rearward until the lock snaps in place.
3. Start the engine as outlined in the TRACTOR OPERATION section.
4. Drive tractor to the work area before starting the mower.
5. Slowly engage the implement power clutch with the engine running at $\frac{1}{2}$ throttle. Increase engine speed to full throttle after the blades are rotating.



CAUTION: KEEP BYSTANDERS AWAY FROM THE AREA WHILE THE BLADES ARE ROTATING.

second lowest cutting position, see Figure 37.

4. Raise front support bar to clear the front tractor tire and slide the mower under the tractor from the right side.

5. Place the drive belt over the rear lift point and lower the attachment lift lever. Align ball joint of rear lift point to tractor lift arms and secure with the "L" shape attaching pin and hairpin cotter provided, Figure 37.

6. Position drive belt over the drive and driven sheaves and place idler to the inside of the belt as shown in Figure 37.

7. Position front support bar in the tractor saddle brackets and secure with the locks and latches, see Figure 38.

6. The mower blade speed is directly related to the engine speed. For best mowing results, OPERATE

ENGINE SPEED AT FULL THROTTLE. Regulate travel speed on hydrostatic models with the hydrostatic control lever. Regulate travel speed on gear shift models by selecting an appropriate gear. The power requirement increases in dense, high grass conditions. If travel speed of the tractor is too fast for mowing conditions, the engine and thus the mower will slow down reducing the cutting efficiency of the mower. In some conditions, excessive FORWARD travel speeds may cause the engine to stall and the mower to plug or a drive belt to slip.

7. For any emergency or "panic" stops, depress the clutch brake pedal on gear shift models or the neutralizer and brake pedal on the hydrostatic models.

NOTE: KEEP FOOT OFF PEDAL DURING NORMAL OPERATION. NEVER USE PEDAL AND HYDROSTATIC CONTROL LEVER SIMULTANEOUSLY AS THE PARTS ARE INTER-CONNECTED AND THE LINKAGE COULD BECOME DAMAGED OR MISADJUSTED. ON GEAR SHIFT MODELS, BELT SLIPPAGE COULD OCCUR.

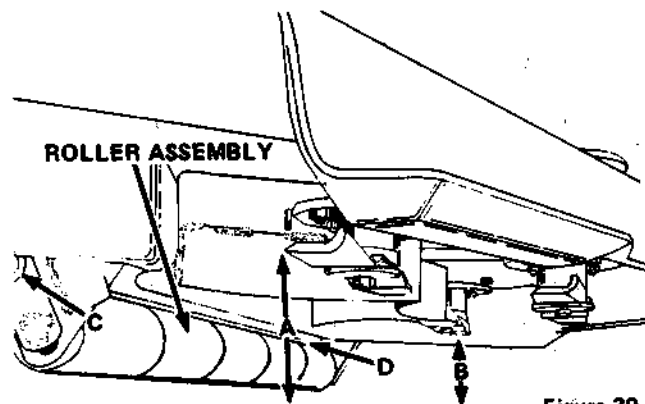

Figure 39

NOTE: If there are any indications of damage to the mower deck, blades or blade spindles, measure the blade tips at A and B, then rotate the blades 180 degrees and measure the opposite blade tip ends. If the measurements vary more than 1/8" on any blade, see your Ariens dealer for service. If the variation is not excessive, level the mower using the lowest measurement from blade tip to ground at A and B.

MOWER ADJUSTMENTS AND MAINTENANCE



BE CAREFUL: NEVER ATTEMPT TO SERVICE OR MAKE ANY ADJUSTMENTS TO THE MOWER WHILE THE ENGINE IS RUNNING. WHEN SERVICING OR MAKING ADJUSTMENTS; IT IS A GOOD PRACTICE TO USE THE FOLLOWING PROCEDURE:

1. Disengage implement power clutch.
2. Hydrostatic models — Place hydrostatic control lever in the "park-start" position and apply brake lock.

Gear shift models — Place gear shift lever in first gear and apply brake lock.

3. Lower the mower.
4. Stop engine and remove ignition key.
6. Disconnect spark plug wire.

ADJUSTING BLADE LEVEL AND PITCH

Proper leveling of the blades is essential in obtaining a smooth, evenly cut lawn. Blade pitch is correct when the front blade tips are slightly lower than the rear blade tips. Improper pitch adjustment will affect engine power requirements and can cause uneven cutting.

Use the following procedure to adjust blade level and pitch:

1. Check tire pressure and adjust as required (front tires — 10 lbs.; rear tires — 6 lbs.)
2. Place tractor on a smooth level surface, preferably a concrete slab or smooth floor.
3. Place cutting height adjustment lever, Figure 37, in the highest cutting position.
4. With the attachment lift lever, lower the mower so the roller assembly firmly rests on the floor.
5. Rotate the blades until they are parallel to the roller assembly as shown in Figure 39. Measure distances A and B (from end of blade tips to the floor). These distances should be equal. If they are not equal, loosen roller assembly adjusting bolt C or D and pivot the mower deck up or down until distances A and B are equal with the roller resting firmly on the floor.

6. Tighten roller assembly mounting bolts securely.

7. Rotate the blades until they are perpendicular to the roller assembly as shown in Figure 40.

8. Measure distances A (from both outboard tips to the floor). Then measure distance B. The front blade tip (distance B) should be 1/8" less than the rear blade tip (distance A). Loosen both front support mounting bolts C and pivot front of mower "up" or "down" until the front blade tip B is 1/8" closer to the floor than the rear blade tips A.

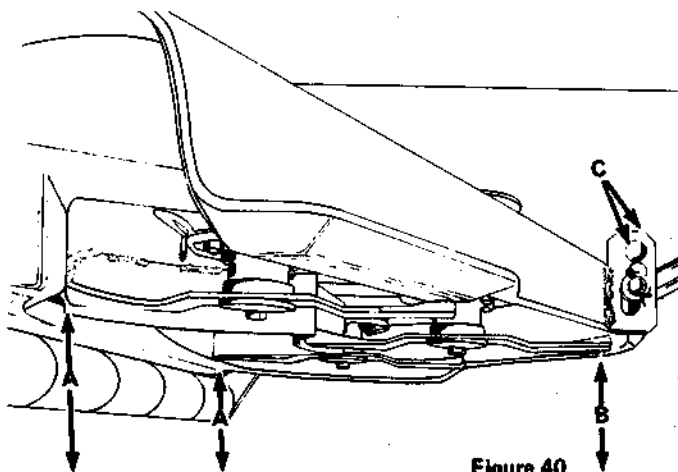

Figure 40

CUTTING HEIGHT

The cutting height is adjustable to any of six different positions by moving the cutting height adjustment lever shown in Figure 37. Raise the lever to decrease cutting height. Lower the lever to increase cutting height.

MOWER DRIVE BELT REPLACEMENT

Constant tension is maintained on the drive belt by a spring-loaded idler. Therefore, belt adjustment is not required.

Figure 41 shows the correct belt rotating (with

shield removed) in case it ever becomes necessary to replace a worn or damaged belt.

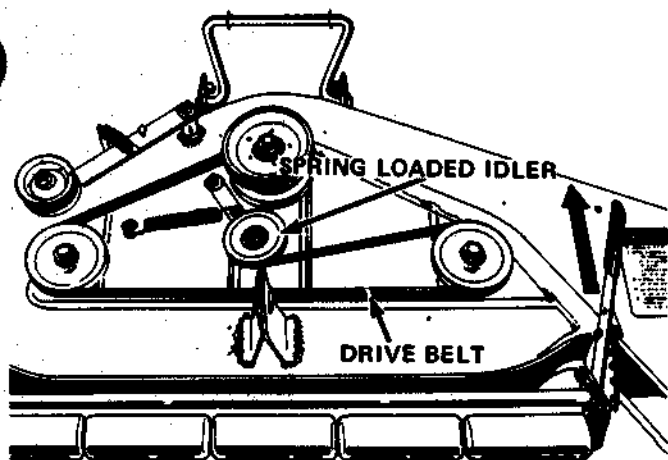

FIGURE 41

MOWER BLADE CARE

Blades should be kept sharp and tightly mounted at all times. They can be sharpened on the mower with a file or removed and sharpened on a grinding wheel.

IMPORTANT: ALWAYS FOLLOW THE ORIGINAL CUTTING EDGE BEVEL WHEN SHARPENING THE

BLADES AND SHARPEN BOTH ENDS EVENLY TO MAINTAIN PROPER BALANCE!

Special "cupped" washers help protect the mower by allowing the blade to slip on the spindles if a solid object is struck.

NOTE: WHEN REPLACING A BLADE, ALWAYS INSTALL THE SPECIAL "CUPPED" WASHER WITH THE CONCAVE SIDE FACING THE BLADE AND TIGHTEN THE BLADE MOUNTING BOLTS TO 50-60 FT-LBS TORQUE.

STORING THE MOWER

The following maintenance is recommended at the end of each mowing season.

1. Remove mower from the tractor using the procedure outlined in this manual.
2. Remove all buildup of material under the deck.
3. Remove rust from any exposed metal and cover the areas with paint or a light coat of oil.
4. Store the mower in a dry place.

OPTIONAL EQUIPMENT — MULCHING KIT

An optional mulching kit is available for the 36 RM Rotary Mower. This kit can be used when grass or leaves are to be finely chopped and discharged into the stubble under mower deck rather than through the discharge opening.

IMPROVEMENT PACKAGES

S-8 DRIVE IMPROVEMENT PACKAGES

Designed to improve 72102 and 72103 Drive Belt failures on 929001 Serial No. 101 - 1382 and 929002 Serial No. 101 - 1946 tractors. Improvements available upon request.

No. 529012 Improvement Package for S-8 Gear, Model 929001. This package consists of a new spring anchor for increased tension on the belt to reduce belt slap. An idler stop is also included to keep idler from reaching frame.

No. 529013 Improvement Package for S-8 Hydro, Model 929002. This package consists of a new idler arm and our standard 12132 Idler. New arm improves idler alignment and increased belt tension.

Check For:

1. Unbalanced or bent engine sheave which will contribute to belt failure.
2. Wire harness clips out of position interfering with belt.
3. Any projections or rough areas in belt path, such as weld splatter.

The installation instructions for the improvement packages are as follows.

Ariens

Improvement Package Kit No. 529012 for S-8 Gear Tractor

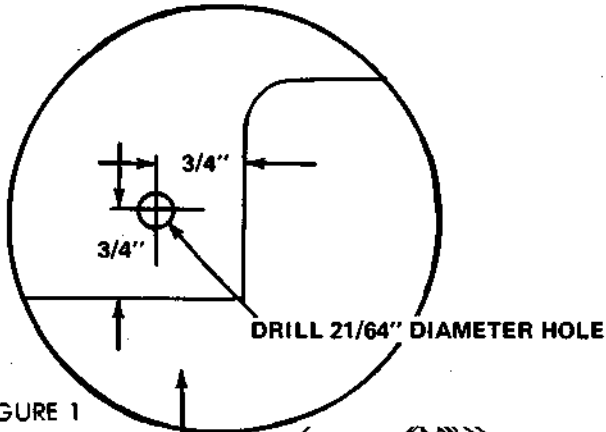

FIGURE 1

LOCATE AND DRILL HOLE AS SHOWN
INSERT ITEMS
1, 2, 3 and 4.

INSERT TAB THRU
EXISTING HOLE.

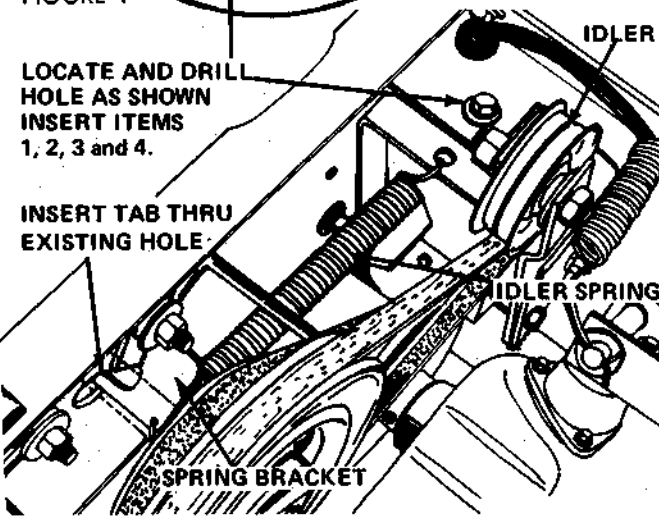

FIGURE 2

REF. NO.	PART NO.	DESCRIPTION	NO. REQ'D
1	059069	CAP SCREW, 5/16 - 18 x 1 - 1/4	1
2	085042	LOCKNUT, 5/16"	1
3	075026	GROMMET	2
4	064007	WASHER, 1/4"	1
5	029263	SPRING BRACKET	1

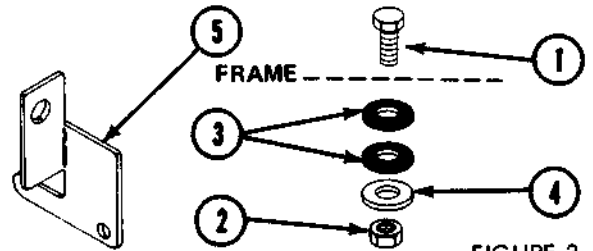

FIGURE 3

5. The idler stop consists of a cap screw, two grommets, a washer and a hex nut. Assemble in the hole as shown in Figure 3 with the cap screw on top of the frame and both grommets under frame.

GENERAL

The up-grade kit No. 529012 is designed to improve the action of the belt idler in all S8 Gear Drive tractors. It consists of an improved spring anchor and an idler stop.

INSTALLATION

1. Tip up the seat for access to the idler and spring. Remove the idler spring from its anchor and remove the anchor which consists of a cap screw (59144), a lockwasher (63006) and two locknuts (65021).

2. The new spring anchor is installed on one of the belt finger bolts, with a tab projecting through a hole in the side frame. See Figure 2. Remove the nut, lockwasher and flat washer from the belt finger; Discard the flat washer; install the spring anchor as shown in Figure 2; and replace the lockwasher and nut.

3. Hook up the idler spring to the new anchor.

4. To install the idler stop, a hole must be drilled in the frame next to the idler. Locate the hole as shown in Figure 1. Drill a 21/64 diameter hole.

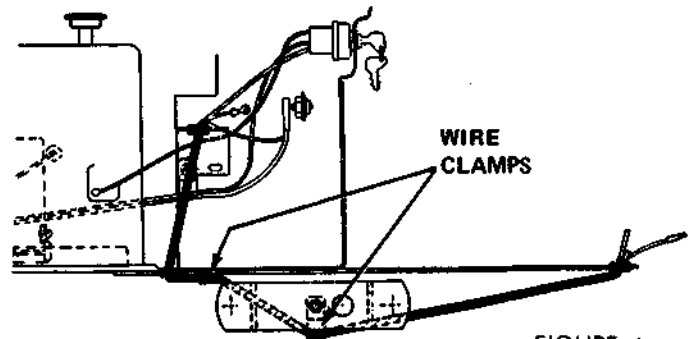

FIGURE 4

6. After assembly is completed, check and adjust the belt as described in the Owner's Manual.

7. Check along the belts to be sure there is no interference between belts and wire clamps on the wiring harness. Orient the wire clamps as shown in Figure 4 for proper clearance.

8. Check the engine sheave (29105). If runout or wobble seems to be a problem, replace the sheave.

Ariens

Improvement Package Kit No. 529013 for S-8 Hydrostatic Tractor

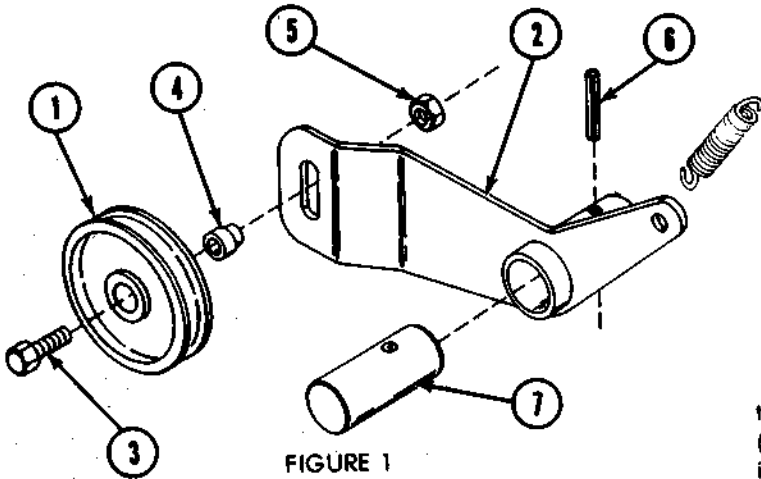

FIGURE 1

REF. NO.	PART NO.	DESCRIPTION	NO. REQ.
1	012132	IDLER	1
2	029265	IDLER ARM	1
3	059148	CAPSCREW, H.H. 5/16" - 18 x 1 1/2	1
4	010360	SPACER	1
5	065042	LOCKNUT, 5/16" - 18	1
6	058016	ROLL PIN, 3/16" x 1"	1
7	029264	PIVOT PIN	1

GENERAL

The up-grade kit No. 529013 is designed to replace the idler in all S8 Hydrostatic Drive tractors. This will result in improved idler performance and eliminate the problems associated with the old idler design. The new idler is supplied assembled and will directly replace the old assembly.

INSTALLATION

1. Remove the mower pan to gain access to the idler.
2. Remove the idler spring. Pull the cotter pin (67006) and remove the idler assembly. This assembly consists of the parts shown on Figure 2. None of these parts are re-used.

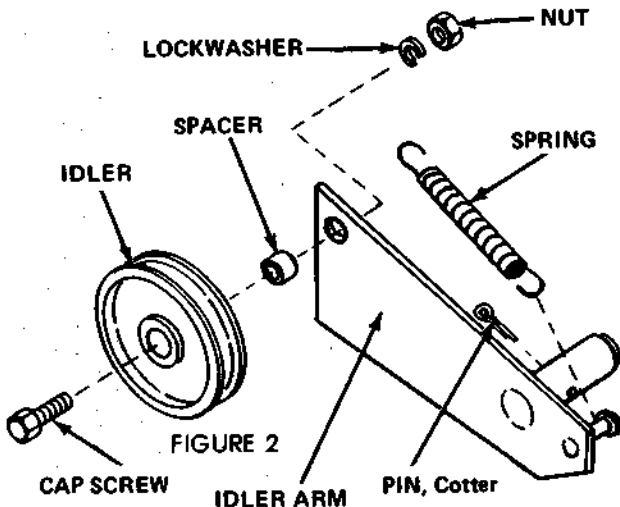

FIGURE 2

3. Position the new idler assembly (Figure 1) in the same position as the old. Insert the pivot pin (29264) and secure the idler assembly in place by inserting the roll pin (58016) through the idler arm hub and pivot pin.

4. Replace the idler spring between the old spring anchor and the hole in the new idler assembly. Check the action of the idler assembly. Put a drop of oil on the pivot points.

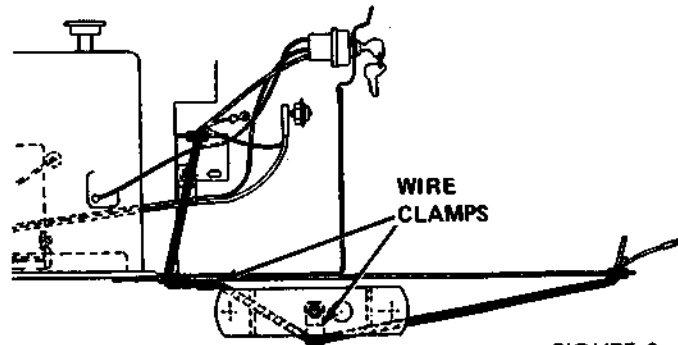

FIGURE 3

5. Check the belt alignment. Belt should run in the center of the idler.

6. Check along the belts to be sure there is no interference between belts and wire clamps on the wiring harness. Orient the wire clamps as shown in Figure 3 for proper clearance.

7. Check the engine sheave (29105). If runout or wobble seems to be a problem, replace the sheave.

TROUBLE SHOOTING

MODEL	TYPE OF FAILURE	CAUSE	SOLUTION
1)	Engine will not crank.	Hydrostatic control lever not in "park-start" position.	Move lever to "park-start" position.
		Gear shift lever not in forward neutral position.	Move lever to the forward neutral position.
		Implement power clutch engaged (forward position).	Disengage implement power clutch.
		Battery connections dirty. Dead battery. Defective safety switch.	Clean battery connections. Recharge or replace battery. Replace switch.
		Mal-adjusted safety switch on gear drive tractor.	Adjust switch.
		Loose electrical connections.	Tighten all connections firmly.
2)	Engine difficult to start.	Out of fuel.	Refuel.
		Fuel tank shut-off valve closed.	Open valve.
		Dirt or water in fuel system.	Clean and flush entire fuel system.
		Carburetor out of adjustment.	Adjust carburetor.
		Worn, pitted, ignition breaker points.	
		Mal-adjusted breaker points.	
		Faulty spark plug.	Re-gap or replace spark plug.
		Carburetor out of adjustment.	Adjust carburetor.
		Dirt or water in fuel system.	Clean and flush entire fuel system.
		Cold engine.	Choke engine until warmed up.
		Governor not operating properly.	
Faulty engine valves.			
Air cleaner plugged.	Service air cleaner.		
3)	Engine will not idle.	Carburetor out of adjustment.	Adjust carburetor.
		Dirt or water in fuel system.	Clean and flush entire fuel system.
		Air cleaner plugged.	Service air cleaner.
4)	Engine misses or runs erratically.	Faulty spark plug.	Re-gap or replace spark plug.
		Worn, pitted ignition breaker points.	
		Mal-adjusted breaker points.	

TROUBLE SHOOTING

MODEL	TYPE OF FAILURE	CAUSE	SOLUTION
5)	Engine backfiring.	Carburetor out of adjustment. Sticky intake valve. Loose cylinder head or blown head gasket.	Re-adjust carburetor.
6)	Engine knocking.	Improper fuel. Crankcase oil level low. Engine overloaded.	Use only fresh, regular gasoline. Fill to proper level. If knock has developed due to running engine out of oil, have your dealer check the connecting rod bearing. Reduce load — use slower ground speed. Avoid overloading engine.
7)	Engine loses power.	Restricted air filter. Too much oil in crankcase. Overheating. Choke partly closed. Carburetor out of adjustment. Dirt or water in fuel system. Faulty spark plug. Worn, pitted ignition breaker points. Mal-adjusted breaker points. Engine overloaded. Faulty engine valves or piston rings. Breather assembly plugged.	Service the air cleaner. Check oil level — drain excess if over full. Remove shrouds — clean dirt and grease from engine fins and shrouds. Adjust throttle choke control cable. Adjust carburetor. Clean and flush entire fuel system. Re-gap or replace spark plug. Reduce load — use slow ground speed — avoid overloading engine.
8)	Engine smoking excessively at exhaust.	Dipstick not tight.	Push dipstick down until the cap snaps into place.
9)	Tractor unstable on slopes, when turning or on rough terrain.	Tire pressure incorrect. Turning too fast and too short. Traveling too fast and turning too short on hillsides.	Inflate tires as recommended. Slow down. Slow down.

TROUBLE SHOOTING

MODEL	TYPE OF FAILURE	CAUSE	SOLUTION
10)	Tractor will not move with engine running.	Free-wheeling valve open.	Close free-wheeling valve.
		Transmission oil level low.	Add transmission oil to proper level and bleed air from the system.
		Hydrostatic control linkage out of adjustment.	Adjust hydrostatic control linkage.
		Drive belt loose or damaged.	Tighten or replace belt as required.
		Hydrostatic transmission overheating.	Fan on backwards — See page 61 for proper installation.
11)	Tractor creeps with hydrostatic control lever in neutral.	Hydrostatic control linkage out of adjustment.	Adjust hydrostatic control linkage.
12)	Hydrostatic control linkage will not stay in adjustment.	Improper operation — attempting to move hydrostatic control lever with neutralizer pedal depressed.	Use neutralizer pedal for emergency stops only. Keep foot off the pedal during normal operation.
13)	Improper steering.	Tires improperly inflated.	Inflate tires as recommended.
		Hard steering.	Lubricate properly — check and adjust toe-in.
		Excessive steering wheel play.	Replace worn ball joint assemblies. Tighten steering gears.
14)	Excessive front tire wear.	Bent or damaged spindles, tie rod or drag link.	Replace damaged parts.
		Linkage out of adjustment.	Adjust linkage.
15)	Tractor moves too slow or not at all.	Drive belts loose or damaged.	Tighten or replace belts as required.
16)	Cannot shift gears.	Shift lever mal-adjusted. Clutch needs adjustment.	Adjust clutch as recommended.
17)	Hard to shift gears or gears clash.	Clutch needs adjustment.	Adjust clutch as required.
		Improper operation of clutch-brake pedal.	See OPERATION section of manual.
		Shifting while in motion.	Do not shift gears with tractor in motion. See OPERATION section.
18)	Mower blades do not turn with implement power clutch engaged.	PTO drive belt loose or damaged.	Tighten loose belt or replace if damaged or stretched beyond adjustment.
		Mower drive belt or outer drive belt broken or stretched beyond adjustment.	Replace belt.

TROUBLE SHOOTING

MODEL	TYPE OF FAILURE	CAUSE	SOLUTION
19)	Mower vibrates excessively.	Blade mounting bolts loose.	Tighten mounting bolts as recommended (50-60 ft.-lbs. torque).
		Blades bent, damaged or out of balance.	Replace bent, damaged or out-of-balance blades.
		Left or right spindles bent or bearings damaged.	
		Drive belt worn irregular or damaged.	Replace drive belt.
20)	Cut grass uneven.	Mower not leveled.	Level as prescribed in MOWER ADJUSTMENT section.
		Forward pitch or blades incorrect.	Adjust blade pitch as prescribed in MOWER ADJUSTMENT section.
		Mowing too fast for conditions.	Slow down.
		Improper mowing technique.	Read MOWER OPERATION section.
		Blades or spindles bent.	Replace bent blades.
		Drive belt slipping.	Replace belt.
21)		Blade mounting bolt loose.	Tighten mounting bolts to 50-60 ft.-lbs. torque.
22)	Ragged cut or leaving streaks.	Blades dull or damaged.	Sharpen dull blades — replace damaged blades.
		Operating engine too slow.	Operate engine at full throttle.
		Material build-up under deck.	Keep underside of deck clean.
		Traveling too fast.	Slow down.
		Grass too wet.	Wait until grass dries.
		Cutting exceptionally tall grass.	Mow tall grass twice — first time with blades as high as possible. Finish with blades set at normal height.
		Drive belts slipping.	Check PTO drive belt adjustment. Replace if stretched beyond adjustment. Replace mower drive belt and outer blade drive belt.

TROUBLE SHOOTING

MODEL	TYPE OF FAILURE	CAUSE	SOLUTION
23)	Mower scalps the ground.	Cutting height too low.	Increase cutting height.
		Travelling too fast for conditions.	Slow down.
		Rollers worn excessively.	Replace worn rollers.
		Linkage damaged or binding.	Repair damaged linkage and free-up any binding.
		Improper mowing techniques.	Read MOWER OPERATION section.
		Bent blade or spindle.	Replace bent blade.
24)	Mower stalls easily.	PTO drive belt slipping.	Adjust belt. Replace if worn beyond adjustment.
		Mower drive belt or outer blade drive belt slipping.	Replace worn belt.
		Engine speed too slow.	Operate engine at full throttle and control ground speed with hydrostatic control lever or select a lower gear on gear shift models.
		Travel speed too fast.	Slow down.
		Blades dull.	Sharpen blades.
		Incorrect blade pitch.	Adjust level and pitch so front of blades is lower than rear of blades.
25)	Tractor wheels digging up the lawn.	Turning too fast and too short.	Decrease travel speed when turning.
		Tires over-inflated.	Adjust tire pressure.

ENGINE LISTINGS

PRODUCT: 29,000 Series Tractor

MODEL YEAR	MICRO FICHE CARD NO.	MODEL NUMBER	SERIAL NUMBER AND UP	ENGINE H.P. MAKE STARTER	ARIENS IBAI NUMBER	ORIGINAL ENGINE NUMBER	REPLACEMENT ENGINE			REPLACEMENT SHORT BLOCK		
							ENGINE NUMBER	REMOVE PARTS	ADD PARTS	SHORT BLOCK NUMBER	REMOVE PARTS	ADD PARTS
1973-1974	12	929001 S-8 Gear	000101	8 Briggs Elec.	82089	191707-0636	191707-1026	261306	261129, 66538	(V99) 390649 R		
1973-1974	12	929002 S-8 Hydro	000101	8 Briggs Elec.	82089	191707-0636	191707-1026	261306	261129, 66538	(V99) 390649 R		
1974-1975	12	929001 S-8 Gear	000101	8 Briggs Elec.	82089	191707-0636	191707-1026	261306	261129, 66538	(V99) 390649 R		
1974-1975	12	929002 S-8 Hydro	000101	8 Briggs Elec.	82089	191707-0636	191707-1026	261306	261129, 66538	(V99) 390649 R		
1975-1976	12	929001 S-8 Gear	000101	8 Briggs Elec.	82089	191707-0636	191707-1026	261306	261129, 66538	(V99) 390649 R		
1975-1976	12	929002 S-8 Hydro	000101	8 Briggs Elec.	82089	191707-0636	191707-1026	261306	261129, 66538	(V99) 390649 R		
1976-1977	12	929001	001478	8 Briggs Elec.	82089	191707-0636	191707-1026	261306	261129, 66538	(V99) 390649 R		
1976-1977	12	929002	002326	8 Briggs Elec.	82089	191707-0636	191707-1026	261306	261129, 66538	(V99) 390649 R		
1977-1978	12	929001	001709	8 Briggs Elec.	82089	191707-0636	191707-1026	261306	261129, 66538	(V99) 390649 R		
1977-1978	12	929002	002780	8 Briggs Elec.	82089	191707-0636	191707-1026	261306	261129, 66538	(V99) 390649 R		

BELT CROSS REFERENCE

S-8 GEAR

YEAR	INTERMEDIATE	TRANSMISSION	PTO	36" MOWER	36" SNO-THRO
1974-78	72103	72100	72101	72077	72104

S-8 HYDRO

YEAR	INTERMEDIATE	TRANSMISSION	PTO	36" MOWER	36" SNO-THRO
1974-78	72102	72101	72077	72104	72104

ASSEMBLY INSTRUCTIONS

36" SNO-THRO — MODEL 829003

The 36 ST Sno-Thro is designed for use on all Ariens 929000 series Lawn Tractors.

"Left" and "right" are always determined from a position facing the direction of forward travel during operation.

1. Apply a light coating of grease to the underside of chute base ring and position on the chute and deflector assembly on the auger housing as shown in Figure 7. The notches in the chute base must engage the spiral control as shown.

Place the three chute guides over the base ring as shown in Figure 7 and align the holes in the guides with the holes provided in the auger housing. Secure with $5/16"$ x $3/4"$ carriage bolts, lockwashers and nuts. Install nuts to the outside at Point A. Install nut to the inside at Point B.

Turn the spiral control to assure that the chute turns freely. If there is any binding, it may be necessary to pry the openings in the chute guides apart until the chute turns freely.

2. Secure the drift cutters, Figure 6, to the auger housing with $3/8"$ x $3/4"$ capscrews, lockwashers and nuts.

3. Install the skid shoes as shown in Figure 6. Install each shoe at the same height. Secure with $3/8"$ x $1"$ carriage bolts, flat washers, lockwashers and nuts. Place flat washers next to the slots.

4. Insert chute crank through the hole in the chute crank support, (Figure 6) and insert opposite end into universal joint on the snow head, Figure 10. Secure with hairpin cotter.

5. Remove front running board support mounting hardware on the right side of the tractor. Position chute crank support as shown in Figure 6. Secure with $3/8"$ x $1 1/4"$ capscrews, lockwashers and nuts.

6. Remove the single groove mower drive sheave from under the tractor and replace with the double groove drive sheave as shown in Figure 9. Secure with the square key and snap ring installed on the original sheave.

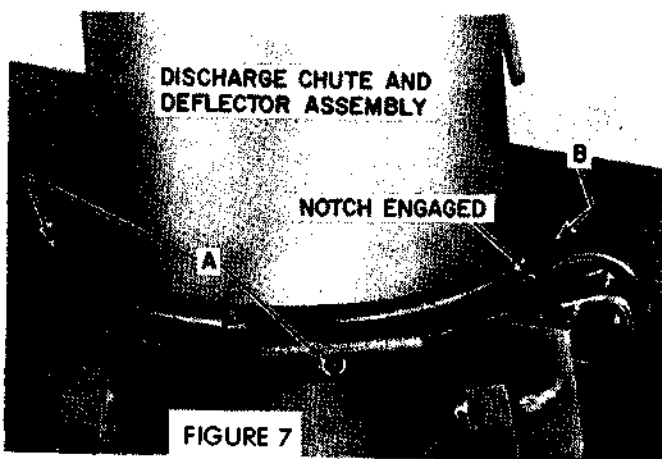

CAUTION: The upper sheave must be used to drive the mower. The lower sheave must be used to drive the sno-thro.

7. Attach lift arm to the lift bracket, Figure 8, using a spacer, $3/8"$ x $1 1/2"$ capscrew, three flat washers, lockwasher and nut. Insert spacer through hole in lift arm. Use one flat washer at each end of the spacer. Use the third flat washer next to the slot on the lift bracket. Secure with lockwasher and nut.

8. Loosen belt guides A, Figure 11, and install the drive belt as shown. After installing the belt move belt guides to a position $1/8"$ from sheave edge and belt when belt is tight and secure the locking nuts.

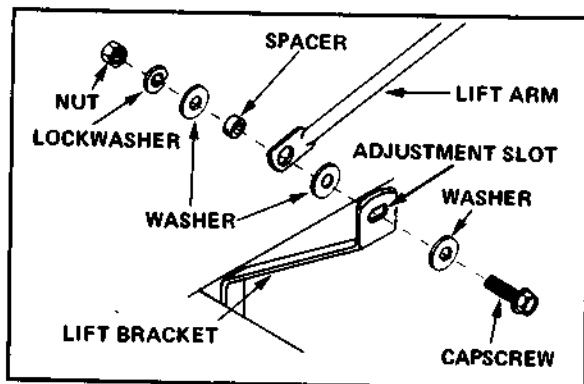

FIGURE 8

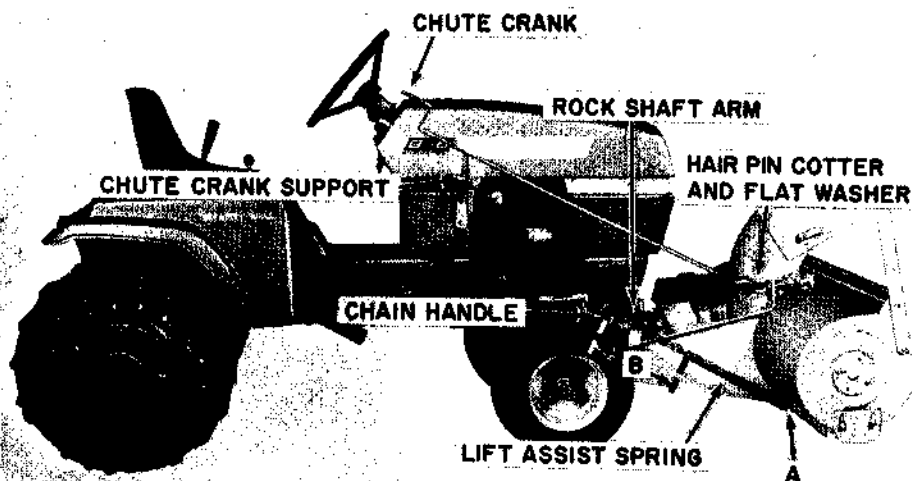

FIGURE 6

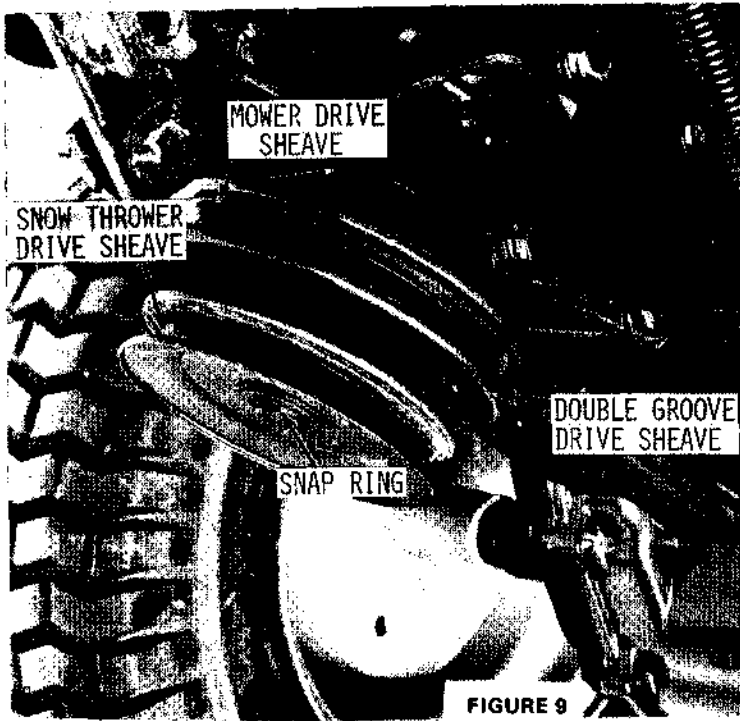

FIGURE 9

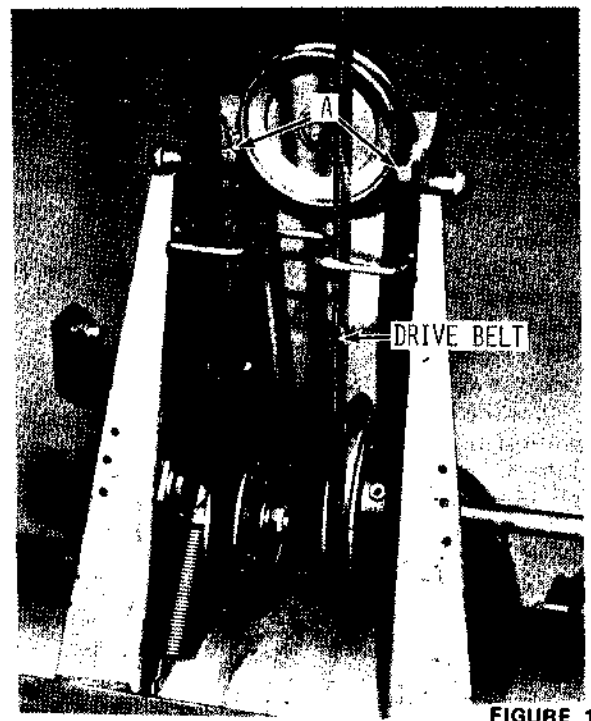

FIGURE 11

INSTALLATION

36" SNO-THRO

1. Place sno-thro mounting, pivots in the tractor saddle brackets and secure with the latches and locks, Figure 10.
2. Lower attachment lift lever and secure lift arm to the lever with a hair pin cotter.
3. Attach lift assist springs as shown in Figures 6 and 10. *NOTE: The springs can be attached to the sno-thro frame in any of three different mounting holes. The front hole provides maximum flotation and easiest lifting of the sno-thro. The rear hole provides*

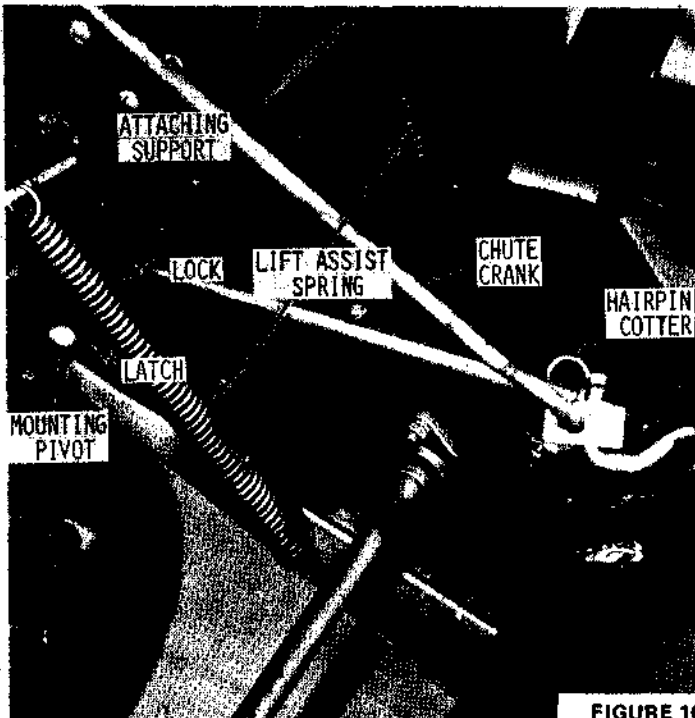

FIGURE 10

the least flotation and may be desirable in hard-packed snow.

4. Insert chute crank through the hole in the chute crank support, Figure 6, and insert the opposite end through the universal joint on the snow head, Figure 10, and secure with a hair pin cotter.
5. Check belt to be sure it is still in position as shown in Figure 11. Install belt onto sno-thro sheave, Figure 9, on the tractor.

Fill our pre-warranty registration card and mail to Ariens Company.

INSTRUCT THE CUSTOMER THOROUGHLY ON HOW TO OPERATE THE SNO-THRO. POINT OUT ALL SAFETY PRECAUTIONS AS SHOWN IN THE OWNERS MANUAL. CAUTION THE CUSTOMER TO KEEP ALL GUARDS AND SHIELDS IN PLACE WHEN OPERATING AND TO READ THE OWNERS MANUAL BEFORE OPERATING THE UNIT.

SAFETY FIRST

IMPORTANT



BE A SAFE OPERATOR. Before attempting to operate the sno-thro, thoroughly acquaint yourself with:

1. The safety information in the Owner's Manual.
2. The operating instructions in the Owner's Manual.
3. The controls on the tractor and sno-thro.

Unsafe operating practices and improper use of the tractor and sno-thro on the part of the operator can result in injuries. Observe the following safety precautions at all times:

1. Clear work area of debris and objects which might be picked up and thrown.
2. Stop and inspect for damage after striking a foreign object. Repair any damage before re-starting and operating the sno-thro.
3. Never direct snow discharge toward bystanders nor allow anyone near the machine while in operation.
4. When the tractor is parked, stored, or left unattended, always lower the sno-thro so it is resting on the ground or floor. If left in a raised position, the manual lift lever could accidentally be moved allowing the attachment to fall and injure someone.
5. NEVER ATTEMPT TO CLEAR AUGER OR DISCHARGE CHUTE WHILE ENGINE IS RUNNING. DIS-ENGAGE THE PTO CLUTCH, STOP THE ENGINE AND REMOVE THE IGNITION KEY.
6. Disengage PTO clutch when transporting.
7. Disengage PTO clutch and stop the engine when changing angle of the deflector.
8. Give complete and undivided attention to the job at hand so complete control of the tractor and sno-thro is maintained at all times.
9. Learn how to stop the tractor quickly.
10. Drive slowly over rough ground and on slopes. Be alert for holes, ditches and other irregularities that could cause the tractor to overturn.
11. Avoid steep hillside operation which could cause the tractor to overturn.
12. Reduce speed when turning so there is no danger of tractor overturning.
13. Always look behind you before backing up.
14. Maintain proper transmission oil level to prevent loss of braking control on hydrostatic tractors.
15. Do not allow children to operate the sno-thro.
16. Do not allow adults to operate the sno-thro without proper instruction.

17. Do not allow passengers to ride on tractor at any time.
18. Do not operate tractor in any position other than in the operator's seat.
19. Do not stop or start suddenly when going up hill or down hill.
20. Never operate tractor engine in a closed building.
21. Re-fuel tractor outdoors with the engine shut off. Replace gas cap securely. Use an approved gasoline container. Do not smoke when handling fuel. Avoid spilling.
22. Never touch muffler, exhaust pipe or engine until they have had time to cool after operating the engine.
23. Dress appropriately — wear relatively tight fitting clothing when operating the tractor. Loose or torn clothing can catch in moving parts or controls.
24. Use only approved draw bar hitch points to pull loads.

CONTROLS

TRACTOR

Familiarize yourself thoroughly with the tractor controls as outlined in the section under controls in the Owner's Manual supplied with the tractor.

SNO-THRO (Figure 13)

6. **Chute Crank** — This control regulates the direction of snow discharge.
9. **Deflector** — Controls the height the snow can be thrown.
8. **Runners** — Controls the distance the scraper blade is held above the surface being cleared.

OPERATION

The optional wheel weights and tire chains provide the extra traction needed for soft ground conditions, ice and heavy snow removal jobs. These accessories are not included with the sno-thro but can be purchased through your Ariens dealer.

The auger, auger drive chain and gearbox are protected by a shearbolt designed to shear if a solid object enters the auger. Do not install substitutes.

Make visual check with regards to safety precautions, obstructions, lubrication, and maintenance before starting the engine.

TRACTOR

For operation see the section on operation in the Owner's Manual packed with the tractor.

SNO-THRO

1. Adjust the deflector (9) Figure 13, to the desired height before starting engine. Raising the deflector will cause snow to be thrown the greatest distance. Lowering the deflector will shorten the distance.

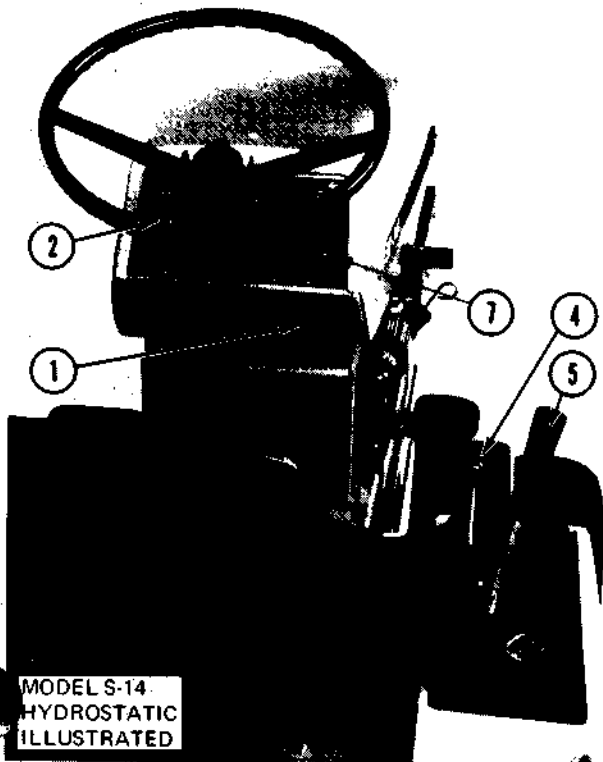
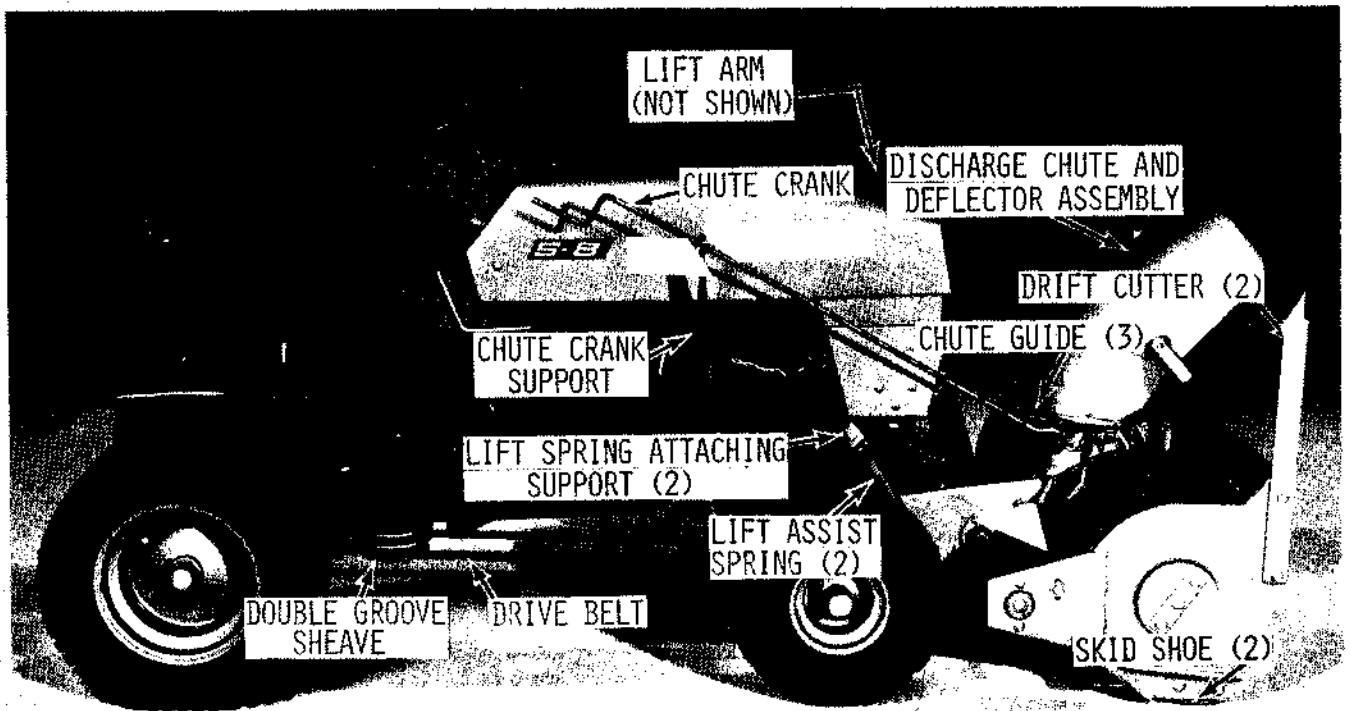

FIGURE 12



2. Turn the chute crank (6) Figure 13, so that snow will be thrown in the desired direction.

3. Lower the sno-thro and start the auger rotating by pulling the implement power control switch (1) Figure 12, "out" with the engine running at 1/3 fast throttle (7) Figure 12. Increase engine speed to full throttle after the sno-thro auger is rotating.

On the S-8 and S-12 tractor the sno-thro is raised by pulling the manual lift lever (3) Figure 13, until the latch snaps into a notch of the control quadrant. To lower sno-thro, pull lever slightly rearward, depress button and move the lever forward.

On the S-14 and S-16 tractors with the hydraulically operated lift (4) Figure 12, raise the attachment by moving the control lever to the UP position. The sno-thro may be held in any position desired by allowing the lever to stay in the "hold" position. While operating the sno-thro, the lever should be moved to the "float" position, to permit the attachment to follow the contour of the ground.

4. For maximum snow removal and discharge

operate the engine at full throttle and regulate the travel speed with the hydrostatic control lever and/or shift lever (5) Figure 12 and 13.

ADJUSTMENTS

1. The deflector, Figure 14, has a slotted hole on each side for adjustment. To change the angle of the deflector, loosen the two locking levers. Tighten the locking levers when the deflector is adjusted at the desired angle.

2. The runners, Figure 15, are mounted on slotted holes to provide the desired clearance between the base of the auger housing and the surface of the area to be cleared. When operating on a smooth surface such as cement or asphalt, the runners can be set at the lower end of the slots as shown. When operating on a rough surface such as

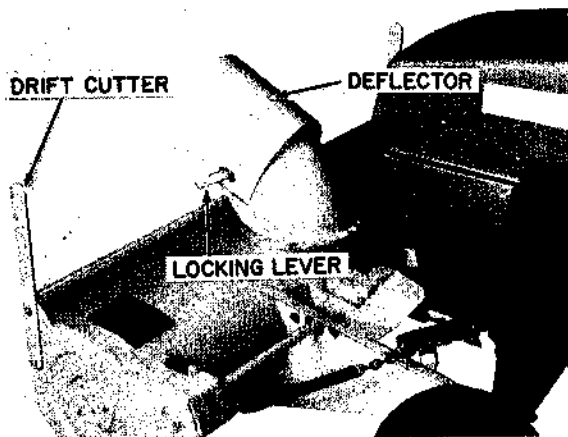

FIGURE 14

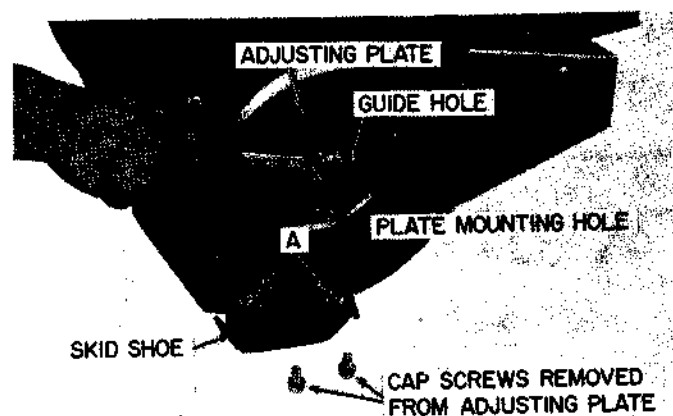

FIGURE 15

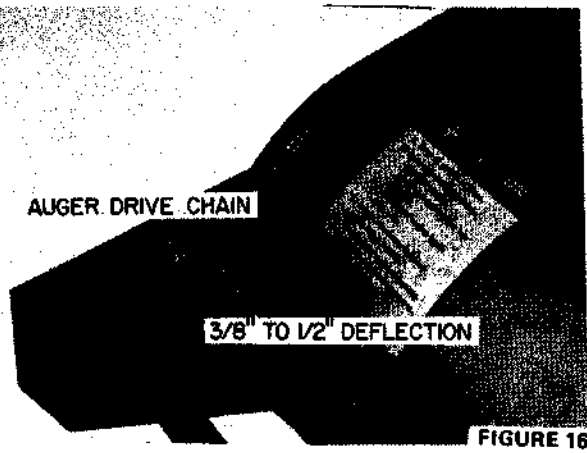

FIGURE 16

gravel or earth, the runners should be set at the upper end of the slots to prevent foreign material from entering and possibly damaging the snow thrower. Adjust the runners by loosening nuts A and moving the shoes up or down as required.

3. The auger drive chain should be adjusted until the chain deflects from 3/8" to 1/2" with finger pressure applied midway between the sprockets, Figure 16. Adjust drive chain as follows:

Remove two cap screws from the adjusting plates on each end of the auger, Figure 15. Place a wrench on the nut welded to the left hand adjusting plate and rotate the plate until proper chain deflection is achieved and the plate mounting holes align with the holes in the auger housing. Rotate the right hand adjusting plate an equal amount. The guide hole shown in Figure 15 is provided on each adjusting plate to assure that both ends of the auger are adjusted evenly.

Recheck chain deflection and readjust if necessary. After obtaining the proper adjustment, secure end plates to the auger housing with the cap screws previously removed.

NOTE: After continued use it may be necessary to remove a half link from the chain and repeat the

above procedure to obtain the proper chain tension.

4. The cutting edge shown in Figure 15 is both reversible and replaceable. If excessive wear is noticed after continued use, the eight mounting bolts can be removed and the plate reversed for double life.

5. **LIFTING RANGE** (36" Sno-Thro only)

The lift range can be adjusted up or down by loosening the 3/8" x 1 1/2" cap screw, Figure 17, on the front of the lift tube. Moving the cap screw forward in the slot will raise the lifting range and may be desirable in deep snow. Moving the cap screw toward the rear of the slot will lower the lifting range thus permitting the cutting edge to follow the ground contour to lower areas but will provide less ground clearance in the raised position.

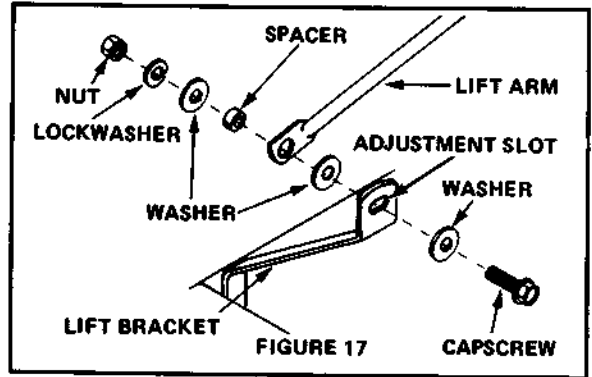

FIGURE 17

LUBRICATION

Once a month during season or every 25 operating hours, lubricate the auger drive chain, Figure 16, with heavy duty chain lubricant.

Grease discharge chute base shown in Figure 14 after each use.

TROUBLE SHOOTING

MODEL	TYPE OF FAILURE	CAUSE	SOLUTION	SERVICE BULLETIN OR LETTER
1)	Cannot completely clear the snow area.	Not following a proper pattern of operation.	Follow suggestions outlined in "Methods of Snow Removal" section.	
2)	Insufficient traction and maneuverability.	Tire chains and wheel weights required.	Install the optional tire chains and wheel weights for better traction. Add two sets of wheel weights if necessary.	
		Not removing top layers of snow first in deep snow or drifts.	Follow suggestions outlined in "Operation" section.	
		Travel speed too fast for uneven terrain or ice conditions.	Reduce travel speed.	

TROUBLE SHOOTING

MODEL	TYPE OF FAILURE	CAUSE	SOLUTION
3)	Discharge chute hard to turn or does not turn.	Chute guides binding.	Remove discharge chute and pry guides open enough to allow the chute base to rotate properly.
		Chute base and guides rusted.	Remove chute. Clean rusted areas and apply coating of grease to chute base ring and guides.
		Chute directional worm control damaged.	Repair worm control so the spirals engage notches in the chute base without binding.
		Chute base ring or directional worm control frozen with ice.	Remove ice so that discharge chute turns freely.
4)	Cannot raise or lower the snow thrower.	Selector knob on tractor incorrectly positioned.	Place selector knob in the rear position.
	(S-14 tractors equipped with rear rock shaft).		
5)	Snow thrown too far or not far enough.	Deflector improperly adjusted.	Adjust deflector higher to throw snow further. Adjust lower to decrease throwing distance.
		Discharge chute partially blocked.	Remove obstruction from the chute.
		Engine speed too slow.	Operate engine at full throttle.
6)	Auger plugs.	Travel speed too fast for conditions.	Decrease travel speed to meet conditions.
		Foreign object lodged in auger housing or discharge chute.	Remove obstruction.
		Auger damaged from striking foreign object.	Repair or replace the auger.
		Auger drive chain too loose — jumps sprocket teeth.	Repair or replace chain if damaged. Maintain proper adjustment.
		Tractor P.T.O. drive belts worn excessively.	Replace belt.
		P.T.O. drive shaft universal joints out of phase.	Re-assemble drive shaft so that universal joints are properly phased.
7)	Excessive vibration.	Auger damaged or bent.	Repair or replace auger.
8)	Auger does not rotate.	Sheared shearbolt.	Replace with new shearbolt (N.H. #241287).