

# Service Manual Trucks

Group **37**

Version **01**

Wiring diagram

FH12, FH16 LHD

To be inserted into the binders for FM, FH.

# Foreword

The descriptions and service procedures contained in this manual are based on designs and methods studies carried out up to September 1998.

The products are under continuous development. Vehicles and components produced after the above date may therefore have different specifications and repair methods. When this is judged to have a significant bearing on this manual, supplementary service bulletins will be issued to cover the changes.

The new edition of this manual will update the changes.

In service procedures where the title incorporates an operation number, this is a reference to V.S.T. (Volvo Standard Times).

Service procedures which do not include an operation number in the title are for general information and no reference is made to V.S.T.

The following levels of observations, cautions and warnings are used in this Service Documentation:

**Note:** Indicates a situation, handling or circumstance which should be observed.

**Important:** Indicates a situation, handling or circumstance which should be emphasized so as not to lead to personal injury or damage to property.

**Caution:** Indicates a potentially hazardous situation which, if not avoided, may result in minor or moderate injury or damage to property.

**Warning:** Indicates a potentially hazardous situation which, if not avoided, could result in death, serious injury or major damage to property.

**Danger:** Indicates an imminently hazardous situation which, if not avoided, will result in death or serious injury.

**Volvo Truck Corporation**  
Göteborg, Sweden

**Order number: TSP119544**

© 1998 Volvo Truck Corporation, Göteborg, Sweden

All rights reserved. No part of this publication may be reproduced, stored in retrieval system, or transmitted in any forms by any means, electronic, mechanical, photocopying, recording or otherwise, without the prior written permission of Volvo Truck Corporation.

# Contents

<b>Example of wiring diagram .....</b>	<b>2</b>
<b>Examples of symbols on wiring diagram .....</b>	<b>3</b>
<b>Component wiring diagram index .....</b>	<b>5</b>
<b>Component wiring diagrams .....</b>	<b>7</b>
<b>Illustrations index .....</b>	<b>48</b>
<b>Illustrations .....</b>	<b>49</b>
<b>Circuit card electrical centre .....</b>	<b>104</b>
<b>Fuses on circuit card electrical centre .....</b>	<b>105</b>
<b>Relays on circuit card electrical centre .....</b>	<b>106</b>
<b>Cable harness illustration index .....</b>	<b>107</b>
<b>List of connectors .....</b>	<b>110</b>
<b>List of components .....</b>	<b>117</b>
<b>Abbreviations .....</b>	<b>123</b>
<b>Cable colour code .....</b>	<b>124</b>
<b>Feedback</b>	

## Example of wiring diagram

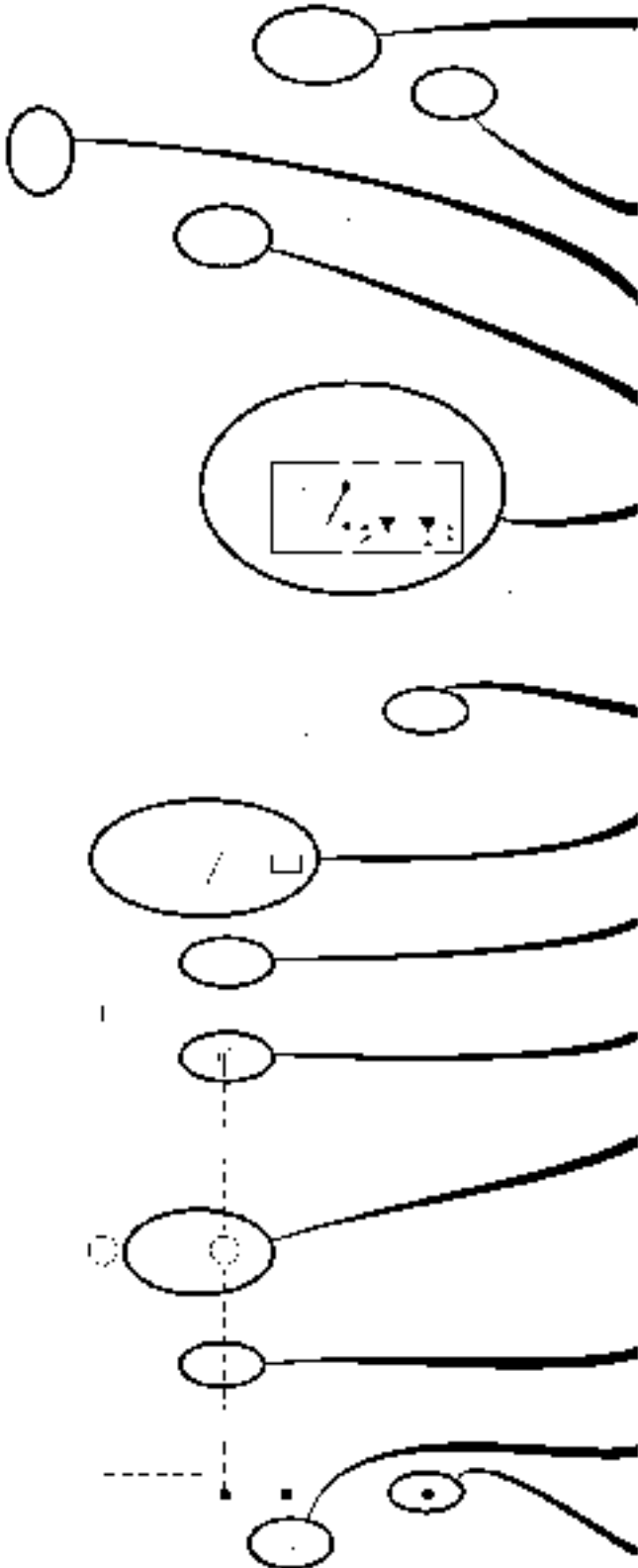

Refer to the list of contents for the designation of the circuit diagram. If the circuit diagram designation is boxed in with broken lines this means that the circuit diagram is not standard on all market or vehicle models.

Seek column.

30 Voltage battery, kl.30.  
15 Voltage with starting key in drive position, kl.15.  
61 Voltage when alternator charges, kl.61.

Reference arrow (for circuit diagram EA, seek column 13).

Switch, comp. no. (104).

Single lines, cables.

Relay, comp. no. (303).

Cable area and colour (0.75 mm<sup>2</sup> blue).

Connector (CLA terminal 4).

Bulb, comp. no. (403)  
A broken line box round the component number shows that the component is not standard on all markets or vehicle models.











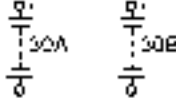

If the line is broken this means the cable is not standard on all markets or vehicle model.

Earth connection point no: 2. and earth terminal no: 4. (see diagram Earth Connections).

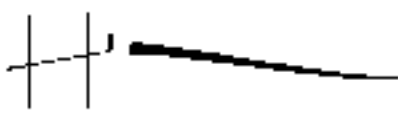
Joint sleeve.

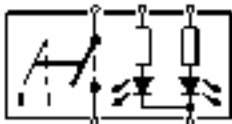
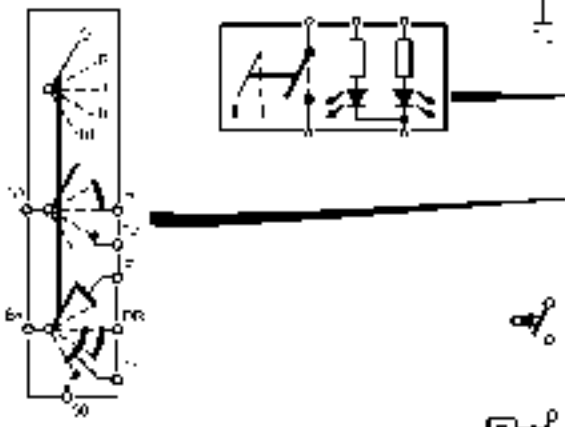
T3009608

# Examples of symbols on wiring diagram

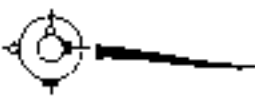
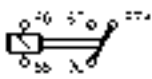
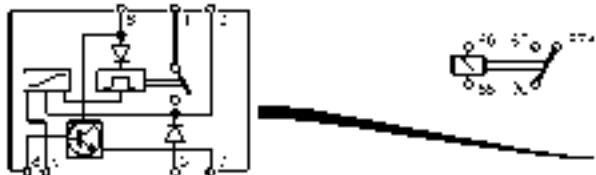
	Battery
	Connector
	Junktion
	Fuse
	Joint sleeve
	Cable
	Twisted cables
	Conductor on circuit card
	Earth connection and cable
	Switch
	Switch, starting switch
	Closing kontakt
	Closing kontakt, pressure-regulated
	Break kontakt, temperature-regulated
	Closing kontakt, time-regulated
	Slip kontakt, horn
	Relay
	Relay with internal circuit diagram

T3009609

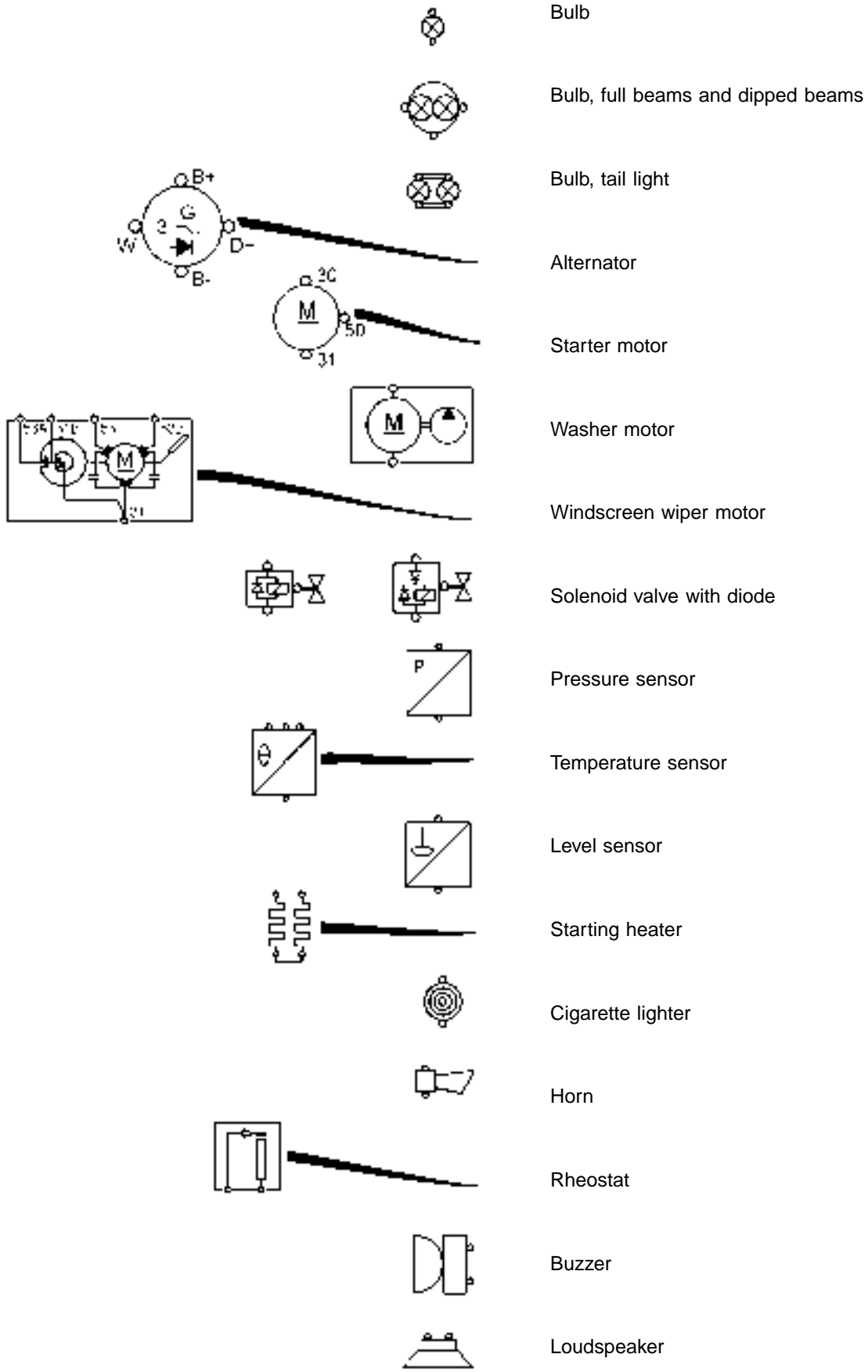

T3009610

## Component wiring diagram index

<b>AA</b>	Power supply, starting system, immobiliser .....	page 7
<b>AC</b>	Vehicle ECU .....	page 8
<b>BL</b>	Engine ECU, fuel injection system, preheating, FH12 .....	page 9
<b>BN</b>	Engine ECU, fuel injection system, preheating, FH16 .....	page 10
<b>CE</b>	Head light, parking light, marker light, DRL .....	page 11
<b>CG</b>	Fog light, rear fog light .....	page 12
<b>CH</b>	Spot light (STD) DRIVL2 .....	page 12
<b>CI</b>	Spot light (EU) DRIVL2EC .....	page 12
<b>CK</b>	Brake light .....	page 13
<b>CL</b>	Trailer controlled exhaust brake .....	page 13
<b>CN</b>	Direction indicator, hazard warning light .....	page 14
<b>EA</b>	Reversing light, reversing warning alarm .....	page 14
<b>ED</b>	Loading light, fifth wheel light .....	page 15
<b>EJ</b>	Roof sign light, L1H1/L2H1 .....	page 15
<b>EK</b>	Roof sign light, L2H2 .....	page 16
<b>EN</b>	Beacon warning light .....	page 16
<b>ER</b>	Interior light, L1H1/ L2H1, alarm clock/timer .....	page 17
<b>ES</b>	Interior light, L2H2/L2H3, alarm clock/timer .....	page 18
<b>EV</b>	Cigarette lighter .....	page 19
<b>EX</b>	12 V power supply .....	page 19
<b>FA</b>	Horn .....	page 19
<b>GA</b>	Wiper, washer .....	page 20
<b>HA</b>	Climate unit .....	page 21
<b>HB</b>	Cab heater, EBERSPÄCHER D1LCC, PH-CAB .....	page 22
<b>HC</b>	Cab and engine heater, WEBASTO THERMO 90, PH-ENGCA .....	page 23
<b>HE</b>	Electrically heated and adjusted seat .....	page 24
<b>HG</b>	Electrically heated mirrors .....	page 24
<b>HH</b>	Electrically operated mirrors .....	page 25
<b>HK</b>	Air dryer .....	page 25
<b>HM</b>	Fuel filter heater .....	page 25
<b>HO</b>	Water separator heater .....	page 25
<b>HP</b>	Electrically cab tilt .....	page 26
<b>JA</b>	Radio .....	page 26
<b>KA</b>	Electrically operated window winders .....	page 27

<b>KB</b>	Electrically sunroof .....	page 27
<b>KE</b>	SRS, air-bag .....	page 28
<b>KH</b>	Central door lock .....	page 28
<b>LD</b>	Power take-off .....	page 28
<b>LE</b>	Double power take-off .....	page 29
<b>LG</b>	Differential lock .....	page 29
<b>LJ</b>	Bogie lift, tag axle lock, RADT-LA .....	page 30
<b>LL</b>	Tag axle lock, RADT-A6S .....	page 30
<b>MA</b>	Bogie lift hydraulic, RADT-AR .....	page 31
<b>MD</b>	Bogie lift hydraulic, with axle load limiter, RADT-AR .....	page 32
<b>ME</b>	Air suspension, 6x2/6x4/8x2/8x4, SUSPL-EC .....	page 33
<b>MF</b>	Air suspension, 4x2, SUSPL-EC .....	page 34
<b>MG</b>	Rear air suspension, 4x2, TRACTOR, SUSPL-EC .....	page 35
<b>NA</b>	Instrument LHS module .....	page 36
<b>NB</b>	Instrument central module with tachograph .....	page 37
<b>NC</b>	Instrument RHS module .....	page 38
<b>NZ</b>	Instrument central module without tachograph .....	page 39
<b>OA</b>	Basic ABS, D-version .....	page 40
<b>OB</b>	ABS/ASR, D-version .....	page 41
<b>PA</b>	Headlight level control .....	page 42
<b>TA</b>	Refrigerator .....	page 42
<b>TB</b>	Central lubrication system .....	page 42
<b>XA</b>	Extra fuses, key switch relay .....	page 43
<b>ZA</b>	Earth connections .....	page 44
<b>ZB</b>	Earth connections .....	page 45
<b>ZD</b>	ADR battery main switch, current limiter .....	page 46
<b>ZE</b>	Air heater EBERSPÄCHER TMD, ADR-FRA .....	page 47



# Component wiring diagrams

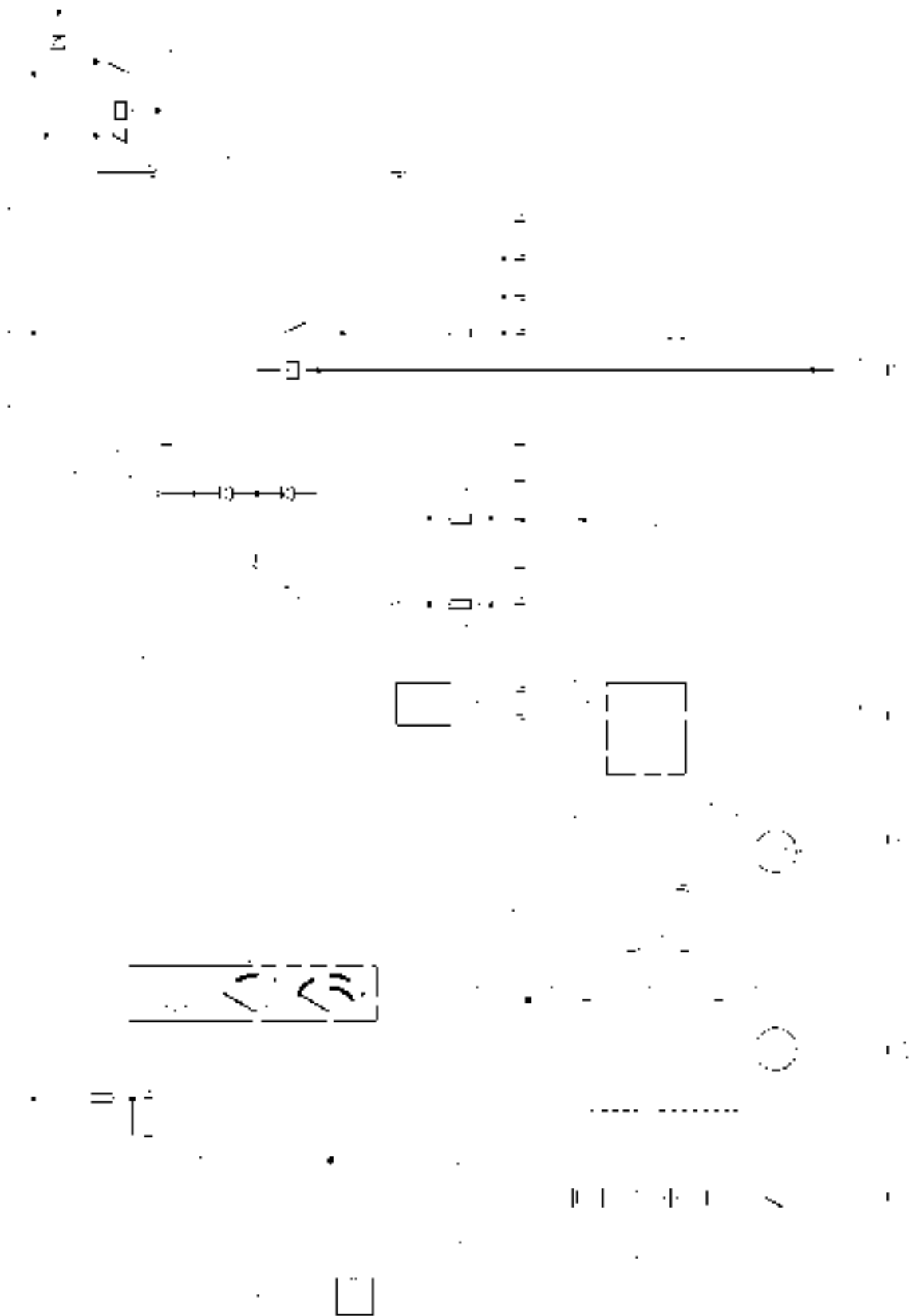

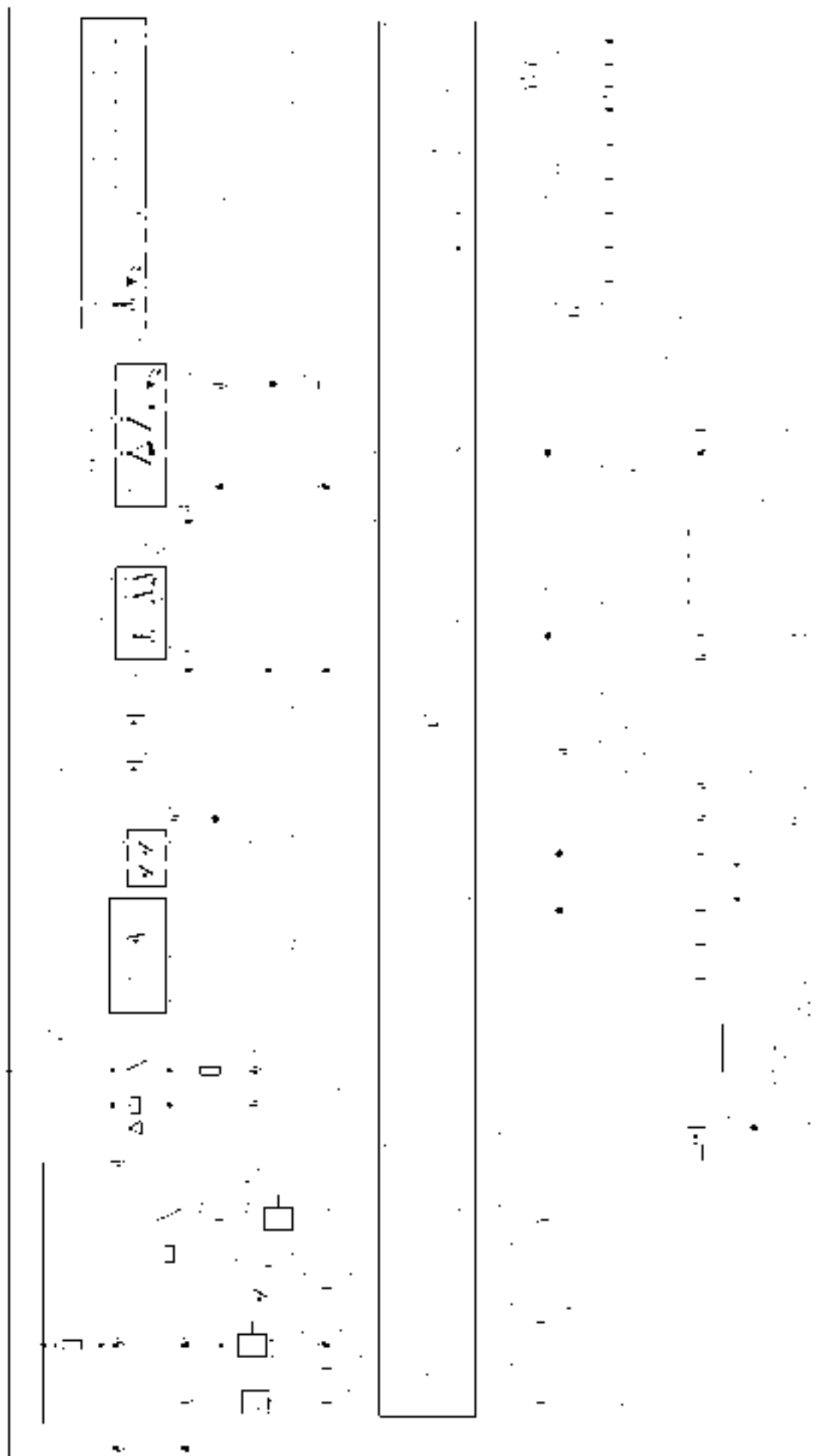

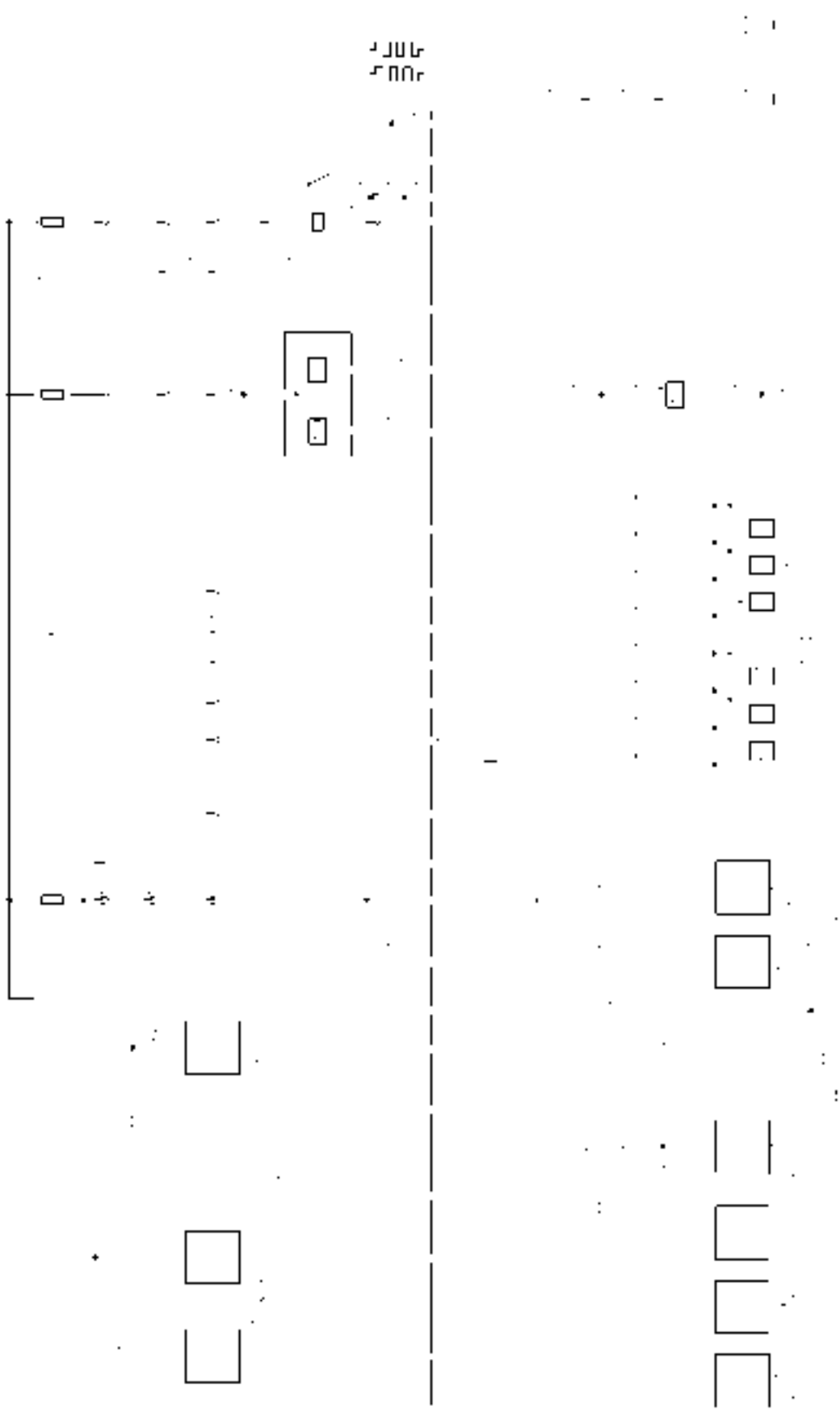

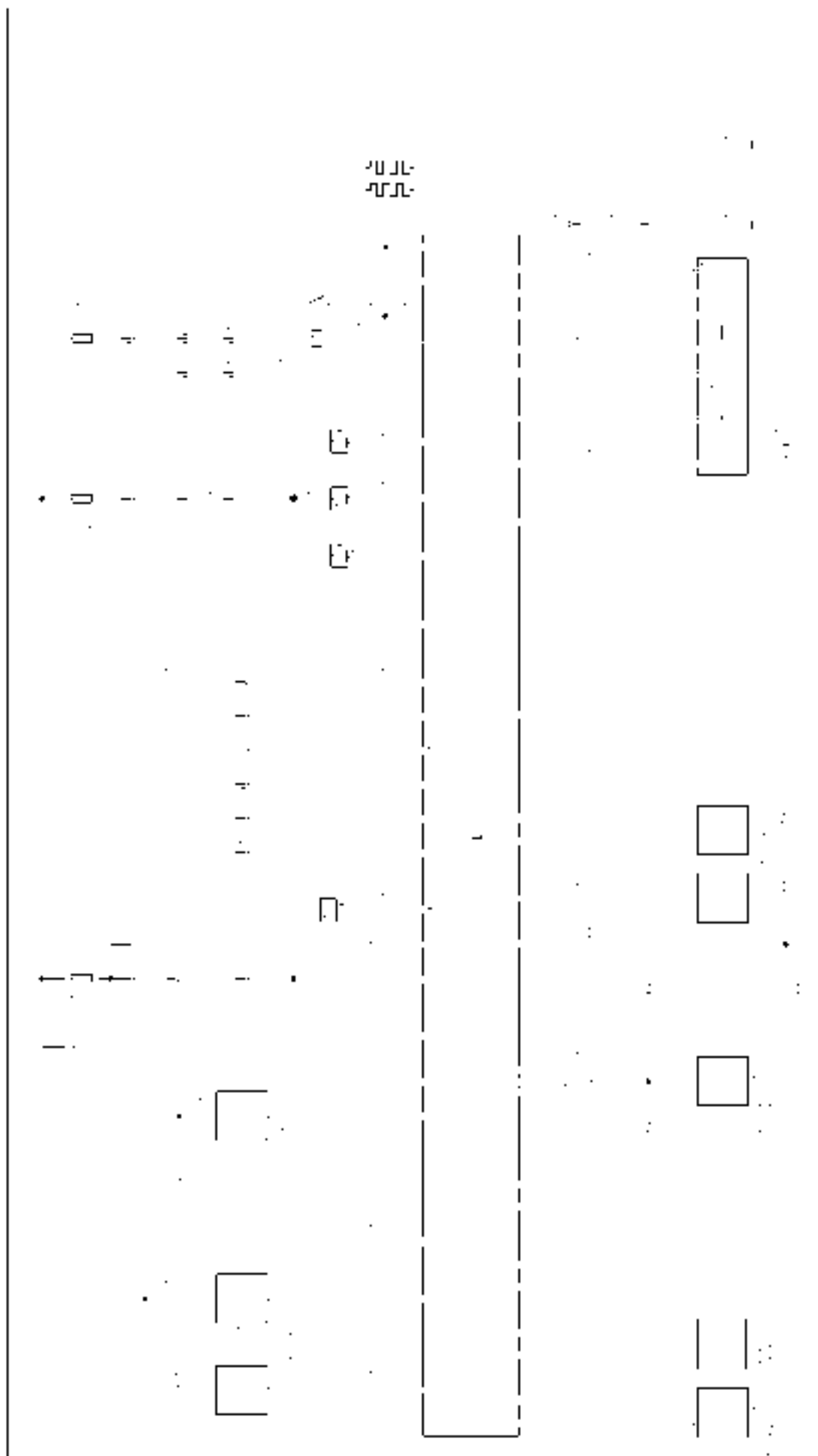

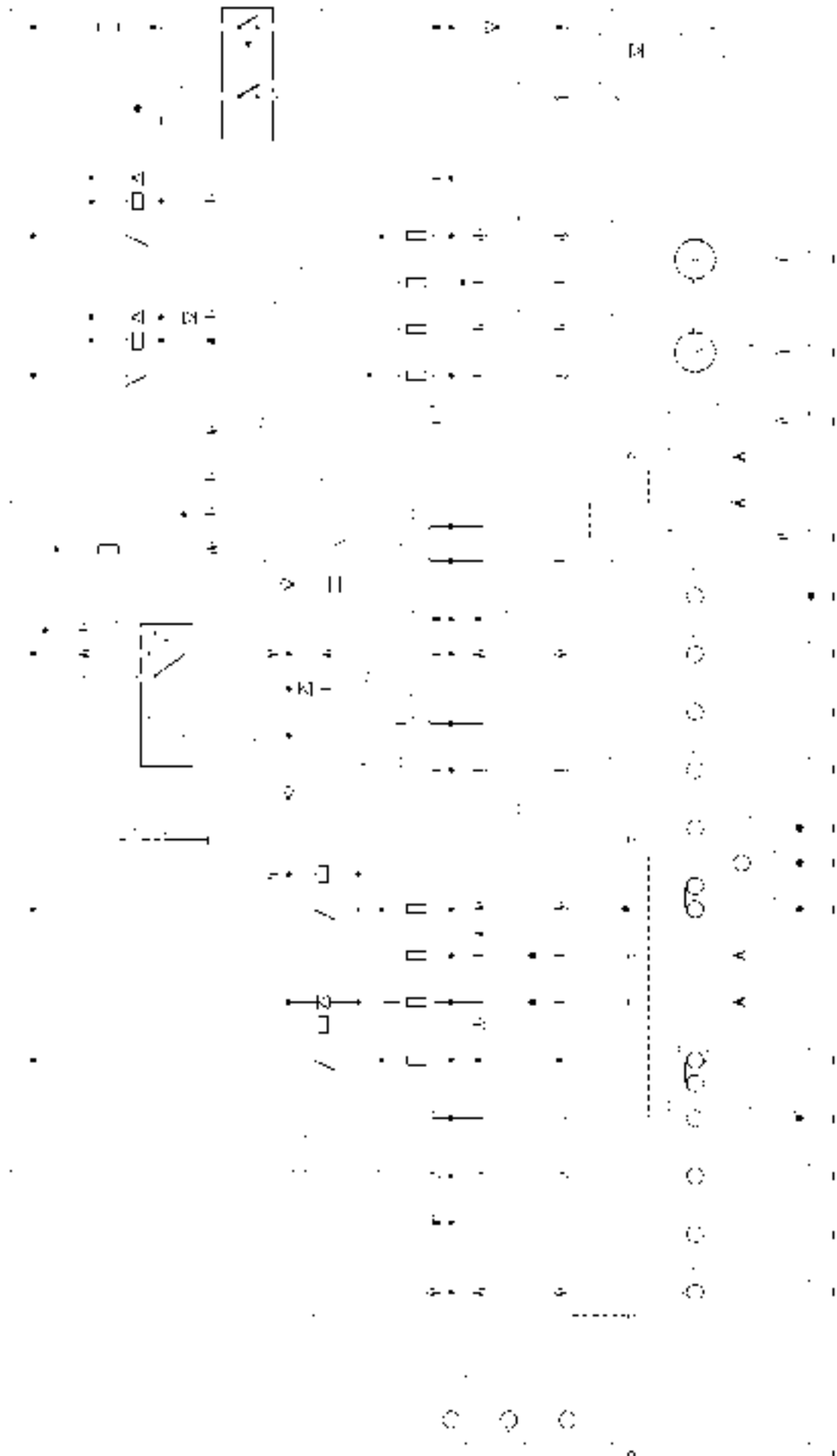

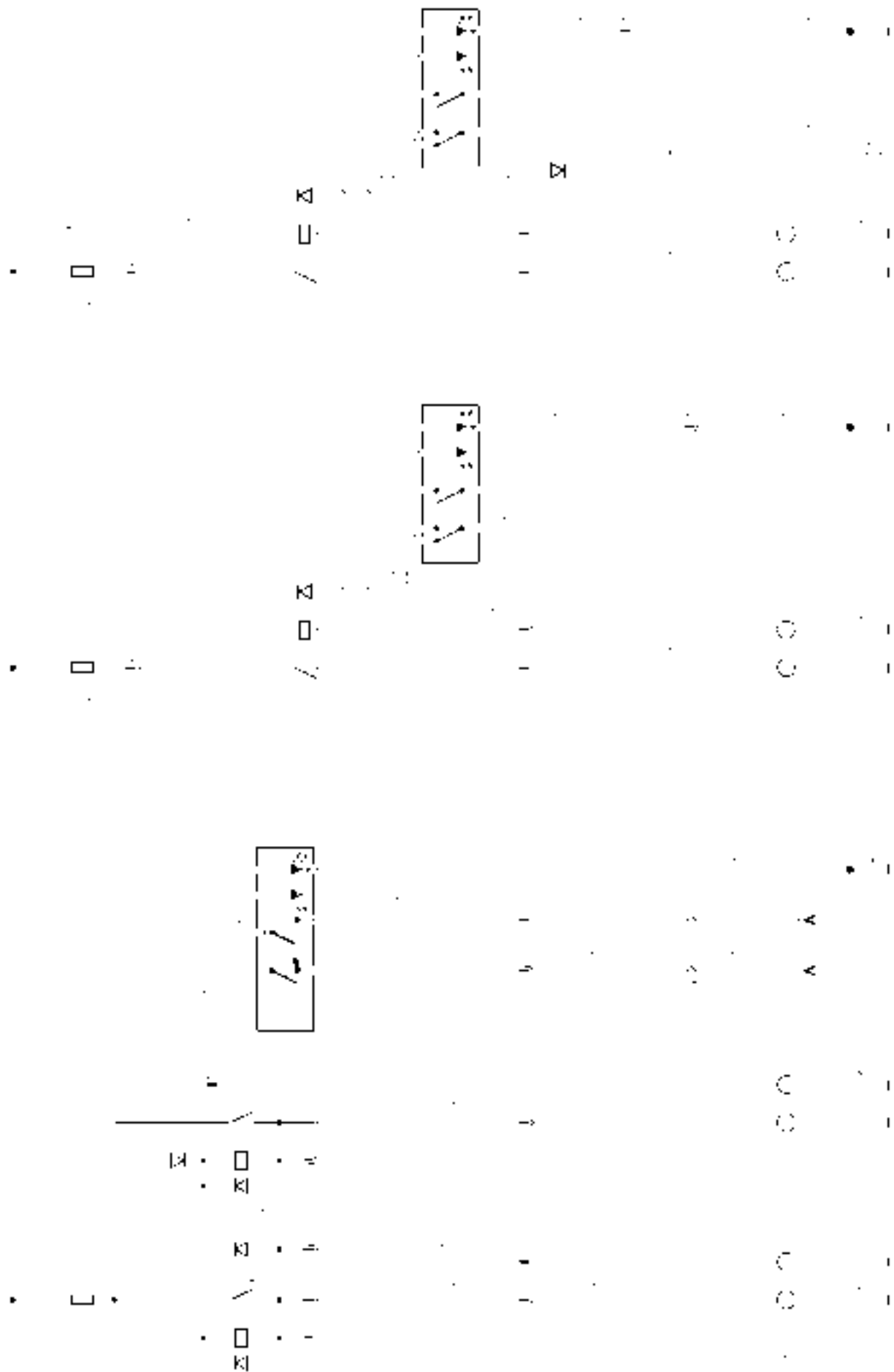

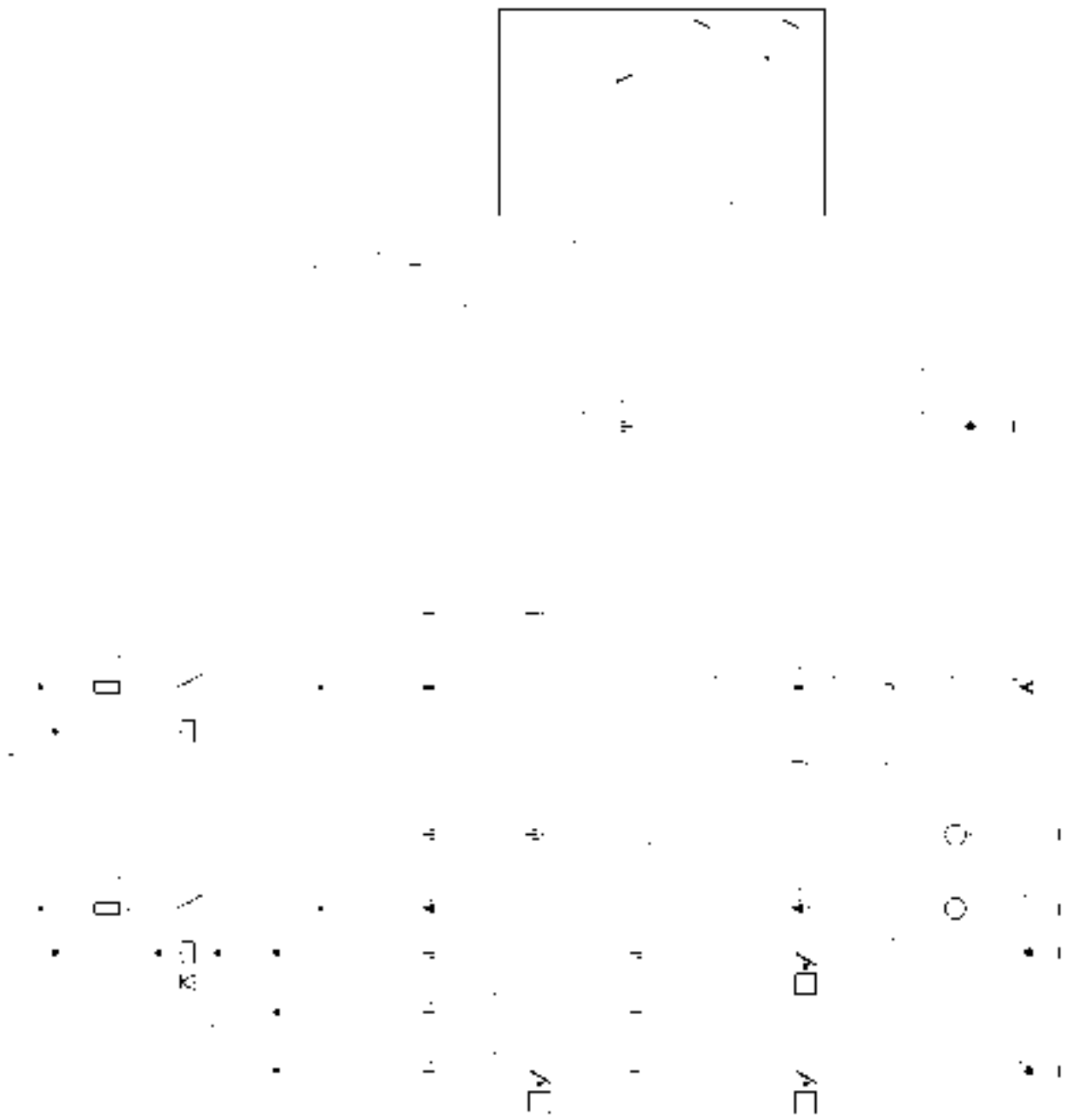

T3010025

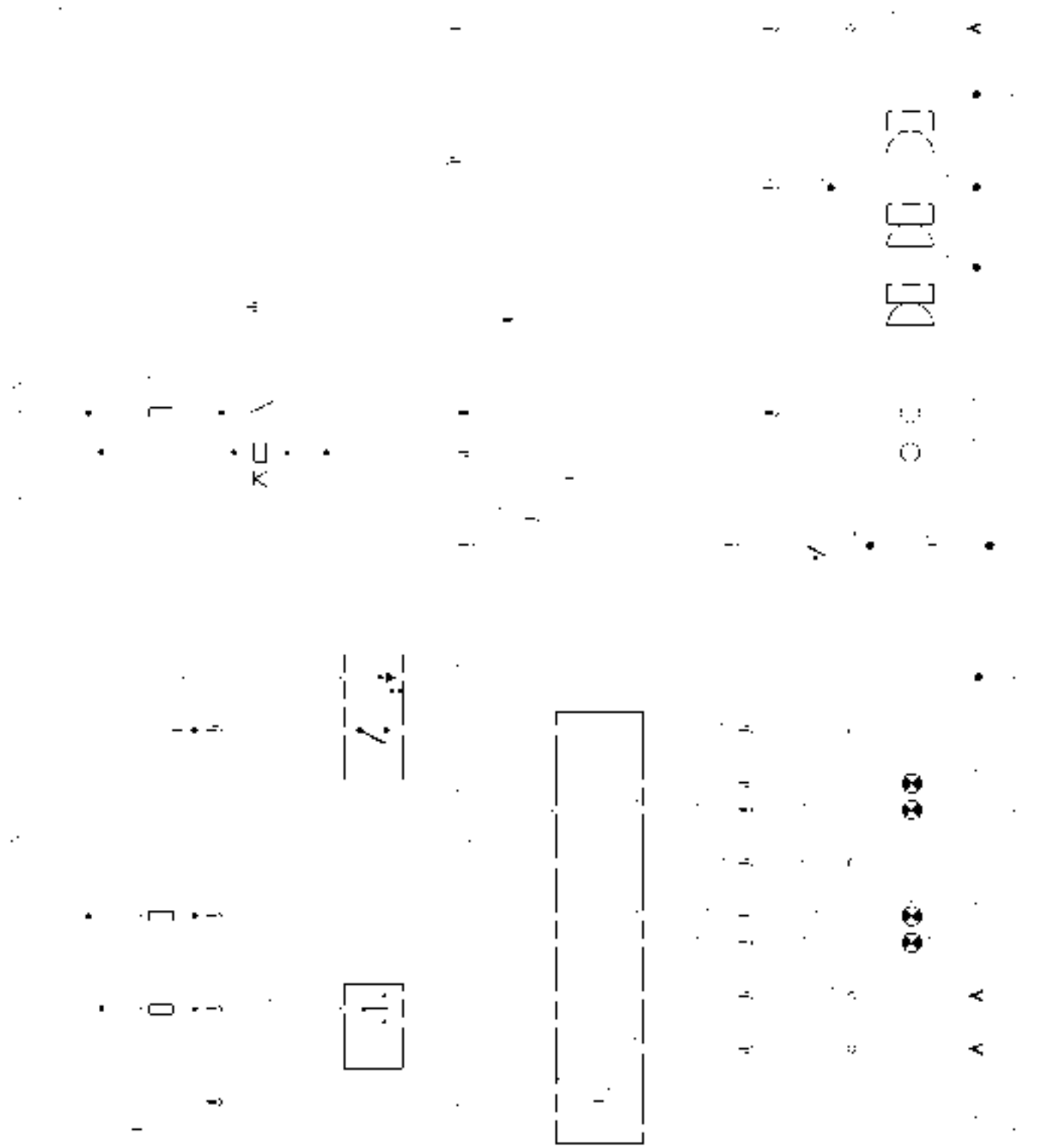

T3010026



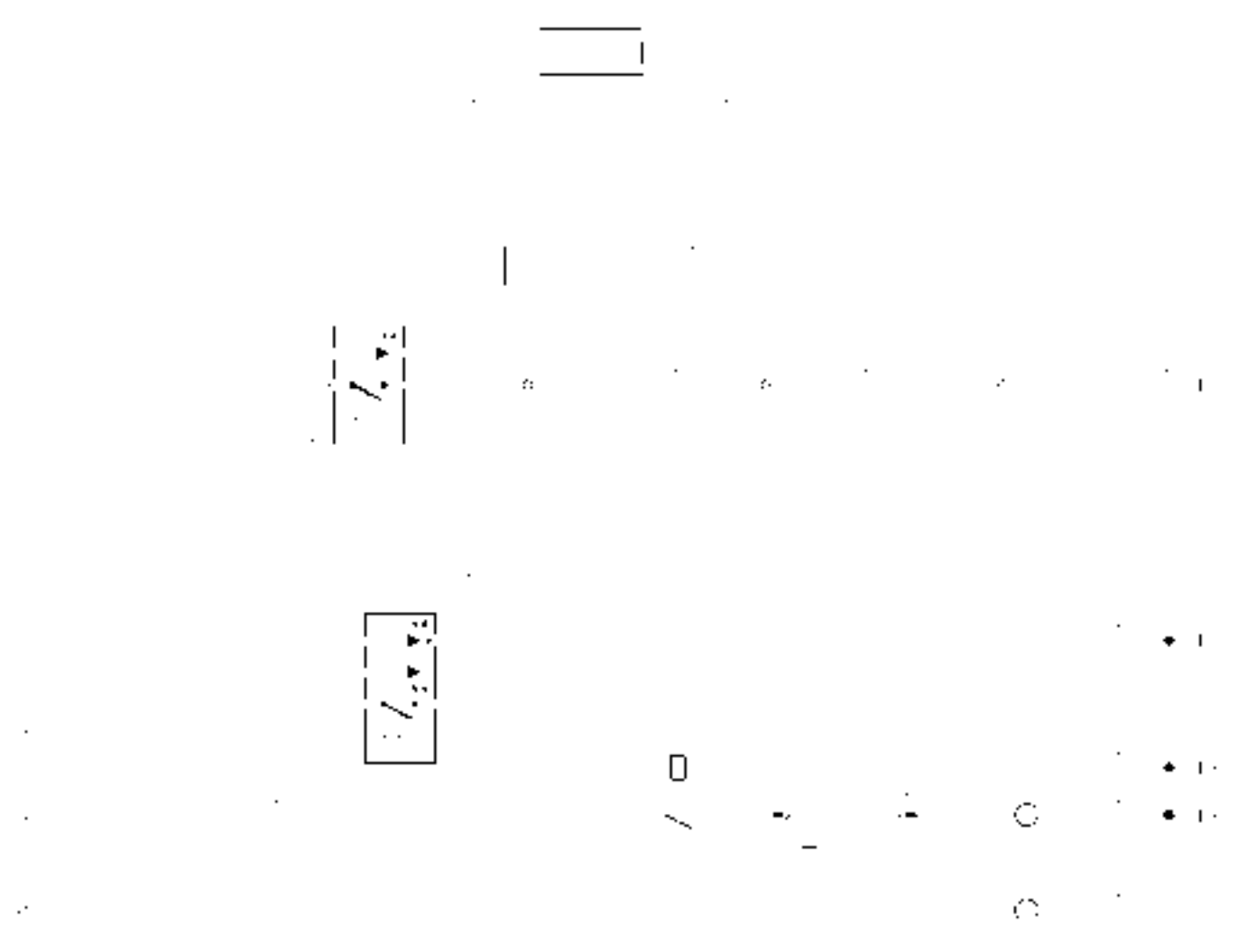

T3010027

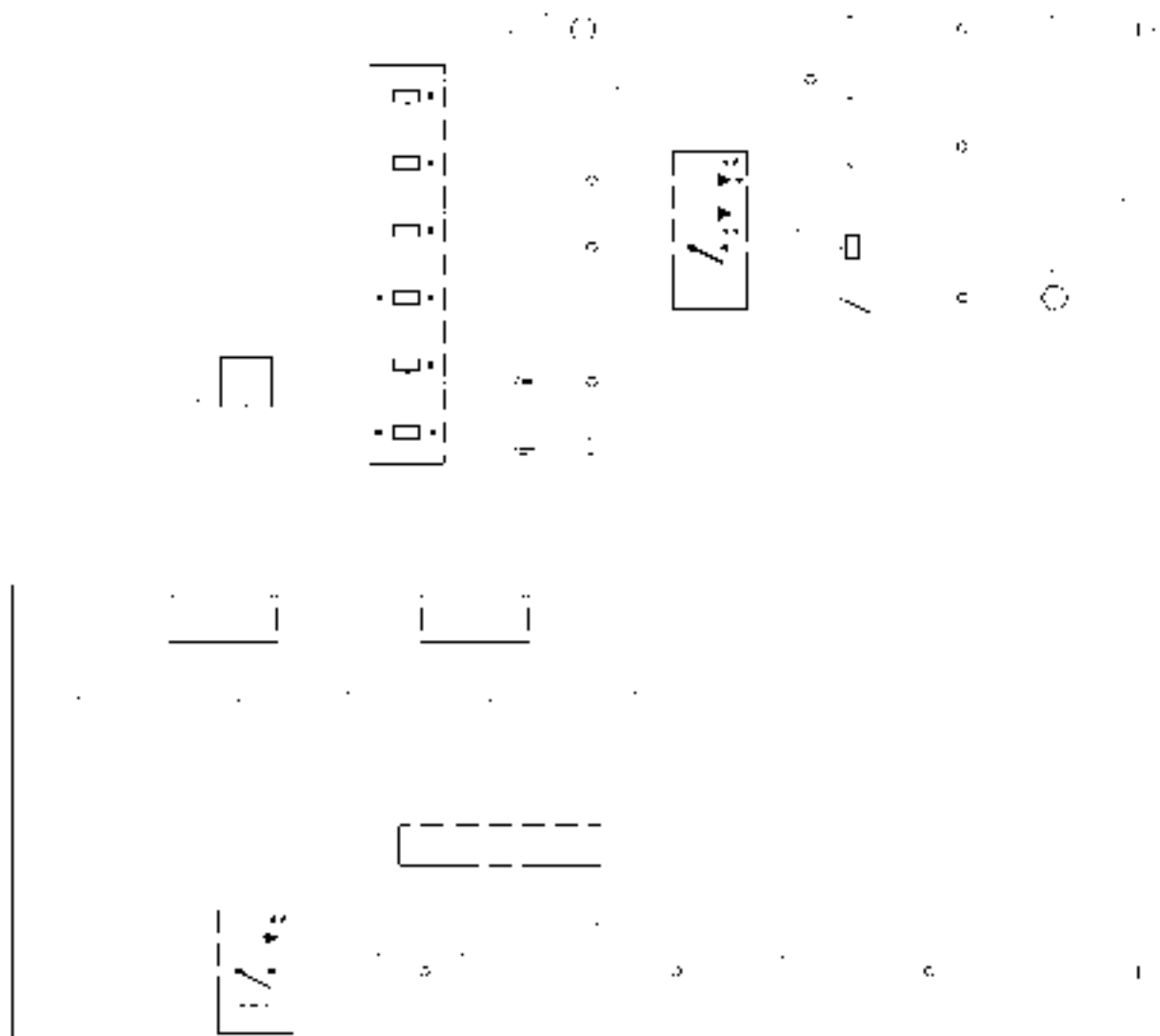

T3010028

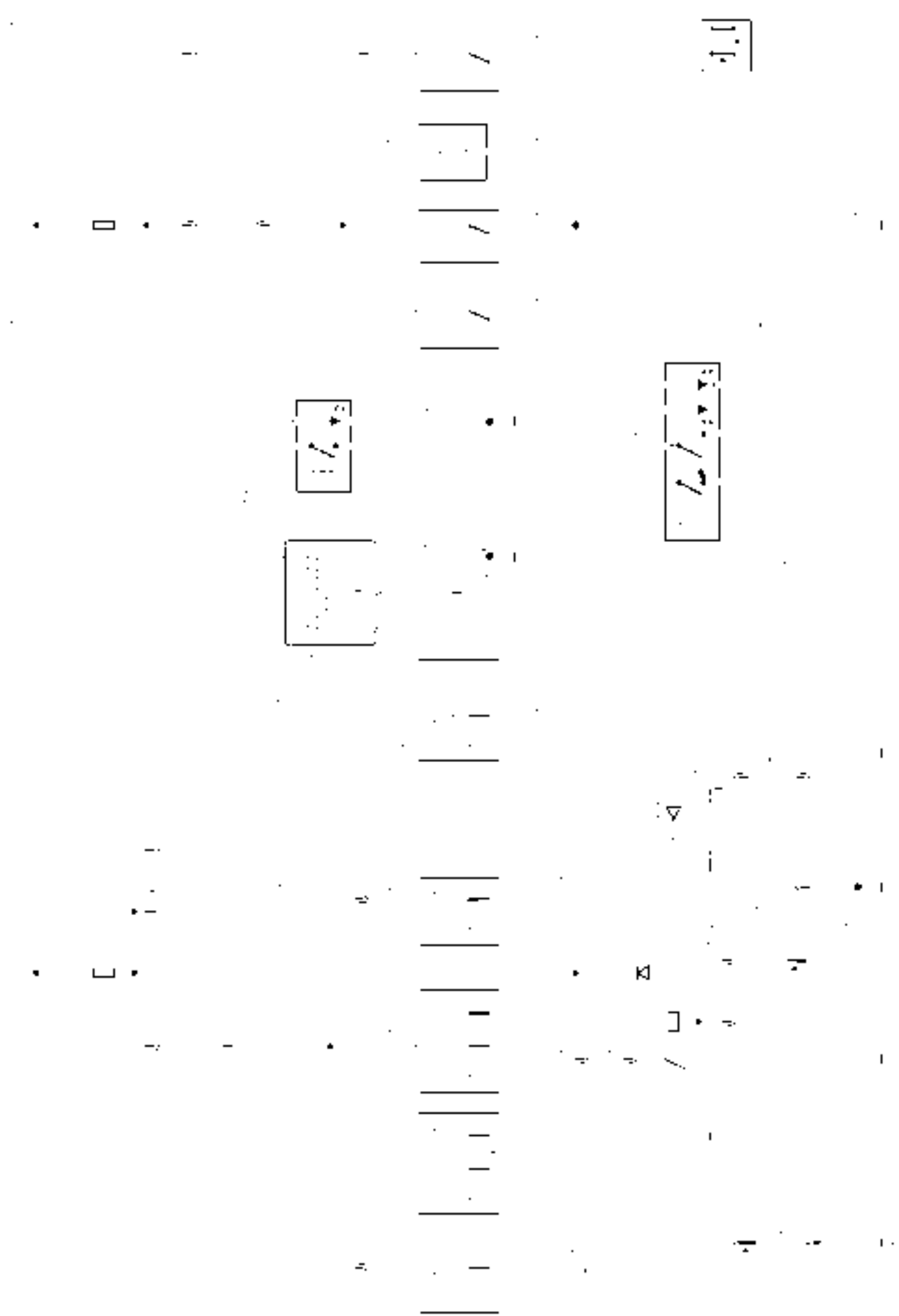

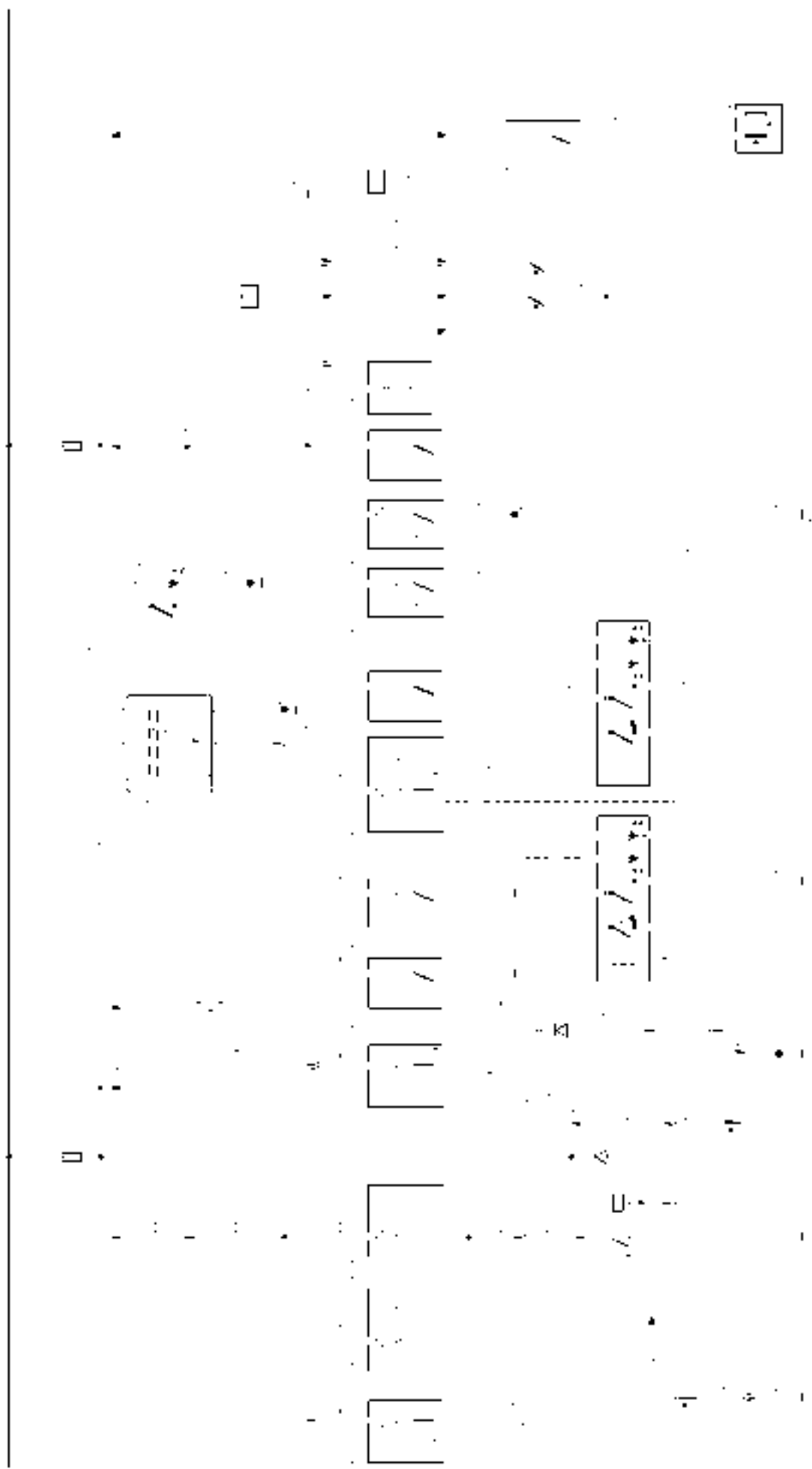

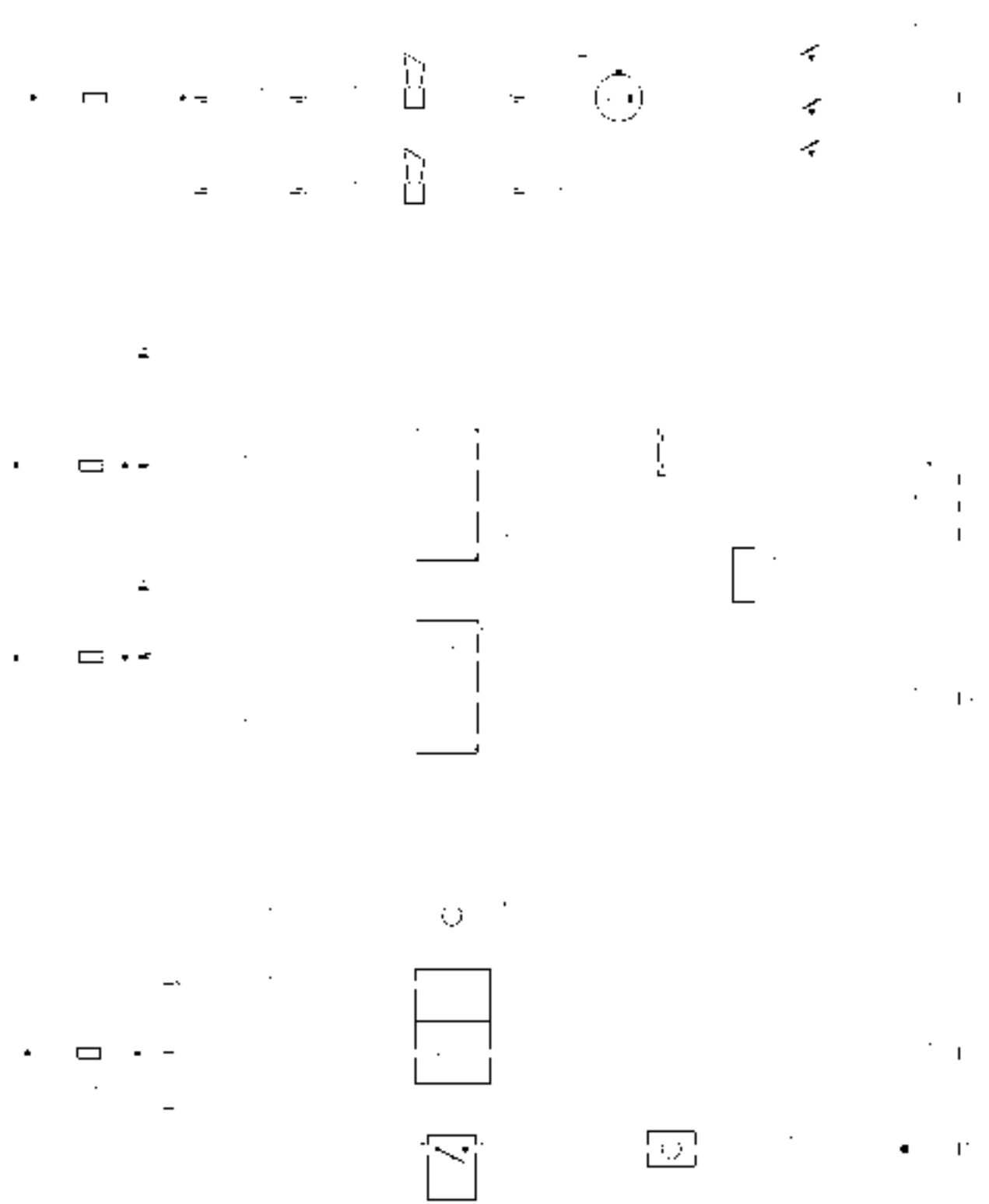

T3010031



T3010032

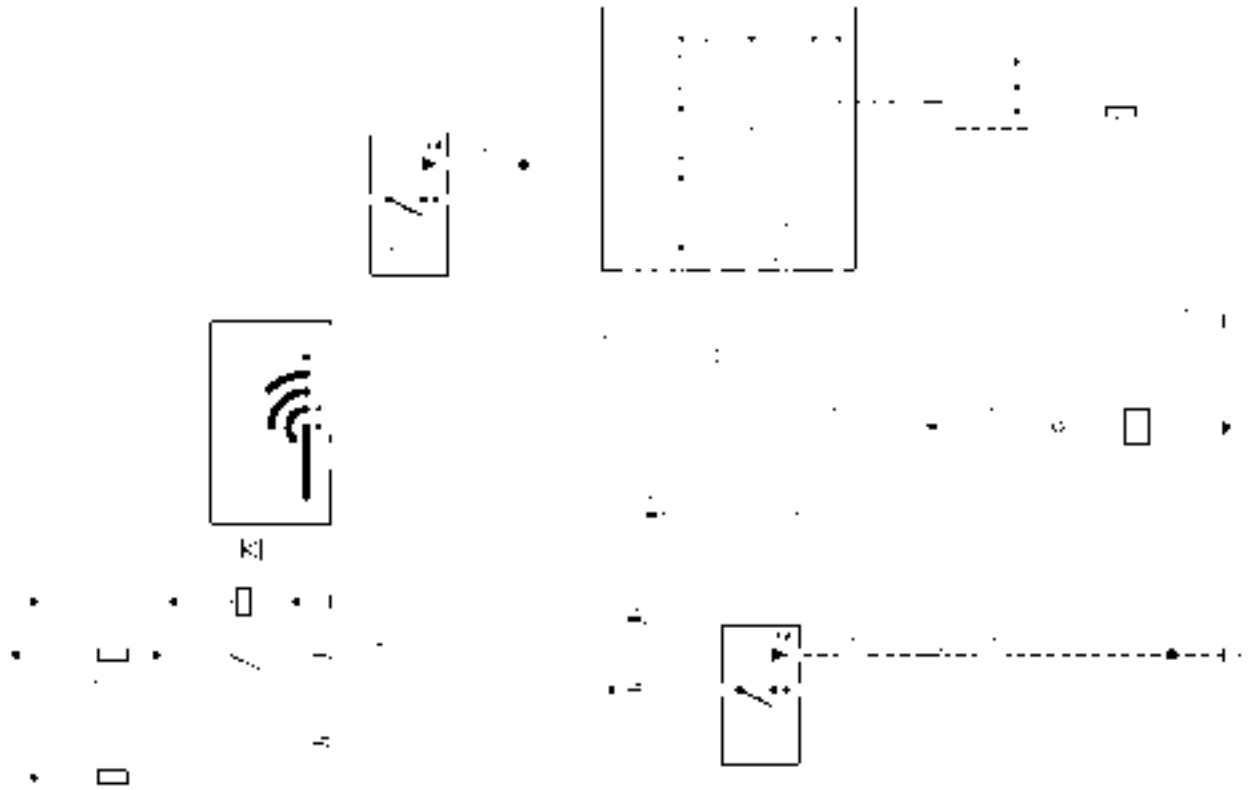

T3010033

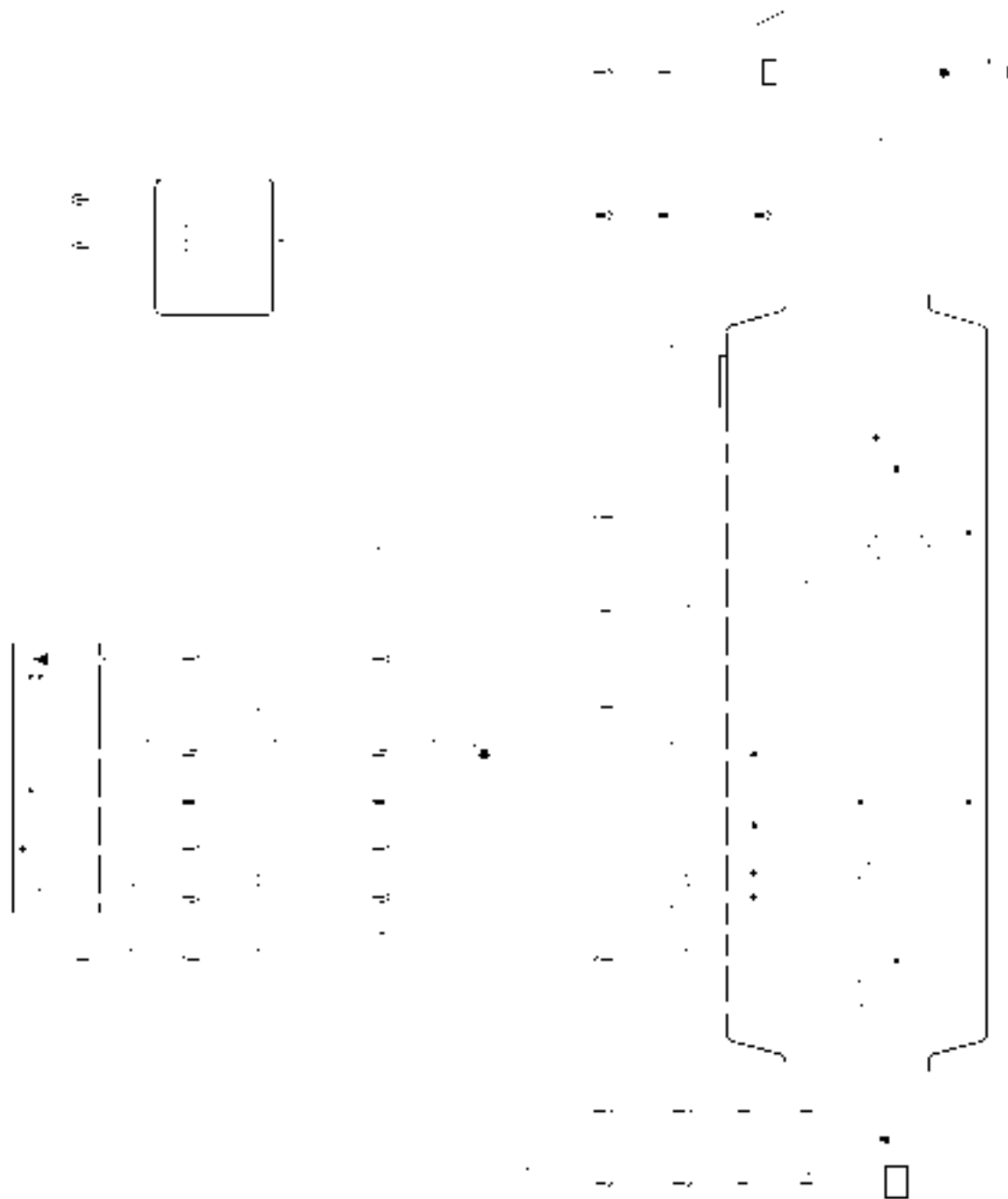

T3010034



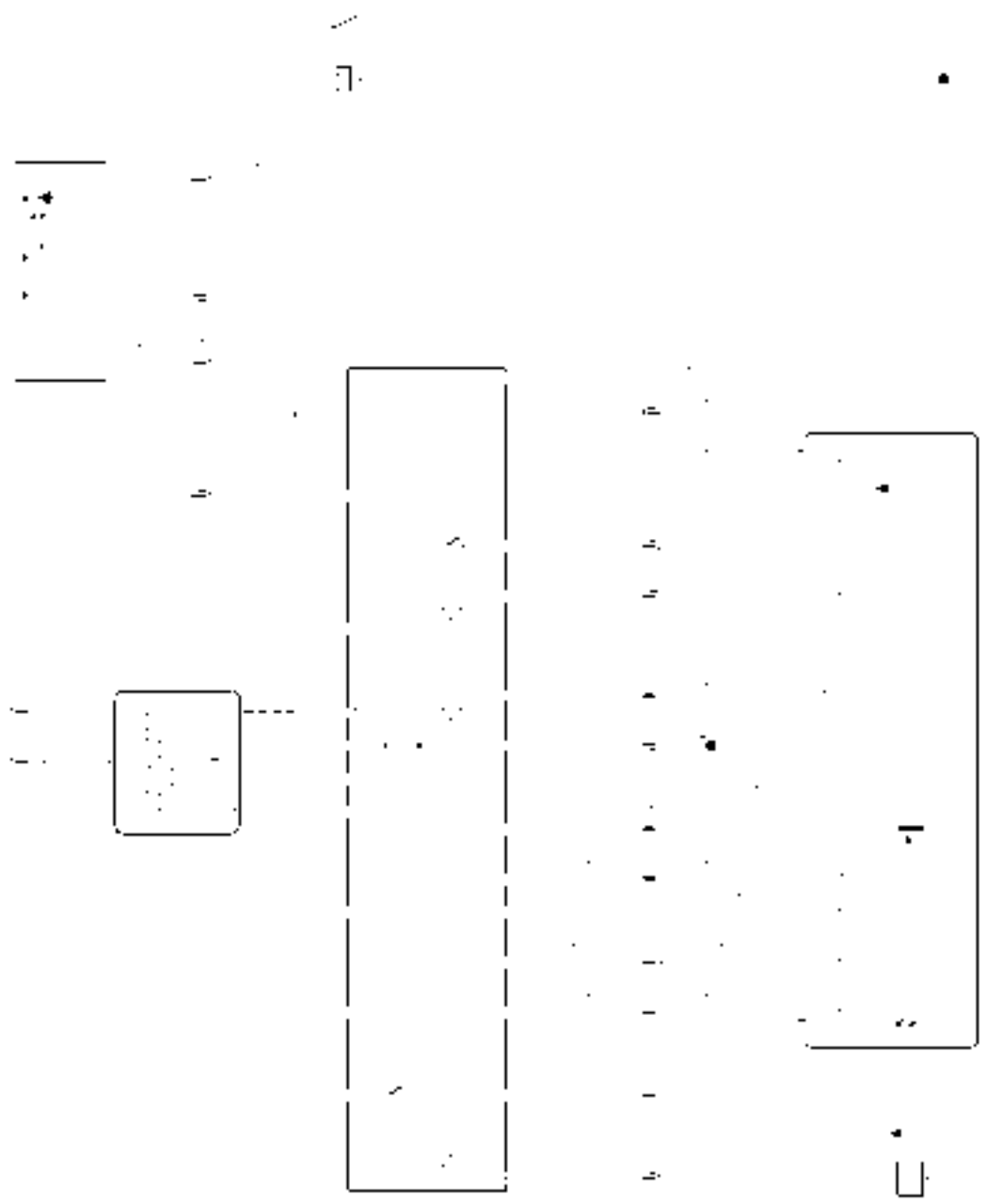

T3010035

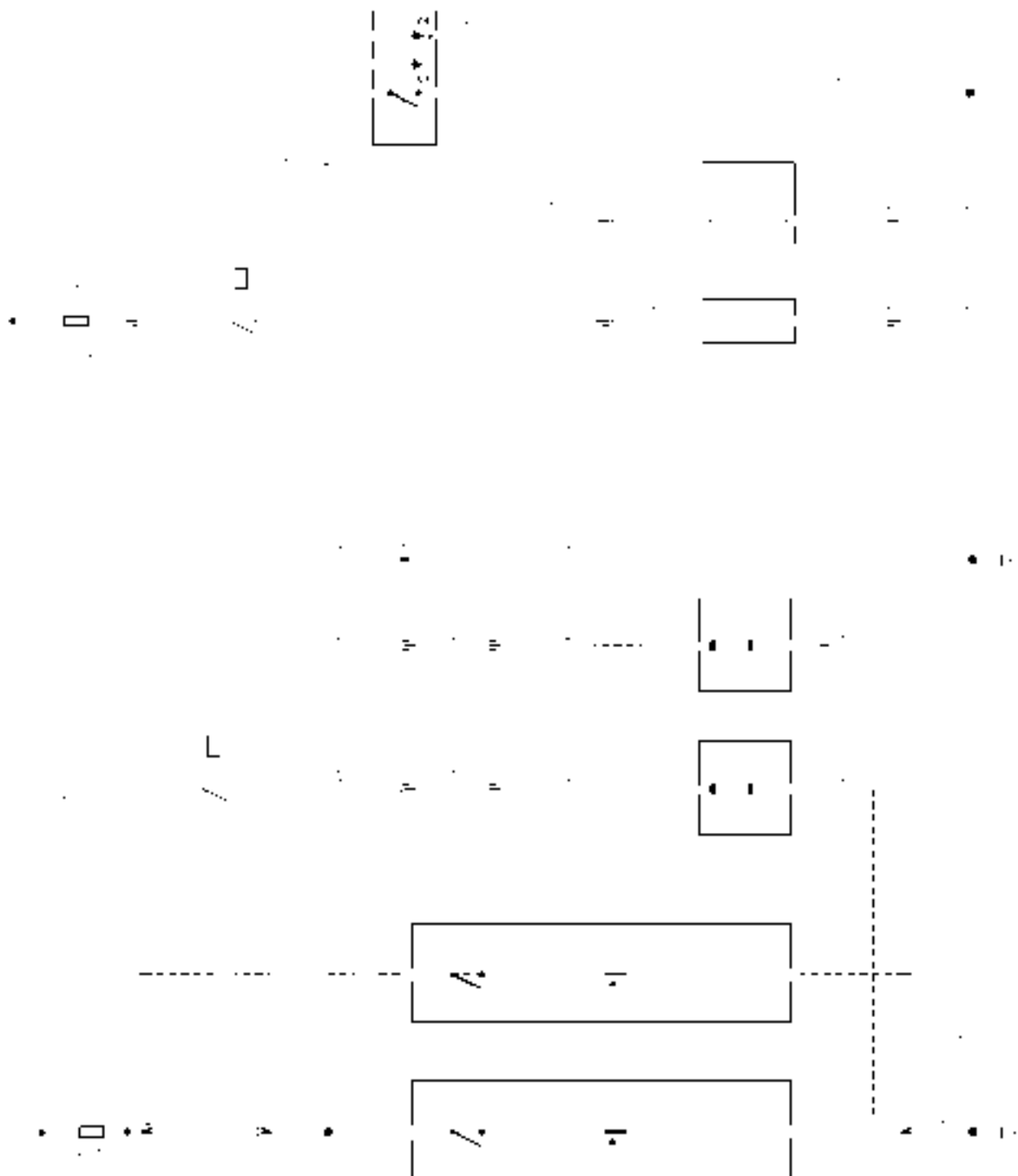

T3010036

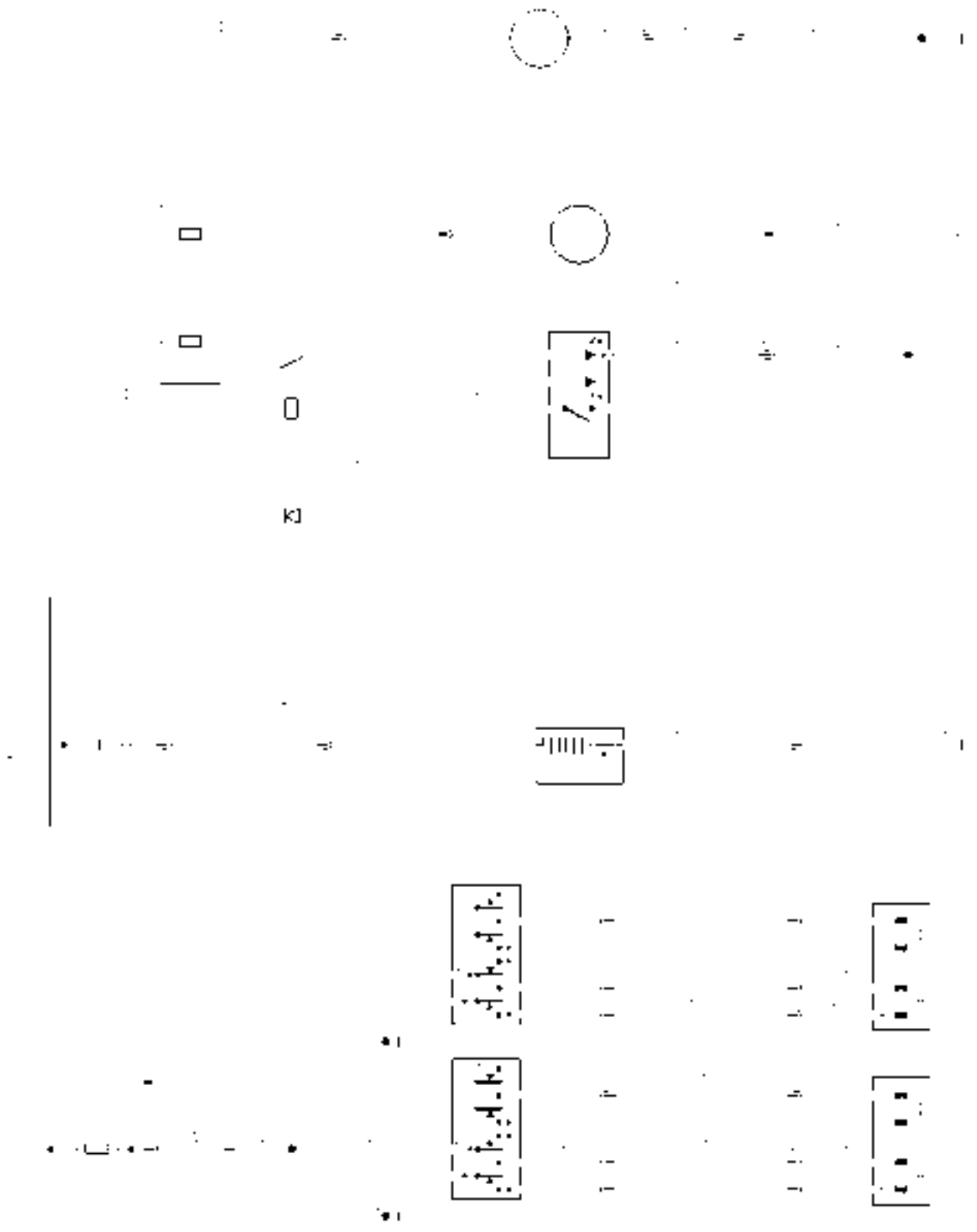

T3010037

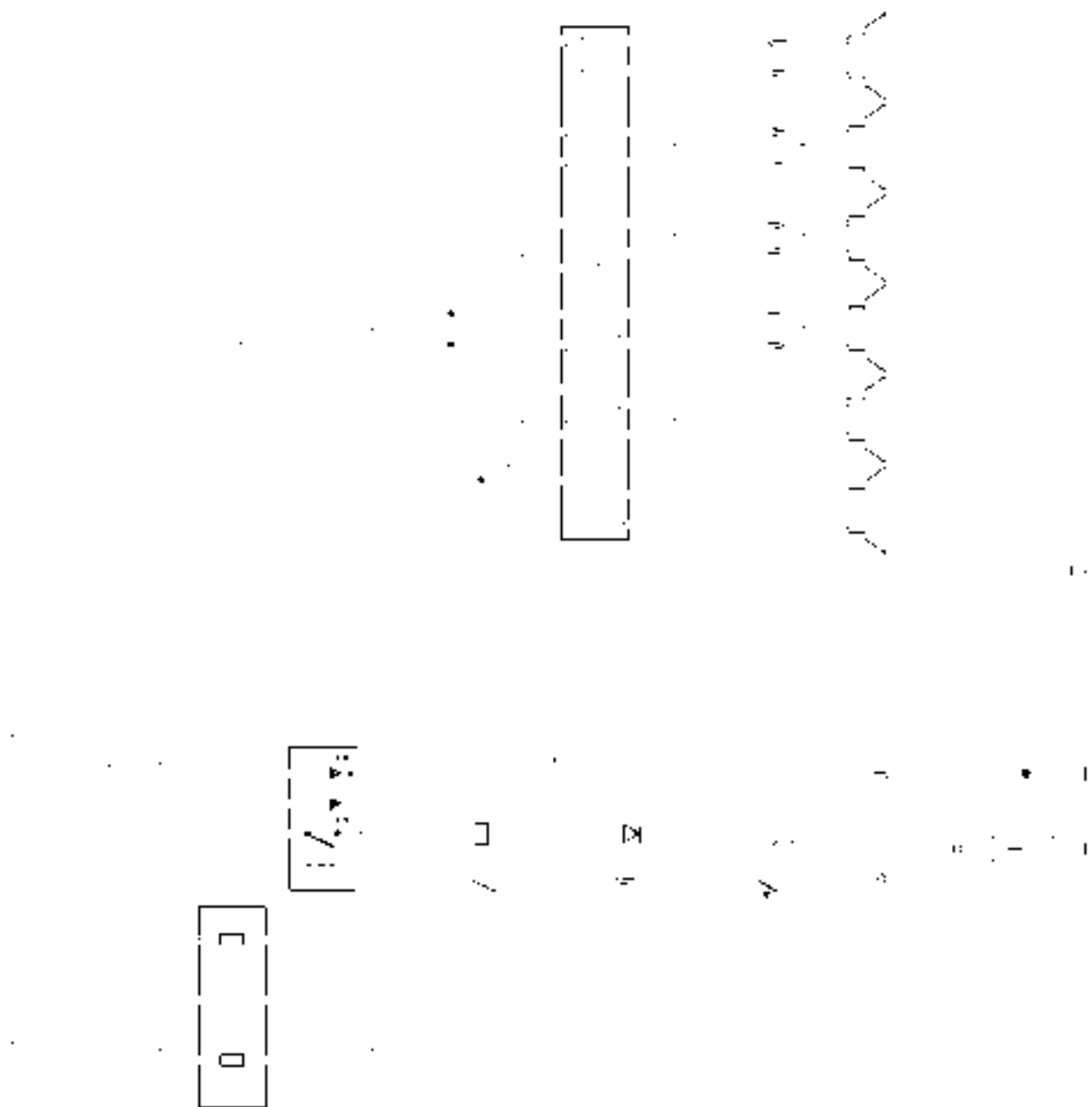

T3010038

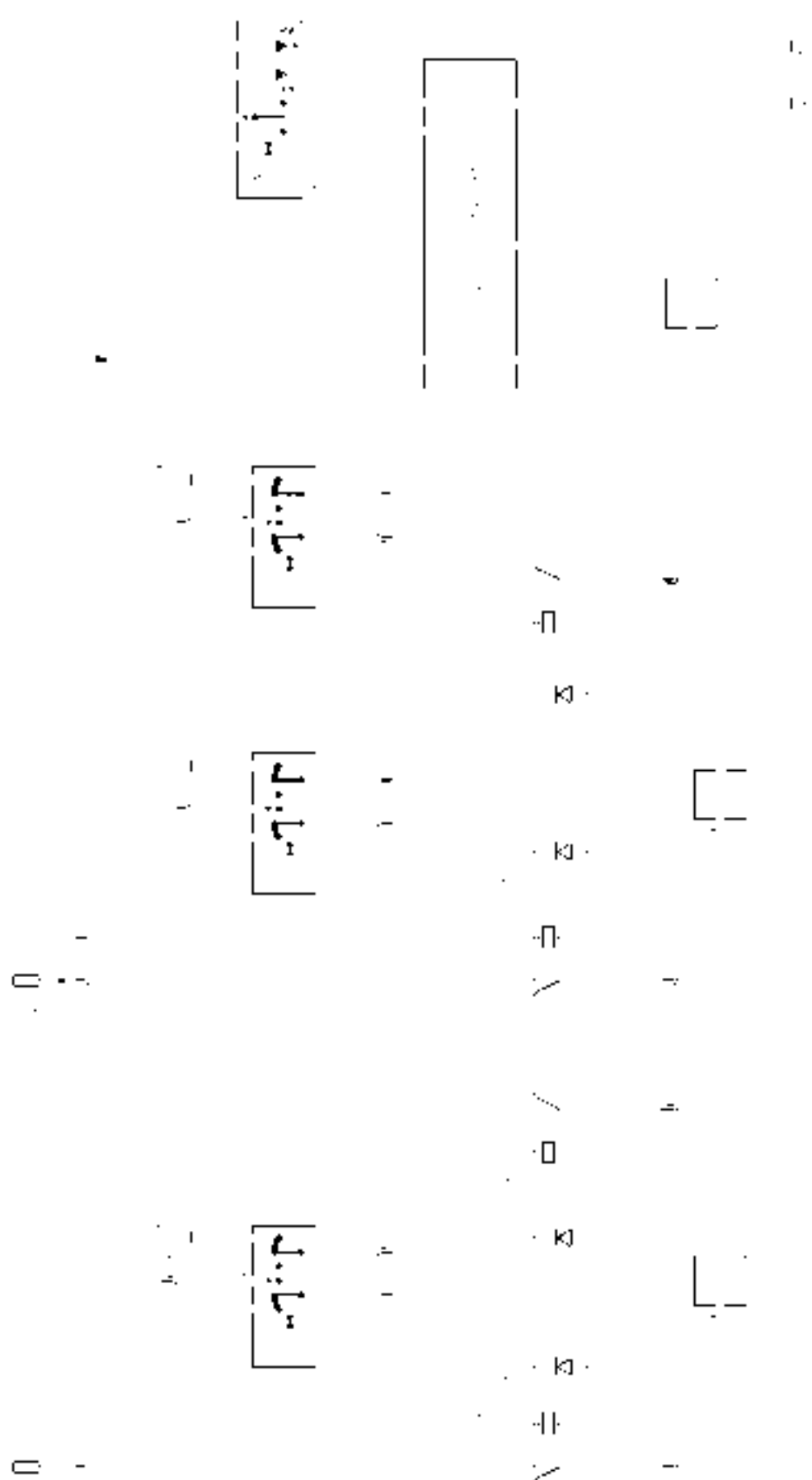

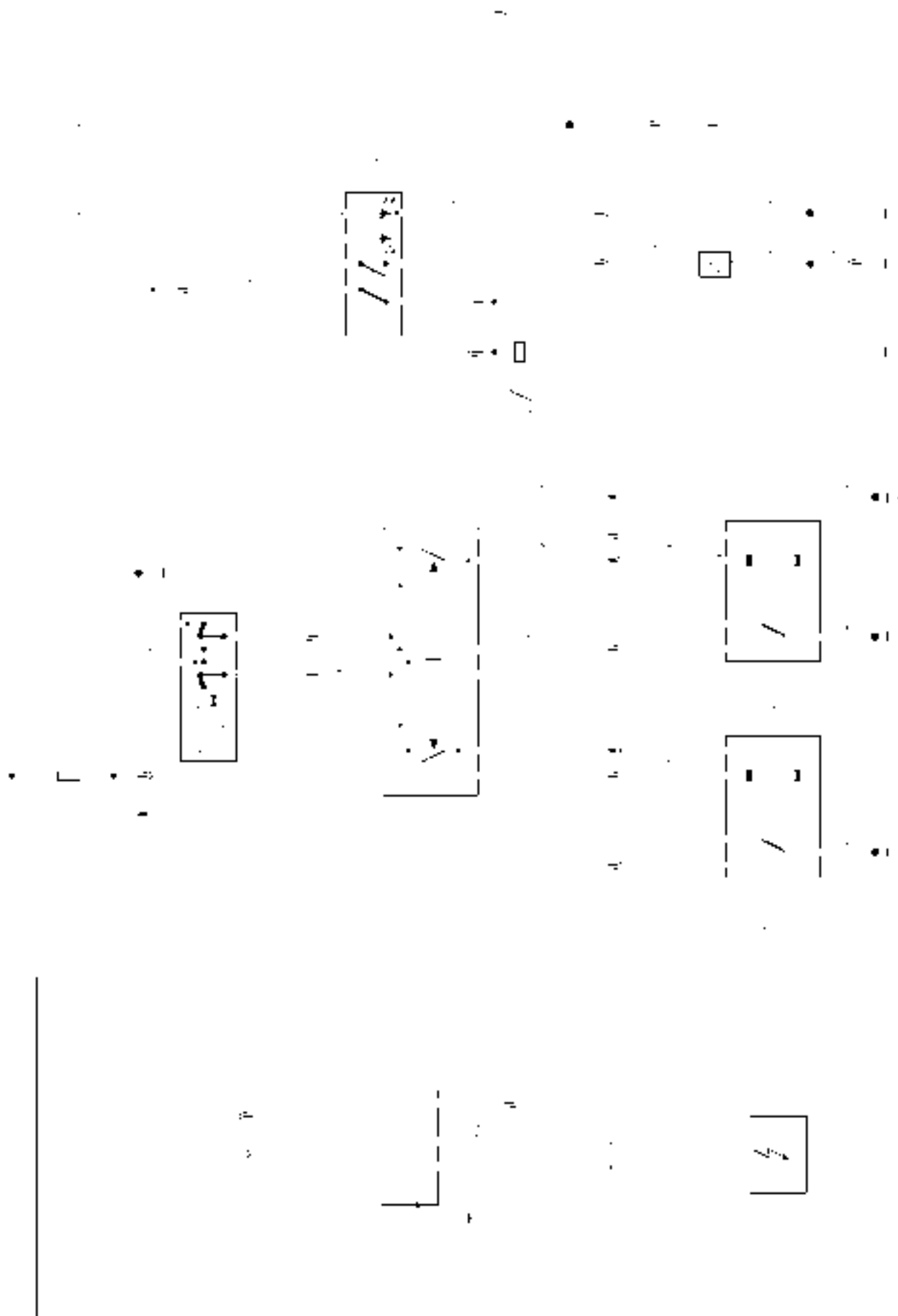



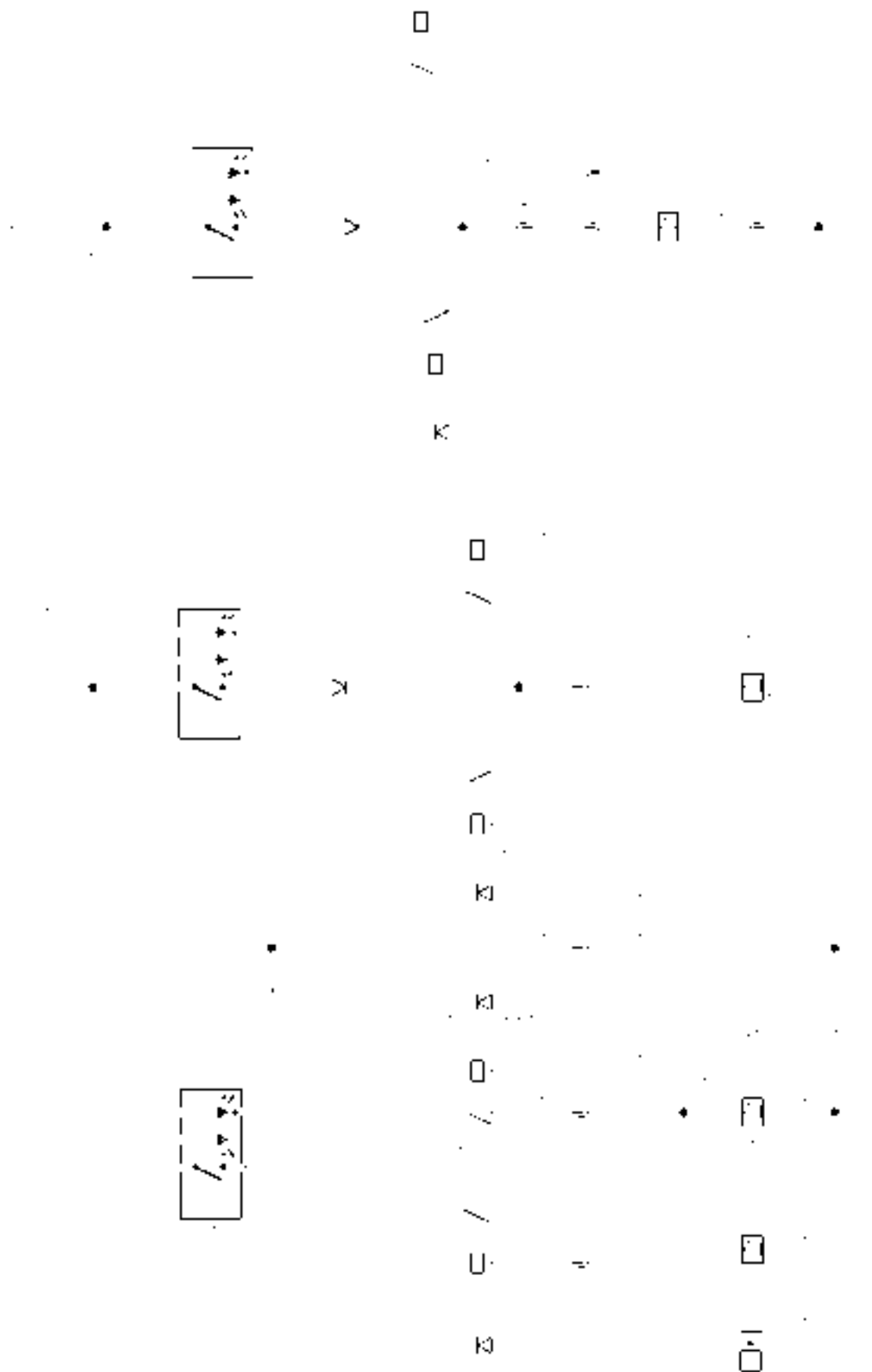



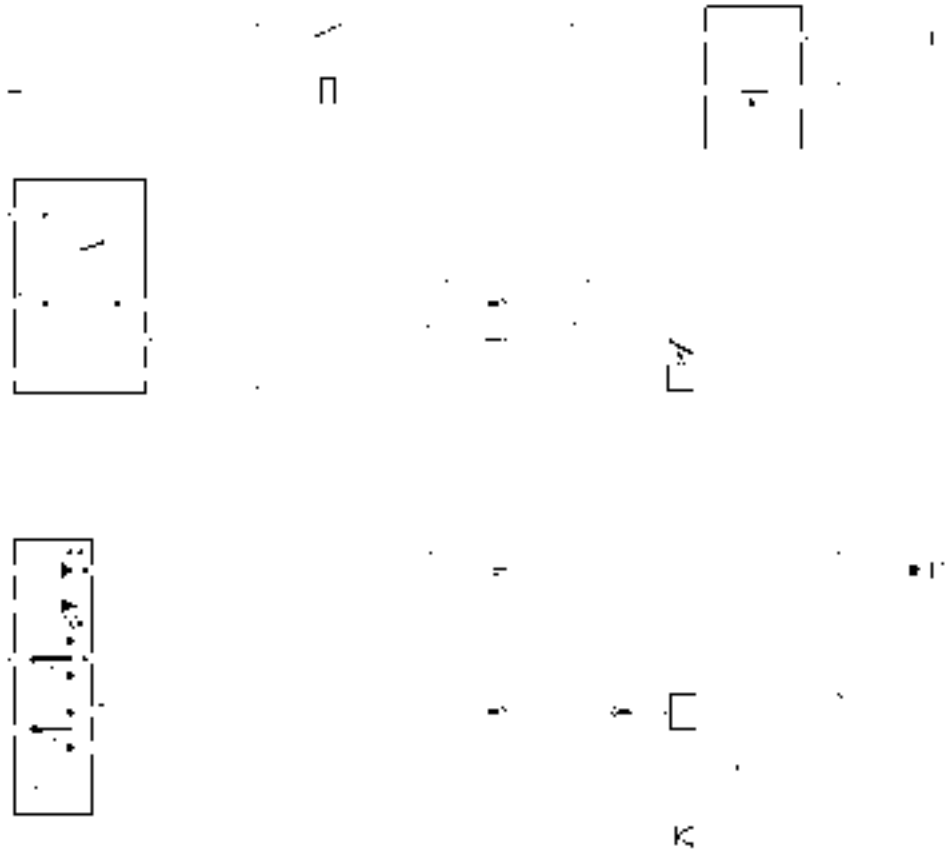

T3010045

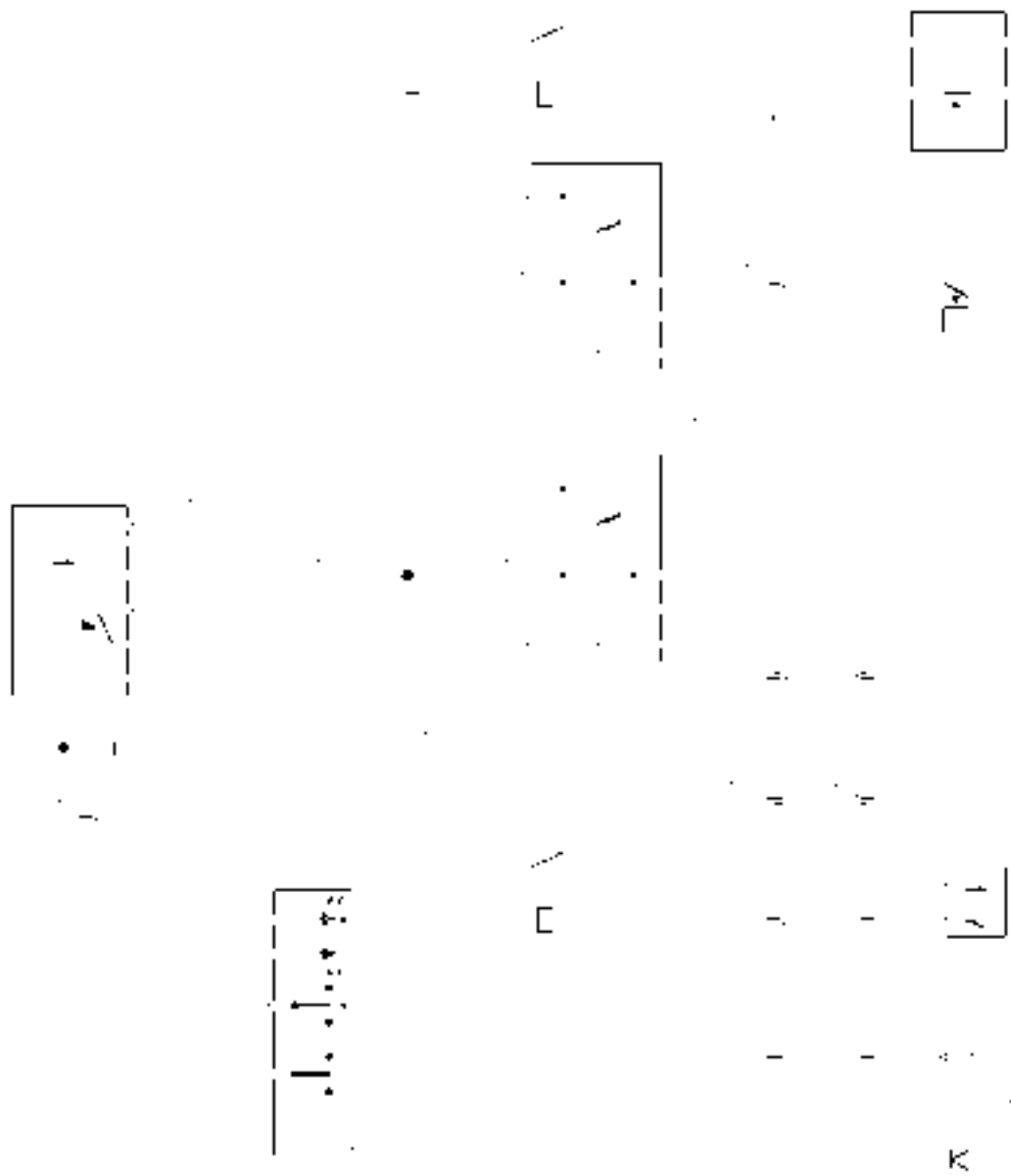

T3010046

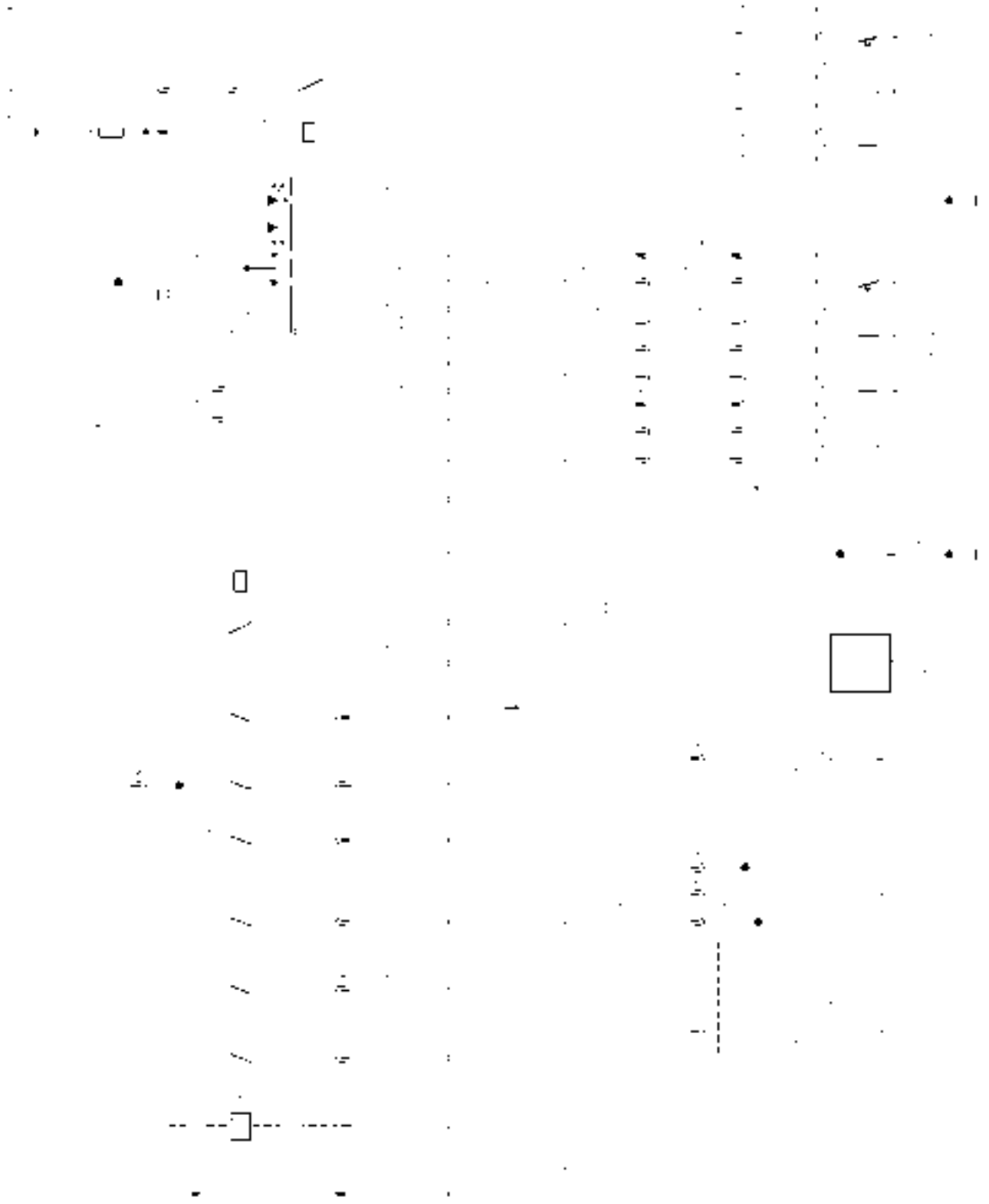

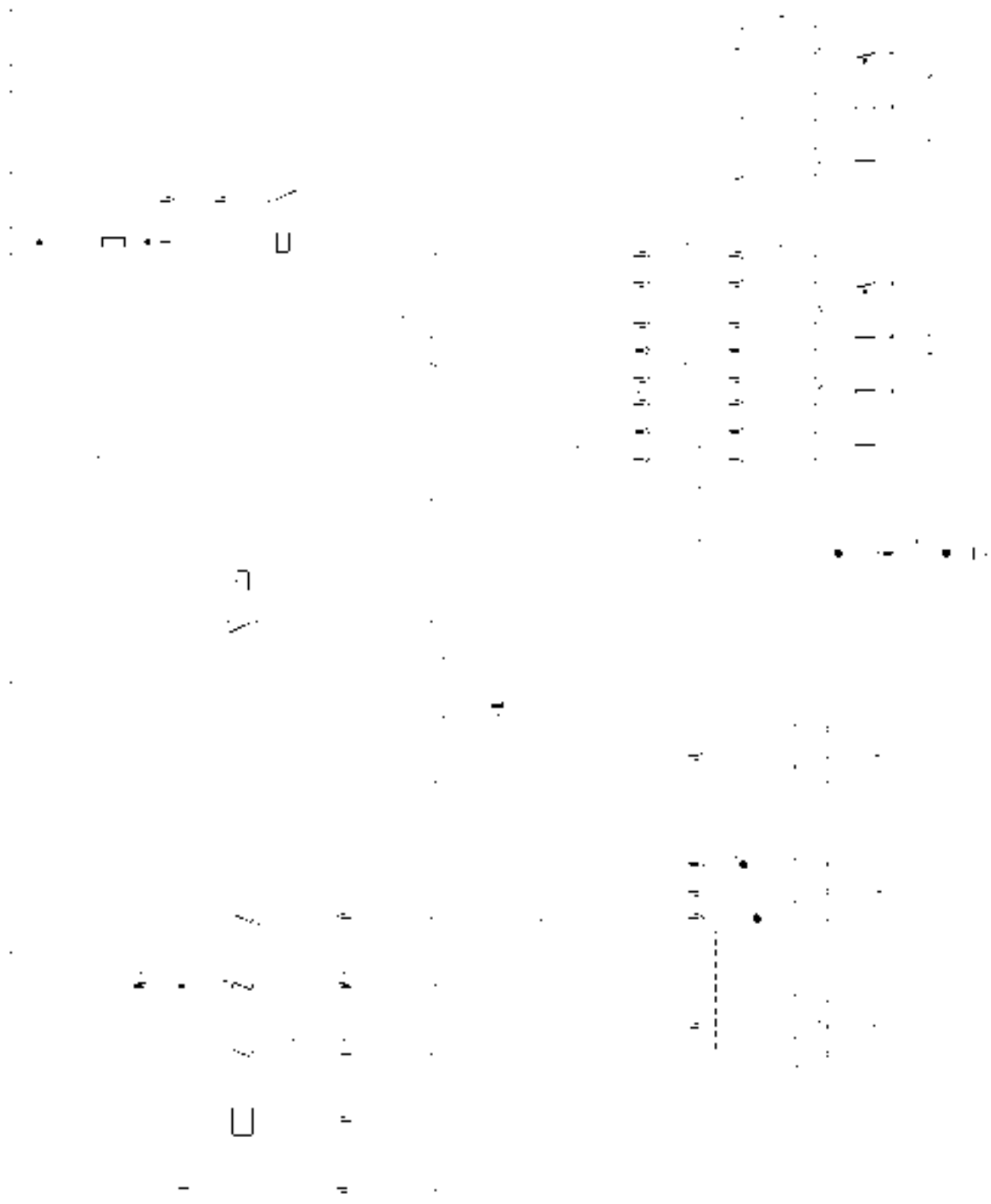

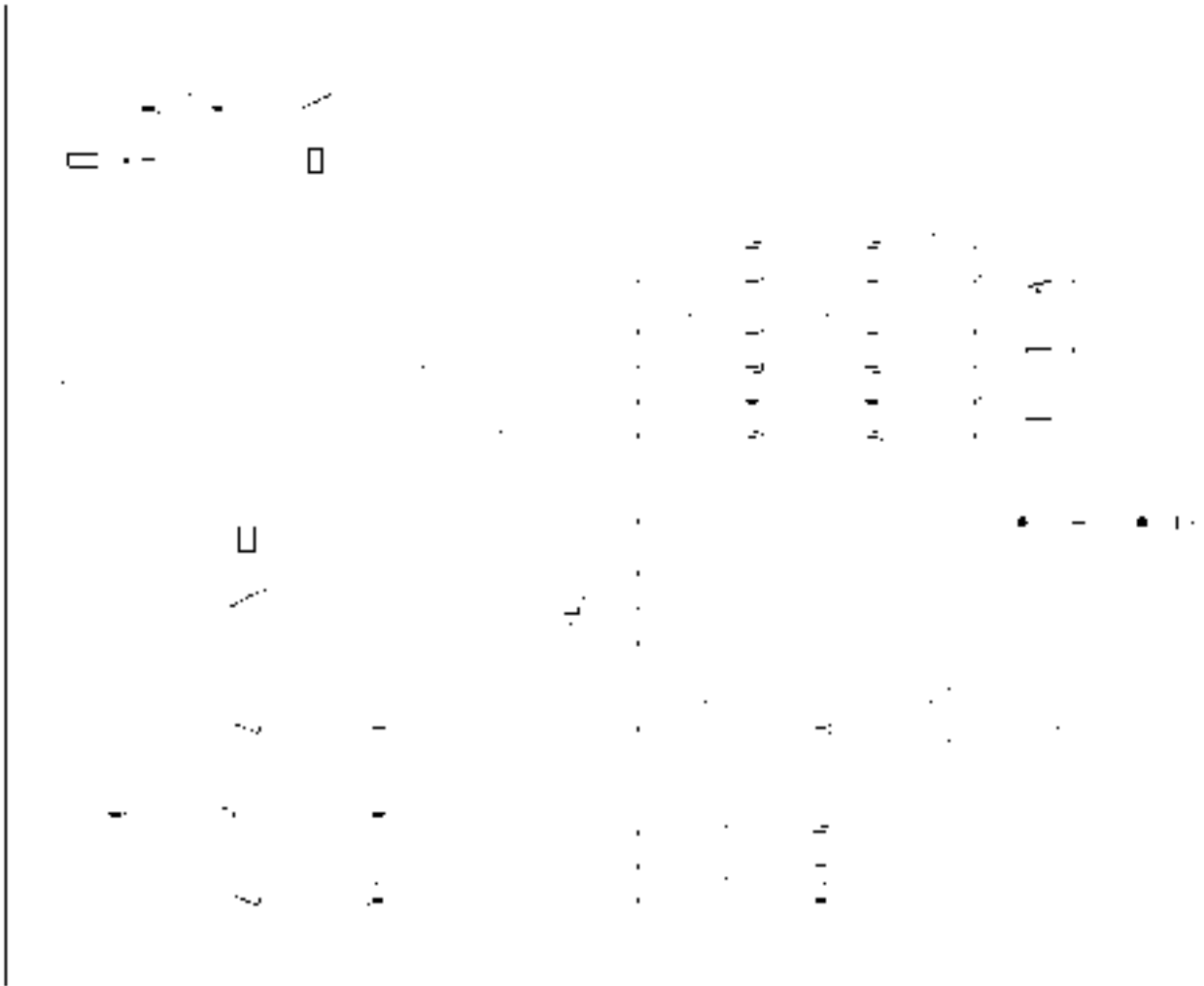

T3010049

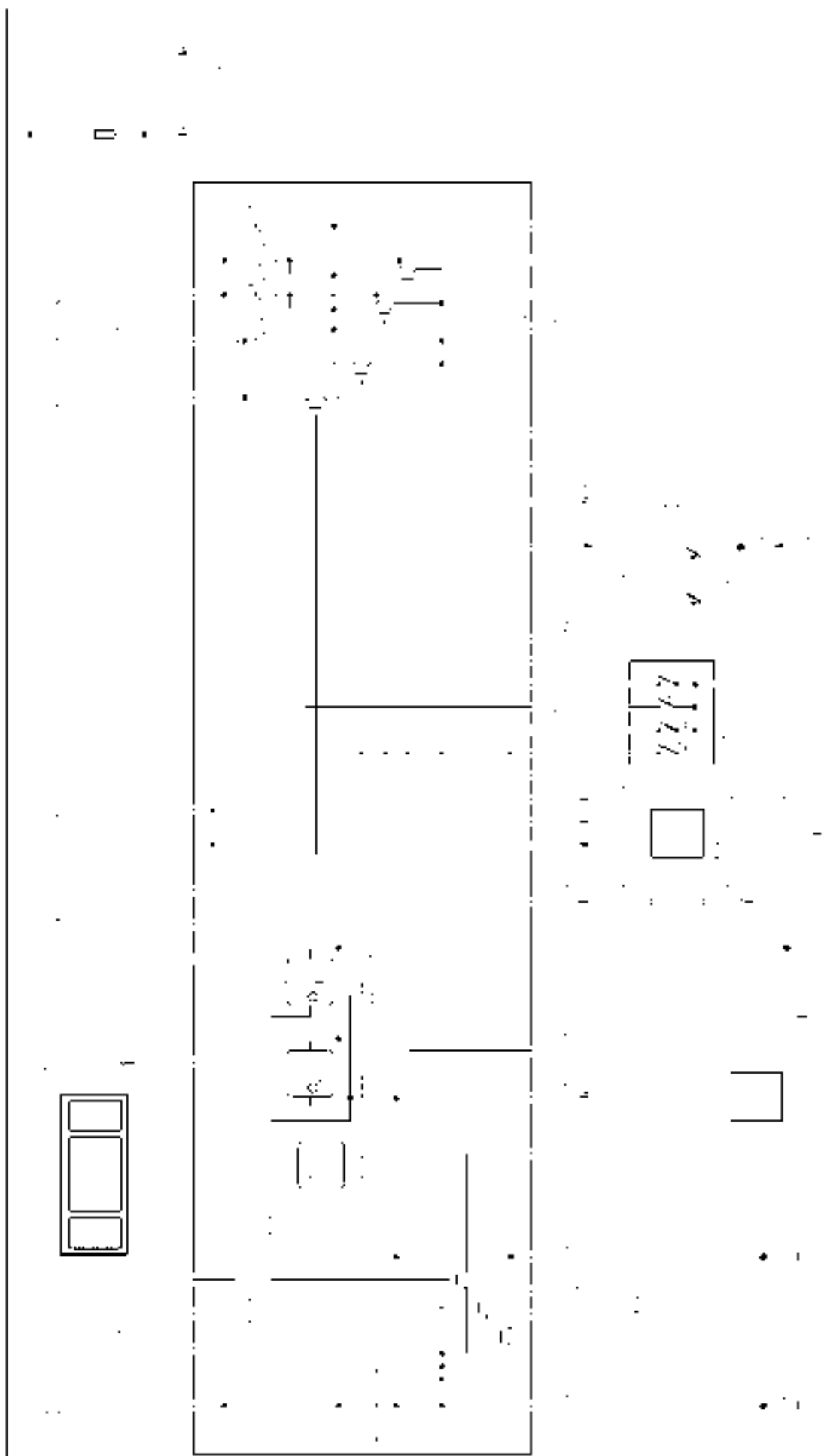

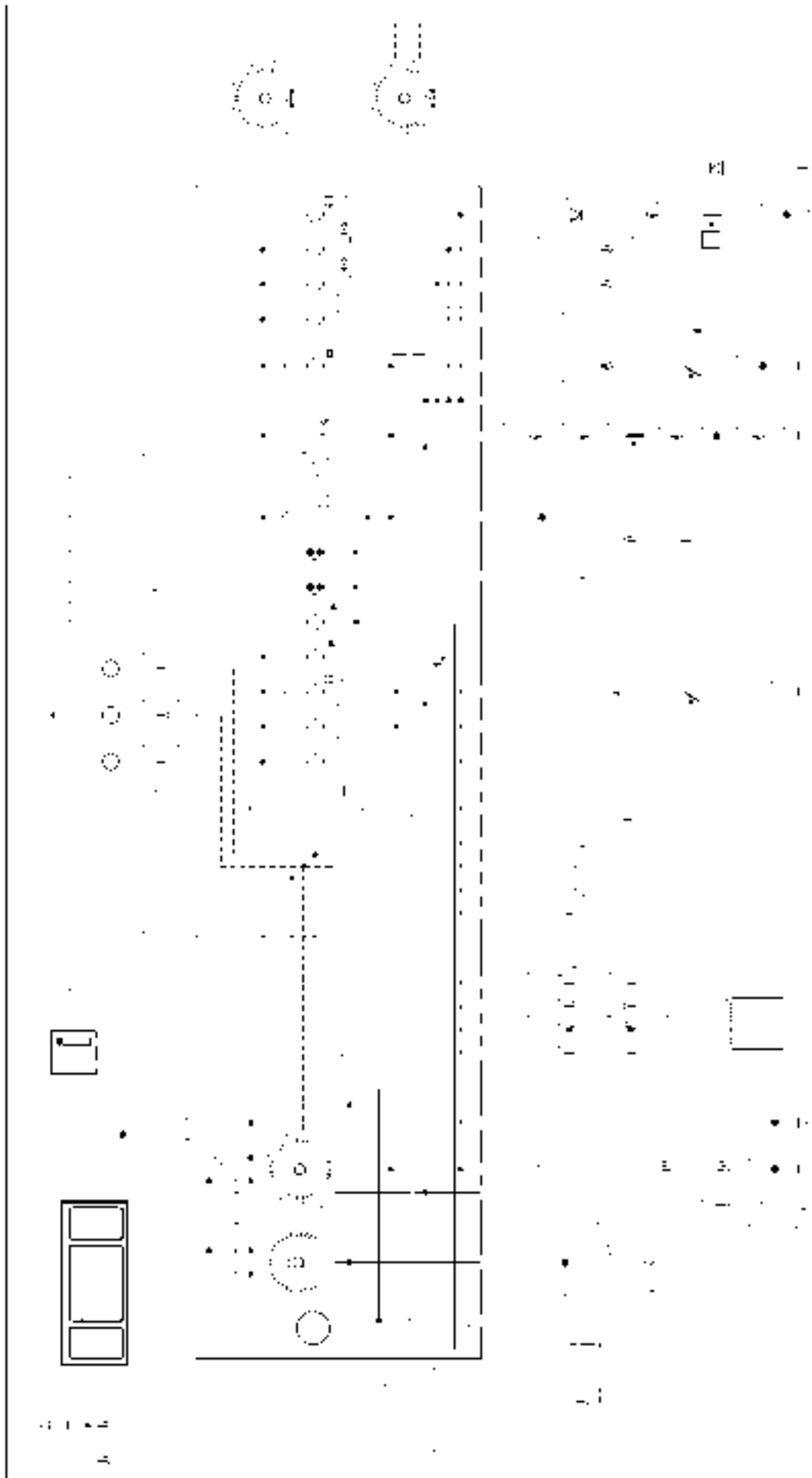

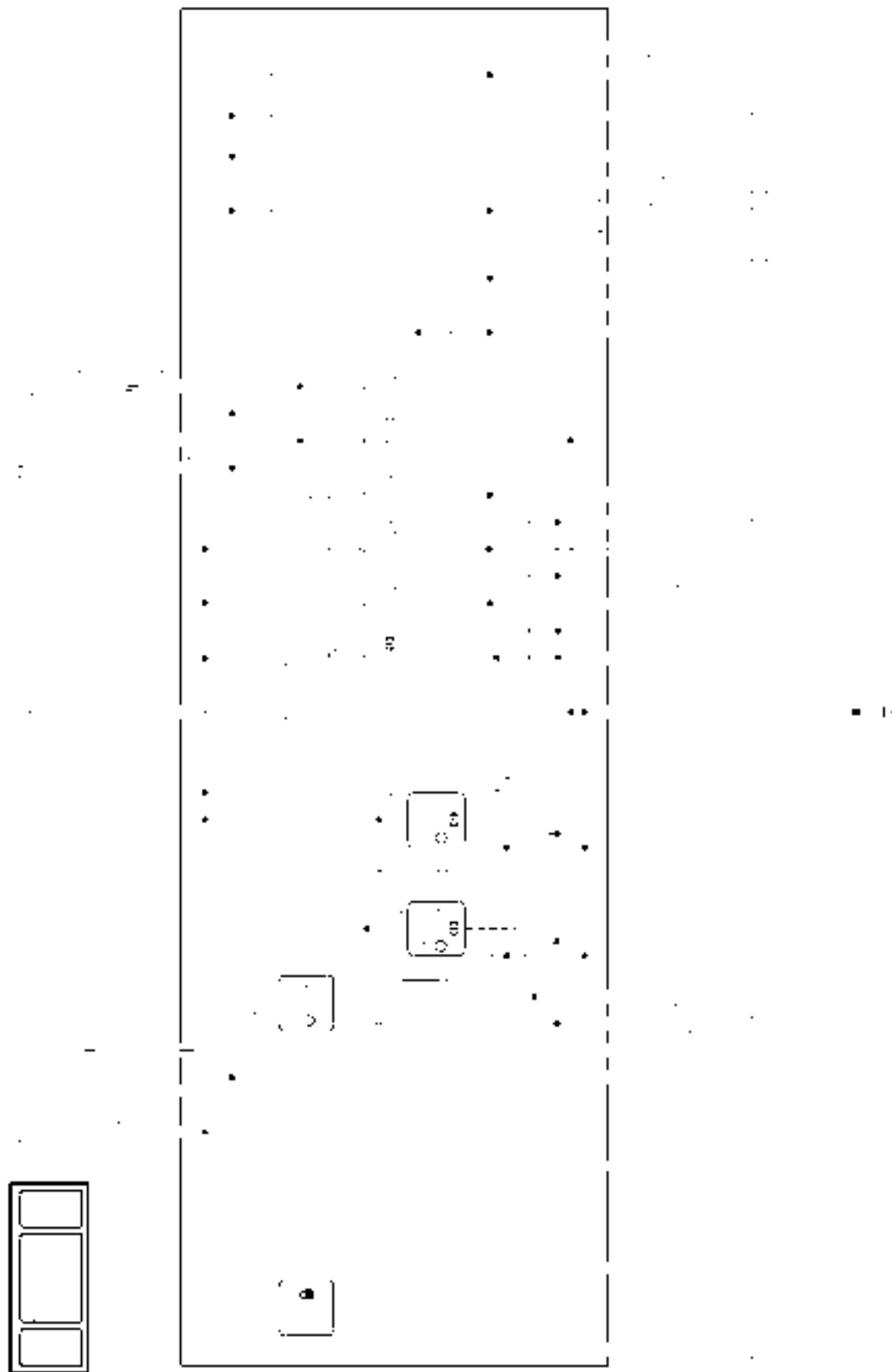



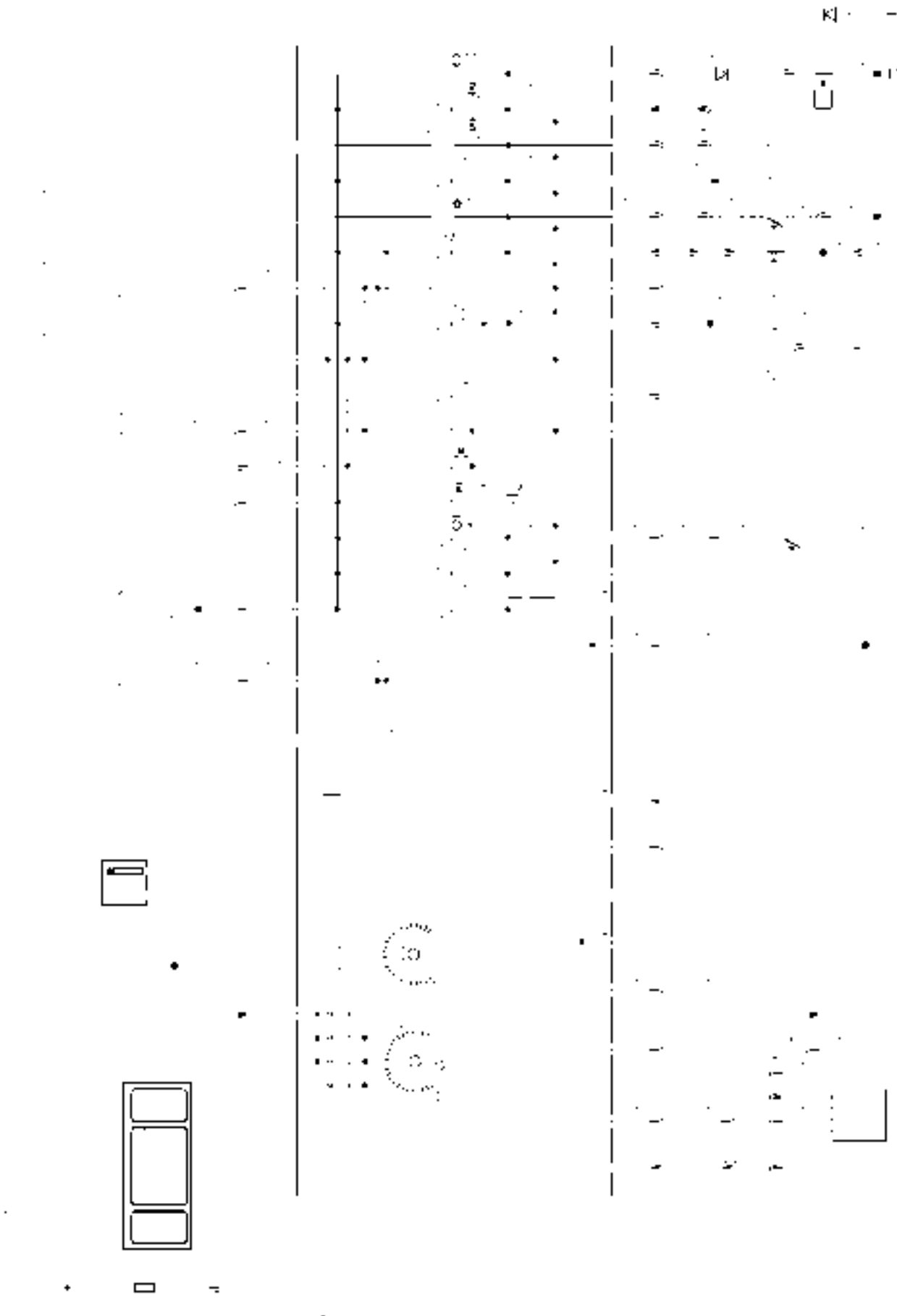

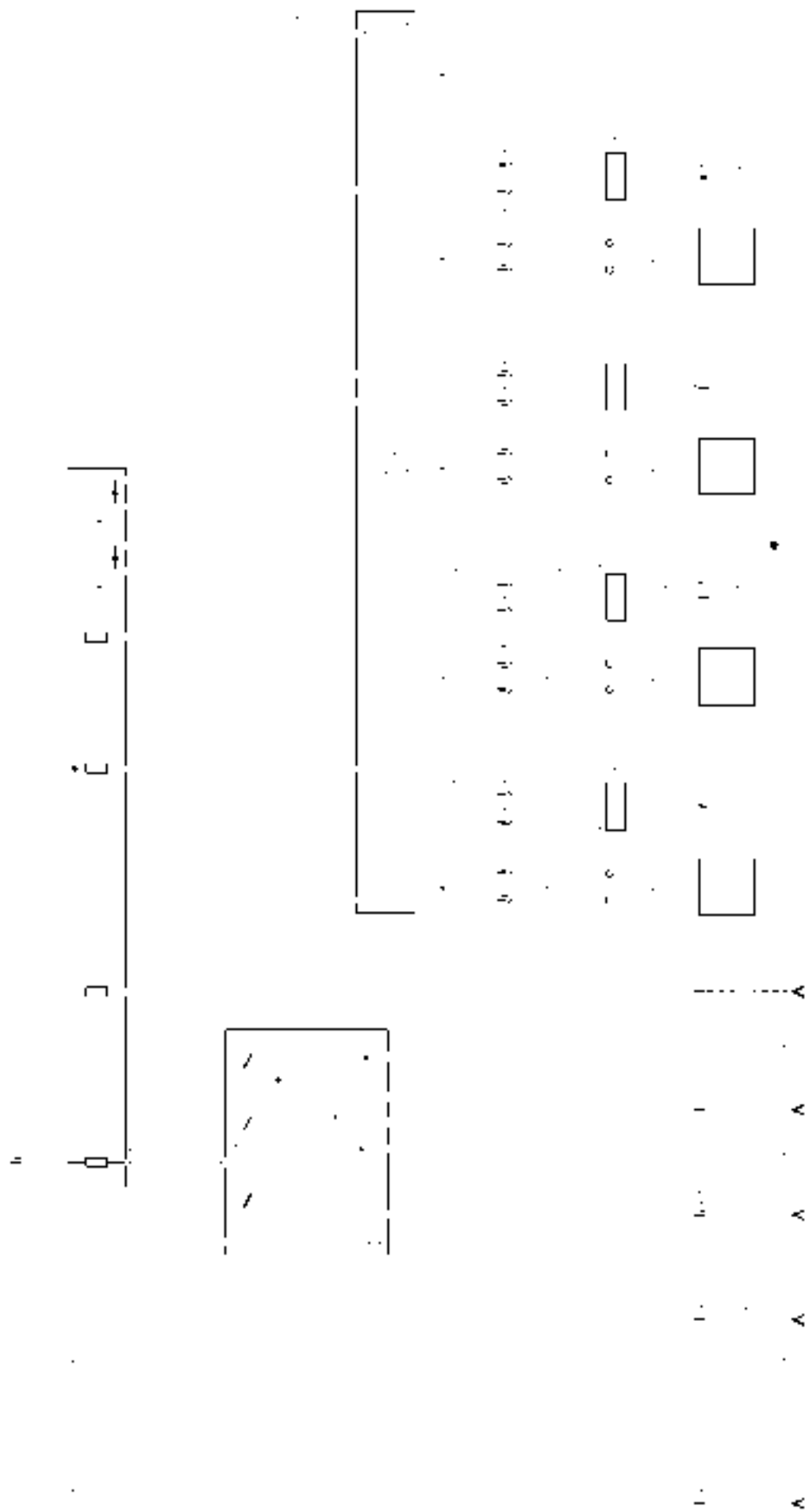

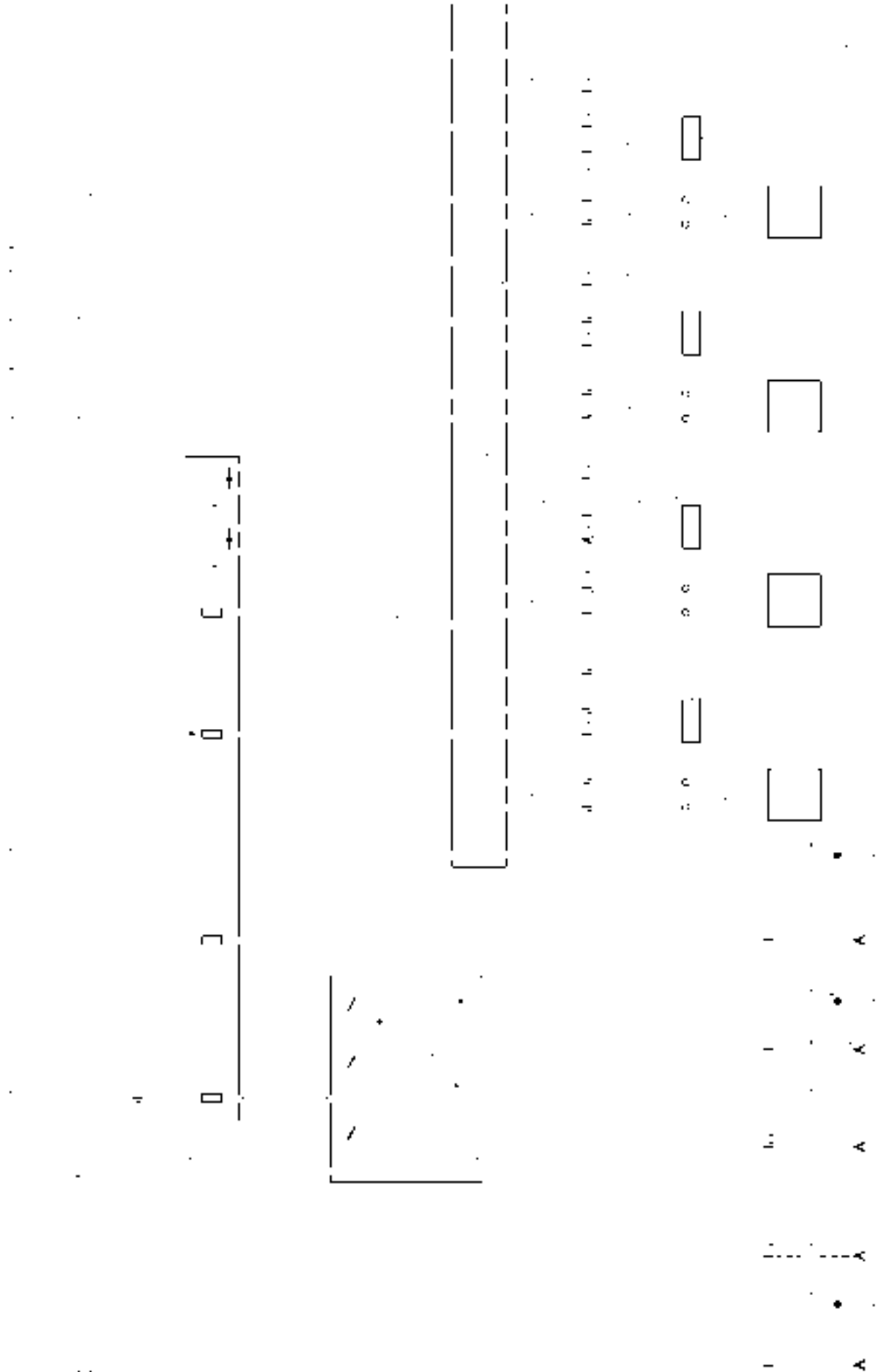

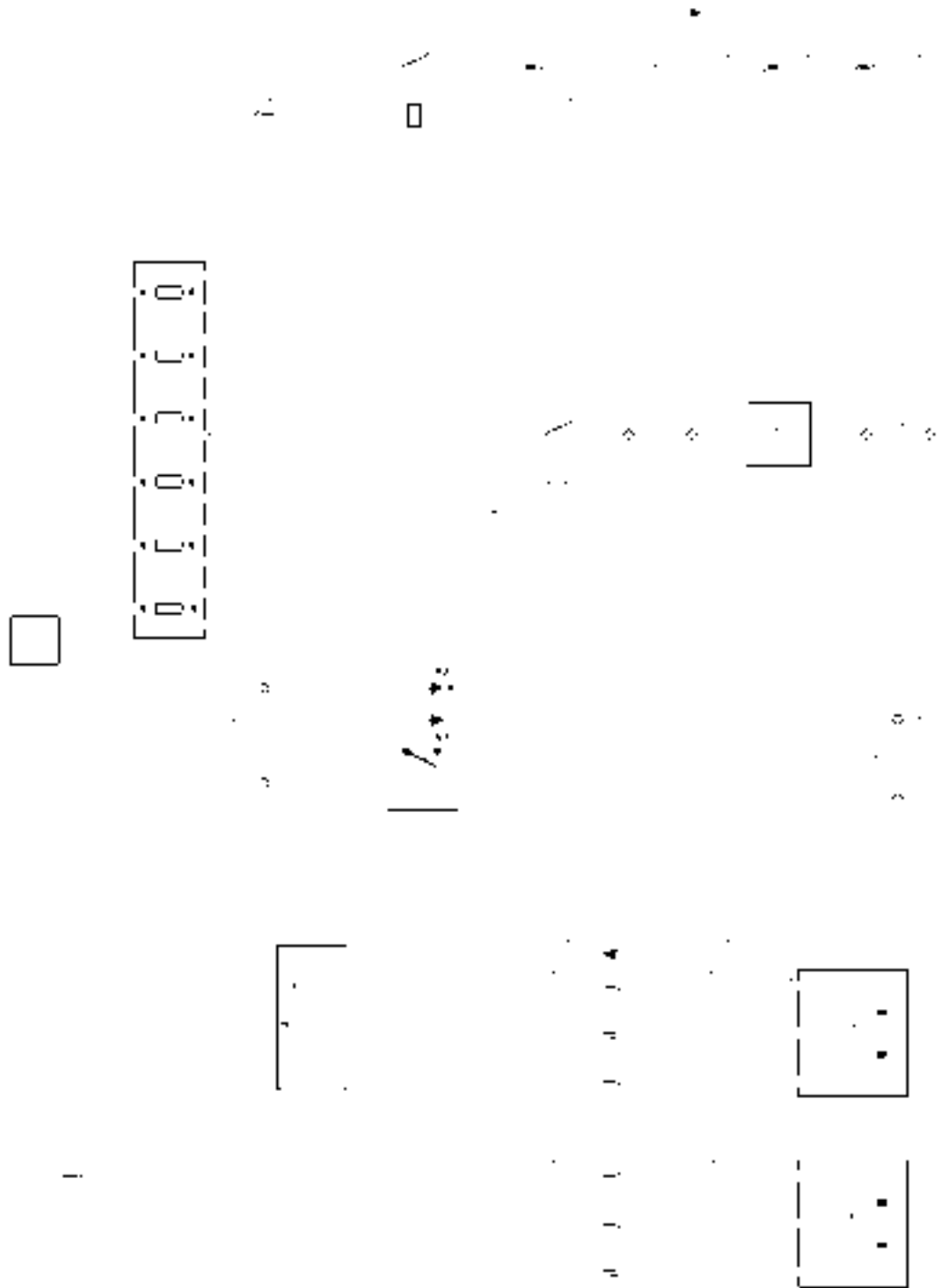

T3010057

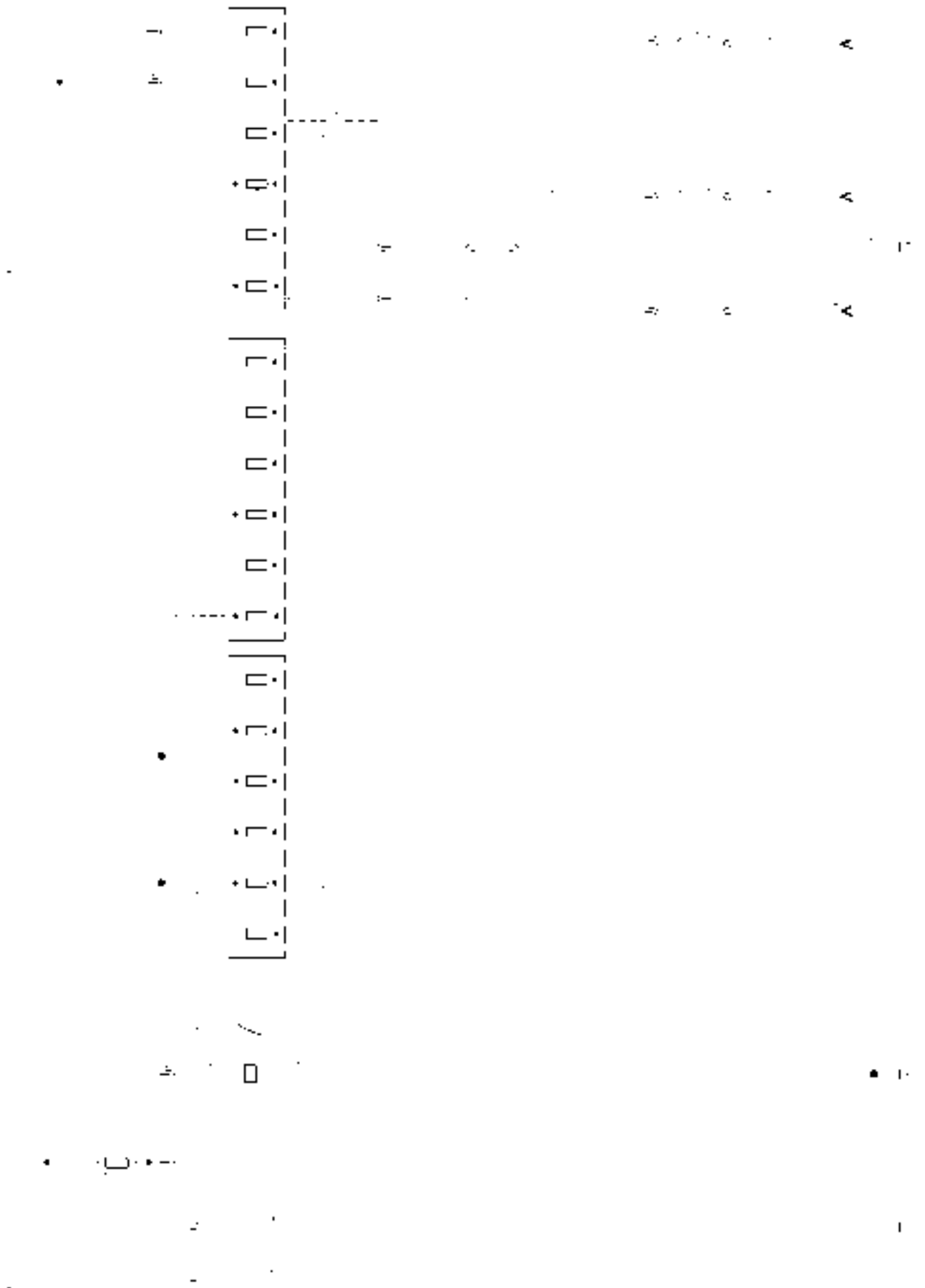

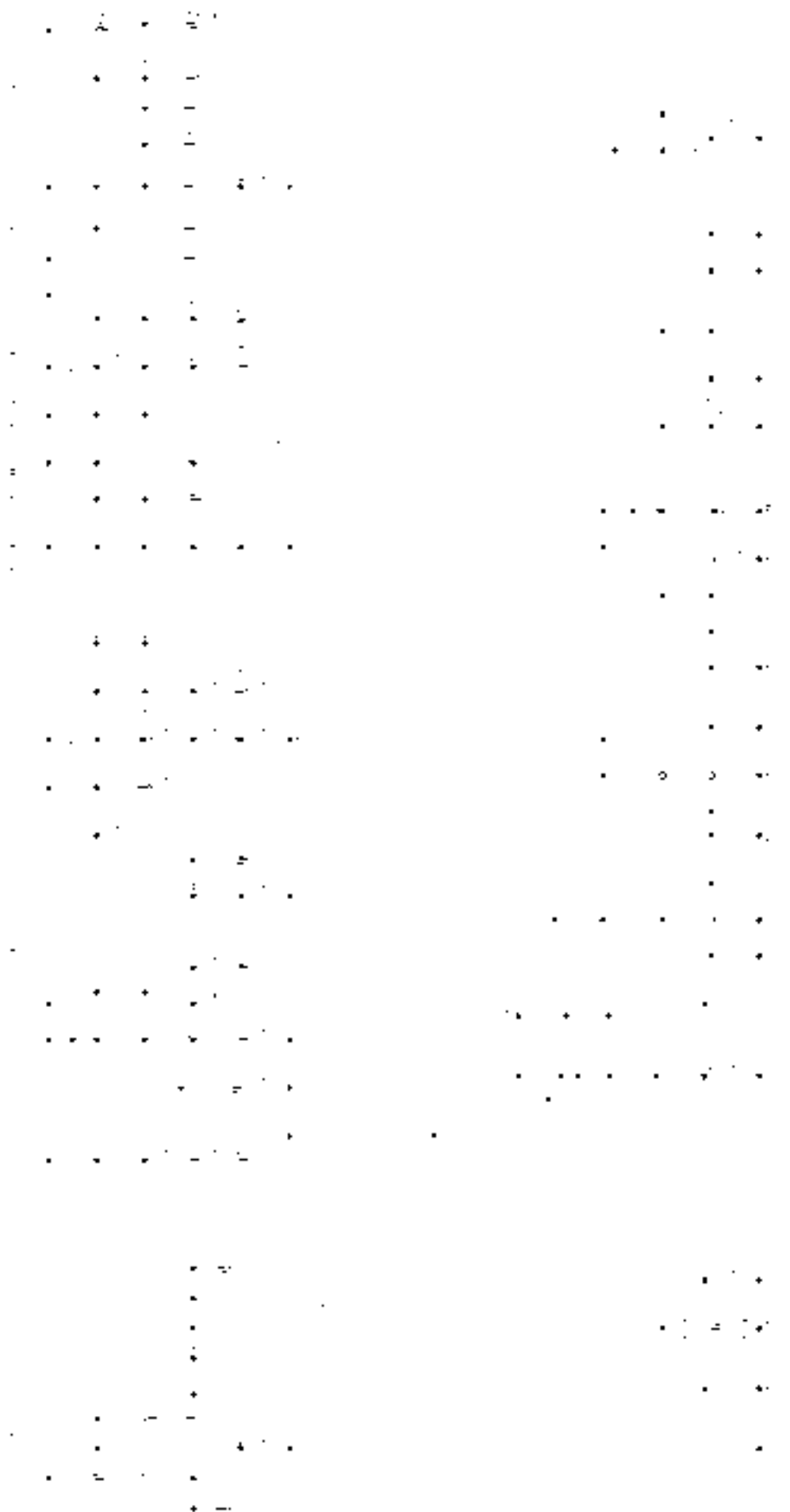

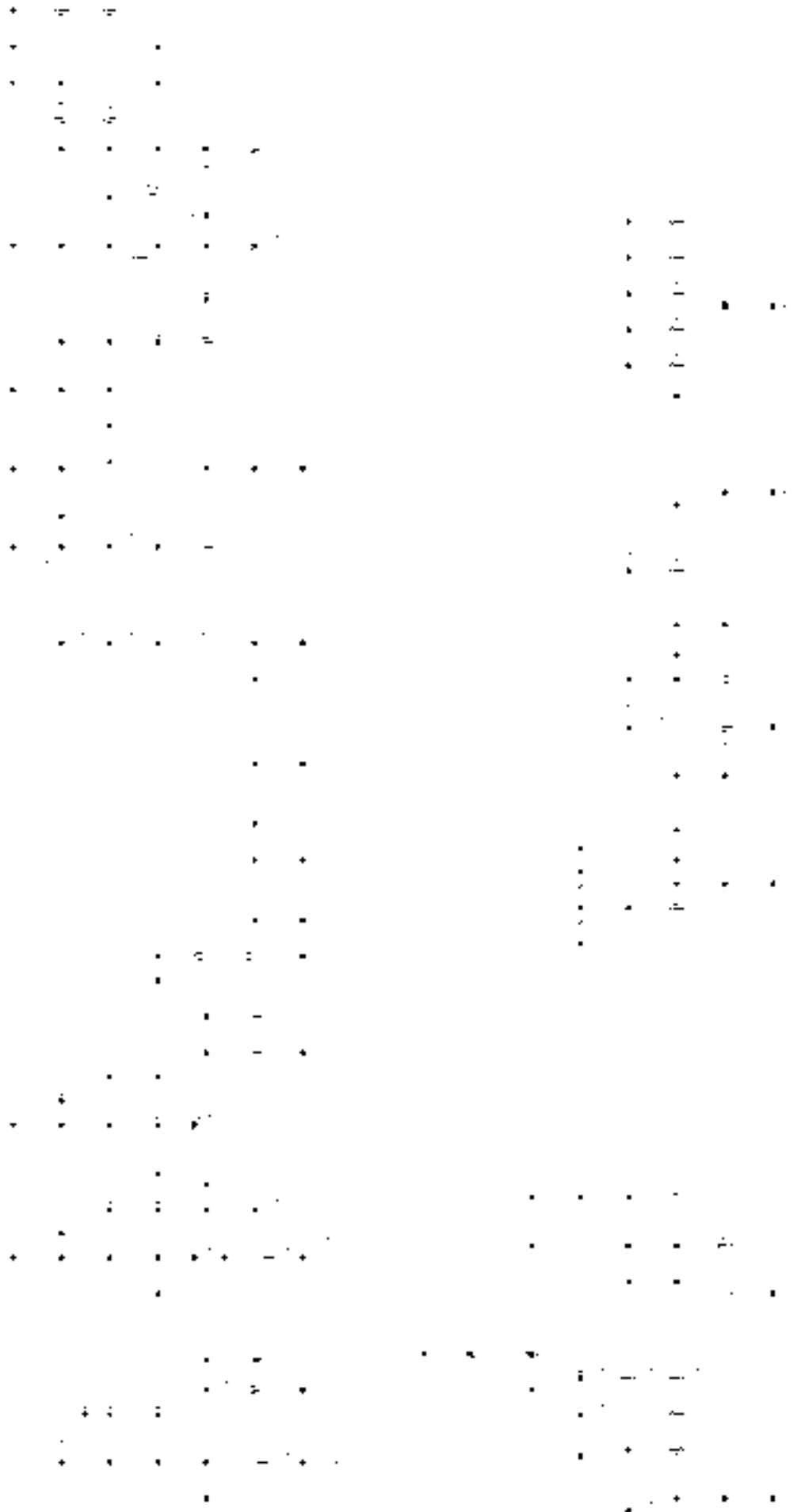

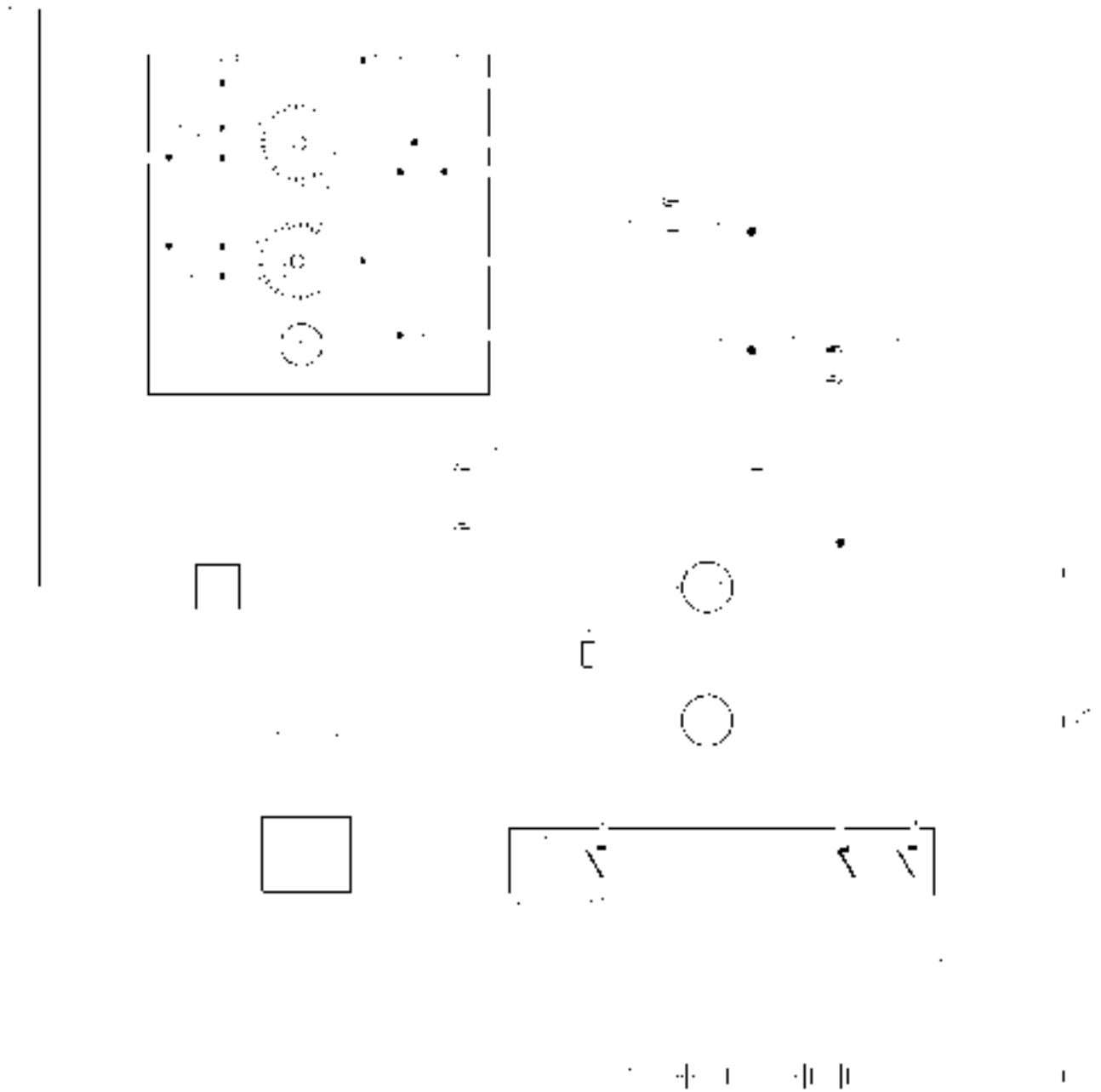

T3010061



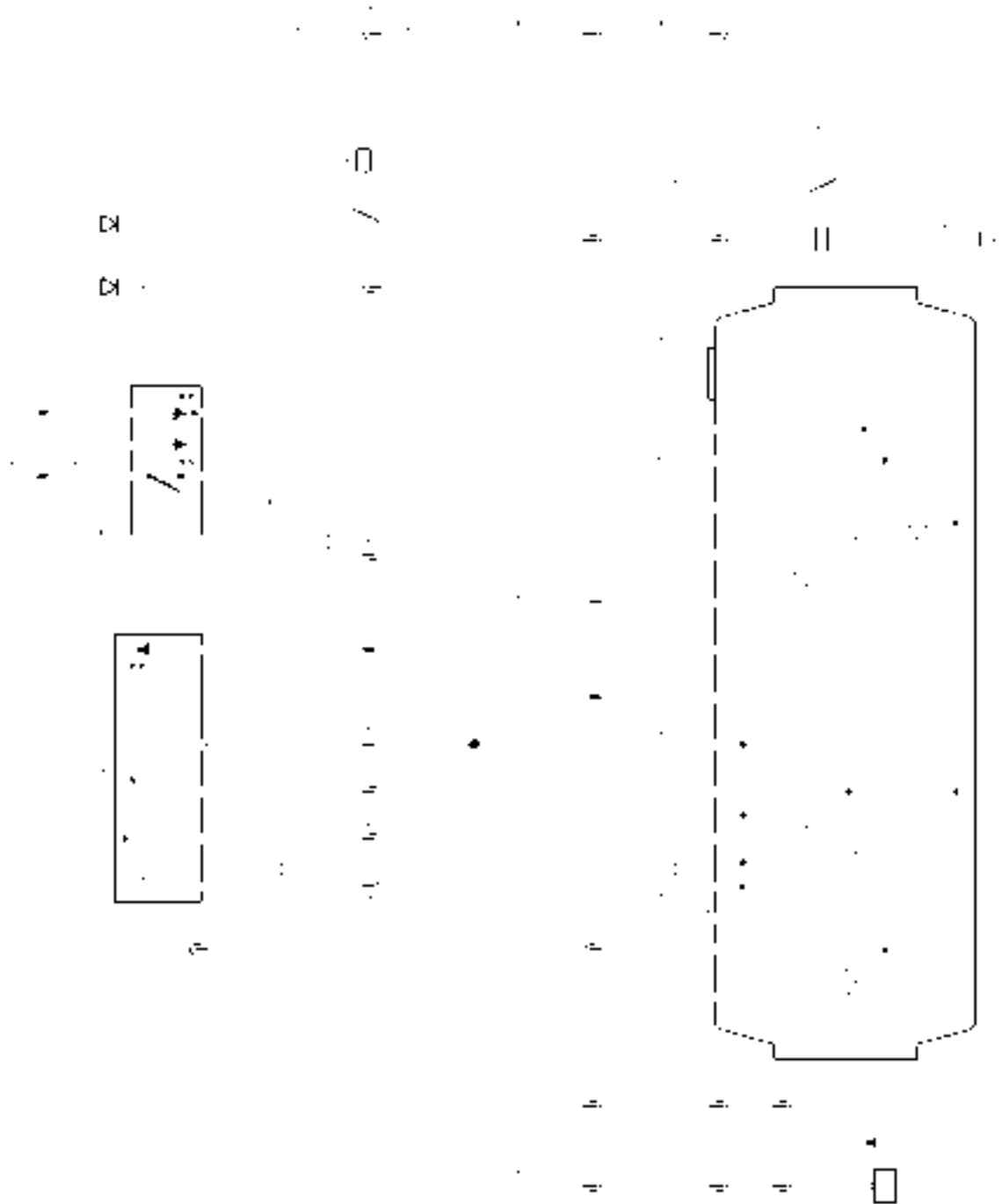

T3010062

## Illustrations index

-	Earth connections .....	page 49
-	Battery cables .....	page 50
650	Windscreen wiper motor .....	page 88
1000	Cable harness, instruments .....	page 55
1002	Cable harness, tachograph (CABLE-EC) .....	page 60
1006	Cable harness, cab, upper .....	page 61
1007	Cable harness, cab, lower .....	page 63
1017	Cable harness, engine/cab heater .....	page 65
1020	Cable harness, cowl .....	page 66
1030	Cable harness, engine .....	page 67
1037	Cable harness, bogie lift .....	page 70
1042	Cable harness, tail lights .....	page 71
1056	Cable harness, air dryer .....	page 72
1057	Cable harness, chassis .....	page 73
1061	Cable harness, parking heater, cab .....	page 74
1062	Cable harness, parking heater, frame .....	page 76
1072	Cable harness, air suspension .....	page 77
1074	Cable harness, hydraulic bogie lift with axle load limiter .....	page 80
1077	Cable harness, side marking lamp .....	page 82
1083	Cable harness, door .....	page 83
1084	Cable harness, cab, ABS .....	page 86
1086	Cable harness, solenoid valve, ABS .....	page 87
1097	Cable harness, bogie lift feeder cable .....	page 81
1402	Cable harness, windscreen washers .....	page 88
1404	Cable harness, ADR .....	page 89
1425	Cable harness, pulse sensor - tachograph (CABLE-B) .....	page 60
1433	Cable harness, bogie lift - locking, 3rd axle .....	page 91
1440	Cable harness, el. operated rearview mirror .....	page 94
1454	Cable harness, cab tilt pump .....	page 95
1465	Cable harness, additional accessories .....	page 96
1468	Cable harness, water separator .....	page 97
1469	Cable harness, fuel filter heater .....	page 98
1476	Cable harness, engine, cab .....	page 99
1488	Cable harness, central lubrication system .....	page 103
1489	Cable harness, adapter, no tachograph .....	page 55

# Illustrations

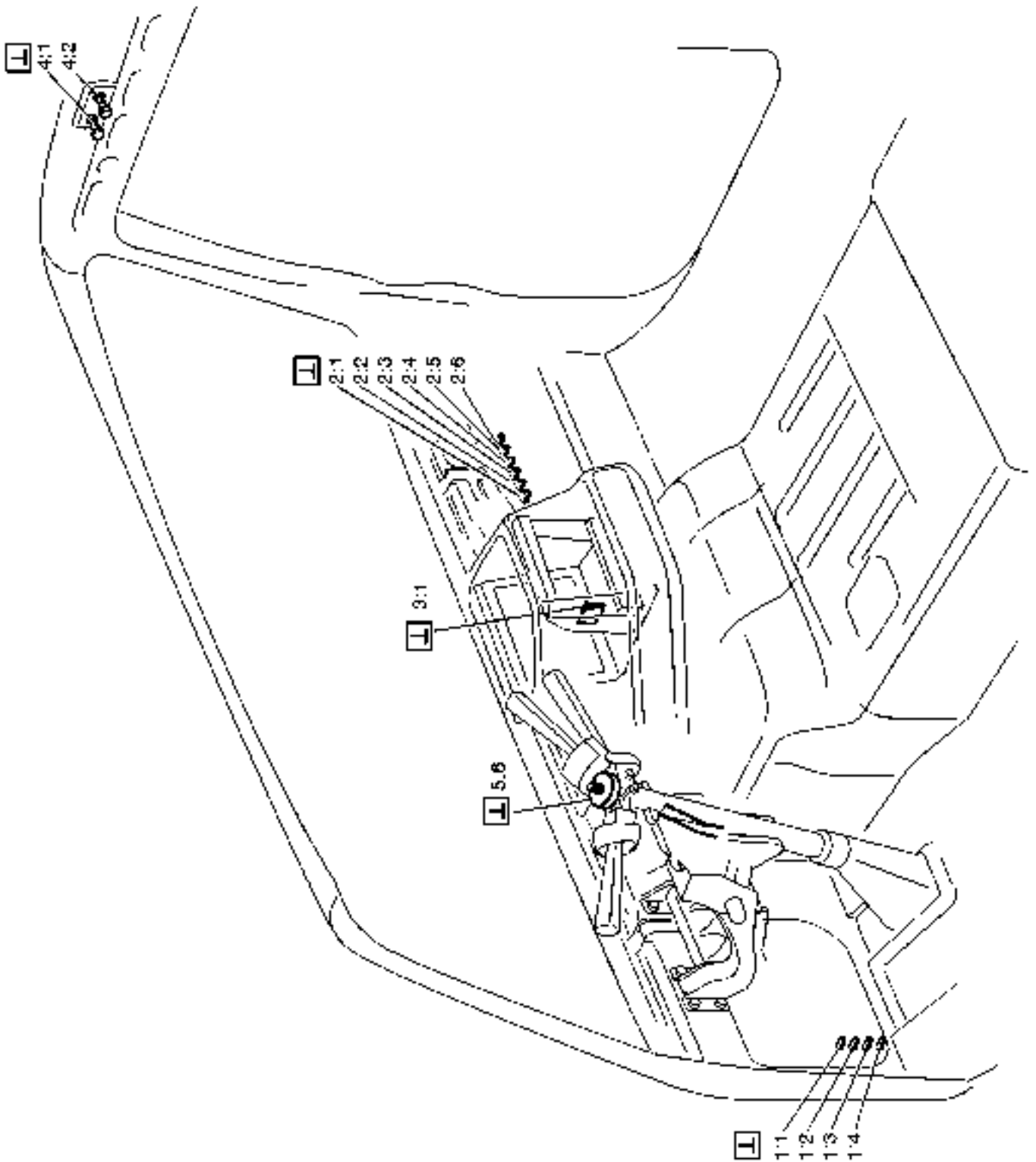

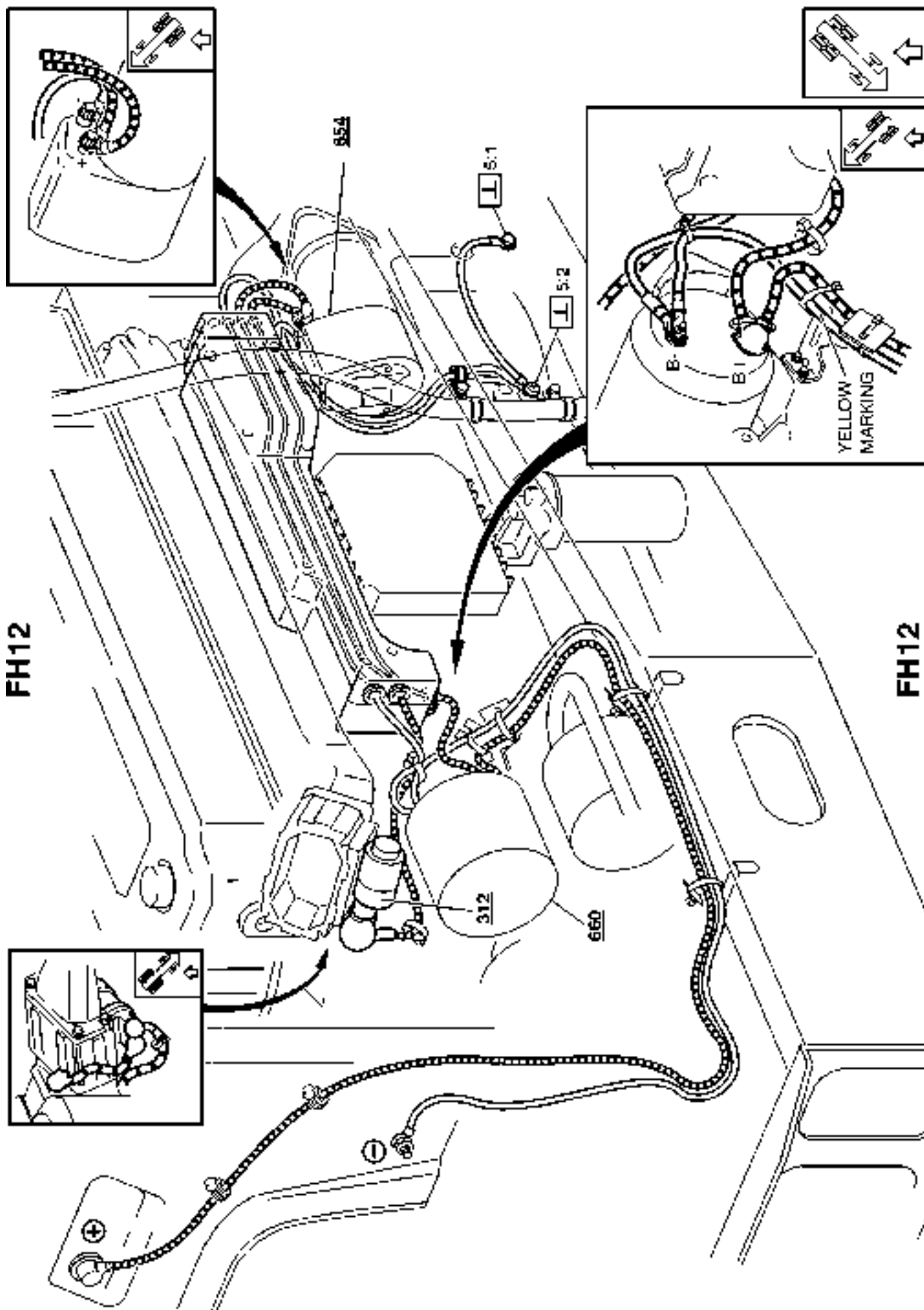

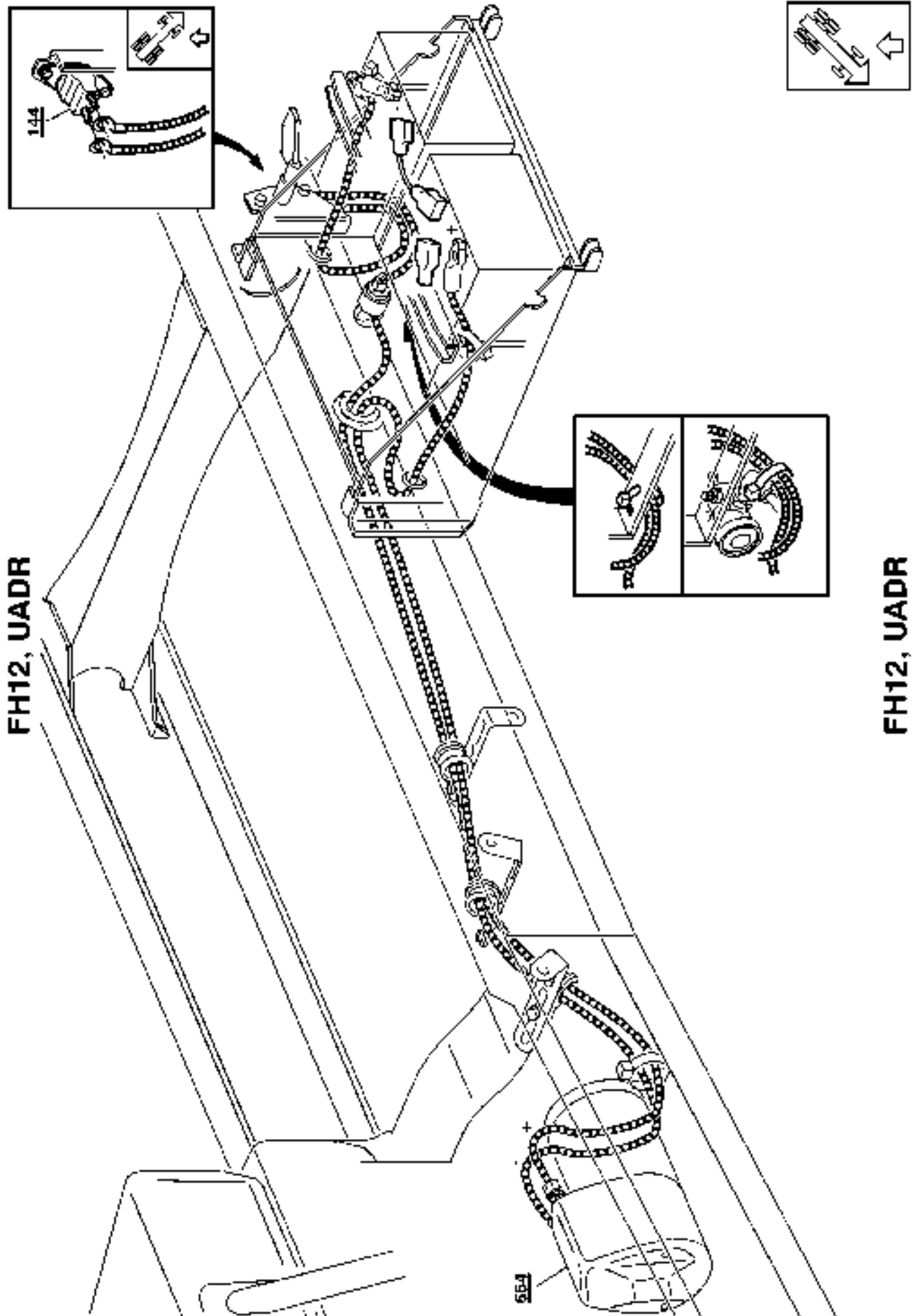

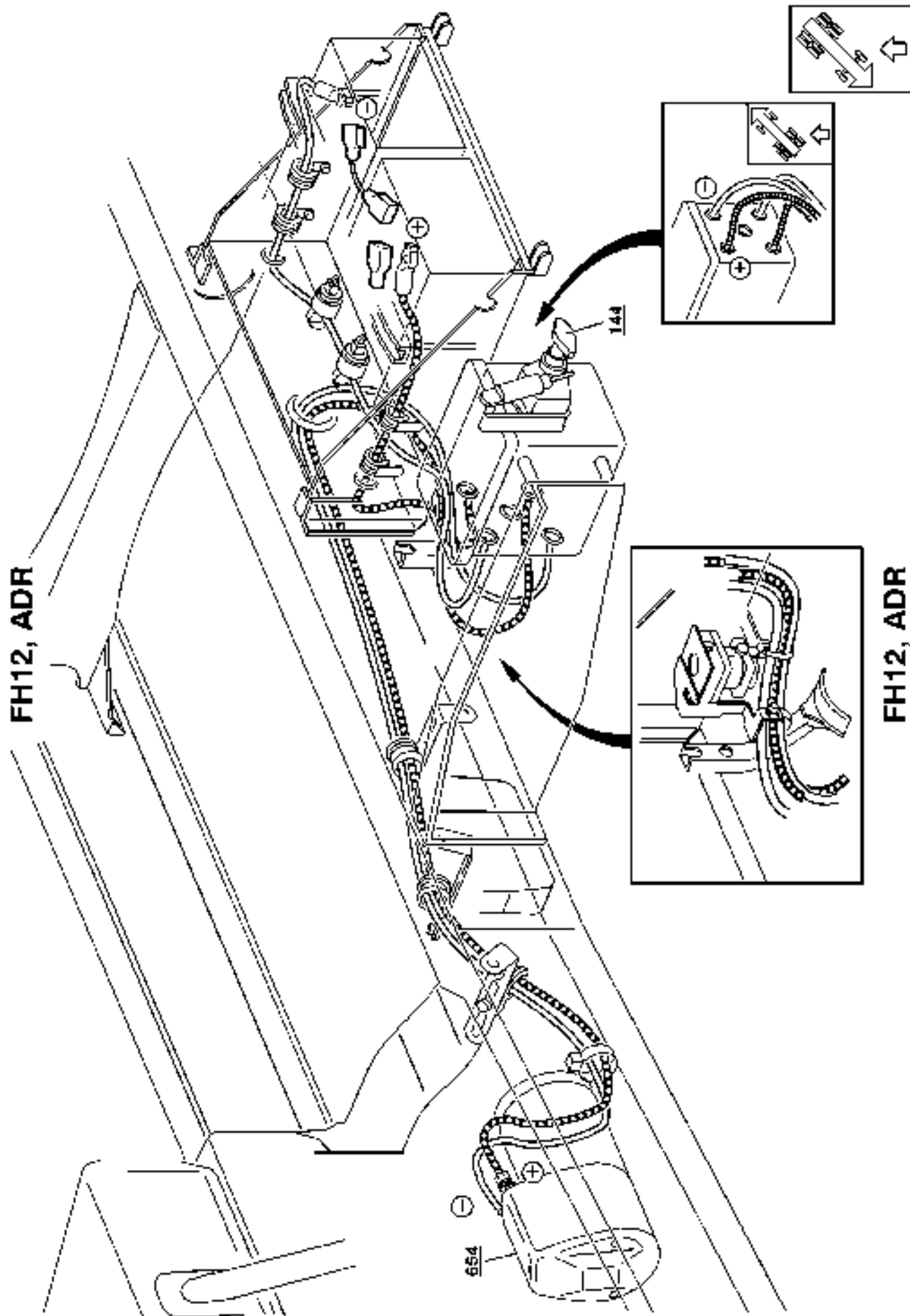

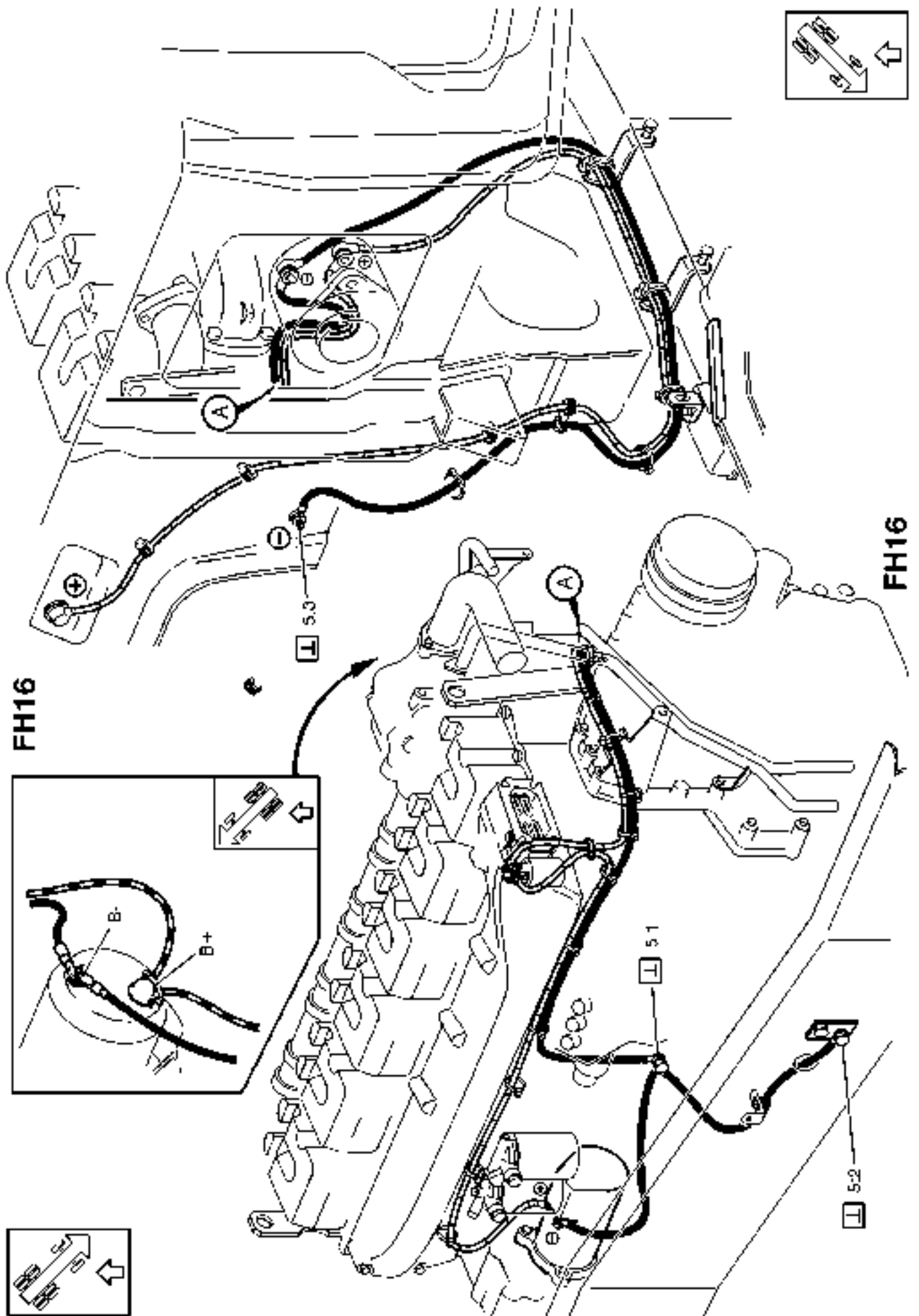

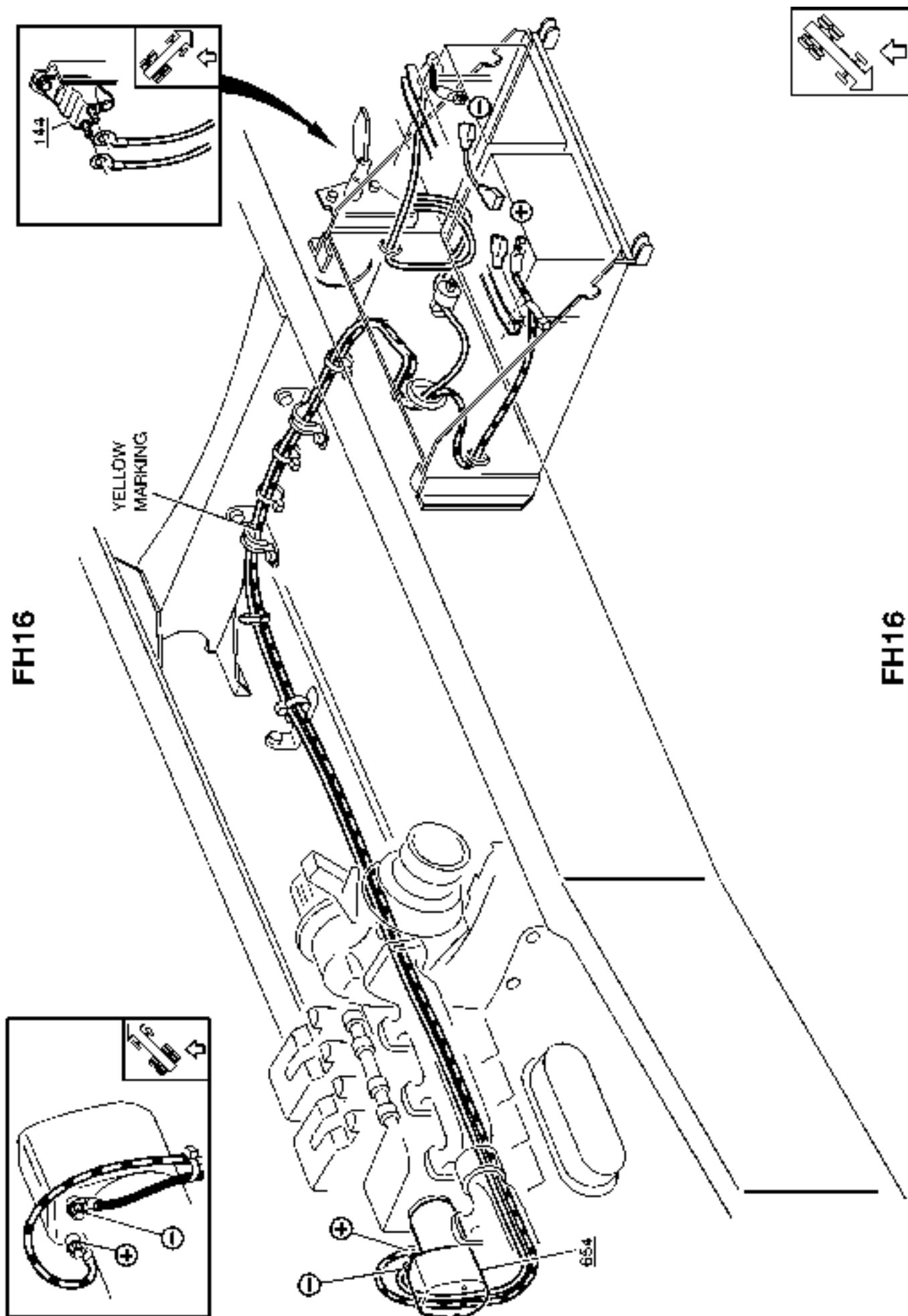





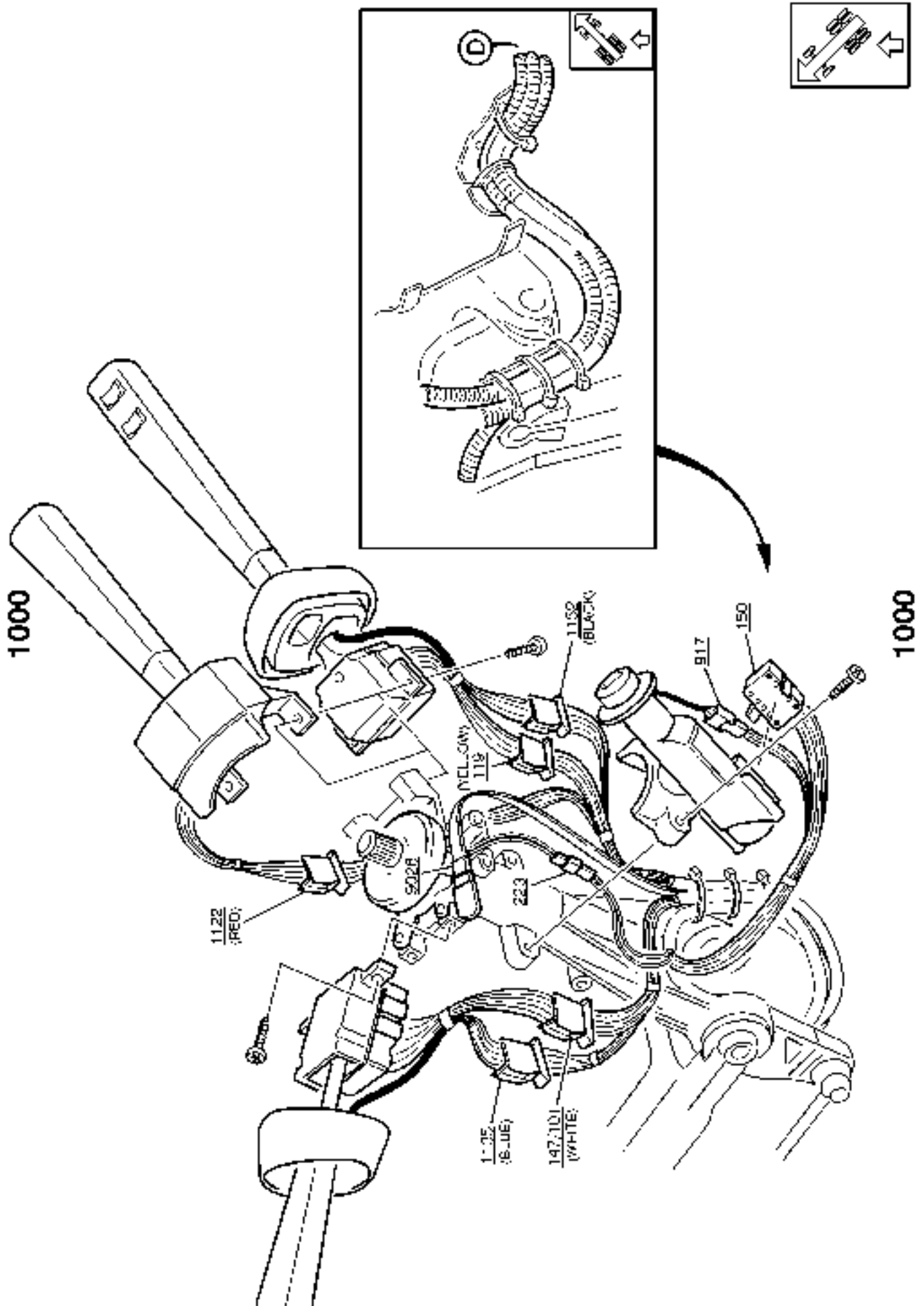



1000

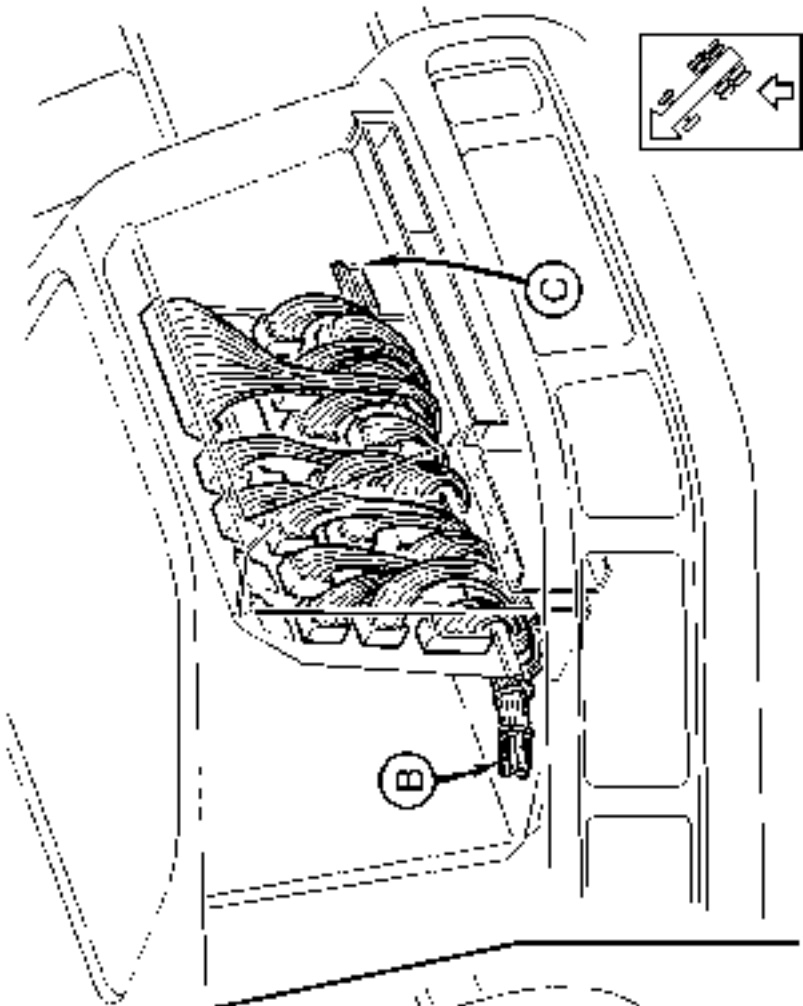

1000

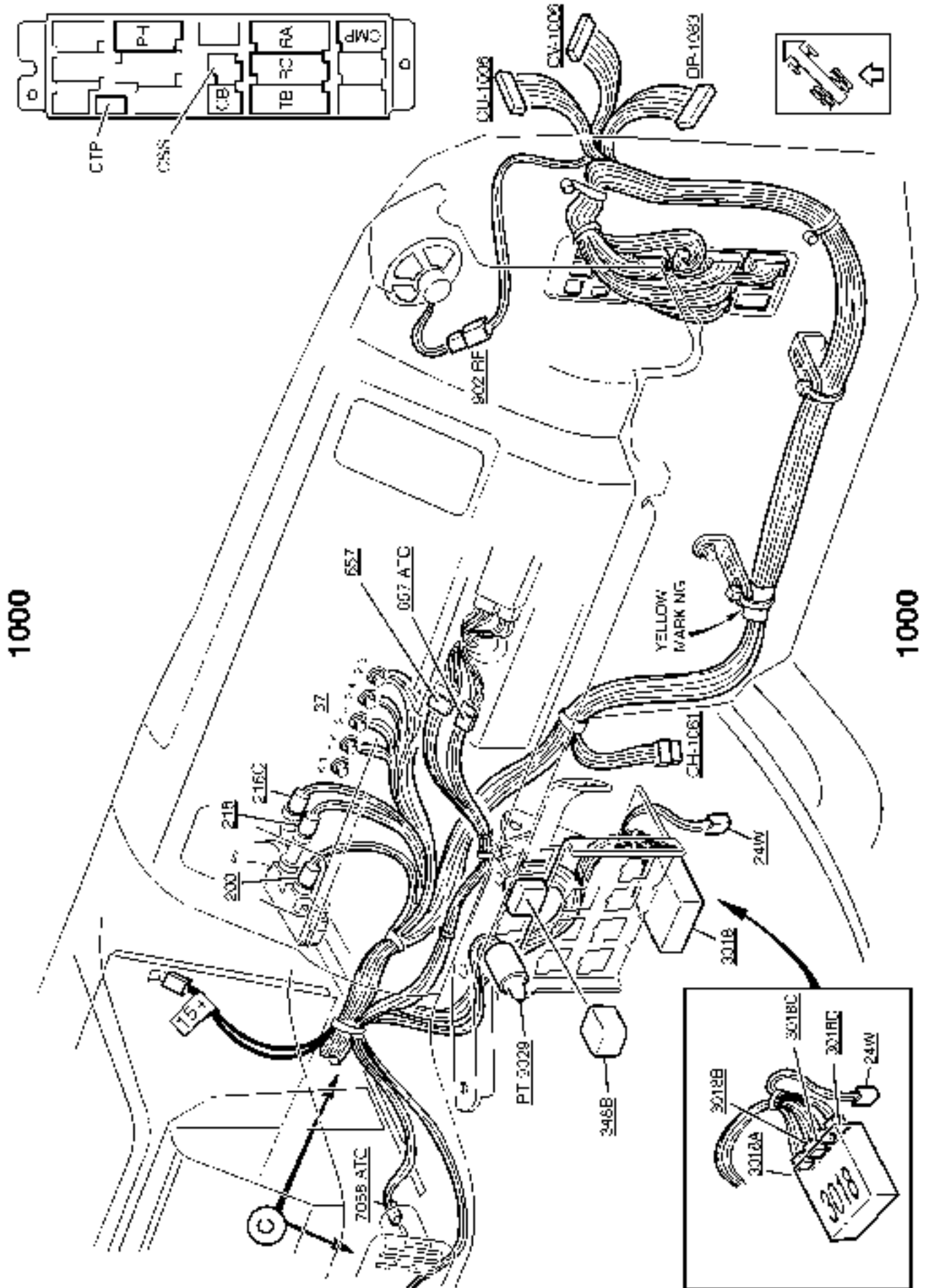

1002, 1425

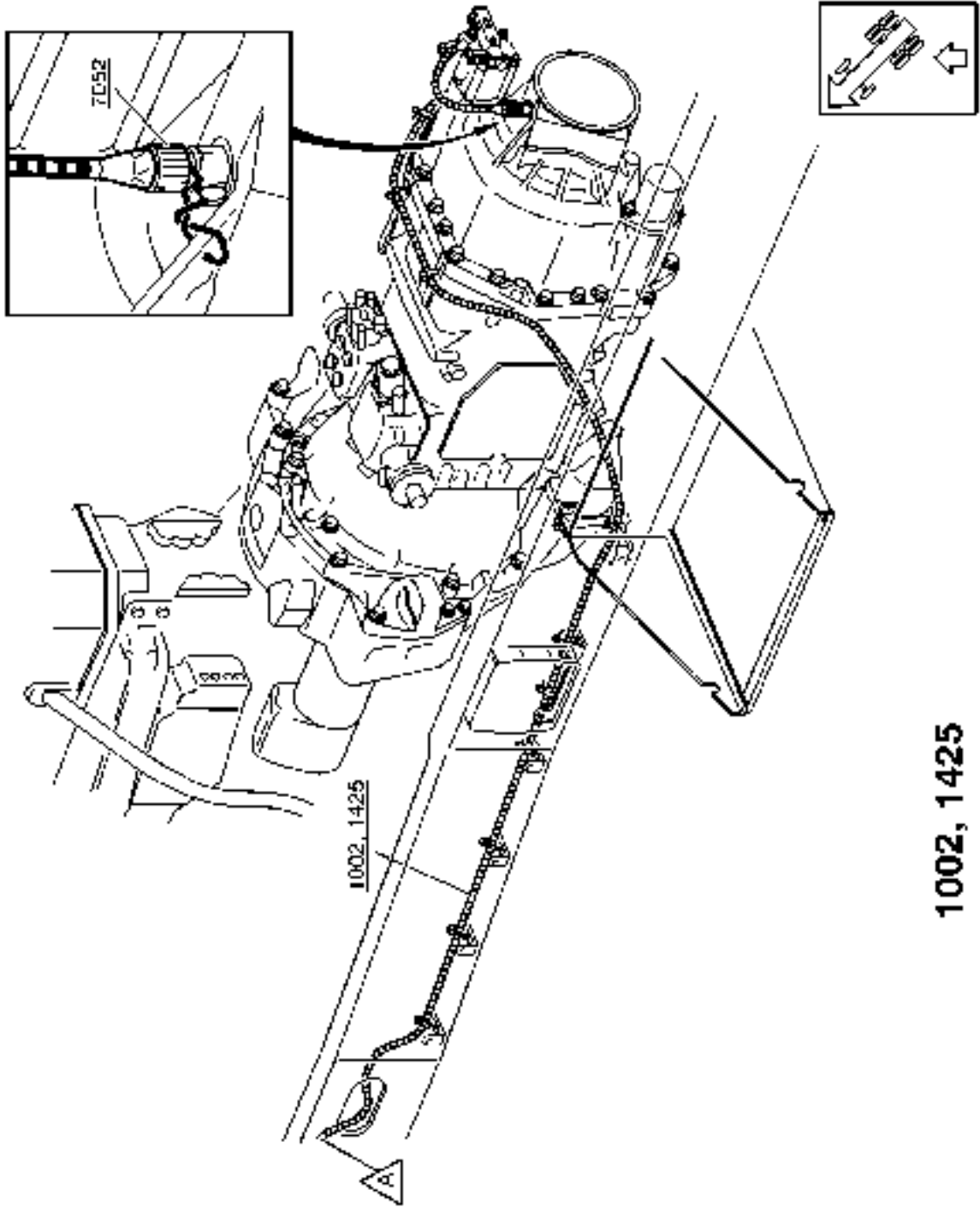

1002, 1425

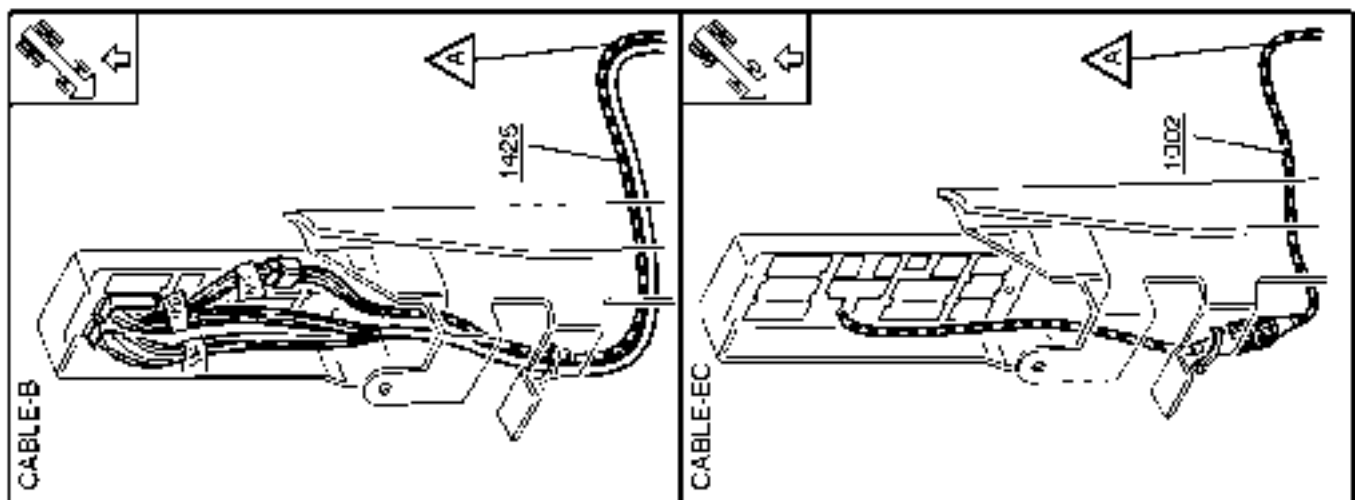

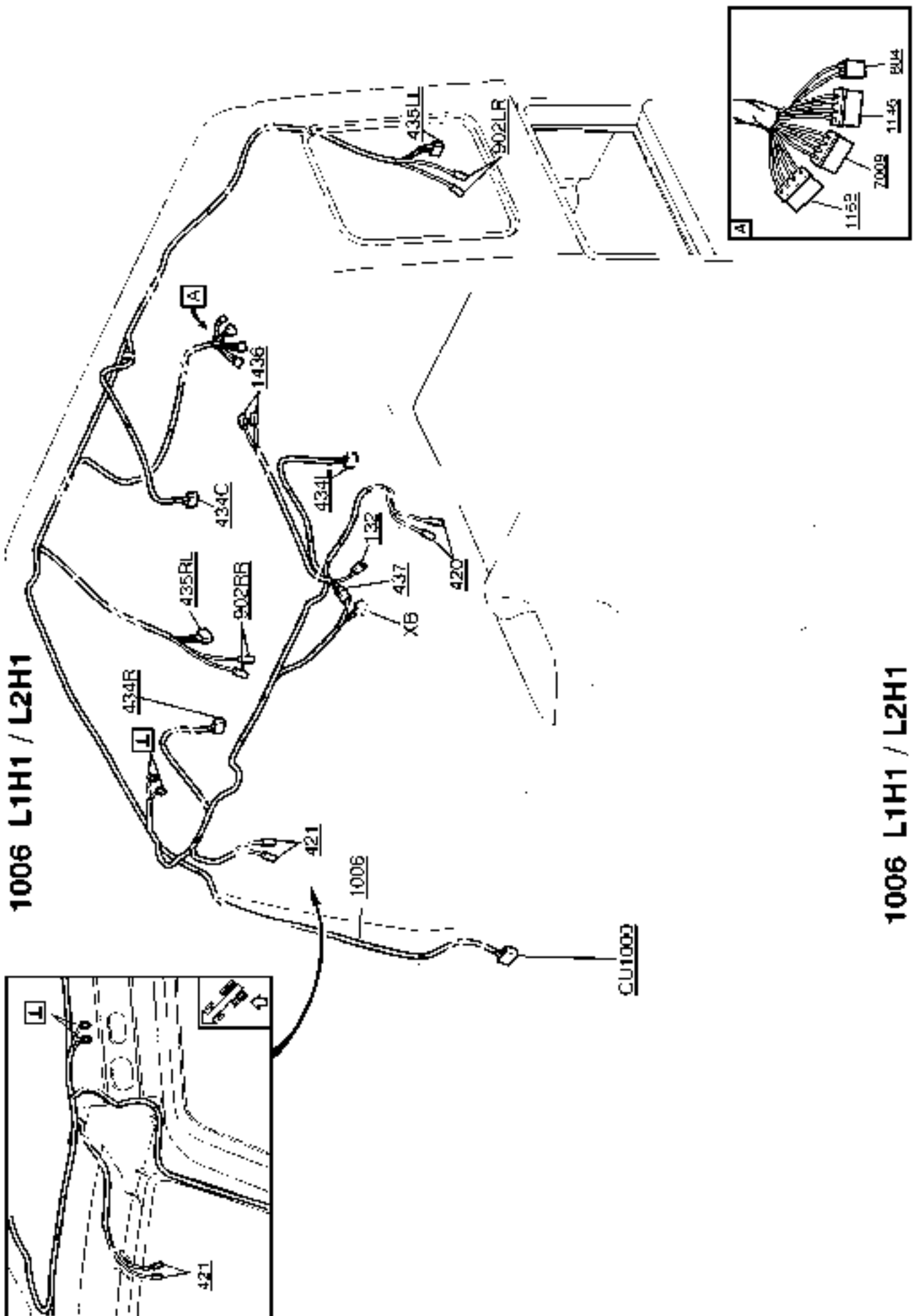

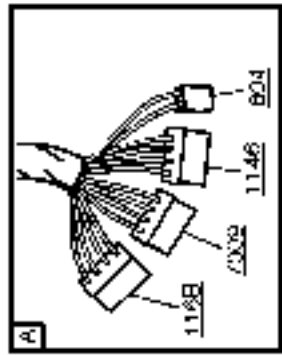

1006 L2H2

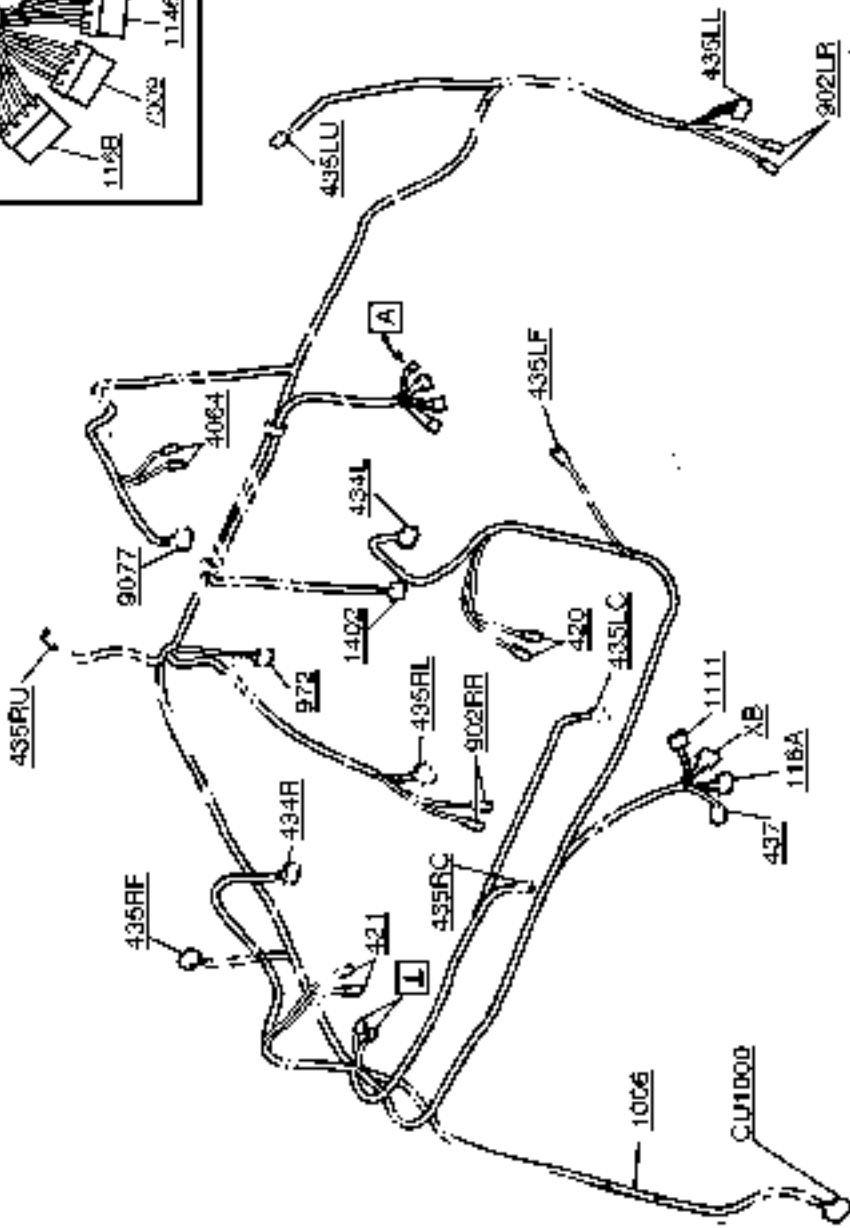

1006 L2H2

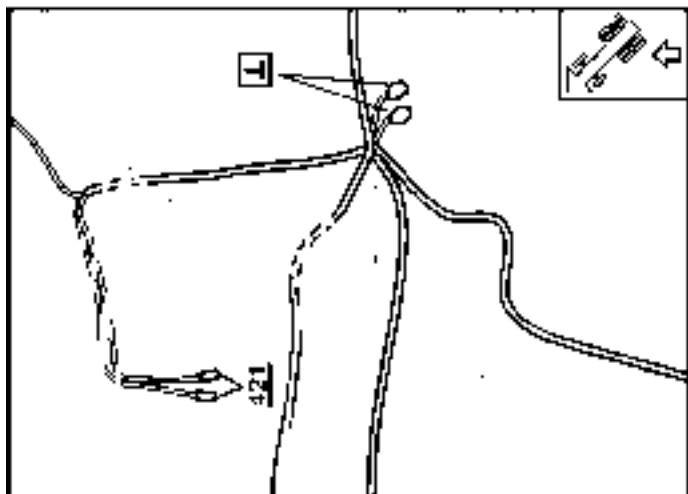



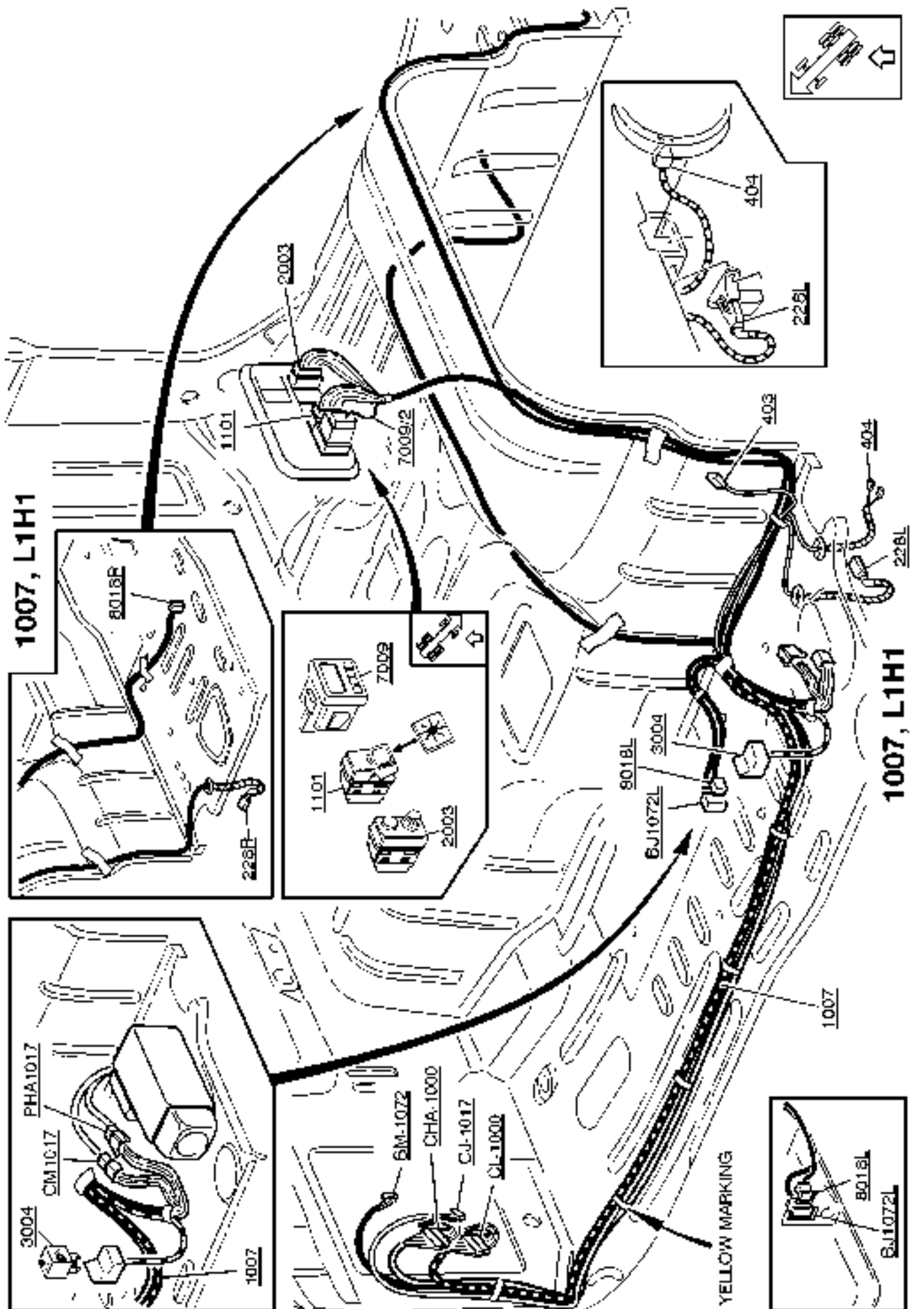

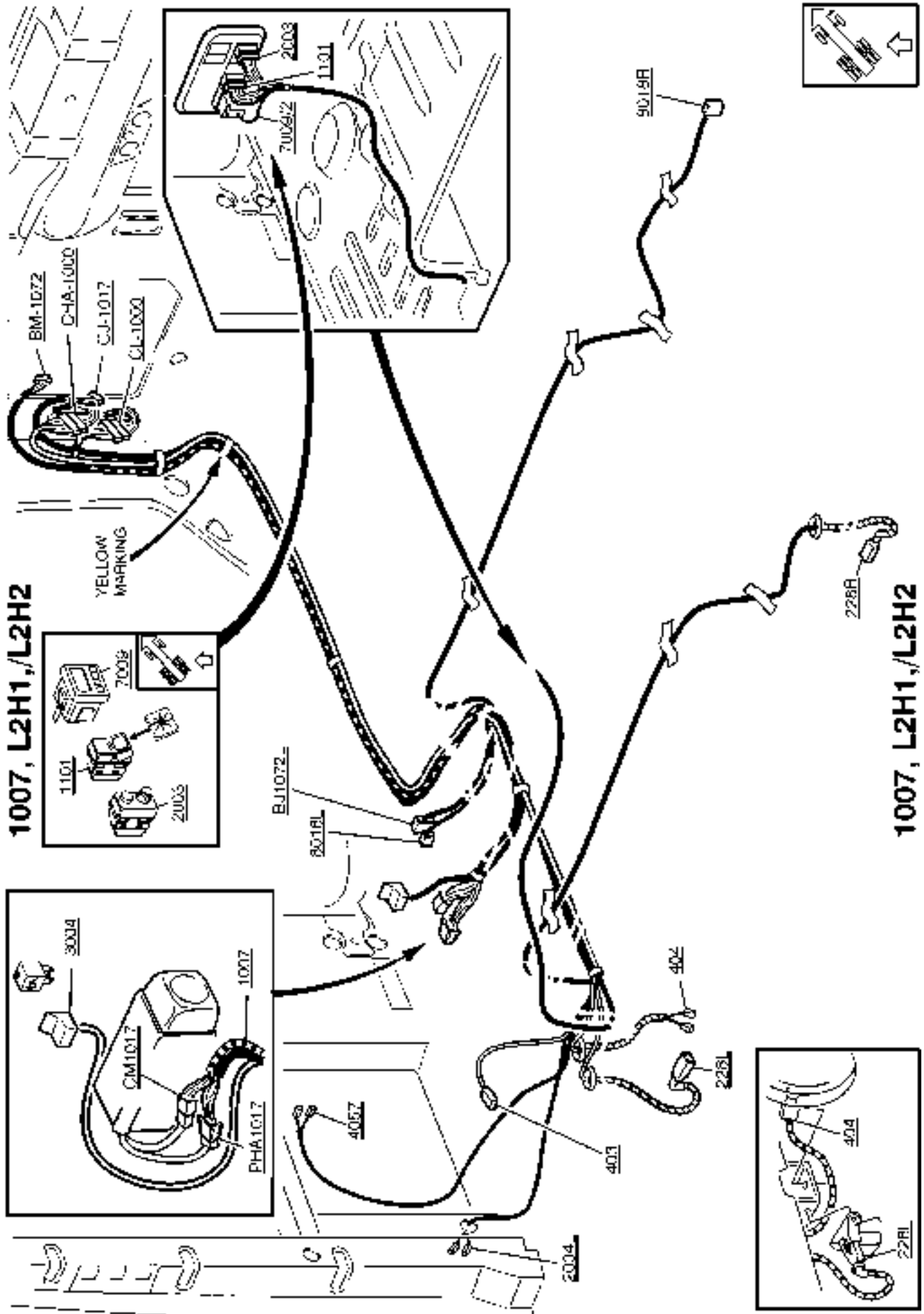

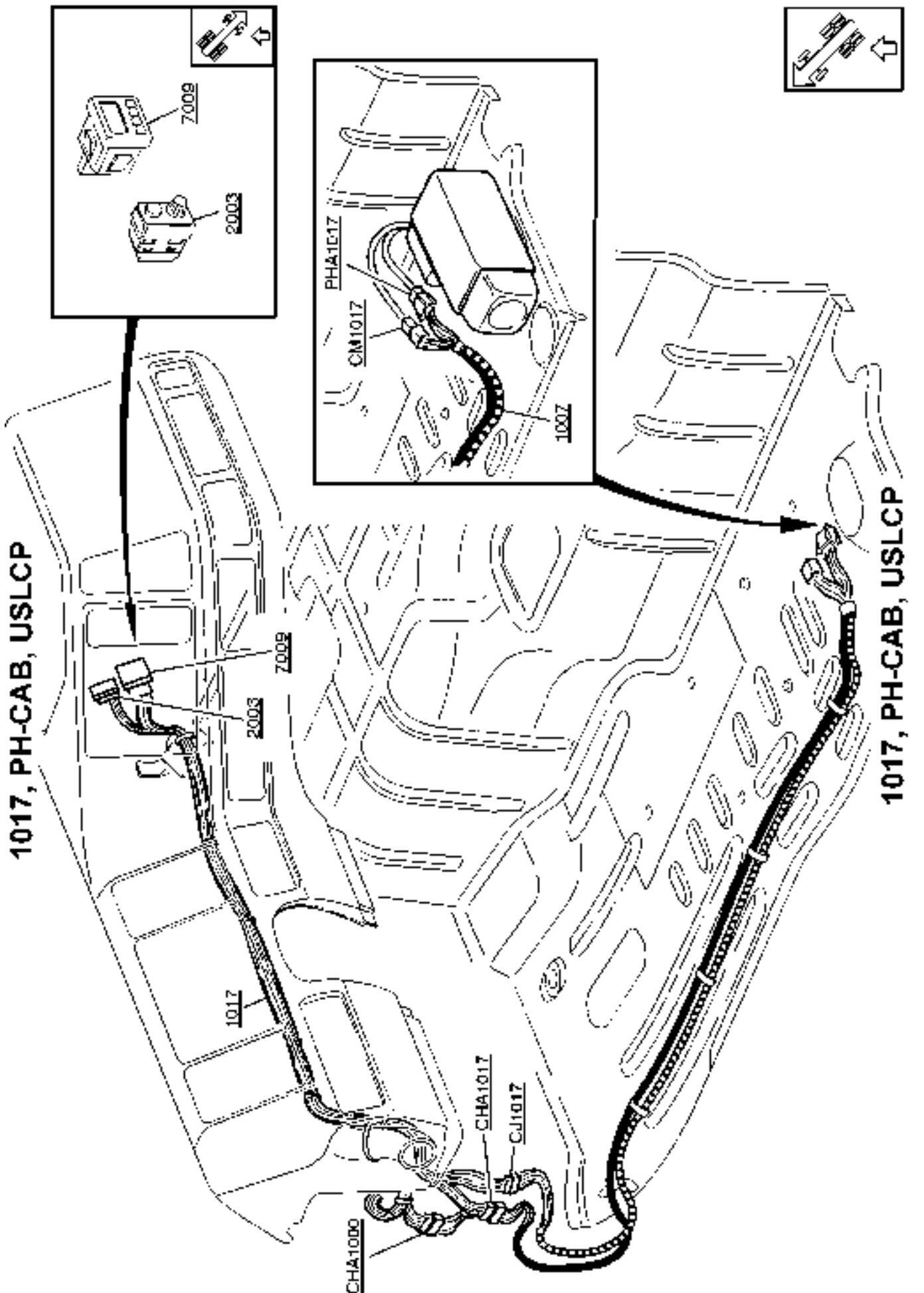

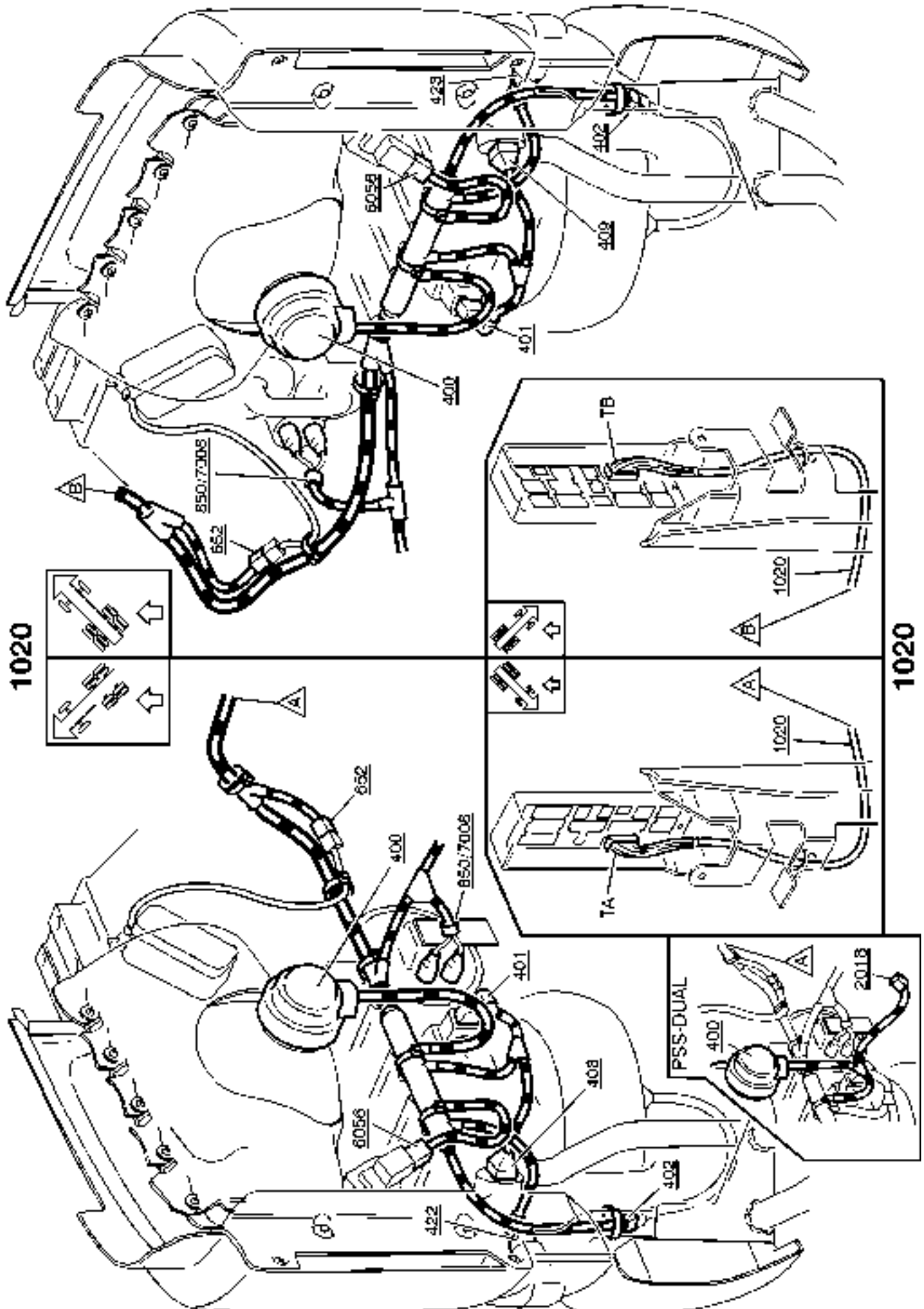

1030, FH12

1030, FH12

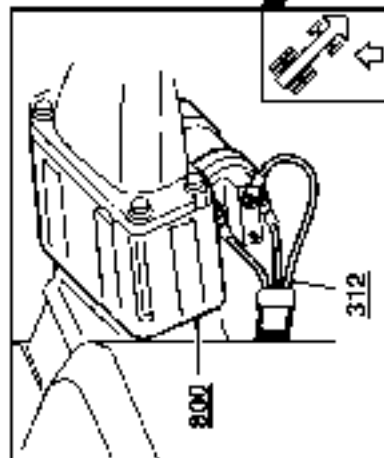
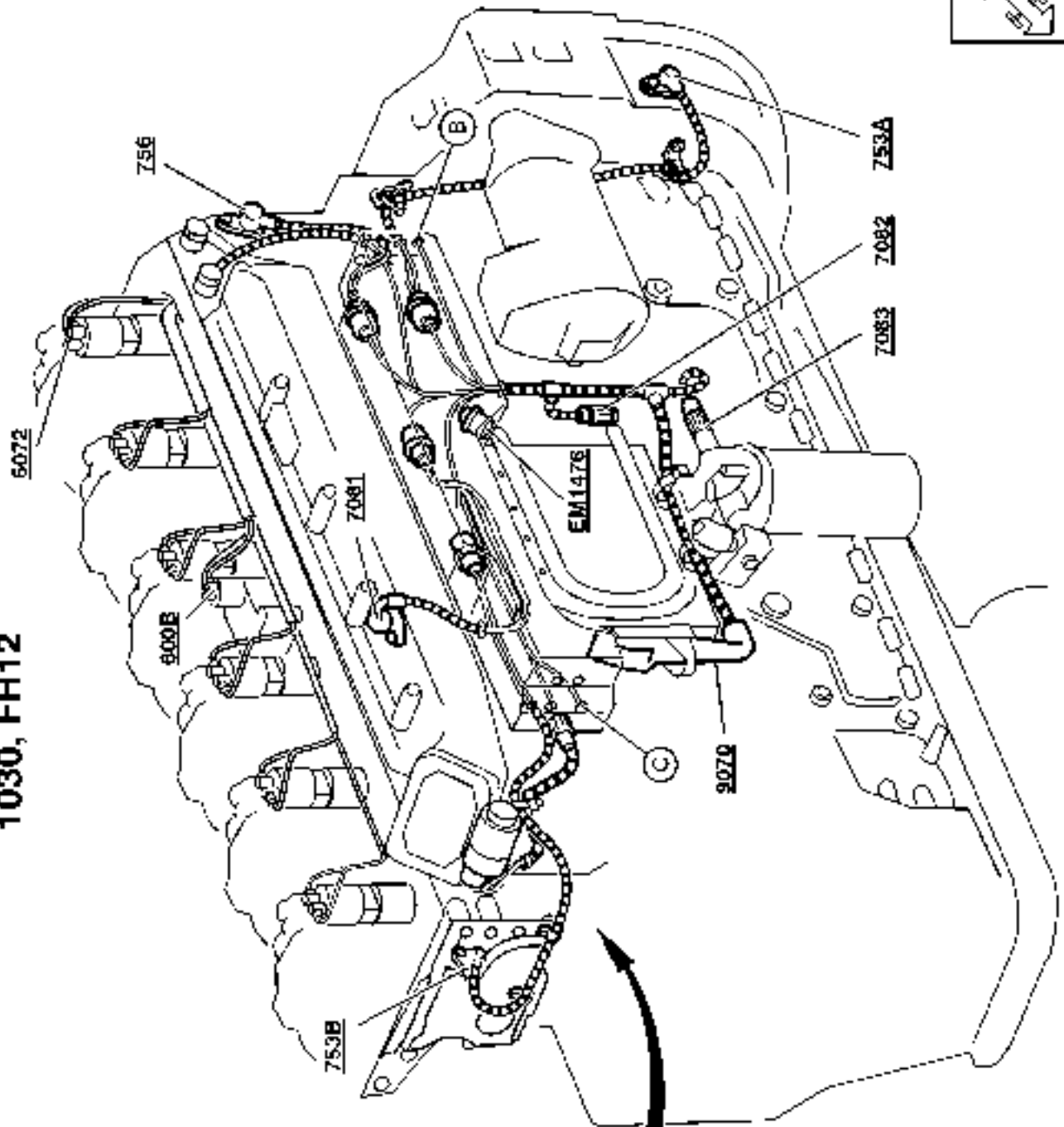

1030, FH12

1030, FH12

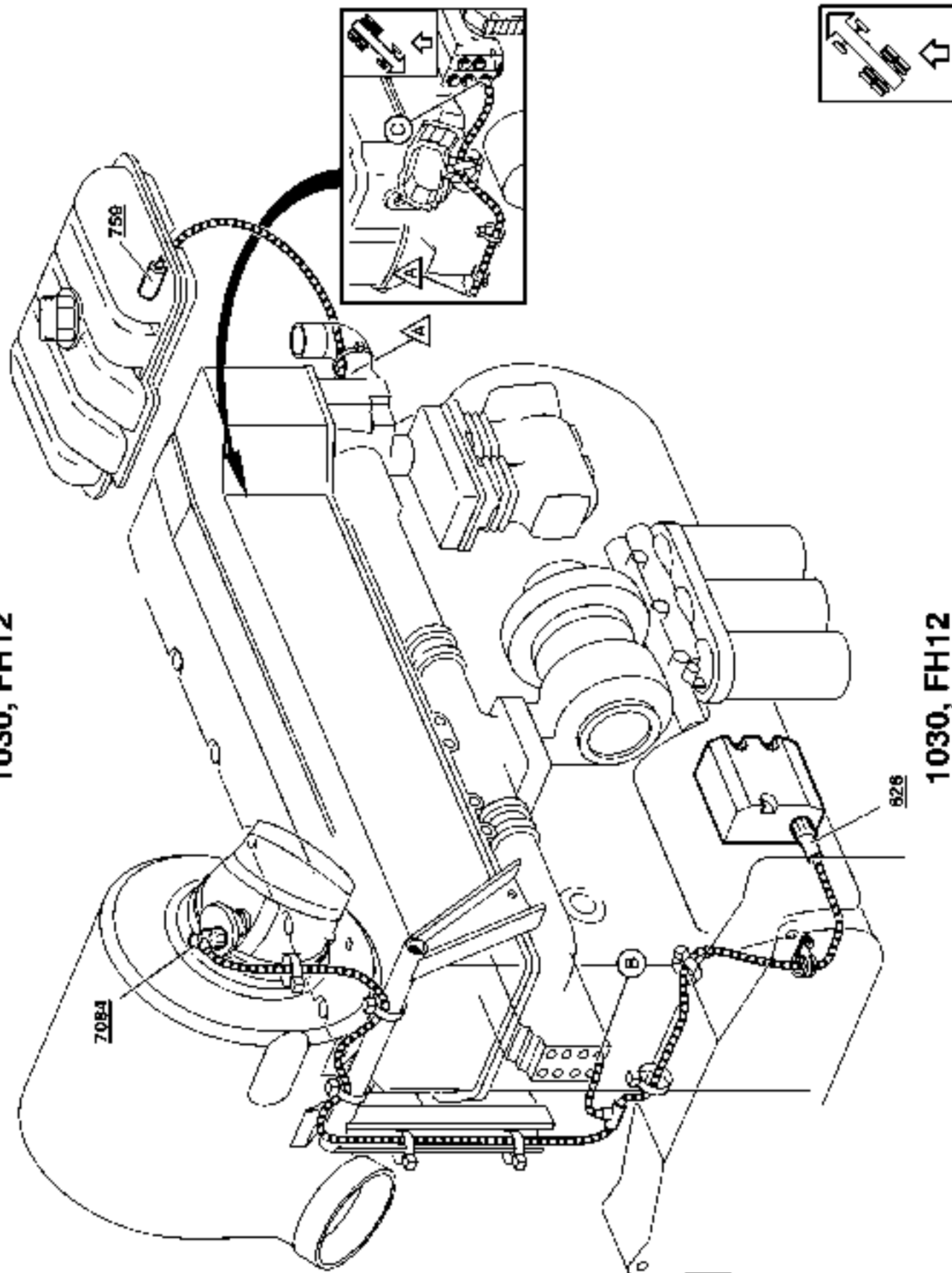

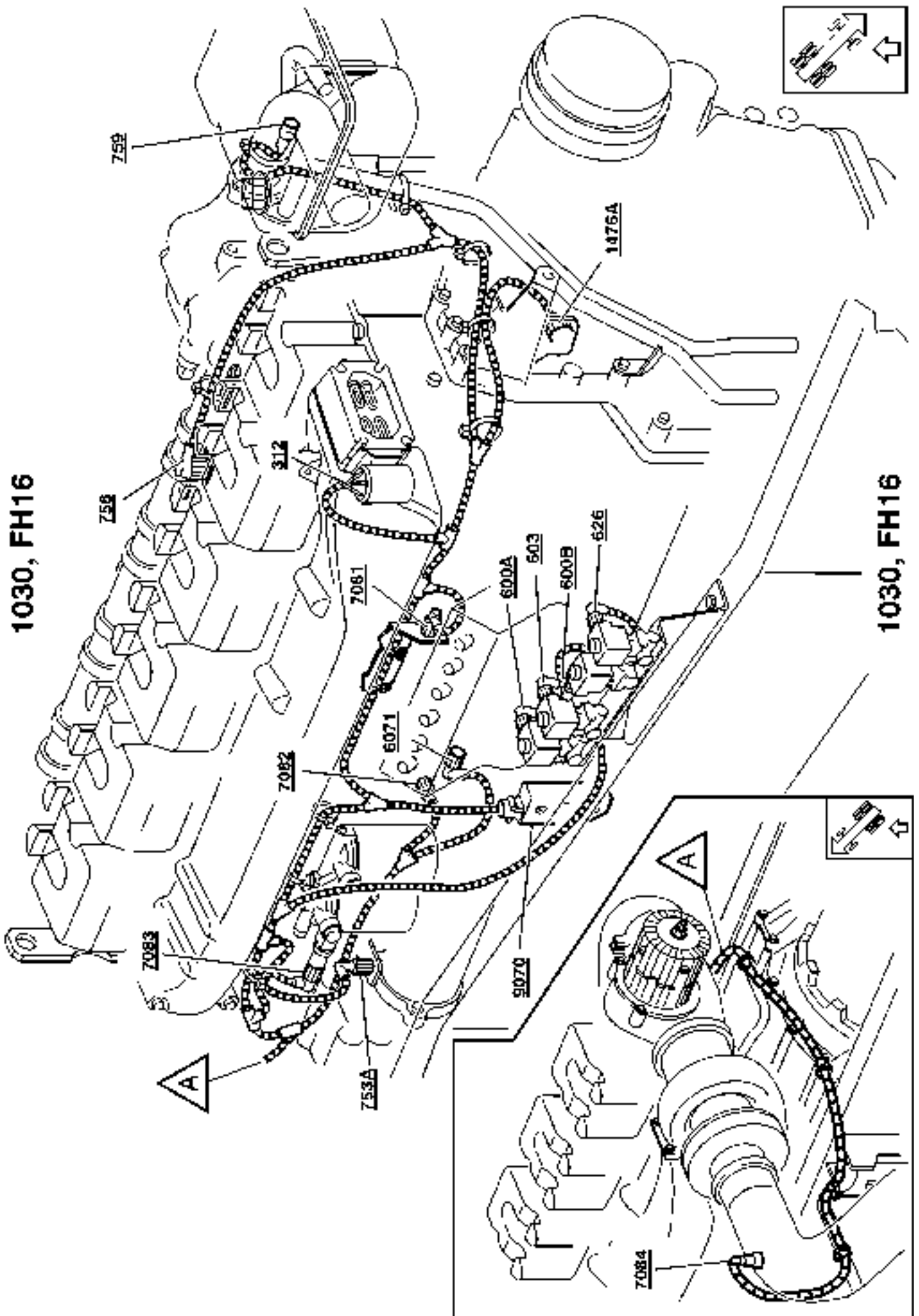

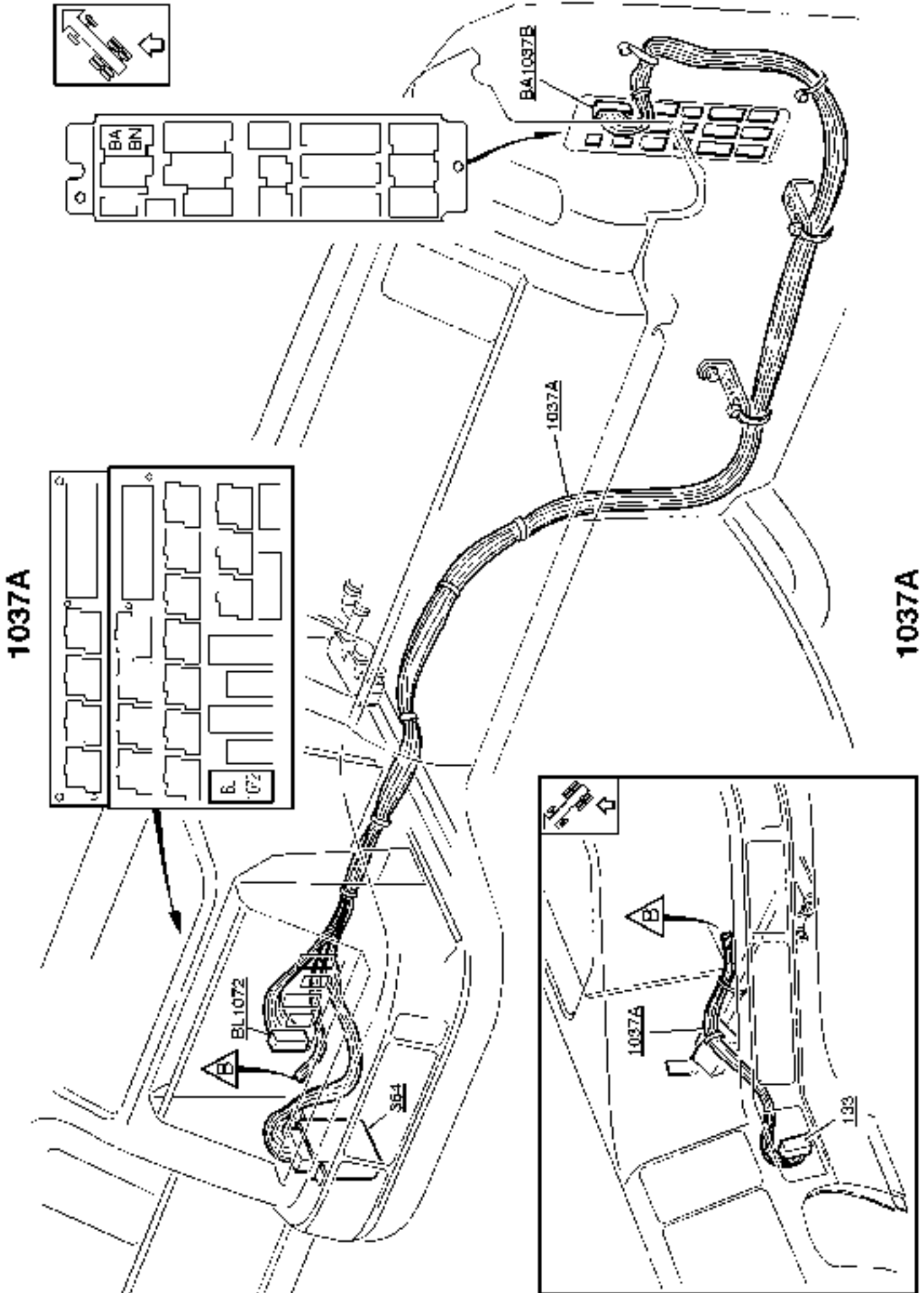



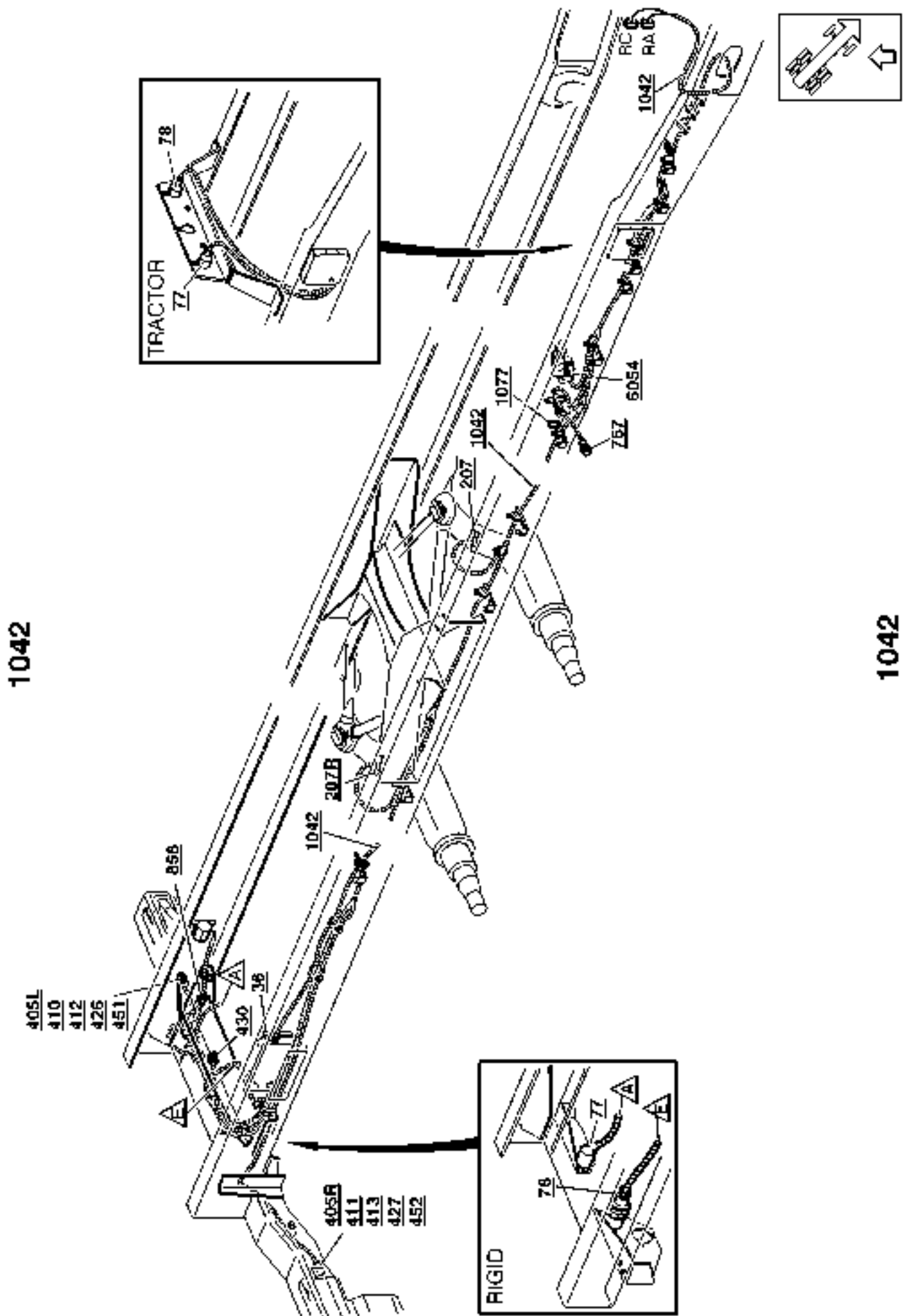

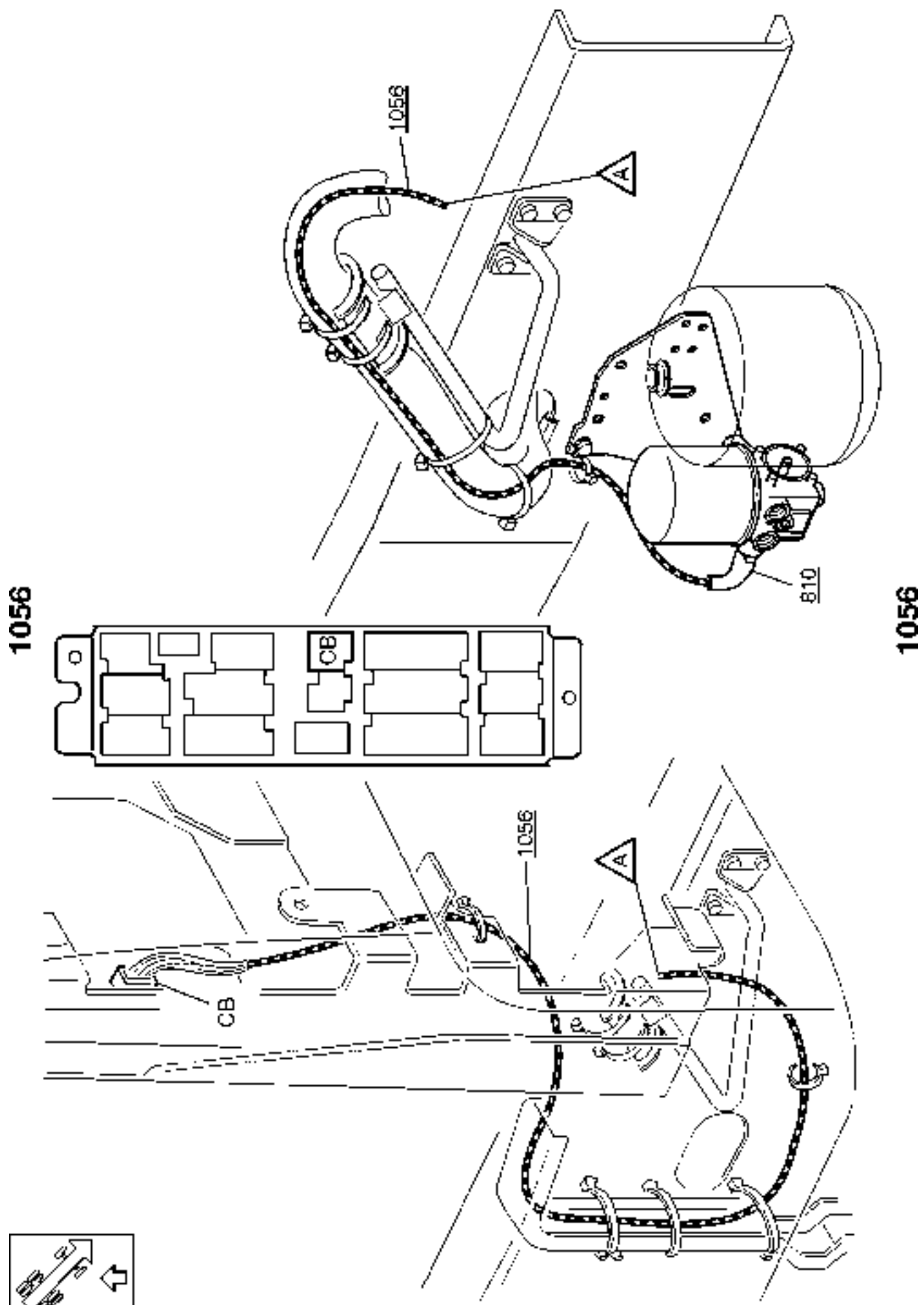

1057

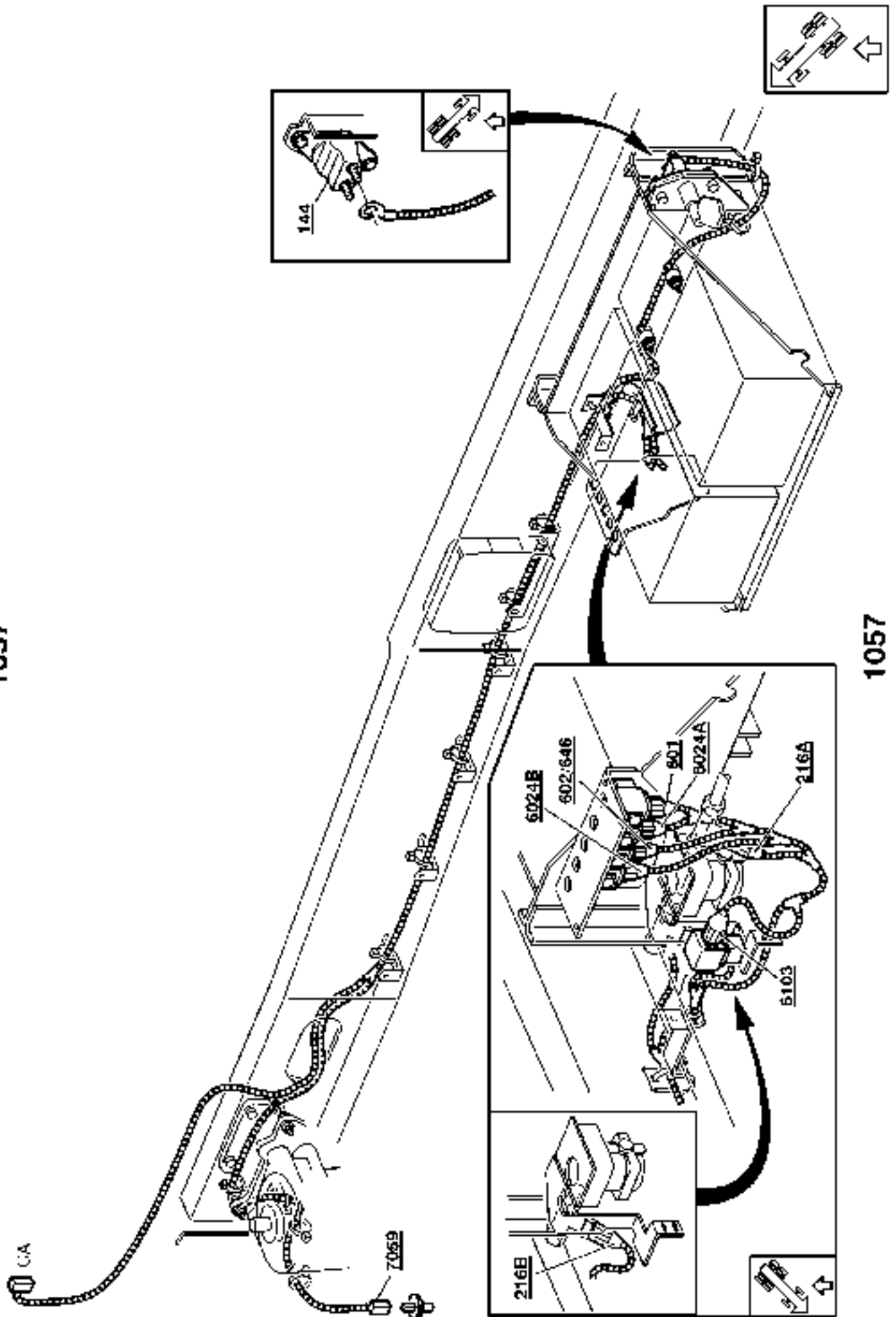

1057

1061, PH-ENGCA, USLCP

1061, PH-ENGCA, USLCP

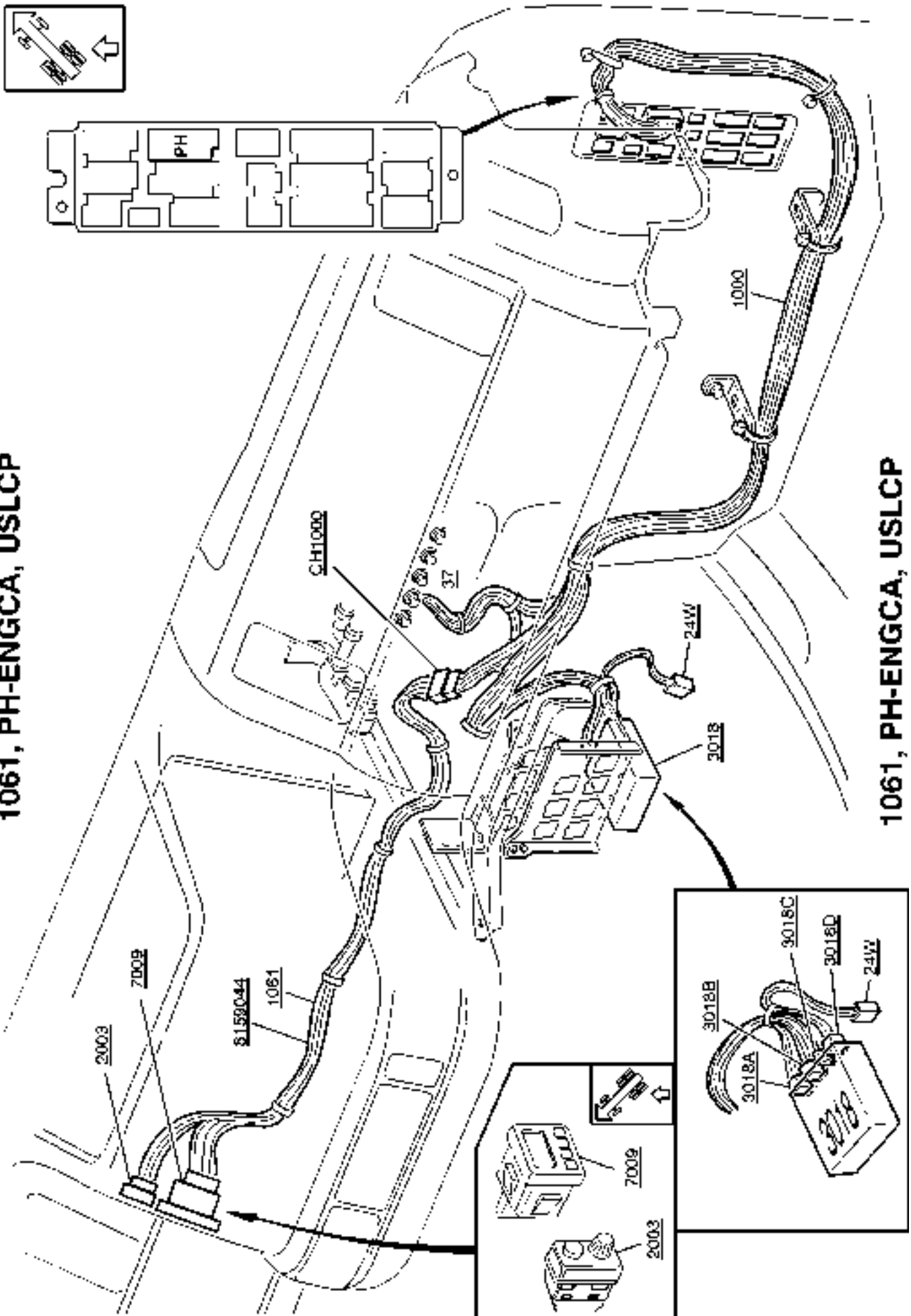

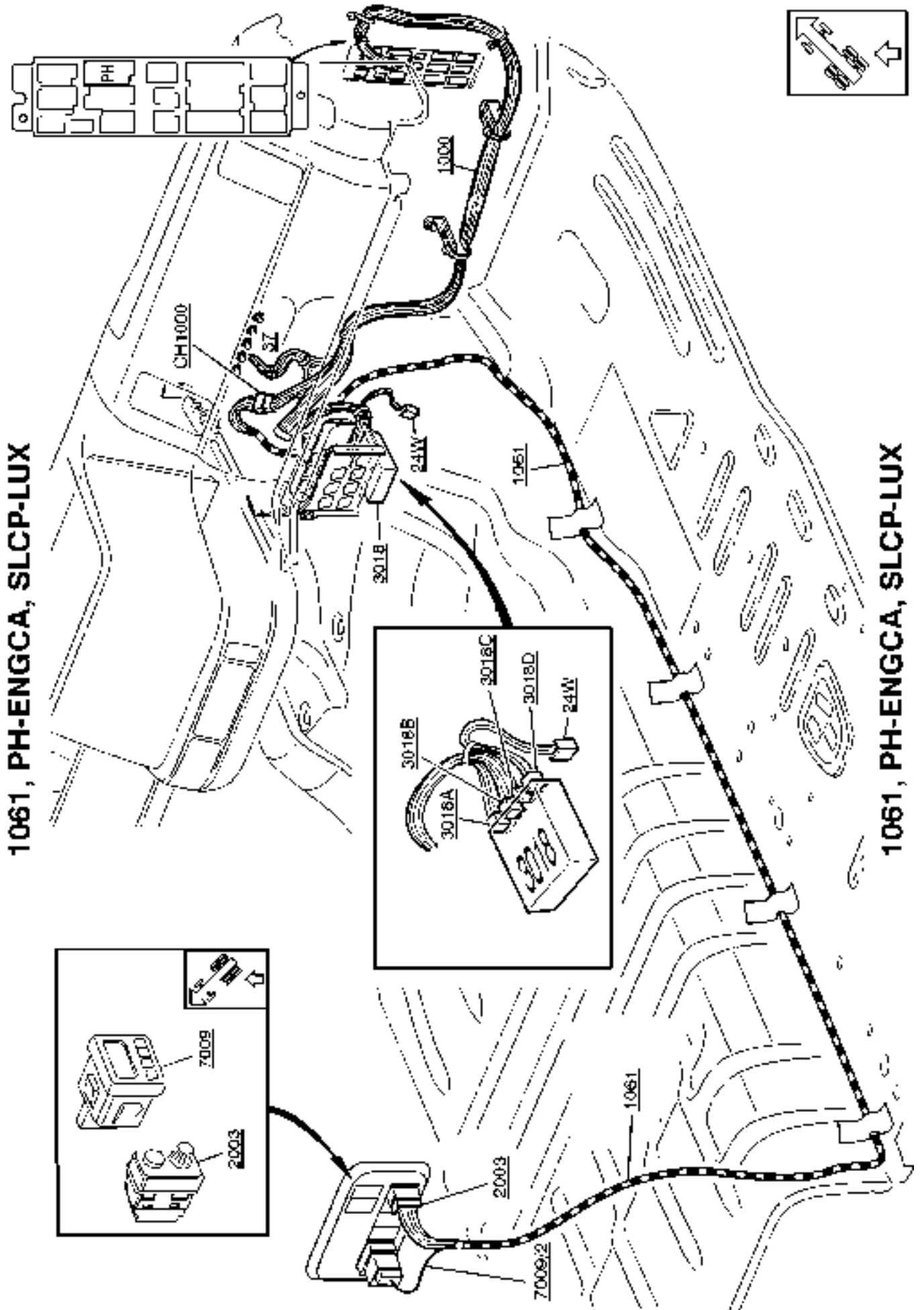

1061, PH-ENGCA, SLCP-LUX

1061, PH-ENGCA, SLCP-LUX

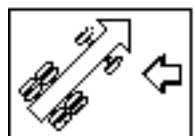
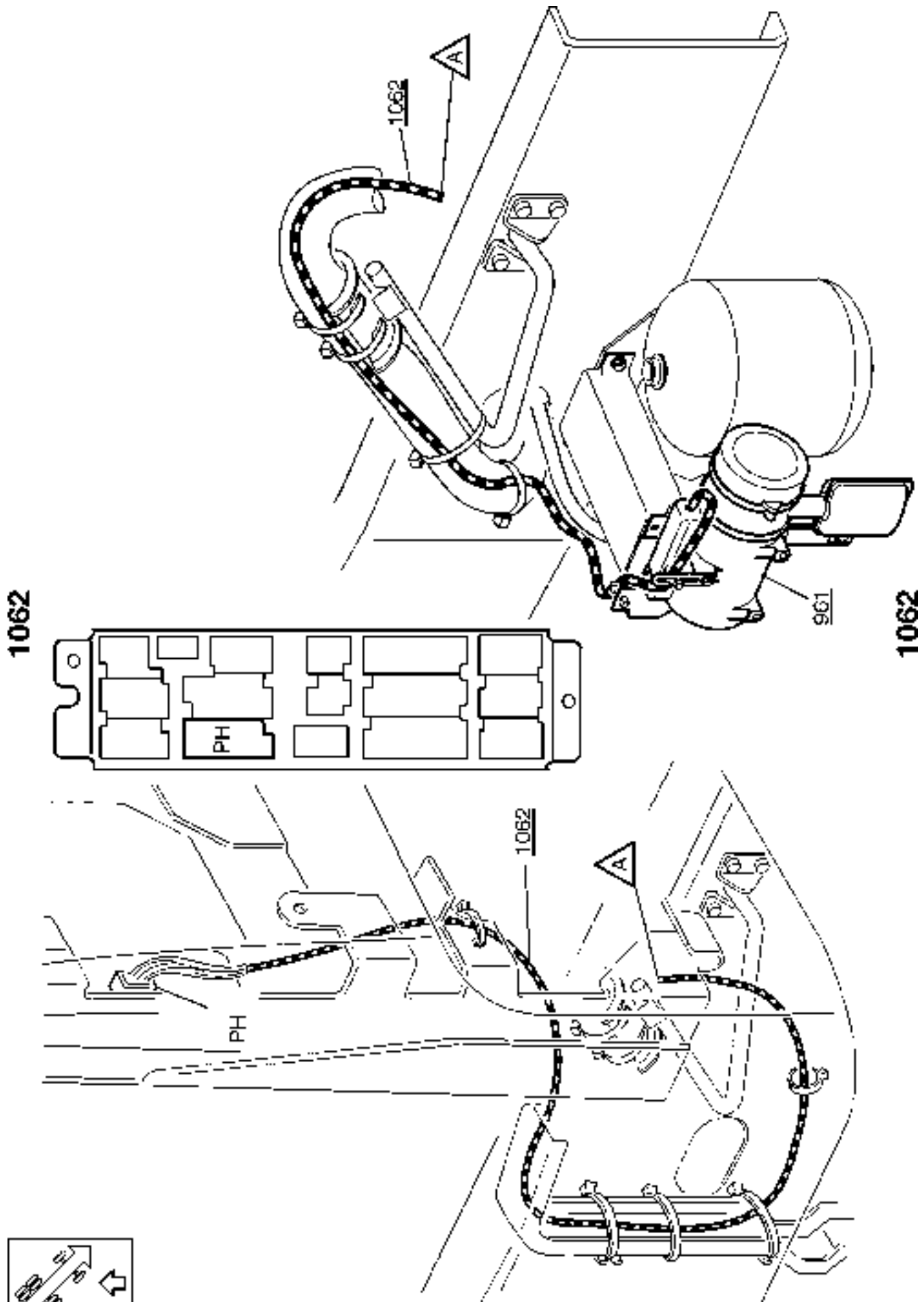

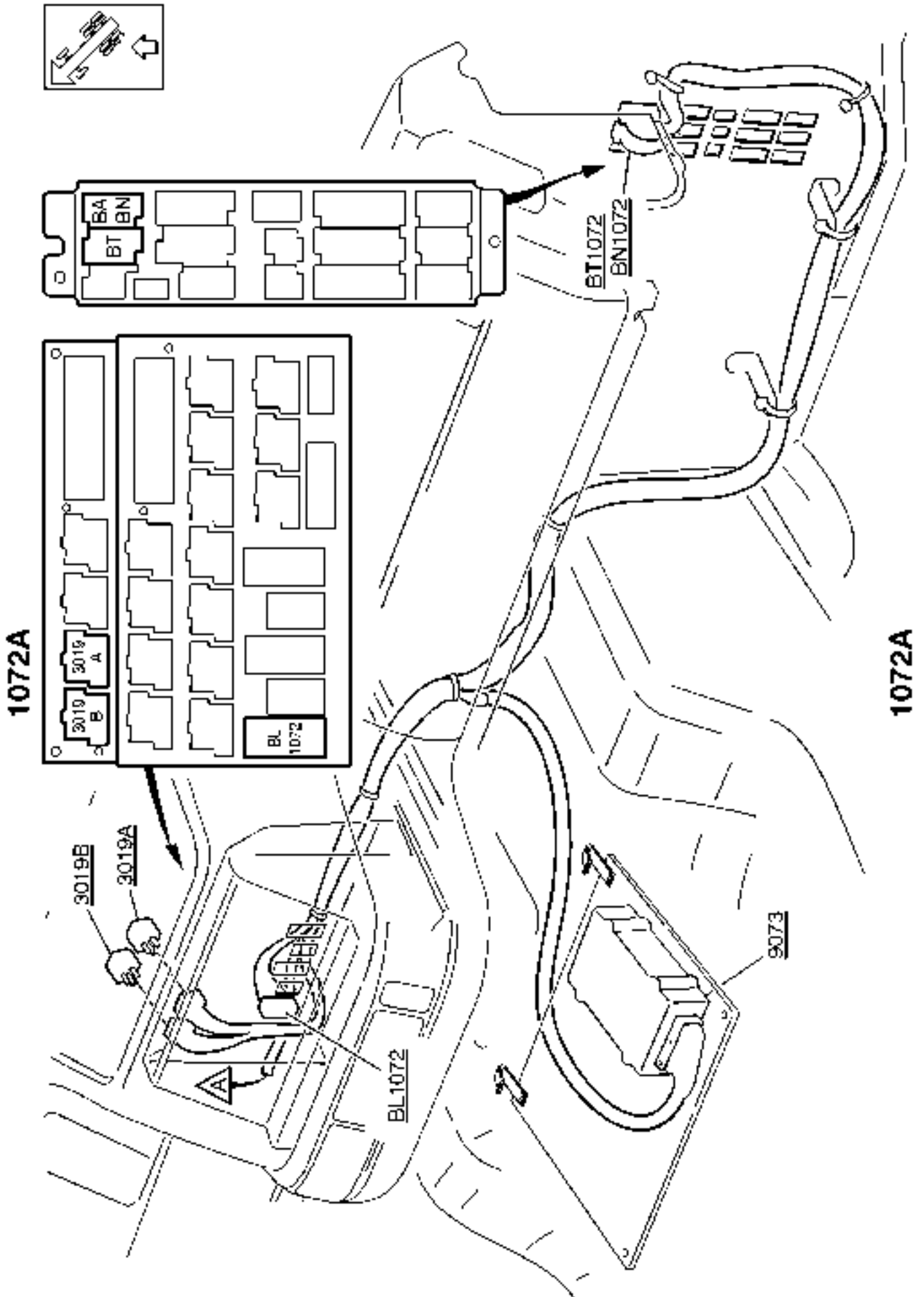

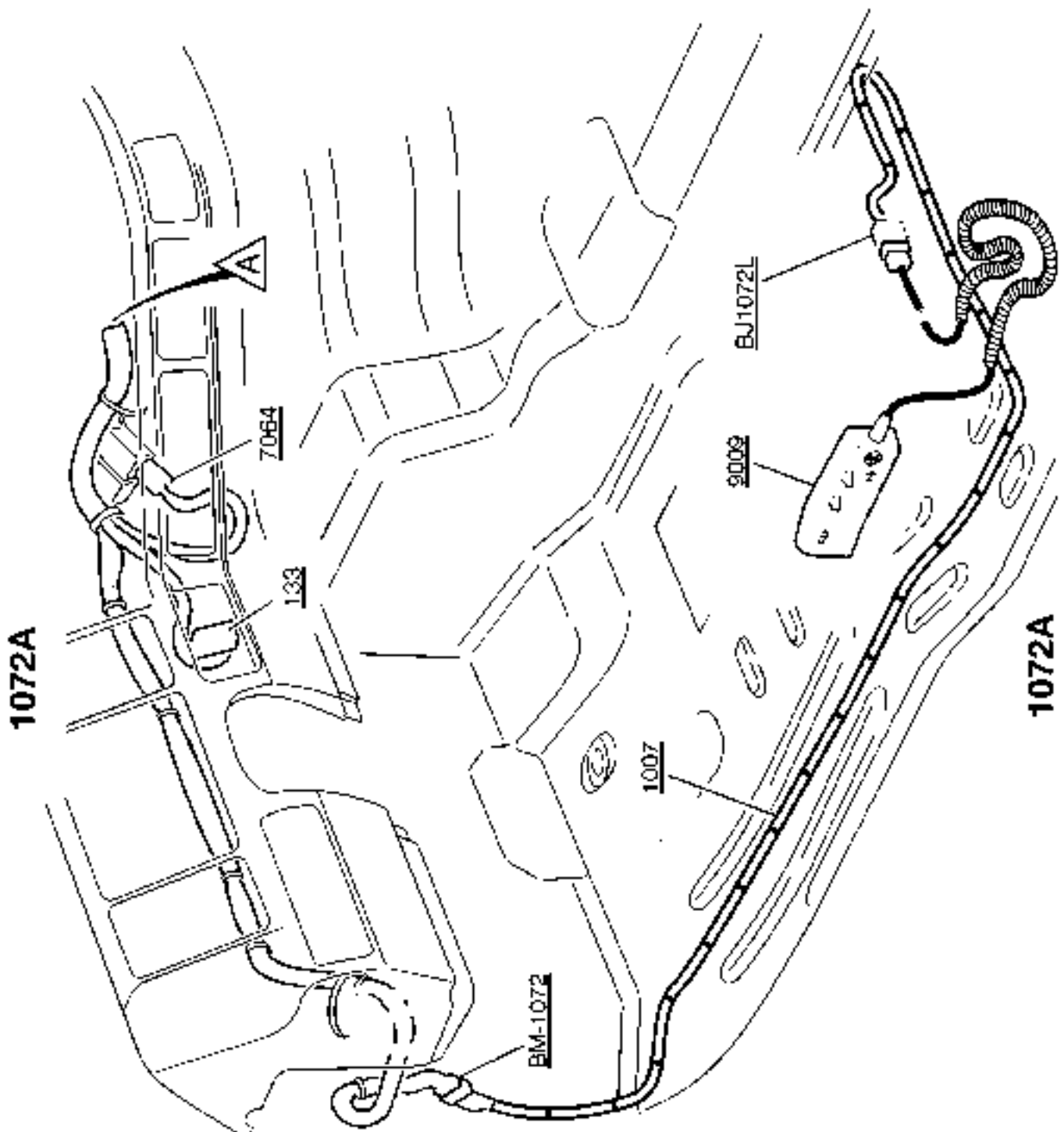
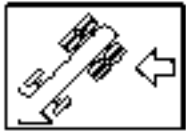



1072D

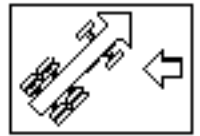
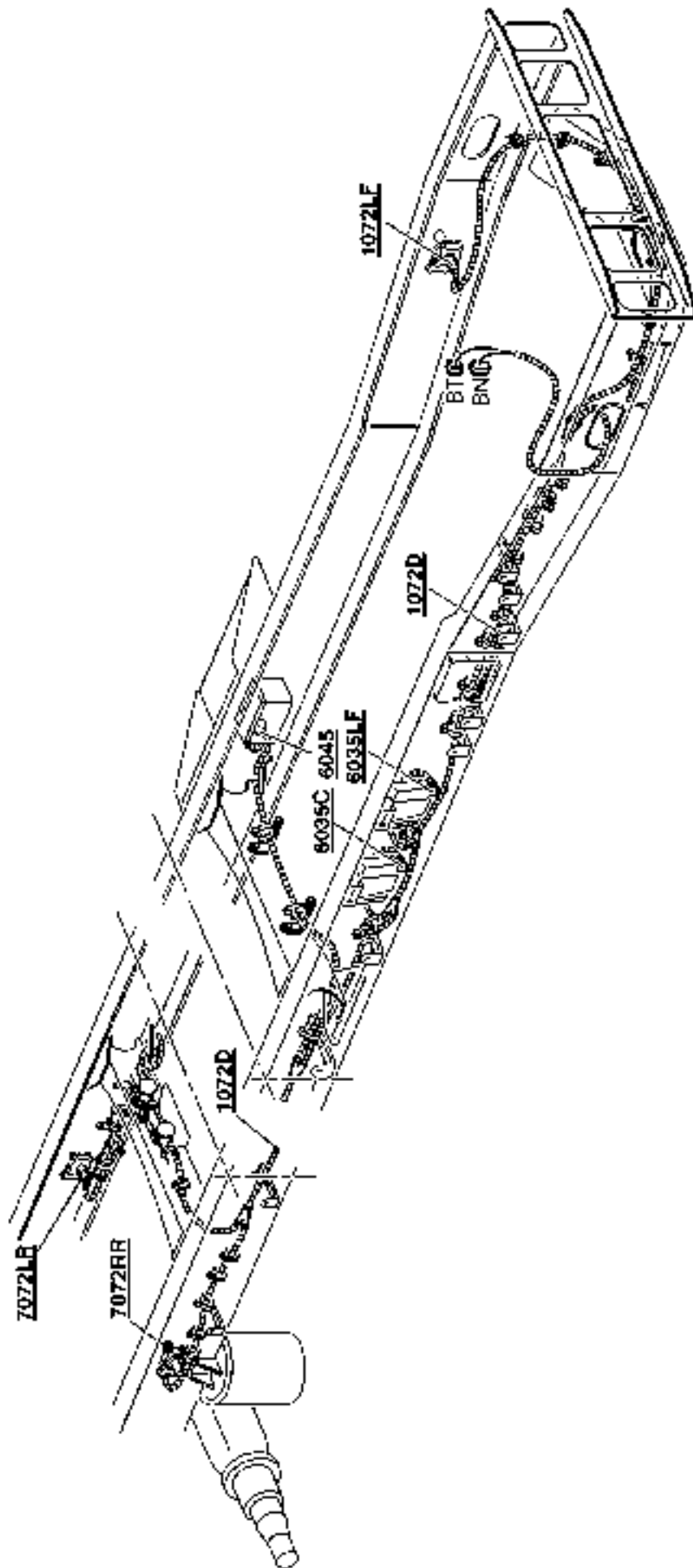

1072D



1074B,1097

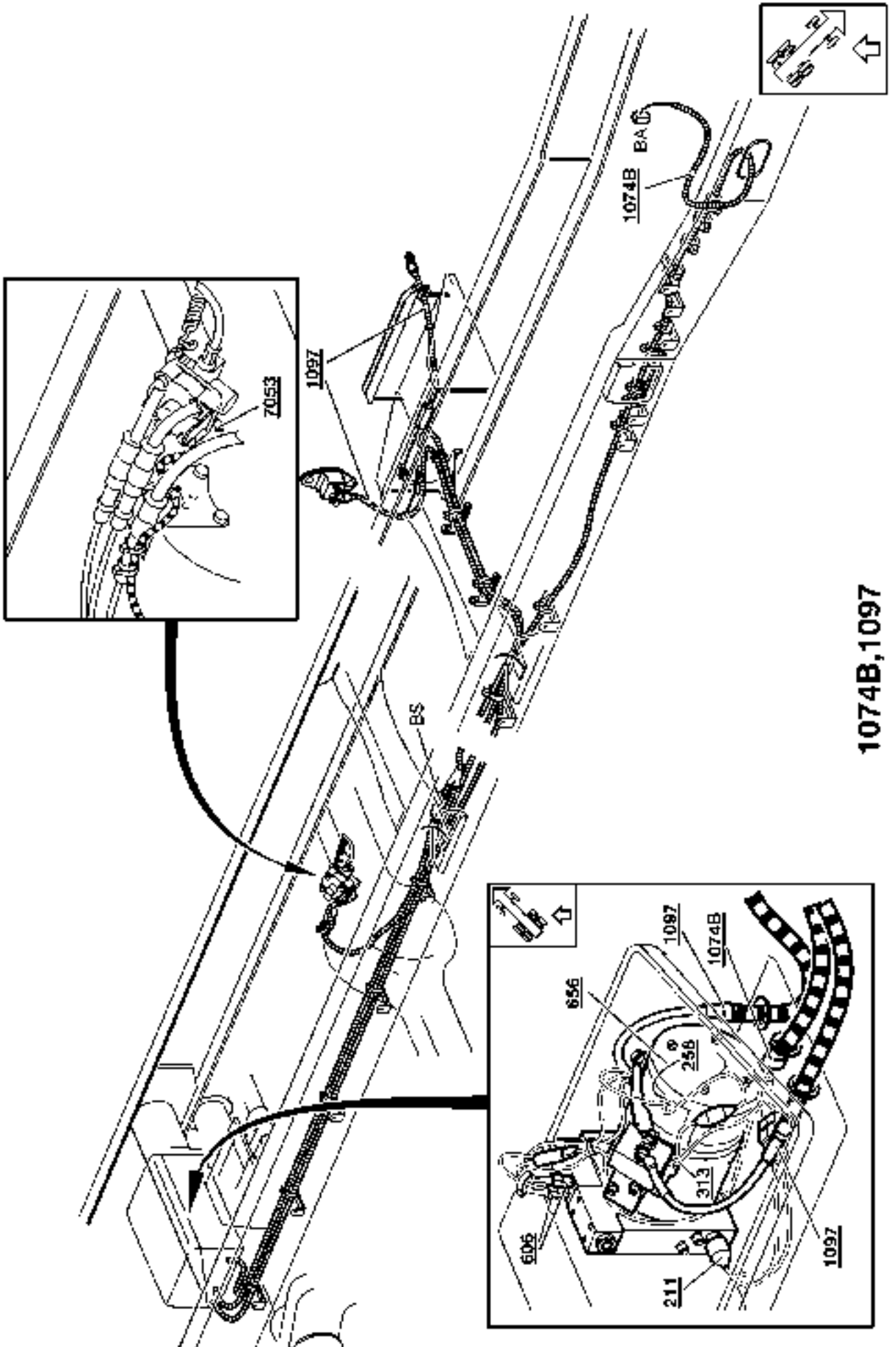

1074B,1097

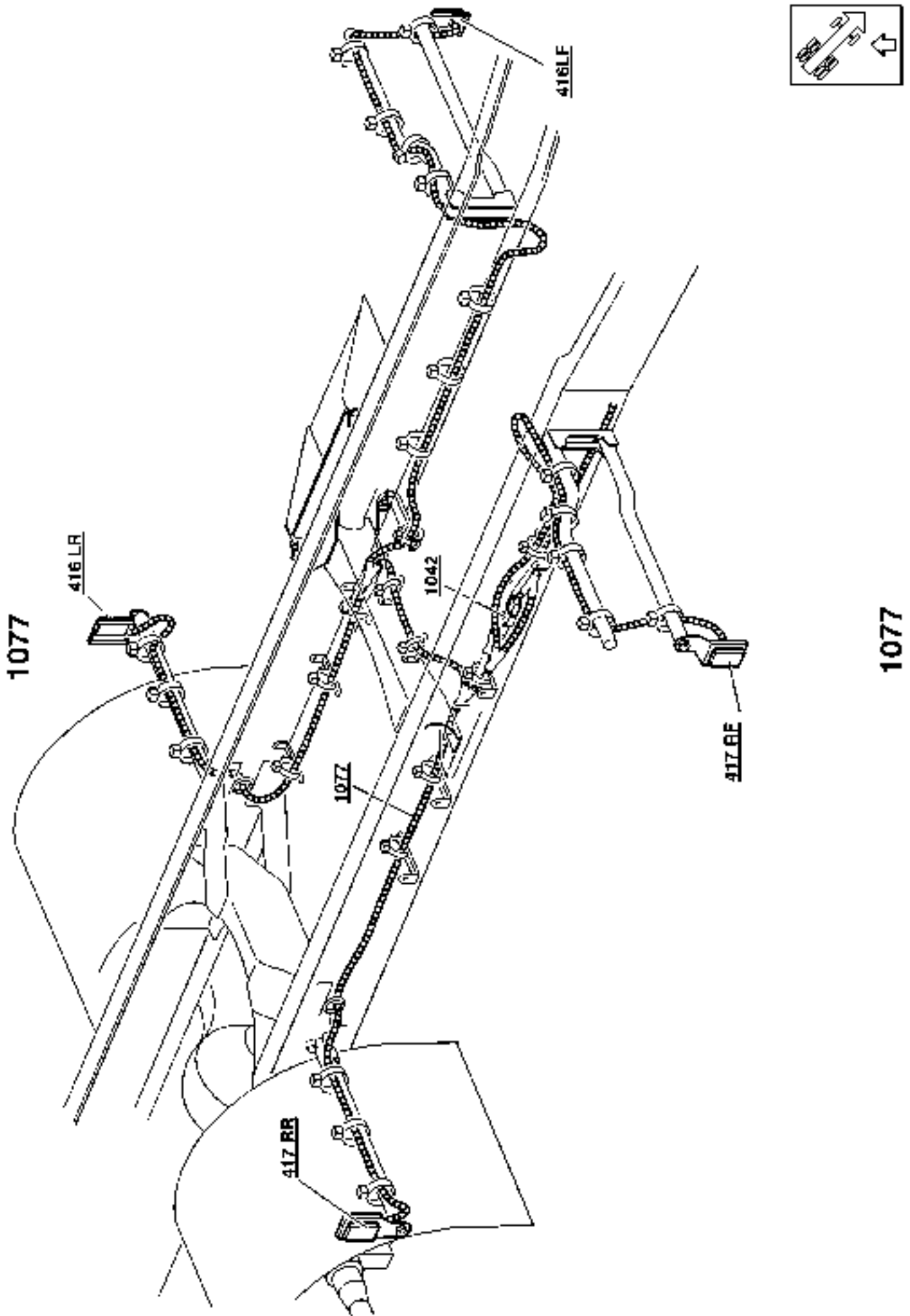

**1083, WLIFT-ME, LOCK-MAN, UMIR-AUX**

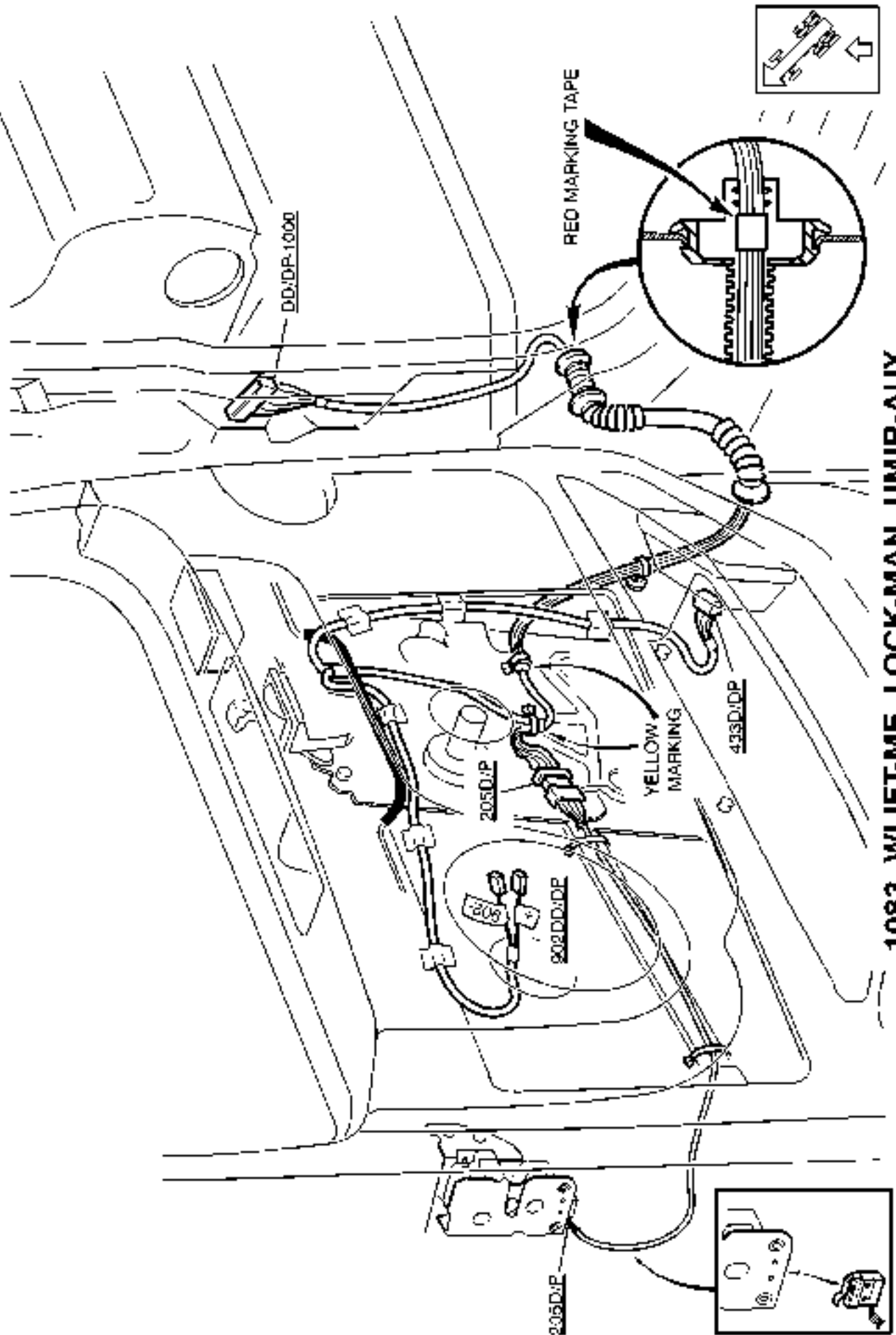

**1083, WLIFT-ME, LOCK-MAN, UMIR-AUX**



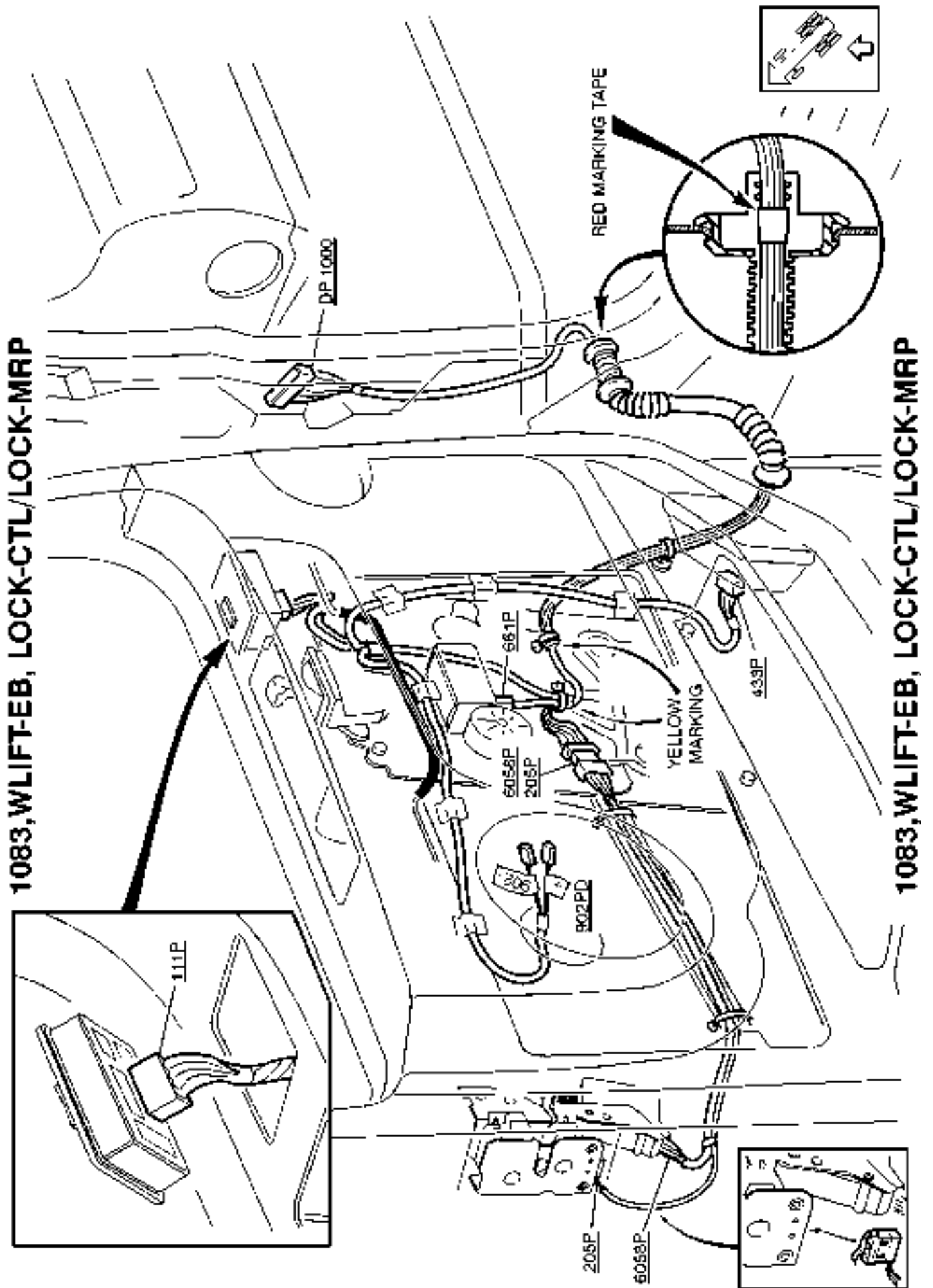

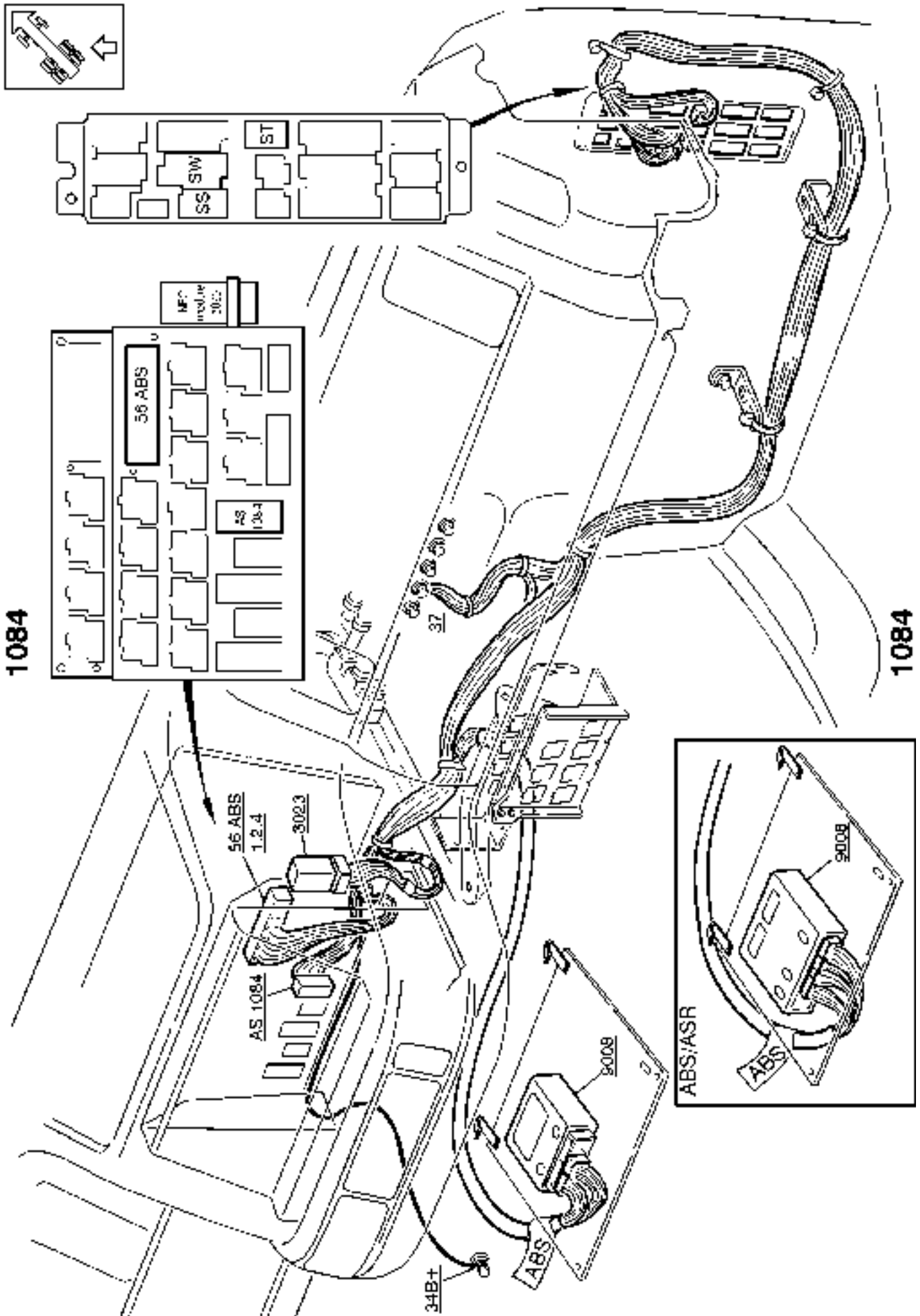



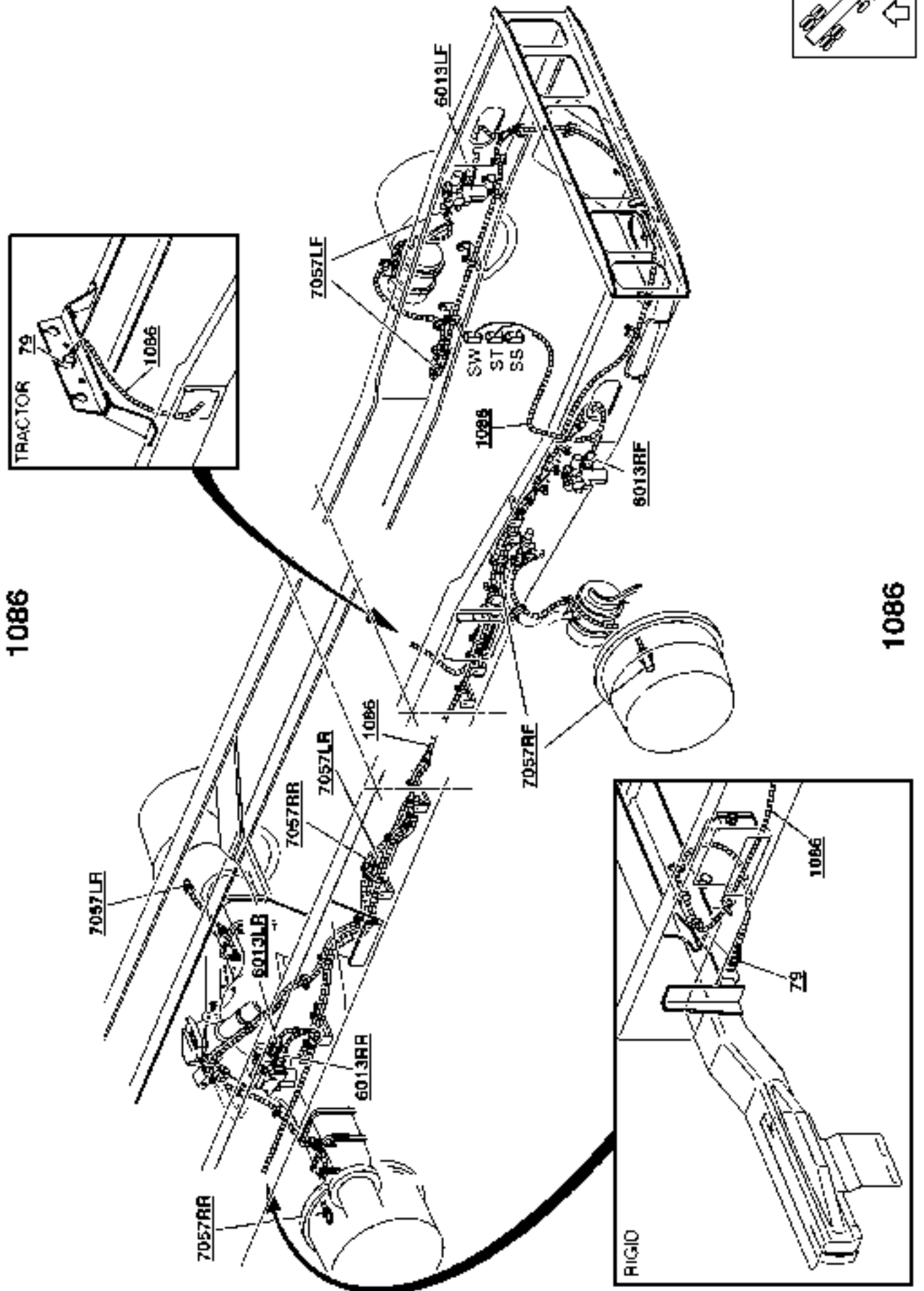
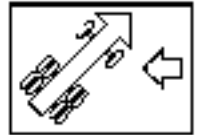

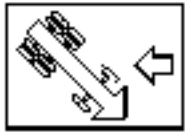

650/1402

650/1402

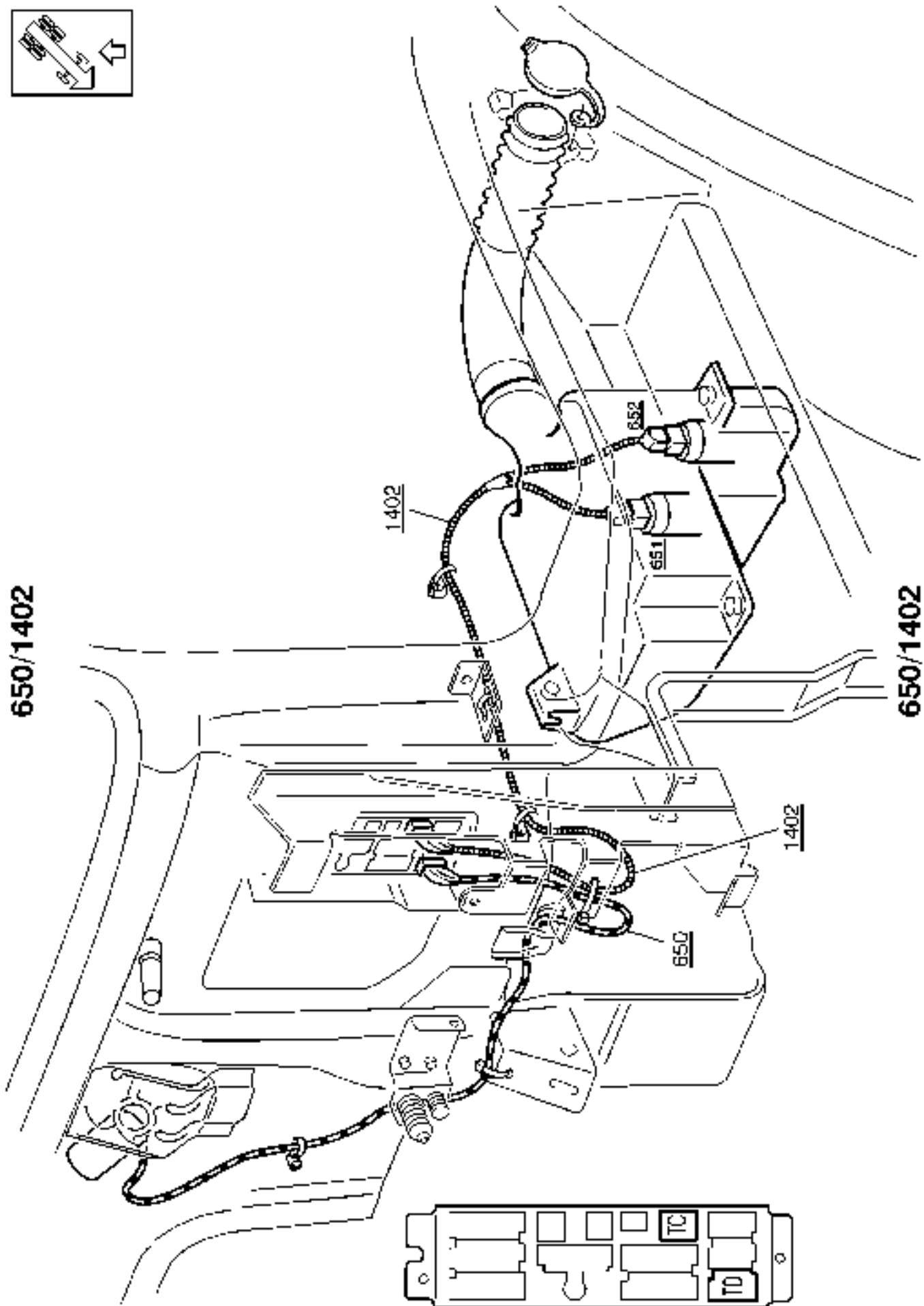

1404

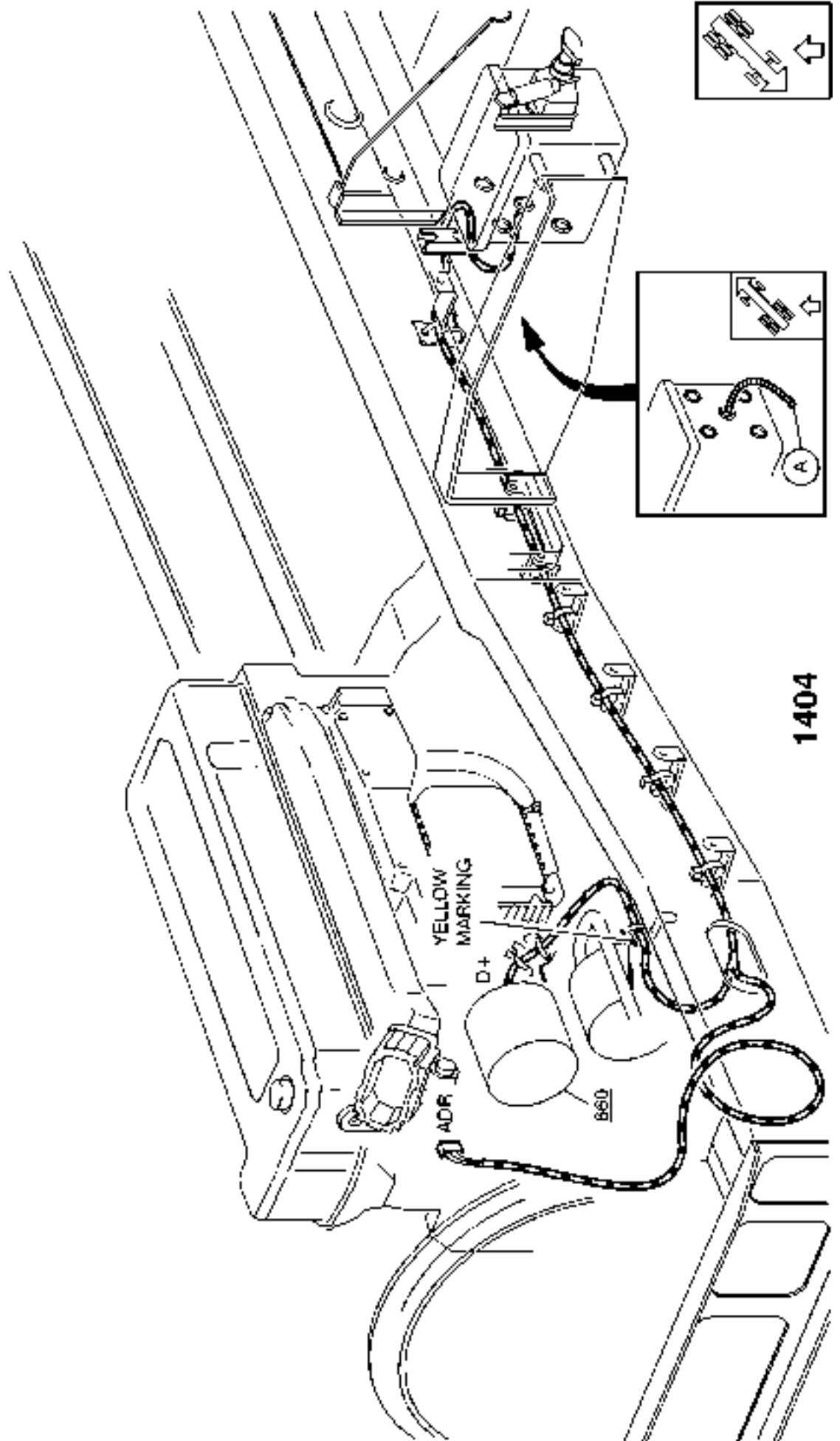

1404

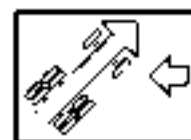

# ADR-FRA, PH-CAB

1404

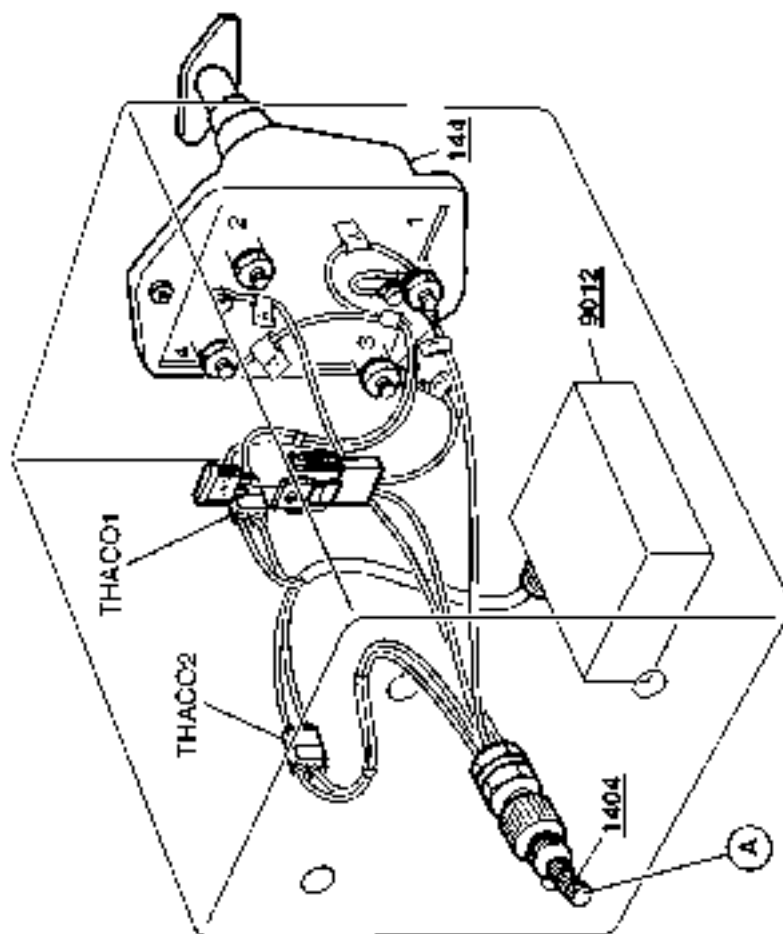

1404

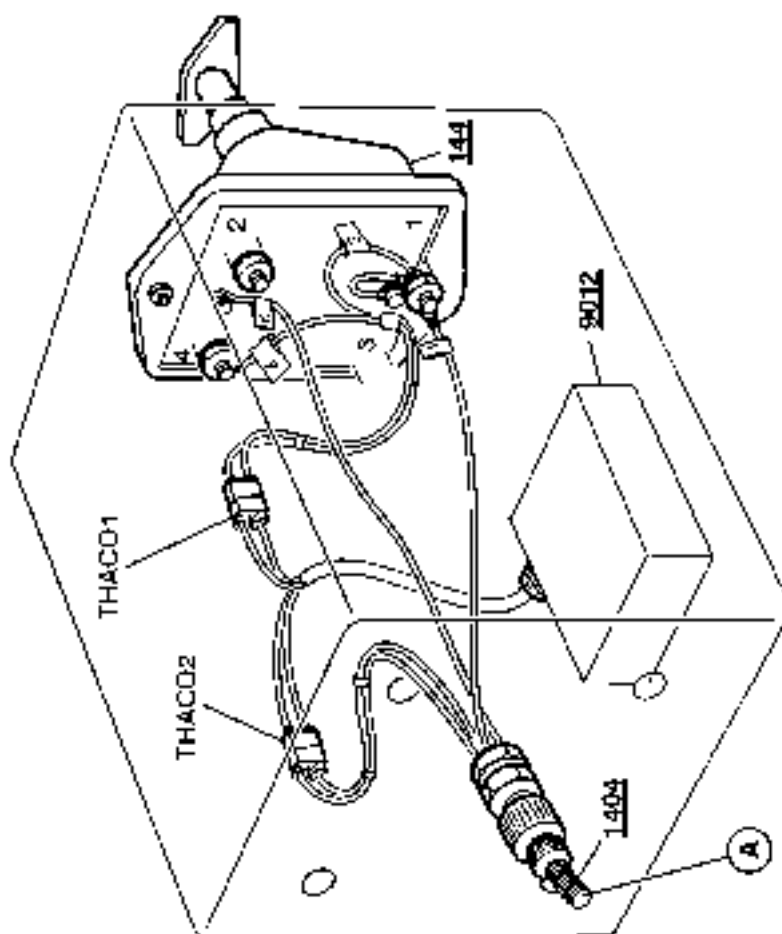

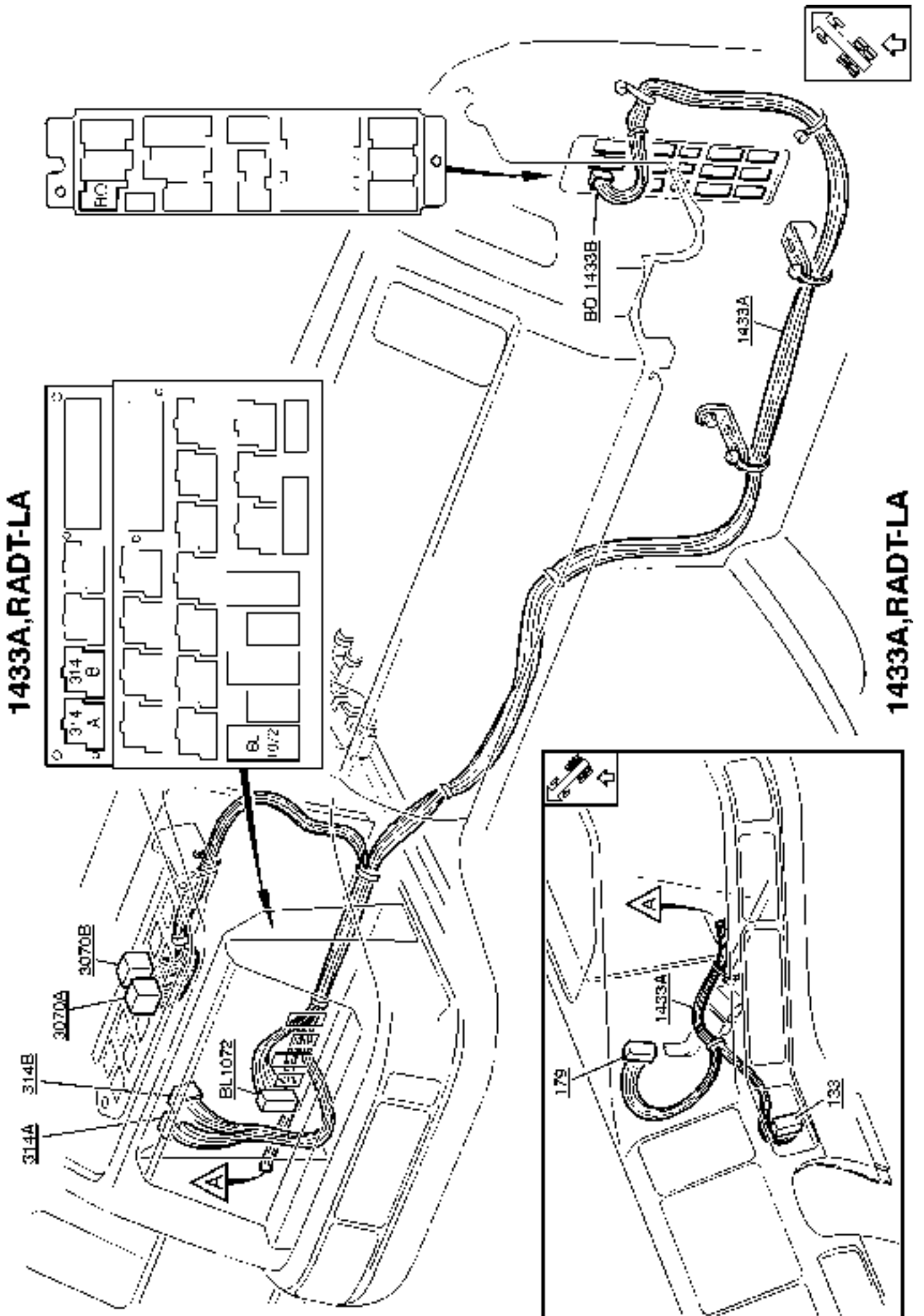

**1433A, RADT-A6S**

**1433A, RADT-A6S**

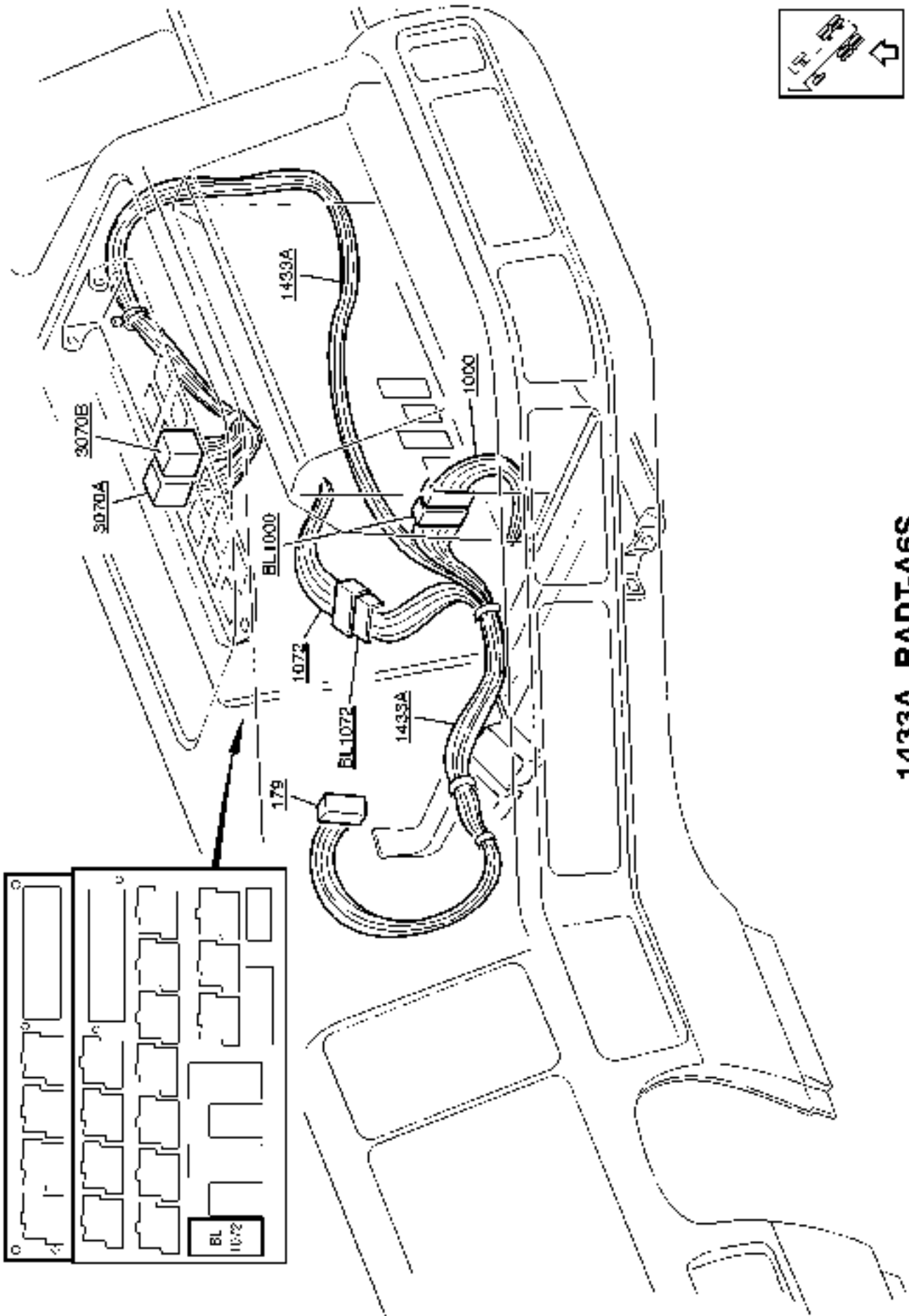

1433B

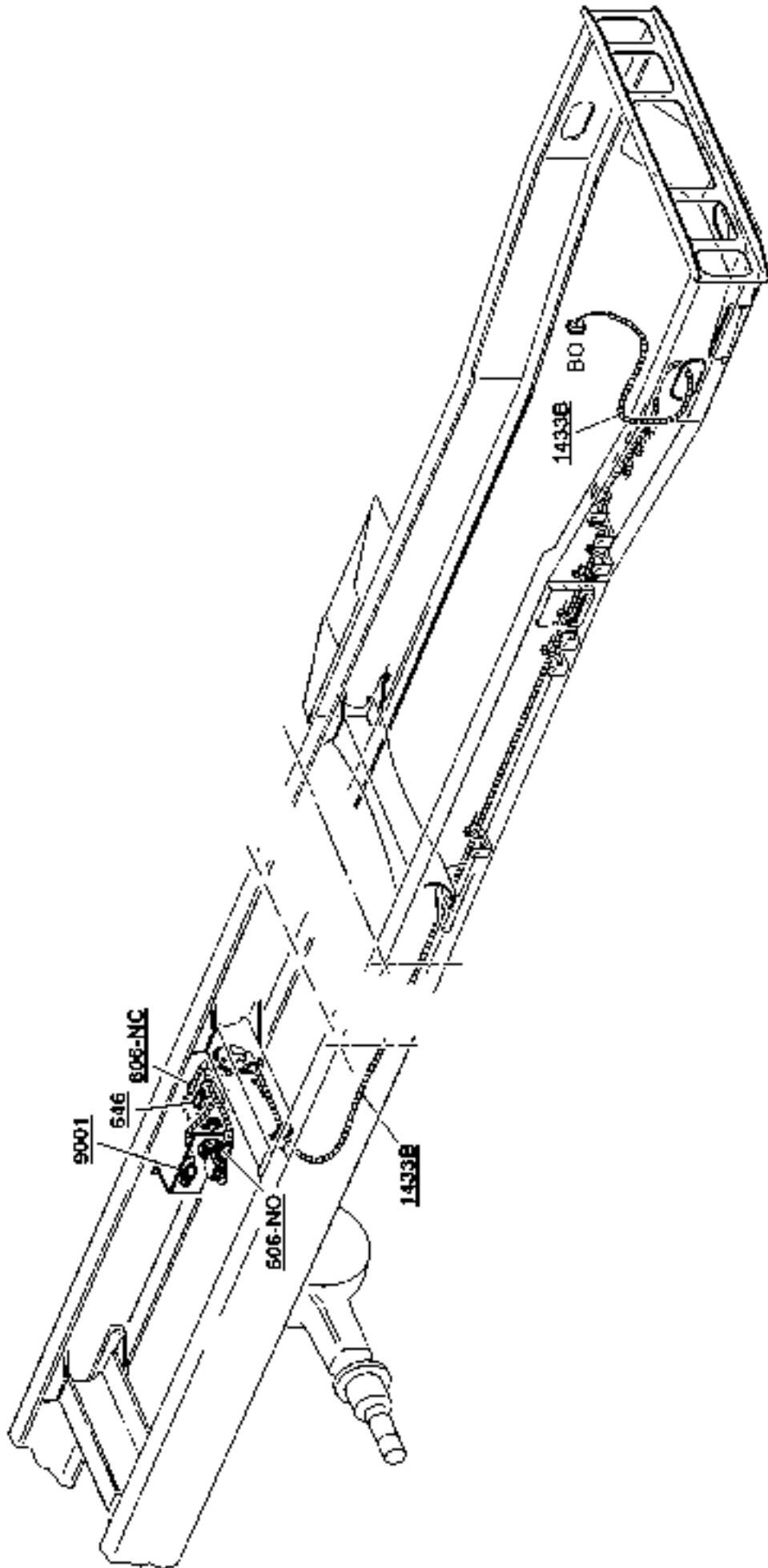

1433B

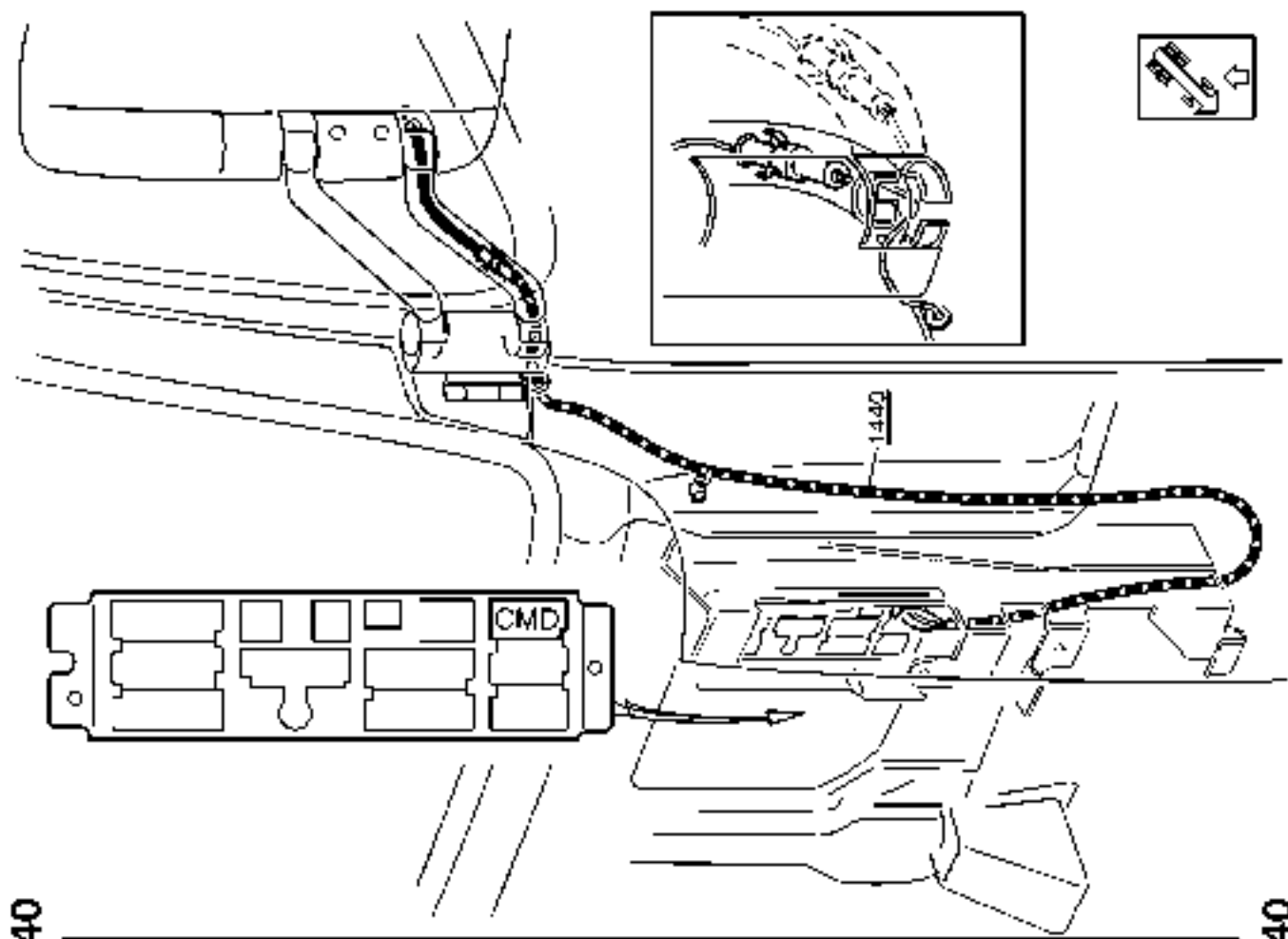

1440

1440

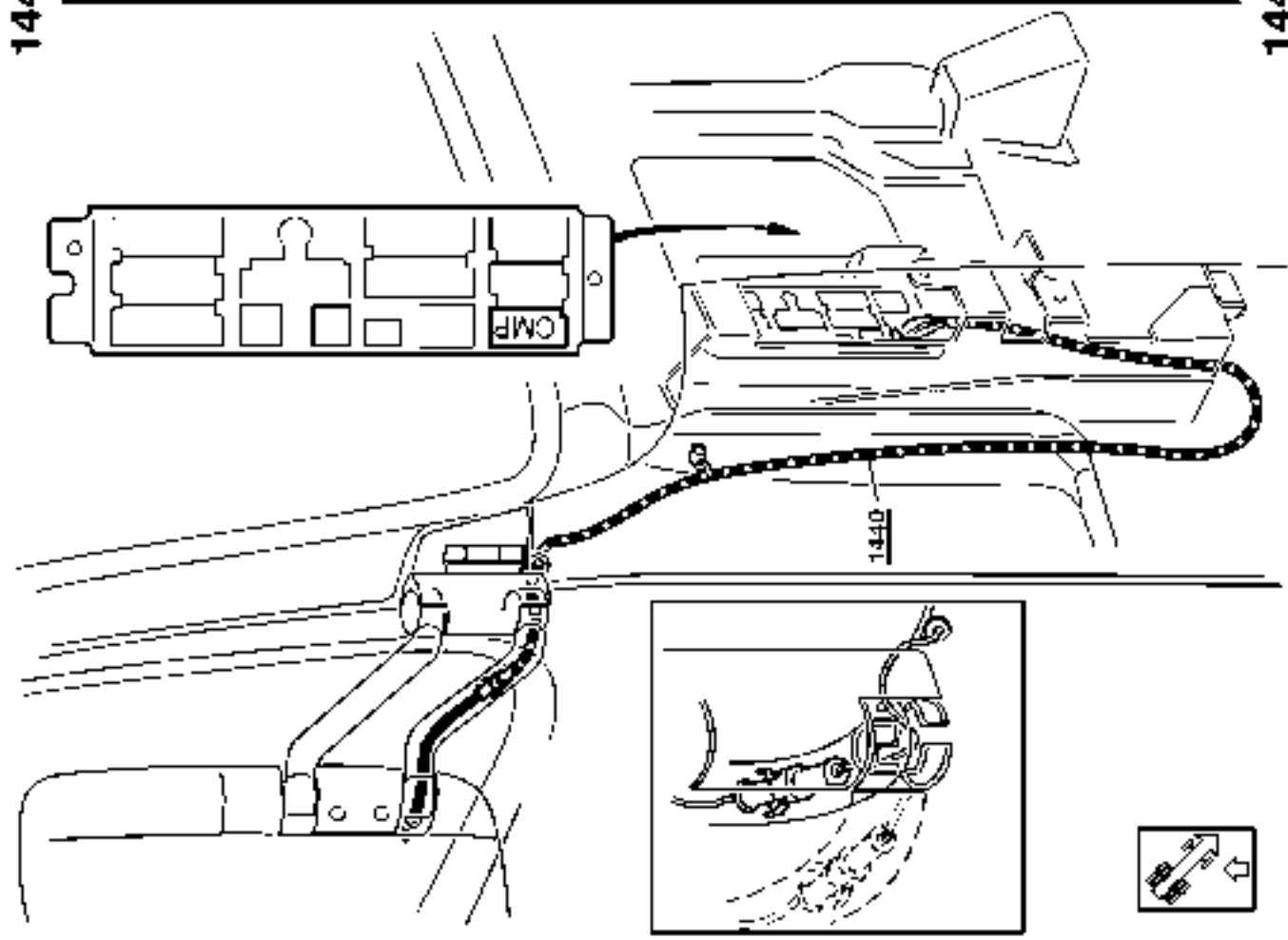



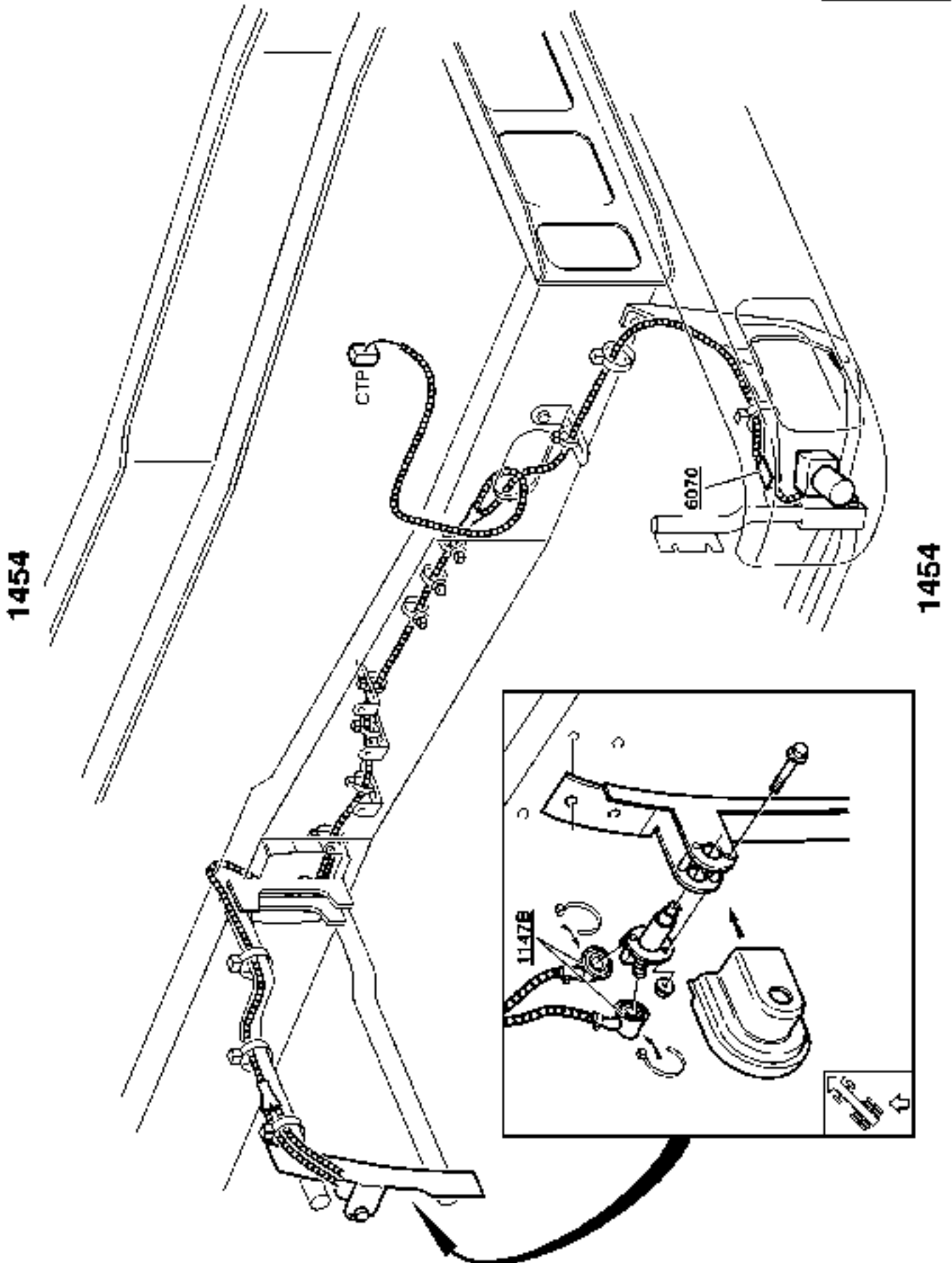
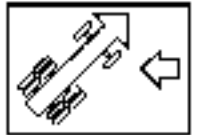

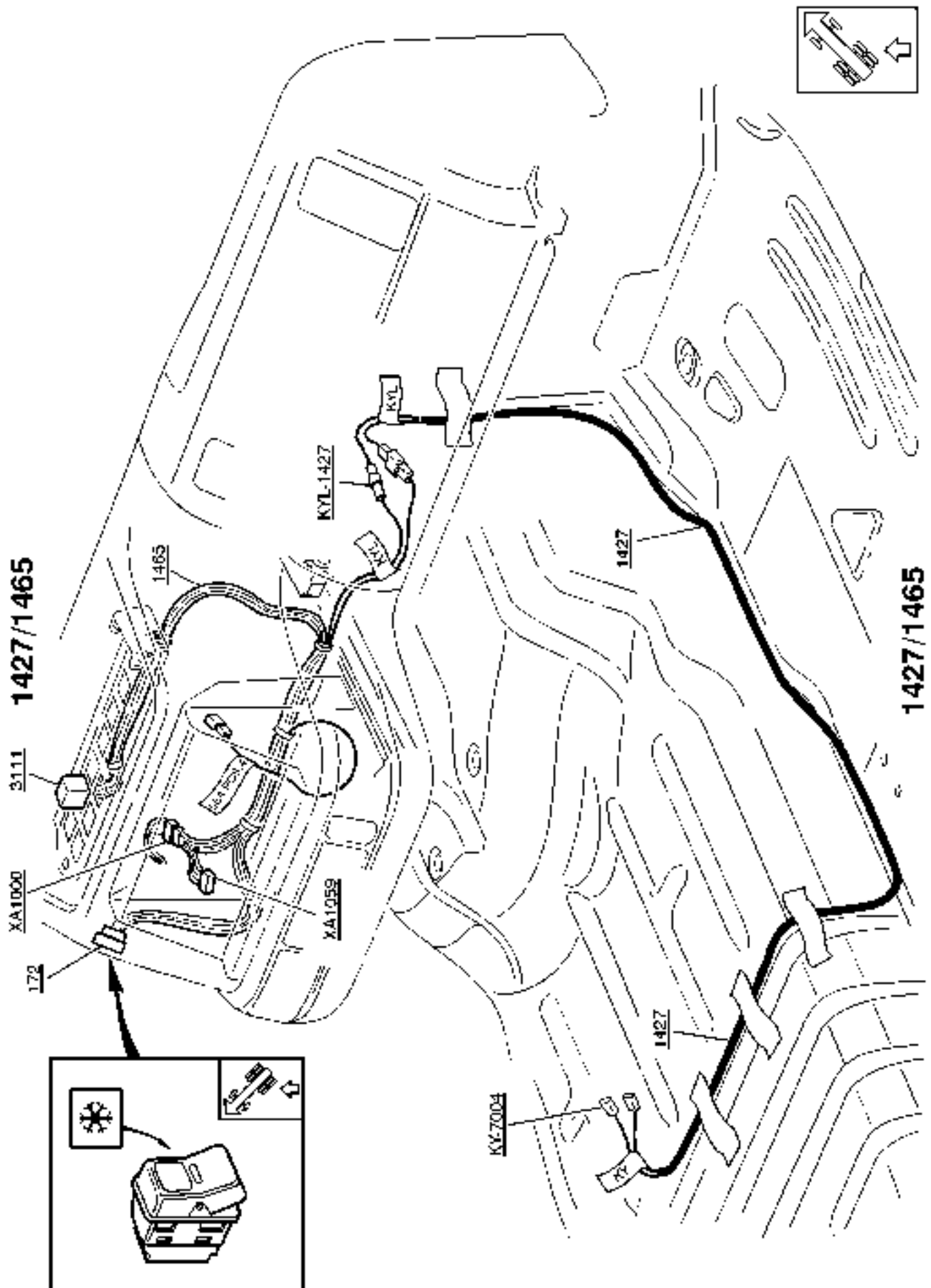

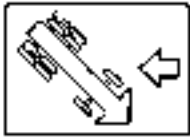

1468

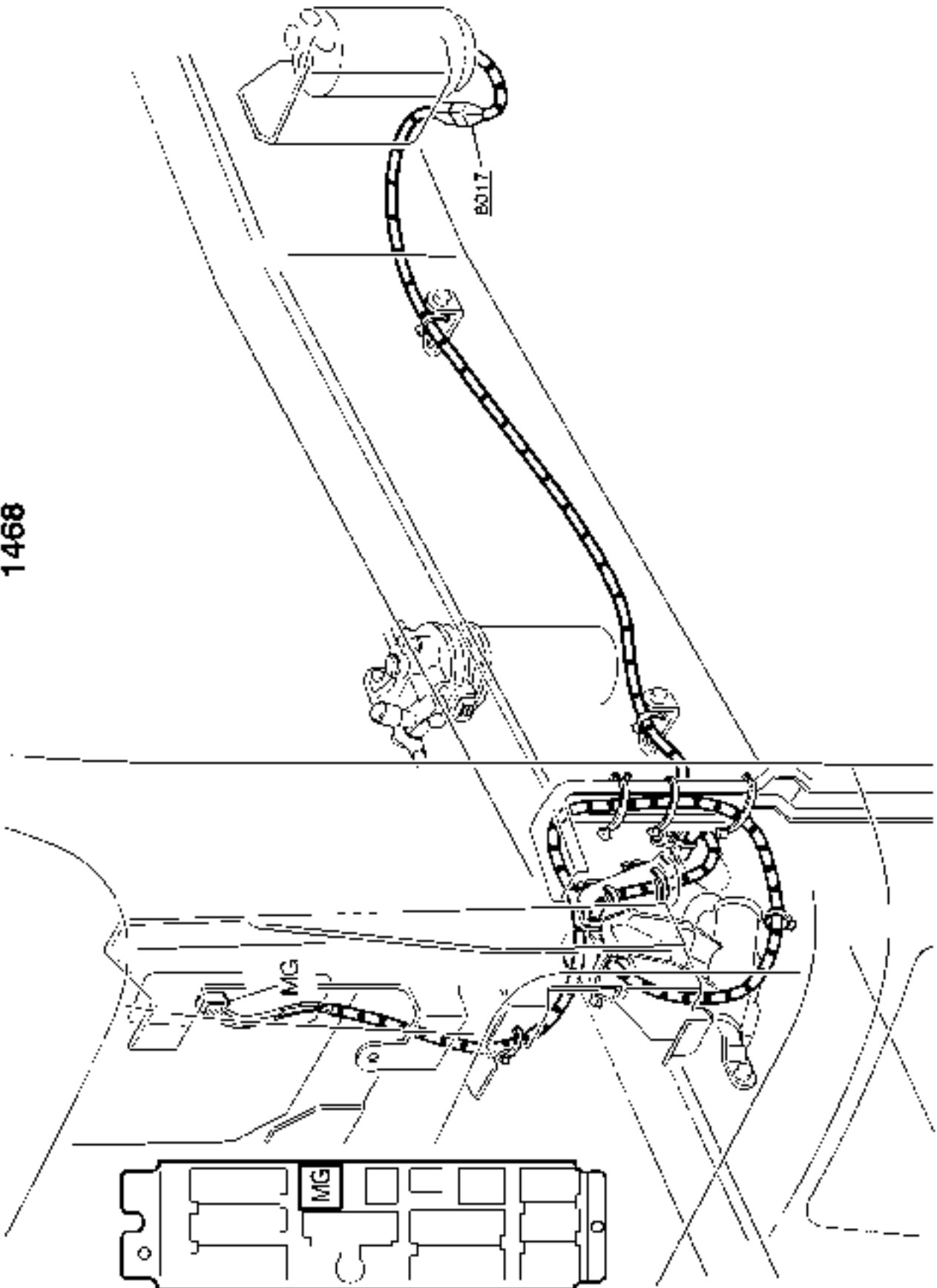

1468

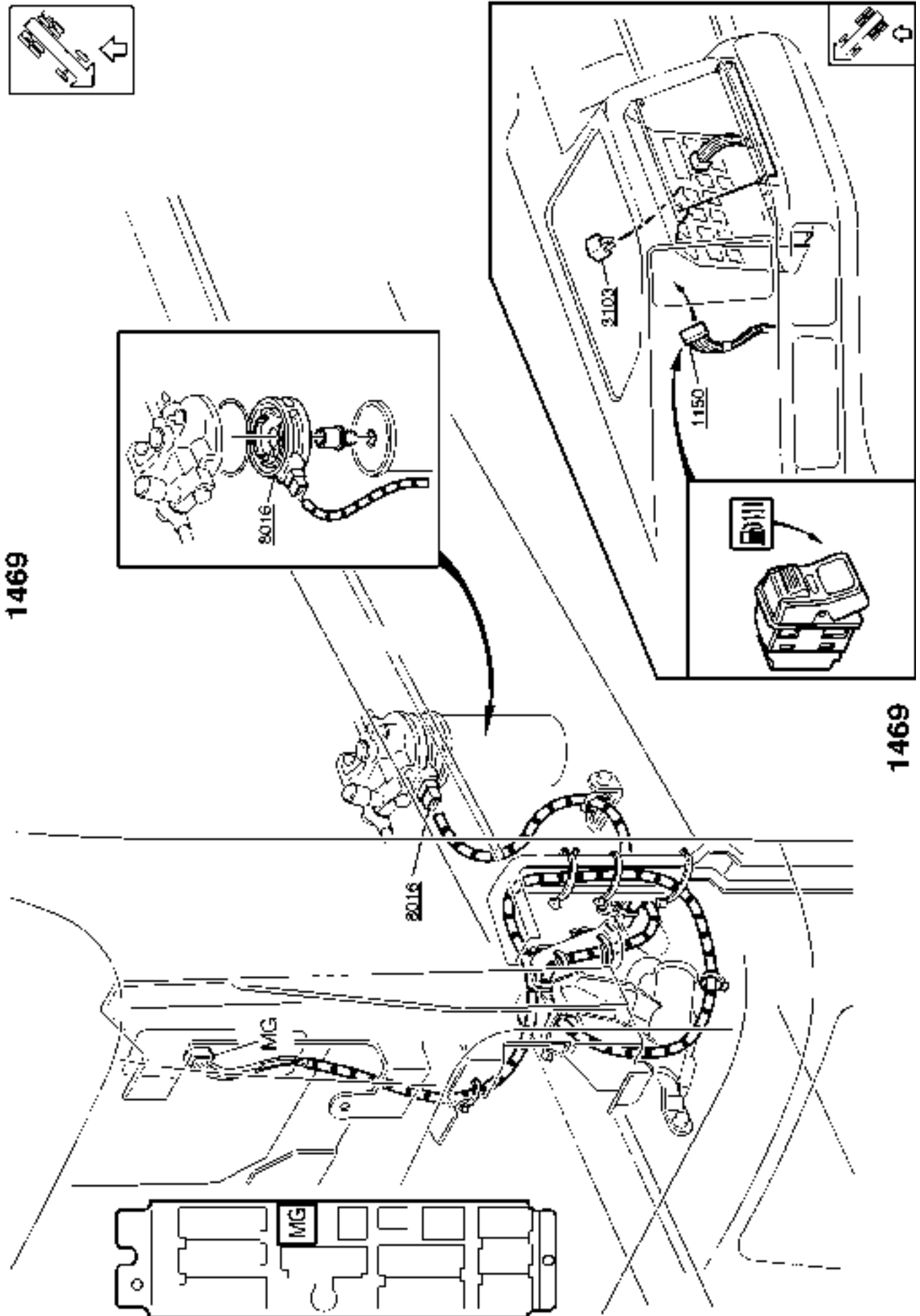

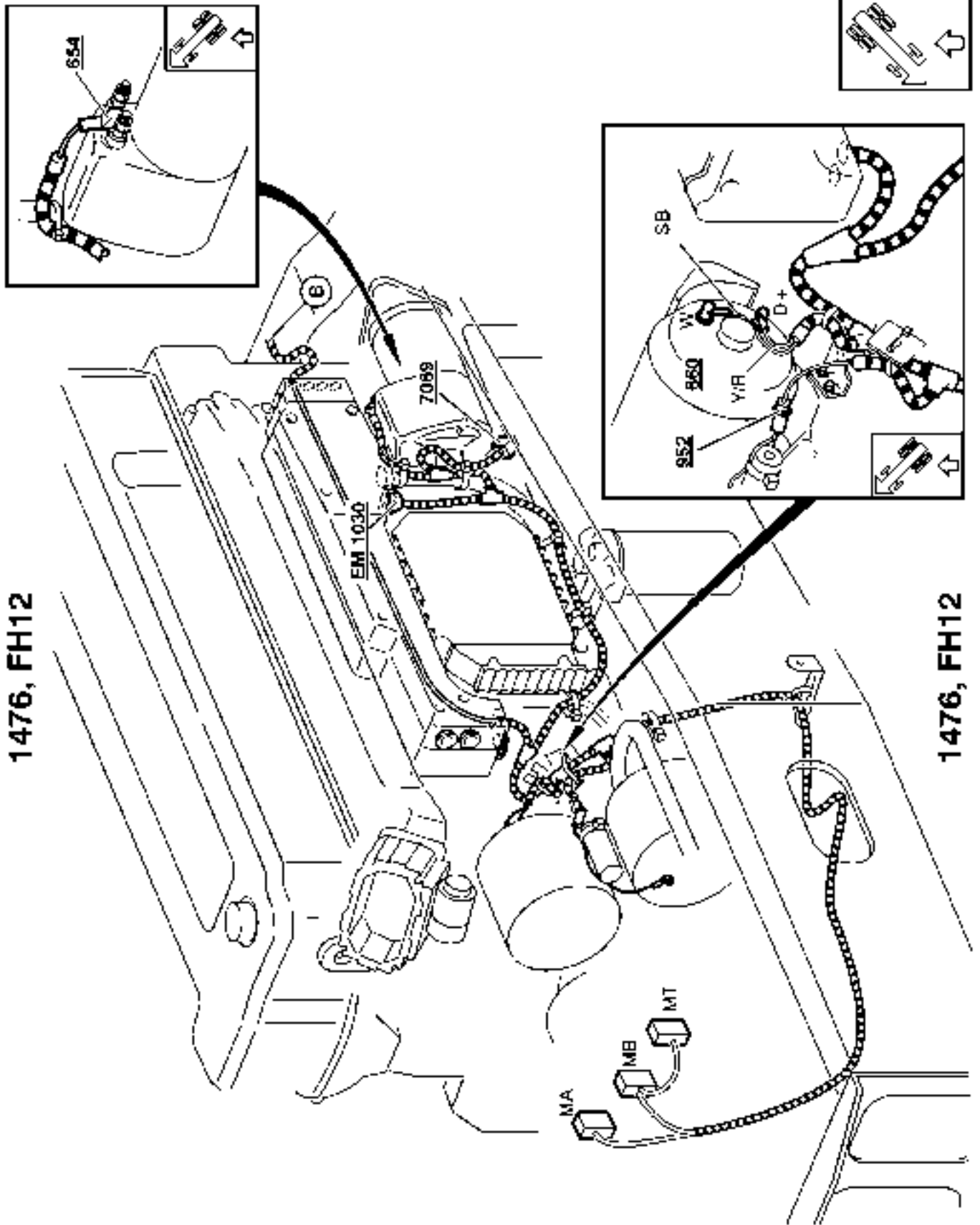

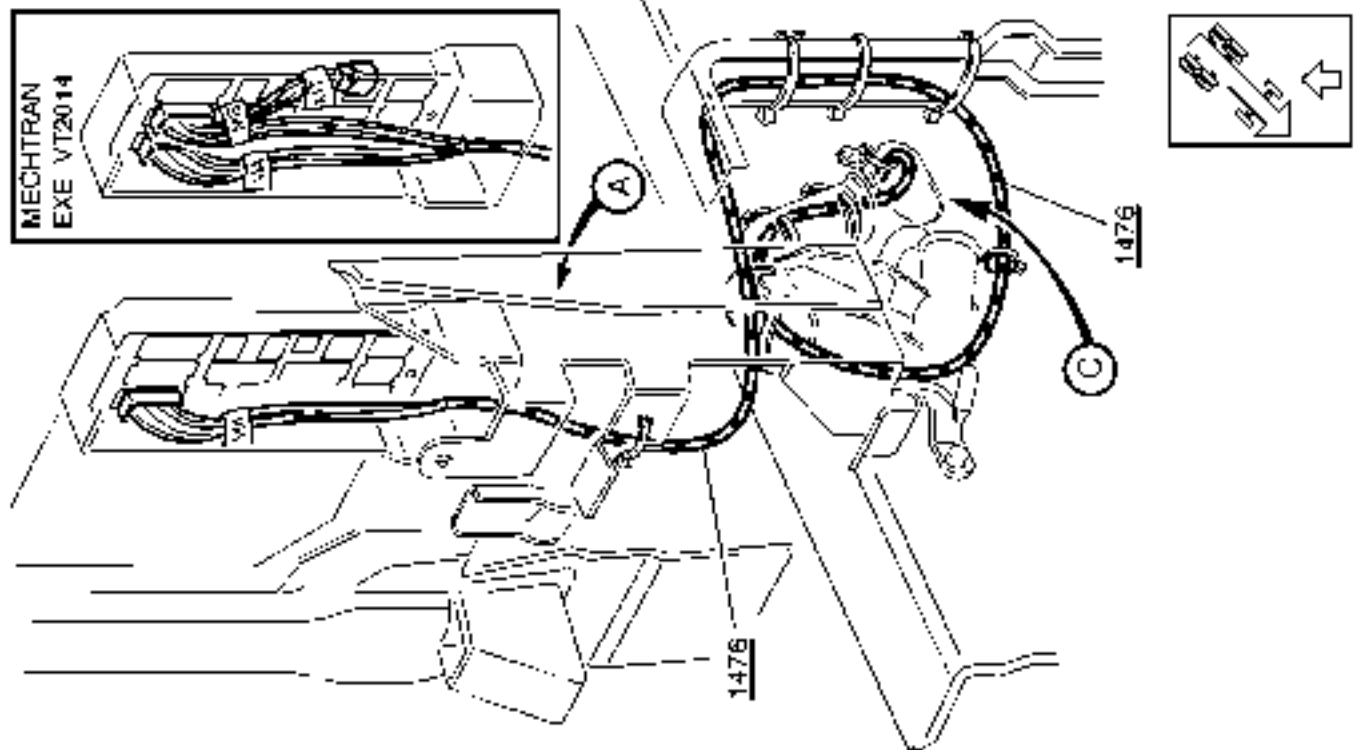

1476, FH16

1476, FH16

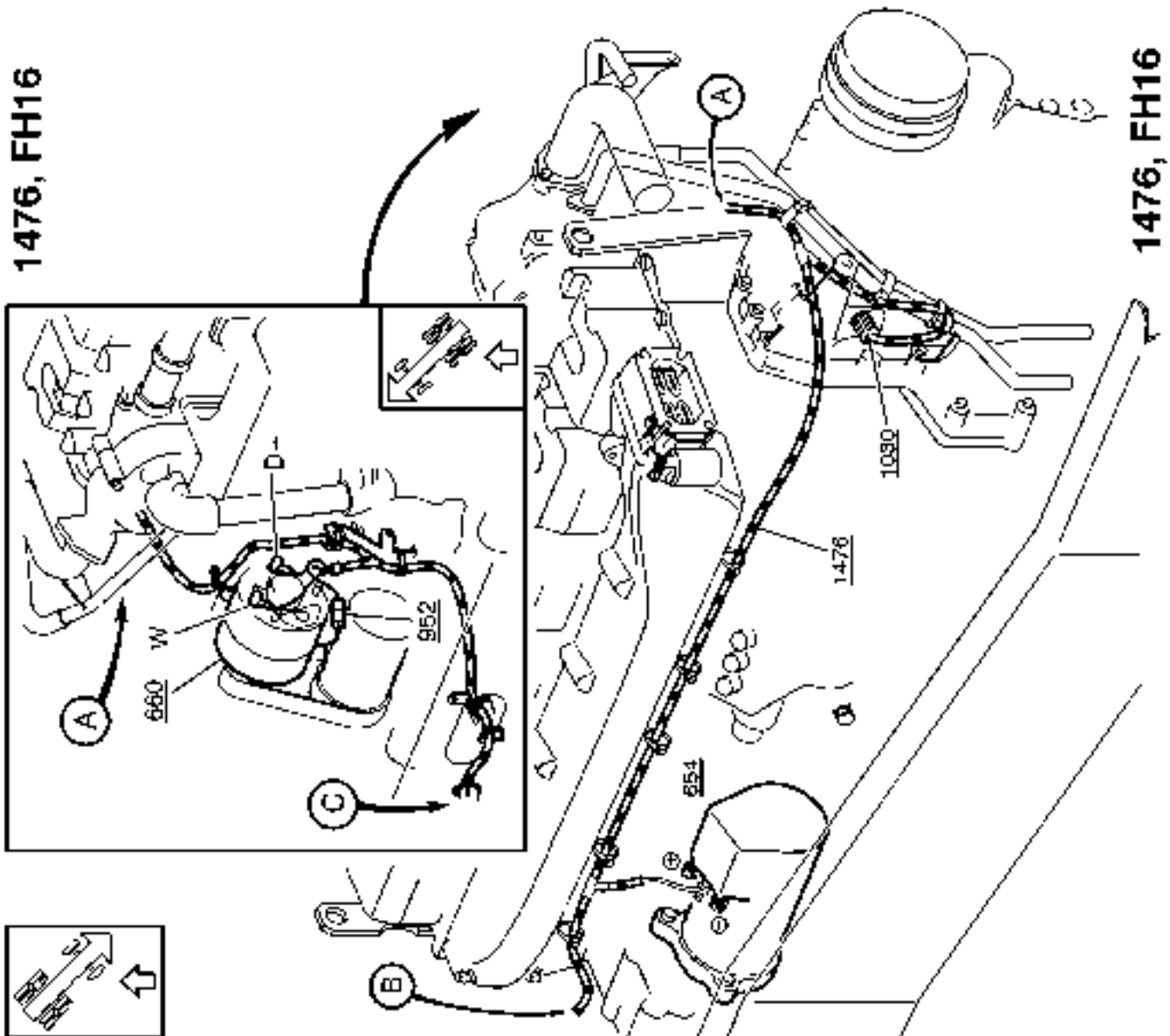

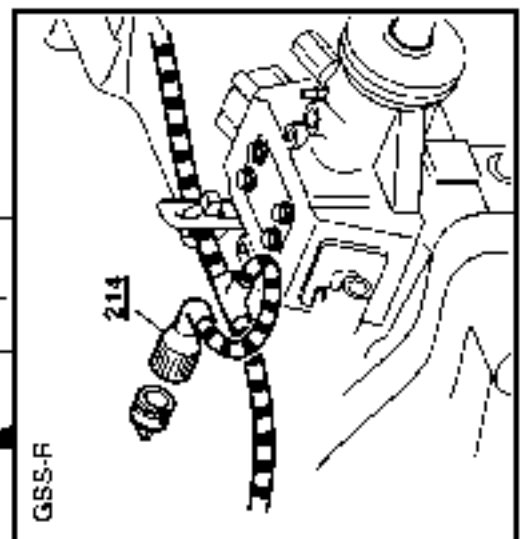
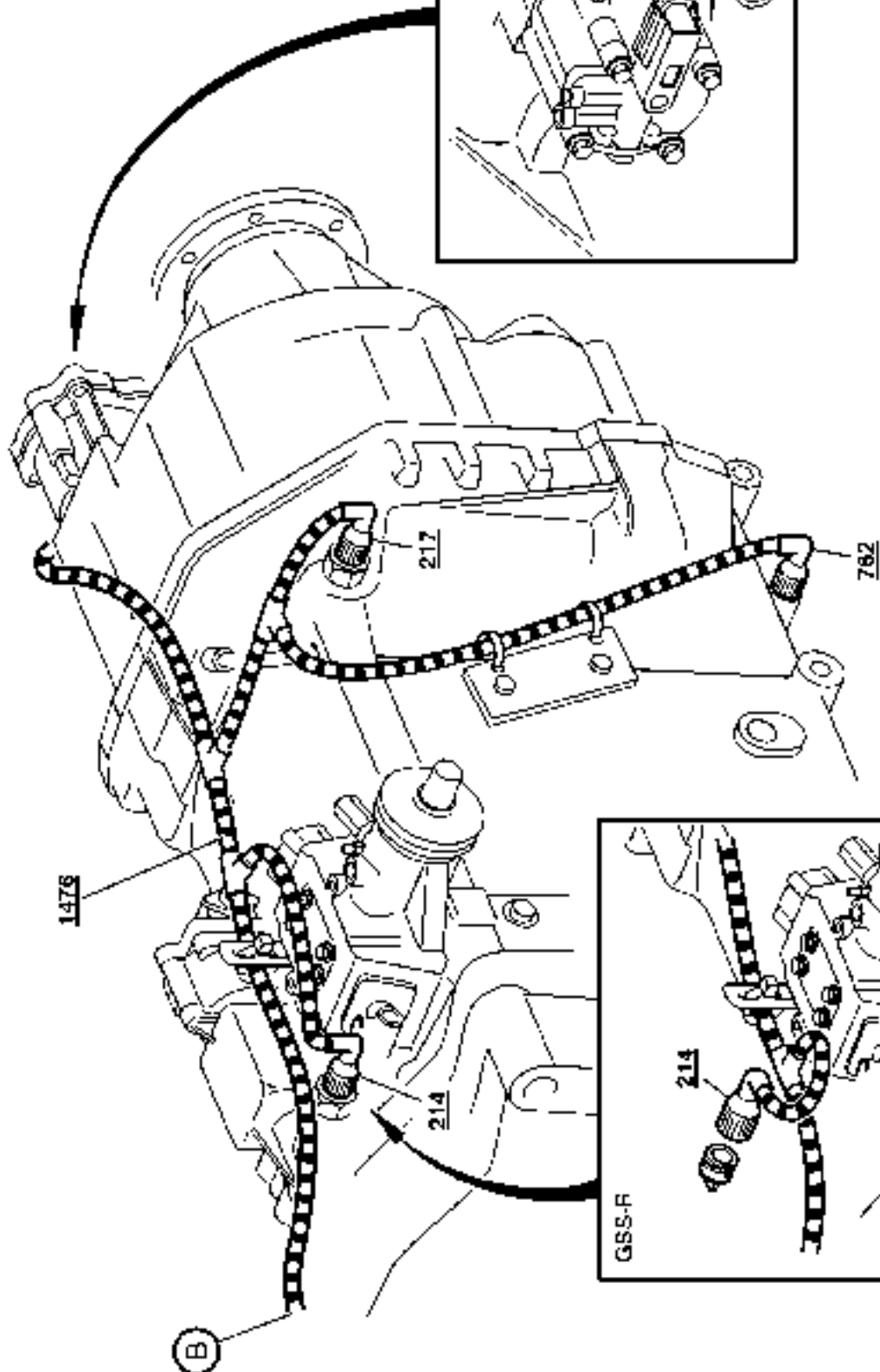
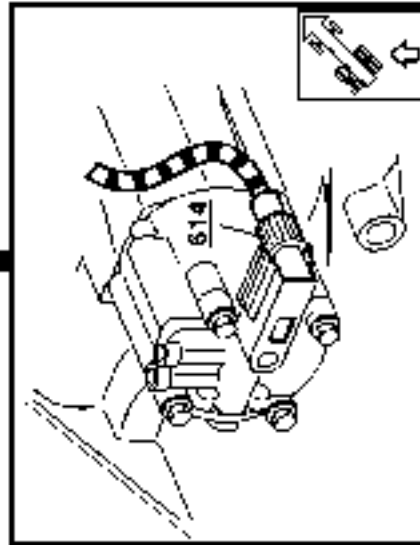
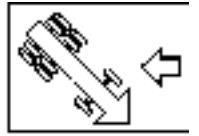

1476, VT2014

1476, VT2014

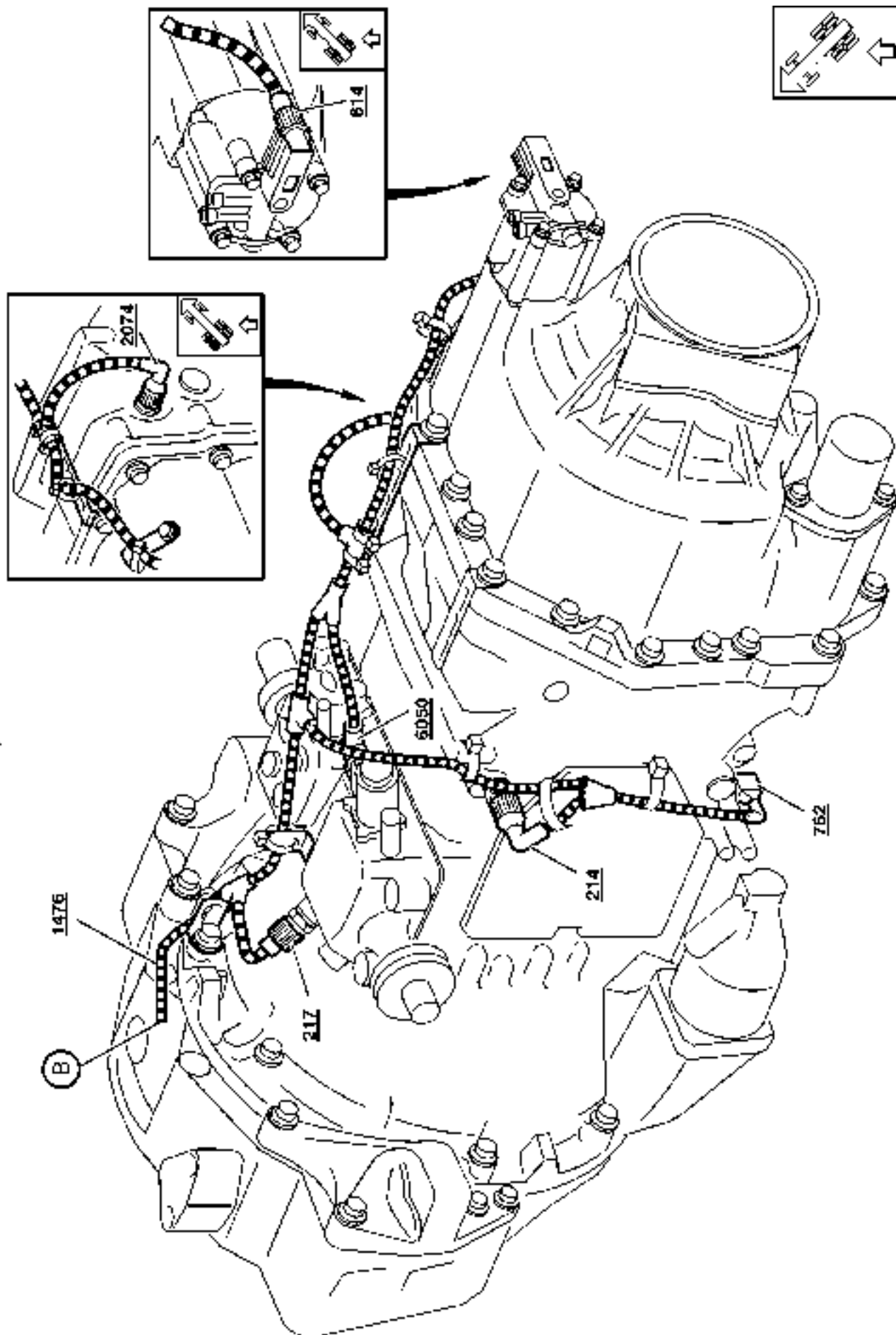



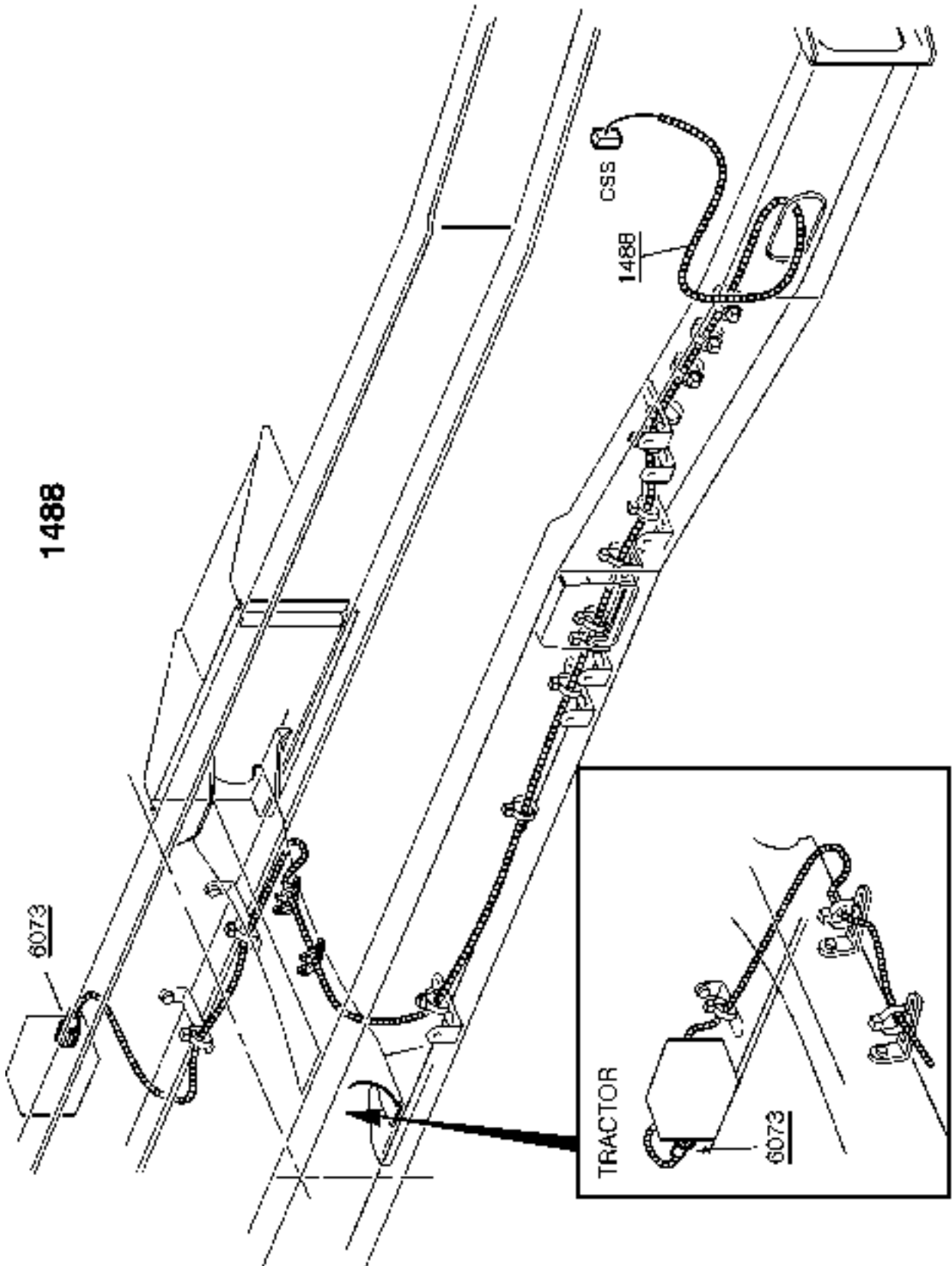
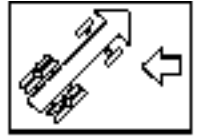

# Circuit card electrical centre

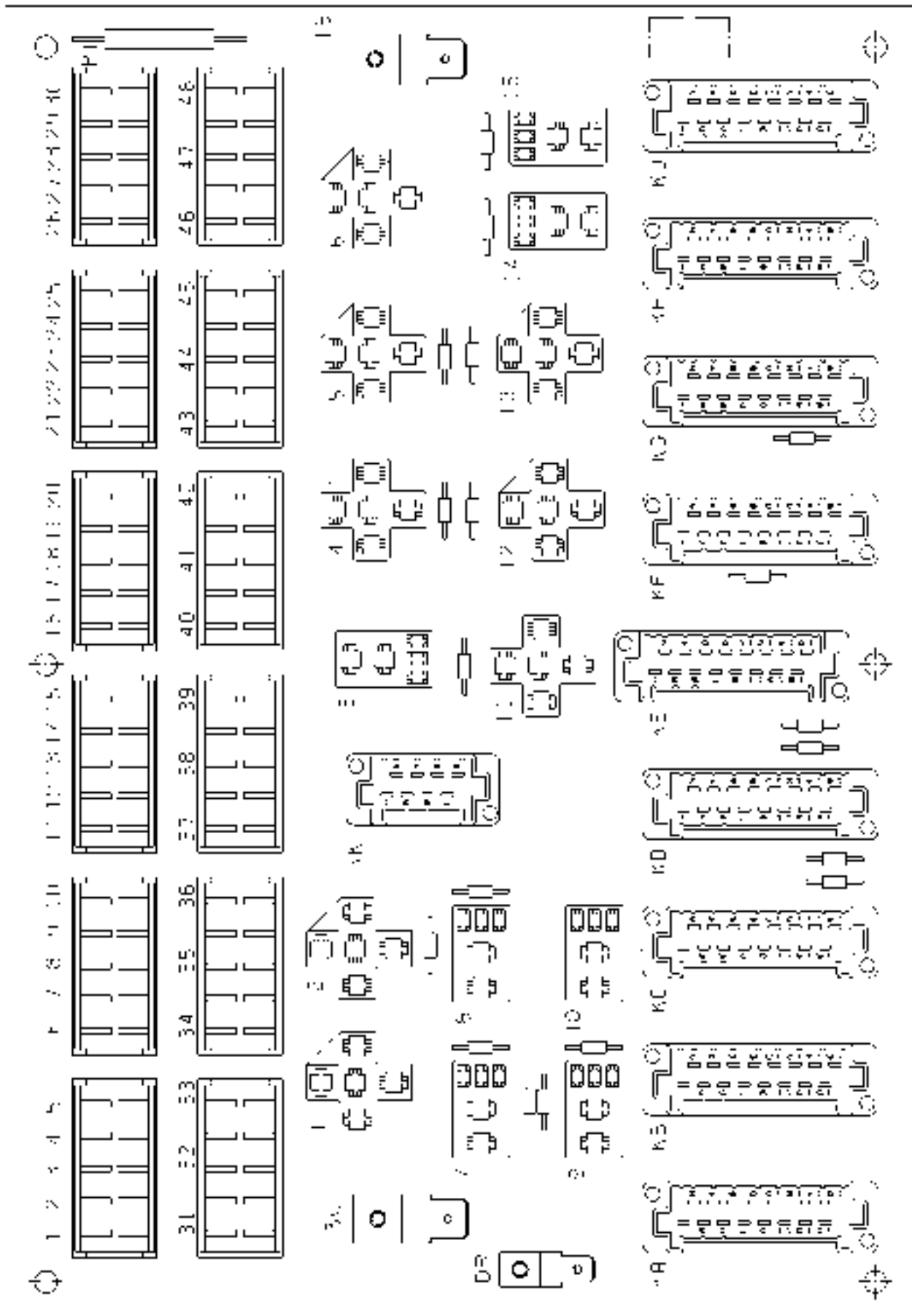

## Fuses on circuit card electrical centre

F1	Air suspension/Hydraulic bogielift (kl.DR) .....	(AA36)	F26	Differential lock, power take off ..	(LG6)
F2	Range-,area-inhibitors, compressor control .....	(AC7)	F27	Electronic climate control .....	(HA3)
F3	SRS airbag, Immobiliser .....	(AA32)	F28	Direction indicator, Instrumentation (kl.15) .....	(CN7)
F4	Central door lock .....	(KH8)	F29	Horn, solenoid valve for airhorn ..	(FA7)
F5	Interior light, timer .....	(ER16)(ES15)	F30	Cigarette lighter, centre section storagelamp .....	(EV8)
F6	Brake light trailer .....	(CK17)	F31	Voltage divider for 12V. outlets ...	(EX14)
F7	Instrumentation (kl.30) .....	(NB4)(NZ3)	F32	Foglight, rear foglight .....	(CG6)
F8	Voltage divider for radio .....	(EX7)	F33	Park. light truck lhs .....	(CE19)
F9	Brake light truck .....	(CK9)	F34	Park. light trailer lhs .....	(CE22)
F10	Spotlight .....	(CH5)(C14)	F35	Bedlamps, luggage comp. lamp, bedlock .....	(ER46)(ES46)
F11	Fullbeam flash .....	(CE64)	F36	Park. light trailer rhs .....	(CE24)
F12	Air suspension (kl.30) .....	(ME45)(MF41)(MG26)	F37	Park. light truck rhs .....	(CE26)
F13	El. heated rearview mirrors ..	(HG4)	F38	Direction indicator, hazard warning light (kl.30) .....	(CN10)
F14	Preheating, relay "radiopos." ..	(AA12)	F39	Dipped beam rhs .....	(CE53)
F15	Dipped beam lhs .....	(CE49)	F40	Fullbeam rhs .....	(CE55)
F16	Fullbeam lhs, fullbeam ind. lamp .....	(CE51)	F41	El. window winder, passenger side .....	(KA22)
F17	Radiopos. startswitch .....	(AA43)	F42	El. window winder, driver side ....	(KA4)
F18	Cooling fan control, preheat relay .....	(BL51)(BN51)	F43	Engine ECU .....	(BL23)(BN23)
F19	Vehicle ECU .....	(AC19)	F44	Revers light, revers warning alarm .....	(EA9)
F20	Engine solenoid valves .....	(BL44)(BN44)	F45	Fan, climate unit .....	(HA6)
F21	Instrumentation, el. heated mirror relay (kl.61) .....	(NA60)	F46	El heated seat, park. heater .....	(HE6)
F22	DRL (day running light/Dim-dip) .....	(CE41)	F47	Windscreen wiper .....	(GA30)
F23	El. heated airdryer .....	(HK5)	F48	Headlamp wiper, windscreen and headlamp washer .....	(GA16)
F24	Extra equipment "XA", relay bodybuilder fusebox (kl.15) ..	(XA9)			
F25	El. adjustable mirrors .....	(HH5)			

## Relays on circuit card electrical centre

301	Relay, fog lights"9"	(CG5)	315R	Relay, starting switch"4"	(AA42)
305	Relay, reversing lights"12"	(EA7)	343	Relay, rear fog lights"7"	(CG12)
306	Relay, full beams"11"	(CE55)	348A	Relay, fan,climate unit"13"	(HA6)
307	Relay, dipped beams"3"	(CE48)	360	Relay, power take off inhibitor"14"	(LD3)(LE4)
308	Relay, brake lights truck"8"	(CK8)	379	Relay, fuel injection"5"	(AC17)
308B	Relay, brake lights trailer"10"	(CK15)	3005	Alternator-controlled relay"6"	(AA52)
309L	Relay, parking lights lhs"1"	(CE19)	3101	Relay, interior lamps"15"	(ER13)(ES13)
309R	Relay, parking lights rhs"2"	(CE26)			

## Cable harness illustration index

650	Windscreen wiper motor .....	page 88
1000	Cable harness, instruments .....	page 55
1002	Cable harness, tachograph (CABLE-EC) .....	page 60
1006	Cable harness, cab, upper .....	page 61
1007	Cable harness, cab, lower .....	page 63
1017	Cable harness, engine/cab heater .....	page 65
1020	Cable harness, cowl .....	page 66
1030	Cable harness, engine .....	page 67
1037	Cable harness, bogie lift .....	page 70
1042	Cable harness, tail lights .....	page 71
1056	Cable harness, air dryer .....	page 72
1057	Cable harness, chassis .....	page 73
1061	Cable harness, parking heater, cab .....	page 74
1062	Cable harness, parking heater, frame .....	page 76
1072	Cable harness, air suspension .....	page 77
1074	Cable harness, hydraulic bogie lift with axle load limiter .....	page 80
1077	Cable harness, side marking lamp .....	page 82
1083	Cable harness, door .....	page 83
1084	Cable harness, cab, ABS .....	page 86
1086	Cable harness, solenoid valve, ABS .....	page 87
1097	Cable harness, bogie lift feeder cable .....	page 81
1402	Cable harness, windscreen washers .....	page 88
1404	Cable harness, ADR .....	page 89
1425	Cable harness, pulse sensor - tachograph (CABLE-B) .....	page 60
1433	Cable harness, bogie lift - locking, 3rd axle .....	page 91
1440	Cable harness, el. operated rearview mirror .....	page 94
1454	Cable harness, cab tilt pump .....	page 95
1465	Cable harness, additional accessories .....	page 96
1468	Cable harness, water separator .....	page 97
1469	Cable harness, fuel filter heater .....	page 98
1476	Cable harness, engine, cab .....	page 99
1488	Cable harness, central lubrication system .....	page 103
1489	Cable harness, adapter, no tachograph .....	page 55

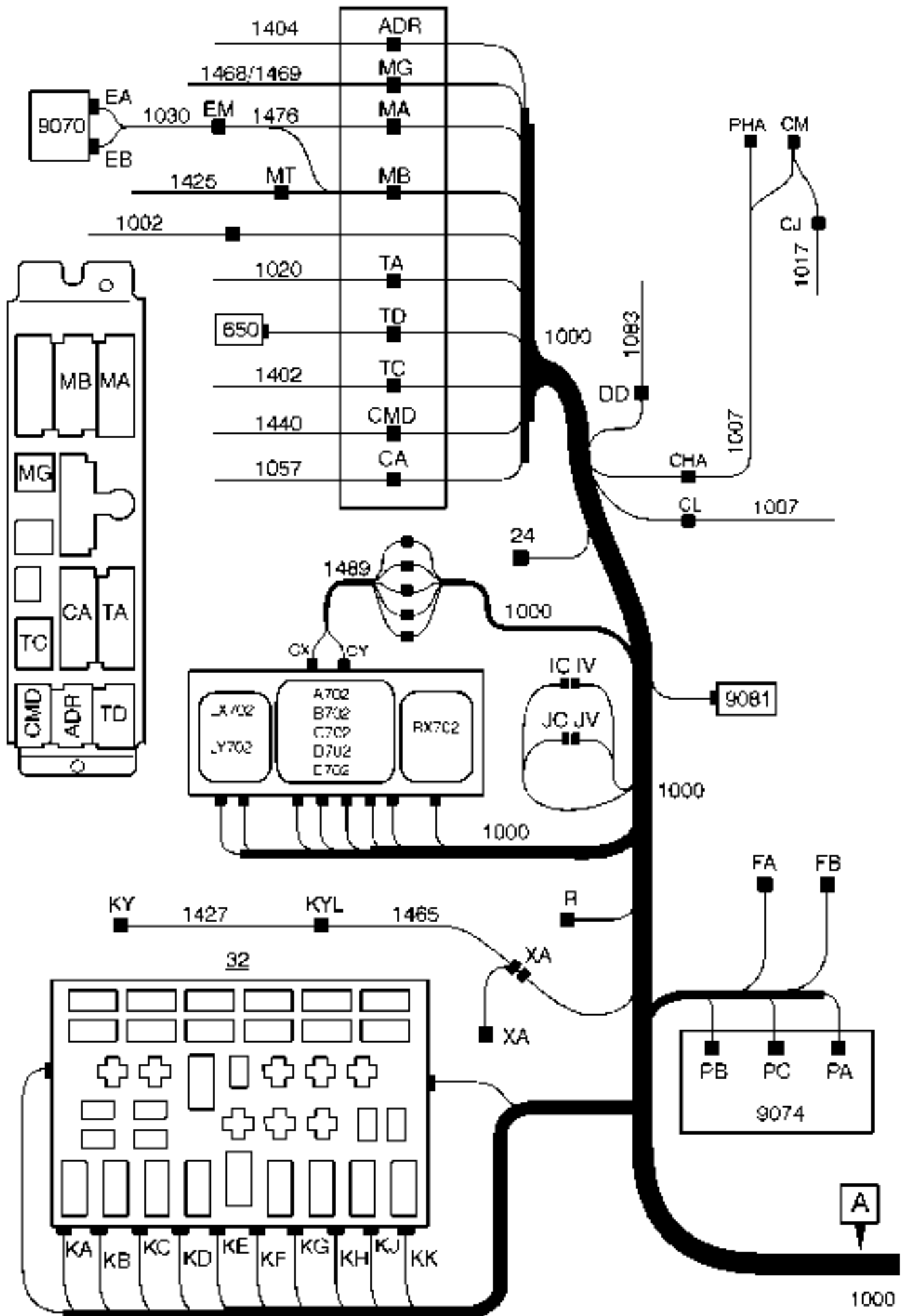

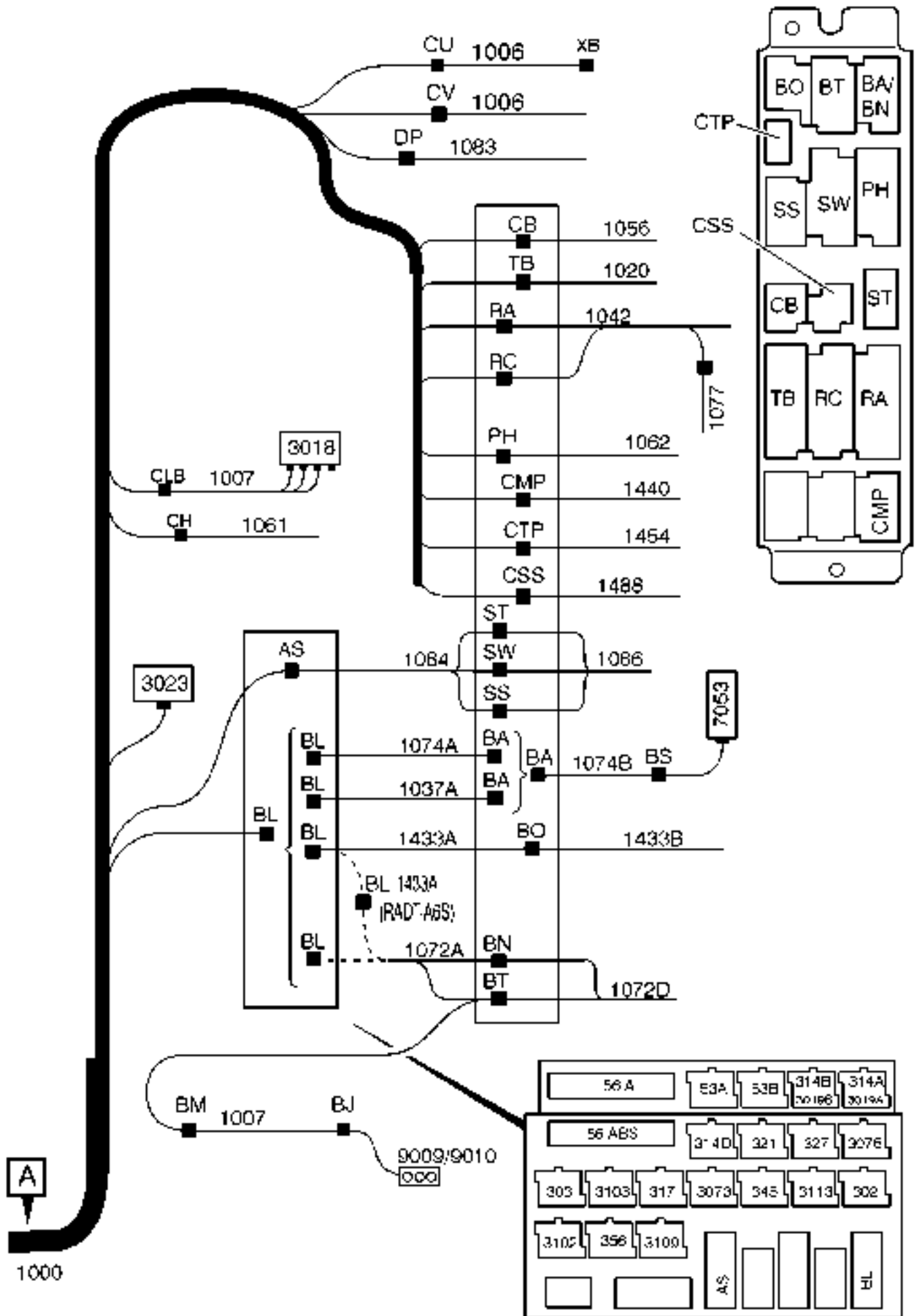

## List of connectors

A1	(NB9)	BJ2	(ME45)	BM5	(MG20)
A1	(ZD29)	BJ2	(MF34)	BM6	(ME38)
A2	(NB15)	BJ2	(MF44)	BM6	(MF38)
A2	(NZ15)	BJ2	(MG19)	BM6	(MG21)
A3	(NB11)	BJ3	(ME35)	BM7	(ME39)
A3	(NZ32)	BJ3	(MF35)	BM7	(MF39)
A4	(NB14)	BJ4	(ME36)	BM7	(MG22)
A4	(NZ13)	BJ4	(MF36)	BM8	(ME40)
A5	(NB15)	BJ5	(ME37)	BM8	(MF40)
A5	(NZ16)	BJ5	(ME46)	BM8	(MG23)
A5	(ZA11)	BJ5	(MF37)	BM8	(ZB64)
A5	(ZD36)	BJ5	(MF45)	BN1	(ME21)
A6	(NB17)	BJ5	(MG20)	BN1	(MF13)
A6	(NZ31)	BJ6	(ME38)	BN1	(MG7)
A6	(ZA1)	BJ6	(ME47)	BN2	(ME16)
ADR1	(ZD25)	BJ6	(MF38)	BN2	(MF16)
ADR2	(ZD23)	BJ6	(MF46)	BN2	(MG4)
ADR3	(ZD25)	BJ6	(MG21)	BN3	(ME17)
ADR5	(ZD33)	BJ7	(ME39)	BN3	(MF17)
ADR6	(ZD34)	BJ7	(ME48)	BN3	(MG5)
ADR7	(ZD28)	BJ7	(MF39)	BN4	(ME22)
ADR8	(ZD29)	BJ7	(MF48)	BN4	(MF22)
AS1	(CK12)	BJ7	(MG22)	BN4	(MG9)
AS10	(AC8)	BJ8	(ME40)	BN5	(ME11)
AS11	(AC24)	BJ8	(ME49)	BN5	(MF11)
AS12	(AC30)	BJ8	(MF40)	BN5	(MG4)
AS13	(CL10)	BJ8	(MF49)	BN6	(ME13)
AS14	(ZB54)	BJ8	(MG23)	BN6	(MF13)
AS2	(AC38)	BJ8	(ZB64)	BN6	(MG7)
AS3	(AC46)	BL1	(ME46)	BN7	(ME16)
AS4	(NB53)	BL1	(MF42)	BN7	(MF16)
AS4	(NZ51)	BL1	(MG27)	BN7	(MG9)
AS5	(CK19)	BL2	(AA36)	BN8	(ME18)
AS6	(OA16)	BL3	(CE41)	BN8	(MF18)
AS8	(NA44)	BL4	(NA19)	BN8	(MG6)
AS9	(NB55)	BL5	(AC37)	BO1	(LJ13)
AS9	(NZ53)	BL6	(AC47)	BO2	(LJ19)
B1	(NB20)	BL7	(NC39)	BO2	(ZB27)
B1	(NZ7)	BL8	(ME34)	BO3	(LJ28)
B1	(NZ8)	BL9	(ME35)	BO4	(LJ7)
B2	(NB21)	BL10	(AC2)	BS1	(MD16)
B2	(NZ10)	BL11	(AC6)	BS2	(MD9)
B2	(NZ9)	BL12	(EA5)	BS4	(MD12)
B3	(NB22)	BL13	(ME6)	BS4	(ZB59)
B4	(NB23)	BL13	(MF6)	BT2	(ME8)
B7	(NB29)	BL14	(LL10)	BT2	(MF8)
BA1	(MA16)	BL16	(LL12)	BT3	(ME12)
BA1	(MD16)	BL16	(MA9)	BT3	(MF12)
BA2	(MA17)	BL16	(MD12)	BT5	(ME19)
BA2	(MD27)	BL16	(ME29)	BT6	(ME21)
BA3	(MA5)	BL16	(MF29)	BT7	(ME23)
BA3	(MD5)	BL16	(MG15)	BUS1	(AC26)
BA5	(MD9)	BL16	(ZB58)	BUS2	(AC28)
BA6	(MA22)	BM1	(ME33)	BUS3	(AC36)
BA6	(MD32)	BM1	(MF33)	BUS4	(AC48)
BA7	(MA23)	BM1	(MG18)	C1	(NB33)
BA7	(MD33)	BM2	(ME34)	C2	(NB35)
BA8	(MD12)	BM2	(MF34)	C3	(NB37)
BA8	(ZB59)	BM2	(MG19)	C4	(NZ22)
BJ1	(ME33)	BM3	(ME35)	C5	(NZ24)
BJ1	(ME44)	BM3	(MF35)	C7	(NB28)
BJ1	(MF33)	BM4	(ME36)	CA1	(LE19)
BJ1	(MF43)	BM4	(MF36)	CA2	(CK4)
BJ1	(MG18)	BM5	(ME37)	CA3	(LG7)
BJ2	(ME34)	BM5	(MF37)	CA4	(LD8)



CA4	(LE9)	CM2	(ZE15)	CY4	(NZ53)
CA5	(CK8)	CM3	(HB16)	CY5	(NZ41)
CA6	(NB14)	CM3	(ZB8)	CY6	(NZ45)
CA6	(ZA2)	CM3	(ZE16)	CY7	(NZ39)
CA8	(LL10)	CM4	(HB10)	CY8	(NZ38)
CA9	(LG5)	CM4	(ZE11)	CY9	(NZ54)
CA10	(NA26)	CM5	(HB22)	CY10	(NZ36)
CA11	(NA26)	CM5	(ZE22)	CY11	(NZ31)
CA12	(AC4)	CM6	(HB19)	CY11	(ZA1)
CA13	(AC4)	CM6	(ZE19)	CY12	(NZ35)
CA16	(LD8)	CM7	(HB13)	CY13	(NZ33)
CA16	(LL10)	CM7	(ZE13)	CY14	(NZ32)
CA16	(ZB50)	CMD1	(HG4)	CY15	(NZ50)
CB1	(HK5)	CMD1	(ZA28)	CY16	(NZ51)
CB2	(HK5)	CMD2	(HG4)	CY17	(NZ51)
CB2	(ZB22)	CMD3	(HH3)	CY18	(NZ15)
CH1	(HC15)	CMD4	(HH4)	CY19	(NZ42)
CH2	(HC16)	CMD5	(HH7)	CY20	(NZ39)
CH3	(HC23)	CMP1	(HG7)	CY21	(NZ10)
CH4	(HC27)	CMP1	(ZB21)	CY22	(NZ32)
CH5	(HC29)	CMP2	(HG7)	CY24	(NZ41)
CH8	(HC32)	CMP3	(HH10)	CY25	(NZ44)
CH8	(ZB4)	CMP4	(HH11)	CY26	(NZ26)
CHA1	(HB9)	CMP5	(HH13)	CY27	(NZ20)
CHA1	(HB9)	CSS1	(TB6)	CY29	(NZ8)
CHA1	(ZE10)	CSS2	(TB6)	CY30	(NZ29)
CHA2	(HB4)	CSS2	(ZB25)	D1	(NB27)
CHA2	(HB4)	CTP1	(HP10)	D1	(NZ36)
CHA2	(ZE5)	CTP2	(HP11)	D2	(NB31)
CHA3	(HB2)	CTP2	(ZA9)	D2	(NZ29)
CHA3	(HB2)	CU1	(CE9)	D3	(NB33)
CHA3	(ZE2)	CU2	(CE37)	D4	(NB34)
CHA4	(ZE39)	CU3	(ER13)	D5	(NB36)
CHA5	(HB37)	CU3	(ES12)	D5	(NZ35)
CHA5	(HB37)	CU4	(ER46)	D6	(NB31)
CHA5	(ZE32)	CU4	(ES46)	D7	(NB50)
CHA6	(ZE31)	CU5	(ER31)	D7	(NZ48)
CHA7	(HB32)	CU5	(ES33)	D8	(NB30)
CHA7	(ZE25)	CU6	(ER24)	DD1	(KA5)
CHA8	(HB33)	CU6	(ES21)	DD2	(KA17)
CHA8	(ZE27)	CU7	(KB3)	DD3	(KH12)
CHA9	(HB33)	CU8	(ER12)	DD4	(KH14)
CHA9	(HB33)	CU8	(ES12)	DD5	(KA11)
CHA9	(ZB7)	CU9	(XA43)	DD6	(KA12)
CHA9	(ZE39)	CU9	(EN4)	DD7	(KH5)
CJ1	(HB11)	CU10	(XA45)	DD8	(KH8)
CJ2	(HB14)	CU10	(EN6)	DD9	(KH9)
CJ3	(HB16)	CU11	(CE61)	DD10	(JA12)
CJ3	(ZB8)	CU12	(ER24)	DD11	(JA13)
CJ6	(HB19)	CU12	(ES21)	DD12	(ER4)
CJ7	(HB13)	CU13	(JA18)	DD12	(ES4)
CL1	(ER53)	CU14	(JA19)	DD13	(HH3)
CL1	(ES60)	CU15	(JA21)	DD14	(HH4)
CL2	(HE6)	CU16	(JA22)	DD15	(HH7)
CL3	(NA42)	CV1	(NB33)	DD16	(HH10)
CL4	(ED6)	CV2	(NB35)	DD17	(HH11)
CL5	(HE18)	CV3	(NB37)	DD18	(HH13)
CL6	(HE23)	CV4	(NB5)	DD19	(HH5)
CL8	(NB47)	CX1	(NZ22)	DD20	(KA27)
CL8	(NZ47)	CX2	(NZ24)	DD21	(KA29)
CL23	(NB47)	CX3	(NZ18)	DD22	(ER9)
CL23	(ZA33)	CX4	(NZ13)	DD22	(ES8)
CL24	(NA42)	CX5	(NZ16)	DD24	(ER5)
CL24	(ZA35)	CX5	(ZA11)	DD24	(ES5)
CM1	(HB11)	CY1	(NZ47)	DD24	(KA11)
CM1	(ZE12)	CY2	(NZ48)	DD24	(KA28)
CM2	(HB14)	CY3	(NZ45)	DD24	(ZA49)

DP1	(KA22)	EA18	(BL10)	EM2	(BL34)
DP2	(KA36)	EA18	(BN54)	EM2	(BN34)
DP5	(KA37)	EA22	(BL30)	EM3	(BL36)
DP6	(KA39)	EA23	(BL32)	EM3	(BN36)
DP7	(KH13)	EA24	(BL39)	EM4	(BL30)
DP8	(KH17)	EA25	(BL21)	EM4	(BN30)
DP9	(KH18)	EA25	(BN26)	EM5	(BL31)
DP10	(JA15)	EA27	(BL4)	EM5	(BN31)
DP11	(JA16)	EA27	(BN4)	EM6	(BL51)
DP12	(ER19)	EA29	(BN45)	EM6	(BN51)
DP12	(ES19)	EA30	(BL6)	EM7	(BL44)
DP22	(ER16)	EA30	(BN6)	EM7	(BN44)
DP22	(ES17)	EA31	(BL7)	EM8	(BL33)
DP24	(ER19)	EA31	(BN7)	EM8	(BN33)
DP24	(ES20)	EA33	(BL44)	EM9	(BL23)
DP24	(KA38)	EA34	(BL35)	EM9	(BN23)
DP24	(ZB42)	EA35	(BL37)	EM10	(BL56)
E1	(NB23)	EA36	(BL38)	EM10	(BN56)
E2	(NB26)	EB1	(BL34)	EM10	(ZA16)
E3	(NB39)	EB1	(BN34)	EM11	(BL49)
E3	(NZ38)	EB2	(BL36)	EM11	(BN49)
E4	(NB47)	EB2	(BN36)	FA1	(AC53)
E4	(NZ47)	EB3	(BL9)	FA2	(AC55)
E5	(NB56)	EB3	(BN9)	FA3	(AC56)
E5	(NZ54)	EB4	(BL27)	FA4	(AC59)
E6	(NB25)	EB4	(BN27)	FA5	(AC58)
E6	(NZ18)	EB5	(BL52)	FA6	(AC61)
E7	(NB45)	EB5	(BN52)	FA7	(AC62)
E7	(NZ45)	EB7	(BL17)	FA8	(AC63)
E8	(NB40)	EB7	(BN17)	FA9	(AC64)
E8	(NZ39)	EB8	(BL19)	FA10	(AC10)
E9	(NB42)	EB8	(BN18)	FA11	(ME6)
E9	(NZ41)	EB9	(BL53)	FA11	(MF6)
E10	(NB48)	EB9	(BN53)	FA13	(CN2)
E10	(NZ45)	EB10	(BL55)	FB1	(NB30)
E11	(NB53)	EB10	(BN55)	FB2	(EA7)
E12	(NB32)	EB11	(BL23)	FB3	(NB51)
E13	(NB43)	EB11	(BN23)	FB3	(NZ50)
E13	(NZ44)	EB12	(BL25)	FB4	(LD14)
E14	(NB52)	EB12	(BN24)	FB4	(LE26)
E15	(NB53)	EB13	(BL11)	FB5	(NB58)
E15	(NZ51)	EB13	(BN11)	FB5	(NZ57)
E16	(NB55)	EB15	(BL5)	FB6	(CK6)
E16	(NZ53)	EB15	(BN5)	FB7	(NB42)
EA1	(BL23)	EB17	(BL21)	FB7	(NZ43)
EA1	(BN29)	EB17	(BN21)	FB8	(FA9)
EA2	(BL12)	EB21	(BL38)	FB9	(ED5)
EA2	(BN17)	EB21	(BN38)	FB10	(AC44)
EA3	(BL13)	EB24	(BL33)	FB11	(AC44)
EA3	(BN18)	EB24	(BN33)	FB12	(AC36)
EA4	(BL13)	EB25	(BL30)	FB13	(AC36)
EA4	(BN18)	EB25	(BN30)	FB14	(AC36)
EA5	(BL18)	EB26	(BL32)	FB15	(EA19)
EA5	(BN24)	EB26	(BN32)	FB16	(AA18)
EA7	(BL9)	EB31	(BL51)	FB17	(AA18)
EA7	(BN52)	EB31	(BN51)	FB18	(EA24)
EA8	(BL50)	EB35	(BL42)	IC1	(TB4)
EA9	(BN52)	EB35	(BN42)	IC2	(TB6)
EA10	(BN52)	EB36	(BL45)	IC2	(ZB25)
EA11	(BL28)	EB36	(BN45)	IC3	(LD14)
EA12	(BL33)	EBS1	(CE34)	IC3	(LE26)
EA13	(BL3)	EBS2	(NB26)	IC4	(AC43)
EA13	(BN3)	EBS3	(NB41)	IC5	(AA16)
EA14	(BL24)	EBS4	(LG7)	IC6	(NB56)
EA14	(BN29)	EBS5	(LG7)	IC6	(NZ54)
EA16	(BN49)	EM1	(BL27)	IC7	(EA13)
EA17	(BN47)	EM1	(BN28)	IC9	(ED6)

IV1	(TB4)	JV11	(ZA56)	KD5	(CE26)
IV2	(TB6)	JV12	(HE26)	KD6	(CN10)
IV2	(ZB25)	JV12	(ZA54)	KD7	(CN17)
IV3	(LD14)	JV13	(KH19)	KD8	(CN17)
IV3	(LE26)	JV13	(ZA53)	KD9	(CH5)
IV4	(AC43)	JV14	(LD10)	KD9	(C15)
IV5	(AA16)	JV14	(LE11)	KD10	(CE64)
IV6	(NB56)	JV14	(ZA61)	KD11	(NB3)
IV6	(NZ54)	JV15	(PA14)	KD12	(NB4)
IV7	(EA13)	JV15	(ZA58)	KD12	(NZ3)
IV9	(ED6)	JV16	(HA10)	KD13	(CE35)
JC1	(HM9)	JV17	(AC49)	KD15	(AC7)
JC1	(HO6)	JV22	(NB42)	KD16	(AC2)
JC1	(ZA63)	JV22	(NZ43)	KE1	(PA7)
JC2	(AC30)	JV23	(AC62)	KE2	(CE53)
JC3	(HP13)	JV24	(AC63)	KE3	(ME45)
JC3	(ZB56)	KA1	(CE9)	KE3	(MF41)
JC4	(LD16)	KA2	(CE12)	KE3	(MG26)
JC4	(LE13)	KA3	(CE14)	KE4	(CE47)
JC5	(LE20)	KA4	(CE17)	KE5	(ME46)
JC5	(NB8)	KA5	(CE9)	KE5	(MF42)
JC6	(LD18)	KA6	(EV10)	KE5	(MG27)
JC6	(LE28)	KA7	(CE14)	KE6	(CE49)
JC7	(KE10)	KA8	(CE17)	KE7	(HG4)
JC8	(KE10)	KA9	(CE19)	KE8	(CE46)
JC9	(ER20)	KA10	(XA54)	KE9	(CE56)
JC9	(ES17)	KA11	(AA39)	KE10	(CE43)
JC10	(CH14)	KA12	(CG13)	KE11	(CE44)
JC10	(CI14)	KA13	(AC15)	KE12	(CE64)
JC10	(ZA59)	KA14	(CE37)	KE13	(CE50)
JC11	(HA6)	KB1	(CE21)	KE14	(AA34)
JC11	(ZA56)	KB2	(CE22)	KE15	(AA32)
JC12	(HE26)	KB3	(CG6)	KE16	(CE51)
JC12	(ZA54)	KB4	(CG8)	KF1	(KA22)
JC13	(KH19)	KB5	(AA36)	KF2	(KA5)
JC13	(ZA53)	KB6	(AA37)	KF3	(KA23)
JC14	(LD10)	KB7	(CE37)	KF4	(CE51)
JC14	(LE11)	KB8	(CE37)	KF5	(CE55)
JC14	(ZA61)	KB9	(CG12)	KF6	(EA9)
JC15	(PA14)	KB10	(CG5)	KF7	(CE57)
JC15	(ZA58)	KB12	(CE29)	KF8	(EA13)
JC16	(HA10)	KB12	(ZB15)	KF9	(CE64)
JC17	(AC49)	KB14	(EX14)	KF10	(AA43)
JC22	(NB42)	KB15	(CG15)	KF11	(AA45)
JC22	(NZ43)	KB16	(EX18)	KF12	(AA46)
JC23	(AC62)	KC1	(CE24)	KF13	(AA48)
JC24	(AC63)	KC2	(CE25)	KF14	(KH7)
JV1	(HM9)	KC3	(CE38)	KF15	(KH8)
JV1	(HO6)	KC4	(AC12)	KF16	(BL51)
JV1	(ZA63)	KC5	(CK17)	KF16	(BN51)
JV2	(AC30)	KC6	(CK4)	KG1	(BL23)
JV3	(HP13)	KC7	(CK19)	KG1	(BN23)
JV3	(ZB56)	KC8	(CK6)	KG2	(XA13)
JV4	(LD16)	KC9	(CK9)	KG3	(BL25)
JV4	(LE13)	KC10	(CK8)	KG3	(BN24)
JV5	(LE20)	KC11	(CK12)	KG4	(XA9)
JV5	(NB8)	KC12	(CE27)	KG5	(AA11)
JV6	(LD18)	KC13	(EX7)	KG6	(HA6)
JV6	(LE28)	KC14	(EX10)	KG7	(AA12)
JV7	(KE10)	KC15	(ER46)	KG8	(HA4)
JV8	(KE10)	KC15	(ES46)	KG9	(AA34)
JV9	(ER20)	KC16	(ER53)	KG10	(AC17)
JV9	(ES17)	KC16	(ES60)	KG11	(EA4)
JV10	(CH14)	KD1	(CE34)	KG12	(BL44)
JV10	(CI14)	KD2	(CE32)	KG12	(BN44)
JV10	(ZA59)	KD3	(CE34)	KG13	(EA8)
JV11	(HA6)	KD4	(CE32)	KG14	(AC19)

KG15	(AA37)	LX12	(NA4)	MB15	(EA4)
KG16	(AA39)	LX12	(ZA2)	MB16	(EA4)
KH1	(CE41)	LX13	(NA24)	MB16	(NZ48)
KH2	(HE6)	LX14	(NA15)	MB16	(ZA51)
KH3	(HH5)	LX15	(NA49)	MG1	(HM14)
KH4	(HE12)	LX16	(NA35)	MG2	(HM14)
KH5	(HH7)	LX17	(NA8)	MG2	(ZA19)
KH6	(LD5)	LX18	(NA9)	MG3	(HO6)
KH6	(LE6)	LX20	(NA4)	MG4	(H06)
KH7	(NA60)	LX21	(NA32)	MG4	(ZA63)
KH8	(LD7)	LX22	(NA53)	MS1	(NB18)
KH8	(LE8)	LY1	(NA45)	MS1	(NZ7)
KH9	(NA63)	LY3	(NA48)	MS2	(NB19)
KH10	(LD7)	LY4	(NA51)	MS2	(NZ9)
KH10	(LE8)	LY5	(NA56)	MS3	(NB24)
KH11	(LG6)	LY6	(NA54)	MS3	(NZ15)
KH12	(AA50)	LY7	(NA42)	MS4	(NB25)
KH13	(HA5)	LY8	(NA19)	MS4	(NZ13)
KH14	(HA7)	LY9	(NA30)	MT1	(NB20)
KH15	(CN3)	LY10	(NA53)	MT1	(NZ8)
KH16	(CN7)	LY11	(NA51)	MT2	(NB21)
KJ1	(AA42)	LY12	(NA29)	MT2	(NZ10)
KJ1	(ZB13)	LY20	(NA44)	MT3	(NB22)
KJ2	(GA23)	LY21	(NA25)	MT3	(NZ11)
KJ3	(GA30)	LY22	(NA7)	MT4	(NB23)
KJ4	(EV6)	LY23	(NA47)	MT4	(NZ12)
KJ5	(XA52)	LY25	(NA27)	NF1	(NB15)
KJ6	(EV8)	LY26	(NA26)	NF1	(ZA5)
KJ7	(FA4)	LY28	(NA31)	NF2	(NB15)
KJ8	(GA25)	MA1	(HA13)	NF2	(ZA5)
KJ9	(FA7)	MA2	(AA16)	PA1	(AC37)
KJ10	(GA16)	MA3	(AC23)	PA2	(AC38)
KJ11	(HK5)	MA4	(AC31)	PA3	(AC40)
KJ12	(ER12)	MA5	(AC33)	PA4	(AC59)
KJ12	(ES12)	MA6	(AC52)	PA5	(AC32)
KJ13	(ER13)	MA7	(AA21)	PA6	(AC5)
KJ13	(ES12)	MA8	(BL51)	PA7	(AC14)
KJ14	(ER18)	MA8	(BN51)	PA8	(AC34)
KJ14	(ES18)	MA9	(BL49)	PA9	(AC60)
KJ15	(ER21)	MA9	(BN49)	PA10	(AC62)
KJ15	(ES22)	MA11	(BL23)	PA11	(AC61)
KJ16	(ER14)	MA11	(BN23)	PA12	(AC18)
KJ16	(ES13)	MA12	(BL56)	PA13	(AC19)
KK1	(CE42)	MA12	(BN56)	PA14	(AC15)
KK2	(CE41)	MA12	(ZA16)	PA15	(AC55)
KK3	(CE38)	MA13	(AA50)	PA17	(AC58)
KK4	(CE37)	MA14	(BL44)	PA18	(AC29)
KK5	(CE42)	MA14	(BN44)	PA20	(AC48)
KK6	(CE41)	MA15	(AC4)	PA21	(AC46)
KK7	(CE38)	MB1	(NA29)	PA23	(AC25)
KK8	(CE37)	MB2	(AC9)	PA24	(AC63)
KY1	(TA15)	MB4	(AC12)	PA26	(AC53)
KY2	(TA15)	MB5	(NA31)	PA27	(AC61)
KYL1	(TA15)	MB6	(NA29)	PA28	(AC8)
KYL2	(TA15)	MB7	(NA30)	PA29	(AC6)
LX1	(NA8)	MB8	(AC7)	PA30	(AC39)
LX2	(NA18)	MB9	(AC7)	PB2	(AC11)
LX3	(NA20)	MB10	(NB20)	PB4	(AC4)
LX4	(NA34)	MB10	(NZ8)	PB5	(AC43)
LX5	(NA37)	MB11	(NB21)	PB6	(AC9)
LX6	(NA36)	MB11	(NZ10)	PB8	(AC23)
LX7	(NA33)	MB12	(NB22)	PB9	(AC20)
LX8	(NA38)	MB12	(NZ15)	PB10	(AC22)
LX9	(NA11)	MB13	(NB23)	PB11	(AC16)
LX9	(ZA9)	MB13	(NZ13)	PB14	(AC56)
LX10	(NA30)	MB14	(NB50)	PB15	(AC17)
LX11	(NA10)	MB14	(NZ48)	PB16	(AC15)

PB17	(AC4)	RC7	(CG21)	SW3	(OB32)
PB18	(AC6)	RC8	(CE42)	SW3	(ZB49)
PB19	(AC30)	RC8	(ZB8)	SW4	(OA37)
PB20	(AC11)	RC10	(EA24)	SW4	(OB37)
PB21	(AC9)	RC11	(XA43)	SW5	(OA38)
PB22	(AC24)	RC12	(XA53)	SW5	(OB38)
PB23	(AC22)	RC13	(XA47)	SW6	(OA37)
PB24	(AC64)	RC14	(CG19)	SW6	(OB40)
PB26	(AC19)	RC15	(CN12)	SW6	(ZB51)
PB27	(AC12)	RC16	(CN17)	SW7	(OA45)
PB28	(AC64)	RX1	(NC27)	SW7	(OB45)
PC1	(AC46)	RX2	(NC13)	SW8	(OA46)
PC2	(AC38)	RX2	(ZA10)	SW8	(OB46)
PC4	(AC26)	RX3	(NC6)	SW9	(OA45)
PC5	(AC28)	RX4	(NC3)	SW9	(OB48)
PH1	(HC7)	RX5	(NC14)	SW9	(ZB52)
PH2	(HC9)	RX6	(NC13)	SW10	(OA53)
PH3	(HC11)	RX7	(NC15)	SW10	(OB53)
PH4	(HC13)	RX8	(NC41)	SW11	(OA54)
PH5	(HC15)	RX9	(NC43)	SW11	(OB54)
PH6	(HC17)	RX10	(NC45)	SW12	(OA53)
PH7	(HC20)	RX11	(NC36)	SW12	(OB56)
PH8	(HC21)	RX12	(NC51)	SW12	(ZB54)
PH16	(HC25)	RX13	(NC35)	SW14	(OA14)
PH16	(ZB6)	RX14	(NC33)	SW14	(OB12)
PHA1	(HB9)	RX15	(NC27)	SW15	(OA3)
PHA1	(ZE10)	RX15	(ZA7)	SW15	(OB3)
PHA2	(HB4)	RX16	(NC14)	SW16	(OA10)
PHA2	(ZE5)	RX17	(NC10)	SW16	(OB8)
PHA3	(HB2)	RX18	(NC11)	SW16	(ZB41)
PHA3	(ZE2)	RX19	(NC39)	SW16	(ZB55)
PHA5	(HB23)	RX20	(NC49)	TA1	(CE50)
PHA5	(ZE32)	RX21	(NC16)	TA1	(ZA21)
PHA6	(HB17)	RX22	(NC37)	TA2	(CE51)
PHA6	(ZE18)	RX23	(NC42)	TA3	(CE49)
PHA7	(HB20)	RX24	(NC44)	TA4	(GA16)
PHA7	(ZE21)	RX25	(NC50)	TA5	(GA15)
PHA8	(HB33)	RX26	(NC47)	TA6	(CH5)
PHA8	(ZB7)	RX27	(NC46)	TA6	(CI5)
PHA8	(ZE39)	RX28	(NC34)	TA7	(CN9)
R16	(ZB36)	RX30	(NC31)	TA8	(CE14)
RA1	(ZB12)	SS1	(OA26)	TA9	(CG6)
RA2	(CE19)	SS1	(OB26)	TA10	(FA7)
RA3	(CN14)	SS2	(OA27)	TA11	(FA7)
RA4	(CK9)	SS2	(OB27)	TA13	(NB36)
RA5	(CN15)	SS3	(OA34)	TA13	(NZ35)
RA6	(CE26)	SS3	(OB34)	TA14	(PA4)
RA7	(EA9)	SS4	(OA35)	TA15	(PA5)
RA8	(CG13)	SS4	(OB35)	TA16	(PA7)
RA10	(EA18)	SS5	(OA42)	TACHO1:1	(ZD10)
RA11	(CK14)	SS5	(OB42)	TACHO1:2	(ZD10)
RA12	(NA18)	SS6	(OA43)	TACHO2:1	(ZD13)
RA13	(NA21)	SS6	(OB43)	TACHO2:2	(ZD13)
RA14	(LG23)	SS7	(OA50)	TB1	(CE54)
RA15	(HB4)	SS7	(OB50)	TB1	(ZB4)
RA15	(HC5)	SS8	(OA51)	TB2	(CE55)
RA15	(ZE4)	SS8	(OB51)	TB3	(CE53)
RA16	(HB2)	ST1	(OA22)	TB4	(GA21)
RA16	(HC2)	ST1	(OB21)	TB5	(GA19)
RA16	(ZE2)	ST2	(OA18)	TB6	(CH6)
RC1	(CE47)	ST2	(OB16)	TB6	(CI6)
RC1	(ZB7)	ST2	(ZB34)	TB7	(CN10)
RC2	(CE22)	SW1	(OA29)	TB8	(CE32)
RC3	(CN5)	SW1	(OB29)	TB9	(CG8)
RC4	(CK17)	SW2	(OA31)	TB10	(FA4)
RC5	(CN7)	SW2	(OB31)	TB11	(FA4)
RC6	(CE24)	SW3	(OA29)	TB14	(PA10)

TB15	(PA11)	TD7	(GA29)	XB1	(EN4)
TB16	(PA13)	TD8	(GA30)	XB1	(XA43)
TC1	(GA5)	XA1	(TA4)	XB2	(EN10)
TC2	(GA3)	XA1	(TA7)	XB2	(EN6)
TC3	(GA9)	XA1	(XA3)	XB2	(XA45)
TC4	(GA5)	XA2	(XA5)	XB3	(CE61)
TC4	(ZA43)	XA3	(TA3)	XB4	(EN15)
TD3	(GA32)	XA3	(TA6)	XB4	(EN16)
TD3	(ZA24)	XA3	(XA7)	XB4	(XA45)
TD5	(GA31)	XA3	(ZB11)	XB4	(ZA41)
TD6	(GA33)				

# List of components

24	Connector, socket/diagnostics (AC39)	77	Plug socket, 7-unit (CK17)
24	Connector, socket/diagnostics (KE8)	77	Plug socket, 7-unit (CN5)
24: 8	Connector, socket/diagnostics (ZA4)	77	Plug socket, 7-unit (CN7)
30	Battery (ZA46)	77	Plug socket, 7-unit (ZB7)
30 A	Battery (AA8)	78	Extra plug socket, 7-unit (CE43)
30 A	Battery (ZD4)	78	Extra plug socket, 7-unit (CG19)
30 B	Battery (AA8)	78	Extra plug socket, 7-unit (EA24)
30 B	Battery (ZD4)	78	Extra plug socket, 7-unit (XA43)
32	Circuit card, electrical centre (AA10)	78	Extra plug socket, 7-unit (XA47)
32	Circuit card, electrical centre (AA31)	78	Extra plug socket, 7-unit (XA53)
32	Circuit card, electrical centre (AA32)	78	Extra plug socket, 7-unit (ZB8)
32	Circuit card, electrical centre (ZD21)	79	Plug socket, ABS/EBS (OA10)
34	Connector (AA4)	79	Plug socket, ABS/EBS (OA14)
34	Connector (EN6)	79	Plug socket, ABS/EBS (OA18)
34	Connector (TA8)	79	Plug socket, ABS/EBS (OA22)
34	Connector (ZD21)	79	Plug socket, ABS/EBS (OA3)
36	Connector, tail lamp junction box (CE22)	79	Plug socket, ABS/EBS (OB3)
36	Connector, tail lamp junction box (CE24)	79	Plug socket, ABS/EBS (OB8)
36	Connector, tail lamp junction box (CE45)	79	Plug socket, ABS/EBS (OB12)
36	Connector, tail lamp junction box (CG19)	79	Plug socket, ABS/EBS (OB16)
36	Connector, tail lamp junction box (CG21)	79	Plug socket, ABS/EBS (OB21)
36	Connector, tail lamp junction box (CK14)	79:3	Plug socket, ABS/EBS (ZB41)
36	Connector, tail lamp junction box (CK17)	79:3	Plug socket, ABS/EBS (ZB55)
36	Connector, tail lamp junction box (CN5)	79:4	Plug socket, ABS/EBS (ZB34)
36	Connector, tail lamp junction box (CN7)	100	Switch, headlights (CE36)
36	Connector, tail lamp junction box (CN12)	100	Switch, headlights (ZB15)
36	Connector, tail lamp junction box (CN17)	101	Switch, full beams and dipped beams (CE61)
36	Connector, tail lamp junction box (EA24)	101	Switch, full beams and dipped beams (ZA56)
36	Connector, tail lamp junction box (XA43)	102	Switch, fog lights (CG21)
36	Connector, tail lamp junction box (XA47)	102	Switch, fog lights (ZA41)
36	Connector, tail lamp junction box (XA53)	103	Switch, spot lights (CH10)
42	Joint sleeve (ZA21)	103	Switch, spot lights (CI10)
42	Joint sleeve (ZA35)	103	Switch, spot lights (ZA59)
42	Joint sleeve (ZA45)	104	Switch, loading lights (ED9)
42	Joint sleeve (ZA49)	104	Switch, loading lights (ZA41)
42	Joint sleeve (ZB4)	109	Switch, hazard warning lights (CN17)
42	Joint sleeve (ZB7)	109	Switch, hazard warning lights (ZA41)
42	Joint sleeve (ZB27)	111 DD	Switch, window winder (KA10)
42	Joint sleeve (ZB38)	111 DP	Switch, window winder (KA27)
42	Joint sleeve (ZB58)	111 P	Switch, window winder (KA37)
42 A	Joint sleeve (ZB12)	111 DD	Switch, window winder (ZA47)
42 A	Joint sleeve (ZB50)	111 DP	Switch, window winder (ZA47)
42 C	Joint sleeve (ZA19)	111 P	Switch, window winder (ZB43)
42 I 1:1	Joint sleeve (ZA4)	112	Switch, air conditioning (HA19)
42 I 1:3A	Joint sleeve (ZA41)	112	Switch, air conditioning (ZA56)
42 I 1:3B	Joint sleeve (ZA56)	112 ATC	Switch, air conditioning (HA5)
42 I 2:4A	Joint sleeve (ZB45)	112 ATC	Switch, air conditioning (ZA56)
42 I 2:4B	Joint sleeve (ZB54)	116 A	Switch, interior light (ES27)
42 I HEAT	Joint sleeve (ZB2)	116 A	Switch, interior light (ZA27)
42 MB	Joint sleeve (ZA51)	116 B	Switch, interior light (ER37)
42 S	Joint sleeve (ZA33)	116 B	Switch, interior light (ES35)
51	Fuse holder 1-unit (ZD18)	116 B	Switch, interior light (ZA18)
53 A	Fuse holder 3-unit (HM10)	116 B	Switch, interior light (ZA19)
53 A	Fuse holder 3-unit (HP4)	118	Switch, fan (HA13)
56 A	Fuse holder 6-unit (XA18)	119	Switch, windscreen wiper (GA25)
56 A	Fuse holder 6-unit (TA9)	123	Switch, heated rearview mirror (HG12)
56 P	Fuse holder, 6-unit (XA31)	123	Switch, heated rearview mirror (ZA41)
56 X	Fuse holder, 6-unit (XA44)	125	Switch, exhaust brake (AC46)
56 X	Fuse holder, 6-unit (EN4)	125	Switch, exhaust brake (ZB54)
56 ABS	Fuse holder, 6-unit (OA14)	126	Switch, diff. lock wheels, rear (LG18)
56 ABS	Fuse holder, 6-unit (OB12)	127	Switch, diff. lock inter axles (LG6)
77	Plug socket, 7-unit (CE22)	127	Switch, diff. lock inter axles (ZB54)
77	Plug socket, 7-unit (CE24)	132	Switch, roof sign light (EJ4)
77	Plug socket, 7-unit (CE45)	132	Switch, roof sign light (EK4)
77	Plug socket, 7-unit (CG21)	132	Switch, roof sign light (ZA33)

133	Switch, bogie lift (LJ11)	214	Closing contact, indicator light, low split (NZ48)
133	Switch, bogie lift (MA5)	214	Closing contact, indicator light, low split (ZA51)
133	Switch, bogie lift (MD4)	216 A	Closing contact, brake lights (CK8)
133	Switch, bogie lift (ME40)	216 A	Closing contact, brake lights (ZB48)
133	Switch, bogie lift (ZB30)	216 B	Closing contact, brake lights (CK4)
133	Switch, bogie lift (ZB61)	216 B	Closing contact, brake lights (ZB48)
144	Switch, battery master switch (AA8)	216 C	Closing contact, brake lights (CK4)
144	Switch, battery master switch (ZA2)	217	Closing contact, reversing lights (EA4)
144/144AD	Switch, battery master switch (ZA46)	217	Closing contact, reversing lights (ZA51)
144 ADR	Switch, battery master switch (ZD10)	218	Break contact, exh-pressure governor (AC16)
147	Switch, direction indicators (CN7)	218	Break contact, exh-pressure governor (ZB45)
149	Switch, horn (FA6)	223	Slip contact, horn (FA7)
149	Switch, horn (ZA58)	223	Slip contact, horn (ZA59)
150	Switch, starting switch (AA15)	228 L	Closing contact, cab lock (NA40)
157	Switch, air horn (FA9)	228 L	Closing contact, cab lock (ZA35)
157	Switch, air horn (ZA58)	228 R	Closing contact, cab lock (NA42)
172	Switch, extra (EN10)	228 R	Closing contact, cab lock (ZA35)
172	Switch, extra (TA5)	258	Break contact, thermal, bogie lift (ZA50)
179	Switch, 3rd axle lock (LJ28)	2003	Thermostat, parking heater (HB11)
179	Switch, 3rd axle lock (LL10)	2003	Thermostat, parking heater (HC27)
179	Switch, 3rd axle lock (ZB28)	2003	Thermostat, parking heater (ZB4)
1101	Switch, parking heater (ZE25)	2003	Thermostat, parking heater (ZB8)
1105	Switch, levelling control, headlights (PA10)	2003	Thermostat, parking heater (ZE12)
1105	Switch, levelling control, headlights (ZA58)	2004 L	Break contact, lighting luggage compartment (ER53)
1107	Switch, door lock (KH13)		
1107	Switch, door lock (ZA45)	2004 L	Break contact, lighting luggage compartment (ES60)
1122	Switch, retarder (AC52)		
1132 D	Switch, el. operated rearview mirror (HH4)	2007	Break contact, clutch pedal (AC34)
1132 D	Switch, el. operated rearview mirror (ZA49)	2008	Break contact, brake pedal (AC32)
1132 P	Switch, el. operated rearview mirror (HH10)	2018	Contact, oil pressure, power steering (NB36)
1132 P	Switch, el. operated rearview mirror (ZA49)	2018	Contact, oil pressure, power steering (NZ35)
1135	Switch, cruise control (AC40)	2018	Contact, oil pressure, power steering (ZA22)
1146	Switch, snooze function/radio (ER37)	2019	Contact, lock, seat belt (NB47)
1146	Switch, snooze function/radio (ES39)	2019	Contact, lock, seat belt (NZ47)
1146	Switch, snooze function/radio (ZA22)	2019	Contact, lock, seat belt (ZA29)
1147 A	Switch, cab tilt pump (HP11)	2020 L	Contact, bunk lock (ES54)
1147 A	Switch, cab tilt pump (ZB56)	2020 L	Contact, bunk lock (ZA41)
1147 B	Switch, cab tilt pump (HP10)	2020 R	Contact, bunk lock (ES53)
1148	Switch, storage compartment lighting (EV4)	2020 R	Contact, bunk lock (ZA43)
1149 1	Switch, PTO (ZA61)	2074	Contact, low range (AC9)
1149 1	Switch, PTO (LD7)	301	Relay, fog lights (CG5)
1149 1	Switch, PTO (LE8)	302	Relay, spot lights (CH5)
1149 2	Switch, PTO (LE18)	302	Relay, spot lights (CI5)
1149 2	Switch, PTO (ZA61)	303	Relay, loading lights (ED6)
1150	Switch, fuel filter heater (HM7)	303	Relay, loading lights (ZB54)
1150	Switch, fuel filter heater (ZA63)	305	Relay, reversing lights (EA8)
1152	Switch, multi-function display (NA33)	306	Relay, full beams (CE55)
200	Break contact, warning light, parking brake (NB56)	307	Relay, dipped beams (CE48)
200	Break contact, warning light, parking brake (NZ54)	308	Relay, brake lights (CK8)
200	Break contact, warning light, parking brake (ZB45)	308 B	Relay, brake lights (CK15)
205 D	Break contact, interior light (ER5)	309 L	Relay, parking lights (CE19)
205 D	Break contact, interior light (ES5)	309 L	Relay, parking lights (ZB13)
205 D	Break contact, interior light (ZA47)	309 R	Relay, parking lights (CE26)
205 P	Break contact, interior light (ER16)	309 R	Relay, parking lights (ZB13)
205 P	Break contact, interior light (ES17)	312	Relay, starting heater (BL51)
205 P	Break contact, interior light (ZB42)	312	Relay, starting heater (BN51)
207	Closing contact, indicator light, diff. lock, rear wheels (LG23)	313	Relay, bogie lift motor (MA23)
		313	Relay, bogie lift motor (MD33)
207	Closing contact, indicator light, diff. lock, rear wheels (ZB14)	314 A	Relay, bogie lift (LJ7)
		314 B	Relay, bogie lift (LJ13)
207 R	Closing contact, indicator light, diff. lock, rear wheels (LG18)	314 B	Relay, bogie lift (ZB29)
		314 D	Relay, bogie lift (ZB61)
207 R	Closing contact, indicator light, diff. lock, rear wheels (ZB11)	314 D	Relay, bogie lift (MD9)
		315 R	Relay, starting switch (AA42)
211	Closing contact, indicator light, bogie lift (MA16)	315 R	Relay, starting switch (ZB13)
211	Closing contact, indicator light, bogie lift (MD27)	317	Relay, headlamp wiper (GA16)
214	Closing contact, indicator light, low split (NB50)	317	Relay, headlamp wiper (ZB45)



321	Relay, interval wipe (GA27)	3103	Relay, fuel filter heater (HM7)
323	Relay, flasher unit (CN3)	3109	Relay, range restriction (AC11)
323	Relay, flasher unit (ZB29)	3111	Relay, refrigerator (TA13)
326 X	Relay, extra fuse holder (XA13)	3113	Relay, Central lubrication system (TB4)
326 X	Relay, extra fuse holder (ZB54)	3113	Relay, Central lubrication system (ZB24)
327	Relay, heated rearview mirror (HG4)	400 L	Bulb, full beams and dipped beams (CE49)
343	Relay, fog lights, rear (CG12)	400 L	Bulb, full beams and dipped beams (ZA22)
348 A	Relay, fan (HA6)	400 R	Bulb, full beams and dipped beams (CE53)
348 A	Relay, fan (ZB15)	400 R	Bulb, full beams and dipped beams (ZB2)
348 B	Relay, fan (HB37)	401 L	Bulb, fog lights (CG6)
348 B	Relay, fan (HC35)	401 L	Bulb, fog lights (ZA21)
348 B	Relay, fan (ZB2)	401 R	Bulb, fog lights (CG8)
348 B	Relay, fan (ZE32)	401 R	Bulb, fog lights (ZB4)
356	Relay, dipped beams (CE40)	402 L	Bulb, spot lights (CH5)
360	Relay, engage inhibitor, power take-off (LD3)	402 L	Bulb, spot lights (CI5)
360	Relay, engage inhibitor, power take-off (LE4)	402 L	Bulb, spot lights (ZA23)
360	Relay, engage inhibitor, power take-off (ZB11)	402 R	Bulb, spot lights (CH6)
363	Relay, extra equipment (EN8)	402 R	Bulb, spot lights (CI6)
364	Operating controls, bogie lift (MA15)	402 R	Bulb, spot lights (ZB6)
364	Operating controls, bogie lift (MD17)	403	Bulb, loading light (ED6)
364	Operating controls, bogie lift (ZB62)	403	Bulb, loading light (ZA37)
365 D	Relay, electrical window winder, up (KA4)	404	Bulb, fifth wheel light (ED3)
365 D	Relay, electrical window winder, up (ZB38)	404	Bulb, fifth wheel light (ZA37)
365 P	Relay, electrical window winder, up (KA21)	405 L	Bulb, reversing lights (EA8)
365 P	Relay, electrical window winder, up (ZB38)	405 L	Bulb, reversing lights (ZB14)
366 D	Relay, electrical window winder, down (KA16)	405 R	Bulb, reversing lights (ZB20)
366 D	Relay, electrical window winder, down (ZB38)	408	Bulb, parking light, left front (CE14)
366 P	Relay, electrical window winder, down (KA34)	408	Bulb, parking light, left front (ZA21)
366 P	Relay, electrical window winder, down (ZB38)	409	Bulb, parking light, right front (CE32)
379	Relay, injection pump (AC17)	409	Bulb, parking light, right front (ZB6)
3004	Relay, parking heater (ZE33)	410	Bulb, brake light, left (CK9)
3005	Alternator-controlled relay (AA52)	410	Bulb, brake light, left (ZB12)
3005	Alternator-controlled relay (ZB15)	411	Bulb, brake light, right (CK12)
3016	Relay, control device, bogie lift with axle-load limiter (MD25)	411	Bulb, brake light, right (ZB18)
3016	Relay, control device, bogie lift with axle-load limiter (ZB58)	412	Bulb, tail light, left (CE18)
3017	Time relay, axle-load limiter (MD16)	412	Bulb, tail light, left (ZB12)
3017	Time relay, axle-load limiter (ZB58)	413	Bulb, tail light, right (CE26)
3018	Relay, control unit parking heater (HC5)	413	Bulb, tail light, right (ZB18)
3018 A3	Relay, control unit parking heater (ZB2)	414	Bulb, side marker light, left, front (CE12)
3019 A	Relay box, air suspension (ME26)	414	Bulb, side marker light, left, front (ZA21)
3019 A	Relay box, air suspension (MF26)	415	Bulb, side marker light, right, front (CE34)
3019 A	Relay box, air suspension (MG13)	415	Bulb, side marker light, right, front (ZB6)
3019 B	Relay box, air suspension (ME45)	416	Bulb, side marker light, left, centre (CE17)
3019 B	Relay box, air suspension (MF41)	416	Bulb, side marker light, left, centre (ZB13)
3019 B	Relay box, air suspension (MG26)	417	Bulb, side marker light, right, centre (CE29)
3023	Relay, information ABS (CL12)	417	Bulb, side marker light, right, centre (ZB19)
3023	Relay, information ABS (OA13)	420	Bulb, position light, roof, left (CE37)
3023	Relay, information ABS (OB11)	420	Bulb, position light, roof, left (ZA30)
3023	Relay, information ABS (ZB37)	421	Bulb, position light, roof, right (CE9)
3023	Relay, information ABS (ZB48)	421	Bulb, position light, roof, right (ZA29)
3023	Relay, information ABS (ZB54)	422	Bulb, dir. indicator, left, front (CN9)
3070 A	Relay, locking, 3rd axle (LJ23)	422	Bulb, dir. indicator, left, front (ZA23)
3070 A	Relay, locking, 3rd axle (LL5)	423	Bulb, dir. indicator, right, front (CN10)
3070 B	Relay, locking, 3rd axle (LJ32)	423	Bulb, dir. indicator, right, front (ZB4)
3070 B	Relay, locking, 3rd axle (LL16)	426	Bulb, dir. indicator, left, rear (CN14)
3075	Relay, central lock (KH8)	426	Bulb, dir. indicator, left, rear (ZB14)
3075	Relay, central lock (ZA53)	427	Bulb, dir. indicator, right, rear (CN15)
3076	Relay, adjustable seat (HE18)	427	Bulb, dir. indicator, right, rear (ZB20)
3076	Relay, adjustable seat (ZA54)	428	Bulb, rotating warning lamp (EN8)
3101	Relay, interior lighting (ER12)	429	Bulb, cigarette lighter lighting (EV10)
3101	Relay, interior lighting (ES12)	430	Bulb, licence plate light (CE28)
3101	Relay, interior lighting (ZB11)	430	Bulb, licence plate light (ZB18)
3102	Relay, cab tilt pump (HP10)	433 D	Bulb, instep light (ER4)
3102A	Relay, cab tilt pump (NB56)	433 D	Bulb, instep light (ES4)
3102A	Relay, cab tilt pump (NZ54)	433 D	Bulb, instep light (ZA45)
		433 P	Bulb, instep light (ER19)
		433 P	Bulb, instep light (ES19)

433 P	Bulb, instep light (ZB42)	5032	Warning lamp, seat belt (NZ47)
434 C	Bulb, interior light (ER26)	5035	Warning lamp, steering servo circuit 2 (PSS-DUAL) (NB36)
434 C	Bulb, interior light (ES31)		
434 C	Bulb, interior light (ZA22)	5035	Warning lamp, steering servo circuit 2 (PSS-DUAL) (NZ35)
434 L	Bulb, interior light (ER8)		
434 L	Bulb, interior light (ZA39)	600 A	Solenoid valve, exhaust brake (BN44)
434 R	Bulb, interior light (ER13)	600 B	Solenoid valve, exhaust brake (BN46)
434 R	Bulb, interior light (ZA39)	601	Solenoid valve, diff. lock, rear wheels (LG7)
435 L	Bulb, bunk light (ES23)	601	Solenoid valve, diff. lock, rear wheels (ZB50)
435 L	Bulb, bunk light (ZA36)	602	Solenoid valve, diff. lock inter axles (LG5)
435 LL	Bulb, bunk light (ER43)	602	Solenoid valve, diff. lock inter axles (ZB50)
435 LL	Bulb, bunk light (ES40)	603	Solenoid valve, engine shut-down (BN26)
435 LL	Bulb, bunk light (ZA19)	606	Solenoid valve, bogie lift, up (MA5)
435 LU	Bulb, bunk light (ES36)	606	Solenoid valve, bogie lift, up (MD5)
435 LU	Bulb, bunk light (ZA19)	606	Solenoid valve, bogie lift, up (ZA50)
435 R	Bulb, bunk light (ES27)	606 NC	Solenoid valve, bogie lift, up (LJ13)
435 R	Bulb, bunk light (ZA38)	606 NC	Solenoid valve, bogie lift, up (ZB27)
435 RL	Bulb, bunk light (ER46)	606 NO	Solenoid valve, bogie lift, up (LJ8)
435 RL	Bulb, bunk light (ES43)	606 NO	Solenoid valve, bogie lift, up (ZB25)
435 RL	Bulb, bunk light (ZA22)	614	Solenoid valve, range inhibitor (AC7)
435 RU	Bulb, bunk light (ES46)	626	Solenoid valve, exh. pressure governor (BL44)
435 RU	Bulb, bunk light (ZA19)	626	Solenoid valve, exh. pressure governor (BN41)
437 C	Bulb, identification light, front (CE3)	646	Solenoid valve, 3rd axle lock (LJ28)
437 C	Bulb, identification light, front (ZA26)	646	Solenoid valve, 3rd axle lock (LL10)
437 L	Bulb, identification light, front (CE3)	646	Solenoid valve, 3rd axle lock (ZB28)
437 L	Bulb, identification light, front (ZA26)	650	Windscreen wiper motor (GA29)
437 R	Bulb, identification light, front (CE3)	650	Windscreen wiper motor (ZA24)
437 R	Bulb, identification light, front (ZA26)	651	Windscreen washer motor (GA3)
440	Bulb, heater control light (CE39)	651	Windscreen washer motor (ZA43)
440	Bulb, heater control light (ZB55)	652 L	Headlamp wiper motor (GA15)
447	Bulb, ashtray light (EV13)	652 L	Headlamp wiper motor (ZA21)
447	Bulb, ashtray light (ZA27)	652 R	Headlamp wiper motor (GA19)
450	Bulb, roof sign light (EN16)	652 R	Headlamp wiper motor (ZB4)
451	Bulb, rear fog light, left (CG13)	653	Headlamp washer motor (GA9)
451	Bulb, rear fog light, left (ZB12)	653	Headlamp washer motor (ZA43)
452	Bulb, rear fog light, right (CG15)	654	Starter motor (AA14)
452	Bulb, rear fog light, right (ZB18)	654	Starter motor (ZA48)
468	Fluorescent tube, roof lighting (EJ14)	654	Starter motor (ZD16)
468 L	Fluorescent tube, roof lighting (EK14)	656	Bogie lift motor (MA23)
468 R	Fluorescent tube, roof lighting (EK14)	656	Bogie lift motor (MD33)
4052 L	Combination lamp, rear (ZB12)	657	Fan (heater) (HA17)
4052 R	Combination lamp, rear (ZB18)	657	Fan (heater) (ZB14)
4057	Lighting, storage compartment (ER53)	657 ATC	Fan (heater) (HA17)
4057	Lighting, storage compartment (ES60)	660	Alternator with charging regulator (AA22)
500	Indicator light, dir. indicator, tractor (NB41)	660	Alternator with charging regulator (ZA53)
500	Indicator light, dir. indicator, tractor (NZ40)	660	Alternator with charging regulator (ZD21)
501	Indicator light, dir. indicator, trailer 1 (NB42)	661 D	Window winder motor (KA10)
501	Indicator light, dir. indicator, trailer 1 (NZ41)	661 P	Window winder motor (KA27)
504	Indicator light, full beams (NB46)	6013 LF	Solenoid control valve, ABS (OA29)
504	Indicator light, full beams (NZ46)	6013 LF	Solenoid control valve, ABS (OB29)
508	Warning light, parking brake (NB57)	6013 LF	Solenoid control valve, ABS (ZB49)
508	Warning light, parking brake (NZ55)	6013 LR	Solenoid control valve, ABS (OA45)
510	Indicator light, diff. lock, rear wheels (NB37)	6013 LR	Solenoid control valve, ABS (OB45)
510	Indicator light, diff. lock, rear wheels (NZ37)	6013 LR	Solenoid control valve, ABS (ZB52)
511	Indicator light, diff. lock, inter-axles (NB39)	6013 RF	Solenoid control valve, ABS (OA37)
511	Indicator light, diff. lock, inter-axles (NZ38)	6013 RF	Solenoid control valve, ABS (OB37)
547	Central warning for indicator and warning lights (NB44)	6013 RF	Solenoid control valve, ABS (ZB51)
547	Central warning for indicator and warning lights (NZ44)	6013 RR	Solenoid control valve, ABS (OA53)
		6013 RR	Solenoid control valve, ABS (OB53)
		6013 RR	Solenoid control valve, ABS (ZB54)
5009	Indicator lamp, vehicle, ABS (NB54)	6024	Solenoid valve, pto (LD6)
5009	Indicator lamp, vehicle, ABS (NZ52)	6024	Solenoid valve, pto (ZB48)
5010	Indicator lamp, trailer, ABS (NB55)	6024 A	Solenoid valve, pto (LE8)
5010	Indicator lamp, trailer, ABS (NZ53)	6024 A	Solenoid valve, pto (ZB45)
5014	Indicator lamp, split (NB50)	6024 B	Solenoid valve, pto (LE18)
5014	Indicator lamp, split (NZ49)	6024 B	Solenoid valve, pto (ZB47)
5032	Warning lamp, seat belt (NB47)	6035 C	Solenoid valve, level control, electronic (ME13)

6035 C	Solenoid valve, level control, electronic (MF13)	7059	Sensor, outer temperature (NA26)
6035 C	Solenoid valve, level control, electronic (MG7)	7064	Sensor, air pressure-air suspension (ME25)
6035 LF	Solenoid valve, level control, electronic (ME8)	7065	Sensor, accelerator pedal (AC22)
6035 LF	Solenoid valve, level control, electronic (MF8)	7065 A	Sensor, accelerator pedal (AC28)
6045	Solenoid valve, trailing axle (ME21)	7069	Sensor, battery charging (NA29)
6050	Solenoid valve,range restriction (AC12)	7072 LF	Sensor, level control (ME11)
6050	Solenoid valve,range restriction (ZA52)	7072 LF	Sensor, level control (MF11)
6052	Fan motor, parking heater (HB13)	7072 LR	Sensor, level control (ME16)
6052	Fan motor, parking heater (HC18)	7072 LR	Sensor, level control (MF16)
6052	Fan motor, parking heater (ZE14)	7072 RR	Sensor, level control (ME21)
6054	Fuel pump, parking heater (HB2)	7072 RR	Sensor, level control (MF21)
6054	Fuel pump, parking heater (HC2)	7072 RR	Sensor, level control (MG8)
6054	Fuel pump, parking heater (ZE2)	7081	Sensor, boost pressure and boost temperature (BL13)
6055	Coolant pump, parking heater (HC22)	7081	Sensor, boost pressure and boost temperature (BN13)
6056	Motor, levelling control, headlights (PA10)	7082	Sensor, oil pressure and oil temperature (BL23)
6056	Motor, levelling control, headlights (PA4)	7082	Sensor, oil pressure and oil temperature (BN29)
6058 D	Motor, door lock (KH5)	7083	Sensor, fuel pressure and fuel pump (BL3)
6058 D	Motor, door lock (ZA49)	7083	Sensor, fuel pressure and fuel pump (BN3)
6058 P	Motor, door lock (KH13)	7084	Sensor, air filter pressure and air filter temperature (BL8)
6058 P	Motor, door lock (ZB42)	7084	Sensor, air filter pressure and air filter temperature (BN8)
6070	Motor, cab tilt pump (HP10)	800	Starting heater (BL57)
6070	Motor, cab tilt pump (ZA9)	800	Starting heater (BN57)
6071	Injection pump (BN45)	800	Starting heater (ZA54)
6072	Unit injectors, UI (BL29)	802 L	Heated rearview mirror (HG4)
6073	Pump, chassis lubrication, automatic (TB6)	802 L	Heated rearview mirror (ZA28)
6073	Pump, chassis lubrication, automatic (ZB25)	802 R	Heated rearview mirror (HG7)
6103	Solenoid valve, compressor (AC4)	802 R	Heated rearview mirror (ZB21)
702	Combined instrument (NA4)	803	Heated seat (HE7)
702	Combined instrument (NB7)	803	Heated seat (HE12)
702	Combined instrument (NC3)	803 L	Heated seat (ZA31)
702	Combined instrument (NZ15)	803 R	Heated seat (ZA33)
702 A5	Combined instrument (ZA5)	804	Cigarette lighter (ER49)
702 A6	Combined instrument (ZA6)	804	Cigarette lighter (ES49)
702 B	Combined instrument (ZD35)	804	Cigarette lighter (EV8)
709	Combined instrument (NB8)	804	Cigarette lighter (ZA22)
753 A	Engine, speed sensor (BL6)	804	Cigarette lighter (ZA27)
753 A	Engine, speed sensor (BN6)	805	Rheostat (NB20)
753 B	Engine, speed sensor (BL9)	805	Rheostat (NZ20)
754	Pressure sensor air (AC19)	810	Heated air dryer (HK5)
756	Temperature sensor, coolant (BN26)	810	Heated air dryer (ZB22)
756	Temperature sensor, coolant (BL21)	812 D	El. operated rearview mirror (HH3)
757	Fuel gauge sensor (NA18)	812 P	El. operated rearview mirror (HH10)
759	Level indicator, coolant (BL17)	850	Horn (FA7)
759	Level indicator, coolant (BN17)	858	Buzzer, reverse warner (EA14)
763	Level sensor, oil (BL5)	858	Buzzer, reverse warner (EA17)
763	Level sensor, oil (BN5)	858	Buzzer, reverse warner (EA21)
7004	Refrigerator (TA15)	858	Buzzer, reverse warner (ZB12)
7008	Air-operated horn (FA4)	858	Buzzer, reverse warner (ZB15)
7009	Alarm clock/timer (ER30)	858	Buzzer, reverse warner (ZB16)
7009	Alarm clock/timer (ES32)	8001	Inductor, sign lighting (EJ8)
7009	Alarm clock/timer (HB30)	8001	Inductor, sign lighting (EK8)
7009	Alarm clock/timer (HC13)	8001	Inductor, sign lighting (ZA32)
7009	Alarm clock/timer (ZA19)	8015 L	El. operated seat (ZA31)
7009	Alarm clock/timer (ZB4)	8015 R	El. operated seat (ZA33)
7052	Sensor, speedometer (NB21)	8016	Fuel filter heater (HM14)
7052	Sensor, speedometer (NZ10)	8016	Fuel filter heater (ZA19)
7053	Inductive sensor, bogie lift (MD9)	8017	Water separator (HO6)
7053	Inductive sensor, bogie lift (ZB61)	8017	Water separator (ZA63)
7057 LF	Sensor, wheel speed (OA26)	8018 2	El. connected seat (NB47)
7057 LF	Sensor, wheel speed (OB26)	8018 2	El. connected seat (NZ47)
7057 LR	Sensor, wheel speed (OA42)	8018 4	El. connected seat (NB47)
7057 LR	Sensor, wheel speed (OB42)	8018 4	El. connected seat (NZ47)
7057 RF	Sensor, wheel speed (OA34)		
7057 RF	Sensor, wheel speed (OB34)		
7057 RR	Sensor, wheel speed (OA50)		
7057 RR	Sensor, wheel speed (OB50)		
7058 ATC	Sensor, inner temperature (HA22)		

8018 L	El. connected seat (HE6)	9008:4	Control unit, ABS (ZB32)
8018 L	El. connected seat (HE18)	9008:9	Control unit, ABS (ZB32)
8018 L4	El. connected seat (ZA31)	9008:10	Control unit, ABS (ZB38)
8018 R	El. connected seat (HE12)	9008:11	Control unit, ABS (ZB43)
8018 R	El. connected seat (HE23)	9008:12	Control unit, ABS (ZB44)
8018 R4	El. connected seat (ZA33)	9009	Control box, air suspension, rigids (ME33)
900	Radio (JA7)	9009	Control box, air suspension, rigids (MF33)
900	Radio (ZB36)	9009	Control box, air suspension, rigids (ZB64)
901 B	Voltage converter (EX11)	9010	Control box, air suspension, tractors (ME44)
901 B	Voltage converter (ZA11)	9010	Control box, air suspension, tractors (MF43)
901 R	Voltage converter (EX4)	9010	Control box, air suspension, tractors (MG18)
901 R	Voltage converter (ZB26)	9010	Control box, air suspension, tractors (ZB62)
901 R	Voltage converter (ZA4)	9012	Current limiter (ZD10)
902 DD	Loudspeaker (JA12)	9026 F	Socket, 12 V (EX14)
902 DP	Loudspeaker (JA15)	9026 F	Socket, 12 V (ZA6)
902 LF	Loudspeaker (JA6)	9028	Contact roller, air bag (KE8)
902 LR	Loudspeaker (JA18)	9029	Termination resistor, comm. bus (AC27)
902 RF	Loudspeaker (JA9)	9070	Control unit, unit injector (BL5)
902 RR	Loudspeaker (JA21)	9070	Control unit, unit injector (BN5)
913	Mobile telephone (ZB33)	9070	Control unit, unit injector (ZA16)
917	Aerial (AA28)	9072	Control unit, air bag (KE7)
952	Magnetic clutch, air conditioning (HA13)	9073	Control unit, air suspension (ME6)
961	Engine/cab heater (HB8)	9073	Control unit, air suspension (MF6)
961	Engine/cab heater (HC7)	9073	Control unit, air suspension (MG4)
961	Engine/cab heater (ZB6)	9073	Control unit, air suspension (ZB58)
961	Engine/cab heater (ZB7)	9074	Control unit, Vehicle ECU (AC4)
961	Engine/cab heater (ZE8)	9074	Control unit, Vehicle ECU (ZB30)
972 L	Lock, bunk (ES58)	9077	Control unit, sun roof (ZA34)
9001	Pressure monitor, bogie lift (LJ5)	9081	Control unit, electronic immobiliser (AA26)
9001	Pressure monitor, bogie lift (ZB29)	9081	Control unit, electronic immobiliser (ZB36)
9006	Glow plug, parking heater (HB29)		
9006	Glow plug, parking heater (HC16)		
9006	Glow plug, parking heater (ZE28)		

# Abbreviations

ABS .....	Antilock brake system	PH-CAB .....	Cab parking heater
ADR-BAS .....	Basic ADR adaption	PH-ENGCA .....	Engine and cab parking heater
ADR-FRA .....	French ADR adaption	PSS-DUAL .....	Power steering system dual
ATC .....	Automatic temperature control	RADT-AR .....	6x2, leaf spring
CABLE-B .....	Tachograph cable, basic	RADT-A6S .....	6x2, drive axle air spring, 3rd axle air spring and steered
CABLE-EC .....	Tachograph cable, European Community	RADT-LA .....	6x2, drive axle leaf spring, 3rd axle air spring and steered
DRIVL2 .....	Two driving lamps	RF .....	Right front
DRIVL2EC .....	Two driving lamps with dipped beam	RHS .....	Right hand side
DRL .....	Day running light	RIGID .....	Platform and tipper truck
EXE .....	Except	RR .....	Right rear
FSS-AIR .....	Front spring system, air	RSS-AIR .....	Rear spring system, air
FSS-LEAF .....	Front spring system, leaf	SI-SPEED .....	Speedometer
GSS-R .....	Range gear shifting	SLCP-BAS .....	Basic version sleeper control panel
HYDRTRAN .....	Hydraulic transmission	SLCP-LUX .....	Luxury version sleeper control panel
L1H1 .....	Short cab	SUSPL-EC .....	Air suspension, electronic control system levelling device
L2H1 .....	Long cab	TRACTOR .....	Semi-trailer tractor
L2H2 .....	Long high cab (Globetrotter)	UADR .....	Without ADR adaption
LF .....	Left front	UMIR-AUX .....	Without exterior mirror features
LHS .....	Left hand side	USLCP .....	Without sleeper control panel
LR .....	Left rear	VT2014 .....	Volvo transmission 2200NM 14 speed
LOCK-CTL .....	Central door locking	WLIFT-EB .....	Electrical window lift, both doors
LOCK-MAN .....	Manual door locking	WLIFT-ME .....	Manual window lift
LOCK-MRP .....	Manual door locking plus remote control of passenger door		
MECHTRAN .....	Mechanical transmission		
MIR-ELOP .....	El. heated and operated exterior mirror		

## Cable colour code

BL .....	Blue	PU .....	Purple
BN .....	Brown	R .....	Red
GN .....	Green	SB .....	Black
GR .....	Grey	VO .....	Violet
I .....	Ivory	W .....	White
LBL .....	Light blue	Y .....	Yellow
LBN .....	Light brown		
OR .....	Orange		
P .....	Pink		

**Note:** If a cable has two colours, this is written out like the following example: Y/R = Yellow/Red.



**VOLVO**  
Volvo Truck Corporation  
Göteborg, Sweden