

*Operation*  
AND  
*Maintenance*



*Ferguson Tractor*

MODEL TO-20

**HARRY FERGUSON, INC.**  
**DETROIT, MICH.**



**HARRY FERGUSON, INC.**

**TRACTOR**

*Warranty*

---

For a period of ninety (90) days from the date of delivery of a new Ferguson Tractor to the original purchaser thereof from a Ferguson dealer, Harry Ferguson, Inc., warrants all such parts thereof (except tires) which, under normal use and service, shall appear to Harry Ferguson, Inc., to have been defective in workmanship or material.

This warranty is limited to shipment to the purchaser, without charge except for transportation costs, of the part or parts intended to replace those acknowledged by Harry Ferguson, Inc., to be defective.

If the purchaser uses or allows to be used on the Ferguson Tractor, parts not made or supplied by Harry Ferguson, Inc., or if any Ferguson Tractor has been altered outside of its own factories or sources of supply, or if implements have been used which were unsuited and harmful to the Ferguson Tractor, then this warranty shall immediately become void. Harry Ferguson, Inc., does not undertake responsibility to any purchaser of a Ferguson Tractor for any undertaking, representation or warranty beyond those herein expressed.

Harry Ferguson, Inc., reserves the right to make changes in design or changes or improvements upon the Ferguson Tractor without any obligation upon it to install the same upon its tractors theretofore manufactured.

# INDEX

ACCESSORIES .....	37	Implements	
ADJUSTING WHEEL		Attaching .....	28
TREAD WIDTHS .....	11	Listing .....	48
Air Cleaner .....	8, 17	LUBRICATION & INSPECTION	6
Antifreeze .....	24	Linkages .....	29
Attaching Implements .....	28	MAINTENANCE & SERVICE	12
Axle—Front .....	8, 11, 12	Master Control Spring .....	29
—Rear .....	30	OILING SYSTEM .....	16
Battery .....	8, 20	OPERATING INSTRUCTIONS	9
Belt Pulley .....	8, 33, 45	Overload Warning .....	46
BRAKING SYSTEM .....	31	POWER TAKE-OFF .....	9, 33, 45
Brakes .....	9, 45	Radiator .....	8, 23
Break-in Periods .....	10	REAR AXLE & DIFFERENTIAL	30
Capacities .....	45	SAFETY RULES .....	38
Carburetor .....	8, 18	STORAGE .....	37
Choke .....	9	Serial Number—Engine .....	3
Clutch .....	9, 25	—Tractor .....	3
Controls .....	9	Spark Plugs .....	22
COOLING SYSTEM .....	23, 44	SPECIFICATIONS .....	43
Differential .....	30	Speeds—Pulley .....	34
Distributor .....	21	—Engine .....	19
Drawbar .....	29	—Operating .....	44
ELECTRICAL SYSTEM .....	20	—Power Take-Off .....	34
Engine .....	14, 43	Starter .....	9, 22
Engine Serial Number .....	3	STARTING TRACTOR .....	10
Fan .....	23	Steering .....	8, 13, 45
FERGUSON SYSTEM .....	27	TRACTOR TIRES .....	8, 35, 45
FERGUSON ENGINE .....	14	Tire Pressure Table .....	35
Finger Tip Control .....	9, 29	Timing—Valves .....	15
FRONT AXLE AND		—Distributor .....	21
STEERING .....	12, 13	Thermostat .....	23
FUEL SYSTEM .....	17, 44	Tread Widths .....	11
Gas Tank .....	8, 17	TRANSMISSION & CLUTCH	25
Gearshift Lever .....	9	Transmission .....	8, 44
Generator .....	8, 21	TROUBLE SHOOTING .....	39
Governor .....	19	Valve Adjustment .....	15
Hood .....	9	Voltage Regulator .....	22
HOW TO START TRACTOR	10	WARRANTY .....	47
Hydraulic System .....	28, 45	Water Pump .....	24
Ignition System .....	9, 21, 44	Wheels .....	11, 45
		Wiring .....	20

# Foreword

● This book has been written for *YOU* — the purchaser of a new Ferguson Tractor. For your confidence in us and our product we sincerely thank you.

Your new Ferguson is as fine a tractor as it is possible to produce. Because it is a precision-built unit, the knowledge of certain fundamentals will help you obtain the most from both the tractor and its equipment. That is the purpose of this book.

Brief suggestions will enable you to make ordinary adjustments. For major repairs, we urge you to consult your dealer. He knows the Ferguson Tractor inside and out . . . has both the experience and equipment for the most satisfactory service.

May we wish you more economical and enjoyable farming with your new Ferguson Tractor!

**HARRY FERGUSON, INC. • DETROIT, MICHIGAN**

YOUR FERGUSON DEALER \_\_\_\_\_

ADDRESS \_\_\_\_\_

PHONE \_\_\_\_\_

TRACTOR SERIAL NO. \_\_\_\_\_

(Located—Top of Steering Column)

ENGINE SERIAL NO. \_\_\_\_\_

(Located—Left Side of Steering Block)

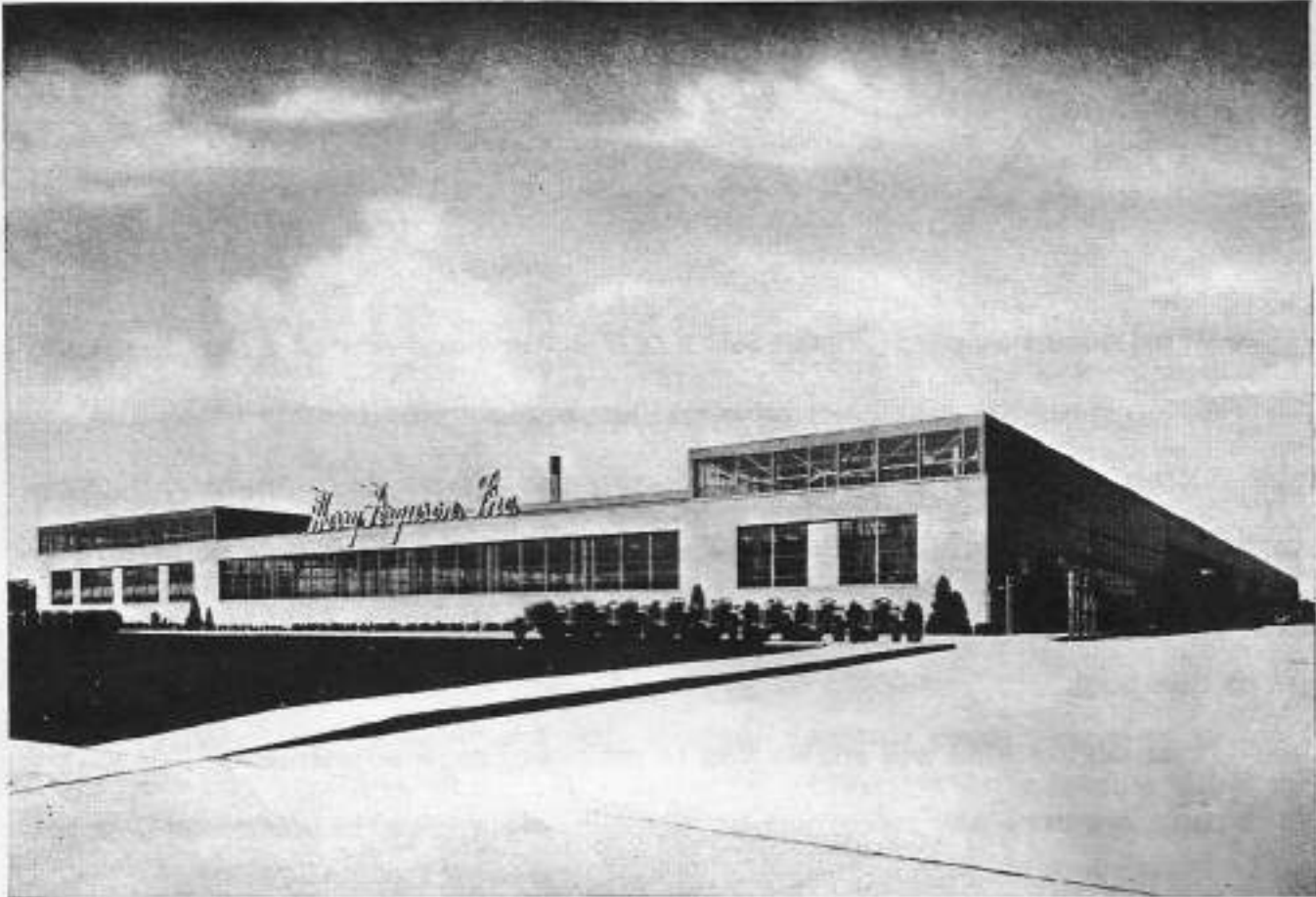

# *Ferguson Park*

## **WHERE YOUR TRACTOR WAS BUILT**

● In this modern plant, on Southfield Road in Detroit, your new Ferguson was built. This site occupies more than 72 acres. When the development of Ferguson Park is completed, the installation will be the most modern and complete of its kind . . . housing not only manufacturing operations, but the general offices, parts and service and other departments of Harry Ferguson, Inc. Whenever you're in Detroit, you will be welcome at Ferguson Park.

# THE *Ferguson Tractor*

## WITH *Ferguson Hydraulic System*

**The Perfect  
Farming  
Combination**

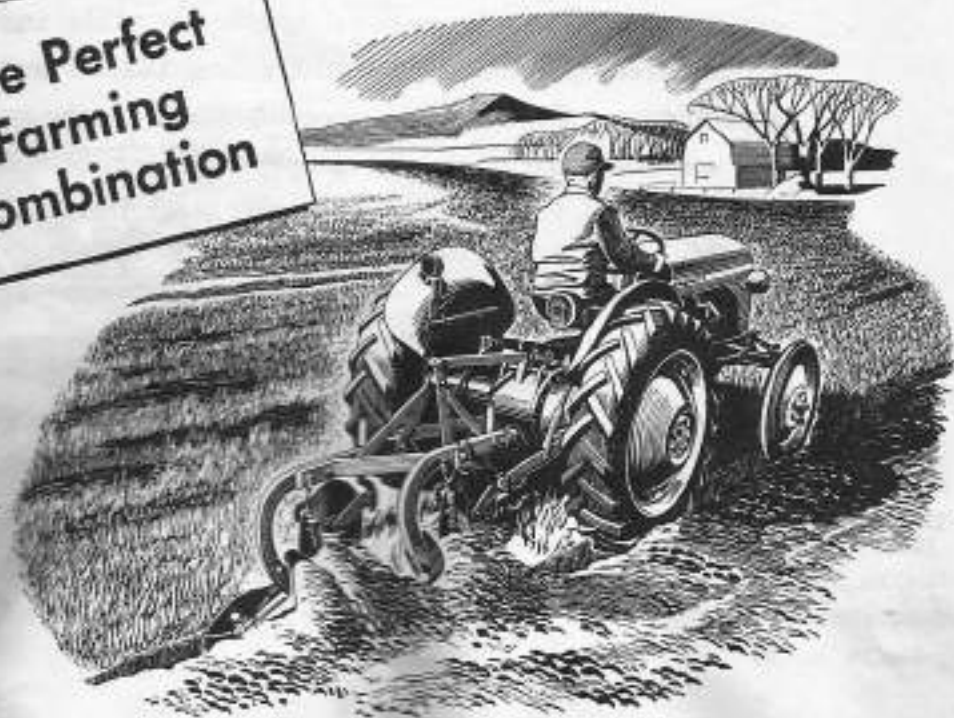

● Your Ferguson Tractor is a precision-built unit designed for efficient performance, economy and ease of operation. It is extremely rugged . . . capable of giving outstanding service.

This tractor is especially designed to take full advantage of the Ferguson System. (See pages 27 to 29 for complete description.) Whatever your requirements may be, your Ferguson Tractor and its hydraulically-controlled implements will open up a new, more modern way of farming.

# Lubrication and Inspection.

Proper maintenance, including periodic inspection and regular lubrication is essential to the long life and trouble-free operation of your Ferguson Tractor and its equipment. On this and succeeding pages are shown the essential instructions for proper maintenance and lubrication of your tractor at regular work intervals.

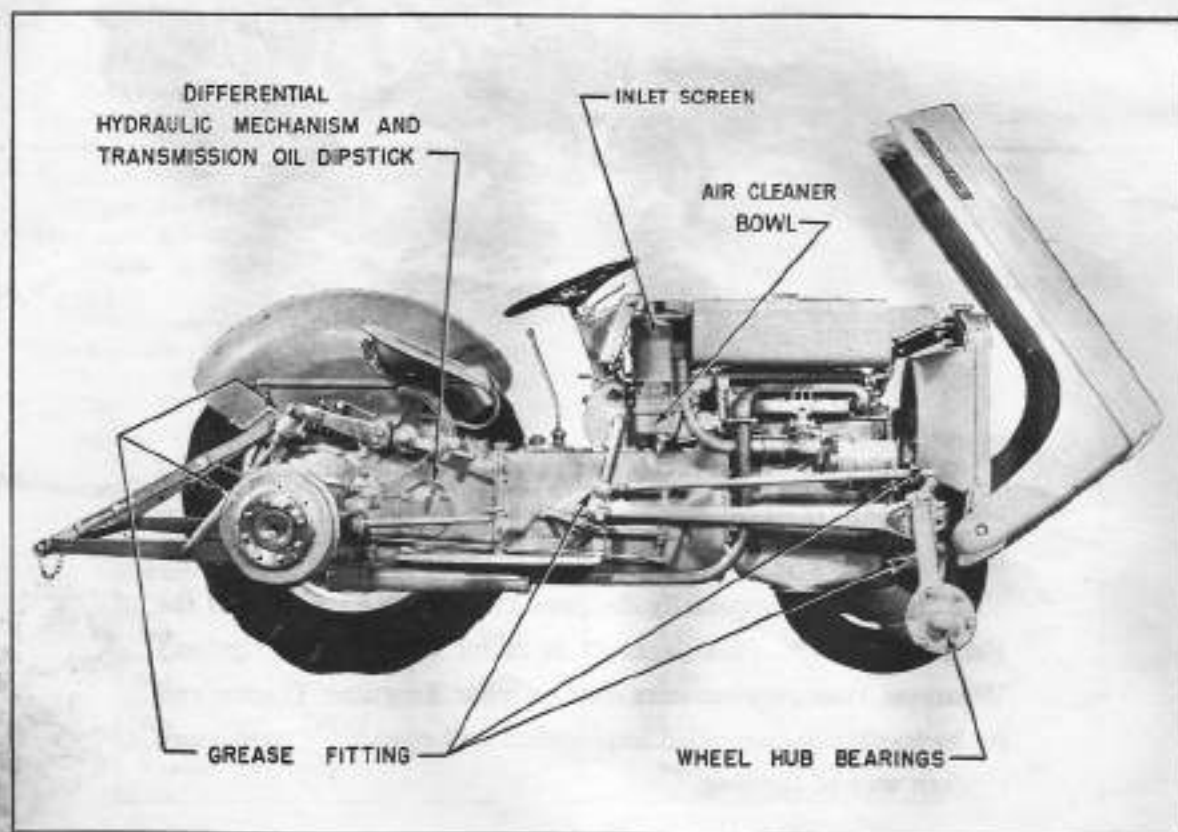

Right side of tractor, showing lubrication and maintenance points.

## KEY TO LONG LIFE AND ECONOMY

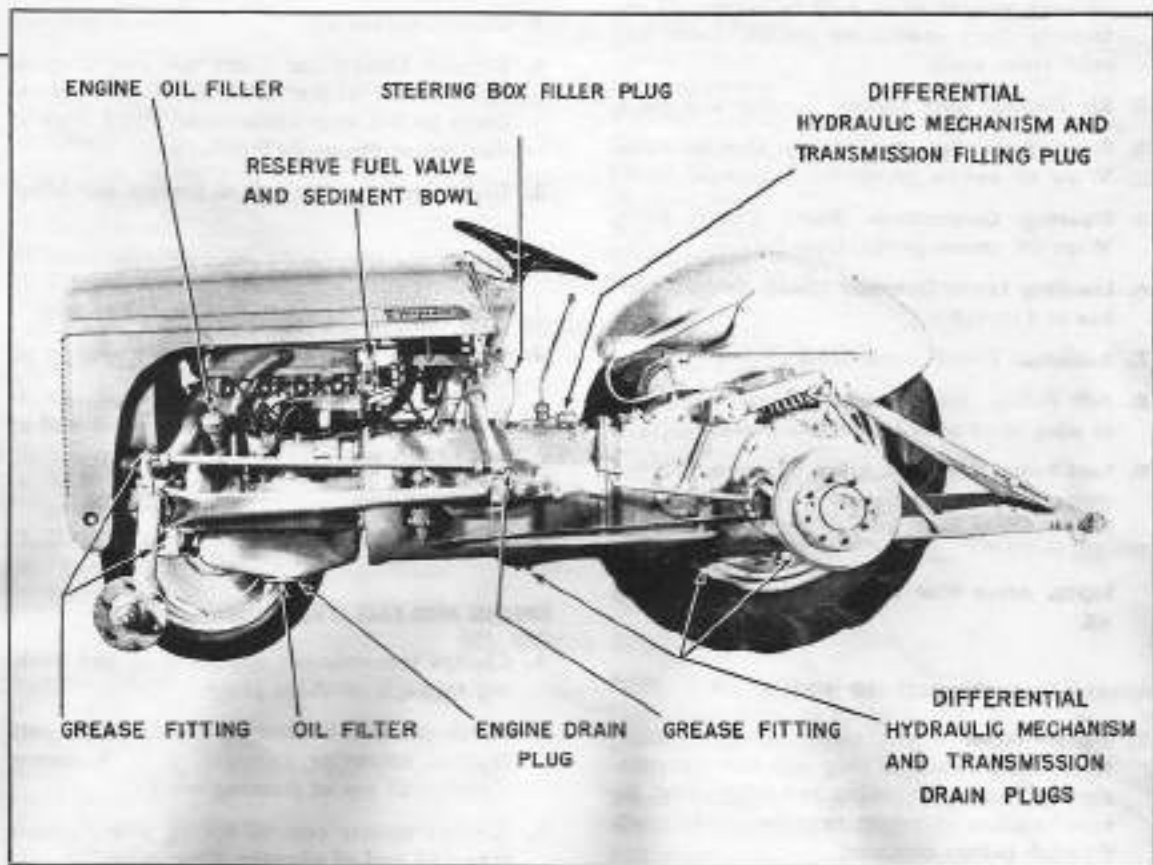

Left side of tractor, showing lubrication and maintenance points.

### ENGINE LUBRICATION

Capacity 6 U. S. quarts (5 Imperial quarts). Fill with SAE-30 for temperatures above 50°F. Use SAE-20 for temperatures below 50°F. For temperatures below 10°F. use SAE-10W.

**NOTE:** When installing a new oil filter cartridge, change engine oil and add one extra quart.

### TRANSMISSION, HYDRAULIC SYSTEM AND DIFFERENTIAL

Use straight mineral gear oil SAE-90 for temperatures above 50°F. and the same oil in

SAE-80 for temperatures below 50°F. All oil companies merchandise this type oil.

**WARNING:** More harm can be done to a tractor in 100 hours with an inferior or wrong type oil than could be done in thousands of hours with the correct oil. Insist on obtaining and using the oil specified.

**NOTE:** Keep tractor on light work for first 50 hours.

### DAILY MAINTENANCE AND LUBRICATION (EVERY 10 WORK HOURS)

1. Check engine oil level to full mark on dipstick. Do not overfill.



2. **Air Cleaner Bowl.** Clean and refill, using oil of same weight as is used in engine. If extremely dirty conditions prevail, clean and refill twice daily.
3. **Air Cleaner Inlet Screen.** Inspect and clean.
4. **Front Axle Spindles (two).** Grease daily. Wipe off excess grease from fittings.
5. **Steering Connections (four).** Grease daily. Wipe off excess grease from fittings.
6. **Leveling Lever Gearbox (two).** Grease gearbox and thread.
7. **Radiator.** Check water level.
8. **Belt Pulley.** (Not standard equipment.) Fill to plug level with transmission oil.
9. **Fuel Tank.** Use good, clean gasoline, pouring through screened funnel or clean chamois. *When filling tank, stop engine!*

**NOTE:** After first 30 hours—change engine oil.

#### WEEKLY MAINTENANCE (50 HOURS)

1. **Transmission.** Check oil level on dipstick. Keep filled. A single plug supplies transmission hydraulic mechanism and differential. Be sure to allow sufficient time for oil to reach dipstick before checking.
2. **Generator.** 10 drops of light oil in oiler. (Do not oil excessively.)
3. **Carburetor.** Shut off fuel valve, then remove drain plug and drain carburetor. Remove and clean sediment bowl and filter.
4. **Battery.** Examine battery and, if corroded or dirty, clean top with soft-water-and-soda solution. Check water level—keep filled above plates with distilled water.
5. **Tires.** Pressure—front 26 lbs., rear 12 lbs.

**NOTE:** Change transmission lubricant in new tractor after first 100 hours. Remove drain plugs (three) from transmission, hydraulic mechanism and differential. When draining, put control lever in "down" position (so oil will drain from the ram cylinder).

#### BI-MONTHLY MAINTENANCE (EVERY 150 HOURS)

1. Change engine oil.
2. Remove Distributor Cap; put one drop of light oil on breaker lever pivot, and several drops on felt wick under rotor. Put a trace of distributor grease on breaker cam.
3. Grease battery terminals to prevent corrosion.

#### MONTHLY MAINTENANCE (300 HOURS)

1. Clean spark plugs. Set gaps to .025 inches.
2. Change oil filter cartridge (every second oil change).
3. Tighten six bearing retainer nuts on end of rear axle housings.
4. Tighten all bolts, nuts and screws.
5. Clean radiator and grille.

#### SPRING AND FALL (750 HOURS)

1. Change transmission oil, draining and flushing through all three plugs.
2. Check oil level in steering housing and refill. Normal operating capacity, 2 U. S. quarts (level with top of steering arm).
3. Remove master control spring yoke; grease threaded end of plunger. (See page 28.)
4. Flush and clean radiator. (See page 24.)

#### YEARLY MAINTENANCE

1. Wash out front hub bearings with kerosene and repack with short fibre grease.
2. Renew front hub dust seal if condition warrants.
3. Wash tractor thoroughly. Remove rust spots; touch up areas with Ferguson paint.

**NOTE:** On a Ferguson Tractor these points do not require lubrication: Front Axle Center Pivot Pin, Clutch Connections, Brake Lever Pins and Bearings, Linkage Ball Joints or Pins, Throttle Connections, Engine Water Pump and Fan.

# Operating Instructions

All controls of your Ferguson Tractor are within convenient reach of the operator. The accompanying illustration shows the various controls of the tractor and is keyed for your convenience.

**A—Ignition Switch.** Operated by key on lower left side of instrument panel. (Tractor ignition can be locked if desired.)

**B—Hood Release.** Lower left side of instrument panel, near ignition switch. (To lower, trip latch at hinge point.)

**C—Clutch Pedal.** Located on left side of transmission housing.

**D—Left Wheel Brake Pedal.**

**E—Right Wheel Brake Pedal.**

**F—Master Brake Pedal.** Simultaneously controls both brakes.

**G—Master Brake Pedal Pawl.** Enables operator to lock pedal Master Brake in any position.

**H—Choke.** Choke button on the lower right-hand side of the instrument panel.

**I—Shift Lever.** Located on transmission housing ahead of tractor seat. Various gear speeds are indicated by raised numerals on the transmission housing cover.

**J—Starter Switch.** The safety starter switch is operated by the gear-shift lever I. It is impossible to start engine when tractor is in gear.

**K—Throttle.** On right side of steering column. (For adjustment, see "Governor", Maintenance Section, page 19).

**L—Oil Pressure Gauge.** Right side of instrument panel. Normal reading approximately 25-35 lbs. per square inch at full throttle. Always check for adequate oil pressure.

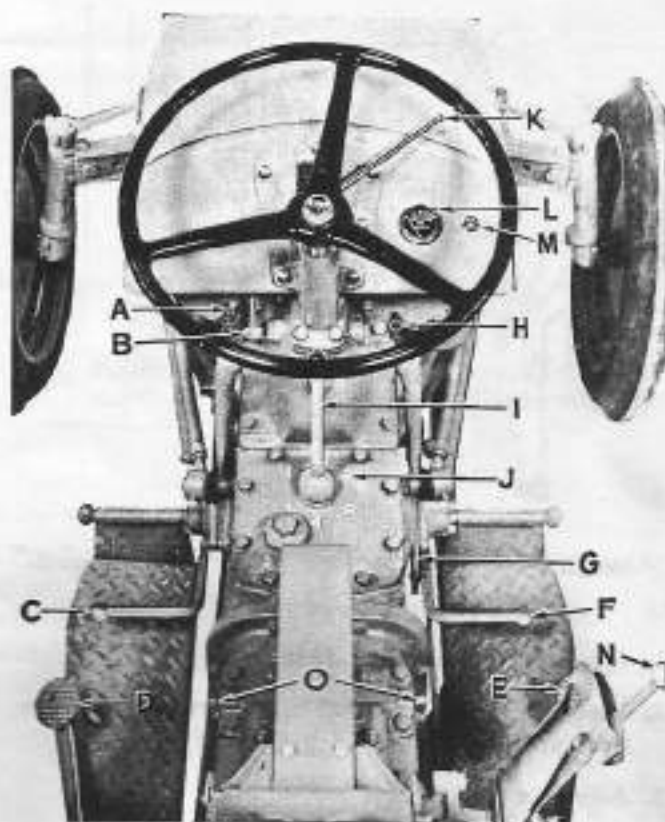

**M—Charge Indicator Light.** Right side of instrument panel. Light comes on if generator is not charging.

**N—Finger Tip Control Lever.** Controls hydraulic system. *Always lock in "down position" when drawbar stays are in place.*

**O—Twin Hydraulic Pump Outlets.** For use with tools and equipment requiring external hydraulic pressure.

**P—Power Take-off Lever (in engaged position)**

—Lever must be in position shown before hydraulic system or power take-off can be operated. Lever is part of inspection plate assembly on left side of center housing.



# Starting AND Breaking-In



*"Always open doors before starting the engine."*

1. Open fuel valve by turning fully to the left;
2. Insert ignition key and turn to right. (Charge indicator light should glow red);
3. Advance throttle  $\frac{1}{4}$  open;
4. Pull out and hold choke in open position;
5. Disengage clutch (push pedal down) and engage starter by lifting gearshift lever and moving to right and forward to "Start" position (indicated on transmission housing by "S"). This starts engine cranking;
6. Release choke when engine starts. Charge indicator light will go out when generator starts charging.
7. Don't race engine immediately after starting—give the oil a chance to circulate freely. Oil pressure gauge should register 25-35 lbs. at full throttle.
8. Allow engine to thoroughly warm up before working tractor. This eliminates condensation and formation of sludge and corrosion which cause rapid wear of moving parts.

A double hinge provides two more positions of tractor seat for comfort of operator.

## BREAK-IN

1. Keep your tractor on light work for initial 50-hour break-in period. A properly broken-in tractor will give better service, greater economy and improved, heavy-duty operation.
2. Change crankcase oil after first 30 hours.
3. Change transmission oil after first 100 hours.
4. Call dealer for 100-hour tune-up.
5. Tighten all nuts, bolts and screws.



*"Keep hay, straw, inflammable material away from exhaust pipe to prevent fire."*



# Adjusting Wheel Tread Widths

The different work you will do with your Ferguson Tractor will require various tread-width adjustments. These adjustments are simply made, due to the unique design of your Ferguson Tractor.



Wide tread width for row-crop operation.

The front wheels may be adjusted—in 4-inch steps—from 48 to 72 inches by assembling the three-section front axle in various lengths. Even when the front axle is fully extended, an addi-



Adjusting front wheel tread width.

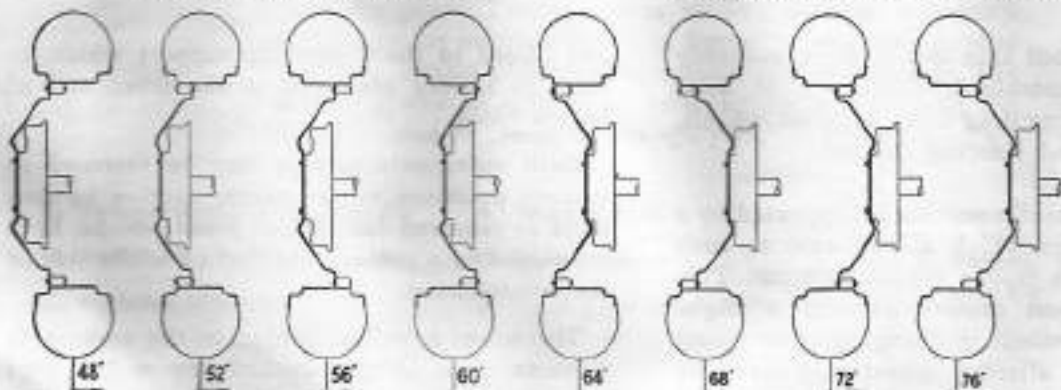

REAR WHEEL TRACK SETTINGS FOR FERGUSON TRACTOR

tional 4-inch width on either side may be obtained by removing and turning the front wheels so that the wheel-dish is on the inside. This gives a total spread of 80 inches. To obtain a 76-inch tread, leave the wheels in this 80-inch position, but move the two outer axles in one hole on the center sections. Do not operate with the front wheel



Adjusting rear wheel tread width. Note use of Ferguson Power Jack.

discs turned out unless necessary, since this throws an additional load on the outer front wheel bearings.

**Note:** In adjusting front axle, always leave at least one bolt hole between the two bolts to prevent undue strain on front axle.

**REAR WHEEL WIDTH SETTINGS** Rear wheel tread settings may include 48, 52, 56, 60, 64, 68, 72 and 76 inches. To obtain rear tread widths of 56, 60, 72 and 76-inch intervals, switch wheels to the opposite side and adjust according to diagram. The tire side wall arrow should always point in the direction of travel. For normal plowing operations set wheel widths at 52 inches.

Diagram reveals the rear wheel tread settings. Note that wheels are switched to obtain 56, 60, 72 and 76-inch intervals.

# Maintenance and Service

## SECTION

While we recommend that major overhauls, replacements and adjustments be done by the dealer whenever possible, occasions may warrant the owner making minor repairs and adjustments. For that reason, the following material has been compiled to give you a working knowledge of your Ferguson Tractor.

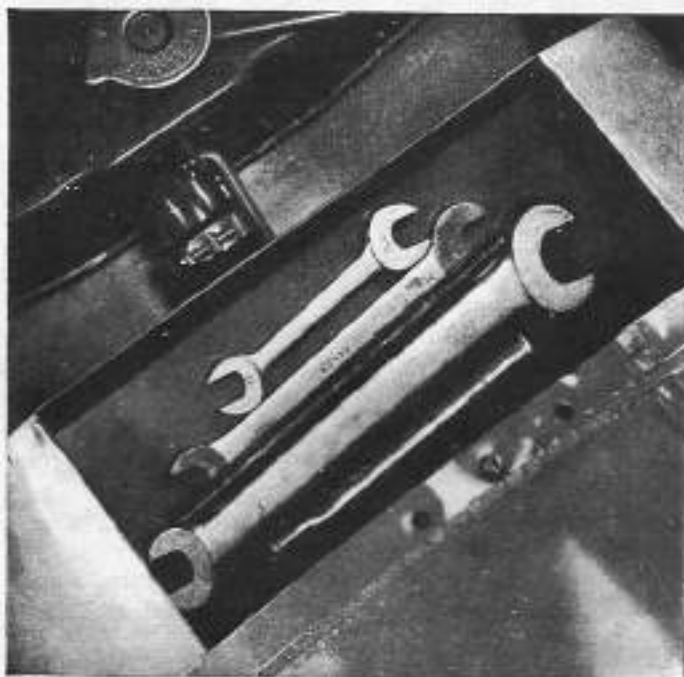

The tool box of your Ferguson Tractor, located under the hood, just back of the radiator.

---

## Front Axle and Steering Assembly

The Ferguson front axle and steering assembly include the adjustable tri-section front axle, radius rods, steering drag links, spindles, wheels, steering wheel and steering column.

**Front Axle.** The center section is supported by a  $1\frac{3}{4}$ -inch pivot pin which allows axle to rock slightly as wheels follow ground contour. This exclusive Ferguson feature permits a slight front-to-rear movement in changing front wheel spacing without altering wheel alignment or steering geometry. The pin itself is pressed in

and bolted to the front axle support which, in turn, is solidly anchored to the front end of engine block.

Each outer axle section may be fastened in various positions to the center section by two bolts as required for various tread widths. It is supported by a radius rod attached to the side of the transmission.

The wheel spindles, housed in the outer axle sections, turn in steel-backed bronze bushings pressed into top and bottom of the housing.

Weight is transferred from axle to spindle through a thrust bearing at the lower end of the axle.

The front wheel, consisting of hub and wheel disc with standard 6-inch bolt circle, is mounted on the spindle with two tapered roller bearings. The wheel discs have a 2-inch offset, permitting



Measuring correct toe-in.

an additional 4-inch outward movement, if either wheel is reversed—or an 8-inch outward movement, if both wheels are reversed.

**Steering Gear.** The specially designed Ferguson steering gear makes possible use of the adjustable three-section front axle. The pinion operates two sectors simultaneously—one moving forward and the other backward—the same distance. These sectors, in turn, control the position of the steering arms, drag links and front wheels. Because both the radius rods and the drag links are the same length and operate in the same plane, they move in the same arc as the wheel spacing is changed. Thus the wheel alignment and the steering geometry remain unchanged.

Clearance between pinion and the sectors is controlled by two adjusting screws (one on either side), which contact the back of, and hold the sector fully meshed with the pinion gear. A lock-nut holds each screw firmly in position.

**Steering Lubrication.** Add transmission oil to bring oil level to top of steering arm. Check level each year (normally, oil should not require changing). Changing oil will require either removing housing from tractor and draining by

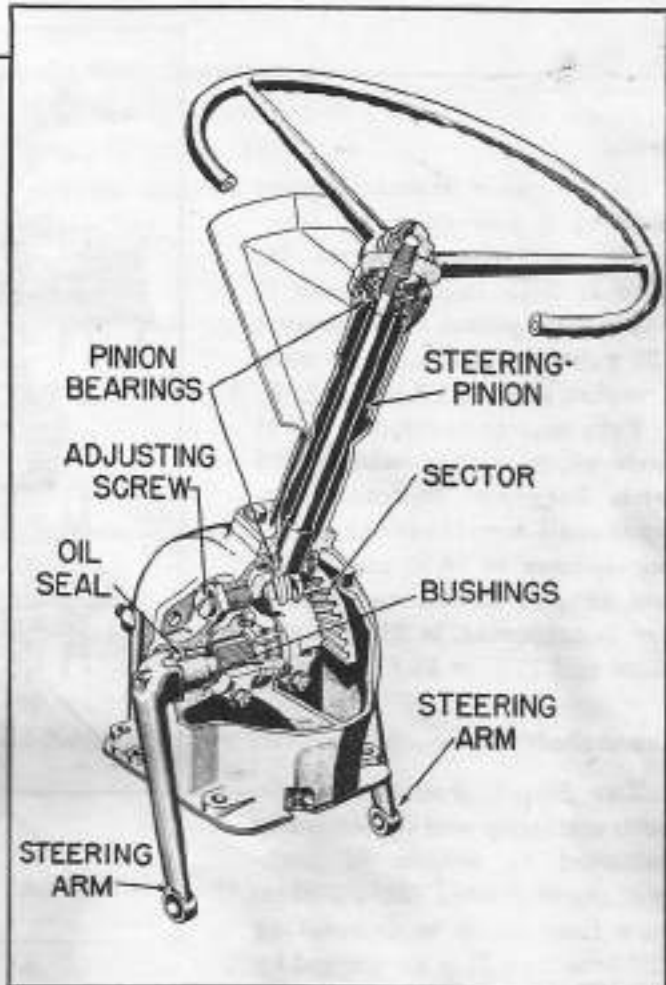

removing plate beneath or sucking oil out through filler cap hole with suction pump. The pinion shaft bearings are completely lubricated at time of manufacture.

**Servicing.** Other than adjustments to meet operating conditions, servicing requirements are simple. Grease spindles and steering joints daily during operation. Each year, or oftener, depending upon operation, remove wheels, wash bearings and pack with a short fibre grease.

Wheel bearings should be adjusted so that wheel shows a slight drag when rotated freely . . . then back off adjusting nut one notch and install cotter key.

Periodically check wheel alignment for toe-in of "0" to  $\frac{1}{4}$  inch (measured between tire rib centers at hub height). To adjust, loosen clamp bolts at back and front of either drag link and turn link in or out as required—then tighten clamp bolts.

Your Ferguson Tractor is powered by a four-cylinder, four-cycle, wet sleeve engine. Its bore is  $3\frac{9}{16}$  inches, stroke is  $3\frac{3}{4}$  inches, piston displacement 120 cubic inches, and the compression ratio is 6.1 to 1.

Your tractor is rated as a 2-14 inch plow tractor when used with Ferguson hydraulically-operated implements. Belt horsepower is 26.50 maximum, and 85% or 22.53 rated. Drawbar horsepower is 21.77 maximum and 75% or 16.33 rated.

### Crankshaft (A)

The drop-forged crankshaft, both statically and dynamically balanced to within  $\frac{3}{4}$  inch-ounces, is drilled for oil pressure from main to connecting rod bearings. It is supported by three main bearings with replaceable liners. End thrust is taken by the front main bearing.

### Connecting Rods (B)

The forged steel connecting rods are balanced so there is, at most, no more than  $\frac{3}{4}$  ounce variation in weight between any two of them.

### Pistons (C)

Cam-ground aluminum alloy pistons are matched with their respective sleeves at the factory—are replaced as an assembly. Arrow on head indicates correct placement of piston in cylinder—should always point to front of engine.

### Piston Rings (D)

There are three compression rings and one oil control ring—all made of close-grained cast iron. Top compression ring has beveled outer edge

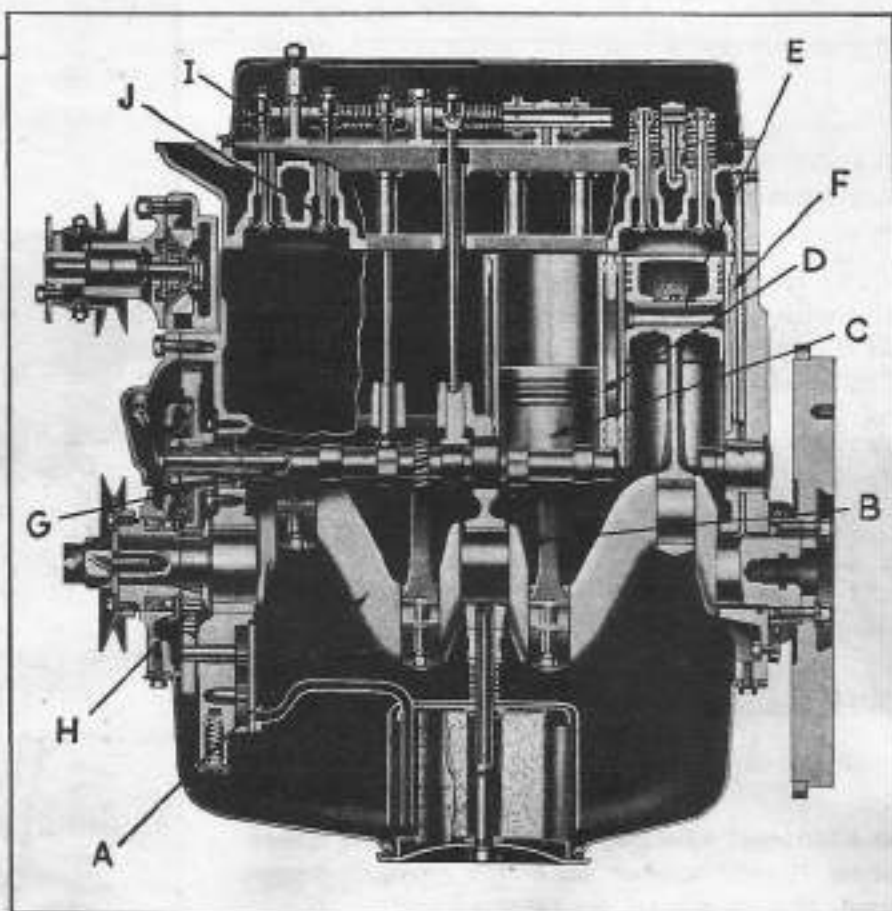

Right side of Ferguson Engine

and top inner side has 30° bevel. All rings are stamped "top" for correct assembly **and are not interchangeable.**

### Piston Pins (E)

Full-floating type, made of cold drawn steel tubing and secured at both ends by snap rings.

### Sleeves (F)

Sleeves are centrifugally cast of uniformly grained cast iron, easily pressed into position in block. They are sealed against leakage at the bottom by two neoprene rings. They project from .002 to .005 inches above cylinder top so that the head and its gasket hold them securely in position.

### Camshaft (G)

The cast alloy camshaft turns in three ground bearings in the cast-iron engine block.

### Timing Gears (H)

Both the steel crankshaft and camshaft gears are available in three sizes—"standard", "undersized" and "oversized". Gears are stamped to indicate size—an "S" for standard, "O" for over-size and "U" for undersize—followed by a number to show amount of over or undersize.

The cam gear section of block is also stamped to indicate original installation with an "S", "+", or "-", followed by a number to show amount of over or undersize. When replacing both gears on block marked "+1", use one standard and one .001-inch oversize. When replacing one gear after considerable use, the next larger gear should be used to give a .001-inch tight fit to take up wear.

### Rocker Arms (I)

Rocker arms operate on a shaft which receives oil from rear main bearing and distributes it to rockers through drilled holes in shaft. They are fitted with steel-backed, babbitt-lined bushings, and are assembled with radial groove toward push rod side. The rocker arm shaft is assembled with drilled holes facing valve springs.

### Valves (J)

Of one-piece construction, the valves have a 45-degree seat-angle.

**Note:** In reassembling, exhaust valve should just be closed and intake valve should be ready to open, with piston at top dead center following exhaust stroke.

## VALVE ADJUSTMENT

Proper valve adjustment is essential for quiet, smooth operation and long valve life. Check and adjust as follows:

1. Remove gas tank and cylinder head cover.
2. Remove spark plugs.
3. Rotate engine with crank until number 1 piston reaches exact top dead center compression. (Compression stroke is determined by extreme pressure from #1 spark plug hole when hole is covered with thumb.)
4. Remove Timing Hole Button Plug (back of left engine flange) to verify top dead cen-

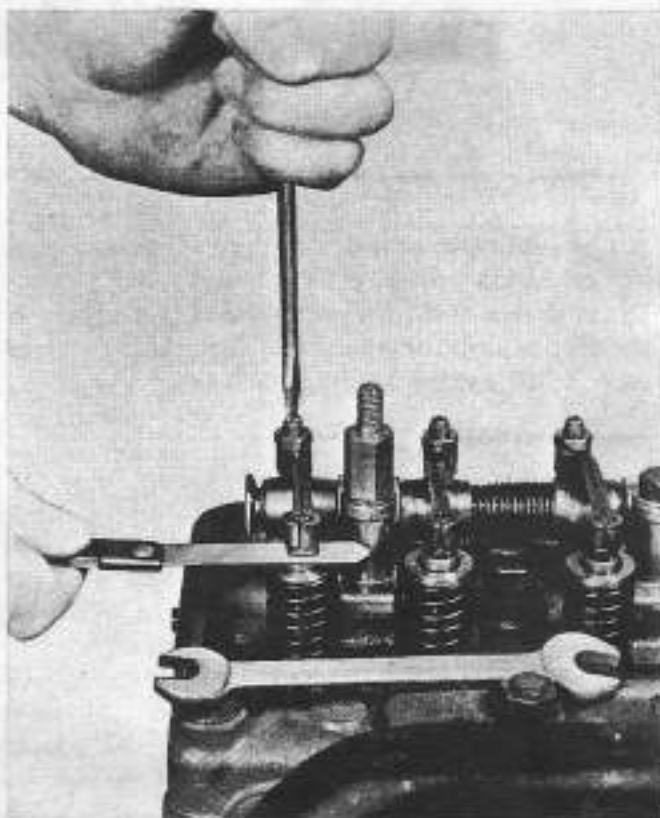

Showing how feeler gauge is used to adjust valve tappet clearance.



Removing timing hole button plug

ter of #1 cylinder. After compression is felt, turn slowly with crank until graduated line, indicated by letters "D.C." on flywheel, is aligned with groove in timing hole.

5. Set both valves with engine cold at .014.
6. Engine firing order is 1-3-4-2. Set other valves by following foregoing procedure.
7. Recheck valves with engine operating at slow idle speed, using a .013-inch feeler gauge.



# ENGINE *Oiling System*

• The crankcase capacity of the full-pressure oiling system is 6 U. S. quarts, (5 Imperial quarts). Oil is drawn from the sump through a screen in the oil pan into the pump, and forced, under pressure, to all engine bearing surfaces.

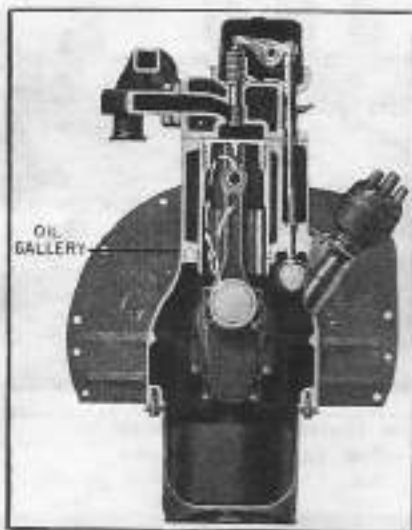

Position of oil gallery and connecting rod spurt holes for lubricating cylinder walls. Oil returns from the cylinder head through the push rod tubes.

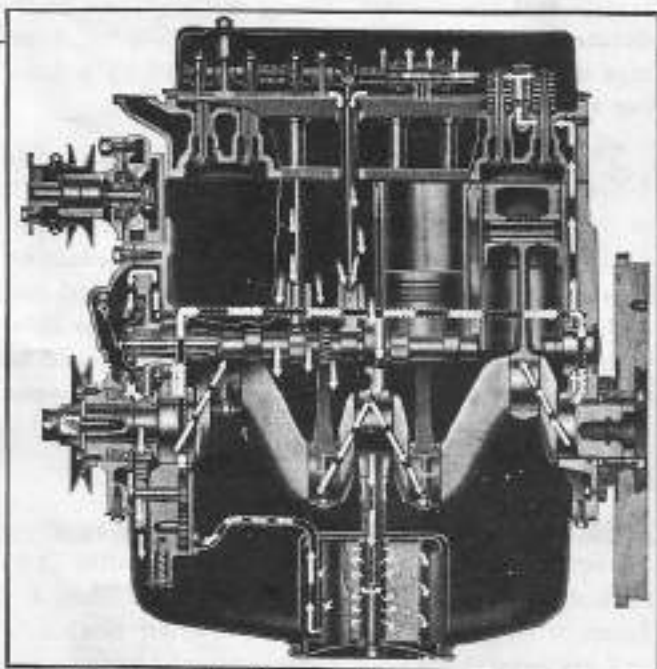

Phantom photo of Ferguson Tractor engine shows forced oil circulation to all vital engine points.

From the front main bearing, oil passes through the drilled crankshaft to the front connecting rod bearing and front camshaft bearing, being metered through the camshaft retaining plate to the governor and timing gears. Oil from the gallery passes to the center main bearing and through the crankshaft to the second and third connecting rod bearings. The rear main bearing is also lubricated from the oil gallery through the rear connecting rod and camshaft bearings.

A passage leading from the rear main bearing to the rear support of the rocker arm shaft provides lubrication from the rocker arm bushings and valves. On the return through the push rod holes, it lubricates cams, tappets and center camshaft bearing. Another tube carries the oil from the center main bearing through the oil filter where it is cleaned.

**OIL FILTER** The oil filter, located in the engine pan, removes dirt, water, sludge, carbon, grit, dust, metal and other foreign particles. Its position in the bottom of the sump eliminates all external oil lines, and its efficiency is increased because it operates at engine oil temperature. Its care is important to insure long engine life and lower maintenance costs.



Removing oil drain plug from crankcase.



Removing oil filter and screen.

Change engine oil every 150 hours, draining it from the bottom of the crankcase. Change oil filter cartridge every 300 hours. Use only an *inside-to-outside* type filter cartridge. To replace cartridge, drain oil, remove cover and withdraw used cartridge and wash screen. *Add one extra quart of oil when new filter cartridge is installed.* To prevent leaks due to gasket stretching, firmly shellac filter cover gasket to pan or gasket cover.

**OIL PUMP** The engine oil pump is of the single-stage gear type, and is located on the lower side of the front main bearing. A relief valve in the pump body by-passes oil when pressure builds up to 25-35 p.s.i.

**OIL SEALS** Engine oil losses are prevented by oil seals at both ends of the crankshaft. Use care in replacing oil seals to insure proper sealing.

# Fuel System

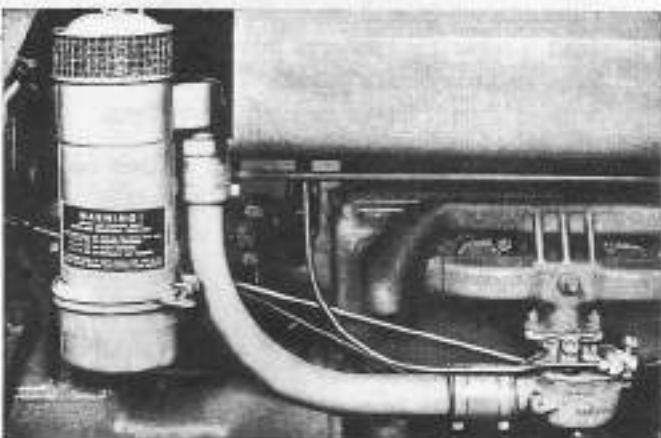

Air cleaner, air intake and carburetor



Clean air-cleaner screen daily for best engine operation.



Air-cleaner bowl should be removed and cleaned daily.

Your tractor fuel system includes a fuel tank under tractor hood (capacity: 10 U.S. or 8.3 Imperial gallons), fuel sediment bowl-and-filter, air cleaner, carburetor and governor.

When filling gas tank, turn off engine, use good clean gasoline, straining through screened funnel or through chamois.

## AIR CLEANER

The air cleaner (right side of tractor, adjacent to battery) removes dust and dirt particles from all the air that passes into the carburetor. This excludes abrasives which would normally cause excessive wear on cylinders, pistons, rings and valves.

Diagram shows how air loses larger dirt particles in top screen, deposits more in bottom oil bath, and drops remaining particles in the filtering elements in the body of the air cleaner which, due to the washing action, causes foreign matter to settle in the bowl at the bottom of the filter.

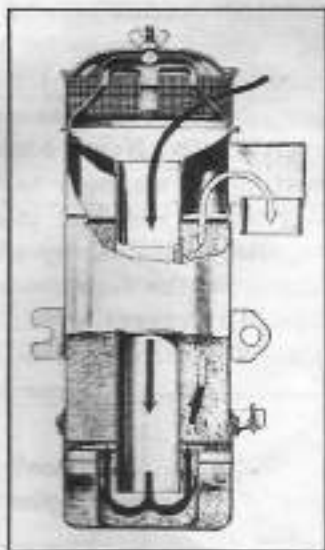

## CARE OF THE AIR CLEANER

The air-cleaner bowl should be cleaned and re-filled daily with clean oil of the same viscosity as that used in the engine.

Under very dusty and dirty conditions, however, it may be advisable to clean *vice* each day.

Remove top inlet screen daily and wash in gasoline. Never oil this screen. If main filtering ele-

ment is plugged with lint or other foreign matter which cannot be washed out, install a new air cleaner, as any restriction of air flow will cause a choking action, resulting in excessive fuel consumption and loss of engine power.

Inspect cleaner periodically for breaks in center tube and outside case to insure good cleaning action. The tube and hose between air cleaner and carburetor should be regularly checked for air leakage. Any leakage or by-passing of air cleaner may result in serious damage to the engine.

## FUEL FILTER AND SEDIMENT BOWL

The fuel filter and sediment bowl assembly, which traps sediment and foreign matter in the gasoline, is screwed into the bottom of the left side of the fuel tank. It serves as a shut-off valve, stopping the gasoline flow to the carburetor, and controls both main and reserve fuel supplies. (Note: Valve has a lefthand thread.) Turn fully to right (clockwise) to shut off fuel supply. Turn fully to the left (counterclockwise) to operate main fuel supply through the standpipe which extends approximately one inch above tank bottom. The reserve supply contains approximately one gallon which is released by turning shut-off valve two complete turns to right from full open position, thus opening the reserve fuel line which is flush with the bottom of the tank.



Sediment bowl with reserve fuel control. Remove bowl and filter and clean every week.

# CARBURETOR

The balanced updraft type carburetor is fully sealed against entrance of dust and dirt. An excess fuel drain (a porous, fused metal-substance in the bottom) permits escape of excess fuel yet prohibits entry of dust or other foreign matter.

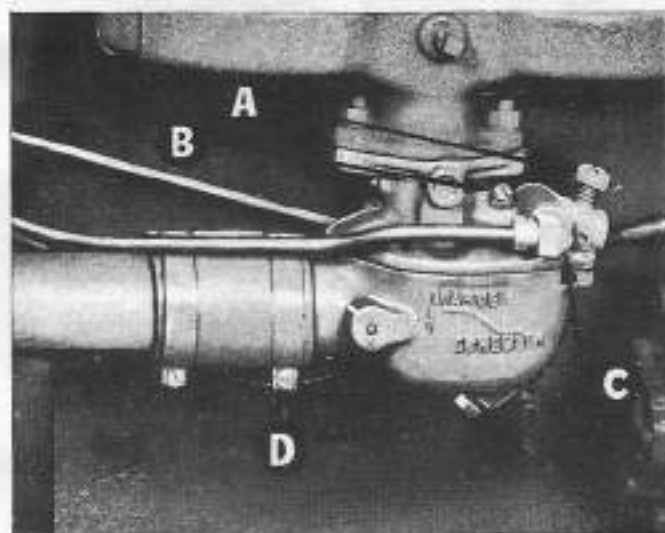

(A) Main jet, (B) idling adjustment, (C) fuel inlet and (D) drain plug are shown above.

At the bottom of the carburetor bowl is a drain plug which permits draining fuel from the carburetor to remove water or dirt.

The carburetor is designed with two settings—an idling system and main fuel system. Each has a separate adjustment.

## MAIN JET ADJUSTMENT

1. Adjust only when engine is warm. Adjust main jet by screwing down needle valve to fully closed position, then backing off one

full turn for approximate setting. Final adjustment should be made so that the engine runs smoothly and according to the load. Too lean a mixture reduces power, overheats engine and may burn valves. Too rich a mixture wastes fuel, causes uneven operation.

**FIELD TEST** With tractor pulling under normal load at approximately one-half throttle, fully open throttle. If engine coughs or stalls, open main jet  $\frac{1}{8}$  turn and repeat test. Continue until engine responds immediately to increased acceleration and runs smoothly and evenly. (Under certain conditions it may be necessary to open main jet  $1\frac{3}{8}$  turns to obtain maximum power.)

## IDLING ADJUSTMENT

2. The idle adjustment should be set at approximately  $\frac{1}{8}$  of a turn open. Accurate setting may be obtained by using a vacuum gauge and adjusting for maximum vacuum. (Adjust only when engine is warm.) An adjusting screw on the throttle shaft arm regulates minimum idling speed.

**CLEANING CARBURETOR** The carburetor should be cleaned seasonally. Remove carburetor from manifold, *take out main adjusting screw*, and disassemble. Always disassemble and clean each part individually. Never blow out carburetor by connecting an air hose to the fuel jet. The elbow strainer at the fuel inlet connection should be regularly cleaned by simply removing the gas line from the carburetor and unscrewing the elbow. To prevent wrench from collapsing elbow, place a  $\frac{1}{4}$ -inch fuel-line nut in elbow fitting when removing or replacing.

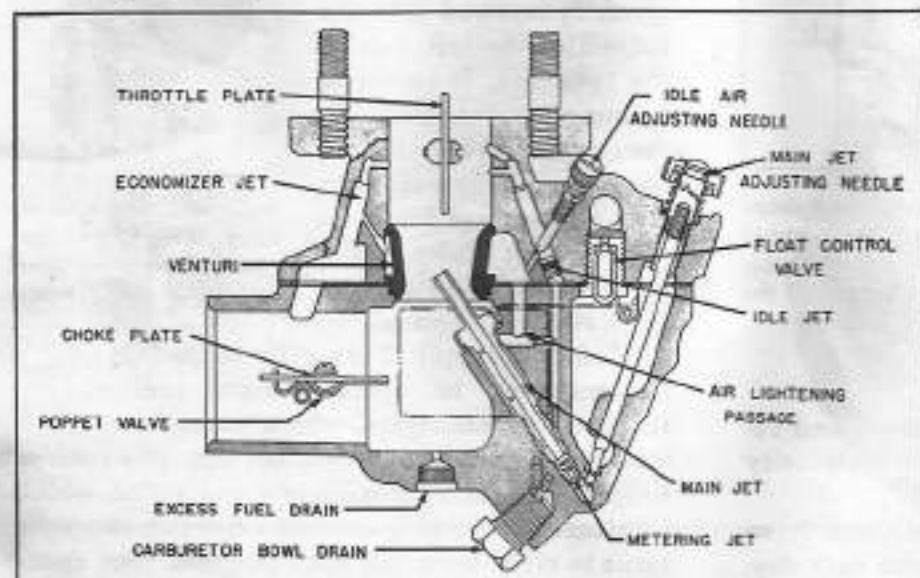

Various parts and adjustments of the carburetor are shown in this photo-diagram. (See "How to adjust carburetor".) Never remove or probe the excess fuel drain plug.

**"Don't refuel when engine's running or very hot!"**



# GOVERNOR

The flyweight type governor has 4 evenly-spaced, die-cast weights, and is attached to the front side of the camshaft gear. It is completely enclosed by the timing gear housing except the control linkage (see illustration). It permits selection of required speed by hand throttle from 400 to 2200 r.p.m., and maintains selected speed between 1200 and 2200 r.p.m. even though the load may vary.

**HOW IT OPERATES** Opening the hand throttle increases the governor spring tension. This causes the governor linkage to overcome force of the flyweights, opening the carburetor throttle plate and increasing the engine speed. Such speed increases give greater force to the governor's flyweights, which begin to overcome the spring tension and gradually close the carburetor throttle plate. A balance is reached between the action of the flyweights and the spring tension which is maintained until either the load or position of the hand throttle is changed.

**Note:** When the hand throttle is set for a certain speed and the load increases, the tractor speed tends to decrease. This reduces the force of the governor flyweights, and the spring tension opens the throttle plate to compensate for the increased load. Exactly the opposite occurs if the load is decreased.

**SERVICING THE GOVERNOR** The governor is lubricated by engine oil forced through bleeder holes from the front camshaft bearing. It requires no special lubrication.

The governor must have perfectly free movement at all locations. Any slight binding will result in erratic action.

To adjust the governor (see illustration):

1. Warm up engine.
2. Set main carburetor jet from 1 to  $1\frac{3}{8}$  turns open.
3. Set idling jet to  $\frac{3}{4}$  of a turn open.
4. Disconnect throttle rod.
5. With throttle lever against idling stop, adjust idling screw to speed of 400-500 r.p.m.
6. Shut off engine.
7. Open hand throttle to create tension on governor spring.
8. Adjust throttle rod length until carburetor throttle lever is  $\frac{1}{32}$ -inch off full stop.
9. Disconnect and remove

governor rod from governor spring.

10. Back off bumper spring screw. Check governor lever for free movement. Check carburetor throttle shaft for binding, and re-connect throttle rod. (Pins must fit freely and clevis must not bind against vertical arm.)
11. Set hand throttle at full open position against steering post.
12. Move approximately 65 degrees forward to idling position.
13. Loosen U-bolt and turn on torque rod until spring hook is just touching torque rod. Tighten U-bolt.
14. Check governor spring.

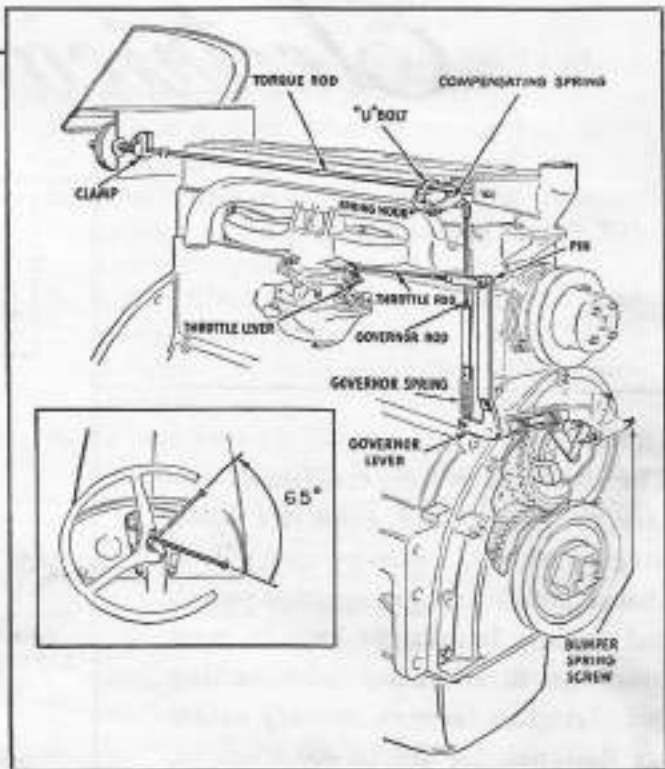

(Open coils indicate a stretched spring and should be replaced.) Spring length is set by opening or closing end loop until spring is neither loose nor in tension when in position on governor rod and against governor lever. With hand throttle at idling position and throttle against idle stop, adjust governor rod length until spring may be connected.

15. Start engine.

16. Check engine speed with hand throttle fully down (see diagram). If not between 2100 and 2200 r.p.m., loosen U-bolt and

turn until correct speed is attained. Then tighten the U-bolt.

17. With engine operating at full throttle, screw in bumper-screw until speed begins to increase. Lock in position with lock nut.

18. If hand throttle tends to creep, adjust friction disc under instrument panel. (This is done by loosening the clamp, compressing the spring and re-tightening the clamp.) If hand throttle still creeps, compensating spring must be shortened by  $\frac{1}{4}$ -inch. (Normal length of spring is 4 inches.)

**Note** 1. Clamp must be located so that it will not strike battery when throttle is operated.

2. For further adjustments of governor, see "Trouble Shooting Section" pages 39 to 42.
3. If governor difficulties continue, see your Ferguson dealer.

TABLE FOR CHECKING ENGINE SPEEDS

Engine r.p.m.	P.T.O. Shaft r.p.m.	Pulley r.p.m.	Rear Wheel r.p.m., with 1 wheel locked—1st gear
400	145	270	10.1
500	181	338	12.7
2000	727	1358	50.8
2100	763	1425	53.3
2200	800	1493	56.

To check: Jack up one rear wheel. Place mark on tire and count revolutions per minute with tractor running in 1st gear.

# Electrical System

The electrical system consists of battery, coil, distributor, generator, spark plugs, starter, voltage regulator, charge indicator light, ignition switch and wiring. It must be kept in good condition to eliminate hard starting and electrical failures. Battery cables are designed for 200 to 400 amperes, but their capacity will be reduced by loose, dirty terminals. Good ground connections are essential between the chassis and battery—starter and generator. The high-tension wires must be kept in good condition to prevent loss of spark. The remaining low-voltage system wiring should be regularly inspected and connections kept clean and secure. Chafed insulation may cause a short.

Many owners will wish to add the Ferguson Lighting Kit for night work as well as other electrical equipment. Description of these and other extra equipment will be found in the Accessories Section, page 37.

**BATTERY** 13-plate, 6-volt. Capacity: 80-ampere hours. Cold weather reduces battery efficiency by slowing up electrochemical action. A fully charged battery with 100% cranking power at 80° F. will drop to 40% cranking power at 0° F. (engine requires 2½ times more cranking effort at 0° than at 80°).

Check battery as follows:

1. **Cable corrosion.** Keep cleaned and greased.
2. **Cracked or broken cases.** May allow escape of solution.
3. **Broken sealing compound.**
4. **Broken or cracked terminal posts.**

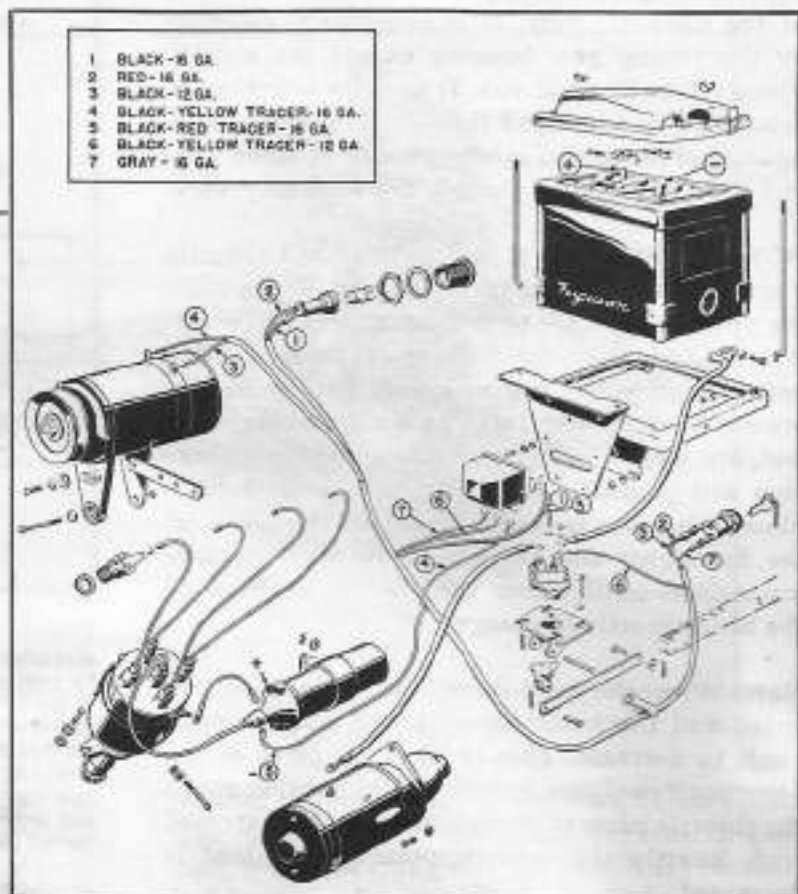

Wiring diagram of Ferguson Electrical System

5. **Freezing,** due to partially discharged condition.
6. **Poor terminal condition.** Keep clean with ammonia or baking soda.
7. **Looseness,** caused by vibration and heavy jars. Keep well tightened to prolong battery life.
8. **Water level.** Fill with distilled water to cover plates. Do not overfill.



**DISTRIBUTOR AND MAINTENANCE** The distributor is fully automatic, advancing the timing as engine speed increases. A special seal between the cap and housing makes the unit dustproof.

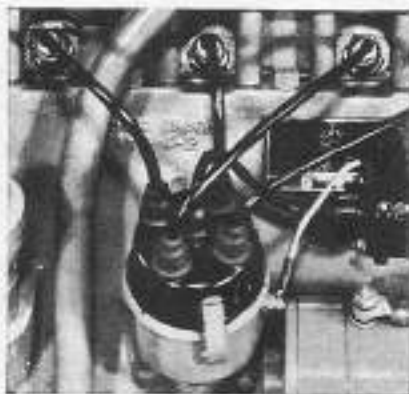

Dustproof wire caps keep dirt and moisture from the distributor.

**Lubrication.** Distributor oil reservoir is filled and sealed at the factory with light engine oil. No further lubrication is necessary for 1500 hours normal operation. When overhauling, refill housing with SAE-20 engine oil, but don't overfill. (Leave small air space above plug hole.) When plug is replaced, seal with sealing compound.

Put a trace of distributor grease on breaker cam every 150 hours. At same interval, put one drop of light engine oil on breaker lever pivot, and a few drops on felt wick under rotor. Avoid excessive lubrication.

**Inspection.** Remove cap and dust seal at regular intervals for examination of contact points, rotor and cap. Check high-tension wiring for frayed or damaged insulation. Be sure there are good connections at cap and plugs (replacing wire if necessary). Cap and rotor should be replaced if former is cracked or if carbonized paths indicate secondary current is leaking to ground over surface.

**Adjusting Distributor.** Distributor points set too close will pit or burn. Points set too wide will give weak spark. Use feeler gauge to check point opening of .020 inch. Keep points clean.

For correct spark delivery, points should open at 7 degrees before top dead center on compression stroke. To set, remove #1 spark plug and crank engine until compression creates pressure on finger held on spark plug hole. Remove timing hole button plug and *crank slowly* until graduated lines on front of flywheel can be seen.

When line indicating 7 degrees before T.D.C. is aligned with groove in timing hole, distributor points should just be open. (See "Valve Adjustment," page 15.) If not, loosen distributor clamp screw and slowly rotate complete distributor



Distributor cap removed to show Bakelite separator which protects points and mechanism from dust and ozone.

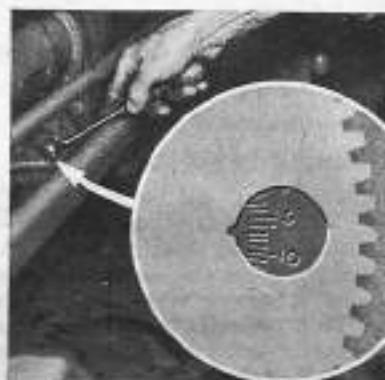

Flywheel timing marks.

Distributor points have just "broken open" in this view of the distributor.



until points just break contact. In case of spark failure, have the condenser coil checked by your dealer.

**IGNITION COIL** Coil is oil-filled and hermetically-sealed to prevent moisture entrance. A Bakelite insulator, with resistance to surface leakage, protects the high-tension terminal. Always keep all leads tightly connected.

**GENERATOR** Six-volt, third-brush type. Driving end rolls on a ball bearing, while commutator end has a bronze bushing. A special drive-end frame and support bracket provide hinge type mounting. A slit in the drive-end frame allows adjustment of the fan belt tension.

**Lubrication.** Put 8 to 10 drops of light engine oil in the two hinge cap oilers every 50 hours. *Caution: Never oil commutator.*

**Inspection.** Remove cover band and inspect commutator and brushes at regular intervals. Clean dirty commutator with No. 00 sandpaper, blowing out accumulated dust. *Caution: Do not use emery paper.* If commutator is rough, out-of-round or has a high mica glaze, have your Ferguson dealer repair it. Replace worn brushes.

**Adjustment.** Generator output may be stepped up by moving third brush in direction of armature rotation (counterclockwise, viewed from rear). To reduce, move third brush in opposite direction. It is advisable to have your Ferguson dealer make this adjustment since charging rate is controlled by the voltage regulator, and generator failure may result if output is set too high.

**Installation warning:** When reinstalling generator or reconnecting leads after they have been disconnected, connect a jumper lead *momentarily* between battery and generator armature terminals *before starting the engine.* This provides a current surge from battery to correctly polarize generator. Do not operate tractor when generator leads are disconnected.

**THE STARTER** The 4-pole, 4-field, 6-volt starter is mounted on the flywheel housing with a special flange. Its armature rotates in oilless bushings in the commutator end and drive housing. The Bendix drive is keyed to the armature shaft . . . auto-



matically engages the cranking pinion with the flywheel ring gear when the cranking motor armature begins to revolve. When the engine starts, the flywheel's overrun effect on the pinion disengages the latter from the flywheel.

**Starter Maintenance.** Ruggedly designed, the starter should give no trouble other than possible

periodic renewal of brushes. In case of failure, disconnect terminal lead and remove two mounting bolts holding unit to drive housing and take entire starting unit to your Ferguson dealer for inspection and overhaul.

**SPARK PLUGS** Recommended are the 18 mm. AC #87 Commercial, Champion #8 Commercial, Autolite BT 8 or their equivalent. Examine frequently for excessive carbon deposits, pitted or burned points and broken porcelain. (Any one of these will decrease engine efficiency.) Regularly clean every 300 hours on a sandblasting machine.

**Inspection and Maintenance.** Regularly check gap-setting with feeler gauge (preferred setting .025 inch). *Note:* In setting gap, bend *outside* electrode to prevent cracking the plug porcelain. Be sure connections are tight and wires in good condition. Before starting tractor, remove any moisture collection in spark plug wells with a dry cloth. Do not overtighten—to do so may distort gap setting.

**VOLTAGE REGULATOR** This sealed unit is built to last the lifetime of your tractor. Never attempt to adjust it. Should regulator appear defective, remove by disconnecting four leads and unscrewing two bolts holding to mounting plate back of instrument panel. Have it checked by your Ferguson dealer.

**STARTER SWITCH** Mounted on transmission housing, just ahead of the steering column. Its contact points are sealed against dirt and moisture . . . are actuated by a plunger projecting inside clutch housing. Plunger is actuated by a rocker connected by a linkage to the reverse shift rail. When transmission shift rail is moved rearward by shift lever, the rocker forces the plunger upward, engaging the switch.

#### Servicing Starter Switch

If switch is to be removed, follow this procedure:

1. Remove battery, ignition and starter cables.
2. Remove four bolts securing switch housing.
3. Raise and tilt switch forward to remove pin. (To prevent switch-to-rail connecting link

from dropping down, fasten with wire or string.)

4. Pull pin and remove switch.
5. To adjust starter switch, loosen anchor nuts and move assembly forward or backward until correct engagement or disengagement is obtained.

# Cooling System

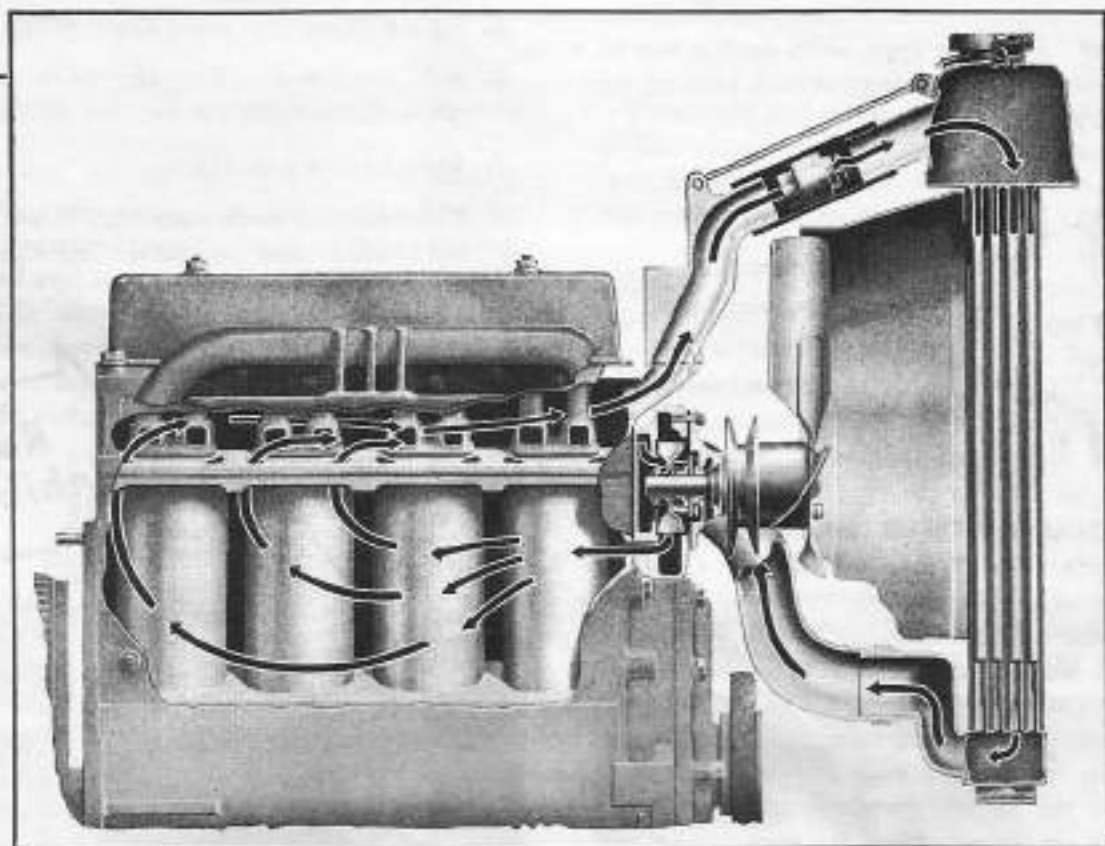

Diagram of engine cooling system.

There are six major parts to the cooling system—radiator, thermostat, pressure-type filler cap, fan, water pump and hose connections. Capacity: 10 quarts (8 Imperial quarts).

**RADIATOR CAP** Pressure-type permits 3 to 4 pounds internal pressure, raising boiling point of coolant 12 to 16 degrees.



*"Don't remove pressure cap when radiator's very hot."*

Remove radiator cap *slowly and carefully* when engine is hot to prevent injury from escaping steam or scalding water. Remove cap when draining radiator.

**RADIATOR FAN** Four-blade, pull-type, mounted

on pump pulley. Turns on a *sealed, pre-lubricated* bearing which needs no additional lubrication.

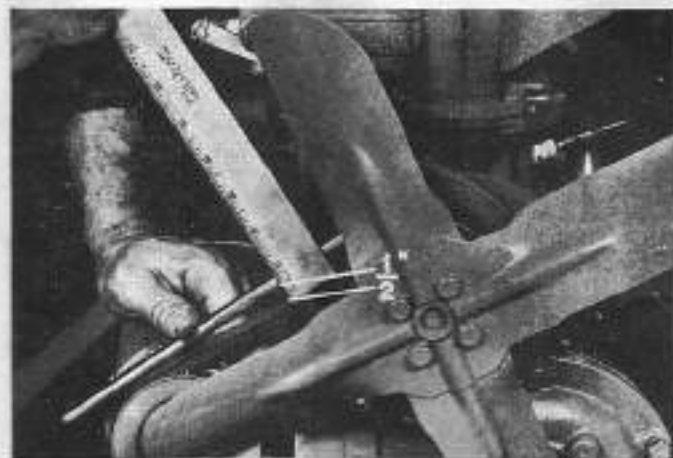

Allow approximately  $\frac{1}{2}$  inch slack in adjusting fan belt.

**THERMOSTAT** Bellows-type, in upper radiator hose. When engine is first started, the thermostat remains closed until coolant temperature reaches approximately 160 degrees. Then bellows expand, opening valve to permit water circulation.

**Note:** Install thermostat with bellows nearest engine.



**WATER PUMP** Impeller-type, with double row of sealed, pre-lubricated bearings which require no lubrication by owner.



*"Inspect radiator hose regularly to prevent leaks."*

**CARE OF COOLING SYSTEM** Soft water or rain water is preferable. Water containing alkalis, acid, salt or other impurities hastens rust and scale formation (also induced when engine is overheated). To prevent corrosive action, use a recommended rust inhibitor.

Clean and flush cooling system twice each year, preferably in fall before addition of antifreeze, and again in the spring (when antifreeze is replaced with clear water). Here are necessary steps in adequate cleaning:

1. Run engine until warm to stir up any accumulation of rust, sludge or sediment.
2. Stop engine, remove filler cap and drain before foreign matter can settle (drain taps are located at bottom of radiator and on right side of cylinder block).
3. Close drain taps and fill system with flushing solution composed of  $\frac{1}{4}$  pound of washing

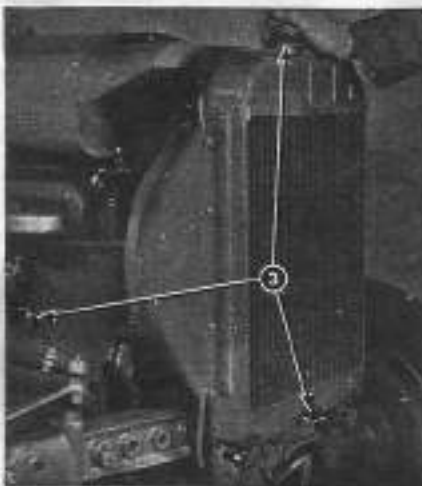

After loosening radiator cap to prevent a vacuum, water is drained from the bottom of the radiator and from the right front side of the engine block.

soda per quart of water (i.e.  $2\frac{1}{2}$  pounds of soda).

4. Replace cap and run engine 30 minutes.
5. Again drain and close drain plugs.
6. Add fresh water. Run engine to permit complete circulation for several minutes.
7. Stop engine and drain.
8. Fill radiator with water or, if cold weather, with water and recommended antifreeze.



Clean clogged radiator fins of dust, dirt or bugs, with an air hose or, in stubborn cases, use a brush.

When straightening bent fins, use care not to damage tubes or break bond between fins and tubes.

**ANTIFREEZE** If using a permanent-type antifreeze, be sure all hose connections are tight or replace with new hose. (Antifreeze will leak where water will not.) Use only recommended antifreeze solutions. These solutions are *not* recommended: calcium chloride, honey, glucose, sugar, kerosene or oils.

**Warning:** Never run engine with cooling system empty. Avoid filling with cold water when engine is very hot. (If necessary, run engine at idling speed and add cold water *very slowly*.)

# Transmission AND Clutch

**TRANSMISSION** The transmission is designed for safe, trouble-free operation and long life. The constant mesh, helical cut gears have sliding shifter collars for quiet operation and effortless shifting. There are three forward working speeds, a road speed and reverse in this four-speed transmission. The sturdy, forged shifter-forks provide positive movement of the shift collars when the shift rails are moved. Detent pins, in notches on the shift rails, control their position, both in neutral and in gear.

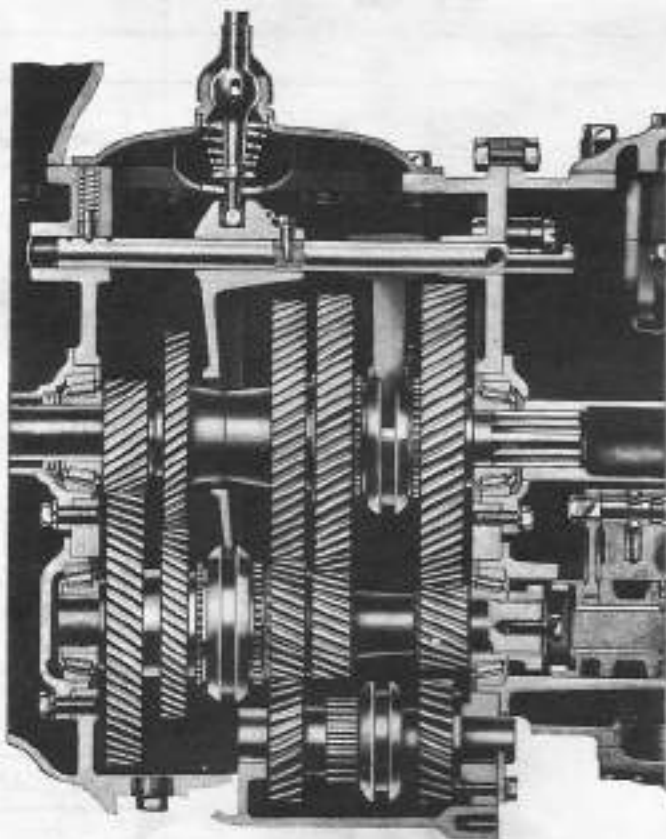

Phantom view of transmission with gear shift lever in neutral position. Photographs on the next page show Reverse, First, Second, Third and Fourth (or Road Speed) positions.



Transmission lubricating level is determined by withdrawing the dipstick which serves transmission, hydraulic system and differential.

Two balls and a pin, arranged in the rear flange of the transmission housing between the shift rails, serve as an added safety device—preventing two gears from being engaged at the same time.

**CLUTCH** The Ferguson single plate, dry disc type clutch requires no adjustment for wear in the clutch itself. It is ruggedly built for smooth, positive engagement.

Adequate clearance between clutch plate release fingers and release bearing is essential for smooth, efficient operation. To adjust, loosen clamp bolt and, with a bar inserted in the hole in



The  $\frac{3}{16}$ -inch free play of the clutch pedal is easily adjusted as shown in this photograph. If radius rod ball becomes loose, take out shims as required.

the end of clutch shaft, turn until a free play of  $\frac{3}{16}$  of an inch is obtained in clutch pedal.

Disengage clutch smoothly and evenly for longer life. Never ride clutch pedal.



**"Never Ride  
the  
Clutch Pedal."**

**TRANSMISSION AND CLUTCH (Cont'd)**

One of the outstanding features of the Ferguson Transmission is the constant mesh, helical cut gears. This more expensive type of construction means longer life, quieter operation and smoother, longer performance.

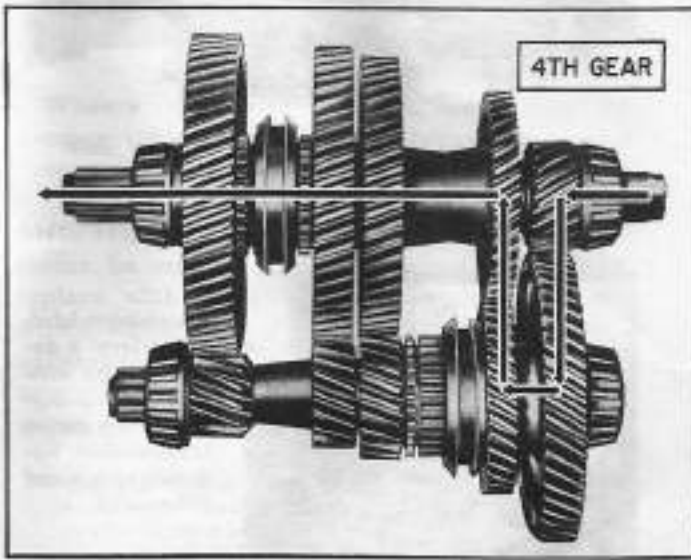
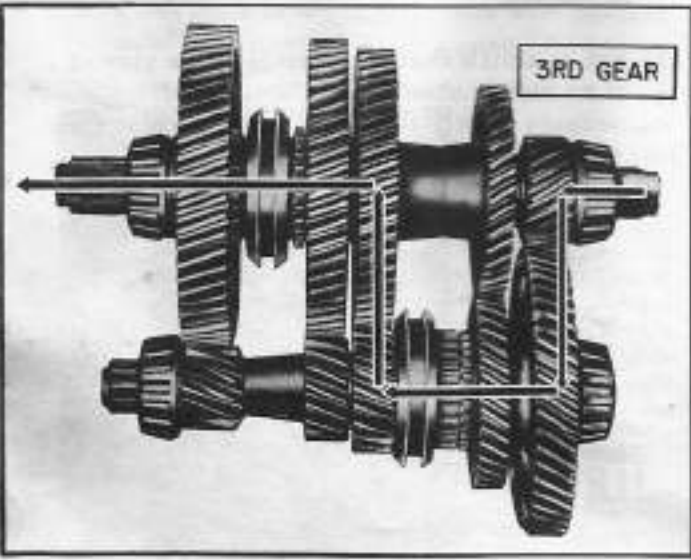
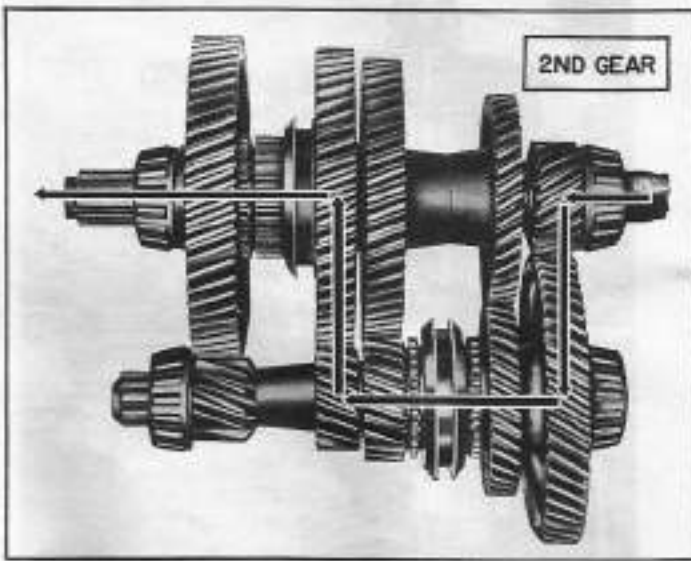
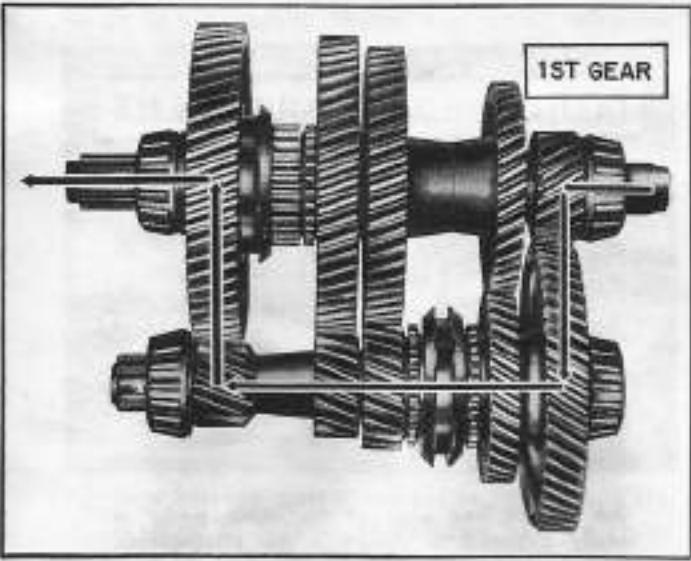
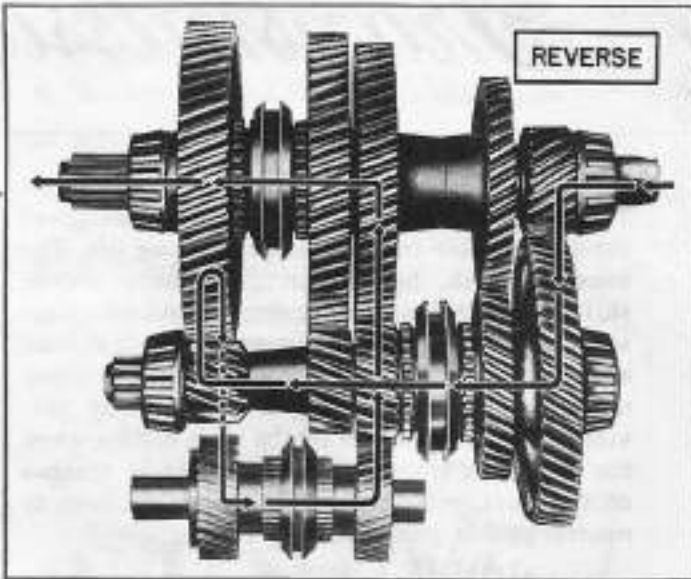

# THE Ferguson System

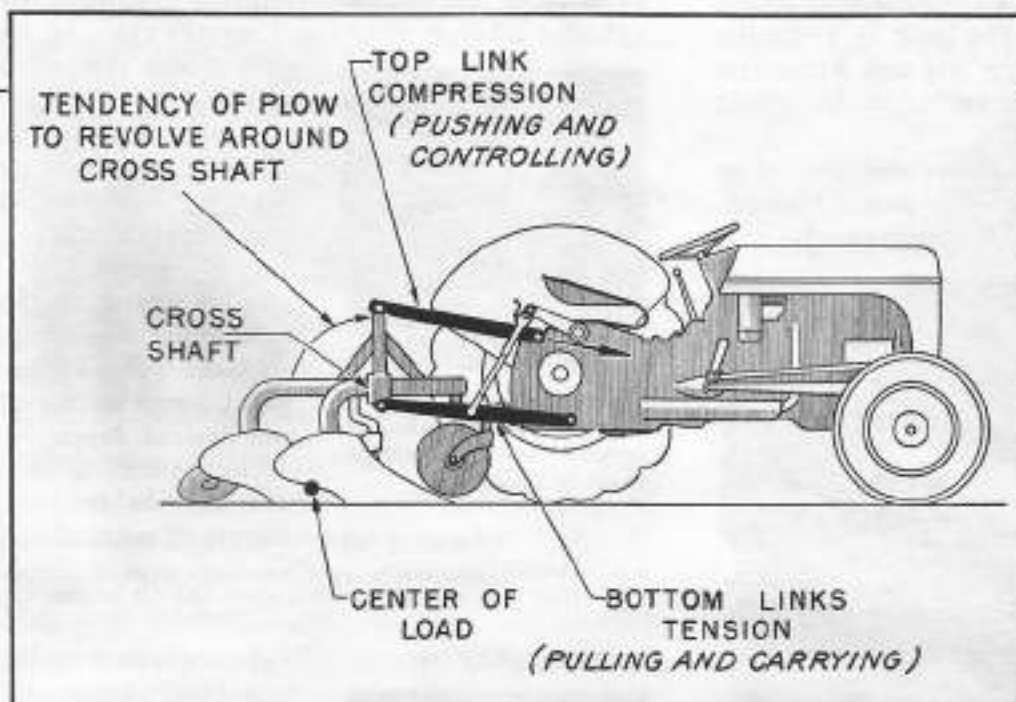

This diagram shows how the linkage applies soil force to the tractor's rear wheels . . . keeps the front end down . . . doesn't require extra weight.

The Ferguson System is a series of linkages which convert *both* tractor and implement into a single, self-propelled unit—giving the operator hydraulic control of the implement from the tractor seat, and continuous automatic control of the implement in the soil.

The Ferguson System provides many distinct advantages. These include:

- ★ Penetration without excess weight.
- ★ Finger Tip Hydraulic control.
- ★ Traction, without excessive built-in or added weight . . . automatically adjusted to the individual job.
- ★ Front end of the tractor kept down on the ground.
- ★ Both tractor and implement automatically protected when obstructions are hit.
- ★ Quick attaching or detaching of all implements, including cultivator.
- ★ Light, easily handled implements that can be backed readily into the machine shed and stored in small space.

★ Great durability combined with light weight throughout, made possible by the principle of the Ferguson System.

★ Faster, easier transport of implements to and from fields due to Ferguson carrying system.

★ Easy backing of implements for working out corners, working in small fields, gardens and truck patches, or odd shape lands.

★ No backbreaking effort required to adjust implements.

★ Implement remains attached to tractor when obstruction is hit—no necessity for dismounting and reattaching implement.

★ Protection against bogging down in soft spots, because tools can be instantly controlled by Finger Tip Lever.

The Ferguson System utilizes *three links* instead of one to transmit the pulling force of the tractor to the drawn implement. Thus, the Ferguson System utilizes a different basic principle of applying and controlling power—with greater safety and efficiency.

## FERGUSON SYSTEM (Cont'd)

The implement is attached to the tractor with two bottom links which PULL, and by a top link which PUSHES FORWARD and DOWNWARD above the rear axle—making tractor and implement a single unit. The built in hydraulic system provides both Finger Tip and Automatic Implement Control and an exclusive Automatic Overload Protection.

The Ferguson Linkage is raised and lowered by a hydraulic pump, driven by the power take-off. The Finger Tip Control Lever manually con-



Left—Finger Tip Control position for carrying implement. Right—Finger Tip Control in position to operate implement at maximum depth.

trols the flow of oil to ram cylinder. The master control spring assembly automatically regulates this flow in operation.

When the implement is in transport position, the hydraulic ram cylinder is full of oil. When control lever is moved forward, oil is released from the cylinder, permitting implement to be lowered by its own weight. When implement reaches desired depth (controlled by Finger Tip Lever position), oil release from the cylinder is

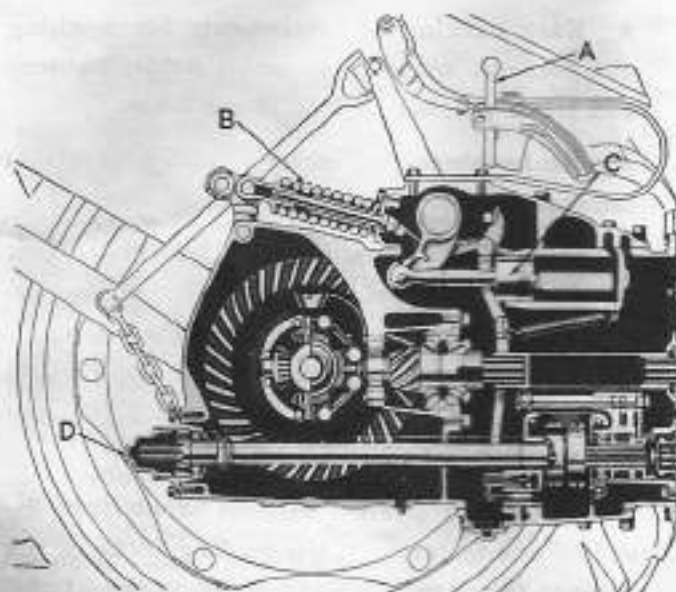

Phantom diagram reveals details of Ferguson System's complete hydraulic system. (A) Finger Tip Control Lever. (B) Master Control Spring. (C) Ram Cylinder and Piston. (D) Power Take-Off.

automatically stopped—implement remaining at the established depth if soil texture remains unchanged. On uneven ground, expansion and compression of master control spring regulates the cylinder oil flow. When soil texture changes, its



Master control spring regulates oil flow of hydraulic system—maintains uniform depth of implement.

weight and resistance requires more or less traction — automatically provided by changing weight and resistance of soil on the moldboards.

Large variations in soil texture require adjustment of Finger Tip Control to maintain desired depth.

The hydraulic system remains inoperative until the power take-off lever is engaged.

**Note:** During extremely cold weather, sluggish operation may be experienced until the oil warms up.

### SAFER OPERATION

Should the implement strike a hidden object, oil pressure within the ram cylinder is automatically released, thereby automatically removing the implement weight from the tractor, reducing the traction on the rear wheels and indirectly reducing the pull on the implement. This automatic safety feature protects operator, tractor and implement.



The leveling crank levels the attached implement.

### ATTACHING IMPLEMENTS

When attaching a Ferguson implement:

1. Back the tractor so that it is centered with the implement.
2. Lower the links by Finger Tip Control.
3. Attach the left bottom link.
4. Attach the right bottom link, using the leveling crank to bring the ball joint in line with the connection.
5. Attach top link to the implement.
6. When seated on the tractor, attach top link to the tractor, moving tractor slightly backward or forward to line up connection for the front pin.

**Note:** The right lift rod is marked by a circular groove which, when level with the top of the fork into which it threads, indicates that both lower links are level.

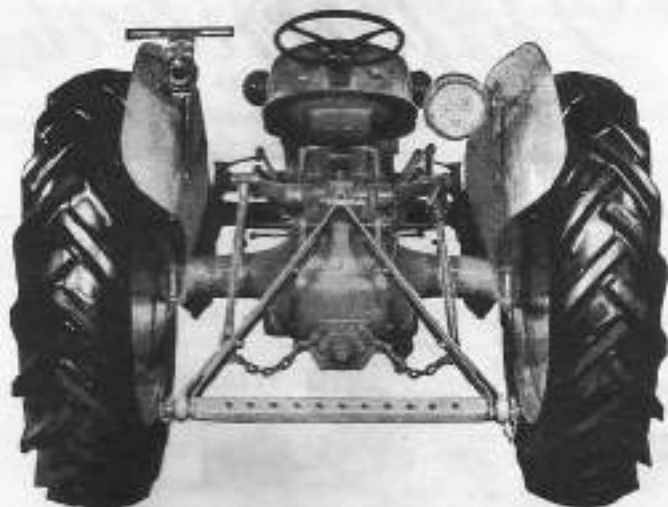

Drawbar stays must be in place before using drawbar.

#### DETACHING IMPLEMENTS

1. Level the implement with leveling crank, then lower on level ground.
2. While seated on the tractor, detach front end of the top link, moving tractor slightly backward or forward, if necessary, to free the pin at its connection.
3. Detach right bottom link, adjusting leveling crank to free strain on ball socket joint.
4. Detach left bottom link.

**Note:** Be careful to put the linch pins in their proper clips on the bottom links to prevent the pins from being torn off.

#### ATTACHING DRAWBAR

1. Lower the linkage.
2. Install the drawbar stay assembly.
3. Lock Finger Tip Control Lever in "down" position with drawbar chain and wedge assembly.
4. Adjust to desired height.

**THE MASTER CONTROL SPRING IS PROPERLY ADJUSTED AT THE FACTORY; MAINTENANCE** Every spring and fall remove the master control spring and grease the threaded portion of the plunger to prevent "freezing" of the yoke threads.

#### TO READJUST SPRING:

1. Attach implement to tractor in transport position (with Finger Tip Control Lever in topmost position).
2. Adjust spring until it can just be rotated freely by hand; then loosen  $\frac{1}{2}$  turn. Quadrant may require adjusting after control spring is adjusted.

**HYDRAULIC LIFT CONTROL QUADRANT** In time, the hydraulic control may require adjustment of the lift control quadrant so that the hydraulic

lift mechanism functions completely. To adjust, follow this procedure:

1. Adjust master control spring per above paragraph.
2. Attach tillage tool to tractor in transport position, with engine running and P.T.O. lever engaged.
3. With a file, knife or pencil, mark the quadrant's "neutral position"—which is  $2\frac{1}{4}$  inches (+ or -  $\frac{1}{8}$  inch) from the topmost position.
4. Loosen four cap screws (found in housing beneath quadrant). These cap screws pass through four slotted holes which permit adjustment of plate.
5. Move quadrant to its rearmost position.
6. Set manual control on mark.
7. Tighten cap screws just snug enough so quadrant can be moved but will not shift position.
8. Move quadrant forward with hammer and punch so implement starts to lower.
9. Tighten cap screws and recheck setting.

**FINGER TIP CONTROL ADJUSTMENT** This lever is held in position by a cork friction disc which, in time, may become worn. If lever slips from

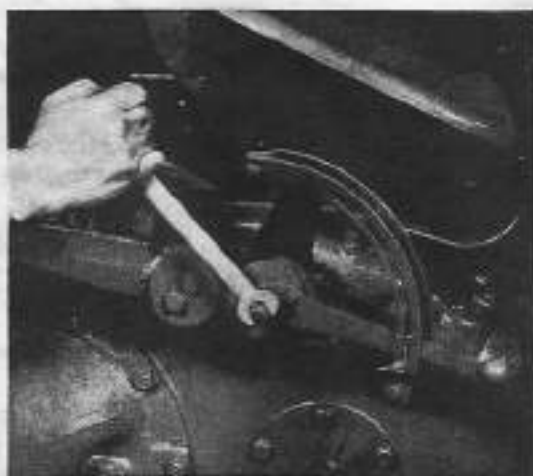

Finger Tip Control Lever is readily accessible for adjustment.

normal position, remove cotter pin from castelated nut at lower end of lever and tighten until lever is firmly seated. Then replace cotter pin.

#### HYDRAULIC CONTROL NOTES:

1. Keep linkage ball joints clean, but **never** lubricate.
2. When using implement requiring operation of power take-off, such as corn-picker, always lock Finger Tip Control Lever in "down" position with wedge and chain.

# Rear Axle AND Differential

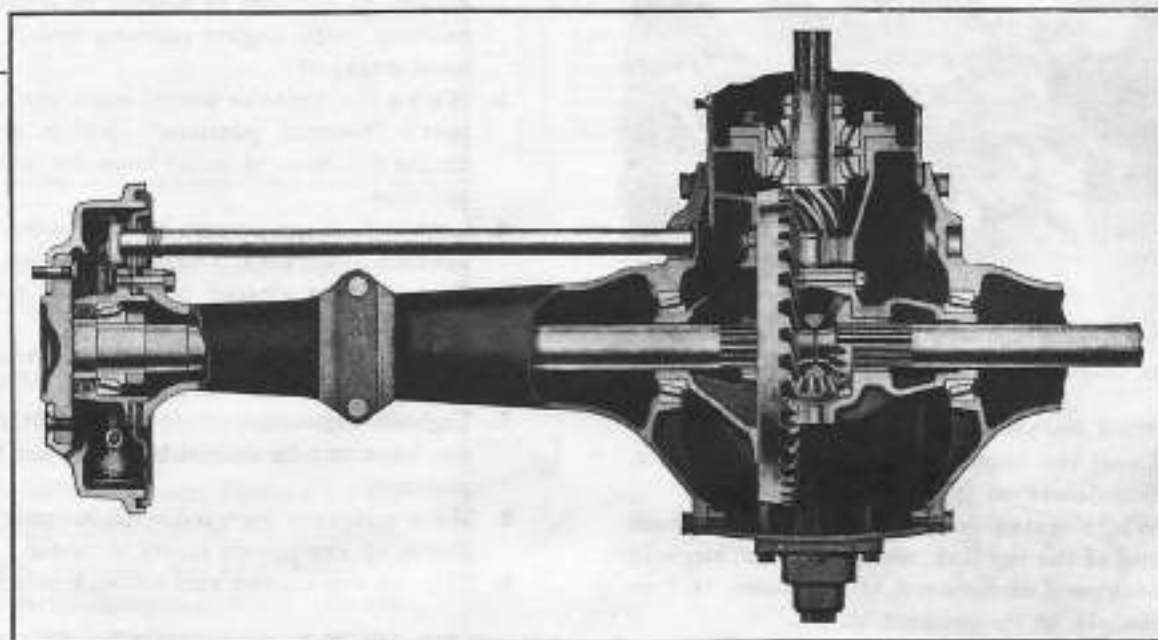

Gear and bearing details of the transmission and rear axle are shown in this phantom view.

The Ferguson rear axle consists of a right and left-hand axle housing and their respective axle shafts, bearing retainers, bearings and oil seals. Both axle housings are attached to the center section, and contain the lower link studs which are the pull-points of the tractor. The inner, splined ends of the forged steel axle shafts are supported in the differential side gear . . . while the outer ends roll on tapered roller bearings, the retainers for which are bolted to the ends of the axle housing.

**DIFFERENTIAL** The differential includes a spiral bevel ring gear and pinion, four differential pinions and two side gears. The entire assembly is suspended in the center housing on two tapered roller bearings, one in each axle housing.

The straddle-mounted drive pinion has two

tapered roller bearings at the front of the pinion. The ring gear is riveted to the differential gear-case, while the side gears and pinion are mounted inside the differential case, backed by copper-coated thrust washers.

Lateral axle movement is prevented by the bearing and its retainer on the wheel side and by the axles butting together in the differential. The rear wheel and brake drum are fastened to the axle shaft flange by eight studs.

**LUBRICATION AND SERVICING** The outer bearing is lubricated by oil thrown out from the differential. It is prevented from going past the bearing by an oil seal in the outer flange of the bearing retainer. To assure leakproof operation, frequently tighten the six nuts holding bearing retainer on end of axle housing.



*"Tighten bearing retainer nuts frequently on both ends of rear axle housing!"*

# Braking System

Your Ferguson Tractor is equipped with internal expanding, fully self-energizing, two shoe-type Bendix brakes. Each wheel may be braked independently by pedals on the corresponding side of the center housing . . . or may be operated together by the single master brake pedal on the right side of the tractor. The brake is 11 inches in diameter . . . the lining is 12½ inches long by 2 inches wide . . . and the total braking area is 100 square inches.

**BRAKE SERVICING** Excessive wear or accumulation of grease may require shoe replacement. To remove, take off wheel and brake drum from axle, detach retracting springs and remove shoes for replacement.

**ADJUSTMENT** Through use and wear, minor adjustments may be necessary. Follow this procedure for adjusting:

1. Jack rear wheels clear of ground;



Adjusting brake shoe action on brake drum of rear wheel.

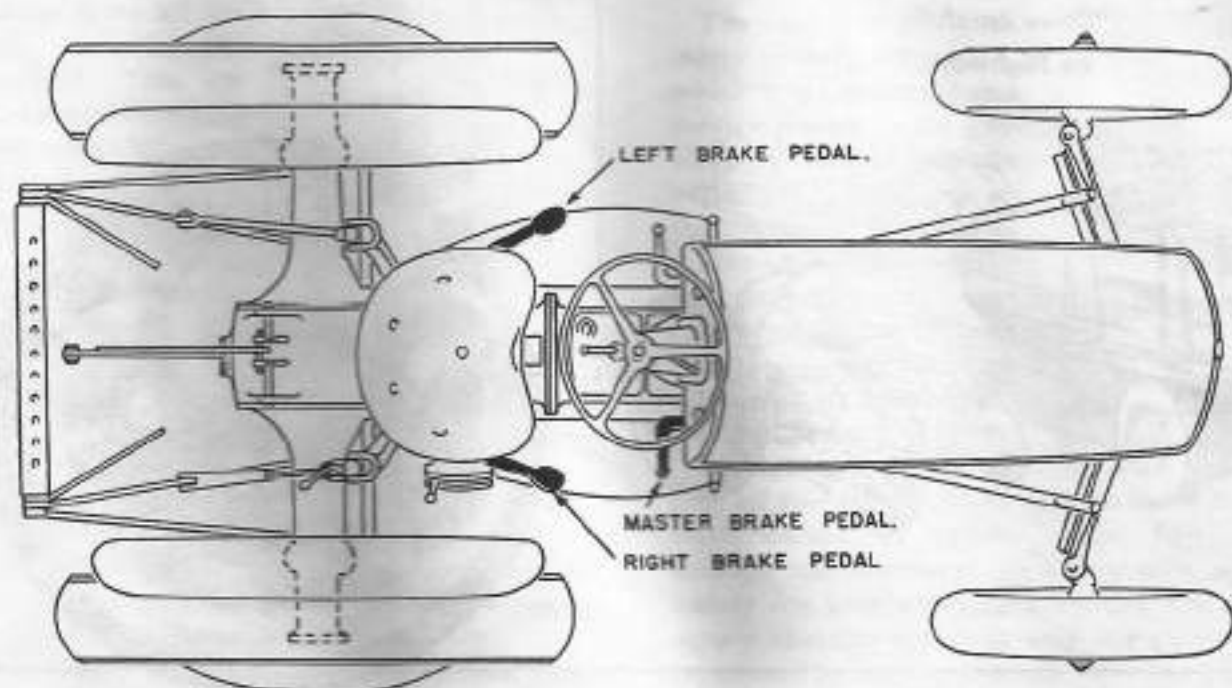

Location of the master brake pedal and the two individual wheel brake pedals is shown in this diagram.



2. Be sure all shafts and pins work freely . . . and, when brakes are off, brake pedals rest against their stops;
3. Remove metal plug on inside of brake drum and turn star-wheel until shoes set so firmly against drum that wheel cannot be turned . . . then back off star-wheel (approximately 12 clicks) until no drag is felt when tractor wheel is turned.

The master brake pedal controlling both rear brakes simultaneously, is located on right side of transmission housing. Its pawl enables the operator to lock it in any position.

4. Test brakes for even balance (when both are operated together) by driving in high gear, disengaging clutch and applying master pedal

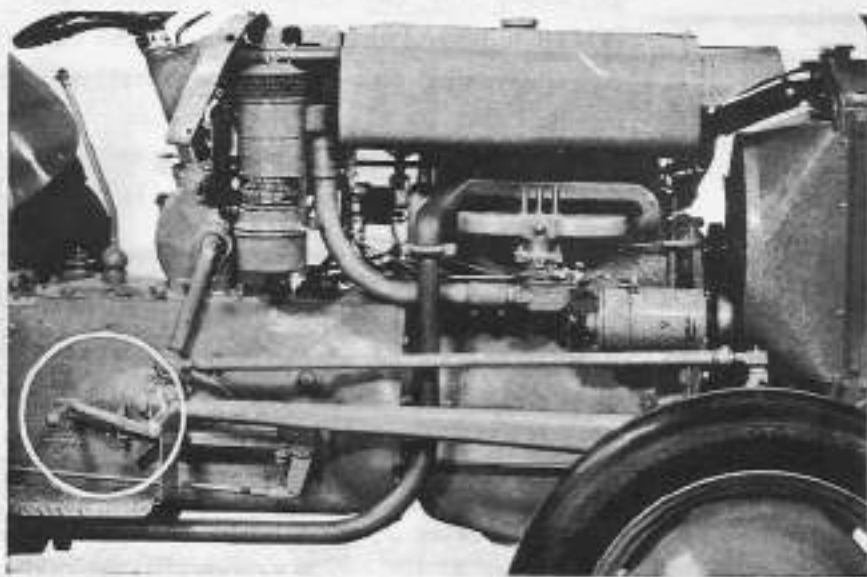

Master brake pedal is shown in this photograph.

until both wheels slide. A similar check may be used on each individual brake.

**"Drive carefully  
on Highways."**

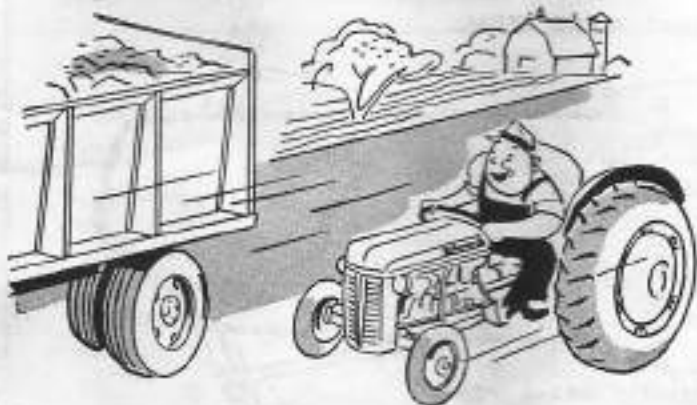

Simple, rugged, long-wearing Bendix internal expanding brakes are used on the Ferguson Tractor.

# THE *Power Take-Off*

The Power Take-Off on your Ferguson Tractor transfers engine power direct to mounted or trailing implements and, when equipped with pulley assembly, to belt-driven equipment such as feed mills, saws, corn shellers, etc.

**The Power Take-Off Lever must be engaged to operate the hydraulic system.** It is part of the inspection plate assembly on left side of center housing. The Power Take-Off shaft projects from center of rear axle housing, being enclosed by a removable cap. At 1500 engine r.p.m., the P.T.O. (power take-off) speed is 545 r.p.m. Diameter of the splined shaft is  $1\frac{1}{8}$  inches.

Power Take-Off Lever in engaged position.

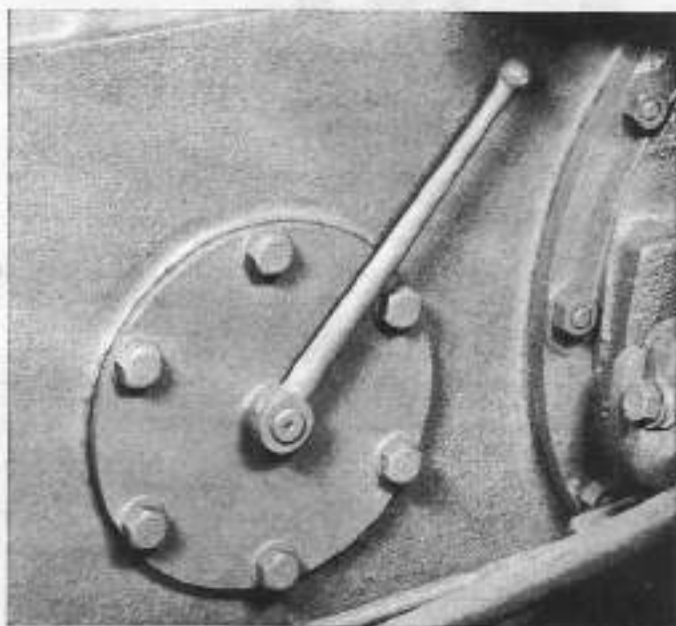

## THE FERGUSON BELT PULLEY

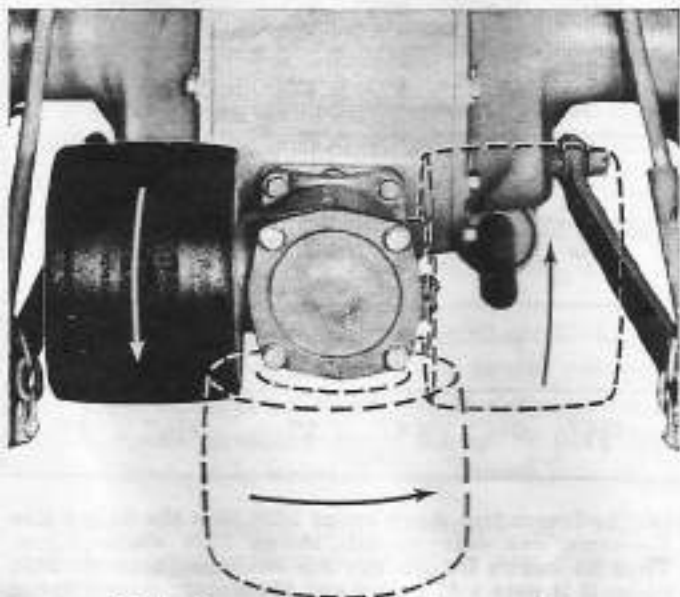

Photo-Diagram shows the three mounting positions of the belt pulley.

The belt pulley for your Ferguson Tractor is a self-contained drive unit. The pulley, available as extra equipment, has a 9-inch diameter and is 6.5 inches wide. Ratio of pulley to power take-off shaft is 1.87 to 1 and the ratio of pulley to engine speeds is 1 to 1.473. The pulley's speed is 1358 r.p.m. at 2000 engine r.p.m.—giving a belt speed of 3200 feet per minute.

To attach belt pulley, remove cover of power take-off shaft as well as check-chain brackets. Pulley then may be mounted in any one of three positions—horizontally on either side to give

correct rotation direction, or vertically with pulley's edge toward ground. (Pulley should never be mounted on top.) Note: Do not force pulley into position with mounting bolts.

Keep the oil reservoir of belt pulley filled to level of filler plug. Capacity  $\frac{3}{4}$  U. S. pint. Use same grade lubricant as in transmission.



**"Never put on or remove belt when pulley's in motion!"**

**NOTE:** To avoid static electricity when using belt and pulley, "ground" tractor to earth.

This table indicates the size pulley necessary to drive any belt-driven machine at the recommended rate. In most instances, there is a choice of at least four pulley sizes, depending on the speed at which you operate your tractor.

Engine r.p.m.	Power Take-Off r.p.m.	Pulley r.p.m.	Belt r.p.m.	R. P. M. OF DRIVEN PULLEY								
				600	800	1000	1400	1800	2200	2600	3000	3400
1400	509	946	2188	14"	10 $\frac{1}{2}$ "	8 $\frac{1}{2}$ "	6"	4 $\frac{1}{2}$ "	4"	3 $\frac{1}{2}$ "		
1500	545	1014	2348	15"	11 $\frac{1}{2}$ "	9"	6 $\frac{1}{2}$ "	5"	4"	3 $\frac{1}{2}$ "		
1600	581	1081	2548	16"	12"	9 $\frac{1}{2}$ "	7"	5 $\frac{1}{2}$ "	4 $\frac{1}{2}$ "	3 $\frac{1}{2}$ "		
1700	618	1149	2708	17"	13"	10 $\frac{1}{2}$ "	7 $\frac{1}{2}$ "	5 $\frac{1}{2}$ "	4 $\frac{1}{2}$ "	4"	3 $\frac{1}{2}$ "	
1800	654	1216	2868	18"	13 $\frac{1}{2}$ "	11"	8"	6"	5"	4"	3 $\frac{1}{2}$ "	
1900	690	1284	3028	19"	14 $\frac{1}{2}$ "	11 $\frac{1}{2}$ "	8"	6 $\frac{1}{2}$ "	5"	4 $\frac{1}{2}$ "	4"	3 $\frac{1}{2}$ "
2000	727	1352	3188	20"	15"	12"	8 $\frac{1}{2}$ "	7"	5 $\frac{1}{2}$ "	4 $\frac{1}{2}$ "	4"	3 $\frac{1}{2}$ "
2100	763	1420	3348	21 $\frac{1}{2}$ "	16"	12 $\frac{1}{2}$ "	9"	7"	6"	5"	4"	3 $\frac{1}{2}$ "
2200	800	1487	3508	22"	16 $\frac{1}{2}$ "	13 $\frac{1}{2}$ "	9 $\frac{1}{2}$ "	7 $\frac{1}{2}$ "	6"	5"	4 $\frac{1}{2}$ "	4"

**Example:** Mr. A. has an ensilage cutter which should be run at 2600 r.p.m. and wishes to determine what size pulley is needed on the ensilage cutter. Looking in the column under 2600, he finds he can use pulleys ranging from 3 $\frac{1}{2}$ " to 5" on same line—in the column on extreme left he finds speed at which tractor engine should be run,

i.e. the fourth line down under 2600 lists the pulley size 4"—same line extreme left shows 1700 engine r.p.m. Thus he knows he can run his ensilage cutter at 2600 r.p.m. if it uses a 4" pulley and his tractor engine speed is set at 1700 r.p.m.

# Tractor Tires... CARE AND INFLATION

Correct inflation for the job is the most important factor in better tractor tire wear. Here are the recommended tire pressures for your Ferguson Tractor: Tires are over-inflated at the factory to prevent damage in shipping. Check pressure as soon as possible.

## RECOMMENDED TIRE PRESSURES

FRONT:	REAR:
4.00-19 ..... 26 lbs.	10-28 ..... 12 lbs.
*6.00-16 (optional) ..... 23 lbs. (4-ply) 36 lbs. (5-ply)	*11-28 (optional) ..... 12 lbs.

\*These wheels and tires are used on Ferguson Wagon and Belle City Corn Picker manufactured after 1948. Available at extra cost.

### UNDER-INFLATION:

1. Damage to cord body resulting in breaks of cord fabric or side wall.
2. Inferior steering and braking control.

3. Tire slippage on rim which may tear off valve stem.
4. Irregular and uneven tread wear.
5. Unnatural tire distortion on hard roads; wiping off tread-bar rubber on highly abrasive or unyielding road surfaces.



Left—note the spongy-appearing buckle or furrow breaks below bead, the result of under-inflation.



Right—inside of the same casing, showing breaks extending through tire carcass.

### OVER-INFLATION:

1. Excessive tread wear,
2. Loss of traction and increased slippage, resulting in increased fuel consumption and loss of speed.
3. Increased packing of soil; rut formation.
4. Casings more susceptible to bruises and impact breaks.

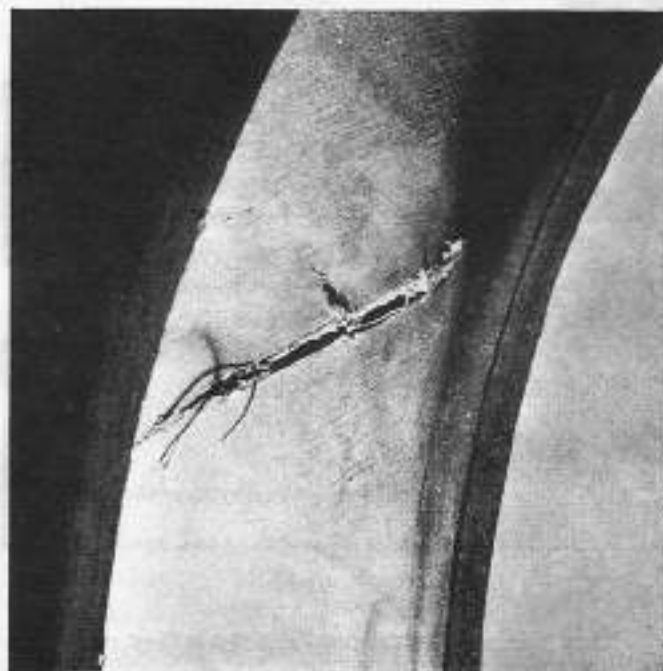

Two types of casing breaks, caused by bruise or impact, that spell trouble. Above—a diagonal break through the side wall. Below—an X-type break. Both ruin the cord structure, will shortly spell tire failure.



### TIRE INSPECTION AND REPAIRS

1. Check tire pressure weekly.
2. Start and stop smoothly for both tire and fuel economy.
3. Avoid excessive slippage which grinds off tread rubber.
4. Remove harmful oil and grease promptly from tires.
5. Wash tires thoroughly with clear water after spraying and dusting operations (especially with Paris Green and Bordeaux mixtures which contain injurious copper).
6. Keep valve caps tight to prevent air pressure escape. Use fingers, not pliers, to protect valve stem threads.
7. Apply brakes slowly and evenly. Abrupt braking causes wasteful tire wear.
8. Allow sufficient clearance between bladed implement edges and tires.
9. Don't speed or overload your tires. Farm tractor tires are designed for slow speeds. If tractor is towed at high speed on the highway, high temperatures develop, weakening rubber and cord structure.
10. Promptly repair side-wall cuts made by sharp stones, glass or metal.

### TIRE REPAIRS

The following suggestions are made for handling the more common tire repairs:

1. *Side or tread cut, exposing fabric.* Thoroughly wash out with gasoline and fill with tread-cut repair gum.
2. *Puncture by large nail or similar object.* Insert rubber plug from inside of casing.
3. *Tire cut by sharp object or cord body broken by striking obstruction.* Temporarily repair by:
  - a. Cleaning inside of casing with gasoline.
  - b. Using fine sandpaper or emery cloth to roughen surface and wiping clean with gasoline.
  - c. Evenly coating area 3 or 4 inches around damage with cold-patching cement. Allow to dry.
  - d. Press firmly in place a cemented cord patch, covering 3 to 4 inches around injury.
  - e. Fill cut or break on outside of casing with tread-cut repair gum.

These are temporary measures only. Have your dealer permanently vulcanize the casing.

# Storing YOUR TRACTOR

If you store your tractor, the following suggestions are made:

1. Thoroughly clean tractor.
2. Remove air cleaner . . . wash filter and inside of cleaner thoroughly with gasoline . . . refill cleaner with new oil and reinstall.
3. Use pressure gun to lubricate all fittings.
4. Drain crankcase completely.
5. Remove oil-filter element and replace with new cartridge.
6. Refill crankcase with recommended grade of oil.
7. Drain and refill transmission with clean oil.
8. Clean and repack front wheel bearings.
9. Check oil level in steering gear.
10. Start engine and run sufficiently to lubricate engine parts.
11. Inspect tractor for worn or damaged parts which later may cause delay—ordering from your Ferguson dealer promptly.
12. Completely drain cooling system, thoroughly washing out and flushing with washing soda and water as detailed on pages 23 and 24.
13. Drain fuel tank—leaving cap off to dry out tank.
14. Remove and clean sediment bulb and replace same.
15. Remove spark plugs and pour two table-spoons of a mixture composed of half gasoline and half light lubricating oil into each cylinder top.
16. Clean spark plugs, setting gaps as necessary.
17. Turn engine over several revolutions, then replace spark plugs. (This will coat cylinder parts with gas-oil mixture.)
18. Stuff end of exhaust pipe with rag.
19. Remove, inspect and condition battery as required, then store in a cool place. (Battery should be kept fully charged. Inspect every two weeks to assure charge is correct.)
20. Store in dry place.
21. Jack up tractor and put on sturdy blocks to remove weight from tires.
22. Cover tractor with tarpaulin for protection. A special storm cover for the engine is available from your dealer.

## FERGUSON-APPROVED

## Accessories

Your Ferguson Tractor comes to you with all necessary equipment for normal operation. For night work and special purposes, certain additional equipment may be desirable. The following special equipment, selected and approved by the manufacturer, is available through your Ferguson Dealer:

- |                              |                        |                                  |
|------------------------------|------------------------|----------------------------------|
| 1. Temperature Indicator Kit | 4. Tractor Jack        | 7. Stabilizer Link Assembly      |
| 2. Belt Pulley               | 5. Storm Cover         | 8. Power Take-Off Conversion Kit |
| 3. Lighting Kit              | 6. Dual Rear Wheel Kit |                                  |

For the above accessories, see your Ferguson Dealer.

# Safety Rules

## THAT WILL PAY YOU DIVIDENDS

1. Bring tractor to complete stop before shifting from a forward gear to reverse, or vice versa.
2. Use master brake pedal on highway or when traveling in high gear.
3. Always stop tractor before dismounting.
4. Never ride on tractor drawbar.
5. Discourage all riders other than operator.
6. Don't smoke or use an oil lantern when refueling or inspecting tank or fuel system.
7. Never wear loose or floppy clothing around tractor's moving parts.
8. Stop engine when refueling, lubricating or inspecting.
9. Keep all nuts and bolts tight—it's safer and good economy.
10. Be sure battery cover is in place when refueling.
11. Never drive too close to edge of creeks or ditches.
12. Always set brakes securely before dismounting . . . or when stopping on a hill or grade.
13. On public roads, watch other traffic . . . use hand signals as required.
14. Before working on electrical system, remove positive ground terminal from battery.
15. Use lifting-straps to remove battery.
16. Don't lay tools, wire or other metal across battery terminals . . . they may cause a serious short.
17. Equip your tractor with lights before driving at night on the highway.
18. Never coast down hill—always keep tractor in gear.
19. Disengage power take-off before dismounting when P.T.O. driven equipment is being used.
20. Lower implements to ground before leaving tractor.
21. Lock Finger Tip Control Lever down when using drawbar. Always disengage power take-off lever when not needed.
22. Watch for holes and obstructions on hillsides and uneven ground to prevent overturning.
23. If rear wheels are frozen to the ground, back tractor to free them. (Otherwise tractor could rotate on its axle.)
24. Take up slack slowly when pulling heavy loads.

**WARNING!**

1. Keep a new tractor on light work for fifty hours.
2. Use third gear for light work only. (See warning on page 46.)
3. Do not attempt to turn sharply while using one brake while traveling at high speed.
4. Do not attempt to pull from the top link connection.
5. Drive slowly in difficult conditions, such as rocky soil, tree roots, etc.
6. Do not carry anything on the implement.
7. Keep all nuts and bolts tight. Check each week.
8. Use an adequate shield to protect the power take-off universal joints.
9. It is dangerous to use the drawbar without the drawbar stays.

**FOLLOW THESE INSTRUCTIONS AND OPERATE YOUR TRACTOR SAFELY!**

# Trouble-Shooting Hints

Minor adjustments on tractor and equipment often can be made by the owner without the necessity of calling a serviceman. The following suggested symptoms and their diagnosis and relief may be helpful in correcting many difficulties.

## APPLY STARTER (with these results):

### Cranks Engine at Normal Speed:

#### Engine starts properly:

- (A) Overheats
- (B) Lacks power
- (C) Excessive fuel consumption
- (D) Knocks
- (E) Excessive oil consumption

#### Engine does Not start:

- Disconnect spark plug cable; hold ¼-inch from engine:
- (F) No spark
- (G) Weak spark
- (H) Good spark

#### Engine misfires:

- (I) Continuous misfiring in one or more cylinders
- (J) Erratic misfiring

### Turns but does not crank Engine:

Refer to (K)

### Does not crank Engine, or cranks Engine Improperly:

Refer to (L)

## (A) ENGINE OVERHEATS

### Possible Cause

1. Radiator water level low
2. Cooling system clogged
3. Radiator core clogged
4. Radiator, water pump or block frozen
5. Radiator fins bent or clogged
  
6. Loose fan belt
7. Water pump leaks
8. Impeller in water pump broken
9. Defective thermostat
10. Oil level low
11. Improper timing
12. Excessive load
13. Too much antifreeze.
14. Heavy carbon deposits in cylinders
15. Brakes set or dragging
16. Carburetor improperly set
17. Collapsed radiator hose

### Possible Remedy

- Add coolant
- Clean thoroughly
- Clean thoroughly
- Thaw out
- Straighten and clean, being careful not to damage tubes
- Tighten belt or replace
- See your Ferguson Dealer
- See your Ferguson Dealer
- Remove and replace
- Add oil
- Check timing—See page 15
- Reduce load or shift to lower gear
- Add water to radiator solution
- See your Ferguson dealer
- Adjust accordingly—See pages 31 and 32
- Adjust carburetor—See page 18
- Change hose



**(B) ENGINE LACKS POWER****Possible Cause**

1. Air cleaner clogged
2. Improper timing
3. Defective or fouled plugs
4. Brakes set or dragging
5. Overheated engine
6. Poor compression, leaky valves,  
worn or stuck rings
7. Badly diluted oil

**Possible Remedy**

- Clean thoroughly—See page 17  
 Check timing—See page 15  
 Change or clean plugs—See page 22  
 Adjust accordingly—See pages 31 and 32  
 See "Engine Overheats"—Page 39

See your Ferguson Dealer  
 Change to new oil

**(C) EXCESSIVE FUEL CONSUMPTION****Possible Cause**

1. Incorrect carburetor adjustment
2. Choke is stuck
3. Dirty air cleaner
4. Poor engine timing
5. Fuel leakage
6. Overheated engine
7. Incorrect lubrication
8. Low-grade fuel
9. Poor traction
10. Overloading
11. Prolonged operation in low gear  
when not necessary
12. Poor spark plugs

**Possible Remedy**

- Adjust carburetor—See page 18  
 Loosen same  
 Clean thoroughly  
 See "Valve Adjustment"—Page 15  
 Check fuel system for leaks  
 See "Engine Overheats"—Page 39  
 See "Lubrication"—Page 7  
 Change to proper grade fuel  
 Tire mounted wrong or badly worn or improperly  
 inflated—See pages 35 and 36  
 See "Warning Against Overloading"—Page 46

Avoid as much as possible  
 Change, clean and inspect—See page 22

**(D) ENGINE KNOCKS****Possible Cause**

1. Heavy carbon deposit in cylinders
2. Improper timing
3. Overheated engine
4. Overloading
5. Low-grade fuel

**Possible Remedy**

- See your Ferguson Dealer  
 Check timing—See page 15  
 See "Engine Overheats"—Page 39  
 See "Warning Against Overloading"—Page 46  
 Change to proper grade

**(E) EXCESSIVE OIL CONSUMPTION****Possible Cause**

1. Rings badly worn or poorly fitted
2. Loose bearings
3. Worn valve guides
4. Oil leakage in gaskets, oil lines,  
or main bearings
5. Wrong grade of oil

**Possible Remedy**

- See your Ferguson Dealer  
 See your Ferguson Dealer  
 See your Ferguson Dealer  
 See your Ferguson Dealer  
 Change to proper grade of good oil

## (F) NO SPARK

### Possible Cause

1. Loose connections at ignition switch
2. Ignition switch not turned on
3. Cracked rotor
4. Dirty breaker points
5. Points not opening
6. Faulty condenser
7. Faulty coil
8. Loose wiring at condenser
9. Distributor is wet

### Possible Remedy

- Check wiring
- Turn on switch
- Replace
- Clean same
- Check timing—See page 15
- Replace same
- Replace same
- Check wiring
- Remove cap and dry thoroughly

## (G) WEAK SPARK

### Possible Cause

1. Condenser terminals are loose
2. Condenser is defective
3. Loose connection on ignition wiring
4. Ignition system wires defective or wet—causing leaks
5. Breaker points burned or pitted
6. Ignition coil defective
7. Distributor cap defective

### Possible Remedy

- Tighten
- Replace same
- Tighten
- Replace same, or dry with clean cloth
- If not serious, file to flat edge; otherwise replace
- Replace same
- Replace same

## (H) GOOD SPARK

### Possible Cause

1. No fuel
2. Faulty spark plugs
3. Engine flooded through excessive use of choke
4. High level of float
5. Empty fuel tank
6. Fuel vent blocked
7. Blocked fuel line
8. Dirt or water in carburetor
9. Poor fuel

### Possible Remedy

- Open fuel valve, or fill tank
- Clean or replace plugs
- Do not choke, but open throttle
- See your Ferguson Dealer
- Fill same
- Clean thoroughly
- Check fuel line and clear same
- Clean carburetor—See page 18
- Use proper grade

## (I) CONTINUOUS MISFIRING OF ONE OR MORE CYLINDERS

### Possible Cause

1. Spark plugs of incorrect type
2. Improper mixture

### Possible Remedy

- Replace with proper type—See page 22
- Spark plug color gives indication of fuel mixture: *If insulator is light brown, mixture and plug are both correct.*
  - a—If insulator is white, mixture is too lean and plug is too hot
  - b—If insulator is blackened or oily, mixture is too rich and plug is too cold

- |   |  |
|---|--|
| 3. Spark plug porcelain cracked   | Replace plug   |
| 4. Spark plug gaps not properly spaced  | Reset gaps—See page 22                                     |
| 5. Spark plug porcelain is dirty, allowing voltage to short circuit from terminal to base of plug | Clean plug thoroughly; if necessary, replace with new plug |
| 6. Leaking spark plug wire  | Replace wire   |
| 7. Short in distributor cap   | Replace same   |
| 8. Low compression in cylinder  | See your Ferguson Dealer                                   |
| 9. Spark plug wire not correctly assembled in distributor plate                                   | Check wiring   |

**(J) ERRATIC MISFIRING**

- | <b>Possible Cause</b>                 | <b>Possible Remedy</b>    |
|---------------------------------------|---------------------------|
| 1. Defective coil                     | Replace same              |
| 2. Defective condenser                | Replace same              |
| 3. Sticking breaker arm               | Lubricate pivot point     |
| 4. Dirty points                       | Clean thoroughly          |
| 5. Weak breaker arm return spring     | See your Ferguson Dealer  |
| 6. Dirty distributor assembly         | Clean thoroughly          |
| 7. Improperly adjusted breaker points | Adjust same—See page 21   |
| 8. Sticky valve action                | See your Ferguson Dealer  |
| 9. Weak valve spring                  | See your Ferguson Dealer  |
| 10. Improperly spaced spark plug gaps | Reset gaps—See page 22    |
| 11. Improperly adjusted valves        | Adjust valves—See page 15 |
| 12. Leakage in intake manifold        | See your Ferguson Dealer  |

**(K) STARTER TURNS BUT DOES NOT CRANK ENGINE**

- | <b>Possible Cause</b>      | <b>Possible Remedy</b> |
|----------------------------|------------------------|
| 1. Bendix drive is dirty   | Clean thoroughly       |
| 2. Bendix spring is broken | Replace spring         |

**(L) STARTER DOES NOT CRANK ENGINE OR CRANKS ENGINE IMPROPERLY**

- | <b>Possible Cause</b>                                 | <b>Possible Remedy</b>           |
|---|----------------------------------|
| 1. Insufficient charge in battery                     | Charge battery                   |
| 2. Loose or disconnected terminal                     | Check wiring                     |
| 3. Corroded battery terminals                         | Clean terminals                  |
| 4. Faulty starter switch                              | Replace same                     |
| 5. Faulty wiring                                      | Check and replace when defective |
| 6. Starter motor brushes and commutator dirty         | Clean thoroughly                 |
| 7. Weak starting motor brush spring                   | See your Ferguson Dealer         |
| 8. Worn out starting motor brushes                    | Replace same with new brushes    |
| 9. Bent starter armature shaft                        | See your Ferguson Dealer         |
| 10. Cracked cylinder head                             | Replace same                     |
| 11. Leaky cylinder head gasket                        | Replace same                     |
| 12. Starter pinion locked in flywheel ring gear       | See your Ferguson Dealer         |
| 13. Engine oil too heavy                              | Use lighter, proper grade of oil |
| 14. Improper adjustment of switch assembly on housing | Adjust                           |

# Specifications

## GENERAL

**Tractor type**  
4-wheel, row-crop tractor, with Ferguson System

**Capacity**  
Two 14-inch plows with the Ferguson System.

**Wheelbase**  
70 inches.

**Over-all length**  
115 inches (front tire rib to end of lower link).

**Over-all width**  
63½ inches at normal tread.  
87½ inches at maximum tread.

**Ground height**  
52 inches.

**Crankcase clearance**  
13¼ inches.

**Front axle clearance**  
21 inches over row.

**Turning circle diameter**  
16 feet (with use of brakes).

**Approximate weight**  
2400 pounds

**Drawbar height**  
18¾ inches (normal).

**Front tread**  
Set by means of adjustable axle and reversible wheel discs, from 48 inches to 80 inches in 4-inch steps.

**Rear tread**  
Adjustable by means of reversible wheel discs and reversible tire rims from 48 inches to 76 inches in 4-inch steps.

## ENGINE

**Type**  
Four-cylinder, four-cycle, internal combustion engine with spark ignition, overhead valves, operated by gasoline.

**Cylinder bore**  
3¾ inches.

**Stroke**  
3¾ inches.

**Piston displacement**  
120 cubic inches.

**Torque**  
Maximum—88 foot-pounds at 1200 r.p.m.

**Compression ratio**  
6.1 to 1.

**Maximum belt horsepower**  
26.50.

**Rated belt horsepower**  
22.53 (85 per cent of maximum).

**Maximum drawbar horsepower**  
21.77.

**Rated drawbar horsepower**  
16.33 (75 per cent of maximum).

**Idle speed**  
400 r.p.m.

**Sleeves**  
Wet-type.

**Pistons**  
Aluminum, cam ground.

**Rings**  
3 compression and 1 oil ring.

**Rod bearings**  
Replaceable-type liners.

**Main bearings**  
Replaceable-type liners.

**Crankshaft**  
Of drop-forged steel, both statically and dynamically balanced within ¼ inch-ounces.

**Compression pressure at cranking speed**  
102-112.

**Oil filter**  
Replaceable cartridge-type of large capacity, located in engine sump.

**Valves**  
Overhead, high lift-type.

**Valve clearance**  
.014 inches when cold (both intake and exhaust).

**Lubrication**  
Pressure-type by gear pump to crankshaft, front and rear cam shaft, connecting rod bearings and overhead valve. Also pressure to governor and timing gears.

**Crankcase capacity**  
6 U. S. quarts (5 Imperial quarts).

**Governor**  
Variable-speed, mechanically-operated, centrifugal-type, fully-enclosed. Regulation obtained from 1200 to 2200 r.p.m.

**Clutch**  
Single, dry plate-type, 9-inch diameter.

**COOLING SYSTEM**

- Radiator*  
Tube and fin-type.
- Capacity*  
10 U. S. quarts (8 Imperial quarts).
- Pump*  
Centrifugal-type, with pre-lubricated bearings.
- Automatic thermostatic control*  
Starts opening at 157° to 162° F.  
Fully opened at 185° F.
- Fan*  
Four-blade, pull-type.

**IGNITION SYSTEM**

- Type*  
Battery.
- Distributor*  
Delco-Remy.
- Firing Order*  
1 - 3 - 4 - 2.
- Distributor drive*  
Gear from cam shaft.
- Spark Advance*  
Automatic 24°.
- Initial timing*  
7° before TDC.
- Maximum Advance*  
2000 r.p.m. 31° before TDC.
- Point gap*  
.020 inches.
- Spark plugs*  
Four 18 mm. AC number 87 commercial, Auto Lite BT8, Champion #8 commercial or their equivalent.

- Spark plug gap*  
.025 inches.
- Coil*  
6-volt, Delco-Remy.
- Battery*  
Ferguson.
- Battery*  
6-volt, 13-plate, lead-acid-type.
- Battery capacity*  
80-ampere hour.
- Generator*  
Delco-Remy.
- Type*  
6-volt, shunt-wound 3-brush, adjustable 3rd brush.
- Output maximum cold*  
15-17 amperes controlled by voltage regulator.
- Voltage regulator*  
Non-adjustable Delco-Remy.

**FUEL SYSTEM**

- Type*  
Gravity flow.
- Fuel tank capacity*  
10 U. S. gallons (8.3 Imperial gallons).
- Sediment bulb assembly*  
Equipped to maintain fuel tank reserve.
- Carburetor-type*  
Updraft, plain tube, dustproof.
- Air cleaner-type*  
Oil bath, with removable dust receptacle.

**TRANSMISSION**

- Type*  
Constant mesh helical gears.
- Speeds*  
Four forward and one reverse.

Speeds	Ratio through final drive	10-28 Tire		11-28 Tire	
		1500 r.p.m.	2000 r.p.m.	1500 r.p.m.	2000 r.p.m.
1st	78.57 - 1	2.48	3.32	2.58	3.45
2nd	57.04 - 1	3.42	4.57	3.56	4.76
3rd	41.45 - 1	4.71	6.29	4.90	6.55
4th	19.86 - 1	9.84	13.13	10.24	13.66
Reverse	68.10 - 1	2.87	3.83	2.98	3.99

## FINAL DRIVE

### *Type drive*

Spiral bevel drive with straddle-mounted pinion.

### *Ratio*

6.66 to 1.

### *Differential*

Four pinion-type, mounted on tapered roller bearings.

### *Rear axle*

Drive axle semifloating-type with integral axle and wheel hubs also mounted on tapered roller bearings.

## STEERING

### *Control*

Both front wheels controlled independently.

### *Lubrication*

Self-lubricated, approximately 2 U. S. quarts.

### *Steering wheel size*

18 inches in diameter.

## TIRES AND WHEELS

### *Front*

4.00-19 pneumatic tires on drop center rims. (Air pressure 26 lbs., 6.00-16 tires optional).

### *Rear*

10-28 pneumatic tires on drop center rims. (Air pressure 12 lbs., air pressure 16 lbs. on furrow wheel tire when plowing, 11-28 tires optional).

## BRAKES

### *Type*

Internal expanding, fully self-energizing.

### *Shoes*

11-inch diameter x 2 inches wide (two for each rear wheel).

### *Operation*

Brakes operate independently on rear wheels to facilitate short turning . . . or may be operated together.

## POWER TAKE-OFF

### *Location*

Extends from rear axle housing.

### *Spline*

1½ inches.

### *Speed*

545 r.p.m. at 1500 r.p.m. engine speed.

### *Ratio to engine speed*

1 to 2.75.

## BELT PULLEY (extra equipment)

### *Type*

Self-contained drive.

### *Size*

9-inch diameter, 6.5 inches wide.

### *Pulley speed*

1358 r.p.m. at 2000 engine r.p.m.

### *Belt speed*

3200 feet per minute at 2000 engine r.p.m.

### *Pulley gear ratio to P.T.O. shaft*

1.87 to 1.

### *Lubrication*

Approximately ¾ U. S. pint.

## HYDRAULIC SYSTEM

### *Type*

Ferguson internal.

### *Maximum pressure*

2000 pounds per square inch.

### *Pump*

Ferguson, piston-type.

### *Drive*

Power Take-Off, internal.

### *Capacity*

2.0 U. S. gallons per minute at 1500 r.p.m. engine speed (2.6 gallons per minute at 2000 r.p.m. engine speed).

## CAPACITIES

### *Gasoline tank*

10 U. S. gallons (8.3 Imperial gallons).

### *Cooling system*

10 U. S. quarts (8.3 Imperial quarts).

### *Crankcase*

6 U. S. quarts (5 Imperial quarts).

### *Transmission, differential and Ferguson Hydraulic System.*

6 U. S. gallons (5 Imperial gallons). If auxiliary hydraulic equipment is used requiring more than 1 U. S. gallon, the amount in excess must be added for satisfactory operation. When detaching equipment, drain to "full mark" on dipstick.

### *Steering gear housing*

2 U. S. quarts.

### *Belt pulley*

Approximately ¾ U. S. pint.

### *Oil bath air filter*

As indicated on bowl.

### *Battery*

80-ampere hours.

# WARNING!

## *against Overloading*

The third gear is too fast for use with heavy draft tillage implements, such as plows, middlebusters, tillers, etc. Such implements, which operate underneath the ground and which are liable to catch on obstructions, may be severely damaged if operated at high speeds. This is true because the impact loads increase as the square of the speed; for example, if the speed is doubled, the impact load will be four times as great. To utilize the increased power of the new Ferguson Tractor, it is much better to use a wider implement, when conditions permit, rather than increase the operating speed.

It is also obvious that the hydraulic system cannot respond as quickly to changes in ground contour when the tractor is operated at high ground speeds, such as may be obtained in third gear. Therefore, all primary tillage operations should be done in second gear.

The third gear is meant to be used for *light work only*, such as mowing, raking, field hauling, harrowing (spike tooth), and with implements which operate *above the ground*.

## *a Test of Overloading*

With the tractor in motion set the throttle lever about half-way open. Then quickly flick the throttle fully open. If the tractor speeds up rapidly the engine is not overloaded—if slowly, the engine is overloaded. These remarks apply to *any* tractor. The overloading should be remedied at once to avoid serious damage.

When operating up a steep hill the above test might indicate overloading. This is not harmful as it is compensated for when coming downhill.

It is *continuous* overloading that must be avoided.

SEE YOUR DEALER FOR  
INFORMATION ON

# *The Ferguson System*



## *The Ferguson Line*

OF IMPLEMENTS INCLUDES

- |                         |                     |
|-------------------------|---------------------|
| Moldboard Plows         | Manure Spreaders    |
| Disc Plows              | Manure Loaders      |
| Two-Way Plows           | Corn Pickers        |
| Spike Tooth Harrows     | Corn Planters       |
| Spring Tooth Harrows    | Lister Planters     |
| Single Disc Harrows     | Grain Drills        |
| Tandem Disc Harrows     | Side Delivery Rakes |
| Bush and Bog Harrows    | Rotary Hees         |
| Offset Disc Harrows     | Cordwood Saws       |
| Spring-Tine Cultivators | Rear Cranes         |
| Rigid-Tine Cultivators  | Middlebusters       |
| Lister Cultivators      | Ridgers             |
| Agricultural Mowers     | Stalk Cutters       |
| Heavy-Duty Mowers       | Four-Row Weeders    |
| Disc Terracers          | Four-Wheel Wagons   |
| Blade Terracers         | Soil Scoops         |

Sub Soilers

11/76 — M.P.

