



Original instructions

**Diesel trucks**  
**With SCR (Selective Catalytic Reduction)**

RX70-60  
RX70-70  
RX70-80



7341 7342 7343 7344  
57348011800 EN - 07/2016

first in intralogistics



## Address of manufacturer and contact details ▷

STILL GmbH  
Berzeliusstraße 10  
22113 Hamburg, Germany  
Tel. +49 (0) 40 7339-0  
Fax: +49 (0) 40 7339-1622  
Email: [info@still.de](mailto:info@still.de)  
Website: <http://www.still.de>





## 1 Foreword

<b>Your truck</b> .....	2
General .....	2
Note regarding SCR (Selective Catalytic Reduction) as exhaust gas treatment .....	2
CE labelling .....	3
EC declaration of conformity in accordance with Machinery Directive .....	4
Accessories .....	5
<b>Information about the documentation</b> .....	6
Documentation scope .....	6
Issue date and topicality of the operating instructions .....	7
Copyright and trademark rights .....	7
Explanation of information symbols used .....	7
List of abbreviations .....	8
Definition of directions .....	11
Schematic views .....	11
<b>Environmental considerations</b> .....	13
Packaging .....	13
Disposal of components and batteries .....	13

## 2 Introduction

<b>Using the truck</b> .....	16
Proper usage .....	16
Proper use during towing .....	16
Impermissible use .....	16
Place of use .....	17
Using working platforms .....	18
<b>Residual risk</b> .....	19
Residual dangers, residual risks .....	19
Special risks associated with using the truck and attachments .....	20
Overview of hazards and countermeasures .....	22
Danger to employees .....	25

## 3 Safety

<b>Definition of responsible persons</b> .....	28
Operating company .....	28
Specialist .....	28
Drivers .....	29
<b>Basic principles for safe operation</b> .....	31
Insurance cover on company premises .....	31

Changes and retrofitting	31
Changes to the overhead guard and roof loads	33
Warning regarding non-original parts	33
Damage, defects and misuse of safety systems	34
Tyres	34
Medical equipment	36
Exercise caution when handling gas springs and accumulators	36
Length of the fork arms	37
<b>Safety tests</b>	38
Regular safety inspection of the truck	38
Checking the diesel engine emissions	38
Particle filter	39
Insulation testing	40
<b>Safety regulations for handling consumables</b>	41
Permissible consumables	41
Oils	41
Hydraulic fluid	42
Battery acid	43
Diesel fuel	44
Coolant and cooling fluid	46
Disposal of consumables	46
<b>Emissions</b>	48
<b>4 Overviews</b>	
<b>Overview</b>	54
<b>Overview of the driver's compartment</b>	55
<b>Operating devices and display elements</b>	56
Display and operating unit	56
Operating devices for hydraulic and driving functions	57
Double mini-lever	58
Three-way mini-lever	59
Four-way mini-lever	60
Joystick 4Plus	61
Fingertip	62
Mini console	63
<b>Labelling points</b>	64
Overview	64
Nameplate	66
Production number	67

StVZO (Road Traffic Licensing Regulations) information	67
<b>5 Operation</b>	
<b>Checks and tasks to be carried out prior to commissioning</b>	70
Visual inspections	70
Filling the washer system	72
Checking the condition of the wheels and tyres	72
Checking the cooling fluid level	74
Checking the engine oil level	74
Adjusting the MSG 65/MSG 75 driver's seat	76
Adjusting the armrest	79
Adjusting the steering column	80
Cleaning the dust valve	81
Checking the pre-cleaner	81
Checking the oil tank on the oil bath air filter	82
<b>Commissioning</b>	83
Climbing into and out of the truck	83
Unlocking the emergency off switch	86
Switching on the key switch	86
Access authorisation with PIN code (variant)	89
Operating the signal horn	99
Seat belt	99
Using the driver's cab	102
Starting the engine	103
Checking the brake system for correct function	105
Checking the steering system for correct function	106
Checking the emergency off function	106
Zero adjustment of the load measurement (variant)	107
Checking the vertical lift mast position (variant) for correct function	109
<b>Driving</b>	110
Safety regulations when driving	110
Roadways	112
Setting the drive programme	114
Selecting the drive direction	115
Actuating the drive direction switch, mini-lever version	116
Actuating the vertical rocker switch for the "drive direction", joystick 4Plus version	117
Actuating the drive direction switch, fingertip version	117
Actuating the drive direction switch, mini-console version	118
Starting to drive	118
Starting drive mode, dual-pedal version (variant)	120

Operating the service brake	123
Parking brake	124
Actuating the mechanical parking brake	124
Steering	126
Reducing speed when turning (Curve Speed Control)	127
Reducing speed with a raised load (variant)	128
Automatic shut-off of the internal combustion engine (variant)	128
<b>Lifting</b>	129
Lifting system variants	129
Automatic lift cut out (variant)	129
Lift mast vertical position (variant)	130
Types of lift mast	134
Malfunctions during lifting mode	135
Hydraulic blocking function	136
Lifting system operating devices	137
Controlling the lifting system using a double mini-lever	138
Controlling the lifting system using a triple mini-lever	139
Controlling the lifting system using a quadruple mini-lever	140
Controlling the lifting system using the joystick 4Plus	141
Controlling the lifting system using the fingertip	143
Changing the fork arms	144
Fork extension (variant)	146
Operation with reversible fork arms (variant)	148
<b>Handling loads</b>	150
Safety regulations when handling loads	150
Before taking up load	151
Load measurement (variant)	152
Picking up loads	155
Danger area	156
Transporting pallets	157
Transport of swinging loads	157
Load pick up	158
Transporting loads	162
Setting down loads	163
Driving on ascending and descending slopes	165
Driving on lifts	165
Driving on loading bridges	166
<b>Particle filter system</b>	167
Particle filter - Function	167
Particle filter - Performing parked regeneration	169
Particle filter - Displays	173



<b>Working with attachments</b> .....	175
Fitting attachments .....	175
Releasing the pressure from the hydraulic system .....	177
General instructions for controlling attachments .....	179
Controlling attachments using a double mini-lever .....	181
Controlling attachments using the double mini-lever and the 5th function .....	183
Controlling attachments using a triple mini-lever .....	185
Controlling attachments using the triple mini-lever and the 5th function .....	187
Controlling attachments using a quadruple mini-lever .....	188
Controlling attachments using the quadruple mini-lever and the 5th function .....	190
Controlling attachments via the joystick 4Plus .....	191
Controlling attachments using the joystick 4Plus and the 5th function .....	192
Controlling the attachments with the fingertip .....	193
Controlling attachments with the fingertip and 5th function .....	194
Clamp locking mechanism (variant) .....	196
Taking up a load using attachments .....	200
<b>Operating auxiliary equipment</b> .....	201
Switching the lighting on and off .....	201
Switching the rotating beacon on and off .....	202
Switching the hazard warning system on and off .....	203
Switching the direction indicators on and off .....	203
Switching the double working spotlights on and off .....	205
Operating the windscreen wiper/washer .....	207
FleetManager (variant) .....	207
Accident recorder (variant) .....	208
Cruise control (variant) .....	208
Driver restraint systems (variants) .....	212
<b>Cab operation</b> .....	212
Opening the cab door .....	212
Closing the cab door .....	213
Opening the side windows .....	213
Closing the side windows .....	214
Operating the interior lighting .....	214
Operating the rear window heating .....	215
Radio (variant) .....	216
Heating system (variant) .....	216
Air conditioning (variant) .....	218
Push-up roof window (variant) .....	219
Clipboard (variant) .....	219
<b>Trailer operation</b> .....	220
Towed load .....	220

Coupling pin in the counterweight .....	221
Automatic tow coupling .....	223
Towing trailers .....	231
<b>Operating the display and operating unit .....</b>	<b>232</b>
Displays .....	232
Adjusting the displays .....	233
Symbols in the display .....	233
Setting the date or time .....	238
Resetting the daily kilometres and daily operating hours .....	238
Setting the language .....	239
Soft key button for operating various equipment variants .....	239
Configuring Blue-Q efficiency mode .....	240
<b>Blue-Q efficiency mode .....</b>	<b>242</b>
Functional description .....	242
Effects on additional consumers .....	242
Switching efficiency mode Blue-Q on and off .....	243
<b>Display messages .....</b>	<b>245</b>
Display content .....	245
Error code table .....	246
General messages .....	249
Drive-specific messages .....	258
<b>Operating in special operating situations .....</b>	<b>266</b>
Transport .....	266
Towing .....	268
Crane loading .....	271
Jump-starting .....	274
<b>Procedure in emergencies .....</b>	<b>276</b>
Emergency shutdown .....	276
Procedure if truck tips over .....	277
Emergency hammer .....	278
Emergency lowering .....	278
Releasing the spring-operated brake .....	280
Disconnecting the battery .....	283
<b>Refuelling .....</b>	<b>283</b>
Diesel fuel — Specifications .....	283
Filling up with diesel fuel .....	287
Using the fuel hand pump .....	288
Topping up AdBlue .....	290
<b>Decommissioning .....</b>	<b>291</b>
Parking the truck securely and switching it off .....	291

Wheel chock (variant) .....	292
Shutting down and storing the truck .....	292
Recommissioning after shutdown .....	294
<b>Cleaning</b> .....	295
Cleaning the truck .....	295
Cleaning the electrical system .....	297
Cleaning load chains .....	298
Cleaning the windows .....	298
After washing .....	299

## 6 Maintenance

<b>General maintenance information</b> .....	302
Personnel qualifications .....	302
Information for carrying out maintenance .....	302
Maintenance instructions .....	305
Maintenance - 500 hours/half-yearly .....	305
Maintenance - 1000 hours/annually .....	307
Maintenance - 3000 hours/every two years .....	311
Ordering spare parts and wearing parts .....	311
Quality and quantity of the required operating materials .....	312
Maintenance data table .....	313
<b>Safety regulations for maintenance</b> .....	316
General information .....	316
Working on the hydraulic equipment .....	316
Working on the electrical equipment .....	317
Working on the ignition system .....	317
Safety devices .....	318
Set values .....	318
Lifting and jacking up .....	318
Working at the front of the truck .....	318
<b>Providing access to maintenance points</b> .....	320
Opening the bonnet .....	320
Closing the bonnet .....	321
Removing and attaching the left side cover .....	322
Installing and removing the bottom plate .....	322
Opening and closing the right-hand service flap .....	324
<b>Service work</b> .....	326
Cleaning the radiator and checking for leaks .....	326
Topping up the cooling fluid and checking the coolant concentration .....	327
Draining water from the fuel filter .....	329

Cleaning the pre-cleaner	331
Cleaning the oil tank on the oil bath air filter	331
Replacing the air filter cartridges	332
Lubricating the joints and controls	334
Checking the door latch	334
Maintaining the seat belt	335
Checking the driver's seat	336
Changing the heating system fresh air filter	337
Replacing the recirculated air filter for the heating system	338
Greasing the automatic tow coupling	338
Servicing wheels and tyres	341
Replacing the fuses	343
Checking the hydraulic oil level	343
Checking the hydraulic system for leaks	345
Lubricating the lift mast and roller track	346
<b>7 1000-hour maintenance/annual maintenance</b>	
<b>Other tasks</b>	348
<b>Checking the exhaust gas system</b>	348
<b>Checking the lift cylinders and connections for leaks</b>	348
<b>Checking the fork arms</b>	348
<b>Checking the reversible fork arms</b>	349
<b>8 Technical data</b>	
<b>Dimensions</b>	352
<b>VDI datasheet</b>	353
<b>Ergonomic dimensions</b>	358
<b>Fuse assignment</b>	360

1

---

## Foreword

## Your truck

# Your truck

## General

The truck described in these operating instructions corresponds to the applicable standards and safety regulations.

If the truck is to be operated on public roads, it must conform to the existing national regulations for the country in which it is being used. The driving permit must be obtained from the appropriate office.

The trucks have been fitted with state-of-the-art technology. All that remains is to handle the truck safely and maintain its functionality.

These operating instructions provide the necessary information to do this. Read and observe the information provided before commissioning the truck. This will prevent accidents and ensure that the warranty remains valid.

## Note regarding SCR (Selective Catalytic Reduction) as exhaust gas treatment

This truck uses the Selective Catalytic Reduction (SCR) process of exhaust gas treatment.

To enable the SCR process to be performed, the truck uses AdBlue (32.5% urea solution, in accordance with DIN 70070 / ISO 22241).

It is recommended that the AdBlue tank be refilled with AdBlue every time the diesel fuel is topped up; see the section "Topping up AdBlue".

The applicable European emission requirements (97/68/EC) state that new engines must have an SCR system.

## CE labelling

The manufacturer uses CE labelling to indicate that the truck complies with the standards and regulations valid at the time of marketing. This is confirmed by the issued EC declaration of conformity. The CE labelling is attached to the nameplate.

An independent structural change or addition to the truck can compromise safety, thus invalidating the EC declaration of conformity.

The EC declaration of conformity must be carefully stored and made available to the responsible authorities.

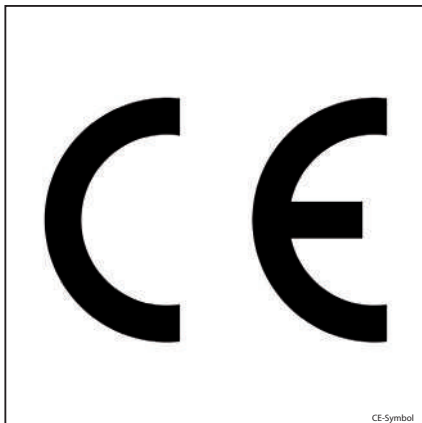

**EC declaration of conformity in accordance with Machinery Directive****Declaration**

STILL GmbH  
Berzeliusstraße 10  
D-22113 Hamburg Germany

We declare that the

Industrial truck	<b>according to these operating instructions</b>
Model	<b>according to these operating instructions</b>

conforms to the latest version of the Machinery Directive 2006/42/EC.

Personnel authorised to compile the technical documents:

See EC compliance declaration

STILL GmbH



**Accessories**

- Key for key switch (two pieces)
- Key for cab (variant)
- Hexagon socket wrench for emergency lowering

## Information about the documentation

# Information about the documentation

## Documentation scope

- Original operating instructions
- Original operating instructions for attachments (variant)
- Spare parts list
- VDMA rules for the proper use of industrial trucks

These operating instructions describe all measures necessary for the safe operation and proper maintenance of your truck in all possible variants available at the time of printing. Special versions to meet customer requirements are documented in separate operating instructions. If you have any questions, please contact your authorised service centre.

Enter the production number and year of manufacturer from the nameplate in the space provided:

### Production number

.....

### Year of manufacture

.....

Please quote the production number during all technical enquiries.

Each truck comes with a set of operating instructions. These instructions must be stored carefully and must be available to the driver and operating company at any time. The storage location is specified in the "Overviews" chapter.

If the operating instructions are lost, the operator must obtain a replacement from the manufacturer immediately.

The operating instructions are included in the spare parts list and can be reordered there as a spare part.

The personnel responsible for operating and maintaining the equipment must be familiar with these operating instructions.

The operating company must ensure that all users have received, read and understood these operating instructions.

 **NOTE**

*Please observe the definition of the following responsible persons: "operating company" and "driver".*

Thank you for reading and complying with these operating instructions. If you have any questions or suggestions for improvements, or if you have found any errors, please contact the authorised service centre.

## Issue date and topicality of the operating instructions

The issue date of these operating instructions can be found on the title page.

STILL is constantly engaged in the further development of trucks. These operating instructions are subject to change, and any claims based on the information and/or illustrations contained in them cannot be asserted.

Please contact your authorised service centre for technical support relating to your truck.

## Copyright and trademark rights

These instructions must not be reproduced, translated or made accessible to third parties—including as excerpts—except with the express written approval of the manufacturer.

## Explanation of information symbols used

 **DANGER**

Indicates procedures that must be strictly adhered to in order to prevent the risk of fatalities.

---

 **WARNING**

Indicates procedures that must be strictly adhered to in order to prevent the risk of injuries.

---

## Information about the documentation

### CAUTION

Indicates procedures that must be strictly adhered to in order to prevent material damage and/or destruction.

### NOTE

*For technical requirements that require special attention.*

### ENVIRONMENT NOTE

*To prevent environmental damage.*

## List of abbreviations

### NOTE

*This list of abbreviations applies to all types of operating instructions. Not all of the abbreviations that are listed here will necessarily appear in these operating instructions.*

Abbreviation	Meaning
°C	Degrees Celsius
°F	Degrees Fahrenheit
A	Amperes
ABE	Display operating unit
ArbSchG	German labour protection law
BetrSichV	German Ordinance on Industrial Safety and Health
BG	Employers' liability insurance association
BGG	Employers' liability insurance association act
BGR	Employers' liability insurance association rule
German Social Accident Insurance	Employers' liability insurance association regulation
Approx.	Approximately
CE	Symbol that confirms conformity with the valid product-specific European directives
CEE	International Commission on the Rules for the Approval of Electrical Equipment
cm	Centimetres

Abbreviation	Meaning
cm <sup>3</sup>	Cubic centimetres
dB	Decibels
DFÜ	Remote data transmission
DIN	German standard
EG	European Community
EN	European standard
FEM	Fédération Européene de la Manutention
F <sub>max</sub>	Maximum power
g	Grams
GAA	Industrial inspectorate
If applicable	If applicable
GPRS	General Packet Radio Service
h/d	Hours per day (time driven each day in hours)
ID no.	ID number
ISO	International standard
kg	Kilograms
kg/m <sup>3</sup>	Kilograms per cubic metre
km/h	Kilometres per hour
km/d	Kilometres per day (kilometres driven each day)
kN	Kilonewtons
kW	Kilowatts
kWh/h	Energy consumption
l	Litres
l/h	Litres per hour
l/min	Litres per minute
LAN	Local area network
LED	Light emitting diode
L <sub>p</sub>	Sound pressure level
L <sub>pAZ</sub>	Continuous sound pressure level in driver's compartment
LSP	Load centre of gravity
o.s.	Or similar
m	Metres

## Information about the documentation

Abbreviation	Meaning
m/s	Metres per second
m/s <sup>2</sup>	Metres per second squared
MAK	Maximum workplace concentration
Max.	Maximum
Min.	Minimum
min	Minutes
rpm	Revolution(s) per minute
mm	Millimetres
N	Newtons
Nm	Newton metres
PIN	Personal identification number
SE	Superelastic
SIT	Snap-in tyre for simplified assembly
StVZO	German Road Traffic Licensing Regulations
t	Tonnes
TRGS	Technical Regulations for Hazardous Substances
a.s.	And similar
V	Volts
VDE	Association for Electrical, Electronic & Information Technologies
VDI	Association of German Engineers
VDMA	German Engineering Federation
W	Watts
WLAN	Wireless local area network
e.g.	For example

## Definition of directions

The directions "forwards" (1), "backwards" (3), "right" (2) and "left" (4) refer to the installation position of the parts as seen from the driver's compartment; the load is to the front.

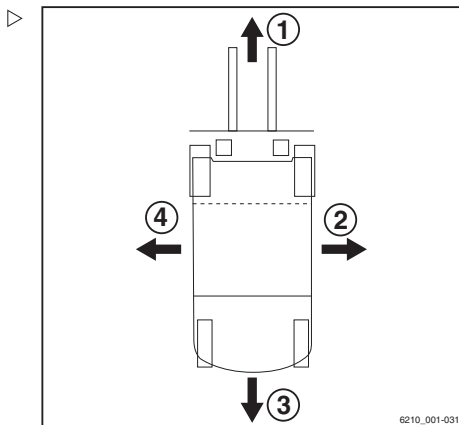

## Schematic views

### View of functions and operations

This documentation explains the (usually sequential) chain of certain functions or operations. Schematic diagrams of a counterbalance truck are used to illustrate these procedures.

#### NOTE

*These schematic diagrams are not representative of the structural state of the documented truck. The diagrams are used solely for the purpose of clarifying procedures.*

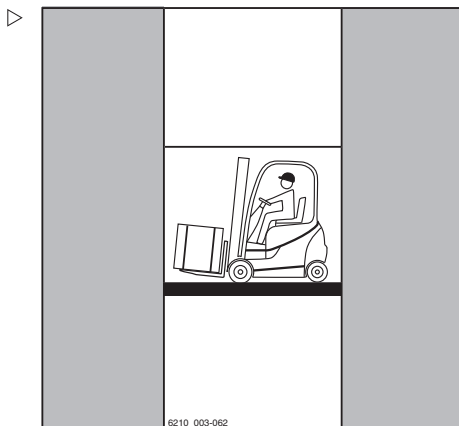

## Information about the documentation

## View of the display operating unit

 NOTE

*Views of operating statuses and values in the display of the display operating unit are examples and partly dependent on the truck equipment. As a result, the displays shown of the actual operating statuses and values can vary. Information that is not relevant for descriptions is not shown.*

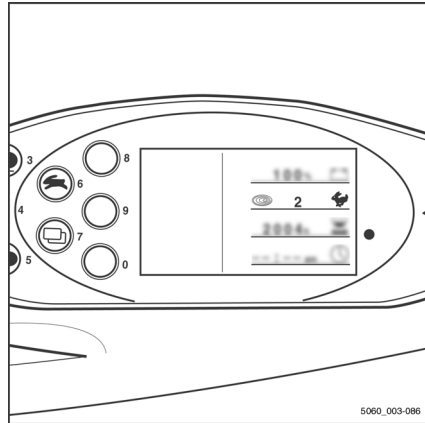



## Environmental considerations

### Packaging

During delivery of the truck, certain parts are packaged to provide protection during transport. This packaging must be removed completely prior to initial start-up.



#### ENVIRONMENT NOTE

*The packaging material must be disposed of properly after delivery of the truck.*

### Disposal of components and batteries

The truck is composed of different materials. If components or batteries need to be replaced and disposed of, they must be:

- disposed of,
- treated or
- recycled in accordance with regional and national regulations.



#### NOTE

*The documentation provided by the battery manufacturer must be observed when disposing of batteries.*



#### ENVIRONMENT NOTE

*We recommend working with a waste management company for disposal purposes.*



2

---

## Introduction

## Using the truck

### Using the truck

#### Proper usage

The truck described in these operating instructions is suitable for lifting, transporting and stacking loads.

The truck may only be used for its proper purpose as set out and described in these operating instructions.

If the truck is to be used for purposes other than those specified in the operating instructions, the approval of the manufacturer and, if applicable, the relevant regulatory authorities must be obtained beforehand to prevent hazards.

The maximum load to be lifted is specified on the capacity rating plate (load diagram) and must not be exceeded; see also the chapter entitled "Before picking up a load".

#### Proper use during towing

This truck is suitable for the occasional towing of trailers and is equipped with a towing device for this purpose. This occasional towing may not exceed 2% of the daily operating time. If the truck is to be used for towing on a more regular basis, the manufacturer should be consulted.

The regulations regarding trailer operation must be observed; see chapter "Trailer operation".

#### Impermissible use

The operating company or driver, and not the manufacturer, is liable for any hazards caused by improper use.

#### NOTE

*Please observe the definition of the following responsible persons: "operating company" and "driver".*

Use for purposes other than those described in these operating instructions is prohibited.

**⚠ DANGER**

**There is a risk of fatal injury from falling off the truck while it is moving!**

- It is prohibited to carry passengers on the truck.

The truck may not be operated in areas where there is a risk of fire, explosion or corrosion, or in areas that are particularly dusty.

Stacking or unstacking is not permissible on inclined surfaces or ramps.

## Place of use

The truck can be used outdoors.

The truck has a closed particle filter system and therefore fulfils the essential prerequisites for use in ventilated halls. The national regulations for the country of use must be observed.

Operation on public roads is only permitted with the "StVZO" (Road Traffic Licensing Regulations) equipment variant.

If the truck is to be operated on public roads, it must conform to the national regulations for the country in which it is being used.

The ground must have an adequate load capacity (concrete, asphalt) and a rough surface. Routes, work areas and aisle widths must conform to the specifications in these operating instructions, see the "Routes" chapter.

Driving on upward and downward gradients is permitted provided the specified data and specifications are observed, see the "Routes" chapter.

The truck is suitable for use in many different countries, ranging from those situated in the Tropics to those in Nordic regions (temperature range: -20°C to +40°C).

This truck is not designed to be operated in cold stores.

The operating company must ensure suitable fire protection for the relevant application in

## Using the truck

the truck's surroundings. Depending on the application, additional fire protection must be provided on the truck. If in doubt, contact the relevant authorities.

### NOTE

*Please note the definition of "operating company" in the sense of responsible persons!*

### DANGER

#### **Risk to health from exhaust gases!**

Exhaust gases from internal combustion engines are harmful to your health. In particular, the soot particles contained in the diesel exhaust gas can cause cancer.

When the internal combustion engine is running, there is a risk of poisoning from the CO, CH and NOx components contained in the exhaust gas.

Modern exhaust gas treatment systems (e.g. catalytic converters, particle filters or comparable systems) can clean exhaust gases in a way that reduces the health hazard and risk of poisoning when operating the truck.

- Observe the national laws and regulations when using trucks with an internal combustion engine in entirely or partially enclosed working areas.
- Always ensure sufficient ventilation.

## Using working platforms

### WARNING

The use of working platforms is regulated by national law. The use of working platforms is only permitted by virtue of the jurisdiction in the country of use.

- Observe national legislation.
- Before using working platforms, consult the national regulatory authorities.

## Residual risk

### Residual dangers, residual risks

Despite careful working and compliance with standards and regulations, the occurrence of other risks when using the truck cannot be entirely excluded.

The truck and all other system components comply with current safety requirements. Nevertheless, even when the truck is used for its proper purpose and all instructions are followed, some residual risk cannot be excluded.

Even beyond the narrow danger areas of the truck itself, a residual risk cannot be excluded. Persons in this area around the truck must exercise a heightened degree of awareness, so that they can react immediately in the event of any malfunction, incident or breakdown etc.

#### **WARNING**

All persons that are in the vicinity of the truck must be instructed regarding these risks that arise through use of the truck.

In addition, we draw attention to the safety regulations in these operating instructions.

The risks can include:

- Escape of consumables due to leakages, rupture of lines and containers etc.
- Risk of accident when driving over difficult ground such as gradients, smooth or irregular surfaces, or with poor visibility etc.
- Falling, tripping etc. when moving on the truck, especially in wet weather, with leaking consumables or on icy surfaces
- Fire and explosion risks due to batteries and electrical voltages
- Human error resulting from failure to observe the safety regulations,
- Unrepaired damage or defective and worn components,
- Insufficient maintenance and testing
- Use of incorrect consumables
- Exceeding test intervals

## Residual risk

The manufacturer is not held responsible for accidents involving the truck caused by the failure of the operating company to comply with these regulations either intentionally or carelessly.

### Stability

The stability of the truck has been tested to the latest technological standards and is guaranteed provided that the truck is used properly and according to its intended purpose. These standards only take into account the dynamic and static tipping forces that can arise during specified use in accordance with the operating rules and intended purpose. However, the danger of exceeding the moment of tilt due to improper use or incorrect operation and losing stability can never be excluded.

The loss of stability can be avoided or minimised by the following actions:

- Always secure the load against slipping, e.g. by lashing.
- Always transport unstable loads in suitable containers.
- Always drive slowly when cornering.
- Drive with the load lowered.
- Even with sideshifts, align the load as centrally as possible with the truck and transport in this position.
- Avoid turning and diagonally driving across slopes or gradients.
- Never have the load facing downhill when travelling on slopes or gradients.
- Pick up only loads of the approved width.
- Always take great care when transporting swinging loads.
- Do not drive over ramp edges or steps.

### Special risks associated with using the truck and attachments

Approval from the manufacturer and attachment manufacturer must be obtained each



time the truck is used in a manner that falls outside the scope of normal use, and in cases where the driver is not certain that he can use the truck correctly and without the risk of accidents.

## Residual risk

## Overview of hazards and counter-measures

### NOTE

*This table is intended to help evaluate the hazards in your facility and applies to all drive types. It does not claim to be complete.*

- Observe the national regulations for the country in which the truck is being used.

Hazard	Measure	Check note √ Complete - Not applicable	Notes
Truck equipment does not comply with local regulations	Test	○	If in doubt, consult competent factory inspectorate or employers' liability insurance association
Lack of skills and qualification of driver	Driver training (sit-on and stand-on)	○	BGG 925 VDI 3313 driver permit
Usage by unauthorised persons	Access with key only for authorised persons	○	
Truck not in a safe condition	Recurrent testing and rectification of defects	○	German Ordinance on Industrial Safety and Health (BetrSichV)
Risk of falling when using working platforms	Compliance with national regulations (different national laws)	○	German Ordinance on Industrial Safety and Health (BetrSichV) and employer's liability insurance associations
Impaired visibility due to load	Resource planning	○	German Ordinance on Industrial Safety and Health (BetrSichV)
Contamination of respiratory air	Assessment of diesel exhaust gases	○	Technical Regulations for Hazardous Substances (TRGS) 554 and the German Ordinance on Industrial Safety and Health (BetrSichV)
	Assessment of LPG exhaust gases	○	German threshold limit values list (MAK-Liste) and the German Ordinance on Industrial Safety and Health (BetrSichV)

Hazard	Measure	Check note ✓ Complete - Not applicable	Notes
Impermissible usage (improper usage)	Issuing of operating instructions	○	German Ordinance on Industrial Safety and Health (BetrSichV) and German Health and labour protection law (ArbSchG)
	Written notice of instruction to driver	○	German Ordinance on Industrial Safety and Health (BetrSichV) and German Health and labour protection law (ArbSchG)
	Note the German Ordinance on Industrial Safety and Health (BetrSichV), the operating instructions and the German Engineering Federation (VDMA) rules	○	
When fuelling			
a) Diesel	Note the German Ordinance on Industrial Safety and Health (BetrSichV), the operating instructions and the German Engineering Federation (VDMA) rules	○	
b) LPG	Note German Social Accident Insurance (DGUV) regulation D34, the operating instructions and the German Engineering Federation (VDMA) rules	○	

## Residual risk

Hazard	Measure	Check note √ Complete - Not applicable	Notes
When charging the traction battery	Note the German Ordinance on Industrial Safety and Health (BetrSichV), the operating instructions and the German Engineering Federation (VDMA) rules	O	Association for Electrical, Electronic and Information Technologies (VDE) regulation 0510: In particular - Ensure adequate ventilation - Insulation value within the permissible range
When using battery chargers	Note the German Ordinance on Industrial Safety and Health (BetrSichV), employers' liability insurance association regulation 104 and the operating instructions	O	German Ordinance on Industrial Safety and Health (BetrSichV) and employers' liability insurance association regulation 104
When parking LPG trucks	Note the German Ordinance on Industrial Safety and Health (BetrSichV), employers' liability insurance association regulation 104 and the operating instructions	O	German Ordinance on Industrial Safety and Health (BetrSichV) and employers' liability insurance association regulation 104
With driverless transport systems			
Roadway quality inadequate	Clean/clear driveways	O	German Ordinance on Industrial Safety and Health (BetrSichV)
Load carrier incorrect/slipped	Reattach load to pallet	O	German Ordinance on Industrial Safety and Health (BetrSichV)
Drive behaviour unpredictable	Employee training	O	German Ordinance on Industrial Safety and Health (BetrSichV)
Driveways blocked	Mark driveways Keep driveways clear	O	German Ordinance on Industrial Safety and Health (BetrSichV)

Hazard	Measure	Check note ✓ Complete - Not applicable	Notes
Driveways intersect	Announce right-of-way rule	○	German Ordinance on Industrial Safety and Health (BetrSichV)
No person detection during depositing and retrieval	Employee training	○	German Ordinance on Industrial Safety and Health (BetrSichV)

## Danger to employees

According to the German Ordinance on Industrial Safety and Health (BetrSichV) and labour protection law (ArbSchG), the operating company must determine and assess hazards during operation, and establish the labour protection measures required for employees (BetrSichVO). The operating company must therefore draw up appropriate operating instructions (§ 6 ArbSchG) and make them available to the driver. A responsible person must be appointed.



### NOTE

*Please observe the definition of the following responsible persons: "operating company" and "driver".*

The construction and equipment of the truck correspond to the Machinery Directive 2006/42/EC and are therefore marked with CE labelling. These elements are therefore not included in the hazard assessment. Attachments possess their own CE labelling and likewise are not included for that reason. The operating company must, however, select the type and equipment of the trucks so as to comply with the local provisions for deployment.

The result must be documented (§ 6 ArbSchG). In the case of truck applications involving similar hazard situations, the results may be summarised. This overview (see chapter "Overview of hazards and countermeasures") provides help on complying with this regulation. The overview specifies the main hazards that are the most frequent cause of accidents in the event of non-compliance. If other major

## Residual risk

operational hazards are involved, they must also be taken into consideration.

The conditions of use for trucks are broadly similar in many plants, so the hazards can be summarised in one overview. Observe the information provided by the relevant employers' liability insurance association on this subject.

3

---

**Safety**

## Definition of responsible persons

# Definition of responsible persons

## Operating company

The operating company is the natural or legal person or group who operates the truck or on whose authority the truck is used.

The operating company must ensure that the truck is only used for its proper purpose and in compliance with the safety regulations set out in these operating instructions.

The operating company must ensure that all users read and understand the safety information.

The operating company is responsible for the scheduling and correct performance of regular safety checks.

We recommend that the national performance specifications are adhered to.

## Specialist

A qualified person is defined as a service engineer or a person who fulfils the following requirements:

- A completed vocational qualification that demonstrably proves their professional expertise. This proof should consist of a vocational qualification or a similar document.
- Professional experience indicating that the qualified person has gained practical experience of industrial trucks over a proven period during their career. During this time, this person has become familiar with a wide range of symptoms that require checks to be carried out, such as based on the results of a hazard assessment or a daily inspection.
- Recent professional involvement in the field of the industrial truck test in question and an appropriate further qualification are essential. The qualified person must have experience of carrying out the test in question or of carrying out similar tests. Moreover, this person must be aware of the latest technological developments.



regarding the industrial truck to be tested and the risk being assessed

## Drivers

This truck may only be driven by suitable persons who are at least 18 years of age, have been trained in driving, have demonstrated their skills in driving and handling loads to the operating company or an authorised representative, and have been specifically instructed to drive the truck. Specific knowledge of the truck to be operated is also required.

The training requirements under §3 of the Health and Safety at Work Act and §9 of the plant safety regulations are deemed to have been satisfied if the driver has been trained in accordance with BGG (General Employers' Liability Insurance Association Act) 925. Observe the national regulations for your country.

### Driver rights, duties and rules of behaviour

The driver must be trained in his rights and duties.

The driver must be granted the required rights.

The driver must wear protective equipment (protection suit, safety footwear, safety helmet, industrial goggles and gloves) that is appropriate for the conditions, the job and the load to be lifted. Solid footwear should be worn to ensure safe driving and braking.

The driver must be familiar with the operating instructions and have access to them at all times.

The driver must:

- have read and understood the operating manual
- have familiarised himself with safe operation of the truck
- be physically and mentally able to drive the truck safely

## Definition of responsible persons

### DANGER

**The use of drugs, alcohol or medications that affect reactions impair the ability to drive the truck!**

Individuals under the influence of the aforementioned substances are not permitted to perform work of any kind on or with the truck.

---

### **Prohibition of use by unauthorised persons**

The driver is responsible for the truck during working hours. He must not allow unauthorised persons to operate the truck.

When leaving the truck, the driver must secure it against unauthorised use, e.g. by pulling out the key.

## Basic principles for safe operation

### Insurance cover on company premises

In many cases, company premises are restricted public traffic areas.



#### NOTE

The business liability insurance should be reviewed to ensure that, in the event of any damage caused in restricted public traffic areas, there is insurance cover for the truck in respect of third parties.

### Changes and retrofitting

If the truck is used for work that is not listed in the guidelines or in these instructions and has to be converted or retrofitted accordingly, you must note that any change to its structural state can affect the handling and stability of the truck, which in turn can lead to accidents.

You should therefore contact your service centre beforehand.

Changes that will adversely affect stability, load capacity and safety systems, among other things, must not be made without the manufacturer's approval.

The truck may only be converted with written approval from the manufacturer. Approval from the responsible authority must be obtained if necessary.

Changes to the brakes, steering, control elements, circumferential view, equipment variants and attachments must also not be made without the prior written approval of the manufacturer.

We warn against installing and using restraint systems not approved by the manufacturer.

## Basic principles for safe operation

### DANGER

#### Risk of injury!

Even when using an approved restraint system, there is some residual risk that the driver might be injured if the truck tips over. This risk of injury can be reduced through the combined use of the restraint system and the seat belt. In addition, the seat belt protects against the consequences of rear-end collisions and falling off a ramp.

- Use the seat belt too.
- 

When carrying out welding work on the truck, it is essential that the battery and all connections to the electronic control cards are disconnected. Contact your service centre.

### DANGER

**If the truck is not equipped with an overhead guard, there is a risk to the driver's life, as he may be struck by a load falling from a lift height of 1800 mm or greater.**

Operation of the forklift truck without an overhead guard is prohibited with a lift height greater than 1800 mm.

- For lift heights of 1800 mm and greater, only use trucks with an overhead guard
- 

In the event that the manufacturer goes into liquidation and the company is not taken over by another legal person, the operating company can make changes to the truck.

To do so, the operating company must fulfil the following prerequisites:

Construction documents, test documents and assembly instructions associated with the change must be archived and remain accessible at all times.

Check that the capacity rating plate, decal information, hazard warnings and the operating instructions are consistent with regard to the changes and modify if necessary.

The change must be designed, checked and implemented by a design office that specialises in industrial trucks in accordance with the standards and directives valid at the time the changes are made.

Decal information with the following data must be permanently affixed to the truck so it is clearly visible:

- Type of change
- Date of change
- Name and address of the company implementing the change.

## Changes to the overhead guard and roof loads

### DANGER

**In the event of the overhead guard failing due to a falling load or the truck tipping over, there are potentially fatal consequences for the driver. There is a risk to life!**

Welding and drilling on the overhead guard changes the material characteristics and the structural design of the overhead guard. Excessive forces caused by falling loads or the truck tipping over may result in buckling of the modified overhead guard and no protection for the driver.

- Do not perform welding on the overhead guard.
- Do not perform drilling on the overhead guard.

### CAUTION

Heavy roof loads damage the overhead guard!

To ensure the stability of the overhead guard at all times, a roof load may only be mounted on the overhead guard if the structural design has been tested and the manufacturer has given approval.

- Seek advice from the authorised service centre for the mounting of roof loads.

## Warning regarding non-original parts

Original parts, attachments and accessories are specially designed for this truck. We specifically draw your attention to the fact that parts, attachments and accessories supplied by other companies have not been tested and approved by STILL.

## Basic principles for safe operation

### **⚠ CAUTION**

Installation and/or use of such products may therefore have a negative impact on the design features of the truck and thus impair active and/or passive driving safety.

We recommend that you obtain approval from the manufacturer and, if necessary, from the relevant regulatory authorities before installing such parts. The manufacturer accepts no liability for any damage caused by the use of non-original parts and accessories without approval.

---

## Damage, defects and misuse of safety systems

Damage or other defects on the truck or attachment must be reported to the supervisor or responsible fleet manager immediately so that they can have the defect rectified.

Trucks and attachments that are not functional or safe to drive may not be used until they have been properly repaired.

Do not remove or deactivate safety systems and switches.

Fixed set values may only be changed with the approval of the manufacturer.

Work on the electrical system (e.g. connecting a radio, additional headlights etc.) is only permitted with the manufacturer's written approval. All electrical system interventions must be documented.

Even if they are removable, roof panels may not be removed, as they are designed to protect against small falling objects.

## Tyres

### **⚠ DANGER**

#### **Risk to stability!**

Failure to observe the following information and instructions can lead to a loss of stability. The truck may tip over, risk of accident!

---

The following factors can lead to a loss of stability and are therefore **prohibited**:

- Different tyres on the same axle, e.g. pneumatic tyres and superelastic tyres
- Tyres not approved by the manufacturer
- Excessive tyre wear
- Tyres of inferior quality
- Changing rim wheel parts
- Combining rim wheel parts from different manufacturers

The following rules must be observed to ensure stability:

- Only use tyres with equal and permitted levels of wear on the same axle
- Only use wheels and tyres of the same type on the same axle, e.g. only superelastic tyres
- Only use wheels and tyres approved by the manufacturer
- Only use high-quality products

Wheels and tyres approved by the manufacturer can be found on the spare parts list. If other wheels or tyres are to be used, authorisation from the manufacturer must be obtained beforehand.

- Contact the authorised service centre on this matter.

When changing wheels or tyres, always ensure that this does not cause the truck to tilt to one side (e.g. always replace right-hand and left-hand wheels at the same time). Changes must only be made following consultation with the manufacturer.

If the type of tyre used on an axle is changed, for example from superelastic tyres to pneumatic tyres, the load diagram must be changed accordingly.

- Contact the authorised service centre on this matter.

## Basic principles for safe operation

### Medical equipment

#### **⚠ WARNING**

Electromagnetic interference may occur on medical devices!

Only use equipment that is sufficiently protected against electromagnetic interference.

Medical equipment, such as pacemakers or hearing aids, may not work properly when the truck is in operation.

- Ask your doctor or the manufacturer of the medical equipment to confirm that the medical equipment is sufficiently protected against electromagnetic interference.

### Exercise caution when handling gas springs and accumulators

#### **⚠ WARNING**

Gas springs are under high pressure. Improper removal results in an elevated risk of injury.

For ease of operation, various functions on the truck can be supported by gas springs. Gas springs are complex components that are subject to high internal pressures (up to 300 bar). They may under no circumstances be opened unless instructed to do so, and may be installed only when not under pressure. If required, the authorised service centre will depressurise the gas spring in accordance with the regulations before removal. Gas springs must be depressurised before recycling.

- Avoid damage, lateral forces, buckling, temperatures over 80°C and heavy contamination.
- Damaged or defective gas springs must be changed immediately.
- Contact the authorised service centre.

#### **⚠ WARNING**

Accumulators are under high pressure. Improper installation of an accumulator results in an elevated risk of injury.

Before starting work on the accumulator it must be depressurised.

- Contact the authorised service centre.



## Length of the fork arms

### DANGER

#### **Risk of accident due to the incorrect selection of fork arms!**

- The fork arms must match the depth of the load.

If the fork arms are too short, the load may fall off the arms after it has been picked up. In addition, be aware that the load centre of gravity may shift as a result of dynamic forces, such as braking. A load that is otherwise resting safely on the fork arms may move forwards and fall.

If the fork arms are too long, they can catch on loading units behind the load that is to be picked up. These other loading units then fall over when the load is raised.

- For help with selecting the correct fork arms, contact the authorised service centre.

## Safety tests

## Safety tests

## Regular safety inspection of the truck ▷

## Safety inspection based on time and extraordinary incidents

The operating company must ensure that the truck is checked by a specialist at least once a year or after particular incidents.

As part of this inspection, a complete check of the technical condition of the truck must be performed with regard to accident safety. In addition, the truck must be thoroughly checked for damage that could potentially have been caused by improper use. A test log must be created. The results from the inspection must be retained until a further two inspections have been carried out.

The inspection date is indicated by an adhesive label on the truck.

- Arrange for the service centre to perform periodic safety inspections on the truck.
- Observe guidelines for checks carried out on the truck in accordance with FEM 4.004.

The operator is responsible for ensuring any defects are remedied without delay.

- Contact your service centre.

**NOTE**

*Observe the national regulations for your country!*

## Checking the diesel engine emissions

- Check the diesel engine emissions annually to TRGS 554.

The exhaust-gas check is to be carried out by a specialist (see ⇒ Chapter "Definition of responsible persons", P. 28) and must be recorded in writing.

- Contact your STILL service centre.



 **NOTE**

*Observe the national regulations for your country!*

## Particle filter

The truck has an SCR (Selective Catalytic Reduction) exhaust gas treatment system as part of its standard equipment. The truck may be operated in entirely or partially enclosed working areas.

 **DANGER**

**Risk to health from exhaust gases! Exhaust gases from internal combustion engines are harmful to your health. In particular, the soot particles contained in the diesel exhaust gas can cause cancer. Letting the combustion engine idle runs a risk of poisoning from the CO, CH and NO<sub>x</sub> components contained in the exhaust gas.**

Modern exhaust gas treatment systems (e.g. catalytic converters, particle filters or comparable systems) can clean exhaust gases in a way that reduces the health hazard and risk of poisoning when operating the truck.

- Observe the national laws and regulations when using trucks with an internal combustion engine in entirely or partially enclosed working areas.
- Always ensure that there is sufficient ventilation available.

 **NOTE**

*Observe the national regulations of the country in which the truck is being used!*

The operating company must ensure that the below requirements are met; see the chapter entitled "Definition of terms used for responsible persons":

- Usage must be reported to the responsible occupational health and safety authorities
- Operating instructions must be displayed in the working areas
- Danger areas must be confined and indicated by appropriate warning and safety signs

## Safety tests

- Employees must be made aware of dangers and protective measures
- The particle filter must be replaced every 6000 operating hours. The exhaust-gas check must be carried out by a competent person (see the chapter entitled "Definition of terms used for responsible persons") and the results must be recorded in writing

### NOTE

*Observe the TRGS 554 regulations and the national regulations of the country in which the truck is being used.*

## Insulation testing

The truck insulation must have sufficient insulation resistance. For this reason, insulation testing in accordance with DIN EN 1175 and DIN 43539, VDE 0117 and VDE 0510 must be conducted at least once every year.

### NOTE

*Contact your service centre to arrange for an insulation test.*

## Measuring the insulation resistance of the electrical system

### NOTE

*Nominal battery voltage < test voltage < 500 V.*

- Ensure that all voltage sources have been disconnected from the circuit to be tested.
- Measure the insulation resistance with a suitable measuring device.

The insulation resistance can be considered sufficient if it measures at least 1000  $\Omega/V$  for nominal battery voltage against ground.

- Contact the authorised service centre.

## Safety regulations for handling consumables

### Permissible consumables

#### DANGER

**Failure to observe the safety regulations relating to consumables may result in a risk of injury, death or damage to the environment.**

- Observe the safety regulations when handling such materials.

---

Refer to the maintenance data table for the permissible substances that are necessary for operation (see ⇒ Chapter "Maintenance data table", P. 6-313).

### Oils



#### DANGER

**Oils are flammable!**

- Follow the statutory regulations.
- Do not allow oils to come into contact with hot engine parts.
- No smoking, fires or naked flames!



#### DANGER

**Oils are toxic!**

- Avoid contact and consumption.
- If vapour or fumes are inhaled, move to fresh air immediately.
- In the event of contact with the eyes, rinse thoroughly (for at least 10 minutes) with water and then consult an eye specialist.
- If swallowed, do not induce vomiting. Seek immediate medical attention.

## Safety regulations for handling consumables



### ⚠ WARNING

Prolonged intensive contact with the skin can result in dryness and irritate the skin!

- Avoid contact and consumption.
- Wear protective gloves.
- After any contact, wash the skin with soap and water, and then apply a skin care product.
- Immediately change soaked clothing and shoes.

### ⚠ WARNING

There is a risk of slipping on spilled oil, particularly when combined with water!

- Spilt oil should be removed immediately with oil-binding agents and disposed of according to the regulations.



### ENVIRONMENT NOTE

*Oil is a water-polluting substance!*

- *Always store oil in containers that comply with the applicable regulations.*
- *Avoid spilling oils.*
- *Spilt oil should be removed immediately with oil-binding agents and disposed of according to the regulations.*
- *Dispose of old oils according to the regulations.*

## Hydraulic fluid



### ⚠ WARNING

These fluids are pressurised during operation of the truck and are hazardous to your health.

- Do not spill the fluids.
- Follow the statutory regulations.
- Do not allow the fluids to come into contact with hot engine parts.

**⚠ WARNING**

These fluids are pressurised during operation of the truck and are hazardous to your health.

- Do not allow the fluids to come into contact with the skin.
- Avoid inhaling spray.
- Penetration of pressurised fluids into the skin is particularly dangerous if these fluids escape at high pressure due to leaks in the hydraulic system. In case of such injury, immediate medical assistance is required.
- To avoid injury, use appropriate personal protective equipment (e.g. protective gloves, industrial goggles, skin protection and skin care products).

**ENVIRONMENT NOTE**

*Hydraulic fluid is a water-polluting substance.*

- *Always store hydraulic fluid in containers that comply with regulations*
- *Avoid spills*
- *Spilt hydraulic fluid should be removed immediately with oil-binding agents and disposed of according to the regulations*
- *Dispose of old hydraulic fluid according to the regulations*

**Battery acid****⚠ WARNING**

Battery acid contains dissolved sulphuric acid. This is toxic.

- Avoid touching or swallowing the battery acid at all costs.
- In case of injury, seek medical advice immediately.

## Safety regulations for handling consumables



### **⚠ WARNING**

Battery acid contains dissolved sulphuric acid. This is corrosive.

- When working with battery acid, always wear a protection suit and eye protection.
  - When working with battery acid, never wear a watch or any jewellery.
  - Do not allow any acid to get onto clothing or skin or into the eyes; if this does happen, rinse immediately with plenty of clean water.
  - In case of injury, seek medical advice immediately.
  - Immediately rinse away spilt battery acid with plenty of water.
  - Follow the statutory regulations.
- 



### **ENVIRONMENT NOTE**

- Dispose of used battery acid in line with the applicable regulations.

## Diesel fuel



### **⚠ WARNING**

Diesel fuel is combustible.

- Observe statutory regulations.
- Do not allow diesel fuel to come into contact with hot engine components.

Do not smoke!

---



**⚠ WARNING**

Diesel fuel is toxic!

- Avoid contact and swallowing.
- If vapour or fumes are inhaled, administer fresh air immediately.
- After contact with the eyes, rinse thoroughly (for at least 10 minutes) with water and then consult an eye specialist.
- If swallowed, do not induce vomiting. Seek immediate medical attention.

**⚠ WARNING**

Prolonged intensive contact with the skin can result in loss of skin oils and can irritate the skin!

- Avoid contact and swallowing.
- Wear protective gloves.
- After any contact, wash the skin with soap and water, and then apply a skin care product.
- Immediately change soaked clothing and shoes.

**⚠ WARNING**

Risk of slipping due to spilled diesel fuel, particularly in combination with water.

- Immediately collect spilled diesel fuel using an oil-binding agent and dispose of it in accordance with regulations.

**ENVIRONMENT NOTE**

*Diesel fuel is a water-polluting substance!*

- Always store in regulation containers.
- Avoid spilling diesel fuel.
- Immediately collect spilled diesel fuel using an oil-binding agent and dispose of it in accordance with regulations.

## Safety regulations for handling consumables

### Coolant and cooling fluid



#### **WARNING**

Coolant and cooling fluid can be hazardous to your health and the environment!

Coolants are chemical corrosion inhibitors and cooling system protecting agents such as Glysantin. Cooling fluid is an appropriate mixture of water and coolant. Coolant in both concentrated and dilute form can be hazardous to your health if swallowed, or hazardous to the environment if spilled.

- Store coolant and cooling fluid only in their original containers and do not spill them.
- Never store coolant or cooling fluid in empty food containers, bottles or other containers.
- Observe the national regulations for the country of use.



#### **ENVIRONMENT NOTE**

- Soak up any spilt coolant or cooling fluid immediately using an oil binding agent and dispose of it in accordance with the national regulations for the country of use.
- Dispose of old coolant or cooling fluid in accordance with the national regulations for the country of use.

### Disposal of consumables



#### **ENVIRONMENT NOTE**

*Materials that accumulate during repair, maintenance and cleaning must be collected properly and disposed of in accordance with the national regulations for the country in which the truck is being used. Work must only be carried out in areas designated for that purpose. Care must be taken to minimise any environmental pollution.*

- Soak up any spilt fluids such as hydraulic oil or gearbox oil immediately using an oil-binding agent.

- Neutralise any spilt battery acid immediately.
- Always observe national regulations concerning the disposal of used oil.

## Emissions

## Emissions

The values specified apply to a standard truck (compare the specifications in the "Technical data" chapter). Different tyres, lift masts, additional units etc. may produce different values.

## Noise emissions

The values were determined based on measuring procedures from the standard EN 12053 "Safety of industrial trucks. Test methods for measuring noise emissions", based on EN 12001, EN ISO 3744 and the requirements of EN ISO 4871.

This machine emits the following sound pressure level:

**Continuous sound pressure level in the driver's compartment**

$L_{pAZ}$	Measurement uncertainty $K_{pA}$
< 75.0 dB(A)	4 dB(A)

The values were determined in the test cycle on an identical machine from the weighted values for operating statuses and idling.

Time proportions:

- Lifting 18%
- Idling 58%
- Driving 24%

However, the indicated noise levels at the truck cannot be used to determine the noise emissions at workplaces according to the most recent version of **Directive 2003/10/EC** (daily personal noise pollution). If necessary, these noise emissions should be determined by the operating company directly at the workplace under the actual conditions there (additional noise sources, special application conditions, sound reflections).

**NOTE**

*Please note the definition of "operating company" in the sense of responsible persons!*

## Vibrations

The vibrations of the machine have been determined on an identical machine in accordance with the standards DIN EN 13059 "Safety of industrial trucks - Test methods for measuring vibration" and DIN EN 12096 "Mechanical vibration - Declaration and verification of vibration emission values".

### Frequency-weighted effective value of acceleration on the seat

MSG 65 driver's seat	Measurement uncertainty
< 0.31 m/s <sup>2</sup>	0.093 m/s <sup>2</sup>

Tests have indicated that the amplitude of the hand and arm vibrations on the steering wheel or the operating devices in trucks is less than 2.5 m/s<sup>2</sup>. There are therefore no measurement guidelines for these measurements.

The personal vibration load on the driver over a working day must be determined by the operating company at the actual place of use in accordance with **Directive 2002/44/EC**, in order to consider all additional influences, such as driving route, intensity of use etc.

#### NOTE

*Please note the definition of "operating company" in the sense of responsible persons!*

## Emissions

### Exhaust gases

#### DANGER

##### **Risk to health from exhaust gases!**

Exhaust gases from internal combustion engines are harmful to your health. In particular, the soot particles contained in the diesel exhaust gas can cause cancer.

When the internal combustion engine is running, there is a risk of poisoning from the CO, CH and NOx components contained in the exhaust gas.

Modern exhaust gas treatment systems (e.g. catalytic converters, particle filters or comparable systems) can clean exhaust gases in a way that reduces the health hazard and risk of poisoning when operating the truck.

- Always observe the national laws and regulations of the country of use when using trucks with an internal combustion engine in entirely or partially enclosed working areas.
- Always ensure sufficient ventilation.

### Heat



#### DANGER

##### **Risk of burns due to hot exhaust gases!**

Exhaust gases or components that carry exhaust gases (e.g. exhaust pipes) can become so hot that direct body contact can cause burns to the skin and materials that are too close can be burned or singed.

- Do not grasp or touch hot exhaust pipes.
- Keep combustible materials away from the exhaust pipe.
- In the event of burns, seek first aid immediately.
- If materials are burning, take fire protection measures immediately.

## Battery



### **⚠ DANGER**

#### **Risk of explosion due to flammable gases!**

During charging, the battery releases a mixture of oxygen and hydrogen (detonating gas). This gas mixture is explosive and must not be ignited.

- Make sure that there is always sufficient ventilation in working areas that are fully or partially enclosed
  - Keep away from open flames and flying sparks
  - Observe the safety regulations for handling the battery.
-





4

---

## Overviews

## Overview

## Overview

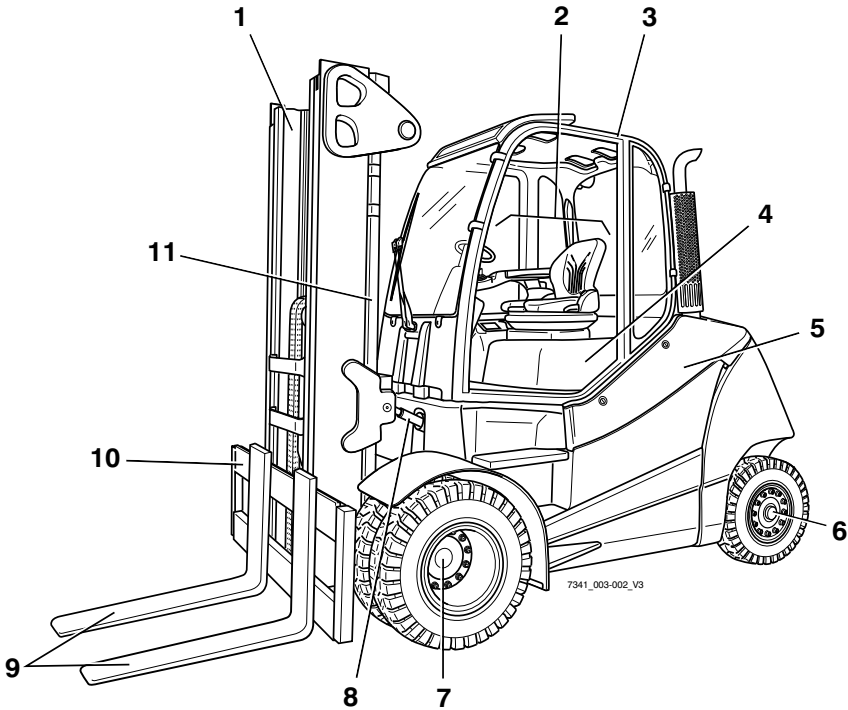

- |   |                         |    |               |
|---|-------------------------|----|---------------|
| 1 | Lift mast               | 7  | Drive axle    |
| 2 | Driver's compartment    | 8  | Tilt cylinder |
| 3 | Overhead guard          | 9  | Fork arms     |
| 4 | Bonnet                  | 10 | Fork carriage |
| 5 | Battery maintenance lid | 11 | Lift cylinder |
| 6 | Steering axle           |    |               |

## Overview of the driver's compartment

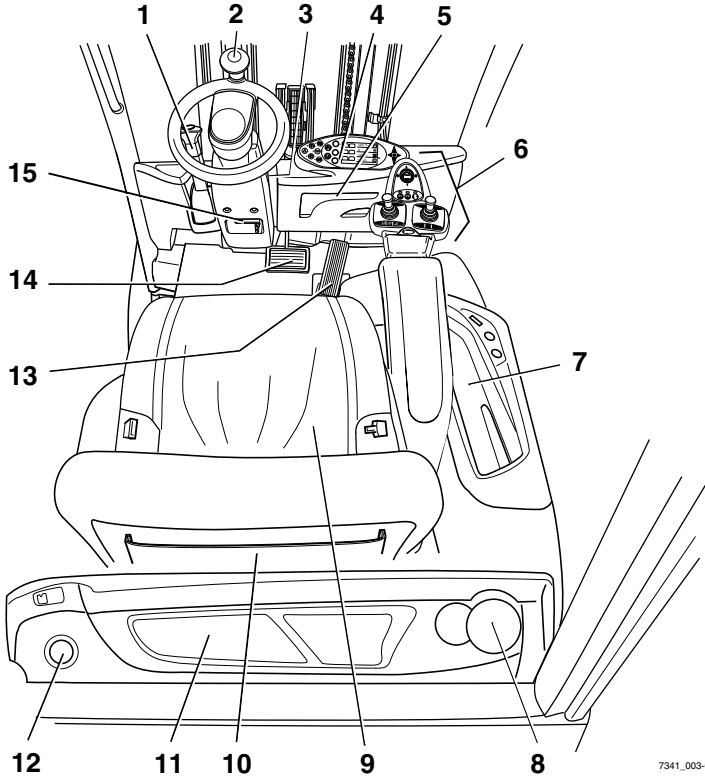

7341\_003-022

- |   |  |    |   |
|---|--|----|---|
| 1 | Parking brake lever                                    | 9  | Driver's seat   |
| 2 | Steering wheel   | 10 | Compartment and potential storage location for operating instructions |
| 3 | Key switch   | 11 | Compartment   |
| 4 | Display and operating unit                             | 12 | Filler cap for windscreen washer reservoir                            |
| 5 | Document holder  | 13 | Accelerator pedal   |
| 6 | Operating devices for hydraulic and traction functions | 14 | Brake pedal   |
| 7 | Compartment  | 15 | Steering column adjustment  |
| 8 | Bottle holder for max. 1.5 l bottles                   |    |   |

**i** NOTE

*The truck equipment may differ from the equipment shown.*

## Operating devices and display elements

## Operating devices and display elements

## Display and operating unit

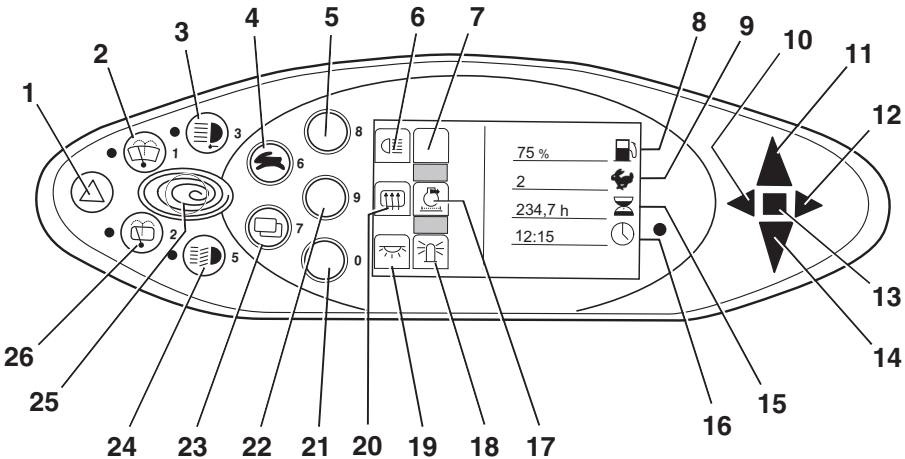

7314\_003-043

1	Hazard warning system button	15	Operating hours display
2	Front windscreen wiper button	16	Time display (digital)
3	Working spotlight button	17	Particle filter display
4	Drive programme selector button	18	Rotating beacon display
5	Lighting button	19	Interior lighting display
6	Lighting symbol	20	Rear window heating display
7	Not assigned	21	Interior lighting/rotating beacon button
8	Fuel level display (percentage)	22	Rear window heating/particle filter regeneration button
9	Drive programme display (numerical)	23	Menu change button
10	Left turn indicator display	24	Lighting button
11	Forward travel indicator	25	Blue-Q button
12	Right turn indicator display	26	Rear window wiper button
13	Malfunction display		
14	Reverse travel indicator		

 **NOTE**

*Buttons (5, 21, 22) and the accompanying display elements (6, 7, 17, 18, 19, 20) are assigned according to the equipment variants in use.*

The assignment shown here is an example and may differ from the assignment actually programmed on the truck. Buttons may be assigned multiple functions that are called up according to the menu navigation. For further information, see the "Operating the display and operating unit" chapter.

- If you have any questions, please contact your authorised service centre.

## Operating devices for hydraulic and driving functions

Different versions of the operating devices are available for operating the truck's hydraulic and traction functions.

The truck can be equipped with the following operating devices:

- **Double mini-lever**
- **Triple mini-lever**
- **Quadruple mini-lever**
- **Joystick 4Plus**
- **Fingertip switch**
- **Mini-console**

## Operating devices and display elements

## Double mini-lever

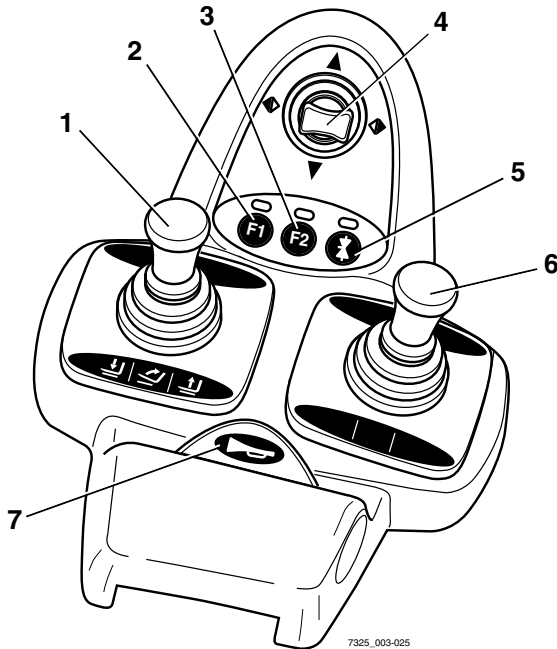

- |   |  |   |                             |
|---|--|---|-----------------------------|
| 1 | "Lift mast" 360° lever                       | 5 | Function key "5th function" |
| 2 | Function key F1                              | 6 | "Attachments" cross lever   |
| 3 | Function key F2                              | 7 | Signal horn button          |
| 4 | "Drive direction/turn indicator" cross lever |   |                             |

 **NOTE**

*Depending on the equipment, various electric attachment parts can be controlled via function keys (2) and (3). Changes must only be made by the STILL service centre.*

## Three-way mini-lever

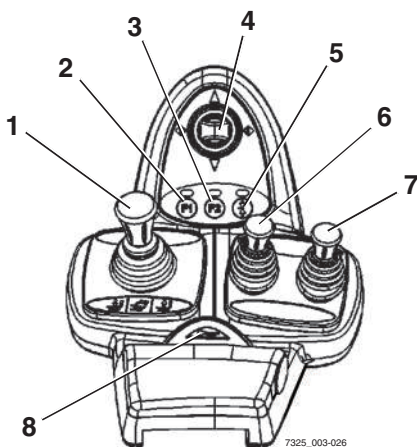

- |   |  |   |  |
|---|--|---|--|
| 1 | "Lift mast" 360° lever                       | 5 | Function key "5th function"              |
| 2 | Function key F1                              | 6 | "Auxiliary hydraulics 1" operating lever |
| 3 | Function key F2                              | 7 | "Auxiliary hydraulics 2" operating lever |
| 4 | "Drive direction/turn indicator" cross lever | 8 | Signal horn button                       |

### NOTE

*Depending on the equipment, various electric attachment parts can be controlled via function keys (2) and (3). Changes must only be made by the STILL service centre.*

## Operating devices and display elements

## Four-way mini-lever

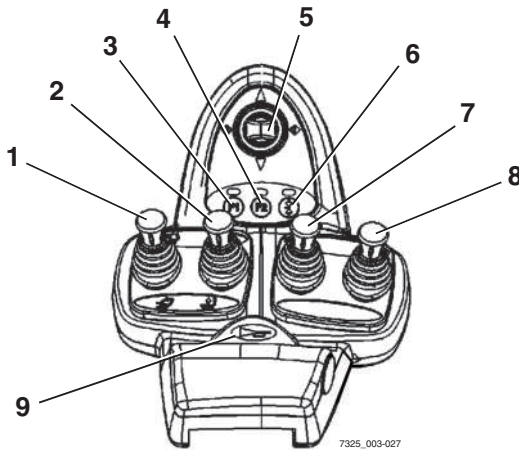

- |   |  |   |  |
|---|--|---|--|
| 1 | "Lift/lower" operating lever                 | 6 | Function key "5th function"              |
| 2 | "Tilt" operating lever                       | 7 | "Auxiliary hydraulics 1" operating lever |
| 3 | Function key F1                              | 8 | "Auxiliary hydraulics 2" operating lever |
| 4 | Function key F2                              | 9 | Signal horn button                       |
| 5 | "Drive direction/turn indicator" cross lever |   |  |

**i** NOTE

*Depending on the equipment, various electric attachment parts can be controlled via function keys (3) and (4). Changes must only be made by the STILL service centre.*



### Joystick 4Plus

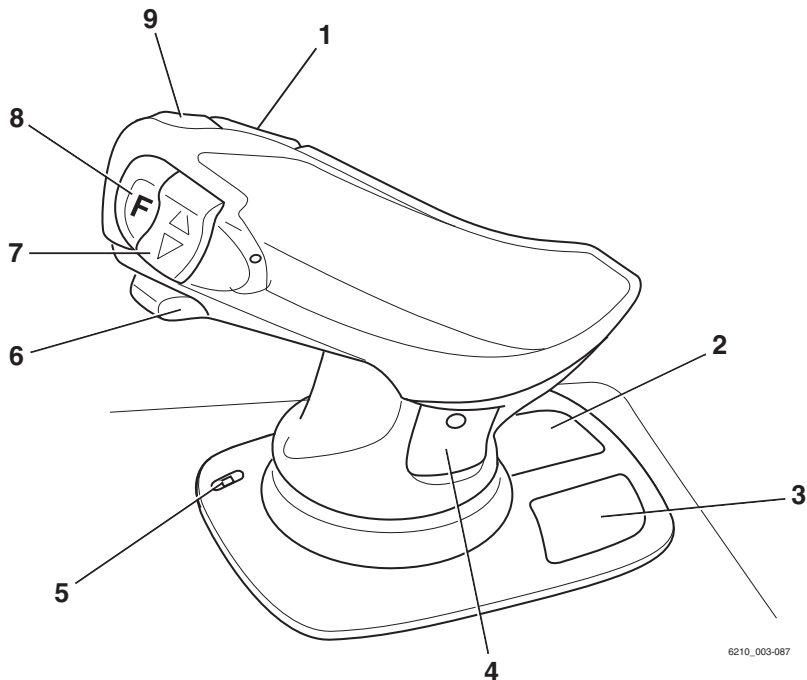

6210\_003-087

- |   |   |   |  |
|---|---|---|--|
| 1 | Horizontal rocker button for "3rd hydraulic function", tilt the lift mast           | 5 | LED for clamp locking mechanism (variant)                                    |
| 2 | Pictograms for the basic hydraulic functions  | 6 | Slider for the "4th hydraulic function", e.g. reach frame forwards/backwards |
| 3 | Pictograms for the 5th hydraulic function and the clamp locking mechanism (variant) | 7 | Vertical rocker button for the "drive direction"                             |
| 4 | Pictograms for the 3rd & 4th hydraulic functions                                    | 8 | Shift key "F"  |
|   |   | 9 | Signal horn button   |

## Operating devices and display elements

## Fingertip

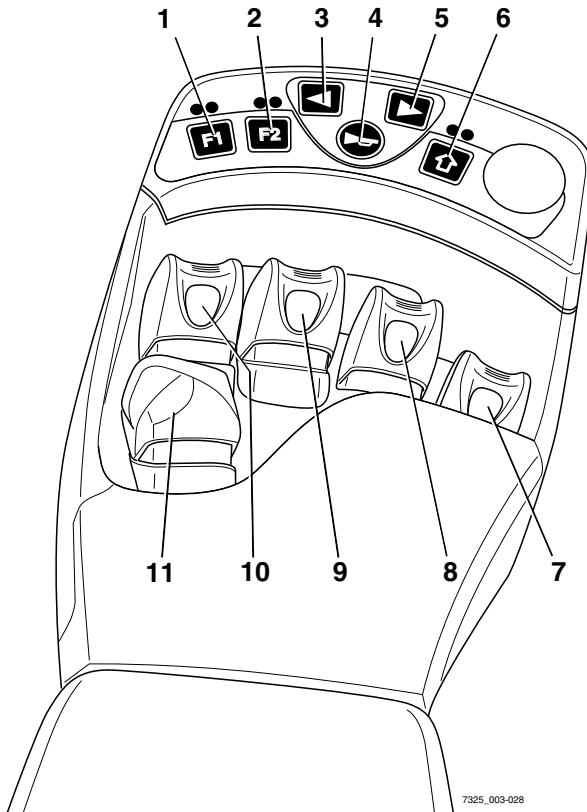

- |   |                             |    |                               |
|---|-----------------------------|----|-------------------------------|
| 1 | Function key F1             | 7  | "Attachments" operating lever |
| 2 | Function key F2             | 8  | "Attachments" operating lever |
| 3 | Left turn indicator button  | 9  | "Tilt" operating lever        |
| 4 | Signal horn button          | 10 | "Lift/lower" operating lever  |
| 5 | Right turn indicator button | 11 | Drive direction switch        |
| 6 | Function key "5th function" |    |                               |

 NOTE

Depending on the equipment, various electric attachment parts can be controlled via function keys (1) and (2). Changes must only be made by the STILL service centre.

### Mini console

The mini console is located on the steering column below the steering wheel.

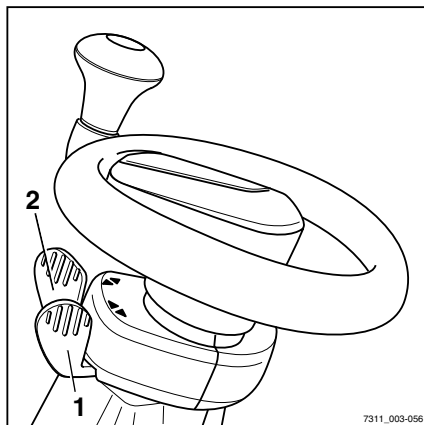

- 1 Travel direction switch
- 2 Direction indicator switch

Labelling points

Labelling points

Overview

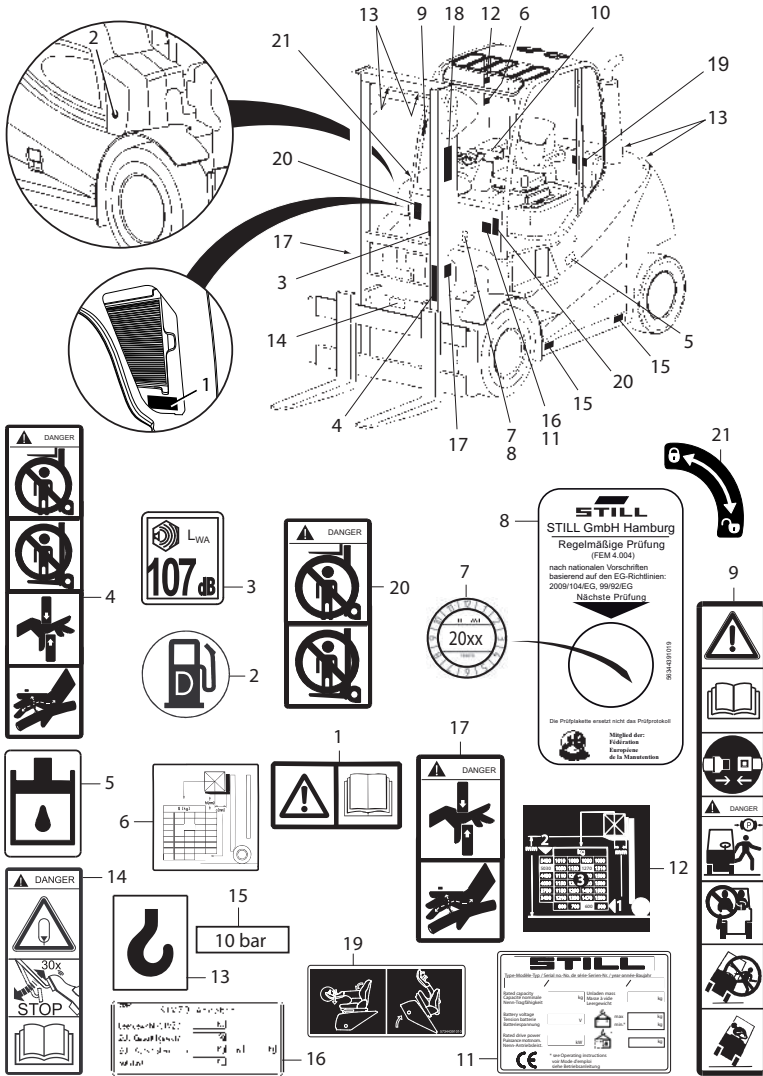

7341\_003-016\_V5

- |    |   |    |   |
|----|---|----|---|
| 1  | Decal information: Caution/read the operating instructions  | 12 | Decal information: Capacity rating plate  |
| 2  | Decal information: Diesel fuel  | 13 | Decal information: Lifting gear attachment point  |
| 3  | Decal information: Sound power level  | 14 | Warning sign: Actuate accumulator/brake pedal 30x /read operating instructions  |
| 4  | Warning sign: Do not stand underneath the fork/Do not stand on the fork/Danger due to shearing/Danger due to high fluid pressure  | 15 | Decal information: Tyre filling pressure  |
| 5  | Decal information: Hydraulic oil tank   | 16 | Decal information: StVZO (German Road Traffic Licensing Regulations) information (variant)  |
| 6  | Decal information: Attachment capacity rating plate   | 17 | Warning sign: Danger due to shearing/Danger due to high fluid pressure  |
| 7  | Decal information: Inspection sticker   | 18 | Manufacturer's label text   |
| 8  | Decal information: FEM test   | 19 | Decal information: Before opening the bonnet, slide the seat forwards, lower the armrest and fold the seat backrest down. Then open the bonnet. |
| 9  | Decal information: Caution/Read the operating instructions/Fasten seat belt/Apply parking brake when leaving the truck/Passengers are not allowed/Do not jump off if the truck is tipping over/Lean in the opposite direction to which the truck is tilting | 20 | Warning sign: Do not stand underneath the fork/Do not stand on the fork   |
| 10 | Manufacturer's label text   | 21 | Decal information: To unlock, turn 90° to the right/to lock, turn 90° to the left   |
| 11 | Decal information: Nameplate  |    |   |

## Labelling points

## Nameplate

The truck can be identified from the information on the nameplate.

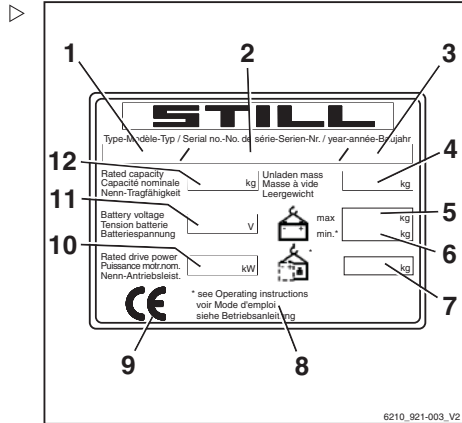

- 1 Type
- 2 Production number
- 3 Year of manufacture
- 4 Tare weight in kg
- 5 Max. permissible battery weight in kg (for electric forklift trucks only)
- 6 Min. permissible battery weight in kg (for electric forklift trucks only)
- 7 Ballast weight in kg (for electric forklift trucks only)
- 8 Refer to the technical data listed in these operating instructions for more detailed information
- 9 CE labelling
- 10 Nominal drive power in kW
- 11 Battery voltage in V
- 12 Rated capacity in kg

### Production number

**i** NOTE

The production number is used to identify the truck. It can be found on the nameplate and must be referred to in all technical questions.

The production number contains the following coded information:

- (1) Production location
- (2) Model
- (3) Year of manufacture
- (4) Sequential number

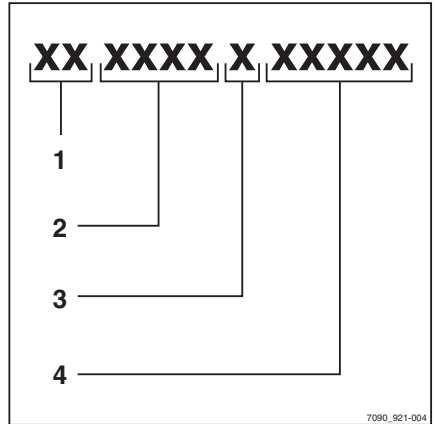

### StVZO (Road Traffic Licensing Regulations) information

This label includes information on the weight and load distribution of the truck.

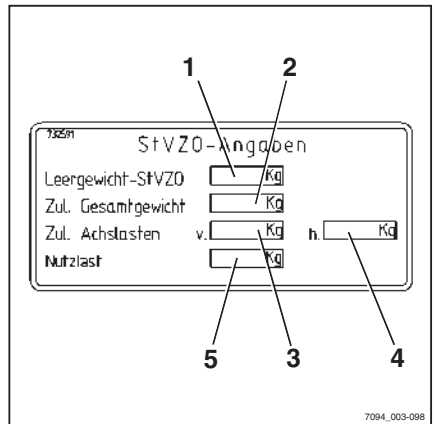

- 1 Tare weight (in kg)
- 2 Permitted total weight (in kg)
- 3 Permitted front axle weight (in kg)
- 4 Permitted rear axle weight (in kg)
- 5 Payload (in kg)





**5**

---

**Operation**

## Checks and tasks to be carried out prior to commissioning

## Checks and tasks to be carried out prior to commissioning

## Visual inspections

**▲ WARNING**

Risk of accident due to damage or other defects on the truck or on the attachment (variant)!

Damage to the truck or the attachment (variant) can lead to unpredictably dangerous situations. If damage or other defects are identified on the truck or attachment (variant) during the following inspections, the truck may not be used until it has been properly repaired.

- Do not remove or deactivate safety systems or switches.
- Do not change any predefined set values.
- Do not use the truck until it has been properly repaired.

**▲ WARNING**

There is a risk of falling when working on high parts of the truck.

- Use only the steps provided on the truck.
- Do not stand on truck components or use them to help you mount the truck.
- Use suitable equipment.

Prior to start-up, ensure that the truck is safe to be operated:

- The fork arms must be secured against lifting and shifting.
- The locking devices (1) of the fork arms must not be damaged or deformed.
- Fork arms and other lifting accessories must not show any noticeable damage (e.g. bends, cracks, significant wear).
- The roller tracks (2) must be lubricated with a visible grease film.
- The chains must not be damaged and they must be evenly and adequately tensioned.
- Check the area under the forklift truck for leaking consumables.
- The guard grille (variant) and overhead guard must be undamaged and securely mounted.

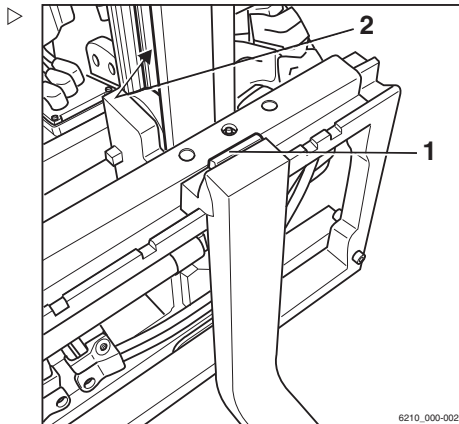

- Attachments (variant) must be properly mounted and function according to the operating instructions.
- All decal information signs must be in place and legible. Replace damaged or missing adhesive labels in accordance with the overview in the "Identification points" chapter.
- Any warning units (e.g. signal horn) must be in perfect condition and function correctly
- Check the visible areas of the hydraulic system and hydraulic oil tank for damage and leaks. Damaged hoses must be replaced by the authorised service centre
- Check the visible areas of the fuel system and fuel tank for damage and leaks. Damaged hoses must be replaced by the authorised service centre
- The bonnet and side flap must be locked securely.
- Steps must be clean and free of ice.
- Any panes of glass (variant, e.g. wind-screen) must be clean and free of ice.
- Depending on the tyres, the truck may be fitted with an antistatic belt. The antistatic belt must not be damaged. It must also be clean and long enough to touch the ground
- The coupling pin in the counterweight must show no noticeable damage (e.g. bends, cracks or breaks). The securing bush in the counterweight must be present.
- A tow coupling (variant) must show no noticeable damage (e.g. coupling pin bent, cracks or breaks). Every removable coupling pin must be secured against loss with a securing device (e.g. a chain, a split pin or a rope).
- Damage or other defects on the truck or attachment (variant) must be reported to the supervisor or responsible fleet manager immediately so that they can arrange for the defect to be rectified.

## Checks and tasks to be carried out prior to commissioning

### Filling the washer system

#### ⚠ CAUTION

Components may become damaged due to the effects of frost!

Water expands when it freezes. If there is no anti-freeze in the washer system, the system may be damaged due to the build up of ice in freezing conditions.

- Always use washer fluid containing anti-freeze.

The windscreen washer reservoir is under the compartment behind the driver's seat. The sight glass (1) displays the fill level.

- Open filler cap (2) for the windscreen washer reservoir.
- Fill the windscreen washer reservoir with washer fluid and anti-freeze in accordance with the maintenance data table; see ⇒ Chapter "Maintenance data table", P. 6-313.
- Close lid.
- Operate washer system until washer fluid is discharged from the spray nozzles.

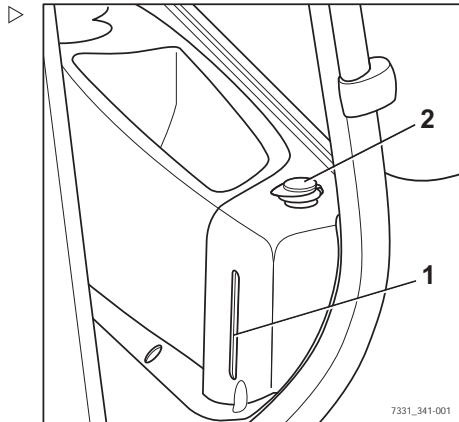

### Checking the condition of the wheels and tyres

#### ⚠ WARNING

Risk of accidents! With uneven wear or incorrect air pressure, the stability of the forklift truck decreases and the braking distance increases.

- Change worn or damaged tyres without delay.

**⚠ WARNING**

Risk of tipping!

Tyre quality affects the stability of the truck.

If you wish to use a different type of tyre on the truck from the tyres approved by the truck manufacturer, or tyres from a different manufacturer, you must first obtain approval from the truck manufacturer.

**⚠ WARNING**

Risk to stability!

When using pneumatic tyres or solid rubber tyres, rim wheel parts must never be changed and rim wheel parts from different manufacturers must not be mixed.

**i NOTE**

*Only approved types of tyre may be used; see chapter entitled "Tyres".*

- Check tyres (1) for wear or damage.

Tyres must not be damaged or excessively worn. They must be worn evenly on both sides.

- In the case of pneumatic tyres, check the air pressure. The air pressure indicated on the adhesive labels (2) must be observed.

**i NOTE**

*Observe the safety principles outlined in the chapter entitled "Tyres".*

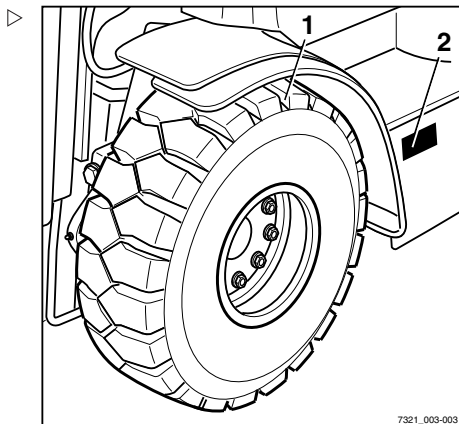

## Checks and tasks to be carried out prior to commissioning

### Checking the cooling fluid level

The coolant level is monitored by a sensor.

As soon as the **COOLANT LEVEL** message appears on the display, proceed as described below.

#### **⚠ WARNING**

Risk of scalding due to hot cooling fluid!

The cooling system is pressurised! Opening the cooling fluid tank (1) may result in hot cooling fluid leaking out. Only open the cooling fluid tank when the cooling system is cool.

- Switch off the engine and allow it to cool down.
- Do not open the cooling fluid tank until the truck has cooled down.

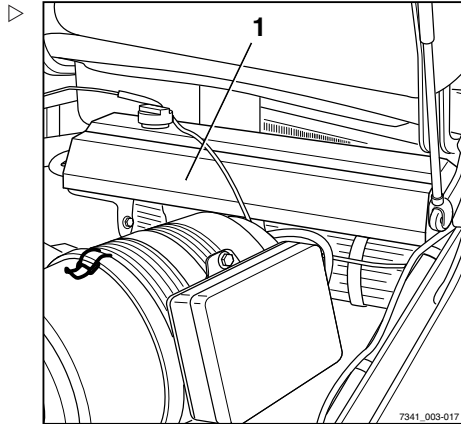

#### **⚠ WARNING**

Coolant and cooling fluid can pose a hazard to health and the environment!

- Observe the safety regulations set out in the section entitled "Coolant and cooling fluid".
- Top up the cooling fluid if necessary; refer to the section entitled "Topping up the cooling fluid and checking the coolant concentration".

#### **⚠ CAUTION**

Risk of engine damage!

If the coolant level is low, this indicates a leakage in the cooling system.

- Check the cooling system for leaks; see the section entitled "Cleaning the radiator, checking for leaks".

### Checking the engine oil level

#### **i NOTE**

*To determine the oil level exactly, the truck must be horizontal when checking.*

- Ensure that the truck is parked in a horizontal position.
- Open the bonnet.

## Checks and tasks to be carried out prior to commissioning

- Stand on the bottom plate of the driver's cab and turn your body slightly to the left as shown. ▷

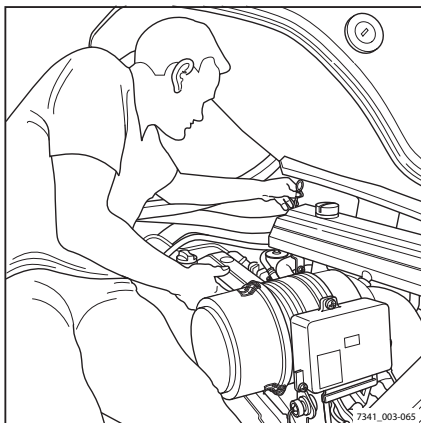

- Using both hands, pull out the oil dipstick (1) and wipe it using a cloth. ▷

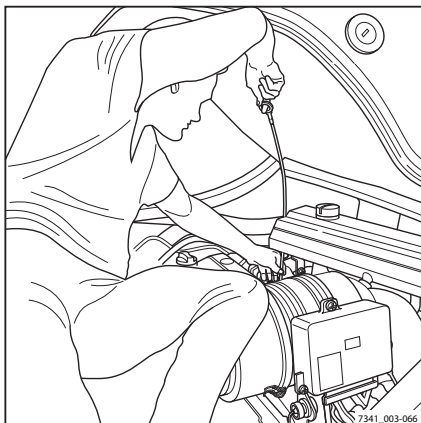

## Checks and tasks to be carried out prior to commissioning

- Insert the oil dipstick (1) as far as it will go and pull it out again. ▷

The oil level must be between the marks (arrows).

- If the oil level reaches only up to the lower marking, fill oil in accordance with the maintenance data table.
- Insert the oil dipstick to the stop.
- Close the bonnet.

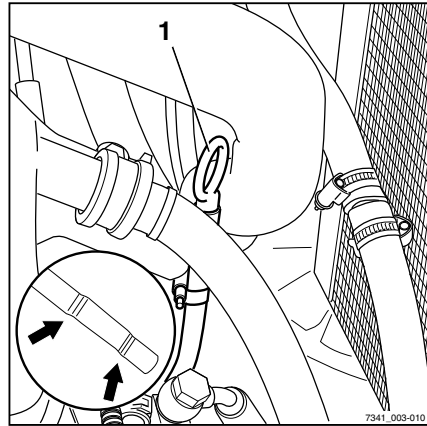

## Adjusting the MSG 65/MSG 75 driver's seat

### ⚠ DANGER

**There is a risk of accident if the seat or seat backrest shifts suddenly, which could cause the driver to move in an uncontrolled manner. This can result in unintentional actuation of the steering or the operating devices and thus cause uncontrolled movements of the truck or load.**

- Do not adjust the seat or seat backrest while driving.
- Adjust the seat and seat backrest so that all operating devices can be actuated safely.
- Ensure that the seat and seat backrest are securely engaged.



### ⚠ WARNING

On some equipment variants, the amount of head clearance on the truck may be restricted.

On these specific equipment variants, the distance between the head and the lower edge of the roofing sheet must be at least 40 mm.

### 📘 NOTE

*If there are separate operating instructions for the seat, they must be followed.*



**⚠ WARNING**

To obtain optimum seat cushioning, you must adjust the seat suspension to your own body weight. This is better for your back and protects your health.

- To prevent injury, make sure that there are no objects within the seat's swivel area.

**Moving the driver's seat**

- Lift the lever (1) and hold.
- Push the driver's seat into the desired position.
- Release the lever.
- Ensure that the driver's seat is securely engaged.

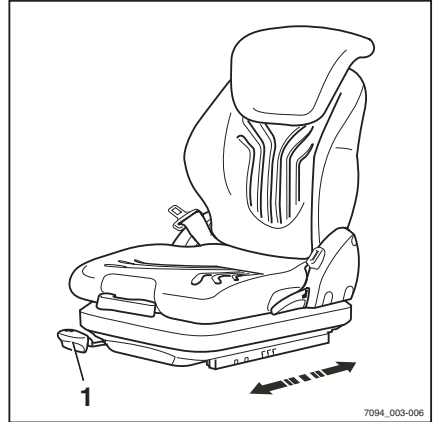
**Adjusting the seat backrest**

Do not put pressure on the seat backrest while engaging it.

- Lift the lever (2) and hold.
- Push the seat backrest into the desired position.
- Release the lever.
- Ensure that the seat backrest is securely engaged.

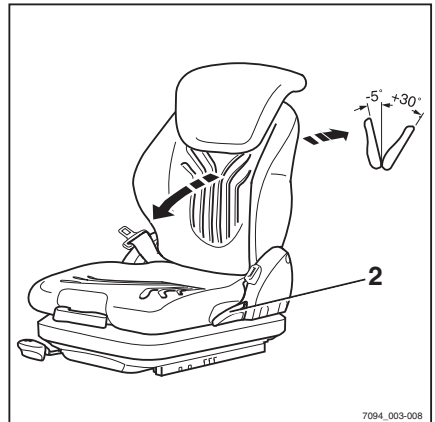
**i NOTE**

*The backwards tilt angle of the seat backrest can be restricted by the structural condition of the truck.*

## Checks and tasks to be carried out prior to commissioning

## Adjusting the seat suspension

**i** NOTE

The driver's seat can be adjusted to suit the weight of the individual driver. In order to achieve the best seat suspension setting, the driver should perform the adjustment whilst sitting in the seat.

**i** NOTE

The MSG 75 seat is equipped with electric air suspension activated with an electric switch instead of a lever (3).

- Fully extend weight adjusting lever (3).
- Pump it up or down to set the driver's weight.
- Return the weight adjusting lever to the central initial position before each new lift (audible click).
- Fully fold in the weight adjusting lever once adjustment is complete.

**i** NOTE

The correct driver's weight has been selected when the arrow (4) is in the centre of the inspection window. A noticeable empty lift on the weight adjusting lever shows that you have reached the minimum or maximum weight setting.

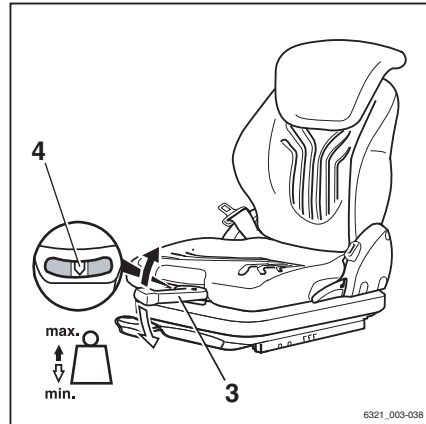

## Adjusting the lumbar support (variant)

**i** NOTE

The lumbar support can be adjusted to suit the contours of the individual driver's spine. Adjusting the lumbar support moves a convex support cushion into the upper or lower part of the backrest.

- Turn the turning knob (5) up or down until the lumbar support is in the desired position.

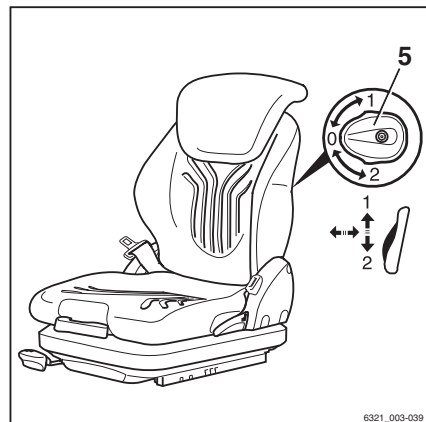

### Adjusting the backrest extension (variant)

- Adjust the backrest extension (6) by pulling it out or pushing it into the desired position.

To remove the backrest extension, move it past the end stop by jolting it upwards.

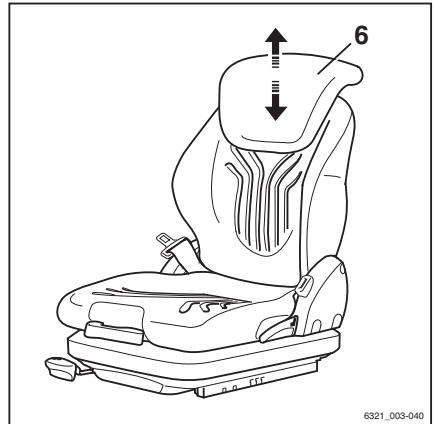

### Switching the seat heater (variant) on and off



#### NOTE

*The seat heater only functions if the seat contact switch is active, i.e. when the driver is sitting on the driver's seat.*

- Switch the seat heater (7) on or off using the switch.

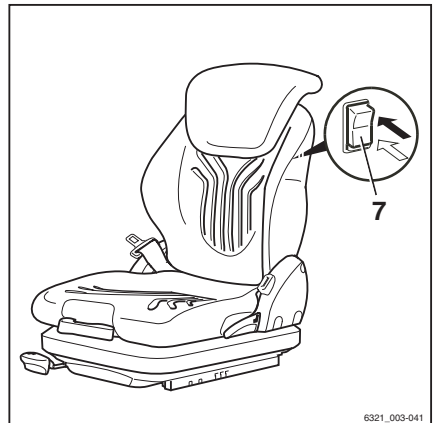

### Adjusting the armrest

#### **⚠ DANGER**

**There is a risk of accident if the armrest lowers suddenly, causing the driver to move in an uncontrolled manner. This can result in unintentional actuation of the steering or the operating devices and thus cause uncontrolled movements of the truck or load.**

- Do not adjust the armrest while driving.
- Adjust the armrest so that all operating devices can be actuated safely.
- Ensure that the armrest is securely tightened.

## Checks and tasks to be carried out prior to commissioning

**Adjusting the length of the armrest**

- Release the star-grip handle (1) by turning it anti-clockwise.
- Shift the armrest (2) into the desired position.
- Tighten the star-grip handle by turning it clockwise.
- Check that the armrest is firmly attached.

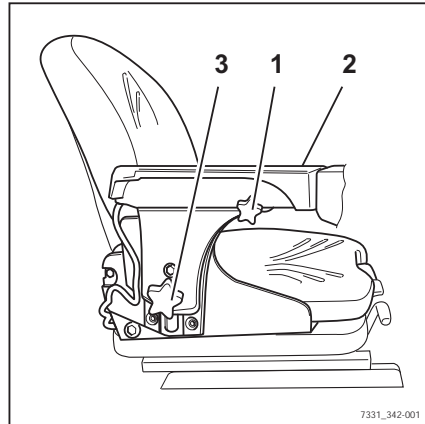
**Adjusting the height of the armrest**

- Release hand wheel (3) by turning it anti-clockwise.
- Shift the armrest (2) into the desired position.
- Tighten the hand wheel by turning it clockwise.
- Check that the armrest is firmly attached.

**Adjusting the steering column**

- Press down the steering column adjustment lever (2).
- Position the steering column (1) and pull the lever up again.

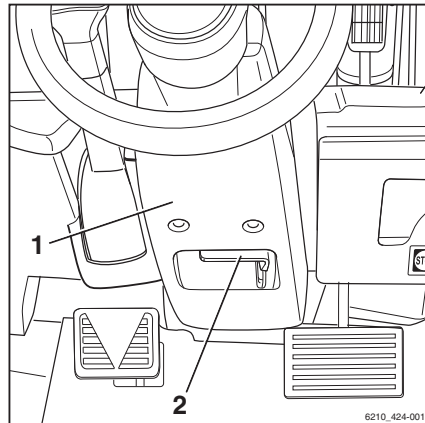
**⚠ DANGER****Risk of accidents!**

- Ensure that the steering column is secure.
- The steering column must click into place.  
 Never adjust the steering column while driving.

### Cleaning the dust valve

- Press the dust valve (1) on the air filter housing between your fingers until no more dust is emitted.

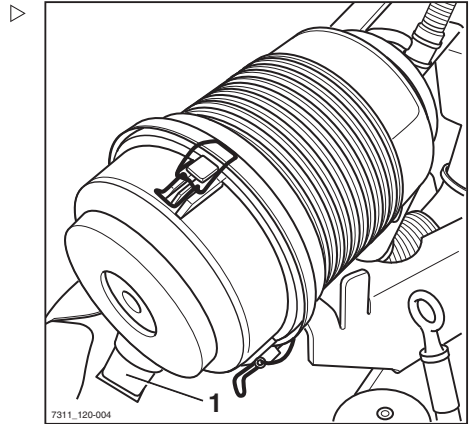

### Checking the pre-cleaner

The pre-cleaner is part of the "heavy dust guard" equipment variant and is mounted at the rear right of the truck. In the pre-cleaner, coarse dust and dirt are removed from the intake air.

#### Checking the pre-cleaner

- Check the dirt level in the pre-cleaner (2).

The pre-cleaner must be cleaned if it is filled to the upper marking (1), see the "Cleaning the pre-cleaner" chapter.

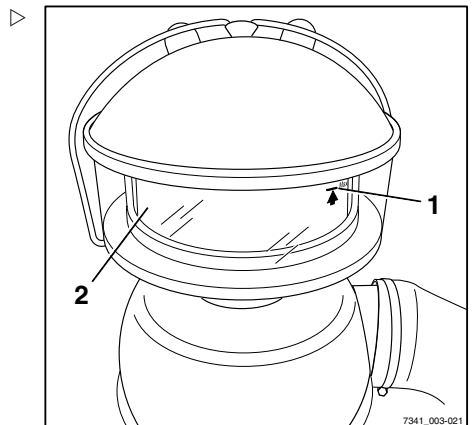

## Checks and tasks to be carried out prior to commissioning

### Checking the oil tank on the oil bath air filter ▷

The oil bath air filter is a further variant of the "heavy dust guard" equipment variant and is mounted on the rear right of the truck. The oil bath air filter filters finer dust and dirt particles that have passed through the pre-cleaner out of the intake air.

#### **⚠ WARNING**

There is a risk of slipping on spilled oil, particularly when combined with water!

The oil tank (4) is filled with oil to the level marker (3).

- Carefully remove the oil tank.
- Collect any spilled oil immediately using an oil binding agent and dispose of it in accordance with regulations.
- Observe the safety information for handling oils, see the "Oils" chapter.

- 
- Fold up the four oil tank locking brackets (2).
  - Remove the oil tank from the housing (1).
  - Check the dirt level in the oil tank.

The oil tank must be cleaned if the deposited dirt reaches approximately halfway up to the oil level; see the "Cleaning the oil bath filter" chapter.

- Secure the oil tank with the four locking brackets on the housing.

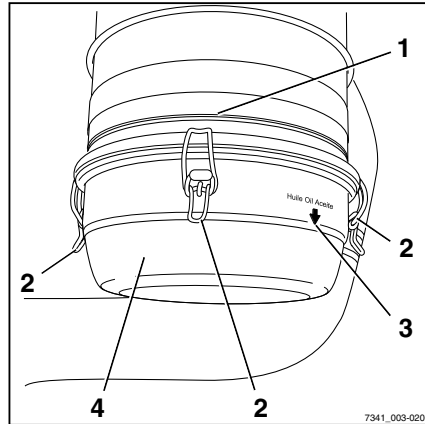

## Commissioning

### Climbing into and out of the truck

#### WARNING

Risk of injury when climbing into and out of the truck due to slipping, striking parts of the truck or becoming stuck!

If the footwell cover is very dirty or smeared with oil, there is a risk of slipping. There is a risk of hitting your head on the overhead guard post or of your clothes becoming stuck when climbing out of the truck.

- Ensure that the footwell cover is non-slip.
- Do not jump into or out of the truck.
- Ensure that you have a secure grip on the truck.

#### WARNING

Risk of injury when jumping out of the truck!

If your clothing or jewellery (e.g. watch, ring etc.) becomes stuck on a component while you are jumping out of the truck, this can lead to serious injuries (e.g. from falling, loss of fingers etc.). It is forbidden to jump out of the truck.

- Do not jump out of the truck.
- Do not wear jewellery at work.
- Do not wear loose-fitting workwear.

#### CAUTION

Components may become damaged through incorrect use!

Truck components, such as the driver's seat, steering wheel, parking brake lever etc., are not designed to be used for climbing in and out of the truck and may be damaged due to misuse.

- Only use the fittings specifically designed for the purpose of climbing into and out of the truck.

#### NOTE

*The foot that the driver starts with when climbing into and out of the truck is crucial in ensuring this action is carried out safely. This will depend on the number of steps. Trucks with a single wheel on the front axle feature two steps. Trucks with two wheels on the front axle feature three steps.*

## Commissioning

**Climbing in and out of trucks featuring a single wheel and two steps**

When climbing into and out of the truck, use the handles (2) and (4) for support. The overhead guard post (1) can also be used for support.

Always **climb into** the truck facing forwards:

- Grip handle (2) with your left hand and hold on.
- Grip handle (4) with your right hand and hold on.
- Place your right foot on the bottom step (5).
- Place your left foot on the top step (6).
- Place your right foot into the footwell (7).
- Enter the truck and sit down on the driver's seat (3).

Always **climb out** of the truck backwards:

- Grip handle (2) with your left hand and hold on.
- Stand up from the driver's seat and place your left foot on the top step (6).
- Grip the handle (4) with your right hand and hold on.
- Place your right foot on the bottom step (5).
- Place your left foot on the ground and climb down from the truck.

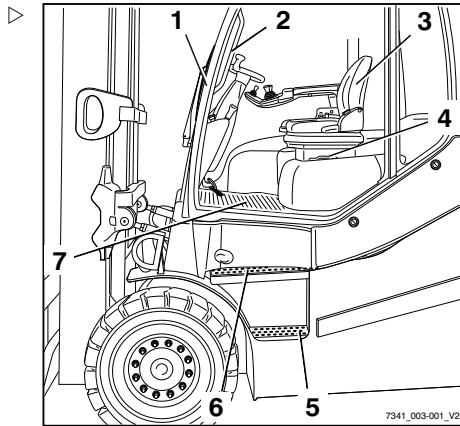



### Climbing in and out of trucks featuring two wheels and three steps

When climbing into and out of the truck, use the handles (2) and (4) for support. The overhead guard post (1) can also be used for support.

Always **climb into** the truck facing forwards:

- Grip handle (2) with your left hand and hold on.
- Grip handle (4) with your right hand and hold on.
- Place your left foot on the bottom step (5).
- Place your right foot on the middle step (6).
- Place your left foot on the top step (7).
- Place your right foot into the footwell (8).
- Enter the truck and sit down on the driver's seat (3).

Always **climb out** of the truck backwards:

- Grip handle (2) with your left hand and hold on.
- Stand up from the driver's seat and place your left foot on the top step (7).
- Grip the handle (4) with your right hand and hold on.
- Place your right foot on the middle step (6).
- Place your left foot on the bottom step (5).
- Place your right foot on the ground and climb down from the truck.

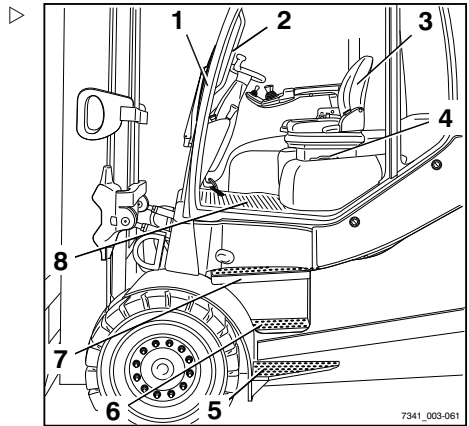

## Commissioning

## Unlocking the emergency off switch ▷

**i** NOTE

*Only trucks with a joystick 4Plus (variant) have an emergency off switch.*

- Pull out the emergency off switch (1) until it unlatches.

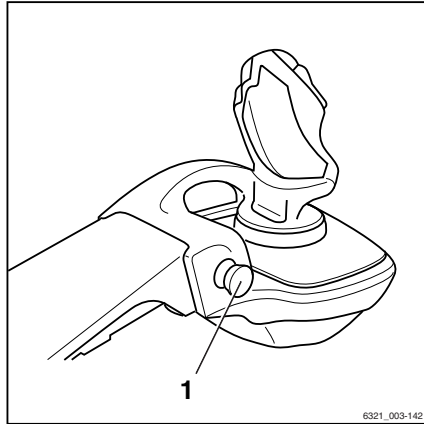

## Switching on the key switch

**⚠** WARNING

Before switching on the key switch, all tests prior to commissioning must be performed without any defects being detected.

- Perform the tests prior to commissioning.
- Do not operate the truck if defects have been detected.
- Notify the authorised service centre.

**i** NOTE

*If the steering is turned when switching on the truck, the truck will travel more slowly. This driving speed limitation is disabled as soon as the truck is steered out of cornering to drive in a straight line. To do this, rotate the steering wheel by approximately half a turn.*

- Insert the switch key (1) into the key switch and turn to position "I".

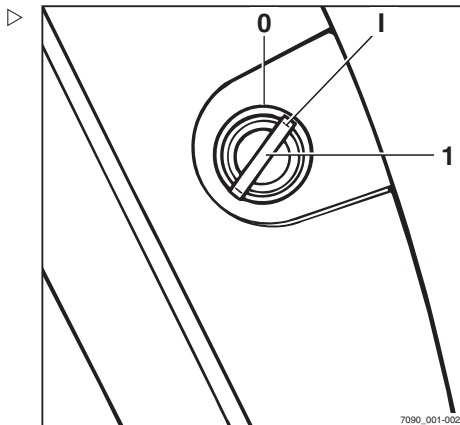

- This initiates a self-test. All lamps in the drive direction and turn indicator displays light up briefly.

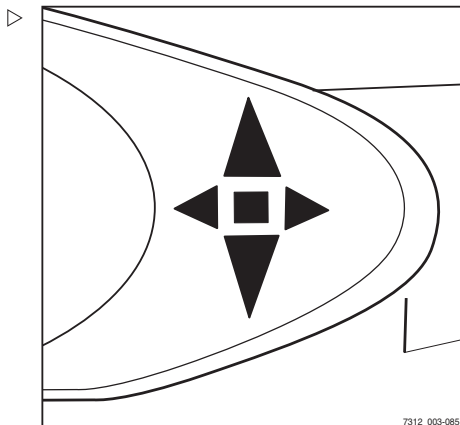

## Commissioning

When the key switch is switched on, the display shows the welcome screen in the set language until the truck controllers have fully started up.



## Standard display elements

In the factory setting, the following indicators can be seen in the display and operating unit:

### 1 Fuel level

Shows the fuel level in the fuel tank as a percentage (%).

### 2 Drive programme

Displays the current drive programme numerically (1-5). The drive programme can be changed; see the chapter entitled "Setting the drive programme".

### 3 Operating hours

Displays the total operating hours completed by the truck. The hour meter operates as soon as the engine is started.

### 4 Time

Displays the current time digitally in hours and minutes. The time can be adjusted; see the chapter entitled "Setting the time".

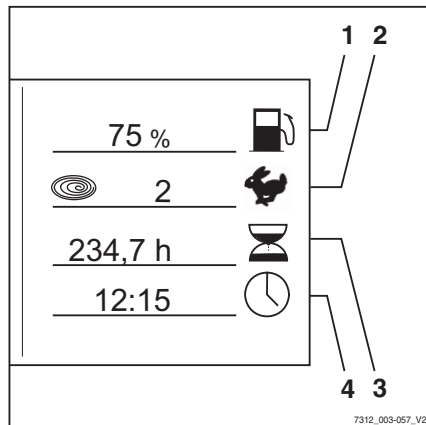

**⚠ CAUTION**

Lack of fuel can cause malfunctions!

If the fuel tank has been run empty, the fuel injection system can draw in air bubbles. This can lead to malfunctions in the fuel injection system.

When the fuel tank is replaced during repair work or because it has been run empty, diesel fuel must be pre-pumped with the fuel hand pump after filling, see the "Using the fuel hand pump" chapter.

- Never run the fuel tank empty.
- If necessary, refuel the truck and pre-pump diesel fuel.

**i NOTE**

*Additional information may appear on the display. If faults occur, refer to the information in the chapter entitled "Faults".*

**Access authorisation with PIN code (variant)****Description**

Trucks equipped with the "Access authorisation with PIN code" variant are protected against unauthorised use by a five-digit driver PIN. Up to fifty different driver PINs can be defined so that the same truck can be used by different drivers, each with their own driver PIN.

**i NOTE**

*The driver PINs are defined in a truck control unit menu that can only be accessed by persons with the corresponding access authorisation, e.g. fleet managers.*

Once the key switch has been switched on, the input menu for the driver PIN appears on the display and operating unit screen. All of the truck's functions (driving, hydraulics, additional electrical installations and the display and operating unit displays) are blocked. The function of the hazard warning system (variant) is guaranteed. Enter the five-digit driver PIN (possible entries from 00000 to 99999) to enable the blocked functions. Once the correct driver PIN has been entered, the

## Commissioning

standard displays are shown. All of the truck functions are available.

The access authorisation can be configured in such a way that the driver PIN has to be re-entered each time the driver steps off the truck, in order for the truck to be operated again.

- Contact the authorised service centre on this matter.

The first driver PIN is preset to "11111" at the factory. All others are preset to "0xFFFF" but have no function as the highest valid driver PIN is "99999". Persons with the corresponding access authorisation, e.g. fleet managers, can change the driver PINs in the corresponding menu.



### NOTE

*When first commissioning the truck, we recommend you change the access authorisation set at the factory. This is the only way to guarantee that the driver PIN is only known to persons with corresponding access authorisation.*

The driver PINs are stored in the truck control unit. These are still available if the display and operating unit has been changed. The authorised service centre can use a diagnostic device to read out the driver PIN and, if necessary, restore the factory default driver PIN.

### ACCESS CODE input menu

The driver enters the five-digit driver PIN (00000 to 99999) in this input menu.

The driver PIN is entered using the buttons (1). The digits entered for the driver PIN (2) are not visible, instead being represented by circles. If the driver PIN entered is correct, the familiar display appears with the standard display, and all truck functions are available.

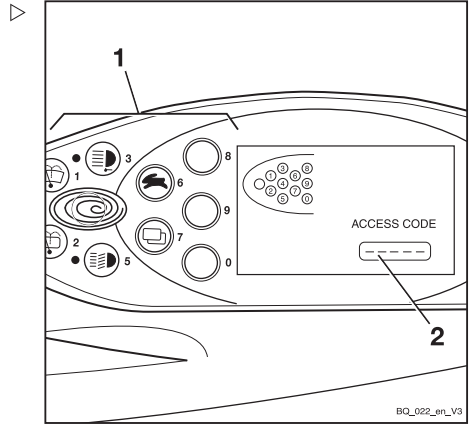

If an incorrect driver PIN is entered, the message **INVALID** appears for a short time. When the message goes out, the driver PIN can be re-entered.

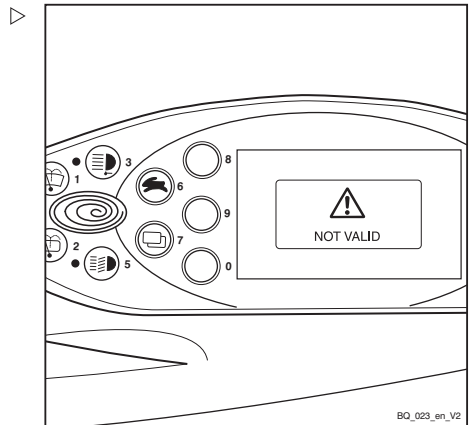

## Commissioning

After three invalid entry attempts, the message **CODE DENIED** appears. The input is then locked for five minutes before another attempt can be made.

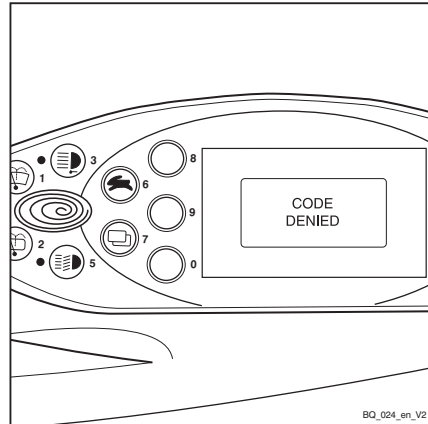

BQ\_024\_en\_V2

## Defining the driver PIN



### NOTE

*The driver PIN can only be defined by persons with the corresponding access authorisation, e.g. fleet managers. In order for the fleet manager to define the driver PIN, the configuration menu must be accessed. The configuration menu is password-protected. After entering the password, the fleet manager can configure general settings for the truck. To change the password, see the chapter entitled "Changing the password".*

- Push the drive program selection button (1) and the menu change button (2) at the same time.

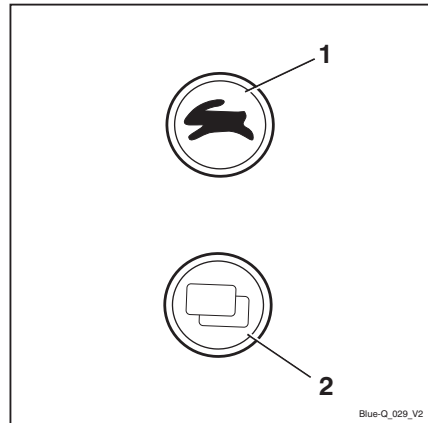

Blue-Q\_029\_V2



PASSWORD appears in the display.

- Enter the four-digit password (factory default: 2777) using the buttons (1).
- Confirm the entry by pressing the **ENTER** button (2).

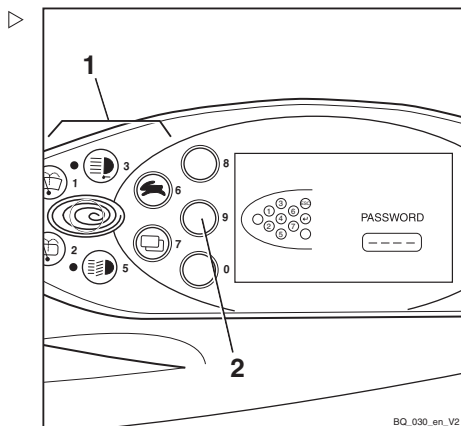

CONFIGURATION appears in the display.

- Use the drive program selection button (1) and the menu change button (3) to select the ACCESS CODE menu.
- Confirm your selection by pressing the **ENTER** button (2).

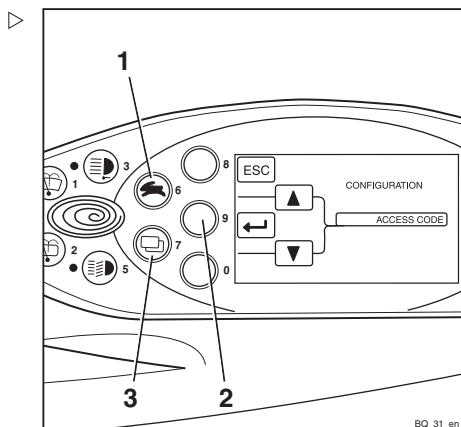

## Commissioning

### Selecting the driver PIN

In the ACCESS CODE menu, there are fifty possible driver PINs to choose from.

The digit sequences can be set or changed in the NEW CODE submenu.

Once the ACCESS CODE menu has been accessed, the CODE selection field (2) contains the number 1. The first of the fifty driver PINs can now be defined.

- Use the drive program selection button (1) and the menu change button (4) to select the desired driver PIN (1 to 50).
- Confirm your selection by pressing the **ENTER** button (3).

NEW CODE appears in the display.

- Enter the desired driver PIN using the buttons (5).

The digits entered do not appear in the display. Instead they are represented by circles in the NEW CODE field (6).

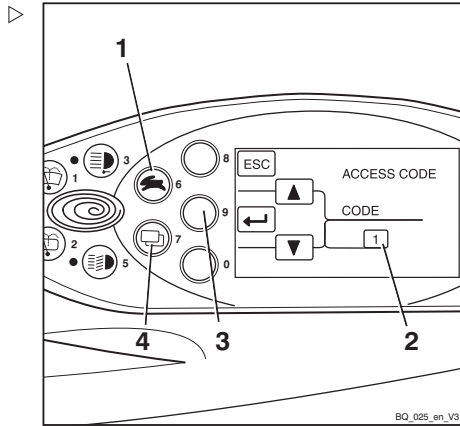

BQ\_025\_en\_V3

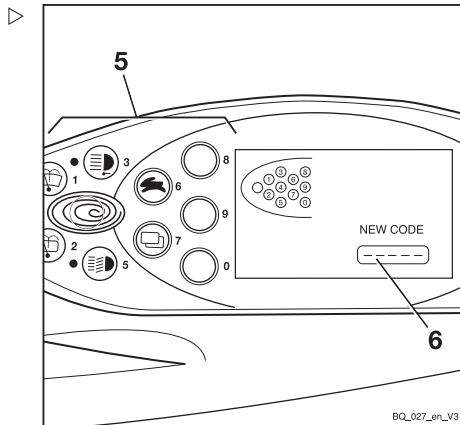

BQ\_027\_en\_V3

CONFIRM appears in the display.

The CONFIRM submenu is used to confirm the new driver PIN.

- Enter the new driver PIN for a second time in the CONFIRM field (8) using the buttons (7).

If the entry matches the new driver PIN previously entered, the system will accept the new driver PIN once the last digit has been entered. The display switches back to the ACCESS CODE menu.

Another driver PIN can be defined here.

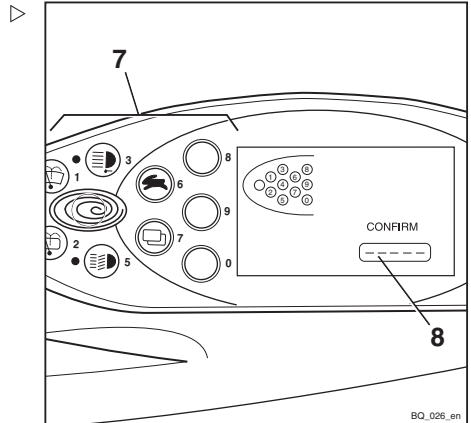

If the driver PIN entered in the CONFIRM submenu does not match the driver PIN entered previously in the NEW CODE submenu, the message INVALID will appear.

The message will then disappear after a short time. The new driver PIN can be entered in the CONFIRM submenu for further confirmation.

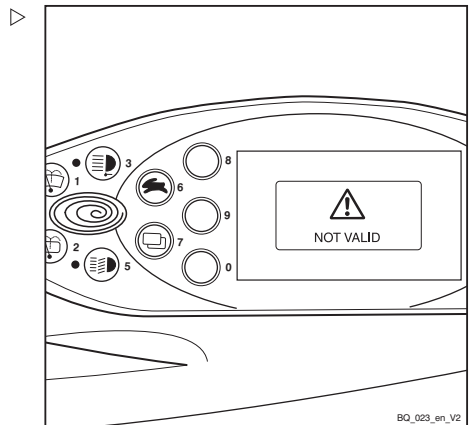

## Commissioning

After three incorrect entries, the **CODE DENIED** message appears. ▷

The display switches back to the **ACCESS CODE** menu. The desired driver PIN must be re-defined.

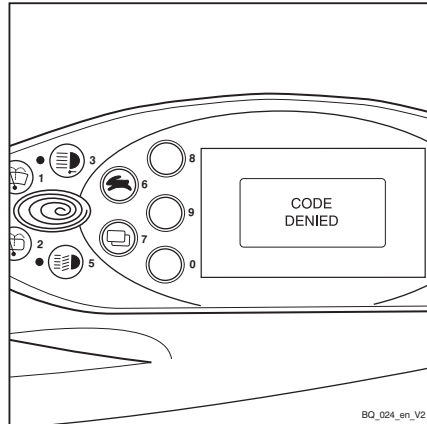

## Changing the password

It is recommended that you change the factory default password. ▷

### NOTE

*The password can only be changed when the parking brake is applied.*

- Push the drive program selection button (1) and the menu change button (2) at the same time.

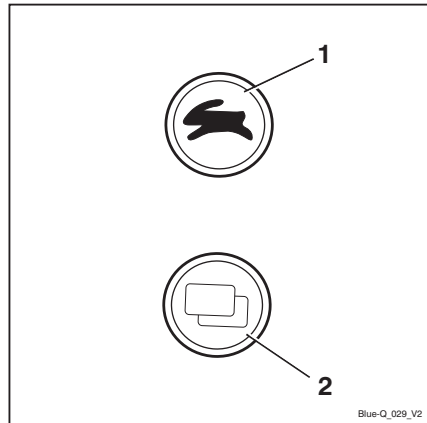

PASSWORD appears in the display.

- Enter the current password using the buttons (1).
- Confirm the entry by pressing the **ENTER** button (2).

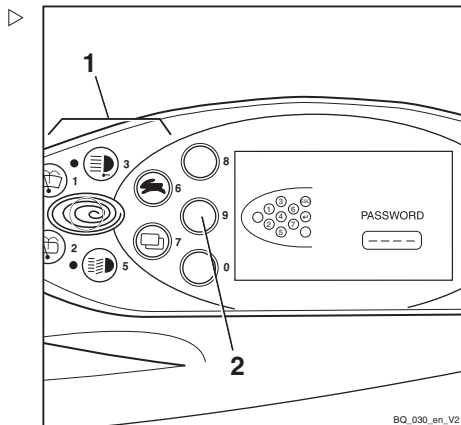

CONFIGURATION appears in the display.

- Use the drive program selection button (1) and the menu change button (3) to select the PASSWORD menu.
- Confirm your selection by pressing the **ENTER** button (2).

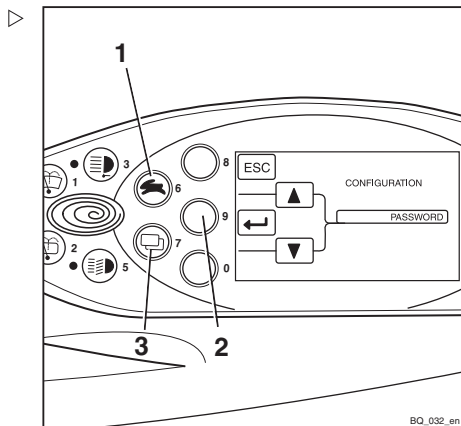

## Commissioning

PASSWORD/PASSWORD LEVEL appears in the display. ▷

- Use the drive program selection button (1) and the menu change button (4) to select the desired PASSWORD LEVEL (2).
- Confirm your selection by pressing the **ENTER** button (3).

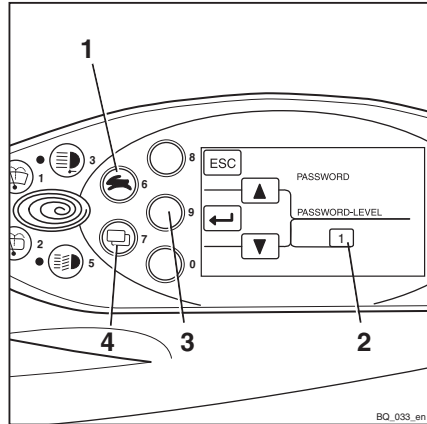

NEW CODE appears in the display. ▷

The four-digit password can be entered using the buttons (1).

### ⚠ CAUTION

Do not enter the password 1777!

If this password is entered, the configuration options for the fleet manager are restricted to driver authorisations and cannot be reset independently.

The authorisations can only be reset by the authorised service centre!

- Enter the new desired password using the buttons (1).

The digits entered are shown in plain text in the NEW CODE field (4).

- Confirm your selection by pressing the **ENTER** button (3).

In the NEW CODE field, - ? ? - appears briefly. The new password is confirmed.

- To correct the new password, push the **ESC** button (2).

The display switches back to PASS-WORD/PASSWORD LEVEL.

- Repeat the process steps from PASS-WORD/PASSWORD LEVEL.
- To exit the configuration menu, push the **ESC** button repeatedly until the standard displays appear.

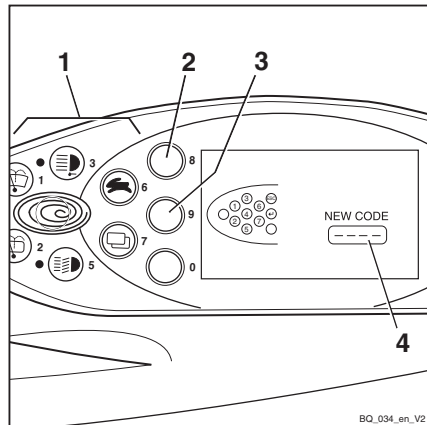

## Operating the signal horn

- Push the signal horn button (1).

The signal horn sounds.



### NOTE

*The signal horn is used to warn people against imminent danger or to announce your intention to overtake.*

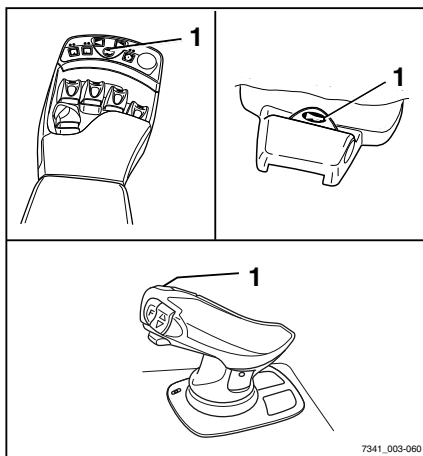

7341\_003-060

## Seat belt



### ⚠ DANGER

**Even when using an approved restraint system, there is some residual risk that the driver might be injured if the truck tips over.**

This risk of injury can be reduced through the combined use of the restraint system and the seat belt.

In addition, the seat belt protects against the consequences of rear-end collisions and falling off a ramp.

- We therefore recommend that you also use the seat belt.

### ⚠ DANGER

**Only bracket doors (variant) or the driver's cab (variant) with closed, fixed doors constitute a driver restraint system. Plastic doors (weather protection) do not constitute a restraint system!**

If you need to open or remove the doors, you must use an alternative suitable restraint system (e.g. a seat belt).

## Commissioning

## Fastening the seat belt

**⚠ DANGER****Risk to life when driving without a seat belt!**

If the truck tips over or crashes into an obstacle and the driver is not wearing the seat belt, the driver may be thrown from the truck. The driver could slide under the truck or collide with an obstacle.

There is a risk of fatal injury!

- Fasten the seat belt before every trip.
- Do not twist the seat belt when fastening it.
- Only use the seat belt to secure one person.
- Have any malfunctions repaired by the authorised service centre.

**i NOTE**

*The buckle has a buckle switch (variant). In the event of an operating error or malfunction, the message SAFETY BELT appears in the display and operating unit, see the chapter entitled "Faults".*

- Pull the seat belt (3) out of the belt retractor without jerking and fasten closely around the body over the thighs.

**i NOTE**

*Sit as far back as possible so that your back is leaning against the seat backrest. The automatic blocking mechanism permits sufficient freedom of movement on the seat.*

- Click the belt tongue (2) into buckle (1).
- Check tension of the seat belt. It should be close to the body.

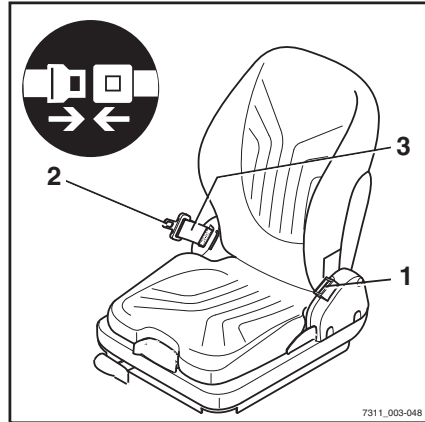



### Fastening on a steep slope

The automatic blocking mechanism prevents the belt from being extended whenever the truck is on a steep gradient. It is not possible to pull the seat belt any further out of the belt retractor.

- Move away carefully on the slope.
- Fasten the seat belt.

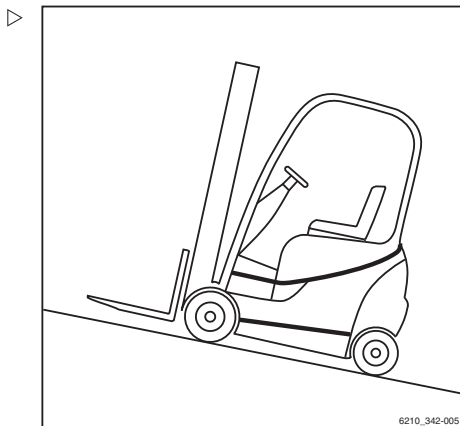

### Releasing the seat belt

- Push the red button (4) on the buckle (1).
- Manually guide the belt tongue slowly back to the retractor.

#### **i** NOTE

*Do not allow the seat belt to retract too quickly. The automatic blocking mechanism may be triggered if the belt tongue strikes the housing. It will then no longer be possible to pull the seat belt out with the usual force.*

- Using increased force, pull the seat belt around 10-15 mm out of the retractor to disengage the blocking mechanism.
- Slowly allow the seat belt to retract again.
- Protect the seat belt from dirt (for example, by covering it).

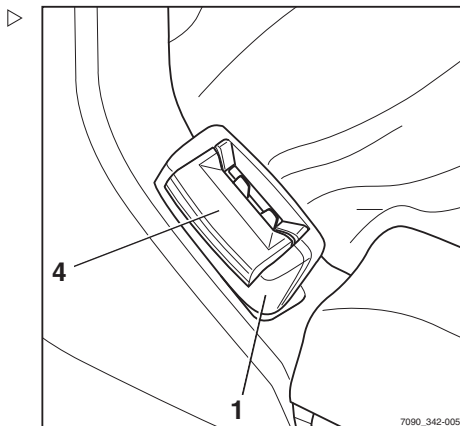

### Malfunction due to cold

- If the buckle or belt retractor is frozen, thaw them out and dry them thoroughly to prevent recurrence.

## Commissioning

### ⚠ CAUTION

The seat belt may be damaged by heat!

Do not subject the buckle or belt retractor to excessive heat when thawing.

- Do not use air warmer than 60°C when thawing.

## Using the driver's cab

### ⚠ DANGER

#### **Risk of fatal injury in the event of falling from the truck if it tips over!**

In order to prevent the driver from sliding underneath the truck and being crushed if the truck tips over, a restraint system must be in place and must be used. This will prevent the driver from falling out of the truck if it tips over. The driver's cab constitutes a driver restraint system only if the cab door is sturdy and closed. Fabric-covered cabs (variant) with doors made of plastic or canvas do not constitute a driver restraint system and offer no protection from the consequences of the truck tipping over!

- Close the cab door before operation.
- If the door is open or has been removed, use a comparably secure restraint system.
- We recommend that you always use the seat belt.

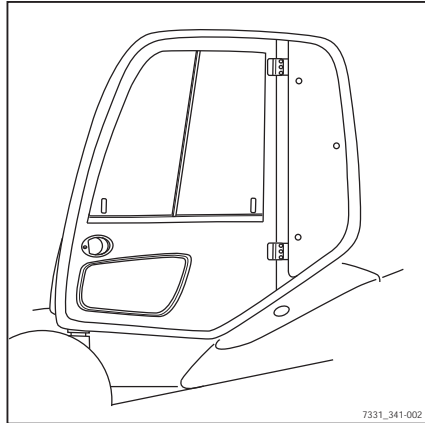

7331\_341-002

## Starting the engine

### **⚠ DANGER**

#### **Risk to health from exhaust gases!**

Exhaust gases from internal combustion engines are harmful to your health. In particular, the soot particles contained in the diesel exhaust gas can cause cancer.

When the internal combustion engine is running, there is a risk of poisoning from the CO, CH and NOx components contained in the exhaust gas.

Modern exhaust gas treatment systems (e.g. catalytic converters, particle filters or comparable systems) can clean exhaust gases in a way that reduces the health hazard and risk of poisoning when operating the truck.

- Observe the national laws and regulations when using trucks with an internal combustion engine in entirely or partially enclosed working areas.
- Always ensure sufficient ventilation.

- 
- Apply the parking brake.
  - Insert the switch key (1) into the key switch and turn to position "I" ▷

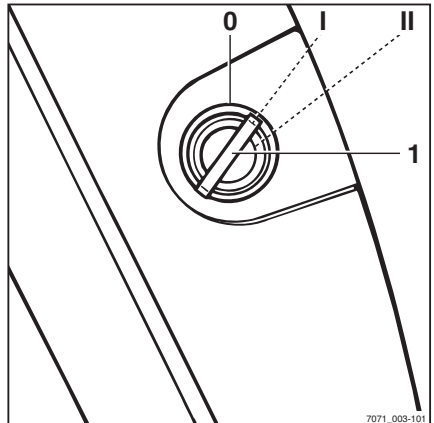

## Commissioning

The message **GLOW** flashes, indicating that the engine is being preheated. ▷

### NOTE

*Preheating can take up to 22 seconds. If the engine is already at operating temperature, preheating is not performed.*

- If the **START** message lights up on the display, turn the switch key to position "II" and hold it in this position until the engine starts
- Release the switch key as soon as the engine has started.

If the engine does not start after 20 seconds, stop the starting procedure and repeat after one minute.

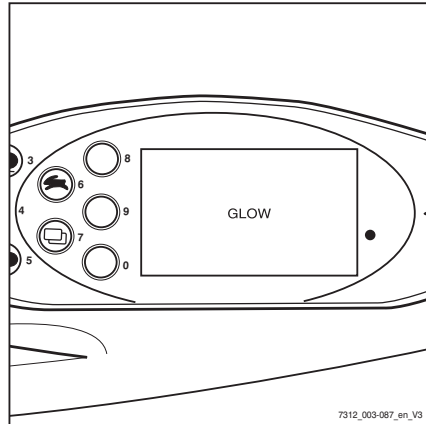

7312\_003-087\_en\_V3

### CAUTION

Risk of engine damage!

If the **OIL PRESSURE** message appears on the display after starting the engine, there may be insufficient engine lubrication. Insufficient lubrication may cause engine damage.

- Stop the engine immediately.
- Check the engine oil level and top up if necessary
- If the message continues to appear, notify the authorised service centre.

- 
- Please note the information in the chapter entitled "Faults".

### NOTE

*If the engine does not start due to a discharged battery, it can be jump-started.*

## Checking the brake system for correct function

### **⚠ DANGER**

**If the brake system fails, the truck is insufficiently braked or not braked at all, so there is a risk of accident!**

- Do not commission trucks with a defective brake system.

### Checking the foot brake

- Check pedal clearance:

There must be a distance of at least 60 mm between the pressure point and the pedal stop.

- Accelerate the truck without a load in a clear area; see "Driving" chapter.
- Press the brake pedal (1) firmly.

The truck must decelerate noticeably.

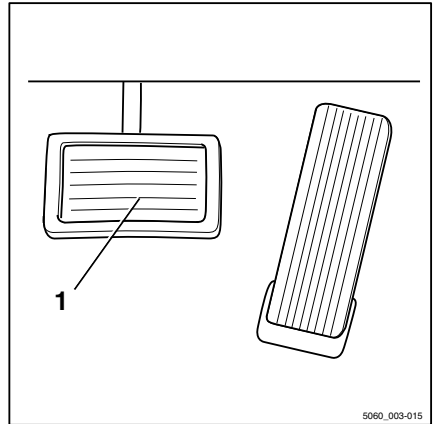

5060\_003-015

### Checking the parking brake

### **⚠ DANGER**

**If the truck rolls away, there is a risk of being run over and therefore a danger to life!**

- The truck must not be parked on a slope.
- In emergencies, secure with wedges on the side facing downhill.
- Only leave the truck when the parking brake is applied.

- Check the function of the parking brake at walking speed or on a steep gradient by applying the parking brake.

The truck must remain stationary on the gradient with the parking brake applied. If the truck rolls in spite of an actuated parking brake, contact your service centre.

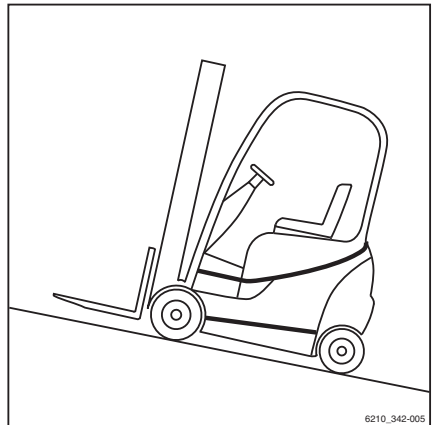

6210\_342-005

## Commissioning

### Checking the steering system for correct function

#### **⚠ DANGER**

If the hydraulics fail, there is a risk of accident as the steering characteristics have changed.

- Do not operate the truck if it has a defective steering system.
- 
- Operate steering wheel (1). The steering play while stationary must not be more than two finger widths.

#### **i NOTE**

If the truck is switched on with the steering wheel turned, the maximum driving speed is limited. Travel speed limitation is removed as soon as the steering wheel is moved out of a cornering position into the straight-ahead position. This requires a change in steering angle of about half a revolution.

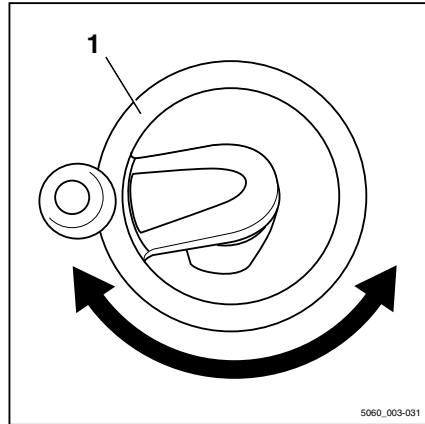

### Checking the emergency off function

#### **i NOTE**

Only trucks with a joystick 4Plus (variant) have an emergency off switch.

#### **⚠ WARNING**

No electric braking assistance is available when the emergency off switch is actuated!

Actuating the emergency off switch will de-energise the drive unit. The truck will not be held on a slope by the electric brake.

- Only use the emergency off switch in the event of a fire risk, to carry out function checking or in order to park the truck safely.
- Brake the truck by depressing the brake pedal.

**⚠ CAUTION**

There is no power steering when the emergency off switch is actuated!

The truck is equipped with a hydraulic power steering system. When the emergency off switch is actuated, the hydraulic system is completely shut down. Steering forces are increased by the remaining emergency steering function

- Only use the emergency off switch in the event of a fire risk, to carry out function checking or in order to park the truck safely.
  - Steer with a higher level of force.
- 
- Slowly drive the truck forwards.
  - Press the emergency off switch (1).

The truck will coast

- Brake the truck to a standstill by actuating the brake pedal.
- Pull out the emergency off switch (1).

The knob is unlocked and pops out. The truck performs an internal self-test and is then ready for operation again.

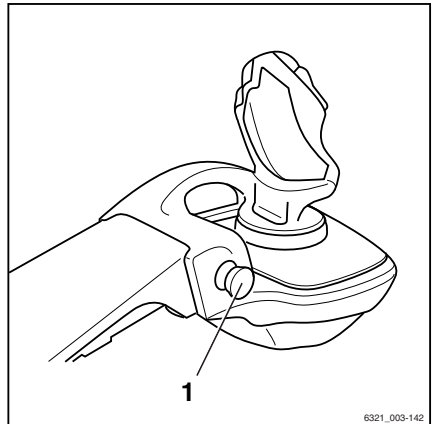

6321\_003-142

## Zero adjustment of the load measurement (variant)

### **i** NOTE

*A zero adjustment must be carried out in order to guarantee the accuracy of the load measurement (variant) at all times. Zero adjustment is required*

- *as part of daily commissioning*
- *after changing the fork arms*
- *after fitting or changing attachments.*

## Commissioning

**i** NOTE

*Accurate zero adjustment is only possible if the fork is not carrying a load. Do not take up a load yet.*

**i** NOTE

*Accurate zero adjustment is only possible within the first lifting stage of the lift mast. When carrying out the zero adjustment, do not raise the fork more than 800 mm above the ground.*

**i** NOTE

*Operation of the lifting system depends on which operating devices the truck is fitted with; see → Chapter "Lifting system operating devices", P. 5-137.*

- Set lift mast to vertical.
- Raise the fork to a height of 300–800 mm.
- Keep button (1) for the "zero adjustment" pressed for at least four seconds; the "zero adjustment" (2) symbol will appear in the display.

**i** NOTE

*During the following process, the fork carriage must be lowered slightly and then stopped abruptly. While doing so, the fork must not touch the ground, otherwise the zero adjustment will not be accurate. To stop the lowering procedure quickly, release the operating device for lowering so that it jumps into the zero position.*

- Lower the fork carriage slightly and release the operating device.

When the zero adjustment has been carried out correctly, the value "0 kg" appears in the operating unit display.

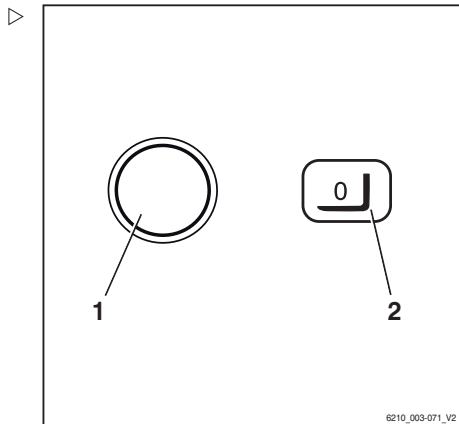



## Checking the vertical lift mast position (variant) for correct function

### NOTE

*The function check of the lift mast vertical position (variant) must be carried out every time a truck is commissioned.*

- Actuate function key (1) to switch on the comfort feature "lift mast vertical position".

Function display (2) must appear in the display.

- Tilt the lift mast backwards.

The lift mast must tilt back fully and move gently as far as the end stop.

- Tilt the lift mast forward.

The lift mast must tilt forwards and stop in the vertical position.

- Release the operating device to tilt and actuate again.

The lift mast must tilt forwards fully and move gently as far as the end stop.

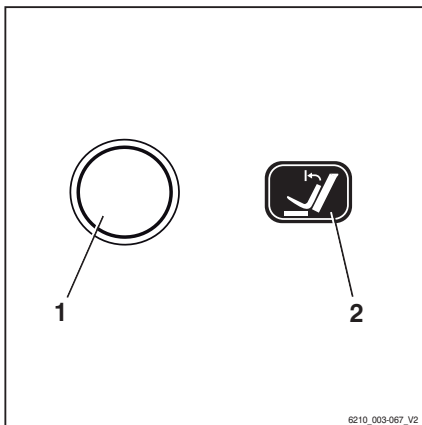

## Driving

# Driving

## Safety regulations when driving

### Driving conduct

The driver must follow the public rules of the road when driving in company traffic.

The speed must be appropriate to the local conditions.

For example, the driver must drive slowly around corners, in tight passageways, when driving through swing-doors, at blind spots, or on uneven surfaces.

The driver must always maintain a safe braking distance from vehicles and persons in front, and must always have the truck under control. Stopping suddenly, turning quickly and overtaking at dangerous or blind spots must be avoided.

– Initial driving practice must be carried out in an empty space or on a clear roadway.

The following are forbidden during driving:

- Allowing arms and legs to hang outside the truck
- Leaning the body over the outer contour of the truck
- Climbing out of the truck
- Moving the driver's seat
- Adjusting the steering column
- Releasing the seat belt
- Disabling the restraint system
- Raising the load higher than 300 mm above the ground (with the exception of manoeuvring processes during the placement into stock/removal from stock of loads)
- Using electronic devices, for example radios, mobile phones etc.

**⚠ WARNING**

The use of multimedia and communication equipment as well as playing these devices at an excessive volume during travel or when handling loads can affect the operator's attention. There is a risk of accident!

- Do not use devices during travel or when handling loads.
- Set the volume so that warning signals can still be heard.

**⚠ WARNING**

In areas where use of mobile phones is prohibited, use of a mobile phone or radio telephone is not permitted.

- Switch off the devices.

**Visibility when driving**

The driver must look in the drive direction and have a sufficient view of the driving lane.

Particularly for reverse travel, the driver must be sure that the driving lane is clear.

When transporting goods that impair visibility, the driver must drive the truck in reverse.

If this is not possible, a second person acting as a guide must walk in front of the truck.

In this case the driver must only move at walking pace and with extra care. The truck must be stopped immediately if eye contact with the guide is lost.

Rear-view mirrors are only to be used for observing the road area behind the truck and not for reverse travel. If visual aids (mirror, monitor) are necessary to achieve sufficient visibility, it is necessary to practise using them. For reverse travel using visual aids, extra care should be taken.

When using attachments, special conditions apply; see the chapter entitled "Fitting attachments".

Any glass (variant, e.g. windscreen) and mirrors must always be clean and free of ice.

## Driving

## Roadways

## Dimensions of roadways and aisle widths

The following dimensions and aisle width requirements apply under the specified conditions to ensure safe manoeuvring. In each case, it must be checked whether a larger aisle width is necessary, e.g. in the case of different load dimensions.

Within the EU, the 89/654/EEC directive (minimum health and safety requirements for the workplace) must be observed. The respective national guidelines apply for areas outside of the EU.

The required aisle widths depend on the dimensions of the load.

For pallets, these are:

Model	Type	Aisle width [mm]	
		with pallet 1000 x 1200 crosswise	with pallet 800 x 1200 lengthwise
RX70-60 (LSP 600)	7341	4907	5107
RX70-70 (LSP 600)	7342	4987	5187
RX70-80 (LSP 600)	7343	5056	5256
RX70-80 (LSP 900)	7344	5185	5385

The truck may only be used on roadways that do not have excessively sharp bends, excessively steep gradients or excessively narrow or low entrances.

## Driving on gradients

 **WARNING**

Driving up and down longer gradients may cause the drive unit to overheat and switch off.

Driving up and down longer gradients is not permitted due to the minimum specified braking values. The climbing capability values given below only apply to overcoming obstacles on the roadway and to short differences in level, e.g. ramps.

The truck may be driven on the following upwards or downwards gradients:

Model	Type	Maximum gradient [%]	
		with load	Without load
RX70-60 (LSP 600)	7341	33	32
RX70-70 (LSP 600)	7342	27	30
RX70-80 (LSP 600)	7343	24	30
RX70-80 (LSP 900)	7344	21	29

LSP = load centre of gravity

The upwards and downwards slopes may not exceed the gradient listed above and should have a rough surface.

Smooth and gradual transitions at the top and bottom of the gradient should prevent the load from falling to the ground or the truck being damaged.

### Warning in case components project beyond the truck contour

Trucks are often required to drive through very narrow or very low spaces such as aisles or containers. The trucks are dimensioned for this purpose. However, movable parts may project beyond the truck contour and be damaged or torn off. Examples of such components include:

- A folding roof panel in the driver's cab
- Cab doors
- Folding LPG cylinders

### Condition of the roadways

Roadways must be sufficiently firm, level and free from dirt and fallen objects.

Drainage channels, level crossings and similar objects must be compensated for, and if necessary, ramps must be provided so that trucks can drive over these with as few bumps as possible.

## Driving

Ensure sufficient load capacity of manholes, drain covers and the like.

There must be sufficient distance between the highest points of the truck or the load and the fixed elements of the surrounding area. The height is based on the overall height of the lift mast and the dimensions of the load; see the chapter entitled "Technical data".

### Rules for roadways and the working area

It is only permitted to drive on routes authorised for traffic by the operating company or its representatives. Traffic routes must be free of obstacles. The load may only be set down and stored in the designated locations. The operating company and its representatives must ensure that unauthorised third parties do not enter the working area.



#### NOTE

*Please note the definition of "operating company" in the sense of responsible persons!*

### Hazard areas

Hazardous areas on the roadways must be marked by standard traffic signs or, if necessary, by additional warning signs.

### Setting the drive programme

The driving and braking characteristics of the drive can be set on the display and operating unit.

- Push the drive programme button (1) repeatedly until the number of the required drive programme appears on the display (2).

Drive programmes 1–5 are available.

Essentially, the higher the number of the drive programme, the greater the driving dynamics.

The following drive programmes are available:

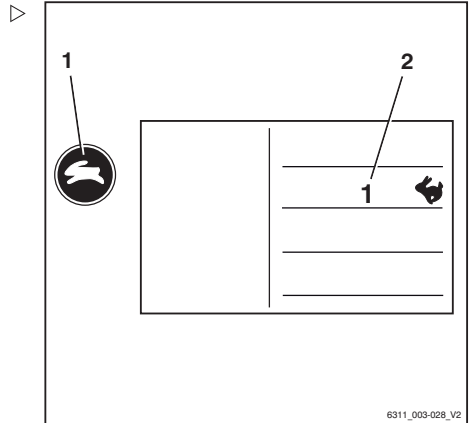

Drive programme	1	2	3	4	5
Speed (km/h)	20	20	20	20	20
Acceleration (%) (forwards/backwards)	50	100	120	140	160
Deceleration (%) (forwards/backwards)	50	100	120	140	160
Reversing (%) (forwards/backwards)	50	100	120	140	160
Brake retardation (%) (electric brake booster)	80	90	100	100	100

### Selecting the drive direction

The desired drive direction of the truck must be selected using the drive direction switch before attempting to drive. The method of actuating the drive direction switch depends on the operating devices included in the truck's equipment.

Possible equipment variants include:

- Mini-lever
- Joystick 4Plus
- Fingertip switch
- Mini-console

**i** NOTE

*The drive direction can also be changed during travel. Your foot can remain on the accelerator pedal while doing so. The truck is*

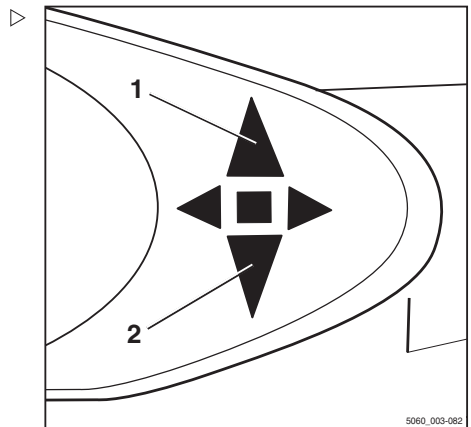

## Driving

*then decelerated and accelerated again in the opposite direction (reversing).*

The indicator for the selected drive direction ("forwards" (1) or "reverse" (2)) lights up on the display and operating unit.

### Neutral position

If the truck is stopped for an extended period, select the neutral position to prevent the truck from suddenly starting if the accelerator pedal is inadvertently pressed.

- Briefly select the drive direction switch for the direction opposite to the current direction.

The drive direction indicator on the display and operating unit goes out.



### NOTE

*When the seat is vacated, the drive direction switch is set to "Neutral". To drive, the drive direction switch must be actuated again.*

### Actuating the drive direction switch, mini-lever version

- For the "forwards" drive direction, push the cross lever (1) forwards
- For the "backwards" drive direction, push the cross lever backwards

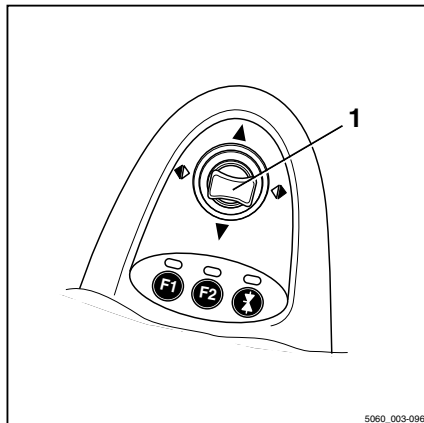

5060\_003-096



### Actuating the vertical rocker switch for the "drive direction", joystick 4Plus version

- For the "forwards" drive direction, push the vertical rocker button for the "drive direction"(1) upwards (A).
- For the "reverse" drive direction, push the vertical rocker button for the "drive direction"(1) downwards (B).

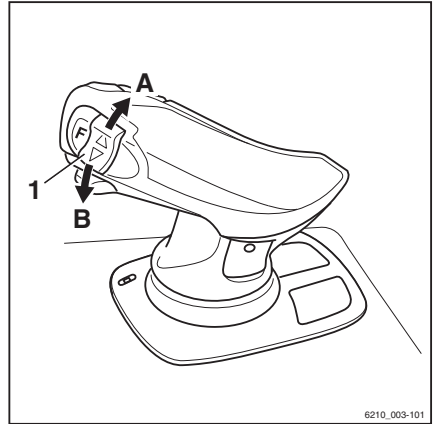

### Actuating the drive direction switch, fingertip version

- For the "forwards" drive direction, push the drive direction switch (1) forwards
- For the "backwards" drive direction, push the drive direction switch backwards



## Driving

### Actuating the drive direction switch, mini-console version

- For the "forwards" drive direction, push the drive direction switch (1) forwards.
- For the "backwards" drive direction, push the drive direction switch to the rear.

#### NOTE

*Alternatively, the drive direction can also be selected using the drive direction switches on the operating devices.*

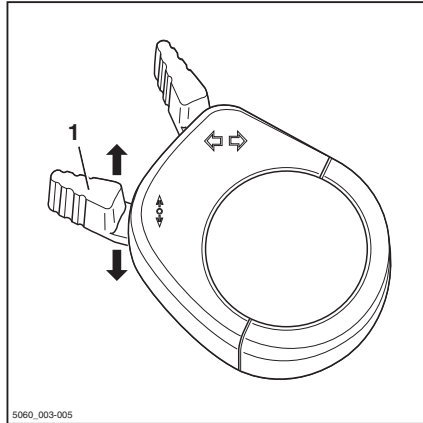

### Starting to drive

#### DANGER

**Being trapped under a rolling or tipping truck could cause fatal injuries.**

- Sit down on the driver's seat.
- Fasten the seat belt.
- Activate the available restraint systems.

Observe the information in the chapter entitled Safety regulations when driving.

The driver's seat is equipped with a seat switch. This checks whether the driver's seat is occupied. If it is not occupied or in the case of malfunction of the seat switch, the truck cannot be moved and all lifting functions are locked. In this situation, the message SEAT SWITCH appears in the operating unit display.

- Lift the fork carriage until the necessary ground clearance is achieved.
- Tilt the lift mast backwards.
- Release the parking brake.
- Select the desired drive direction.

The indicator for the selected drive direction ("forwards" (1) or "backwards" (2)) lights up on the display and operating unit.

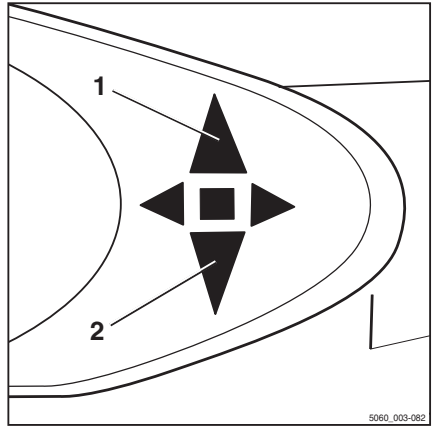

**i NOTE**

*Depending on the equipment, an acoustic signal (variant) may sound a warning during reverse travel, the warning light (variant) may light up or the hazard warning system (variant) may flash.*

- Press the accelerator pedal (3).

The truck will travel in the selected drive direction. The speed is controlled by the accelerator pedal position. When the accelerator pedal is released, the truck decelerates.

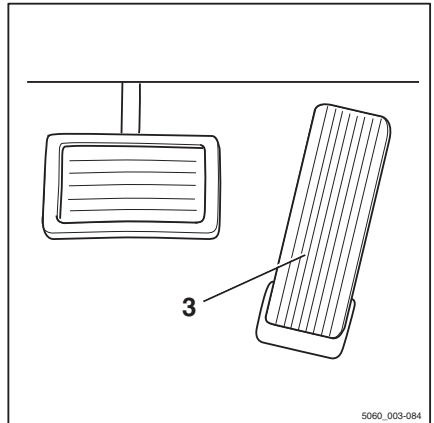

**i NOTE**

*The truck can briefly be stopped on upward or downward gradients without actuating the parking brake (electric brake). The truck begins to creep downhill slowly.*

**⚠ DANGER**

**Risk of accident due to brake failure!**

The electric brake only functions while the key switch is switched on, the emergency off switch (variant) has not been actuated and the parking brake is released.

- Use the brake pedal if the electrical brake malfunctions
- Do not leave the truck without actuating the parking brake!

**Changing the drive direction**

- Remove foot from accelerator pedal.
- Select the desired drive direction.
- Press the accelerator pedal.

The truck will travel in the selected drive direction.

## Driving

 NOTE

*The drive direction can also be changed during travel. Your foot can remain on the accelerator pedal. The truck decelerates and is then accelerated again in the opposite direction (reversing).*

 NOTE

*In the event of an electrical fault with the accelerator the drive unit is shut down. The electrical brake (service brake) causes the truck to decelerate. The truck cannot be driven again until the accelerator pedal has been released and then actuated again, provided the electrical fault has been corrected. If the truck still won't operate, park it securely and contact your service centre.*

## Starting drive mode, dual-pedal version (variant)

 DANGER

**Being trapped under a rolling or tipping truck could cause fatal injuries.**

- Sit down on the driver's seat.
- Fasten the seat belt.
- Activate the available restraint systems.

Observe the information in the chapter entitled Safety regulations when driving.

The driver's seat is equipped with a seat switch. This checks whether the driver's seat is occupied. If it is not occupied or in the case of malfunction of the seat switch, the truck cannot be moved and all lifting functions are locked. In this situation, the message SEAT SWITCH appears in the operating unit display.

- Lift the fork carriage until the necessary ground clearance is achieved.
- Tilt the lift mast backwards.
- Release the parking brake.

- Press the right accelerator pedal (1) to drive "forwards" and press the left accelerator pedal (2) to drive "backwards".

**i NOTE**

*In the dual pedal version, any drive direction switches on the operating devices have no effect.*

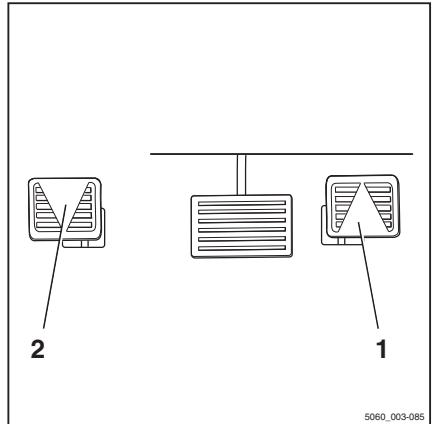

The indicator for the selected drive direction ("forwards" (3) or "backwards" (4)) lights up on the display and operating unit.

**i NOTE**

*Depending on the equipment, an acoustic signal (variant) may sound a warning during reverse travel, the warning light (variant) may light up or the hazard warning system (variant) may flash.*

The truck will travel in the selected drive direction. The speed is controlled by the accelerator pedal position. When the accelerator pedal is released, the truck decelerates.

**i NOTE**

*The truck can briefly be stopped on upward or downward gradients without actuating the parking brake (electric brake). The truck begins to creep downhill slowly.*

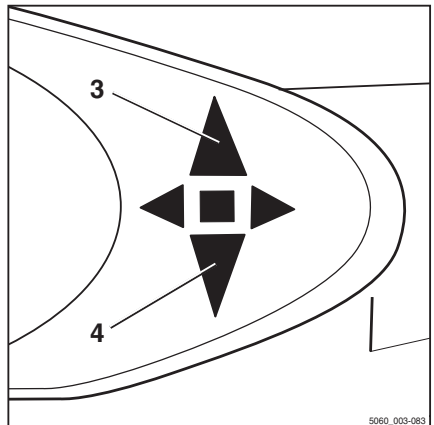

## Driving

 **DANGER****Risk of accident!**

The electric brake only functions while the key switch is switched on, the emergency off switch (variant) has not been actuated and the parking brake is released.

- Use the brake pedal if the electric brake malfunctions.
- Do not leave the truck without actuating the parking brake!

---

**Changing the drive direction**

- Remove foot from actuated accelerator pedal.
- Actuate the accelerator pedal for the other direction.

The truck will travel in the selected drive direction.

**NOTE**

*In the event of an electrical fault with the accelerator the drive unit is shut down. The electrical brake (service brake) causes the truck to decelerate. The truck cannot be driven again until the accelerator pedal has been released and then actuated again, provided the electrical fault has been corrected. If the truck still won't operate, park it securely and contact your service centre.*

## Operating the service brake

The electric brake converts the acceleration energy of the truck into electrical energy. This causes the truck to decelerate.

In addition, the truck can be braked using the service brake:

- Press the brake pedal (2).

In the first section of the brake pedal's travel, only the regenerative braking takes effect. As the pedal is depressed further, the service brake is also activated and acts on the drive wheels.

### **⚠ DANGER**

#### **Risk of accident!**

If the service brake fails, the truck cannot brake sufficiently.

- Bring the truck to a standstill by applying the parking brake.
- Do not operate the truck again until the service brake has been repaired.

### **⚠ DANGER**

#### **Risk of tipping and risk of slipping!**

The braking distance of the truck depends on the weather conditions and the level of contamination on the roadway. The braking distance increases with the square of the speed. There is a danger that the truck could slip or overturn.

- Adapt your driving and braking style to suit the weather conditions and the level of contamination on the roadway.
  - Always choose a driving speed that will provide a sufficient stopping distance.
- 
- Brake the truck by releasing the accelerator pedal (1).
  - If the braking effect is inadequate, brake using the service brake (2) as well.

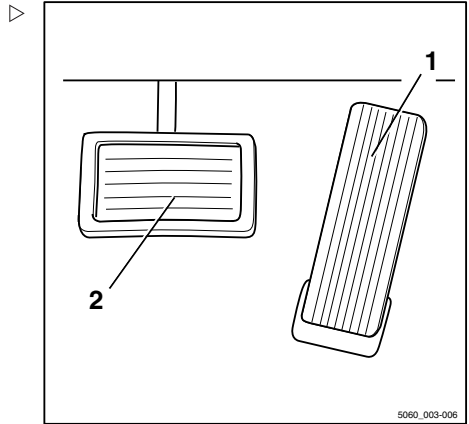

## Driving

### Zero braking (variant)

#### DANGER

##### **Risk of accident!**

Trucks with zero braking (variant) are not braked when the accelerator pedal is released.

- Bring the truck to a standstill by actuating the brake pedal.

If your truck features the zero braking equipment variant, the electric brake function is disabled. Taking your foot off the accelerator pedal does not brake the truck.

In this case, the truck can only be slowed by applying the service brake via the brake pedal.

### Parking brake

The truck is equipped with a mechanical parking brake.

### Actuating the mechanical parking brake

#### DANGER

**There is a risk of being run over if the truck rolls away, and therefore a danger to life.**

- The truck must not be parked on a slope.
- In emergencies, secure with wedges on the side facing downhill.
- Only leave the truck when the parking brake is applied.

#### NOTE

*Once the parking brake is released, the previously selected drive direction is retained and is shown on the drive direction indicator.*

#### NOTE

*If you operate the accelerator pedal while the parking brake is applied and a drive direction is selected, the message PARKING BRAKE appears in the display.*



### Apply the parking brake

- Pull the parking brake lever (1) down fully and release.

The parking brake lever swivels back half the distance into the middle position automatically.

The parking brake is engaged and the wheels are blocked. Driving is no longer possible. The drive direction indicator (2) on the display and operating unit goes out.

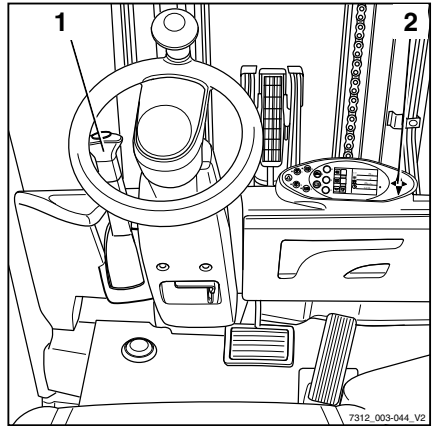

### Releasing the parking brake

- Pull the parking brake lever (1) down fully out of the middle position.
- In the lower lever position, pull out the lever knob and then guide the parking brake lever up fully.

**i** NOTE

*The parking brake lever swivels to the upper position automatically by means of spring force and should be guided only lightly by hand. If the adjustment is stiff, notify the authorised service centre.*

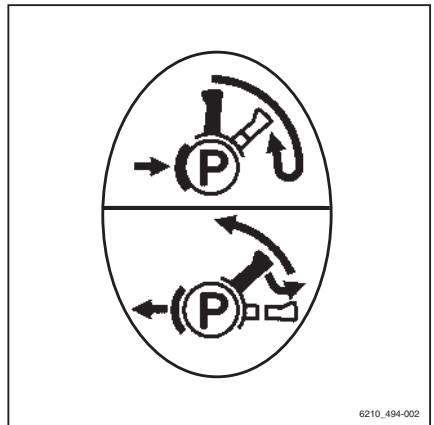

## Driving

## Steering

**⚠ DANGER**

If the hydraulics fail, there is a risk of accident as the steering characteristics have changed.

- Do not operate the truck if it has a defective steering system.
- Steer the truck by turning the steering wheel (1) accordingly.

Turning the steering wheel in the direction of arrow (A) steers the truck in drive direction (A).

Turning the steering wheel in the direction of arrow (B) steers the truck in drive direction (B).

For turning radius information, see ⇒ Chapter "Technical data", P. 351.

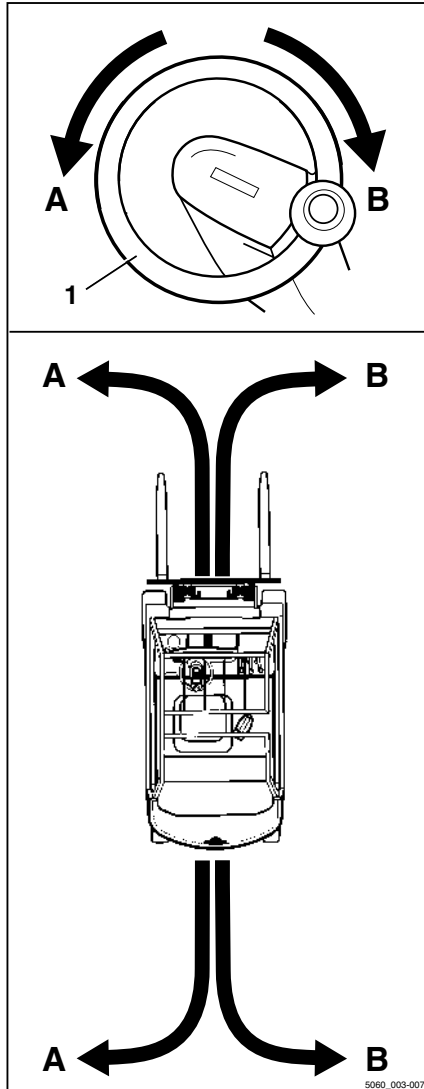

## Reducing speed when turning (Curve Speed Control)

This function reduces the speed of the truck as the steering angle increases, regardless of the amount to which the accelerator has been actuated. If the steering angle is reduced again upon exiting the curve, the truck accelerates in line with how far the accelerator is depressed.

However, the function does not release the driver from the duty to approach a curve at a speed according to the following factors:

- The carried load
- The roadway conditions
- The radius of the curve

### **⚠ DANGER**

**The Curve Speed Control function cannot override the physical limits of stability. Despite this function, there still is a risk of tipping!**

- Before using this function, familiarise yourself with the change to the driving and steering characteristics of the truck.

### **⚠ DANGER**

**Increased risk of tipping if the Curve Speed Control function is disabled! If the controller fails while the truck is in motion or if the controller is disabled, the truck will no longer automatically brake when steering.**

- Do not turn off the key switch while driving.
- Actuate the emergency stop switch only in emergencies.
- Always adapt your driving style to the conditions.

Despite the Curve Speed Control function, the truck may overturn in extreme cases within the following situations:

- Cornering too fast on uneven or inclined roadways.
- Turning the steering wheel sharply while driving.
- Cornering with an inadequately secured load.
- Cornering too fast on a smooth or wet roadway.

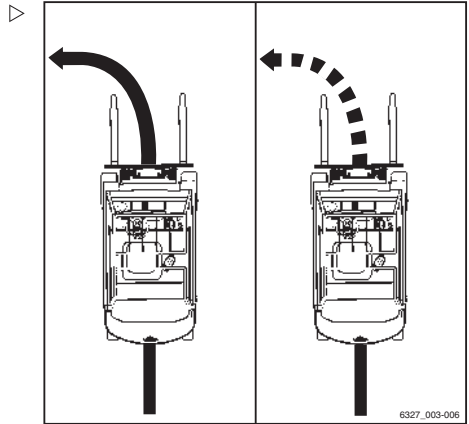

## Driving

### Reducing speed with a raised load (variant)

This function (variant) reduces the speed of the truck with a raised load.

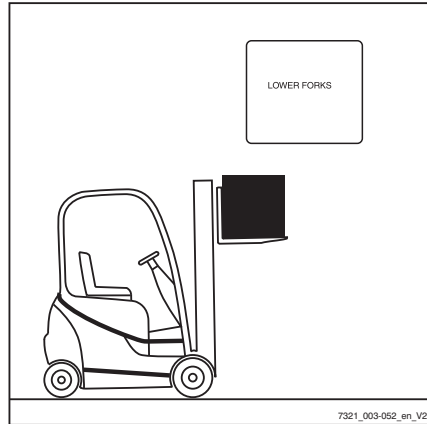

### Automatic shut-off of the internal combustion engine (variant)

The truck is equipped with an automatic shut-off function that shuts off the internal combustion engine when certain conditions apply simultaneously and after a preset waiting time has elapsed.

The message **CUTOUT MODE** appears in the display.

#### Conditions that apply simultaneously:

- The truck is stationary.
- The parking brake is applied.
- The driver's seat is not occupied.
- Particle filter regeneration is not in progress.
- There are no consumers switched on that require a significant amount of energy, such as the air conditioning.

The waiting time only starts when all conditions apply simultaneously. If one of the conditions is no longer fulfilled, the waiting time stops and is restored to the preset value.

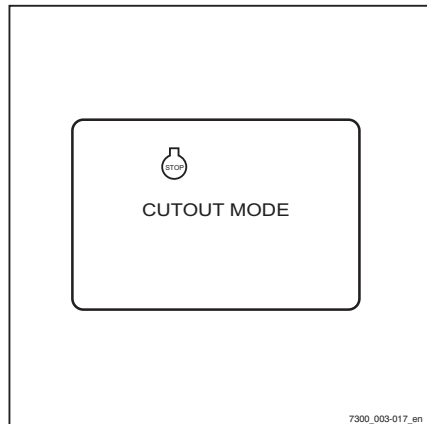

#### NOTE

*The waiting time is set to 120 seconds at the factory, but can be changed at a later date.*

- *Contact the authorised service centre.*

## Lifting

### Lifting system variants

The movement of the fork carriage and the lift mast heavily depends on the following equipment:

- The lift mast with which the truck is equipped, see ⇒ Chapter "Types of lift mast", P. 5-134
- The operating device with which the hydraulic functions are controlled, see ⇒ Chapter "Lifting system operating devices", P. 5-137

Regardless of the equipment variants of the truck, the basic specifications and procedures must be complied with, see ⇒ Chapter "Safety regulations when handling loads", P. 5-150.

### Automatic lift cut out (variant)

#### Description:

The automatic lift cut out (variant) means that the load cannot be lifted above a preset height. This function uses a sensor that is welded on at the factory at the required lift mast limit height. Once attached, the height cannot be easily changed.

#### Application:

- If the ceiling of the building is lower than the maximum lift height of the truck, this variant can prevent the lift mast from accidentally hitting the ceiling, which can result in damage.
- If the truck is frequently used at a particular height, the work is simplified by the automatic lift cut out at this height.



#### NOTE

*If a load is lifted very quickly, the fork carriage and load are moved approximately 15 cm above the position of the sensor due to inertia. This deviation is already taken into consideration at the factory when determining the position of the sensor.*

## Lifting

**Overriding and reactivating the automatic lift cut out**

If a load needs to be lifted to the truck's maximum lift height and the automatic lift cut out function is not required, it is possible to override the lift cut out. It is automatically reactivated when the truck is switched off and back on again.

**To override the automatic lift cut out:**

- Press the "F1"(1) button on the display operating unit. The automatic lift cut out is now overridden and a load can be lifted to the truck's maximum lift height.

**To switch the automatic lift cut out back on:**

- Press the "F1"(1) button again.

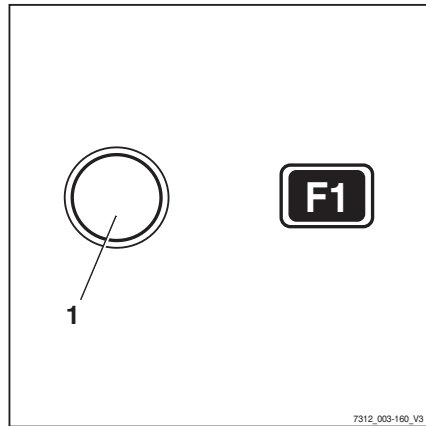

7312\_003-160\_V3

**Lift mast vertical position (variant)****Description**

If the truck is equipped with the "lift mast vertical position" comfort feature (variant), the driver can put goods, such as paper rolls, down vertically with precision and thus avoid damage when unloading. The tilt cylinders run into the end stops gently to prevent hard vibrations and impacts. Oscillating motions of the truck are minimised, thus increasing work safety. The lift mast vertical position reduces wear on various components and therefore reduces maintenance costs.

**⚠ CAUTION**

Risk of damage to property due to the lift mast colliding with racks or other objects!

- Before using the "lift mast vertical position" comfort feature, position the truck at a sufficient distance from racks and other objects.

The "lift mast vertical position" comfort feature consists of the following individual functions:

- Display of the "lift mast vertical position"
- Automatic approach towards the "lift mast vertical position"
- Gentle running-in to the end stops

**Display of the "lift mast vertical position"** ▷

The driver can see the mast tilt on the display and operating unit screen. The bar in the display shows the current mast tilt relative to the "lift mast vertical position". The arrow above the bar marks the vertical position of the lift mast.

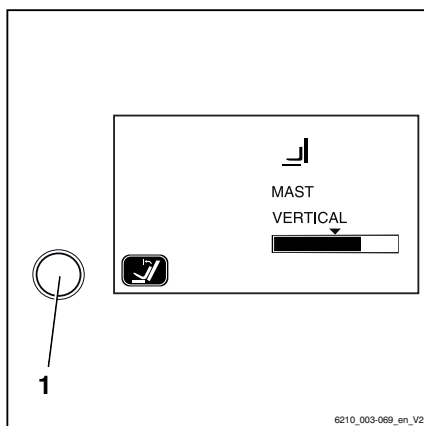

## Lifting

**Automatic approach towards the "lift mast vertical position"**

- Switch on the "lift mast vertical position" comfort feature via the button (1) on the display and operating unit.
- Tilt the lift mast forwards using the corresponding operating device. The lift mast stops automatically as soon as the pre-selected setting is reached for the "lift mast vertical position".

If the comfort feature is switched off, the lift mast tilts forwards past the "lift mast vertical position" without stopping.

If the lift mast is tilted backwards, it moves past the "lift mast vertical position" without stopping, regardless of whether the comfort feature is switched on or not.

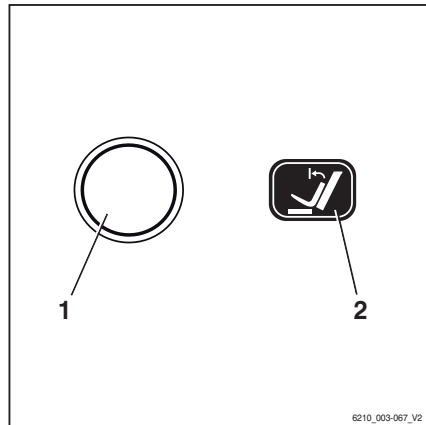
**Gentle running-in to the end stops**

The lift mast is braked gently at the end of the tilt range. This prevents the lift mast from stopping harshly in the end position and reduces severe oscillating motions of the truck.

**Tilting the lift mast forwards with the "lift mast vertical position"**

- Actuate the button (1) to switch on the "lift mast vertical position" comfort feature; the function display (2) in the display shows the activated status.
- Tilt the lift mast forwards.

** NOTE**

*The way in which the lifting system is operated depends on the operating devices included in the truck's equipment; see the chapter entitled "Lifting system operating devices".*

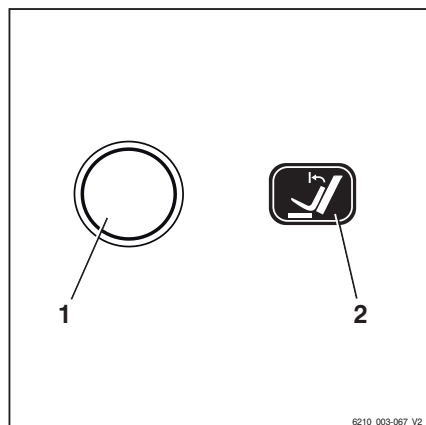



The lift mast is tilted forwards and stops as soon as the vertical position is reached. The arrow above the bar shown on the screen of the display and operating unit represents the "lift mast vertical position".

Tilt the lift mast forwards beyond the vertical position:

- Release the operating device for tilting and actuate again.

The lift mast is tilted beyond the vertical position up to the end stop. The current mast tilt is shown in the display and operating unit.

- To deactivate the "lift mast vertical position", actuate the button (1) again.

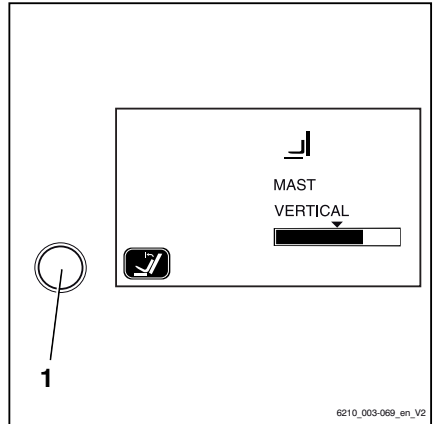

### Tilting the lift mast backwards with the "lift mast vertical position"

- Tilt the lift mast backwards.

The lift mast is tilted backwards without stopping in the vertical position.

### Possible restrictions on the "lift mast vertical position"

In some circumstances, the lift mast cannot move exactly into the preset vertical position. Possible causes include:

- Uneven ground
- Bent fork
- Bent attachment
- Worn tyres
- Severely deformed lift mast

The vertical position can be corrected by tilting the lift mast using the relevant operating device. If the vertical position has to be corrected frequently, the "lift mast vertical position" should be calibrated.

## Lifting

**Calibrating the "lift mast vertical position"** ▷

- Set the lift mast to the required position.
- Press and hold the button (1) for the "lift mast vertical position" for at least five seconds.

The message "? VERTICAL POSITION" will appear on the display.

**Storing the mast position:**

- Press the drive program button (3).

The current mast position is stored.

**Cancelling calibration:**

- Press the menu change button (2).

The calibration is cancelled.

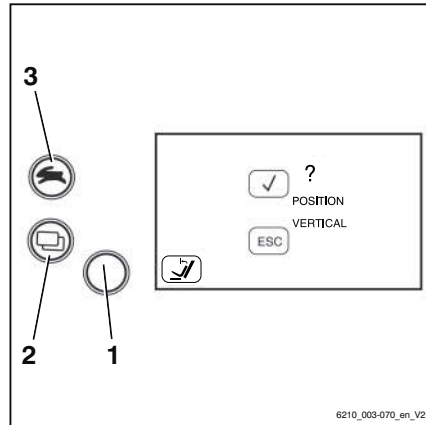
**Types of lift mast**

One of the following lift masts may be installed in the truck:

**Telescopic mast** ▷

During lifting, the lift mast rises over the outer lift cylinders, bringing the fork carriage with it via the chains (fork carriage rises twice as fast as the inner lift mast). The top edge (1) of the inner lift mast can therefore be higher than the fork carriage.

**⚠ DANGER****Risk of accident due to collision of the lift mast or load with low ceilings or entrances.**

- Note that the inner lift mast or load may be higher than the fork carriage.
- Note the heights of ceilings and entrances.

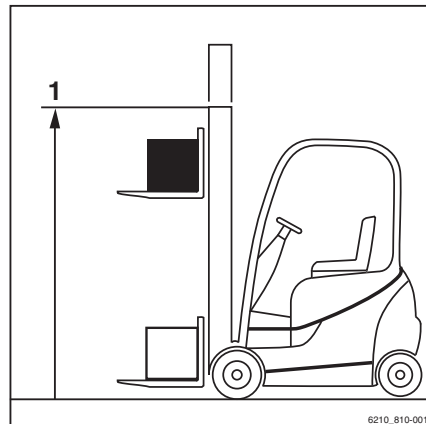

### Triplex lift mast (variant)

During lifting, the inner lift cylinder moves up to free lift (3), and then the outer lift cylinders raise the inner lift mast up to the max. height (2).

#### **⚠ DANGER**

**Risk of accident due to collision of the lift mast or load with low ceilings or entrances.**

- Note that the inner lift mast or load may be higher than the fork carriage.
- Note the heights of ceilings and entrances.

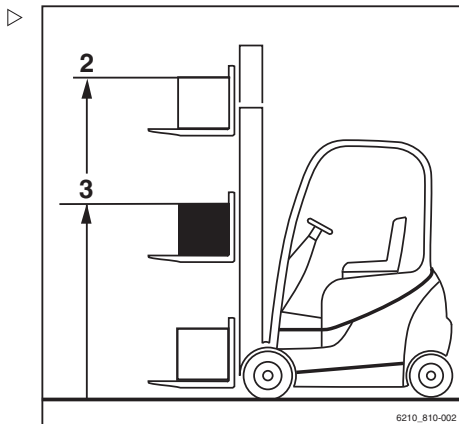

## Malfunctions during lifting mode

### Incorrect extension sequence

#### **⚠ DANGER**

#### **Risk of accidents!**

With triple masts (variant), an incorrect extension sequence may occur, i.e. the inner lift mast may extend before the free lift has finished. As a result, the overall height is exceeded and damage may occur in passageways or from low ceilings.

An incorrect extension sequence may, for instance, result from:

- The hydraulic oil temperature being too low.
  - The fork carriage becoming blocked in the inner lift mast.
  - Blocking of the free lift cylinder.
  - The chain roller becoming blocked at the free lift cylinder.
- If the hydraulic oil temperature is too low, slowly actuate the lift mast functions several times in order to raise the oil temperature.

In the event that the fork carriage is blocked in the inner lift mast, or the free lift cylinder or chain roller are blocked, the cause of the blockage must be eliminated before resuming work.

- Notify your service centre

## Lifting

**Load chains not under tension****⚠ DANGER****Danger caused by a falling load!**

- Make sure that the chain(s) does (do) not become slack when lowering the load.

Slack chains can, for instance, result from:

- Resting the fork carriage or the load on the racking.
- Fork carriage rollers becoming blocked in the lift mast due to contamination.
- If the fork carriage or the load comes to an unexpected stop, lift the fork carriage until the chains are under tension again and lower the load at another suitable location.
- If the fork carriage rollers in the lift mast become blocked due to contamination, lift the fork carriage until the chains are under tension again. Remove the contamination before resuming work.

**⚠ WARNING**

Risk of injury!

- Observe the safety regulations for working on lift masts; see → Chapter "Working at the front of the truck", P. 6-318.

**Hydraulic blocking function**

The hydraulic blocking function ensures that all the functions of the working hydraulics are disabled whenever the seat switch in the driver's seat is unloaded.

If the driver stands up from the driver's seat, the blocking function prevents the hydraulic functions that:

- Lift the load
- Lower the load
- Tilt the lift mast
- Additional functions

**Releasing the block on the hydraulics**

Proceed as follows to release the block on the hydraulics:

- Sit down on the driver's seat.

All the relevant functions of the working hydraulics will be available again.

### NOTE

*If it is not possible to release the block on the hydraulics when the load is raised because of a technical fault, the load must be lowered using the "emergency lowering" mechanism before any further action is taken. Do not operate the truck again until the fault has been rectified by the authorised service centre.*

## Lifting system operating devices

The method of operating the lifting system depends on the operating devices included in the truck's equipment.

Possible equipment variants include:

- **Double mini-lever**
  - **Triple mini-lever**
  - **Quadruple mini-lever**
  - **Joystick 4Plus**
  - **Fingertip switch**
- The following information must be observed regardless of the equipment variant:

### DANGER

**Reaching into or climbing between moving parts of the truck (e.g. lift mast, sideshifts, working equipment, load carrying devices etc.) can lead to serious injury or death and is therefore prohibited.**

- Observe the safety regulations for handling loads.
  - Only operate the lifting system from the driver's seat.
-

## Lifting

## Controlling the lifting system using a double mini-lever ▷

### **⚠ DANGER**

Reaching into or climbing between moving parts of the truck (e.g. lift mast, sideshifts, working equipment, load carrying devices etc.) can lead to serious injury or death and is therefore prohibited.

- Observe the safety regulations for handling loads.
- Operate the lifting system from the driver's seat only.

### Lifting/lowering the fork carriage

To lift the fork carriage:

- Move the "lift mast" 360° lever (1) in the direction of arrow (B).

To lower the fork carriage:

- Move the "lift mast" 360° lever (1) in the direction of arrow (A).

### Tilting the lift mast

To tilt the lift mast forwards:

- Move the "lift mast" 360° lever (1) in the direction of arrow (C).

To tilt the lift mast backwards:

- Move the "lift mast" 360° lever (1) in the direction of arrow (D).

### **i** NOTE

The symbols on the 360° lever show the direction of movement of the lift mast and the fork carriage when the 360° lever is moved.

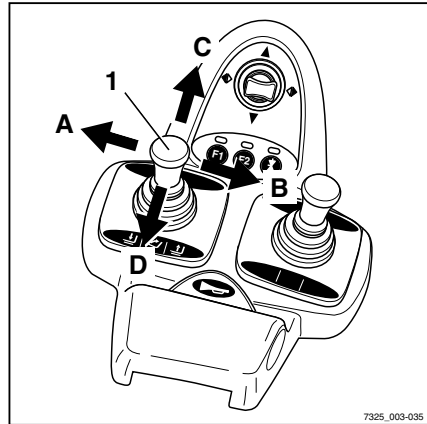

7325\_003-035

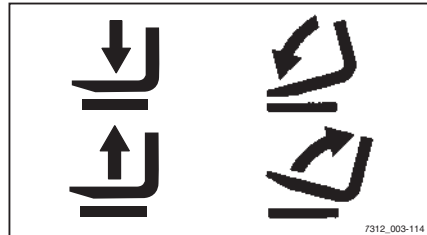

7312\_003-114

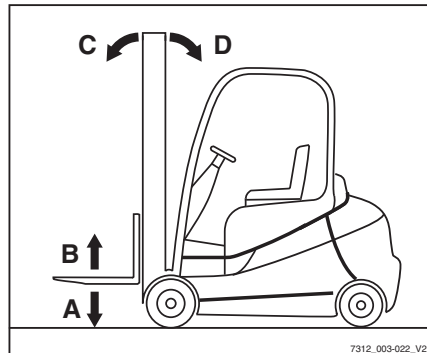

7312\_003-022\_V2

## Controlling the lifting system using a triple mini-lever ▷

### **⚠ DANGER**

Reaching into or climbing between moving parts of the truck (e.g. lift mast, sideshifts, working equipment, load carrying devices etc.) can lead to serious injury or death and is therefore prohibited.

- Observe the safety regulations for handling loads.
- Operate the lifting system from the driver's seat only.

### Lifting/lowering the fork carriage

To lift the fork carriage:

- Move the "lift mast" 360° lever (1) in the direction of arrow (B)

To lower the fork carriage:

- Move the "lift mast" 360° lever (1) in the direction of arrow (A)

### Tilting the lift mast

To tilt the lift mast forwards:

- Move the "lift mast" 360° lever (1) in the direction of arrow (C)

To tilt the lift mast backwards:

- Move the "lift mast" 360° lever (1) in the direction of arrow (D)



### NOTE

The symbols on the 360° lever show the direction of movement of the lift mast and the fork carriage when the 360° lever is moved.

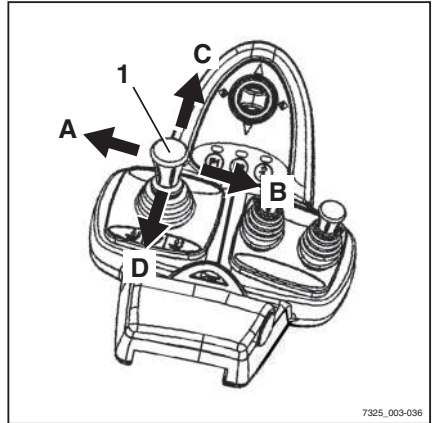

7325\_003-036

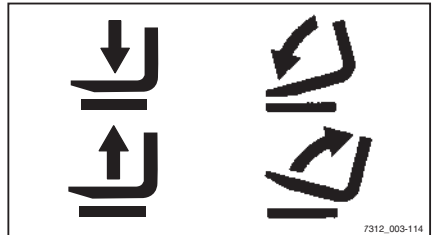

7312\_003-114

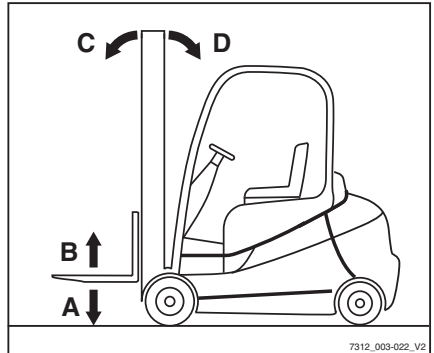

7312\_003-022\_V2

## Lifting

## Controlling the lifting system using a quadruple mini-lever ▷

### **⚠ DANGER**

Reaching into or climbing between moving parts of the truck (e.g. lift mast, sideshifts, working equipment, load carrying devices etc.) can lead to serious injury or death and is therefore prohibited.

- Observe the safety regulations for handling loads.
- Operate the lifting system from the driver's seat only.

### Tilting the lift mast

To tilt the lift mast forwards:

- Move the "lift mast" operating lever (1) in the direction of arrow (A).

To tilt the lift mast backwards:

- Move the "lift mast" operating lever (1) in the direction of arrow (B).

### Lifting/lowering the fork carriage

To lift the fork carriage:

- Move the "lift-lower" operating lever (2) in the direction of arrow (D).

To lower the fork carriage:

- Move the "lift-lower" operating lever (2) in the direction of arrow (C).

### **i** NOTE

The symbols on the operating levers show the direction of movement of the lift mast or fork carriage when the operating lever is moved.

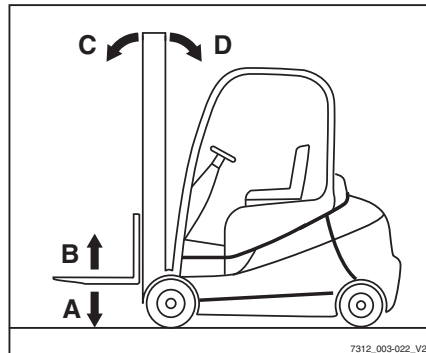
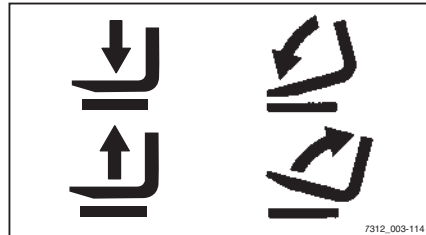
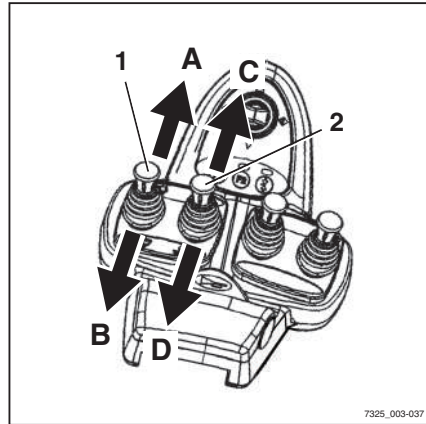



## Controlling the lifting system using the joystick 4Plus

### **⚠ DANGER**

Reaching into or climbing between moving parts of the truck (e.g. lift mast, sidershifts, working equipment, load carrying devices etc.) can lead to serious injury or death and is therefore prohibited.

- Observe the safety regulations for handling loads.
- Only operate the lifting system from the driver's seat.

### Lifting/lowering the fork carriage

To lift the fork carriage:

- Pull the joystick 4Plus (1) backwards (B).

To lower the fork carriage:

- Push the joystick 4Plus (1) forwards (A).

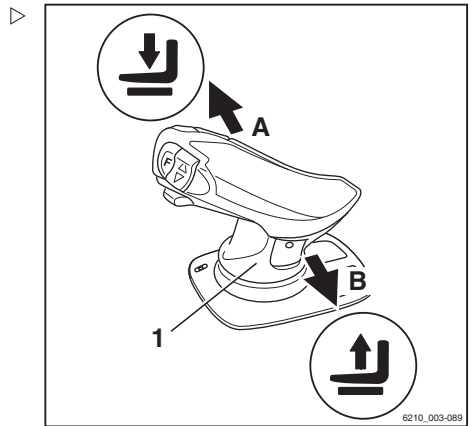

### Tilting the lift mast

To tilt the lift mast forwards:

- Tilt the horizontal rocker button (2) to the left (D).

To tilt the lift mast backwards:

- Tilt the horizontal rocker button (2) to the right (C).

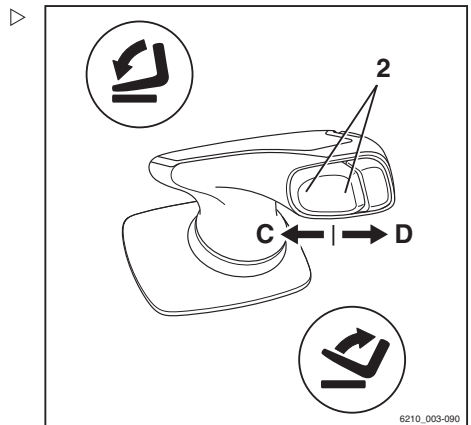

## Lifting

**Fork-carriage sideshift**

To move the fork carriage to the left.

- Push the joystick 4Plus (1) to the left (E).

To move the fork carriage to the right:

- Push the joystick 4Plus (1) to the right (F).

** NOTE**

*The symbols on the joystick 4Plus indicate the direction of movement of the lift mast or the fork carriage.*

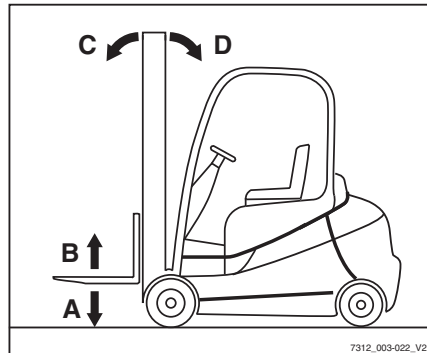
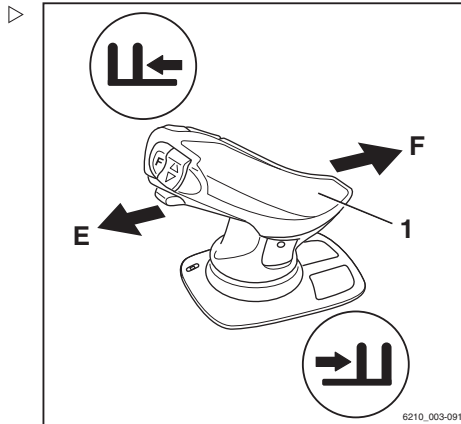

## Controlling the lifting system using the fingertip

### **⚠ DANGER**

Reaching into or climbing between moving parts of the truck (e.g. lift mast, sideshifts, working equipment, load carrying devices etc.) can lead to serious injury or death and is therefore prohibited.

- Observe the safety regulations for handling loads.
- Operate the lifting system from the driver's seat only.

### Lifting/lowering the fork carriage

To lift the fork carriage:

- Pull the "lift/lower" operating lever (1) backwards.

To lower the fork carriage:

- Push the "lift/lower" operating lever (1) forwards.

### Tilting the lift mast

To tilt the lift mast forwards:

- Push the "tilt" operating lever (2) forwards.

To tilt the lift mast backwards:

- Pull the "tilt" operating lever (2) backwards.

### **i** NOTE

The symbols on the operating levers show the direction of movement of the lift mast or fork carriage when the operating lever is moved.

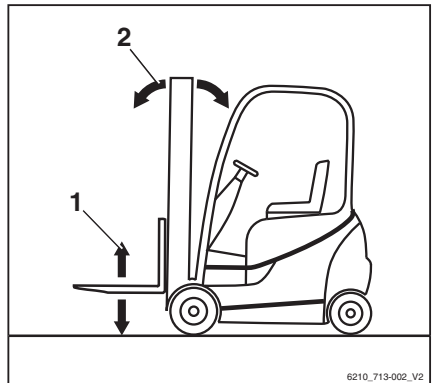
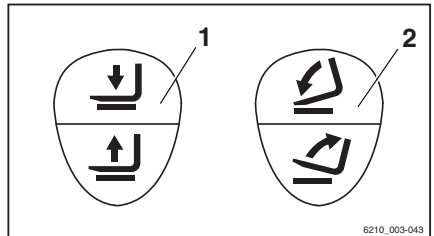
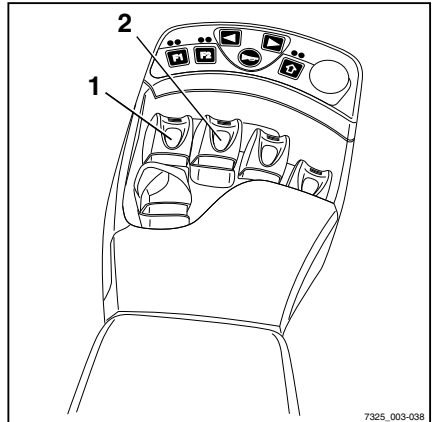

## Lifting

## Changing the fork arms

**⚠ DANGER**

**There is a risk of being run over if the truck rolls away, and therefore a danger to life.**

- Do not park the truck on a gradient.
- Apply the parking brake.
- Change the fork arms in a separate, safe location on a level surface.

**⚠ WARNING**

There is a risk of injury when changing the fork arms; the fork arms' weight could cause them to fall on your legs, feet or knees. The space to the left and right of the fork is a danger area.

- Always wear protective gloves and safety footwear when changing the fork arms.
- Ensure that no one stands in the danger area!
- Do not pull on the fork arms.
- The fork arms must always be carried by two people; if necessary, use a hoist.

**NOTE**

- *For installation and removal, a transport pallet is recommended for supporting the fork arms. The pallet size depends on the fork arm size used and should be dimensioned such that the fork arms do not protrude after being placed on the pallet. This means the fork arms can be safely placed down and transported.*
- *Both fork arms can be pushed over onto one side.*

## Removal

- Select a pallet corresponding to the fork arm size.
- Position the pallet to the left or right of the fork carriage.
- Raise the fork carriage until the lower edges of the fork arms are approx. 3 cm higher than the height of the pallet.
- Actuate the parking brake and make sure it is applied securely.
- Turn the switch key to the left and remove it.
- Undo the locking screw (2) on the right or left.
- Pull the locking lever (1) upwards and push the fork arms outwards onto the pallet.

## Installation

- Position the fork arms to the left or right of the fork carriage on a pallet.
- Push the fork arms onto the fork carriage from the outside towards the centre.
- Pull the locking lever (1) upwards and push the fork arms into the required position. Ensure that the locking lever snaps into place.
- Fit and tighten the locking screw (2).

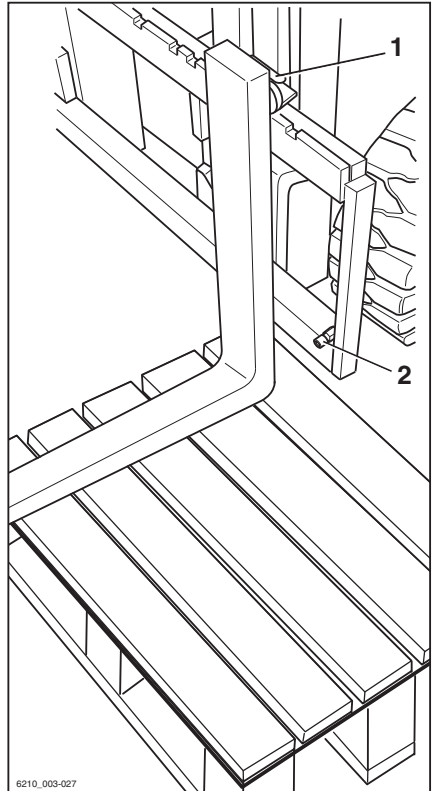

6210\_003-027

## DANGER

**There is a risk of life caused by a falling load or fork!**

- Tighten the locking screw after every fork replacement.
- It is not permitted to drive or transport loads without the locking screw.

## NOTE

*If the truck is equipped with the "load measurement" comfort feature, then a "zero adjustment of the load measurement" is imperative after the fork arms have been changed; see ⇒ Chapter "Zero adjustment of the load measurement (variant)", P. 5-107. Otherwise correct measurement of the load cannot be guaranteed.*

## Lifting

**Fork extension (variant)****⚠ DANGER**

**There is a risk of being run over if the truck rolls away and therefore a danger to life.**

- Do not park the truck on a slope.
- Apply the parking brake.
- Change the fork extension in a separate, safe location on a level surface.

**⚠ WARNING**

There is a risk of crushing!

The weight of the fork extension can cause crushing or cuts on sharp edges or burrs.

- Always wear protective gloves and safety footwear.

**⚠ WARNING**

There is a risk of tipping!

The weight and dimensions of the fork extension affect the stability of the truck. The permissible weights stated on the capacity rating plate must be reduced in proportion to the actual load distance.

- Observe load capacity, see the "Before picking up a load" chapter.

** NOTE**

*If the truck is equipped with the "load measurement" comfort feature, a "zero adjustment of the load measurement" is imperative after the fork extension has been changed; see the "Zero adjustment of the load measurement" chapter. Otherwise, correct load measurement cannot be guaranteed.*

## Attachment

### **⚠ DANGER**

#### **Risk to life from falling load!**

At least 60% of the length of the fork extension must lie on the fork arm. A maximum 40% overhang over the fork arm end is permissible. The fork extension must also be secured against slipping from the fork arm.

If the fork extension (1) is not secured with a securing bolt (2) and linch pin (3), the load with the fork extension may fall.

- Push the fork extension completely to the back of the fork.
  - Make sure that 60% of the length of the fork extension is on the fork arm.
  - Always secure the fork extension with a securing bolt.
  - Always secure the securing bolt with a linch pin.
- 
- Remove the linch pin (3) from the securing bolt (2).
  - Remove the securing bolt from the fork extension (1).
  - Push the fork extension onto the fork arms until it is flush with the fork back.
  - Insert the securing bolts located behind the fork back fully into the fork extension.
  - Insert the linch pin into the securing bolt and secure.

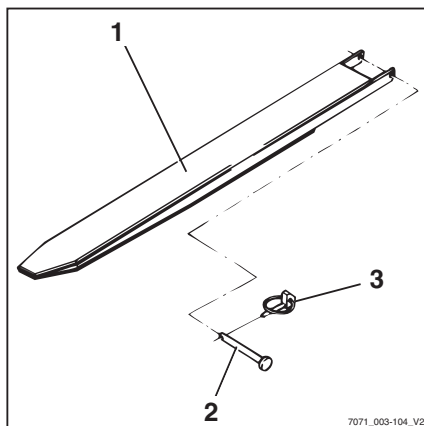

## Removal

- Remove the linch pin (3) from the securing bolt (2).
- Remove the securing bolt from the fork extension (1).
- Pull the fork extension from the fork arms.
- Insert the securing bolt fully into the fork extension.
- Insert the linch pin into the securing bolt and secure.

## Lifting

## Operation with reversible fork arms (variant)

### Normal operation

The reversible fork arms (variant) can be lifted and tilted with the lift mast in the same manner as a normal fork.

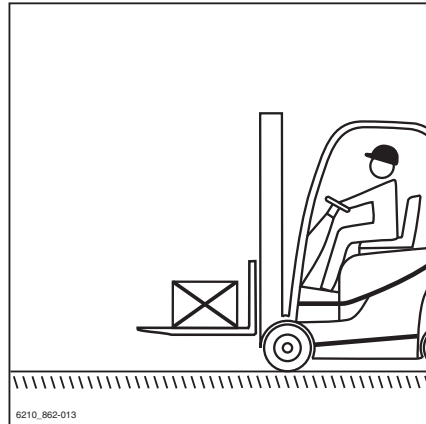

### Reverse operation

#### DANGER

#### Risk to life from falling load!

Standard fork arms are not structurally designed for reverse operation. If this is not observed, this can lead to material failure and the load falling.

- Do not carry out reverse operation with the standard fork arms.

#### WARNING

Risk of accident from slipping load!

Loads may slip on the fork arms (1) if there is no load support. A fork extension (variant) cannot be secured against slipping.

- Load pick-up on the fork arms is not permitted.
- The fork extension (variant) must not be used.

#### WARNING

Risk of accident from the truck tipping over.

When driving, the centre of gravity of the load (2) must not be higher than 600 mm above the ground. The truck may tip forwards when driving or braking.

- Only drive with the load centre of gravity up to a max. of 600 mm above the ground.

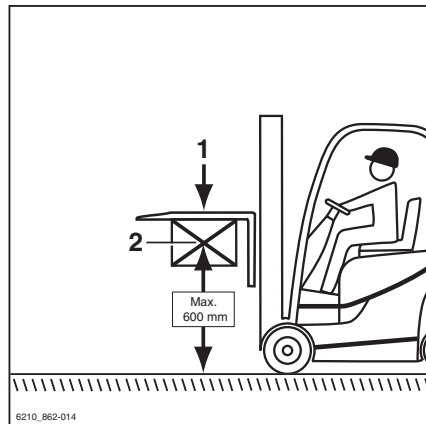



 **NOTE**

*If the truck is equipped with the "load measurement" comfort feature, then a "zero adjustment of the load measurement" is obligatory after the reversible fork arms have been changed; see → Chapter "Zero adjustment of the load measurement (variant)", P. 5-107. Otherwise, correct load measurement cannot be guaranteed.*

## Handling loads

## Handling loads

## Safety regulations when handling loads

The safety regulations for handling loads are shown in the following sections.

**⚠ DANGER**

**There is a risk to life caused by falling loads or if parts of the truck are being lowered.**

- Never walk or stand underneath suspended loads or raised fork arms.
- Never exceed the maximum load indicated on the capacity rating plate. Otherwise stability cannot be guaranteed!

**⚠ DANGER**

**Risk of accident from falling or crushing!**

- Do not step onto the forks.
- Do not lift people.
- Never grab or climb on moving parts of the truck.

**⚠ DANGER**

**Risk of accident from a falling load!**

- When transporting small items, attach a load safety guard (variant) to prevent the load from falling on the driver.
- Use a closed roof covering (variant) in addition.



## Before taking up load

### Load capacity

The load capacity indicated for the truck on the capacity rating plate may not be exceeded. The load capacity is influenced by the load centre of gravity and the lift height as well as by the tyres, if applicable.

The position of the capacity rating plate can be found in the chapter entitled "Identification points".

#### **⚠ WARNING**

The figures show examples.

Only the capacity rating plates on the truck are valid!

The attachment of additional weights to increase load capacity is prohibited.

#### **⚠ DANGER**

#### **Risk to life from the truck losing stability!**

Never exceed the maximum loads shown! These values apply to compact and homogenous loads. Otherwise, the stability as well as the rigidity of the fork arms and lift mast cannot be guaranteed.

Improper or incorrect operation or the placement of persons to increase load capacity is prohibited.

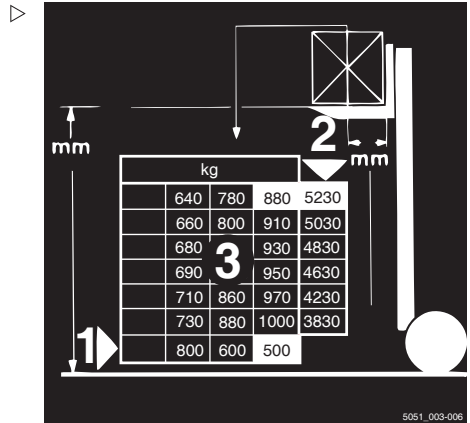

## Handling loads

### Example

Weight of load to be lifted: 880 kg (3)

Load distance from fork back: 500 mm (1)

Permitted lift height: 5230 mm (2)

#### **⚠ WARNING**

Risk of accident from the truck losing stability!

The permissible load of the attachments (variant) and the reduced lifting capacity of the combination of truck and attachment must not be exceeded.

- Observe the special capacity rating plate information shown on the truck and the attachment.

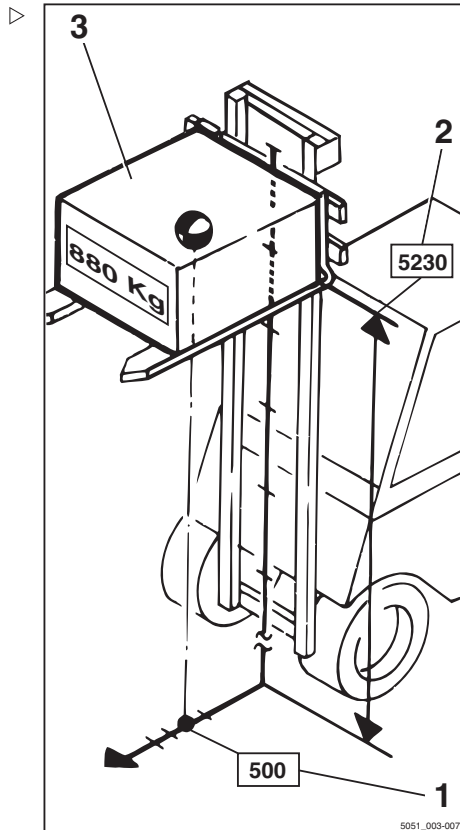

## Load measurement (variant)

### Description

Knowing the weight of the load to be transported gives the driver greater security. If the truck is equipped with the "load measurement" (variant) comfort feature, the weight of the lifted load can be measured and shown in the display and operating unit.

Load measurement is possible only when the truck is at a standstill. Before performing a load measurement, the load must be raised to a height of 300-800 mm above the ground.

The load measurement has an accuracy of  $\pm 3\%$  of the rated capacity of the truck.

 **NOTE**

*In order to ensure accuracy at all times, a zero adjustment of the load measurement must be carried out. Zero adjustment is required.*

- *as part of daily commissioning*
- *after changing the fork arms*
- *after fitting or changing attachments.*

## Performing the load measurement

 **DANGER**

### Risk of accident from a falling load!

The load may fall if the load centre of gravity has not been taken into account or the load has not been picked up securely.

- Pick up the load securely; see the chapter entitled "Picking up loads".

 **CAUTION**

If the weight determined by a load measurement exceeds the permissible residual load capacity of the truck, the truck cannot be operated safely.

- Set down and reduce load immediately.
- If necessary, use another truck with sufficient load-bearing capacity.

 **NOTE**

*Accurate load measurement is only possible under the following conditions:*

- *The hydraulic oil is at normal operating temperature*
- *The load is at rest at the beginning of the load measurement*
- *The load corresponds to at least 10% of the nominal load capacity in trucks with a load capacity of up to 2.5 t*
- *The load corresponds to at least 5% of the nominal load capacity in trucks with a load capacity of 3 t and over*
- *The lift mast is in the vertical position*
- *The fork is not raised to more than 800 mm above the ground*

## Handling loads

**i** NOTE

*The method of operating the lifting system depends on the operating devices included in the truck's equipment.*

- Ensure that the truck has been in operation for a period of time before carrying out the load measurement.
- Set lift mast to vertical.
- Raise the fork to a height of 300–800 mm.
- Ensure that the load is at rest.
- Press button (1) for "load measurement"; the "load measurement" symbol (2) appears on the display highlighted in black.

**i** NOTE

*If the truck is equipped with mini-levers or fingertip operation, the "F1" button can also be pressed as an alternative.*

**i** NOTE

*During the following process, the fork carriage must be lowered slightly and then stopped abruptly. While doing so, the fork must not touch the ground, otherwise the load measurement will not be accurate. To stop the lowering procedure quickly, release the operating device for lowering so that it jumps into the zero position.*

- Lower the fork carriage slightly and release the operating device.

**i** NOTE

*When stopping the lowering process the load must be cushioned in order to create a measurable impulse.*

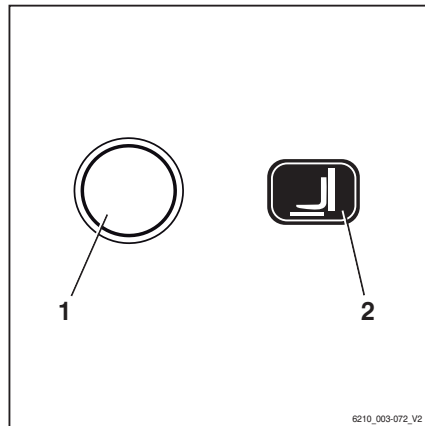

6210\_003-072\_V2

When the load measurement has been carried out correctly, the determined load weight is displayed in the operating unit. ▷

**i NOTE**

*If the load measurement is invalid, the value "-9999 kg" is displayed in the operating unit.*

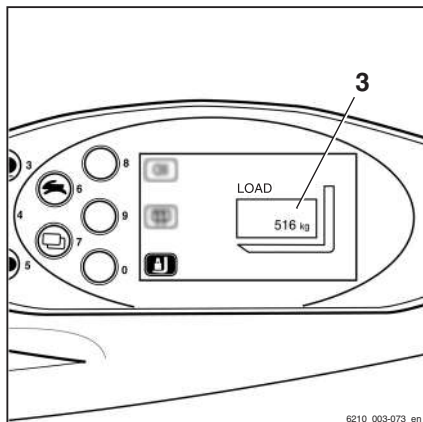

## Picking up loads

To make sure that the load is securely supported, it must be ensured that the fork arms are sufficiently far apart and are positioned as far as possible under the load.

If possible, the load should rest on the back of the fork.

The load must not protrude too far over the fork tips, nor should the fork tips protrude too far out from the load.

Loads are to be picked up and transported as close to the middle as possible.

**⚠ DANGER**

### Risk of accident from a falling load!

When transporting small items, attach a load safety guard (variant) to prevent the load from falling on the driver.

A closed roof covering (variant) should also be used.

Removable roof panels may not be removed.

## Handling loads

### Adjusting the fork

- Lift the locking lever (1) and move the fork arms to the desired position.
- Allow the locking lever to snap back into place.

The load centre of gravity must be midway between the fork arms.

- Only actuate the fork prong positioner (variant) when the fork is not carrying a load.

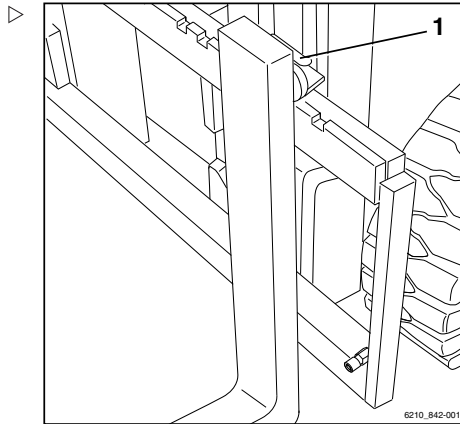

### Danger area

The danger area is the area in which people are at risk due to the movements of the truck, its working equipment, its load-carrying equipment (e.g. attachments) or the load. Also included are the areas where loads could fall or working equipment could fall or be lowered.



#### **⚠ DANGER**

##### **Risk of injury!**

- Do not step on the fork.



#### **⚠ DANGER**

##### **Risk of injury!**

- Do not step under the raised forks.

#### **⚠ DANGER**

### **People may be injured in the danger area of the truck!**

The danger area of the truck must be completely clear of all personnel, except the driver in his normal operating position. If persons fail to leave the danger area despite warnings:

- Cease work with the truck immediately.
- Secure the truck against use by unauthorised parties.





### **⚠ DANGER**

#### **Danger of death from falling loads!**

- Never walk or stand underneath suspended loads.

## Transporting pallets

As a rule, loads (e.g. pallets) must be transported individually. Transporting multiple loads at the same time is only permitted:

- when instructed by the supervisor and
- when the technical requirements have been met.

The driver must ensure proper condition of the load. Only safely and carefully positioned loads may be transported.

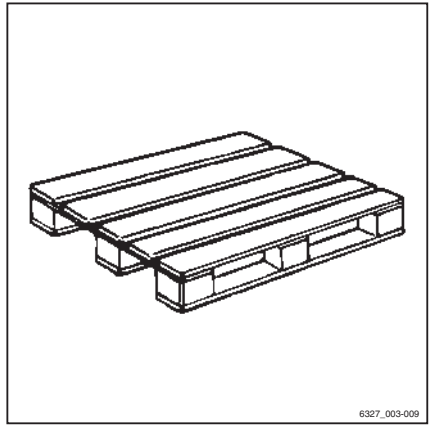

6327\_003-009

## Transport of swinging loads

Contact your national regulatory authorities (employer's liability insurance associations in Germany) prior to transporting swinging loads.

National regulations may place restrictions on these operations. Contact the relevant authorities.

### **⚠ DANGER**

#### **Swinging loads can result in the following risks:**

- Impaired braking and steering action
- Tipping over the load wheels or drive wheels
- Tipping the truck at right angles to the direction of travel
- Risk of crushing of guide persons
- Reduced visibility.



6210\_001-007

## Handling loads

### DANGER

#### **Loss of stability due to slipped, unstable or, in particular, hanging loads!**

The following information should be noted when transporting hanging loads:

- Swinging of the load is to be prevented by using the proper driving speed and driving manner (careful steering, braking).
- Hanging loads must be coupled to the truck in such a way that the harness cannot shift or release unintentionally, and cannot be damaged.
- Take particular care to ensure that there are no persons in the direction of travel in the driving lane.
- Ensure that swinging loads do not put persons at risk.
- When transporting hanging loads, suitable devices (e.g. guy wires or hand rails) are to be made available and used by guide persons.

### DANGER

#### **Risk of accidents!**

When transporting hanging loads, never abruptly perform or end driving and load movements during transport.

Never drive on slopes with a hanging load!

Containers with fluids cannot be transported as hanging loads.

## Load pick up

### DANGER

#### **There is a risk to life caused by a falling load or if parts of the truck are being lowered.**

- Never walk or stand underneath suspended loads or raised fork arms.
  - Never exceed the maximum load values specified on the capacity rating plate. Otherwise, stability cannot be guaranteed.
- 
- Only store pallets which do not exceed the specified maximum size. Damaged loading equipment and incorrectly formed loads must not be stored.

- Attach or secure the load to the load-carrying equipment so that the load cannot move or fall.
- Store the load so that the specified aisle width is not reduced by protruding parts.
- Approach the racking carefully, brake gently and stop just in front of the racking. ▷

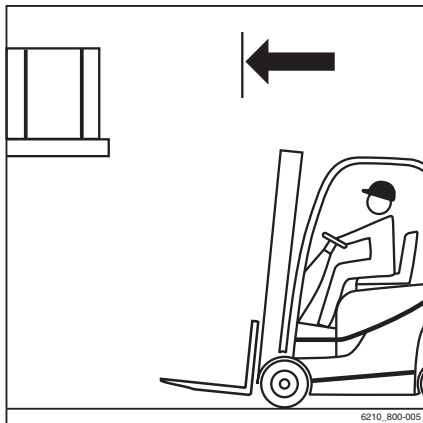

- Position the forks.
- Set lift mast to vertical.
- Lift the fork carriage to the stacking height.

**⚠ CAUTION**

Component damage possible!

When inserting the fork into the racking, ensure that the racking and load are not damaged.

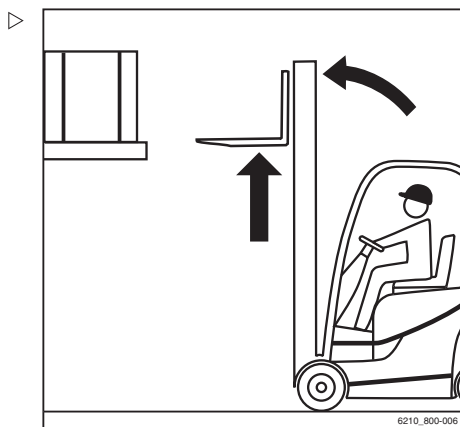

## Handling loads

- Insert the fork as far under the load as possible. Stop the truck as soon as the fork back is resting on the load. The centre of gravity of the load must be positioned between the fork arms in the middle.



- Lift the fork carriage until the load is resting entirely on the forks.

### **⚠ DANGER**

#### **Risk of accidents!**

- Beware of any people in the danger area.

### **⚠ CAUTION**

Component damage possible!

- Ensure that the roadway behind you is clear.
- Move backwards carefully and slowly until the load is clear of the racking. Brake gently.

### **⚠ DANGER**

#### **Never tilt the lift mast with a raised load due to the risk of tipping!**

- Lower the load before tilting the lift mast.

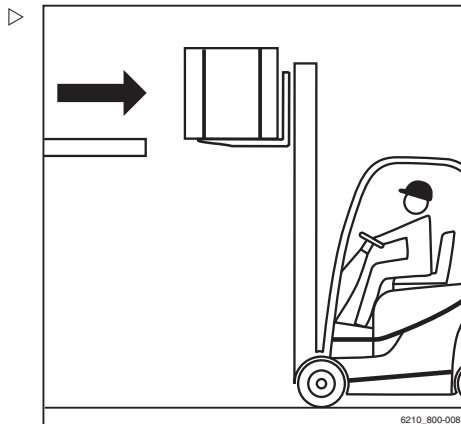

- Lower the load while maintaining ground clearance.

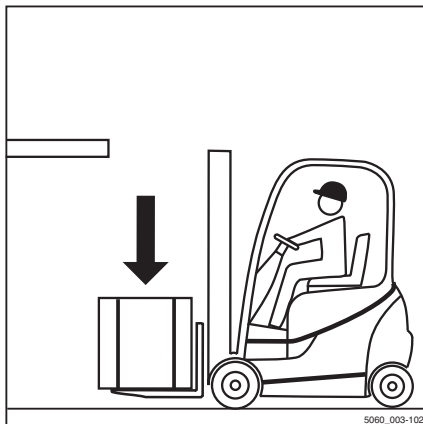

- Tilt the lift mast backwards.  
The load can be transported.

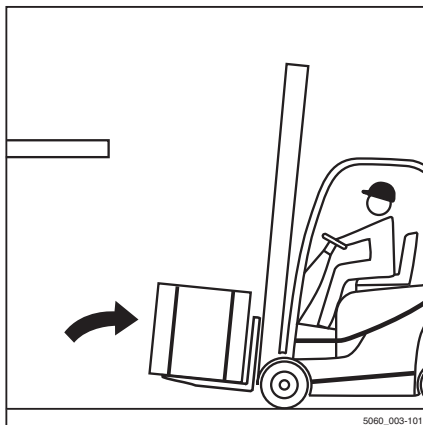

## Handling loads

## Transporting loads

**i** NOTE

Observe the information in the chapter entitled "Safety regulations when driving".

**⚠ DANGER**

**The higher a load is lifted, the less stable it becomes. The truck can tip over or the load can fall, increasing the risk of accident!**

Driving with a raised load and the lift mast tilted forward is not permitted.

- Only drive with the load lowered.
  - Lower the load until ground clearance is reached (not over 300 mm).
  - Only drive with the lift mast tilted backwards.
- 
- Drive slowly and carefully round corners!

**i** NOTE

Observe the information in the chapter entitled "Steering".

- Always accelerate and brake gently!

**i** NOTE

Observe the information in the chapter entitled "Operating the service brake".



- Never drive with a load protruding to the side (e.g. with the sideshift)

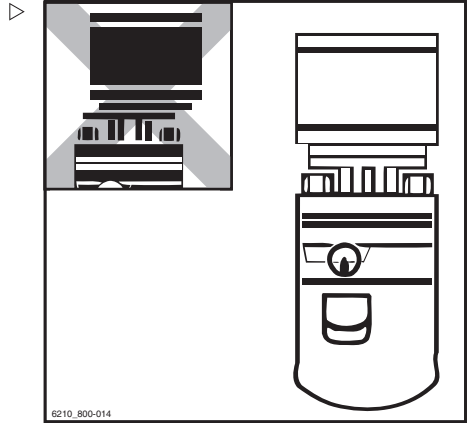

## Setting down loads

### **⚠ DANGER**

#### **Risk of accident due to changed moment of tilt!**

Please note that the lift mast can be tilted far enough forward with a raised load to cause the truck to tip over.

The load centre of gravity and the moment of tilt both change when the load slips. The truck may tip forwards.

- Only tilt the lift mast forwards with a raised lifting accessory when it is directly above the stack.
- When the lift mast is tilted forward, take particular care to ensure that the truck does not tip forwards and that the load does not slip.

### **⚠ WARNING**

Risk of accident from a falling load!

If the fork or the load remains suspended during lowering, the load may fall.

- When removing from stock, move the truck far enough back so that the load and the fork can be lowered freely.

### **i NOTE**

*If the truck is to be used to store a raised load with the lift mast tilted forwards, e.g. in a rack with sloping racking channels, an additional*

## Handling loads

*load capacity diagram must be created as the stability will be affected.*

- *Contact the authorised service centre on this matter.*
- Drive up to the stack with the load lowered in accordance with regulations. ▷
- Set lift mast to vertical.
- Lift the load to the stacking height.
- Drive the truck towards the rack carefully.



- Lower the load until it rests securely on the rack. ▷

### **⚠ DANGER**

#### **Risk of accident!**

- Beware of any people in the danger area.
  - Ensure that the roadway behind you is clear.
- 
- Move the truck back until the fork arms can be lowered without touching the stack.
  - Lower the fork while maintaining ground clearance.
  - Tilt the lift mast backwards and drive away.





## Driving on ascending and descending slopes

### **⚠ DANGER**

#### **Danger to life!**

On ascending and descending slopes the load must be carried facing uphill.

It is only permitted to drive on ascending and descending slopes if they are marked as traffic routes and can be used safely.

The driver must check that the ground is clean with a good grip.

It is not permitted to perform turns on ascending slopes, to approach them diagonally or to park the truck on them.

Drive at a reduced speed on descending slopes.

It is not permitted to put items into stock or to remove them from stock while on an ascending or descending slope.

The forklift truck should not be parked on a slope.

- In case of emergency, secure the truck with chocks.



## Driving on lifts

The driver may only use this truck on lifts with a sufficient rated capacity and for which the operating company has been granted authorisation.

### **⚠ DANGER**

**There is a risk to life if you are crushed or run over by the truck.**

- There must be no personnel already in the lift when the truck is driven into the lift.
- Personnel are only permitted to enter the lift once the truck is secure, and must exit the lift before the truck is driven out.

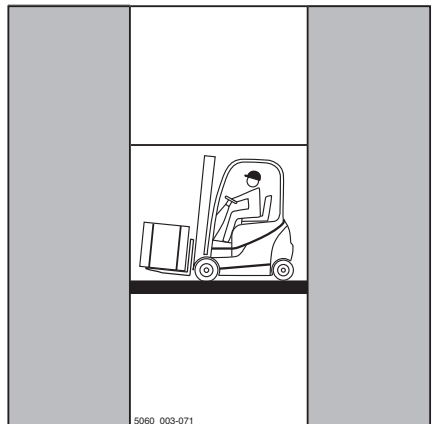

## Handling loads

### Determining the actual total weight

- Park the truck securely.
- Determine the unit weights by reading the truck nameplate and, if necessary, the attachment (variant) nameplate and, if necessary, by weighing the load to be lifted.
- Add the determined unit weights to obtain the actual total weight of the truck:

Tare weight (1)

+ Ballast weight (variant) (2)

+ Attachment net weight (variant)

+ Weight of the load to be lifted

+ 100 kg allowance for driver

= Actual total weight

- Drive the truck with the forks forwards into the lift without touching the shaft walls.
- Park the truck securely in the lift to prevent uncontrolled movements of the load or the truck.

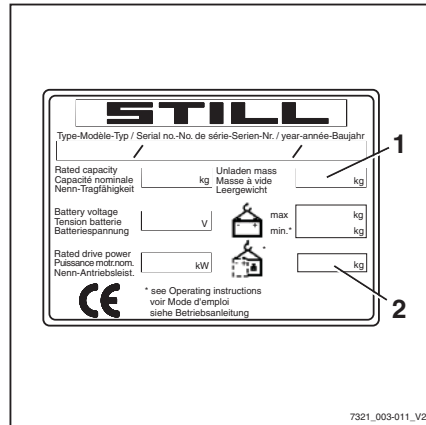

### Driving on loading bridges



#### **⚠ DANGER**

#### Risk of accident if the truck crashes!

Steering movements can cause the tail end to veer off the loading bridge towards the edge. This may cause the truck to crash.

The lorry driver and the truck driver must agree on the lorry's departure time.

- Before driving across a loading bridge, ensure that it is properly attached and secured and has a sufficient load capacity (lorry, bridge etc.).
- Drive slowly and with care on the loading bridge.
- Ensure that the vehicle onto which you will be driving is secured to prevent it from shifting and that it can support the load of the truck.

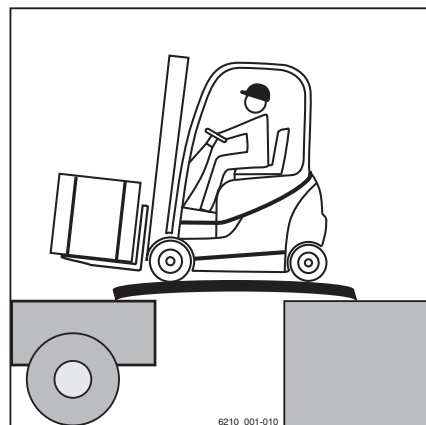

### Determining the actual total weight

- Park the truck securely.
- Determine the unit weights by reading the truck nameplate and, if necessary, the attachment (variant) nameplate and, if necessary, by weighing the load to be lifted.
- Add the determined unit weights to obtain the actual total weight of the truck:

Tare weight (1)

- + Ballast weight (variant) (2)
- + Attachment net weight (variant)
- + Weight of the load to be lifted
- + 100 kg allowance for driver
- = Actual total weight

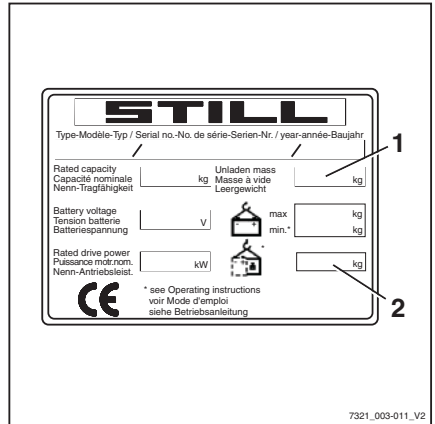

## Particle filter system

### Particle filter - Function

#### **⚠ DANGER**

**Risk to health from exhaust gases! Exhaust gases from internal combustion engines are harmful to your health. In particular, the soot particles contained in the diesel exhaust gas can cause cancer. Allowing the internal combustion engine to idle represents a risk of poisoning from the CO, CH and NO<sub>x</sub> components contained in the exhaust gas.**

Modern exhaust gas treatment systems (e.g. catalytic converters, particle filters or comparable systems) can clean exhaust gases in a way that reduces the health hazard and risk of poisoning when operating the truck.

- Observe the national laws and regulations when using trucks with an internal combustion engine in entirely or partially enclosed working areas.
- Always ensure that there is sufficient ventilation available.

This truck is equipped with a closed particle filter system that filters carcinogenic soot particles out of the exhaust gas and collects them in the particle filter.

## Particle filter system

The use of a particle filter is recommended for applications in closed halls with a low degree of ventilation.

### Operating principle during normal operation

The soot particles that are filtered out of the exhaust gas and collected in the filter are removed by means of a continuous regeneration process.

This process requires a sufficiently high exhaust gas temperature, which is also reached during normal operation. The truck is then used to such a degree that it burns off the soot during operation. The driver must not interfere with this process. No other consumables (e.g. additives) are required.

### Operating principle during low-load operation

If the truck is used little, a sufficiently high exhaust gas temperature may not be reached. In addition, very low ambient temperatures may prevent a sufficiently high exhaust gas temperature being reached. This causes the regeneration process to be disrupted. The soot filtered out of the exhaust gas then collects in the particle filter, as it is not burned off during the continuous regeneration process. In this case, a parked regeneration of the particle filter must be performed. This regeneration process, which takes approx. 30 minutes, can only be performed when the truck is stationary, meaning the truck cannot be used during this time. The driver is informed of the need for a parked regeneration in advance by means of corresponding messages on the display and operating unit. Details of these messages are provided in the chapter entitled "Messages regarding parked regeneration on the display and operating unit".

### Interrupting parked regeneration

Releasing the parking brake during parked regeneration interrupts the parked regeneration process.

In the display and operating unit, the following message appears: `PARK . REG . ERROR`.

 **NOTE**

*If regeneration is interrupted too frequently, additional engine maintenance may be required from the authorised service centre.*

- Apply the parking brake.
- Restart parked regeneration.

The restarted parked regeneration requires another 30 minutes to complete, no matter how complete the interrupted parked regeneration was.

If the display message `PARK . REG . ERROR` appears more than twice in succession without the parking brake being released during parked regeneration, there may be a malfunction in the internal combustion engine.

- Notify the authorised service centre.

## Particle filter - Performing parked regeneration

 **CAUTION**

Risk of damage to components! If parked regeneration is not performed when required, the particle filter may become damaged.

A full parked regeneration must be performed in order to completely empty the particle filter.

 **CAUTION**

During the parked regeneration process, very hot combustion gases escape from the exhaust pipe!

The parked regeneration must not be performed in areas containing hazardous materials or highly flammable materials, or in a hall. In addition, the following instructions must be observed exactly.

During parked regeneration, the surface temperature of the exhaust gas system is higher than the usual operating temperature. This can cause adhering dust and oils to ignite. If the truck is operated with an exhaust gas extraction unit, parked regeneration is not permitted. The operating company must

## Particle filter system

determine whether parked regeneration is permitted where the truck is being used or whether the truck must be moved to a separate area for this purpose.

The parked regeneration must be carried out while the internal combustion engine is running. During the regeneration process, the truck automatically changes the speed of the internal combustion engine. The driver cannot influence this change. If the parked regeneration requested by the truck is not performed and this remains the case for an extended period of time, the particle filter may become damaged. If this happens, it would need to be repaired by your authorised service centre.

Before performing parked regeneration, the following points must be observed:

- Observe the operating instructions from the operating company
- Always thoroughly clean dust, oils and other settling substances from the exhaust gas system
- Remove any connected exhaust gas extraction units
- Perform parked regeneration in a suitable place



### NOTE

*Parked regeneration can only be performed if the parking brake is engaged. If the parking brake is not engaged, APPLY HANDBRAKE ! appears on the display.*

As soon as the message EXH . GAS PURIFIER appears in the display and operating unit, parked regeneration can be performed. To do this, proceed as follows:

- Park the truck in a place that is suitable for parked regeneration.

- Switch the key switch (1) to position "0" and wait until the display has turned off. ▷
- Turn the key switch back to the "I" position.

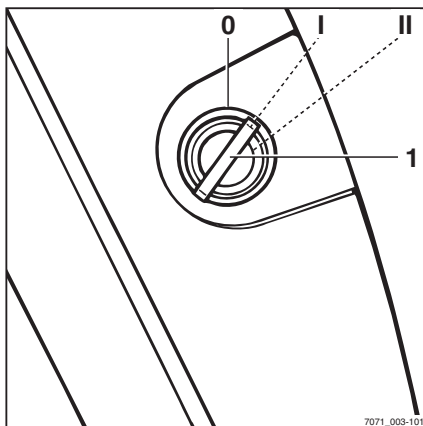

The message **START PARK. REG. ?** as well as the soft keys **OK** (1) and **ESC** (2) appear on the display. ▷

- To start the parked regeneration process, press the **OK** button (1).

The message **START IC ENGINE** appears on the display.

- To interrupt the parked regeneration process, press the **ESC** button (2).

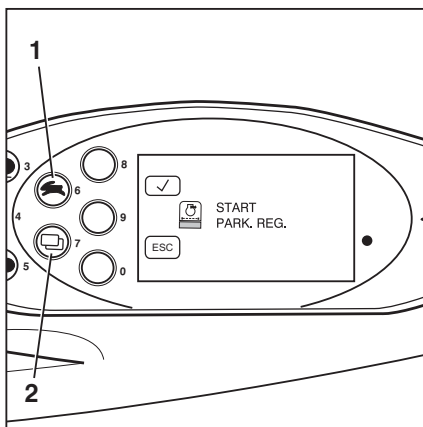

## Particle filter system

- Start the engine. To do this, turn the switch key (1) to position "II" and hold it there until the engine has started. Then release the switch key.

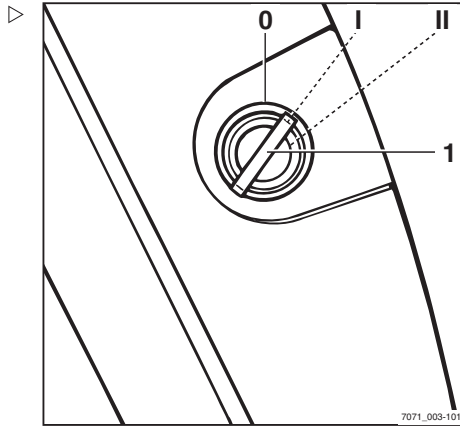

The particle filter regeneration process is started. EXH. GAS PURIFIER PLEASE WAIT appears on the display. The status bar (4) below the message indicates the regeneration progress.

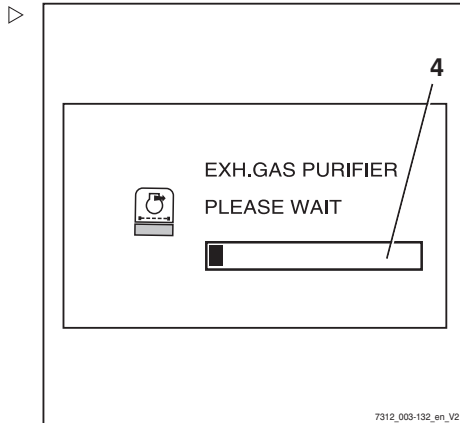

### NOTE

*During parked regeneration, the engine speed fluctuates and the power of the radiator fan is reduced. The drive unit and the hydraulic controller are switched off and do not respond when the corresponding operating devices are actuated.*



The parked regeneration process is complete when the status bar disappears and REGENERATION COMPLETED appears on the display. The truck is ready for operation again. ▷

**i NOTE**

*The system requests parked regeneration every 500 operating hours at the latest if it has not already been performed due to soot accumulation in the particle filter. The message EXH . GAS PURIFIER appears on the display and parked regeneration must be performed.*

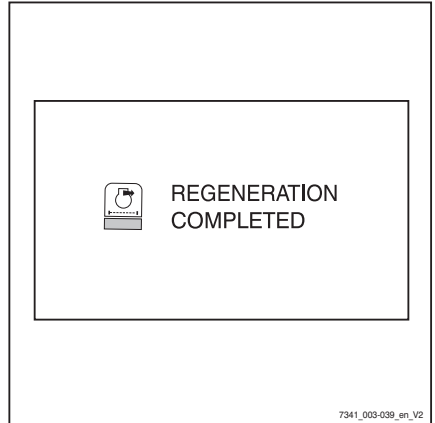

**Particle filter - Displays**

**i NOTE**

*To guarantee economic use of the truck, it is important to follow the specifications in these operating instructions exactly. If notes about particle filter regeneration shown on the screen of the display and operating unit are not observed, this can lead to longer truck downtimes.*

The following table describes the messages that appear on the display and operating unit relating to parked regeneration and if parked regeneration is not performed:

Messages	Meaning	Comment
EXH . GAS PURIFIER	Carry out parked regeneration of the particle filter.	See the section entitled "Performing parked regeneration"
START PARK . REG . ?	Prompt asking whether parked regeneration of the particle filter should now be performed.	
START IC ENGINE	Request to start the engine.	
EXH . GAS PURIFIER PLEASE WAIT	The particle filter is being regenerated.	A status bar shows the regeneration progress.
REGENERATION COMPLETED	The parked regeneration process is complete.	The truck is ready for operation again.

## Particle filter system

PARK . REG . URGENT ! ! !	Parked regeneration of the particle filter is urgently required.	Until parked regeneration has been carried out, the maximum speed of the truck is reduced to 2 km/h. The lifting speed is restricted.
PARK . REG . ERROR	Regeneration was interrupted due to an error.	The parking brake was released during parked regeneration. Apply the parking brake and restart regeneration. If the message appears more than twice in succession without the parking brake being released during parked regeneration, there may be a malfunction in the internal combustion engine. In this case, notify your authorised service centre.
ASH LOAD	The particle filter has become clogged with ash. Repair must be performed by the authorised service centre.	
EXH . GAS PURIFIER SERVICE ! ! !	Because regeneration has not been performed, the particle filter system must be repaired by the authorised service centre. To avoid further damage, take the truck out of operation until the repair has been performed.	Until the particle filter system has been repaired, the maximum speed of the truck is reduced to 2 km/h. The lifting speed is significantly restricted.

## Working with attachments

### Fitting attachments

If the truck is equipped with an integrated attachment (variant) at the factory, the specifications in the STILL operating instructions for integrated attachments must be observed.

If attachments are fitted at the place of use, the specifications in the operating instructions of the attachment manufacturer must be observed.

If an attachment is not delivered together with the forklift truck, the specifications and operating instructions of the attachment manufacturer must be observed.

Before initial commissioning, the function of the attachment and the visibility from the driver's position with and without a load must be checked by a competent person. If the visibility is deemed insufficient, visual aids such as mirrors, a camera/monitor system etc. must be used.



#### NOTE

*Please note the definition of "competent person" in the sense of responsible persons!*

#### CAUTION

Attachments must be CE-certified. If the truck is not fitted with an attachment-specific residual load capacity rating plate, and the operating devices are not marked with the relevant pictograms, the truck must not be used.

- Order the residual load capacity rating plate and pictograms from your authorised service centre in good time.
- The authorised service centre must adapt the hydraulic system to the requirements of the attachment (e.g. by adjusting the pump motor speed).

## Working with attachments

### **⚠ DANGER**

#### **There is risk to life caused by a falling load!**

Attachments that hold the load by exerting pressure on it (e.g. clamps) must be additionally controlled by a second operating function (lock) that is actuated to prevent an unintentional release of the load.

If such an attachment is retrofitted, a second operating function for actuation must also be retrofitted.

- Make sure that the additional clamp locking mechanism function is available.

### **⚠ DANGER**

#### **There is risk to life caused by a falling load!**

During installation of a clamp with integral sideshift, ensure that the clamp does not open when the sideshift is actuated.

- Notify your authorised service centre before installation.
- Never grab or climb on moving parts of the truck.

## Hydraulic connection

- Before fitting the attachment, release the pressure from the hydraulic system.

### **⚠ CAUTION**

Risk of damage to components!

Open connections of plug connectors can become dirty. The plug connectors can become stiff and dirt can enter the hydraulic system.

- Once the attachments have been disassembled, attach the protective caps to the plug connectors.

## Mounting attachments

Mounting the attachment and connecting the energy supply for power-driven attachments must only be performed by authorised personnel in accordance with the information provided by the manufacturer and supplier of the attachment. After each assembly, the attachment must be checked for correct function prior to initial commissioning.

### **i NOTE**

*Please note the definition of "competent person" in the sense of responsible persons!*

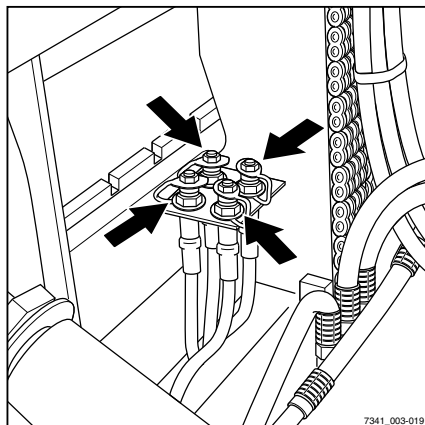

7341\_003-019

### Load capacity with attachment

The permissible load capacity of the attachment and the allowable load (load capacity and load moment) of the truck must not be exceeded in the combination of attachment and payload. The specifications of the manufacturer and supplier of the attachment must be complied with.

- Observe the residual load capacity rating plate, see the chapter entitled "Picking up a load using attachments".

### Releasing the pressure from the hydraulic system

Prior to assembling attachments, the pressure must be released from the plug connectors (see image).

Attachments must only be installed by authorised personnel in accordance with the information provided by the manufacturer and supplier of the attachments. After each installation, the attachment must be checked for correct function prior to initial commissioning.

#### **i** NOTE

*The pressure release procedure is dependent on the operating devices for controlling the hydraulic functions; see the chapter entitled "Lifting system operating devices".*

#### **i** NOTE

*Before carrying out pressure release, lower the fork carriage and tilt the lift mast back to the stop. The key switch must be switched on to release the pressure from the system, but do not start the engine.*

#### **i** NOTE

*In trucks with the "FleetManager" or "access authorisation with PIN code" equipment variants, access authorisation must be enabled.*

- Switch on the key switch.
- Wait two to three seconds.

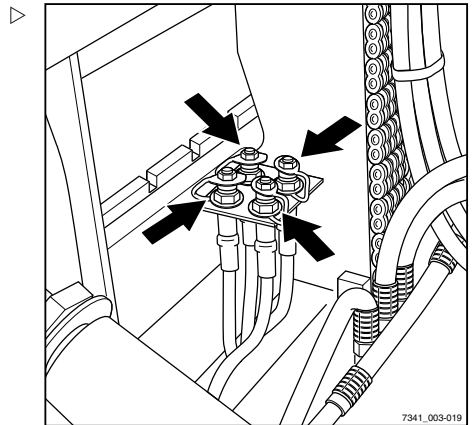

## Working with attachments

- Actuate the operating lever (1) for controlling the hydraulic functions repeatedly in the direction of the arrow, as far as the end position.

The valves open and the hydraulic system is depressurised.

- Switch off the key switch.

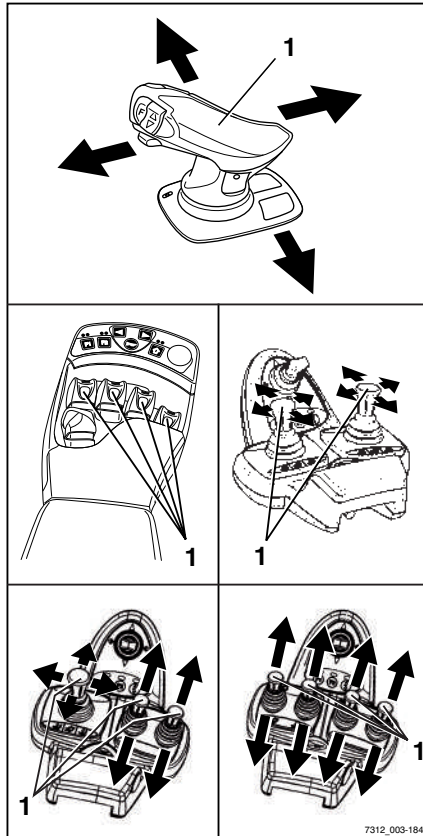

## General instructions for controlling attachments

The way in which attachments (variant) are controlled depends on the operating devices included in the truck's equipment.

Essentially, a distinction is drawn between:

- **Double mini-lever**
  - **Double mini-lever with a 5th function**  
(variant)
  - **Triple mini-lever**
  - **Triple mini-lever with a 5th function** (variant)
  - **Quadruple mini-lever**
  - **Quadruple mini-lever with a 5th function**  
(variant)
  - **Joystick 4Plus**
  - **Joystick 4Plus with a 5th function** (variant)
  - **Fingertip switch**
  - **Fingertip with a 5th function** (variant)
- For information on controlling attachments with the respective operating devices, see the relevant sections in this chapter.

### **WARNING**

Use of attachments can give rise to additional hazards such as a change in the centre of gravity, additional danger areas etc.

Attachments must only be used for their intended purpose as described in the relevant operating instructions. Drivers must be taught how to operate the attachments.

Loads may only be picked up and transported with attachments if the loads are securely grasped and attached. Where necessary, loads must also be secured against slipping, rolling away, falling over, swinging or tipping over. Note that any change to the position of the load centre of gravity will affect the stability of the truck.

- Refer to the capacity rating plate for the attachments being used.

### **NOTE**

*Further variants and functions are available in addition to the functions described below. The directions of movement can be seen on the pictograms on the operating devices.*

## Working with attachments



### NOTE

*All the attachments described fall into the category of equipment variants. Please see the respective operating instructions for an exact description of the respective movements/actions of the attachment fitted.*



## Controlling attachments using a double mini-lever

The attachments (variants) are controlled in this version using the "attachments" cross lever (1).

The pictograms on the "attachments" cross lever show the respective functions that are activated by this lever.

This essentially involves the following:

- Move the "attachments"(1) cross lever in the direction of the arrow (A) .

The attachment moves in accordance with the pictogram in position (A).

- Move the "attachments"(1) cross lever in the direction of the arrow (B) .

The attachment moves in accordance with the pictogram in position (B).

- Move the "attachments"(1) cross lever in the direction of the arrow (C) .

The attachment moves in accordance with the pictogram in position (C).

- Move the "attachments"(1) cross lever in the direction of the arrow (D) .

The attachment moves in accordance with the pictogram in position (D).

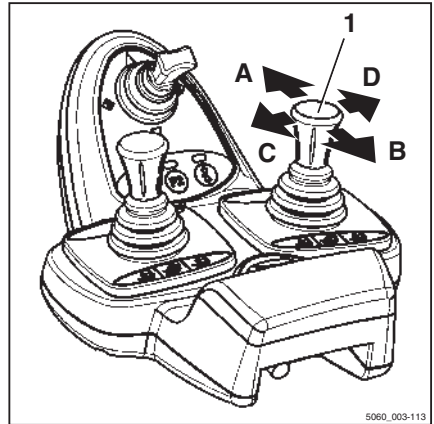

5060\_003-113

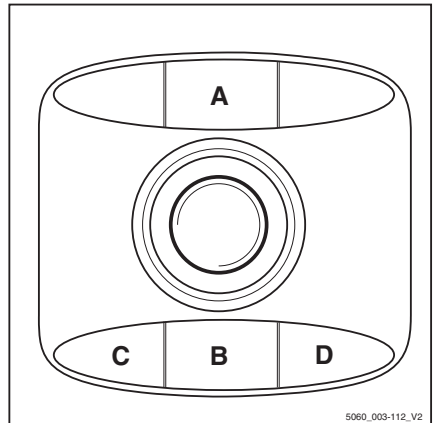

5060\_003-112\_V2

## Working with attachments

- Note the following attachment functions and pictograms. ▷

3	Move sideshift frame or fork forwards
4	Move sideshift frame or fork backwards
5	Move sideshift to the left
6	Move sideshift to the right
7	Adjust fork arms: open
8	Adjust fork arms: close
9	Swivel lift mast or fork to the left
10	Swivel lift mast or fork to the right
11	Release load retainer
12	Clamp load retainer
13	Push off the load
14	Pull in the load
15	Open clamps
16	Close clamps
17	Rotate to the left
18	Rotate to the right
19	Tip shovel over
20	Tip shovel back

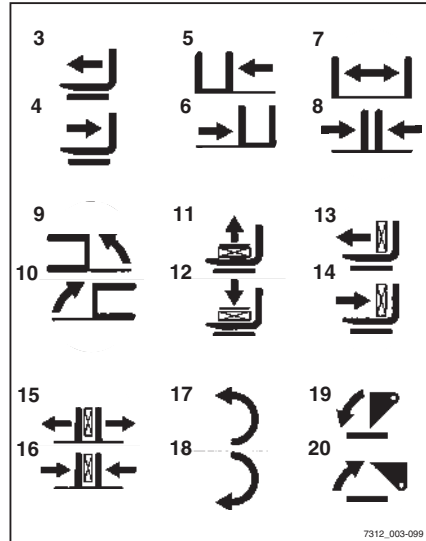

**i** NOTE

*The pictograms shown correspond to the attachments fitted to this truck at the factory. If an attachment with other functions is fitted, the pictograms must be checked for the correct representation and changed if necessary.*

- Contact the authorised service centre if required.

## Controlling attachments using the double mini-lever and the 5th function

### NOTE

The "lift mast" 360° lever and the "attachments" cross lever control four hydraulic functions. The "5th function" designation refers to the fact that switching functions using the "5th function" function key (1) control the 5th hydraulic function via the cross lever.

The pictograms on the "attachments" cross lever show the respective functions that are activated by this lever.

This essentially involves the following:

- Actuate the "5th function"(1) function key and move the "attachments"(2) cross lever in the direction of arrow (E).

The attachment moves in accordance with the pictogram in position (E).

- Actuate the "5th function" function key (1) and move the "attachments"(2) cross lever in the direction of the arrow (F).

The attachment moves in accordance with the pictogram in position (F).

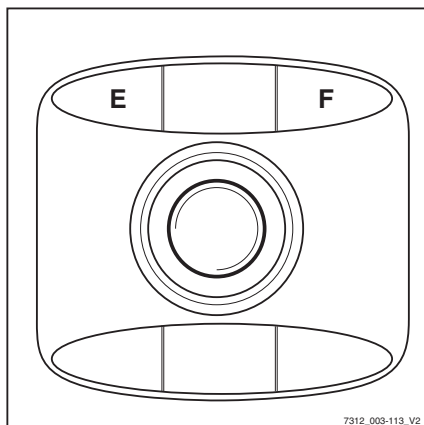
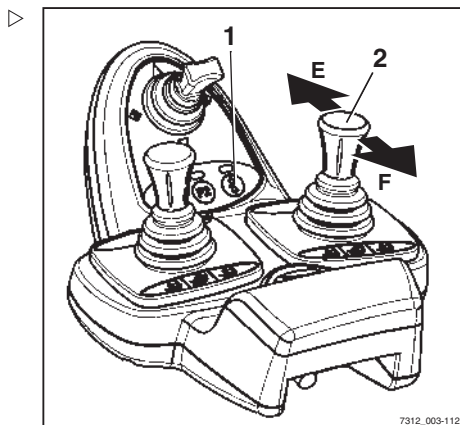

## Working with attachments

- Note the following attachment functions and pictograms. ▷

3	Move sideshift frame or fork forwards
4	Move sideshift frame or fork backwards
5	Move sideshift to the left
6	Move sideshift to the right
7	Adjust fork arms: open
8	Adjust fork arms: close
9	Swivel lift mast or fork to the left
10	Swivel lift mast or fork to the right
11	Release load retainer
12	Clamp load retainer
13	Push off the load
14	Pull in the load
15	Open clamps
16	Close clamps
17	Rotate to the left
18	Rotate to the right
19	Tip shovel over
20	Tip shovel back

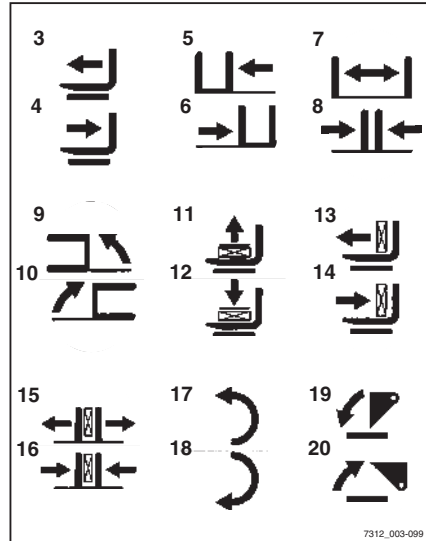

**i** NOTE

*The pictograms shown correspond to the attachments fitted to this truck at the factory. If an attachment with other functions is fitted, the pictograms must be checked for the correct representation and changed if necessary.*

- Contact the authorised service centre if required.

## Controlling attachments using a triple mini-lever

The attachments (variant) are controlled in this version using operating levers (1) and (2).

The pictograms on the operating levers show the respective functions that are activated by these levers.

This essentially involves the following:

- Move the operating lever (1) towards (A)

The attachment moves in accordance with the pictogram in position (A).

- Move the operating lever (1) towards (B)

The attachment moves in accordance with the pictogram in position (B).

- Move the operating lever (2) towards (C)

The attachment moves in accordance with the pictogram in position (C).

- Move the operating lever (2) towards (D)

The attachment moves in accordance with the pictogram in position (D).

### NOTE

*The pictograms are attached depending on the pre-assembled attachment. If an attachment with other functions is fitted, the pictograms must be checked for the correct representation and changed if necessary.*

- Contact the authorised service centre if required.

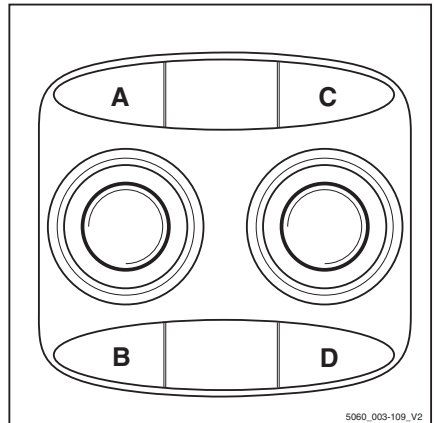
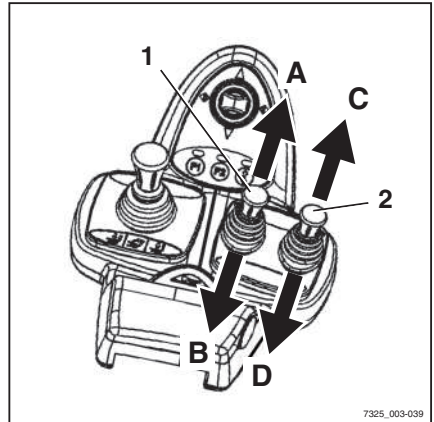

## Working with attachments

- Note the following attachment functions and pictograms! ▷

3	Move sideshift frame or fork forwards
4	Move sideshift frame or fork backwards
5	Move sideshift to the left
6	Move sideshift to the right
7	Adjust fork arms: open
8	Adjust fork arms: close
9	Swivel lift mast or fork to the left
10	Swivel lift mast or fork to the right
11	Release load retainer
12	Clamp load retainer
13	Push off the load
14	Pull in the load
15	Open clamps
16	Close clamps
17	Rotate to the left
18	Rotate to the right
19	Tip shovel over
20	Tip shovel back

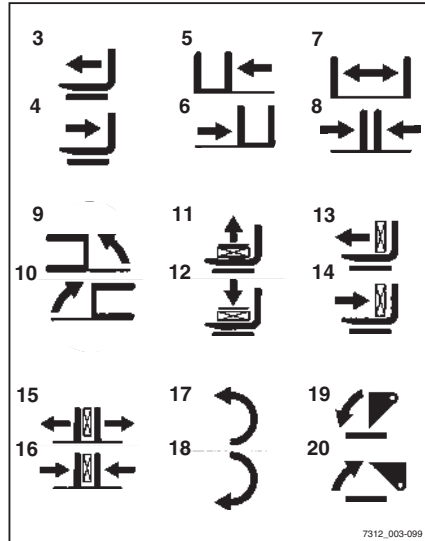

### Controlling attachments using the triple mini-lever and the 5th function

#### NOTE

Four hydraulic functions are controlled using the "lift mast" 360° lever and operating levers (1) and (2). The designation "5th function" refers to the fact that the 5th hydraulic function can be controlled with the operating lever (1) by switching the functions using the function key (3).

The pictograms on the operating levers show the respective functions that are activated by these levers.

This essentially involves the following:

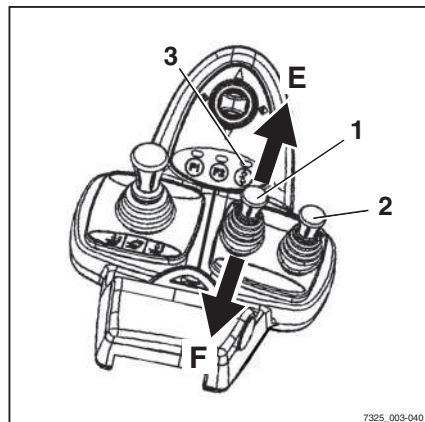

- Actuate the "5th function" function key (3) and move operating lever (1) towards (E)

The attachment moves in accordance with the pictogram in position (E).

- Actuate the "5th function" function key (3) and move operating lever (1) towards (F)

The attachment moves in accordance with the pictogram in position (F).

**i NOTE**

*The pictograms are attached depending on the pre-assembled attachment. If an attachment with other functions is fitted, the pictograms must be checked for the correct representation and changed if necessary.*

- Contact the authorised service centre if required.
- Note the following attachment functions and pictograms! ▷

1	Adjust fork arms: open
2	Adjust fork arms: close
3	Rotate to the left
4	Rotate to the right

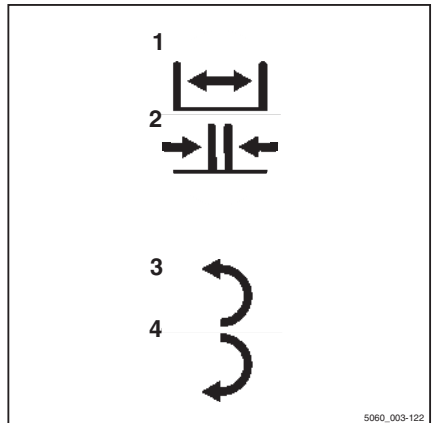
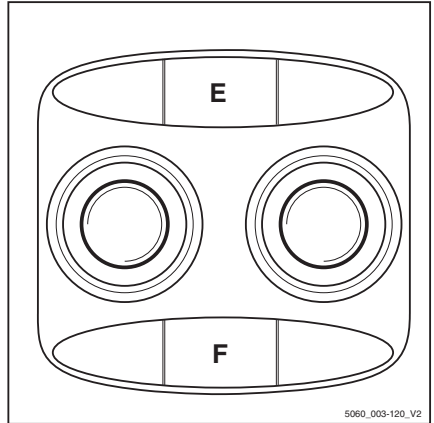

## Working with attachments

### Controlling attachments using a quadruple mini-lever

The attachments (variant) are controlled in this version using operating levers (1) and (2).

The pictograms on the operating levers show the respective function that is activated by these levers.

This essentially involves the following:

- Move the operating lever (1) towards (A)

The attachment moves in the direction shown in pictogram (A).

- Move the operating lever (1) towards (B)

The attachment moves in the direction shown in pictogram (B).

- Move the operating lever (2) towards (C)

The attachment moves in the direction shown in pictogram (C).

- Move the operating lever (2) towards (D)

The attachment moves in the direction shown in pictogram (D).

#### NOTE

*The pictograms are attached depending on the pre-assembled attachment. If an attachment with other functions is fitted, the pictograms must be checked for the correct representation and changed if necessary.*

- Contact the authorised service centre if required.

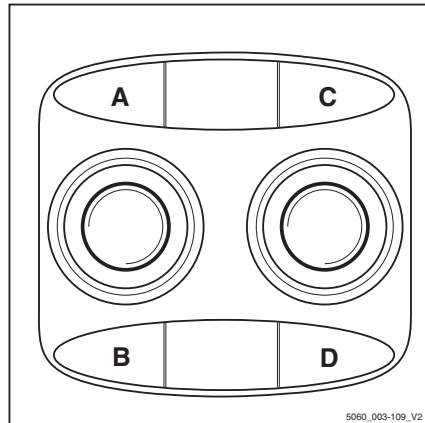
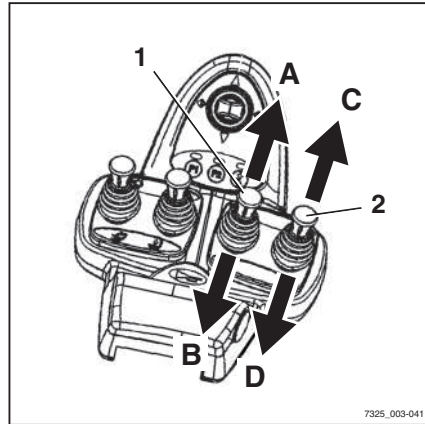



– Note the following attachment functions and pictograms!

3	Move sideshift frame or fork forwards
4	Move sideshift frame or fork backwards
5	Move sideshift to the left
6	Move sideshift to the right
7	Adjust fork arms: open
8	Adjust fork arms: close
9	Swivel lift mast or fork to the left
10	Swivel lift mast or fork to the right
11	Release load retainer
12	Clamp load retainer
13	Push off the load
14	Pull in the load
15	Open clamps
16	Close clamps
17	Rotate to the left
18	Rotate to the right
19	Tip shovel over
20	Tip shovel back

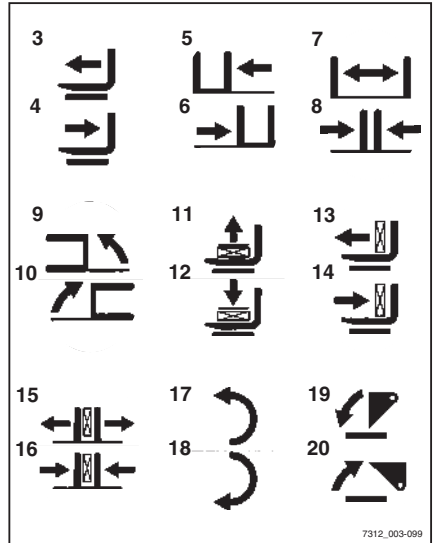

### Controlling attachments using the quadruple mini-lever and the 5th function

**i** NOTE

Operating levers (1) to (4) are used to control four hydraulic functions. The designation "5th function" refers to the fact that the 5th hydraulic function can be controlled with the operating lever (3) by switching the functions using the "5th function" (5) key.

The pictograms on the operating levers show the respective functions that are activated by these levers.

This essentially involves the following:

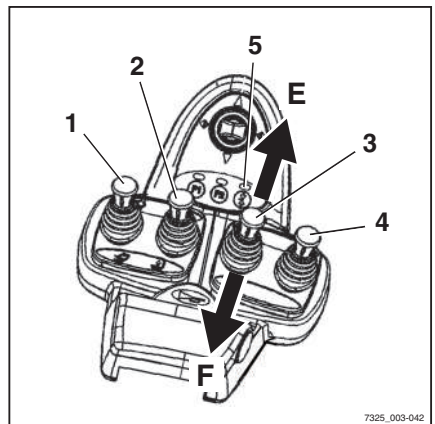

## Working with attachments

- Actuate the "5th function" function key (5) and move operating lever (3) towards (E)

The attachment moves in accordance with the pictogram in position (E).

- Actuate the "5th function" function key (5) and move operating lever (3) towards (F)

The attachment moves in accordance with the pictogram in position (F).

### NOTE

*The pictograms are attached depending on the pre-assembled attachment. If an attachment with other functions is fitted, the pictograms must be checked for the correct representation and changed if necessary.*

- Contact the authorised service centre if required.
- Note the following attachment functions and pictograms! ▷

1	Adjust fork arms: open
2	Adjust fork arms: close
3	Rotate to the left
4	Rotate to the right

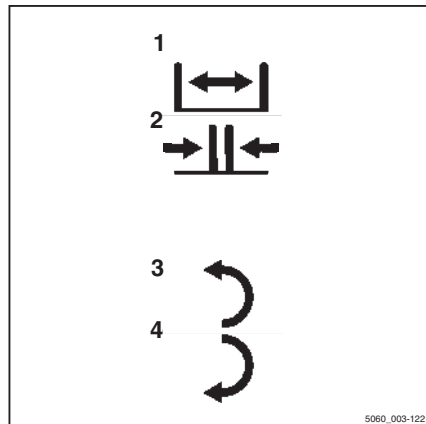
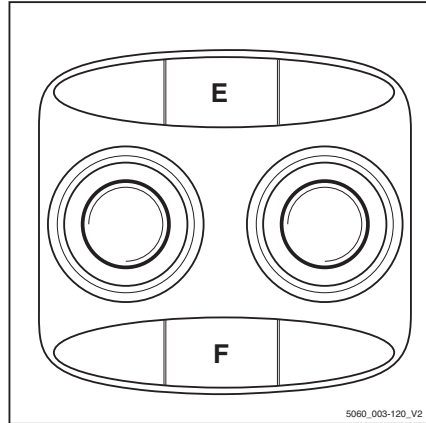

### Controlling attachments via the joystick 4Plus

In this equipment, the attachments (variant) are controlled via the joystick 4Plus (1).

The pictograms on the decal information about operation of the joystick 4Plus show the respective functions that are activated by the individual operating devices of the joystick 4Plus.

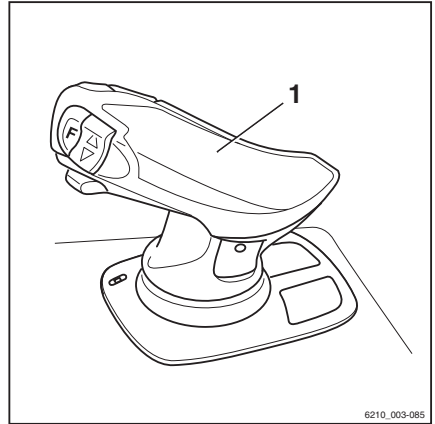

- Note the following attachment functions and pictograms.



	Operating device	Function of the attachment
1	Joystick 4Plus	Move sideshift to the left/right
2	Joystick 4Plus or slider	Adjust fork arms: open/close
3	Slider	Move reach frame or fork carriage forwards/backwards
4	Joystick 4Plus or slider	Rotate attachment left/right
5	Slider	Tip shovel over/tip shovel back

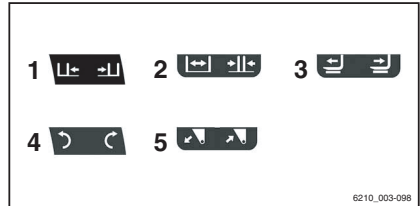

**NOTE**

*The pictograms on the joystick 4Plus are attached according to the attachments fitted to this truck at the factory. If an attachment with other functions is fitted, the pictograms must be checked for the correct representation and changed if necessary.*

- Contact the authorised service centre if required.

## Working with attachments

## Controlling attachments using the joystick 4Plus and the 5th function

- Note the following attachment functions and pictograms. ▷

	Operating device	Function of the attachment
1	Horizontal rocker button + shift button "F"	Release/open clamp

 **NOTE**

The 5th hydraulic function can be used to control an attachment. The pictograms on the joystick 4Plus show which attachment functions can be controlled using the 5th function.

- For attachments that are controlled using the 5th hydraulic function, the procedures for operation are as follows: ▷

- Press and hold shift key "F"(1) on the joystick 4Plus.
- Simultaneously actuate the horizontal rocker switch (2) in the direction shown in the pictogram so that the attachment moves accordingly.

 **NOTE**

The pictograms on the joystick 4Plus are attached according to the attachments fitted to this truck at the factory. If an attachment with other functions is fitted, the pictograms must be checked for the correct representation and changed if necessary.

- Contact the authorised service centre if required.

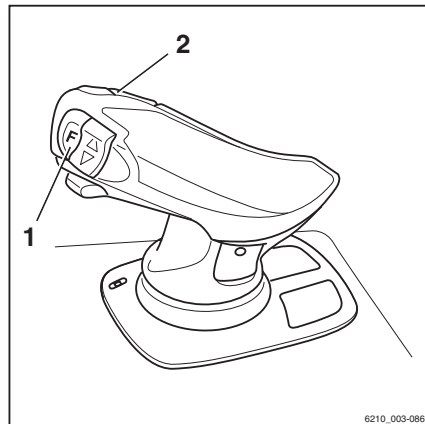
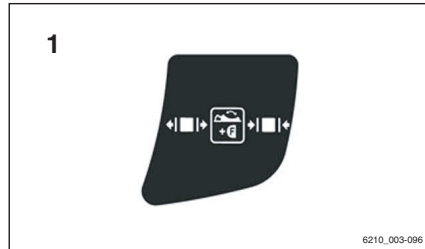

### Controlling the attachments with the fingertip ▷

The attachments (variant) are controlled in this version using the operating levers (1).

The pictograms on the operating levers show the functions that are activated by that lever.

- Move the operating lever (1) forwards

The attachment moves in the direction of movement shown in the upper part of the pictogram.

- Move the operating lever (1) backwards

The attachment moves in the direction of movement shown in the lower part of the pictogram.

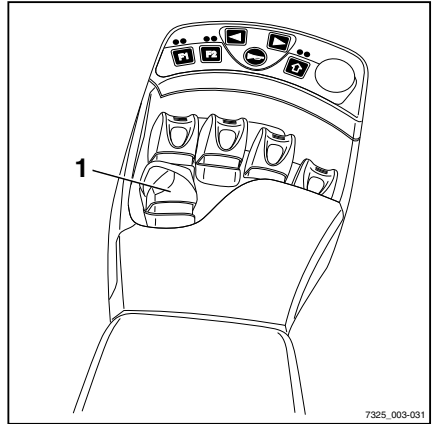

### **i** NOTE

*The pictograms are attached depending on the pre-assembled attachment. If an attachment with other functions is fitted, the pictograms must be checked for the correct representation and changed if necessary.*

- Contact the authorised service centre if required.
- Note the following attachment functions and pictograms! ▷

2	Move side shift frame or fork forwards/backwards
3	Move sideshift to the left/right
4	Adjust fork arms: open/close
5	Swivel lift mast or fork to the left/right
6	Release/clamp load retainer
7	Push off/pull in load
8	Open/close clamps
9	Turn to the left/right
10	Tip shovel over/tip shovel back

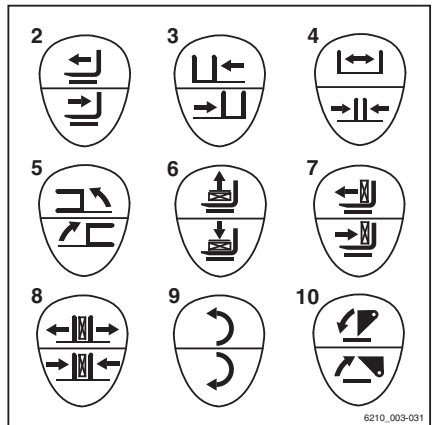

## Working with attachments

## Controlling attachments with the fingertip and 5th function

### NOTE

*The designation "5th function" refers to the fact that the four operating levers control four functions, while the "5th function" can be controlled by switching functions.*

The attachments (variant) are controlled using the operating levers (1).

You can also use the switch (2) to switch functions, in which case the corresponding operating lever controls the "5th function".

The upper and lower parts of the pictogram (3) behind the operating lever show the function that is activated with this lever.

This essentially involves the following:

- Move the operating lever forwards

The attachment moves in the direction of movement shown in the upper part of the pictogram.

- Move the operating lever backwards

The attachment moves in the direction of movement shown in the lower part of the pictogram.

- Actuate the switch (2)

The additional function of the attachment is activated/deactivated and can be controlled as the "5th function" using the operating lever.

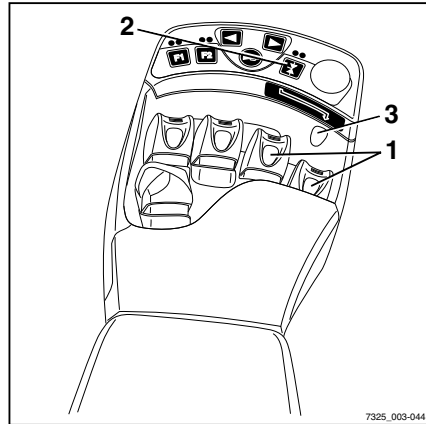

- Press function key (4)

**i** NOTE

*The arrow (5) under the function key indicates which operating lever is equipped with the "5th function".*

The "5th function" is switched to the 3rd operating lever; see sticker (6).

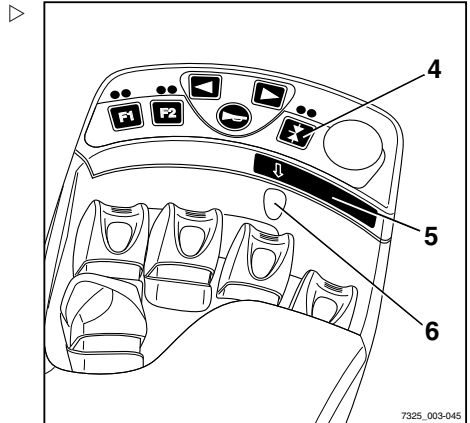

- Press function key (7)

**i** NOTE

*The arrow (8) under the function key indicates which operating lever is equipped with the "5th function".*

The "5th function" is switched to the 4th operating lever; see sticker (9).

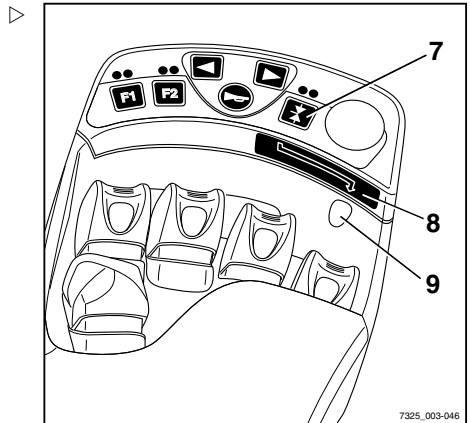

**i** NOTE

*The movement/action of this "5th function" can be found in the operating instructions of the fitted attachment.*

**i** NOTE

*The pictograms are attached depending on the pre-assembled attachment. If an attachment with other functions is fitted, the pictograms must be checked for the correct representation and changed if necessary.*

- Contact the authorised service centre if required.

## Working with attachments

- Note the following attachment functions and pictograms! ▷

10	Move side shift frame or fork forwards/backwards
11	Move sideshift to the left/right
12	Adjust fork arms: open/close
13	Swivel lift mast or fork to the left/right
14	Release/clamp load retainer
15	Push off/pull in load
16	Open/close clamps
17	Turn to the left/right
18	Tip shovel over/tip shovel back

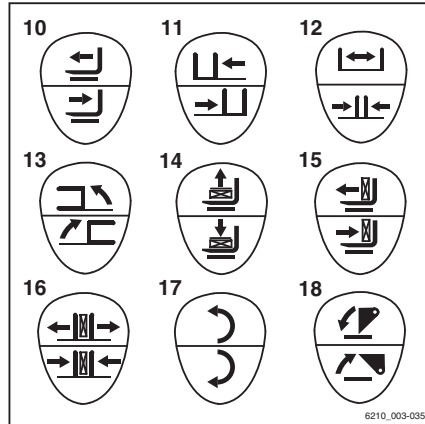

### Clamp locking mechanism (variant)

This truck can be fitted with a clamp locking mechanism as a variant. This prevents the clamp from opening unintentionally if the operating function is inadvertently triggered.

#### **⚠ DANGER**

**There is a risk of fatal injury from falling loads if the correct function of the clamp locking mechanism is not guaranteed!**

If other attachments are used on this truck in addition to the clamp, make sure that the clamp locking mechanism function is reassigned to the corresponding operating device every time the clamp is reassembled; see the chapter entitled "Fitting attachments".

- Make sure that the additional clamp locking mechanism function is available.



### Double mini-lever

- To release the clamp locking mechanism, push the cross lever (1) forwards.

The LED for button F2 (2) lights up as long as the clamp locking mechanism is released.

**i** **NOTE**

*The hydraulic function for opening the clamp is available for one second after the clamp locking mechanism is released. After one second, the clamp locking mechanism is automatically reactivated.*

- To open the clamp, push the cross lever (1) forwards again.

It is not necessary to release the clamp locking mechanism in order to close the clamp.

- To close the clamp, pull the cross lever (1) back.
- To operate clamping attachments, see the section entitled "Controlling attachments using the double mini-lever and the 5th function".

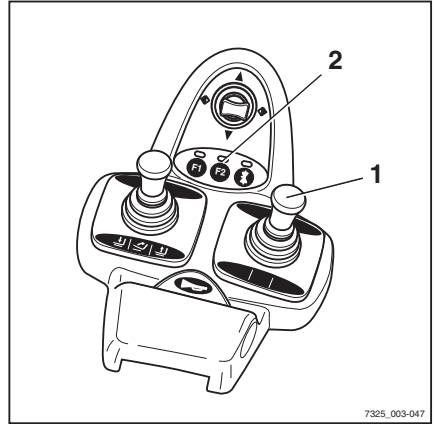

### Triple mini-lever

- To release the clamp locking mechanism, push the operating lever (1) forwards.

The LED for button F2 (2) lights up as long as the clamp locking mechanism is released.

**i** **NOTE**

*The hydraulic function for opening the clamp is available for one second after the clamp locking mechanism is released. After one second, the clamp locking mechanism is automatically reactivated.*

- To open the clamp, push the operating lever (1) forwards again.

It is not necessary to release the clamp locking mechanism in order to close the clamp.

- To close the clamp, pull the operating lever (1) back.

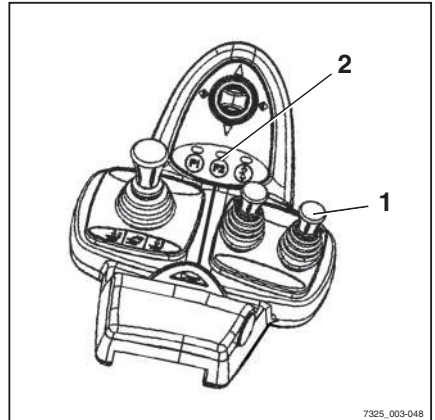

## Working with attachments

- To operate clamping attachments, see the section entitled "Controlling attachments using the triple mini-lever and the 5th function".

### Quadruple mini-lever

- To release the clamp locking mechanism, push the operating lever (1) forwards.

The LED for button F2 (2) lights up as long as the clamp locking mechanism is released.

#### NOTE

*The hydraulic function for opening the clamp is available for one second after the clamp locking mechanism is released. After one second, the clamp locking mechanism is automatically reactivated.*

- To open the clamp, push the operating lever (1) forwards again.

It is not necessary to release the clamp locking mechanism in order to close the clamp.

- To close the clamp, pull the operating lever (1) back.
- To operate clamping attachments, see the section entitled "Controlling attachments using the quadruple mini-lever and the 5th function".

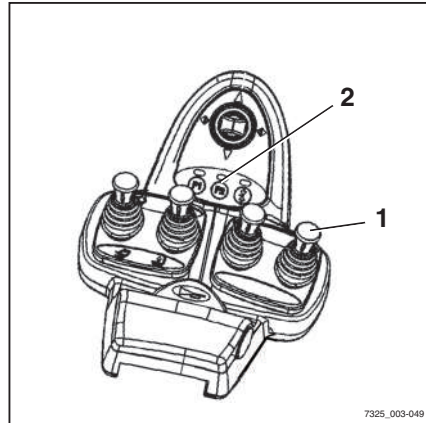

### Joystick 4Plus

- To release the clamp locking mechanism, press and hold shift key "F"(3) and move the horizontal rocker button (1) to the right.
- Keep shift key "F"(3) pressed and move the horizontal rocker button (1) back to the neutral position.

The LED (2) lights up as long as the clamp locking mechanism is released.

- To open the clamp, press and hold shift key "F"(3) and move the horizontal rocker button (1) to the right.



#### NOTE

*The hydraulic function for opening the clamp is available for one second after the clamp locking mechanism is released. After one second, the clamp locking mechanism is automatically reactivated.*

It is not necessary to release the clamp locking mechanism in order to close the clamp.

- To close the clamp, press and hold shift key F (3) and move the horizontal rocker button (1) to the left.
- To operate the clamping attachments, see the section entitled "Controlling attachments using the joystick 4Plus and the 5th function".

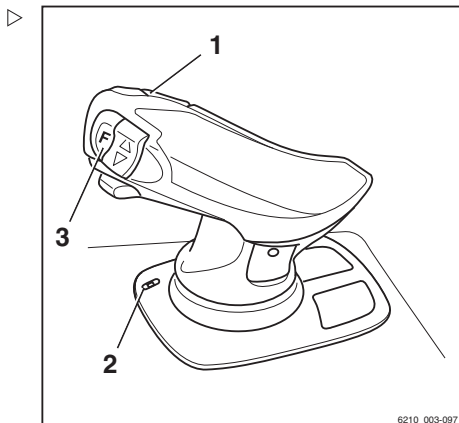

## Working with attachments

### Fingertip switch

- To release the clamp locking mechanism, push the operating lever (1) forwards.

The LED for button F2 (2) lights up as long as the clamp locking mechanism is released.

#### NOTE

*The hydraulic function for opening the clamp is available for one second after the clamp locking mechanism is released. After one second, the clamp locking mechanism is automatically reactivated.*

- To open the clamp, push the operating lever (1) forwards again.

It is not necessary to release the clamp locking mechanism in order to close the clamp.

- To close the clamp, pull the operating lever (1) back.
- To operate the clamping attachments; see the section entitled "Controlling attachments using the fingertip and the 5th function".

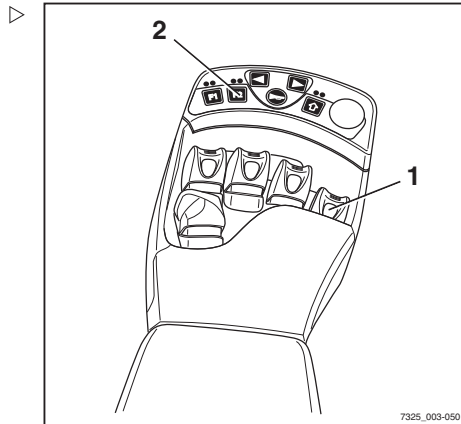

### Taking up a load using attachments

#### WARNING

Risk of accidents!

Attachments may only be used for their intended purpose as described in the relevant operating instructions.

Drivers must be instructed in the handling of the attachments.

#### WARNING

Risk of accidents!

Loads may only be picked up and transported with attachments if they are securely attached. Where necessary, loads should also be secured against slipping, rolling, falling over, swinging or tipping over. Note that any change to the position of the load's centre of gravity will affect the stability of the forklift truck.

Check the capacity rating plates for the attachments or combination of attachments.

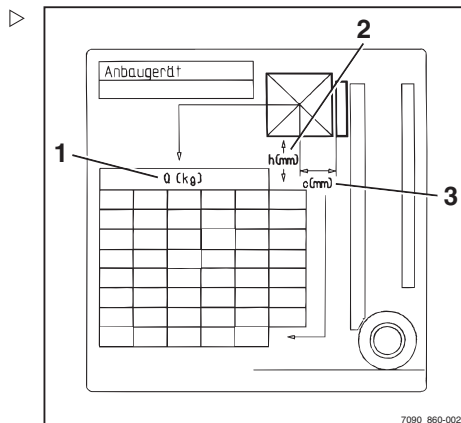

- The rating plates show the permissible values for:
  - Load capacity Q (kg) (1)
  - Lift height h (mm) (2)
  - Load distance C (mm) (3)

## Operating auxiliary equipment

### Switching the lighting on and off

#### Driving lights

- To switch on the parking light, press the button (1). ▷

The front sidelights and the rear lights light up. On the variant with StVZO (German Road Traffic Licensing Regulations) equipment, the licence plate lamp also lights up.

- To switch on the headlights, press the button (1) again.

The headlights light up in addition to the parking light.

- To switch off the driving lights, press the button (1) again.

The driving lights go out.

#### NOTE

*On the version with StVZO (German Road Traffic Licensing Regulations) equipment, the parking light and the licence plate lamp can be switched on without the key switch being switched on.*

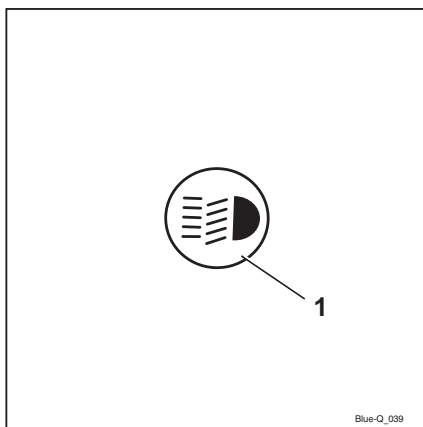

## Operating auxiliary equipment

### Working spotlights

- To switch on the working spotlights (front and rear), press the button (1).

The working spotlights light up.

- To switch off the working spotlights, press the button (1) again.

The working spotlights go out.

#### NOTE

*On the version with StVZO (German Road Traffic Licensing Regulations) equipment, the parking light and the licence plate lamp are switched on by switching on the working spotlights.*

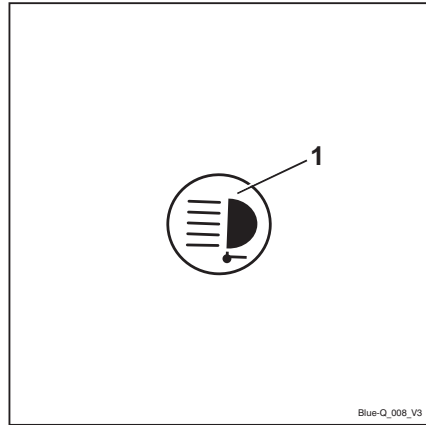

### Switching the rotating beacon on and off

- Push the button (1) for switching on the rotating beacon.

The rotating beacon symbol (2) appears on the display. The rotating beacon is switched on.

#### NOTE

*Pushing the button again switches the rotating beacon off again.*

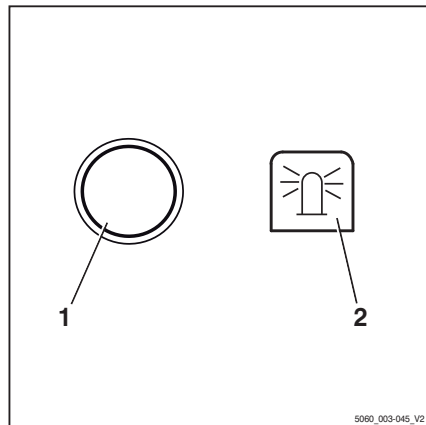

### Switching the hazard warning system on and off

- Push the button (1) to switch on the hazard warning system.

All direction indicators and indicator lights (2) flash.

**i** NOTE

*Pushing the button again switches the hazard warning system off again.*

**i** NOTE

*The hazard warning system can also be switched on without the key switch being switched on.*

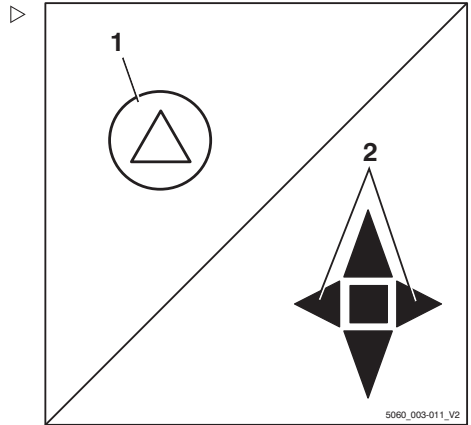

### Switching the direction indicators on and off

#### Mini-lever version

- Switch on the direction indicators by moving the drive direction/turn indicator cross lever (1) to the left or right.

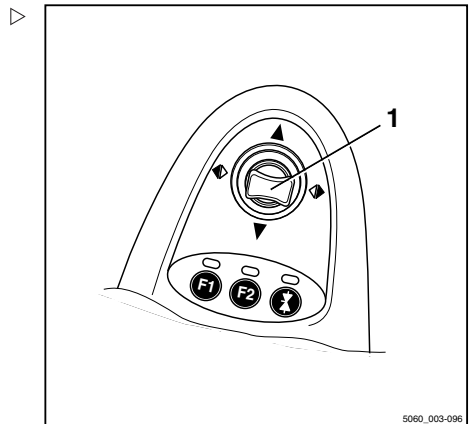

## Operating auxiliary equipment

The direction indicators and the corresponding direction indicator lights (2) or (3) flash. ▷

- Switch off the direction indicators by moving the cross lever to the centre position

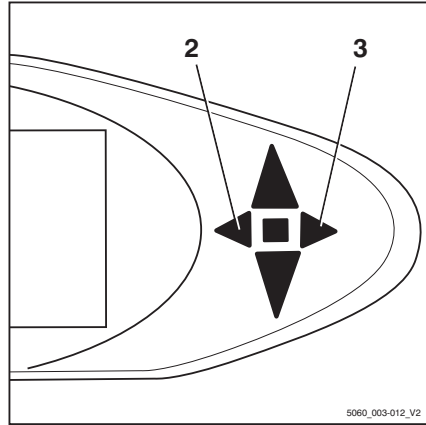

## Mini-console version

- Switch on the direction indicators by moving the turn indicator switch (1) to the left or to the right. ▷

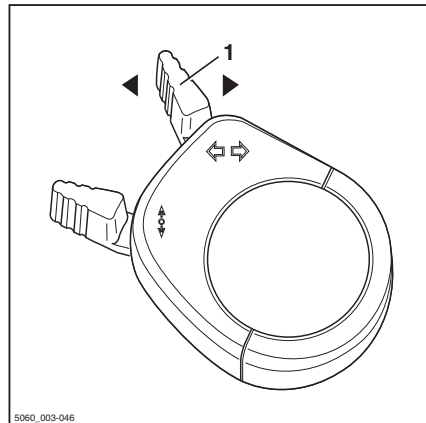



The direction indicators and the corresponding direction indicator lights (2) or (3) flash.

- Switch off the direction indicators by moving the turn indicator switch to the centre position

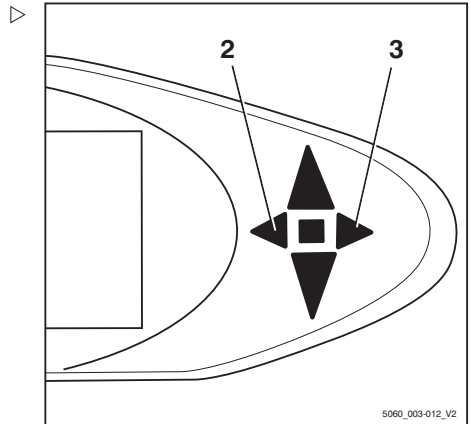

### Switching the double working spotlights on and off.

The double working spotlights are fitted up on the front right and left on the overhead guard. Each double working spotlight consists of an upper working spotlight (2) and a lower working spotlight (3). The upper working spotlight illuminates the working area at great lift heights, the lower working spotlight illuminates the working area directly in front of the truck.

Depending on the equipment, the upper working spotlights can be switched on/off automatically or manually.

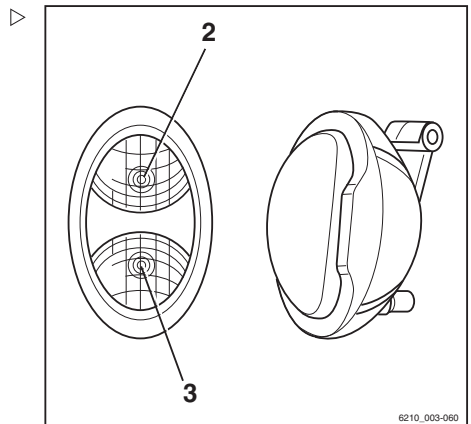

### Switching the upper working spotlights on/off manually

#### **i** NOTE

*The upper working spotlights can be switched on/off independently of the lower working spotlights. For information on switching the lower working spotlights on, see the "Switching lighting on and off" chapter.*

#### **i** NOTE

*This function is not available if the truck is equipped with rear window heating.*

## Operating auxiliary equipment

- Turn the key switch to position "I".
- Press button (1).

### NOTE

*Pressing the button again switches the working spotlights off again.*

### Switching the upper working spotlights on/off automatically

- Turn the key switch to position "I".
- For information on switching on working spotlights, see the "Switching lighting on and off" chapter.

The lower working spotlights light up.

The upper working spotlights are switched on automatically when the lift mast is lifted for a period of at least two seconds.

### NOTE

*In these two seconds, a maximum of two lifts can take place so that the working spotlights do not switch on each time a precise adjustment is made. If more lifts are carried out during this time, the upper working spotlights will remain switched off.*

### NOTE

*The upper working spotlights are switched off automatically when the truck is driven for longer than one second and faster than 2.1 km/h.*

### Lift-height-controlled switching on/off of the upper working spotlights

### NOTE

*This equipment is available only if a proximity switch is fitted to the lift mast to record a particular lift height of the fork carriage on the lift mast.*

- Turn the key switch to position "I".
- Switch on the working spotlights.

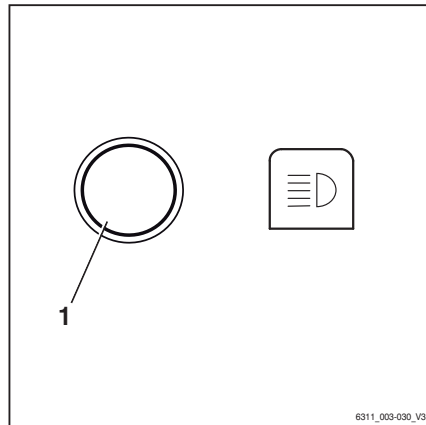

The lower working spotlights light up.

The upper working spotlights are switched on by the proximity switch when the fork carriage reaches or exceeds the preset lift height.

The upper working spotlights are switched off by the proximity switch when the fork carriage falls below the preset lift height again.

### ⚠ CAUTION

Possible component damage caused by collision if the proximity switch is set incorrectly.

- The proximity switch may be adjusted by trained personnel.
- Inform the relevant service centre.

## Operating the windscreen wiper/washer

- Press the button (1) to activate the front wiper/washer (variant) and the roof panel wiper (variant).
- Push button (2) to actuate the rear windscreen wiper/washer (variant).

Repeated pressing of the respective button switches between the operating stages in the sequence shown below.

Button actuation	Operating stage
	Off
1st time	On
2nd time	Interval
3rd time + hold	Washer
4th time	Off

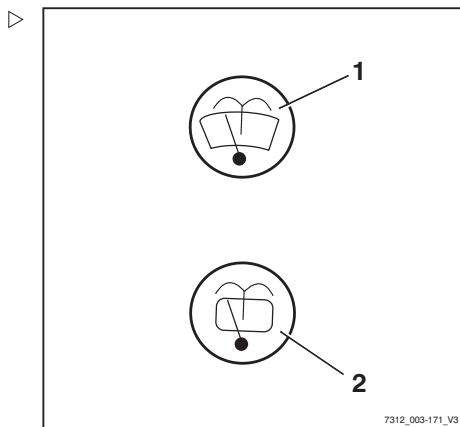

7312\_003-171\_V3

## FleetManager (variant)

FleetManager is an equipment variant and can be fitted to the truck in different versions. The description and operation information can be found in the separate operating instructions for the corresponding FleetManager versions.

## Operating auxiliary equipment

### Accident recorder (variant)

The accident recorder is an equipment variant to the FleetManager (variant), which is installed in the truck's acceleration sensor. The acceleration sensor records data in the event of an accident. This data can be electronically read out and evaluated. For further information, contact your STILL service centre.

### Cruise control (variant)

Using the cruise control function, the driver can save the speed in forwards travel when it is > 6.0 km/h by pressing a button, and continue driving without actuating the accelerator pedal.



#### NOTE

*The cruise control function cannot be used for reverse travel or when travelling at speeds of < 6.0 km/h.*

Depending on the truck equipment, the cruise control can be switched on and off via the drive direction switch or the display and operating unit.

Switching on and off via the drive direction switch (1).

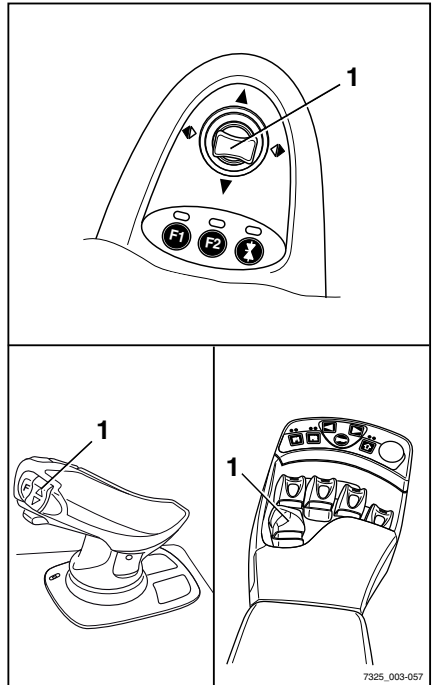

Switching on and off via the display and operating unit.

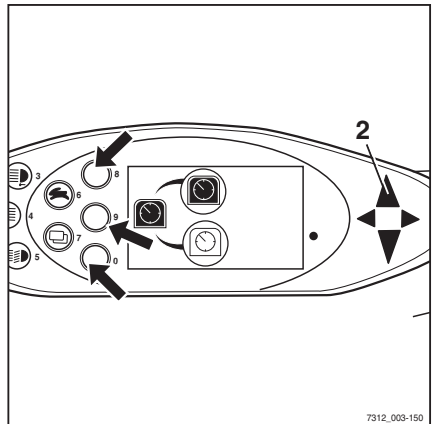

### Switching on cruise control

**⚠ WARNING**

Risk of accident from failing to adjust speed!  
 Driving at excessive speeds can cause accidents, e.g. the truck could tip over when cornering.

- Adjust speed along the entire distance being travelled
- Pay particular attention to cornering speed
- Observe safety regulations when driving
- Observe the special behaviour of the cruise control function and the dangers associated with it

- Start drive mode.
- Accelerate the truck to the required speed (at least 6.0 km/h)

## Operating auxiliary equipment

- Re-actuate the drive direction switch (1) for forward travel for at least one second, or press the corresponding button on the display and operating unit.

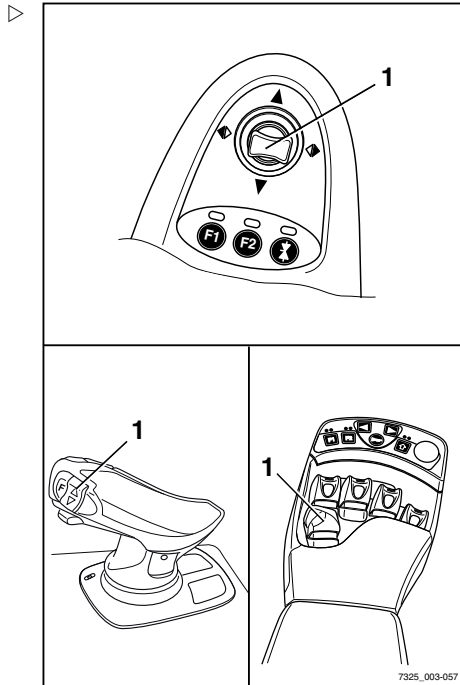

The current speed is saved. The forwards drive direction indicator (2) flashes.

The cruise control symbol on the display and operating unit is shown in black.

- Remove your foot from the accelerator pedal.

The truck continues to drive at the selected speed until the cruise control function is switched off again.

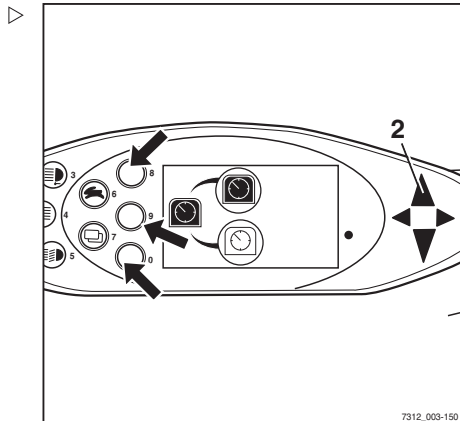

### Switching off cruise control

The cruise control function is switched off by means of one of the following actions:

- Actuate the foot brake
- Actuate the parking brake
- Actuate the accelerator pedal
- Move the drive direction switch (1) into the neutral position or reverse
- Actuate the corresponding button (see arrows, previous picture) on the display and operating unit

**i** NOTE

*If the seat switch is not actuated, the truck's cruise control function and drive function are switched off.*

The accelerator pedal can be used to switch off the cruise control function, depending on which function type is programmed:

- Type 1:  
Even slightly depressing the accelerator pedal switches off the cruise control function
- Type 2:  
To switch off the cruise control function, the accelerator pedal must be depressed at least as far as it was when saving the speed

– Switch off cruise control

The drive direction indicator (2) lights up.

The cruise control symbol on the display and operating unit is shown in white.

**i** NOTE

*If the truck is configured with automatic functions that reduce the driving speed to 6 km/h or less in certain situations, then these functions will also switch the cruise control off automatically.*

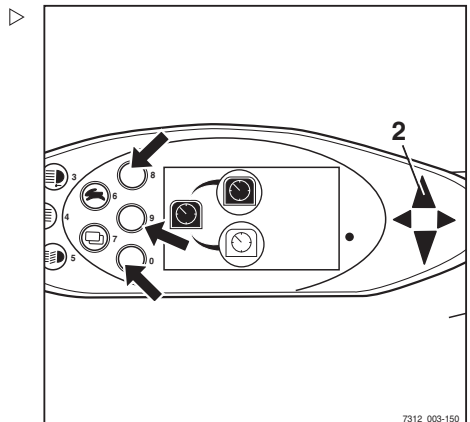
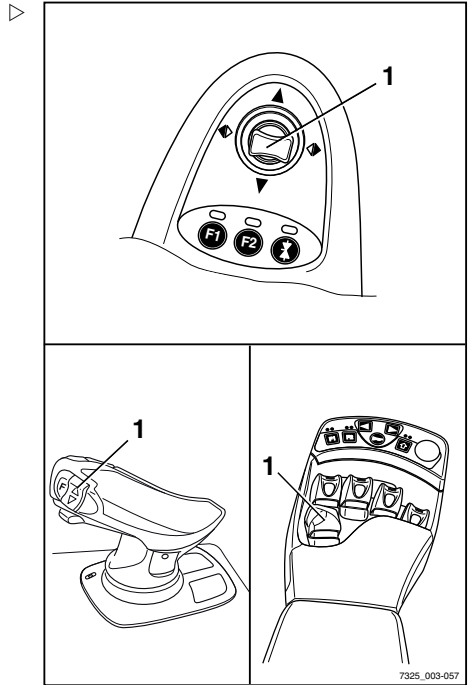

## Cab operation

### Driver restraint systems (variants)

Different driver restraint systems are available as variants for this truck. The description and operation for these systems can be found in the separate "Driver restraint systems" operating instructions.

## Cab operation

### Opening the cab door

#### **⚠ DANGER**

**There is a risk of damage caused by collision if the cab door opens while driving.**

- The cab door must be latched securely in the engaged position.

#### Opening the cab door from the outside:

- Insert the key in the door lock (1), unlock and remove the key.
- Pull the door handle (2) and release the door lock.
- Open the cab door (3) by pulling outwards.

#### Opening the cab door from the inside:

- Take hold of the handlebar (4) and latch (5).
- Press the latch in and push the cab door outwards.

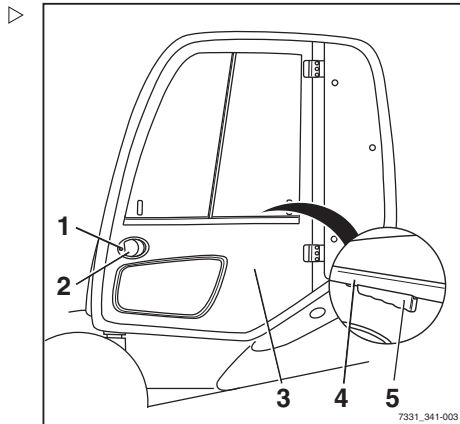



## Closing the cab door

### **⚠ DANGER**

There is a risk of damage caused by collision if the cab door opens while driving.

- The cab door must be latched securely in the engaged position.

## Opening the side windows

### **⚠ WARNING**

There is a risk of crushing between the window frame and side window from the side windows slipping inadvertently during travel.

- Make sure that the handle engages securely in the corresponding stop slot.

### Opening the rear side window:

- Press the handle (2) together and slide the rear side window (1) forwards.
- Make sure that the handle engages in the stop slot (3).

### Opening the front side window:

The front side window (4) can be opened in the same way as the rear side window.

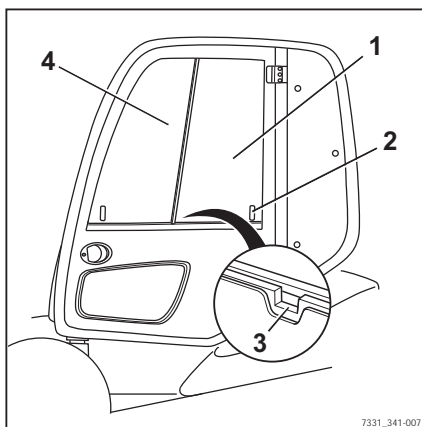

## Cab operation

## Closing the side windows

**⚠ WARNING**

There is a risk of crushing between the window frame and side window from the side windows slipping inadvertently during travel.

- Make sure that the handle engages securely in the corresponding stop slot.

## Closing the rear side window:

- Press the handle (2) together and pull the rear side window (1) to the rear.
- Make sure that the handle engages in the stop slot (3).

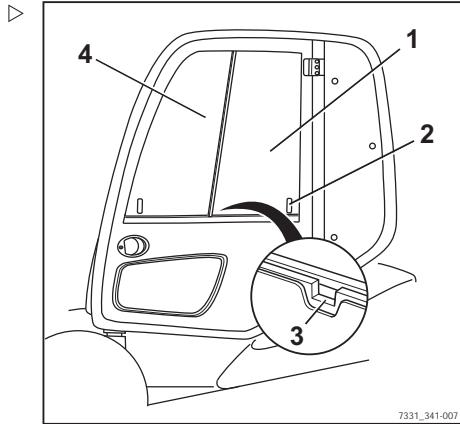

## Closing the front side window:

The front side window (4) can be closed in the same way as the rear side window.

## Operating the interior lighting

An interior light (1) with swivelling support (3) is fitted in the right-hand roof lining of the cab.

The interior lighting can be operated using the switch (2) in the roof lining and via the corresponding soft key button on the display and operating unit.

**i NOTE**

*The interior lighting cannot be switched on using the switch in the roof lining if it has been switched off on the display and operating unit. The interior lighting cannot be switched on at the display and operating unit if the switch in the roof lining is in position "0".*

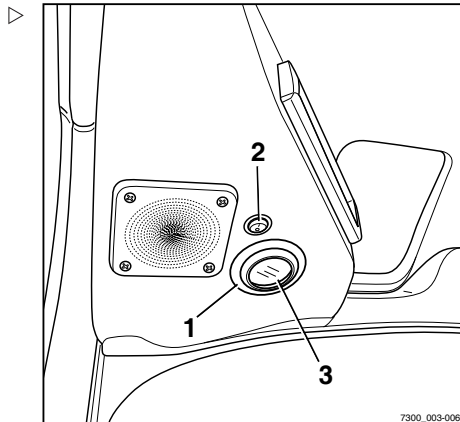

## Switching on the interior lighting

- Check whether the switch in the roof lining is in position "I"; if not, move the switch to position "I".

- Switch on the interior lighting using the corresponding soft key button (1) on the display and operating unit.

The "interior lighting" symbol (2) appears in the display on the display and operating unit.

The interior lighting is switched on.

### Adjusting the beam direction

- To change the beam direction, carefully swivel the support into the required position.

### Switching off the interior lighting

- Switch off the interior lighting using the corresponding soft key button on the display and operating unit.

The "interior lighting" symbol goes out in the display on the display and operating unit.

The interior lighting is switched off.



### NOTE

*We do not recommend that you use the switch in the roof lining to turn off the interior lighting. If the interior lighting is switched off using the switch in the roof lining, both the switch in the roof lining **and** the button on the display and operating unit must always be actuated to switch on the light.*

### Operating the rear window heating

- Switch the rear window heating on or off with button (1).

The "rear window heating" symbol (2) appears in the display.



### NOTE

*The rear window heating will switch off automatically after approx. 10 minutes or after pressing the switch again.*

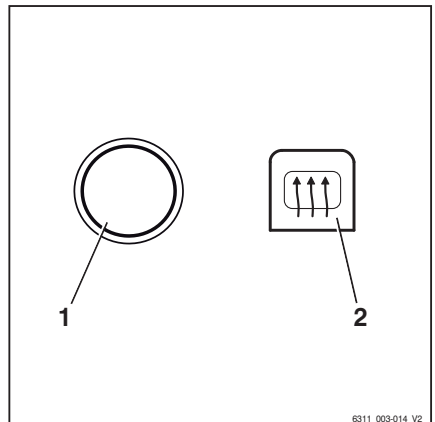
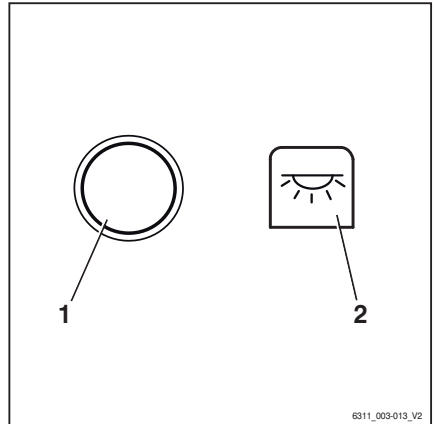

## Cab operation

### Radio (variant)

The radio (1) and the loudspeakers (2) are an equipment variant. If the truck is equipped with a radio and loudspeakers, they are integrated into the roof lining.

The description and operation can be found in the separate operating instructions for the radio.

#### **⚠ WARNING**

The driver's attention is adversely affected by operating the radio or listening to excessive volume while driving or handling loads. There is a risk of accident!

- Do not use the radio when driving or when handling loads.
- Set the radio volume so that you can still hear warning signals.

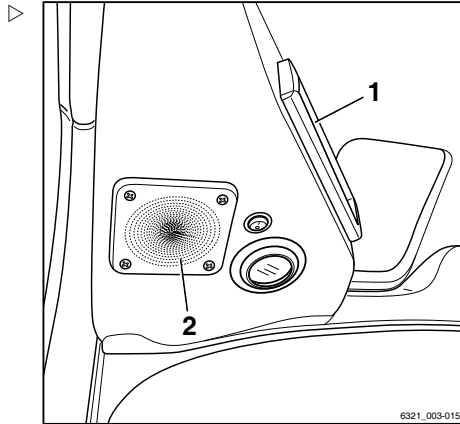

### Heating system (variant)



#### **⚠ DANGER**

##### **Risk of explosion!**

There is a risk of explosion if the heater is operated in the vicinity of storage areas or similar areas where fuel vapours or coal dust, wood dust and crop dust can accumulate.

- Do not expose spray cans or gas cartridges to the flow of hot air.
- Do not operate the heater in hazardous areas.



#### **⚠ DANGER**

##### **Risk of fire as a result of heat building up in the heating element!**

Heat may build up if the air intake opening is blocked or the heating element collects dust. The heating element may overheat or short-circuit.

- Do not cover the air intake opening.
- Do not operate the heating system without a fresh air filter and recirculated air filter fitted.



### **⚠ DANGER**

#### **Risk of burns!**

When the heating system is operated, the heating system housing becomes hot and can burn the skin if it is touched.

- Do not touch the heating system housing during operation.

### **⚠ CAUTION**

#### **Risk of blower malfunction!**

The fresh air filter and recirculated air filter collect dust and dirt particles from the intake air. If the filter elements are not fitted, dust and dirt particles may block the blower.

- Do not operate the blower without a fresh air filter and recirculated air filter fitted.

### **Switching on the blower**

- To switch on the blower, turn on the blower switch (1).

The blower runs at the speed level set at the switch.

### **Switching on the heating system**

#### **i NOTE**

*The heating system only heats up when the blower is switched on. If the blower switch is switched off, the heating system will not function, regardless of the position of the heater switch.*

- To switch the heating system on, first switch on the blower switch (1) and then the heating switch (2).

The heating system is in operation. The air is heated up to the heat output level set at the heating switch (2).

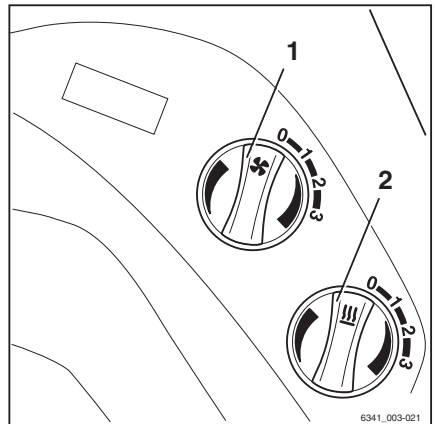

## Cab operation

**Adjusting the air flow**

- Adjust the air flow at the front outlet vents (3) and at the outlet vent in the footwell (4).

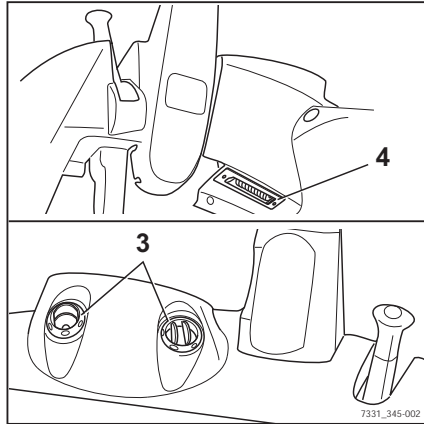
**Air conditioning (variant)****Switching on the air conditioning**

- Switch the blower switch (1) on.
- Set the cryostat (2) to the desired level.
- Switch on the air conditioning by pressing the switch (3).

**Switching off the air conditioning**

- Switch off the air conditioning by pressing the switch (3).
- Switch off the blower switch (1).

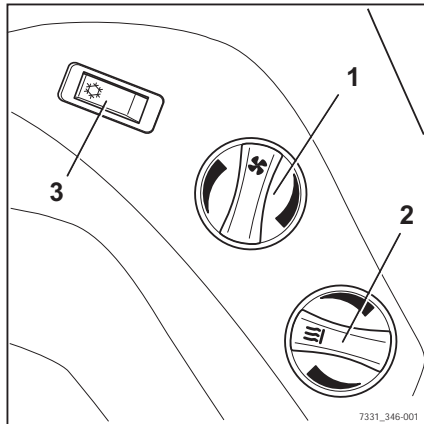

## Push-up roof window (variant)

### ⚠ WARNING

Risk of crushing!

- When closing the roof window, do not reach between the roof window and the overhead guard.
- Do not reach in to touch components as they are being closed.

The push-up roof window (1) is an equipment variant.

- To unlock and open the roof window, rotate the handle (2) in an anti-clockwise direction and use it to push the roof window upwards.

The roof window is held in the open position by means of gas springs (3).

- To close and lock the roof window, pull the roof window downwards using the handle and rotate the handle in a clockwise direction

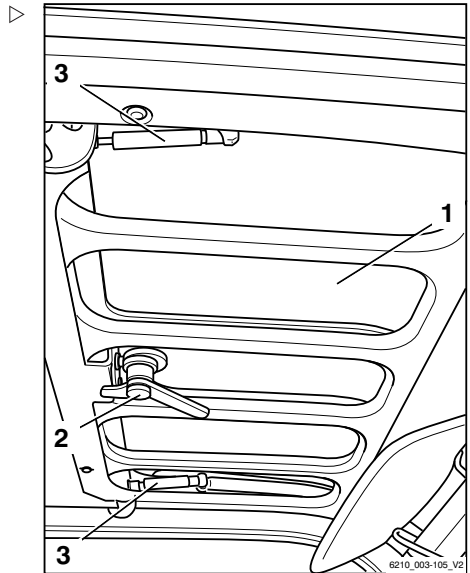

## Clipboard (variant)

The clipboard (1) with reading lamp (2) is an equipment variant.

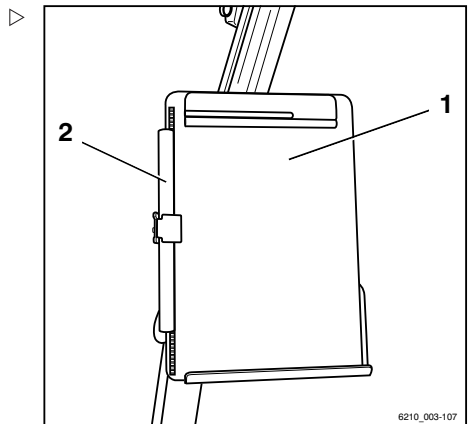

## Trailer operation

## Trailer operation

## Towed load

**⚠ DANGER**

**There is an increased risk of accident when using a trailer.**

Using a trailer changes the truck handling characteristics. When towing, operate the truck such that the trailer train can be safely driven and braked at all times. The maximum permissible speed when towing is 5 km/h.

- Do not exceed the permissible speed of 5 km/h.
- Do not couple the truck in front of rail vehicles.
- The truck must not be used to push any kind of trolley.
- It must be possible to drive and brake at all times.

**⚠ CAUTION**

Risk of damage to components!

The maximum towed load for occasional towing is the rated capacity specified on the nameplate. Overloading can lead to component damage on the truck. The sum of the actual towed load and the actual load on the fork must not exceed the rated capacity. If the towed load present corresponds to the rated capacity of the truck, it is not permitted to transport a load on the fork at the same time. The load can be distributed between the fork and the trailer.

- Check the load distribution and adjust to correspond to the rated capacity.
- Observe the permissible rigidity value of the tow coupling.

**⚠ CAUTION**

Risk of damage to components!

The maximum towed load only applies when towing unbraked trailers on a level surface (maximum deviation +/- 1%) and on firm ground. The towed load must be reduced if towing on gradients. If necessary, notify the authorised service centre of the application conditions. The service centre provides the required data.

- Inform the authorised service centre.

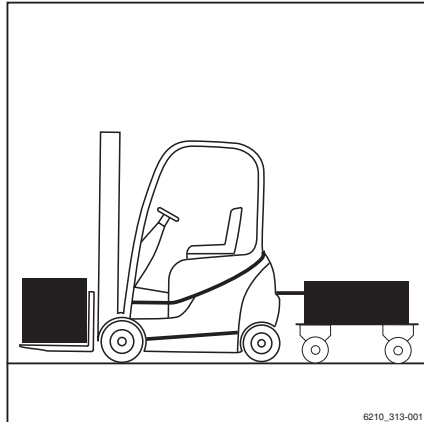

6210\_313-001



**⚠ CAUTION**

Damage to the tow coupling due to overloading!

Tow couplings RO\*243 and RO\*244 must be individually checked to ensure that they are suitable for the planned towing operation. The permissible rigidity value of the tow coupling must always be taken into account. The authorised service centre can check and/or confirm the maximum towed load for the planned towing operation.

- Observe the operating instructions for the tow coupling.
- Inform the authorised service centre.

**⚠ CAUTION**

Risk of damage to components!

A support load is not permitted.

- Do not use trailers with tillers supported by the tow coupling.

This truck is suitable for the occasional towing of trailers. If the truck is equipped with a towing device, this occasional towing must not exceed 2% of the daily operating time. The manufacturer must be consulted if the truck is to be used for towing on a more regular basis.

## Coupling pin in the counterweight

### Coupling the trailer

**⚠ DANGER**

**If you briefly leave the truck to couple or uncouple, there is a risk to life caused by the truck rolling away and running you over.**

- Apply the parking brake.
- Lower the fork to the ground.
- Turn off the key switch and remove the key.

## Trailer operation

- Take measures to prevent the trailer from rolling away, e.g. use wheel chocks (1).

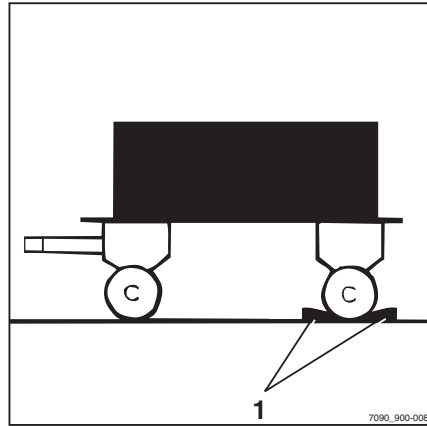

- Push the coupling pin (2) down, turn 90° and pull out.
- Adjust tiller height.

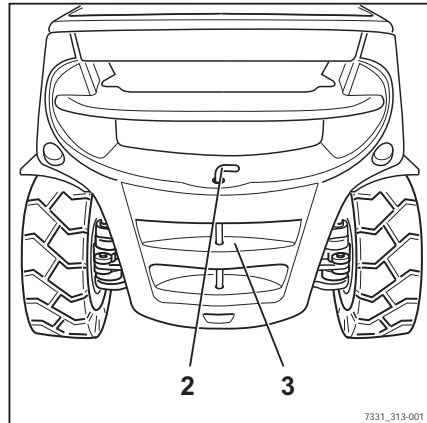
**⚠ DANGER**

**Persons may become trapped between the truck and trailer.**

When hooking up, ensure that no one is between the truck and trailer.

- Slowly move the truck back.
- By moving the truck back, introduce the tiller into the gap (3) of the counterweight.

**⚠ DANGER**

**In the event of loss or destruction of the coupling pin or the securing bush during towing, the trailer works loose and becomes uncontrollable, meaning there is a risk of accident!**

- Use only original coupling pins that have been checked for good condition.
  - Ensure that the coupling pin is correctly inserted and secured.
- 
- Insert the coupling pin into the counterweight, press downwards against the spring pressure and turn 90° (the coupling pin is locked in this position).
  - Remove any items used to prevent the trailer from rolling away.

### Uncoupling the trailer

- Take measures to prevent the trailer from rolling away, e.g. use wheel chocks.
- Push the coupling pin (2) down, turn 90° and pull out.
- Slowly move the truck forwards and guide the tow-bar eye completely out of the counterweight.
- Insert the coupling pin into the counterweight, press downwards against the spring pressure and turn 90° (the coupling pin is locked in this position).

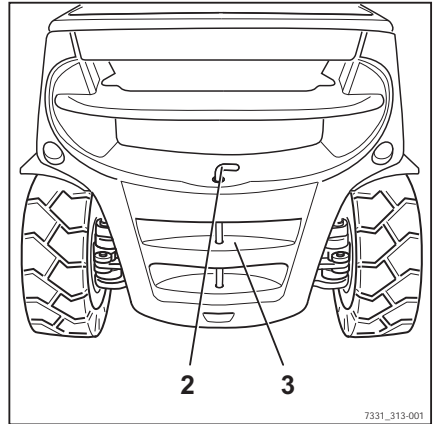

7331\_313-001

### Automatic tow coupling

#### **⚠ DANGER**

**Persons may become trapped between the truck and trailer.**

When hooking up, ensure that no one is between the truck and trailer.

#### **⚠ DANGER**

**Never jack up or crane load the truck on the tow coupling. The tow coupling is not designed for this and could be deformed or destroyed. The truck could fall off, with potentially fatal consequences!**

- Use the tow coupling only for towing.
- For jacking up and crane loading, use only the designated lifting points.

#### **⚠ DANGER**

**The tow coupling is not designed for support loads and could be deformed or destroyed. This could cause the supported load to fall, with potentially fatal consequences!**

- The tow coupling should be subjected only to horizontal loads, i.e. the tiller must be horizontal.

## Trailer operation

### DANGER

**If you briefly leave the truck to couple or uncouple, there is a risk to life caused by the truck rolling away and running you over.**

- Apply the parking brake.
- Lower the fork to the ground.
- Turn off the key switch and remove the key.

### WARNING

Never reach between the coupling pins and the towing jaws. If the component moves suddenly there is a risk of injury!

- To release the coupling pin, actuate the corresponding lever or use a suitable device (e.g. assembly lever).
- When not in use, close the automatic tow coupling.

### CAUTION

Risk of damage due to component collision.

A truck with tow coupling needs more room for manoeuvring due to its overhang. The tow coupling can damage the racking or the tow coupling itself when manoeuvring. If there is a collision with the tow coupling, check the tow coupling for damage such as cracks. A damaged tow coupling must not be used again.

- Always manoeuvre carefully and with sufficient room.
- In the case of a collision, check the tow coupling for damage.
- Replace tow coupling if damaged, if necessary contact the authorised service centre.

### CAUTION

Risk of damage to the tow bar eye or tiller!

Due to the truck's rear wheel steering, the side slewing angle of the tiller may not be adequate. The coupling or the tiller may be damaged! The tow bar eye of the tiller must fit the tow coupling in terms of shape and size.

- Ensure that the tow bar eye and tiller fit correctly.
- Avoid sharp cornering.
- Exercise care when travelling and manoeuvring in reverse.

**⚠ CAUTION**

Risk of component damage if the tiller in the tow coupling is tilted!

The tiller should if possible be kept horizontal when towing. This ensures a sufficient rotation range at the top and bottom. The authorised service centre can adjust the assembly height for the tow coupling to the tiller height if necessary.

- Make sure that the tiller is level.
- To change the coupling height, contact the authorised service centre.

**Coupling model RO\*243****⚠ CAUTION**

Damage to the tow coupling due to overloading!

Tow couplings RO\*243 and RO\*244 must be individually checked to ensure that they are suitable for the planned towing operation. The permissible rigidity value of the tow coupling must always be taken into account. The authorised service centre can check and/or confirm the maximum towed load for the planned towing operation.

- Observe the operating instructions for the tow coupling.
- Inform the authorised service centre.

**i NOTE**

*Tow coupling RO\*243 is intended for a tow-bar eye in accordance with DIN 74054 (bore diameter 40 mm).*

- Take measures to prevent the trailer from rolling away, e.g. use wheel chocks (1).
- Adjust the tow bar eye of the tiller so that it is at the centre of the towing jaws.

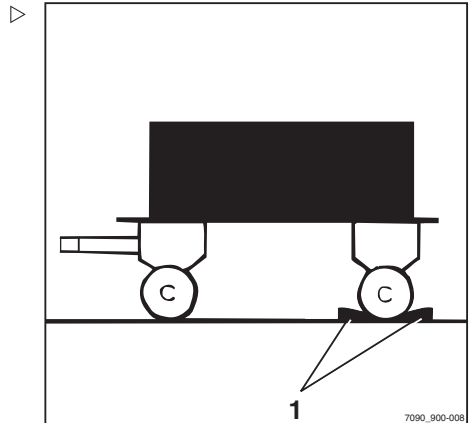

## Trailer operation

- Pull out the safety handle (3).
- Push the hand lever (2) upwards.

### **⚠ DANGER**

**Persons may become trapped between the truck and trailer.**

When hooking up, ensure that no one is between the truck and trailer.

### **⚠ CAUTION**

When being coupled, the tow-bar eye must engage in the middle of the coupling jaw. Failure to follow these instructions could result in damage to the coupling jaw or to the tow-bar eye!

- Ensure that the tow-bar eye enters the coupling jaw centrally.
- Slowly move the truck back.

### **⚠ DANGER**

**If the coupling pin drops out during towing, the trailer will work loose and can no longer be controlled. There is a risk of accident!**

A protruding safety handle means that the tow bar eye has not been coupled correctly. The trailer must not be towed in this condition.

- Ensure that the safety handle is flush with the securing bush.
- If the safety handle protrudes, repeat the coupling process.
- Remove any items used to prevent the trailer from rolling away.
- Tow the trailer.

## Closing model RO\*243 by hand

### **⚠ DANGER**

**Risk of injury from hand becoming trapped!**

Do not reach into the coupling pin area with your hand. If, for example, a tow rope is to be secured in the tow coupling, use only a suitable device to close the tow coupling (e.g. assembly lever).

- Use a suitable device (e.g. assembly lever) to push the coupling pin up.

The coupling pin is released from the latch and then closes the tow coupling automatically.

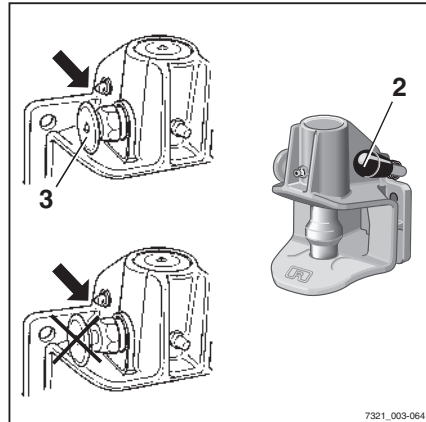

### Uncoupling model RO\*243

- Take measures to prevent the trailer from rolling away, e.g. use wheel chocks.
- Pull out the safety handle (3).
- Push the hand lever (2) upwards.
- Slowly drive the truck forwards until the tow-bar eye and towing jaws are disconnected.
- Close the tow coupling by hand.

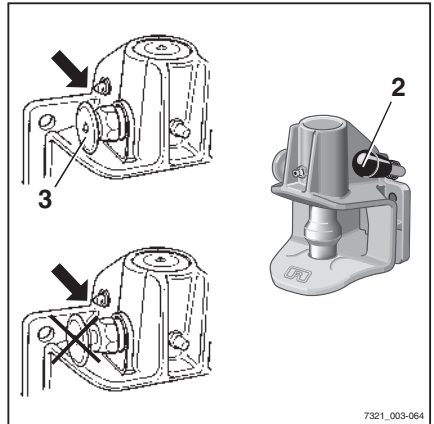

### Coupling model RO\*244 A

#### ⚠ CAUTION

Damage to the tow coupling due to overloading!  
Tow couplings RO\*243 and RO\*244 must be individually checked to ensure that they are suitable for the planned towing operation. The permissible rigidity value of the tow coupling must always be taken into account. The authorised service centre can check and/or confirm the maximum towed load for the planned towing operation.

- Observe the operating instructions for the tow coupling.
- Inform the authorised service centre.

#### **i** NOTE

*Tow coupling RO\*244 A is intended for a tow-bar eye in accordance with DIN 74054 (bore diameter 40 mm) or DIN 8454 (bore diameter 35 mm).*

- Take measures to prevent the trailer from rolling away, e.g. use wheel chocks.
- Adjust the tow bar eye of the tiller so that it is at the centre of the towing jaws.
- Push the hand lever (2) upwards until it snaps into place.

The tow coupling is opened.

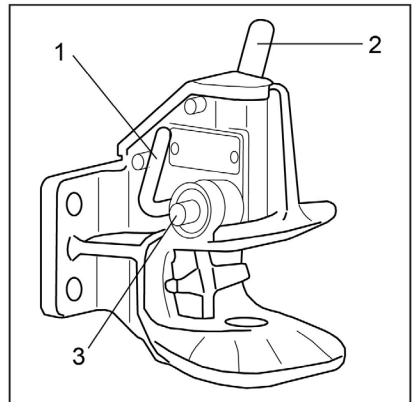

## Trailer operation

**⚠ DANGER****Persons may become trapped between the truck and trailer!**

When hooking up, ensure that no one is between the truck and trailer.

**⚠ CAUTION**

When being coupled, the tow-bar eye must engage in the middle of the coupling jaw. Failure to follow these instructions could result in damage to the coupling jaw or to the tow-bar eye!

- Ensure that the tow-bar eye enters the coupling jaw centrally.
- Move the truck back slowly until the tow bar eye is inserted centrally into the coupling jaw of the tow coupling and the coupling pin engages.

**NOTE**

*The coupling pin is correctly engaged if the control pin (3) does **not** protrude out of its guide.*

**⚠ DANGER****If the coupling pin drops out during towing, the trailer will work loose and can no longer be controlled. There is a risk of accident!**

The control pin (3) must **not** protrude out of its guide.

- Ensure that the coupling pin is engaged correctly.
- If the coupling pin is not correctly engaged:
  - Remove any items used to prevent the trailer from rolling away.
  - Move the truck with the trailer forwards approx. 1 m and then move it back slightly.
  - On the coupling pin, check again that the control pin **does not** protrude out of its guide.

- Remove any items used to prevent the trailer from rolling away.
- Tow the trailer.



### Closing model RO\*244 A by hand

#### **⚠ DANGER**

#### **Risk of injury from hand becoming trapped!**

Do not reach into the coupling pin area with your hand. If, for example, a tow rope is to be secured in the tow coupling, only actuate the tow coupling via the closing lever (1).

- Press the closing lever (1) downwards as far as it will go.

The tow coupling is closed.

### Uncoupling model RO\*244 A

- Take measures to prevent the trailer from rolling away, e.g. use wheel chocks.
- Push the hand lever (2) upwards until it snaps into place.

The tow coupling is opened.

- Slowly drive the truck forwards until the tow-bar eye and towing jaws are disconnected.
- Close the tow coupling by actuating the closing lever (1).

#### **i NOTE**

*To protect the lower coupling pin bush against contamination, always keep the tow coupling closed.*

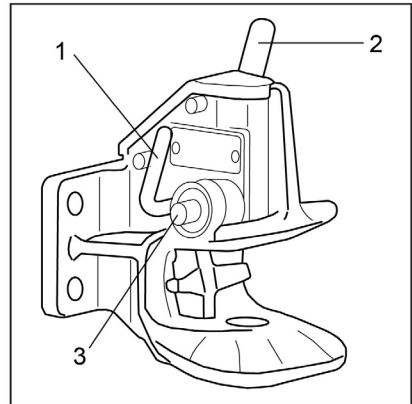

## Trailer operation

## Coupling model RO\*245

 NOTE

Tow coupling RO 245 is intended for a tow-bar eye in accordance with DIN 74054 (bore diameter 40 mm) or DIN 8454 (bore diameter 35 mm).

- Take measures to prevent the trailer from rolling away, e.g. use wheel chocks.
- Adjust the tow bar eye of the tiller so that it is at the centre of the towing jaws.
- Push the hand lever (5) upwards.

The tow coupling is opened.

 DANGER**Persons may become trapped between the truck and trailer!**

When hooking up, ensure that no one is between the truck and trailer.

- Slowly move the truck back.

 DANGER**If the coupling pin drops out during towing, the trailer will work loose and can no longer be controlled. There is a risk of accident!**

A protruding safety handle means that the tow bar eye has not been coupled correctly. The trailer must not be towed in this condition.

- Make sure that the control pin does **not** protrude from the control bush.
  - Repeat the coupling process if necessary.
- 
- Remove any items used to prevent the trailer from rolling away.
  - Tow the trailer.

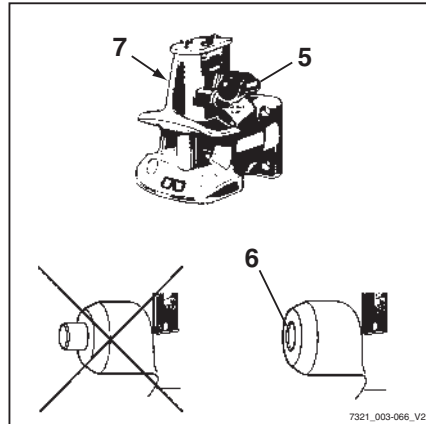

7321\_003-066\_V2

### Uncoupling model RO\*245

- Take measures to prevent the trailer from rolling away, e.g. use wheel chocks.
- Push the hand lever (5) upwards.
- Slowly drive the truck forwards until the tow-bar eye and towing jaws are disconnected.
- Push the closing lever (7) on the left side of the tow coupling down as far as it will go.

The tow coupling is closed.

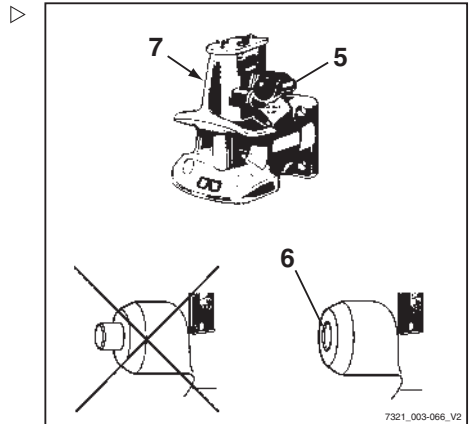

### Towing trailers

- Drivers who are towing a trailer for the first time must practise driving with a trailer in a suitable area.
- When passing through narrow road areas (entrances, gates etc.), observe the dimensions of the trailer and load.
- When towing multiple trailers, ensure a sufficient minimum distance to fixed installations when turning and cornering.

The permissible length of the trailer trains depends on the roadways to be driven and may need to be determined during the test drive.

It is the responsibility of the operating company to instruct the drivers regarding the permissible number of trailers and, where required, any additional speed reductions on individual sections of the route.

#### NOTE

*Please observe the definition of the following responsible persons: "operating company" and "driver".*

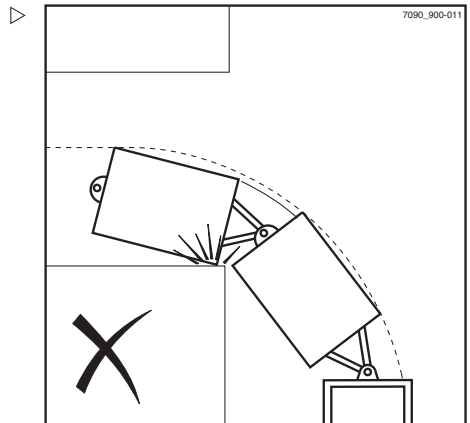

## Operating the display and operating unit

### Operating the display and operating unit

#### Displays

##### Standard display elements

In the factory setting, the following indicators can be seen in the display and operating unit:

- 1 **Fuel level**  
Shows the fuel level in the fuel tank in %.
- 2 **Drive programme**  
Displays the current drive programme numerically (1-5). The drive programme can be changed; see the chapter entitled "Setting the drive programme".
- 3 **Operating hours**  
Displays the total operating hours completed by the truck. The hour meter operates as soon as the engine is started.
- 4 **Time**  
Displays the current time digitally in hours and minutes. The time can be adjusted; see the chapter entitled "Setting the time".

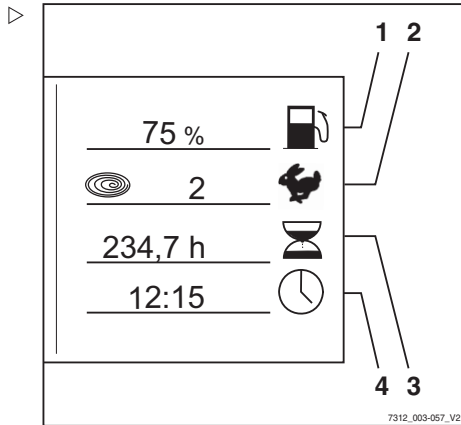

##### Additional indicators

- 5 **Menu change button**  
When the menu change button is pressed, the following additional indicators appear:
- 6 **"Service in" indicator**  
Displays the remaining time in hours until the next service work has to be carried out according to the maintenance schedule in the maintenance instructions. Contact the authorised service centre in good time.
- 7 **Total distance**  
Displays the total distance driven in kilometres.
- 8 **Daily kilometres**  
Displays the kilometres driven for the day.
- 9 **Daily driving time**  
Displays the hours driven for the day.

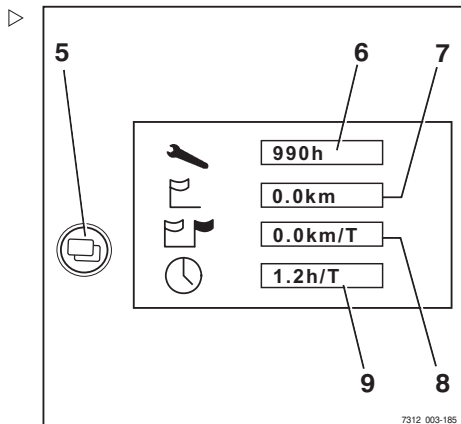

## Adjusting the displays

### **i** NOTE

The parking brake must always be engaged when you adjust the displays. The displays cannot be adjusted if the parking brake is not engaged.

### **i** NOTE

When adjusting the displays, do not actuate the hydraulic system operating devices. If you do, entry is interrupted and the display returns to the operating display.

The displays are adjusted in the CONFIGURATION menu.

- Turn the key switch to position "I".
- Press the drive program button (1) and the menu change button (2) at the same time.

The display changes to the PASSWORD menu.

- Press the return key (3).

The display changes to the CONFIGURATION menu.

The following settings are possible and can be found in the corresponding chapter:

- Setting the date and time
- Resetting the daily kilometres and daily operating hours
- Setting the language
- Configuring Blue Q

## Symbols in the display





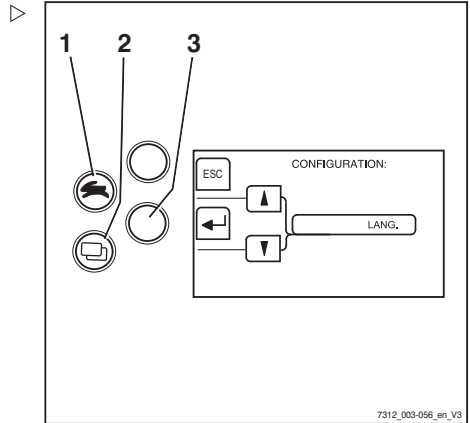















### Messages

To show operating messages, warning messages or error messages in the display, text messages and symbols are used.









## Operating the display and operating unit

### Symbols for operating messages





Description	Symbol
Empty field	No display
Please wait	
Service required	
Lift limitation	
Reference cycle	
Battery charging	
Drive program	
Hour meter	
Odometer	
Daily hour meter	
Daily odometer	
Speed	
Steering angle	
Load	
Time	
Hydraulic system	
Exh.gas purifier	
Coolant temperature	
Fuel level	
Blue-Q	
Power rating (average)	
Power rating (trend)	

### Symbols for warning messages

Description	Symbol
Parking brake	
Actuate seat switch	
Safety belt	
Battery acid level	
Neutral warning message	











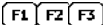



Description	Symbol
Are you sure?	?
Oil pressure	

### Symbols for error messages

Description	Symbol
Brake system malfunction	
Overheating of the engine	
Overheating	
Malfunction in the electrical system	
General malfunction	

### Symbols for auxiliary equipment soft key functions

For the auxiliary equipment, the following symbols for the soft key functions are used on the left in the display:

Description	Symbol
Empty field	No display
General function key OFF	
General function key ON	
Rear working spotlight OFF	
Rear working spotlight ON	
Front working spotlight OFF	
Front working spotlight ON	
Windscreen heating OFF	
Windscreen heating ON	
Rear window heating OFF	
Rear window heating ON	
Interior lighting OFF	
Interior lighting ON	
Roof wiper/washer OFF	
Roof wiper/washer ON	

## Operating the display and operating unit

Description	Symbol
Heater blower OFF	
Heater blower ON	
Rotating beacon OFF	
Rotating beacon ON	
Seat heater OFF	
Seat heater ON	
Signal horn OFF	
Signal horn ON	

### Symbols for the soft key functions for menu navigation and for acknowledging messages

For menu navigation and to acknowledge messages, the following symbols for the soft key functions are used on the left of the display:

Description	Symbol
Empty field	No display
button to return to the main menu	
button to confirm	
button to confirm	
button to reset	
Button to return to the main menu	
Button to return to the previous edit field	
button to scroll up	
button to scroll down	
button to count up	
button to count down	

### Status LEDs of the function keys for additional electrical installations

The current switch status of a button is indicated with LEDs next to the relevant function key for the additional electrical installation.



Description	LED
Function off	LED OFF
Function on	LED ON

### Symbols for numeric keypad

The available inputs and the positions of the keys are shown for inputting digits, **ESC** and **ENTER**.

Keys for the digits 1 to 7 and the **ESC** and **ENTER** keys for inputting the fleet manager password

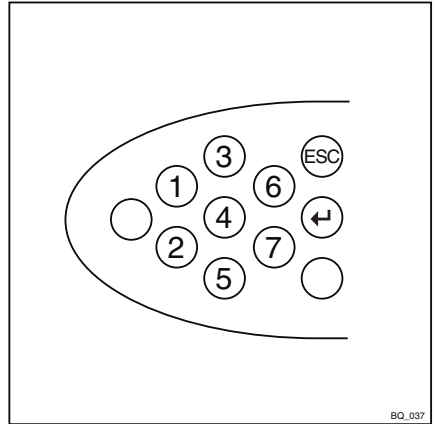

BQ\_037

Keys for digits 0 to 9 for inputting the driver PIN (access code)

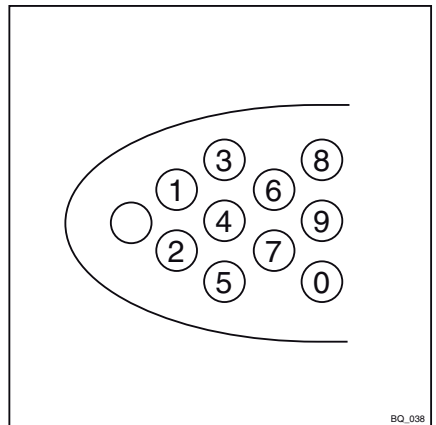

BQ\_038

## Operating the display and operating unit

### Setting the date or time

- Switch to the "CONFIGURATION" menu; see ⇒ Chapter "Adjusting the displays", P. 5-233.
- Press the drive program key (1) or menu selection key (2) until the option **TIME** appears. Confirm your selection by pressing the Return key (4).

The "TIME" menu appears.

- Press the drive program button (1) or the menu change button (2) until the desired time appears in the display.

As the buttons are held down for longer, the scrolling speed increases in three levels.

- Confirm the time set by pressing the Return key (4).
- Use the arrow key (3) to exit the menu and return to the next higher level.



#### NOTE

*The date is set in a similar manner.*

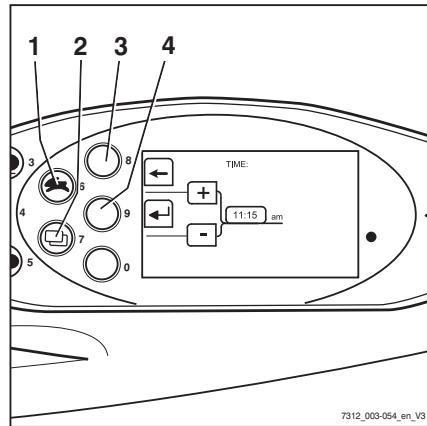

7312\_003-054\_en\_V3

### Resetting the daily kilometres and daily operating hours

The daily number of kilometres and daily operating hours displays can be reset to zero:

- Switch to the "CONFIGURATION" menu; see ⇒ Chapter "Adjusting the displays", P. 5-233.
- Press drive program button (1) or menu selection button (2) until the **DAY - KM** option appears. Confirm your selection by pressing the Return key.

The "DAY KM" menu appears.

- Reset the values by pressing the **[RES]** (4) button.
- Use the arrow key (3) to exit the menu and return to the next higher level.

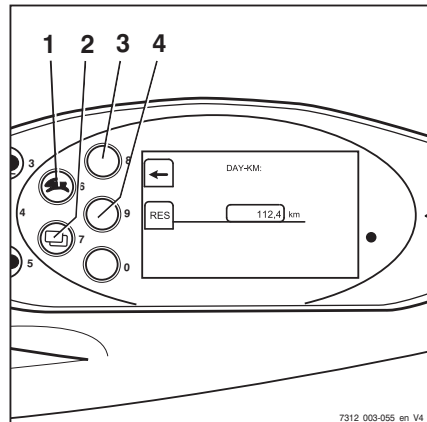

7312\_003-055\_en\_V4

**i NOTE**

*The daily operating hours are reset in the same manner.*

**Setting the language**

The displays can be shown in additional languages:

- Switch to the "CONFIGURATION" menu; see ⇒ Chapter "Adjusting the displays", P. 5-233.
- Press drive program button (1) or menu selection button (2) until the LANGUAGE option appears. Confirm your selection by pressing Return key (4).

The "LANGUAGE" menu appears.

- Press drive program button (1) or menu change button (2) until the desired language appears in the display.
- Confirm your selection by pressing the Return key (4).
- Use arrow key (3) to exit the menu and return to the next higher level.

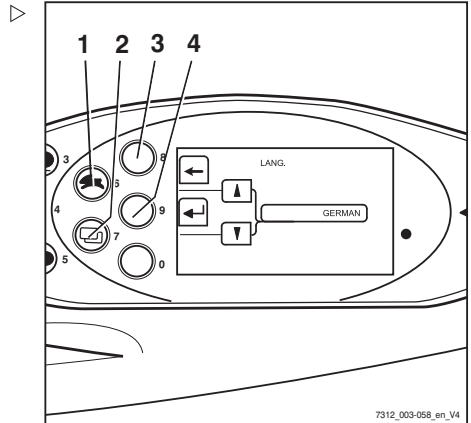
**Soft key button for operating various equipment variants**

There are two soft key columns available on the display operating unit. With these soft key columns, you can switch the additional functions on and off, e.g. a rotating beacon. The second soft key column is only available if the truck has more than three additional functions.

## Operating the display and operating unit

A grey bar (3) highlights the active soft key column, i.e. the soft keys in this column can be operated. To change the soft key column:

- Briefly press the "Menu change button" (1). The grey bar jumps to the other soft key column. The required soft keys are now active and the functions assigned to them can be switched on and off using the corresponding soft key buttons (2).

### NOTE

*In order to shift between the individual menus of the display operating unit, press the "Menu change button" (1) for approx. 1 second.*

### NOTE

*The functions of the two soft key columns depend on the individual equipment of the truck. Therefore, the soft keys on your display operating unit may vary to those shown here.*

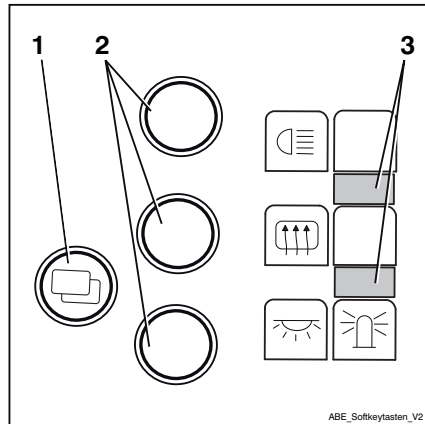

## Configuring Blue-Q efficiency mode

The following operating modes can be selected to activate the Blue-Q efficiency mode:

### STANDARD

- Blue-Q is turned off whenever the truck is commissioned. The driver can use the Blue-Q button to switch efficiency mode on and off at any time while the truck is being operated

### FIXED

- Blue-Q is switched on permanently whenever the truck is commissioned and during truck operation. The driver cannot turn efficiency mode off

### FIXED-FLEX

- Blue-Q is turned on whenever the truck is commissioned. The driver can use the Blue-Q button to switch efficiency mode on and off at any time while the truck is being operated

Operating the display and operating unit

- Switch to the CONFIGURATION menu; see ⇒ Chapter "Adjusting the displays", P. 5-233
- Keep pressing the drive programme button (1) or the menu change button (2) until option BLUE Q CONFIGURATION appears.
- Confirm your selection by pressing the Return key (4).

The BLUE-Q CONFIGURATION menu appears.

- Press drive program button (1) or menu change button (2) until the desired efficiency mode appears in the display.
- Confirm the set efficiency mode with Return button (4).
- Use arrow key (3) to exit the menu and return to the next higher level.

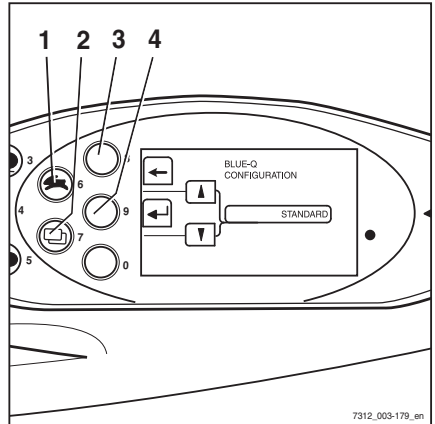

## Blue-Q efficiency mode

### Blue-Q efficiency mode

#### Functional description

The Blue-Q efficiency mode affects both the drive unit and the activation of the additional consumers, and reduces the truck's energy consumption.

If the efficiency mode has been activated, the acceleration behaviour of the truck changes to make acceleration more moderate.

When travelling at low speeds—normally when manoeuvring—no reduction is noticeable despite the activated efficiency mode. For moderate speeds of at least approx. 7 km/h, acceleration is gentler. Therefore, on distances of up to approx. 40 m, lower speeds are reached than would be the case if the efficiency mode was not activated.

Blue-Q has no influence on:

- Maximum speed
- Climbing capability
- Traction
- Braking characteristics

#### NOTE

*The Blue-Q efficiency mode can be switched on and off in the STANDARD and FIXED-FLEX operating modes. If the FIXED operating mode is configured in the display operating unit, the Blue-Q button has no function and the Blue-Q efficiency mode is switched on permanently; see also chapter "Configuring Blue-Q efficiency mode".*

#### Effects on additional consumers

The following table shows the specific conditions that cause certain auxiliary devices to shutdown when Blue Q is activated. The auxiliary devices available depend on the truck equipment.

Shut-off	Seat switch	Truck stopped	Drive direction
Front working spotlight*	X	X	Backwards > 3 km/h
Rear working spotlight*	X	X	Forwards
Top double working spotlight*	X	X	> 3 km/h
Headlight*	X	X	-
Side light	-	-	-
Front wiper	X	X	Backwards > 3 km/h
Rear wiper	X	X	Forwards
Seat heater	X	-	-
Cab heating	X	-	-

\*No shutdown for StVZO (Road Traffic Licensing Regulations) equipment.

## Switching efficiency mode Blue-Q on and off

### NOTE

*The Blue-Q efficiency mode can be switched on and off in the STANDARD and FIXED-FLEX operating modes. If the FIXED operating mode is configured in the display operating unit, the Blue-Q button has no function and the Blue-Q efficiency mode is switched on permanently. For information on configuring the Blue-Q operating modes, see chapter "Configuring Blue Q efficiency mode".*

## Blue-Q efficiency mode

- Press the Blue-Q button (1).

The Blue-Q symbol (2) appears next to the drive programme symbol in the display and operating unit, which means that the Blue-Q efficiency mode is activated.

Pressing the Blue-Q button once again turns the Blue-Q efficiency mode off again.

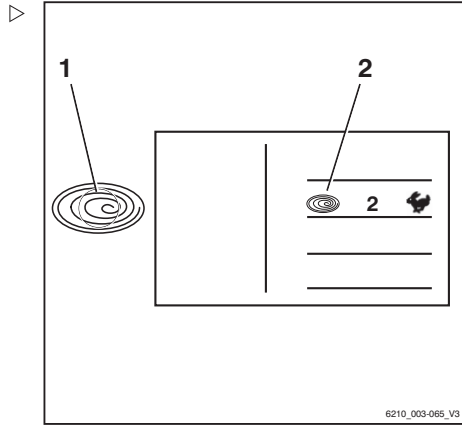



## Display messages

### Display content

On the display of the display-operating unit, event-related messages may appear due to certain truck conditions.

The following types of message may appear individually or in combination:

- A graphic symbol (2)
- The message (3)
- An error code (4) consisting of a letter and a four-digit number



#### NOTE

*Each time a message appears, the "Malfunction" display (1) also lights up.*

Messages are always shown repeatedly and for a certain period of time, according to the event.

In the case of successive events, the respective messages are displayed one after another on the display.

After a few seconds, the display will alternate between the last shown operating display and the message.

The frequency of alternation depends on the type of event.

- If a message appears, follow these operating instructions.

Once the event is remedied, the message will disappear.

If a malfunction continues to occur, the message will continue to appear.

- Park the truck safely.
- Inform the authorised service centre.

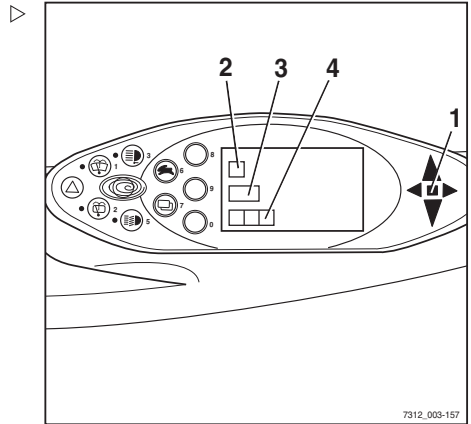

7312\_003-157

## Display messages

### Error code table

The table gives an overview of possible displays. In the "Comment" column, you will find information on how to proceed should any of these messages be displayed.

Message text/ Error code	Comment
Control unit A1401	
Control unit A1431	
A2551	
Oil pressure A3040	No brake oil pressure or sensor fault, truck only moves at emergency mode speed. Notify your authorised service centre.
Oil pressure A3043	Brake oil pressure too high or sensor fault, truck only moves at emergency mode speed. Notify your authorised service centre.
OVERHEATING A5022	Traction motor(s) is/are too hot. 1st phase: regulation of acceleration and speed. 2nd phase: limitation of phase current in converter (emergency driving function is retained). The error automatically disappears as soon as the temperature is below the limit. If the error occurs frequently, notify your authorised service centre.
ACCEL. SENSOR A3002 A3003 A3004 A3005 A3006 A3007 A3505	Sensor fault, truck cannot be driven. Contact your service centre.
ACCEL. SENSOR A3008	Accelerator voltages (for dual pedal) do not match; truck cannot be driven. Contact your service centre.
ACCEL. SENSOR A3811	Accelerator configuration is invalid; truck cannot be driven. Notify your authorised service centre.
BRAKE SENSOR A3016 A3017	Sensor fault; truck can only be driven at emergency mode speed. Notify your authorised service centre.
BRAKE SENSOR A3035	Switch defective, truck only moves at emergency mode speed. Notify your authorised service centre.

Message text/ Error code	Comment
CONFIGURATION A2111	Parameterisation error or defective printed circuit board; drive unit and hydraulic drive not functioning. Notify your authorised service centre.
CONFIGURATION A3801	Parameterisation error; drive unit and hydraulic drive not functioning. Notify your authorised service centre.
CONFIGURATION A3812	Drive programme parameters are outside the permitted range. The drive programme parameters are limited internally. Notify your authorised service centre.
SEAT SWITCH A3027	Seat switch has not been operated for approx. 8 hours. Truck can possibly still be driven at a reduced speed and with reduced lifting capacity. Stand up briefly and then sit down again. If this does not resolve the problem, contact your authorised service centre.
STEERING A3215	Sensor fault; truck moves at emergency mode speed. Notify your authorised service centre.
DIRECTION SWITCH A3020	Switch error; no or limited drive unit function. Notify your authorised service centre.
LIFTING A3102 A3103	Sensor fault; no or limited hydraulic drive function. Notify your authorised service centre.
TILTING A3107 A3108	Sensor fault; no or limited hydraulic drive function. Notify your authorised service centre.
EXT1 A3112 A3113	Sensor fault; no or limited hydraulic drive function. Notify your authorised service centre.
EXT2 A3117 A3118	Sensor fault; no or limited hydraulic drive function. Notify your authorised service centre.
VERTICAL MAST A3130 A3131 A3132	No hydraulic function. Turn off "vertical lift mast position". Notify your authorised service centre.
VERTICAL MAST ERROR A3135	No hydraulic function. Turn off "vertical lift mast position". Notify your authorised service centre.
POWER SUPPLY A2242 A2257	Transmitter power supply short circuit. Truck cannot be driven. Notify your authorised service centre.

## Display messages

Message text/ Error code	Comment
SURVEILLANCE A2801 A2802 A2808 A2809 A2810 A2815	Drive unit not functioning. Release accelerator pedal. If this error occurs sporadically, it can be tolerated. If the operational capacity is impaired, notify your authorised service centre.
SURVEILLANCE A2803 A2806	Drive direction is set to neutral. Reselect the drive direction. If this error occurs sporadically, it can be tolerated. If the operational capacity is impaired, notify your authorised service centre.
SURVEILLANCE A2817	Truck is not ready for operation. Turn the key switch to the zero position and restart. If this error occurs sporadically, it can be tolerated. If the operational capacity is impaired, notify your authorised service centre.
DRIVE A5041	Temperature sensor fault Notify your authorised service centre.
OIL PRESSURE A5631	Engine faulty (no oil pressure) or sensor faulty. Engine is switched off for protection. Notify your authorised service centre.
COOLANT LEVEL A5611	Fan is not running. Cooling fluid level too low, check the cooling fluid level and top up the cooling fluid if necessary. If this does not resolve the problem, contact your authorised service centre.
AIR FILTER A5651	Replace the filter cartridges. If this does not resolve the problem, contact your authorised service centre.
CONTROL UNIT A3305	CI0 not functioning. Notify your authorised service centre.
EXH. GAS PURIFIER A5791	No regeneration and no intermediate glow. Notify your authorised service centre.
EXH. GAS PURIFIER A5792 A5793 A5794 A5796	Regeneration cannot be started. Notify your authorised service centre.
EXH. GAS PURIFIER A5795 A5797 A5798	Regeneration has been interrupted. Notify your authorised service centre.
ALTERNATOR A5811	Starter battery is not charged. Notify your authorised service centre.

Message text/ Error code	Comment
V-engine malfunction A5821	Engine control unit (ECU) reports engine error. Truck can still be operated. Notify your authorised service centre.
Switch off immediately! V-engine A5822	Engine control unit (ECU) reports serious engine error, switch engine off immediately. Truck only moves at emergency mode speed. The lifting speed is severely reduced. Notify your authorised service centre.

## General messages

### NOTE

*Some of the following messages are equipment-specific and may not appear on the display and operating unit of every truck. The following messages are therefore intended only as a reference.*

### SERVICE BRAKE message

If the message SERVICE BRAKE appears on the display, notify the authorised service centre.

- Park the truck securely for checking by the authorised service centre.
- If multi-disc brakes in the drive wheel units are blocked, tow the truck.

### APPLY HANDBRAKE message

#### DANGER

**Risk of fatal injury from being run over if the truck rolls away!**

Parking the truck without the parking brake applied is dangerous and is not permitted.

- The truck must not be parked on a slope.
- Only leave the truck when the parking brake has been applied.
- In emergencies, secure the truck using wedges on the side facing downhill.

## Display messages

### NOTE

*The truck is equipped with a negative spring-operated brake. Switching off the truck will block the multi-disc brakes in the drive wheel units after a few minutes. However, the truck can still roll until the drive wheel units are blocked. For this reason, the parking brake must always be applied before you leave the truck!*

If you park the truck without applying the parking brake and then vacate the driver's seat, the APPLY HANDBRAKE message will appear in the display (variant). An optional signal tone sounds.

- Apply the parking brake.

The APPLY HANDBRAKE message disappears.

If the truck moves even though the parking brake is applied:

- Drive the truck onto level ground and park it safely. Secure it with wedges if necessary.
- Notify the authorised service centre.

### **BRAKE SENSOR message**

If the BRAKE SENSOR message appears in the display, the maximum driving speed will be reduced. The brake sensor in the brake pedal must be checked.

- Notify the authorised service centre.

### **CODE DENIED message**

If the message CODE DENIED appears on the display, the driver PIN has been entered incorrectly three times. The input is then locked for five minutes before another attempt can be made.

- Enter the driver PIN again after five minutes.

### **ACCELERATOR message**

If the ACCELERATOR message appears on the display, the truck will remain stationary. The accelerator must be checked.

- Notify the authorised service centre.

### **SWITCH OFF TRUCK? message**

If the message SWITCH OFF THE TRUCK? appears on the display, the switching-off of the truck is verified.

- Press the corresponding softkey on the display and operating unit to switch off the truck or cancel the operation.

### **PARKING BRAKE ACTIVE message**

If the electric parking brake is applied, the PARKING BRAKE ACTIVE message appears on the display for 5 seconds.

- Release the parking brake to enable driving mode.

### **RELEASE PARKING BRAKE message**

If the message RELEASE PARKING BRAKE appears on the display, driving mode cannot be enabled until the parking brake has been released by pressing the button.

- Release the parking brake by pressing the button.

### **PARKING BRAKE: APPLY HANDBRAKE! message**

If the message PARKING BRAKE : APPLY HANDBRAKE ! appears on the display, the electric parking brake is faulty.

- Release the parking brake by pressing the button.

### **LOWER FORKS message**

#### **⚠ DANGER**

**There is a risk of fatal injury from a falling load or parts of the truck being lowered!**

Parking the truck with the load lifted is dangerous and is not permitted under any circumstances! The increased safety provided by this function must not be misused in order to take safety risks.

- Lower the load fully before leaving the truck.

## Display messages

### The fork is not lowered.

If the fork is above the height sensor, the key switch is turned off and the seat vacated, the **LOWER FORKS** message appears in the display (variant). An optional signal tone sounds.

- Lower the fork to the ground.

The message **LOWER FORKS** disappears.

### STEERING message

If the **STEERING** message appears in the display, the truck will only move at emergency mode speed. The steering angle sensor must be checked.

- Notify the authorised service centre.

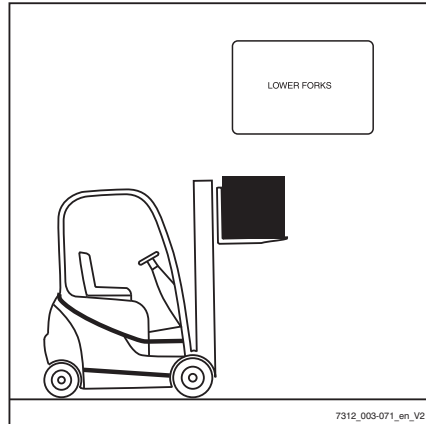

### TILTING SPEED message

If the message **TILTING SPEED** appears on the display after the welcome screen, the tilting speed of the lift mast on this truck is significantly higher than on previous trucks in this family.

### EMERGENCY SWITCH message

#### **WARNING**

No electric braking assistance is available when the emergency off switch is actuated!

Actuating the emergency off switch will disconnect the drives from the power supply.

- To brake, actuate the service brake.

The truck is equipped with an emergency off switch. When this switch is actuated, the driving functions and the functions of the working hydraulics are blocked.

The **EMERGENCY SWITCH** message appears periodically when the following criteria are met:

- The key switch is set to stage "I"
- The emergency off switch is actuated
- An operating device is actuated



## ? VERTICAL POSITION

If the message ? VERTICAL POSITION appears on the display, calibration of the "vertical lift mast position" has been activated.

- Save the mast position or cancel the calibration.

## REFERENCE CYCLE message

If the fork was lowered after the truck was switched off, the control electronics do not know the position of the fork when the truck is restarted. The truck will only travel at a reduced driving speed. Depending on the position of the fork, the message REFERENCE CYCLE (variant) may appear in the display. To align the position with the control electronics, the fork must be raised.

- Switch on the key switch.

The truck will only travel at a reduced driving speed. The message REFERENCE CYCLE may appear in the display.

- Raise the fork.

The message REFERENCE CYCLE goes out, or now appears in the display for the first time and then goes out.

- To drive again, lower the fork to a maximum of 300 mm above the ground.

The truck can now be driven again with no speed limitation.

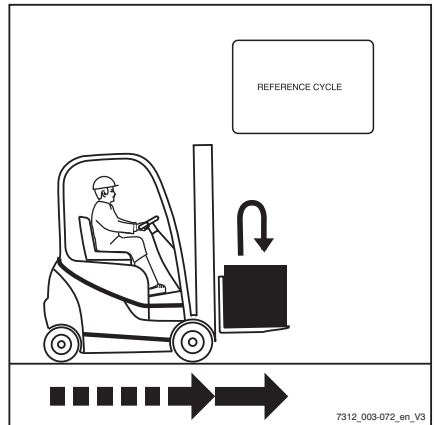

## Display messages

## SAFETY BELT message

**⚠ DANGER****Risk of fatal injury in the event of falling from the truck if it tips over!**

If the truck tips over, the driver is at risk of injury even if a restraint system is used. The risk of injury can be reduced by using a combination of a restraint system and a seat belt. In addition, the seat belt protects against the consequences of rear-end collisions and falling off ramps.

- We recommend that you always use the seat belt.

This device (variant) ensures that if the seat belt is not being used or is being used incorrectly, the truck will only drive slowly or (optionally) will not drive at all.

Depending on the configuration selected, the working hydraulics functions (lifting/tilting) are either available as normal, slowed down or not available at all.

The SAFETY BELT message with the restricted driving and lifting functions is triggered by the following circumstances:

- Seat belt not worn and driver's seat occupied
- The seat belt is constantly fastened but the driver's seat is only occupied afterwards
- The seat belt is not fastened until after the key switch has been switched on
- The seat belt is unfastened while driving
- If the SAFETY BELT message appears, fasten the seat belt in accordance with the regulations.

The truck can again be operated without restrictions.

If the seat belt is released while driving, the truck will be limited to low driving speeds or will be braked to a halt.

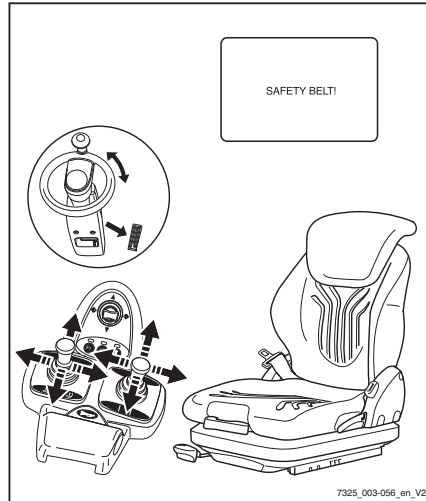

**⚠ DANGER****Risk of accident!**

- The speed must be adjusted to suit the driving situation!

The increased safety provided by this function must not be misused in order to take safety risks.

---

**ARE YOU SURE ? message**

If the message ARE YOU SURE ? appears on the display, a prior prompt is verified.

- Press the corresponding softkey on the display and operating unit to continue or to cancel the operation.

**SEAT SWITCH message**

The truck is equipped with a seat switch.

If the SEAT SWITCH message appears, the driving functions and the working hydraulics are blocked.

The SEAT SWITCH message is triggered by the following situations:

- The seat switch is not actuated while the accelerator pedal or steering wheel is actuated
- The seat switch is not actuated while the operating device for the working hydraulics is actuated
- The shift time has been exceeded
- The operating time has been exceeded

** NOTE**

*The operating devices shown in the following illustrations are only examples and may differ from the equipment in your truck.*

## Display messages

### ▷ The seat switch is not actuated while the accelerator pedal or steering wheel is actuated

The accelerator pedal or the steering wheel is actuated, even though no one is sitting in the driver's seat. The message **SEAT SWITCH** appears on the display. The truck will not move.

- Sit in the driver's seat and fasten the seat belt.

The truck can be driven again without restrictions.



### ▷ The seat switch is not actuated while the operating device for the working hydraulics is actuated

An operating device for the working hydraulics is actuated, even though no one is sitting in the driver's seat. The message **SEAT SWITCH** appears on the display. The working hydraulics functions cannot be executed.

- Sit in the driver's seat and fasten the seat belt.

The working hydraulics can be operated again.

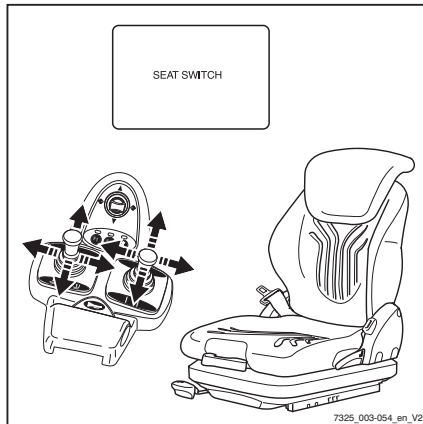

**The shift time has been exceeded****i NOTE**

*The shift time is adjustable.*

If the key switch is switched on and the driver does not leave the seat before the set shift time is exceeded, SEAT SWITCH appears on the display. This is also the case if an operating device for the working hydraulics or the accelerator pedal is actuated. Depending on the configuration, the working hydraulic functions can be executed normally, only slowly or not at all.

- Stand up briefly from the seat, sit back down again and fasten the seat belt.

The truck can again be operated without restrictions.

**The operating time has been exceeded****i NOTE**

*The operating time is adjustable.*

If the key switch is switched on, the parking brake is released and the driver does not leave the seat before the set operating time is exceeded, and if neither the operating devices for the working hydraulics nor the accelerator pedal are actuated during this time, SEAT SWITCH appears on the display. The truck will not move. Depending on the configuration, the working hydraulic functions can be executed normally, only slowly or not at all.

- Stand up briefly from the seat, sit back down again and fasten the seat belt.

The truck can again be operated without restrictions.

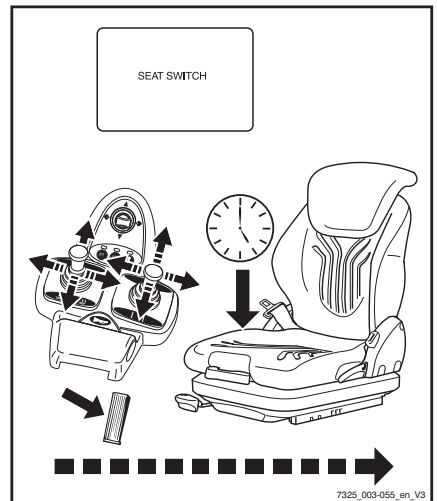
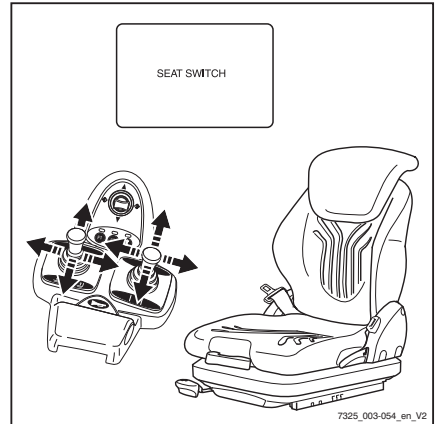
**OVERHEATING message**

If the message OVERHEATING appears on the display, the traction motors have overheated. The acceleration and the speed of the truck are reduced.

- Allow the truck to cool down.
- If the error persists, contact your authorised service centre.

## Display messages

### **SURVEILLANCE message**

If the SURVEILLANCE message appears in the display, there is a fault in the process monitoring.

This shuts off the drive unit.

- Switch the key switch to the "0" position and then back to the "I" position.
- Start the engine.
- Release accelerator pedal.
- Select the drive direction again.



#### **NOTE**

*If this error occurs sporadically, it can be tolerated. If the operational capacity is impaired, notify your authorised service centre.*

### **NOT VALID message**

If the message NOT VALID appears on the display, an incorrect driver PIN has been entered when entering the access code.

- Once the message goes out, enter the driver PIN again.

## Drive-specific messages



#### **NOTE**

*Some of the following messages are equipment-specific and may not appear on the display and operating unit of every truck. The following messages are therefore intended only as a reference.*

### **EXH.GAS PURIFIER message**

If the EXH.GAS PURIFIER message appears on the display, the particle filter is full.

- Regenerate the particle filter.

 **NOTE**

*If the EXH . GAS PURIFIER message appears during regeneration, a fault has occurred.*

- *Notify the authorised service centre*

**EXH.GAS PURIFIER PLEASE WAIT message**

If the EXH . GAS PURIFIER PLEASE WAIT message appears on the display, the particle filter is being regenerated.

- Wait for particle filter regeneration.

**EXH.GAS PURIFIER SERVICE! message !!**

If the message EXH . GAS PURIFIER SERVICE! !! appears on the display, the particle filter was not regenerated on time. The particle filter system must be repaired by the authorised service centre.

- To avoid damage, take the truck out of operation until it is repaired.
- Notify the authorised service centre.

**CUTOUT MODE message**

When automatic shut-off is activated, the message CUTOUT MODE appears on the display; see the section entitled "Automatic shut-off of the internal combustion engine (variant)".

- Sit on the driver's seat.

The message goes out and the truck is ready for operation again.

**ADBLUE URGENT! message**

If the AdBlue filling level drops below 2 litres, the driving speed is limited to 2 km/h.

- Maintain the quality of the AdBlue; see the section entitled "Maintenance data table".
- Top up the AdBlue.

## Display messages

### **ADBLUE FILLING LEVEL message**

If the filling level of the AdBlue tank falls sharply, the **ADBLUE FILLING LEVEL** message appears on the display and operating unit.

If an AdBlue filling level of 2 litres is reached, the driving speed is limited to 5 km/h.

- Maintain the quality of the AdBlue; see the section entitled "Maintenance data table".
- Top up the AdBlue.

### **ADBLUE REFILL 5l message**

If the message **ADBLUE REFILL 5l** appears, max. 5 litres of AdBlue must be added.

- Maintain the quality of the AdBlue; see the section entitled "Maintenance data table".
- Top up the AdBlue.

### **ADBLUE QUALITY message**

This truck is equipped with a sensor that measures the quality of the exhaust gas cleaned using AdBlue.

If the quality of the exhaust gas deteriorates, the **ADBLUE QUALITY** message appears on the display and operating unit.

If the exhaust gas quality deteriorates further, the driving speed is limited to 5 km/h.

- Maintain the quality of the AdBlue; see the section entitled "Maintenance data table".
- Top up the AdBlue.

### **ADBLUE QUALITY URGENT! message**

If the quality sensor detects a deterioration in the quality of the exhaust gas cleaned with AdBlue, the message **ADBLUE QUALITY URGENT!** appears on the display and operating unit.

The driving speed is limited to 2 km/h.

- Maintain the quality of the AdBlue; see the section entitled "Maintenance data table".
- Top up the AdBlue.



### ASH LOAD message

If the message ASH LOAD appears on the display, the particle filter has become clogged with ash. Repair must be performed by the authorised service centre.

- Notify the authorised service centre.

### GLOW message

If the GLOW message appears in the display, the engine is being preheated.

Preheating can take up to 22 seconds. If the engine is already at operating temperature, preheating is not performed.

- Once the message goes out, start the engine.

### HYBRID SYSTEM message

If the message HYBRID SYSTEM is shown on the display, the energy storage system has been deactivated because of an error.

The truck remains operational. However, the fuel consumption increases marginally.

- Contact the authorised service centre in order to rectify the error.

### HYDRAULIC PUMP message

If the HYDRAULIC PUMP message appears on the display, there was an error in the hydraulic-pump volume control.

The engine can be overloaded and stall as a result of the overload. This causes the assisted steering and regenerative braking to malfunction. Further operation of the truck is therefore not permissible. The driving speed is limited to 5 km/h.

- Contact the authorised service centre in order to rectify the error.

### Message: FUEL FILTER

The fuel filter is equipped with a level indicator that reports water aggregation in the fuel filter on the display and operating unit. If the message FUEL FILTER appears in the

## Display messages

display, the fuel filter is saturated with water.  
This water must be drained.

- Drain water from the fuel filter.

### COOLANT LEVEL message

If the message **COOLANT LEVEL** appears on the display, the cooling fluid level is too low.

- Check the cooling fluid level and add cooling fluid if necessary.

### CAUTION

Risk of engine damage!

If the cooling fluid level is low, this indicates a leak in the cooling system.

- Check the cooling system for leaks; see the chapter entitled "Cleaning the radiator, checking for leaks".

### EMPTY message

If the message **EMPTY** flashes on the display, the gas supply is almost exhausted.

- Change the LPG cylinder or fill the LPG tank.

### ALTERNATOR message

If the **ALTERNATOR** message appears in the display, this means that the alternator is no longer charging the starter battery.

This may have the following causes:

- Drive belt loose or damaged
- The electrics to or from the alternator are faulty
- The alternator is faulty

### NOTE

*If the fault is not rectified within a short time, the starter battery will soon run out of charge and it will no longer be possible to operate the truck.*

- Notify the authorised service centre.

### LPG AUTO. VALVE message

If the message **LPG AUTO. VALVE** appears on the display when the LPG engine is switched off, and the engine does not switch off until after approximately 60 seconds, there is an error.

The truck can still be operated but your authorised service centre must be notified of the error immediately. The error message is shown on the display and operating unit until the error has been rectified by the authorised service centre.

### AIR FILTER message

If the **AIR FILTER** message appears on the display, the air filter cartridges must be changed; see the chapter entitled "Replacing the air filter cartridges".

### OIL PRESSURE message

#### CAUTION

Risk of engine damage!

If the **OIL PRESSURE** message appears in the display, the engine's oil pressure is too low.

- Stop the engine immediately.

The message can have different causes:

- The engine has overheated
  - Insufficient oil
  - The oil is insufficiently viscous
  - Engine damage
- Check engine oil level.
  - Change the engine oil if necessary.
  - Notify the authorised service centre.

### REGENERATION COMPLETED message

If the message **REGENERATION COMPLETED** appears on the display, parked regeneration is complete. The truck is ready for operation again.

## Display messages

### SCR-SYSTEM SERVICE message

If the message SCR - SYSTEM SERVICE appears on the display, there is a fault in the SCR exhaust gas treatment system.

- Notify the authorised service centre.

### SCR-SYSTEM MALFUNCTION message

If the message SCR - SYSTEM MALFUNCTION appears on the display, there is a fault in the SCR exhaust gas treatment system.

- Notify the authorised service centre.

### Message PARK. REG. URGENT!!!

If the message PARK. REG. URGENT!!! appears on the display, parked regeneration of the particle filter is required urgently.

- Perform parked regeneration.

Until parked regeneration has been carried out, the maximum speed of the truck is reduced to 2 km/h. The lifting speed is restricted.

### Message PARK. REG. ERROR

If the message PARK. REG. ERROR appears on the display, parked regeneration was interrupted by applying the parking brake or by a malfunction in the internal combustion engine.

- Apply the parking brake.
- Restart parked regeneration.
- If the parking brake was not actuated and the message PARK. REG. ERROR appears anyway, notify the authorised service centre.

### Message START PARK. REG. ?

If the message START PARK. REG. ? appears on the display, the truck is ready for parked regeneration.

- Perform parked regeneration.

**START IC ENGINE message**

If the message **START IC ENGINE** appears on the display, the internal combustion engine of the truck can be started.

- Start the engine.

## Operating in special operating situations

# Operating in special operating situations

## Transport

### ⚠ CAUTION

Risk of material damage from overloading!

If the truck is driven onto a means of transport, the load capacity of the means of transport, the ramps and loading bridges must be greater than the total actual weight of the truck. Components may become permanently deformed or damaged due to overloading.

- Determine the total actual weight of the truck.
- Only load the truck if the load capacity of the means of transport, the ramps and loading bridges is greater than the total actual weight of the truck.

### Determining the total actual weight

- Park the truck securely; see ⇒ Chapter "Parking the truck securely and switching it off", P. 5-291.
- Determine the unit weights by reading the truck nameplate and, if necessary, the attachment (variant) nameplate.
- Add the determined unit weights to obtain the total actual weight of the truck:

Tare weight (1)

- + Ballast weight (variant) (2)
- + Attachment net weight (variant)
- + 100 kg allowance for driver
- = Total actual weight



<b>STILL</b>			
Type-Modèle-Typ / Serial no.-No. de série-Serien-Nr. / year-année-Baujahr			
Rated capacity Capacité normale Nenn-Tragfähigkeit	kg	Unladen mass Masse à vide Leergewicht	kg
Battery voltage Tension batterie Batteriespannung	V	max. min.*	kg kg
Rated drive power Puissance mot.nom. Nenn-Antriebsleist.	kW		kg

CE \* see Operating instructions  
voir Mode d'emploi  
siehe Betriebsanleitung

7321\_003-011\_V2

**⚠ DANGER****Risk of accident from the truck crashing!**

Steering movements can cause the tail end to veer off the loading bridge towards the edge. This may cause the truck to crash

- Before driving over a loading bridge, ensure that it is installed and secured properly.
- Ensure that the transport vehicle onto which the truck is to be driven has been sufficiently secured against moving.
- Maintain a safety distance from the edges, loading bridges, ramps, working platforms etc.
- Drive slowly and carefully onto the transport vehicle.

**Inserting wedges**

- Use two wedges to secure each of the front and rear wheels against rolling away.

**Lashing down****⚠ CAUTION**

Abrasive lashing straps can rub against the surface of the truck and cause damage.

- Position slip-resistant pads beneath the lifting points (e.g. rubber mats or foam).

- Attach lashing straps (1) to both sides of the truck and lash the forklift to the rear.

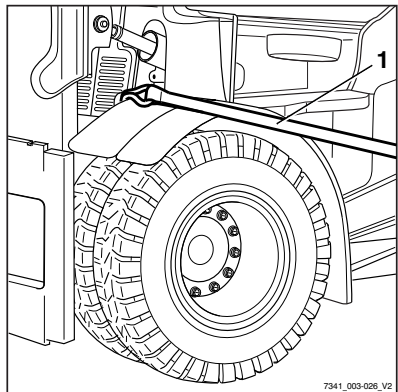
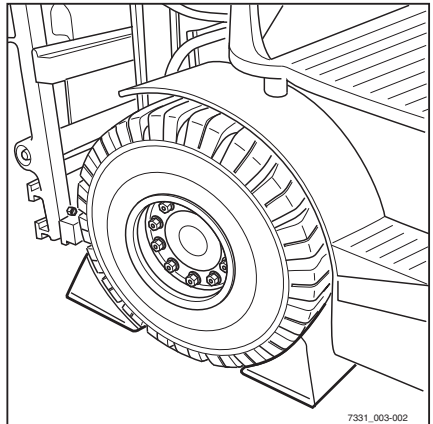

## Operating in special operating situations

- Attach lashing straps (1) to the coupling pin (2) or loop around the coupling pin and lash the truck to the side. ▷

### **⚠ DANGER**

#### **The truck can slip if the lashing straps slip!**

The truck must be lashed securely so that it cannot move during transportation.

- Make sure that the lashing straps are tightened securely and that the pads cannot slip off.

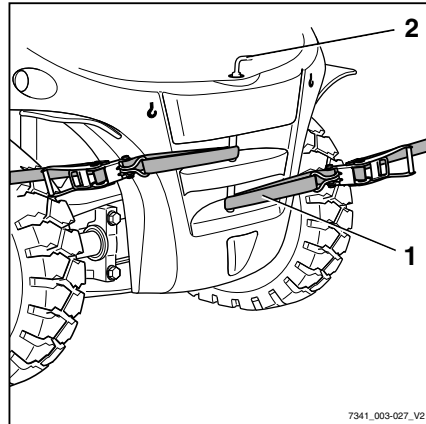

## Towing

### **⚠ DANGER**

#### **The brake system on the towing vehicle may fail. Risk of accident!**

If the brake system of the towing vehicle is not adequately sized, the vehicle may not brake safely or the brakes may fail. The towing vehicle must be able to absorb the tractive and braking forces from the unbraked towed load (total actual weight of the truck).

- Check the tractive and braking forces of the towing vehicle.

### **⚠ DANGER**

#### **The truck could drive into the towing vehicle when the towing vehicle brakes. Risk of accident!**

If a rigid connection has not been used for power transmission in two directions during towing, the truck may drive into the towing vehicle when the towing vehicle brakes. For safety reasons, only a tested tow bar may be used.

- Use a tested tow bar.

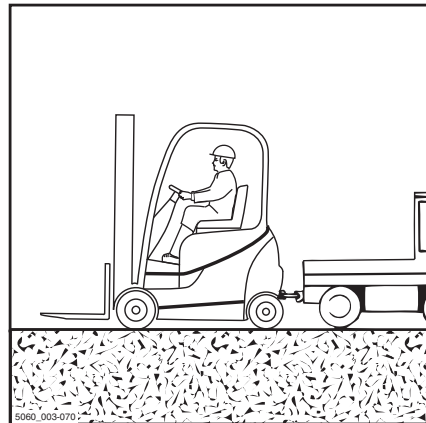



**⚠ CAUTION**

If the truck drive between the drive motor and the drive axle is not interrupted, the drive may be damaged.

- Place the drive direction switch in the neutral position.

**⚠ DANGER**

**People can be crushed between the truck and towing vehicle during manoeuvring. There is a risk of fatal injury!**

The towing vehicle may only be manoeuvred and the tow bar may only be attached using a second person as a guide. This ensures that the driver of the towing vehicle and the mechanic attaching the tow bar are aware of possible risks.

- Only manoeuvre with a guide.

**⚠ CAUTION**

Steering is stiff! There is no power steering if the hydraulics fail!

- The selected towing speed must allow the truck and towing vehicle to be effectively braked and controlled at all times.

**⚠ CAUTION**

If the truck is not steered while it is being towed, it may veer out in an uncontrolled manner!

- The truck being towed must also be steered by a driver.
- The driver of the truck being towed must sit in the driver's seat and fasten the seat belt before towing.
- Where possible, activate the restraint systems provided.

## Operating in special operating situations

### **⚠ CAUTION**

Component damage as a result of blocked brakes!

The truck is equipped with a negative spring-operated brake. As a result, when you switch the engine off, the multi-disc brakes in the drive wheel units block. For towing, the brake must be released at the brake valve. Otherwise, the truck is towed with the wheels blocked.

Once the spring-operated brake is released, pressure builds up gradually again in the brake hydraulics and the brakes can block again. Note the towing time when the key switch is switched off. The towing process must be interrupted in each case and the brake released again.

- Releasing the spring-operated brake
  - Note the towing time and release the spring-operated brake again as necessary.
- 
- Set down load and lower fork arms close to the ground.
  - Place the drive direction switch in the neutral position.
  - Apply the parking brake.
  - Switch off the key switch.
  - Check the tractive and braking forces of the towing vehicle.
  - With the help of a guide, move the towing vehicle to the truck.
  - Secure the tow bar to the tow coupling of the towing vehicle and the truck.
  - Release the spring-operated brake
  - Sit in the driver's seat in the truck to be towed and fasten the seat belt.
  - Where possible, activate the restraint systems provided.
  - Release the parking brake.
  - Select a towing speed that allows the truck and towing vehicle to be effectively braked and controlled at all times.
  - Tow the truck.
  - Note the towing time (refer to the table in the section entitled "Releasing the spring-operated brake") and release the spring-operated brake again as necessary.

- After towing, secure the truck against rolling away (e.g. by applying the parking brake or using wedges).
- Remove the tow bar.

### Crane loading

Crane loading is only intended for transporting the complete truck, including the lift mast, for its initial commissioning. For application conditions that require frequent loading or that are not dealt with here, please contact the manufacturer with regard to special equipment variants.

Trucks may only be laden by persons with sufficient experience with the suitable harnesses and hoists.

### Determining the loading weight

- Park the truck securely; see chapter "Parking the truck securely".
- Determine the unit weights by reading them off the truck nameplate and, if necessary, the attachment (variant) nameplate.
- Add the determined unit weights to obtain the loading weight of the truck:
  - Tare weight (1)
  - + Ballast weight (variant) (2)
  - + Attachment net weight (variant)
  - = Loading weight

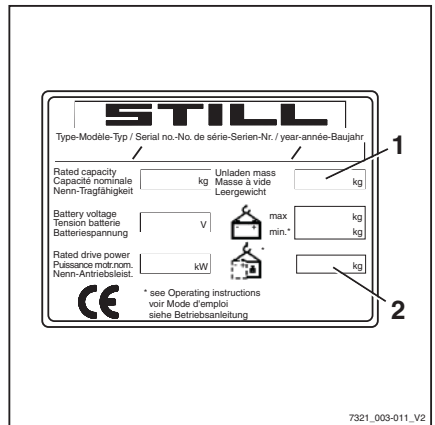

## Operating in special operating situations

### Hooking on the lifting straps

#### ⚠ CAUTION

Harnesses may damage the truck's paintwork!

Harnesses may damage paintwork by rubbing and pressing on the surface of the truck. Particularly hard or sharp-edged harnesses, such as wires or chains, can quickly damage the surface.

- Use textile harnesses, e.g. lifting straps, with edge protectors or similar protective devices if necessary.

#### ⚠ DANGER

**If the hoists and harnesses fail and cause the truck to fall, the consequences are potentially fatal!**

- Use only hoists and harnesses with sufficient load capacity for the determined loading weight.
- Use only the truck's designated lifting points.
- Make sure that harnesses, such as hooks, shackles, belts etc., are only used in the indicated load direction.
- The harnesses must not be damaged by truck parts.

#### **i** NOTE

*The lifting points are indicated by a hook symbol.*

- Loop the lifting straps around the main traverse (3) on the outer mast of the lift mast as shown.

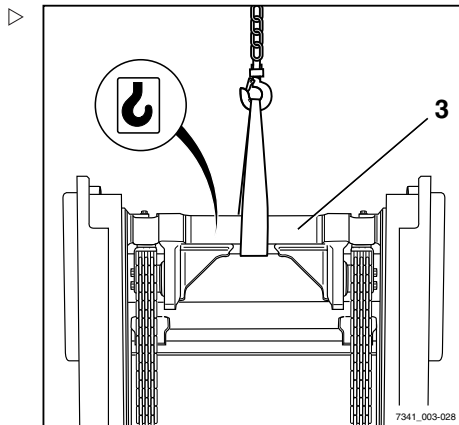

Operating in special operating situations

- Loop the lifting straps around the counterweight (4) as shown.
- Determine the truck's centre of gravity, see "Dimensions" chapter.

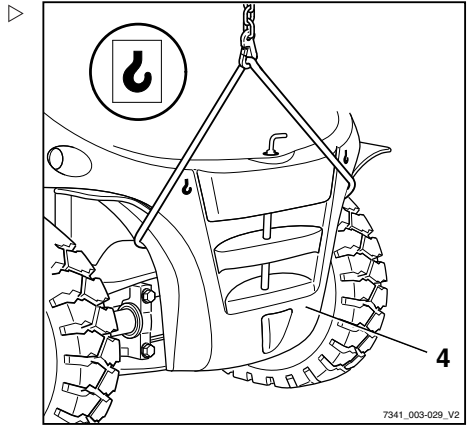

- Adjust the length of the harnesses so that the lifting eye (6) is vertically above the truck's centre of gravity.

This ensures that the truck hangs level when lifted.

- Attach the lifting straps to the lifting eye and insert the safety device (5).

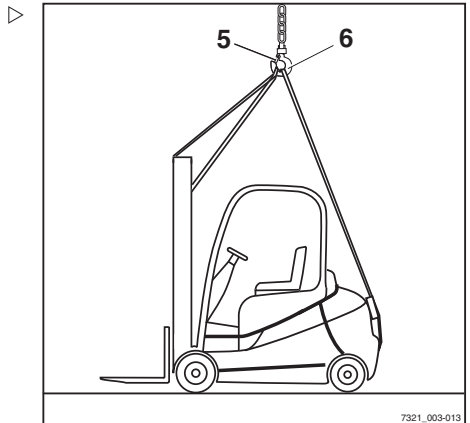

**⚠ CAUTION**

Incorrectly fitted harnesses may damage attachment parts!

Pressure from the harnesses can damage or destroy attachment parts when the truck is lifted. If attachment parts are in the way (e.g. lighting, rear window, trademark emblem etc.), these must be removed before loading.

- Secure harnesses in such a way that they do not touch any attachment parts.
- Check that harnesses cannot collide with attachment parts.

## Operating in special operating situations

### Loading the truck



#### **⚠ DANGER**

**If the raised truck swings in an uncontrolled fashion, it may crush people. There is a risk to life!**

- Never walk or stand underneath suspended loads.
- Do not allow the truck to bump into anything whilst it is being lifted, or allow it to move in an uncontrolled way.
- If necessary, hold the truck using guide ropes.

- Carefully lift the truck and set it down at the intended location.

### Jump-starting



#### **NOTE**

A 12-V power source (e.g. second forklift truck of the same type) must be available.

#### **⚠ WARNING**

Risk of short circuit if the jump leads are connected or disconnected in the incorrect order!

If the batteries' negative terminals are connected to the negative cable, both bodies are also conductively connected to one another. If the positive cable touches one of the two bodies as connection continues, a short circuit can occur.

- Ensure that the correct order is followed when connecting and disconnecting the jump leads.
- Remove the side cover; refer to the section entitled "Attaching and removing the left side cover".
- Leave the engine of the current-giving truck to run.

#### **Connecting the jump leads:**

- Connect the positive cable (2) to the positive terminal on the discharged battery.
- Connect the positive cable to the positive terminal on the current-giving battery.

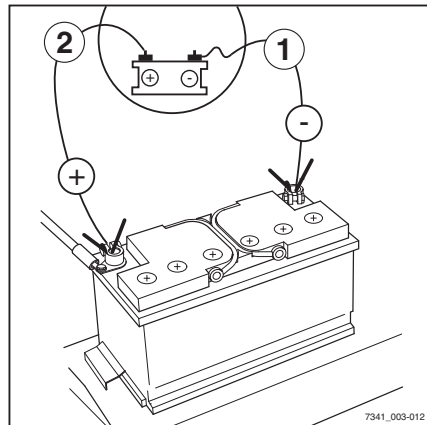

7341\_003-012

- Connect the negative cable (1) to the negative terminal on the current-giving battery.
- Connect the negative cable to the negative terminal on the discharged battery.

**⚠ CAUTION**

The vibrations produced when the engine is started can cause the jump leads to slip off. There is a risk of short circuit!

- Before starting the engine, check that the jump leads are connected securely.

- Start the engine.

**Disconnecting the jump leads:**

- Disconnect the negative cable (1) from the negative terminal on the discharged battery.
- Disconnect the negative cable from the negative terminal on the current-giving battery.
- Disconnect the positive cable (2) from the positive terminal on the discharged battery.
- Disconnect the positive cable from the positive terminal on the current-giving battery.

** NOTE**

*Leave the engine to run because the battery is not yet sufficiently charged.*

- Reattach the side cover.

## Procedure in emergencies

## Procedure in emergencies

## Emergency shutdown

The emergency off switch (1) is used for the emergency shutdown. The emergency off switch may be used to carry out function checking and to shut down the truck safely.

 **NOTE**

*Only trucks with a joystick 4Plus (variant) have an emergency off switch.*

 **WARNING**

No electric braking assistance is available when the emergency off switch is actuated!

Actuating the emergency off switch will de-energise the drive unit. The truck will not be held on a slope by the electric brake.

- Only use the emergency off switch in the event of danger, to carry out function checking or to park the truck safely.
- To brake, actuate the service brake.

 **WARNING**

There is no power steering when the emergency off switch is actuated!

The truck is equipped with a hydraulic power steering system. When the emergency off switch is actuated, the hydraulic system is completely shut down. Steering forces are increased by the remaining emergency steering function.

- Only use the emergency off switch in the event of a fire risk, to carry out function checking or in order to park the truck safely.
- Steer with a higher level of force.

 **NOTE**

*Actuating the emergency off switch also switches off the electric brake, the hydraulic system and the drive unit.*

**In drive mode, this has the following effect:**

- No reduction in truck speed when the accelerator pedal is released, according to the drive programme selected. The truck will coast
- The electric brake does not function during the first part of brake pedal travel. To brake

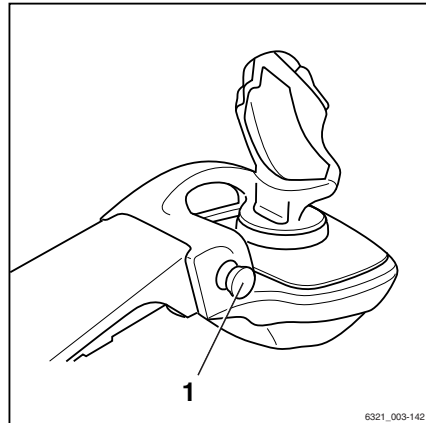

6321\_003-142



- the truck using the mechanical brake, the brake pedal must be pushed down further
- The truck can only be held on a slope using the mechanical brake, not the electric brake
- No power steering effect. Steering forces are increased by the remaining emergency steering function
- The "Curve Speed Control" system (automatic reduction of truck speed when cornering) does not function. The truck must be decelerated with the mechanical brake by pressing the brake pedal
- No hydraulic functions are available
- Press the emergency off switch (1).

The truck will roll to a stop in drive mode.

- Brake the truck to a standstill by actuating the brake pedal.

## Procedure if truck tips over

### **⚠ DANGER**

**If the truck tips over, the driver could fall out and slide under the truck with potentially fatal consequences. There is a risk to life.**

Failure to comply with the limits specified in these operating instructions, e.g. driving on unacceptably steep gradients or failing to adjust speed when cornering, can cause the truck to tip over. If the truck starts to tip over, do not leave the truck under any circumstances. This increases the danger of being hit by the truck.

- Do not release your seat belt.
- Never jump off the truck.
- You must adhere to the rules of behaviour if the truck tips over.

### **Rules of behaviour if truck tips over:**

- Hold onto the steering wheel with your hands.
- Brace your feet in the footwell.
- Bend your upper body over the steering wheel.
- Bend your body against the direction of the fall.



## Procedure in emergencies

### Emergency hammer

The emergency hammer is used to rescue the driver if he is shut inside the cab in a hazardous situation, for example if the truck has toppled over and the cab door cannot be opened.

Single-pane safety glass can be struck relatively safely using the emergency hammer in order for the driver to escape or be rescued from the danger area.

#### Using the emergency hammer

##### **⚠ WARNING**

When glass is smashed there is a risk of injury caused by glass splinters!

When the cab glass is smashed, splinters of glass can shoot into the face and cause damage to skin and eyes through cuts. When a pane of glass is smashed, the face should be turned away and covered with the crook of the free arm.

- Protect the face when smashing a pane of glass.
- 
- Pull the emergency hammer out of its support mounting at the handle.
  - Using one of the two metal tips on the head of the emergency hammer, hit the pane of glass with force until it breaks.

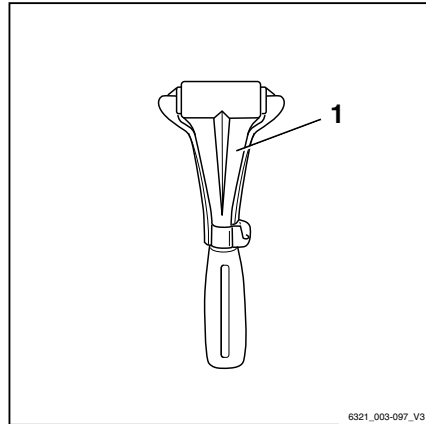

6321\_003-097\_V3

### Emergency lowering

If the hydraulic controller fails whilst a load is raised, emergency lowering can be performed. An emergency lowering screw for this purpose is located on the control block.



##### **⚠ DANGER**

**There is a risk to life from falling loads or if parts of the truck are being lowered.**

- Do not walk beneath the raised load.
- Follow the steps described below.

**⚠ WARNING**

The load is lowered!

The lowering speed is regulated by unscrewing the emergency lowering screw.

- Note the following list.

**Remember the following:**

- Tightening torque:  
max. 2.5 Nm
- When unscrewed a little:  
The load lowers slowly
- When unscrewed a lot:  
The load lowers quickly

**i NOTE**

*A hexagon socket wrench is located beneath the bottom plate on the brake valve for carrying out the steps detailed below. This hexagon socket wrench must remain in the truck at all times.*

- Remove the bottom plate
- Take the Allen key (1) out of the support mounting.
- Open the front right cover.

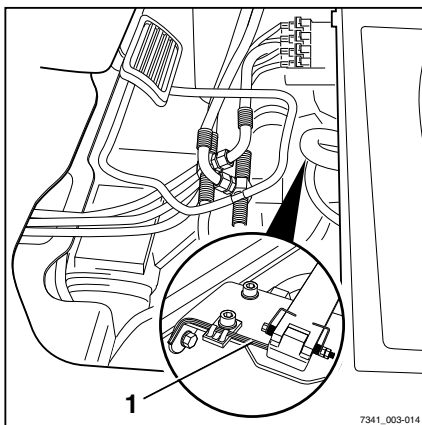

7341\_003-014

## Procedure in emergencies

- Loosen the emergency lowering screw (3) ▷ on the control block (2) a maximum of 1.5 revolutions using the Allen key.
- Screw the emergency lowering screw back in after the load is lowered.
- Return the Allen key to the support mounting provided.
- Install the bottom plate.
- Close the front right cover.

### **⚠ DANGER**

**If the truck is operated with the hydraulic controller blocked, there is an increased risk of accidents!**

- After the emergency lowering procedure, have the malfunction rectified.
- Notify the authorised service centre.

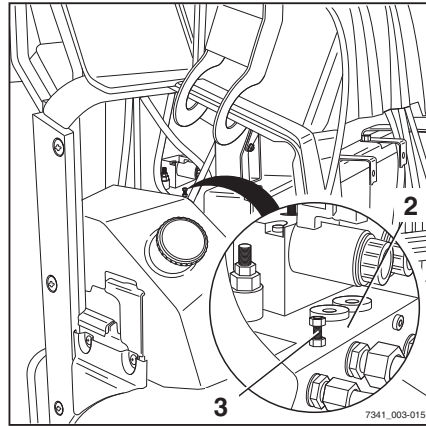

## Releasing the spring-operated brake

### **⚠ CAUTION**

Component damage as a result of blocked brakes!  
In order to tow the truck, the multi-disc brakes must not be blocked in the wheel drive units.

- Repeatedly release the spring-operated brake during the towing process, in accordance with the table below.

The truck is equipped with a negative spring-operated brake. Switching off the engine will block the multi-disc brakes in the wheel drive units after a few minutes. However, the truck can still be moved until the drive wheel units are blocked. In order to tow the truck, the spring-operated brake must be released by actuating the brake valve. Otherwise, the truck is towed with the wheels blocked.

### **i NOTE**

*The brake valve is installed in front of the driver's seat beneath the bottom plate.*

The coupling pin from the counterweight can be used as an aid to actuate the brake valve. If there is no removable coupling pin available on the truck, for example, if the

truck is equipped with automatic tow coupling (variant), the bottom plate must be raised completely in order to access the brake valve.

Once the spring-operated brake is released, the pressure gradually drops again in the brake hydraulics and the brakes can block again. The towing process must be interrupted at certain times and the spring-operated brake released again, in accordance with the table below.

Hydraulic oil temperature	Period after releasing the spring-operated brake until it is blocked once again	
	Minutes	Seconds
-20 °C	190	0
20	7	40
50	2	50
95	1	50

**Actuate the brake valve by means of a coupling pin:**

- Take the coupling pin out of the counterweight.
- Grip the rubber tab in the rubber mat using the finger opening and pull up the tab.

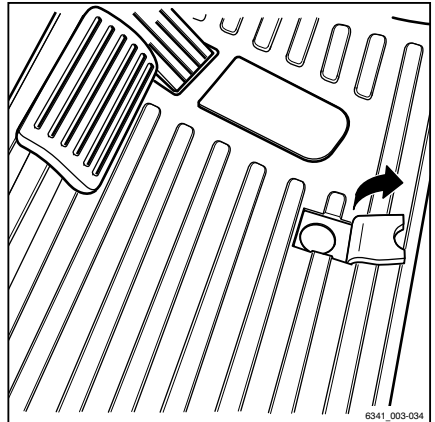

## Procedure in emergencies

- Insert the coupling pin (1) into the bore (2) on the bottom plate until the pin noticeably rests on the brake valve plate beneath.
- Repeatedly press the coupling pin down vertically.

The spring-operated brake is released.

### NOTE

*To fully release the spring-operated brake, press down on the brake valve plate at least 30 times. The pressure that builds up in the brake hydraulics as a result releases the spring-operated brake.*

- Once the spring-operated brake is released, fold the rubber tab in the rubber mat back down.
- Insert the coupling pin in the counterweight.

### Actuate the brake valve without a coupling pin:

- Remove the rubber mat.
- Remove the bottom plate.
- Press the brake valve plate (3) down repeatedly.

The spring-operated brake is released.

### NOTE

*To fully release the spring-operated brake, press down on the brake valve plate at least 30 times. The pressure that builds up in the brake hydraulics as a result releases the spring-operated brake.*

- After releasing the spring-operated brake, re-install the bottom plate and the rubber mat.

### WARNING

Risk of injury through falling or slipping!

If the bottom plate is not inserted, there is a danger of shoes getting stuck, causing you to fall. Even when the bottom plate is installed, there is still a danger of slipping and injury if the rubber mat is not used.

- Install the bottom plate and rubber mat.

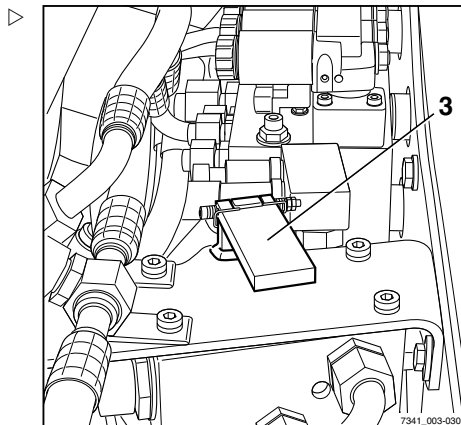
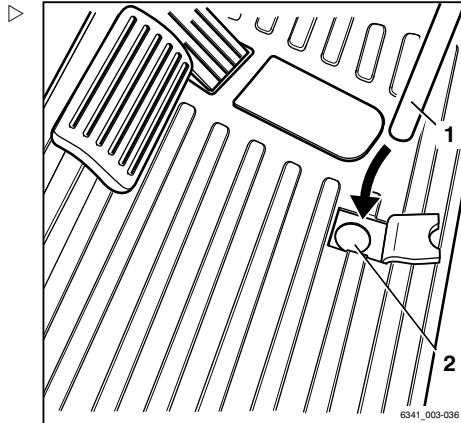

## Disconnecting the battery

Proceed as follows to disconnect the battery:

- Remove the side cover, see ⇒ Chapter "Removing and attaching the left side cover", P. 6-322.
- Loosen the screw joint (2) of the battery-terminal clip (1) on the negative terminal (3).
- Lift the battery-terminal clip off the battery negative terminal and place it to the side.

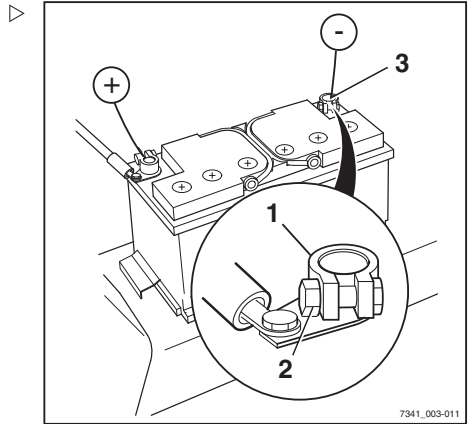

## Refuelling

### Diesel fuel — Specifications

#### ⚠ CAUTION

Risk of component damage if non-approved fuels are used!

Use only approved fuels with the following specifications.

If non-approved fuels are used, compliance with specified emission values and the service life of the engine cannot be guaranteed! This truck is equipped with an engine that fulfils the requirements of the EU level IIIB and US EPA interim Tier 4 standards, and also with an exhaust gas follow-up treatment concept in the form of a particle filter (DPF).

The truck may be operated only with sulphur-free diesel fuels as defined by the following standards:

- EN 590
- ASTM D 975 Grade 2-D S15
- ASTM D 975 Grade 1-D S15
- or non-road fuels (light fuel oils) in line with the EN 590 standard

## Refuelling

If these fuel types are not used, compliance with specified emission values and the service life of the engine cannot be guaranteed.

Minimum requirements for fuels in countries in which none of the approved diesel fuels are available can be requested from the authorised service centre. The operating company is obligated to check the permissibility of the fuel used in accordance with national regulations.

The following is not permitted:

- Admixtures of petroleum, kerosene or additional fluidity additives
- Distillate fuels for marine engines
- Jet fuels
- Biodiesel fuels
- US fuels in line with the ASTM D 975 1-D S500 or ASTM D 975 2-D S500 standards
- If necessary, query with the authorised service centre.

The following limits in accordance with EN 590 must be complied with (amongst other things):

Parameter	Unit	Value
Cetane number <sup>1)</sup>	-	Min. 51
Density at 15 C	kg/m <sup>3</sup>	820–845
Sulphur content	mg/kg	Max. 10

<sup>1)</sup> The use of diesel fuels with a lower cetane number can lead to white smoke development and misfiring. In winter, the use of diesel fuels with a higher cetane number is recommended.

### Sulphur content in the diesel fuel

#### CAUTION

Insufficient lubrication can lead to engine damage!

- Use only sulphur-free diesel fuels in accordance with manufacturer specifications.

Insufficient lubrication capacity in diesel fuels with a sulphur content > 500 mg/kg can lead



to serious problems through wear, above all in common rail injection systems. In sulphur-free diesel fuels in accordance with EN 590 and ASTM D 975, sufficient lubrication capacity is guaranteed with corresponding fuel additives during refining.

Fuels with a sulphur content > 0.5% (m/m) require a shortened lubricating oil change interval and must not be used in engines with a particle filter system. Fuels with a sulphur content > 1.0% (m/m) are also not permissible due to high corrosion and significant lifetime reduction of the engine.

### Winter operation with diesel fuel

#### CAUTION

Adding petrol can lead to malfunctions in the fuel injection system!

- Do not add petrol.
- Do not add petroleum, kerosene or additional fluidity additives.
- If necessary, query with the authorised service centre.

In winter operation, special demands are placed on the low-temperature performance of fuels. Generally, diesel fuels that can be used at temperatures down to -44 C are available on the open market. Therefore, it is not necessary to add additives to improve the fluidity. Adding petrol can lead to the formation of vapour pockets (cavitation) in the fuel system. This disrupts the function of the fuel injection system and, if done over a long period, can lead to component damage.

### Non-road fuels

#### NOTE

*In some European countries, non-road-fuels are defined with the same characteristics as light fuel oil. The permissibility as a fuel is handled differently in the individual countries. Light fuel oils and non-road-fuels are suitable*

## Refuelling

*for the engine if all limits of EN 590 are complied with.*

- *Use only sulphur-free diesel fuels in accordance with manufacturer specifications.*
- *The operating company is obligated to check the permissibility of the fuel used in accordance with national regulations.*

## Filling up with diesel fuel

### ⚠ CAUTION

Lack of fuel can cause malfunctions!

If the fuel tank has been run empty, the fuel injection system can draw in air bubbles. This can lead to malfunctions in the fuel injection system. When the fuel tank is replaced during repair work or because it has been run empty, diesel fuel must be pre-pumped with the fuel hand pump after filling, see the "Using the fuel hand pump" chapter.

- Never run the fuel tank empty.
- Refuel truck and pre-pump diesel fuel.

The fuel reserve is shown by the fuel level indicator (1) flashing on the display screen of the display and operating unit.



### ⚠ DANGER

**There is a risk of fire when filling up with diesel fuel.**

- Turn off the engine before filling up.
- When refuelling, smoking or the use of an open flame is strictly forbidden!
- Comply with the legal provisions for handling diesel fuel.
- Observe safety regulations for handling diesel fuel, see the "Diesel fuel" chapter.

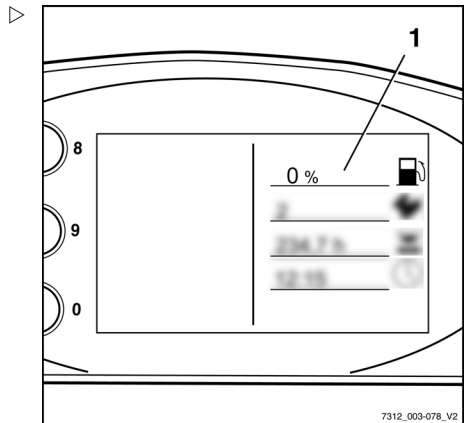

7312\_003-078\_V2

### ⚠ CAUTION

Use of non-permissible fuels can lead to engine damage!

- Use of fuel additives supporting soot burn-off is not permitted.
- Starting aids (such as "Startpilot" or similar) must not be used.
- In low temperatures use winter diesel.
- The truck may only be operated with diesel fuel in accordance with manufacturer specifications, see the "Diesel fuel — Specifications" chapter.

The fuel-tank filler neck is located on the right-hand side in the drive direction, on the mudguard of the front wheel.

## Refuelling

- Turn the locking cap (2) at the filler neck to the left and remove.
- Fill up with clean diesel fuel, for the maximum filling quantity see the "Maintenance data table" chapter.
- Place the locking cap onto the filler neck and turn completely to the right.

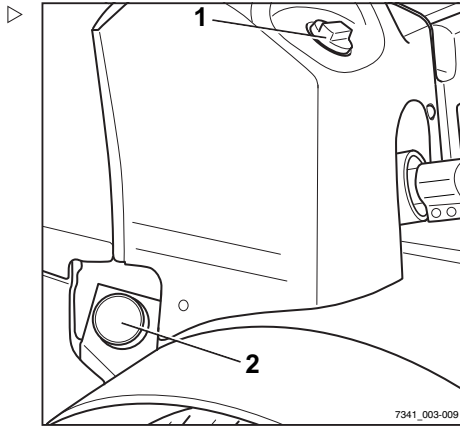

## Using the fuel hand pump

### ⚠ CAUTION

Lack of fuel can cause malfunctions!

If the fuel tank has been run empty, the fuel injection system can draw in air bubbles. This can lead to malfunctions in the fuel injection system.

- Never run the fuel tank empty.
- Refuel truck and pre-pump diesel fuel.

The fuel hand pump (2) is located on the fuel filter (1) beneath the right service flap. ▷

If the fuel tank was complete empty, it is possible that the fuel cannot be supplied by the fuel pump alone after refuelling. Use the fuel hand pump to pre-pump fuel into the system until the fuel pump reaches sufficient supply power. The fuel hand pump must be used, for example, after the tank has been run empty, after initial filling or after draining for repair work.

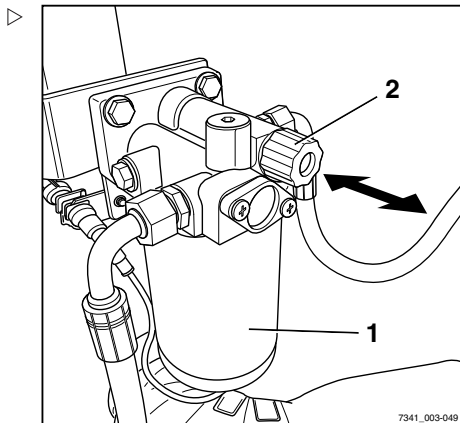

- Open the service flap (1) on the right.

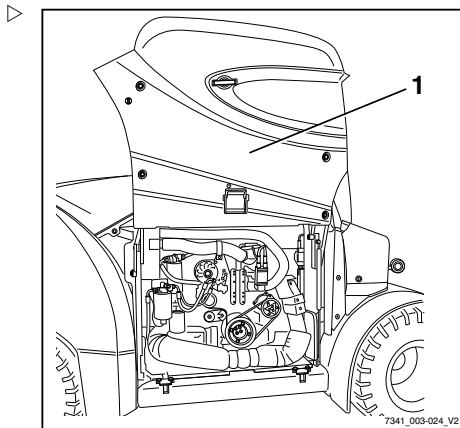

- To pump, pull the fuel hand pump (2) out and push it in again ten times.

**i** NOTE

*A light hissing sound you may hear indicates that the fuel is flowing and is not a fault on the truck.*

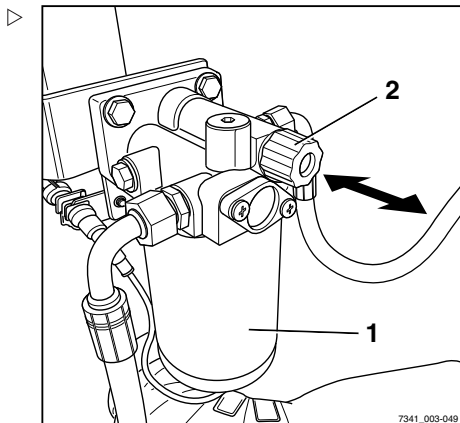

## Refuelling

**Topping up AdBlue**

The AdBlue filler neck is located on the front right-hand side of the truck, above the diesel filler neck (2).

It is recommended that the AdBlue tank be refilled with AdBlue every time the diesel fuel is topped up.

- Turn the locking cap (1) of the AdBlue filler neck to the left and remove.
- Add AdBlue.

The AdBlue tank holds a maximum of 10 l.

- Place the locking cap onto the AdBlue filler neck and turn completely to the right.

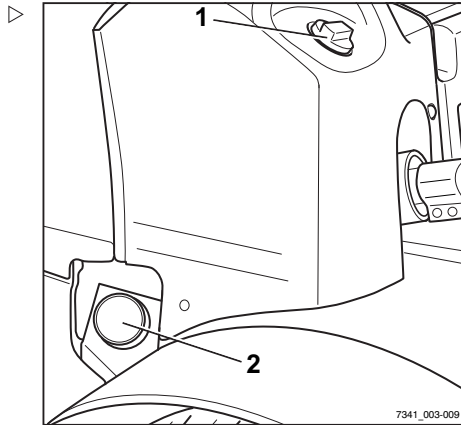

## Decommissioning

### Parking the truck securely and switching it off



#### **⚠ DANGER**

**Risk of fatal injury from being run over if the truck rolls away!**

- The truck must not be parked on a slope.
- In emergencies, secure the truck using wedges on the side facing downhill.
- Only leave the truck when the parking brake has been applied.

#### **⚠ DANGER**

**There is a risk of fatal injury from a falling load or parts of the truck being lowered!**

- Lower the load fully before leaving the truck.
- Apply the parking brake.
- Lower the fork carriage to the ground.
- Tilt the lift mast forwards until the tips of the fork arms rest on the ground.
- If attachments (variant) are fitted, retract the working cylinders; see the chapter entitled "General instructions for controlling attachments".
- Take your foot off the accelerator pedal and allow the engine to continue idling for a short while.
- Turn the switch key to the left and remove it.
- If fitted, press the emergency off switch; see the chapter entitled "Emergency shutdown".

#### **i NOTE**

*Switch keys, FleetManager cards (variant), FleetManager transponder chips (variant) and the PIN code for access authorisation (variant) must not be handed over to other persons unless explicit instructions to this effect have been given.*



5060\_003-130

## Decommissioning

**Wheel chock (variant)**

The wheel chock (variant) is used to prevent the truck from rolling away on a slope.

- Lift handle (2) on the support mounting.
- Remove wheel chock (1) from the support mounting.
- Push the wheel chock under a front axle wheel on the side facing the downhill slope.

**NOTE**

*After use, return the wheel chock to the support mounting and press the handle (2) down again.*

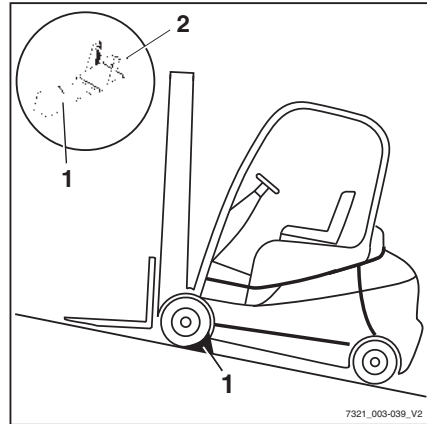
**Shutting down and storing the truck****⚠ CAUTION**

Component damage due to incorrect storage!

If the truck is stored or shut down incorrectly for more than two months, it may suffer corrosion damage. If the truck is parked in an ambient temperature of less than  $-10^{\circ}\text{C}$  for an extended period, the battery will cool down. The electrolyte may freeze and damage the battery.

- Carry out the following measures before shut-down.

**⚠ CAUTION**

Danger of tyre deformation by continuously loading on one side!

Have the truck raised and jacked up by the authorised service centre so that all the wheels are clear of the ground. This prevents permanent deformation of the tyres.

**⚠ CAUTION**

Danger of damage from corrosion due to condensation on the truck!

Many plastic films and synthetic materials are watertight. Condensation water on the truck cannot escape through these covers.

- Do not use plastic film as this encourages the formation of condensation water.



 **NOTE**

*Store only fully charged batteries.*

**Measures before shutdown**

- Store the truck in a dry, clean, frost-free and well ventilated environment.
- Clean the truck thoroughly; see the chapter entitled "Cleaning".
- Lift fork carriage to full extent several times.
- Tilt the lift mast forwards and backwards several times and, if fitted, move attachment repeatedly.
- To relieve the strain on the load chains, lower the fork onto a suitable supporting surface, e.g. a pallet.
- Check the hydraulic oil level and top up if required.
- Apply oil or grease thinly to all uninsulated moving parts.
- Lubricate the forklift truck.
- Lubricate the joints and controls.
- Fill the fuel tank.
- Remove the battery and store in a warm and dry location.
- Regularly check the charge state of the battery and recharge if necessary.
- Apply a suitable contact spray to all exposed electrical contacts.
- Preserve the engine as specified by the manufacturer.
- Cover the truck with vapour permeable materials, such as cotton, in order to protect against dust.
- If the truck is to be shut down for even longer periods, contact your authorised service centre to find out about additional measures.

## Decommissioning

### Recommissioning after shutdown

If the truck has been shut down for longer than six months, it must be carefully checked before being recommissioned. As in the annual inspection, this check should also include all safety items for the truck.

- Clean the truck thoroughly; see chapter "Cleaning".
- Oil joints and controls.
- Check battery condition and acid density, and recharge if necessary.
- Restore engine to normal condition according to regulations of engine manufacturer.
- Check the engine oil for condensation water and replace if necessary.
- Check the hydraulic oil for condensation water and replace if necessary.
- Perform the same maintenance tasks as before initial commissioning.
- Put the truck into operation.

During commissioning, the following must be checked in particular:

- Drive, controller, steering
- Brakes (service brake, parking brake)
- Lifting system (lifting accessories, load chains, mounting)



#### NOTE

*For further information, see the truck workshop manual or contact the authorised service centre.*

## Cleaning

### Cleaning the truck

- Park the truck securely.



#### **⚠ WARNING**

There is a risk of injury due to falling when climbing onto the truck!

When climbing onto the truck, you can get stuck or slip on components and fall. Higher points on the truck may only be made accessible with corresponding devices.

- Adhere strictly to the following steps.

- For climbing onto the truck, use only the steps provided for this purpose.
- For reaching inaccessible places, use devices such as stepladders or platforms.

#### **⚠ CAUTION**

If water penetrates the electrical system, there is a risk of short circuit!

- Adhere strictly to the following steps.
- Before cleaning, switch the electrical system off so that there is no voltage.
- Do not spray drive units and electrical components or their covers directly with water.

#### **⚠ CAUTION**

Failure to follow these instructions could result in damaged components!

The engine must be switched off during washing.

Water should not be used for cleaning the area around the central electrical system; instead, only clean with a dry cloth or clean compressed air.

#### **⚠ CAUTION**

Excessive water pressure or water and steam that are too hot can damage truck components.

- Adhere strictly to the following steps.
- Only use high-pressure cleaners with a maximum output power of 50 bar and at a maximum temperature of 85°C.

## Cleaning

- When using high-pressure cleaners, make sure there is a distance of at least 20 cm between the nozzle and the object being cleaned.
- Do not aim the cleaning jet directly at adhesive labels or decal information.



### **⚠ DANGER**

#### **Risk of fire!**

Deposits/accumulations of combustible materials may ignite in the vicinity of hot components (e.g. exhaust pipes).

- Adhere strictly to the following steps.

- Regularly remove all deposits/accumulations of foreign materials in the vicinity of hot components.
- Do not place combustible materials in the engine compartment.



### **⚠ DANGER**

**Flammable fluids can be ignited by hot components on the truck, causing a risk of fire!**

- Adhere strictly to the following steps.

- Do not use flammable fluids for cleaning.
- Observe the manufacturer's guidelines for working with cleaning materials.

### **⚠ CAUTION**

Abrasive cleaning materials can damage component surfaces!

Using abrasive cleaning materials that are unsuitable for plastics may dissolve plastic parts or make them brittle. The display and operating unit screen may become cloudy.

- Adhere strictly to the following steps.
- Clean plastic parts with plastic cleaning materials only.
- Observe the manufacturer's guidelines for working with cleaning materials.

### Washing the truck exterior

- Clean the truck exterior with water-soluble cleaning materials and water (water jet, sponge, cloth).
- Clean all walk-in areas, the oil filling openings and their surroundings, and the lubricating nipples before lubricating.

#### NOTE

*Please note: The more often the truck is cleaned, the more frequently it must be lubricated.*

### Cleaning the electrical system



#### CAUTION

Cleaning electrical system parts with water can damage the electrical system.

- Cleaning electrical system parts with water is forbidden!
  - Use dry cleaning materials in accordance with the manufacturer's specifications.
  - Do not remove covers etc.
- 
- Clean the electrical system parts with a metal-free brush and blow the dust off with low-pressure compressed air.

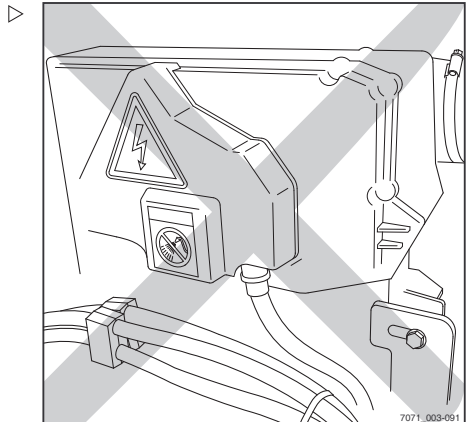

## Cleaning

### Cleaning load chains

#### ▲ WARNING

Risk of accident!

Load chains are safety elements.

The use of cold/chemical cleaners or fluids that are corrosive or contain acid or chlorine can damage the chains and is forbidden!

- Observe the manufacturer's guidelines for working with cleaning materials.
- 
- Place a collection vessel under the lift mast.
  - Clean with paraffin derivatives, such as benzene.
  - When using a steam jet, do not use additional cleaning agents.
  - Remove any water in the chain links using compressed air immediately after cleaning. Move the chain several times during this procedure.
  - Immediately after drying the chain, spray it with chain spray. Move the chain several times during this procedure.

For chain spray specifications, see the "Maintenance data table" chapter.

#### ◆ ENVIRONMENT NOTE

*Dispose of any fluid that has been spilled or collected in the collection vessel in an environmentally friendly manner. Follow the statutory regulations.*

### Cleaning the windows

Any panes of glass, e.g. cab windows (variant), must always be kept clean and free of ice. This is the only means of guaranteeing good visibility.

#### ▲ CAUTION

Do not damage the rear window heater (inside)!

- Take great care when cleaning the rear window and do not use any objects with sharp edges.

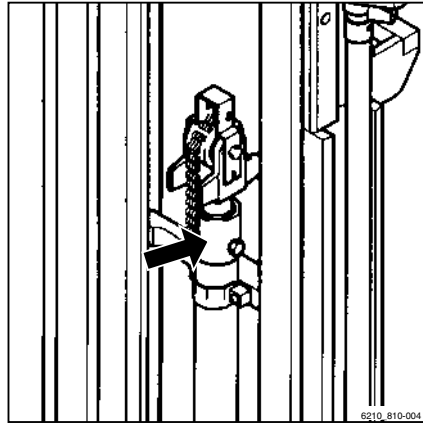

- Clean the windows using a commercially available glass cleaner.

### After washing

- Carefully dry the truck (e.g. with compressed air).
- Sit on the driver's seat and start up the truck in accordance with regulations.

#### **⚠ CAUTION**

Risk of short circuit!

- If any moisture has penetrated into the engine despite the precautionary measures taken, this must first be dried with compressed air.
- The truck must then be started up to prevent possible corrosion damage.

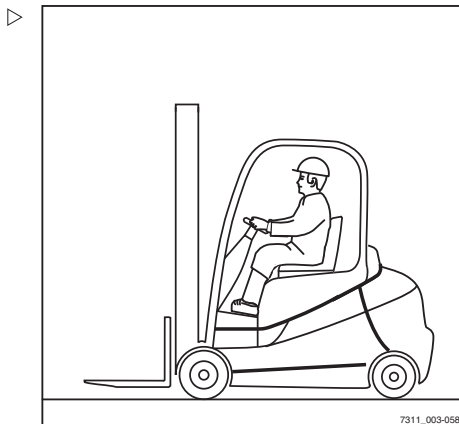





6

---

## Maintenance

## General maintenance information

# General maintenance information

## Personnel qualifications

Only qualified and authorised personnel are allowed to perform maintenance work. The annual testing must be carried out by a qualified person. The examination and assessment of the qualified person must be unaffected by operational and economic conditions and must be conducted solely from a safety perspective. They must have sufficient knowledge and experience to be able to assess the condition of a forklift truck and the effectiveness of the protective equipment in accordance with technical conventions and the principles for testing forklift trucks.

## Maintenance work without special qualifications

Simple maintenance work, e.g. checking the hydraulic oil level, may be carried out by untrained personnel. A qualification, like that of a specialist, is not required to carry out this work. The required operations are described in sufficient detail in the corresponding places in these operating instructions.

## Information for carrying out maintenance

This section contains all information required to determine when the truck needs maintenance. Carry out maintenance work within the time limits according to the hour meter and using the following maintenance check lists. This is the only way to ensure that the truck remains ready for operation and provides optimal performance and service life. It is also a precondition for any warranty claims.

### Maintenance timeframe

- Carry out maintenance work on the truck in accordance with the "Service in" display (1).
- The maintenance check lists indicate the maintenance work that is due.

The intervals are defined for standard use. Shorter maintenance intervals can be defined in consultation with the operating company, depending on the application conditions of the truck.

The following factors may necessitate shorter maintenance intervals:

- Contaminated, poor quality roads
- Dusty or salty air
- High levels of air humidity
- Extremely high or low ambient temperatures, or extreme changes in temperature
- Multi-shift operation with a high duty cycle
- Specific national regulations for the truck or individual components

#### **⚠ CAUTION**

Risk of component damage!

Any deviating technical information in these operating instructions takes precedence over the information in the original engine operating instructions.

- If you have any questions, please contact your authorised service centre.

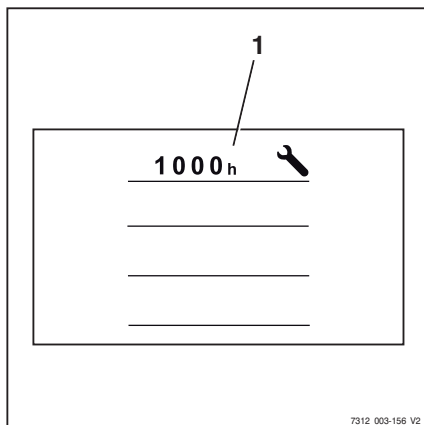

General maintenance information

## Maintenance instructions

Maintenance work must be carried out in accordance with the following maintenance intervals. The intervals are designed for standard use. Depending on the application conditions of the truck, shorter maintenance intervals can be set, on agreement with the operating company.

These factors may call for shorter maintenance intervals:

- Contaminated, poor quality roads
- Dusty or salty air
- High air humidity
- Extremely high or low ambient temperatures, or extreme changes in temperature
- Multi-shift operation with a high duty cycle
- Specific national regulations for the truck or individual components

For maintenance tasks, only use original spare parts, and only use consumables that have been prescribed in the overview of consumables.

### Maintenance - 500 hours/half-yearly

At operating hours								Carried out		
500		1000		1500		2000		2500	✓	*
<b>Exhaust system</b>										
Replace the filter in the AdBlue dosing module.										



## Maintenance - 1000 hours/annually

At operating hours								Carried out			
1000		2000		4000		5000		7000			
8000		10000		11000		13000		14000			
										✓	*
<b>Chassis, bodywork and fittings</b>											
Check chassis for cracks											
Check overhead guard/cab and panes of glass for damage											
Check controls, switches and joints for damage, and apply grease and oil											
Check driver's seat for correct function and for damage											
Check driver restraint system for correct function and for damage, and clean.											
Check the dual pedal variant for damage and correct function, and lubricate											
<b>Tyres and wheels</b>											
Check tyres for wear and check the air pressure if necessary											
Check wheels for damage and check the tightening torques											
<b>Power unit</b>											
Check the mounting of the drive axle and check the drive axle for leaks.											
Check cooling system for leaks and check water pumps for correct function											
Check gearbox oil level											
Change gearbox oil (once after 1000 hours)											
<b>Internal combustion engine</b>											
Check condition of the internal combustion engine (visual inspection)											
Check valve clearance and adjust if necessary (every 2000 hours)											
Change engine oil and oil filter											
Check the air filter and the microfilter, and replace if necessary											
Check cooling system for leaks and correct function											
Check coolant and top up if necessary											
Check exhaust system											
<b>Fuel system</b>											
Check fuel system for leaks and correct function											
Check fuel pre-filter (water trap) and drain water if necessary											
Replace fuel pre-filter (once a year)											
Replace fuel filter (main filter)											

## General maintenance information

At operating hours								Carried out			
1000		2000		4000		5000		7000		✓	✘
8000		10000		11000		13000		14000			
<b>Steering</b>											
Check steering system for correct function and for leaks											
Check that the steering wheel is firmly attached and check the turning handle for damage											
Steering axle: Check that it is firmly attached, check for leaks, and apply grease											
Check steering stop											
<b>Brake</b>											
Check all mechanical brake parts for condition and correct function											
Check brake valve for correct function and leaks											
Service brake function check											
Parking brake function check											
<b>Electrical system</b>											
Check all power cable connections											
Check switches, transmitters and sensors for correct function											
Check lighting and indicator lights											
<b>Starter battery</b>											
Measure the cold-start current; recharge or replace the battery if necessary.											
<b>Hydraulics</b>											
Check hydraulic system for condition, correct function and leaks											
Check the hydraulics blocking function (ISO valve)											
Check the oil level											
<b>Lift mast</b>											
Check mast bearings for damage and lubricate. Check the tightening torque											
Check mast profiles for damage and wear, and lubricate											
Check load chains for damage and wear. Adjust and lubricate											
Check lift cylinders and connections for damage and leaks											
Check guide pulleys for damage and wear											
Check support rollers and chain rollers for damage and wear											
Check the play between the fork carriage stop and run-out barrier											
Check tilt cylinders and connections for damage and leaks											



At operating hours									Carried out		
1000		2000		4000		5000		7000		✓	*
8000		10000		11000		13000		14000			
Check fork carriage for damage and wear											
Check fork arm interlock for damage and correct function											
Check fork arms for wear and deformation											
Check that there is a safety screw on the fork carriage or on the attachment											
Check the auxiliary hydraulics hoses for damage											
<b>Special equipment</b>											
Heating system: Check fresh air filters and beat out											
Heating system: Check for damage; observe manufacturer's maintenance instructions											
Air conditioning: Check fresh air filter and recirculated air filter, and beat out											
Air conditioning: function check											
Check attachments for wear and damage; observe manufacturer's maintenance instructions											
Check trailer coupling for wear and damage; observe manufacturer's maintenance instructions											
<b>General</b>											
Read out error numbers and delete list											
Reset maintenance interval											
Check labelling for completeness											
Test drive the truck											

General maintenance information

**Maintenance - 3000 hours/every two years**

At operating hours								Carried out		
3000		6000		9000		12000		15000	✓	*
<b>Note</b>										
Perform all 1000-hour maintenance work.										
<b>Power unit</b>										
Change the gearbox oil										
<b>Internal combustion engine</b>										
Internal combustion engine, general overhaul (every 12,000 hours)										
Replace the poly-v belt and tensioning pulleys (every two years)										
Change the air filter and fine filter										
Change coolant (every two years)										
Change the spark plugs at the burner										
Diesel particle filter: Change filter element (every 6000 to 12,000 hours)										
<b>Hydraulics</b>										
Change the hydraulic oil										
Change the return line filter, breather filter and high-pressure filter										
<b>Special equipment</b>										
Air conditioning: Replace the fresh air filter and the recirculated air filter										
Air conditioning: Replace the accumulator dryer and refill with refrigerant										

**Ordering spare parts and wearing parts**

Spare parts are provided by our spare parts service department. The information required for ordering parts can be found in the spare parts list.

Only use spare parts as per the manufacturer's instructions. The use of unapproved spare parts can result in an increased risk of accidents due to insufficient quality or incorrect assignment. Anyone using unapproved spare parts shall assume unlimited liability in the event of damage or harm.

## General maintenance information

### Quality and quantity of the required operating materials

Only the operating materials specified in the maintenance data table may be used.

- The required consumables and lubricants can be found in the maintenance data table.

Oil and grease types of a different quality must not be mixed. This negatively affects the lubricity. If a change between different manufacturers cannot be avoided, drain the old oil thoroughly.

Before carrying out lubricating work, filter changes or any work on the hydraulic system, carefully clean the area around the part involved.

When topping up working materials, use only clean containers!

## Maintenance data table

### General lubrication points

Unit	Operating material	Specifications	Dimensions
Lubrication	High-pressure grease	ID no. 0147873	As required

### Controls/joints

Unit	Operating material	Specifications	Dimensions
Lubrication	High-pressure grease	ID no. 0147873	As required
	Oil	SAE 80 MIL-L2105 API-GL4	As required
Dual-pedal operation	High-pressure grease	ID no. 0147873	As required

### Battery

Unit	Operating material	Specifications	Dimensions
System contents	Distilled water		As required
Insulation resistance		DIN 43539 VDE 0510	Min. 500 $\Omega/V$ against earth

### Electrical system

Unit	Operating material	Specifications	Dimensions
Insulation resistance		DIN EN 1175 VDE 0117	Min. 1000 $\Omega/V$ against earth

### Hydraulic system

Unit	Operating material	Specifications	Dimensions
System contents	Hydraulic oil	HVLP 68 or ISO VG 68 DIN 51524, part 2	Max. 125 l
	Hydraulic oil for the food industry (variant)	USDA H1 DIN 51524	

### Tyres

Unit	Operating material	Specifications	Dimensions
Superelastic tyres	Wear limit		To wear mark
	Minimum tread depth		1.6 mm
Pneumatic tyres	Air pressure		See information on truck
	Minimum tread depth		1.6 mm

## General maintenance information

## AL80-01 steering axle

Unit	Operating material	Specifications	Dimensions
Wheel nuts/screws	Torque wrench	DIN 74361-A 20-10 A2C	640 Nm
Axle stub bearing, spherical bearing	Grease	Aralub 4320 DIN 51825-KPF2N20 ID no. 0148659	Fill with grease until a small amount of fresh grease escapes
Wheel bearing, wheel bearing rotary shaft seal	Grease	DIN 51825-KP2 K-30, lithium-saponified ID no. 0163488	Fill with grease

## AE80-01 drive axle

Unit	Operating material	Specifications	Dimensions
Wheel nuts/screws	Torque wrench	DIN 74361-A 20-10 A2C	640 Nm
Filling incl. service brake	Gearbox oil	SAE 80W-90 API-GL4 ARAL EP Plus 80W-90 BP Energear HT 80W-90 Castrol Syntrex Universal 80W-90	For further information, refer to the workshop manual for the truck in question.

## Lift mast

Unit	Operating material	Specifications	Dimensions
Lubrication	High-pressure grease	ID no. 0147873	As required
Stop	Play		Min. 2 mm
Mast bearing screws	Torque wrench	Cylinder head bolt M24x90-12.9 ISO 4762	1100 Nm

## Load chains

Unit	Operating material	Specifications	Dimensions
Lubrication	High-load chain spray	Fully synthetic Temperature range: -35°C to +250°C ID no. 0156428	As required

**Cooling system**

Unit	Operating material	Specifications	Dimensions
System contents	Corrosion inhibitor and cooling system protecting agent/water	40% coolant/60% water, for frost protection down to -25 C VW G12 plus (violet) TL-VW 774 F	Approx. 42 l

**Air conditioning**

Unit	Operating material	Specifications	Dimensions
System contents	Refrigerant	ID no. 7449600005	1350 g

**Fuel tank**

Unit	Operating material	Specifications	Dimensions
System contents	Diesel fuel	EN 590, DIN 51628, ASTM D975, NATO F-54 non-road fuels (light fuel oils, EN 590 quality)	Approx. 110 l

**Engine**

Unit	Operating material	Specifications	Dimensions
System contents	Engine oil	DQC III-10 LA, DQC IV-10 LA	13 l, with filter change

**Air filter system**

Unit	Operating material	Specifications	Dimensions
Air filter	Filter cartridge and safety cartridge		
Oil-bath air filter	Engine oil	DQC III-10 LA, DQC IV-10 LA	Level mark on the oil tank

**Washer system**

Unit	Operating material	Specifications	Dimensions
System contents	Washer fluid	Winter, ID no. 172566	As required

**Exhaust gas treatment (SCR)**

Unit	Operating material	Specifications	Dimensions
System contents	AdBlue	32.5% urea solution, in accordance with DIN 70070 / ISO 22241	Approx. 10 l

## Safety regulations for maintenance

# Safety regulations for maintenance

## General information

### DANGER

#### **Risk of fatal poisoning!**

It is dangerous to leave the engine running in enclosed spaces. The engine consumes oxygen and emits carbon dioxide, carbon monoxide and other poisonous gases. There is a risk of fatal poisoning!

- Only operate the truck in areas that are well ventilated.

---

To prevent accidents during maintenance work and repair work, all necessary safety measures must be taken, e.g.:

- Apply the parking brake.
- Switch off the key switch and remove the key.
- Ensure that the truck cannot move unintentionally or start up inadvertently.
- If required, have the truck jacked up by the authorised service centre.
- Have the raised fork carriage or the extended lift mast secured against accidental lowering by the authorised service centre.
- Insert an appropriately sized wooden beam as an abutment between the lift mast and the cab, and secure the lift mast to prevent it tilting backwards unintentionally.
- Observe the maximum lift height of the lift mast, and compare the dimensions from the technical data with the dimensions of the hall into which the truck is to be driven. These steps are taken to prevent a collision with the ceiling of the hall and to avoid any damage caused as a result.

## Working on the hydraulic equipment

The hydraulic system must be depressurised prior to all work on the system.



## Working on the electrical equipment

Work may only be performed on the electrical equipment of the truck when it is in a voltage-free state. Function checks, inspections and adjustments on energised parts must only be performed by trained and authorised persons, taking the necessary precautions into account. Rings, metal bracelets etc. must be removed before working on electric components.

To prevent damage to electronic systems with electronic components, such as an electronic driving regulator or lift control, these components must be removed from the truck prior to the start of electric welding.

Work on the electrical system (e.g. connecting a radio, additional headlights etc.) is only permitted with approval from the authorised service centre.

## Working on the ignition system

To prevent personal injury and/or destruction of the ignition system, please observe the following:

- Only connect and disconnect ignition system lines, including high-voltage lines and measuring device lines, with the ignition switched off.
- If the engine is to be operated at starting speed but not actually started (e.g. for a compression pressure test), disconnect the connection assembly from the ignition coil.
- Use of a quick charger to jump start the engine is only permitted for a period of up to 1 minute at max. 16.5 volts.
- The engine may only be washed when the ignition is switched off.
- When performing electric or point welding, completely disconnect the battery.
- Trucks that have a fault in the ignition system, or a suspected fault, may only be towed if the plug is disconnected from the ignition coil.

## Safety regulations for maintenance

### Safety devices

After maintenance and repair work, all safety devices must be reinstalled and tested for operational reliability.

### Set values

The device-dependent set values must be observed when making repairs and when changing hydraulic and electrical components. These are listed in the appropriate sections.

### Lifting and jacking up

#### DANGER

##### **There is a risk to life if the truck tips over!**

If not raised and jacked up properly, the truck may tip over and fall off. Only the hoists specified in the workshop manual for this truck are allowed and are tested for the necessary safety and load capacity.

- Only have the truck raised and jacked up by the authorised service centre.
- Only jack the truck up at the points specified in the workshop manual.

The truck must be raised and jacked up for various types of maintenance work. The authorised service centre must be informed that this is to take place. Safe handling of the truck and the corresponding hoists is described in the truck's workshop manual.

### Working at the front of the truck

#### DANGER

##### **Risk of accident!**

If the lift mast or fork carriage is raised, no work may be performed on the lift mast or at the front of the truck unless the following safety measures are observed.

- When securing, only use chains with sufficient load-bearing capacity.
- Contact the authorised service centre.

**⚠ CAUTION**

Possibility of damage to the ceiling!

- Note the maximum lift height of the lift mast.

**Securing the lift mast against tilting backwards**

A hardwood beam with a cross-section of 120 x 120 mm is required. The length of the hardwood beam must approximately correspond to the width of the fork carriage (b3). To avoid impact injuries, the hardwood beam must not protrude beyond the outer contour of the truck. A maximum length matching the total width (b1) of the truck is recommended.

- Obtain the dimensions (b1) and (b3) from the corresponding VDI datasheet.
- Clamp the hardwood beam (1) between the driver protection structure (2) and the lift mast (3).

**Removing the lift mast****⚠ DANGER****Risk of accident!**

This work must only be performed by an authorised service technician.

- Arrange for an authorised service technician to remove the lift mast.

**Securing the lift mast against falling off****⚠ DANGER****Risk of accident!**

This work must only be performed by an authorised service technician.

- Arrange for an authorised service technician to secure the lift mast.

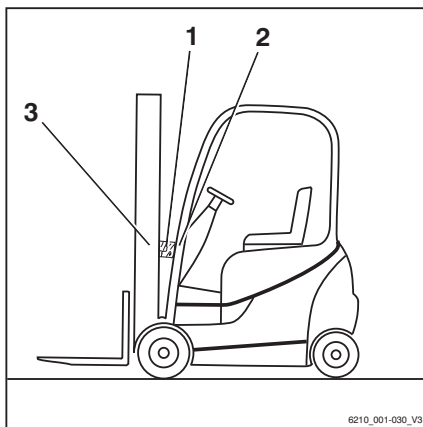

## Providing access to maintenance points

### Providing access to maintenance points

#### Opening the bonnet

##### ⚠ WARNING

Risk of injury!

- Switch off the engine before opening the bonnet!

##### ⚠ CAUTION

When opening the bonnet, the driver's seat may be damaged if it is not moved as far forwards as possible.

- Slide the driver's seat all the way forwards.
- Move the steering column (1) as far forwards as possible and secure; see ⇒ Chapter "Adjusting the steering column", P. 5-80.
- Slide the driver's seat (2) all the way forwards; see ⇒ Chapter "Adjusting the MSG 65/MSG 75 driver's seat", P. 5-76.
- For trucks with a rear window (variant), fold the seat backrest forwards; see ⇒ Chapter "Adjusting the MSG 65/MSG 75 driver's seat", P. 5-76. Remove all protruding objects from the shelf.
- Firmly insert a narrow screwdriver into the slot (4) of the bonnet release until the interlock opens. In an emergency, the ignition and stop key can also be used for this purpose.
- Use the handle to open the bonnet.

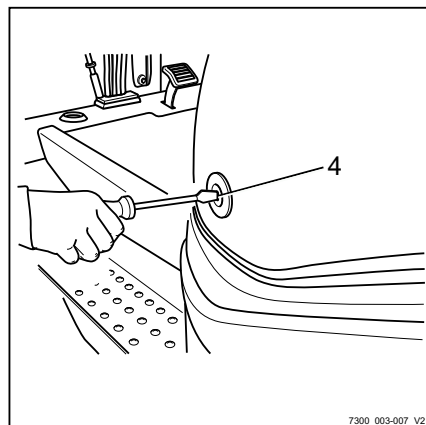
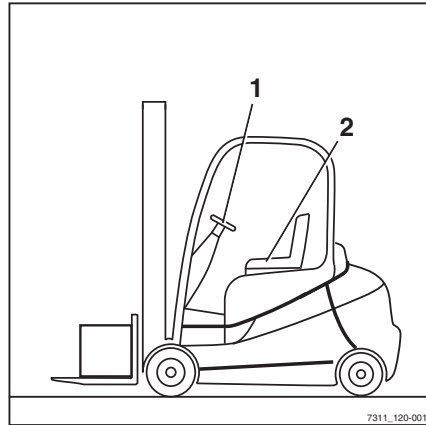

## Closing the bonnet

- Holding it by the handle, pull down the bonnet until the lock audibly engages.
- Adjust the seat (2); refer to ⇒ Chapter "Adjusting the MSG 65/MSG 75 driver's seat", P. 5-76. ▷
- Adjust the steering column (1).

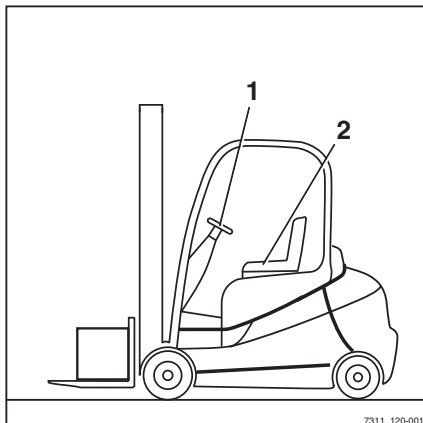

7311\_120-001

## Providing access to maintenance points

### Removing and attaching the left side cover

#### Removing the cover

- Release the quick release clamps (1) with a 1/4 revolution.
- Remove the cover (2) and put carefully aside.

#### Attaching the cover

- Carefully position the cover (2).
- Lock the quick release clamps (1) with a 1/4 turn.

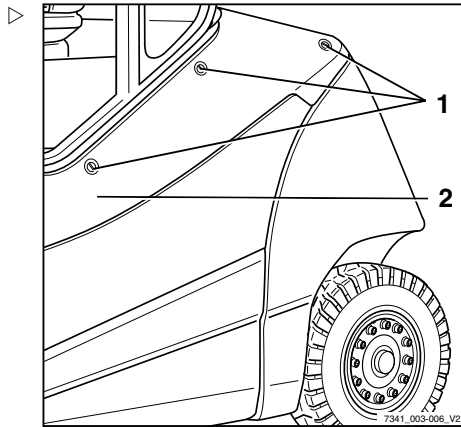

### Installing and removing the bottom plate

#### Removing the bottom plate.

#### **⚠ CAUTION**

Risk of short circuit if cables are damaged!

- Check the connecting cables for damage.
- When removing and reinstalling the bottom plate, make sure that the connecting cables are not damaged.

#### **i NOTE**

*The bottom plate has a recess that the operator can insert his fingers into to lift it. The recess is beneath the rubber mat.*

#### **i NOTE**

*The accelerator pedal is attached to the bottom plate and is removed with this also. The connecting plug for the accelerator is located underneath the bottom plate.*

- Remove the rubber mat.

## Providing access to maintenance points

- Grasp the recess (3) in the bottom plate (2). ▷
- Lift up the bottom plate.

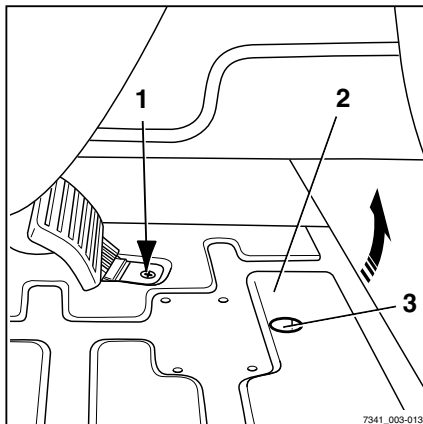

- Disconnect the plug connector (1) on the accelerator pedal. ▷
- Lift bottom plate and place in a safe location.

## Installing the bottom plate

**⚠ WARNING**

Risk of crushing between bottom plate and frame edge!

If limbs or objects are between the bottom plate and frame edge when the bottom plate is closed, they can be crushed.

- Make sure that when you close the bottom plate, there is nothing between the cover and the frame edge.
- 
- Position the bottom plate at the front.
  - Connect the connection assembly to the accelerator pedal.
  - Carefully guide the bottom plate down and close.
  - Insert the rubber mat.

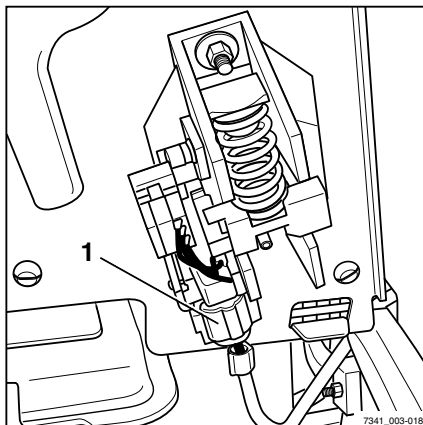

## Providing access to maintenance points

### Opening and closing the right-hand service flap

#### Opening the service flap

#### **⚠ WARNING**

Risk of injury from the service flap dropping!

The service flap (1) is equipped with gas springs that hold the service flap in opened position. In the case of additional load, for example, through heavy objects, strong wind or other persons, the service flap can drop suddenly. Through cold weather and ageing, the performance of the gas springs can also reduce and lead to the flap dropping.

- Make sure that the service flap is not being pushed down by strong winds or other persons.
  - If the gas springs no longer hold the service flap independently, notify the authorised service centre.
- 
- Unlock the quick release clamp (1) with a 1/4 turn in a clockwise direction.
  - Open the service flap lock (3) with the key.
  - To unlock, pull the handle (4) and at the same time use the other handle (2) to swivel the service flap upwards.

#### **i NOTE**

*Beneath the service flap there is a latch that engages in the upper position of the service flap and prevents accidental closing.*

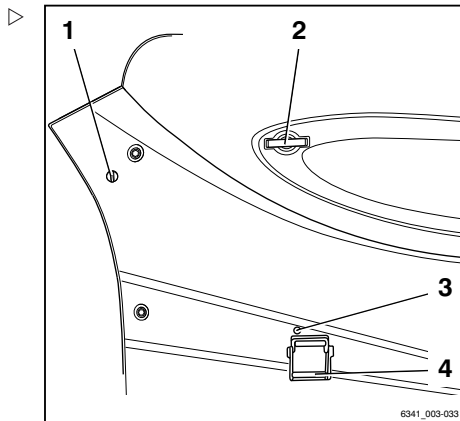
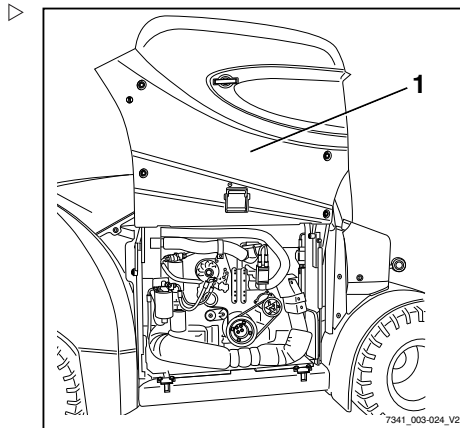



## Providing access to maintenance points

- Make sure that the safety hook (1) engages in the gap of the holder (2). ▷

**Closing the service flap****⚠ CAUTION**

Limbs can become trapped when closing the service flap — risk of crushing!

When you close the service flap, there must be nothing between the service flap and the edge of the frame.

- Do not grasp any edges. Always close the battery cover by grasping one of the handles in each hand.
- Carefully close the service flap.
- Only close the service flap if there are no parts of the body in the way.

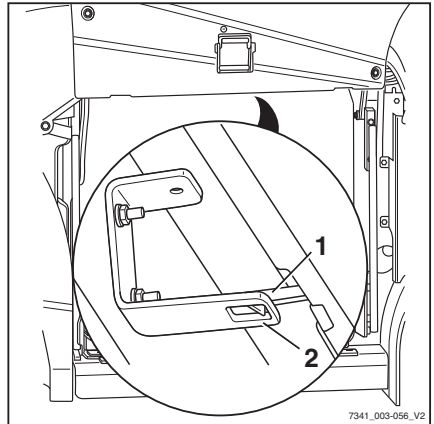

- To close the service flap, take hold of the handles (2) and (4) at the same time and pull down firmly. ▷
- Make sure that the service flap lock engages when you close it.
- Lock (3) the service flap using the key.
- Lock the quick release clamp (1) with a 1/4 turn in an anti-clockwise direction.

**i NOTE**

The service flap is only correctly locked if the top section of the handle (4) closes flush with the cover.

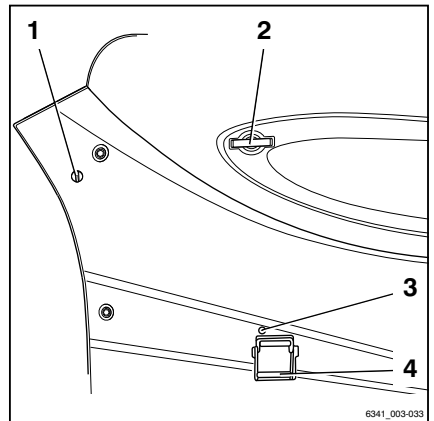

## Service work

## Service work

## Cleaning the radiator and checking for leaks

**⚠ WARNING**

Risk of burns due to hot components!

Components on the engine (e.g. engine block, radiator, etc.) can be so hot that direct contact can burn the skin and can burn or singe materials.

- Make sure that the engine and cooling system have cooled down.
- Do not grasp or touch hot components.
- In the event of burns, seek first aid immediately.
- If materials are burning, take fire-fighting measures immediately.

- Park the truck securely.
- Open the bonnet.
- Clean the radiator fins (1) on the radiator with a suitable brush and blow them out using compressed air (max. 2 bar).
- Check the radiator and coolant hoses for leaks and tighten the clips if necessary.

**⚠ CAUTION**

In the event of a leak, there is a risk of engine damage due to overheating!

A loss of cooling fluid from leaking coolant hoses or from the radiator reduces the cooling capacity. The engine may become excessively hot and severely damaged.

- Tighten clips at leaking hose connections.
- Check whether the leakage has been eliminated. If not, notify the authorised service centre.

- Close the bonnet.

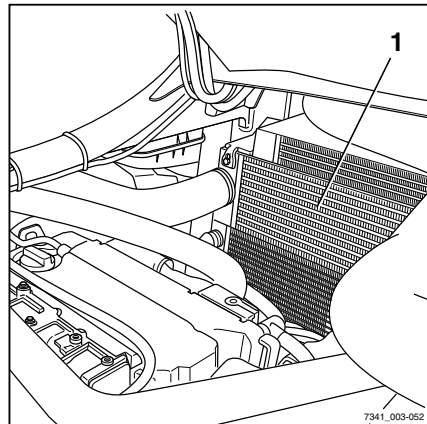

- Perform a visual inspection of the radiator from the rear of the truck. ▷
- If necessary, unscrew the screw joints (2) for the radiator grille and dismantle it to clean the radiator behind.
- Clean the radiator grille (1).
- If necessary, re-attach the radiator grille and screw tight.

**i NOTE**

*Make sure that the radiator grille is tightly screwed on.*

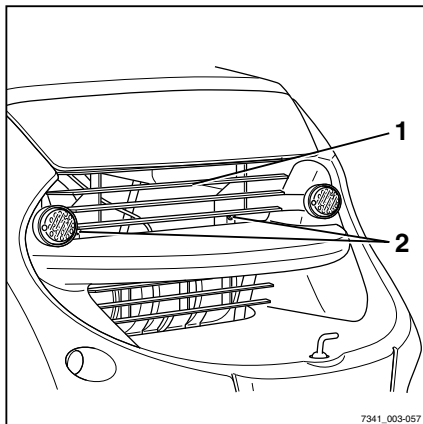

7341\_003-057

## Topping up the cooling fluid and checking the coolant concentration

**⚠ WARNING**

Risk of scalding due to hot cooling fluid!

The cooling system is pressurised! When opening the cooling fluid expansion reservoir (2), coolant can escape if the engine is hot. Always switch the engine off and let it cool down before opening the coolant reservoir.

- Switch off engine and let it cool down.
- Do not open the radiator filler cap (1) until the engine has cooled down.

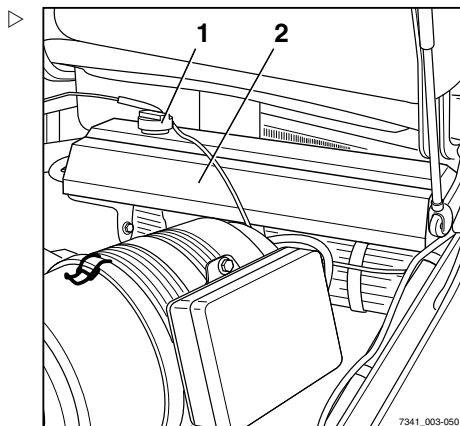

7341\_003-050

**⚠ WARNING**

Cooling fluid and coolant are hazardous to health!

- Observe the safety regulations for handling coolant.

**⚠ CAUTION**

Risk of engine damage!

If the cooling fluid level is low, this indicates a leak in the cooling system.

- Check the cooling system for leaks; refer to the section entitled "Cleaning the radiator and checking for leaks".

- Open the bonnet.

## Service work

- Open the radiator cap (1) slowly and release excess pressure.
- Turn further and remove the radiator filler cap.
- Check the concentration of the coolant.

### Concentration of the coolant

#### **▲ CAUTION**

Risk of corrosion!

The percentage of coolant must always be at least 40%, even if frost protection is not needed in warmer climates.

If an increased level of frost protection is required for climatic reasons, the percentage of coolant can be increased to up to 60%.

The percentage of coolant must not exceed 60%, otherwise the frost protection is reduced. In addition, the cooling effect is also reduced.

- Only use clean, softened water for the water percentage.

Frost protection up to °C	Water percentage %	Coolant percentage %
-25	60	40
-30	55	45
-35	50	50
-40	40	60

For details of the filling quantity in the cooling system, see the section entitled "Maintenance data table".

#### **▲ CAUTION**

Coolant with a different specification must not be mixed in!

- Only use the coolant specified in the maintenance data table to top up the cooling system.
- Only use coolant according to the manufacturer's instructions.

- Screw the radiator filler cap (1) back on tightly.
- Close the bonnet.

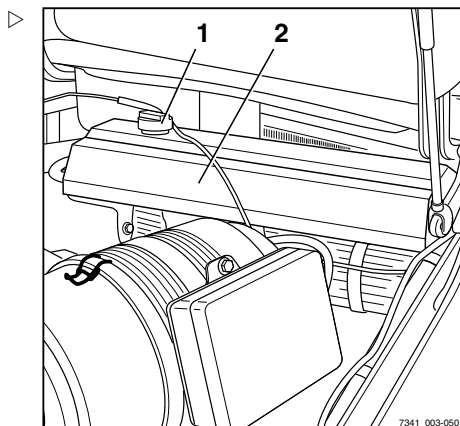

### Draining water from the fuel filter



#### ⚠ WARNING

Diesel fuel is flammable, toxic and damages the environment! Contact with diesel fuel can cause skin irritation and spilled diesel fuel can cause slipping.

- Observe safety regulations regarding handling diesel fuel, see the "Safety regulations for handling consumables" chapter.

- Open the service flap (1) on the right.

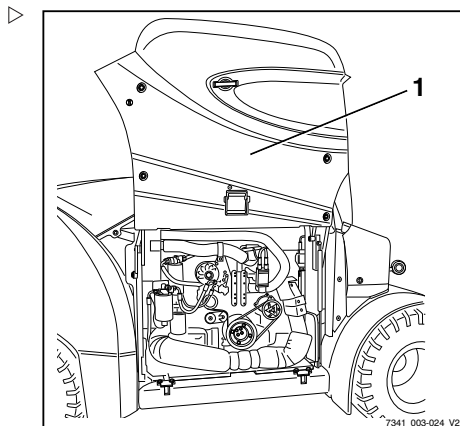

## Service work

- Cover the area beneath the fuel filter (1) carefully with a cleaning cloth.

**▲ CAUTION**

Risk of fire!

The heat protection sleeve (5) of the exhaust gas system must not be polluted with diesel fuel. If diesel fuel penetrates the material of the heat protection sleeve, this can lead to the sleeve and surrounding components catching fire.

- Make sure that diesel fuel does not pollute the heat protection sleeve.

- Keep a suitable collection container beneath the outlet pipe (3).

**▲ CAUTION**

Component damage possible!

The fuel filter is equipped with a level indicator that reports water aggregation in the fuel filter on the display and operating unit. The sensor cable (4) is embedded with the screw plug (2). Do not loosen the screw plug more than one revolution; otherwise the sensor cable may be damaged.

- Carefully undo the screw plug.
- Undo the screw plug (2) on the fuel filter and drain fluid until clean diesel fuel emerges.
- Tighten the screw plug again by hand.
- Remove the cleaning cloth from the heat protection sleeve.
- Close the service flap on the right.

**i NOTE**

*Draining is particularly necessary in tropical climates and dependent on the fuel quality used.*

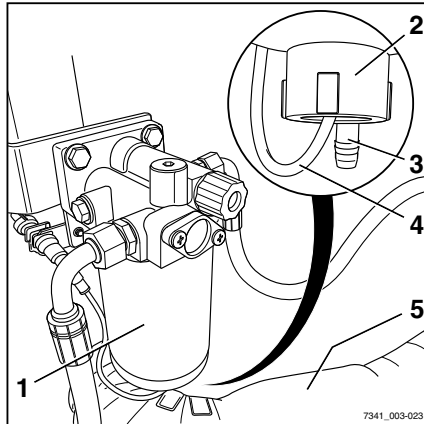

### Cleaning the pre-cleaner

- Loosen clamp (1) on pre-cleaner.
- Remove housing cover (2).
- Remove and empty dust container (3).
- Clean coarse contamination from lower part of container (4).
- Re-attach dust container and secure with clamp.

#### NOTE

*Do not fill pre-cleaner with oil. Replace damaged container parts.*

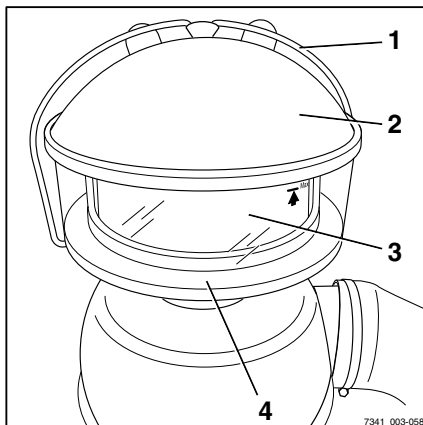

### Cleaning the oil tank on the oil bath air filter

#### WARNING

There is a risk of slipping on spilled oil, particularly when combined with water!

The oil tank (4) is filled with oil.

- Carefully remove the oil tank.
  - Collect spilt oil immediately using an oil binding agent and dispose of in an environmentally friendly way.
  - Observe the safety information for handling oils, see the "Oils" chapter.
- 
- Release the four clamps (2) on the oil tank and carefully remove the oil tank (1).
  - Empty the oil tank and clean using degreasing cleaning material.

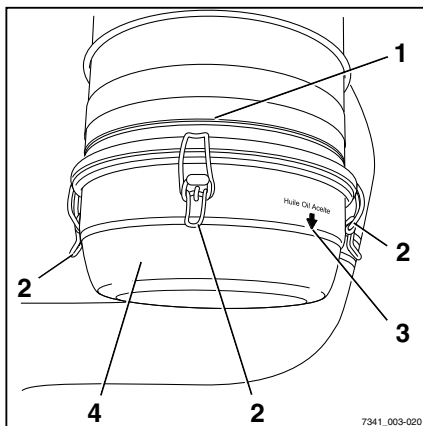

#### ENVIRONMENT NOTE

*Oils are water pollutants!*

- *Dispose of contaminated oil, oil sludge and used cleaning material in an environmentally friendly way.*
- Fill the oil tank (4) to the level mark (3) with engine oil.

For engine oil specifications, see the chapter entitled "Maintenance data table".

## Service work

- Carefully install the oil tank and engage the four clamps (2) on the housing (1).

## Replacing the air filter cartridges

 NOTE

*The air filter cartridges must be changed if the AIR FILTER message appears on the display and operating unit, or at least every 3000 hours or every two years.*

- Open the bonnet; see the chapter entitled "Opening the bonnet".

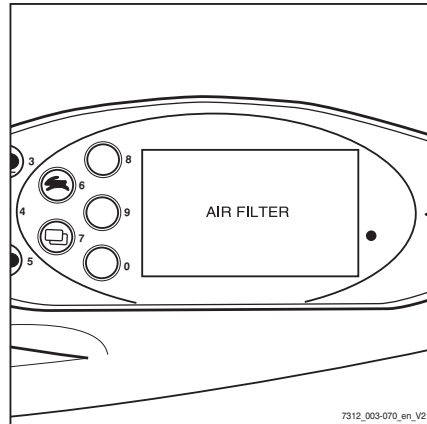

7312\_003-070\_en\_V2

- Release the three clamps (1) on the air filter and remove the air filter cover (2).

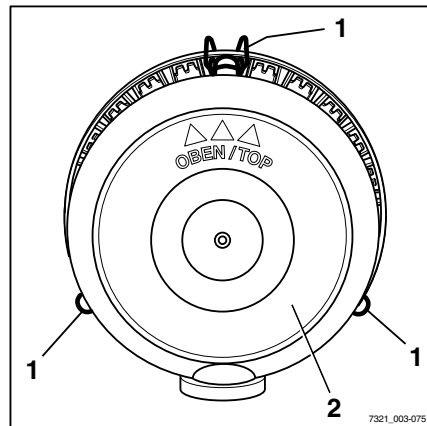

7321\_003-075



- Remove the filter cartridge (3).

**⚠ CAUTION**

Risk of engine damage!

The safety cartridge must remain in the air filter housing until all residual dirt has been removed from the housing so that no dirt enters the intake system!

- Wipe out the air filter housing using a damp cloth.

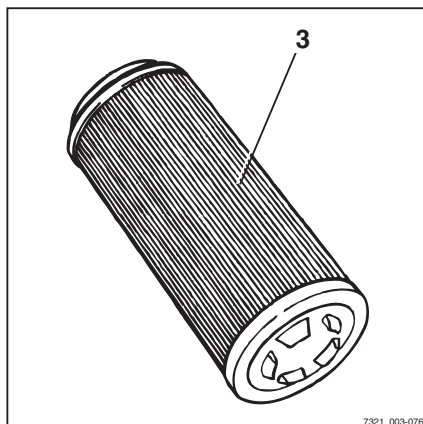

- Remove the safety cartridge (4), check for contamination, and change it if necessary.
- Refit the safety cartridge.
- Insert a new filter cartridge (3).

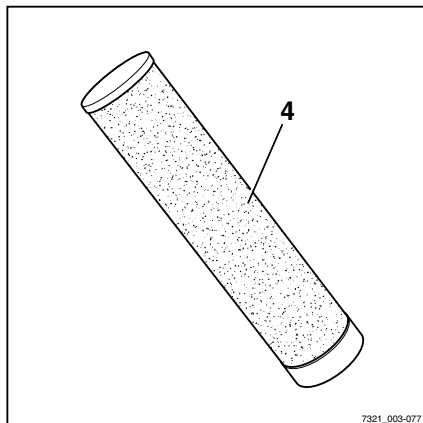

### Service work

- Refit the air filter cover (5) with the mark (6) facing upwards
- Engage the clamps (7) on the air filter.
- Close the bonnet.

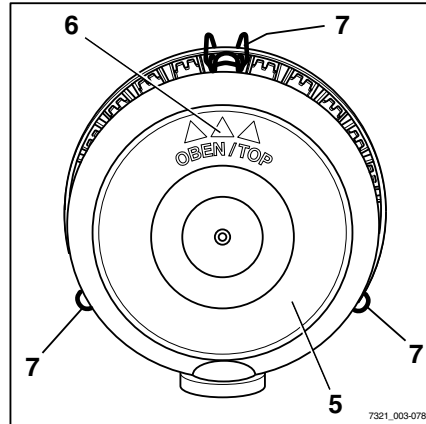

### Lubricating the joints and controls

- Oil or grease other bearing points and joints according to the maintenance data table; see ⇒ Chapter "Maintenance data table", P. 6-313.
- Driver's seat guide
- Lubricate bonnet hinges at the lubricating nipple
- Control linkage for valves
- In the cab, lubricate door hinges at the lubricating nipple (variant)
- Lubricate shafts and joints in dual-pedal operation (variant)

### Checking the door latch

- Inspect the condition of the catch bolt and check for wear.
- Check the lock mechanism for easy operation.

## Maintaining the seat belt

### **⚠ DANGER**

**There is a risk to life if the seat belt fails during an accident!**

If the seat belt is faulty, it may tear or open during an accident and no longer keep the driver in the driver's seat. The driver may therefore be hurled against the truck components or out of the truck.

- Ensure operational reliability by continually testing.
- Do not use a truck with a defective seat belt.
- Only have a defective belt replaced by your service centre.
- Only use genuine spare parts.
- Do not make any changes to the belt.

### **i NOTE**

*Carry out the following checks on a regular basis (monthly). In the case of significant strain, a daily check is necessary.*

### Checking the seat belt

- Pull out the belt (3) completely and check for wear. ▷

The belt must not be frayed or cut. The stitching must not be loose.

- Check whether the belt is dirty.
- Check whether parts are worn or damaged, including the attachment points.
- Check the buckle (1) to ensure that it locks in properly.

When the belt tongue (2) is inserted, the belt must be held securely.

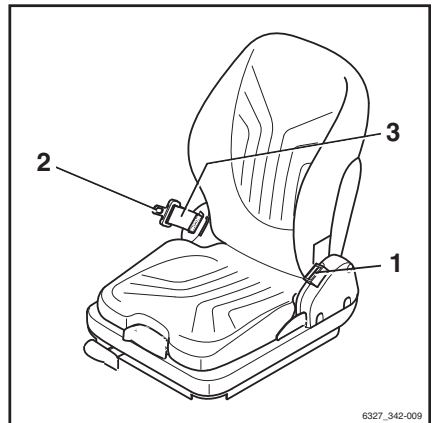

## Service work

- The belt tongue (2) must release when the red button (4) is pressed. ▷
- The automatic blocking mechanism must be tested at least once a year:
- Park the forklift truck on level ground.
- Pull out the belt with a jerk.

The automatic blocking mechanism must block extension of the belt.

- Tilt the seat at least 30 ° (if necessary, remove the seat).
- Slowly extend the belt.

The automatic blocking mechanism must block extension of the belt.

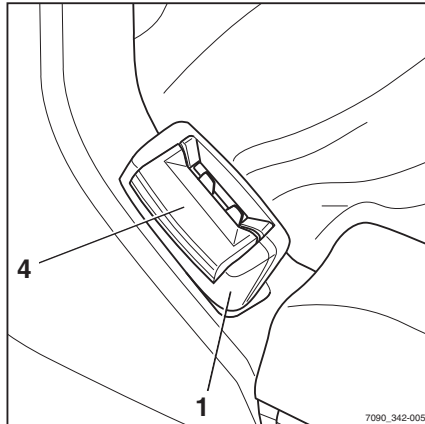

## Cleaning the seat belt

- Clean the seat belt as necessary, but without using chemical cleaning materials (a brush will suffice).

## Replacement after an accident

As a rule, the seat belt must be changed after an accident.

## Checking the driver's seat

### ▲ WARNING

Risk of injury!

- After an accident, check the driver's seat with attached restraining belt and fastening.
- 
- Check the controls for correct operation.
  - Check the condition of the seat (e.g. wear on the upholstery) and secure fastening to the hood.

### ▲ WARNING

Risk of injury!

- Have the seat repaired by the service centre if you identify any damage during the checks.

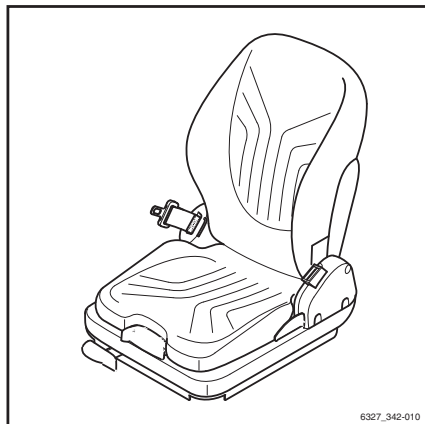

## Changing the heating system fresh air filter

The fresh air filter for the heating system is on the right on the exterior of the cab.

- Loosen the quick-release clamp (1) by turning it and remove the cover (2).

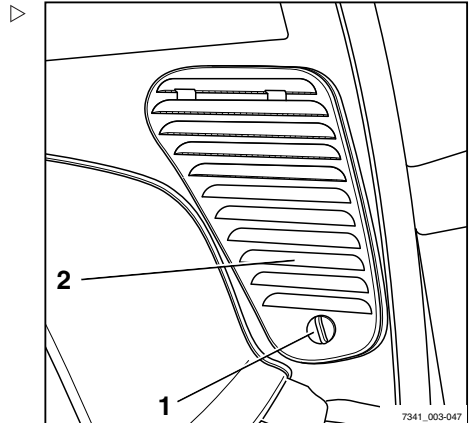

- Grasp the filter insert (3) at the finger opening (4) and remove it completely from the filter housing.
- Check the filter insert for contamination and beat out.

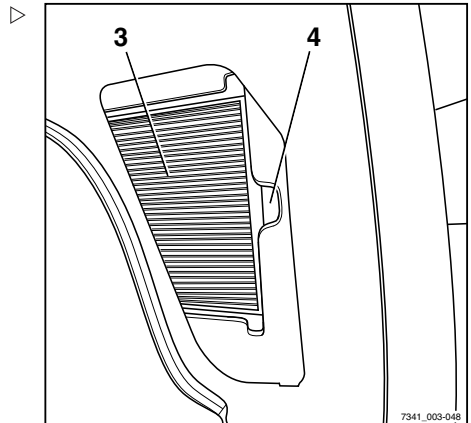

### NOTE

*Replace the filter insert when it is clearly grey, but at least every two months.*

- Remove pollution present in the filter housing and fresh-air inlet.
- Insert the filter insert back into the filter housing.
- Ensure that the filter insert sits correctly and precisely in the filter housing.
- Attach the cover and lock the quick-release clamp.

## Service work

## Replacing the recirculated air filter for the heating system

The recirculated air filter for the heating system is located on the right-hand side of the cab, underneath the heating system panelling (1).

- Unscrew the screws (2) and remove the heating system panelling.
- Completely remove the filter mat (3) from the filter housing.
- Check the filter mat for contamination and beat out.

### NOTE

*Replace the filter mat when it is clearly grey, but at least every two months.*

- Remove any dirt that has collected in the filter housing and recirculated-air inlet.
- Re-insert the filter mat into the filter housing.
- Make sure that the filter mat sits correctly and accurately in the filter housing.
- Attach the heating system panelling and secure tightly in place using the screws.

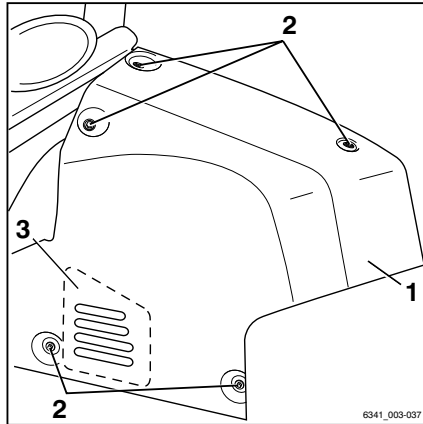

## Greasing the automatic tow coupling

### NOTE

*Wear to moving parts can be significantly reduced by appropriate servicing and regular lubrication of the coupling.*

- Avoid over-greasing!

### NOTE

*Close the coupling before cleaning with a high-pressure cleaner. After cleaning, lubricate the coupling pin, tow bar eye and its supporting surface again.*

**Model RO\*243**

- Pull out the safety handle (3).
- Push the hand lever (2) upwards.
- Grease using the lubricating nipple(1) in accordance with the maintenance data table; see → Chapter "Maintenance data table", P. 6-313.
- Close the coupling by raising the coupling pin with a suitable tool.
- For journeys with a rigid drawbar trailer, lubricate the underside of the tow bar eye and the supporting surface on the coupling.

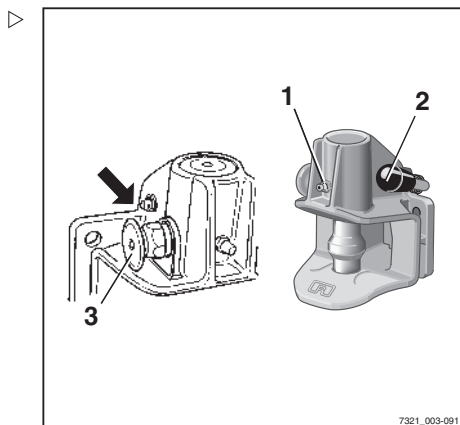

- Determine the wear on the coupling pin.
- The diameter of the spherical part must not be less than 36.5 mm.

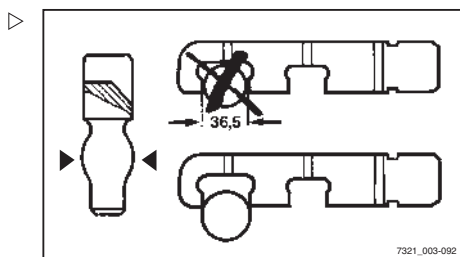
**Model RO\*244 A**

- Open coupling.
- Grease using the lubricating nipple(1) in accordance with the maintenance data table; see → Chapter "Maintenance data table", P. 6-313.
- Grease coupling pin, tow bar eye and its supporting surface.

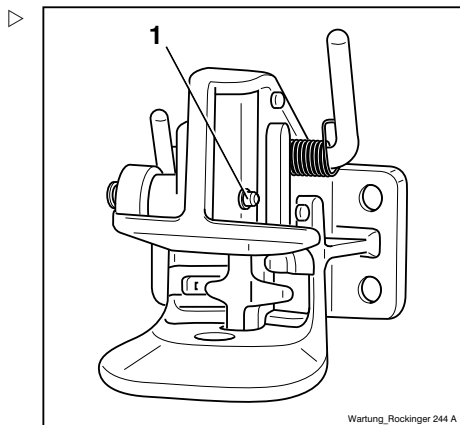

## Service work

**Model RO\*245**

- Lubricate via the points provided for this purpose (lubricating nipple, opened coupling) in accordance with the maintenance data table; see ⇒ Chapter "Maintenance data table", P. 6-313.
- Grease the supporting surface for the tow-bar eye.

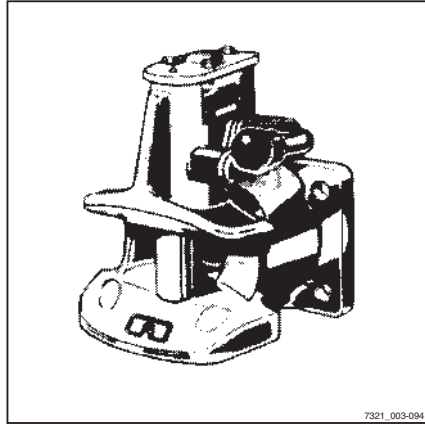
**Model RO\*841**

- Lubricate via the points provided for this purpose (lubricating nipple, opened coupling) in accordance with the maintenance data table; see ⇒ Chapter "Maintenance data table", P. 6-313.
- Grease the supporting surface for the tow-bar eye.

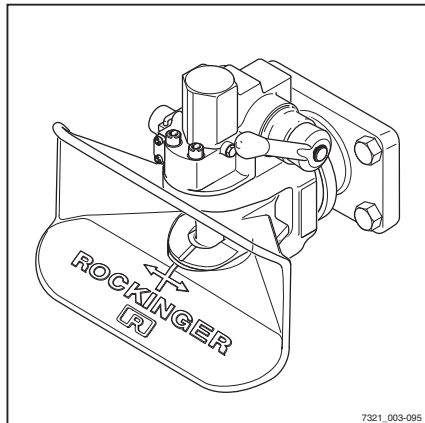



## Servicing wheels and tyres

### ⚠ WARNING

Risk of accident!

Uneven wear reduces the stability of the truck and increases the braking distance.

- Worn or damaged tyres (left or right) must be replaced immediately.

### ⚠ WARNING

Risk of tipping!

Tyre quality affects the stability of the truck.

If you wish to use a different type of tyre on the truck from the tyres approved by the truck manufacturer, or tyres from a different manufacturer, you must first obtain approval from the truck manufacturer.

### ⚠ WARNING

Risk to stability!

When using pneumatic tyres or solid rubber tyres, rim wheel parts must never be changed and rim wheel parts from different manufacturers must not be mixed.

## Checking air pressure

- Check the air pressure of all four tyres; adjust if necessary.

### **i** NOTE

*The correct air pressure for pneumatic tyres (variant) is determined by the type of tyres used. Observe the information on the adhesive labels (2) on the truck.*

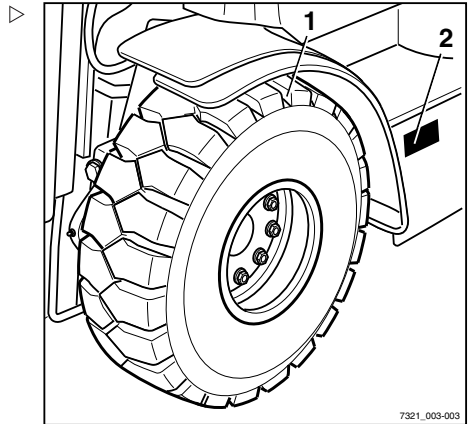

## Service work

## Checking condition and wear of the tyres ▷

**⚠ WARNING**

Tyre quality affects the stability and handling of the truck.

Changes can only be made in consultation with the manufacturer.

When changing wheels or tyres, always ensure that this does not cause the truck to tilt to one side (e.g. always change right and left wheels at the same time).

**i NOTE**

*The wear of the tyres on an axle must be approximately the same.*

- *The tread depth (1) for pneumatic tyres must be **at least 1.6 mm** at every point on the tread.*
  - *Super-elastic tyres (variant) can be worn down to the wear mark (3).*
- Check the tread depth on all four tyres.
  - Check distance between the tyre tread and the wear mark.
  - Remove any foreign bodies imbedded in the tyre tread.

## Checking wheel fastenings

- Check that the wheel fastening (4) is securely fastened and retighten as necessary.
- Observe the torques; see the "maintenance data table" ▷

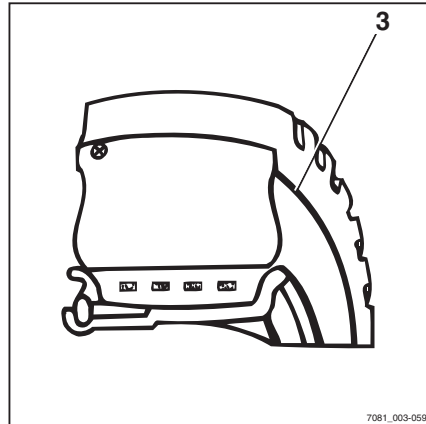

7081\_003-059

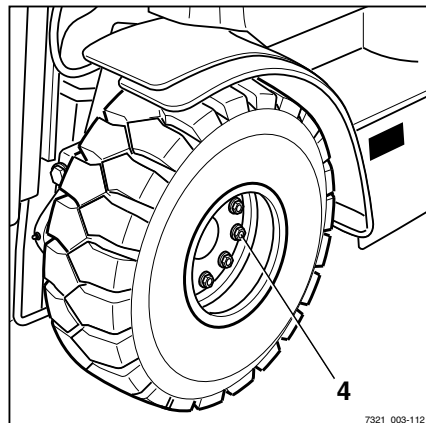

7321\_003-112

## Replacing the fuses

- Open the bonnet.

### **⚠ DANGER**

**Risk of fire! Using the wrong fuses can result in short circuits.**

- Use only fuses with the prescribed nominal current, see the "Fuse assignment" chapter.
- 
- Open the cover fastenings (1) and remove the cover.
  - Change the defective fuse.
  - Close the bonnet.

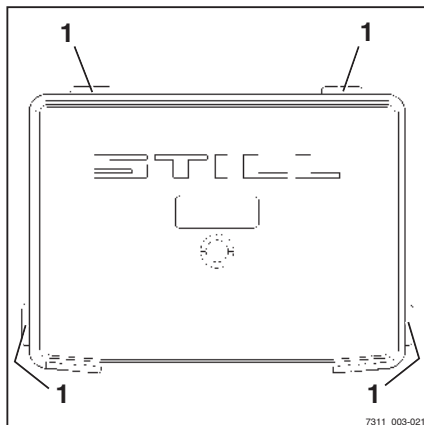

7311\_003-021

## Checking the hydraulic oil level

### **⚠ CAUTION**

Hydraulic oils are hazardous to your health and are under pressure during operation.

- Note the safety regulations in the "Hydraulic fluid" chapter.
- 
- Park the truck securely.
  - Remove the left side cover.

## Service work

- Unscrew breather filter (1).

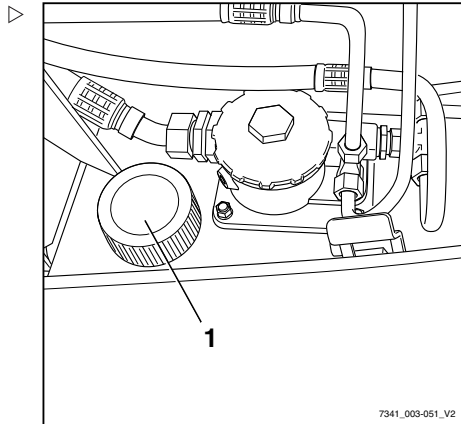

- Check the oil level on the oil dipstick. The oil level must be at least up to the mark (2) on the dipstick. ▷
- If the oil level is too low, pour hydraulic oil of the corresponding specification according to the maintenance data table into the filler neck.
- Pour hydraulic oil up to the upper end of the marking (2) on the oil dipstick (maximum).

**NOTE**

*Use a funnel.*

**ENVIRONMENT NOTE**

*Carefully collect any spilled oil and dispose of it in an environmentally friendly manner.*

- Screw in the breather filter with oil dipstick.
- Attach the left side cover.

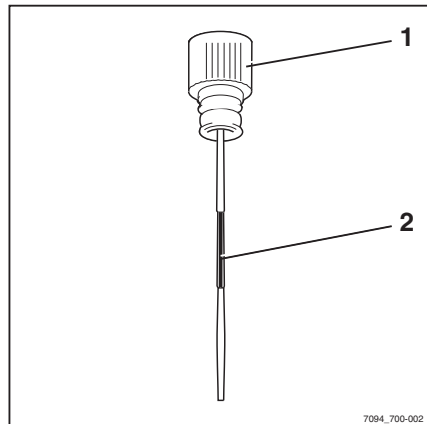

## Checking the hydraulic system for leaks



### ⚠ WARNING

Hydraulic oil under pressure can escape from leaking lines and cause injuries to the skin.

Wear suitable protective gloves, industrial goggles etc.

### ⚠ WARNING

Hydraulic hoses become brittle!

Hydraulic hoses should not be used longer than 6 years.

The specifications of BGR 237 should be complied with. Deviating national laws are to be taken into account.

- Check pipe and hose connection screw joints for leaks (traces of oil).

Hose lines must be changed if:

- The outer layer has been breached or becomes brittle with tears
- They are leaking
- There are unnatural deformations (e.g. bubble formation or buckling)
- A fitting is detached from the hose
- A fitting is badly damaged or corroded

Pipes must be changed if:

- There is abrasion with the loss of material
- There are unnatural deformations and detectable bending stress
- They are leaking

## Service work

**Lubricating the lift mast and roller track** ▷

- Remove dirt and lubricant residue from the roller track.
- Lubricate the roller tracks (1) of the outside, middle, and inside mast with a super-pressure adhesion lubricant to reduce wear. See ⇒ Chapter "Maintenance data table", P. 6-313.

** NOTE**

*Spray the roller track evenly from a distance of approx. 15-20 cm. Wait approx. 15 minutes until the equipment is ready to use again.*

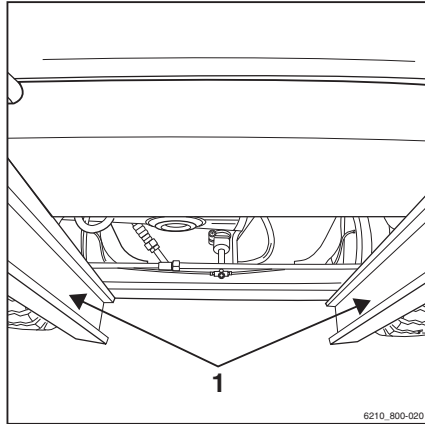

7

---

1000-hour maintenance/annual maintenance

## Other tasks

## Other tasks

- Perform all maintenance work; see the "Maintenance" chapter.

## Checking the exhaust gas system

- Inspect the exhaust gas system for external damage, secure fit, and leaks.

## Checking the lift cylinders and connections for leaks

**⚠ WARNING**

Risk of injury!

Observe safety regulations for working on the lift mast, see the "Working at the front of the truck" chapter.

- Check hydraulic connections and lift cylinders for leaks (visual inspection).
- Have leaking screw joints or leaking hydraulic cylinders repaired by the authorised service centre.

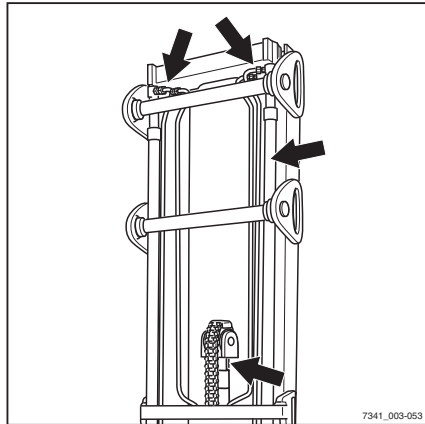

## Checking the fork arms

- Check the fork arms (1) for visible deformation and excessive wear.

Wear must not amount to more than 10% of the original thickness.

- Check the fork latch (3) for correct operation.
- Check that the locking screw (2) is secured and cannot fall out of the fork arms.
- Replace any worn or deformed fork arms.

**⚠ CAUTION**

Fork arms must not be uneven!

- Always replace both fork arms.

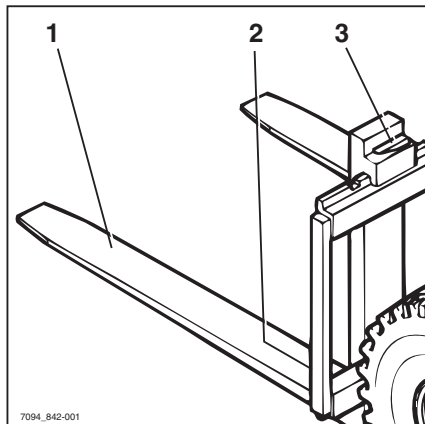



## Checking the reversible fork arms

### NOTE

*This check is only required for reversible fork arms (variant).*

- Check the outside of the fork bend (1) for cracks. Contact your service centre.

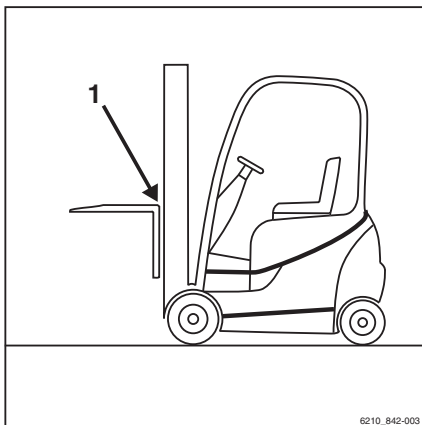

## Checking the reversible fork arms

## Technical data

## Dimensions

## Dimensions

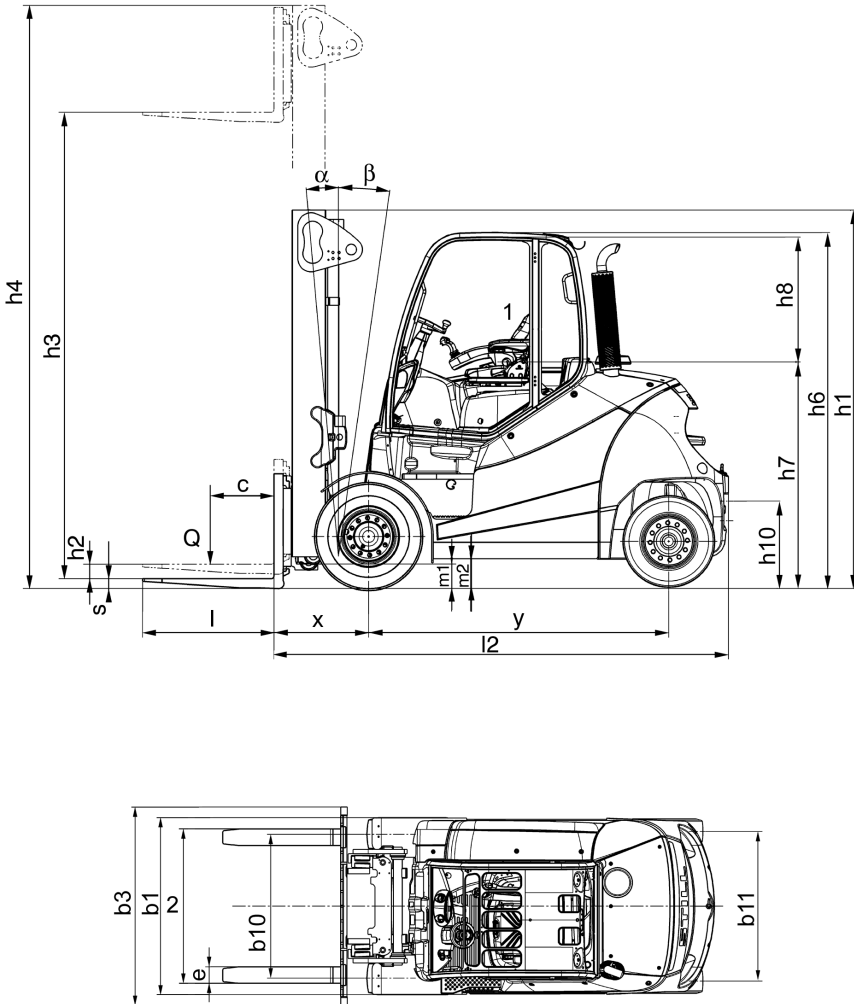

7341\_003-064

1 Seat is adjustable  $\pm 90$  mm

2 Fork spacing is adjustable

**i** NOTE

Measurements  $h_1$ ,  $h_3$ ,  $h_4$ ,  $h_6$  and  $b_1$  are customer-specific and can be taken from the order confirmation.

**Centre of gravity "S" (distance measured from the front axle)**

RX70-60	1036 mm
RX70-70	1036 mm
RX70-80	1036 mm
RX70-80 (LSP 900)	1036 mm

**i** NOTE

The specified centre of gravity "S" relates to trucks with standard equipment. If, for example, the truck is equipped with a different lift mast, attachment or driver protection structure, this value is only a guide value. If necessary, the centre of gravity "S" must be determined individually for each truck.

## VDI datasheet

**i** NOTE

These values apply to the standard device. Values for variants may deviate from this data.

### Key data

		RX70-60	RX70-70	RX70-80	RX70-80 LSP 900
Manufacturer		STILL GmbH	STILL GmbH	STILL GmbH	STILL GmbH
Drive: electric, diesel, petrol, LPG, mains electric		Diesel	Diesel	Diesel	Diesel
Operation: manual, accompanied, standing, seated, order picker		Seated	Seated	Seated	Seated
Rated capacity/load	Q (kg)	6000	7000	8000	8000
Load centre of gravity distance	c (mm)	600	600	600	900

## VDI datasheet

		RX70-60	RX70-70	RX70-80	RX70-80 LSP 900
Load distance	x (mm)	710	720	720	750
Wheelbase	y (mm)	2285	2285	2405	2480

## Weights

		RX70-60	RX70-70	RX70-80	RX70-80 LSP 900
Net weight	kg	10477	11370	12274	14690
Axle load with front load	kg	14854	16599	18396	20535
Axle load with rear load	kg	1623	1771	1878	2155
Axle load without front load	kg	5415	5555	6006	7213
Axle load without rear load	kg	5062	5815	6268	7477

## Wheels, chassis frame

		RX70-60	RX70-70	RX70-80	RX70-80 LSP 900
Tyres: superelastic (SE), solid rubber (V), pneumatic (L)		SE	SE	SE	SE
Front wheel size		355/65-15	8.25-15	8.25-15	315/70-15
Rear wheel size		28x9-15	250-15	250-15	28x12.5-15
Number of front wheels (x = driven)		2x	4x	4x	4x
Number of rear wheels (x = driven)		2	2	2	2
Front track width, single tyre	b 10 (mm)	1306	1510	1510	1561
Rear track width	b 11 (mm)	1358	1358	1358	1432

## Basic dimensions

		RX70-60	RX70-70	RX70-80	RX70-80 LSP 900
Tilt of lift mast/fork carriage, forwards	De-grees	5	5	5	5
Tilt of lift mast/fork carriage, backwards	De-grees	8	8	8	8

		RX70-60	RX70-70	RX70-80	RX70-80 LSP 900
Height with lift mast retracted	h1 (mm)	2710	2710	2710	2710
Free lift	h2 (mm)	150	150	150	150
Lift height	h3 (mm)	3500	3150	3150	2750
Height with lift mast extended	h4 (mm)	4440	4240	4240	4140
Height above overhead guard	h6 (mm)	2697	2697	2697	2697
Seat height in relation to SIP/standing height	h7 (mm)	1719	1719	1719	1719
Coupling height	h10 (mm)	510/660	510/660	510/660	510/660
Overall length	l1 (mm)	4640	4732	4800	5520
Length including fork back	l2 (mm)	3440	3532	3600	3720
Overall width	b1	1597	1998	1998	2140
Fork arm thickness	s (mm)	70	70	70	70
Fork arm width	e (mm)	150	150	150	150
Fork arm length	l (mm)	1200	1200	1200	1800
Fork carriage DIN 15173, class/form A, B		Class IV, form A	Class IV, form A	Class IV, form A	Class IV, form A
Fork carriage width	b3 (mm)	1600	1800	1800	2180
Ground clearance with load under lift mast	m1 (mm)	220	220	220	220
Ground clearance at the centre of the wheelbase	m2 (mm)	210	210	210	210
Aisle width for pallets 1000 x 1200 crosswise	Ast (mm)	4907	4987	5056	5185
Aisle width for pallets 800 x 1200 lengthwise	Ast (mm)	5107	5187	5256	5385
Turning radius	Wa (mm)	3007	3067	3136	3235
Smallest pivot point distance	b13 (mm)	877	877	894	900

## VDI datasheet

## Performance data

		RX70-60	RX70-70	RX70-80	RX70-80 LSP 900
Driving speed with load	km/h	20	20	20	20
Driving speed without load	km/h	20	20	20	20
Lifting speed with load	m/s	0.51	0.42	0.42	0.41
Lifting speed without load	m/s	0.51	0.42	0.42	0.43
Lowering speed with load	m/s	0.56	0.50	0.50	0.50
Lowering speed without load	m/s	0.52	0.42	0.42	0.42
Pulling force with load	N	51090	46370	46300	43400
Pulling force without load	N	31680	32540	35460	36750
Climbing capability with load	%	33	27	24	21
Climbing capability without load	%	32	30	30	29
Acceleration time with load	s	5.4	5.5	5.6	5.7
Acceleration time without load	s	4.9	5.0	5.1	5.1
Service brake		Mech./hydr.	Mech./hydr.	Mech./hydr.	Mech./hydr.

## Engine

		RX70-60	RX70-70	RX70-80	RX70-80 LSP 900
Engine manufacturer/model		Deutz/ TCD 4.11	Deutz/ TCD 4.11	Deutz/ TCD 4.11	Deutz/ TCD 4.11
Engine power rating in accordance with ISO 1585	kW	80	80	80	80
Nominal speed	rpm	2400	2400	2400	2400
Number of cylinders		4	4	4	4
Displacement	cm <sup>3</sup>	4038	4038	4038	4038
Fuel consumption in accordance with the VDI cycle	l/h	7.0	7.8	8.6	9.2
On-board power supply	V	12	12	12	12



Other

		<b>RX70-60</b>	<b>RX70-70</b>	<b>RX70-80</b>	<b>RX70-80 LSP 900</b>
Version of drive unit		Diesel- electric	Diesel- electric	Diesel- electric	Diesel- electric
Working pressure for attachments	bar	260	260	260	260
Oil flow for attachments	l/min	60	60	60	60
Capacity of fuel tank	l	110	110	110	110
AdBlue tank capacity	l	10	10	10	10
Sound pressure level $L_{pAZ}$ <sup>1)</sup>	dB (A)	75	75	75	75
Sound power level $L_{wAZ}$	dB (A)	97	97	97	97
Human vibration acceleration <sup>2)</sup> according to EN 13059	m/s <sup>2</sup>	0.31	0.31	0.31	0.31
Tow coupling, type/model		Bolt	Bolt	Bolt	Bolt

<sup>1)</sup> With cab. Without a cab, the sound pressure level is increased

<sup>2)</sup> With standard driver's seat

## Ergonomic dimensions

## Ergonomic dimensions

**⚠ WARNING**

Danger of impact injuries to the head!

If the head of the operator is located too close to the underside of the roof, the suspension of the driver's seat or an accident may cause the head to strike the overhead guard.

To avoid head injuries, a minimum distance of **40 mm** must be ensured between the underside of the roof and the head of the tallest operator.

To determine the actual head clearance, the operator must sit in the driver's seat and the seat suspension must be set to this driver's requirements.

Due to the individual nature of height and body weight as well as the wide variety of types of driver's seat and overhead guard, the minimum head clearance must be ensured in every truck.

The driver's compartment has been designed taking ergonomics in the workplace into account and in accordance with EN ISO 3411. In general, from the seat position, the operator has sufficient space to reach the operating devices safely, to operate the truck and to view the outline of the truck. Operators whose body size deviates from the specified dimensions on which EN ISO 3411 is based must be individually considered by the operating company.

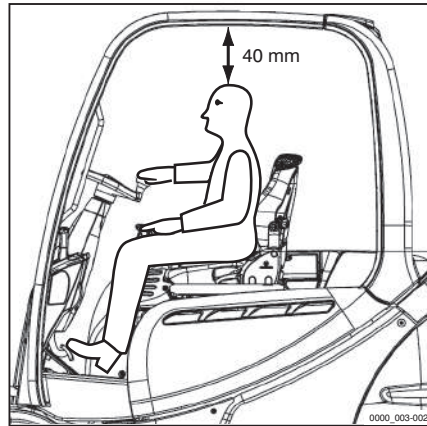



## Fuse assignment

## Fuse assignment

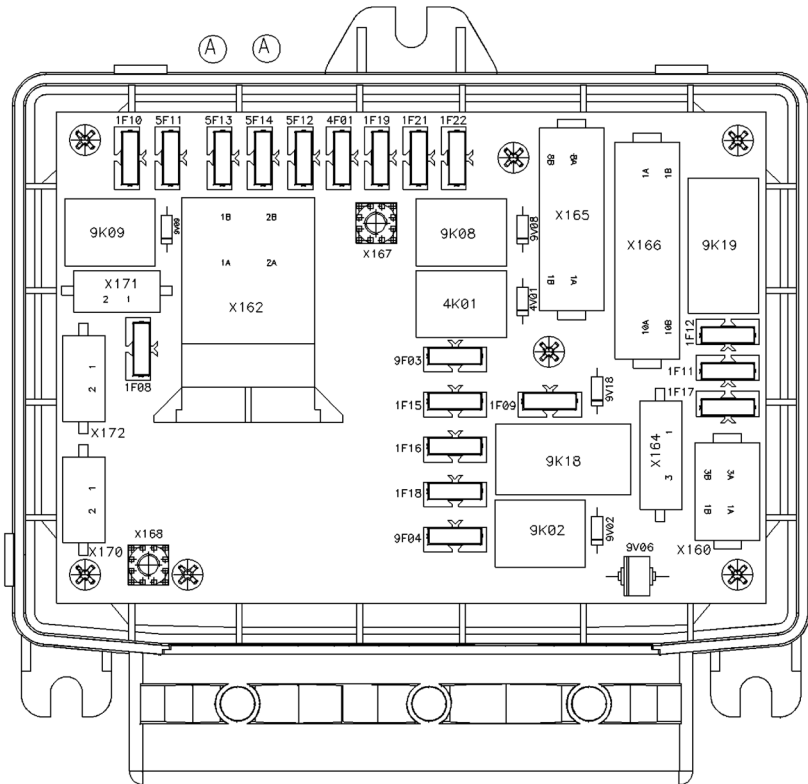

7311\_003-073

1F08	12 V battery (permanent positive), variants, 10 A	1F18	Converter for cooling fluid pump, axle-converter, 15 A
1F09	Switch lock, terminal 30, 10 A	1F19	12 V engine control unit (ECU), 10 A
1F10	Cooling fluid pump, 10 A	1F21	Burner air pump, preheating control unit, exhaust gas recirculation, 10 A
1F11	Converter, 10 A	1F22	Spark-ignition control unit, 15 A
1F12	Reserve, 15 A	4F01	Signal horn, 10 A
1F15	12 V for TCU, display and operating unit, 10 A	9F03	12 V for Option Board, 10 A
1F16	12 V for servo hydraulics, 10 A	9F04	Starter motor, terminal 50, 30 A
1F17	Time-delay relay, terminal 15, 10 A		

**Additional fuses**

In this truck, additional fuses are located on a fuse holder to the right of the fuse box.

** NOTE**

*Depending on the equipment, not all fuses will be present in the truck.*

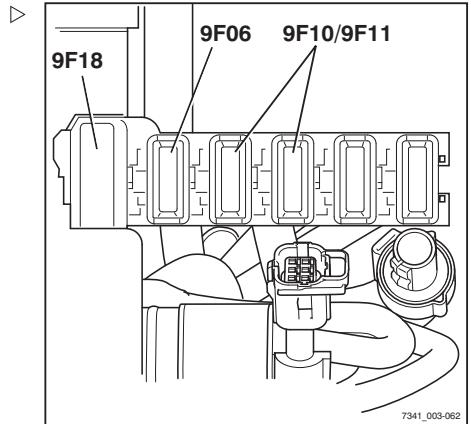

- 9F06 Sheathed-element heater plug, 25 A
- 9F10 Air conditioning (variant), 20 A
- 9F11 Air conditioning (variant), 20 A
- 9F18 Burner pump, 60 A

Fuse assignment

**A**

Access authorisation	
Changing the password	96
Defining the driver PIN	92
Entering the access code	91
Selecting the driver PIN	94
Access authorisation with PIN code	89
Accessories	5
Accident recorder	208
Actuating the drive direction switch	
Fingertip version	117
Joystick 4Plus version	117
Mini-console version	118
Mini-lever version	116
AdBlue	
Topping up	290
Address of manufacturer	I
Adjusting the armrest	79
Adjusting the fork	156
Adjusting the steering column	80
After washing	299

**Attachments**

Controlling using a double mini-lever	181
Controlling using the double mini-lever and the 5th function	183
Controlling via the joystick 4Plus	191
Controlling with a quadruple mini-lever	188
Controlling with a triple mini-lever	185
Controlling with the fingertip	193
Controlling with the fingertip and 5th function	194
Controlling with the quadruple mini-lever and the 5th function	190
Controlling with the triple mini-lever and the 5th function	187
Fitting	175
General controlling	179
Mounting	176
Releasing the pressure from the connections	177
Special risks	20
Taking up a load	200
Automatic lift cut out	129
Automatic tow coupling	223
Coupling RO*243	225
Coupling RO*244 A	227
Coupling RO*245	230
Uncoupling RO*243	227
Uncoupling RO*244 A	229
Uncoupling RO*245	231

**B****Battery**

Disposal	13
Battery acid	43
Before taking up load	151
Blue-Q	
Configure	240
Functional description	242
Switching off	243
Switching on	243

Bottom plate		
Installing	323	
Removing	322	
<b>C</b>		
Cab		
Operating the interior lighting	214	
Operating the rear window heating	215	
CE labelling	3	
Changes to the forklift truck	31	
Changing the drive direction	119	
Dual pedal version	122	
Changing the fork arms	144	
Changing the heating system fresh air filter	337	
Changing the password	96	
Checking for leaks	326	
Checking the coolant concentration	327	
Checking the cooling fluid level	74	
Checking the door latch	334	
Checking the driver's seat	336	
Checking the engine oil level	74	
Checking the exhaust gas system	348	
Checking the fork arms	348	
Checking the lift cylinders and connections for leaks	348	
Checking wheel fastenings	342	
Clamp locking mechanism		
Releasing	196	
Cleaning the dust valve	81	
Cleaning the electrical system	297	
Cleaning the radiator	326	
Cleaning the truck	295	
Cleaning the windows	298	
Climbing into the truck	83	
Climbing out of the truck	83	
Clipboard	219	
Closing the bonnet	321	
Closing the cab door	213	
Closing the side windows	214	
Condition of the roadways	113	
Consumables	41	
Coolant and cooling fluid safety information	46	
Disposal	46	
Safety information for diesel fuel	44	
Safety information for handling battery acid	43	
Safety information for handling oils	41	
Safety information for hydraulic fluid	42	
Contact details	I	
Coolant	327	
Coolant and cooling fluid	46	
Cooling fluid		
Topping up	327	
Copyright and trademark rights	7	
Coupling pin in the counterweight	221	
Coupling	221	
Uncoupling	223	
Crane loading	271	
Determining the loading weight	271	
Hooking on the lifting straps	272	
Cruise control	208	
Curve Speed Control	127	
<b>D</b>		
Damage	34	
Danger area	156	
Danger to employees	25	
Declaration of conformity	4	
Defects	34	
Defining the driver PIN	92	
Definition of directions	11	
Diesel engine emissions		
Checking	38	
Diesel fuel	44	
Filling up	287	
Non-road fuels	285	
Specifications	283	
Sulphur content	284	
Winter operation	285	
Dimensions	352	
Dimensions of roadways	112	



- Direction indicators ..... 203
    - Mini-console version ..... 204
    - Mini-lever version ..... 203
  - Disconnecting the battery ..... 283
  - Display and operating unit ..... 56
    - Additional indicators ..... 232
    - Adjusting the displays ..... 233
    - Configure Blue Q ..... 240
    - Standard display elements ..... 88, 232
  - Display messages
    - Display content ..... 245
    - Drive-specific ..... 258
    - General ..... 249
  - Display operating unit
    - Resetting the daily kilometres ..... 238
    - Setting the date ..... 238
    - Setting the language ..... 239
    - Setting the time ..... 238
  - Display symbols ..... 233
    - Auxiliary equipment soft key functions ..... 235
    - Error messages ..... 235
    - Menu navigation soft key functions ..... 236
    - Numeric keypad ..... 237
    - Operating messages ..... 234
    - Status LEDs ..... 236
    - Warning messages ..... 234
  - Disposal
    - Battery ..... 13
    - Components ..... 13
  - Documentation scope ..... 6
  - Double mini-lever ..... 58
    - Lifting/lowering the fork carriage ..... 138
    - Tilting the lift mast ..... 138
  - Driver rights, duties and rules of behaviour ..... 29
  - Driver's cab
    - Use ..... 102
  - Drivers ..... 29
  - Driving
    - on ascending and descending slopes ..... 165
  - Driving lights
    - Switching on and off ..... 201
  - Driving on gradients ..... 112
  - Driving on lifts ..... 165
  - Driving on loading bridges ..... 166
- ## E
- EC declaration of conformity in accordance with Machinery Directive ..... 4
  - Effects on additional consumers ..... 242
  - Emergencies
    - Truck tipping over ..... 277
    - Using the emergency hammer ..... 278
  - Emergency hammer ..... 278
  - Emergency lowering ..... 278
  - Emergency off
    - Checking for correct function ..... 106
    - Unlocking the switch ..... 86
  - Emergency shutdown ..... 276
  - Emissions ..... 48
    - Battery ..... 51
    - Exhaust gases ..... 50
    - Heat ..... 50
    - Noise emissions ..... 48
    - Vibrations ..... 49
  - Entering the access code ..... 91
  - Ergonomic dimensions ..... 358
  - Error code table ..... 246
  - Example ..... 152
- ## F
- Filling the washer system ..... 72
  - Fingertip ..... 62
    - Lifting/lowering the fork carriage ..... 143
    - Tilting the lift mast ..... 143
  - Fitting attachments ..... 175
  - FleetManager ..... 207
    - Accident recorder ..... 208
  - Fork arms
    - Length ..... 37
  - Fork extension ..... 146

- Four-way mini-lever . . . . . 60
- Fuel filter  
     Draining water from . . . . . 329
- Fuel hand pump . . . . . 288
- Fuse assignment . . . . . 360
- G**
- General . . . . . 2
- H**
- Handling gas springs and accumulators . . 36
- Hazard areas . . . . . 114
- Hazard warning system . . . . . 203
- Hazards and countermeasures . . . . . 22
- Heating system . . . . . 216  
     Adjusting the air flow . . . . . 218  
     Switching on . . . . . 217  
     Switching on the blower . . . . . 217
- Hydraulic blocking function . . . . . 136  
     Releasing . . . . . 136
- Hydraulic fluid . . . . . 42
- Hydraulic system  
     Checking for leaks . . . . . 345  
     Checking the oil level . . . . . 343
- I**
- Identification points  
     Overview . . . . . 64
- Impermissible use . . . . . 16
- Information for carrying out maintenance  
     Maintenance timeframe . . . . . 303
- Information symbols . . . . . 7
- Inserting wedges . . . . . 267
- Insulation testing . . . . . 40
- Insurance cover on company premises . . 31
- Interior lighting . . . . . 214
- Issue date of the operating instructions . . 7
- J**
- Jacking up . . . . . 318
- Joystick 4Plus . . . . . 61  
     Fork-carriage sideshift . . . . . 142  
     Lifting/lowering the fork carriage . . . 141  
     Tilting the lift mast . . . . . 141
- Jump-starting . . . . . 274
- L**
- Lashing down . . . . . 267
- Left side cover . . . . . 322  
     Attaching . . . . . 322  
     Removing . . . . . 322
- Lift cut out  
     Automatic . . . . . 129
- Lift mast  
     Lubricating the roller track . . . . . 346  
     Removing . . . . . 319  
     Securing against falling off . . . . . 319  
     Securing against tilting backwards . . 319
- Lift mast versions  
     Triplex lift mast . . . . . 135
- Lift mast vertical position . . . . . 130  
     Automatic approach . . . . . 132  
     Calibrating . . . . . 134  
     Description . . . . . 130  
     Display . . . . . 132  
     Possible restrictions . . . . . 133  
     Run-in to end stops . . . . . 132  
     Tilting the lift mast backwards . . . . . 133  
     Tilting the lift mast forwards . . . . . 132
- Lifting . . . . . 318
- Lifting system  
     Controlling using a double  
         mini-lever . . . . . 138  
     Controlling using a quadruple  
         mini-lever . . . . . 140  
     Controlling using a triple mini-lever . . 139  
     Controlling using the fingertip . . . . . 143  
     Controlling using the joystick 4Plus . . 141  
     Operating devices . . . . . 137
- Lighting  
     Switching on and off . . . . . 201
- List of abbreviations . . . . . 8

Load		ADBLUE QUALITY	260
Picking up	158	ADBLUE QUALITY URGENT!	260
Setting down	163	ADBLUE REFILL 5l	260
transporting	162	ADBLUE URGENT!	259
Load capacity	151	AIR FILTER	263
Load chains		ALTERNATOR	262
Cleaning	298	APPLY HANDBRAKE	249
Load measurement	152	ARE YOU SURE ?	255
Description	152	ASH LOAD	261
Execution	153	BRAKE SENSOR	250
Zero adjustment	107	CODE DENIED	250
Lubricating the joints and controls	334	COOLANT LEVEL	262
		CUTOUT MODE	259
		EMERGENCY SWITCH	252
<b>M</b>		EMPTY	262
Maintenance data table	313	EXH.GAS PURIFIER	258
Air conditioning	315	EXH.GAS PURIFIER PLEASE	
Air filter system	315	WAIT	259
Battery	313	EXH.GAS PURIFIER SERVICE!!!	259
Controls/joints	313	FUEL FILTER	261
Cooling system	315	GLOW	261
Drive axle	314	HYBRID SYSTEM	261
Electrical system	313	HYDRAULIC PUMP	261
Engine	315	LOWER FORKS	251
Exhaust gas treatment (SCR)	315	LPG AUTO. VALVE	263
Fuel tank	315	NOT VALID	258
General lubrication points	313	OIL PRESSURE	263
Hydraulic system	313	OVERHEATING	257
Lift mast	314	PARK. REG. ERROR	264
Load chains	314	PARK. REG. URGENT!!!	264
Steering axle	314	PARKING BRAKE ACTIVE	251
Tyres	313	PARKING BRAKE: APPLY	
Washer system	315	HANDBRAKE!	251
Maintenance work without special		REFERENCE CYCLE	253
qualifications	302	REGENERATION COMPLETED	263
Malfunctions during lifting mode	135	RELEASE PARKING BRAKE	251
Measuring the insulation resistance of		SAFETY BELT	254
the electrical system	40	SCR-SYSTEM MALFUNCTION	264
Medical equipment	36	SCR-SYSTEM SERVICE	264
Message		SEAT SWITCH	255
? VERTICAL POSITION	253	SERVICE BRAKE	249
ACCELERATOR	250	START IC ENGINE	265
ADBLUE FILLING LEVEL	260		

START PARK. REG.?	264	Overhead guard	
STEERING	252	Drilling	33
SURVEILLANCE	258	Roof loads	33
SWITCH OFF TRUCK?	251	Welding	33
TILTING SPEED	252	Overview	
Messages		Driver's compartment	55
Drive-specific	258	<b>P</b>	
General	249	Packaging	13
Mini console	63	Parked regeneration	
Misuse of safety systems	34	Interruption	168
MSG 65/MSG 75 driver's seat		Performing	169
Adjusting	76	Parking brake	124
Adjusting the backrest extension	79	Mechanical parking brake	124
Adjusting the lumbar support	78	Parking the truck securely	291
Adjusting the seat backrest	77	Particle filter	
Adjusting the seat suspension	78	Displays	173
Moving	77	Function	167
Switching the seat heater on and off	79	Low-load operation	168
<b>N</b>		Normal operation	168
Nameplate	66	Parked regeneration	169
Neutral position	116	Personnel qualifications	302
Note regarding exhaust gas treatment	2	Picking up loads	155
<b>O</b>		Place of use	17
Oil bath air filter		Pre-cleaner	
Cleaning the oil tank	331	Cleaning	331
Visual inspection	82	Visual inspection	81
Oils	41	Procedure if truck tips over	277
Opening the bonnet	320	Production number	67
Opening the cab door	212	Prohibition of use by unauthorised persons	30
Opening the side windows	213	Proper usage	16
Operating company	28	Push-up roof window	219
Operating devices for hydraulic and driving functions	57	<b>Q</b>	
Operating materials		Quadruple mini-lever	
Quality and quantity	312	Lifting/lowering the fork carriage	140
Operating procedures	11	Tilting the lift mast	140
Operating the service brake	123	<b>R</b>	
Operating the signal horn	99	Radio	216
Ordering spare parts and wearing parts	311	Rear window heating	215

Recommissioning after shutdown . . . . .	294	Seat belt . . . . .	99
Reducing speed when turning . . . . .	127	Checking . . . . .	335
Reducing speed with a raised load . . . . .	128	Cleaning . . . . .	336
Replacing the air filter cartridges . . . . .	332	Fastening . . . . .	100
Replacing the fuses . . . . .	343	Fastening on a steep slope . . . . .	101
Replacing the recirculated air filter for the heating system . . . . .	338	Maintaining . . . . .	335
Resetting the daily kilometres . . . . .	238	Malfunction due to cold . . . . .	101
Resetting the daily operating hours . . . . .	238	Releasing . . . . .	101
Residual dangers . . . . .	19	Replacement after an accident . . . . .	336
Residual risks . . . . .	19	Selecting the drive direction . . . . .	115
Retrofitting . . . . .	31	Selecting the driver PIN . . . . .	94
Reversible fork arm		Set values . . . . .	318
Checking . . . . .	349	Setting the date . . . . .	238
Reversible fork arms . . . . .	148	Setting the drive programme . . . . .	114
Right-hand service flap		Setting the language . . . . .	239
Closing . . . . .	325	Setting the time . . . . .	238
Opening . . . . .	324	Shutdown	
Roadways . . . . .	112–114	Recommissioning . . . . .	294
Rotating beacon . . . . .	202	Shutting down the truck . . . . .	292
Rules for roadways and the working area . . . . .	114	Special risks . . . . .	20
<b>S</b>		Spring-operated brake	
Safety devices . . . . .	318	Releasing . . . . .	280
Safety inspection . . . . .	38	Stability . . . . .	20
Safety regulations for maintenance		Starting drive mode	
General information . . . . .	316	Dual-pedal version . . . . .	120
Safety devices . . . . .	318	Starting the engine . . . . .	103
Set values . . . . .	318	Starting to drive . . . . .	118
Working on the electrical equip- ment . . . . .	317	Status LEDs . . . . .	236
Working on the hydraulic equip- ment . . . . .	316	Steering . . . . .	126
Working on the ignition system . . . . .	317	Steering system	
Safety regulations for working on the lift mast . . . . .	318	Checking for correct function . . . . .	106
Safety regulations when driving . . . . .	110	Storing the truck . . . . .	292
Safety regulations when handling loads . . . . .	150	StVZO (Road Traffic Licensing Regulations) information . . . . .	67
Schematic views . . . . .	11	Switching off the	
		air conditioning . . . . .	218
		Switching off the truck . . . . .	291
		Switching on the	
		air conditioning . . . . .	218
		Switching on the key switch . . . . .	86

<b>T</b>	
Technical data	
Dimensions	352
VDI datasheet	353
Three-way mini-lever	59
Topicality of the operating instructions	7
Towed load	220
Towing	268
Proper use	16
Trailers	
Towing	231
Transport	266
Transport of swinging loads	157
Transporting pallets	157
Triple mini-lever	
Lifting/lowering the fork carriage	139
Tilting the lift mast	139
Types of lift mast	134
Telescopic mast	134
Tyres	
Safety principles	34
<b>U</b>	
Using working platforms	18
<b>V</b>	
Variants	
Access authorisation with PIN code	89
Accident recorder	208
Automatic lift cut out	129
Automatic shut-off of the internal combustion engine	128
Clamp locking mechanism	196
Clipboard	219
Cruise control	208
Emergency off switch	86
FleetManager	207
Fork extension	146
Heating system	216
Lift mast vertical position	130
Lifting systems	129
Load measurement	152
Push-up roof window	219
Radio	216
Reducing speed with a raised load	128
Reversible fork arms	148
Triplex lift mast	135
Wheel chock	292
Windscreen wiper/washer	207
Zero braking	124
VDI datasheet	353
Vertical lift mast position	
Checking for correct function	109
View of functions and operations	11
View of operating procedures	11
Views of the display operating unit	12
Visual inspection	
Oil bath air filter	82
Pre-cleaner	81
Visual inspections	70
<b>W</b>	
Warning regarding non-original parts	33
Wheel chock	292

Wheels and tyres	
Checking air pressure . . . . .	341
Checking condition and wear of the tyres . . . . .	342
Checking wheel fastenings . . . . .	342
Servicing . . . . .	341
Windscreen wiper/washer . . . . .	207
Working at the front of the truck . . . . .	318
Working on the electrical equipment . . .	317
Working on the hydraulic equipment . . .	316
Working on the ignition system . . . . .	317
Working spotlights	
Automatically switching on/off . . . . .	206
Lift-height-controlled switching on/off . . . . .	206
Manually switching on/off . . . . .	205
Switching on and off . . . . .	202, 205
<b>Z</b>	
Zero adjustment of the load measure- ment . . . . .	107







STILL GmbH

57348011800 EN – 07/2016