

NOBLIFT 诺力



FE4P16-18N-BPT-001

⚠ WARNING

**Do not use the pallet truck before reading and understanding these operating instructions.
Keep for future reference.**

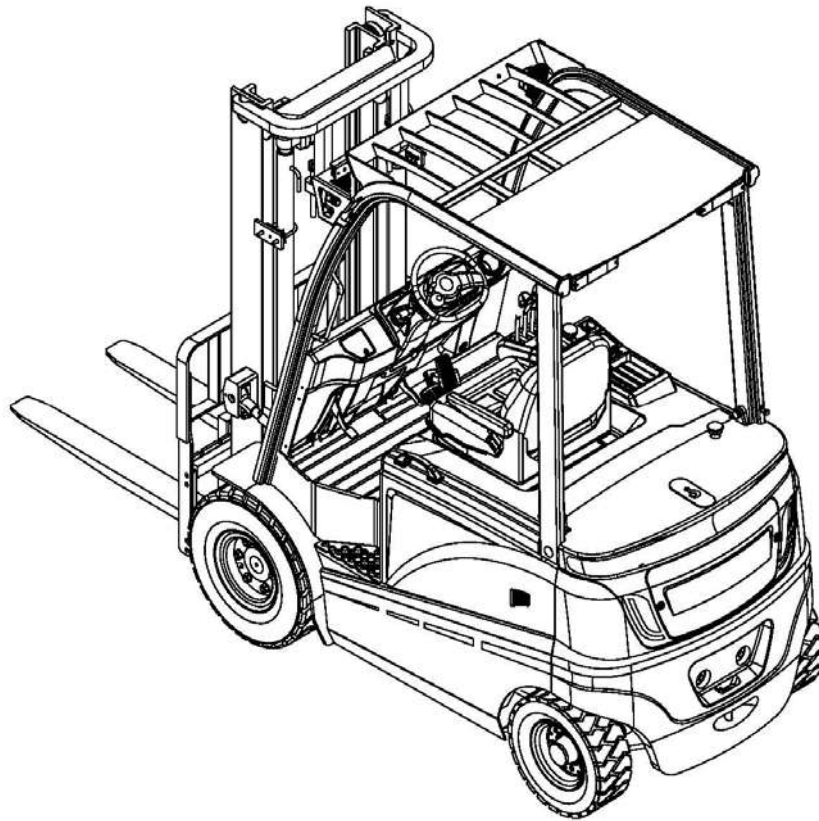

Spare Parts List

FE4P16-18 N series

battery counter balanced fork lift truck

Noblelift Equipment Joint Stock Co., Ltd

Forword

Welcome to use Noblelift counter balanced fork lift truck!

- 1、 This spare parts list includes all the parts of FE4P16-18 N series forklift truck.
- 2、 The user can refer the list according to the catalogue page.
- 3、 When repairing or replacing the spare parts, please use correct spare parts to ensure the truck quality.
- 4、 When ordering parts, please write clearly the truck type, manufacturing number, parts serial number and order quantity.

Note: ▲ Do not provide spare parts separately.

- 5、 In order to further optimize the product, we reserve the right to change our products. and without prior notice to you, please understand. If you want to know the latest product information, you can get the latest information from the company's sales and spare parts company.

Catalogue

	Forward.....	1
	Catalogue.....	2-3
1	Drive system.....	4-5
2	Drive axle.....	6-7
3	Gearbox	8-9
4	Differential mechanism	10-11
5	Drive wheel assembly.....	12-13
6	Lifting motor and installation.....	14-15
7	Battery and bracket.....	16-17
8	Foot pedal and installation.	18-19
9	Battery box cover.....	20-23
10	Right side door.....	24-25
11	Right side plate (hoisting frame).....	26-27
12	Left cover plate.....	28-29
13	Valve cover.....	30-31
14	Counter weight assembly.....	32-33
15	Frame (sidesway).....	34-35
16	Frame (ceiling mounted).....	36-37
17	Control panel.....	38-39
18	Steering mechanism and installation.....	40-41
19	Foot brake.....	42-43
20	Parking brake.....	44-47
21	Overhead guard and installation.....	48-49
22	Rearview mirror installation.....	50-51
23	Steering axle and installation.....	52-55
24	Steering cylinder.....	56-57
25	Steering wheel assembly.....	58-59
26	Working cylinder mechanism and installation	60-61
27	Multiple directional control valve (bigeminy).....	62-65
28	Multiple directional control valve (trigeminy).....	66-69
29	Multiple directional control valve(four joint).....	70-73
30	Hydraulic system	74-77
31	Mast lifting pipeline (standard mast)	78-79
32	Mast lifting pipeline(two stage full free lift).....	80-81
33	Mast lifting pipeline(three stage full free lift).....	82-85
34	Side shifter and pipeline installation (standard mast).....	86-87

35	Side shifter and pipeline installation(two stage full free).....	88-93
36	Side shifter and pipeline installation(three stage full free).....	94-97
37	Fork.....	98-99
38	Fork carrier(standard mast)	100-101
39	Fork carrier(two stage full free)	102-103
40	Fork carrier(three stage full free)	104-105
41	Mast (standard mast).....	106-109
42	Mast (two stage full free).....	110-113
43	Mast (three stage full free).....	114-117
44	Lifting cylinder(standard mast).....	118-123
45	Short lifting cylinder (two stage full free).....	124-129
46	Lifting cylinder(two stage full free)	130-133
47	Short lifting cylinder (three stage full free)	134-137
48	Short lifting cylinder (three stage full free)	138-141
49	Tilted cylinder.....	142-143
50	Electric system.....	144-147
51	Electroni ccontrol element CURTIS.....	148-149
52	Power connector assembly.....	150-151
53	Labels(Chinese).....	152-153
54	Labels(English).....	154-155
55	Data nameplate (Chinese).....	156-157
56	Data nameplate (English).....	158-159

Drive system

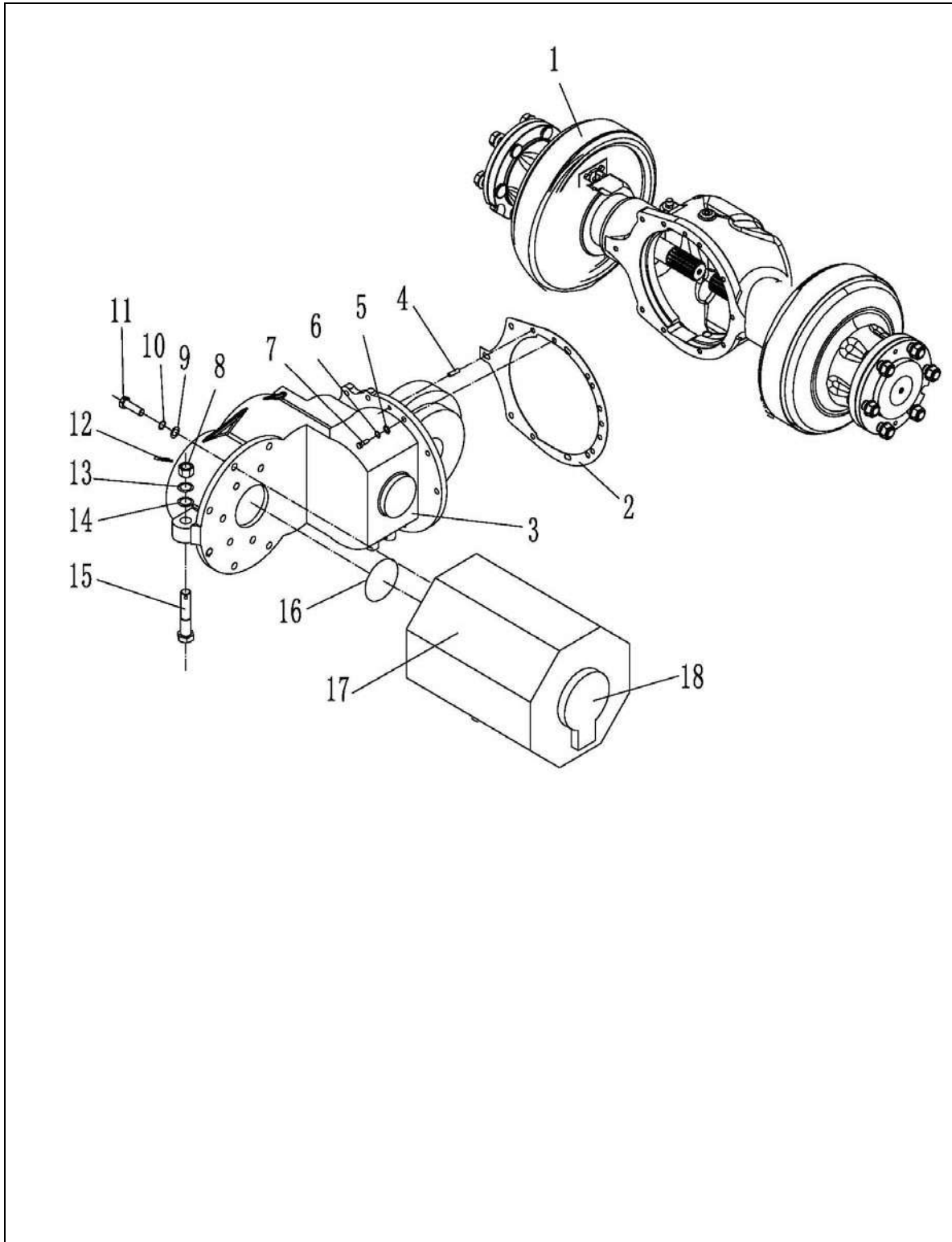

Fig. 1**Drive system**

No.	Coding	Description	Qty.	Note
1	254113510001	Drive axle	1	
2	255013520005	Seal washer	1	
3	255014010002	Gear box HDCSB30(middle of south)	1	
4	910600100021	Dowel pin GB119.2-8x25	1	
5	910400100007	Washer GB97.1-10-200HV	12	
6	910400500007	Washer GB93-10	12	
7	910100400004	Bolt GB5786-M10x1.25x30-8.8	12	
8	910300900002	Nut GB6178-M20-8	1	
9	910400100009	Washer GB97.1-14-200HV	5	
10	910400500009	Washer GB93-14	5	
11	910100200010	Bolt GB5785-M14x1.5x50-8.8	5	
12	910600600037	Split pin GB91-4x40	1	
13	910400500012	Washer GB93-20	9	
14	910400100012	Washer GB97.1-20-200HV	1	
15	910100500006	BoltGB31.1-M20x90-8.8	1	
16	910800100020	O ring 90x2.65	1	
17	254132010001	Motor (AC) HPQ6.8-4NL	1	
	254132010002	Motor (AC) YDQ6.8-1-4HC	1	optional
18	255098513251	Encoder SNDH-T4L-G01	1	accessories

Drive axle

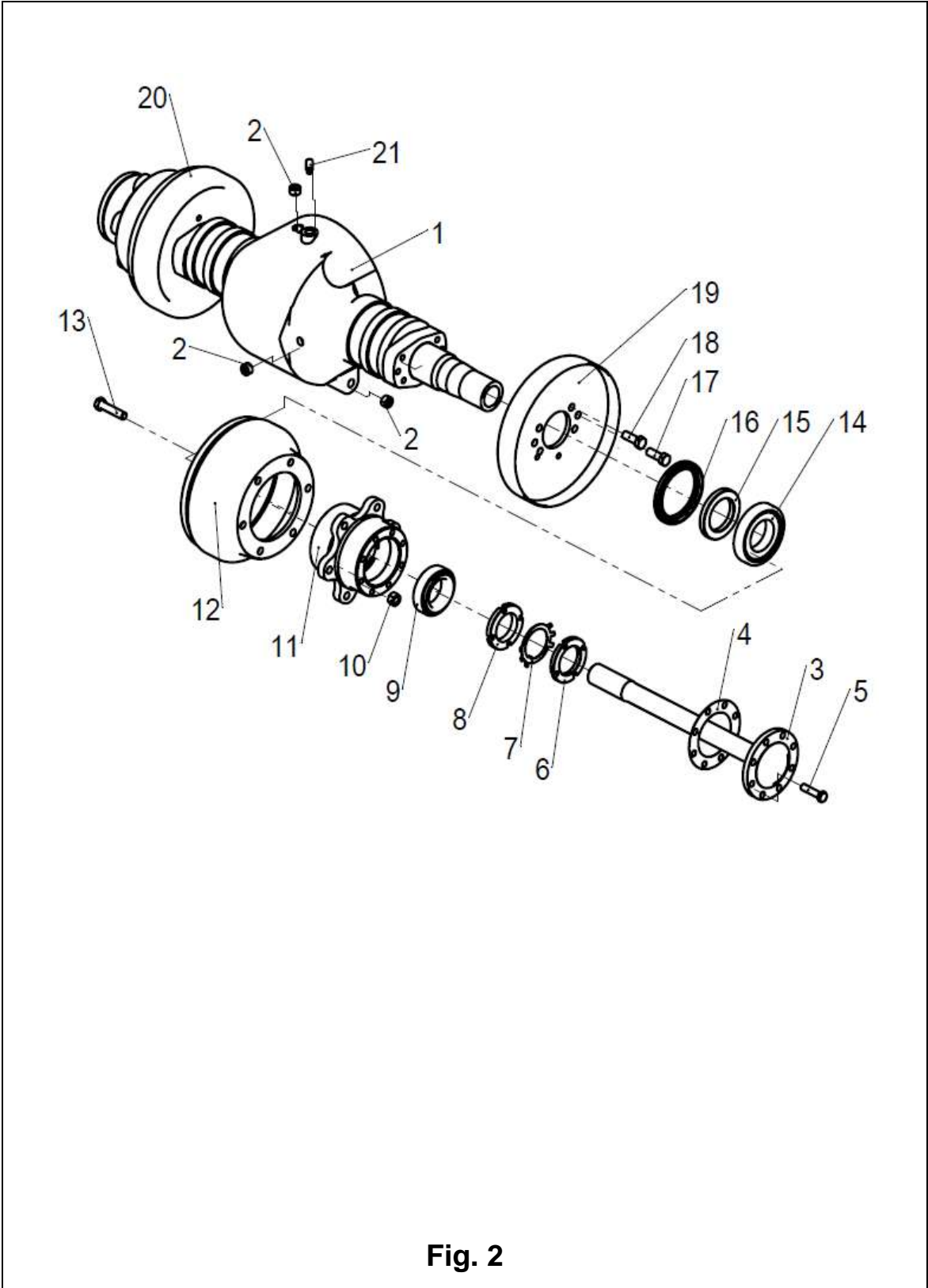

Fig. 2

Fig. 2**Drive axle**

No.	Coding	Description	Qty.	Note
A	255013510001	Drive axle	1	
1	254198523505	axle housing	1	
2	255098523504	Blocking	1	
3	254198523522	Half shaft	2	
4	254198523521	Half shaft seal washer	1	
5	255098523502	Half shaft Bolt	16	
6	255098523507	Little round nut	4	
7	254198523509	round nut Brake gasket	4	
8	254198523506	separate cover	5	
9	254198023513	Bearing Oil seal assembly 33012A	2	
10	253098526041	Rim nut(M14X1.5)	12	
11	254198523519	Hub	2	
12	254198523512	Brake drum	2	
13	254198523520	Hub connecting bolt	12	
14	254198523514	Bearing30213E	2	
15	254198523515	Bearing circlip	2	
16	254198523516	Oil seal SG100x125x12	2	
17	254198523510	Brake Hinge system bolt M14×1.5×40	4	
18	254198523511	Brake bolt M14×1.5×40	12	
19	254198513501	Left brake assembly	1	
20	254198513508	Right brake assembly	1	
21	254198523503	Air hole assembly	1	

Gear box

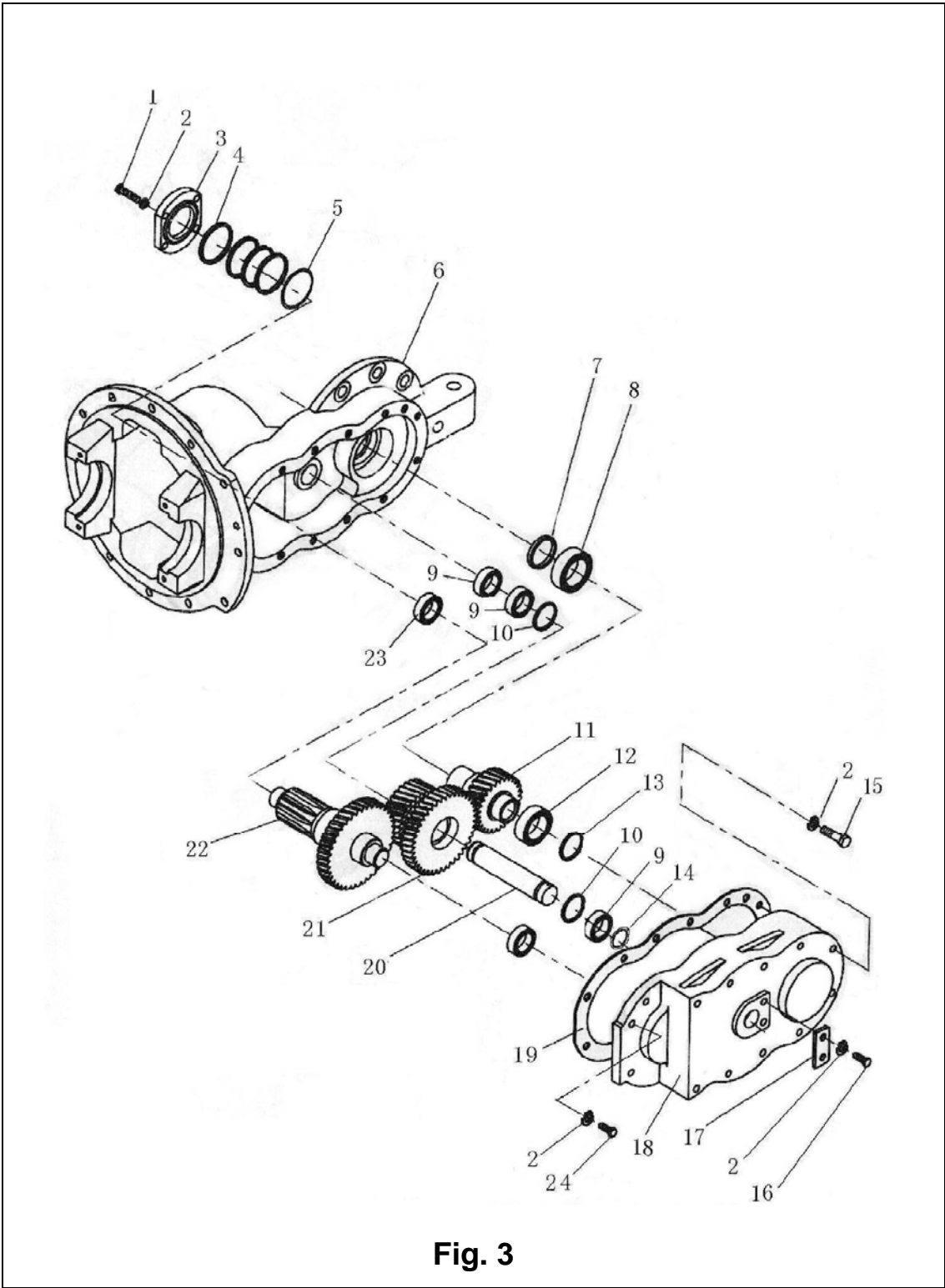

Fig. 3

Fig. 3**Gearbox**

No.	Coding	Description	Qty.	Note
A	255014010002	Gearbox	1	
1	255098524001	Bolt	4	
2	255098524002	Spring washer	20	
3	255098524003	Bearing cap	1	
4	255098524004	Spacer	4	
5	255098524005	O seal ring	1	
6	255098524006	Box	1	
7	255098524007	Oil seal	1	
8	255098524008	Bearing	1	
9	255098524009	Bearing	3	
10	255098524010	O seal ring	2	
11	255098524011	Input shaft assembly	1	
12	255098524012	Bearing	1	
13	255098524013	Adjusting washer	0	
14	255098524014	Adjusting washer	0	
15	255098524015	Bolt	12	
16	255098524016	Bolt	2	
17	255098524017	Stop dog	1	
18	255098524018	Box cover	1	
19	255098524019	Paper pad	1	
20	255098524020	axle	1	
21	255098524021	Gear	1	
22	255098524022	Gear assembly	1	
23	255098524023	Bearing	2	
24	255098524024	Bolt	2	

Differential mechanism

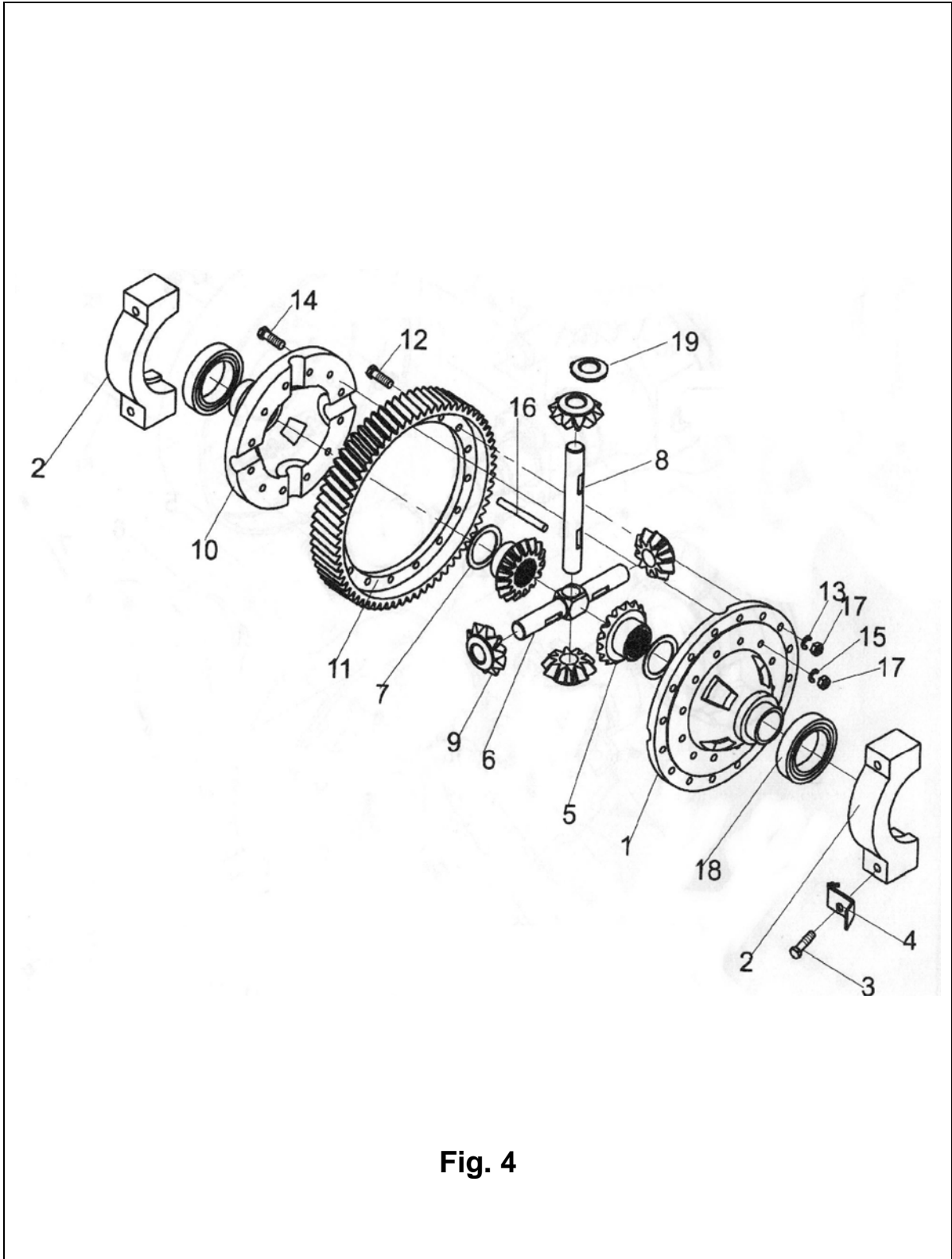

Fig. 4

Fig.4 Differential mechanism

No.	Coding	Description	Qty.	Note
1	255098524024	Left differential carrier	1	
2	255098524025	Bearing seat	2	
3	255098524026	Bolt	4	
4	255098524027	Locking plate	4	
5	255098524028	Gear	2	
6	255098524029	Axle	1	
7	255098524030	Washer	2	
8	255098524031	Gear axle(II)	0	
9	255098524032	Gear	4	
10	255098524033	Right differential carrier	1	
11	255098524034	Gear ring	1	
12	255098524035	Washer	4	
13	255098524036	Spacer	6	
14	255098524037	Bolt	12	
15	255098524038	Bearing	2	
16	255098524039	Dowel pin	0	
17	255098524040	Nut	12	

Drive wheel assembly

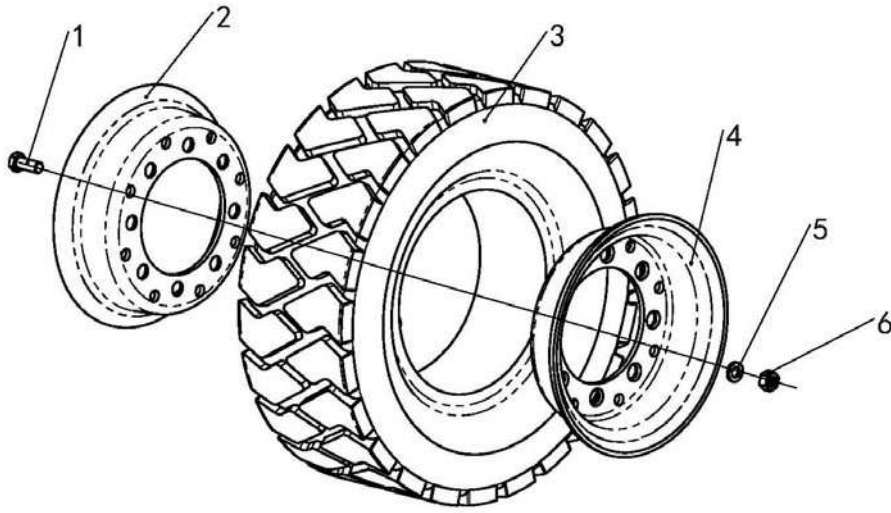

Fig. 5

Fig.5 Drive wheel assembly

No.	Coding	Description	Qty.	Note
A	251013010010	Drive wheel assembly 6.50-10-10PR (gas filled)	2	
	251013010011	Drive wheel assembly 6.50-10 (gas filled)	2	Optional
	251013010012	Drive wheel assembly 6.50-10 (gas filled)	2	Optional
1	252013020001	Rim bolt M12x26	12	
2	251013020001	outer Rim 5.00F-10	2	
3	251013010002	Pneumatic tyre6.50-10-10PR	2	
	251013010003	Solid tyre 6.50-10	2	Optional
	251013010007	Environmental protection tyre 6.50-10	2	Optional
4	251013020002	Inside Rim 5.00F-10	2	
5	910400500008	Spring washer 12	12	
6	910300100008	Nut GB6170-M12-10	12	

Lifting motor and installation

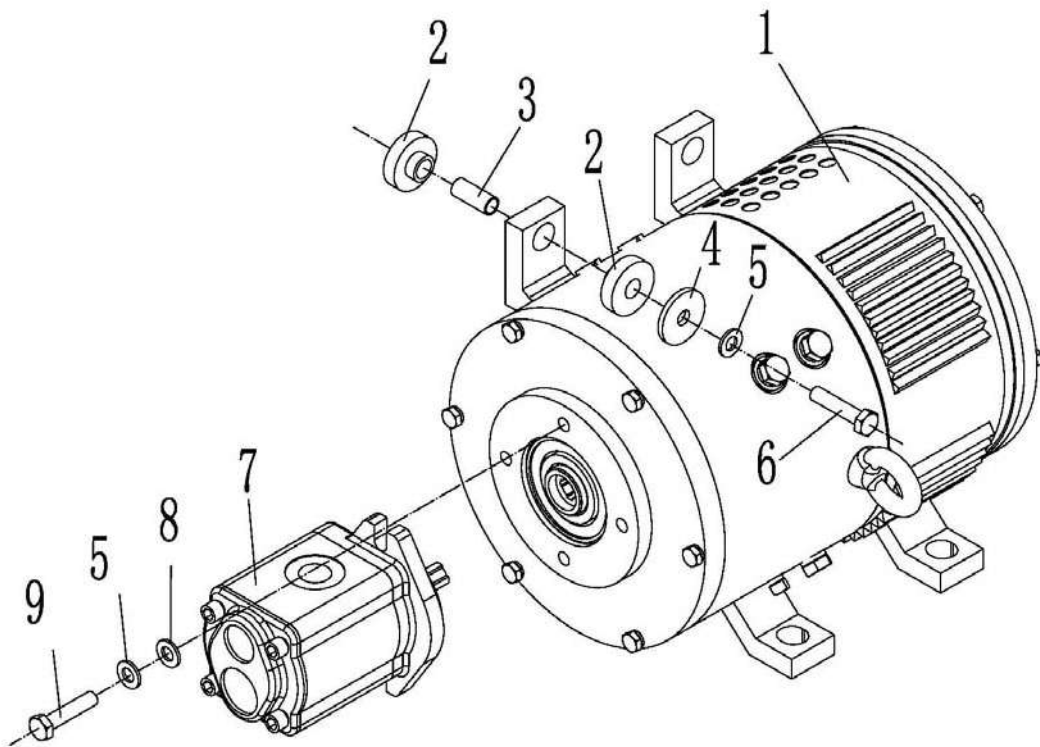

Fig. 6

Fig. 6 **Lifting motor and installation**

No.	Coding	Description	Qty.	Note
1	920900100038	Motor(AC)HPB8.6-4NL	1	Optional
	920900100041	Motor(AC)YDB8-6-4	1	Optional
	25098513252	Encoder SNDH-T4L-G01	1	Spare parts
2	255032520003	Anti vibration pad	8	
3	255032520001	Bushing	4	
4	255032520002	Washer $\phi 40 \times \phi 11 \times 4$	4	
5	910400500007	Washer GB93-10	6	
6	910100100034	BoltGB5782-M10x55-8.8	4	
7	255023510006	Gear pump	1	
8	910400100007	Washer GB97.1-10-200HV	2	
9	910100300039	Bolt GB5783-M10x40-8.8	2	

Battery and bracket

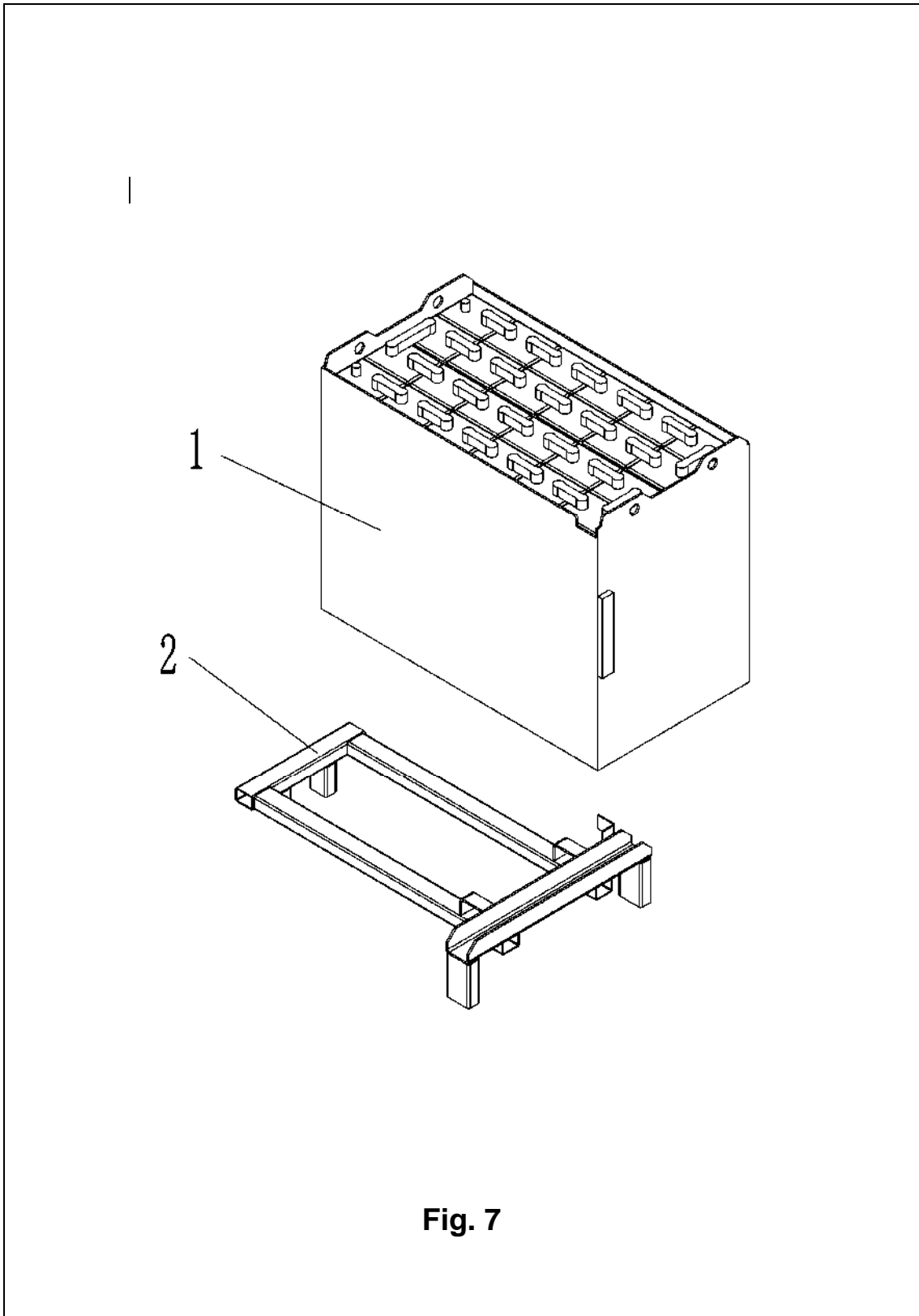

Fig. 7 Battery and bracket

No.	Coding	Description	Qty.	Note
1	254137010010	Battery (48V400Ah) (weld,kuile)	1	
	254137010011	Battery (48V450Ah) (weld,kuile)	1	Optional
	254137010012	Battery (48V500Ah) (weld,kuile)	1	Optional
	254137010013	Battery (48V400Ah) (weld,huoju)	1	Optional
	254137010014	Battery (48V450Ah) (weld,huoju)	1	Optional
	254137010015	Battery (48V500Ah) (weld,huoju)	1	Optional
	254137010016	Battery (48V400Ah) (bolt,kuile)	1	Optional
	254137010017	Battery (48V450Ah) (bolt,kuile)	1	Optional
	254137010018	Battery (48V500Ah) (bolt,kuile)	1	Optional
	254137010019	Battery (48V400Ah) (bolt,huoju)	1	Optional
	254137010020	Battery (48V450Ah) (bolt,huoju)	1	Optional
	254137010021	Battery (48V500Ah) (bolt,huoju)	1	Optional
	254137010022	Battery (48V450Ah) (weld,huoju)	1	Optional
	254137010023	Battery (48V500Ah) (bolt,huoju)	1	Optional
	254137010024	Battery (48V450Ah)(bolt ,FAAM)	1	Optional
254137010025	Battery (48V500Ah)(bolt ,FAAM)	1	Optional	
2	254112510001	Battery bracket welding	1	

Foot pedal

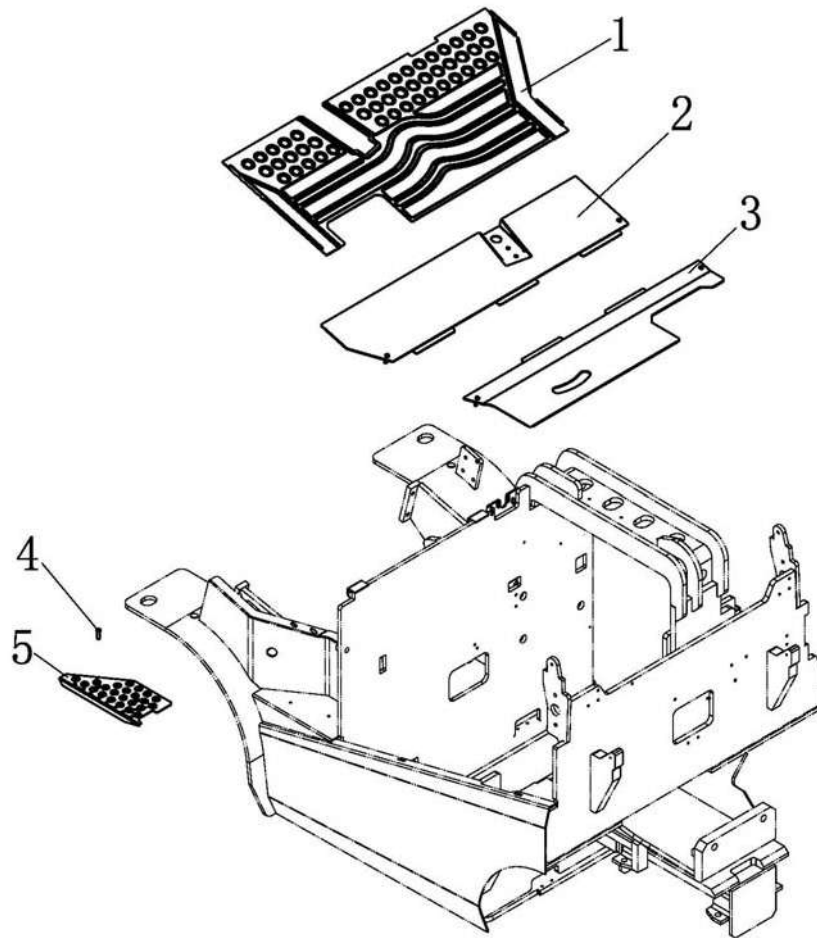

Fig. 8

Fig. 8 **Foot pedal**

No.	Coding	Description	Qty.	Note
1	255018020005	Cushion	2	
2	255018010001	Floor welding (front)	1	
3	255018010002	Floor welding (rear)	1	
4	941100100001	Screw M8x12-8.8	2	
5	255018020006	Foot pedal	1	

Battery box cover

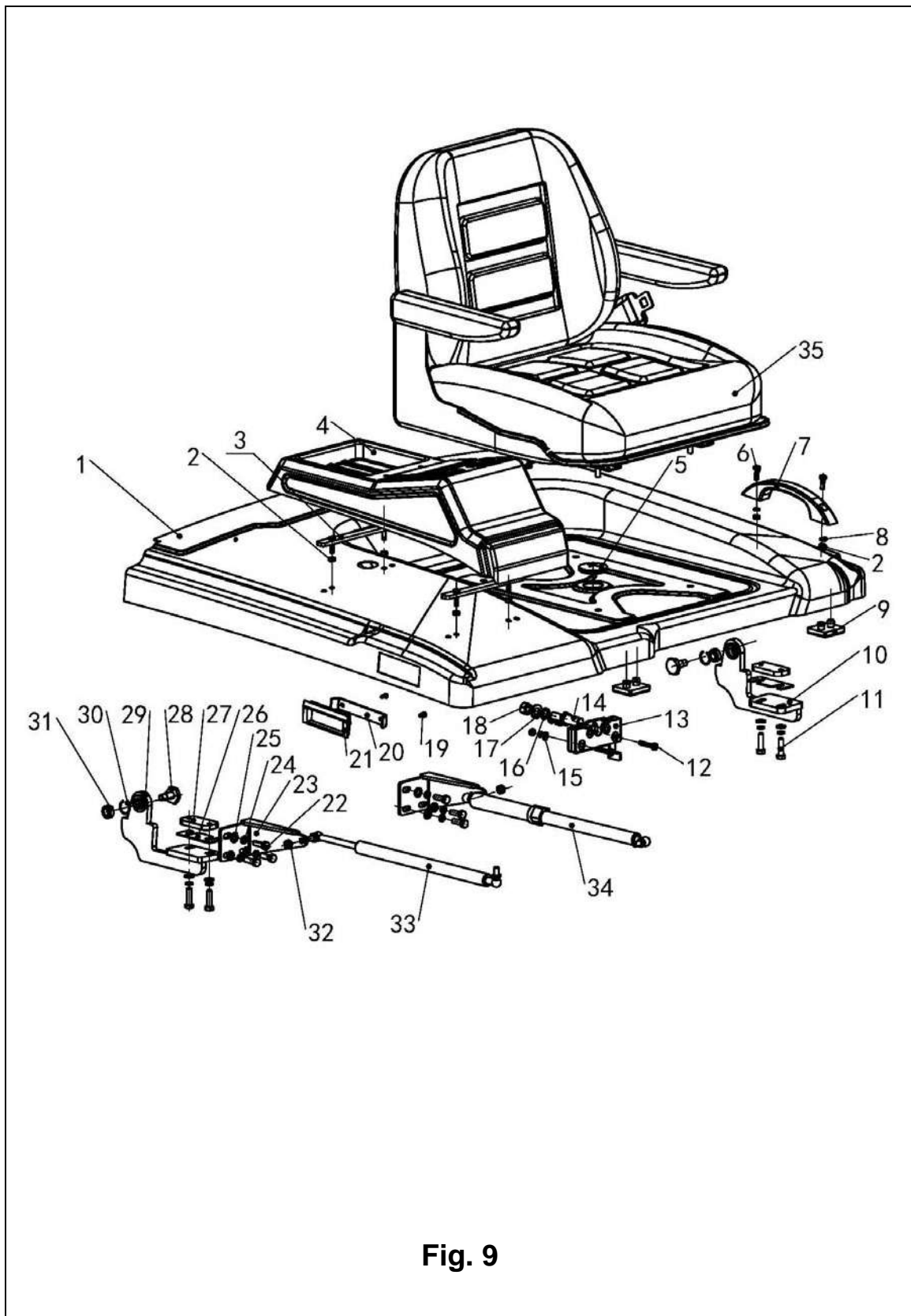

Fig. 9

Fig. 9 Battery box cover

No.	Coding	Description	Qty.	Note
1	255021010002	Battey box cover welding	1	
2	910300100005	Nut GB6170-M6-10	8	
3	255021010016	Pressing plate weiding	2	
4	255021020003	Trim	1	
5	255021020046	Guard cicle ϕ 35	1	
6	910200500053	ScrewGB818-M6x20-4.8	2	
7	255021020020	Handle	1	
8	910400500005	WasherGB93-6	4	
9	253521020013	Damping pad	2	
10	255021010005	Hinge welding (left)	1	
11	910100300024	Bolt GB5783-M8x30-8.8	4	
12	910200500056	Screw GB818-M6x35-4.8	2	
13	255021010010	Head cover lock	1	
14	255021020052	Lock tongue 2	1	
15	910400100005	Washer GB97.1-6-200HV	2	
16	910400500008	WasherGB93-12	1	
17	910400100008	WasherGB97.1-12-200HV	1	
18	910300100008	Nut GB6170-M12-10	1	
19	910200500021	Screw GB818-M4x10-4.8	2	
20	255021020055	Fixing plate	1	
21	255021020021	Handle(inside)	1	
22	910100300023	Bolt GB5783-M8x25-8.8	6	
23	255021020047	Holder	2	
24	910400500006	Washer GB93-8	10	
25	910400100006	Washer GB97.1-8-200HV	10	

Battery box cover

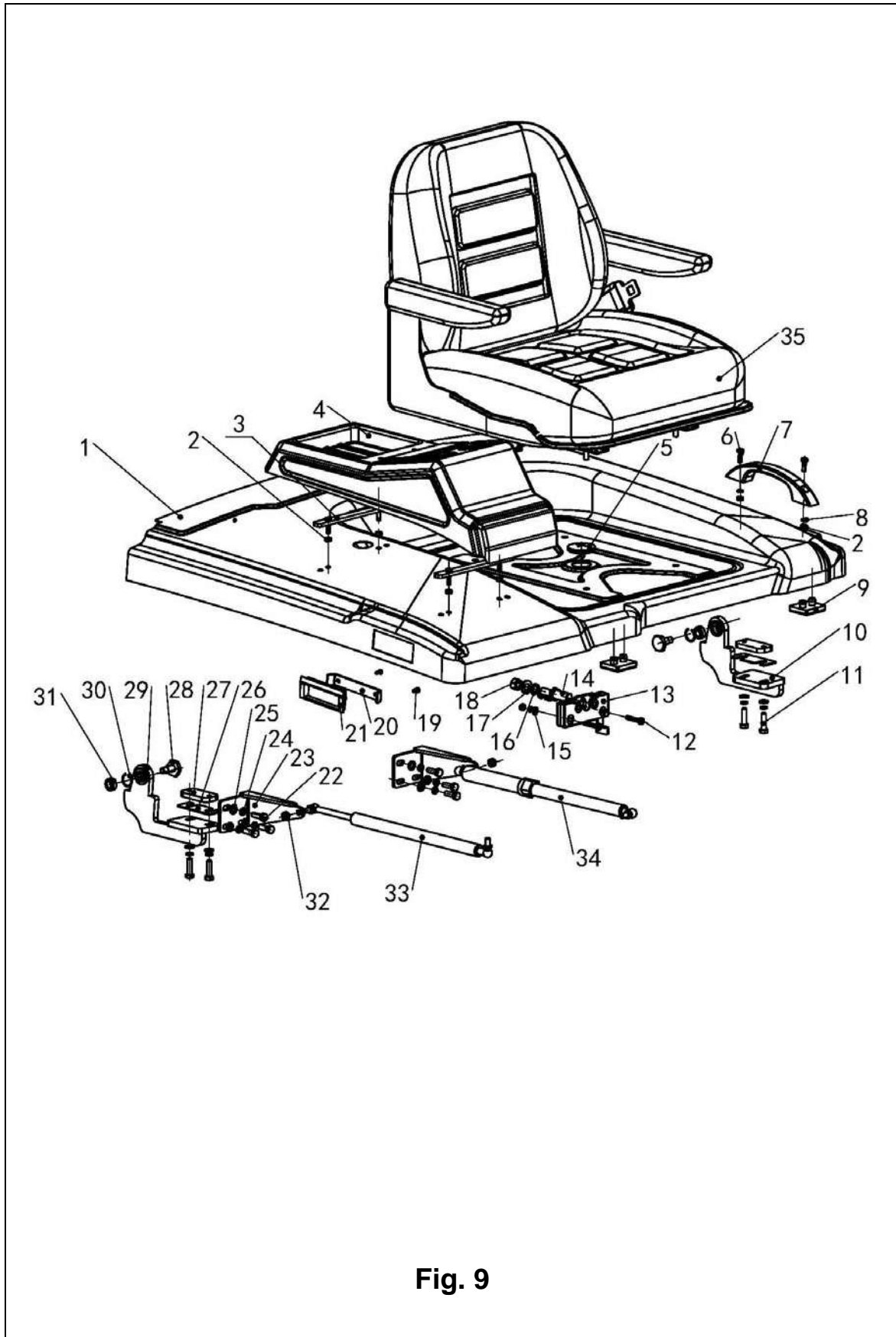

Fig. 9

Fig. 9 **Battery box cover**

No.	Coding	Description	Qty.	Note
26	255021020054	Adjusting pad	2	
27	255021020045	Bed plate	2	
28	255021020043	Bolt	2	
29	255021010006	Hinge welding (right)	1	
30	910401500001	Circlip GB895.1-22	2	
31	255021010014	BearingGE12E	2	
32	910300100006	NutGB6170-M8-10	2	
33	255021010011	Air spring350N(D200)	1	
34	255021010012	Air spring350N(D200)-lock oneself	1	
35	251037510001	Seat(benfeng BF1-ABC)	1	
	255037510001	Seat (benfeng BF2-2(A))	1	Optional

Right side door

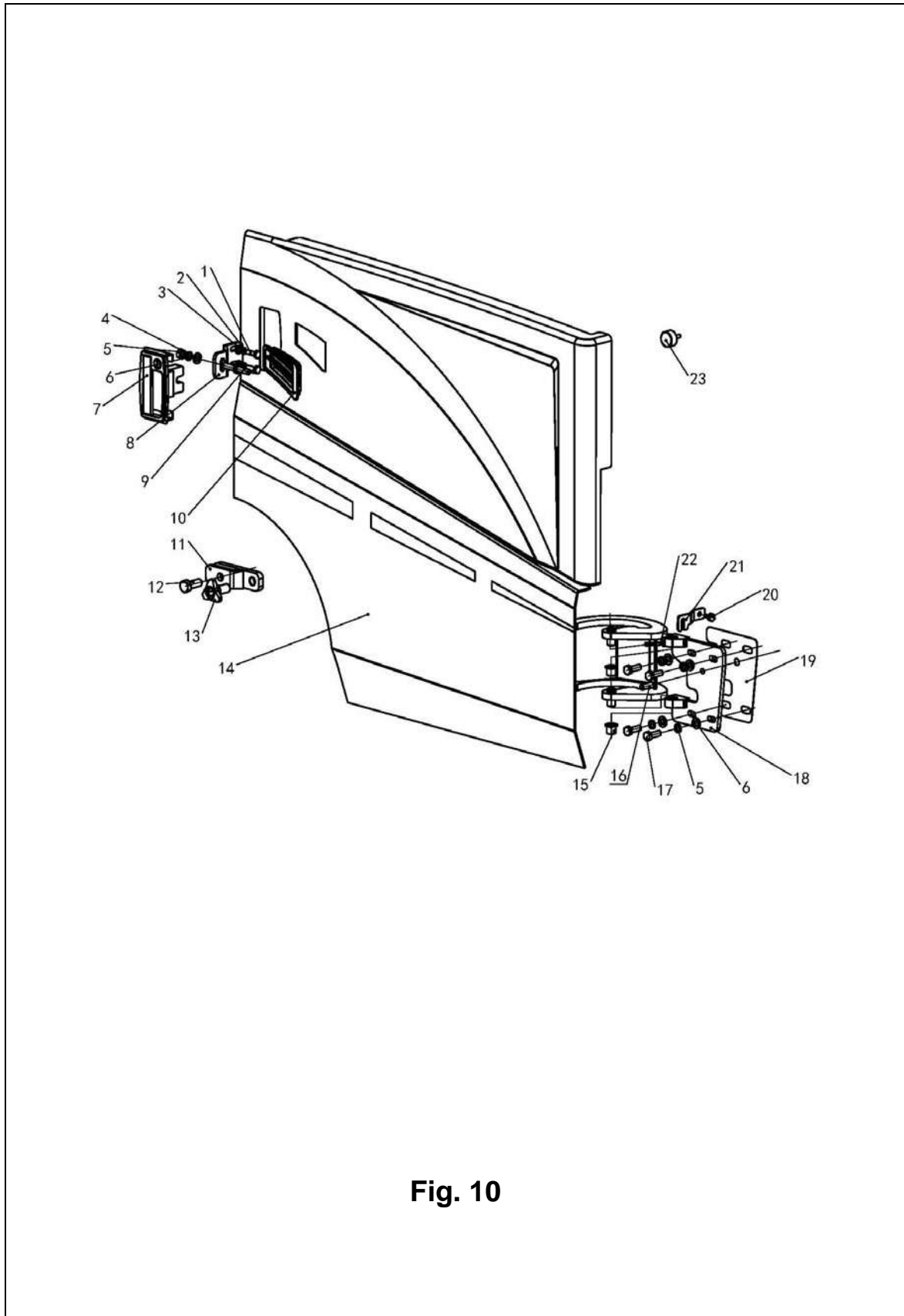

Fig. 10

Fig. 10**Right side door**

No.	Coding	Description	Qty.	Note
1	910100300023	Bolt GB5783-M8x25-8.8	2	
2	910400500006	Washer GB93-8	2	
3	910400100006	Washer GB97.1-8-200HV	2	
4	910300100007	Nut GB6170-M10-10	1	
5	910400500007	Washer GB93-10	5	
6	910400100007	Washer GB97.1-10-200HV	5	
7	255021010009	Side door lock	1	
8	255021020039	Fixing plate	1	
9	255021020040	Lock tongue 1	1	
10	505621520041	Air hole (left)	1	
11	255021010007	Limit seat welding	1	
12	910100300063	Bolt GB5783-M14x35-8.8	2	
13	255021020059	Star shaped handle	1	
14	255021010001	Side door welding (right)	1	
15	940500200016	Bushing 16x18x16-SF-1	2	
16	910600100031	Dowel pin GB119.2-10x30	1	
17	910100300037	Bolt GB5783-M10x30-8.8	4	
18	255021010004	Hinge seat welding	1	
19	255021020044	Adjusting washer	1	
20	255021020042	Bolt	1	
21	255021020041	Limit plate	1	
22	910100300014	Bolt GB5783-M6x35-8.8	1	
23	505618020016	Damping pad	1	

Right side plate (hoisting frame)

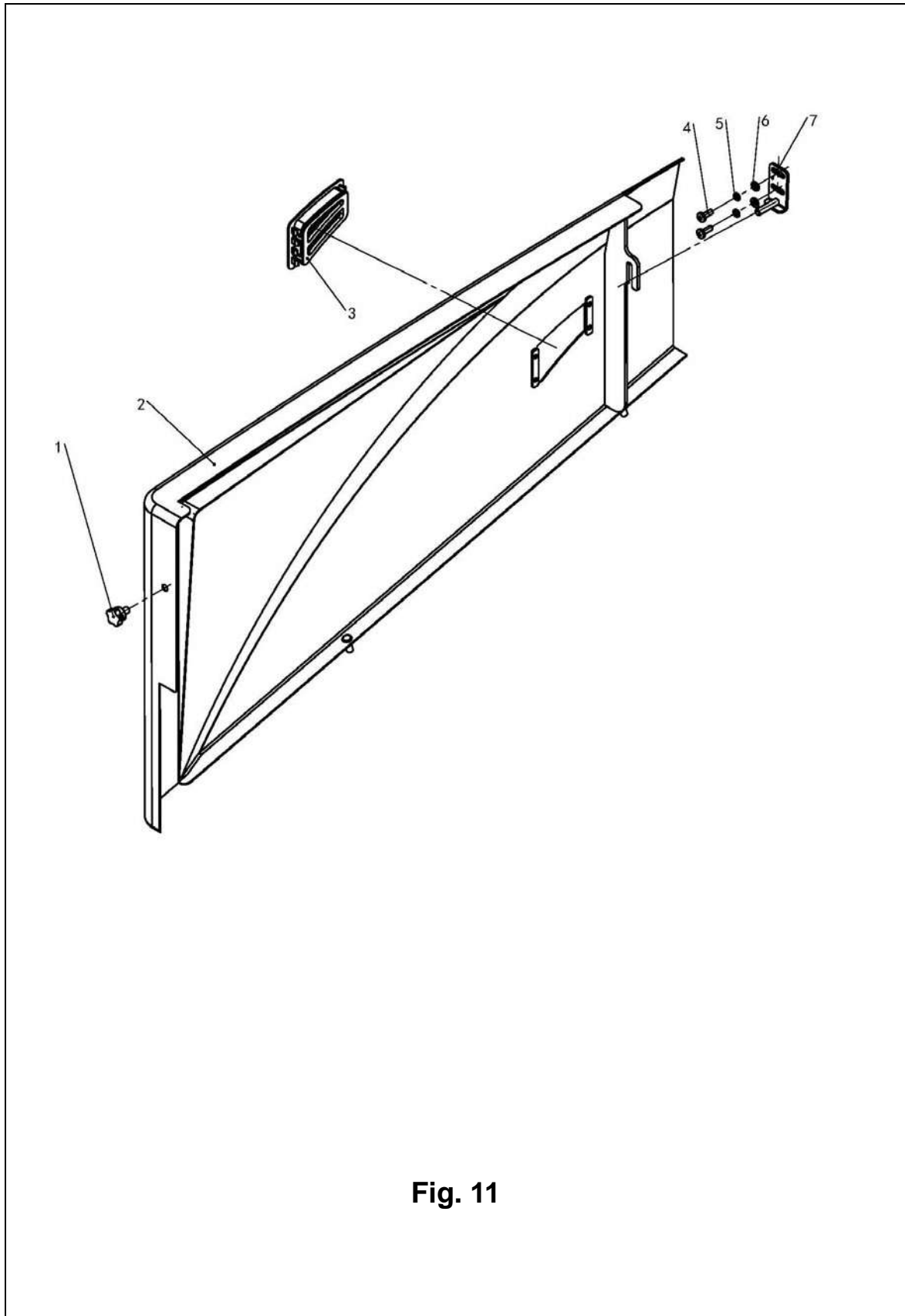

Fig. 11

Fig. 11 Right side plate (hoisting frame)

No.	Coding	Description	Qty.	Note
1	255021020060	Star shaped handle GB/T7274.4-12x50	1	
2	255021010017	Side plate welding (right)	1	
3	505621520041	Air hole (left)	1	
4	910200500052	Screw GB818-M6x16-4.8	2	
5	910400500005	Washer GB93-6	2	
6	910400100005	Washer GB97.1-6-200HV	2	
7	255021010015	Hook welding (left)	1	

Left cover plate

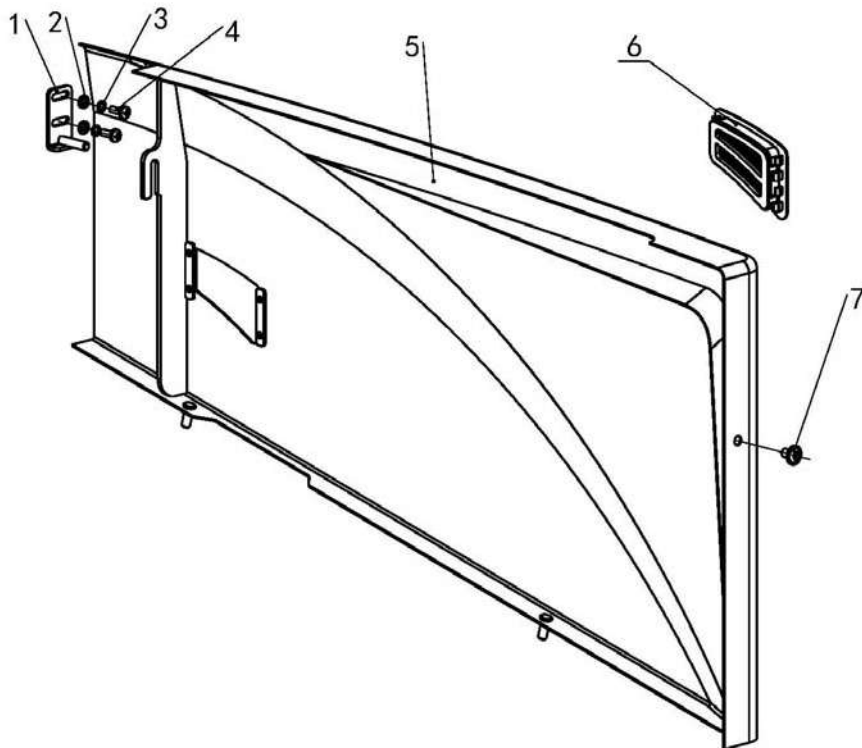

Fig. 12

Fig. 12 **Left cover plate**

No.	Coding	Description	Qty.	Note
1	255021010015	Hook welding (left)	1	
2	910400100005	Washer GB97.1-6-200HV	2	
3	910400500005	Washer GB93-6	2	
4	910200500052	Screw GB818-M6x16-4.8	2	
5	255021010003	Side plate welding (left)	1	
6	505621510004	Air hole (right)	1	
7	255021020060	Bolt	1	

Valve cover

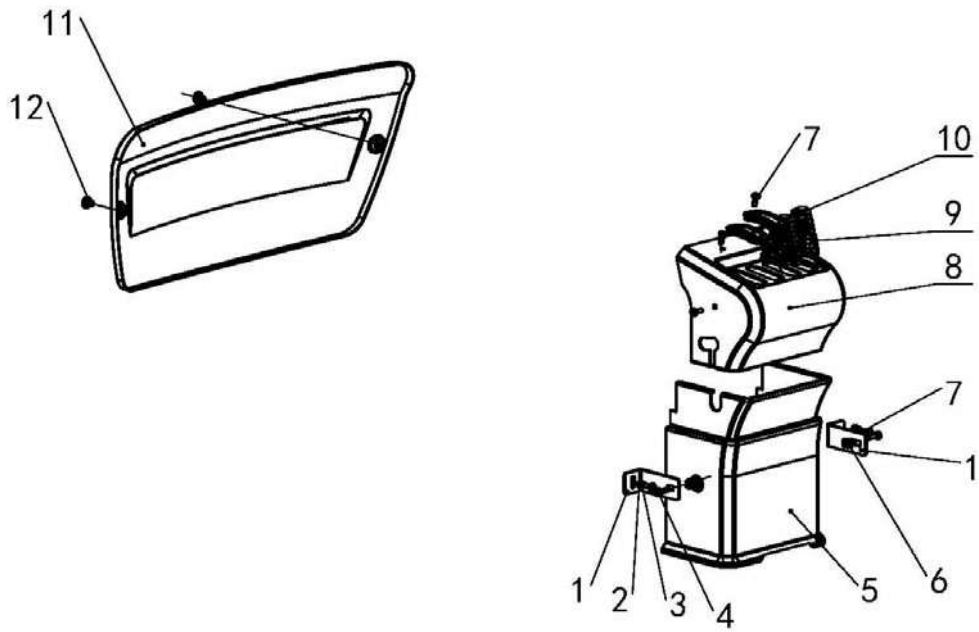

Fig. 13

Fig. 13**Valve cover**

No.	Coding	Description	Qty.	Note
1	255021020051	Holder	2	
2	910400100005	Washer GB97.1-6-200HV	2	
3	910400500005	Washer GB93-6	2	
4	910200500053	Screw GB818-M6x20-4.8	2	
5	255021020002	Protective cover 1	1	
6	255021020058	M6 Nut	4	
7	910200500052	ScrewGB818-M6x16-4.8	6	
8	255021020001	Protective cover 2	1	
9	253521020012	Rubber sheath	2	
10	253521020011	Cap	2	
11	255021020017	Cover	1	
12	941100100001	ScrewM8X12-8.8	2	

Counter weight assembly

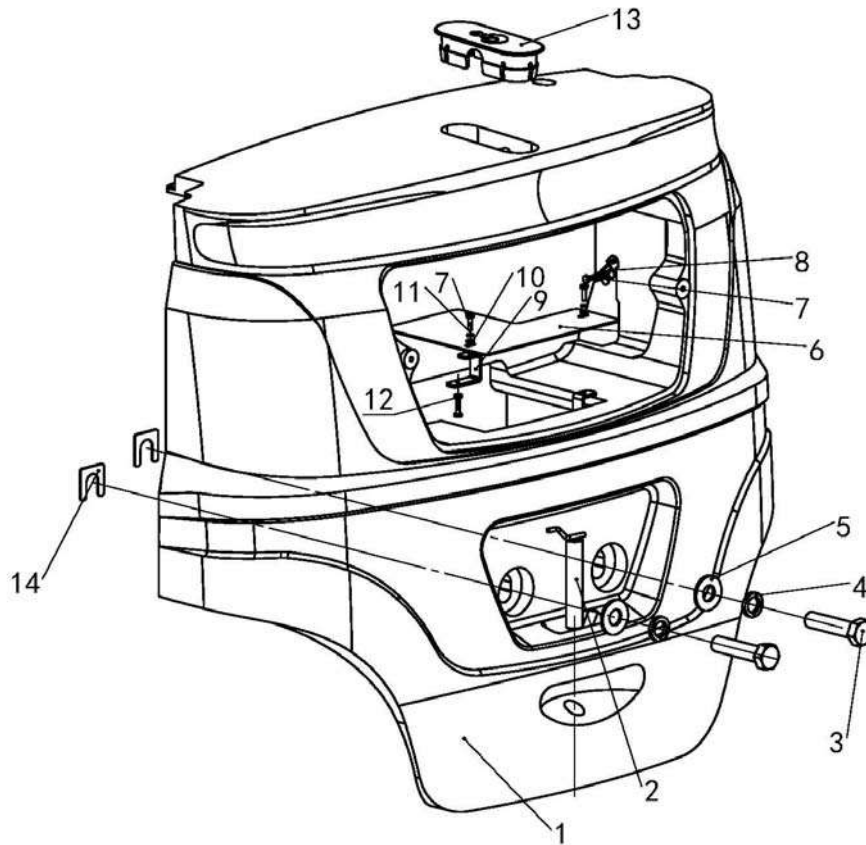

Fig. 14

Fig. 14 Counter weight assembly

No.	Coding	Description	Qty.	Note
1	254123020001	Counter weight (1.6t)	1	1.6t
	254223020001	Counter weight (1.8t)	1	1.8t
2	251023010002	Pin	1	
3	910100100101	Bolt GB5782-M24x100-8.8	2	
4	910400500013	Washer GB93-24	2	
5	251023020003	Spacer	2	
6	254123020005	Dust plate	1	
7	910100300011	Bolt GB5783-M6x20-8.8	6	
8	255023020006	Spacer	2	
9	255023020004	Splint	2	
10	910400100005	Washer GB97.1-6-200HV	4	
11	910400500005	Washer GB93-6	4	
12	910300100005	NutGB6170-M6-10	2	
13	255023020002	Cap	1	
14	255023020003	Spacer	2	

Frame(sideway)

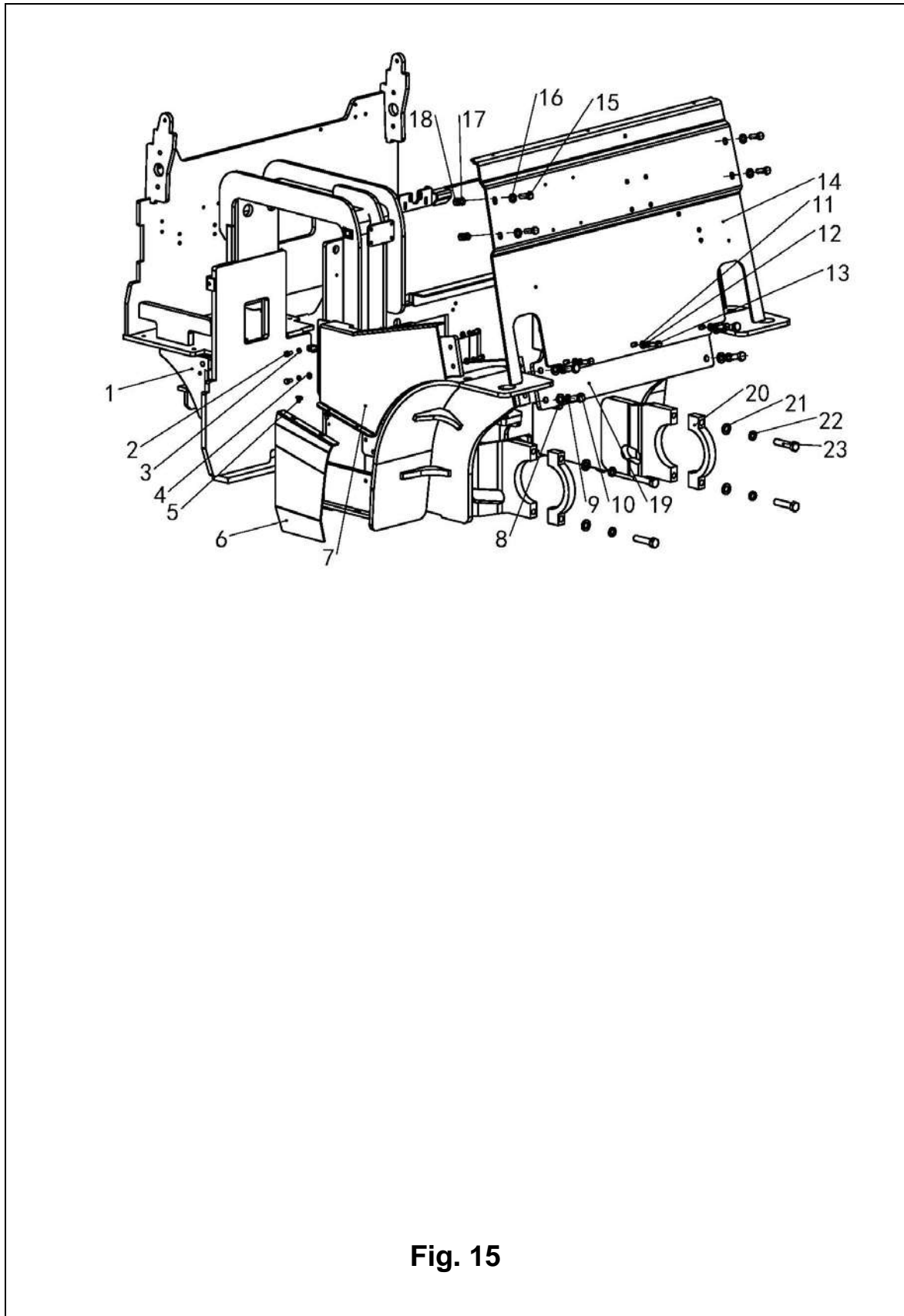

Fig. 15

Fig. 15 **Frame(sidesway)**

No.	Coding	Description	Qty.	Note
1	254121510020	Frame welding (middle of south)	1	
2	910100300020	Bolt GB5783-M8x16-8.8	4	
3	910400500006	Washer GB93-8	4	
4	910400100006	Washer GB97.1-8-200HV	4	
5	941100100001	Screw M8X12-8.8	2	
6	255021510004	Side plate welding	1	
7	255021510001	Baffle welding	1	
8	910400100009	Washer GB97.1-14-200HV	4	
9	910400500009	Washer GB93-14	4	
10	910100300063	Bolt GB5783-M14x35-8.8	4	
11	910400100007	Washer GB97.1-10-200HV	3	
12	910400500007	Washer GB93-10	3	
13	910100300037	Bolt GB5783-M10x30-8.8	3	
14	255021510009	Indicator welding	1	
15	910100300051	BoltGB5783-M12x35-8.8	4	
16	910400100008	Washer GB97.1-12-200HV	4	
17	910400500008	Washer GB93-12	4	
18	910300100008	Nut GB6170-M12-10	4	
19	254121510010	Plate welding	1	
20	251021520001	Cover	2	
21	910400100010	Washer GB97.1-16-200HV	4	
22	910400500012	Washer GB93-8	4	
23	910100200016	Bolt GB5785-M16x1.5x70-8.8	4	

Frame (ceiling mounted)

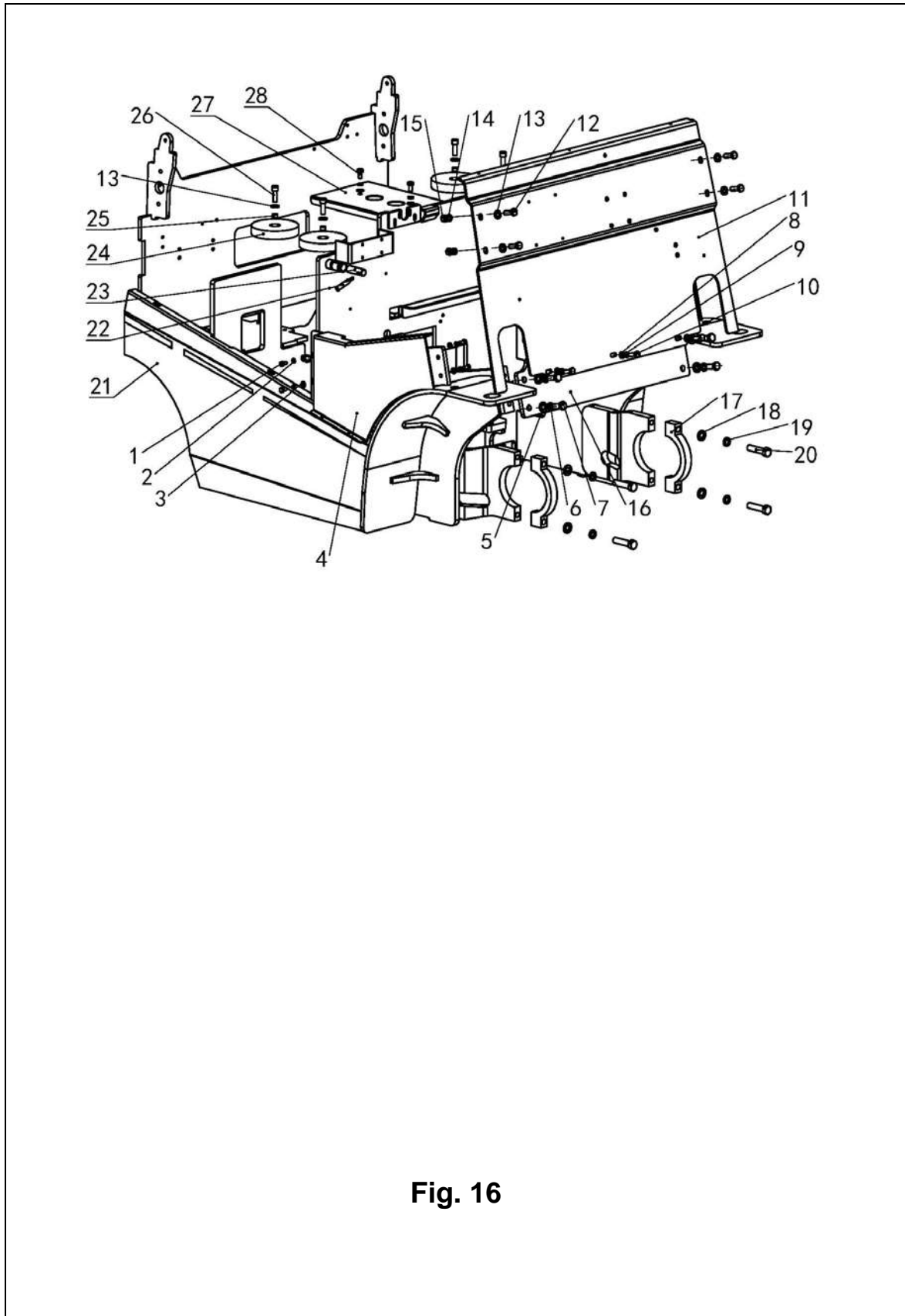

Fig. 16

Fig. 16 **Frame (ceiling mounted)**

No.	Coding	Description	Qty.	Note
1	910100300020	Bolt GB5783-M8x16-8.8	4	
2	910400500006	Washer GB93-8	4	
3	910400100006	Washer GB97.1-8-200HV	4	
4	255021510001	Baffle welding	1	
5	910400100009	Washer GB97.1-14-200HV	4	
6	910400500009	Washer GB93-14	4	
7	910100300063	Bolt GB5783-M14x35-8.8	4	
8	910400100007	Washer GB97.1-10-200HV	5	
9	910400500007	Washer GB93-10	5	
10	910100300037	Bolt GB5783-M10x30-8.8	3	
11	255021510009	Indicator holder welding	1	
12	910100300051	Bolt GB5783-M12x35-8.8	4	
13	910400100008	Washer GB97.1-12-200HV	8	
14	910400500008	Washer GB93-12	4	
15	910300100008	Nut GB6170-M12-10	4	
16	254121510010	Plate welding	1	
17	251021520001	Cover	2	
18	910400100010	Washer GB97.1-16-200HV	4	
19	910400500012	Washer GB93-20	4	
20	910100200016	Bolt GB5785-M16x1.5x70-8.8	4	
21	254121510021	Frame welding (ceiling mounted)	1	
22	255021520100	Dial rod	1	
23	255021520099	Safe pin	1	
24	253521520062	Anti vibration pad $\phi 140 \times \phi 13 \times 25$	4	
25	253521520063	Spacer $\Phi 14.5 \times \Phi 12.2 \times 10$	4	
26	910200200099	Screw GB70.1-M12x35-8.8	4	
27	254121520101	Cover plate	1	
28	910100300035	Bolt GB5783-M10x30-8.8	2	

Control panel

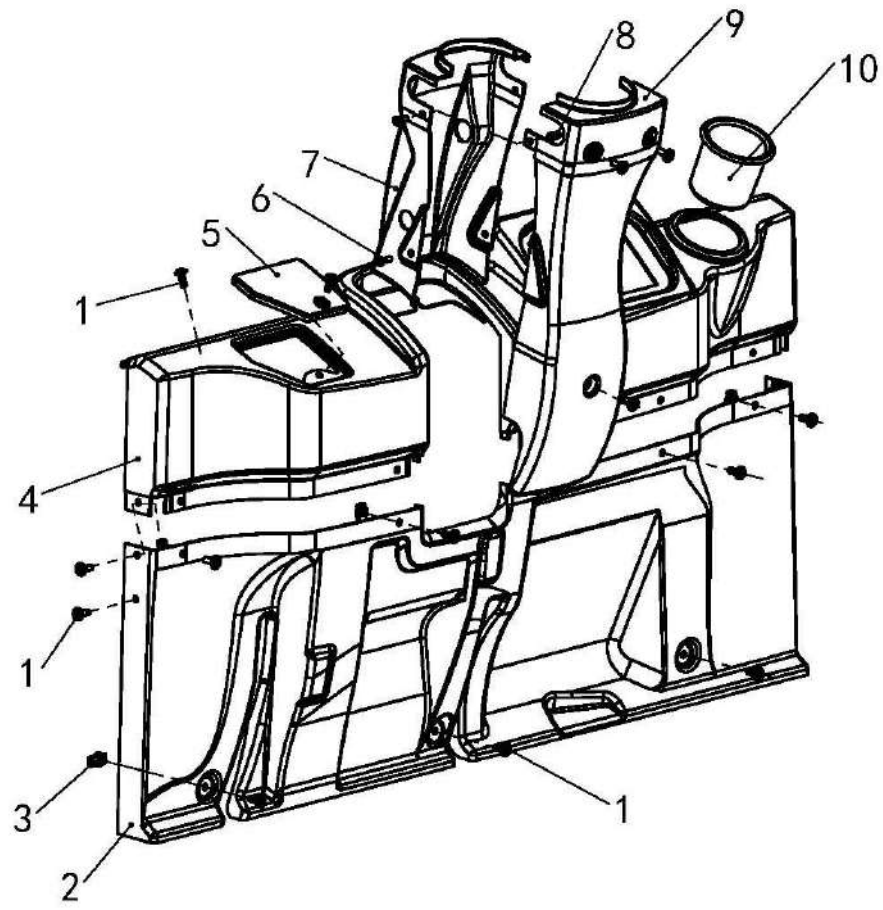

Fig. 17

Fig. 17 **Control panel**

No.	Coding	Description	Qty.	Note
1	941100100009	ScrewM6x12-8.8	19	
2	255010020002	Cover	1	
3	255010020009	Nut M6	10	
4	255010020001	Cover (Curtis)	1	
	255010020007	Cover (Inmotion)	1	Optional
5	255010020003	Lid	1	
6	910200500040	Screw GB818-M5x16-4.8	2	
7	255010020005	Front cover	1	
8	910301300001	NutGB17880.1-M5x14	1	
9	255010020006	Lid	1	
10	255010020004	Tool box	1	

Steering mechanism and installatio

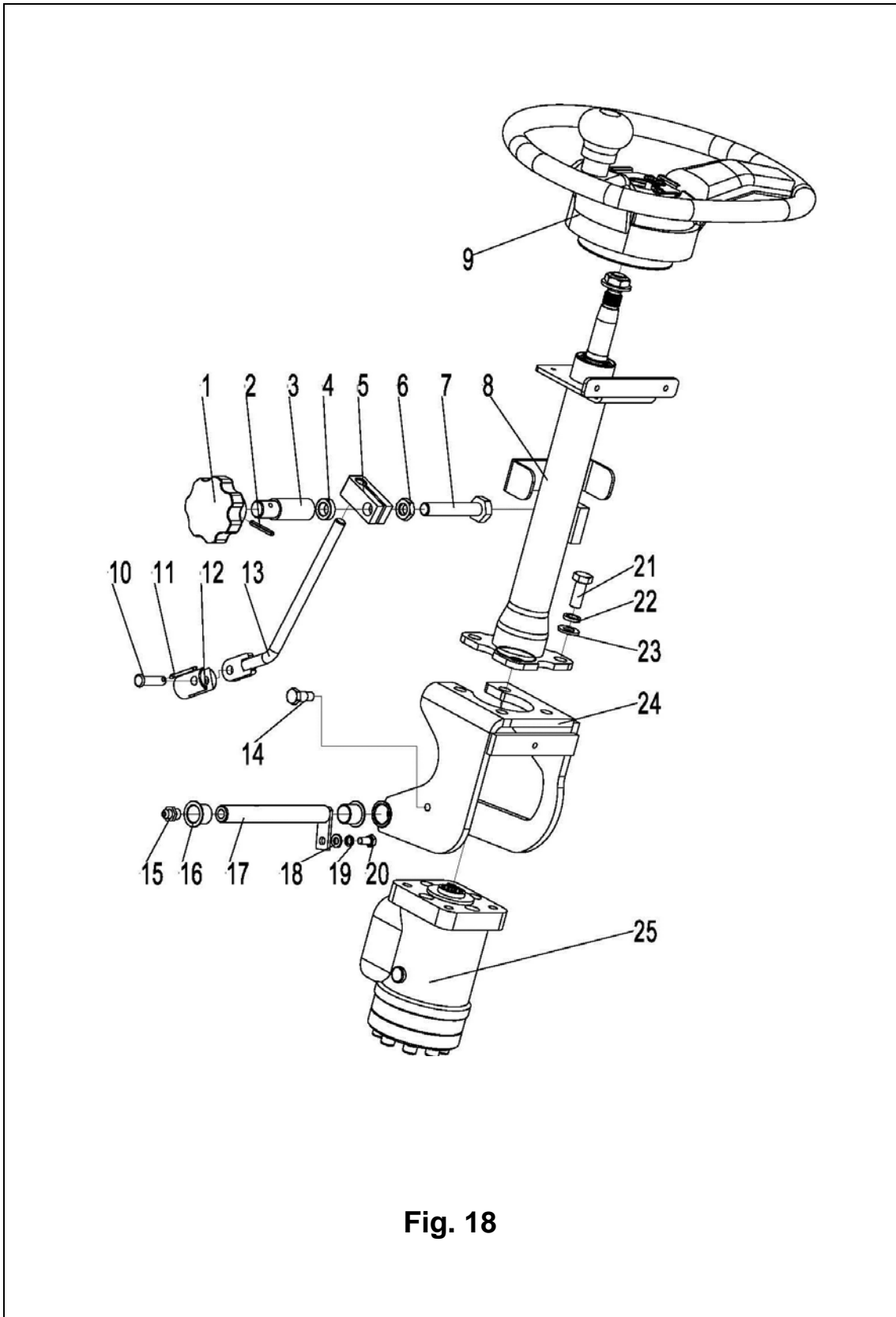

Fig. 18

Fig. 18 Steering mechanism and installation

No.	Coding	Description	Qty.	Note
1	911000300001	Handle GB7274.4-16x63	1	
2	910600400015	Dowel pin GB879.1-4x30	1	
3	253515020017	Bushing	1	
4	255015020018	Washer Φ 20x Φ 12x8	1	
5	255015020019	Latch segment	1	
6	910300300006	Nut GB6172.1-M12-05	1	
7	910100300057	Bolt GB5783-M12x70-8.8	1	
8	255015010001	Steering column	1	
9	255015010003	Steering wheel	1	
10	910600700014	Short axle GB882-6x26x1.6	1	
11	910600600005	Split pin GB91-1.6x10	1	
12	255015020002	Fixed seat	1	
13	255015010005	Adjustable lever	1	
14	255015020021	Screw	1	
15	911200100004	Grease nipple JB7940.1-M10x1	1	
16	940500200016	Bushing Φ 16x Φ 18x16-SF-1	2	
17	255011510003	Shaft Φ 16x135	1	
18	910400100005	Washer GB97.1-6-200HV	1	
19	910400500005	Washer GB93-6	1	
20	910100300009	Bolt GB5783-M6x12-8.8	1	
21	910100300036	Bolt GB5783-M10x25-8.8	4	
22	910400500007	Washer GB93-10	4	
23	910400100007	Washer GB97.1-10-200HV	4	
24	255015010004	Support welding	1	
25	254115010002	Steering gear BZZ5-E80BCF-H6	1	

Foot brake

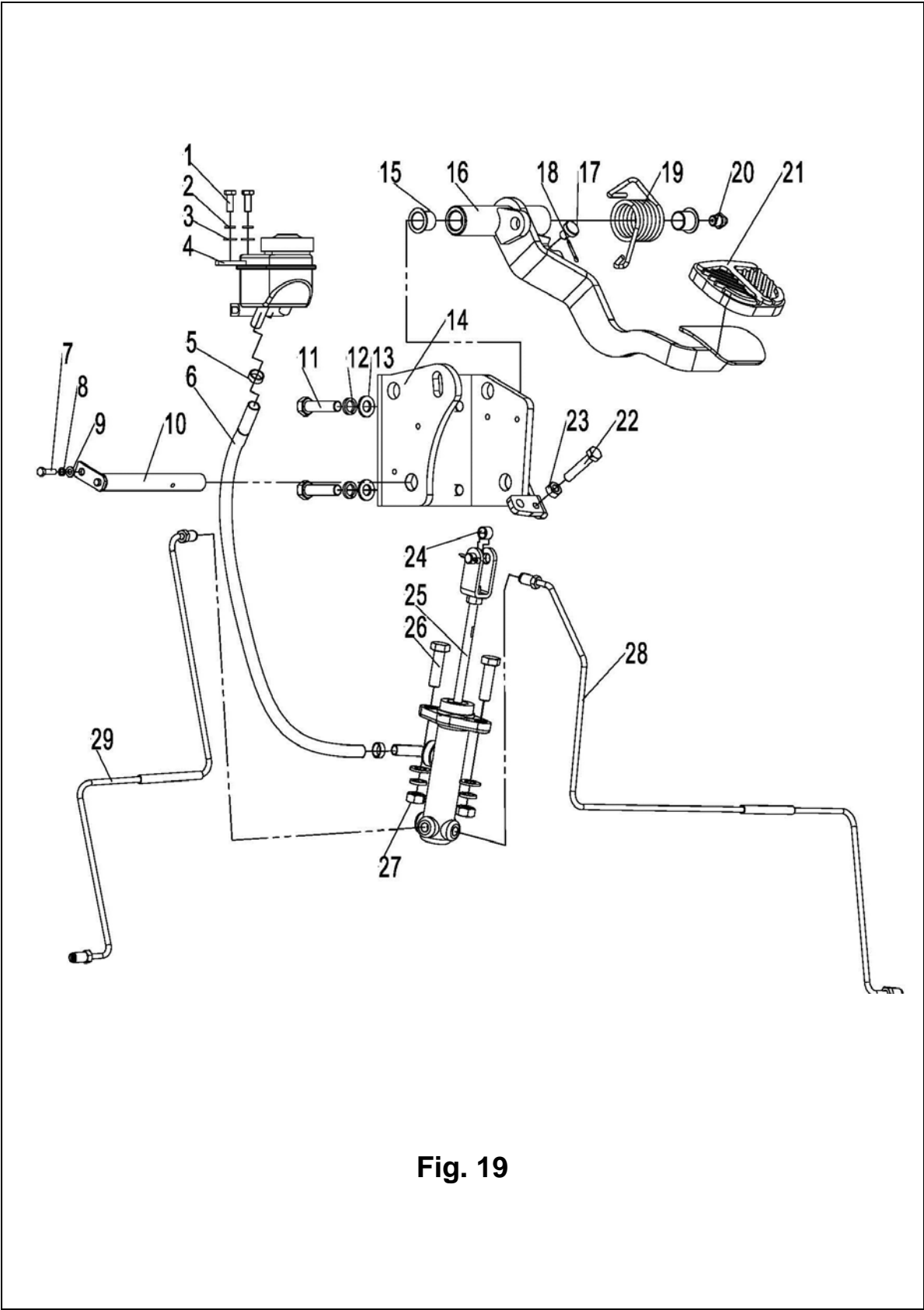

Fig. 19

Fig. 19**Foot brake**

No.	Coding	Description	Qty.	Note
1	910100300010	Bolt GB5783-M6x16-8.8	2	
2	910400500005	Washer GB93-6	2	
3	910400100005	Washer GB97.1-6-200HV	2	
4	255011510006	Grease nipple	1	
5	911000600001	Hose clamp QC/T390-(11-14)	2	
6	255011520021	Connecting pipe	1	
7	910100300003	Bolt GB5783-M5x12-8.8	1	
8	910400500004	Washer GB93-5	1	
9	910400100004	Washer GB97.1-5-200HV	1	
10	255011510003	Axle $\Phi 16 \times 135$	1	
11	910100300039	Bolt GB5783-M10x40-8.8	4	
12	910400500007	Washer GB93-10	6	
13	910400100007	Washer GB97.1-10-200HV	6	
14	255011510004	Foot brake holder welding	1	
15	940500100006	Bushing $\Phi 16 \times \Phi 18 \times 15$ -SF-1	2	
16	255011510002	Pedal weiding	1	
17	255011520010	Damping pad	1	
18	910600600015	Split pin GB91-2x20	1	
19	255011520008	Spring	1	
20	911200100004	Grease nipple JB7940.1-M10x1	1	
21	255011520013	Pedal (rubber)	1	
22	910100100023	Bolt GB5782-M8x45-8.8	1	
23	910300100006	Nut GB6170-M8-10	1	
24	940500100048	Bushing $\Phi 10 \times \Phi 12 \times 8$ -SF-1	1	
25	255011510001	Brake pump assembly	1	
26	910100300038	Bolt GB5783-M10x35-8.8	2	
27	910300100007	NutGB6170-M10-10	2	
28	255011510009	Hydraulic steel pipe welding 2	1	
29	255011510010	Hydraulic steel pipe welding 1	1	

Parking brake

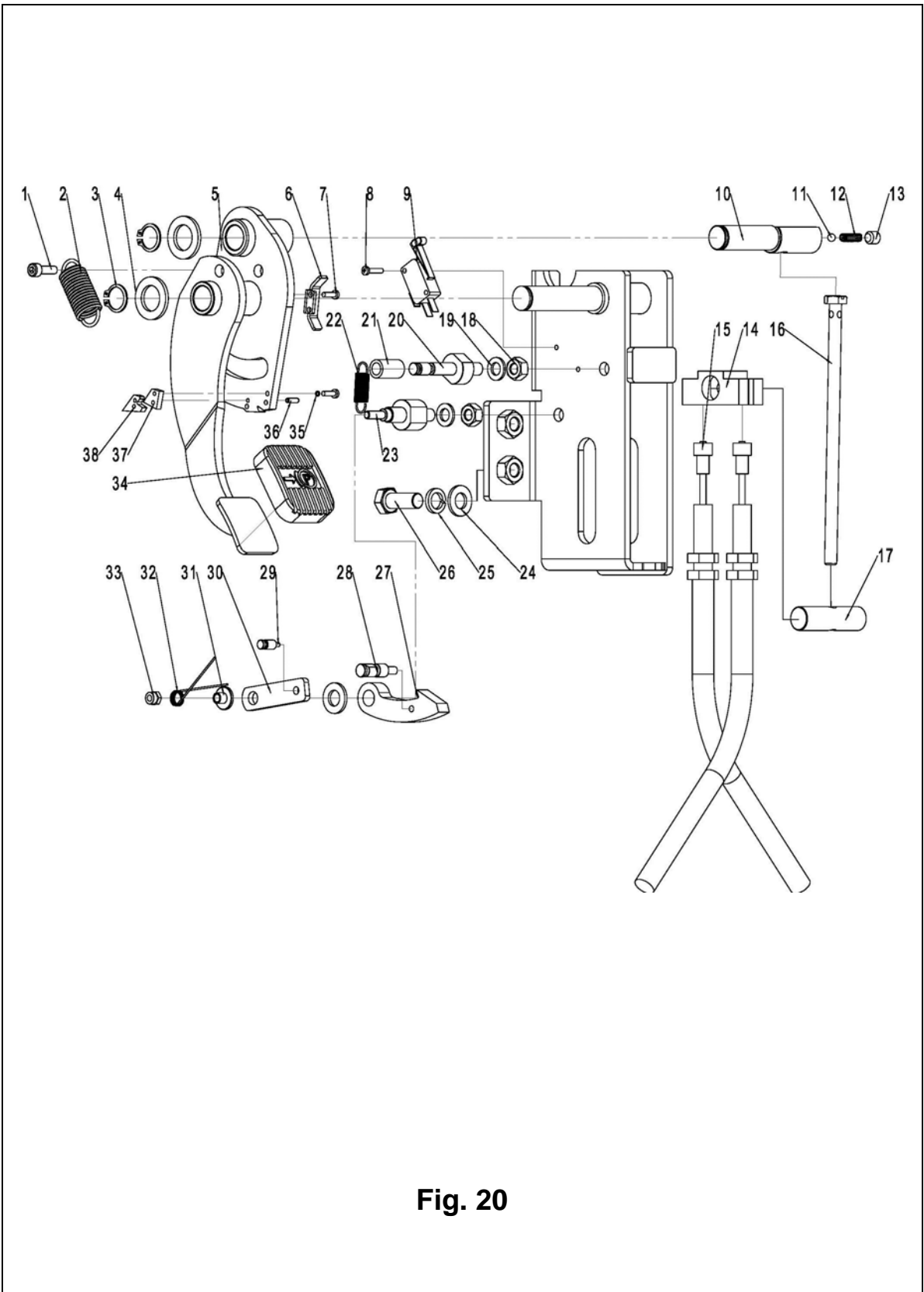

Fig. 20

Fig. 20 **Parking brake**

No.	Coding	Description	Qty.	Note
1	910200200023	Screw GB70.1-M5x16-8.8	1	
2	255012020016	Spring 2	1	
3	910401300007	Circlip GB894.1-16	2	
4	910400100010	Washer GB97.1-16-200HV	2	
5	255012010003	Pedal welding	1	
6	255012020035	Baffle	1	
7	910200500010	Screw GB818-M3x8-4.8	5	
8	910200500015	Screw GB818-M3x20-4.8	2	
9	920200300009	Micro switch RV-166-1C25	1	
10	255012020014	Shaft	1	
11	910701100003	Steel ball GB308-5.5	1	
12	255012020032	Spring	1	
13	910200800017	Screw GB77-M8x8-45H	1	
14	255012020028	Assembly seat	1	
15	284012010001	Hand brake wire rope	2	
16	255012020015	M8x170 Bolt	1	
17	255012020014	Axle	1	
18	910300100006	Nut GB6170-M8-10	2	
19	910400100006	Washer GB97.1-8-200HV	2	
20	255012020011	Axle 3	1	
21	255012020012	Polyurethane tube	1	
22	255012020017	Spring 1	1	
23	255012020008	Axle 4	1	
24	910400100007	Washer GB97.1-10-200HV	4	
25	910400500007	Washer GB93-10	3	
26	910100300036	Bolt GB5783-M10x25-8.8	3	
27	255012020001	Board 2	1	
28	255012020010	Axle 1	1	

Parking brake

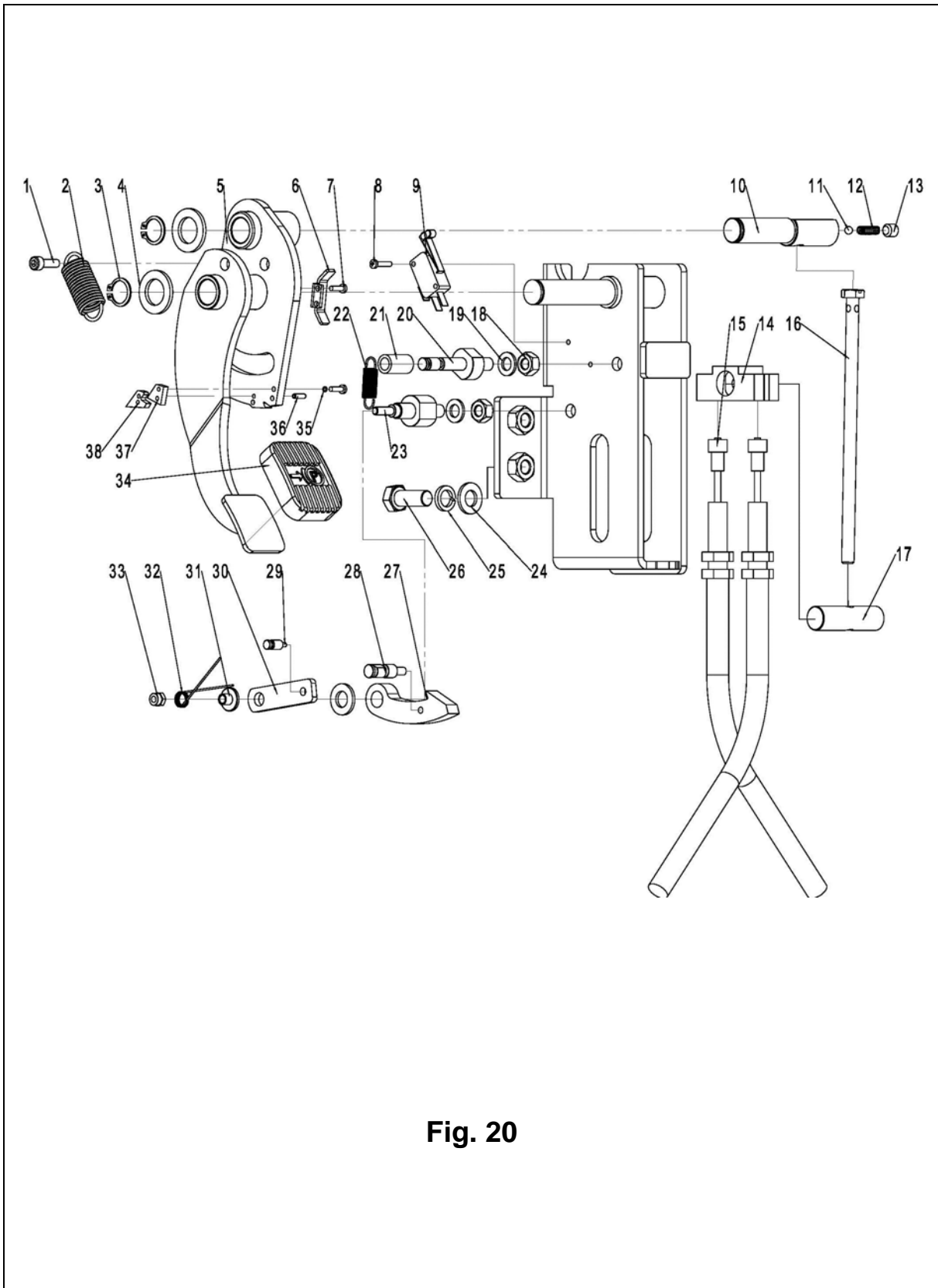

Fig. 20

Fig. 20**Parking brake**

No.	Coding	Description	Qty.	Note
29	255012020005	Axle 2	1	
30	255012020004	Board 1	1	
31	255012020003	Spring seat	1	
32	255012020018	Spring	1	
33	910300500002	Nut GB889.1-M5-10	1	
34	255012020034	Pedal pad	1	
35	910400500002	Washer GB93-3	3	
36	910600400053	Dowel pin GB879.1-2.5x10	1	
37	255012020001	Board 2	1	
38	255012020002	Board 3	1	

Overhead guard and installation

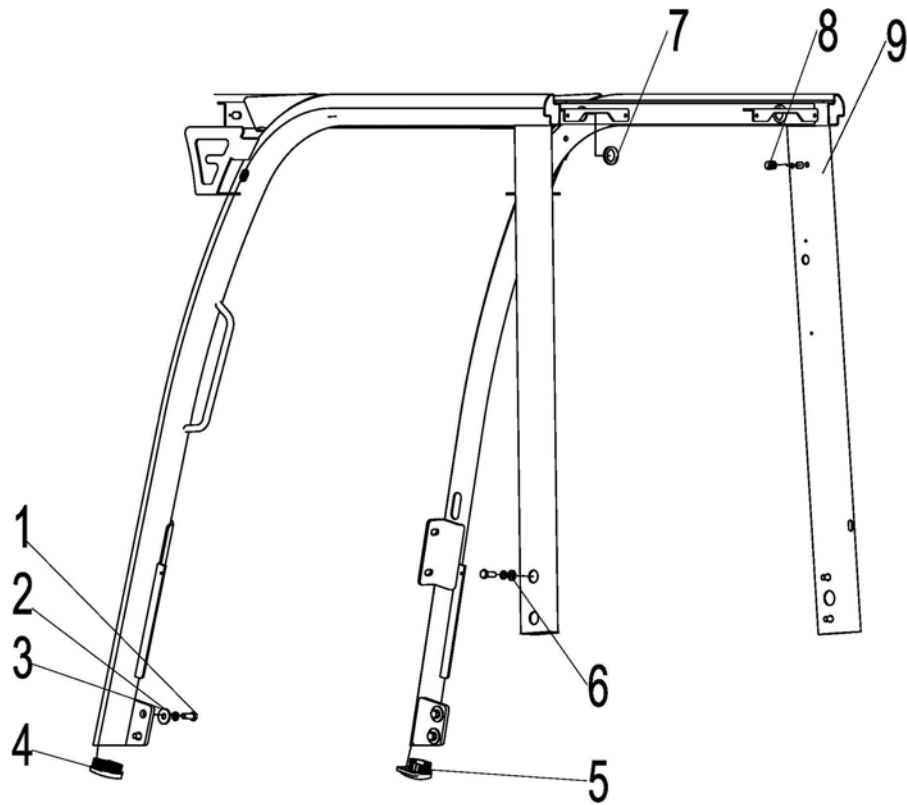

Fig. 21

Fig. 21 **Overhead guard and installation**

No.	Coding	Description	Qty.	Note
1	910100300050	Bolt GB5783-M12x30-8.8	8	
2	910400500008	Washer GB93-12	8	
3	910400100008	Washer GB97.1-12-200HV	4	
4	255022020002	Special pipe cover	1	
5	255022020001	Special pipe cover	1	
6	910400200005	Washer GB96.1-12-200HV	4	
7	255022020004	Coil	2	
8	255022020003	Coil	3	
9	254122010001	Overhead guard welding	1	

Rearview mirror installation

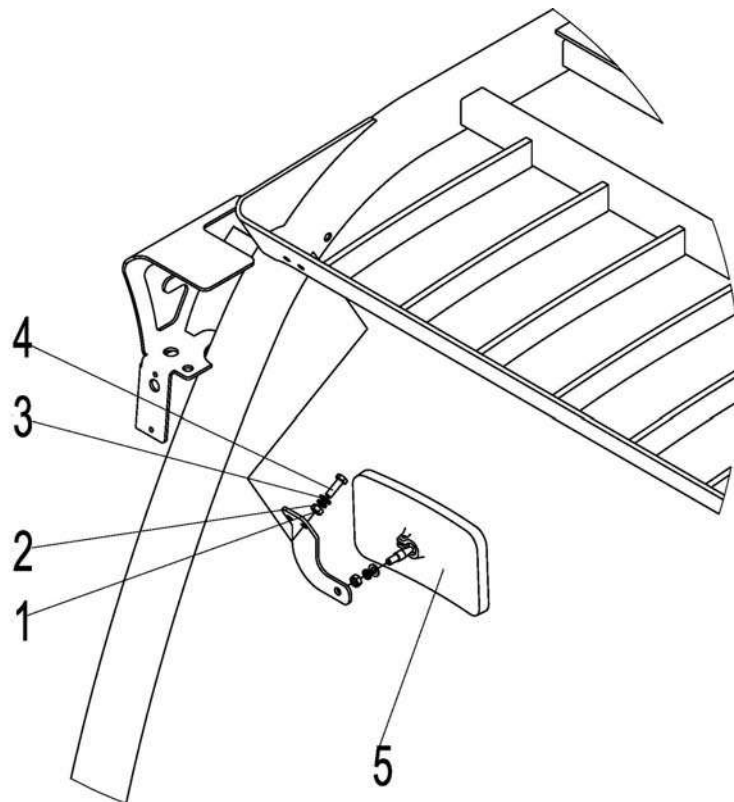

Fig. 22

Fig. 22 Rearview mirror installation

No.	Coding	Description	Qty.	Note
1	910300100006	Nut GB6170-M8-10	4	
2	910400500006	Washer GB93-8	4	
3	910400100006	Washer GB97.1-8-200HV	4	
4	910100300022	Bolt GB5783-M8x20-8.8	4	
5	272049510001	Rearview mirror	2	

Steering axle and installation

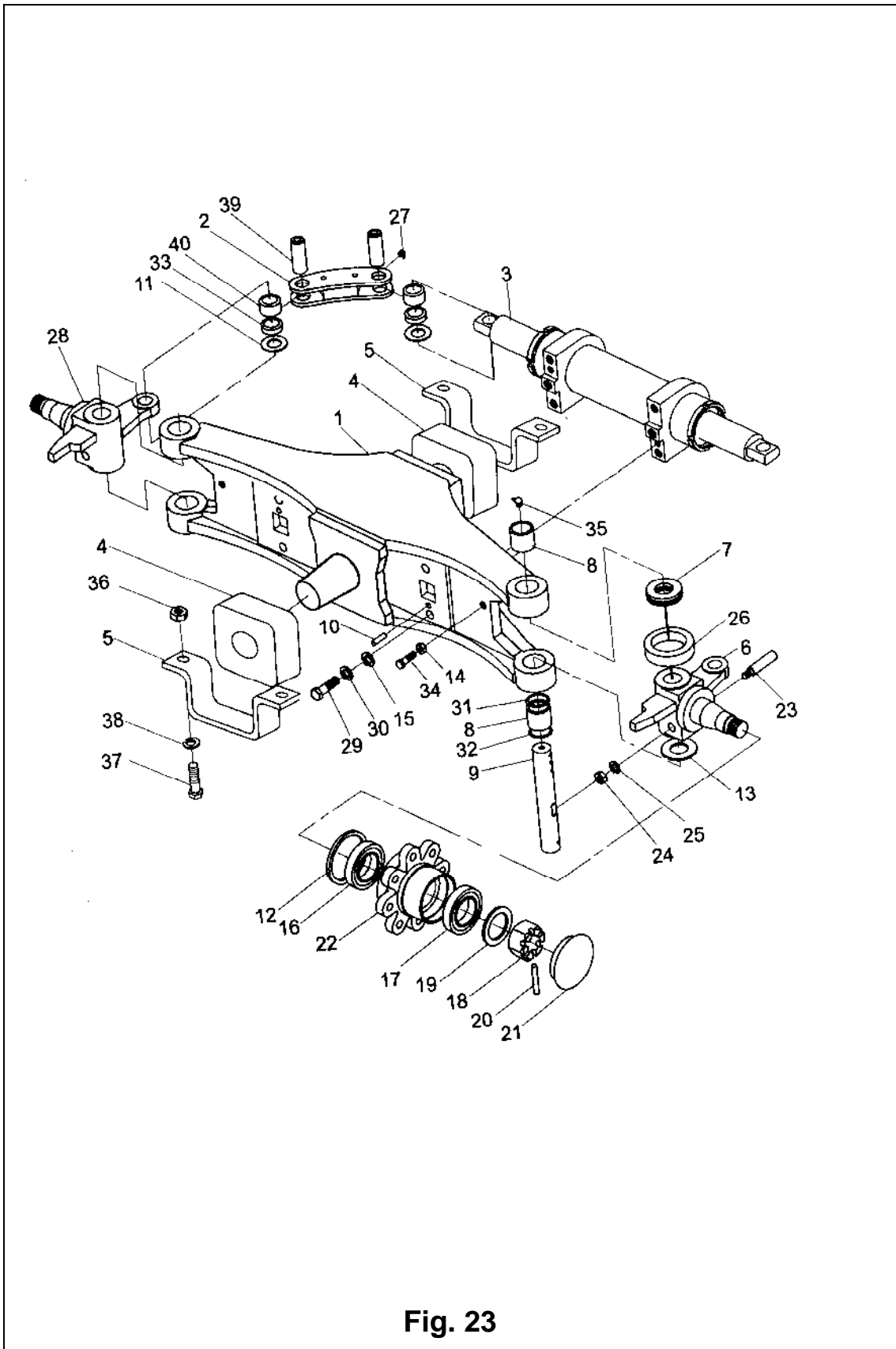

Fig. 23

Fig. 23 Steering axle and installation

No.	Coding	Description	Qty.	Note
A	254116010001	1.5T steering axle	1	
1	254198526001	Steering bridge assembly	1	
2	254198526002	Linking rod	2	
3	254198516003	Steering cylinder assembly	1	
4	253516020001	Anti vibration pad	2	
5	253516020002	Fixing plate	2	
6	254198526004	Left knuckle assembly	1	
7	254198526005	Bearing	2	
8	254198526006	Bearing 942/25	2	
9	254198526007	Pin	2	
10	254198526008	Dowel pin8x20	2	
11	254198526014	Washer	8	
12	254198526009	framework seal ring	2	
13	254198526010	Pad	4	
14	910300100007	Nut GB6170-M10-10	12	
15	910400100008	Washer GB97.1-12-200HV	4	
16	254198526011	Bearing 30208	2	
17	254198526012	Bearing 30206	2	
18	254198526013	Hexagonal groove nut M24x2	2	
19	910400100014	Washer GB97.1-24-200HV	2	
20	910600600038	Pin 5x45	2	
21	254198526015	Wheel hub cover	2	
22	254198526016	Steering wheel hub	2	
23	255098526017	Strict bolt	2	
24	910300100007	Nut GB6170-M10-10	2	
25	910400100007	Washer GB97.1-10-200HV	2	
26	254198526018	Bushing	2	
27	253098526019	Grease nipple	4	

Steering axle and installation

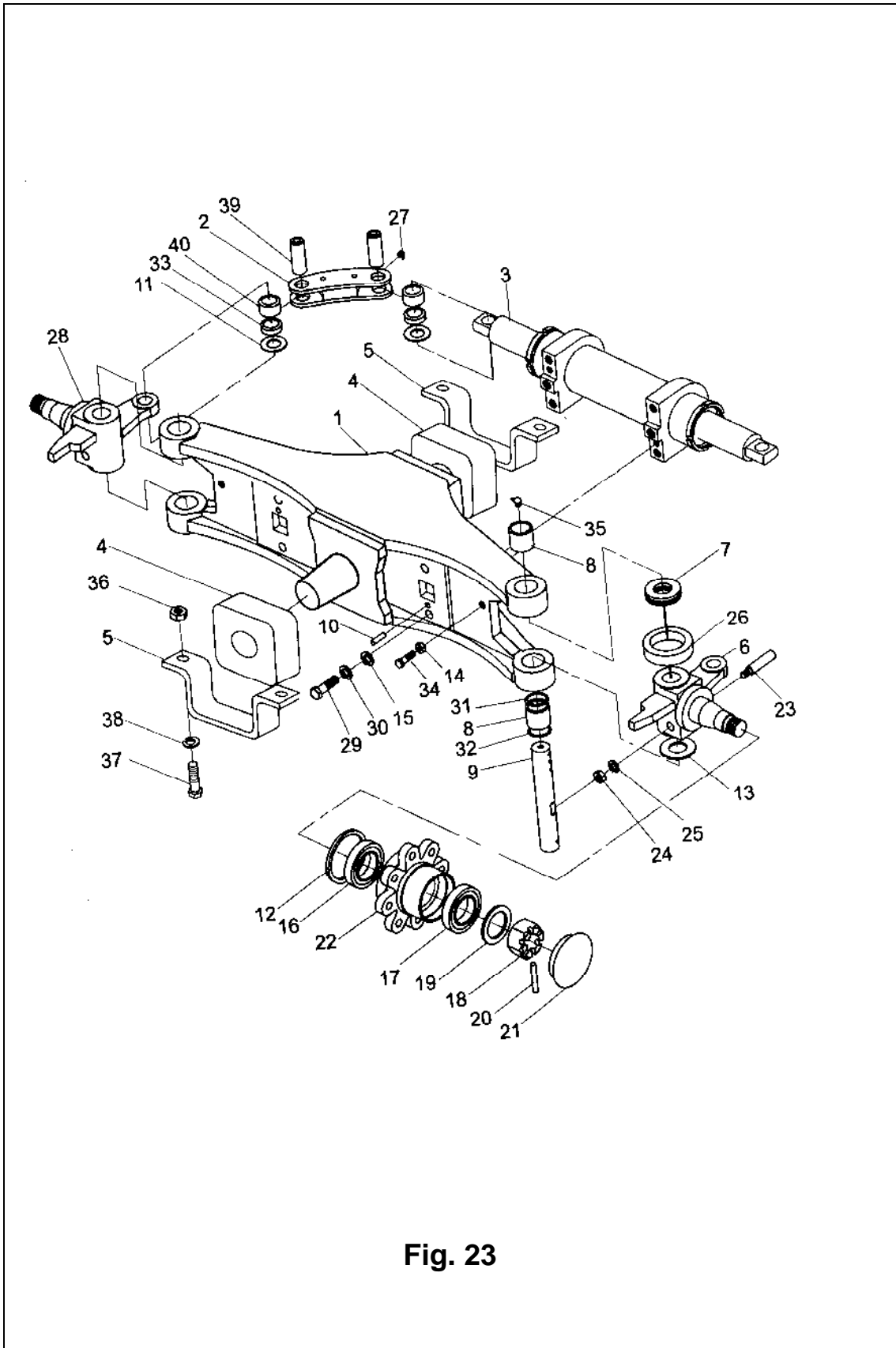

Fig. 23 Steering axle and installation

No.	Coding	Description	Qty.	Note
28	254198526020	Right knuckle assembly 1	1	
29	910100300052	Bolt M12x40	4	
30	910400500008	Washer GB93-12	4	
31	254198526022	O ring	2	
32	254198516023	Oil seal	4	
33	253098526024	Bushing $\Phi 26 \times \Phi 24 \times 6.5$	4	
34	910100300052	Bolt GB5783-M12x40-8.8	2	
35	253098526025	Grease nipple (90°)	2	
36	910300100010	Nut GB6170-M16-10	4	
37	910100300071	Bolt GB5783-M16x45-8.8	4	
38	910400500010	Washer GB93-16	4	
39	254198526026	Linking pin	4	
40	254198526027	Joint bearing GE1515ES	4	

Steering cylinder

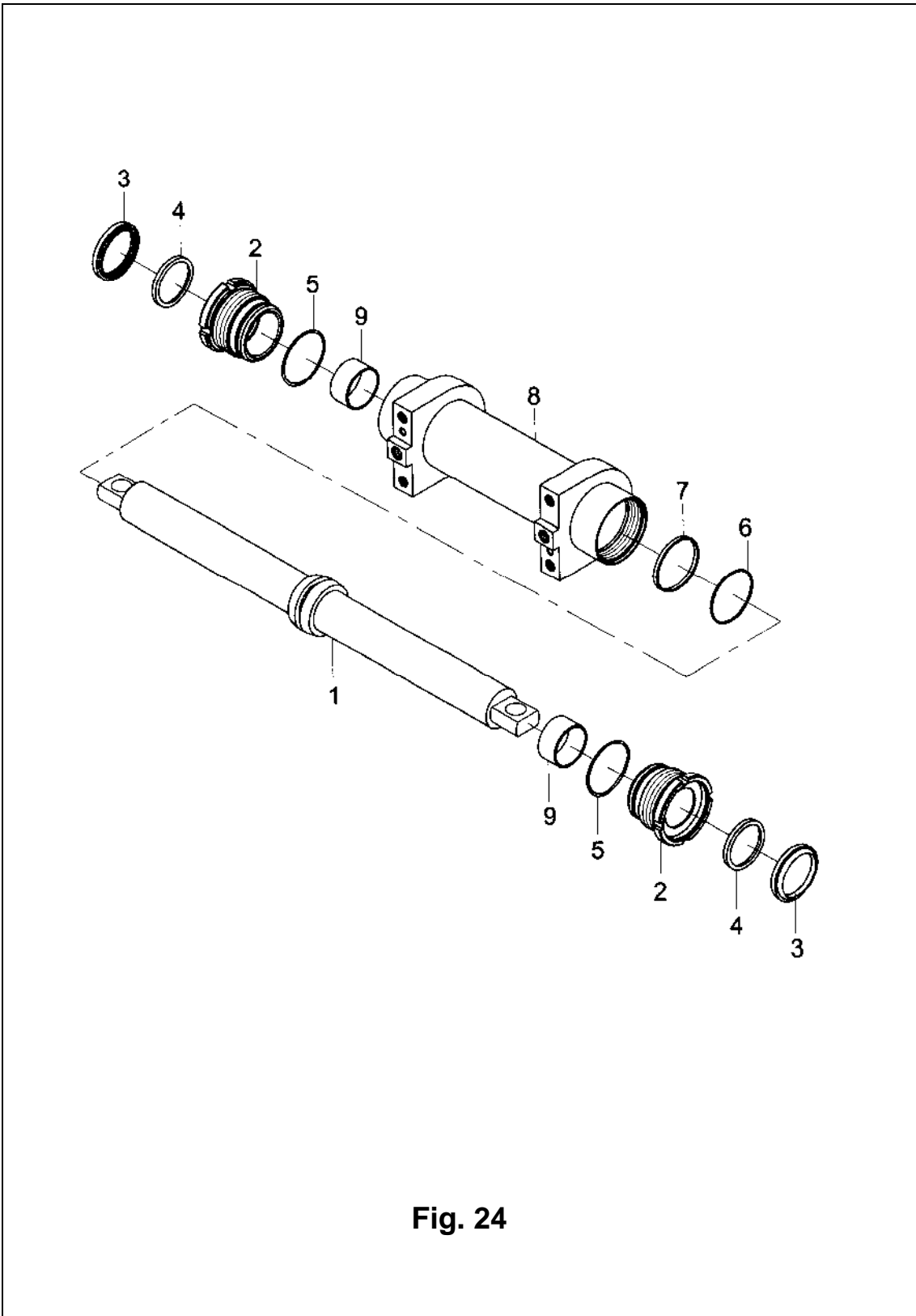

Fig. 24

Fig. 24 **Steering cylinder**

No.	Coding	Description	Qty.	Note
A	254198516003	Steering cylinder	1	FE4P16-18N
B	254198516028	Sealing part maintenance package (steering cylinder)	1	Including 3.4.5.6.7
1		Piston rod assembly	1	▲
2		Cylinder cover	2	▲
3		Dust ring DH40	2	▲
4		U ringUN40	2	▲
5		O ring53×3.55	2	▲
6		O ring50×3.55	1	▲
7		Support ring	1	▲
8		Cylinder assembly	1	▲
9		Bearing	2	▲

Note: Spare parts will not be provided seperately

Steering wheel assembly

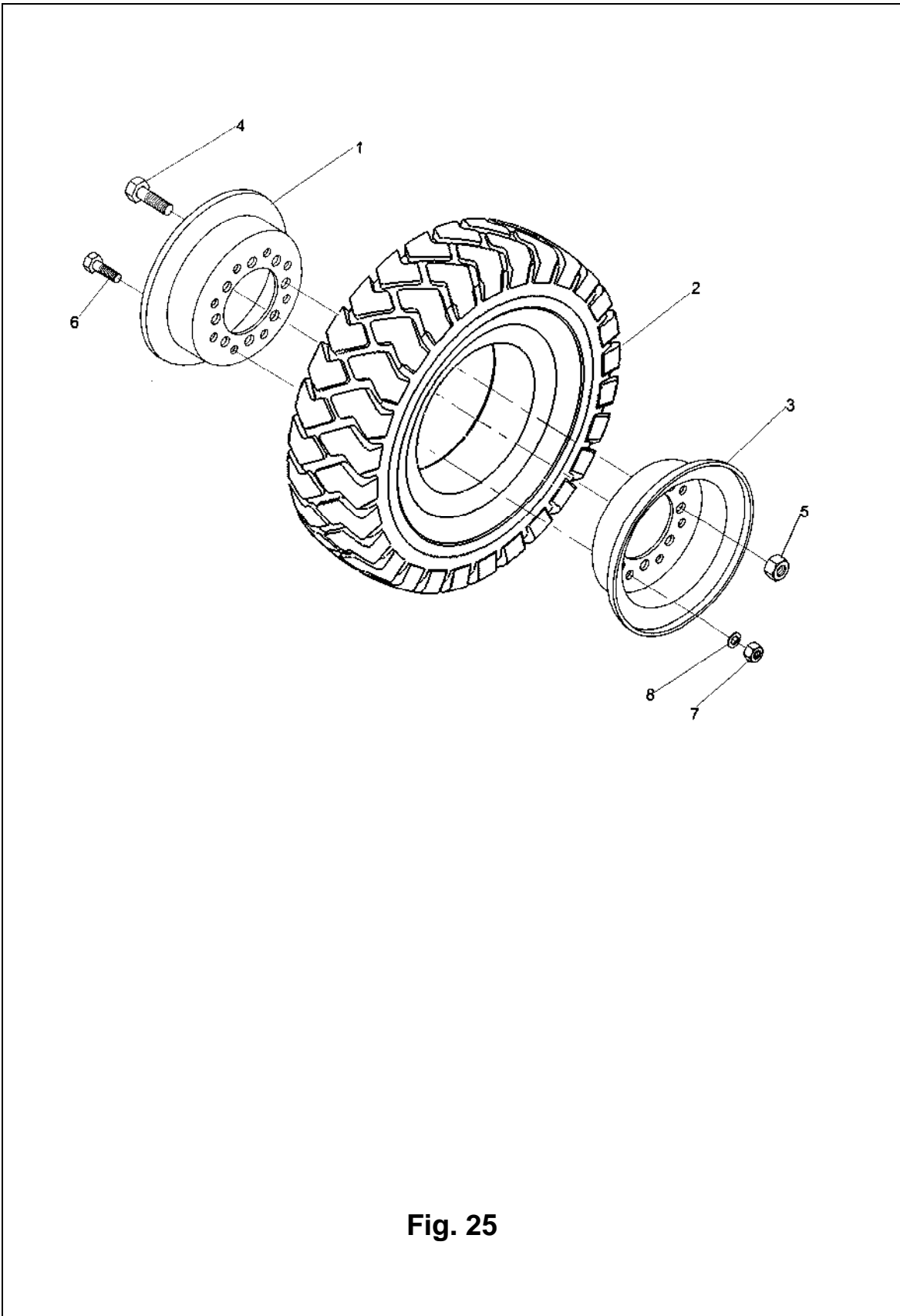

Fig. 25

Fig. 25 Steering wheel assembly

No.	Coding	Description	Qty.	Note
A	251015510001	Steering wheel assembly 5.00-8-10PR(pneumatic, Chaoyang)	2	Including 1.2.3.6.7.8
	251015510006	Steering wheel assembly 5.00-8(solid, Chaoyang)	2	
	251015510007	Steering wheel assembly 5.00-8(environment protection, Chaoyang)	2	
1	251015520002	Inner rim3.00D-8	2	
2	251015510001	Tyre (pneumatic)5.00-8-10PR	2	
	251015510003	Tyre (solid)5.00-8	2	Optional
	251015510004	Tyre(environment protection)5.00-8	2	Optional
3	251015520001	Inner rim 3.00D-8	2	
4	253098526040	Rim Bolt	12	Steering wheel hub
5	253098526041	Rim Nut(M14X1.5)	12	Steering wheel hub
6	252013020001	Rim BoltM12x26	12	
7	910300100008	Nut GB6170-M12-10	12	
8	910400500008	Washer GB93-12	12	

Working cylinder mechanism and installation

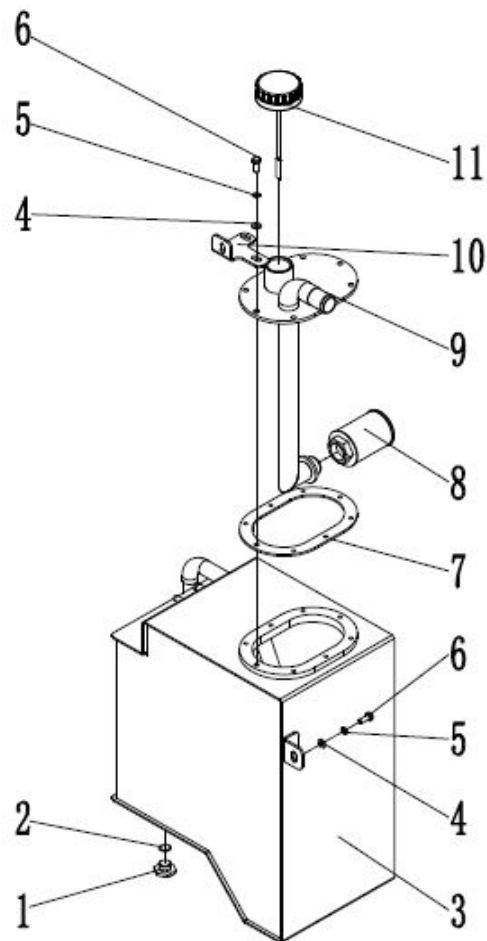

Fig. 26

Fig. 26 Working cylinder mechanism and installation

No.	Coding	Description	Qty.	Note
1	253519020001	Drain plug M20x1.5	1	
2	910800900001	Washer JB982-20	1	
3	255019010001	Cylinder welding	1	
4	910400100006	Washer GB97.1-8-200HV	10	
5	910400500006	Washer GB93-8	10	
6	910100300022	Bolt GB5783-M8x20-8.8	10	
7	253519020010	Sealing gasket	1	
8	251019010003	Screen filter WU63×100	1	
9	255019010002	Cover plate welding	1	
10	255019020012	Fixing plate 2	1	
11	255019010003	Oil dipstick assembly	1	

Multiple directional control valve (bigeminy)

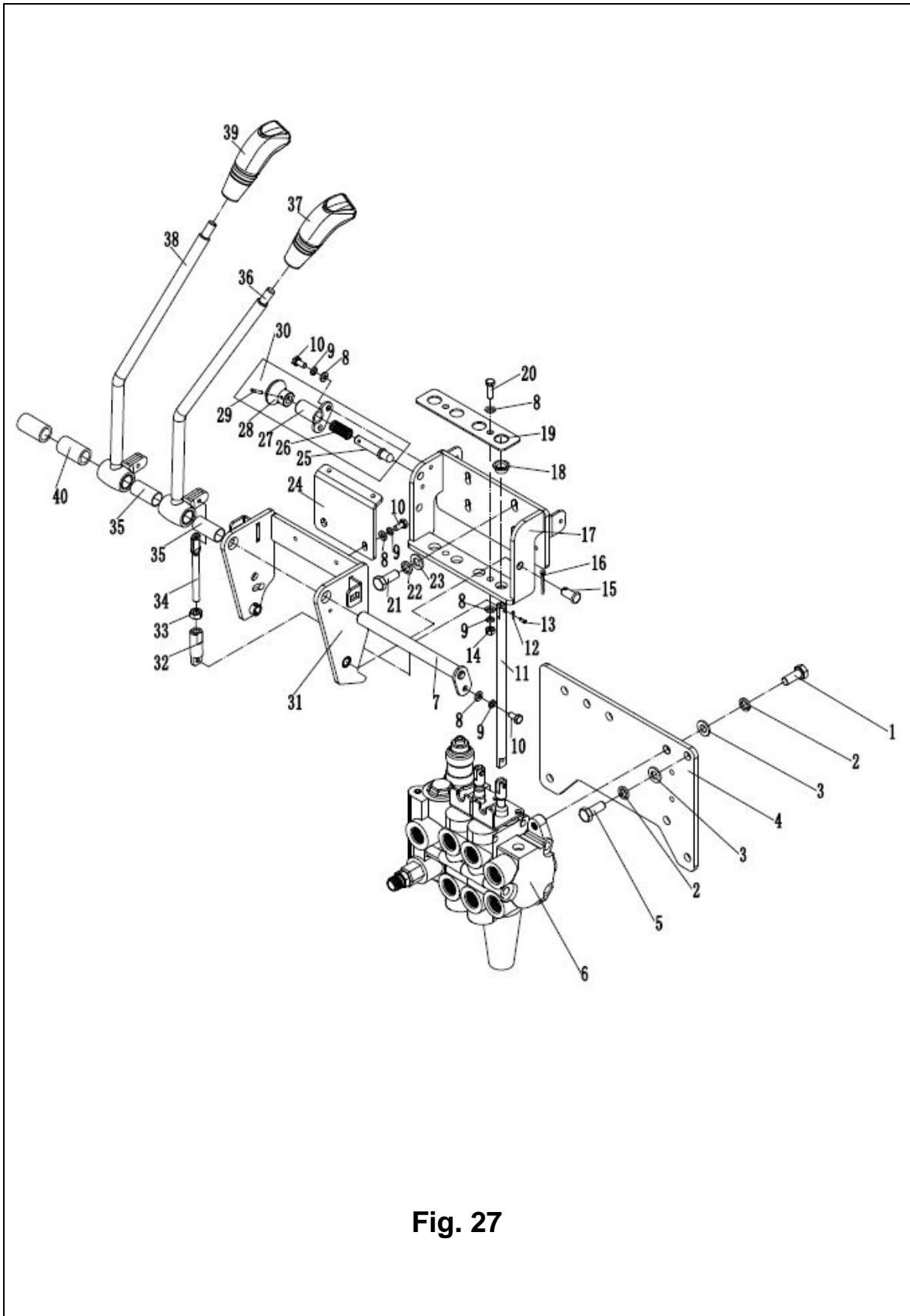

Fig. 27

Fig. 27 Multiple directional control valve (bigeminy)

No.	Coding	Description	Qty.	Note
1	910100400003	Bolt GB5786-M10x1.25x25-8.8	3	
2	910400500007	Washer GB93-10	6	
3	910400100007	Washer GB97.1-10-200HV	6	
4	255024520024	Supporting plate	1	
5	910100300036	Bolt GB5783-M10x25-8.8	3	
6	255025510002	Multi way valve (four combined)	1	
7	253524510004	Axle ϕ 16x168	1	
8	910400100005	Washer GB97.1-6-200HV	9	
9	910400500005	Washer GB93-6	7	
10	910100300009	Bolt GB5783-M6x12-8.8	5	
11	255024520018	Transition rod	3	
12	910600600026	Split pin GB91-3.2x20	6	
13	910600700032	Short axle GB882-10x20c1B	6	
14	910300100005	Nut GB6170-M6-10	2	
15	910600600026	Split pin GB91-3.2x20	2	
16	910600700032	Short axle GB882-10x20c1B	2	
17	255024510002	Fixed seat	1	
18	940500200022	Bushing ϕ 12x ϕ 14x20-SF-1	2	
19	255024520016	Pressing plate	1	
20	910100300011	Bolt GB5783-M6x20-8.8	2	
21	910100300023	Bolt GB5783-M8x25-8.8	4	
22	910400500006	Washer GB93-8	4	
23	910400100006	Washer GB97.1-8-200HV	4	
24	255024520001	Fixing plate	1	
25	255024520014	Axle ϕ 10x60	1	
26	255024520013	Spring	1	
27	255024510003	Axle ϕ 18x27.5	1	
28	255024520015	Handle	1	
29	910600400004	Dowel pin GB879.1-3x16	1	

Multiple directional control valve (bigeminy)

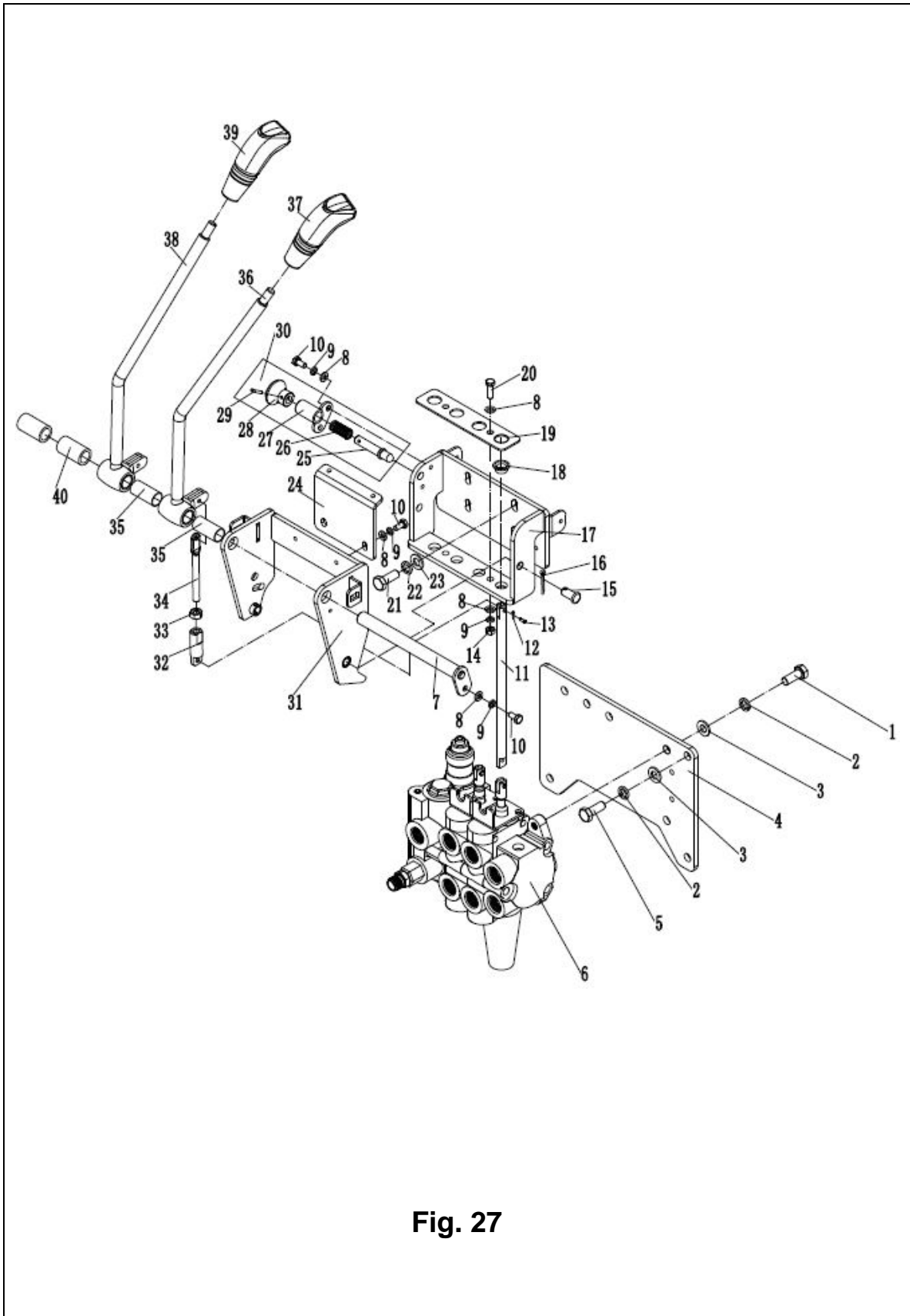

Fig. 27

Fig. 27 Multiple directional control valve (bigeminy)

No.	Coding	Description	Qty.	Note
30	255024510006	Handle assembly	1	
31	255024510001	Holder welding	1	
32	250525020008	Joint	2	
33	910300100006	NutGB6170-M8-10	2	
34	255024520017	Connecting rod	2	
35	255024520025	Bearing bushing φ18xφ16x37	2	
36	255024510004	Control lever welding (lifting)	1	
37	255024520022	Handle ball (lifting)	1	
38	255024510005	Control lever welding (slope)	1	
39	255024520023	Handle ball (slope)	1	
40	253524520005	Sleeve	2	

Multiple directional control valve (trigeminy)

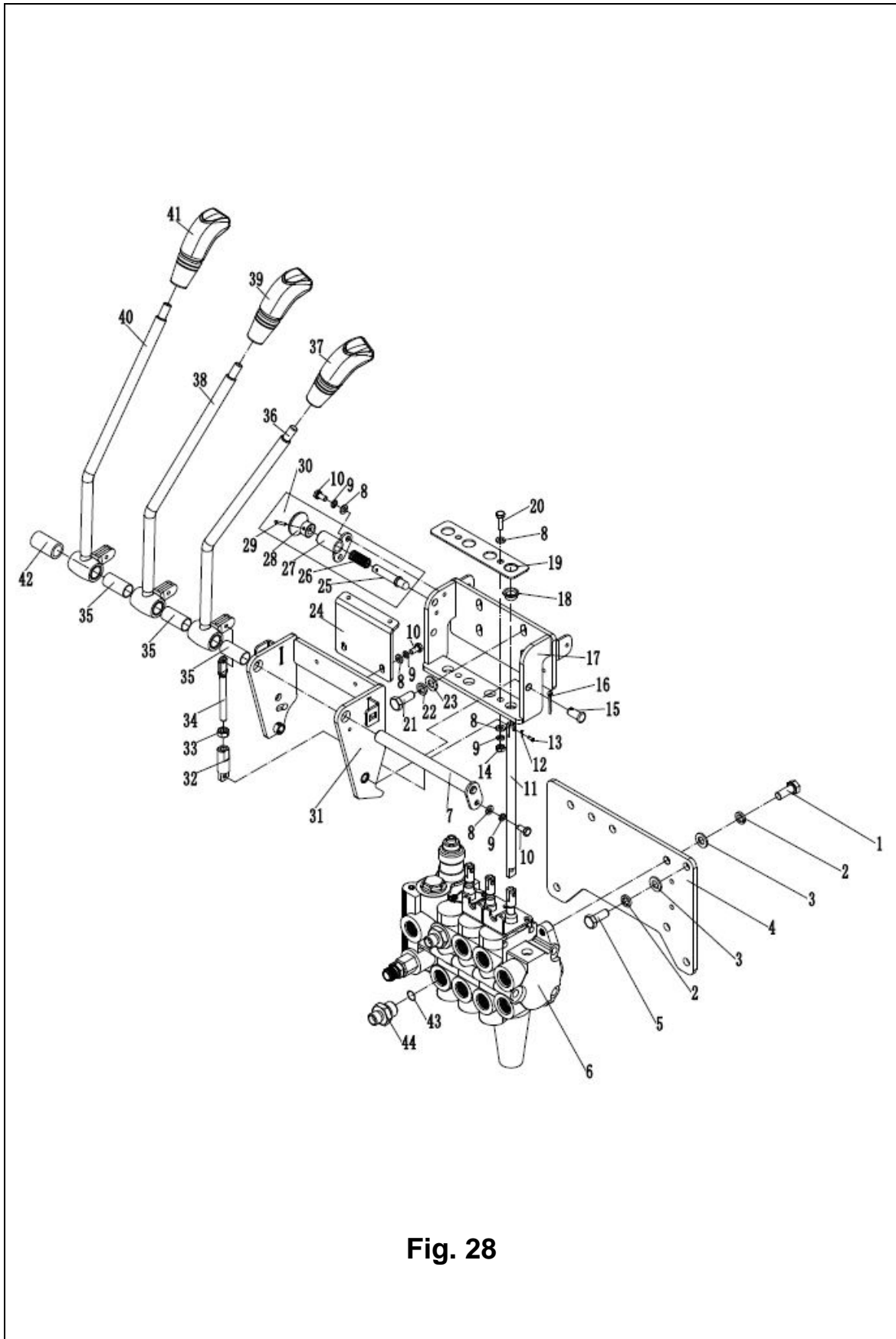

Fig. 28

Fig. 28 Multiple directional control valve (trigeminy)

No.	Coding	Description	Qty.	Note
1	910100400003	Bolt GB5786-M10x1.25x25-8.8	3	
2	910400500007	Washer GB93-10	6	
3	910400100007	Washer GB97.1-10-200HV	6	
4	255024520024	Supporting plate	1	
5	910100300036	Bolt GB5783-M10x25-8.8	3	
6	255025510002	Multi way valve (four combined)	1	
7	253524510004	Axle ϕ 16x168	1	
8	910400100005	Washer GB97.1-6-200HV	9	
9	910400500005	Washer GB93-6	7	
10	910100300009	Bolt GB5783-M6x12-8.8	5	
11	255024520018	Transition rod	3	
12	910600600026	Split pin GB91-3.2x20	9	
13	910600700032	Short axle GB882-10x20c1B	9	
14	910300100005	Nut GB6170-M6-10	2	
15	910600600026	Split pin GB91-3.2x20	2	
16	910600700032	Short axleGB882-10x20c1B	2	
17	255024510002	Fixing seat	1	
18	940500200022	Bushing ϕ 12x ϕ 14x20-SF-1	3	
19	255024520016	Pressing plate	1	
20	910100300011	Bolt GB5783-M6x20-8.8	2	
21	910100300023	Bolt GB5783-M8x25-8.8	4	
22	910400500006	Washer GB93-8	4	
23	910400100006	Washer GB97.1-8-200HV	4	
24	255024520001	Fixing plate	1	
25	255024520014	Axle ϕ 10x60	1	
26	255024520013	Spring	1	
27	255024510003	Axle ϕ 18x27.5	1	
28	255024520015	Handle	1	
29	910600400004	Dowel pin GB879.1-3x16	1	

Multiple directional control valve (trigeminy)

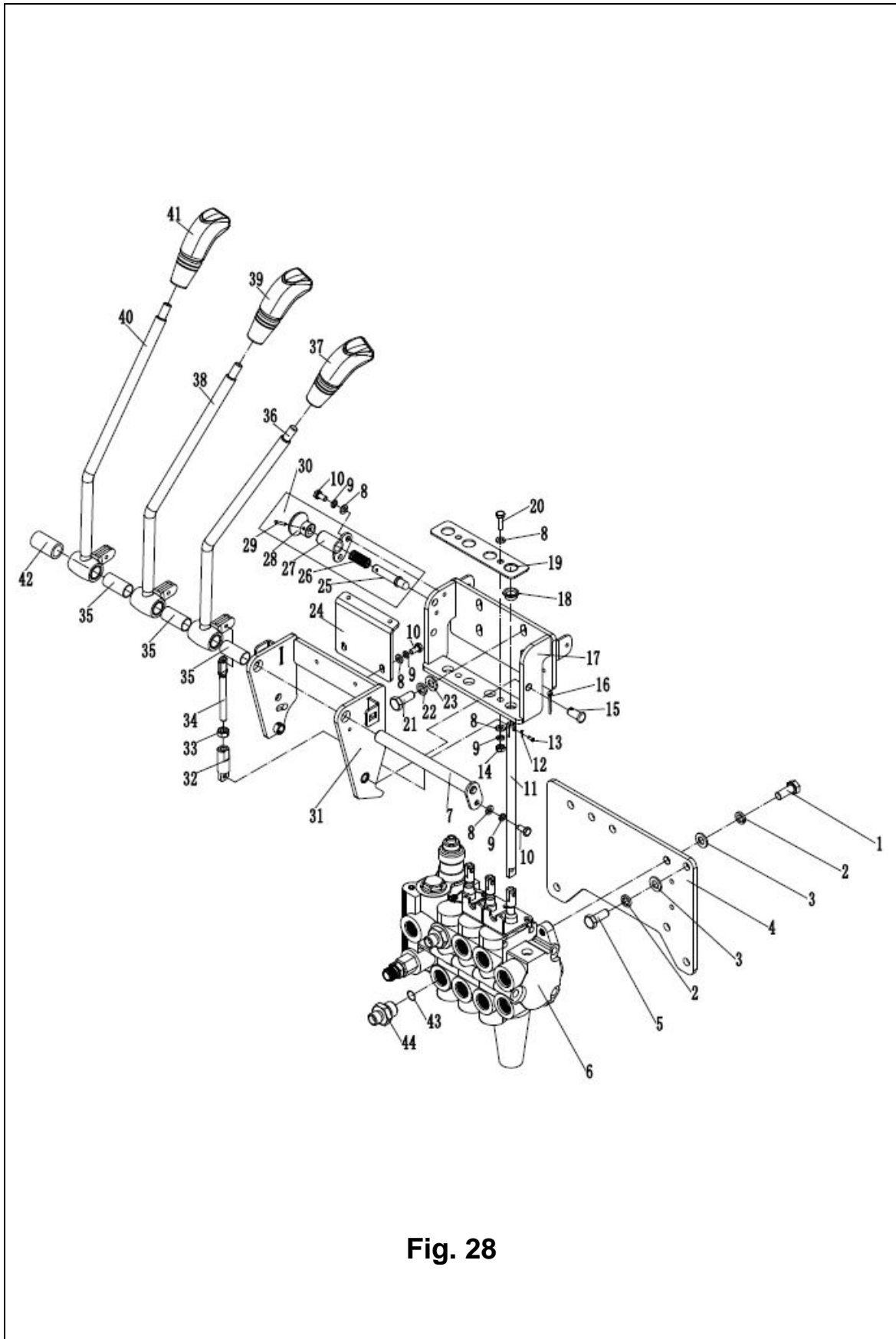

Fig. 28

Fig. 28 Multiple directional control valve (trigeminy)

No.	Coding	Description	Qty.	Note
30	255024510006	Handle assembly	1	
31	255024510001	Frame welding	1	
32	250525020008	Joint	3	
33	910300100006	Nut GB6170-M8-10	3	
34	255024520017	Linking rod	3	
35	255024520025	Bearing $\phi 18 \times \phi 16 \times 37$	3	
36	255024510004	Control lever welding (lifting)	1	
37	255024520022	Handle ball (lifting)	1	
38	255024510005	Control lever welding (slope)	1	
39	255024520023	Handle ball(slope)	1	
40	255025010001	Control lever welding (accessory 1)	1	
41	255025020002	Handle ball (accessory 1)	1	
42	253524520005	Sleeve	1	
43	910800100003	O ring 17x2.65	2	
44	253523520006	Joint8-M20x1.5-M16x1.5-60°	2	

Multiple directional control valve(four joint)

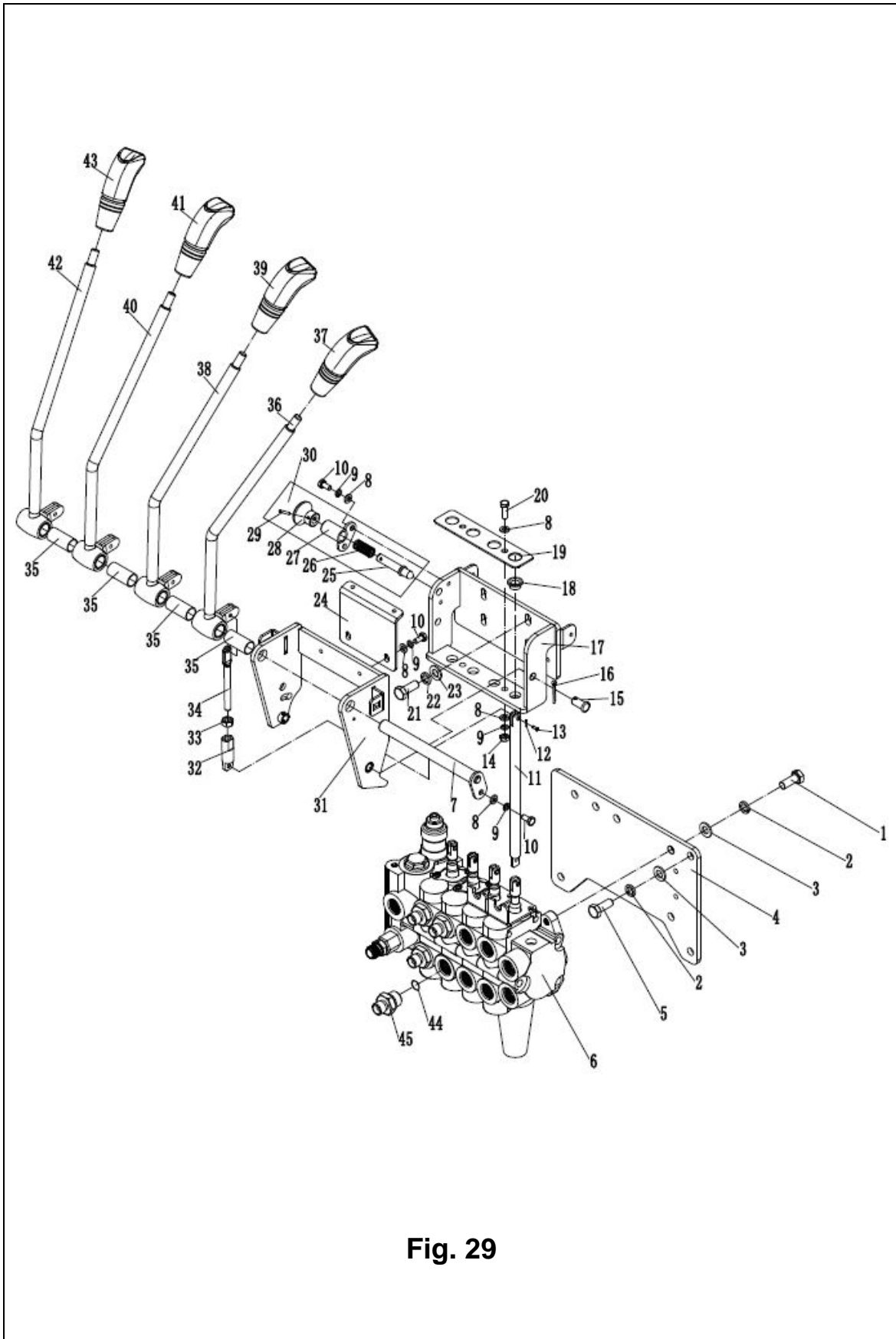

Fig. 29

Fig. 29 Multiple directional control valve(four joint)

No.	Coding	Description	Qty.	Note
1	910100400003	Bolt GB5786-M10x1.25x25-8.8	3	
2	910400500007	Washer GB93-10	6	
3	910400100007	Washer GB97.1-10-200HV	6	
4	255024520024	Supporting plate	1	
5	910100300036	Bolt GB5783-M10x25-8.8	3	
6	255025510002	Multi way valve (four combined)	1	
7	253524510004	Axle ϕ 16x168	1	
8	910400100005	Washer GB97.1-6-200HV	9	
9	910400500005	Washer GB93-6	7	
10	910100300009	Bolt GB5783-M6x12-8.8	5	
11	255024520018	Transition rod	4	
12	910600600026	split pin GB91-3.2x20	12	
13	910600700032	Short axle GB882-10x20c1B	12	
14	910300100005	Nut GB6170-M6-10	2	
15	910600600026	split pin GB91-3.2x20	2	
16	910600700032	Short axle GB882-10x20c1B	2	
17	255024510002	Fixing seat	1	
18	940500200022	Bushing ϕ 12x ϕ 14x20-SF-1	4	
19	255024520016	Pressing plate	1	
20	910100300011	Bolt GB5783-M6x20-8.8	2	
21	910100300023	Bolt GB5783-M8x25-8.8	4	
22	910400500006	Washer GB93-8	4	
23	910400100006	Washer GB97.1-8-200HV	4	
24	255024520001	Fixing plate	1	
25	255024520014	Axle ϕ 10x60	1	
26	255024520013	Spring	1	
27	255024510003	Axle ϕ 18x27.5	1	
28	255024520015	Handle	1	
29	910600400004	Dowel pin GB879.1-3x16	1	

Multiple directional control valve(four joint)

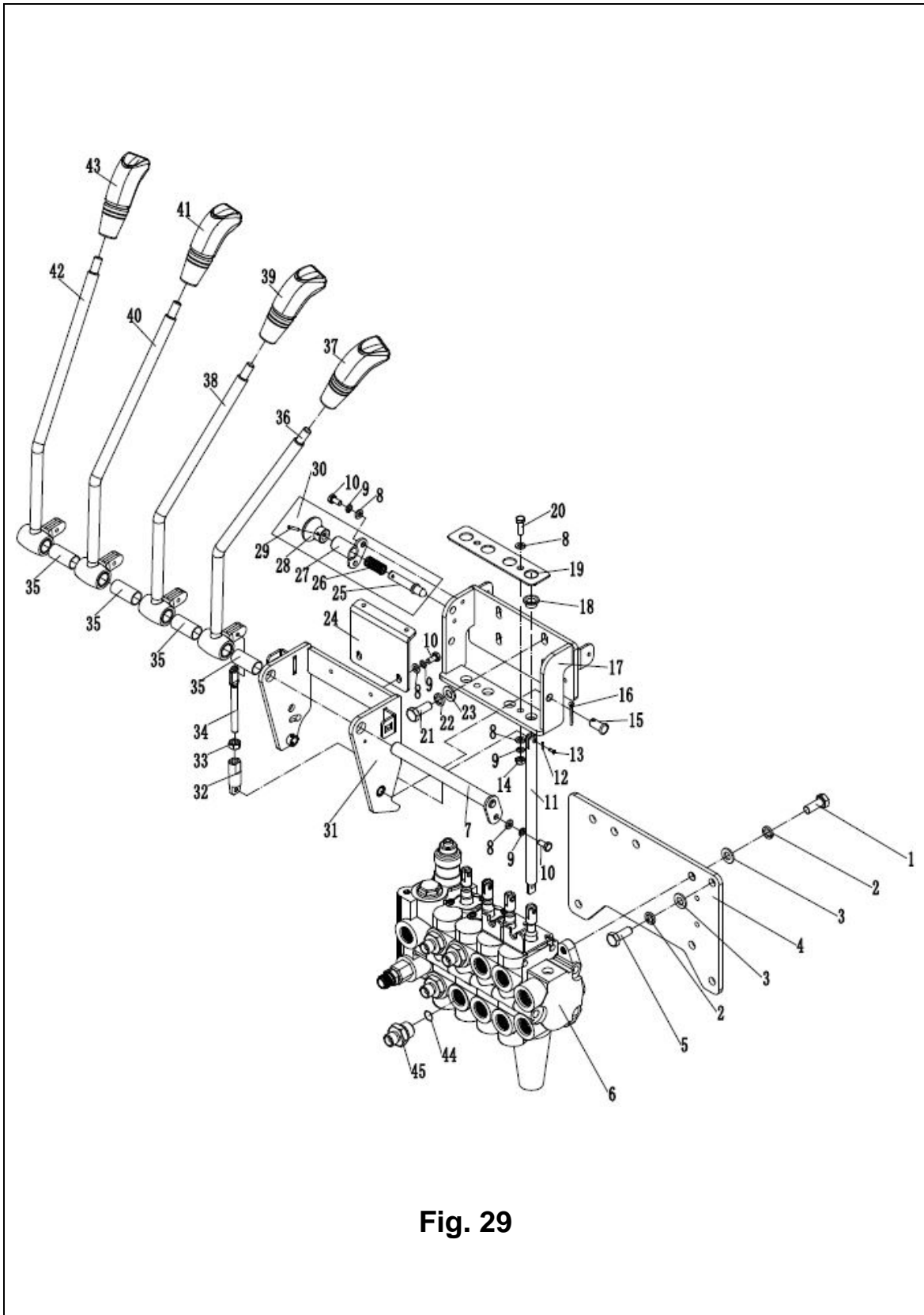

Fig. 29

Fig. 29 Multiple directional control valve(four joint)

No.	Coding	Description	Qty.	Note
30	255024510006	Handle assembly	1	
31	255024510001	Frame assembly	1	
32	250525020008	Joint	4	
33	910300100006	Nut GB6170-M8-10	4	
34	255024520017	Connecting rod	4	
35	255024520025	Bearing bushing $\phi 18 \times \phi 16 \times 37$	4	
36	255024510004	Control lever welding(lifting)	1	
37	255024520022	Handle ball(lifting)	1	
38	255024510005	Control lever welding(slope)	1	
39	255024520023	Handle ball (slope)	1	
40	255025010001	Control lever welding(accessory 1)	1	
41	255025020002	Handle ball(accessory 1)		
42	255025510001	Control lever welding (accessory 2)	1	
43	255025520002	Handle ball (accessory 2)	1	
44	910800100003	Oring 17x2.65	4	
45	253523520006	Joint 8-M20x1.5-M16x1.5-60°	4	

Fig. 30**Hydraulic system**

No.	Coding	Description	Qty.	Note
1	255023510005	Joint 25-G1-φ32	1	
2	911000600006	Hose clamp QC/T390-(40-45)	2	
3	255023520008	Rubber hose	1	
4	911000600003	Hose clamp QC/T390-(22-26)	2	
5	255023520006	Oil return hose φ23xφ13x3450	1	
6	911000600004	Hose clamp QC/T390-(34-38)	4	
7	255023520013	Oil return hose φ35xφ25x1750	1	
8	910800100002	Oring 13.2x2.65	2	
9	252023520011	Joint 8-2xM16x1.5-60°	2	
10	255023520002	Hydraulic hose assembly 8-L2550-1SC-60°	1	
11	255023520001	Hydraulic hose assembly 8-L2850-1SC-60°	1	
12	255023520004	Hydraulic hose assembly (90°)13-L2600-2SC-60°	1	
13	251023510005	Joint12-G1/2-M22x1.5-60°	1	
14	255023520022	Transition steel pipe	1	
15	910400100005	Washer GB97.1-6-200HV	2	
16	910400500005	Washer GB93-6	2	
17	910200200036	Screw GB70.1-M6x20-8.8	2	
18	255023510002	Joint 16-M22x1.5-φ25	1	
19	255023520021	Rubber tube	1	
20	251023510002	Joint 8-M18x1.5-M16x1.5-60°	3	
21	251023510001	Joint 11-M18x1.5-0	1	
22	255023510003	Joint 6-G1/4-M14x1.5-60°	1	
23	255023520003	Hydraulic hose assembly (90°)6-L1420-1SC-60°	1	
24	255023520005	Hydraulic hose assembly (90°)8-L1420-1SC-60°	1	
25	910800100015	Oring 19x2.65	1	
26	255023520030	Joint 12-2xM22x1.5-60°	1	

Hydraulic system

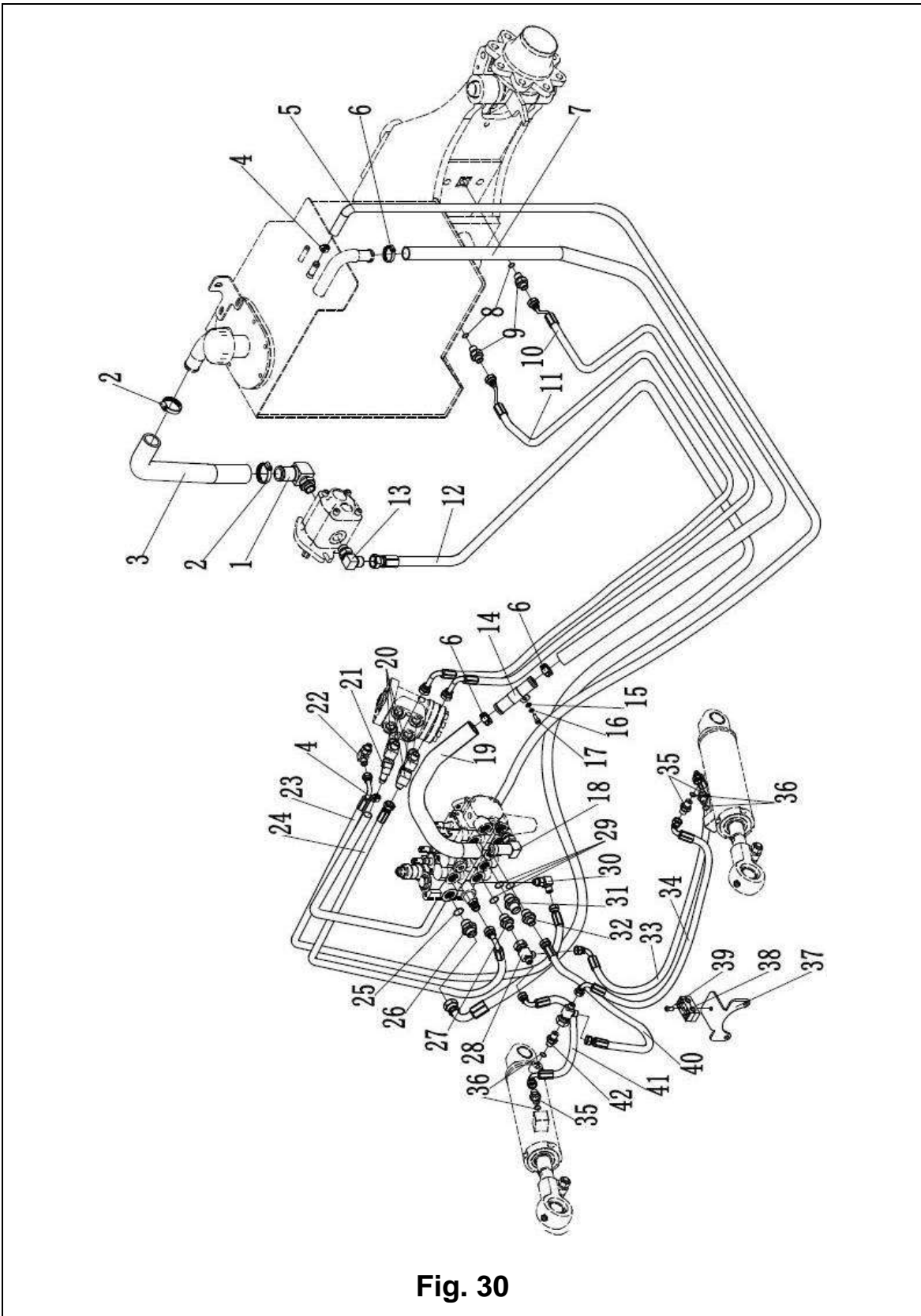

Fig. 30

Fig. 30**Hydraulic system**

No.	Coding	Description	Qty.	Note
27	253523520006	Joint 8-M20x1.5-M16x1.5-60°	1	
28	250523510001	Joint 7-2xM14x1.5-M16x1.5-60°	2	
29	910800100003	Oring 17x2.65	3	
30	255023510001	Joint 6-M12x1.5-M14x1.5-60°	1	
31	251043520043	Joint 12-M20x1.5-M22x1.5-60°	1	
32	251023520001	Joint 6-M20x1.5-M14x1.5-60°	1	
33	255023520017	Hydraulic hose assembly 6-L1000-1SC-60°	1	
34	255023520018	Hydraulic hose assembly 6-L1100-1SC-60°	1	
35	255023520007	Joint 6-G1/4—M14x1.5-60°	3	
36	910800100021	Oring 11.2x2.65	4	
37	255023520027	Rubber hose fixing block	1	
38	255028520034	Rubber hose fixing block	2	
39	910200200060	Screw GB70.1-M8x35-8.8	1	
40	255023520012	Hydraulic hose assembly 6-L500-1SC-60°	1	
41	255023520016	Hydraulic hose assembly 6-L600-1SC-60°	1	
42	255023520019	Joint 8-G1/4-M16x1.5-60°	1	

Mast lifting pipeline (standard mast)

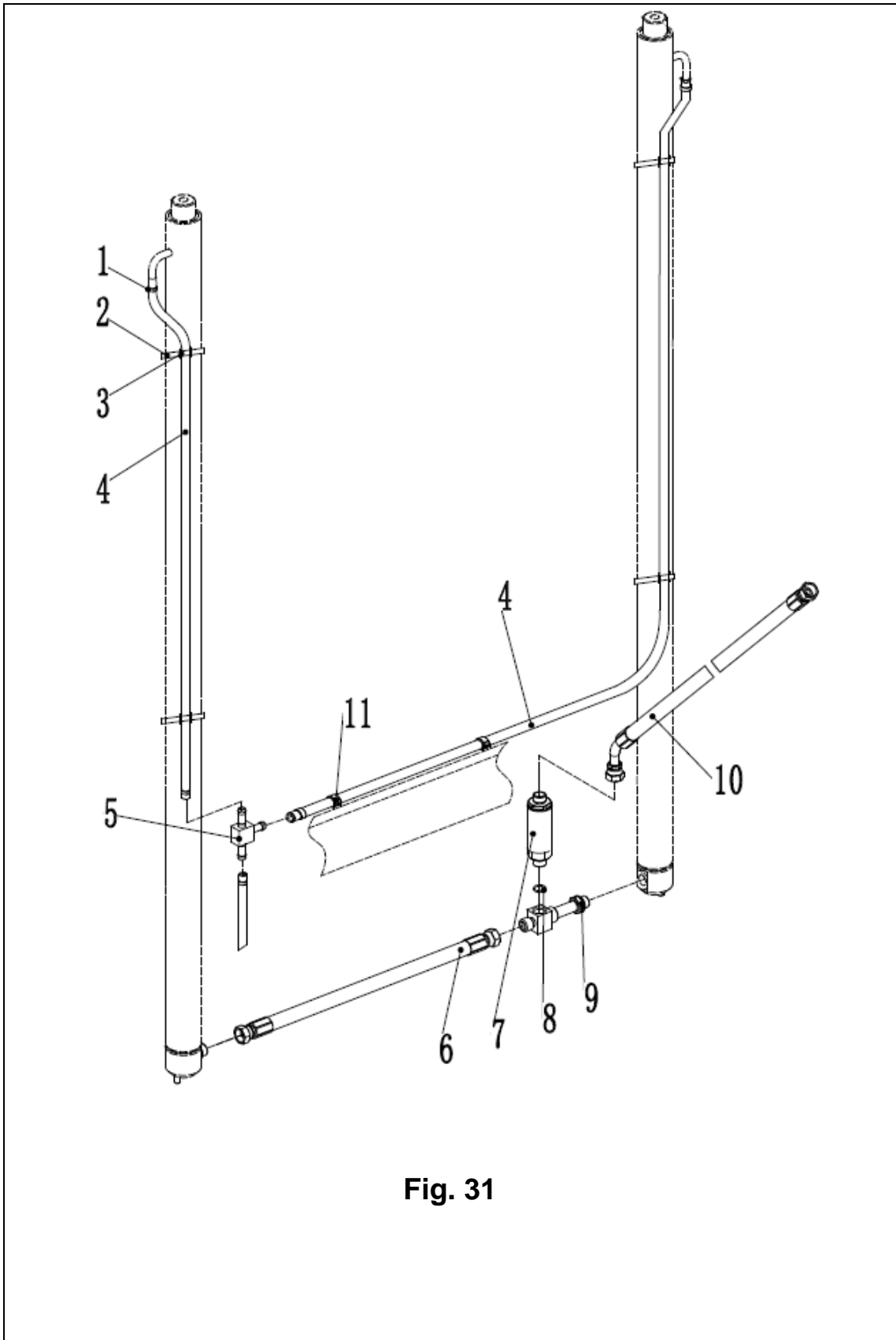

Fig. 31

Fig. 31 Mast lifting pipeline (standard mast)

No.	Coding	Description	Qty.	Note
1	255044020043	Hoop13	1	
2	921600400001	Strip 4x250	1	
3	255044020042	Press plate	1	
4	900200301004	PE Supple pipe Φ 10x Φ 13	1.7	▲
	900200301004	PE Supple pipe Φ 10x Φ 13	1.9	▲
	900200301004	PE Supple pipe Φ 10x Φ 13	2.2	▲
	900200301004	PE Supple pipe Φ 10x Φ 13	2.5	▲
	900200301004	PE Supple pipe Φ 10x Φ 13	2.7	▲
	900200301004	PE Supple pipe Φ 10x Φ 13	2.9	▲
	900200301004	PE Supple pipe Φ 10x Φ 13	3.3	▲
	900200301004	PE Supple pipe Φ 10x Φ 13	3.6	▲
	900200301004	PE Supple pipe Φ 10x Φ 13	3.8	▲
	900200301004	PE Supple pipe Φ 10x Φ 13	4.3	
5	251044020077	Joint	1	
6	254144020039	Hydraulic hose assembly 8-L370-2SC-60°	1	
7	275044010047	Speed limit valve XSF-F16L-30	1	
8	910800100003	Oring 17x2.65	1	
9	254144020038	Joint	1	
10	255044020013	Hydraulic hose assembly (45°) 13-L680-2SC-60°	1	
11	921600400003	Strip P-N156-00646	2	

Note: ▲ spare parts will not be provided seperately

Mast lifting pipeline(two stage full free lift)

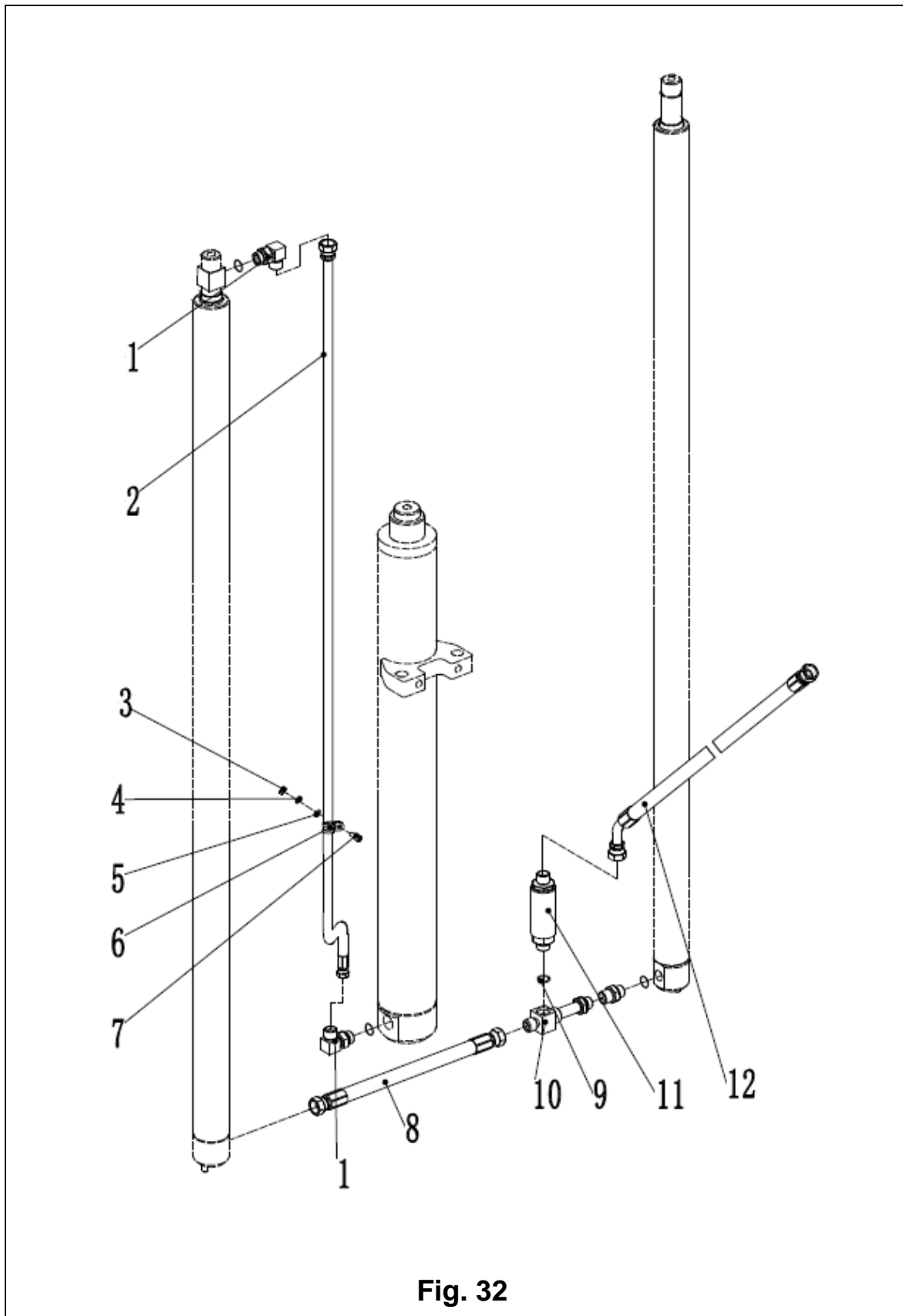

Fig. 32

Fig. 32 Mast lifting pipeline(two stage full free lift)

No.	Coding	Description	Qty.	Note
1	253523520005	Joint 12-2xM22x1.5-60°	1	
2	254143520050	Rise steel pipe L=1350	1	H=2500
	254143520051	Rise steel pipe L=1450	1	H=2700
	254143520052	Rise steel pipe L=1600	1	H=3000
	254143520053	Rise steel pipe L=1750	1	H=3300
	254143520054	Rise steel pipe L=1850	1	H=3500
	254143520055	Rise steel pipe L=1950	1	H=3700
	254143520056	Rise steel pipe L=2150	1	H=4000
	254143520057	Rise steel pipe L=2300	1	H=4300
	254143520058	Rise steel pipe L=2400	1	H=4500
	254143520059	Rise steel pipe L=2675	1	H=5000
3	910300100005	Nut GB6170-M6-10	1	
4	910400500005	Spring gasket GB93-6	1	
5	910400100005	Flat gasket GB97.1-6-200HV	1	
6	951000100003	Hose clamp YGE wrap glue 15	1	
7	255043520008	Hydraulic hose	1	
8	254144020039	Hydraulic hose assembly 8-L370-2SC-60°	1	
9	910800100003	Oring 17x2.65	1	
10	254144020038	Joint	1	
11	275044010047	Speed limit valve XSF-F16L-30	1	
12	255044020013	Hydraulic hose assembly 13-L740-2SC-60°	1	

Mast lifting pipeline(three stage full free lift)

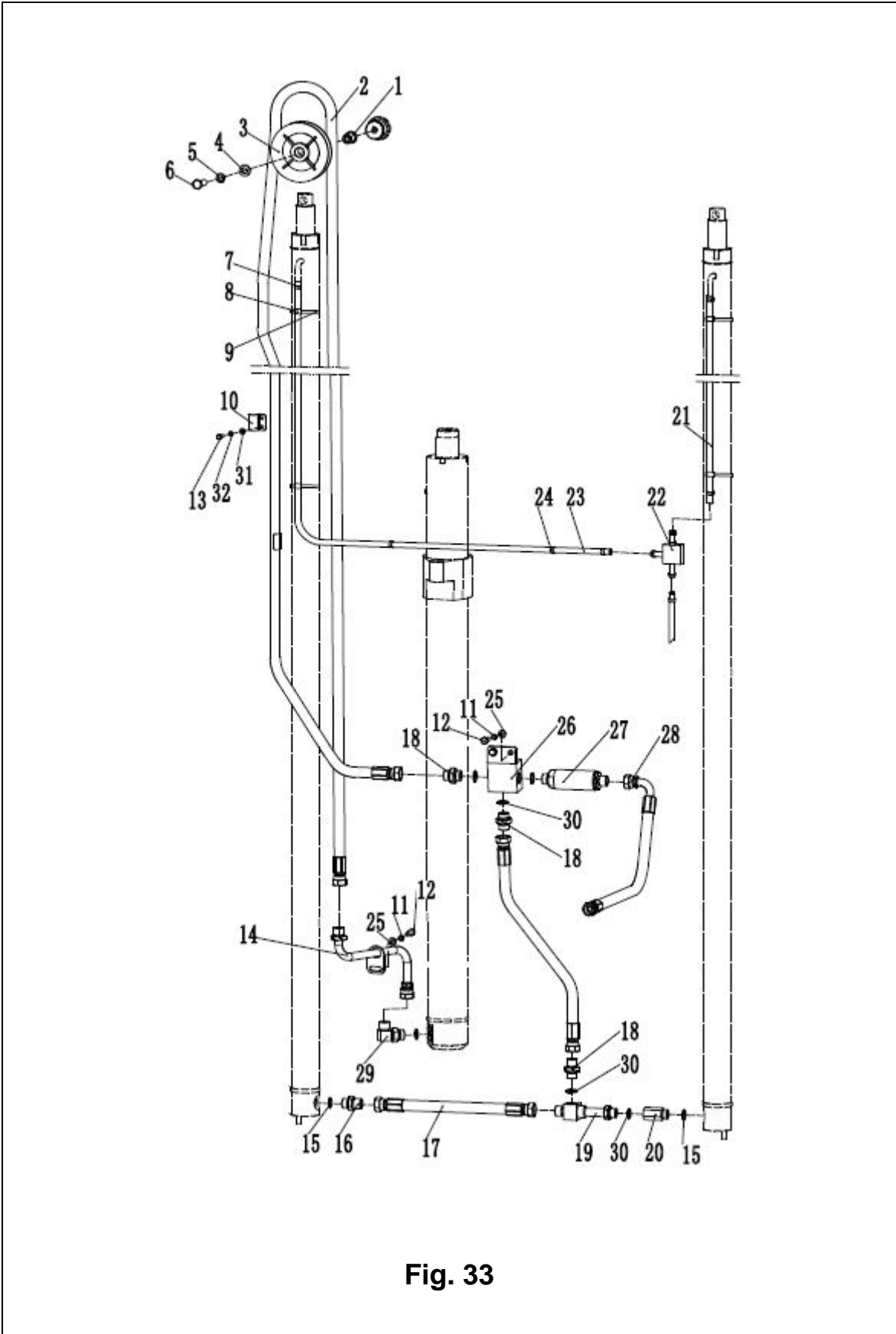

Fig. 33

Fig. 33 Mast lifting pipeline(three stage full free lift)

No.	Coding	Description	Qty.	Note
1	255044520081	Bushing	1	
2	254144520041	Hydraulic hose assembly 13-L2850-2CS-60°	1	H=4000
	254144520042	Hydraulic hose assembly 13-L3100-2CS-60°	1	H=4350
	254144520043	Hydraulic hose assembly 13-L3200-2CS-60°	1	H=4500
	254144520044	Hydraulic hose assembly 13-L3400-2CS-60°	1	H=4800
	254144520045	Hydraulic hose assembly 13-L3600-2CS-60°	1	H=5000
	254144520046	Hydraulic hose assembly 13-L3900-2CS-60°	1	H=5500
	254144520047	Hydraulic hose assembly 13-L4300-2CS-60°	1	H=6000
3	255030520021	Pulley ϕ 110x27(single groove)	1	
4	910400100008	Washer GB97.1-12-200HV	1	
5	910400500008	Washer GB93-12	1	
6	910100300054	Bolt GB5783-M12x50-8.8	1	
7	255044020043	Hoop	1	
8	921600400001	Strip 4x250	6	
9	255044020042	Hose press plate	6	
10	254144520049	Oil pipe press plate	1	
11	910400500006	Washer GB93-8	5	
12	910100300022	Bolt GB5783-M8x20-8.8	1	
13	910100300010	Bolt GB5783-M6x16-8.8	1	
14	254144510021	Medium urn traist steel pipe	1	
15	910800100003	Oring 17x2.65	2	
16	251043520043	Joint 12-M20x1.5-M22x1.5-60°	2	
17	254144020039	Hydraulic hose assembly 13-L350-2SC-60°	1	

Mast lifting pipeline(three stage full free lift)

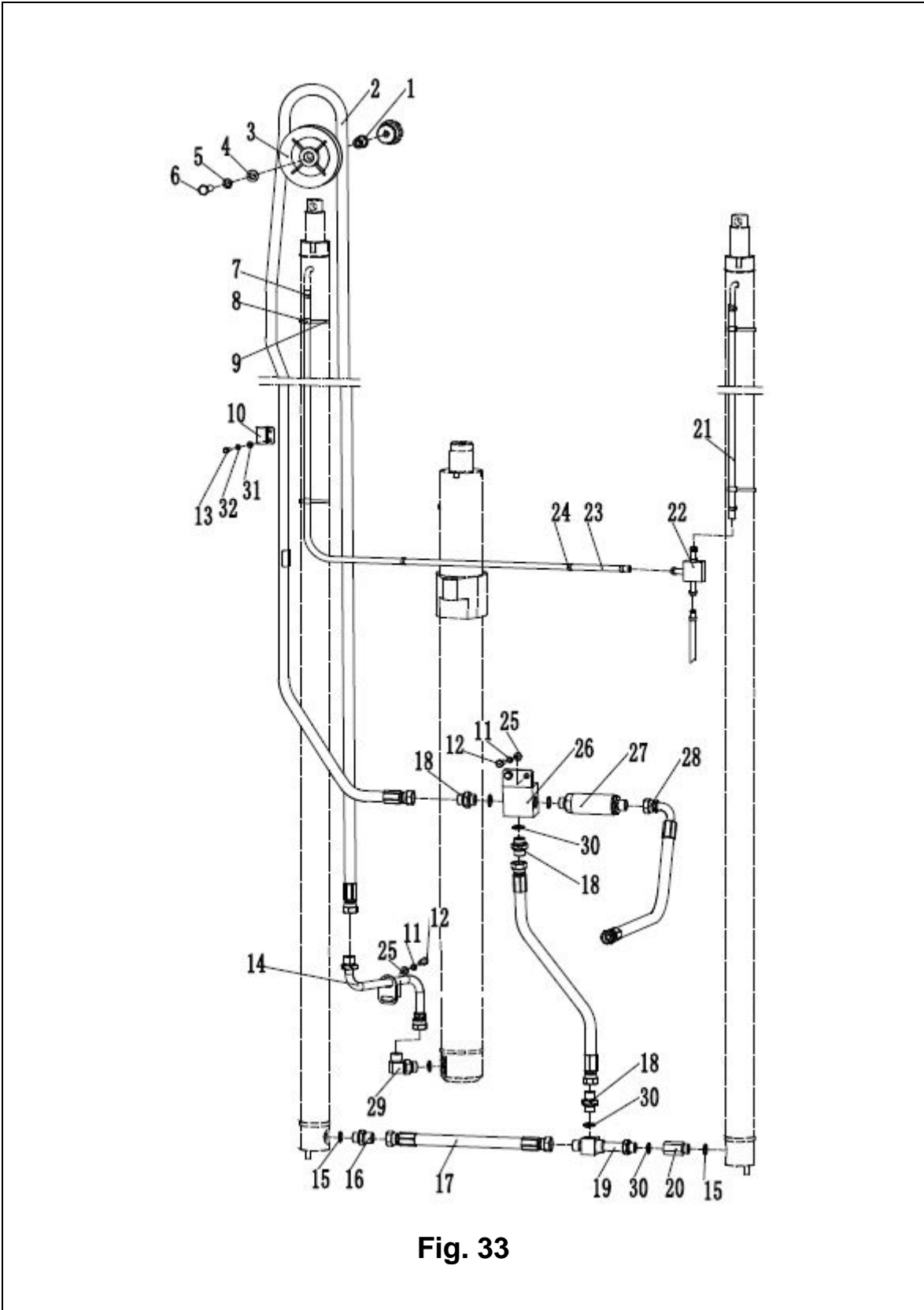

Fig. 33

Fig. 33 Mast lifting pipeline(three stage full free lift)

No.	Coding	Description	Qty.	Note
18	254144520040	Joint 10-M22x1.5-M18x1.5-60°	3	
19	254144020038	Joint	1	
20	255044520080	Joint	1	
21	00200301004	PE soft pipe $\Phi 10 \times \Phi 139$	As required	▲
22	251044020077	Joint	1	
23	00200301004	PE soft pipe $\Phi 10 \times \Phi 139$	As required	▲
24	921600400003	Strip P/N 156-00646	2	
25	910400100006	Washer GB97.1-8-200HV	3	
26	254144510022	Three joint welding	1	
27	254144020039	Speed limit valve XSF-F16L-30	1	
28	254144520048	Hydraulic hose assembly (90°) 13-L1000-2SC-60°	1	
29	255043520022	Joint 8-M27x2-M22x1.5-60°	1	
30	910800100015	Oring 19x2.65	4	
31	910400100005	Washer GB97.1-6-200HV	4	
32	910400500005	Washer GB93-6	4	

Note: ▲ spare parts will not be provided separately

Side shifter and pipeline installation (standard mast)

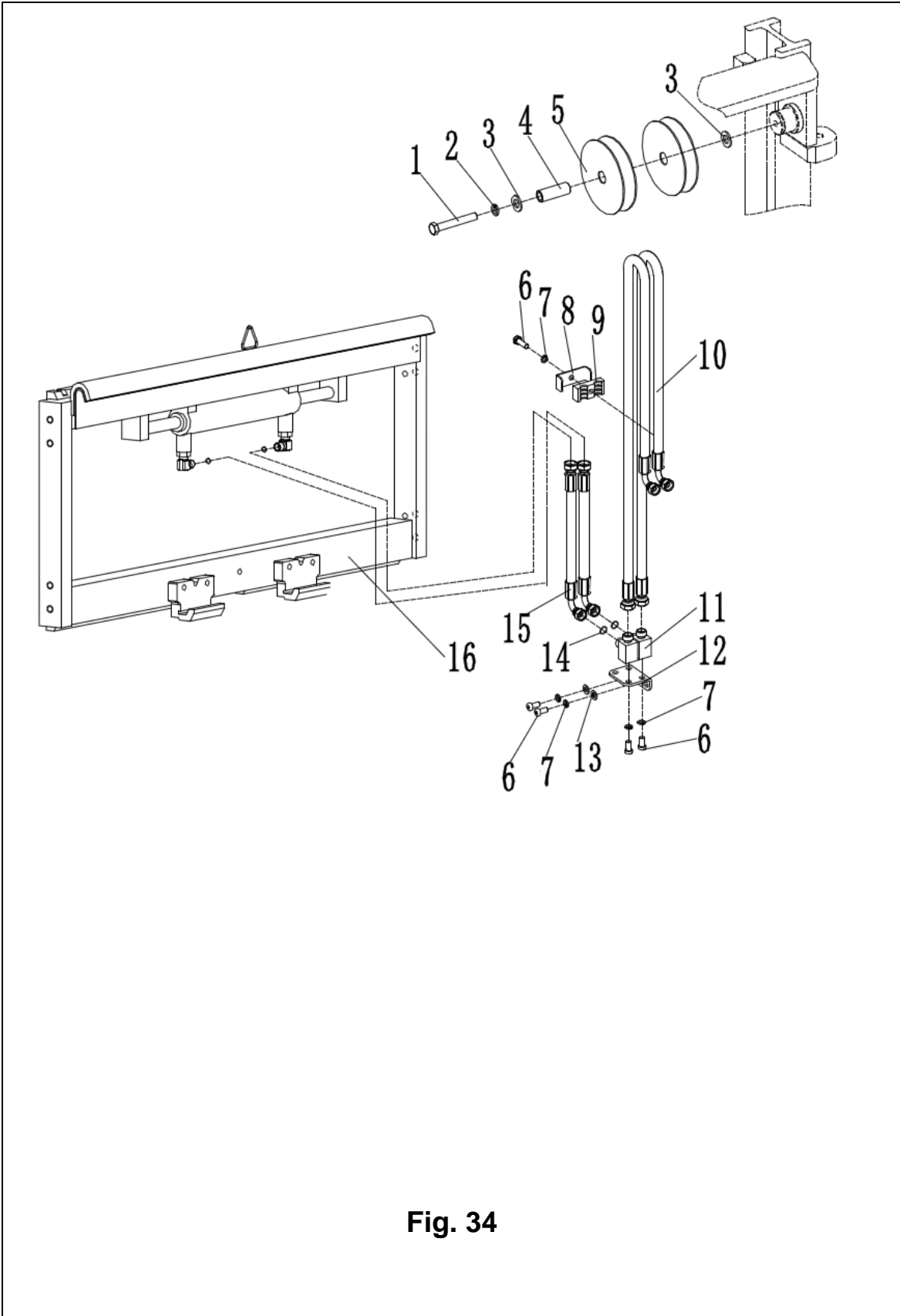

Fig. 34

Fig. 34 Side shifter and pipeline installation (standard mast)

No.	Coding	Description	Qty.	Note
1	910100100056	Bolt GB5782-M12x90-8.8	1	
2	910400500008	WasherGB93-12	1	
3	910400100008	Washer GB97.1-12-200HV	1	
4	255030520022	Bush $\Phi 22 \times \Phi 13 \times 56$	1	
5	255030520021	Pulley $\Phi 110 \times 27$	2	
6	910200200059	ScrewGB70.1-M8x30-8.8	2	
7	910400500006	Washer GB93-8	6	
8	255028520034	Rubber pipe lump	2	
9	255028520035	Pipe press fixedly plank	2	
10	254127520002	Hydraulic hose assembly (90°)8-L3000-1SC-60°	2	H=2500
	254127520003	Hydraulic hose assembly (90°)8-L3200-1SC-60°	2	H=2700
	254127520004	Hydraulic hose assembly(90°)8-L3500-1SC-60°	2	H=3000
	252030520013	Hydraulic hose assembly(90°)8-L3800-1SC-60°	2	H=3300
	252027520005	Hydraulic hose assembly(90°)8-L4000-1SC-60°	2	H=3500
	253528520028	Hydraulic hose assembly(90°)8-L4200-1SC-60°	2	H=3700
	254127520008	Hydraulic hose assembly(90°)8-L4600-1SC-60°	2	H=4000
	253528520032	Hydraulic hose assembly(90°)8-L4900-1SC-60°	2	H=4300
	253530520007	Hydraulic hose assembly(90°)8-L5100-1SC-60°	2	H=4500
	254127520011	Hydraulic hose assembly(90°)8-L5650-1SC-60°	2	H=5000
11	255028520001	Joint 8-M16x1.5-M18x1.5-60°	2	
12	254127520001	fixedly plank	1	
13	910400100006	Washer GB97.1-8-200HV	2	
14	910800100001	Oring 9.5x1.8	4	
15	253542520001	Front short pipe	2	
16	253042510001	Side shifter assembly	1	

Side shifter and pipeline installation(two stage full free)

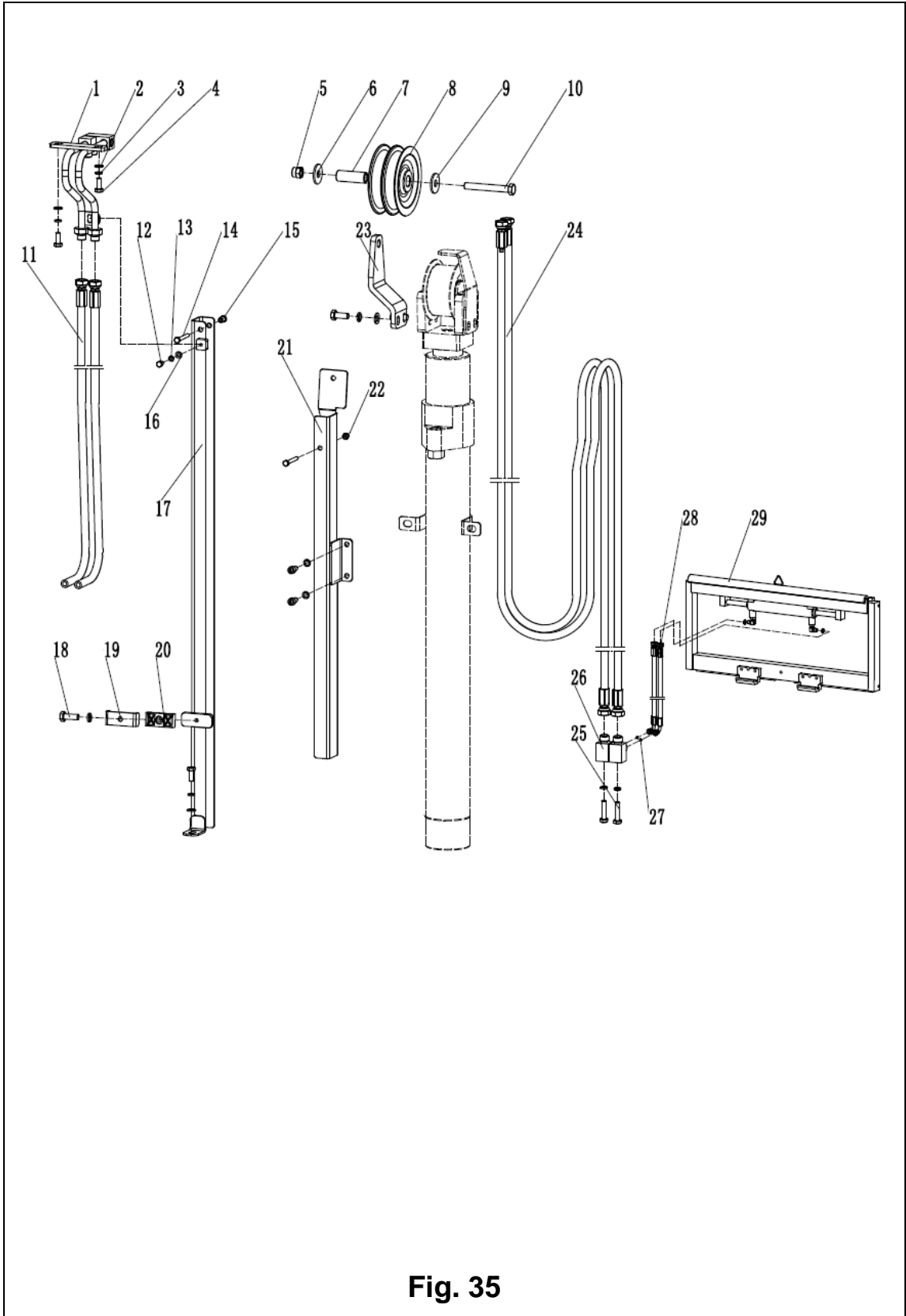

Fig. 35

Fig. 35 Side shifter and pipeline installation(two stage full free)

No.	Coding	Description	Qty.	Note
1	254128510001	Transition steel pipe solder	1	
2	910400100006	Washer GB97.1-8-200HV	2	
3	910400500006	Washer GB93-8	2	
4	941100400001	ScrewM8X20-8.8	2	
5	910300500006	Nut GB889.1-M12-10	1	
6	910400100008	Washer GB97.1-12-200HV	1	
7	255030520022	Bushing	1	
8	255030520021	Pulley φ110x27	1	
9	910400200005	Washer GB97.1-12-200HV	1	
10	910100300025	Bolt GB5783-M8x35-8.8	1	
11	254128520041	Hydraulic hose assembly (90°)8-L1650-1SC-60°	2	H=2500
	254128520042	Hydraulic hose assembly (90°)8-L1750-1SC-60°	2	H=2700
	254128520043	Hydraulic hose assembly (90°)8-L1900-1SC-60°	2	H=3000
	254128520044	Hydraulic hose assembly (90°)8-L2050-1SC-60°	2	H=3300
	250528520002	Hydraulic hose assembly (90°)8-L2150-1SC-60°	2	H=3500
	254128520046	Hydraulic hose assembly (90°)8-L2250-1SC-60°	2	H=3700
	252028520019	Hydraulic hose assembly (90°)8-L2450-1SC-60°	2	H=4000
	254128520048	Hydraulic hose assembly (90°)8-L240-1SC-60°	2	H=4300
	252028520020	Hydraulic hose assembly (90°)8-L2700-1SC-60°	2	H=4500
	254128520050	Hydraulic hose assembly (90°)8-L2975-1SC-60°	2	H=5000
12	941100100009	Screw M6X12-8.8	1	
13	910400500005	Washer GB93-8	1	
14	910100300016	BoltGB5783-M6X50-8.8	2	
15	910301300002	Nut GB17880.1-M6X16.5	1	
16	910400100005	Washer GB97.1-6-200HV		

Side shifter and pipeline installation(two stage full free)

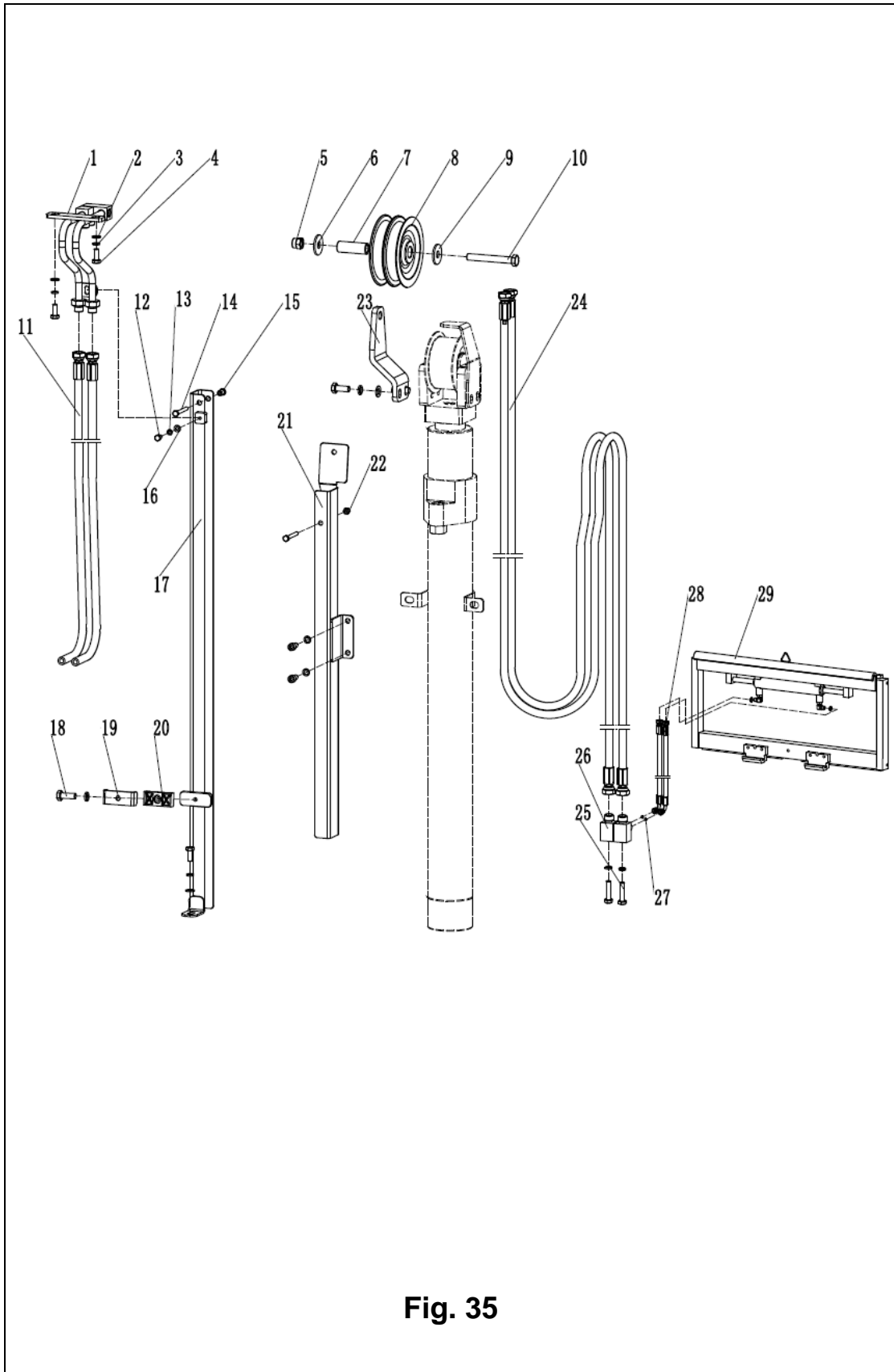

Fig. 35

Fig. 35 Side shifter and pipeline installation(two stage full free)

No.	Coding	Description	Qty.	Note
17	254128510012	Groove welding L=720	1	H=2500
	254128510013	Groove welding L=820	1	H=2700
	254128510014	Groove welding L=970	1	H=3000
	254128510015	Groove welding L=1120	1	H=3300
	254128510016	Groove welding L=1220	1	H=3500
	254128510017	Groove welding L=1320	1	H=3700
	254128510018	Groove welding L=1520	1	H=4000
	254128510019	Groove welding L=1670	1	H=4300
	254128510020	Groove welding L=1770	1	H=4500
	254128510021	Groove welding L=2045	1	H=5000
18	910200200059	Screw GB70.1-M6x30-8.8	1	
19	255028520035	Rubber pipe lump	2	
20	255028520034	Pipe press fixedly plank	2	
21	254128510002	Groove welding L=400	1	H=2500
	254128510003	Groove welding L=500	1	H=2700
	254128510004	Groove welding L=650	1	H=3000
	254128510005	Groove welding L=800	1	H=3300
	254128510006	Groove welding L=900	1	H=3500
	254128510007	Groove welding L=1000	1	H=3700
	254128510008	Groove welding L=1200	1	H=4000
	254128510009	Groove welding L=1350	1	H=4300
	254128510010	Groove welding L=1450	1	H=4500
	254128510011	Groove welding L=1725	1	H=5000
22	910300500003	Nut GB889.1-M6-10	1	
23	254143520055	Pulley frame	1	
24	254128520031	Hydraulic hose assembly 8-L2350-1SC-60°	2	H=2500/ 2700
	252028520015	Hydraulic hose assembly 8-L250-1SC-60°	2	H=3000/ 3300

Side shifter and pipeline installation(two stage full free)

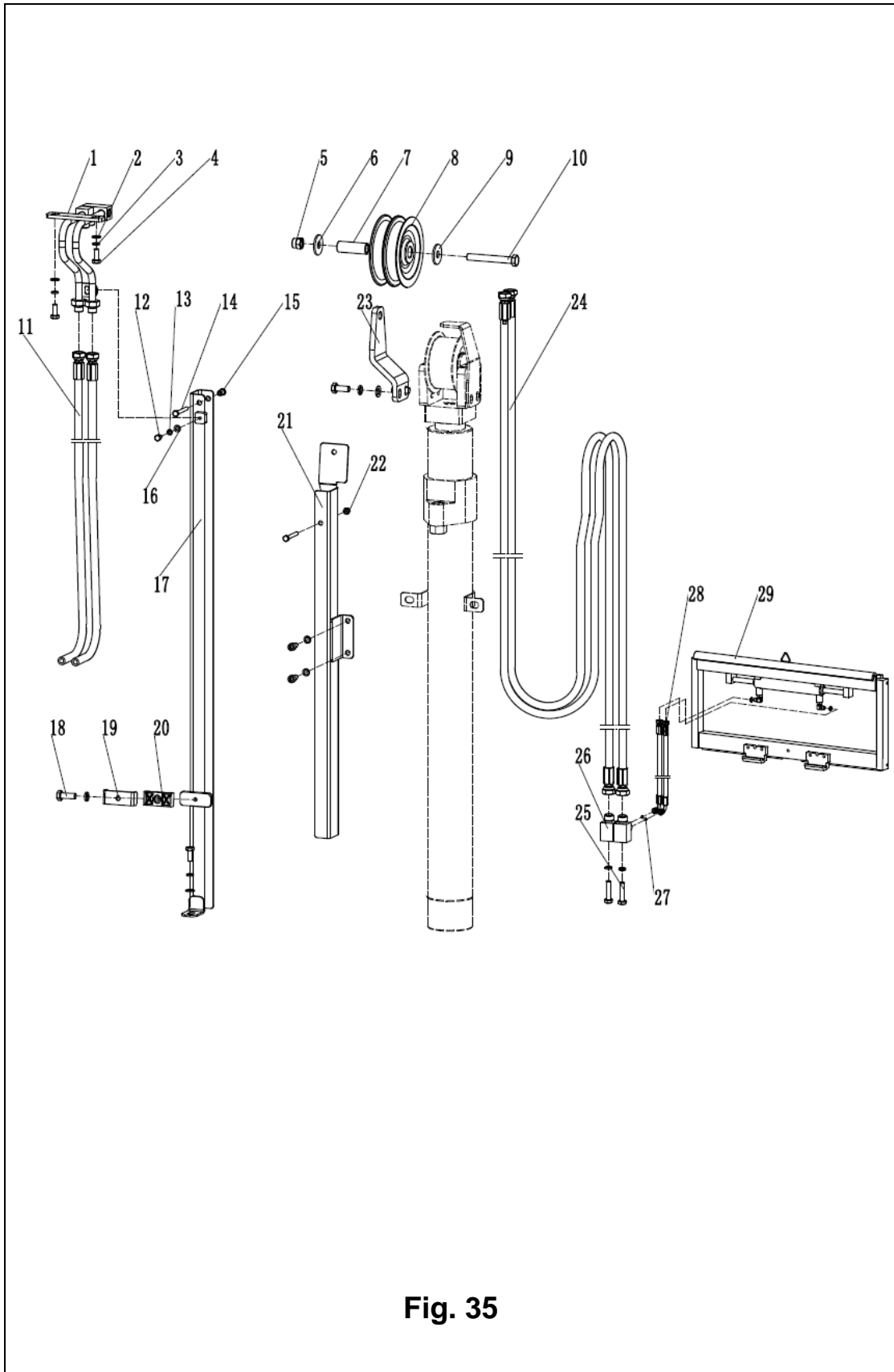

Fig. 35

Fig. 35 Side shifter and pipeline installation(two stage full free)

No.	Coding	Description	Qty.	Note
24	254128520035	Hydraulic hose assembly 8-L2850-1CS-60°	2	H=3500/3700
	254128520037	Hydraulic hose assembly 8-L3150-1CS-60°	2	H=4000/4300
	254128520039	Hydraulic hose assembly 8-L3250-1CS-60°	2	H=4500
	254128520040	Hydraulic hose assembly 8-L3500-1CS-60°	2	H=5000
25	910100300025	Bolt GB5783-M8x35-8.8	2	
26	255028520001	Joint 16-18	2	
27	910800100001	Oring 9.5x1.8	4	
28	253542520001	Hose	2	
29	253042510001	Side shifter assembly	1	

Fig. 36 Side shifter and pipeline installation(three stage full free)

No.	Coding	Description	Qty.	Note
1	910100300054	BoltGB5783-M12x50-8.8	1	
2	910400500008	Washer GB93-12	1	
3	910400100008	Washer GB97.1-12-200HV	2	
4	255030520020	Pulley	1	
5	255030520001	Hydraulic hose assembly 8-L2060-1CS-60°	1	H=4000
	255030520002	Hydraulic hose assembly 8-L2310-1CS-60°	1	H=4350
	255030520003	Hydraulic hose assembly 8-L2410-1CS-60°	1	H=4500
	255030520004	Hydraulic hose assembly 8-L2610-1CS-60°	1	H=4800
	254130520001	Hydraulic hose assembly 8-L2810-1CS-60°	1	H=5000
	254130520002	Hydraulic hose assembly 8-L3110-1CS-60°	1	H=5500
	254130520003	Hydraulic hose assembly 8-L3850-1CS-60°	1	H=6000
6	255030520023	Bushing1	1	
7	910100100056	Bolt GB5782-M12x90-8.8	1	
8	910400500008	Washer GB93-12	1	
9	910400100008	Washer GB97.1-12-200HV	1	
10	255030520022	Bushing	1	
11	25413052004	Hydraulic hose assembly 8-L1745-1CS-60°	2	H=4000
	25413052005	Hydraulic hose assembly 8-L1870-1CS-60°	2	H=4350
	255030520016	Hydraulic hose assembly 8-L1920-1CS-60°	2	H=4500
	25413052006	Hydraulic hose assembly 8-L2020-1CS-60°	2	H=4800
	25413052007	Hydraulic hose assembly 8-L2120-1CS-60°	2	H=5000
	25413052008	Hydraulic hose assembly 8-L2295-1CS-60°	2	H=5500
	25413052009	Hydraulic hose assembly 8-L2470-1CS-60°	2	H=6000

Side shifter and pipeline installation(three stage full free)

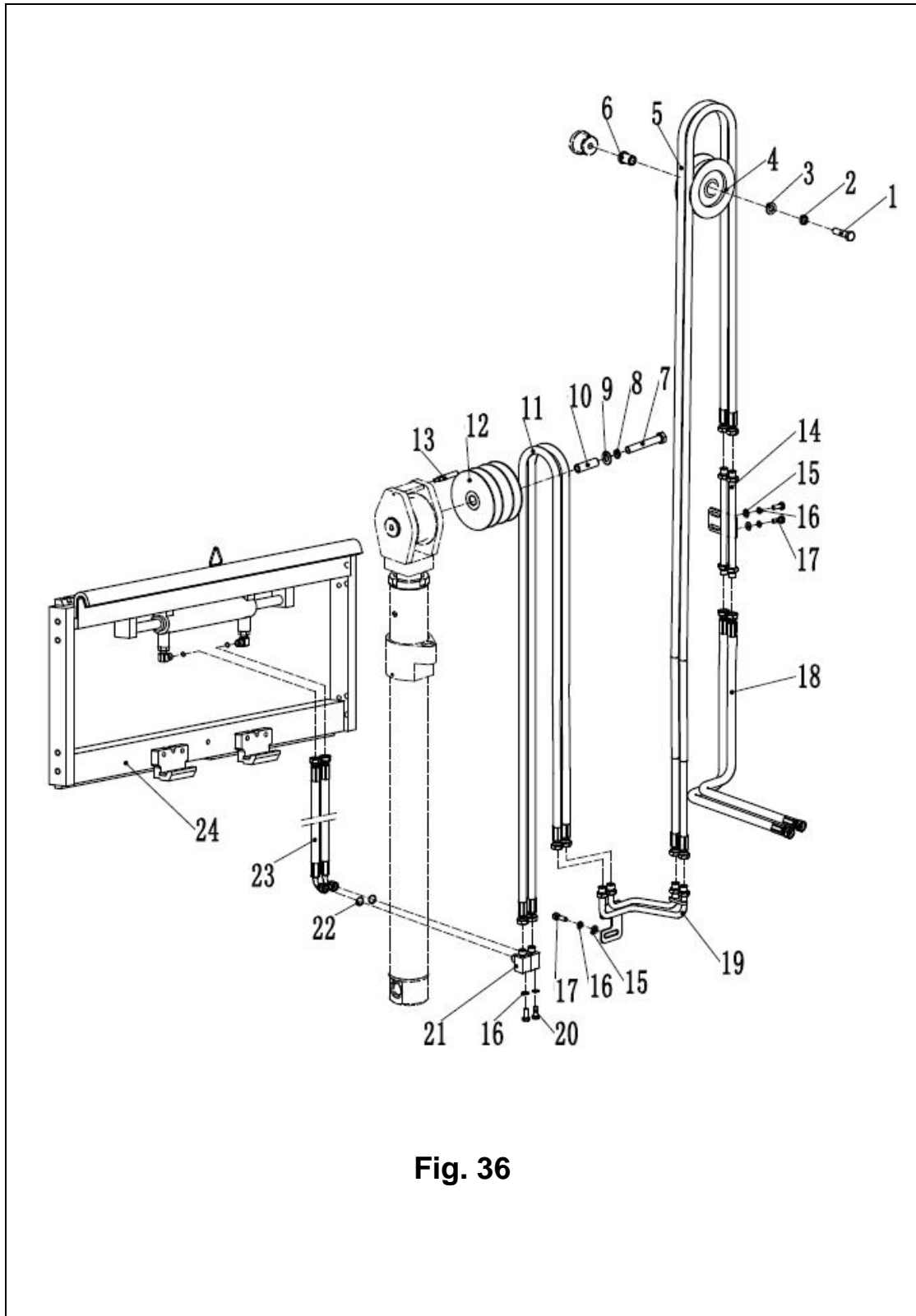

Fig. 36

Fig. 36 Side shifter and pipeline installation(three stage full free)

No.	Coding	Description	Qty.	Note
12	255030520021	Pulley ϕ 110x27	2	
13	254130520014	Pulley pole	1	
14	255030520018	Hydraulic steel pipe welding	1	
15	910400100006	Washer GB97.1-16-200HV	3	
16	910400100006	Washer GB93-8	5	
17	910100300022	Bolt GB5783-M8x20-8.8	3	
18	254130520015	Hydraulic hose assembly (90°)8-L500-1SC-90°	2	
19	254130510001	Sidesway steel pipe	1	
20	910200200059	Screw GB70.1-M8x35-8.8	2	
21	255028520001	Joint 16-18	2	
22	910800100001	Oring 9.5x1.8	4	
23	253542520001	Hydraulic hose assembly (90°)8-L500-1SC-90°	2	
24	253042510001	Side shift assembly	1	

Fork

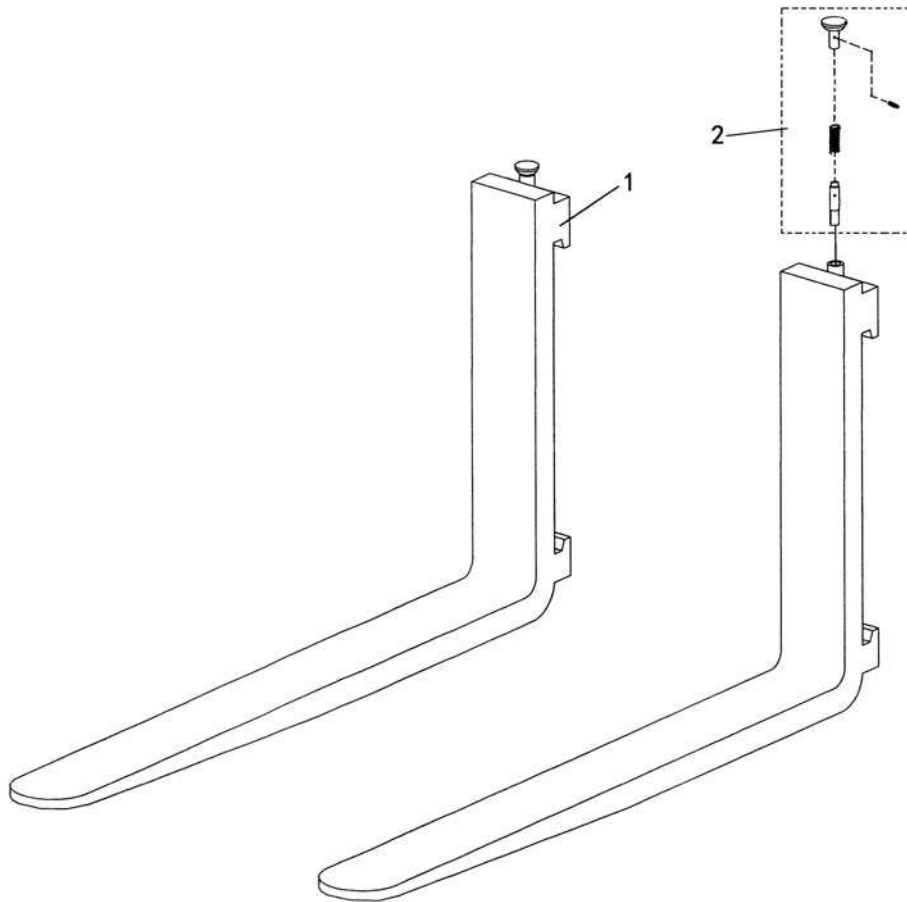

Fig. 37

Fig. 37**Fork**

No.	Coding	Description	Qty.	Note
A	940100100001	Fork 100x35x920	2	Inc.1-2
	940100100002	Fork 100x35x950	2	
	940100100003	Fork 100x35x1070	2	
	940100100004	Fork 100x35x1150	2	
	940100100005	Fork 100x35x1220	2	
1		Fork body	2	▲
2	253098514101	Lift pin assembly	2	

Note: ▲ spare parts will not be provided separately

Fork carrier(standard mast)

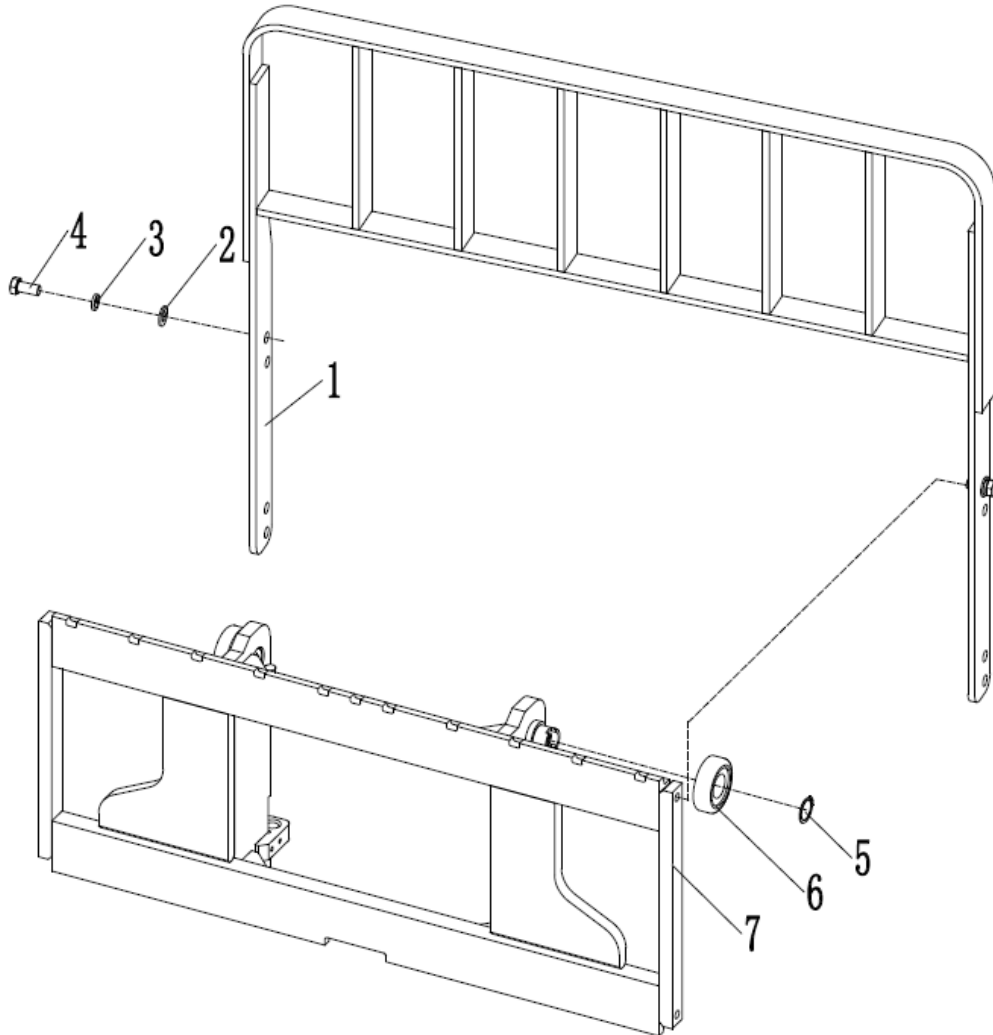

Fig. 38

Fig. 38 Fork carrier(standard mast)

No.	Coding	Description	Qty.	Note
1	253040510001	Load backrest welding	1	
2	910100300062	Bolt GB5783-M14x30-8.8	8	
3	910400500009	Washer GB93-14	8	
4	910400100009	Washer GB97.1-14-200HV	8	
5	910401300017	Circlip GB894.1-32	4	
6	940200300004	Roller $\phi 77.7$ -range=45.3-49.3	4	
7	254138010001	Fork carrier weldind (standard mast)	1	

Fork carrier(two stage full free)

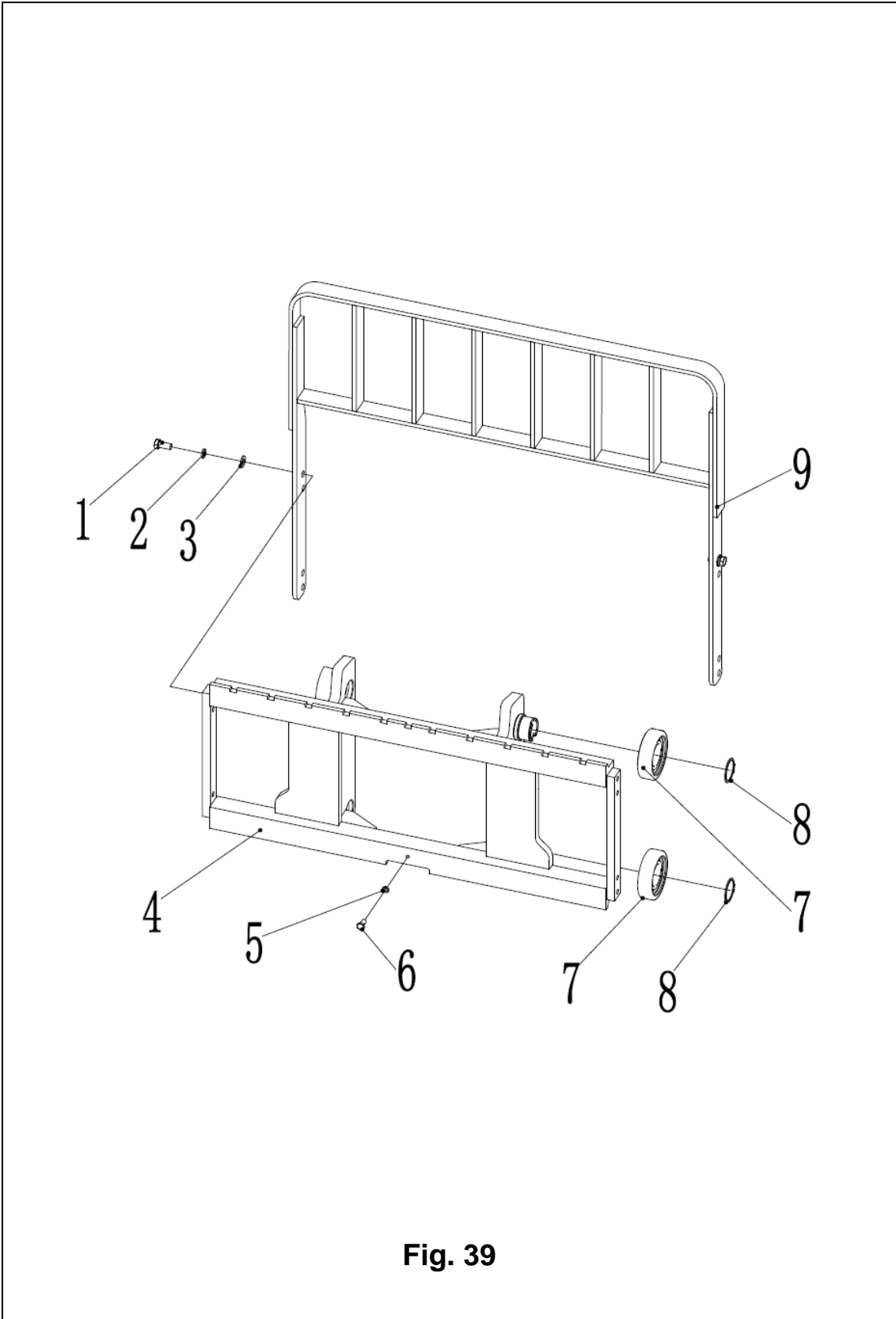

Fig. 39

Fig. 39 Fork carrier(two stage full free)

No.	Coding	Description	Qty.	Note
1	910100300062	Bolt GB5783-M14x30-8.8	8	
2	910400500009	Washer GB93-14	8	
3	910400100009	Washer GB97.1-14-200HV	8	
4	254138010011	Fork carrier welding(two stage full free)	1	
5	910200200077	ScrewGB70.1-M10x30-8.8	1	
6	910400100007	Washer GB97.1-14-200HV	1	
7	940200300004	Roller φ119.2-range=59.5-64.5	4	
8	910401300017	Circlip GB894.1-55	4	
9	253040510001	Fork carrier welding	1	

Fork carrier(three stage full free)

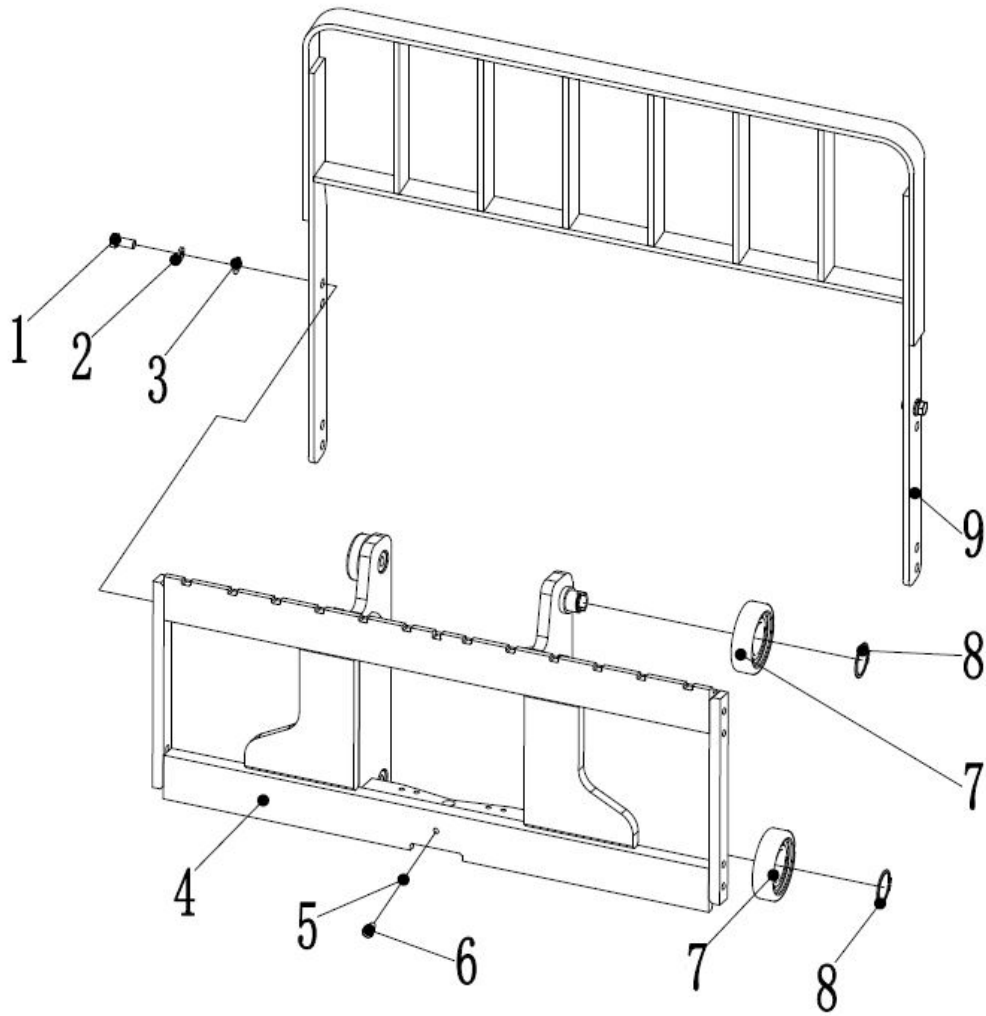

Fig. 40

Fig. 40 Fork carrier(three stage full free)

No.	Coding	Description	Qty.	Note
1	910100300062	Bolt GB5783-M14x30-8.8	8	
2	910400500009	Washer GB93-14	8	
3	910400100009	Washer GB97.1-14-200HV	8	
4	254138010021	Fork carrier welding	1	
5	910400500007	Washer GB93-10	1	
6	910200200077	Screw GB70.1-M10x30-8.8	1	
7	940200300007	Roller ϕ 78.3-range=45.3-49.3	4	
8	910401300017	Circlip GB894.1-32	4	
9	253040510001	Fork carrier welding	1	

Mast (standard mast)

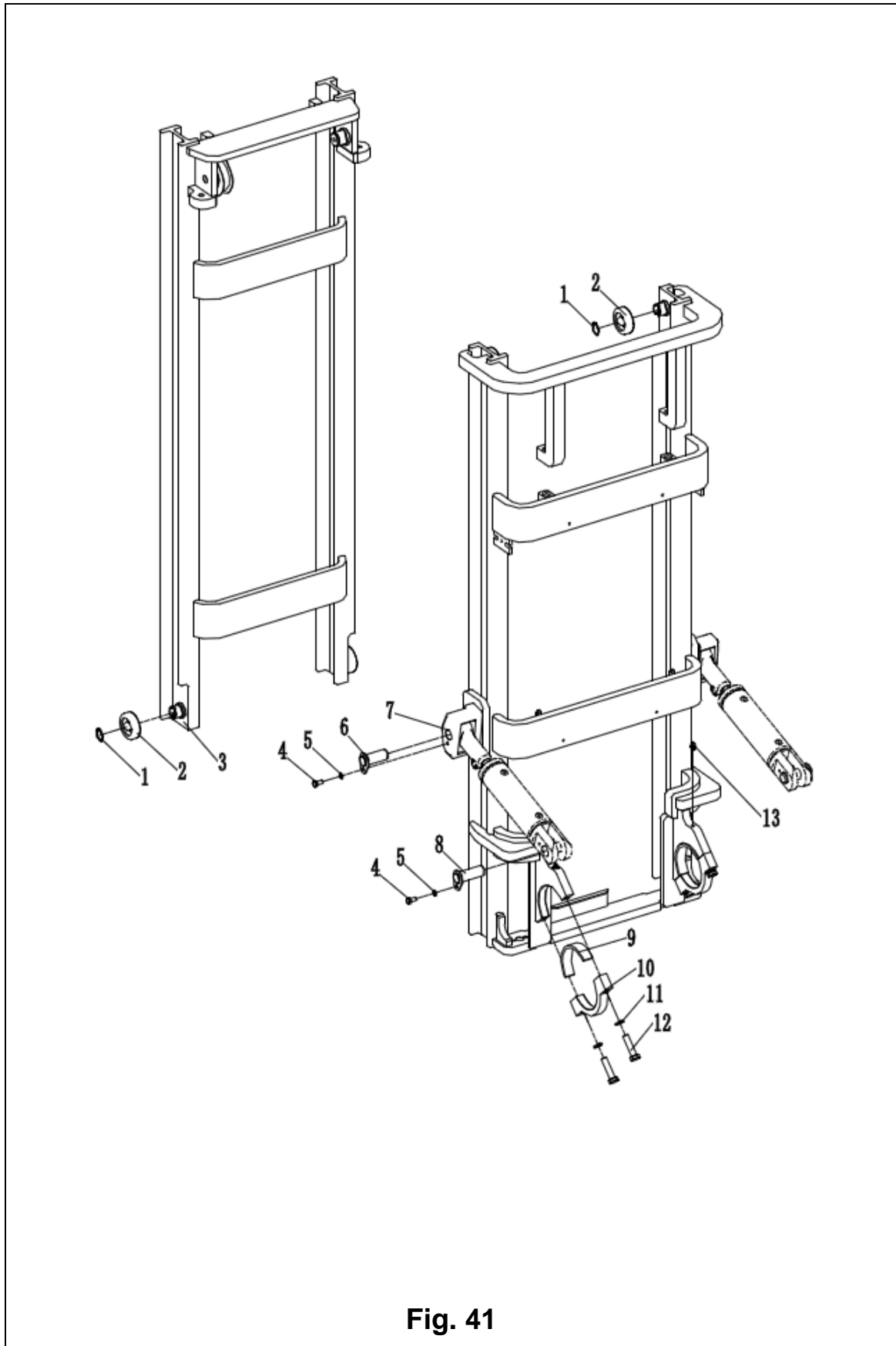

Fig. 41

Fig. 41 Mast (standard mast)

No.	Coding	Description	Qty.	Note
1	910401300017	Circlip GB894.1-32	4	
2	940200300007	Roller ϕ 78.3-range=45.3-49.3	4	
3	254144010011	Mast 2500	1	H=2500
	254144010012	Mast 2700	1	H=2700
	254144010013	Mast 3000	1	H=3000
	254144010014	Mast 3300	1	H=3300
	254144010015	Mast 3500	1	H=3500
	254144010016	Mast 3700	1	H=3700
	254144010017	Mast 4000	1	H=4000
	254144010018	Mast 4300	1	H=4300
	254144010019	Mast 4500	1	H=4500
	254144010020	Mast 5000	1	H=5000
4	910100300035	Bolt GB5783-M10x20-8.8	4	
5	910400500007	Washer GB93-16	4	
6	253520510005	Axle ϕ 30x82	2	
7	254144010001	Mast 2500	1	H=2500
	254144010002	Mast 2700	1	H=2700
	254144010003	Mast 3000	1	H=3000
	254144010004	Mast 3300	1	H=3300
	254144010005	Mast 3500	1	H=3500
	254144010006	Mast 3700	1	H=3700
	254144010007	Mast4000	1	H=4000
	254144010008	Mast 4300	1	H=4300
	254144010009	Mast 4500	1	H=4500

Mast (standard mast)

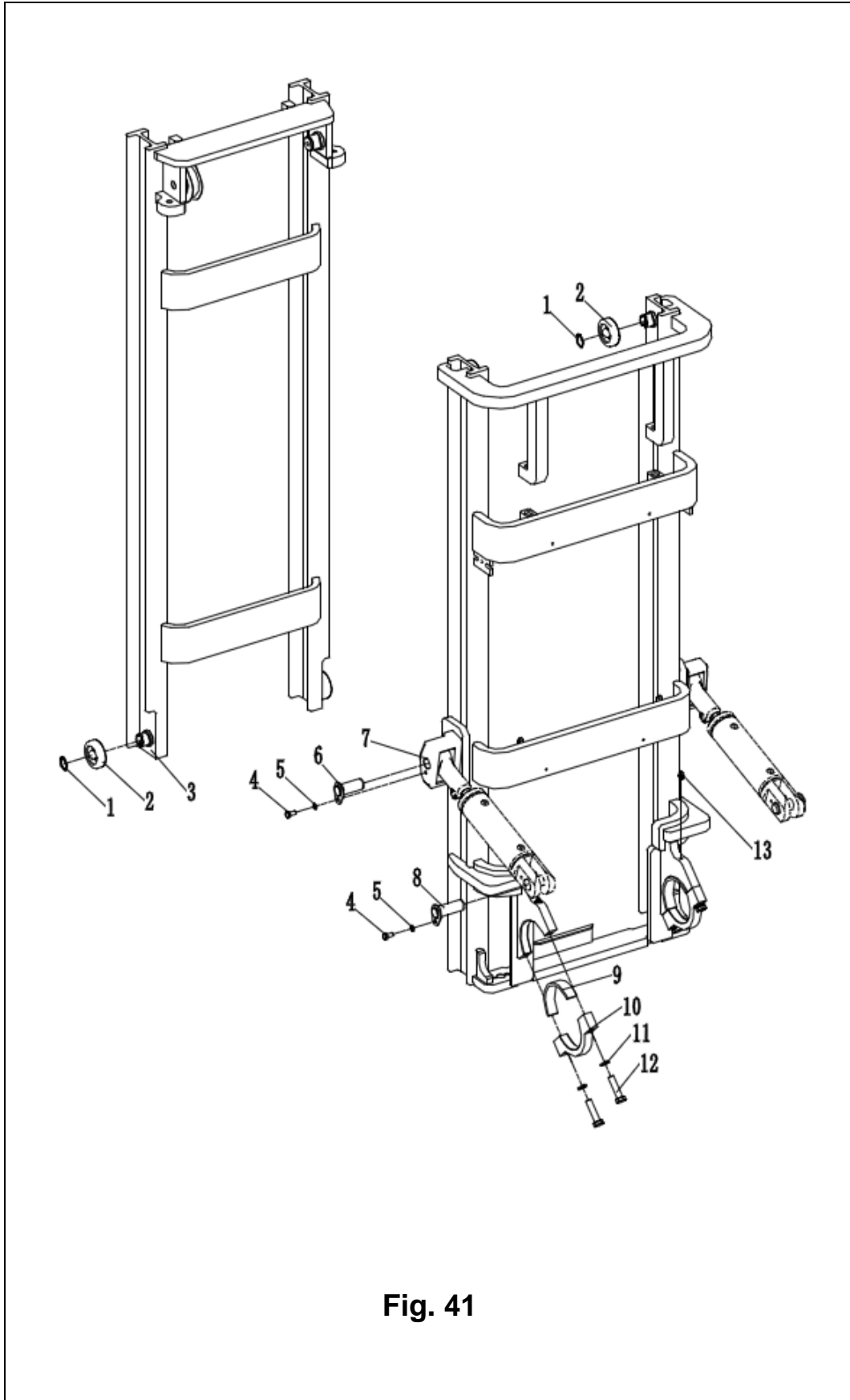

Fig. 41

Fig. 41 Mast (standard mast)

No.	Coding	Description	Qty.	Note
7	254144010010	Mast 5000	1	H=5000
8	253520510001	Axle ϕ 30x82	2	
9	253544020001	Bearing bush	2	
10	251044020065	Bearing cover	2	
11	910400500010	Washer GB93-16	4	
12	910100200016	Bolt GB5785-M16x1.5x70-8.8	4	
13	911200100004	Grease nipple JB7940.1-M10x1	2	

Mast (two stage full free)

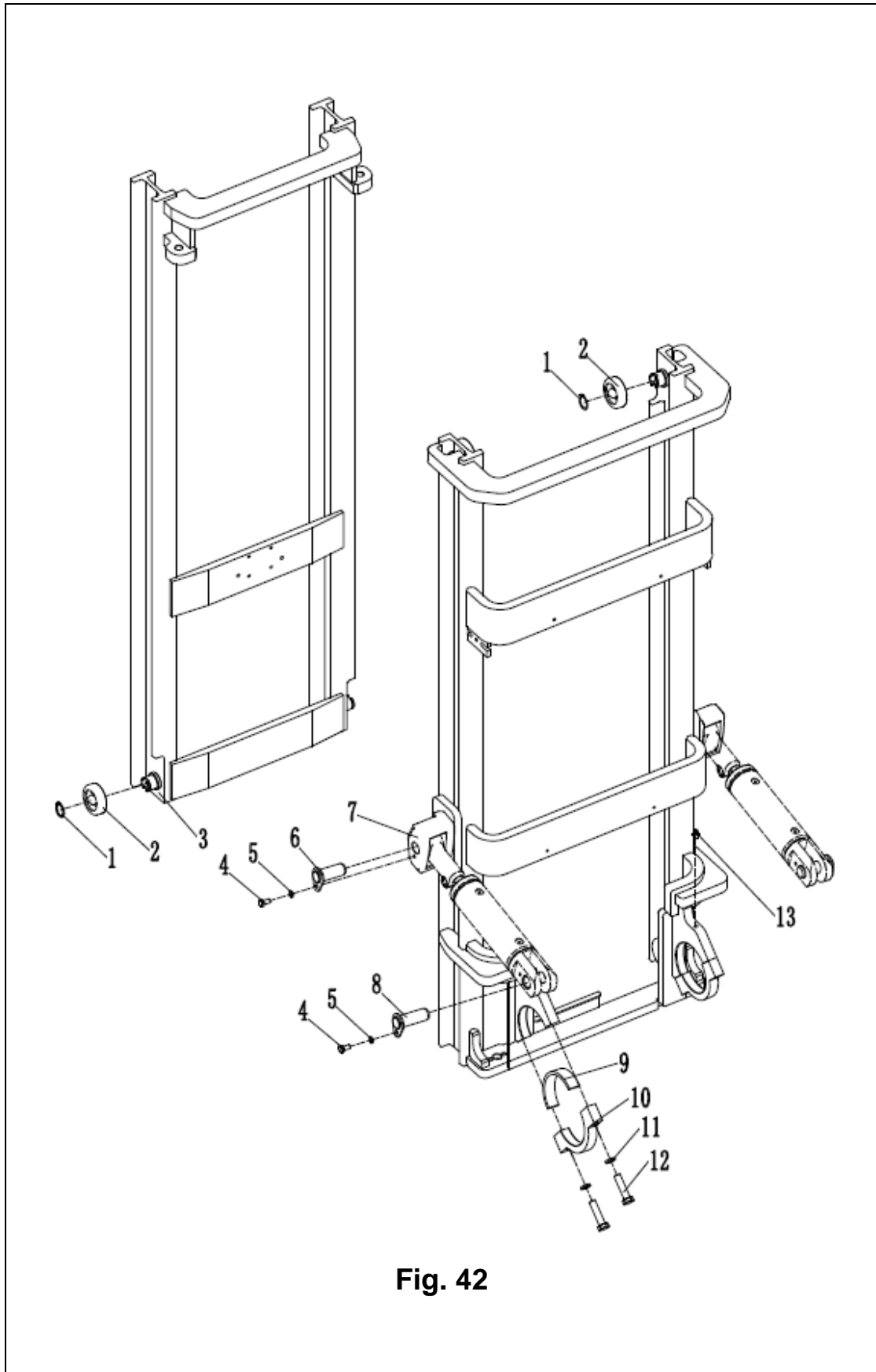

Fig. 42

Fig. 42 Mast (two stage full free)

No.	Coding	Description	Qty.	Note
1	910401300017	Circlip GB894.1-32	4	
2	940200300007	Roller ϕ 78.3-range=45.3-49.3	4	
3	254144010011	Mast 2500	1	H=2500
	254144010012	Mast 2700	1	H=2700
	254144010013	Mast 3000	1	H=3000
	254144010014	Mast 3300	1	H=3300
	254144010015	Mast 3500	1	H=3500
	254144010016	Mast 3700	1	H=3700
	254144010017	Mast 4000	1	H=4000
	254144010018	Mast 4300	1	H=4300
	254144010019	Mast 4500	1	H=4500
	254144010020	Mast 5000	1	H=5000
4	910100300035	Bolt GB5783-M10x20-8.8	4	
5	910400500007	Washer GB93-10	4	
6	253520510005	Axle ϕ 30x82	2	
7	254144010001	Mast 2500	1	H=2500
	254144010002	Mast 2700	1	H=2700
	254144010003	Mast 3000	1	H=3000
	254144010004	Mast 3300	1	H=3300
	254144010005	Mast 3500	1	H=3500
	254144010006	Mast 3700	1	H=3700
	254144010007	Mast4000	1	H=4000
	254144010008	Mast 4300	1	H=4300
	254144010009	Mast 4500	1	H=4500
	254144010010	Mast 5000	1	H=5000
8	253520510001	Axle ϕ 30x72	2	
9	253544020001	Bearing bush	2	
10	251044020065	Bearing cover	2	

Mast (two stage full free)

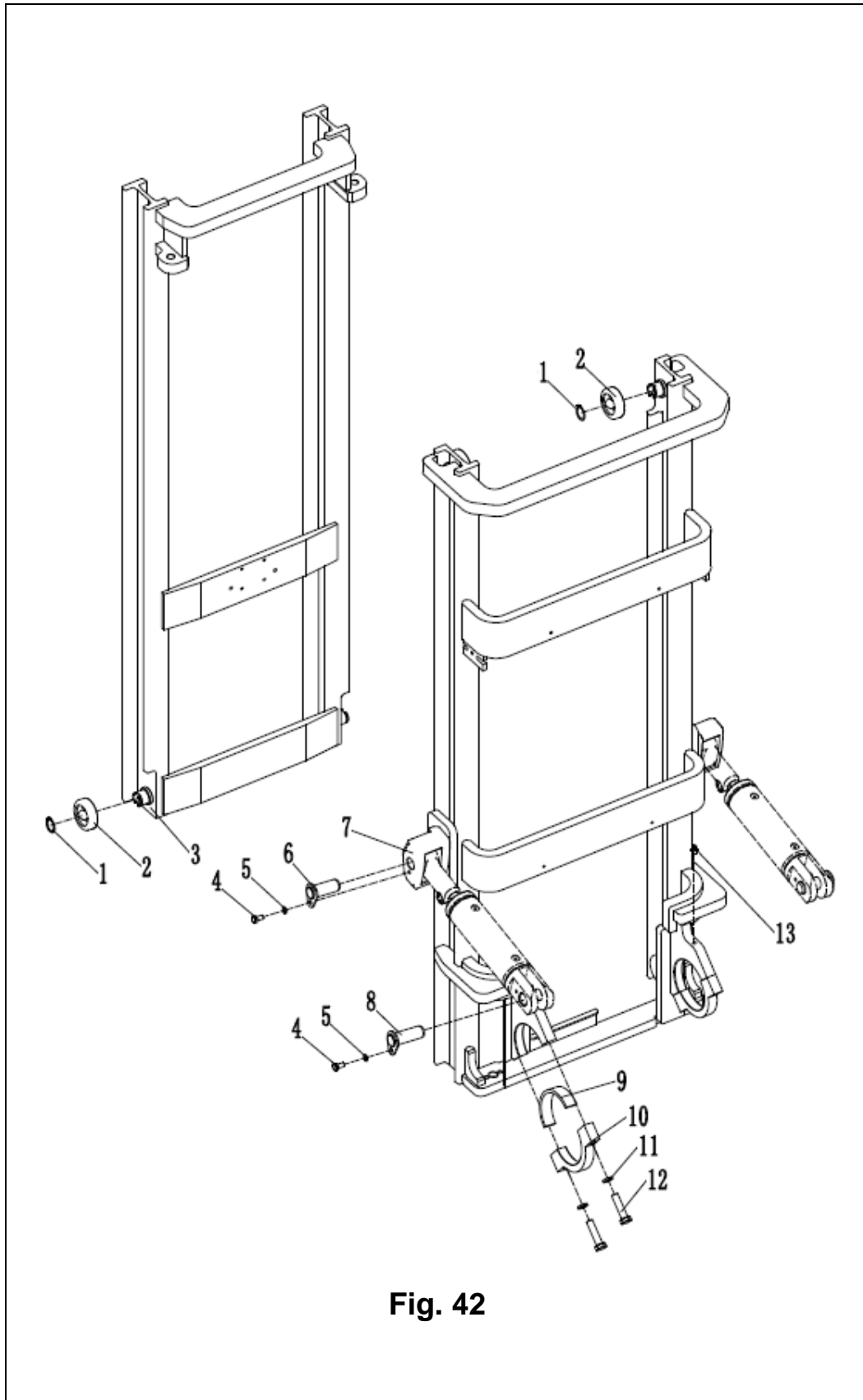

Fig. 42

Fig. 42 Mast (two stage full free)

No.	Coding	Description	Qty.	Note
11	910400500010	Washer GB93-16	4	
12	910100200016	Bolt GB5785-M16x1.5x70-8.8	4	
13	911200100004	Grease nipple JB7940.1-M10x1	2	

Mast (three stage full free)

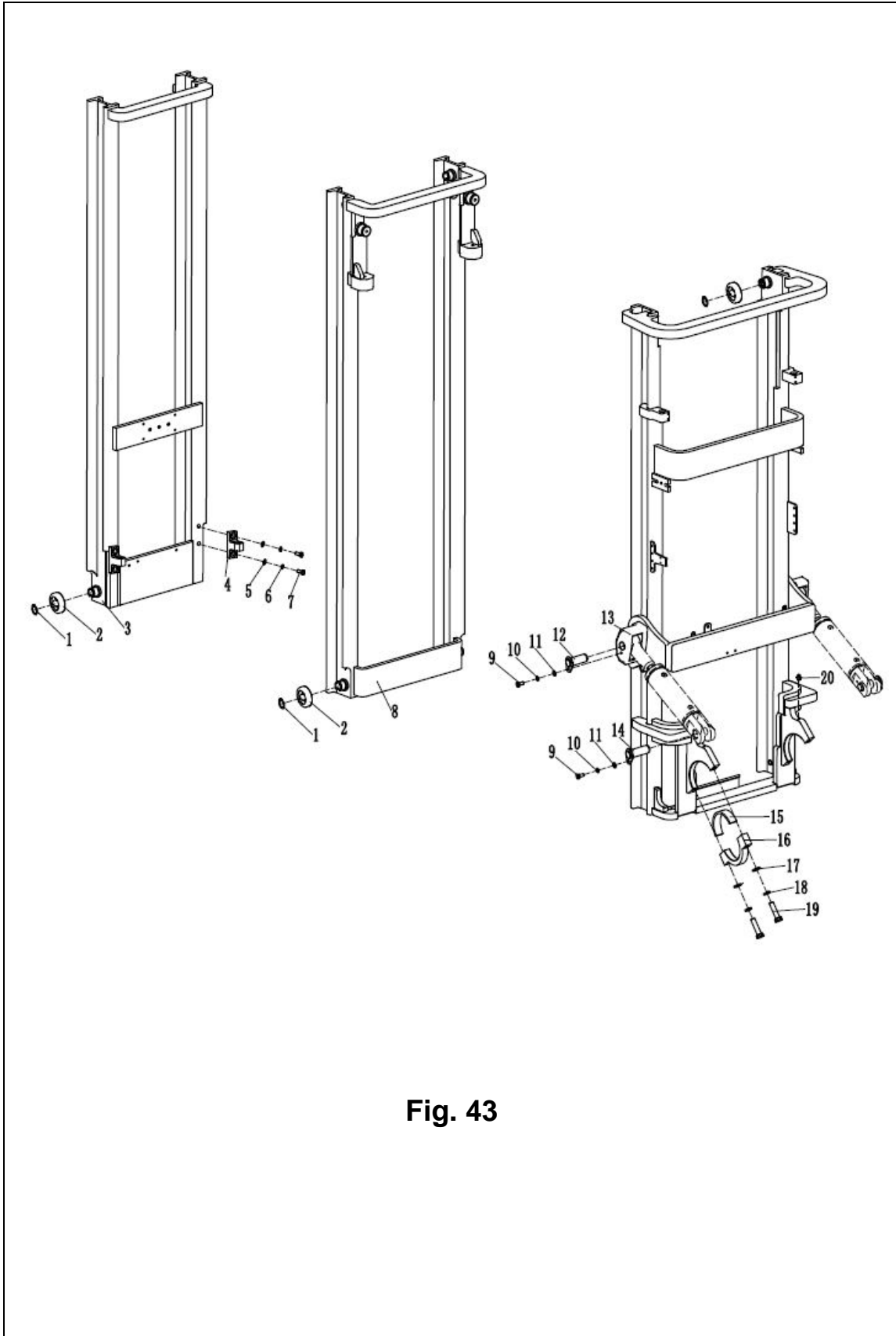

Fig. 43

Fig. 43 Mast (three stage full free)

No.	Coding	Description	Qty.	Note
1	910401300017	Circlip GB894.1-32	8	
2	940200300007	Roller ϕ 78.3-range=45.3-49.3	8	
3	254144510001	Mast 4000	1	H=4000
	254144510002	Mast 4350	1	H=4350
	254144510003	Mast 4500	1	H=4500
	254144510004	Mast 4800	1	H=4800
	254144510005	Mast 5000	1	H=5000
	254144510006	Mast 5500	1	H=5500
	254144510007	Mast 6000	1	H=6000
4	254144520030	Embrace hoop	2	
5	910400100010	Washer GB97.1-16200HV	4	
6	910400500010	Washer GB93-16	4	
7	910100400028	Bolt GB5786-M16x1.5 x35-8.8	4	
8	254144510023	Mast 4000	1	H=4000
	254144510024	Mast 4350	1	H=4350
	254144510025	Mast 4500	1	H=4500
	254144510026	Mast 4800	1	H=4800
	254144510027	Mast 5000	1	H=5000
	254144510028	Mast 5500	1	H=5500
	254144510029	Mast 6000	1	H=6000
9	910100300035	Bolt GB5783-M10x20-8.8	4	
10	910400500007	Washer GB93-10	4	
11	910400100007	Washer GB97.1-10-200HV	4	
12	253520510005	Axle ϕ 30x82	2	
13	254144510037	Mast4000	1	H=4000
	254144510038	Mast 4350	1	H=4350
	254144510039	Mast4500	1	H=4500
	254144510040	Mast4800	1	H=4800
	254144510041	Mast 5000	1	H=5000

Mast (three stage full free)

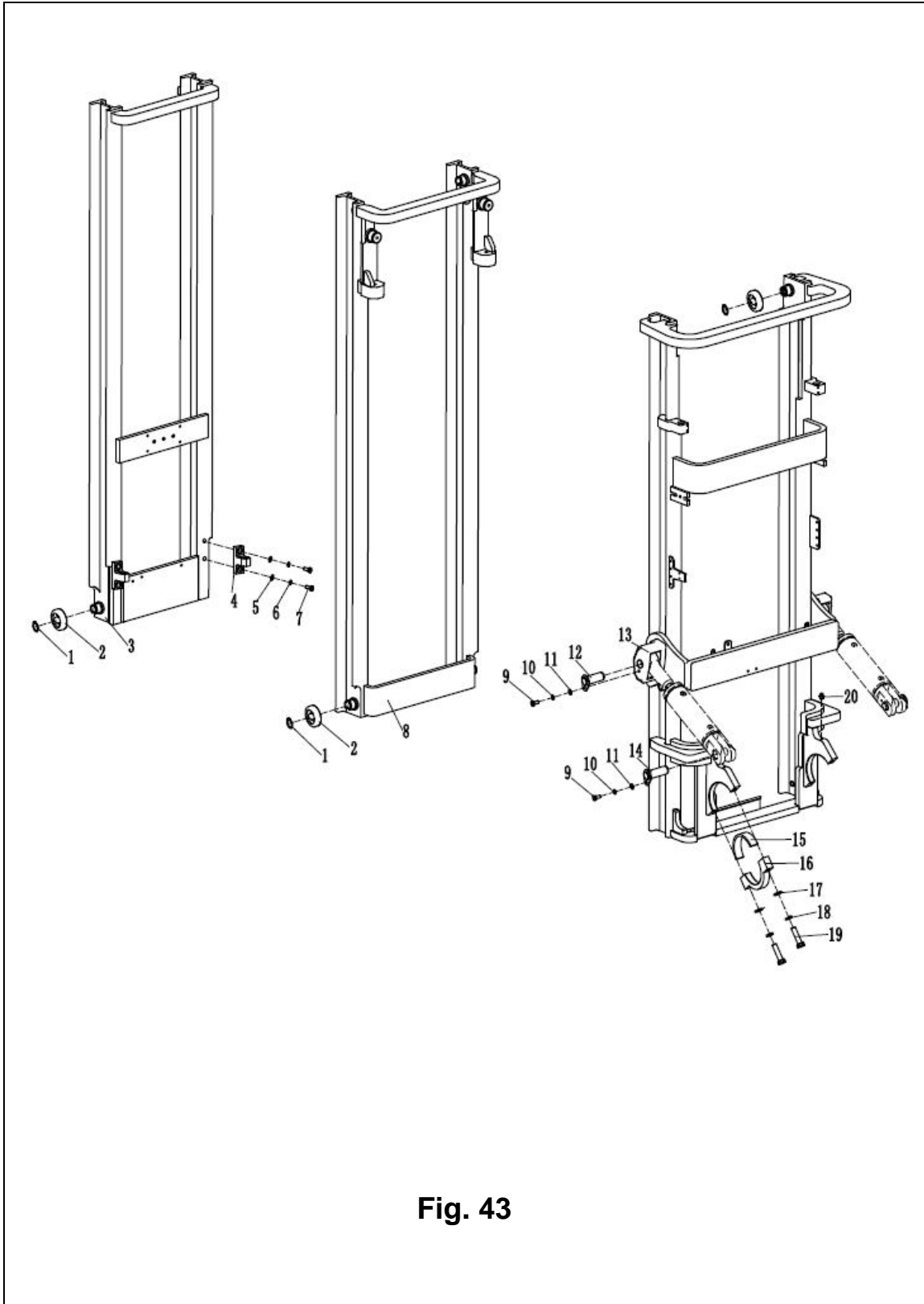

Fig. 43

Fig. 43 Mast (three stage full free)

No.	Coding	Description	Qty.	Note
13	254144510042	Mast 5500	1	H=5500
	254144510043	Mast 6000	1	H=6000
14	253520510001	Axle ϕ 30x72	2	
15	255044020006	Bearing bush	2	
16	255044020005	Bearing cover	2	
17	910400500010	Washer GB93-16	4	
18	910100200016	Bolt GB5785-M16x1.5x70-8.8	4	
19	910400100010	Washer GB97.1-16-200HV	4	
20	911200100004	Grease nipple JB7940.1-M10x1	2	

Lifting cylinder(standard mast)

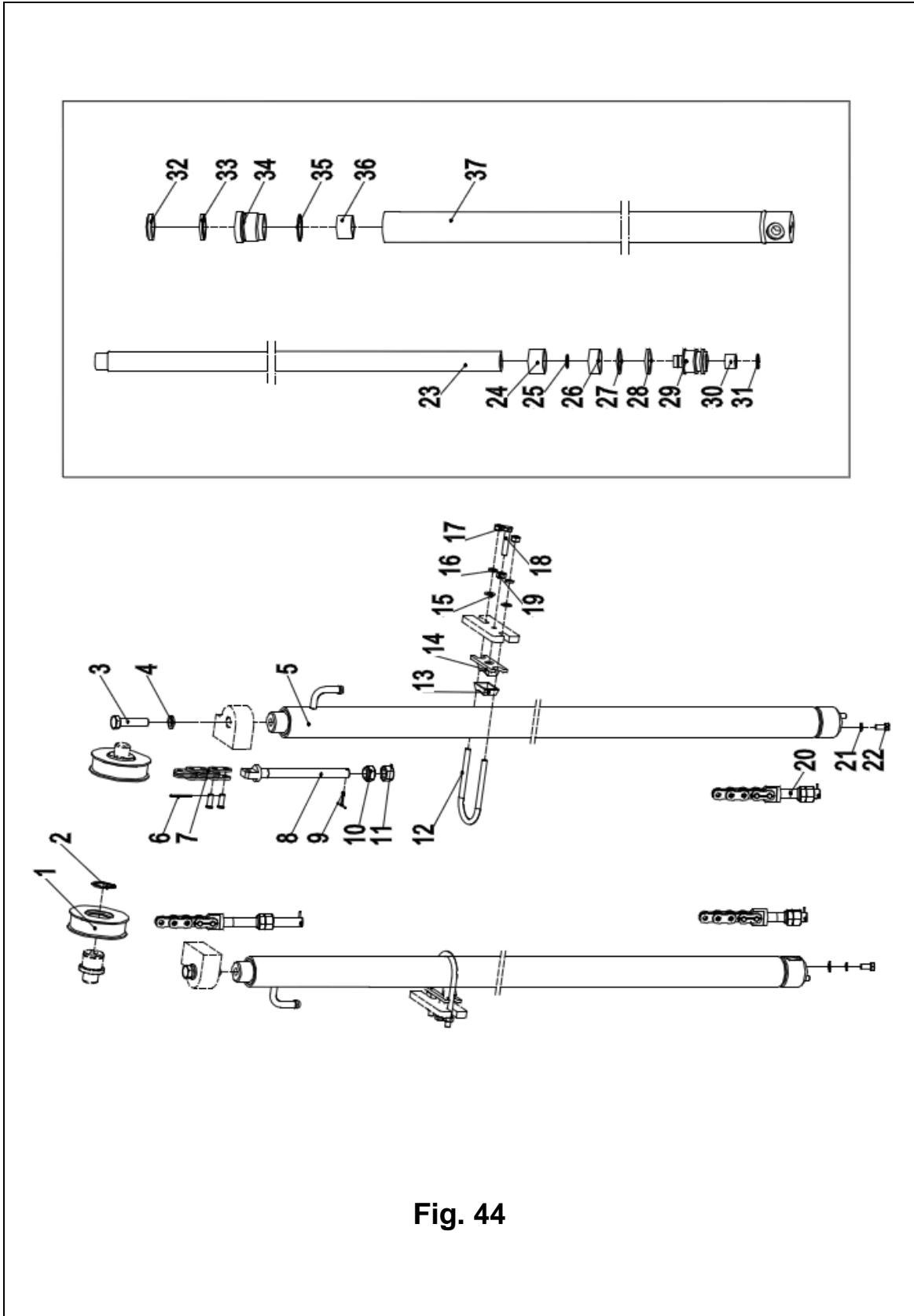

Fig. 44 Lifting cylinder(standard mast)

No.	Coding	Description	Qty.	Note
1	940200500003	Chain wheel bearing780706-φ72xφ30x21	2	
2	910401300020	Circlip GB894.1-40	2	
3	910100300051	Bolt GB5783-M12x35-8.8	4	
4	910400500008	Washer GB93-12	2	
5	254144010021	cylinder φ 45x φ 35x1246	2	H=2500
	254144010022	cylinder φ 45x φ 35x1346	2	H=2700
	254144010023	cylinder φ 45x φ 35x1496	2	H=3000
	254144010024	cylinder φ 45x φ 35x1646	2	H=3300
	254144010025	cylinder φ 45x φ 35x1746	2	H=3500
	254144010026	cylinder φ 45x φ 35x1846	2	H=3700
	254144010027	cylinder φ 45x φ 35x1996	2	H=4000
	254144010028	cylinder φ 45x φ 35x2146	2	H=4300
	254144010029	cylinder φ 45x φ 35x2246	2	H=4500
	254144010030	Cylinder φ 45x φ 35x2496	2	H=5000
6		Split pin 2x3	2	Belong to A▲
7		LH1223 chain	2	Belong to A▲
8		Joint	2	Belong to A▲
9		Split pin 3.2x30	2	Belong to A▲
10		Nut M16x1.5	2	Belong to A▲
11		Nut M16x1.5	2	Belong to A▲
12	254144020060	Fixing ring	2	
13	254144020061	shield	2	
14	254144020062	Fixing seat	2	
15	910400100006	Washer GB97.1-8-200HV	4	
16	910400500006	Washer GB93-8	4	

Note: Spare parts will not be provided separately

Lifting cylinder (standard mast)

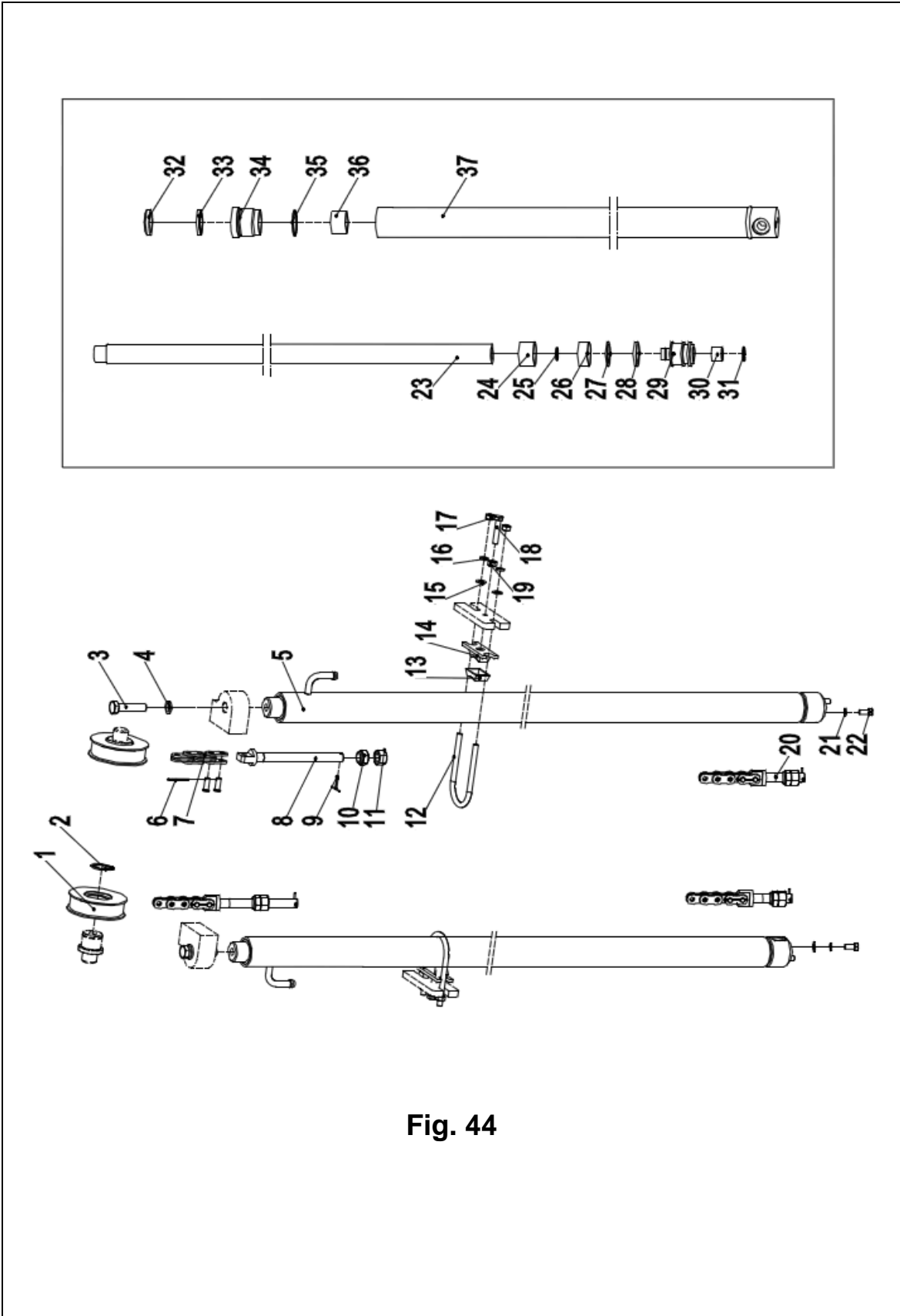

Fig. 44

Fig. 44 Lifting cylinder Lifting cylinder (standard mast)

No.	Coding	Description	Qty.	Note
17	910300100006	Nut GB6170-M8-10	4	
18	910300100007	Nut GB6170-M10-10	2	
19	910100300038	Bolt GB5783-M10x35-8.8	2	
20		Joint	2	Belong to A▲
21	910400500007	Washer GB93-10	6	
22	910100400002	Bolt GB5786-M10x1.25x20-8.8	2	
23		Piston rod	1	▲
24		Adjusting bushing ϕ 35.5x ϕ 44xL1	1	▲
25		Circlip	1	▲
26		Bearing D45x8(t=2.5)	1	▲
27		Catch35x45x3	1	▲
28		Seal ring 45x35x6	1	▲
29		Piston rod	1	▲
30		Copper bushing	1	▲
31		Circlip	1	▲
32		Dust ring35x47x7	1	▲
33		Seal ring 35x45x6	1	▲
34		Guide sleeve	1	▲
35		O ring 44.7x2.4	1	▲
36		Bearing 3530	1	▲
37		Cylinder	1	▲
38	254198510001	Seal kits(lifting cylinder)	2	Include 27.29.34.35.37

Note: Spare parts will not be provided seperately

Lifting cylinder (standard mast)

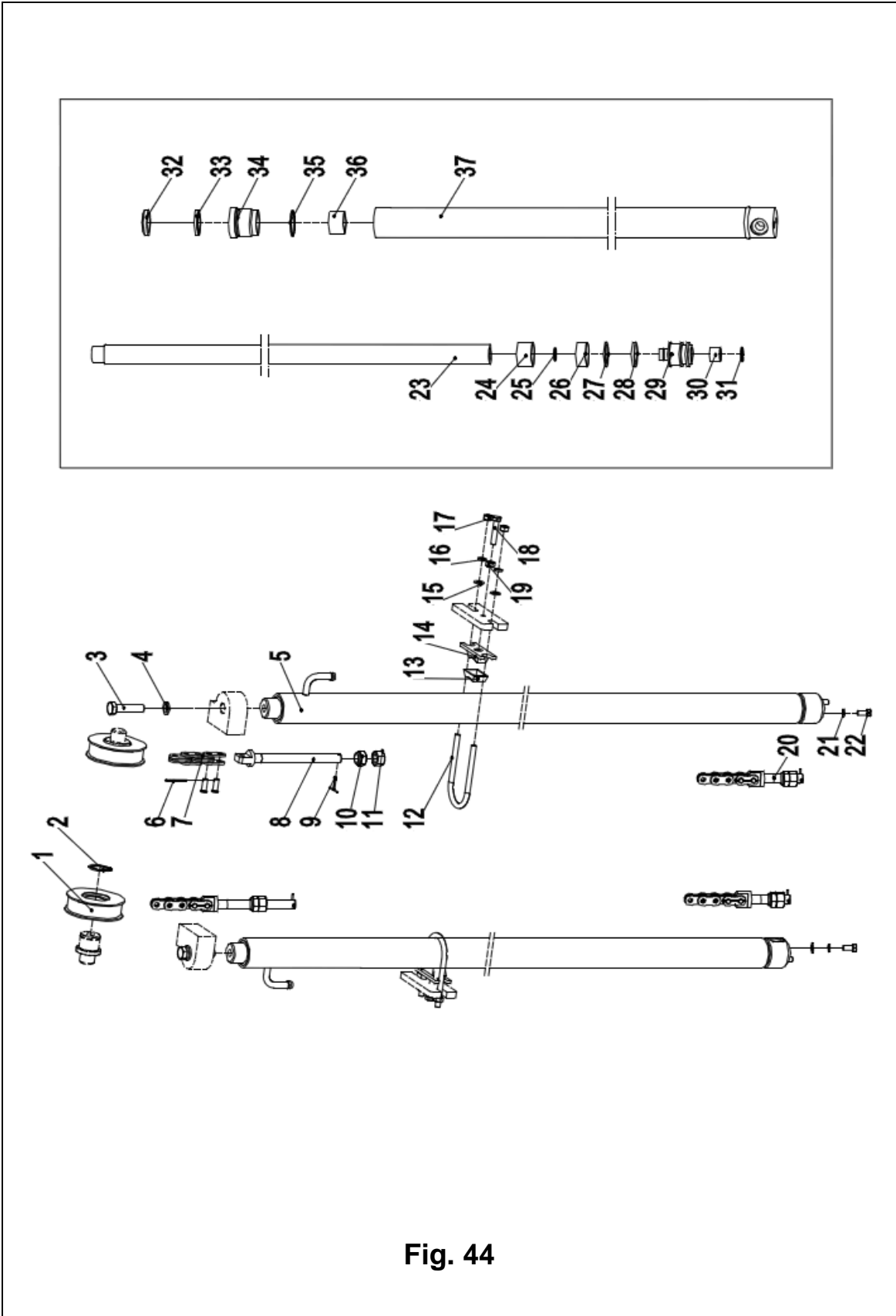

Fig. 44

Fig. 44 **Lifting cylinder (standard mast)**

No.	Coding	Description	Qty.	Note
A	254144010031	Lifting chain LH1223-89	2	H=2500
	251044510082	Lifting chain LH1223-95	2	H=2700
	251044510083	Lifting chain LH1223-103	2	H=3000
	251044510084	Lifting chain LH1223-111	2	H=3300
	251044010047	Lifting chain LH1223-115	2	H=3500
	254144010032	Lifting chain LH1223-121	2	H=3700
	254144010033	Lifting chain LH1223-139	2	H=4000
	284044010039	Lifting chain LH1223-147	2	H=4300
	254144010034	Lifting chain LH1223-153	2	H=4500
	254144010035	Lifting chain LH1223-169	2	H=5000

Note: Spare parts will not be provided seperately

Short lifting cylinder (two stage full free)

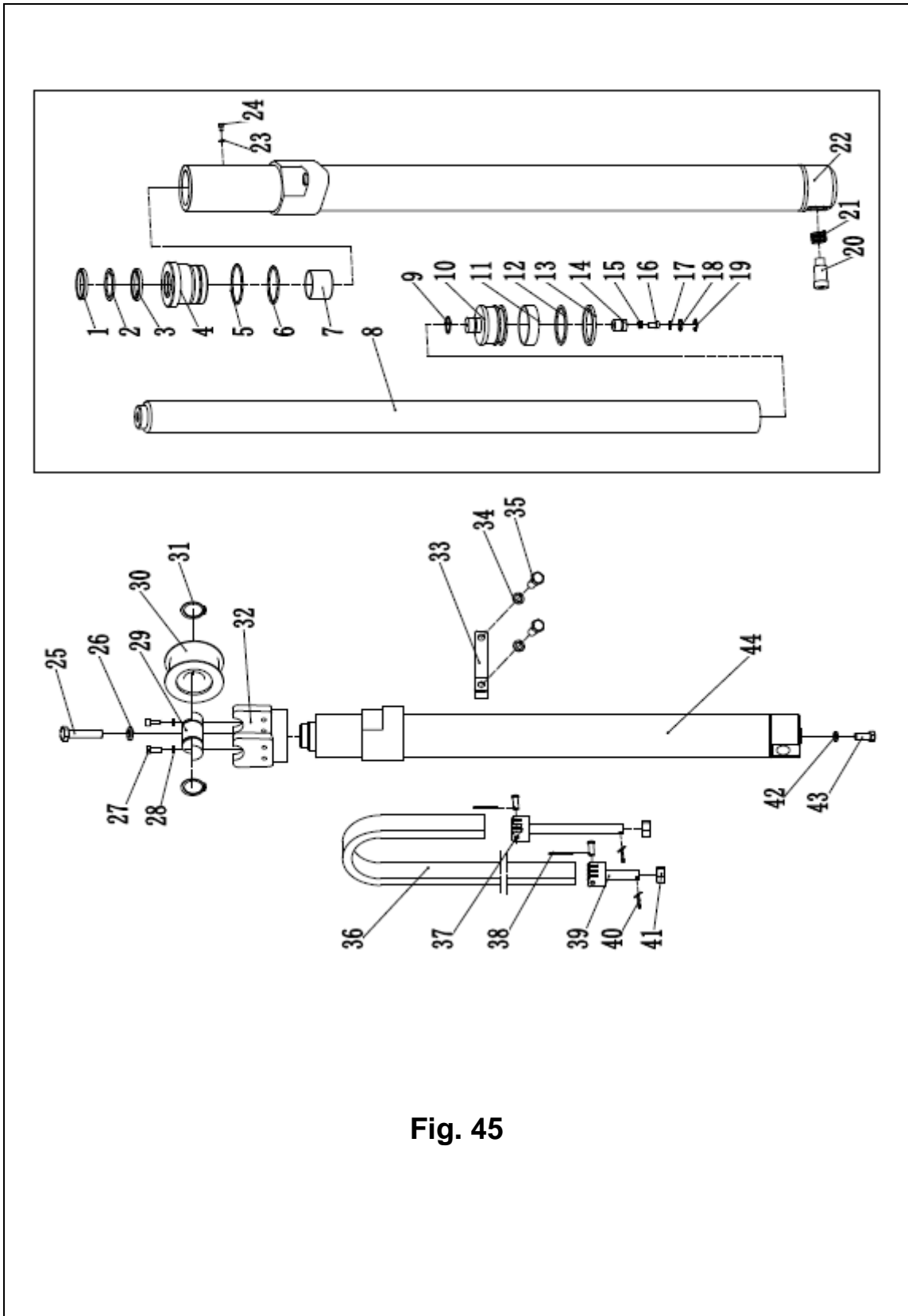

Fig. 45 Short lifting cylinder (two stage full free)

No.	Coding	Description	Qty.	Note
A	254143510060	Lifting chain LH1266-65	2	H=2500
	254143510061	Lifting chain LH1266-71	2	H=2700
	254143510062	Lifting chain LH1266-79	2	H=3000
	254143510063	Lifting chain LH1266-87	2	H=3300
	254143510064	Lifting chain LH1266-93	2	H=3500
	254143510065	Lifting chain LH1266-97	2	H=3700
	254143510066	Lifting chain LH1266-105	2	H=4000
	254143510067	Lifting chain LH1266-113	2	H=4300
	254143510068	Lifting chain LH1266-119	2	H=4500
	254143510069	Lifting chain LH1266-133	2	H=5000
1		Dust ring 50x58x7/6.5	1	▲
2		Catch 50x60x3	1	▲
3		Seal ring 50x60x6	1	▲
4		Guide sleeve	1	▲
5		O ring D75x3.1	1	▲
6		O ring D70x3.1	1	▲
7		Bearing 5035	1	▲
8		Piston rod	1	▲
9		Circlip	1	▲
10		Piston assembly	1	▲
11		Back up ring 70x20x3	1	▲
12		Circlip 70x60x3	1	▲
13		Seal ring 70x60x6	1	▲
14		Valve bushing	1	▲
15		Spring	1	▲
16		Valve plug	1	▲
17		O ring D20x2.4	1	▲
18		Circlip ϕ 12	1	▲
19		Circlip ϕ 22	1	▲
20		Slide valve	1	▲
21		Spring	1	▲
22		Cylinder	1	▲
23		Spacer	1	▲
24		Screw M5x5	1	▲

Note: Spare parts will not be provided separately

Short lifting cylinder (two stage full free)

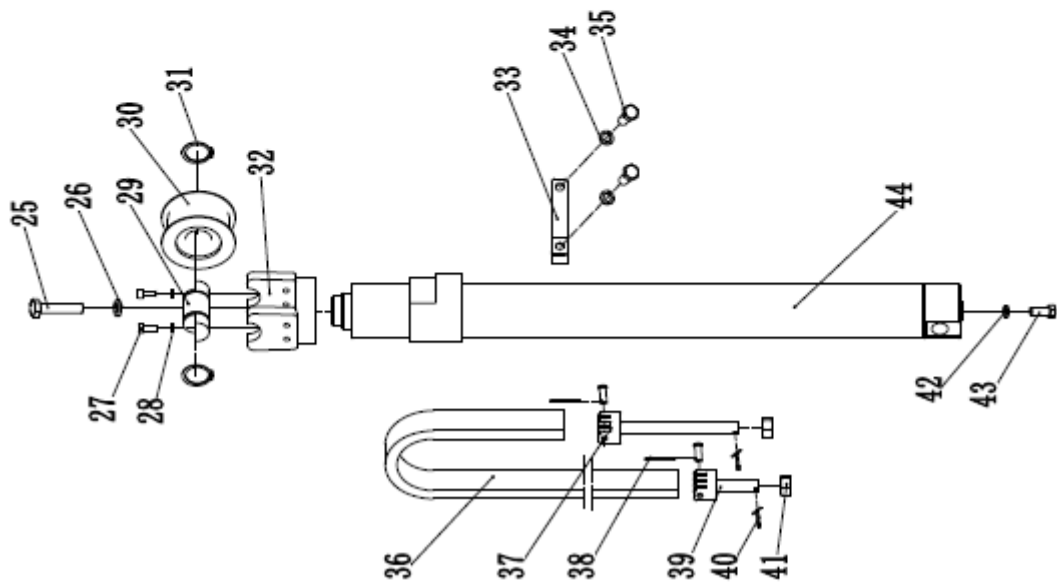
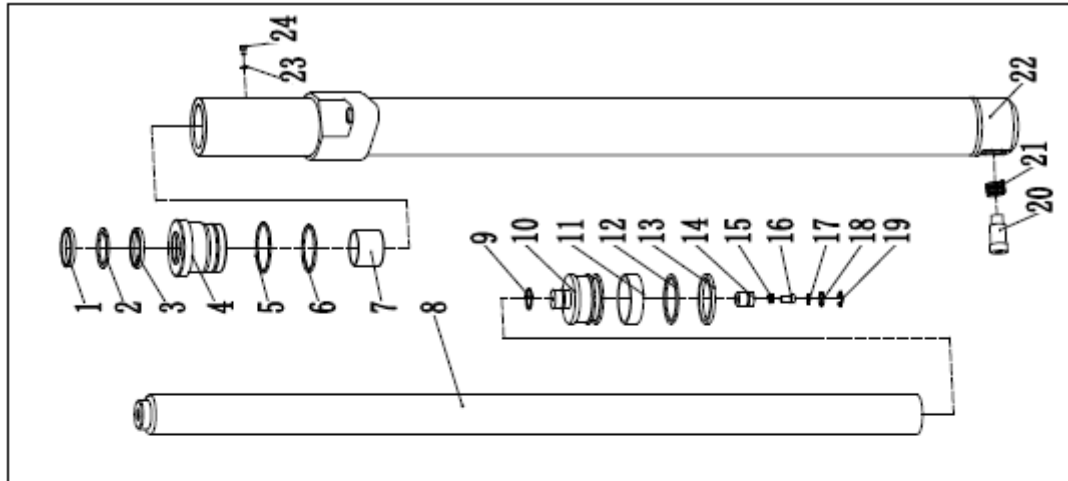

Fig. 45

Fig. 45 Short lifting cylinder (two stage full free)

No.	Coding	Description	Qty.	Note
25	910100800006	Bolt GB5789-M16x40-8.8	1	
26	910400500010	Washer GB93-16	1	
27	941100400001	Screw M8x20-8.8	2	
28	910400500006	Washer GB93-8	4	
29	254143520056	Chain wheel bearing	1	
30	940200500009	Chain wheel bearing 785208-00- ϕ 95x ϕ 40x ϕ 47	1	
31	910401300020	Circlip GB894.1-40	2	
32	254143510050	Chain wheel weld	1	
33	254143520072	Embrace hoop	1	
34	910400100006	Washer GB97.1-8-200HV	2	
35	910100300022	Bolt GB5783-M8x20-8.8	2	
36		LH1266 chain	1	Belong to A ▲
37	254143520070	Joint	1	Belong to A ▲
38		Split pin GB91-3.2x40	1	Belong to A ▲
39	254143520071	Joint	1	Belong to A ▲
40		Split pin 2.5X16	2	Belong to A ▲
41		Nut M18x1.5	2	Belong to A ▲
42	910400500008	Washer GB93-12	1	
43	910100400009	Bolt GB5786-M12x1.25x25-8.8	1	
44	254143510100	cylinder(M) ϕ 70x ϕ 55x630	1	Including No.1-24
	254143510101	cylinder(M) ϕ 70x ϕ 55x630	1	
	254143510102	cylinder(M) ϕ 70x ϕ 55x755	1	
	254143510103	cylinder(M) ϕ 70x ϕ 55x830	1	
	254143510104	cylinder (M) ϕ 70x ϕ 55x880	1	
	254143510105	cylinder (M) ϕ 70x ϕ 55x930	1	
	254143510106	cylinder (M) ϕ 70x ϕ 55x1005	1	
	254143510107	cylinder(M) ϕ 70x ϕ 55x1080	1	

Note: Spare parts will not be provided separately

Short lifting cylinder (two stage full free)

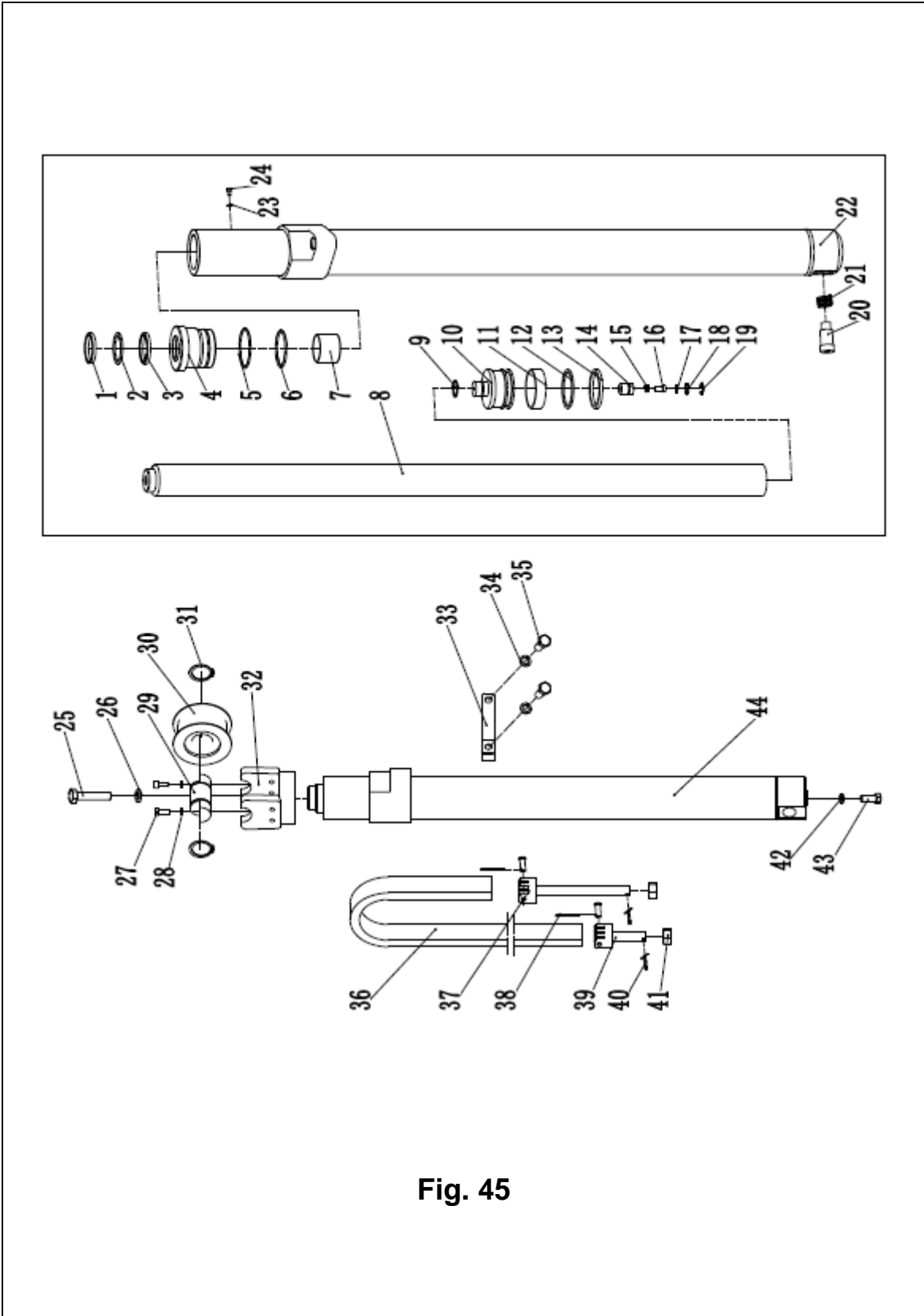

Fig. 45 Short lifting cylinder (two stage full free)

No.	Coding	Description	Qty.	Note
44	254143510108	cylinder $\Phi 70 \times \Phi 55 \times 1130$	1	Inc 1-24
	254143510109	cylinder $\Phi 70 \times \Phi 55 \times 1255$	1	
45	254198510002	Seal kits (middle cylinder)	1	Inc 1.3.5.6.13.18

Note: Spare parts will not be provided seperately

Lifting cylinder(two stage full free)

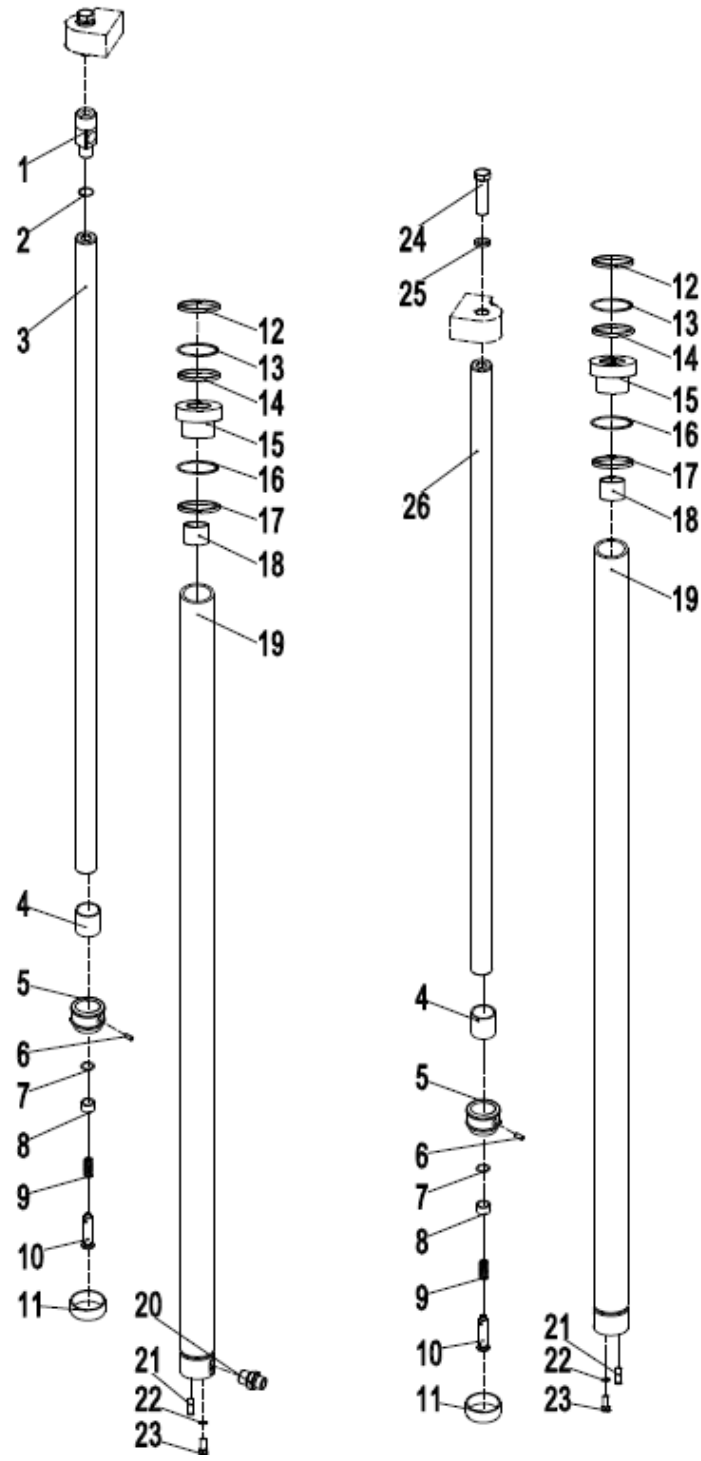

Fig. 46

Fig. 46 Lifting cylinder(two stage full free)

No.	Coding	Description	Qty.	Note
A	254143510120	cylinder (R) Φ 45x Φ 32x1225	1	Inc.1-21
	254143510121	cylinder (R) Φ 45x Φ 32x1325		
	254143510122	cylinder (R) Φ 45x Φ 32x1475		
	254143510123	cylinder (R) Φ 45x Φ 32x1625		
	254143510124	cylinder (R) Φ 45x Φ 32x1725		
	254143510125	cylinder (R) Φ 45x Φ 32x1825		
	254143510126	cylinder (R) Φ 45x Φ 32x1975		
	254143510127	cylinder (R) Φ 45x Φ 32x2125		
	254143510128	cylinder (R) Φ 45x Φ 32x2225		
	254143510129	cylinder (R) Φ 45x Φ 32x2475		
B	254143510110	cylinder (L) Φ 45x Φ 32x1225	1	Inc. 4-21.24
	254143510111	cylinder (L) Φ 45x Φ 32x1325		
	254143510112	cylinder (L) Φ 45x Φ 32x1475		
	254143510113	cylinder (L) Φ 45x Φ 32x1625		
	254143510114	cylinder (L) Φ 45x Φ 32x1725		
	254143510115	cylinder (L) Φ 45x Φ 32x1825		
	254143510116	cylinder (L) Φ 45x Φ 32x1975		
	254143510117	cylinder (L) Φ 45x Φ 32x2125		
	254143510118	cylinder (L) Φ 45x Φ 32x2225		
	254143510119	cylinder (L) Φ 45x Φ 32x2475		
1		Connecting rod	1	▲
2		O ring 26x2.4	1	▲
3		Piston rod assembly	1	▲
4		Adjusting bushing	2	▲
5		Piston	2	▲
6		ScrewM4x6	2	▲
7		Circlip ϕ 18	2	▲
8		Copper bushing	2	▲
9		Spring	2	▲
10		Buffer plunger	2	▲
11		Supporting ring45x15x2.5	2	▲

Note: Spare parts will not be provided seperately

Lifting cylinder(two stage full free)

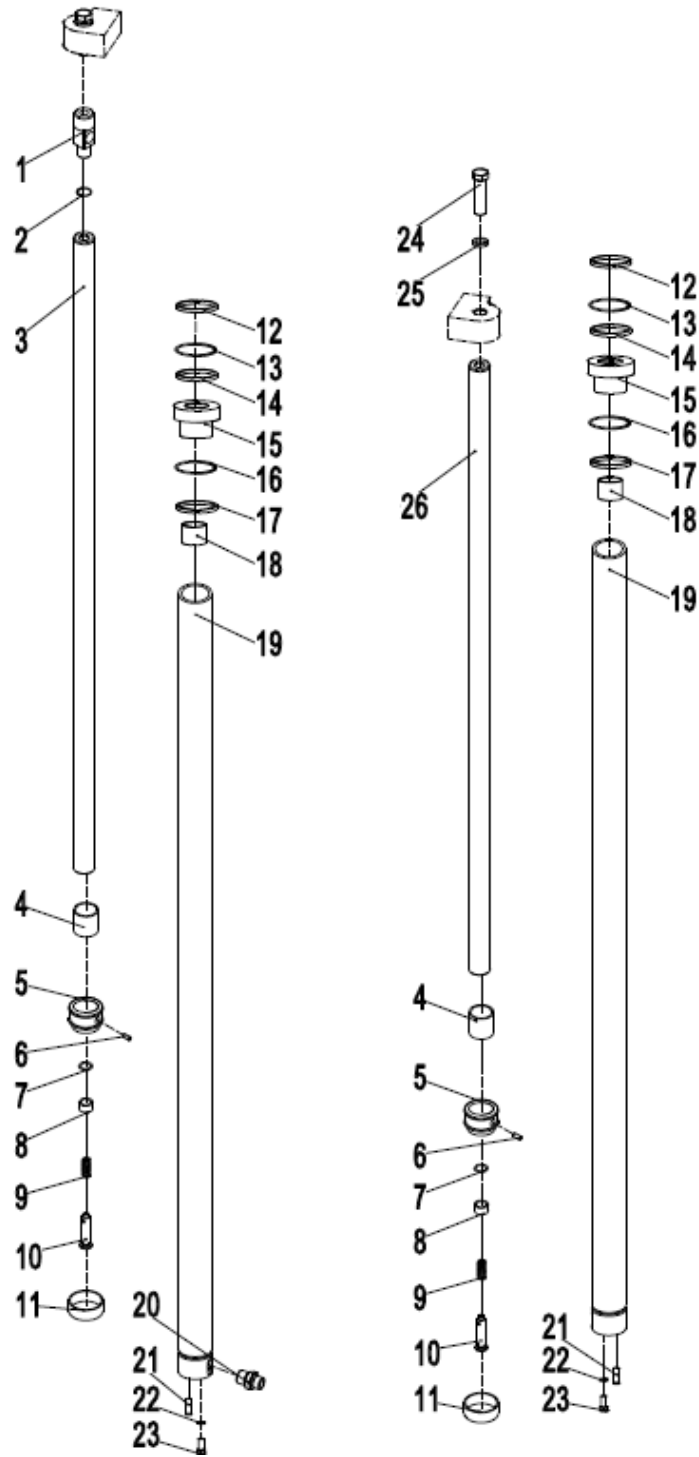

Fig. 46

Fig. 46 Lifting cylinder(two stage full free)

No.	Coding	Description	Qty.	Note
12		LBH Dust ring 32x40x5/6.5	2	▲
13		Catch 32x42x3	2	▲
14		Seal ring 40x50x6	2	▲
15		Guide bushing	2	▲
16		Catch 45x50x1.5	2	▲
17		O ring 50x3.1	2	▲
18		Bearing3230	2	▲
19		Cylinder	2	▲
20		Anti-explosion valve PF3/8-M18x1.5	1	▲
21		Dowel pin10x26	2	▲
22	910400500008	Washer GB93-12	2	
23	910100400009	Bolt GB5786-M12x1.25x25-8.8	2	
24	910100400029	Bolt GB5786-M16x1.5x40-8.8	1	
25	910400500010	Washer GB93-16	1	
26		Plunger rod assembly	1	▲
27	254198510001	Seal kits (lifting cylinder)	2	Inc 2.12.13.16

Note: Spare parts will not be provided seperately

Short lifting cylinder (three stage full free)

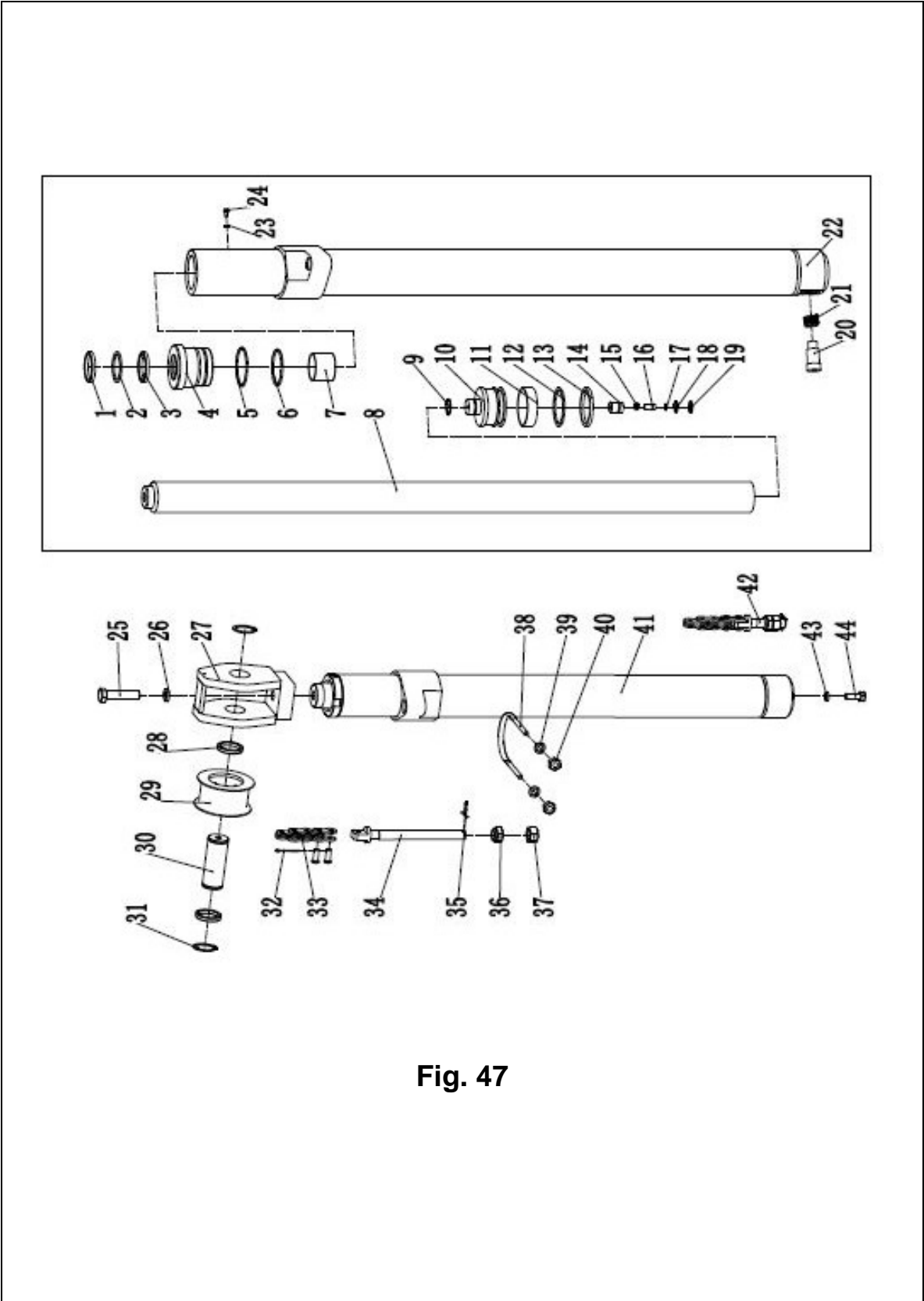

Fig. 47

Fig. 47 Short lifting cylinder (three stage full free)

No.	Coding	Description	Qty.	Note
A	254144510014	Lifting chain LH1266-71	2	H=4000
	254144510015	Lifting chain LH1266-73	2	H=4350
	254144510016	Lifting chain LH1266-75	2	H=4500
	254144510017	Lifting chain LH1266-77	2	H=4800
	254143510062	Lifting chain LH1266-79	2	H=5000
	254144510018	Lifting chain LH1266-83	2	H=5500
	254144510019	Lifting chain LH1266-89	2	H=6000
1		Dust ring 50x58x7/6.5	1	▲
2		Catch 50×60×3	1	▲
3		Seal ring 50×60×6	1	▲
4		Glide sleeve	1	▲
5		O ring D75X3.1	1	▲
6		O ring D75X3.1	1	▲
7		Bearing5035	1	▲
8		Piston rod	1	▲
9		Circlip	1	▲
10		Piston assembly	1	▲
11		Support ring 70x20x3	1	▲
12		Catch 70x60x3	1	▲
13		Seal ring 70x60x6	1	▲
14		Valve cover	1	▲
15		Spring	1	▲
16		Valve plug	1	▲
17		Catch	1	▲
18		O ring D20x2.4	1	▲
19		Circlip 22(inport)	1	▲
20		Slide valve	1	▲
21		Spring2.3x15x48.5	1	▲
22		Cylinder	1	▲
23		Spacer	1	▲
24		Screw M5x5	1	▲
25	910200200123	Screw GB70.1-M16x50-8.8	1	
26	910400500010	SpringWasherGB93-16	1	

Note: Spare parts will not be provided separately

Short lifting cylinder (three stage full free)

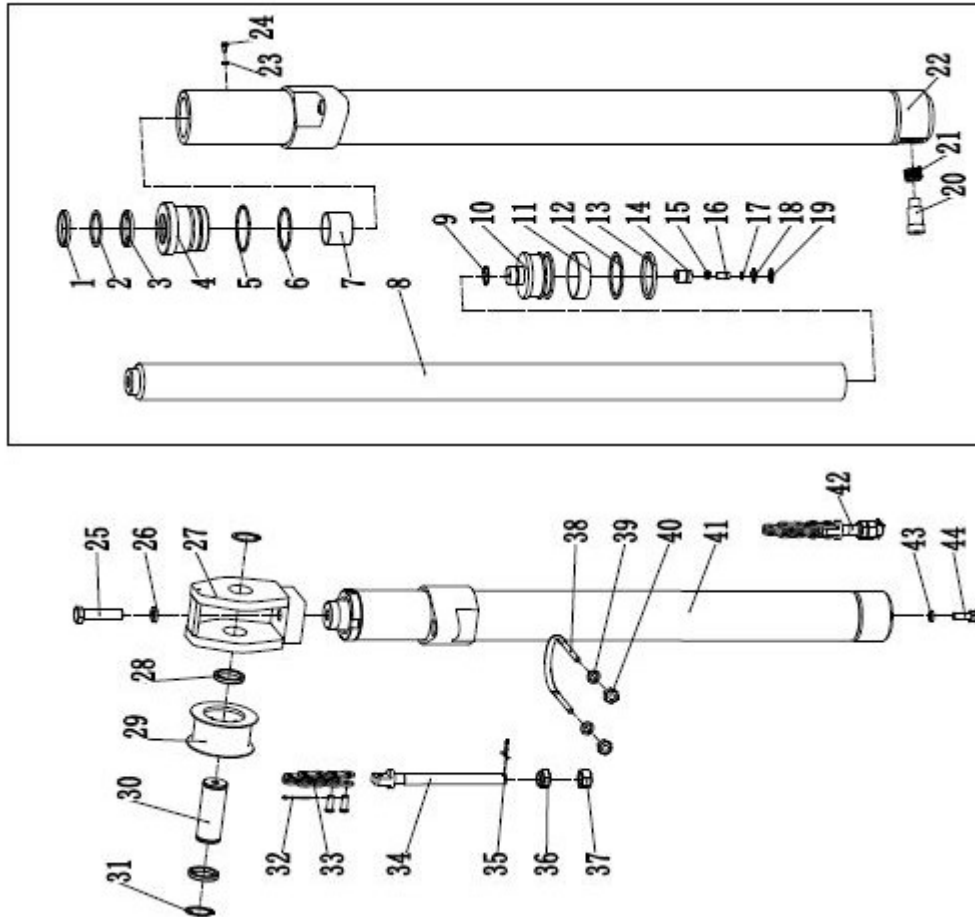

Fig. 47

Fig. 47 Short lifting cylinder (three stage full free)

No.	Coding	Description	Qty.	Note
27	254144510020	Chain wheel base	1	
28	254144520029	Chain wheel washer	1	
29	940200500009	Chain wheel bearing 785208-00- ϕ 95x ϕ 40x47	1	
30	254144520031	Chain wheel bearing	2	
31	910401300020	Circlip GB894.1-40	2	
32		split pin 2.5x40	2	Belong to A ▲
33		LH1266 chain	2	Belong to A ▲
34	254143520070	Joint	2	Belong to A ▲
35		Split pin 3.2x30	2	Belong to A ▲
36		Nut M18x1.5	2	Belong to A ▲
37		Nut M18x1.5	2	Belong to A ▲
38	254144520032	Hydro cylinder fixed loop	2	
39	910400500006	Spring Washer GB93-8	2	
40	910300100006	Bolt GB6170-M8-10		
41	255044510050	Short lifting cylinder H=4000	1	Inc. 1-24
	255044510051	Short lifting cylinder H=4300	1	
	255044510052	Short lifting cylinder H=4500	1	
	255044510053	Short lifting cylinder H=4800	1	
	255044510054	Short lifting cylinder H=5000	1	
	255044510055	Short lifting cylinder H=5500	1	
	255044510056	Short lifting cylinder H=6000	1	
42	254143520071	Joint	2	Belong to A ▲
43	910400500008	Spring Washer GB93-12	1	
44	910100400009	Bolt GB5786-M12x1.25x25-8.8	1	
45	255098510002	Seal kits (middle cylinder)	1	Inc. 1.3.5.6.13.18

Note: Spare parts will not be provided separately

Lifting cylinder(three stage full free)

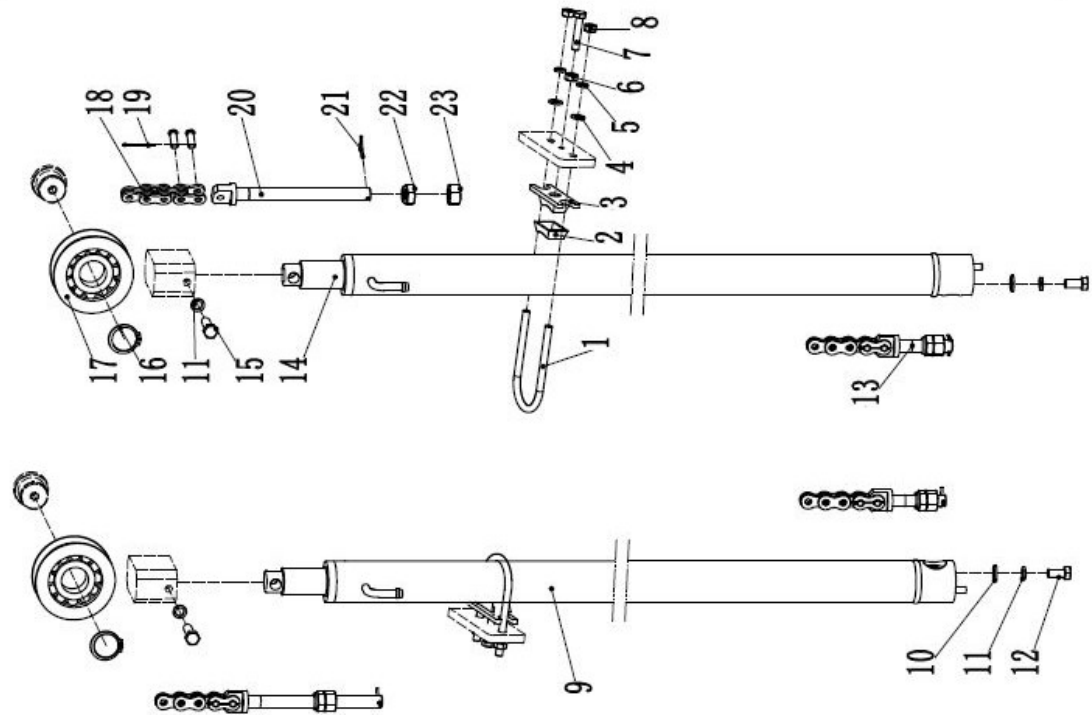
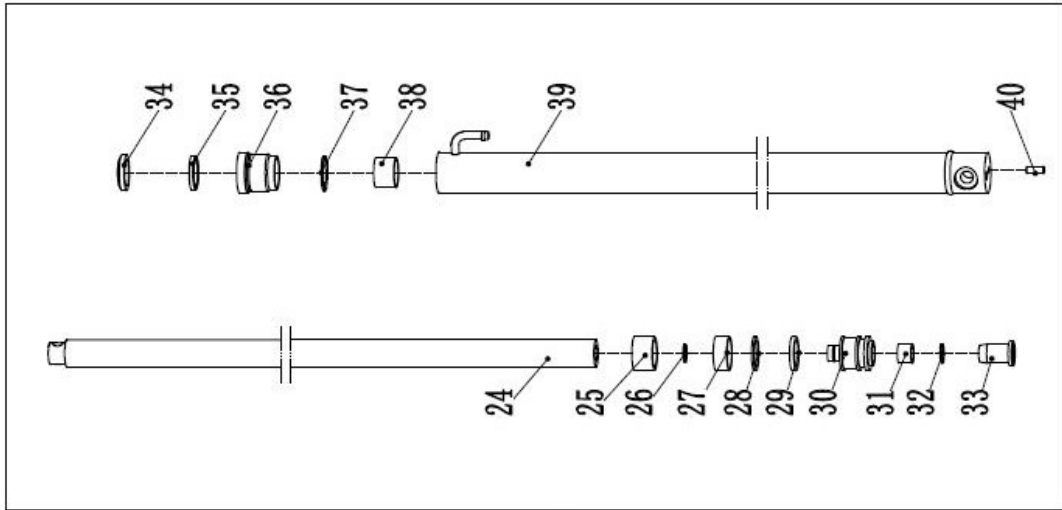

Fig. 48

Fig. 48 Lifting cylinder(three stage full free)

No.	Coding	Description	Qty.	Note
1	254144020060	Fasten loop	2	
2	254144020061	Shield	2	
3	254144020062	Fasten base	2	
4	910400100006	Washer GB97.1-8-200HV	4	
5	910400500006	Washer GB93-8	4	
6	910300100006	Nut GB6170-M8-10	4	
7	910300100007	Nut GB6170-M10-10	2	
8	910100300038	Bolt GB5783-M10x35-8.8	2	
9	254144510044	Left lifting cylinder H=4000	1	Inc 24-40
	254144510045	Left lifting cylinder H=4350	1	
	254144510046	Left lifting cylinder H=4500	1	
	254144510047	Left lifting cylinder H=4800	1	
	254144510048	Left lifting cylinder H=5000	1	
	254144510049	Left lifting cylinder H=5500	1	
	254144510050	Left lifting cylinder H=6000	1	
10	910400100008	Washer GB97.1-12-200HV	2	
11	910400500008	Washer GB93-12	4	
12	910100400009	Bolt GB5786-M12x1.25x25-8.8	2	
13	251044020064	Chain bolt	2	Belong to A▲
14	254144510051	Right lifting cylinder H=4000	1	Inc 24-40
	254144510052	Right lifting cylinder H=4300	1	
	254144510053	Right lifting cylinder H=4500	1	
	254144510054	Right lifting cylinder H=4800	1	
	254144510055	Right lifting cylinder H=5000	1	
	254144510056	Right lifting cylinder H=5500	1	
	254144510057	Right lifting cylinder H=6000	1	
15	910100300053	Bolt GB5783-M12x45-8.8	2	
16	910401300020	Circlip GB894.1-40	2	
17	940200500003	Chain wheel bearing 780708K-φ72xφ30x21	2	

Note: Spare parts will not be provided separately

Lifting cylinder (three stage full free)

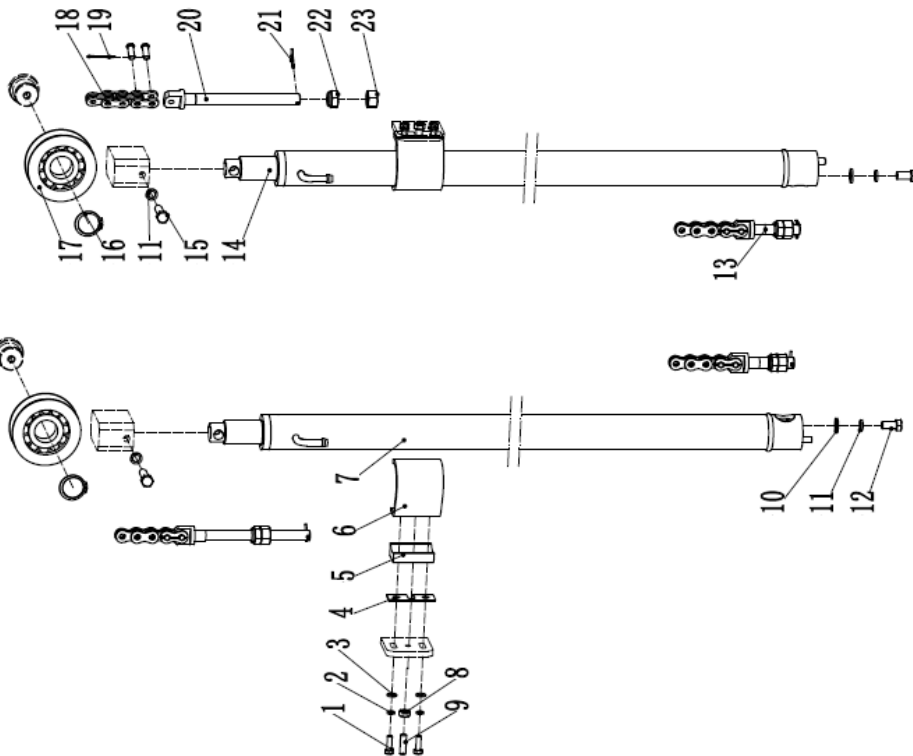
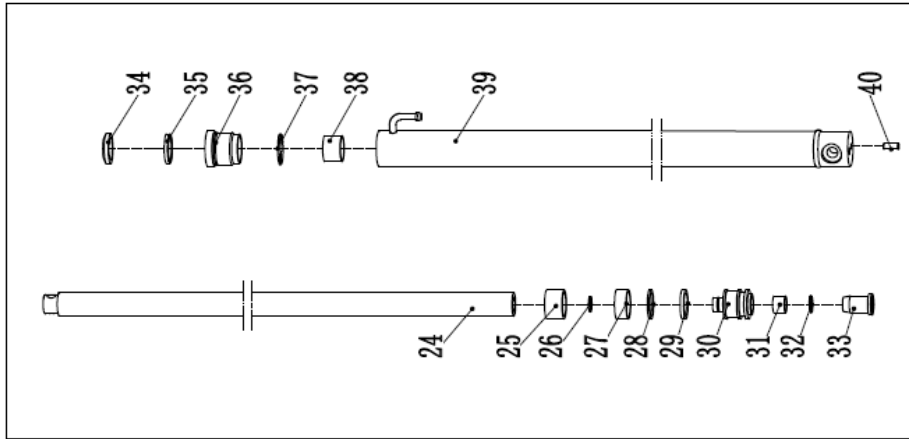

Fig. 48

Fig. 48 Lifting cylinder (three stage full free)

No.	Coding	Description	Qty.	Note
18		LH1223 chain	2	Belong to A ▲
19		Split pin 2x32	2	Belong to A ▲
20	251044020064	Chain bolt M16x1.5-90	2	Belong to A ▲
21		Split pin 3.2x30	2	Belong to A ▲
22		Nut M16x1.5	2	Belong to A ▲
23		Nut M16x1.5	2	Belong to A ▲
24		Piston rod	1	▲
25		Adjusting bushing 35.5x44xL1	1	▲
26		Circlip	1	▲
27		Bearing ring D45X8 (t=2.5)	1	▲
28		Catch 35x45x6	1	▲
29		Seal ring 45x35x6	1	▲
30		Piston	1	▲
31		Copper bushing	1	▲
32		Circlip		▲
33		Buffer ring	1	▲
34		Dust ring 35x47x7	1	▲
35		Seal ring 35x45x6	1	▲
36		Guide bushing	1	▲
37		O seal ring 44.7X2.4	1	▲
38		Bearing 3530	1	▲
39		Cylinder	1	▲
40		Dowel pin D10x26	1	▲
41	254198510001	Seal kits(lifting cylinder)	2	Inc.27.29.34.35.37
A	216544510074	Lifting chain LH1223-89	2	H=4000
	251043510082	Lifting chain LH1223-101	2	H=4350
	251044010072	Lifting chain LH1223-107	2	H=4500
	251044510092	Lifting chain LH1223-117	2	H=4800
	254144510008	Lifting chain LH1223-129	2	H=5000
	254144510009	Lifting chain LH1223-143	2	H=5500
	254144510010	Lifting chain LH1223-165	2	H=6000

Note: Spare parts will not be provided separately

Tilted cylinder

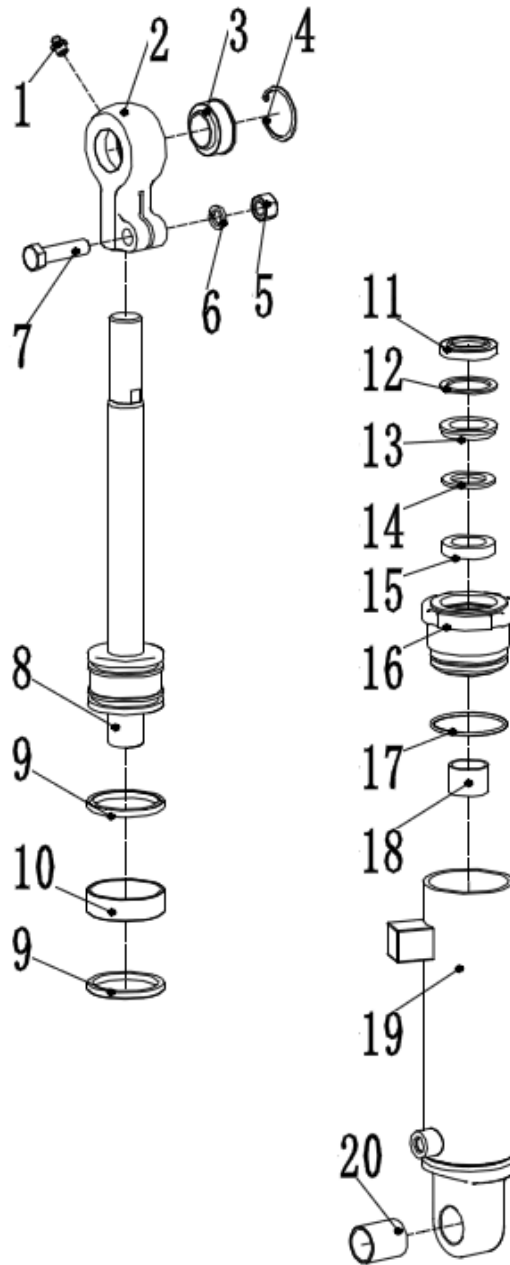

Fig. 49

Fig. 49**Tilted cylinder**

No.	Coding	Description	Qty.	Note
A	254120510001	Cylinder(TL) Φ 63x Φ 30x118(6/10)	1	Inc. 1-20
	254120510002	Cylinder (TL) Φ 63x Φ 30x88(6/6)	1	
	254120510003	Cylinder (TL) Φ 63x Φ 30x67(3/6)	1	
	254120510004	Cylinder (TL) Φ 63x Φ 30x45(3/3)	1	
B	254120510005	Cylinder (TL) Φ 63x Φ 30x118(6/10)	1	Inc. 1-20
	254120510006	Cylinder (TL) Φ 63x Φ 30x88(6/6)	1	
	254120510007	Cylinder (TL) Φ 63x Φ 30x67(3/6)	1	
	254120510008	Cylinder (TL) Φ 63x Φ 30x45(3/3)	1	
1		Grease mouth Z1/8	2	▲
2	254198520501	Earring	2	
3		Bearing GE30ES	2	▲
4		Circlip 47	2	▲
5		NutM14	2	▲
6		Washer14	2	▲
7		BoltM14x55	2	▲
8		Piston body assembly	2	▲
9		Yx seal ring D63x60x6	2	▲
10		Support ring D60x20x2.5	2	▲
11		Dust ring 52x30x8/9	2	▲
12		Circlip 52	2	
13		Circlip	2	▲
14		Catch 48x30x3	2	▲
15		Useal ring 48x30x10	2	▲
16		Guide sleeve	2	▲
17		O seal ring 63x3.1	2	▲
18		Bearing 3025	2	▲
19		Cylinder barrel assembly	2	▲
20		Bearing 3040	2	▲
C	254198510003	Seal kits (tilted cylinder)	2	Inc.9-11 .15.17

Note: Spare parts will not be provided separately

Electric system

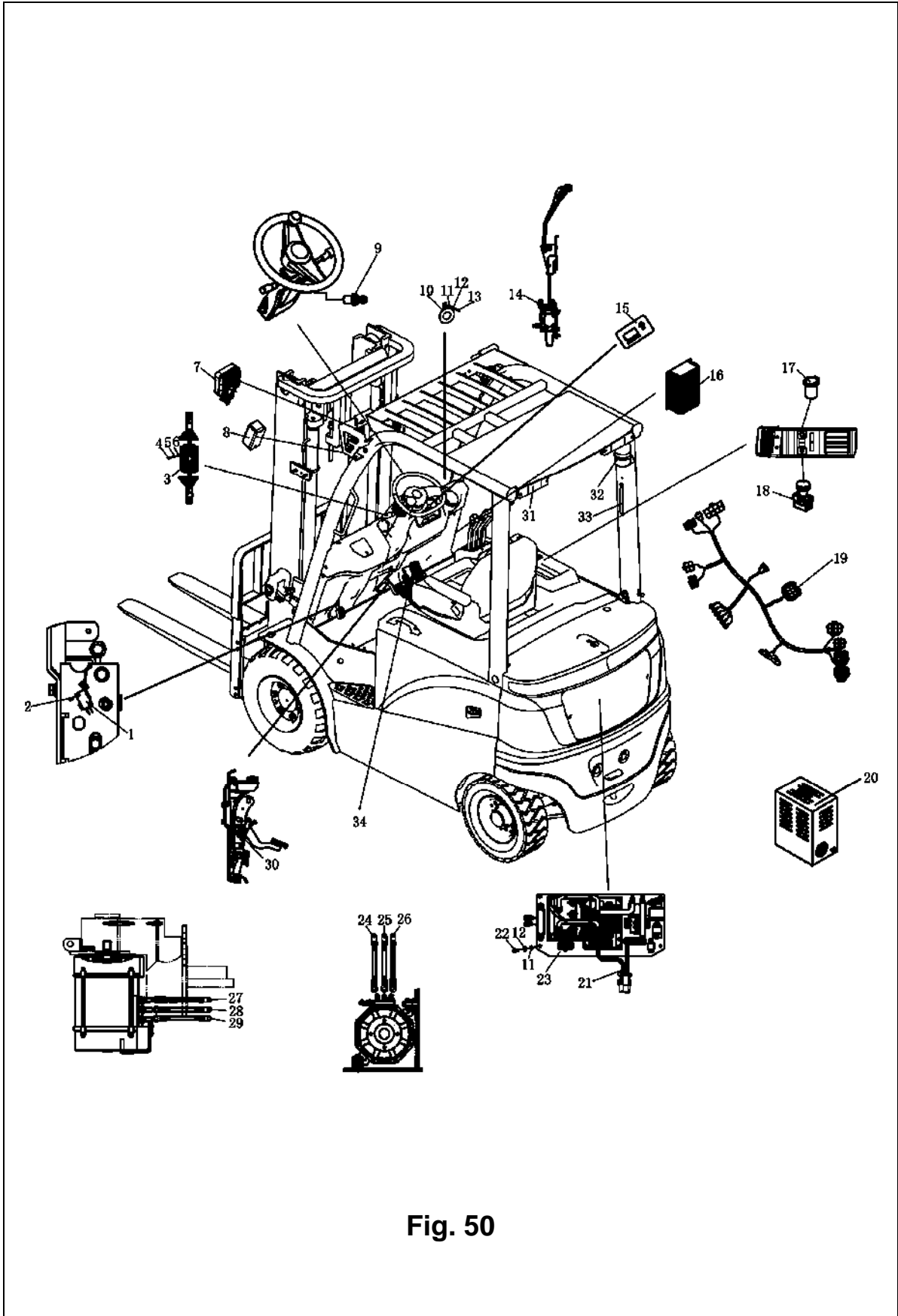

Fig. 50

Fig. 50**Electric system**

No.	Coding	Description	Qty.	Note
1	920200300009	Micro switch RV-166-1C25	1	
2	910400100003	Washer GB97.1-4-200HV	2	
3	920200800013	Combination switch JK361B-1003	1	
4	910200500038	Screw GB818-M5x12-4.8	4	
5	910400500004	Washer GB93-5	8	
6	910400100004	Washer GB97.1-5-200HV	8	
7	922000100001	Light PDL-LXZM-1	2	
8	922000100002	Light PDL-LXXD-1	2	
9	920200200002	Key switch KEYA	1	
10	920500100001	Horn 125-DC24V	1	
11	910400100005	Washer GB97.1-6-200HV	1	
12	910400500005	Washer GB93-6	1	
13	910200500051	Screw GB818-M6x12-4.8	1	
14	920200300004	Micro switch RZ-15GQ22-B3	3	
15	921100100011	Indicator 3501-12-80V	4	
16	921900100001	Transducer DC48V 24V	1	
17	921900100004	Transducer DC24V 5V	4	
18	920200100002	Emergency switch CE4T-10R-01	1	
19	255033010001	Truck body harness (1234SE+AC)	1	
20	921000200067	Charger SN48V55A	1	400\450Ah Battery
	921000200068	Charger SN48V55A	1	400\450Ah Battery
	921000200069	Charger SN48V55A	1	400\450Ah Battery
	921000200070	Charger SN48V55A	1	6400\450Ah Battery
	921000200071	Charger SN48V55A	1	400\450Ah Battery

Electric system

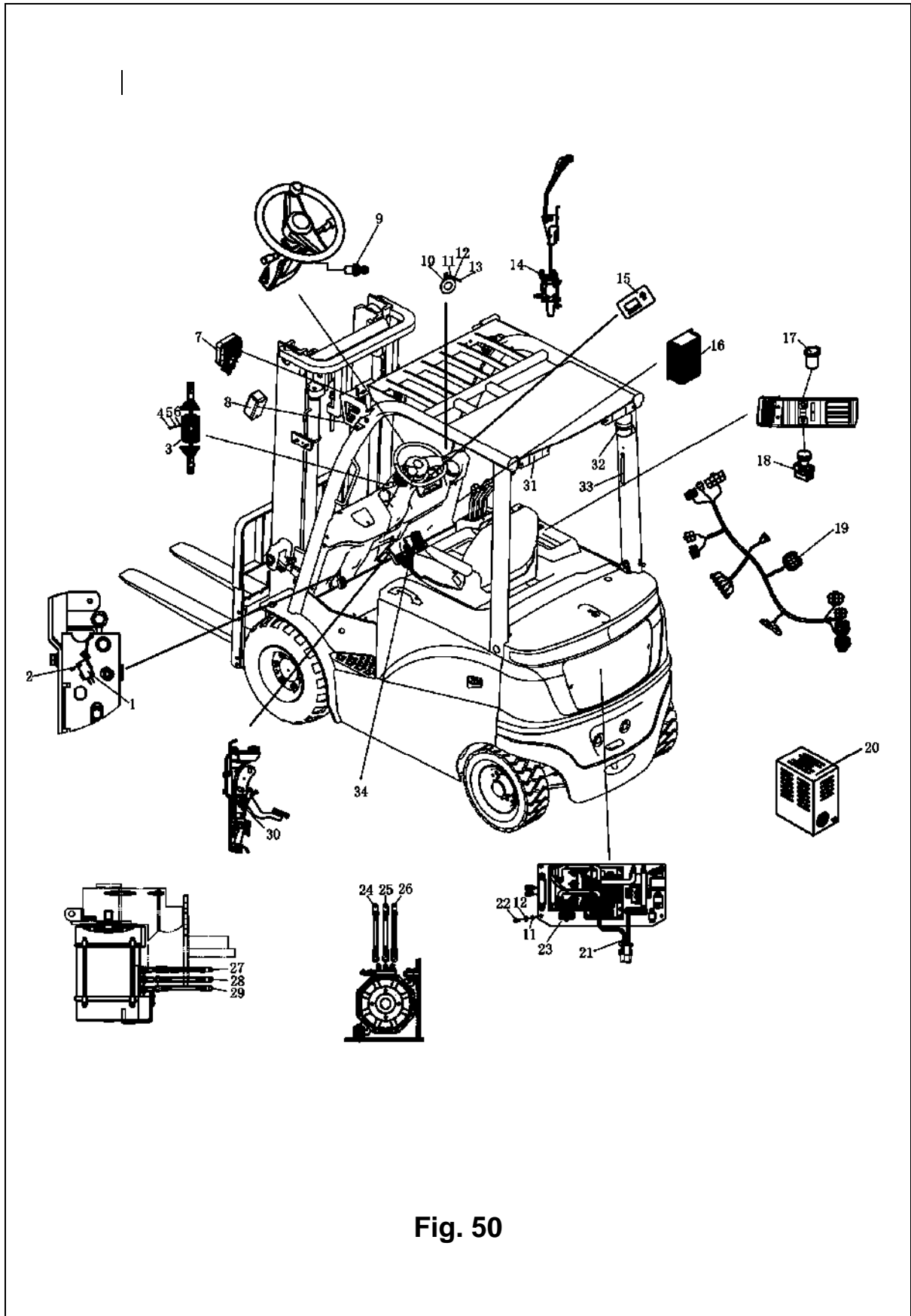

Fig. 50

Fig. 50**Electric system**

No.	Coding	Description	Qty.	Note
20	921000200072	Charger SN48V55A	1	400\450AhBattery
	921000200157	Charger SN48V65A	1	500AhBattery
	921000200158	Charger SN48V65A	1	500AhBattery
	921000200159	Charger SN48V65A	1	500AhBattery
	921000200160	Charger SN48V65A	1	500AhBattery
	921000200161	Charger SN48V65A	1	500AhBattery
	921000200162	Charger SN48V65A	2	500AhBattery
21	254133010004	Total Cable	1	
22	910200200058	ScrewGB70.1-M8x25-8.8	1	
23	254133010001	Electric control (1234E+AC)	1	
24	255033010005	Cable-U2-35-6-8-1350	1	
25	255033010006	Cable-V2-35-6-8-1300	1	
26	255033010007	Cable-W2-35-6-8-1250	1	
27	255033010002	Cable-U1-35-6-8-3100	1	
28	255033010003	Cable-V1-35-6-8-3050	1	
29	255033010004	Cable-W1-35-6-8-3000	1	
30	920201000002	Foot pedal JK231	1	
31	922000100003	Light PDL-LXHW-2	2	
32	922000100004	Light PDL-LXJD-01Y	1	
33	255033510001	Rear lever switch	1	Match
34	921700100005	Accelerator FZ3-532-133	1	

Electronic control element (CURTIS)

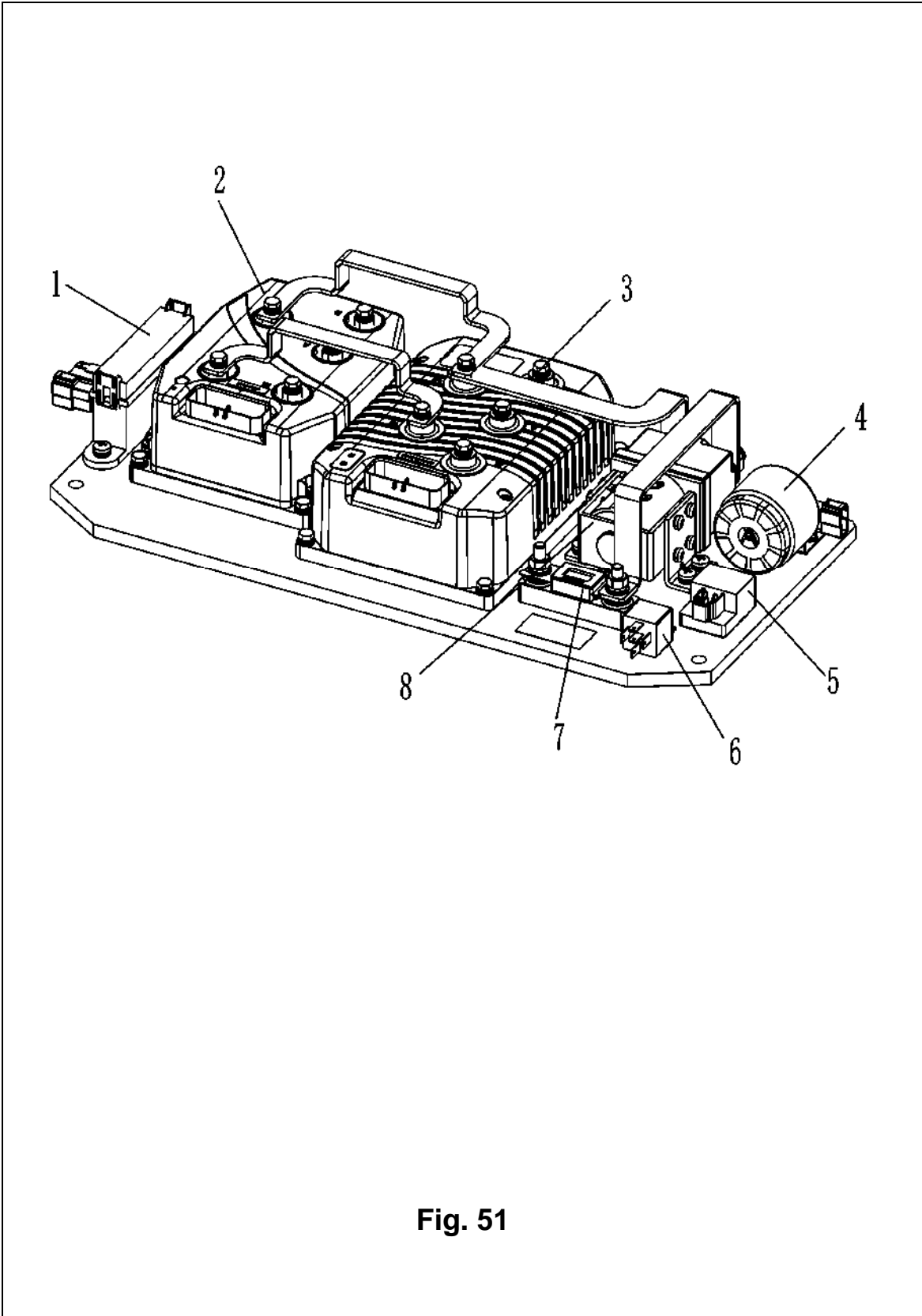

Fig. 51

Fig. 51 Electronic control element (CURTIS)

No.	Coding	Description	Qty.	Note
1	920100400008	Fuse box BX2081X	1	
2	921400100043	Controller 1232SE-5321	1	
3	921400100043	Controller 1232SE-5321	1	
4	920500100002	Buzzer DJB-24B	1	
5	922000100005	Light SG252-24V	1	
6	920800100002	Relay DC24V-HFV4	1	
7	920100100014	Fuse 500A	1	
8	920700100005	Contactor DC48C-SW200-262	1	

Power connector assembly

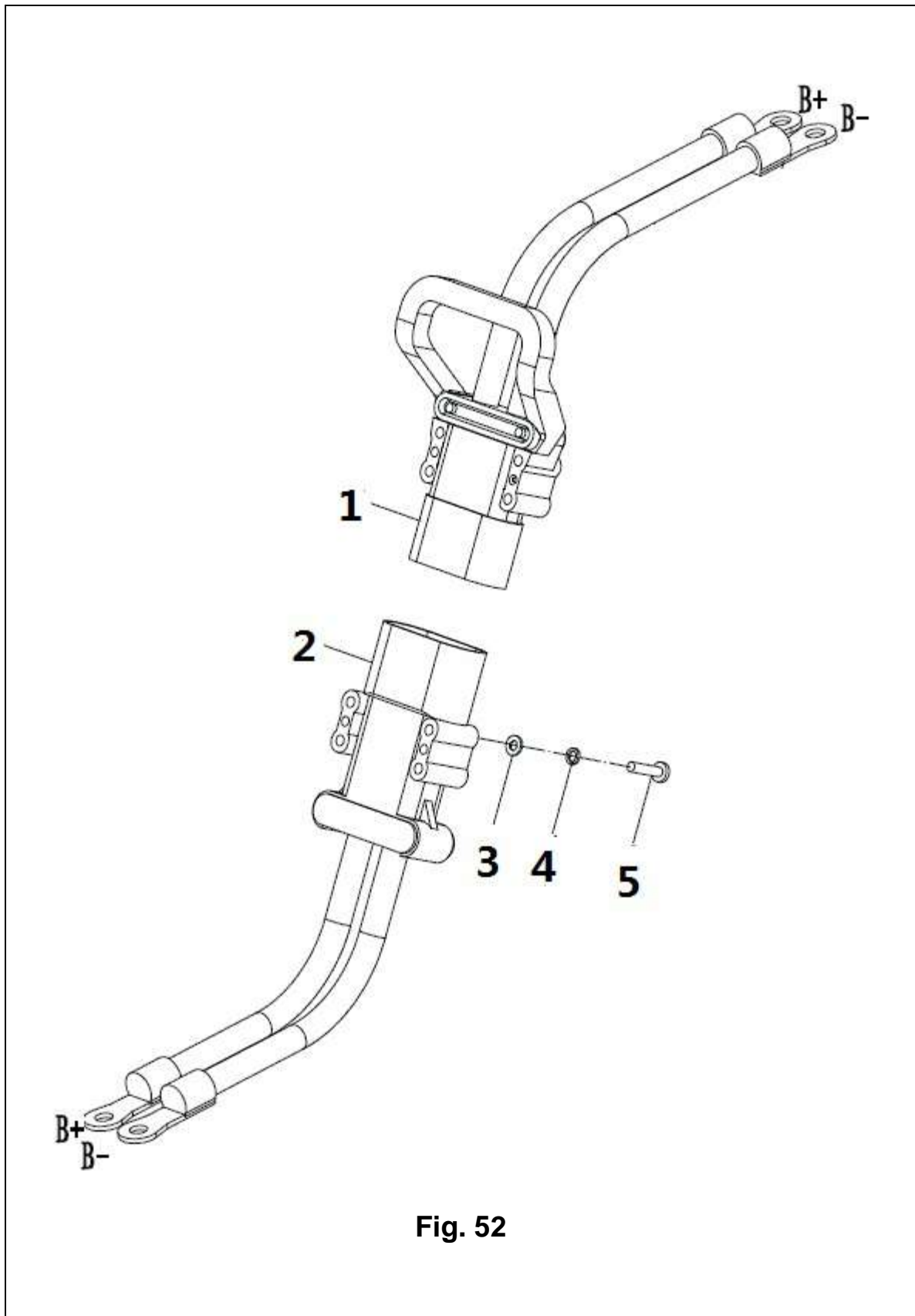

Fig. 52

Fig. 52 **Power connector assembly**

No.	Coding	Description	Qty.	Note
1	254137010022	Batteryconnecting cable (160A)	1	
	254137010028	Batteryconnecting cable (160A)	1	Elect install
2	254133010004	Battery cable	1	
3	910400100005	Washer GB97.1-6-200HV	4	
4	910400500005	Washer GB93-6	4	
5	910200200046	Screw GB70.1-M6x60-8.8	4	

Labels(Chinese)

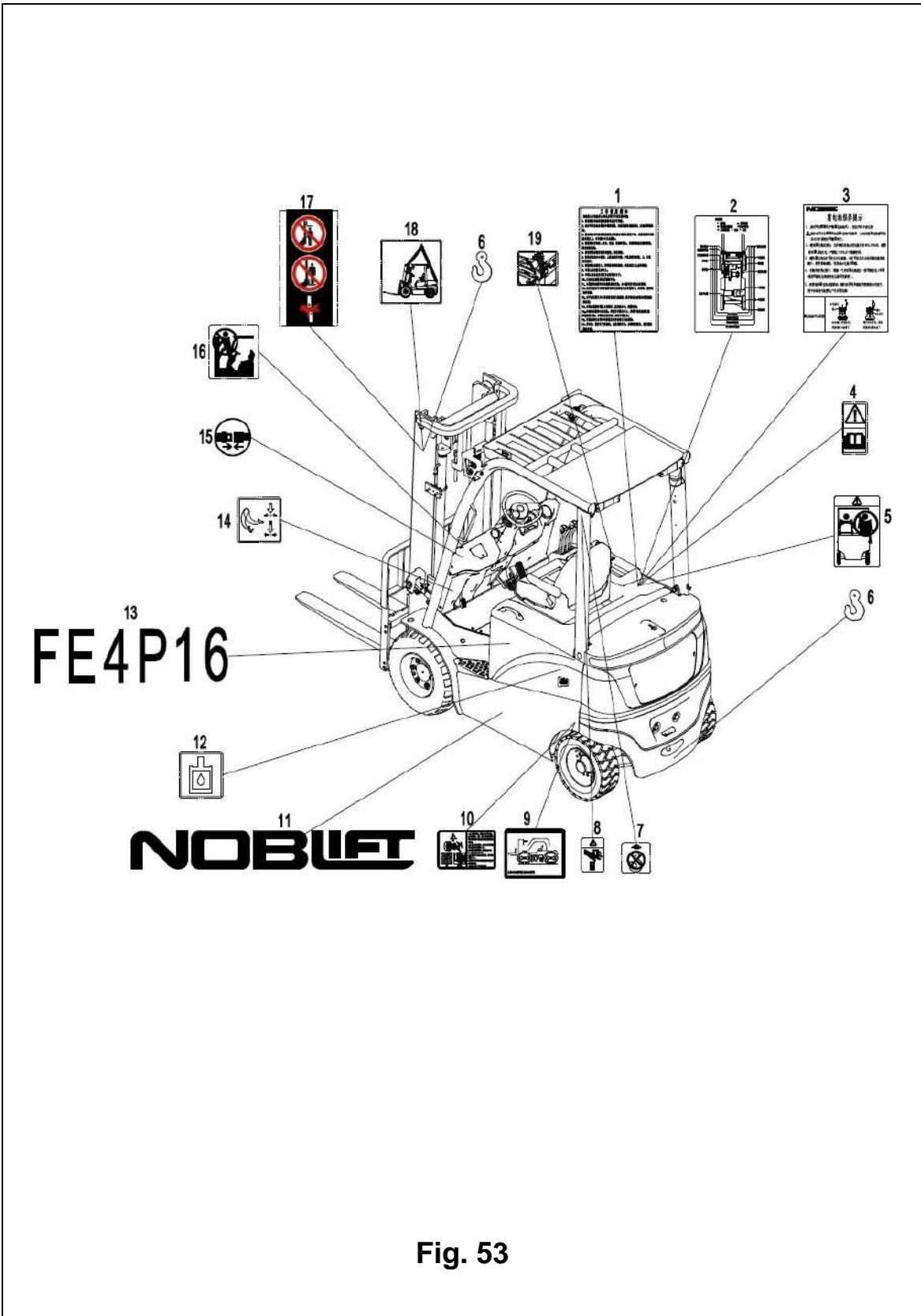

Fig. 53

Fig. 53**Labels(Chinese)**

No.	Coding	Description	Qty.	Note
1	251047020001	Sticker to read and follow this instruction	1	
2	253547020001	Lubrication points	1	
3	251047020015	Battery maintenance	1	
4	251047020004	Warning label	1	
5	251047020005	"No passengers" decal	1	
6	251047020006	Crane hook label	3	
7	251047020007	No crane label	2	
8	251047020008	Squeeze hand stick	2	
9	254147020002	Tyre pressure label	2	
10	253547020003	Tyre disassembly label	2	
11	253547020004	Noblelift logo	2	
12	255047020004	Hydraulic oil sticker	1	
13	254147020007	Product model sticker	2	1.6t
	254247020007	Product model sticker	2	1.8t
14	255047020001	Foot brake sticker	1	
15	251047020013	Safety belt sticker	1	
16	251047020014	No climbing	1	
17	253547020008	Safety label	2	
18	253547020009	Lifting label	2	
19	255047020006	Battery cover open sticker	1	

Labels(English)

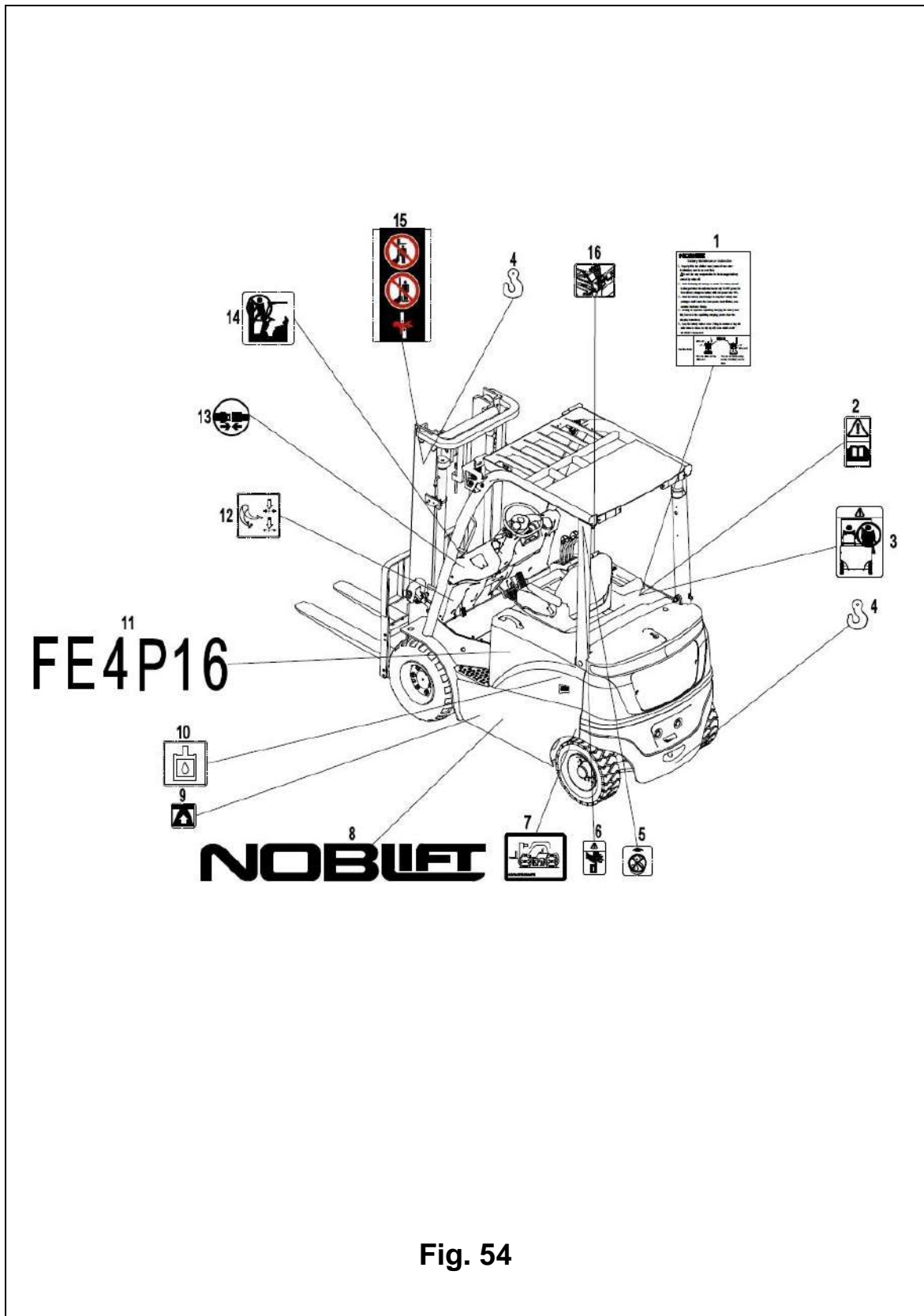

Fig. 54

Fig. 54**Labels(English)**

No.	Coding	Description	Qty.	Note
1	251047020015	Battery maintenance	1	
2	251047020004	Warning label	1	
3	251047020005	"No passengers" decal	1	
4	251047020006	Crane hook label	3	
5	251047020007	No crane label	2	
6	251047020008	Squeeze hand stick	2	
7	254147020002	Tyre pressure label	2	
8	253547020004	Noblelift logo	2	
9	251047020017	Supporting point label	1	
10	255047020004	Hydraulic oil sticker	1	
11	254147020007	Product model sticker	2	1.6t
	254247020007	Product model sticker	2	1.8t
12	255047020001	Foot brake sticker	1	
13	251047020013	Safety belt sticker	1	
14	251047020014	No climbing	1	
15	253547020008	Safety label	2	
16	255047020006	Battery cover open sticker	1	

Data nameplate (Chinese)

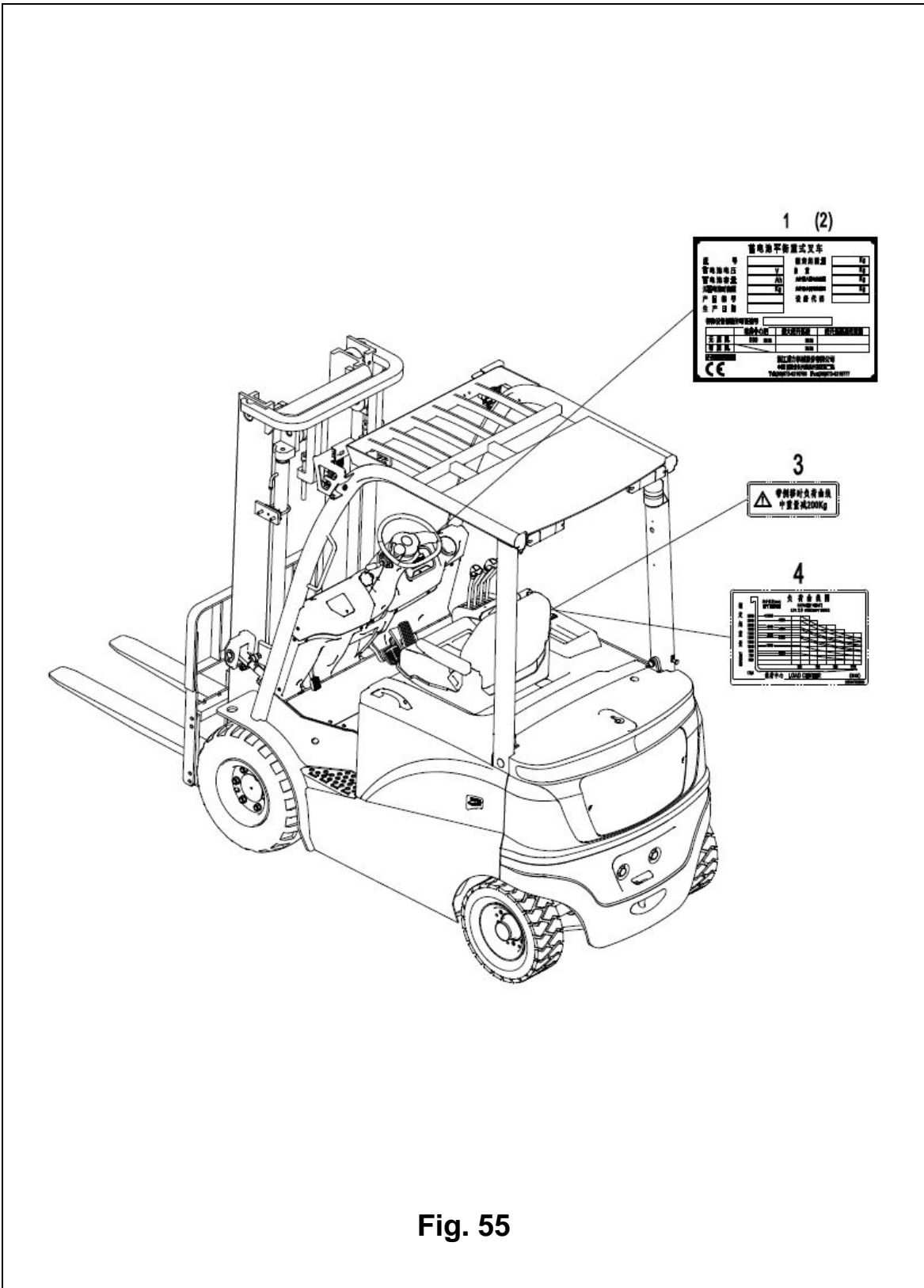

Fig. 55

Fig. 55 **Data nameplate (Chinese)**

No.	Coding	Description	Qty.	Note
1	254147520001	Nameplate	1	1.6t
	254247520001		1	1.8t
2	910500600002	Rivet GB827-3x10	4	
3	255047520004	Lose weight sticker with sidesway	1	
4	254147520003	Load capacity diagram	1	1.6t
	254247520003		1	1.8t

Data nameplate (English)

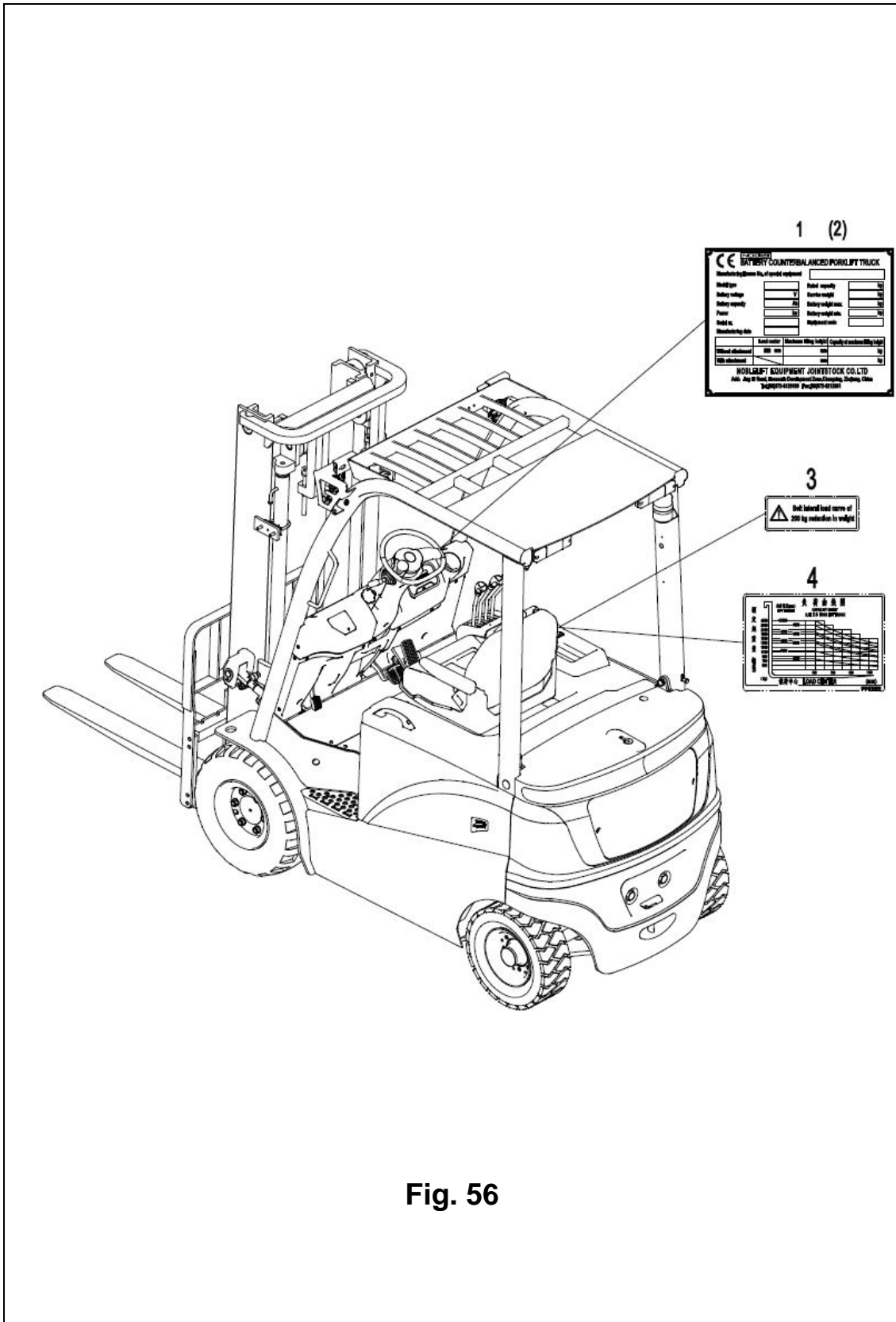

Fig. 56

Fig. 56 **Data nameplate (English)**

No.	Coding	Description	Qty.	Note
1	254147520002	Nameplate	1	1.6t
	254247520003		1	1.8t
2	910500600002	Rivet GB827-3x10	4	
3	255047520005	Lose weight sticker with sideway	1	
4	255047520003	Load capacity diagram	1	1.6t
	254247520003		1	1.8t

NOBLIFT

Noblelift Equipment Joint Stock Co. , Ltd

Service hotline: 4001-603611

Wechat: nuolijixie

Postcode: 313100 email address: info@noblift.com

Website: www.noblift.com

Address: 528 Changzhou Road ,Taihu Jiedao, Changxing, Zhejiang.



Version: November ,2016