



**SATOH  
TRACTOR  
*BULL*  
INSTRUCTION  
BOOK**



**SATOH AGRICULTURAL MACHINE MFG. CO., LTD.**



Any improper handling of the tractor could lead to an accident. Prior to the operation of the tractor, be sure to read this Instruction Manual carefully and have a thorough understanding of the description. In particular, the instructions given in "Safety Precautions" must be strictly followed.

## SAFETY PRECAUTION

- ☆ When running the tractor at high speed or on roads, make sure the right and left brake pedals are interlocked so that they will not be operated independently.
- ☆ Make sure that a guard is in place when operating the belt pulley or P.T.O. driven shaft.
- ☆ Always wear relatively tight and belted clothing when operating the tractor. Loose jackets, shirts sleeves or other loose clothing should not be worn because of the danger of catching them in moving parts, engine or implement.
- ☆ When leaving the tractor, be sure to stop the engine, apply the parking brake and pull out the starter key.
- ☆ Never make a sharp turn at high speed.
- ☆ When descending a slope in reverse, be sure not to abruptly operate the clutch or the brake.
- ☆ Never operate the differential lock when running on a public road.
- ☆ When making a sharp turn, confirm that the differential lock is disengaged.
- ☆ Never operate the tractor on a slope that seems to be dangerous. Do not operate the clutch, brake, throttle lever and steering wheel abruptly on a slope as it is dangerous. Be careful particularly when running on a slippery road.
- ☆ Do not carry any persons on the tractor, nor on the linkage drawbars and implement.
- ☆ When towing, set the hitch point below the center line of the rear axle.
- ☆ When refuelling, be sure to stop the engine. Also take special care so that fuel will not catch fire.
- ☆ Use a safe fuel container. Fill the tank outdoors and wipe up spilled fuel. Replace the fuel cap securely.
- ☆ Never touch engine parts after operating the tractor or the engine until parts have had sufficient time to cool.
- ☆ Always keep positive battery post covered with rubber boot on the end of the cable.
- ☆ Never operate the tractor engine in a closed building where carbon monoxide fumes can collect.
- ☆ Do not allow children to operate the tractor, nor adults to operate it without proper instructions.
- ☆ When mounting an implement on the tractor, be sure to follow the instructions given in "Safety Precautions" in the implement Operation Manual.

**SATOH**

***BULL***

With 2-cylinder KE-130 – 13B Diesel Engine.

## INSTRUCTION BOOK



**SATOH AGRICULTURAL MACHINE MFG. CO.,LTD.**

6-3 3-CHOME, KANDA, KAJI-CHO, CHIYODA-KU,  
TOKYO, JAPAN

PUBLICATION No. S-630US-5

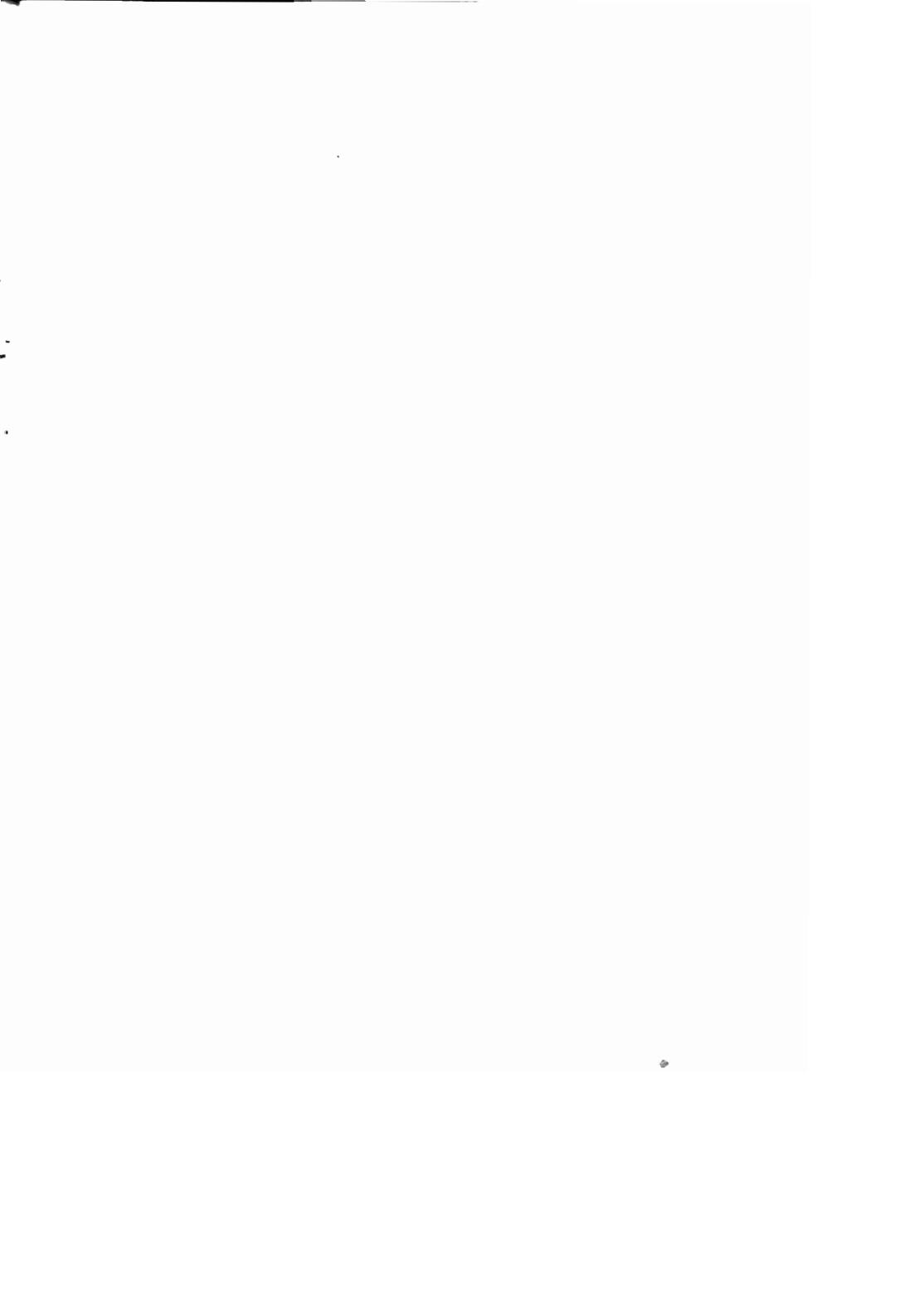

## INTRODUCTION

Equipped with a 2-cylinder, 25 HP diesel engine, the SATOH S-630 and S-630D tractors are, respectively, 2-wheel and 4-wheel drive type farm tractors with big capacity, high quality performance and outstanding durability providing increased economy.

Making the best use of long experiences and the latest technology of the SATOH engineers, the S-630 and S-630D are built sturdy and rugged in all their components which consist of unsurpassed and precision machined parts. The careful assembling work coupled with quite severe performance test and strict quality control makes assurance of high quality and top performance for the S-630 and S-630D.

This instruction manual contains information on the operation, lubrication and maintenance of your SATOH tractor. The information contained is comprehensive and essential, and is designed to assist you, if unexperienced, in utilizing your tractor.

How well your SATOH tractor continues to give satisfactory performance depends greatly upon the manner in which it is operated. It is, therefore, requested that this manual be read carefully and kept ready for use so that the operation and maintenance services will properly be carried out in order to keep the tractor in top mechanical condition at all times.

Should any information as to your tractor be required, consult your SATOH dealer or distributor stating the machine and engine serial numbers of the tractor concerned.

We are sure you will be happy with SATOH tractor.



Tractor Serial No.

563A-00760 NEW  
4-82

Engine Serial No.

23PS-16001

## CONTENTS

Safety Points	
Introduction	
Treatment of a New Tractor . . . . .	2
50-Hour Service . . . . .	2
External View and Nomenclature of Each Part . . . . .	3

### SECTION 1. OPERATION

Starting and Stopping the Engine . . . . .	6
Starting . . . . .	6
Starting in Cold Weather . . . . .	7
Important . . . . .	8
Stopping . . . . .	8
Instruments and Controls . . . . .	8
Tractor Meter . . . . .	8
Oil Pressure Warning Lamp . . . . .	9
Battery Charge Warning Lamp . . . . .	9
Water Temperature Meter . . . . .	9
Light Switch . . . . .	10
Safety Starter Switch . . . . .	10
Glow Plug . . . . .	11
Glow Signal Lamp . . . . .	11
Speed Control Lever . . . . .	12
Foot Throttle . . . . .	12
Clutch . . . . .	12
Brake . . . . .	13
Parking Brake . . . . .	14
12-Speed Transmission . . . . .	14
Differential Lock . . . . .	15
Engaging the Differential Lock . . . . .	15
Releasing the Differential Lock . . . . .	16
Power Take-Off . . . . .	16
4-wheel Drive Shift Lever . . . . .	17
Seat . . . . .	18
Tread Adjustments . . . . .	18
Front Wheel . . . . .	18
2-Wheel Drive . . . . .	18
4-Wheel Drive . . . . .	19
Rear Wheel . . . . .	20
Rear Wheel Installation . . . . .	20
Ballast Weight . . . . .	21
Tire Pressure . . . . .	22
3-Point Linkage . . . . .	23

Hydraulic System . . . . .	23
Control . . . . .	23
Position Control . . . . .	23
Flow Control & Lift Lock . . . . .	24
External Hydraulic Service . . . . .	25
Single Action . . . . .	25
Double Action . . . . .	26
Drawbar . . . . .	26

## SECTION 2. REGULAR MAINTENANCE

Service Schedule . . . . .	27
Service Schedule Chart . . . . .	28
Daily Inspection . . . . .	28
A-Service (Every 50 hours of operation) . . . . .	29
50 Hours Service for a New Tractor . . . . .	29
50 Hours Service for a Tractor That is Not New . . . . .	29
B-Service (Every 100 hours of operation) . . . . .	30
C-Service (Every 300 hours of operation) . . . . .	31
D-Service (Every 600 hours of operation) . . . . .	31
Maintenance Interval Chart . . . . .	32
Recommended Lubricants and Fuel . . . . .	33
Greasing Diagram . . . . .	34

## SECTION 3. SERVICE INFORMATION

Precautions to Be Taken in Cold Weather . . . . .	35
Antifreeze . . . . .	35
Fuel System Air Bleeding . . . . .	36
Fuel Filter Air Bleeding . . . . .	36
Fuel Pump Air Bleeding . . . . .	37
Fuel Pipe Air Bleeding . . . . .	37
Engine Oil Replacement . . . . .	37
Injection Nozzle Inspection . . . . .	38
Cylinder Head Bolt Tightening . . . . .	39
Valve Clearance Adjustment . . . . .	39
Timing Adjustment Procedure . . . . .	40
Cooling System . . . . .	40
Air Cleaner . . . . .	41
Engine Oil Filter Replacement . . . . .	41
Fuel Filter Element Replacement . . . . .	42
Transmission Case Oil Replacement . . . . .	42
Rear Axle Housing Oil Replacement . . . . .	44
Washing Hydraulic Oil Filter . . . . .	44

Replacement of 4-Wheel Drive Front Axle Oil . . . . .	45
Replacement of Front Axle Diff. Case Oil . . . . .	45
Replacement of Front Kingpin Gear Case Oil . . . . .	45
Replacement of Kingpin Gear Case Grease . . . . .	45
Clutch Pedal Adjustment . . . . .	46
Free Play Adjustment. . . . .	46
Brake Pedal Adjustment . . . . .	47
Free Play Adjustment. . . . .	47
Throttle Lever Adjustment . . . . .	48
Foot Throttle Adjustment. . . . .	49
Fan Belt Tension Adjustment . . . . .	50
Differential Lock Pedal Adjustment . . . . .	50
Hydraulic Control Adjustment. . . . .	51
Flow Control Lever Adjustment. . . . .	51
Hydraulic Pump Relief Valve. . . . .	52
Hydraulic Cylinder Relief Valve Adjustment. . . . .	52
External Hydraulic Service . . . . .	52
Front Axle Center Pin and Front Hub . . . . .	53
Battery . . . . .	53
AC Generator . . . . .	54
Starter Motor . . . . .	55
Regulator. . . . .	55
Glow Plug . . . . .	56
Fuse Box . . . . .	56
Safety Starter Switch Adjustment. . . . .	56
Circuit Diagram. . . . .	57

## SECTION 4. SPECIFICATIONS AND DATA

Engine. . . . .	58
Cooling System. . . . .	58
Fuel Equipment . . . . .	58
Lubrication System . . . . .	58
Air Cleaner. . . . .	58
Governor . . . . .	59
Electrical System. . . . .	59
Engine Performance Curves . . . . .	59
Glow Plug . . . . .	60
Dimensions of Standard Type . . . . .	60
Clutch. . . . .	60
Transmission . . . . .	60
Power Take Off. . . . .	60



Brakes. . . . .	.61
Steering. . . . .	.61
Tread Adjustment . . . . .	.61
Hydraulic Power Lift . . . . .	.61
3-Point Linkage. . . . .	.61
Wheel Equipment . . . . .	.61
Travel Speed. . . . .	.62
Capacities (Approximate initial fill) . . . . .	.62

## TREATMENT OF A NEW TRACTOR

All components of SATOH tractors model S-630 & S-630D are subject to stringent checking during assembly in the factory. However, a new tractor should be carefully checked over by the operator himself. For the first 25 ~ 50 hours operation, heavy duty work should be avoided. If heavy duty work is unavoidable, drive in a gear one stage lower than you would normally use, and run the engine at lower speed.

### 50-HOUR SERVICE

After the first 50 hours running, the following service, maintenance and checking should be carried out.

- (1) Replace the oil filter and engine oil.
- (2) Replace the transmission oil and clean the hydraulic oil filter.
- (3) Retighten all bolts and nuts.
- (4) Check and adjust the fan belt tension.
- (5) Check the wheels to see if their condition is good and tire pressure is correct.
- (6) Retighten the cylinder head bolts and adjust valve clearances.

This 50-hour Service is an essential procedure for keeping the tractor in top condition, so it must be done properly.

## EXTERNAL VIEW AND NOMENCLATURE OF EACH PART

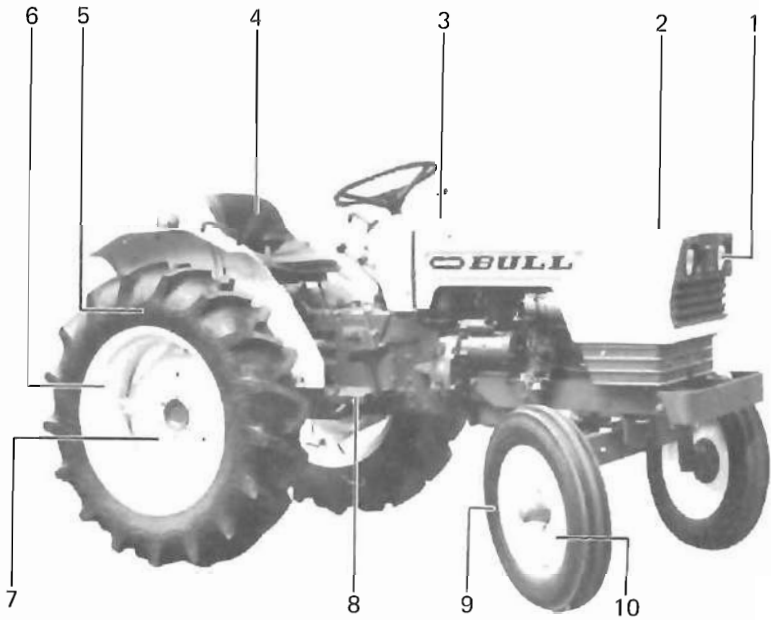

1. Headlight
2. Bonnet
3. Instrument panel
4. Seat
5. Rear tire

6. Rear wheel rim
7. Rear wheel disc
8. Step
9. Front tire 2-wheel
10. Front wheel

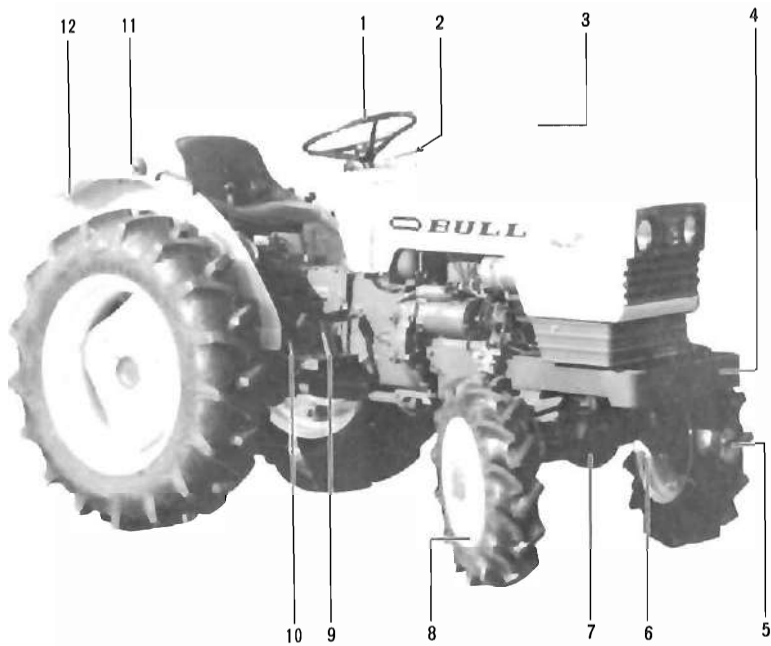

- |                       |                        |
|-----------------------|------------------------|
| 1. Steering wheel     | 7. Differential case   |
| 2. Throttle lever     | 8. Front wheel 4-wheel |
| 3. Muffler            | 9. Brake pedal         |
| 4. Bumper             | 10. Foot throttle      |
| 5. Front tire 4-wheel | 11. Flood lamp         |
| 6. King Pin gear case | 12. Fender             |

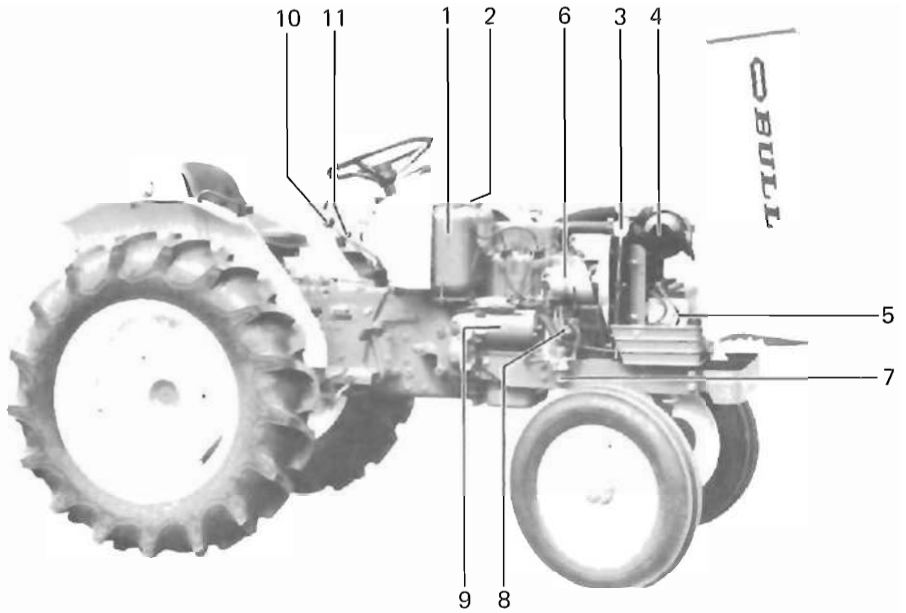

1. Fuel tank
2. Fuel tank cap
3. Radiator
4. Air cleaner
5. Battery
6. Alternator

7. Fuel strainer
8. Injection pump
9. Starter motor
10. Main shift lever
11. P.T.O. shift lever

# SECTION 1. OPERATION

## STARTING AND STOPPING THE ENGINE

Before starting the engine, be sure to check the following points.

1. Confirm that the fuel tank is filled with sufficient fuel.
2. Check the amount of oil in the engine, and transmission and check cooling water.
3. Always perform the daily maintenance described in of SECTION 2.

### STARTING

On the S-630 and S-630D, the safety starter switch is provided for preventing unforeseen accidents from breaking out in starting the engine. Installed between the starter switch and starter motor, the safety starter switch works as a kind of circuit breaker by which, in case that the clutch is not disengaged completely, the electric circuit in the engine starter motor can hardly be closed even when the starter key is turned to START.

1. Set the throttle lever at the center between idling and high speed.

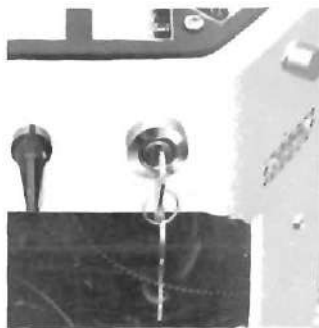

2. Place the main shift lever and P.T.O. shift lever in neutral. Then, fully depress the clutch pedal.
3. Insert the starter key into the key switch and turn it counterclockwise and hold it at "Heat" position to heat the glow plugs. As soon as the lamp on instrument panel glows red, about 30 seconds later rapidly turn the key to the "Start" position and the starter motor will rotate and the engine will start.

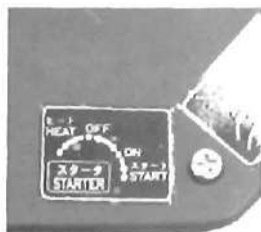

4. When the engine has started, take your hand off the key and the key then automatically returns to the "ON" position. The key must be in the "ON" position while the engine is running.  
Never rotate the engine at high revolutions. Run the engine at approximately 1,300 ~ 1,500 rpm and if the engine temperature rises, shift the throttle lever to SLOW (800 rpm).
5. After starting the engine, make sure the battery charge warning lamp and engine oil pressure warning lamp are off and the water temperature meter functions properly. If either or both lamps are on or the meter reads abnormal temperature, stop the engine immediately, isolate the cause and then take necessary countermeasures.
6. If the engine does not start on the first attempt, do not rotate the starter motor continuously more than 10 sec. Then, heat the glow plug well and restart the engine.
7. Warm up the engine especially in cold weather, before working.

#### STARTING IN COLD WEATHER

1. Shift the throttle lever to the position of the maximum revolution, and then the injection pump smoke set starts operating and fuel injection is increased.  
When the engine starts the smoke set is automatically released.
2. To start the engine in cold weather, heat the glow plug long enough to raise the temperature sufficiently in the combustion chamber.
3. When starting the engine, disengage the clutch by depressing the clutch pedal fully.

## NOTES:

- 1) After the engine has started, confirm that the engine is running smoothly listening carefully to ascertain if nothing abnormal sounds, and inspect for oil and water leakage.
- 2) In case fuel runs out, be sure to bleed the fuel system after re-filling the fuel tank; otherwise the engine may not be started (or even stopped soon after started). (See SECTION 3. BLEEDING THE FUEL SYSTEM)



### IMPORTANT:

Never use ether to start the engine of model S-630 & S-630D tractors.

## STOPPING

After idling the engine for a while by setting the throttle lever at the appropriate position, bring the throttle lever fully to the "STOP" position, and fuel is then cut off and the engine will stop.

Be sure to turn the starter key "OFF" when the engine has been stopped. When the operator leaves the tractor, take out the key.



## INSTRUMENTS AND CONTROLS

### TRACTOR METER

The tractor meter shows the engine speed, tractor travelling speed (km/h and mil/h) and running hours (accumulated hours). The engine speed reads on the lower side of the meter and the tractor travelling speed on the upper side of the same. The tractor travelling speed is shown in km/h and mil/h at the 9th speed. The hours meter read on the lower center shows the accumulated running hours at the rated engine speed.

In addition the tractor meter includes oil pressure warning lamp and battery charge warning lamp.





### OIL PRESSURE WARNING LAMP

When the starter key is switched "ON", this lamp glows red. When oil is circulating normally while the engine is running, the lamp turns off. If the lamp still glows red after the engine has been started, stop the engine immediately and check the engine lubrication oil level. If that is OK, check the oil pressure switch and cabling. If there are any defective switches or cables, replace them.

### BATTERY CHARGE WARNING LAMP

When the starter switch is set to "ON", this lamp glows green. When the battery is being charged normally while the engine is running the lamp turns off. If the lamp continues to glow, stop the engine immediately and check the alternator, regulator and cabling. If anything defective is found, replace it.

### WATER TEMPERATURE METER

The water temperature meter shows the temperature of the engine cooling water in centigrade degrees ( $^{\circ}\text{C}$ ). If the meter reads over  $105^{\circ}\text{C}$  ( $221^{\circ}\text{F}$ ), this means the engine is overheated: in such a case, stop the engine and check the cooling water level, fan belt tension and inspect for damage, and the radiator clog, and then take the necessary countermeasures.



**NOTE:** \_\_\_\_\_  
Utmost care should be taken when removing the radiator cap with the engine overheated.  
\_\_\_\_\_

## LIGHT SWITCH

The head light switch is located next to the starter switch on the operator side of the instrument panel.



OFF . . . . .Lights are off.

☾☽ . . . . .Headlight is dimmed and directed downwards.

☽☾ . . . . .Headlight is on.

**NOTE:** \_\_\_\_\_  
The switch for the working lamp is incorporated in the light itself.  
\_\_\_\_\_

## SAFETY STARTER SWITCH

As mentioned previously in this book, the safety starter switch is provided on SATOH S-630 and S-630D tractors for preventing uniforessen accidents at the start of the engine. Assembled in the engine starting system between the starter switch and the starter motor, the safety starter switch works as a circuit breaker in relation to the clutch pedal operations; unless the clutch pedal is fully depressed to completely interrupt the power from the engine to the transmission, the safety starter switch remains off, keeping the starter motor circuit to open even when the starter key is turned to START.

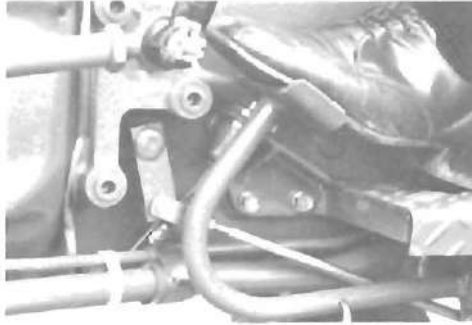

### GLOW PLUG

The engine of the SATOH tractors model S-630 & S-630D is fitted with sheathed type glow plugs which preheat the combustion chamber so that the engine may be started easily even in cold weather.

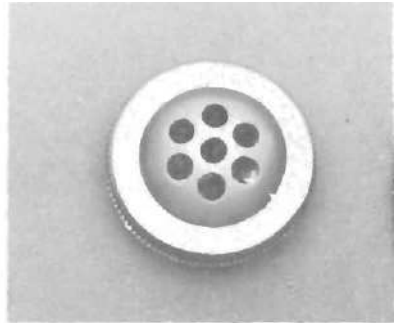
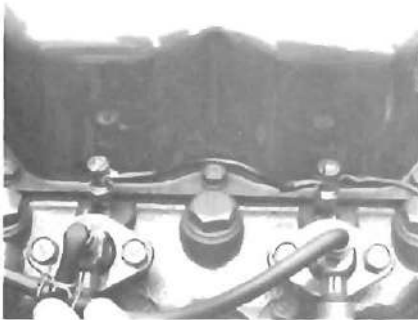

### GLOW SIGNAL LAMP

The glow signal lamp which indicates the heating state of the glow plug in the combustion chamber is installed on the instrument panel. It is easily seen from the heating condition of the glow signal lamp resistance wire.

## THROTTLER LEVER

When the speed control lever is pulled fully toward the operator, the engine speed reaches the maximum of 2,750 rpm.

The rated speed of the Engine Model KE-130-13B is 2,500 rpm. This engine speed is not only the most appropriate one to get the longest service life from your tractor but also the most economical one. It is the best therefore, to run the engine at the rate of 2,500 rpm.

## FOOT THROTTLE

The foot throttle pedal is installed on the right side of the step. When the hand throttle lever is in the idling position, the engine can be controlled to be at any speed within the range by depressing the pedal.

### NOTE:

When the hand throttle lever is in a high rev. position, the foot throttle also moves into the position for those revs. When this is done the revolutions cannot be controlled by means of the foot pedal within the range below the revs. set by hand lever.

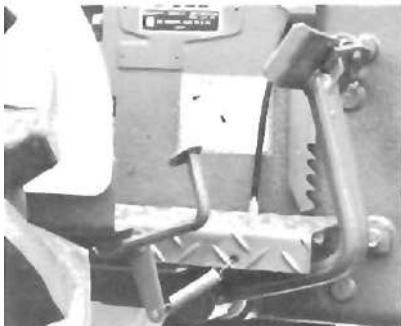

## CLUTCH

Depress the clutch pedal fully to bring the machine to a complete halt when shifting the gear in the transmission for changing the machine propelling speed. For shifting the P.T.O. gears, follow the similar manner.

Lowering the speed, when the tractor is overloaded, by half engaging the clutch or changing gear at high speed will damage the clutch lining.

De-clutching must be performed completely in one clean quick movement with the engine revs. lowered as much as possible.



## BRAKE

The brake on SATOH tractors model S-630 & S-630D is of internal expansion type and is dirt and water proof.

There are two pedals provided on the right side of the transmission case which are interlocked by a locking plate. The brake is applied by depressing these pedals. To stop the tractor, lower the engine revolutions, depress the clutch pedal and then the brake pedal. To shorten the braking distance, lower the engine revolutions quickly, depress the brake pedal and then the clutch pedal just before the engine stops.

For turning in a confined space the right and left axles can be braked independently by removing the locking plate interlocking the right and left brake pedals. When travelling at high speed or on roads make sure that the right and left brake pedals are interlocked by means of the locking plate.

When starting to travel on roads after one of the brakes has been operated more often than the other, check the balance of the right and left brakes beforehand. It is also necessary to check brake balance once a week. If you fail to check the brake balance or to interlock the right and left brake pedals, there is the most likelihood that an accident will occur.



## PARKING BRAKE

When parking, apply the parking brake by locking the main brake pedals in the following manner:

Interlock the right and left brake pedals by the locking plate. Keeping the pedals depressed, lock the pedals by the parking brake lever.

For releasing lock of the parking brake, depress the brake pedal further stronger, and push the parking lever forwards.



## 12-SPEED TRANSMISSION

The transmission on the S-630 and S-630D is of selective sliding mesh gear type, providing a total of 12 speeds – 9-forwards and 3-reverse – by the combination of the main shift lever and the sub shift lever, which are located on the upper right of the transmission case and on the left side of the operator's seat respectively.



**NOTE:**

When you change the gear shift, lower the engine speed and depress the clutch pedal to disengage the transmission clutch. After stopping the tractor, shift the gears.

## DIFFERENTIAL LOCK

This device links the right and left wheels in the transmission and rotates them at the same speed to prevent either wheel from slipping and to increase traction force.

### ENGAGING THE DIFFERENTIAL LOCK

Before the tractor slips and the speed is lowered, depress the pedal with your right foot and engage the differential lock. If the differential lock does not engage at the first attempt, repeat the operation more forcibly. If it still does not engage, lower the engine speed and after disengaging the running clutch, repeat the whole operation described above.



## RELEASING THE DIFFERENTIAL LOCK

The differential lock is automatically released by the force of the spring when you put your right foot off the pedal. However, under particular conditions, there may be occasions when the lock does not release.

When this occurs, depress the right and left brake pedals alternately and quickly until the lock is released. If this happens during plowing, depress the pedal on the unplowed side and the lock will be released.

When the right and left brakes are interlocked, the lock is released by turning the steering wheel sharply to the left and the right. When the differential lock is not released by any of these means, reverse the tractor a short distance.

**NOTE:** \_\_\_\_\_

Refrain from using the differential lock when running at high speed or on a road.

---

## POWER TAKE OFF

By operating the P.T.O. shift lever located on the upper left of the transmission case, the four P.T.O. speeds — 555 rpm, 774 rpm, 1,025 rpm, 1,320 rpm — can be selected.

When shifting the P.T.O. shift lever, depress the clutch pedal fully to interrupt the power from the engine and make sure the machine is brought to a complete halt.



First . . . . . 555 rpm/2,500 engine rpm  
Second . . . . . 774 rpm/2,500 engine rpm  
Third . . . . . 1,025 rpm/2,500 engine rpm  
Fourth . . . . . 1,320 rpm/2,500 engine rpm

Standard P.T.O. speed:

540 rpm/2,432 engine rpm (first)  
1,000 rpm/2,439 engine rpm (third)



## NOTES:

- 1) When any implement is towed by the tractor, care should be taken so that the universal joint does not form an angle more than  $15^{\circ}$ .
- 2) When the tractor is working with an impact load, correctly adjust the slide clutch on the implement side so that the P.T.O. is not overloaded.
- 3) To reduce the thrust load to the P.T.O. driven shaft as much as possible, it is advisable to test operation with an implement without any load.
- 4) Lubricate the P.T.O. driven shaft well.
- 5) Avoid using a square-shaped drive shaft as much as possible.
- 6) Special care should be given to the yoke position so that the driven shaft is well balanced.

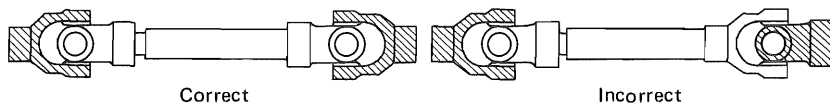

## 4-WHEEL DRIVE SHIFT LEVER

The 4-wheel drive shift lever is located on the left of the transmission case and it should be operated in the similar manner to that for the machine and P.T.O. speed shift levers.



## OPERATOR'S SEAT

A deluxe foam rubber operator's seat is provided on the S-630 and S-630D . It is adjustable in 3 stages at intervals of 1.10" (28mm) to suit it to the operator's stature.



## TREAD ADJUSTMENT

### FRONT WHEEL 2-WHEEL DRIVE

Front tread is adjustable in five stages between 42.1 in. (1,070m/m) and 57.9 in. (1,470m/m) to meet the requirement of each usage purpose. Make adjustment as follows according to the type of works to be required.

1. Apply jack under the center beam and jack up the front.
2. Loosen the tie-rod clamp bolt and take out the pin.

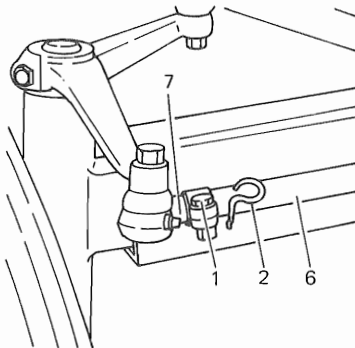

1. Clamp bolt
2. Snap pin
3. Front axle tightening
4. Center beam

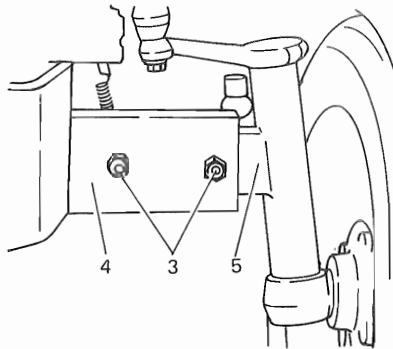

5. Axle outer
6. Tie rod
7. Tie rod inner

3. Loosen the front axle setting bolt, adjust the axle outer tread properly for its usage purpose.  
Tightening torque: 72.2 – 86.7 ft-lb (10 – 12 kg-m)
4. After obtaining the required tread make proper adjustment of toe-in and then tighten the clamp bolt.

Toe-in 0.16 – 1.31 (4 – 8m/m)

Clamp bolt tightening torque: 12.3 – 14.4 ft-lb (1.7 – 2.0 kg-m)

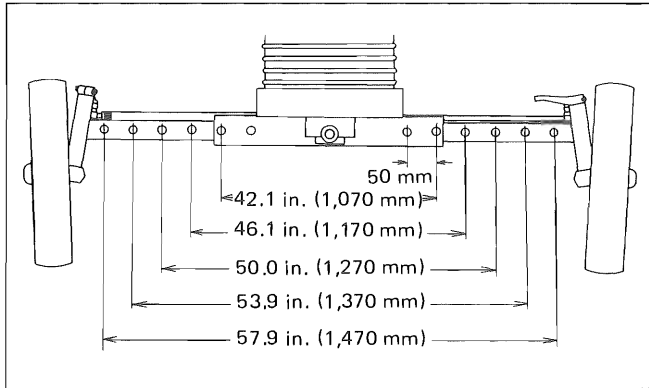

#### 4-WHEEL DRIVE

The tread of the 4-wheel drive tractor is 35.8 in. (910mm).

Front tread : 35.8 in. (910mm)

Front wheel tightening torque : 86.8 – 97.6 ft-lb (12.0 – 13.5 kg-m)

Axle center-and-kingpin case tightening torque : 28.9 – 36.2 ft-lb  
(4 – 5 kg-m)

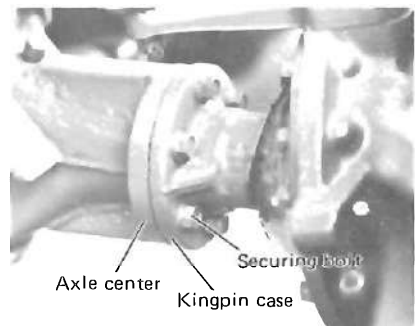
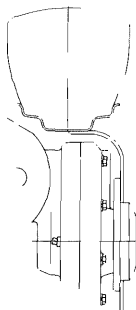



## IMPORTANT

1. Avoid widening front tread of the 4-wheel drive tractor by switching the right and left front tires as this may cause serious troubles on the steering linkage.
2. Check at frequent intervals to make sure that the front wheel is tightened securely to specified torque and that the axle center and kingpin case are secured each other to specified torque.

## REAR WHEEL

### 2-wheel and 4-wheel

Rear wheel tread is adjustable in six stages between 38.0 in. (965 m/m) and 50.4 in. (1,280 m/m) by combination shown below.

Jack up the rear of the tractor and make adjustment of tread as required with reference to the following figure.

Tightening torque:      Hub bolt 72.2 – 86.7 ft-lb (10 – 12 kg-m)  
                                 Rim & Disc 112 – 126 ft-lb (15.5 – 17 kg-m)

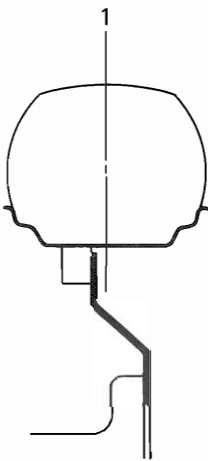

38 in. (965 mm)

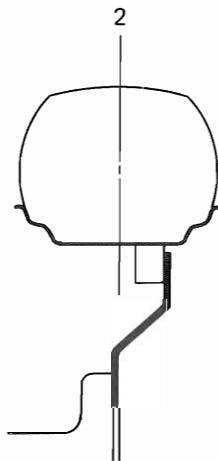

39.5 in. (1,005 mm)

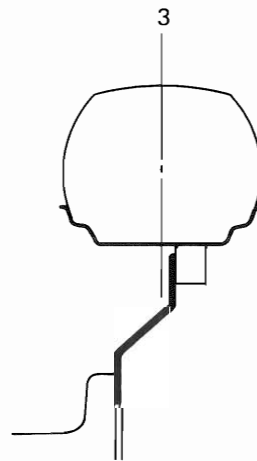

44.1 in. (1,120 mm)

### NOTE:

1. Tighten each bolt securely according to the specified tightening torque with special attention to tightening rims and wheel disc.
2. Tread adjustment requires enough space and careful job.

## REAR WHEEL INSTALLATION

Make sure that the rear tires are mounted so that the lugs on the tire form the staggered V's in series as viewed from the front of the tractor.



## BALLAST WEIGHT

The slipping not only damages the tire but also results in working inefficiency and greater fuel consumption. Slipping, therefore, must be minimized as much as possible. For that purpose, ballast weights are available as optional equipment. It is recommended that the tractor be provided with ballast weights when working in the place where slipping is likely to occur. The ballast weights can be attached on front and rear wheel discs and the front of the chassis. Ballast can also be applied by putting water into the tires instead of using the ballast weights. For this operation, pay particular attention to the temperature and air pressure. In cold weather where the temperature drops below 32°F (0°C), use water with antifreeze and never fill the tire with only water. It is of course

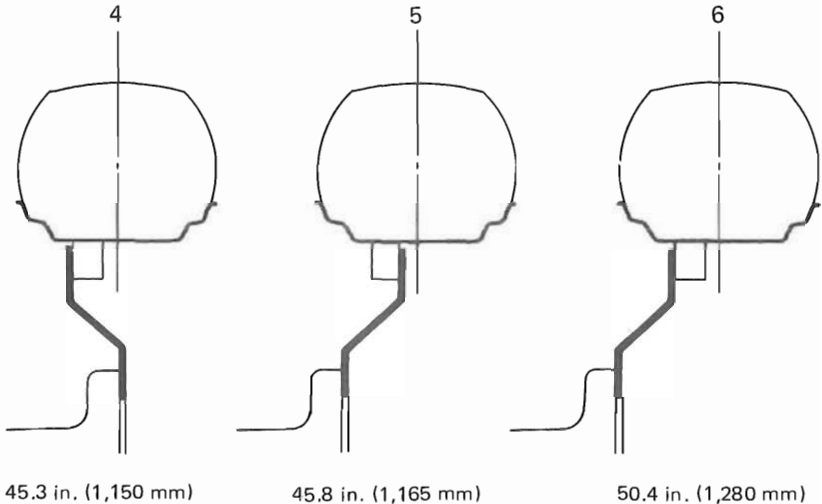

possible for you to employ a combination of water in the tires and ballast weights. Consult your dealer concerning the water injector and method of injection.

Front wheel weight:

Inside 27.5 lb(12.5 kg) x 4 = 110 lb(50 kg)

Rear wheel weight: 55 lb(25 kg) x 4 = 220 lb(100 kg)

Chassis weight: 44 lb(20 kg) x 4 = 176.2 lb(80 kg)

## TIRE PRESSURE

Tire pressure should be checked frequently. Either too high or too low pressure results in deterioration of the tire. To properly maintain the tires, make sure that the tire pressure is checked at least once a week.

		Tire size	Ply	Pressure	Valve type	Remarks
AG	Front	2WD 500-15	4	36.93 psi (2.6 kg/cm <sup>2</sup> )	TR-15	Inflation pressure shown is the max.
		4WD 6-14	4	28.44 psi (2.0 kg/cm <sup>2</sup> )	TR-13	
	Rear	11.2-24	4	16.00 psi (1.13kg/cm <sup>2</sup> )	TR-218A	Inflation pressure shown is the max.
ES	Front	2WD 5.90-15	4	28.44 psi (2.0 kg/cm <sup>2</sup> )	TR-15	
		4WD 6-14	4	28.44 psi (2.0 kg/cm <sup>2</sup> )	TR-13	
	Rear	11.2/10-24	4	17.0 psi (1.2 kg/cm <sup>2</sup> )	TR-15	
WTT	Front	2WD 20x800-10	4	12.0 psi (0.84kg/cm <sup>2</sup> )	TR-413	
		4WD 6-14	4	28.44 psi (2.0 kg/cm <sup>2</sup> )	TR-13	
	Rear	13.6-16	4	22.0 psi (1.55kg/cm <sup>2</sup> )	TR-218A	

### NOTE:

Air pressure of the tires must be changed according to the loading weight on the tires. For more details, please call and talk with your local Satoh Dealer.

## THREE-POINT LINKAGE

The 3-point linkage of S-630 and S-630D belongs to the Category 1, which is designed for a wide range of implements.

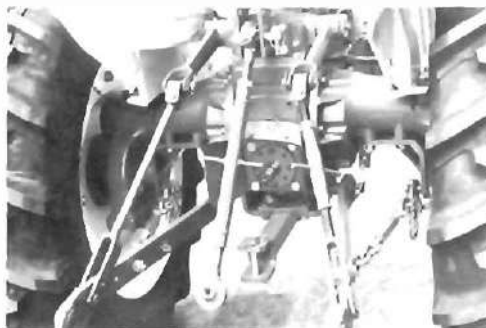

## HYDRAULIC SYSTEM

Employed in S-630 and S-630D is SATOH 'live' hydraulic system that makes the hydraulic energy available whenever needed while the engine is running, the hydraulic pump being directly mounted on the timing gear case of the engine.

The oil used is SAE #80 gear oil, the same as that for the transmission system, and is filtered through a 100-mesh oil filter.

Control levers located on the right of the operator's seat are for lift control, position control, flow control (lowering speed control) and lift lock of the implement.

The TP 1/4 tap hole is furnished, ensuring easy external maintenance services of the system.

## CONTROL

### POSITION CONTROL

To control the implement in lifting and lowering, operate the hydraulic control lever.

Moving the control lever more or less along the quadrant actuates the spool valve in the control valve, through which the oil from the pump flows into the cylinder, causing the implement to be lifted or lowered.

If, in some duty operations, the implement is required to limit its lift

to be below the maximum stroke, set the stopper on the quadrant to the desired position, at which the control lever stops, causing the implement to lift not more than the limited position at all times.

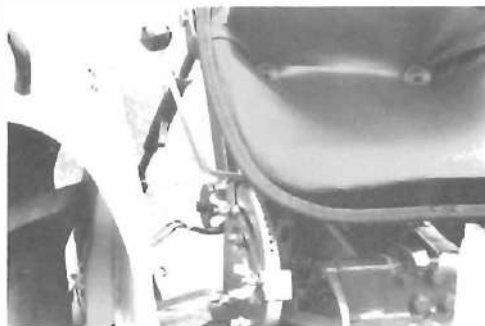

#### FLOW CONTROL & LIFT LOCK

To control the lowering speed of the implement, operate the flow control lever furnished to the hydraulic lift case located on the lower right of the operator's seat.

To increase the lowering speed, turn the lever counterclockwise. To reduce the speed, turn the lever clockwise; to lock the lever, turn it further.

Set the lever to the desired speed position according to the type of operations.





## EXTERNAL MAINTÉNANCE SERVICES

The SATOH S-630 and S-630D are equipped with the hydraulic power take off tap for transmitting the power from the tractor to the implement.

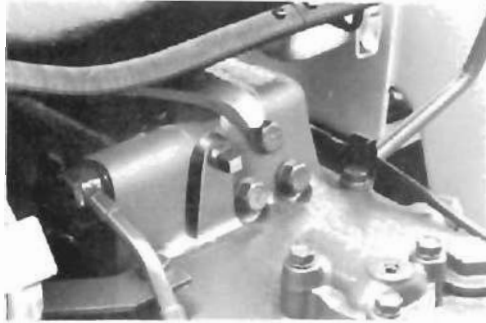

If the implement of single action cylinder type is mounted, use the control valve provided on the tractor.

When the implement of double action type is used, install a double action control valve which is available as an optional part.

## SINGLE ACTION

Start the engine and lift the implement. Then, turn the flow control valve clockwise until the implement is locked.

Fit the control lever to the cut on the upper portion of the quadrant and set the stopper right behind the control lever. Moving the control lever forward over the stopper allows the implement to lift; pull backward for lowering.

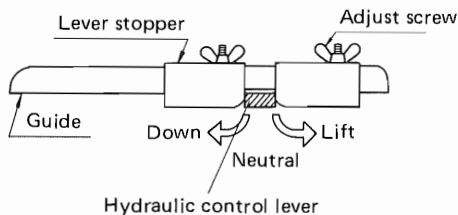

**NOTE:** \_\_\_\_\_

When the implement is firmly lifted up to the desired position, be sure to return the control lever to the cut (neutral position) so that the pump is in no-load condition.

\_\_\_\_\_

## DOUBLE ACTION

Push the control lever forward over the cut in the quadrant. Set the lever by the stopper provided in front of the lever so that the oil keeps flowing into the double action control valve optionally installed.

The oil hose should also be installed beforehand, through which the oil from the double action system returns to the transmission case oil inlet.

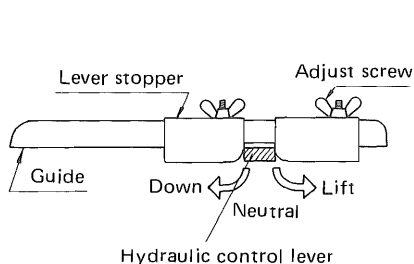

**NOTE:**

In the case of hydraulic external take off check the oil level of the transmission before starting works with an implement mounted and if not enough supply oil up to the specified level.

The required transmission oil for supplying is 1.057 gal.(4 ㉔).

## DRAWBAR

The SATOH S-630 and S-630D are equipped with a rigid type drawbar.



## SECTION 2. REGULAR MAINTENANCE

To keep your tractor operating in the top condition and to assure its proper performance and reliability for a long period of time, periodic inspection is indispensable. If your tractor is not periodically serviced, the result will be such that its performance and operating life will be reduced. Also a major breakdown is more likely to occur, which will entail much more expense than that which you would pay for regular maintenance.

Maintenance and servicing of SATOH S-630 & S-630D are very important items, however, the procedure is very simple. Carry out daily checking, greasing and periodic service by carefully following the instructions given in this manual. In addition to **daily inspection** the following servicing must be carried out.

50-hour service to be carried out on a new tractor

A-service.....Service every 50 hours

B-service.....Service every 100 hours

C-service.....Service every 300 hours

D-service.....Service every 600 hours

**NOTE:** \_\_\_\_\_

The tractor should always be kept clean. Before greasing or removing the oil pan plug and filler cap, be sure to wipe the surface clean. When using tools for repairing inside the engine, transmission, fuel tank or hydraulic unit, clean the tools before use. Be careful especially when refueling. If dust or water gets in the fuel, engine trouble will be experienced, resulting in loss of power and the unexpected necessity of parts replacement. The tractor should be serviced indoors where is plenty of room and it is as clean as possible.

---

### SERVICE SCHEDULE

Observe the following service schedule. This service schedule is applied to tractors which are operated under normal conditions. When your tractor is frequently operated in muddy places, greasing must be carried out more frequently and when the tractor is often operated in dusty places, clean the air filter element or fuel filter more frequently. Extra servicing must be carried out according to the situation.

## SERVICE SCHEDULE CHART

Hours of operation	A service	B service	C service	D service
50	○	○		
100	○	○		
150	○			
200	○	○		
250	○			
300	○	○	○	
350	○			
400	○	○		
450	○			
500	○	○		
550	○			
600	○	○	○	○

- \* After completing the first 600 hours operation, repeat the items according to the service schedule given in the above chart.
- \* Usually B service is carried out every 100 hours. For a new tractor, however, B service should be carried out at the 50 hours service.

## DAILY INSPECTION

1. Check for leakage of oil, water or fuel and if any repair the part.
2. Check the engine oil, transmission oil and cooling water. If the quantity is not proper, remedy the shortage.
3. After finishing work, replenish fuel within 1 inch (25 mm) below the fuel tank filler cap.
4. After working in a dusty place, clean the air cleaner element and after working in a place with dry grass, clean the radiator screen.
5. Tightening nuts and bolts  
Make further tightening of the setting bolts of front wheel, rear wheel, rim and wheel disc and then of other bolts and nuts.
6. After working in a muddy place, grease the king pins, front hubs, front axle center pin and brake shaft via the grease nipples provided.
7. Check the tire pressure and adjust if necessary.

8. Check the brake and clutch pedals for free play.  
If it is not as specified, make necessary adjustments.
9. All moving portions must be cleaned and lubricated with engine oil so that they work smoothly. Lubrication has the reverse effect in an extremely dry or dusty place. Therefore avoid lubrication if working in such a place.
10. Check the electrolyte level in the battery, if it is below the specified level add distilled water.
11. Check the fan belt tension and if it is slack adjust it.
12. Check the oil level in the front axle differential case and the front gear case of the 4-wheel drive tractor.

## A-SERVICE (Every 50 hours of operation)

### NOTES:

---

- 1) A new tractor needs careful attention. The following should be read carefully to understand all the things to be done.
  - 2) Some items described here are the same as for daily inspection but special care should be given to them when carrying out the 50 hours service.
- 

## 50 HOURS SERVICE FOR A NEW TRACTOR

1. Replace the engine oil.
2. Replace the engine oil filter.
3. Clean the engine fuel filter.
4. Clean the air cleaner element.
5. Replace the transmission oil.
6. Check the oil of rear axle housing case.
7. Clean the hydraulic oil filter.
8. Tighten the engine cylinder head bolts and adjust the valve clearances.
9. Check the front hub for end-play.
10. Replace oil in the front axle differential case and the front gear case of the 4-wheel drive tractor.
11. Check and replace the battery electrolyte.

## 50 HOURS SERVICE FOR A TRACTOR THAT IS NOT NEW

1. Cleaning the air cleaner element  
Thoroughly clean the element using compressed air. Wipe dust off the dust pan and body. (See SECTION 3. SERVICE INFORMATION)

2. Brake adjustment  
Adjust the brakes so that the right and left brake pedals operate the brakes evenly. Adjust the pedals so that they have the proper free play. (See SECTION 3. SERVICE INFORMATION)
3. Clutch adjustment  
Adjust the clutch pedal so as to obtain proper free play.  
(See SECTION 3. SERVICE INFORMATION.)
4. Cooling water replenishment  
Check that the specified quantity of cooling water is put in and if it is not, fill with water up to 1 inch (25.4 mm) below the filler cap.  
The maximum level of cooling water cannot be filled up in one operation. When cooling water has been completely drained, fill with new water, then run the engine at low rev. for a short period and then fill to the specified level again.  
Check the water hose for damage and inspect joint sections for leaks.

**NOTE:** \_\_\_\_\_

In cold weather, check the specific gravity of the antifreeze water mixture.

---

5. Tightening nuts and bolts  
Tighten all nuts and bolts as much as possible because vibration is always noticed when the tractor is operated. At the same time, check the ballast weight bolts for tightness.
6. Greasing  
See page 35, "Greasing diagram".
7. Checking the front hub for end-play.
8. Washing the fuel filter
9. Checking and replacing the battery electrolyte.

## B-SERVICE (Every 100 hours of operation)

**NOTE:** \_\_\_\_\_

Carry it out at the same time as DAILY INSPECTION AND A-SERVICE

---

1. Replacing the engine oil  
The engine oil should be replaced at the first 50 hours service and again replaced after 50 hours running.  
Thereafter, replace the oil every 100 hours of operation.
2. Replace the engine oil filter with a new one.
3. Check the specific gravity of the battery electrolyte.

### C-SERVICE (Every 300 hours of operation)

Carry out as follows along with DAILY INSPECTION, A-SERVICE and B-SERVICE.

1. Checking injection nozzle  
Checking the nozzle condition and injection pressure.
2. Replacing the transmission case oil
3. Washing the hydraulic oil filter
4. Replacing the oil in the front axle differential case and the front gear case of the 4-wheel drive tractor
5. Check the rear axle housing case oil.

### D-SERVICE (Every 600 hours of operation)

Carry out as follows at the same time as DAILY INSPECTION, A-SERVICE, B-SERVICE and C-SERVICE.

1. Replace the rear axle housing case oil.
2. Replace the air cleaner element.  
The element is usually replaced every 600 hours, but, for different operating conditions, judge the timing of the replacement by inspecting the element.
3. Replace the cooling water.
4. Clean the outside of the radiator.

No.	Items	Maintenance Interval												Thereafter every
		50	100	150	200	250	300	350	400	450	500	550	600	
1.	Engine oil replacement	●	●		●		●		●		●		●	100
2.	Engine oil filter element replacement	●	●		●		●		●		●		●	100
3.	Engine fuel filter element cleaning-up and replacement	○	○	○	●	○	○	○	●	○	○	○	●	○ 50 ● 200
4.	Air cleaner element cleaning-up and replacement	○	○	○	○	○	○	○	○	○	○	○	●	○ 50 ● 600
5.	Injection nozzle pressure check						⊕						⊕	300
6.	Transmission oil replacement	●					●						●	300
7.	Hydraulic oil filter element cleaning-up	○					○						○	300
8.	Rear axle housing case oil check & replacement.	⊕					⊕						●	⊕ 300 ● 600
9.	4-wheel front axle diff. case and front gear case oil check and replacement	⊕					●						●	300
10.	Specific gravity of battery electrolyte check	⊕	⊕		⊕		⊕		⊕		⊕		⊕	100

- .....Replacement
- .....Clean up
- ⊕.....Check

**NOTE:**

It is advised the intervals mentioned in the above list regarding replacing, cleaning-up and checking are for the standard cases and then desired to make each work so as to meet the requirement depending upon the usage condition of the tractors.



Application	Air Temperature	A.P.I. classification	Grade	Mobil	Esso	Shell
Engine	Below 20°F (-7°C)	CC CD	Multigrade SAE 10W	Mobil Delvac 1210	Esso LUBE D-3 10W Esso LUBE HDX 10W Esso LUBE HD 10W	Shell myrina oil 10W Shell Rimula CT 10W Shell Rotella TX 10W-30 Shell Rotella SX 10W
	20°F to 90°F (-7°C to 32°C)	CC CD	Multigrade SAE 20 SAE 20 SAE 30	Mobil Delvac 1220 Mobil Delvac 1230	Esso LUBE D-3 30 Esso LUBE HDX 30 Esso LUBE HD 30	Shell myrina 30 Shell Rimula CT 30 Shell Rotella TX 30 Shell Rotella SX 30 Shell Multigrade 20W-40
	Above 90°F (32°C)	CC CD	Multigrade SAE 40	Mobil Delvac 1230	Esso LUBE D-3 40 Esso LUBE HDX 40 Esso LUBE HD 40	Shell myrina oil 40 Shell Rimula CT 40 Shell Rotella TX 40 Shell Rotella SX 40
Transmission Hydraulic system and Steering gear box	Below 20°F (-7°C)	SAE #80		Mebilfluid-423 or Mobil A.T.F.-220	Essolub HDX 10W or Essolub XD3-10W	Dentax 80
	20°F to 90°F (-7°C to 32°C)					
	Above 90°F (32°C)			Mobilube C80	Esso Gear Oil GP80	Dentax 90
Rear axle housing		SAE #250				
4-wheel diff. case. Front king pin case		SAE #80 or #90		Mobilube GX	Esso gear Oil GP80 or 90	Shell Super deluxe EP
Antifreeze				Parmagone	Esso Antifreeze	Shell Antifreeze

RECOMMENDED LUBRICANTS AND FUEL

# GREASING DIAGRAM

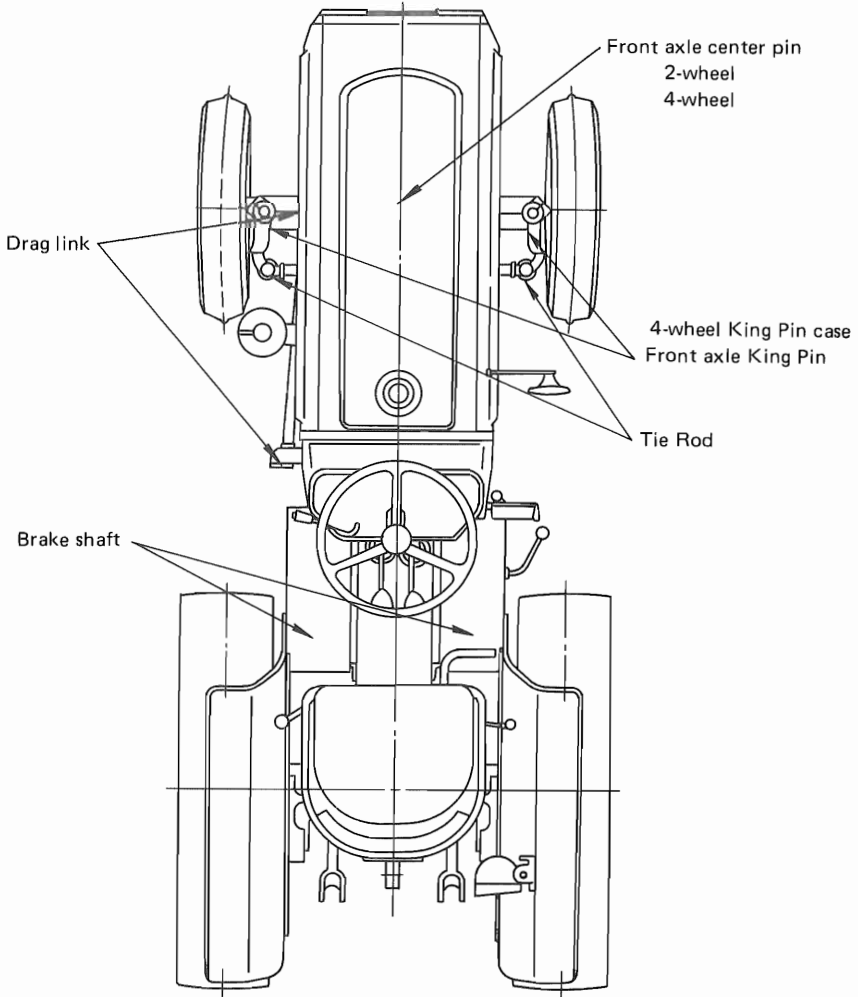

**NOTE:** \_\_\_\_\_  
Two grease nipples are fixed on the counter shaft support for front drive of four-wheel drive.  
Specially, grease enough into the rear grease nipple (Mid. PTO case side).

## SECTION 3. SERVICE INFORMATION

This section describes service information required for regular maintenance and adjustment and also the ways to carry out these jobs.

**NOTE:** \_\_\_\_\_

When carrying out the maintenance services or adjustments, place the tractor on as open and level ground as possible. Before removing caps, plugs, and covers, wipe clean the surrounding surfaces so as not to allow dust or dirt to enter the inside of the engine and the tractor.

---

### PRECAUTIONS ON COOLING SYSTEM IN COLD WEATHER

Frozen cooling water may damage the cylinder block. To avoid such a trouble, mix antifreeze into cooling water, or thoroughly drain cooling water from the cylinder block in case the tractor is stored or not used for a long time in cold weather.

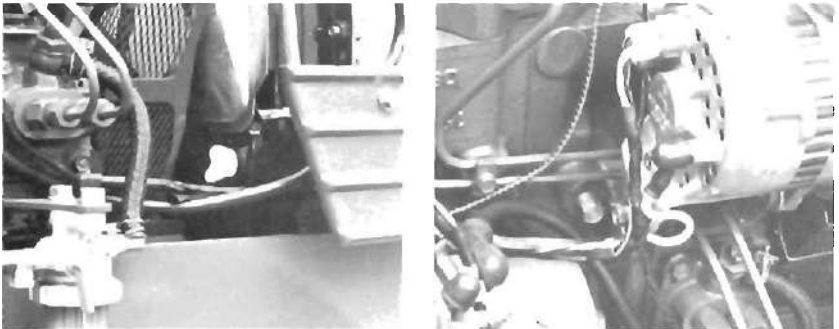

### ANTIFREEZE

When adding antifreeze solution, the following rules should be observed, otherwise, the cylinder block will rust.

1. This tractor's engine is of a diesel type and its cylinder block is made of cast iron. Therefore, suitable antifreeze solution for such a cast engine block must be used.
2. Before adding mixture of antifreeze and water, completely drain cooling water and clean the radiator with detergent.

3. Water to be added to antifreeze should be clean and soft water.
4. When antifreeze is no longer used, drain and wash the cooling system using detergent and fill it again with clean water. Do not re-use antifreeze drained from the engine.
5. Treat antifreeze carefully so that it may not remove paint from the cylinder block.
6. Any antifreeze solution (antifreeze and water), even if it is permanent antifreeze, should not be used for more than 2 years.
7. Confirm that there are no leak from the hose joints or cylinder head gasket.
8. Antifreeze with proper density to suit the climate in your area should be used.
9. When antifreeze is used over a long period in winter, measure the specific gravity frequently.

**NOTE:** \_\_\_\_\_

Consult your dealer concerning detergent and antifreeze.

---

## FUEL SYSTEM AIR BLEEDING

If fuel is exhausted the engine stops or when the fuel filter element is cleaned, air is induced into the fuel line. In such a case, the fuel system must be bled after refilling the fuel tank. If air is left in the fuel line, the engine cannot be started.

## FUEL FILTER AIR BLEEDING

Fill the fuel tank up to the proper level. Loosen the air vent screw of the fuel filter case. When the fuel starts overflowing from the screw hole, tighten the screw.

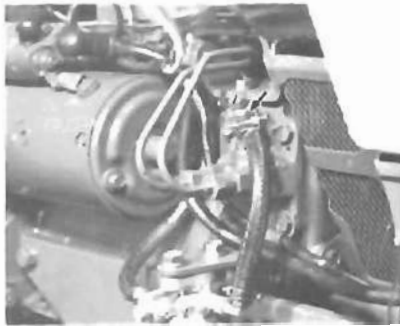
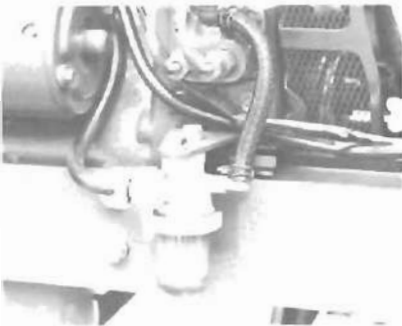

#### FUEL PUMP AIR BLEEDING

Loosen the air vent screw of the fuel pump to let the fuel to overflow. When no more air bubbles in the fuel, tighten the screw.

#### FUEL PIPE AIR BLEEDING

Loosen the nut of the nozzle and shift the throttle lever to the high speed position. Then, start the engine and make sure the fuel is discharged properly at the loosened nozzle connection. Tighten the nut to the specified torque.

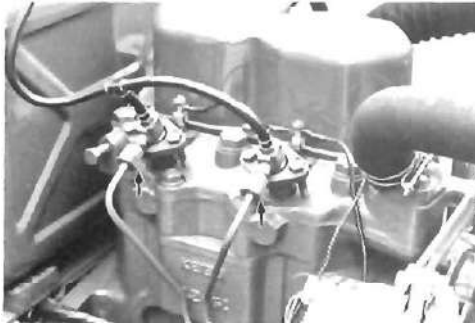

Start the engine according to the steps covered by "Starting the Engine".

**NOTE:** \_\_\_\_\_

Unless air is completely bled, the engine can not be started; in such a case, perform air bleeding again to let remaining air completely out of the system.

---

#### ENGINE OIL REPLACEMENT

Remove the plug of the engine oil pan and completely drain the used oil. Supply the specified oil up to the specified level. It should be noted that dirty oil is more easily discharged when it is warm.

Replacing engine oil should be carried out while the tractor is placed horizontally.

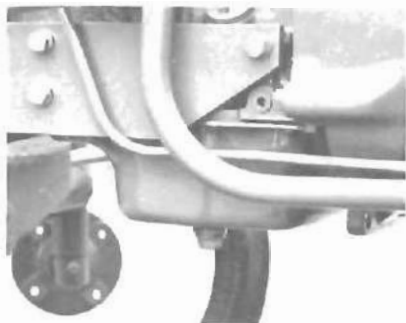

## INJECTION NOZZLE INSPECTION

When the injection pressure of the nozzle is lowered or injection deteriorates, the exhaust gas becomes extremely black resulting in the loss of engine power and the engine will also make more noise. Be sure to always maintain the correct injection pressure [ 1706 psi. ( 120 kg/cm<sup>2</sup> ) ].

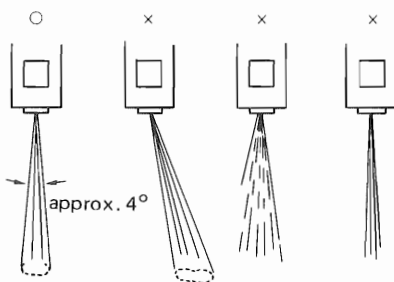
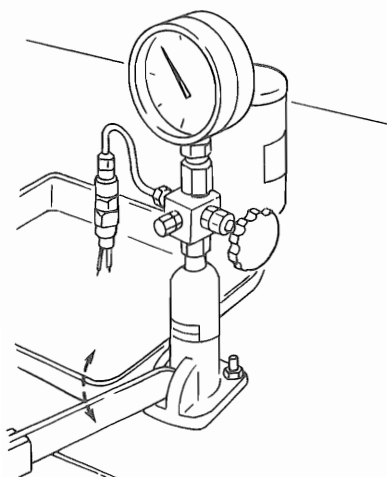

## CYLINDER HEAD BOLT TIGHTENING

Tighten the cylinder head bolts of a new tractor after 50 hours operation. When the old gasket has been replaced with a new one, tighten the bolts to the specified torque.

Tightening torque of the cylinder head bolts is 93.9–101 ft·lb (13–14 kg·m).

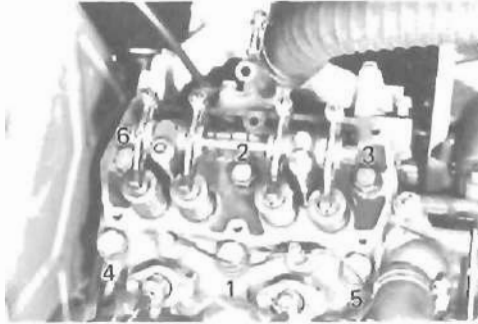

Tightening torque: 13 ~ 14 kg·m

Bolt tightening sequence is as shown in the Fig. 53. For even tightening of the bolts, the first tightening should be half the specified torque. Then tighten it further until the specified torque is obtained.

**NOTE:**

After tightening the cylinder head bolts, adjust the valve clearances.

## VALVE CLEARANCE ADJUSTMENT

Adjust the valve clearances when the sound of the tapets is loud or when the engine does not run smoothly without anything abnormal with the fuel system.

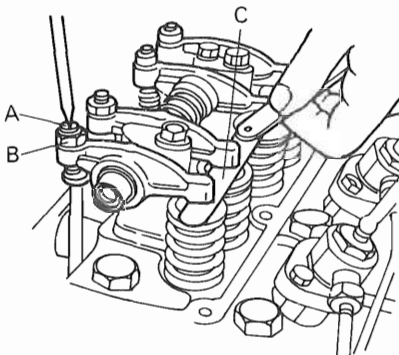

Adjust the valve clearances by loosening the lock nut (B), the adjusting screw (A) using a screwdriver and then applying a thickness gauge to (C). When locking the adjusting screw by means of the lock nut (B), support the adjusting screw firmly using a screwdriver so that both are not rotated together.

Valve clearance:

0.0138 inch (0.35 mm)  
in cold seasons

## TIMING ADJUSTMENT PROCEDURE

- Position the piston in No. 1 cylinder at top dead center on compression stroke and adjust its intake and exhaust valve clearance.
- Then rotate the crankshaft 360° clockwise to move the piston of No. 2 cylinder to top dead center on compression stroke, and adjust its valve clearance.

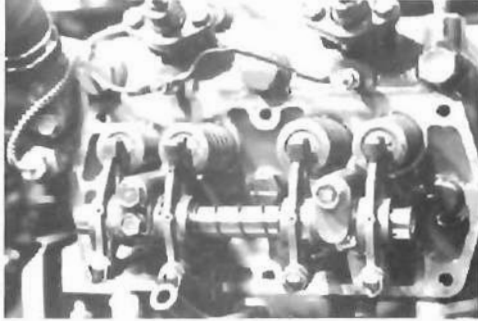

## COOLING SYSTEM

Soft water must be used for cooling except when antifreeze or antirust agents are used. Make sure that the hose joint is firmly tightened so that there is no water leakage. The front of the radiator is provided with screen to prevent dust from entering. After working in dusty places cleaning is required.





## AIR CLEANER

The air cleaner currently used on the KE engine is of a cyclon filter type with a washable paper element. The filter depends on cyclonic action to separate dirt particles from the air. During normal operation, the filter will gradually become clogged by dirt particles they have trapped.

An excessive fuel consumption or loss of power may sometimes be caused by a clogged air filter. To service the air filter, remove the dust pan and then loosen the center bolt. After lifting out the element, blow off accumulated dust by applying a jet of air from the inside of the element.

The element may be washed in water or in household cleaning liquid. Before installing, be sure that it is clean and dry. Do not forget to clean the dust pan whenever the air filter is serviced.

### NOTE:

1. When operating in extremely dusty or sandy conditions, service the filter more frequently than specified.
2. Clean the element with compressed air below 100 PSI (7 kg/cm<sup>2</sup>).



## ENGINE OIL FILTER REPLACEMENT

When necessary, the cartridge type engine oil filter is removed with the special tool and replaced with a new filter.



## NOTES:

---

1. Lightly apply the engine oil or grease to the seal surface of the oil filter before mounting.
  2. After the oil filter has been screwed in and the rubber seal comes in contact with the case surface, screw in the filter 2/3 turn further by hand.
  3. After mounting, start the engine and inspect the seal surface for leaks.
- 

## FUEL FILTER ELEMENT REPLACEMENT

The cartridge type fuel filter element is installed in the fuel filter cap. When replacing the element, remove the filter cap by loosening the filter ring so that the fuel does not flow out, and then remove the element for replacement.

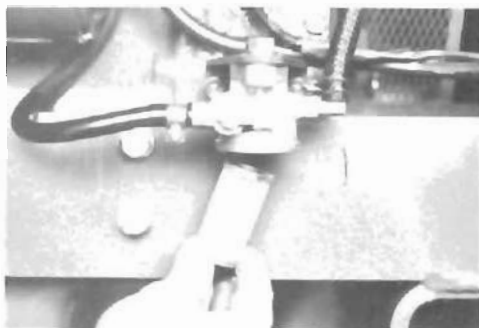

## TRANSMISSION CASE OIL REPLACEMENT

Remove the cover and the gasket by loosening the four bolts provided at the right lower part of the transmission case and drain the oil. The drain plug is also provided on each of the right and left final drive cases. It should be removed when draining the oil.

Oil replacement can be carried out easily and effectively while the oil temperature remains high.

After the oil has been drained thoroughly, tighten the drain plugs to the specified torque and pour the specified oil up to the specified level through the oil inlet provided on the upper part of the transmission case. Check the oil level with the oil gauge plug provided at the right hand of the transmission case.



**NOTE:** \_\_\_\_\_

When replacing the transmission oil, it is necessary to clean the oil filter element at the same time.

---

## REAR AXLE HOUSING CASE OIL REPLACEMENT

Remove the drain plug at the bottom of the rear axle housing and drain oil. After draining, tighten the plug securely and fill in fresh oil through the oil inlet.

## WASHING HYDRAULIC OIL FILTER

Remove the filter at the time of draining the transmission case oil, and clean the filter.

Right after the transmission case oil has been thoroughly drained by removing the drain hole cover, remove the oil filter and wash it clean. After washing, install the filter in the reverse order of removal. Be sure to install the cover firmly so that oil will not leak.

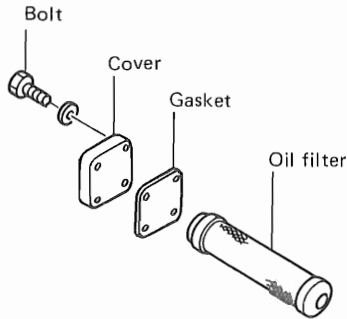

### NOTES:

1. If the transmission oil drained has to be reused, wipe clean the surrounding surfaces of the drain cover before draining, so that dust or dirt will not get into oil.
2. Oil replacement should be carried out every 300 hours under normal operating conditions. If oil deteriorates excessively, replace it earlier than specified.
3. For installing of the oil filter make sure that the tip end of the filter is securely inserted into the hole beside the suction pipe, and then install the cover.

## REPLACEMENT OF 4-WHEEL DRIVE FRONT AXLE OIL

### REPLACEMENT OF FRONT AXLE DIFFERENTIAL CASE OIL

Remove the drain plug at the bottom of the front axle differential case and drain oil. After draining, tighten the drain plug securely and pour fresh oil through the oil inlet.



### REPLACEMENT OF FRONT KING PIN GEAR CASE OIL

Remove drain plugs on the right and left front gear cases and drain oil. After draining, tighten plugs securely and pour fresh oil through the oil inlet up to the specified level.



### REPLENISHMENT OF KING PIN GEAR CASE GREASE

Remove the grease tap of the king pin case and replenish grease by the grease pump.



## CLUTCH PEDAL ADJUSTMENT

Clutch pedal free play is very important and it must be always maintained to be correct. If there is no free play, the clutch disc will wear quickly, while too much free play will cause difficult disengagement of the clutch even if the pedal is fully depressed, resulting in hard gear shift.

### FREE PLAY ADJUSTMENT

The free play in the clutch pedal should be between 0.394 and 0.787 inch (10 and 20 mm).

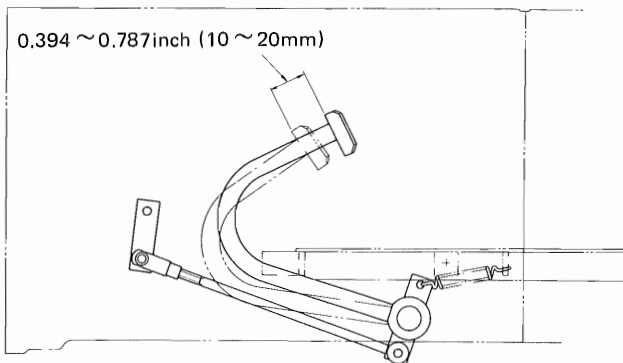

Pull out the clutch pedal shaft and the clutch rod set pin, and then adjust the clevis so that the pedal free play becomes 0.394 – 0.787 inch (10 – 20 mm).

**NOTE:** \_\_\_\_\_

This adjustment is important for maintaining the clearance between the release lever and the release bearing to obtain a smooth gear shift and transfer all the driving power to the transmission.

---

## BRAKE PEDAL ADJUSTMENT

Free play of the brake pedal must be maintained within the correct range, otherwise, accidents may occur or power will be lost.

Before the brake on one side becomes unadjustable even by means of the rod, caused by earlier wear of the brake living due to its more frequent use than the other, periodically interchange the right and left brake shoes.

### FREE PLAY ADJUSTMENT

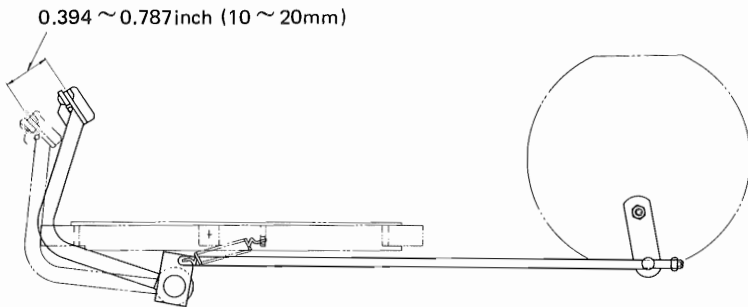

1. Adjust the brake rod adjusting nut so that the pedal free play will be 0.394 ~ 0.787 inch (10 ~ 20 mm).
2. Confirm that the right and left brakes operate simultaneously by running the tractor. If not adjust both of them by means of the rod.

**NOTE:** \_\_\_\_\_

When running on roads, make sure that the right and left brake pedals are linked.

---

## THROTTLE LEVER ADJUSTMENT

For controlling the engine speed the throttle lever and the foot throttle pedal are provided, which are located on the instrument panel and on the right front of the step, respectively.

These two controls should always be kept adjusted so that the engine on S-630 and S-630D will be properly operated within the following speed range:

Low idle speed: 750 ~ 800 rpm

High idle speed: 2650 ~ 2700 rpm

1. Move slowly the throttle lever forward and backward. Leave the lever at such a position that a slight resistance can be felt.
2. Remove the clevis set pin connecting the governor lever to the rod. Loosen the lock nut and turn in or out the adjusting nut so that the engine speed meter on the instrument panel shows, the low idle speed of 750 ~ 800 rpm. After correct adjustment is made, tighten the lock nut securely and install the clevis set pin.

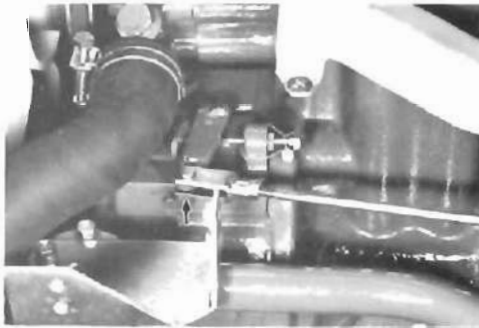

3. Pulling the throttle lever fully backward allows the engine to run at the maximum of 2,700 rpm.
4. Pushing the throttle lever fully forward causes the engine to stop running.

### NOTES:

1. The adjusting bolt is pre-adjusted, before leaving the factory, so that the engine runs at the maximum speed specified with the throttle lever pulled fully backward. If such specified speed is not obtained, consult your SATOH distributor.
2. Adjust the governor spring tension by the tension adjusting nut on the end of the throttle lever so that the throttle lever operates



smoothly and steadily, keeping free from loose movement caused by vibration or by pressure of the spring.

---

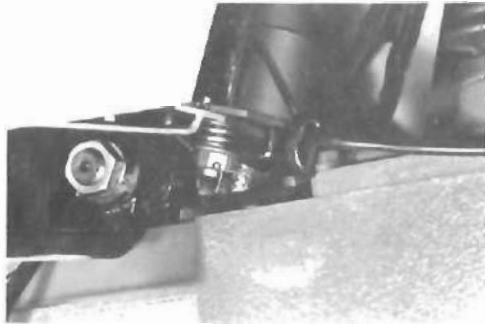

## FOOT THROTTLE PEDAL ADJUSTMENT

After adjusting the throttle lever idling on the instrument panel shift the throttle lever to "STOP", provide the gap of approximate 0.04" (1 m/m) between the stopper on the wire tip top and the rod and then lock it.

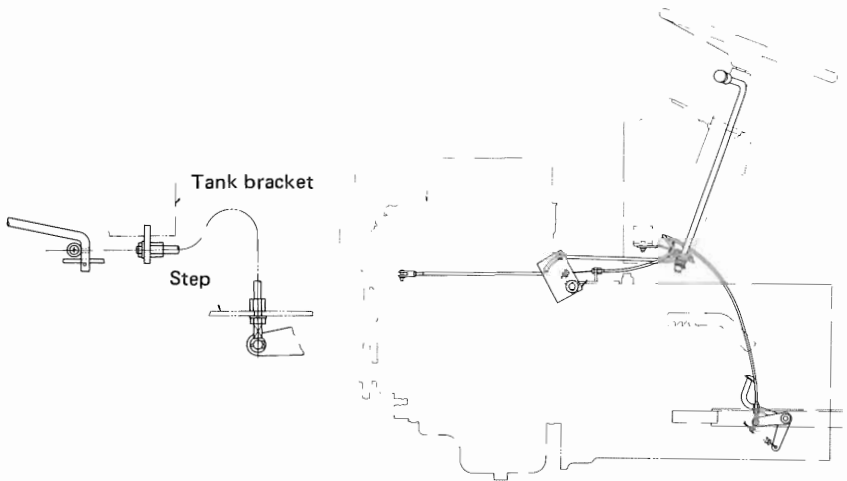

## FAN BELT TENSION ADJUSTMENT

Proper fan belt tension is 0.4 ~ 0.51 inch (10 ~ 13 mm) with a thumb pressure halfway between the water pump pulley and alternator pulley. To adjust the tension, loosen the alternator bracket bolt and the adjust plate bolt and move the alternator in or out. After proper tension is obtained, tighten the bolt securely. Check the belt for cracks and damages.

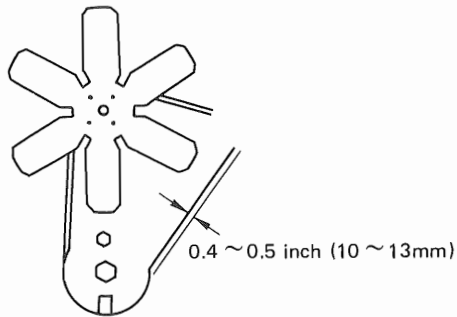

## DIFFERENTIAL LOCK PEDAL ADJUSTMENT

Loosen the lock nut on the differential lock pedal stopper, and screw in the stopper bolt. With the pedal depressed, adjust the stopper bolt so that it lightly contacts the pedal. Then, screw out the stopper bolt 0.2 ~ 0.4 inch (5 ~ 10 mm) off the pedal and lock the stopper bolt.

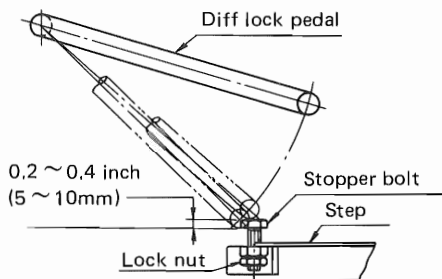

## HYDRAULIC CONTROL ADJUSTMENT

The hydraulic system of the SATOH tractor is adjusted and tested before it leaves the factory and needs no more adjustment in the field. Should it, however, show unsatisfactory operation, adjust it in the following manner:

○In case the safety valve is operated all the times.

Slide the stopper forward to be set at such a position that the valve can not be actuated even with the control lever shifted to the full "lift" position. No adjustment is required for lowering operation.

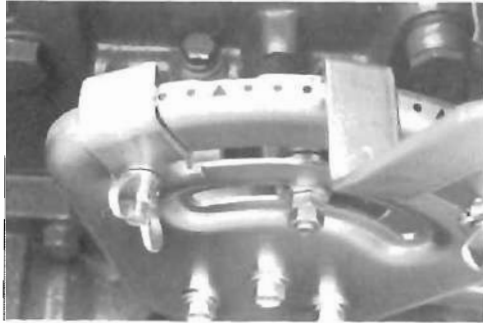

## FLOW CONTROL LEVER ADJUSTMENT

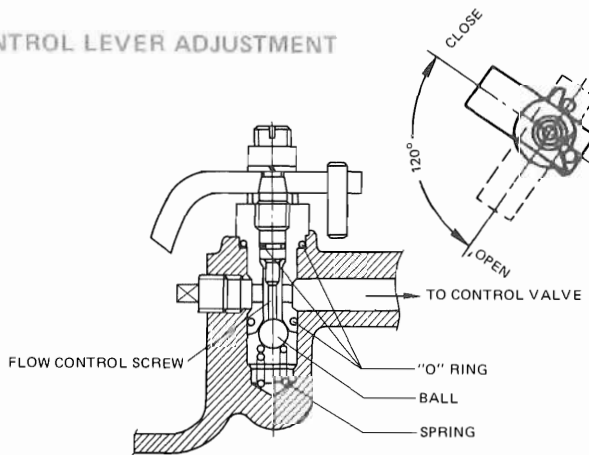

Remove the pivot screw lock nut and then the lever stopper. Turn the pivot screw clockwise about 3 turns, start the engine and lift the implement. Then, stop the engine and shift the hydraulic control lever to the lowering position. Under this condition, make sure the implement is firmly locked. (If the implement lowers, turn the pivot screw clockwise

further until the implement is locked.)

Turn slowly the pivot screw counterclockwise. When the implement starts lowering, stop turning the pivot screw and install the lever stopper in the position as shown in the illustration and lock the stopper securely with the lock nut.

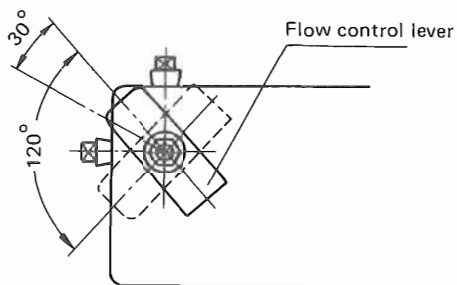

Turn the lever stopper clockwise until it stops turning and make sure the implement is completely locked.

## HYDRAULIC PUMP RELIEF VALVE

The hydraulic system on S-630 and S-630D is equipped with a pump relief valve to protect the hydraulic pump and pipe line against accidents caused by high hydraulic pressure in the system. The set pressure is 1849 psi (130 kg/cm) at full flow. Never disturb nor disassemble the pump relief valve since its adjustment requires special tools and instruments.

## HYDRAULIC CYLINDER RELIEF VALVE ADJUSTMENT

The piston is equipped with cylinder relief valve to protect the hydraulic system from shocks caused by an implement mounted on the 3 point linkage when the tractor is running on a rough road. The set pressure is 3555 psi (250 kg/cm<sup>2</sup>). Disassembling for adjustment should be avoided because it cannot be carried out without facilities or gauge.

## EXTERNAL HYDRAULIC SERVICE

Adjustment will not probably be required; but, if it is necessary consult your SATOH dealer.

## FRONT AXLE CENTER PIN AND FRONT HUB

A heavy load is always applied to the front axle center pin; therefore sufficient grease is always required at this point. Check the pin for deterioration at frequent intervals.

The front hub has been lubricated with grease and carefully assembled in the factory. However, further checking every 50 hours is required.

When grease is insufficient or pre-load is incorrect supply more grease or adjust the pre-load.

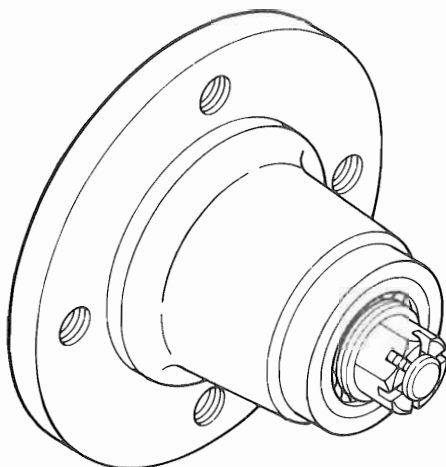

## BATTERY

### NOTE:

The electrical system on S-630 and S-630D is of negative earth type. Care should be taken to ensure that the battery terminals are correctly connected when installing the battery.

The battery equipped is YUMICRON battery model Y100-S6.

Though small-sized, it shows 40% high performance as compared with the conventional batteries of the same size.

Offering some 100AH of engine starting energy, the Y100-6S battery powers the engine effectively specially in cold weather.

Daily checking and servicing is the same as for previous batteries.

- The specific gravity of the electrolyte is  $1.280 \pm 0.010$  at  $68^{\circ}\text{F}$  ( $20^{\circ}\text{C}$ ).

- The amount of electrolyte should be between the lower and upper levels indicated on the outside of the battery case. Particularly in hot weather, frequently check the level of battery electrolyte.



**NOTE:** \_\_\_\_\_

Usually, battery electrolyte will not freeze. However, when the specific gravity is lowered, the fluid will freeze more easily. Don't forget to turn off the lamp and don't treat the battery in such a way as the battery is discharged rapidly. In particular, when the battery is not used for a long period of time in cold weather, check the specific gravity and charge the battery periodically.

---

If the battery has to be recharged, a slow-charging operation should be carried out at the lowest possible charging rate (so much as 3AH for Y100-S6 47AH battery).

If the specific gravity of the electrolyte reads less than 1.200, the battery should slow-charged but never quick-charged.

For more information, consult your Satoh dealer or distributor.

## AC GENERATOR

Generator installed on S-630 and S-630D is an alternator type. Sealed bearings are employed in this generator, so that lubrication is not necessary.

During maintenance, pay attention to the following points.

1. The generator is negative-grounded and if the polarity is reversed, the diode will be damaged. Be careful enough when connecting it to the battery.
2. As the battery voltage is always connected to terminal A, never run the engine with terminal A disconnected.

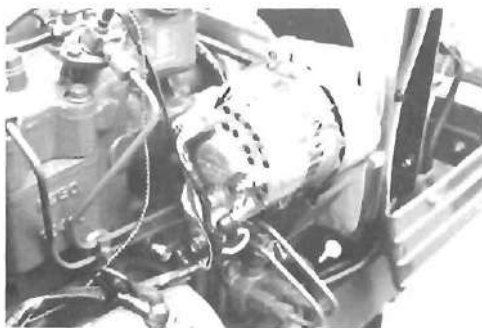

3. Don't water the alternator at high pressure.
4. Pay full attention to the belt tension so that normal charging may be made.
5. If difficulties are experienced, consult your SATOH dealer.

## STARTER MOTOR

Facilities and instruments are necessary for servicing the starter motor. When the rotational force of the motor is weak, measure the battery voltage because it may be caused by insufficient battery capacity. When the voltage is correct and there is still inferior rotation, let your SATOH dealer check the carbon brushes for deterioration and magnetic switch for defective performance. The motor sometimes does not start even when the light is sufficiently bright. The cause may be due to trouble in the regulator or a loose battery terminal connection.

When the starter motor does not operate, don't continue to drive it because it will result in damage to the motor or battery. In this case, consult your SATOH dealer.

## REGULATOR

The regulator is an important part for the electrical system protection of your tractor. When trouble occurs with the regulator, consult your SATOH dealer because specific knowledge and special instruments are required to repair it.

## GLOW PLUG

The glow plugs are of a sheathed type and connected in parallel. Therefore, if one of the plugs is disconnected, performance is not totally defective. When the heat wire of the glow plugs is disconnected, the pre-heat time of the control resistance is abnormally prolonged. When the center polarity, the body and the sheath come in contact with one another, the glow signal lamp will be heated quickly and the wiring of the pre-heated circuit will burn out.

Consult your SATOH dealer when trouble with the glow plug is experienced.

## FUSE BOX

The fuse box is installed on the skirt of the instrument panel to protect the wiring. One of the two 15A fuses protects the head lamp and working lamp. The other protects the warning lamps in the meter. A spare fuse is provided in the fuse box.

## SAFETY STARTER SWITCH ADJUSTMENT

After adjusting clutch pedal free play properly, make adjustment of the safety starter switch using adjusting nuts so that its front end is 0.16 in. (4mm) above the safety starter switch setting bracket clutch pedal stopper, and then lock it securely to the bracket.

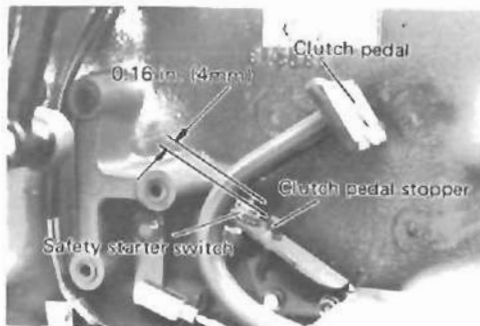

Upon completion of adjustment, confirm that the starter motor does not rotate when the clutch pedal is released.



# Circuit diagram

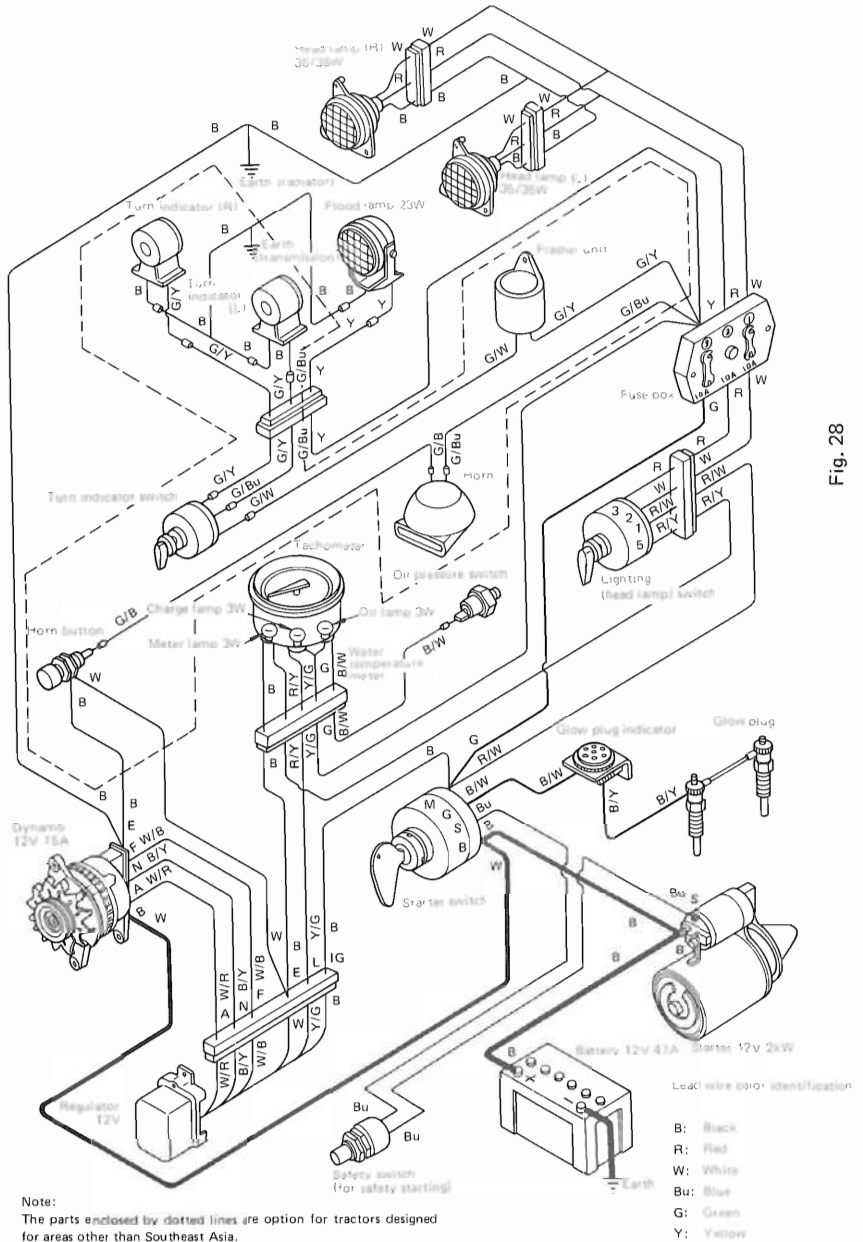

Fig. 28

## SECTION 4. SPECIFICATIONS AND DATE

### ENGINE

Model . . . . .	KE130-13B
Number of cylinder . . . . .	2
Cylinder arrangement . . . . .	In line
Piston displacement . . . . .	76.0 cu. in (1,246 cc)
Bore x Stroke . . . . .	3.543 x 3.74 in (90 x 95 mm)
Rated rpm . . . . .	2,500 rpm
Max. rpm . . . . .	2,700 rpm
Idling speed . . . . .	750 ~ 800 rpm
Max. bear Hp/rpm . . . . .	25 Hp/2,500 rpm
Max. torque . . . . .	51.3 ft-lb (7.1 kg-m) 2,000 rpm
Compression ratio . . . . .	21 : 1
Compression pressure . . . . .	455 psi (32 kg/cm <sup>2</sup> )
Injection order . . . . .	1. 2.
Valve position . . . . .	Overhead valve system
Weight . . . . .	352.8 lb (160 kg)
Valve clearance (Intake and Exhaust) . . . . .	0.0138 in (0.35 mm) in the cold district

### COOLING SYSTEM

Thermostat type . . . . .	Wax. type
Radiator cap pressure . . . . .	12.8 psi (0.9 kg/cm <sup>2</sup> )
Water pump type . . . . .	Centrifugal impeller type
Temperature at which thermostat begins to open . . . . .	180°F (82°C)
Temperature at which thermostat is fully opened . . . . .	203°F (95°C)

### FUEL EQUIPMENT

Fuel . . . . .	Diesel fuel
Fuel injection pump . . . . .	Bosh K. type
Fuel filter . . . . .	Paper element filter cartridge type
Injection nozzle . . . . .	Pintle type

### LUBRICATION SYSTEM

Oil pump . . . . .	Trochoid pump
Oil filter . . . . .	Paper element filter cartridge type

### AIR CLEANER

Type . . . . .	Dry paper element cartridge type
----------------	----------------------------------

## GOVERNOR

Type . . . . . Centrifugal all speed control type

## ELECTRICAL SYSTEM

Battery (Yumicron) . . . . . Y100-S6 12 Volt 47 AH

Generator . . . . . Alternator (AC) type

Starting motor . . . . . Magnet type 12 volt 2 kw

## PERFORMANCE CURVE

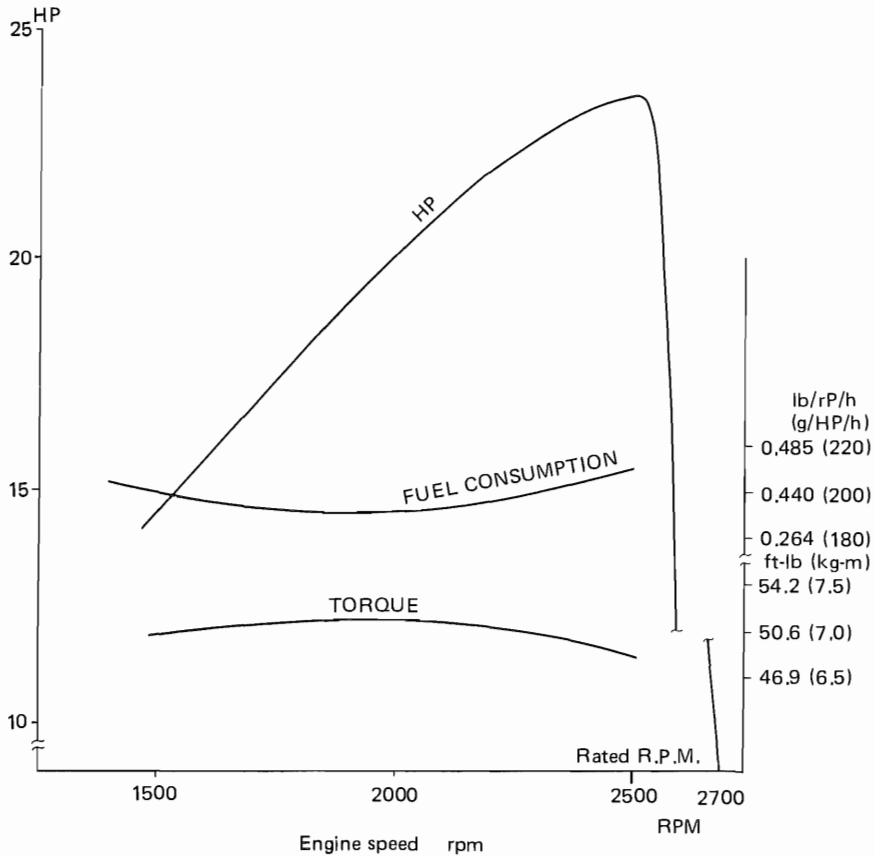

## GLOW PLUG

Type . . . . . Sheathed type

## DIMENSIONS OF STANDARD TYPE

### Overall length

End of 3-point linkage . . . . . 104.72 in (2,660 mm)

End of rear tire . . . . . 96.46 in (2,450 mm) (2-wheel & 4-wheel)

Overall width . . . . . 49.80 in (1,265 mm)

### Overall Height

Top to muffler . . . . . 77.56 in (1,975 mm)

Top to steering wheel . . . . . 55.12 in (1,400 mm)

Wheel base 2-wheel drive . . . . . 60.00 in (1,524 mm)

4-wheel drive . . . . . 60.00 in (1,524 mm)

Ground clearance 2-wheel drive . . . 16.14 in (410 mm) (under front axle)

4-wheel drive . . . 11.61 in (295 mm) (under front axle)

Weight 2-wheel drive . . . . . 2004.4 lb (910 kg)

4-wheel drive . . . . . 2137.0 lb (970 kg)

### Turning radius (with brakes)

2-wheel drive . . . . . 90.55 in (2,300 mm)

4-wheel drive . . . . . 96.46 in (2,450 mm)

## CLUTCH

Type . . . . . Dry single disc plate type

### Clutch disc dimension

(outer x inner x thickness) . . . 8.27 x 5.91 x 0.31 in  
(210 x 150 x 7.8 mm)

## TRANSMISSION

Number of shift lever . . . . . 2

Speed steps . . . . . 9-forwards 3-reverse

Speed change method . . . . . Selective sliding gear

Differential gear . . . . . Bevel gear type

Differential lock . . . . . With differential lock

## POWER TAKE OFF

Max P.T.O. horse power . . . . . 22.0 Hp/2,500 engine rpm

P.T.O. Shaft . . . . . 1-3/8 in 6 spline SAE standard

Turning direction . . . . . Clockwise as viewed from the rear

Revolution First . . . . . 555 rpm/2,500 engine rpm

Second . . . . . 774 rpm/2,500 engine rpm

Third . . . . . 1,025 rpm/2,500 engine rpm

Fourth . . . . . 1,320 rpm/2,500 engine rpm

Standard P.T.O. speed . . . . . 540 rpm/2,432 engine rpm (first)  
 1,000 rpm/2,439 engine rpm (third)

## BRAKES

Type . . . . . Water proof internal expansion  
 drum type  
 Drum diameter . . . . . 6.30 in (160 mm)  
 Brake shoe  
 Length x Width x Thickness . . 7.28 x 1.18 x 0.18 in  
 (185 x 30 x 4.5 mm)  
 Parking brake . . . . . Main brake used

## STEERING

Type . . . . . Ball screw steering gear box  
 Toe-in 2-wheel drive . . . . . 0.16 ~ 0.31 in (4 ~ 8 mm)  
 4-wheel drive . . . . . 0 ~ 0.2 in (0 ~ 5 mm)

## TREAD ADJUSTMENT

Front 2-wheel drive . . . . . 42 in (1,070 mm) 46 in (1,170 mm)  
 50 in (1,270 mm) 54 in (1,370 mm)  
 56 in (1,470 mm)  
 4-wheel drive . . . . . 35.83 in (910 mm)  
 Rear 2-wheel drive . . . . . 38 in (965 mm) 40 in (1,005 mm)  
 & 4-wheel drive 44 in (1,120 mm) 45.3 in (1,150 mm)  
 45.8 in (1,165 mm) 50.4 in (1,280 mm)

## HYDRAULIC POWER LIFT

Type of hydraulic pump . . . . . Pressure loading gear type  
 Pump relief valve pressure . . . . . 1,849 psi (130 kg/cm) full flow  
 Control . . . . . Position (lifting and lowering),  
 flow and lift lock  
 Max. lift power at lower link end . . 1,453 lb (660 kg)  
 Output of pump . . . . . 2.93 gal (11.1 ℓ) /2,500 engine rpm

## 3-POINT LINKAGE

Standard of the lower links . . . . . SAE Category 1  
 Lift power of lower link end . . . . . 1,453 lb (660 kg)

## WHEEL EQUIPMENT

		Tire size	Ply	Lug pattern	Allowable load	
AG	Front	2WD	500-15	4	FSR	771 lb(350kg)
		4WD	6-14	4	AR14	660.7lb(300kg)
	Rear		11.2-24	4	FSLW	1795 lb(815kg)
ES	Front	2WD	5.90-15	4	F12	1112.3lb(505kg)
		4WD	6-14	4	FSD	661.4lb(300kg)
	Rear		11.2/10-24	4	FD	1795 lb(815kg)
WTT	Front	2WD	20x800-10	4	PD	1002 lb(455kg)
		4WD	6-14	4	FSD	661.4lb(300kg)
	Rear		13.6-16	4	FD	1652 lb(750kg)

## TRAVEL SPEED

(Tire size 11.2 – 24) at engine speed 2,500 rpm.

	Speed	Lever position	mile/h	km/h	m/sec
Max. speed	F-1	L-1	0.78	1.26	0.35
	F-2	L-2	1.05	1.69	0.47
	F-3	L-3	1.37	2.21	0.61
	F-4	M-1	2.27	3.66	1.02
	F-5	M-2	3.05	4.91	1.36
	F-6	M-3	3.99	6.42	1.78
	F-7	H-1	6.04	9.72	2.70
	F-8	H-2	8.11	13.05	3.63
	F-9	H-3	11.44	18.41	5.11
	R-1	L-R	0.88	1.42	0.39
	R-2	M-R	2.56	4.12	1.14
	R-3	H-R	6.79	10.93	3.04

## CAPACITIES (Approximate Initial Fill)

Cooling water . . . . .	1.48 gal (5.6 ℓ)
Engine oil . . . . .	1.06 gal (4.0 ℓ)
Transmission oil	
2-wheel drive . . . . .	.3.17 gal (12.00 ℓ)
4-wheel drive . . . . .	.3.17 gal (12.00 ℓ)
Hydraulic oil . . . . .	Same as transmission oil
Rear axle housing case oil . . . . .	.0.21 gal (0.8 ℓ) one side
Front diff. case oil	
4-wheel . . . . .	.0.26 gal (1.0 ℓ)
Front kingpin gear case oil	
4-wheel . . . . .	.0.08 gal (0.3 ℓ) one side
Fuel tank . . . . .	.5.28 gal (20 ℓ)

\* Specifications are subject to change without notice.

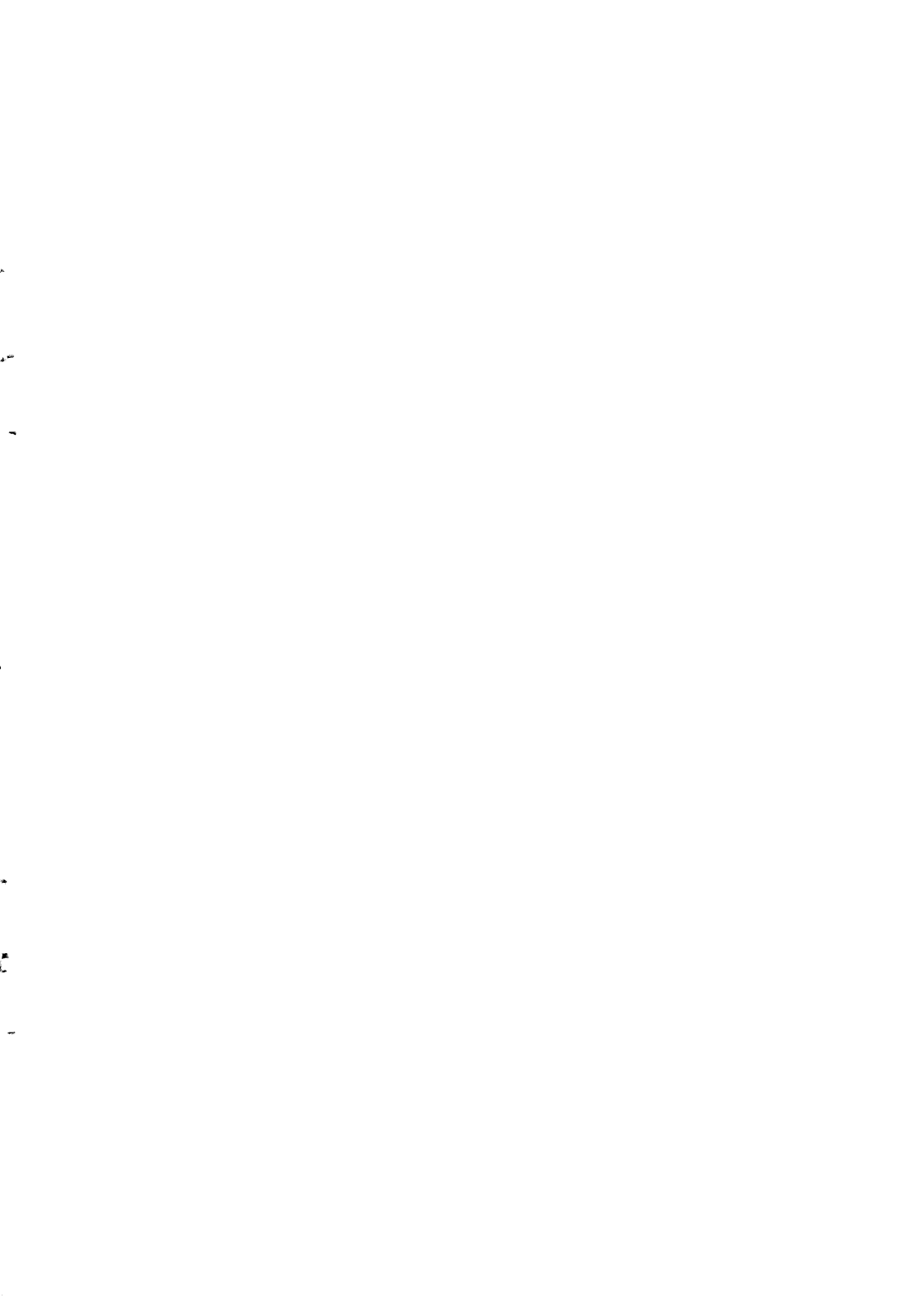

OIL CHANGE	DATE	HOURS
	1-21-83	692
1	4	
11 11	11-7-84	1141
11 5	12-20-85	1367

**SATOH** SATOH AGRICULTURAL MACHINE MFG. CO., LTD.