

**INTERNATIONAL®
274
TRACTOR**

INTERNATIONAL®

OPERATOR'S MANUAL



To The Owner

Your new International Harvester tractor is designed to meet today's exacting operating requirements. The ease and comfort of operation, the ability to match ground speeds to engine power and work requirement, and the effort less versatility of the hydraulic system are intended to lighten your work and shorten your hours on the job.

Your local International Harvester dealer is interested in the performance you receive from this tractor. He has factory trained servicemen, informed in the latest method of servicing tractors, and modern tools, and original-equipment IH service parts which assure proper fit and good performance.

To obtain top performance and assure economical operation the tractor should be inspected, depending on its use, periodically, or at least once a year, by your International Harvester Dealer.

Before you operate the tractor, study this manual carefully. It has been prepared to help you operate and maintain your tractor with utmost efficiency. New copies may be ordered from your dealer at a nominal price.

When in need of parts, always specify the tractor and engine serial numbers, including prefix and suffix letters. Write these serial numbers in the spaces provided below.

METRIC (SI) MEASUREMENTS

A standard of measurement known as International System of Units (SI) has been adopted for world-wide use. English Units followed by Metric Equivalents are used throughout this manual. (Metric Equivalents are given in parentheses.) A conversion list of commonly used measurements are listed on page 73 for your reference.

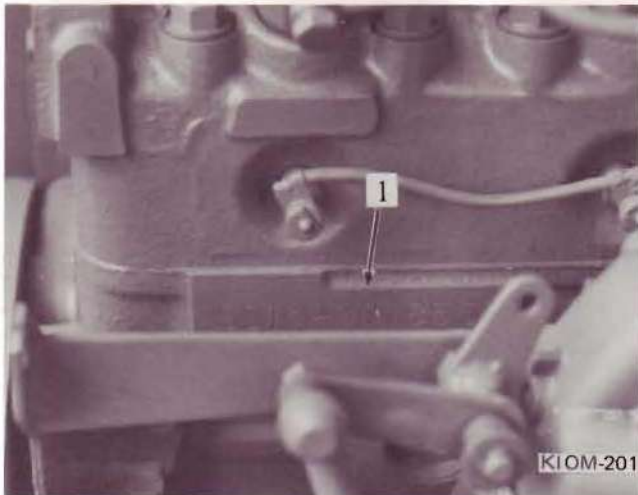

1. Engine serial number

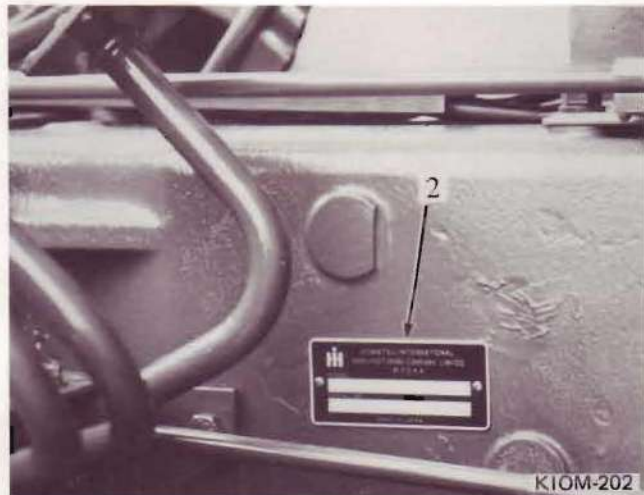

2. Tractor serial number

DELIVERY SERVICE FOR 274 TRACTOR

This form must be filled out by the dealer and signed by both the dealer and the customer at the time of delivery.

Delivered to _____ Dealer _____

Street Address _____

City _____ Serial No. _____

State _____ Zip _____ Engine Serial No. _____

I have thoroughly instructed the buyer on the above described equipment which review included the Operator's Manual content, equipment care, adjustments, and safe operation. The warranty policy provisions were also explained and reviewed.

DEALER'S SIGNATURE

Above equipment and Operator's Manual have been received by me and I have been thoroughly instructed as to care, adjustments, safe operation and applicable warranty policy.

DATE

OWNER'S SIGNATURE

----- FOLD BACK HERE AND ADD CARBON -----

DEALER'S COPY

CUT ALONG THIS LINE FIRST

DELIVERY SERVICE FOR 274 TRACTOR

This form must be filled out by the dealer and signed by both the dealer and the customer at the time of delivery.

Delivered to _____ Dealer _____

Street Address _____

City _____ Serial No. _____

State _____ Zip _____ Engine Serial No. _____

I have thoroughly instructed the buyer on the above described equipment which review included the Operator's Manual content, equipment care, adjustments, and safe operation. The warranty policy provisions were also explained and reviewed.

DEALER'S SIGNATURE

Above equipment and Operator's Manual have been received by me and I have been thoroughly instructed as to care, adjustments, safe operation and applicable warranty policy.

DATE

OWNER'S SIGNATURE

OWNER'S COPY

DELIVERY SERVICE FOR 274 TRACTOR

This form must be filled out by the dealer and signed by both the dealer and the customer at the time of delivery.

Delivered to _____ Dealer _____

Street Address _____

City _____ Serial No. _____

State _____ Zip _____ Engine Serial No. _____

I have thoroughly instructed the buyer on the above described equipment which review included the Operator's Manual content, equipment care, adjustments, and safe operation. The warranty policy provisions were also explained and reviewed.

DEALER'S SIGNATURE

Above equipment and Operator's Manual have been received by me and I have been thoroughly instructed as to care, adjustments, safe operation and applicable warranty policy.

DATE

OWNER'S SIGNATURE

REGIONAL OFFICE COPY

TECHNICAL PUBLICATIONS AVAILABLE

Your International Harvester Dealer and his factory trained servicemen are best qualified to service your equipment. Up-to-date instructions and adequate special tools are also a part of your Dealer's service facilities.

This Operator's Manual was prepared to instruct you in proper operation and maintenance of your equipment. If you desire additional information you may purchase Parts Catalog. Additional copies of the Operator's Manual are also available.

Fill out the order blank and forward together with your check or money order in the appropriate amount (U.S. Funds) to:

International Harvester Company

PRINTED AND
DISTRIBUTION SERVICES

807 Blackhawk Drive

Westmont, Illinois 60559

Attention: Cashier

Cut Along This Line

Title	Number	Q'ty.	Price Each
Operator's Manual			
274 Tractor	1 432 874 R2		7.20
Parts Catalogs			
274 Tractor	TC-196		5.10
Service Manuals			
Chassis, Engine, Fuel System and Mower	GSS-1478-1		28.40

TOTAL _____

Cut Along This Line

Please Print

Name _____

Street Address _____

City _____

State _____

Zip Code _____

Date _____

Signed _____

Do not send cash or stamps

Prices subject to change without notice.

TECHNICAL PUBLICATIONS AVAILABLE

Year	Title	Author	Price
1958
1959
1960
1961
1962
1963
1964
1965
1966
1967
1968
1969
1970
1971
1972
1973
1974
1975
1976
1977
1978
1979
1980
1981
1982
1983
1984
1985
1986
1987
1988
1989
1990
1991
1992
1993
1994
1995
1996
1997
1998
1999
2000
2001
2002
2003
2004
2005
2006
2007
2008
2009
2010
2011
2012
2013
2014
2015
2016
2017
2018
2019
2020

For International Distributor Dealer and for further technical information and data contact the nearest distributor. The nearest distributor is listed on the back cover of this publication. Write to the nearest distributor for a copy of your dealer's technical literature.

The Division's literature was prepared to assist you in your selection and purchase of your equipment. It contains technical data, operating instructions, and maintenance information. It is available to you in the form of a manual or a separate leaflet. Contact your distributor for a copy of the Division's Manual or the separate leaflet.

For a complete list of the Division's literature and for a copy of the literature, contact your distributor. The nearest distributor is listed on the back cover of this publication. Write to the nearest distributor for a copy of your dealer's technical literature.

INTERNATIONAL
DIVISION

1000 ...
... ..

... ..

CONTENTS

CONTENTS	1, 2	OPERATING THE TRACTOR	17 thru 20
INTRODUCTION	3	Starting the Tractor	
WORK SAFELY – FOLLOW THESE RULES	4 thru 6	After the Engine Starts	
INSTRUMENTS AND CONTROLS	7 thru 13	Driving the Tractor	
Brake pedals		Driving on Slopes	
Brake pedal latch		Towing the Tractor	
Park brake lever		Driving on Public Road	
Clutch pedal		Stopping the Tractor	
Auxiliary hydraulic control lever		Differential Lock (Optional)	
Drop control knob		Transporting	
Three point hitch position control lever		POWER TAKE-OFF	21, 22
Starting key switch		General	
Engine speed control lever		Operating the Power Take-Off	
Fuel shut off knob		HYDRAULIC LIFT AND HITCH SYSTEMS	22 thru 24
Glow plug signal		Three Point Hitch Position	
Low fuel indicator lamp		Control lever	
Fuse block		Auxiliary Hydraulic Control lever	
Flashing warning light switch		Adjustable Stoppers	
Head and taillight switch		Drop Control Knob	
Taillight		THREE POINT HITCH	25 thru 29
Gearshift lever		Lower Links and Upper Link	
Power take-off lever		Lower Link Adjustments	
Transmission range lever		Upper Link Adjustment	
Instrument Cluster (Tachometer, Speedmeter, Hourmeter, Water temperature tellite, Oil pressure tellite, Charge indicator tellite)		Attaching to the Tractor	
Hook open lever		Stabilizer	
OPTIONAL INSTRUMENTS AND CONTROLS	14	Uncoupling the Implement	
Differential lock pedal		Removing the Three Point Hitch Linkage	
Fixed drawbar		Installing the Three Point Hitch	
Engine coolant heater		HITCHING TRAILING EQUIPMENT TO THE TRACTOR	29, 30
BEFORE OPERATING THE TRACTOR	15, 16	FRONT WHEELS	30, 31
Lubrication		Adjusting the Tread Width	
Air Cleaning System		REAR WHEELS	32, 33
Tires		Adjusting the Tread Width	
Engine Cooling System		WEIGHTS	33 thru 35
Fuel		Front End Weights	
Adjusting the Seat		Front Wheel Weights	
Tractor Break-In Procedure		Rear Wheel Weights	

CONTENTS

PREVENTIVE MAINTENANCE GUIDE	36, 37	STORING THE TRACTOR	54, 55
		Storage	
		Removing from Storage	
PREVENTIVE MAINTENANCE	38	COLD WEATHER PRECAUTIONS	55, 56
Hood	38	Fuel System	
Fuel Shut Off Valve	39	Electrical	
Filler Cap Air Vent	39	Lubrication	
Fuel Filter	40	Cooling System	
Draining Water from Sediment Bowl	40	Engine Coolant Heater (Optional)	
Venting the Fuel System	40	LUBRICATION	56 thru 61
Cooling System	41	Checking the Oil Level	
Adding Coolant to the Cooling System	41	Engine Oil	
Cleaning the Cooling System	42	Checking the Oil Level	
Filling the Cooling System	42	Changing Engine Oil	
Fan Belt Tension	42, 43	Changing the Engine Oil Filter	
Dry-Type Air Cleaner	43, 44	Gear Lubricant	
Electrical System	45	Transmission Breather	
Charging System and Alternator		Hydraulic Fluid Filter	
Generator	45, 46	Lubrication Fitting Grease	
Lighting Switch	46	Greasing the Front Wheels	
Headlight Replacement	46	LUBRICATION TABLE	62
Flashing Warning Light	47	LUBRICATION GUIDE	63 thru 66
Taillight (Optional)	47	SPECIFICATIONS	67 thru 70
Rear Work Lamp (Optional)	47	EXTRA EQUIPMENT AND ACCESSORIES	71
Fuse	48	UNIVERSAL SYMBOLS FOR INSTRUMENTS AND CONTROLS	72
Battery	48, 49	METRIC (SI) MEASUREMENTS	73
Tellite Bulb Replacement	49, 50		
Rear Wheels	50		
Adjusting the Toe-in	50, 51		
Tires	51		
Care of Tires	51		
Inflation	51		
Shipping Tractors Equipped with Pneumatic Tires	51		
Mounting Tires on the Rim	52		
Traction and Weights	52		
Overloading	52		
Brake	52		
Brake Adjustment	52		
Park Brake Adjustment	53		
Bleeding the Brake	53		
Care and Adjustment of the Engine Clutch	54		

INTRODUCTION

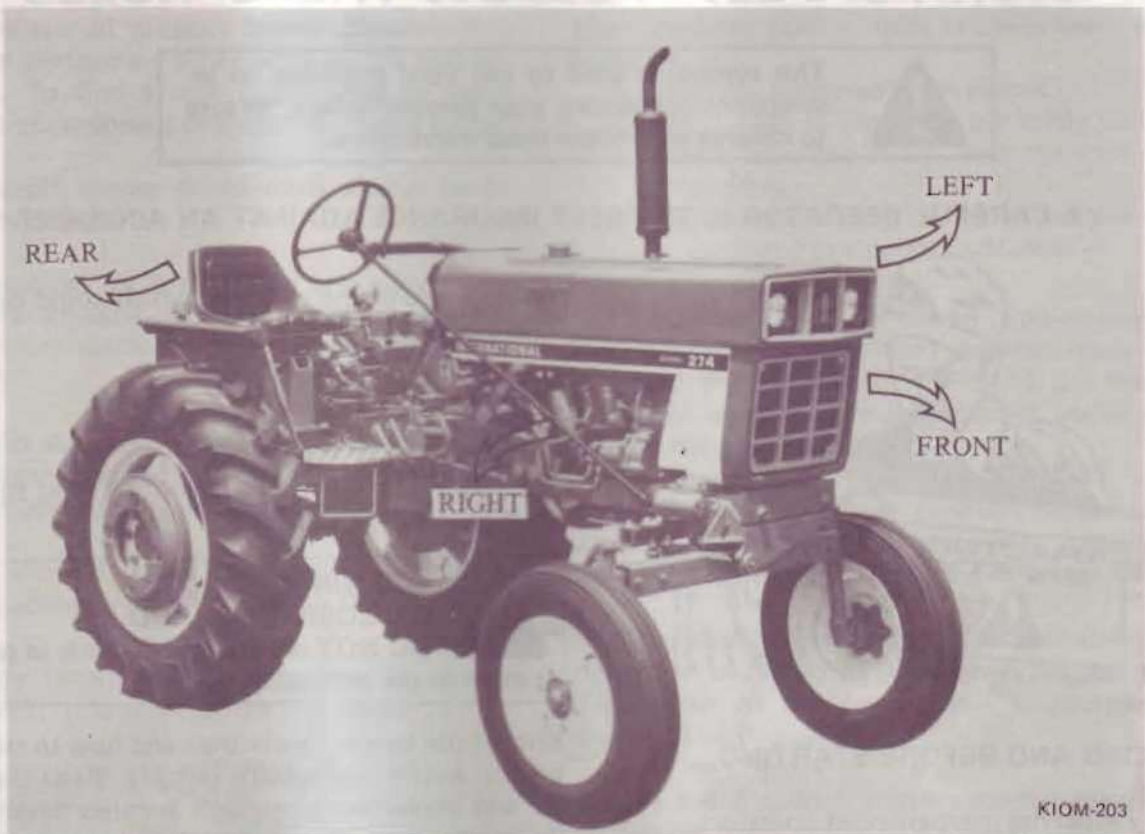

International 274 Tractor showing terms of location



CAUTION! For your protection in the event of accidental upset, International Harvester Company recommends the use of a protective frame.

Assembled in this manual are operation, lubrication and maintenance instructions for International 274 Tractors. This material has been prepared in detail in the hope that it will help you to better understand the correct care, efficient and safe operation of the tractor.

Throughout this manual the use of the terms LEFT, RIGHT, FRONT, and REAR must be understood when following instructions to avoid confusion. LEFT and RIGHT indicate the left and right sides of the tractor when facing forward in the driver's seat. FRONT indicates the radiator end of the tractor; REAR indicates the hitch end.



CAUTION

Read the Operator's Manual.
Learn to operate this machine SAFELY.
Be alert Observe All Safety Practices.
Machines can be hazardous in the hands of an
UNFAMILIAR, UNTRAINED or COMPLACENT
operator.
Don't risk INJURY or DEATH.

WORK SAFELY—FOLLOW THESE RULES



This symbol is used to call your attention to instructions concerning your personal safety. Be sure to observe and follow these instructions.

A CAREFUL OPERATOR IS THE BEST INSURANCE AGAINST AN ACCIDENT



SERVICING AND BEFORE STARTING

Carefully supervise inexperienced operators.

Be sure that the fuel tank cap is fully tightened against the stop before starting the engine.

Check coolant and engine oil levels, and perform any other necessary services, before starting the engine.

Turn the radiator cap slowly counterclockwise to the pressure release point to allow the pressure or any steam to escape; then press down on the cap and continue to turn until the cap is free to be removed.

Check brakes and clutch pedal for correct adjustments.

Reduce tipping hazards by spreading wheels as far as your work program permits.

Be sure muffler and exhaust pipe are in place so exhaust gases are discharged above the operator.

Always keep the operators compartment clean. Keep dirt, trash, and grease from the pedals, steps, mounting handles, steering wheel, and controls.

Always carry a "Charged" fire extinguisher and a first aid kit.

Avoid loose-fitting clothing, which could catch on moving parts.

STARTING

Starting Fluid (Ether) must not be used to aid in starting the engine.



WARNING!
EXPLOSION HAZARD
DO NOT use starting aid such as gasoline or ether in the air intake.

Know how to use the controls and how to stop the tractor and/or implements quickly. Read the tractor and implement operator's manuals thoroughly. Be in the operators seat and fasten seat belt if supplied with a ROPS frame.

Set the parking brake lever and place the transmission gear shift lever in the neutral position before starting the engine.

Be sure the power take-off rod is in the "OFF" disengaged position before starting the engine. Make sure that the helpers or observers stand clear of the equipment.

Never operate vehicle in an enclosed area.

Make sure the area is well ventilated.

DURING OPERATION

Carefully supervise inexperienced operators. Hydraulic fluid escaping under pressure can have enough force to penetrate the skin. Hydraulic fluid may also infect a minor cut or opening in the skin. **If injured by escaping fluid, see a doctor at once.** Serious infection or reaction can result if medical

treatment is not given immediately. Make sure all connections are tight and that hoses and lines are in good condition before applying pressure to the

WORK SAFELY – FOLLOW THESE RULES

system. Relieve all pressure before disconnecting the lines or performing other work on the hydraulic system. To find a leak under pressure use a small piece of cardboard or wood. Never use hands.

Power take-off master shield must always be in place on the tractor.

Stop the engine, set the parking brake lever and place the transmission gear shift lever in the neutral position before dismounting from the tractor for any reason.

Always keep shields in place. Disengage PTO, shut off the engine, and remove the key before adjusting or unclogging power driven machinery.

No riders allowed. Make certain that everyone is clear of machinery before starting the engine or operation.

IH strongly recommends a roll over protective frame (ROPS). It is available for this tractor.



CAUTION! Never allow unauthorized riders.

MA-16868

Keep others, especially children, from riding on steps, fenders, or drawbar, and away from tractor equipment.

Use the drawbar when hitching to a heavy load.

Pull only from drawbar; never hitch to axle housing.

Always keep the tractor in gear when going down hills. A towed vehicle having a gross weight greater than the weight of the towing tractor must be equipped with its own brakes.

Stay alert for holes, rocks, tree stumps and other hazards in terrain which could cause an upset or loss of control which could result in injury.

Use care when pulling loads or using heavy equipment:

- A. Use only approved hitch points.
- B. Limit loads to those you can safely control.
- C. Don't turn too sharp, and use care when backing.
- D. Use counterweight or wheel weights when suggested in Operator's Manual

With trail-behind PTO driven implements the hitching point on the fixed drawbar must be in line with the PTO shaft. If it is not, the driveline may pull apart or create excessive angles when turning the tractor.

Check overhead clearance carefully before driving under power lines, guy wires, bridges, low hanging tree branches, entering or leaving buildings, etc.

One standard wheel weight must remain on the right rear wheel to help maintain proper weight distribution of the tractor and to decrease the chance of an overturn.

Always avoid sudden starts, excessive speed, and sudden stops.

To assure the protection provided by design, the protective frame must not be altered by welding, cutting, drilling, or in any other manner.

TRANSPORTING

Use warning devices (i.e. flags, S.M.V. emblem, lights, etc.) which are approved for use by your local government agencies, when moving equipment on public roads. Keep these devices clean and in good working condition.

Before moving on public roads, or from field to field, lock the brake pedals together for simultaneous operation.

Reduce speed when traveling on rough roads, sharp turns, and down steep hills.

For your safety, avoid heavily-traveled roads when moving equipment.

Be sure hitches and/or drawbars are properly stabilized before towing equipment. Be courteous, have consideration for other traffic using the road.

WORK SAFELY – FOLLOW THESE RULES

When transporting on the highway, use a safety chain with a 10,500 pound (4767 kg) gross load capacity be used with tractor and trailed implement.

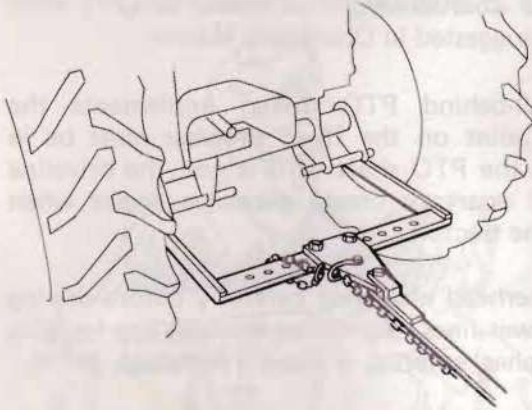

Install clevis as shown leaving some chain slack at the tractor drawbar plate.

After attaching the hitch safety chain, make a trial run by driving the tractor to the right and to the left for a short distance to check the safety chain adjustment. If necessary, readjust to eliminate tight or loose chain.

BEFORE DISMOUNTING

Wait for the tractor to come to a complete stop, shut off the engine, set the parking brake lever, and place the transmission gear shift lever in the neutral position, and stop power take-off if engaged.

Lower implements to the ground before leaving the tractor.

Always remove the key when leaving the tractor to avoid unauthorized operation.

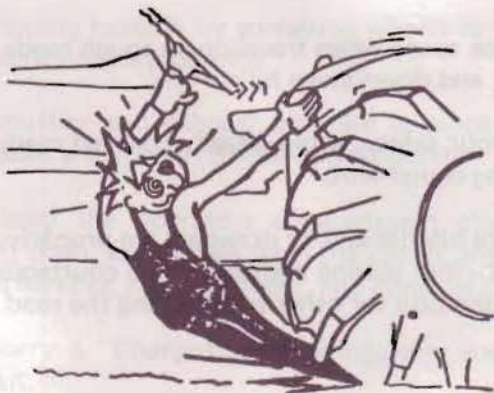

CAUTION! Always engage park, lower equipment and shut-off engine before dismounting. Never start engine from ground.

MA-16882

AFTER AN UPSET

No attempt should be made to straighten, weld, or otherwise repair the protective frame for further service. It must be replaced in its entirety.

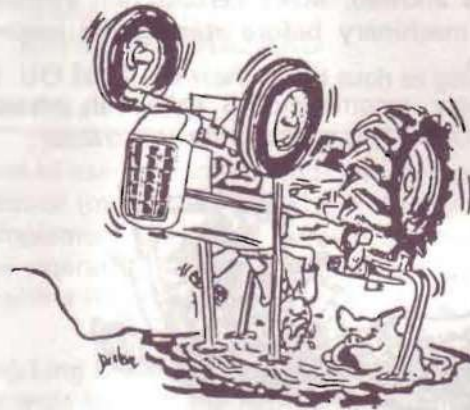

CAUTION! Avoid tipping hazards. Spread wheels as wide as operation permits and do not drive close to ditches. **USE SEAT BELTS** with ROPS and safety enclosures.

MA-16858

NOTE: Do not operate the tractor or run the engine until a thorough inspection has been made to determine that all components, controls, etc. are operating correctly. The tractor must be inspected for other damage, preferably, by your International Harvester dealer, and all necessary corrections made.

Misuse or modification of this machine can cause mechanical breakdown, property damage, injury or death. Always use proper safety precautions. Tell your workers how to work safely.

INSTRUMENTS AND CONTROLS

Before attempting to start or operate the tractor, be sure to review all the instructions for the new tractor and thoroughly familiarize yourself with the instruments and controls.

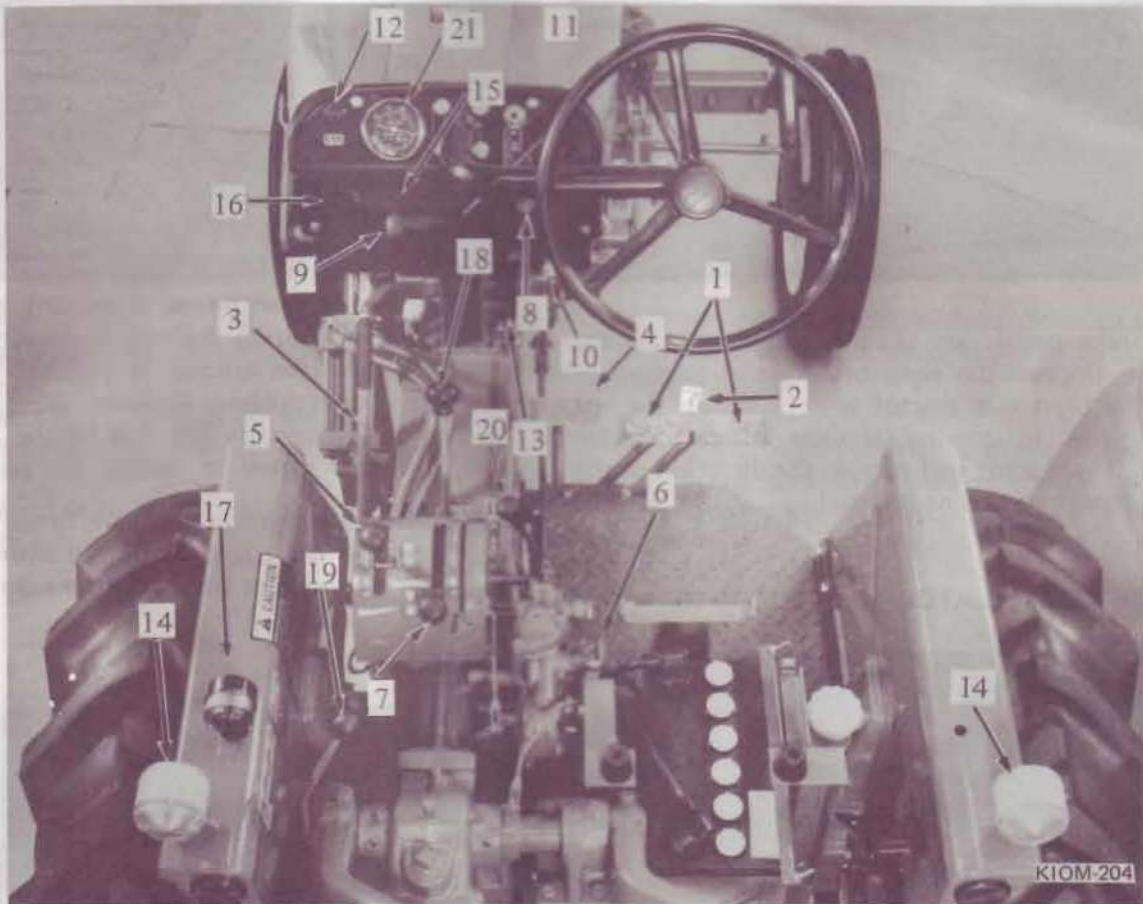

- | | |
|--|---|
| 1 – Brake pedal | 13 – Fuse block |
| 2 – Brake pedal latch | 14 – Flashing warning light |
| 3 – Park brake lever | 15 – Flashing warning light switch |
| 4 – Clutch pedal | 16 – Head and taillight switch |
| 5 – Auxiliary hydraulic control lever | 17 – Taillight |
| 6 – Drop control knob | 18 – Gear shift lever |
| 7 – Three-point hitch position control lever | 19 – Power take-off lever |
| 8 – Starting key switch | 20 – Transmission range lever |
| 9 – Engine speed control lever | 21 – Instrument cluster
(Tachometer, speedometer,
hour meter, water temperature
telltale, oil pressure
telltale and charge indicator
telltale) |
| 10 – Fuel shut-off knob | |
| 11 – Glow plug signal | |
| 12 – Low fuel indicator lamp | |

INSTRUMENTS AND CONTROLS

BRAKE PEDALS

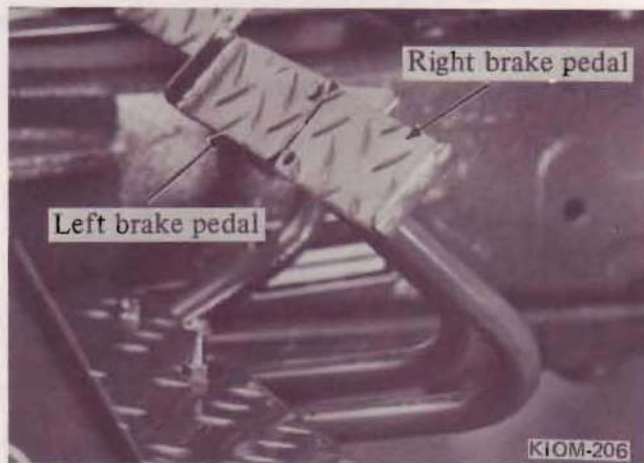

The brake pedals are used to aid in turning the tractor. Depress the right brake pedal to slow or stop the right rear tractor wheel, depress the left brake pedal to slow or stop the left rear tractor wheel. The tractor will turn in the direction of the wheel that is slowed or stopped.

BRAKE PEDAL LATCH



The brake pedal latch is located in the top edge of the left brake pedal and is used to latch the two pedals together to provide simultaneous braking to both rear wheels when the brake pedals are depressed. To latch the pedals together, pivot the latch and engage it in the slot in the right pedal. For individual brake action, pivot the latch into the storage slot in the left brake pedal.

PARK BRAKE LEVER



The park brake must be on to prevent movement of the tractor during stationary power take-off work or when the tractor is parked. The park brake is on when the lever is pulled up. Depress the button on the end of the lever and move the lever down to release the park brake.

NOTE: The transmission and park brake lock may be damaged if the tractor is moved with the park brake on. Do not put the park brake on with the tractor in motion.

CLUTCH PEDAL



The clutch must be released when stopping the tractor, turning on the power take-off, operating the gearshift lever, or operating the transmission range lever. To release the clutch, press the pedal all the way down. Let the clutch pedal up slowly to start the tractor in motion.

INSTRUMENTS AND CONTROLS

AUXILIARY HYDRAULIC CONTROL LEVER



This lever is used to raise and lower the mid-mounted cultivator.

To raise, move the lever to the rear and hold it. To lower, move the lever forward and hold it.

The lever returns to the neutral position automatically when it is released.

THREE POINT HITCH POSITION CONTROL LEVER

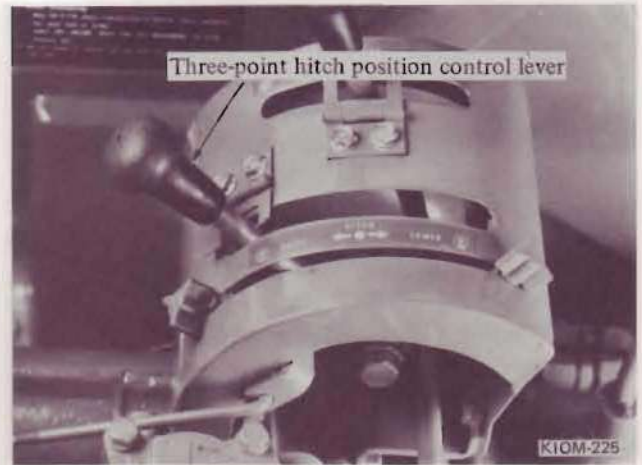

Move the position control lever forward to lower the three-point hitch. Move the lever to the rear to raise the hitch.

A latch is provided to lock the lever in raised position. Make sure this latch is engaged whenever hitch is to be left in raised position while operating tractor.

DROP CONTROL KNOB



Turn the knob clockwise to slow the rate at which the three-point hitch lowers. Turn the knob counterclockwise to increase the lowering rate.

STARTING KEY SWITCH

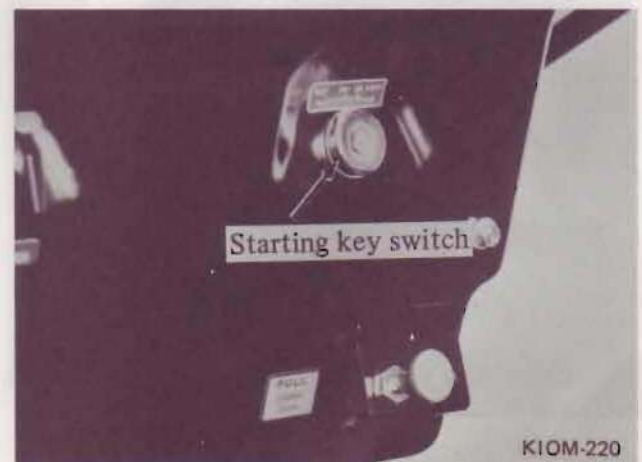

The starting switch key can be removed with the switch in the "OFF" position. Always insert the key in the position shown. The key must be in the position "ON" while operating the engine.

INSTRUMENTS AND CONTROLS

ENGINE SPEED CONTROL LEVER

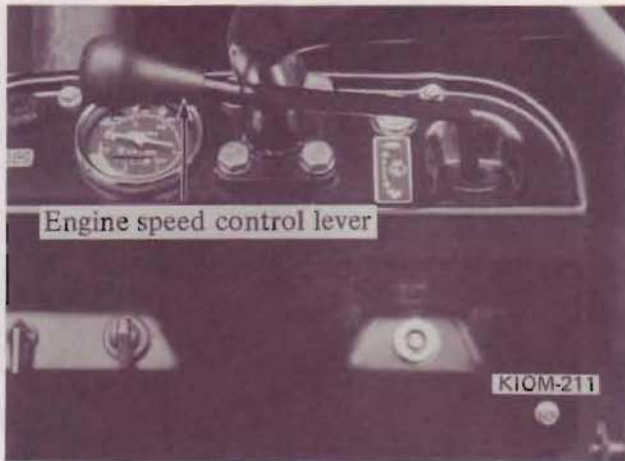

Move the knob end of the engine speed control lever to the rear to increase engine speed. Move the knob end of the engine speed control lever forward to decrease engine speed.

GLOW PLUG SIGNAL



This signal indicates the correct functioning of the glowplug circuit. When the signal reaches maximum brilliance, the glowplugs have reached the correct temperature for engine starting.

To energise the glowplugs, turn the key counter-clockwise from the "OFF" position and hold it.

FUEL SHUT OFF KNOB



The fuel shut off knob is used to stop the engine. To stop the engine, pull the knob out fully. See "OPERATING THE TRACTOR".

LOW FUEL INDICATOR LAMP



The low fuel indicator lamp will light to indicate that 1½ gallons (5.5 liter) of fuel remains in the fuel tank. See "STARTING THE TRACTOR" for check to determine if the tellite is functional.

INSTRUMENTS AND CONTROLS

FUSE BLOCK

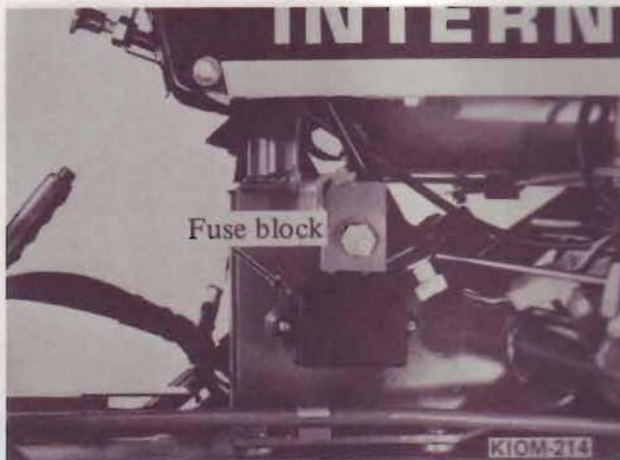

Three fuse elements located under the fuse holder cover system. See "ELECTRICAL SYSTEM" for replacement instructions.

FLASHING WARNING LIGHT SWITCH

Flashing warning light can be flashed by turning the switch clockwise.

It is independent of key switch.

This light is for use on public highway to warn drivers of other vehicles that they are approaching a slow moving vehicle.



See "DRIVING ON PUBLIC ROAD" in "OPERATING THE TRACTOR".

HEAD AND TAILLIGHT SWITCH



The switch has four positions: "OFF" position; "TAIL" position for the instrument panel and red taillight; "LOW" position for panel light, red taillight and dim headlights; "HIGH" position for red taillight, panel light and bright headlights.

NOTE: The switch works independently of the key switch.

TAILLIGHT

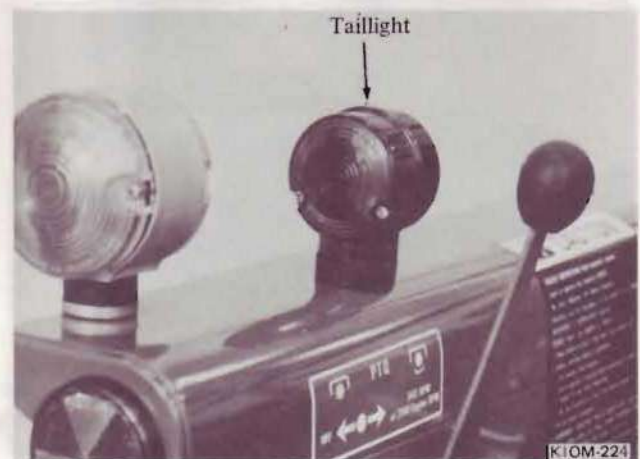

The taillight is turned on by the head and taillight switch. See "HEAD AND TAILLIGHT SWITCH".

INSTRUMENTS AND CONTROLS

GEARSHIFT LEVER

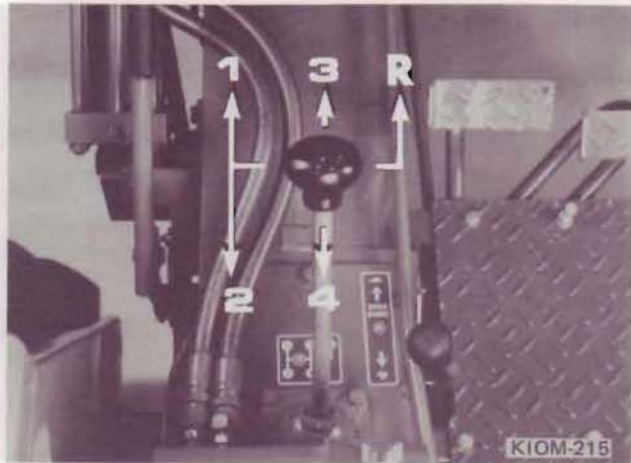

This lever is used to shift the transmission gears into reverse or any of the four forward speed ranges.

POWER TAKE-OFF LEVER

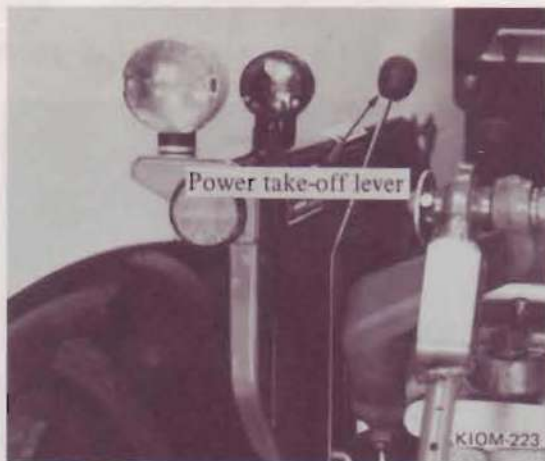

Push this lever forward for power take-off operation. Pull the lever back against the lock tab on the locking plate to turn-off the power take-off.

The lever is locked in "OFF" position to avoid inadvertent engagement of PTO.

See "POWER TAKE-OFF" under "ADJUSTING AND OPERATING".

TRANSMISSION RANGE LEVER



Move the transmission range lever forward to place the transmission in "LOW" range. Move the lever to the rear to place the transmission in "HIGH" range. The center position places the transmission in "NEUTRAL".

INSTRUMENTS AND CONTROLS

INSTRUMENT CLUSTER

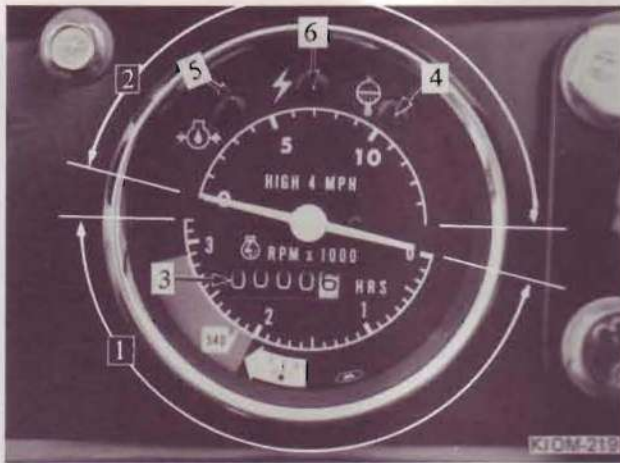

- 1 – Tachometer
- 2 – Speedmeter
- 3 – Hour meter
- 4 – Water temperature tellite
- 5 – Oil pressure tellite
- 6 – Charge indicator tellite



TACHOMETER

The tachometer indicates engine speed in revolutions per minute. (r.p.m.)

SPEEDMETER

The speedmeter indicates ground speed in miles per hour in fourth gear (High range).

HOUR METER

The hour meter indicates hours of engine operation up to 9999.9 hours. The hour meter is accurate at 1800 engine rpm.



WATER TEMPERATURE TELLITE

The water temperature tellite indicates high engine coolant temperature.

If the light comes on, remove the load and allow the engine to run at high idle until the light goes out. If the light does not go out within one minute, top the engine and determine the cause.

See "STARTING THE TRACTOR" for check to determine if the tellite is functional.



OIL PRESSURE TELLITE

The oil pressure tellite indicates low engine oil pressure. If it lights during engine operation, stop the engine immediately and determine the cause.



CHARGE INDICATOR TELLITE

The charge indicator tellite indicates the battery is being discharged. If the light comes on during operation, determine and correct the cause to avoid complete discharge of the battery and possible damage to other elements of the electrical system. See your International Harvester dealer.

HOOD OPEN LEVER

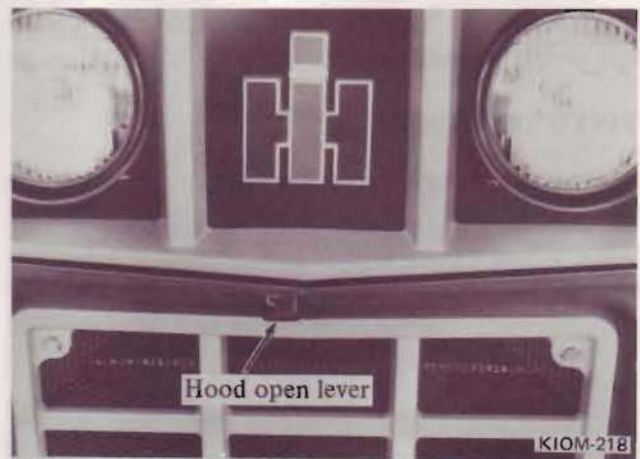

The lever is used to release the latch of front hood. Front hood can be opened by hand after releasing the latch. See "PREVENTIVE MAINTENANCE".

OPTIONAL INSTRUMENTS AND CONTROLS

DIFFERENTIAL LOCK PEDAL



Push down on the differential lock pedal with the right heel to lock the rear wheels together to prevent one wheel from spinning on a wet or slippery surface. Remove the heel from the pedal to release the differential lock.

Refer to "DIFFERENTIAL LOCK" under "OPERATING THE TRACTOR".

NOTE: Always release the differential lock before making a turn.

FIXED DRAWBAR

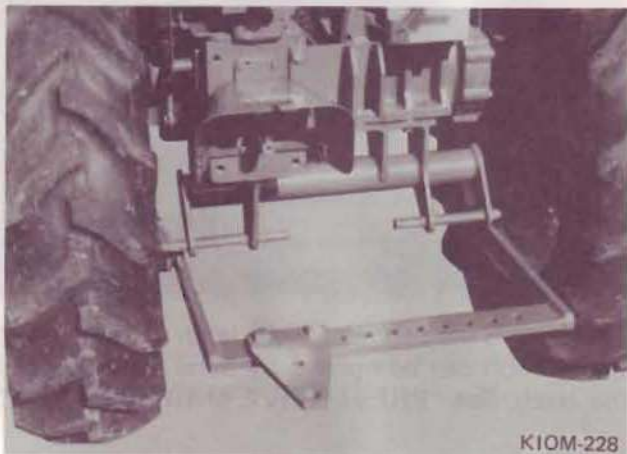

See "HITCHING TRAILING EQUIPMENT TO THE TRACTOR".
REAR WORK LAMP



The rear work lamp is turned on by the switch on the work lamp.

It is independent of the ignition switch.

See "OPERATING THE TRACTOR".



CAUTION! Do not turn on the rear work lamp while traveling on public road.

ENGINE COOLANT HEATER

The block type engine coolant heater is available as optional equipment.

Refer to "COLD WEATHER PRECAUTION".

BEFORE OPERATING THE TRACTOR

CAREFULLY READ "WORK SAFETY - FOLLOW THESE RULES"

LUBRICATION

Check the oil levels of the engine crankcase, transmission, and all gear cases to see that they are filled to the correct levels with oil of the proper viscosity for the prevailing temperature. Refer to "LUBRICATION GUIDE".

NOTE: DO NOT operate the tractor with shipaway oil in temperatures above 90°F (32°C) or below 0°F (-18°C). See "LUBRICATION GUIDE".

Lubricate the entire tractor as described in the "LUBRICATION GUIDE".

AIR CLEANING SYSTEM

Check all rubber hoses for cracks and be sure all hose connections are tight. See "AIR CLEANING SYSTEM".

TIRES

Check the air pressure in the pneumatic tires and inflate or deflate the tires to the air pressure specified in the tables under "TIRES". Tire treads should be cleared of rocks or other foreign objects that could be thrown from the tire causing personal injury or damage to the tire.

ENGINE COOLING SYSTEM

Be sure the coolant is at the correct level. See "COOLING SYSTEM".

NOTE: Tractors shipped to destinations in the United States and Canada have the cooling system filled with antifreeze solution. Be sure the antifreeze is adequate for prevailing cold temperature conditions. See "COLD WEATHER PRECAUTIONS".

Never start or operate the engine without water or antifreeze solution in the cooling system.

FUEL

Grade 2-D diesel fuel conforming to ASTM D-975 specification must be used for proper operation of diesel tractor. Grade 1-D diesel fuel may be used at temperatures below +10°F (-12.2°C) or for operations entailing considerable idling. Use only winter grade fuel for case of starting. Winter grade diesel fuel must have a cloud point of at least +10°F (-12.2°C) below the lowest anticipated temperature to avoid plugging of the fuel circulation system, especially the fuel filters.

Use clean fuel and keep it clean. Store fuel in tanks equipped with hose and nozzle to prevent contamination of the fuel. The use of funnels, cans, and drums is not recommended because they are difficult to keep clean.

Allow space for fuel expansion when adding fuel to the tank. A tank filled to capacity may overflow if exposed to a rise in temperature or direct sunlight.



CAUTION! Do not add gasoline or alcohol to diesel fuel. This creates a vapor which is extremely explosive.

BEFORE OPERATING THE TRACTOR

ADJUSTING THE SEAT



- 1.- Seat pivot rod
- 2.- Q.A. pin

To adjust the seat remove the Q.A. pin and seat pivot rod. Move the seat to the desired position then install seat pivot and Q.A. pin.

ENGINE BREAK-IN PROCEDURE

Your new tractor is delivered with proper adjustment and careful inspection. However, do not operate the tractor with heavy loads during the first 20 working hours. Overloading may result in premature wear.

Warm up the tractor for at least 5 minutes. Especially in cold climates, a warm-up period is required until engine oil reaches operating temperature.

Never operate a new engine immediately under full load. Brake it in carefully as shown in the table below.

Period	Engine Speed Control Lever Position	Load
1st Hour	1700 ~ 2000 r.p.m.	Light
2nd Through 20th Hour	Fully Advanced	Moderate

During first 50 hours of operation with shipaway oil, avoid prolonged periods of engine idling.

OPERATING THE TRACTOR

STARTING THE TRACTOR

1. Open the fuel shut off valve. See "FUEL SYSTEM".
2. Mount the tractor and fasten seat belt if the tractor has Roll Over Protective Structure.
3. Be sure the park brake is on. Press the clutch all the way down. Place the gear shift lever in the neutral position and turn off the power take off. See "INSTRUMENT AND CONTROL".
4. Push in the fuel shut off lever fully.
5. Set the fuel control lever at high idle position.
6. Insert the start switch key and turn it clockwise to the "ON" position. The oil pressure tellite, charge indicator tellite, water temperature tellite and low fuel indicator lamp will light, informing you that it is operational. If the lights do not appear, turn off the switch, remove the key and have the cause determined and corrected.
7. Turn the key fully counterclockwise and hold to energize the glowplugs for 15 to 20 seconds.
8. When the glowplugs indicator reaches the brilliance, turn the key fully clockwise to the "START" position.

NOTE: If the engine is warm the glowplugs do not need to be energized.

NOTE: The engine can only be started when the safety starting switch is activated by depressing the clutch pedal all the way down. Do not operate the starter for more than 30 seconds at any one time. If the engine does not start within this time, turn the key "OFF", wait a few minutes, then try again.



CAUTION! Starting fluid (ether or gasoline) must not be used when glowplugs are used to aid in starting the engine.

AFTER THE ENGINE STARTS

NOTE: Never operate the starter while the engine is running.

1. As soon as the engine starts, push the engine speed control lever to moderate speed position to warm up the engine.

Immediately after the engine starts, the oil pressure tellite should go out. If the light stays on, turn off the engine immediately, remove the key, determine and correct the cause. Operation without oil pressure will cause severe damage to the engine.



CAUTION! Do not run the engine in confined areas such as storage buildings any longer than is necessary for the immediate moving of the tractor out of or into the area. Exhaust gases are toxic. Opening doors and windows may not provide adequate ventilation.

2. Release the park brake before moving the tractor to avoid possible damage to the brake and transmission. See "INSTRUMENTS AND CONTROLS".
3. Turn front wheels in desired direction.
4. Adjust throttle to desired engine speed. The throttle setting should be 1/3 or less of the full speed setting when moving the tractor in a confined area such as a garage or storage building.
5. Select the desired gear range for moving the tractor. See "DRIVING THE TRACTOR".



CAUTION! Check overhead clearance carefully before entering or leaving buildings, driving under power lines, guy wires, bridges, low hanging tree branches, or other situations where the operator may be struck or pulled from the tractor resulting in serious injury.

OPERATING THE TRACTOR

DRIVING THE TRACTOR

To Shift Gears

NOTE: Do not shift gears while the tractor is in motion.

Depress the clutch pedal.

Place the gearshift lever and transmission range lever in the desired positions.

Slowly release the clutch pedal.

For ground speed, see "SPECIFICATIONS".

NOTE: Driving speed depends on the load applied.



CAUTION! Before backing the tractor, always look for obstacles or bystanders in the area where the tractor will move.

NOTE: Do not "ride" the clutch or brake pedals by resting the feet on the pedals while driving the tractor because this will result in excessive wear.



CAUTION! Use the brakes as turning brakes only at low speeds to maintain control of the tractor.



CAUTION! Pedals must be latched together when operating the tractor in third or fourth gear, in high range.

When moving on public roads, or from field to field, latch brake pedals together for simultaneous operation when making a stop to reduce the possibility of loss of control and upset or collision.

DRIVING ON SLOPES

Before operating the tractor on any slope, walk the slope to look for possible hazards such as rocks, mounds, ruts, stumps or other surface irregularities which could cause an upset.

Drive up or down the face of a slope.

Back the tractor with front or mid-mounted implements up the steepest portion of each slope you intend to work. If the tractor can not negotiate the slope in reverse, the slope is too steep to be worked.



CAUTION! This Off-Set, Hi-Clear Tractor is more susceptible to tipping to the left than conventional tractor.

Use first gear in low range when driving on a steep slope. The tractor must always be in gear to take advantage of engine braking during operation on a slope.

Avoid turns when driving on a slope. If a turn must be made, turn down the slope. Turning up a slope greatly increases the chance of a roll over.

Avoid stopping when driving up a slope. If it is necessary to stop while driving up a slope, start up smoothly and carefully to reduce the possibility of flipping the tractor over backward.

TOWING THE TRACTOR

When towing is necessary, use a tow rope, chain, or cable and have an operator steer the tractor and operate the brakes.

When towing a tractor out of a stuck condition, the power of both tractors should be used. A steady, even pull must be kept on the tractor all the time.

Before towing the tractor, to transport it from one place to another, check the local laws. It is not recommended that a tractor be towed for great distances because of safety hazards, but when it becomes necessary the following procedure should be followed.

OPERATING THE TRACTOR

TOWING THE TRACTOR - Continued

1. Make sure the parking brake is in the released position.
2. A driver must be in the tractor seat to steer the tractor and apply the brakes.
3. Do not tow over 9.3 miles per hour (15 kilometers per hour).

DRIVING ON PUBLIC ROAD

When travelling on public road, use the SMV (Slow Moving Vehicle) emblem, flashing warning lights and other warning devices which are approved for use by your local government agencies.

Keep these devices clean and in good working condition.



CAUTION! Do not use the rear work lamp while travelling on public road. The light may confuse and blind the motorist and cause an accident.

Be sure hitches and/or drawbars are properly stabilized before towing equipment to reduce possibility of loss of control and upset or collision.

Shut off power to any attachment when transporting or not in use.

For your safety avoid heavily-traveled roads when moving equipment, if at all possible.

When moving on public roads, or from field to field, lock brake pedals together for simultaneous operation when making a stop to reduce the possibility of loss of control and upset or collision.

Reduce speed when traveling on rough roads to avoid loss of control and upset or collision.

Be courteous, have consideration for other traffic using the road. Drive defensively.

STOPPING THE TRACTOR

1. Push engine speed control lever all the way forward.
2. Depress the clutch pedal.
3. Depress the brake pedal to stop and hold the tractor.

NOTE: The brakes are not intended for use in parking, or other stationary jobs since normal fluid seepage tends to release the brake. The park brake is provided for this purpose.

4. Place the PTO control in the "off" position.
5. Place the gearshift lever in the neutral position.
6. Slowly release the clutch pedal.
7. Put the park brake on.

NOTE: Do not rely on having tractor in gear. It may cause the possibility of coasting down a slope.

8. Lower equipment to ground before leaving tractor to avoid the possibility of the equipment dropping and causing injury.

9. Turn off lights.
10. Pull the fuel shut off lever
11. Turn the key to the "OFF" position.

NOTE: If the engine has just operated under heavy load, allow the engine to idle at 1500 r.p.m. until temperature is reduced, then push the engine speed control lever all the way forward and stop the engine.

OPERATING THE TRACTOR

STOPPING THE TRACTOR - Continued

12. Remove the key.
13. Dismount from the tractor only after all rotating implements have stopped.

NOTE: It is advisable to close the fuel shut-off valve if the engine is to be stopped for any length of time. See "FUEL SHUT VALVE" under "PREVENTIVE MAINTENANCE".

DIFFERENTIAL LOCK (OPTIONAL)

The differential lock equalizes drive wheel slip when one wheel is operating under poorer traction conditions than the other. Continual engagement of the differential lock is not harmful to the wearing parts and may improve performance of the tractor even when excessively unequal slip is not apparent. However, the differential lock must be disengaged before attempting turns.

The pedal may be depressed to engage the differential lock under wheel slip or when the tractor is still in motion. If one wheel is spinning too rapidly for the differential lock to engage, a clicking noise will be heard. If this continues for more than a few seconds, depress the engine clutch pedal momentarily and the differential lock will come into operation immediately.

If the differential lock does not disengage when the foot is taken off the differential lock pedal as evidenced by the pedal remaining in the depressed position, quick pressure on one of the brake pedals or the clutch pedal will release the differential lock.

REAR WORK LAMP (OPTIONAL)



The rear work lamp is turned on by the switch on the lamp.

The lamp should be used only when the tractor is operated in the field.



CAUTION! Do not use the rear work lamp while traveling on public road.

TRANSPORTING

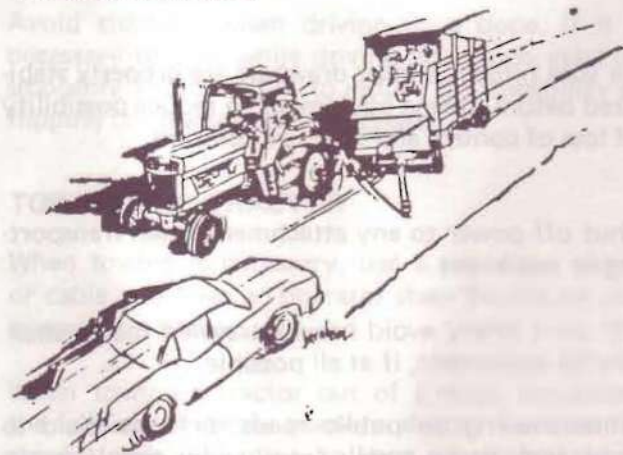

CAUTION! When road transporting, lock brakes together, use lighting and making devices consistent with local law enforcement agencies. Use **SAFETY CHAINS** on towed equipment.

MA-16857

POWER TAKE-OFF

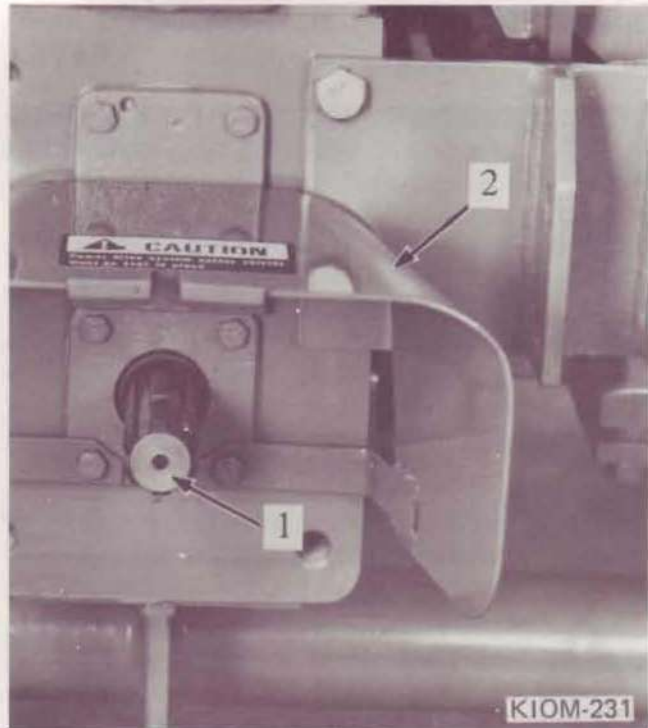

1 – Power take-off output shaft
2 – Power take-off shield

GENERAL

The power take-off is powered by the same engine clutch as the tractor. Be sure to disengage the engine clutch before moving the power take-off lever.

The power take-off on this tractor has the 540 r.p.m. shaft setting at 2160 engine r.p.m. The power take-off shaft conforms to American Society of Agricultural Engineerings (A.S.A.E.) and Society of Automotive Engineerings (S.A.E.) standards for 540 r.p.m. drawbar pulled power take-off equipment. Engine speed can be changed as PTO load varies in order to maintain a 540 rpm PTO speed. For PTO operation do not exceed 2500 engine rpm.

OPERATING THE POWER TAKE-OFF



CAUTION! The power take-off lever must always be in "OFF" position and locked with the latch when the power take-off is not used.

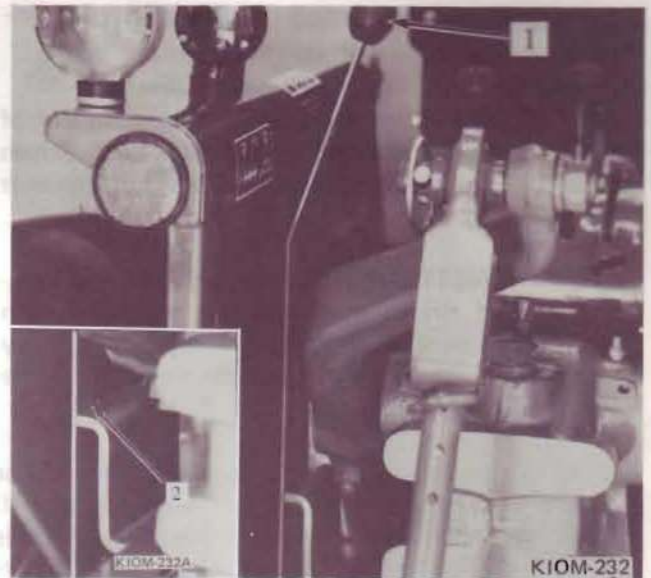

1 – Power take-off lever
2 – Latch in "OFF" position

Illustration shows the power take-off disengaged position.

1. The transmission gearshift lever must be in neutral position.
2. Move the engine speed control lever to the low idle speed position.
3. Depress the clutch pedal to release the engine clutch.
4. Move the power take-off lever forward to engage the power take-off.
5. Select the desired transmission speed.

For stationary power take-off equipment leave the transmission in neutral and engage the park brake.

6. Slowly release the clutch.
7. Advance the speed control to desired engine speed (rated PTO speed) slowly to make sure rotating equipment is running properly before engaging load.

POWER TAKE-OFF

OPERATING THE POWER TAKE-OFF - Continued



CAUTION! Be sure everyone is clear of the tractor and power take-off driven equipment before starting the power take-off.



CAUTION! When operating power take-off driven machines not equipped with an overrunning clutch (such as a rotary brush cutter), the following precautions should be taken:

Slowdown when approaching trees, fences, or ditches. Flywheel effect of the driven machine will drive the tractor forward after the engine clutch is disengaged. To stop the forward travel more quickly, retard the engine speed control lever, disengage the engine clutch, move power take-off lever to "OFF", move the gear shift lever to the neutral position, and apply tractor brakes.



CAUTION! Be sure to stop the power take-off before dismounting from the tractor.



CAUTION! When operating the power take-off, be sure that the master shield covering the power take-off exposed shaft is always in place. When the power take-off is not in use, always keep it covered with the power take-off shaft guard.



CAUTION! Do not exceed 2500 engine r.p.m. for PTO operation. Speeds in excess may damage the implement and may cause personal injury.

Refer to "POWER TAKE-OFF SHAFT SPEED" under "SPECIFICATION" section of Manual.



CAUTION! Good judgement must be exercised when selecting implements to be powered by the tractor PTO. The tractor's PTO center line is offset to the left of the tractor center line. The offset may create PTO working angles that increase implement wear. Refer to the implements' operator's manual or to a qualified IH dealer to determine safe PTO angles.

HYDRAULIC LIFT AND HITCH SYSTEMS

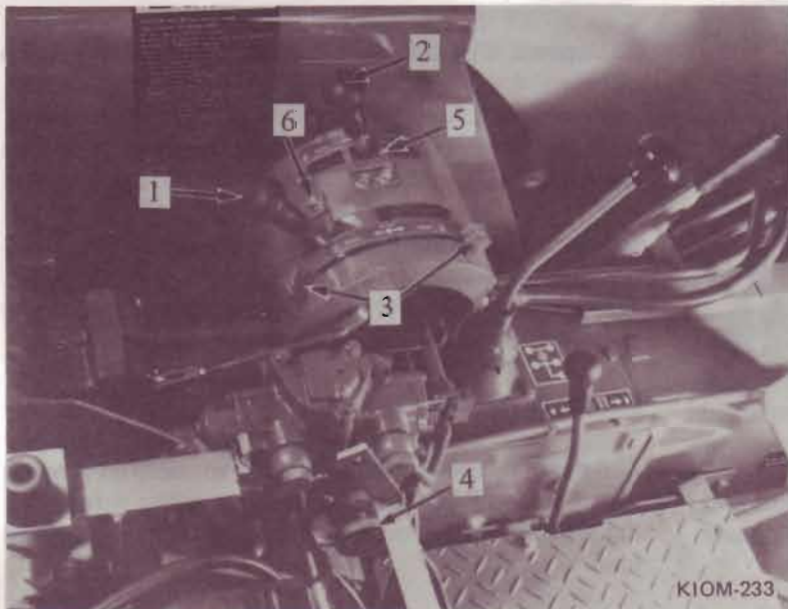

- 1 — Three point hitch position control lever
- 2 — Auxiliary hydraulic control lever
- 3 — Adjustable stoppers
- 4 — Drop control knob for three point hitch
- 5 — Neutral latch
- 6 — Raised position latch

THREE POINT HITCH POSITION CONTROL LEVER

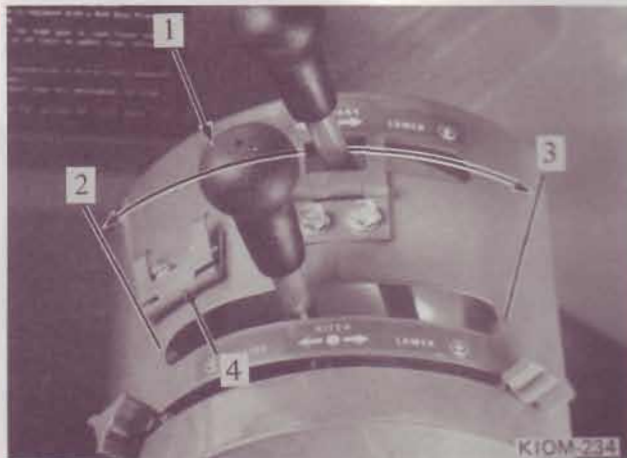

- 1 – Three point hitch position control lever
- 2 – Maximum raised position
- 3 – Maximum lowered position
- 4 – Lever lock latch

The lever is used to raise or lower the equipment mounted to the three point hitch.

The position of this lever indicates the relative position of the equipment.

When the lever is placed at the forward end, the hitch will drop to its lowest position.

When the lever is placed at the rear position, the hitch is as high as it will go. Make sure the lever is latched when left in this position while operating tractor.



CAUTION! When transporting the tractor on the road with the equipment mounted on the three point hitch, always lock the control lever with the latch at the highest position.

NOTE: When using 3-pt. hitch, check for interference with fixed drawbar. If fixed drawbar is installed with 3-pt. hitch, be sure the 3-pt. hitch lower links are above the fixed drawbar.



CAUTION! Never park equipment in the raised position. Moving the control lever will lower the equipment even though the engine is not running. If it is necessary to service the equipment in the raised position, use jackstands to safely block the equipment in place.

AUXILIARY HYDRAULIC CONTROL LEVER

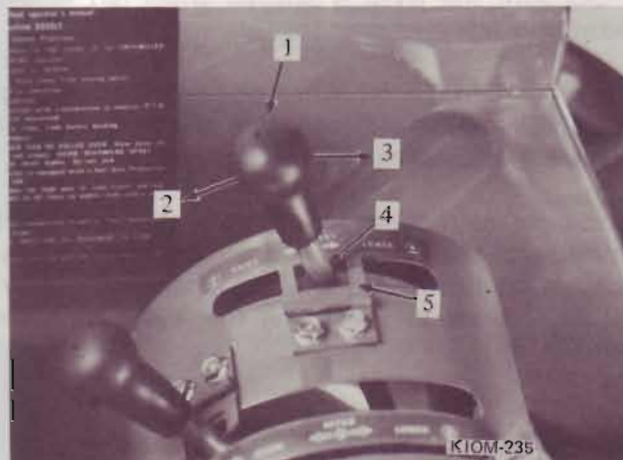

- 1 – Raise position
- 2 – Lower position
- 3 – Neutral position
- 4 – Neutral latch

The lever is used to raise or the mid-mounted cultivator.

The double acting auxiliary control valve is provided on the three point hitch position control valve and operated by the lever.

The auxiliary control valve actuates the auxiliary hydraulic cylinder and raises or lowers the mid-mounted cultivator.

An adjustable stop collar on the cylinder rod will automatically stop the equipment at a preset depth.

When the lever is moved to the rear, the auxiliary hydraulic cylinder extends to raise the cultivator.

HYDRAULIC LIFT AND HITCH SYSTEMS

AUXILIARY HYDRAULIC CONTROL LEVER - Continued

When the lever is moved forward, the cylinder retracts to lower the equipment.

The lever returns to the neutral position automatically when it is released.

Make sure the lever is latched when left in this position while operating tractor.



CAUTION! When the auxiliary control lever is not used, lock the lever with the latch at the neutral position.

Complete instructions for operating the valve levers and use of the cylinder are included in the operator's manual furnished with the equipment. General instructions for operating the levers are given here.

ADJUSTABLE STOPPERS

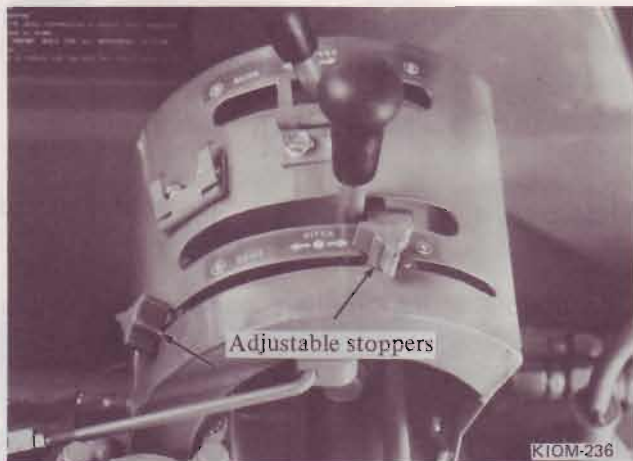

Adjustable stoppers are provided for use whenever it is desirable to return the three point hitch position control lever to the same operating position.

DROP CONTROL KNOB

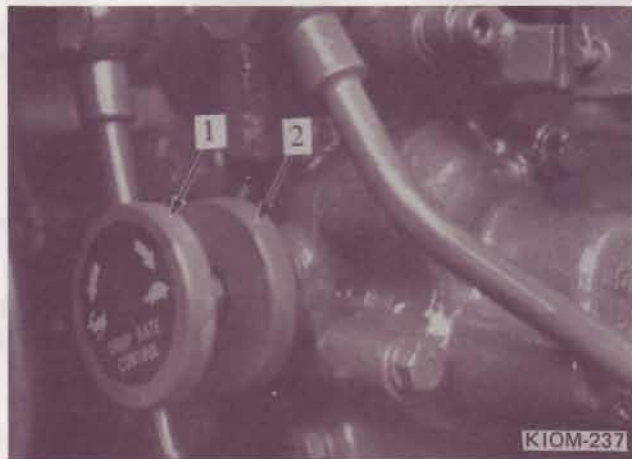

- 1 — Drop control knob
- 2 — Lock nut

The drop control knob is provided to adjust the lowering speed of the three point hitch.

When adjusting the lowering speed, loosen the lock nut and screw the drop control knob in or out.

Turn the knob clockwise to slow the rate at which three-point hitch lowers. Turn the knob counter-clockwise to increase the lowering rate.

After adjusting the speed, tighten the lock nut.

THREE POINT HITCH

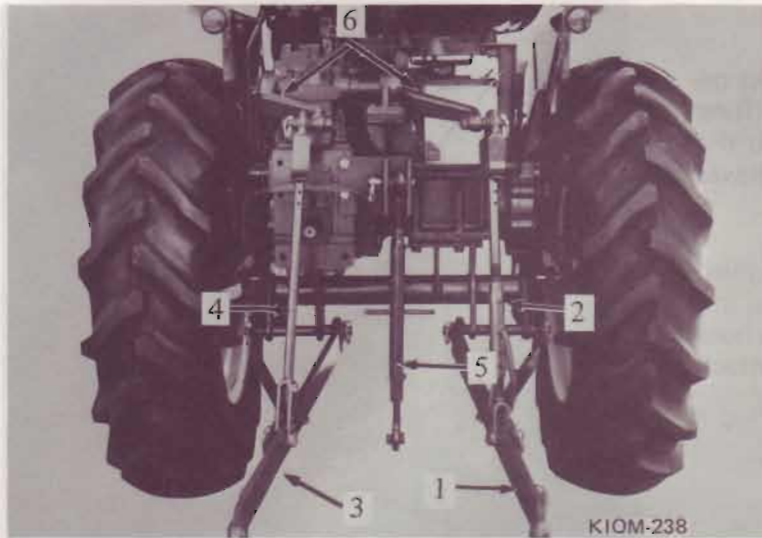

- 1 – Right lower link
- 2 – Right lift link-adjustable
- 3 – Left lower link
- 4 – Left lift link
- 5 – Upper link
- 6 – Rockshaft arm

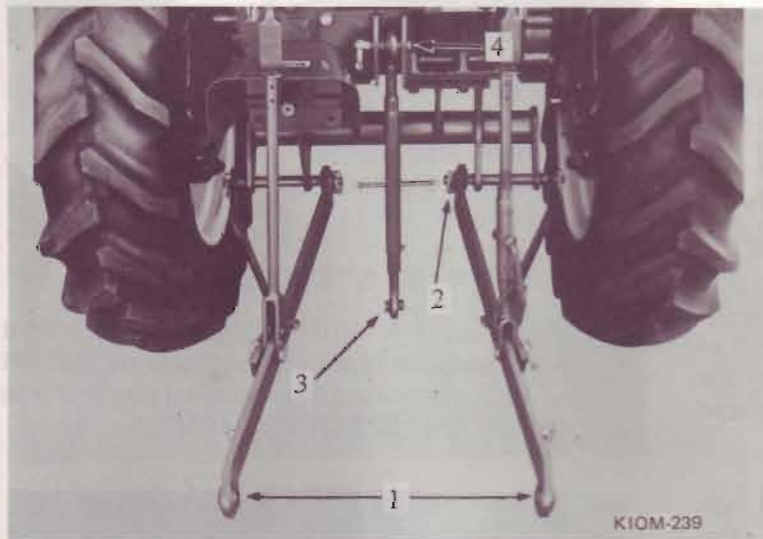

- 1 – Hitch holes (lower links)
- 2 – Link pins (lower links)
- 3 – Hitch hole (upper link)
- 4 – Link pin (upper link)

The tractor hitch has three points for attaching mounted equipment. Two points are for lifting the implement and the third point is for holding the implement level. The tractor hitch conforms to the specifications for category 1 tractor hitches established by American Society of Agricultural Engineers (A.S.A.E.) and Society of Automotive Engineers (S.A.E.).

"Hitch pins" and "hitch holes" refer to pins and holes used to attach the implement to the hitch. "Link pins" and "link holes" refer to pins and holes used to attach the hitch to the tractor.

THREE POINT HITCH

LOWER LINKS AND UPPER LINK

The hitch holes in the ends of the lower links on the tractor provide two mounting points for lifting the implement. Category 1 hitch pins fit into the holes. The link pins are used to connect the lower links to the tractor.

The hitch hole in the upper link provides the third mounting point of the three-point hitch. The implement hitch mast is attached at this point to hold the implement level. The link pin is used to attach the upper link to the tractor.

LOWER LINK ADJUSTMENTS

To level an implement from side to side, use the leveling screw handle to turn the leveling screw. When viewed from the top, turn clockwise to raise or counterclockwise to lower one side of the implement.

The left and right lift links are made "rigid" or "free to float" by the position of the quick-attachable pins in the lift link rod. When the lift links are "free to float", they allow oscillation of the hitch, from side to side. This is required by the disc harrow and equipment having wide spaced gauge wheels.

The left lift link provides two positions for 1 inch (25 mm) and 2 inches (50 mm) oscillations. The right lift link provides one position for 1 inch (25 mm) oscillation.

NOTE: In rigid position, vertical float to follow ground contour is provided by the floating action of the rockshaft. But both left and right lift links float simultaneously.

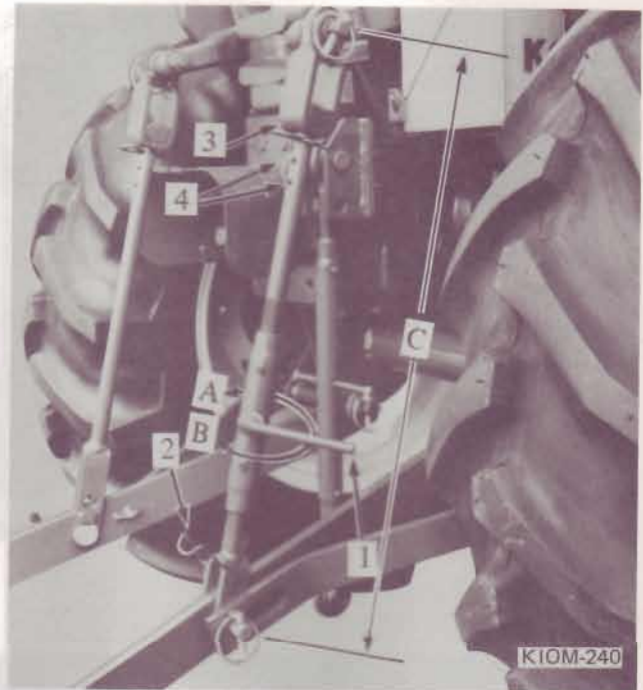

- 1 – Leveling screw handle
- 2 – Leveling screw handle lock
- 3 – Quick-attachable pin (rigid position)
- 4 – Pin hole for float position
- A – To raise
- B – To lower
- C – 23-7/16 - 27-5/16 in. (595 - 710 mm)

The fully raised or lowered height of an implement can be adjusted by changing the holes on the left lift link and by screwing the adjusting screw on the right lift link. See "SPECIFICATION".

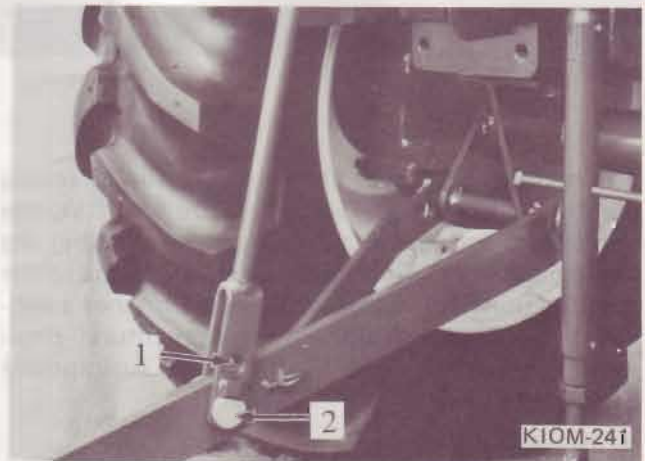

- 1 – Upper hole (left lift link)
- 2 – Lower hole (left lift link)

THREE POINT HITCH

UPPER LINK ADJUSTMENT

To level a mounted implement from front to rear, loosen the lock nut and shorten or lengthen the upper link, using the handle to rotate the link center section. Tighten the lock nut to prevent the adjustment from changing during field operation. See your implement operator's manual for specific instructions.

The length of the upper link can be adjusted from 20.7 to 28.5 inches (525 to 725 millimeters).

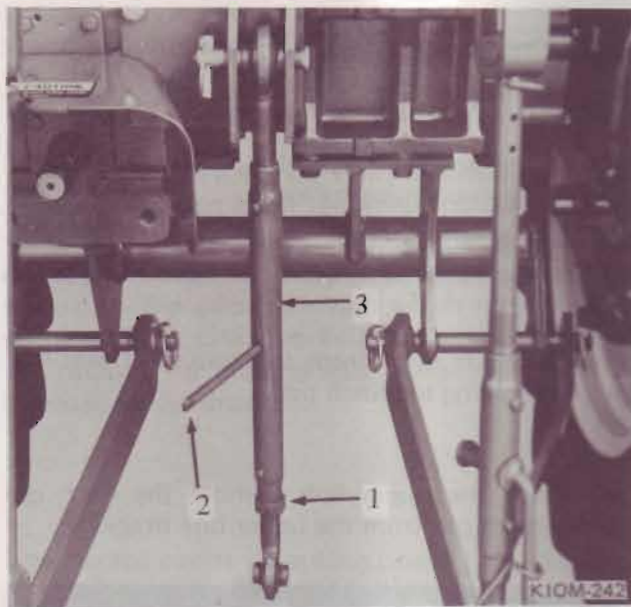

- 1 – Lock nut
- 2 – Handle
- 3 – Link center section

ATTACHING TO THE TRACTOR

All implements with Category 1 implement hitch mounting points can be attached to the tractor hitch.

The illustration shows the implement hitch mounting point dimensions specified by the Society of Automotive Engineers (S.A.E.) and American Society of Agricultural Engineers (A.S.A.E.) for Category 1 implement hitches.

Hitching an implement to the tractor is easier if both are on reasonably level ground.

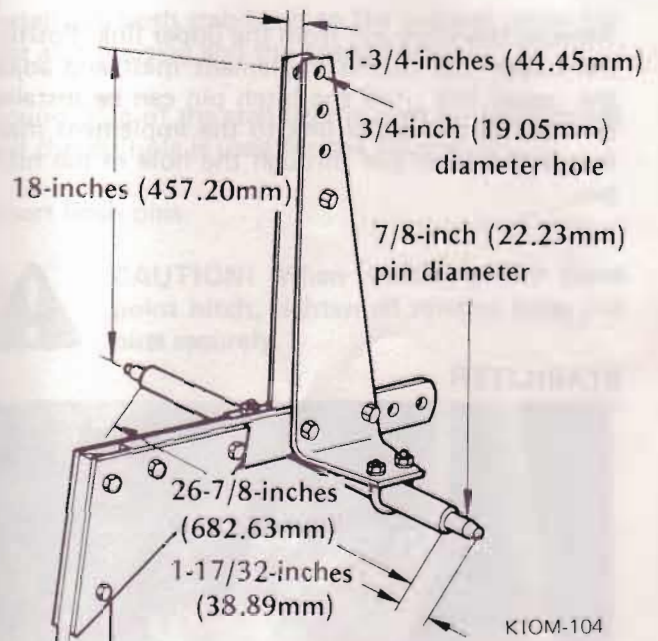

Back the tractor to the implement so the hitch holes in the lower links are in line fore and aft as close as possible with the implement hitch pins.

Lower the hitch, using the position control lever until hitch hole in the left lower link is in line with the implement left hitch pin.

Insert the implement left hitch pin into the hitch holes in the left lower link. Remove the linch pin from storage in the left lower link and install in the hole in the implement left hitch pin.

Using the leveling screw handle if necessary, insert the implement right hitch pin into the hitch holes in the right lower link, and install the linch pin.

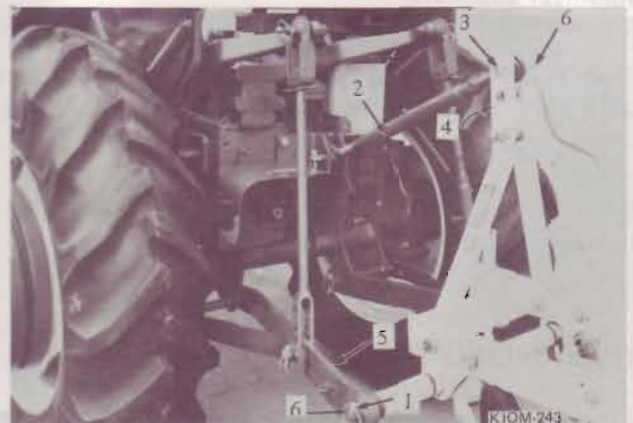

- 1 – Implement hitch pin
- 2 – Tractor upper link
- 3 – Upper link hitch pin
- 4 – Implement mast
- 5 – Tractor lower links
- 6 – Linch pin

THREE POINT HITCH

Remove the hitch pin from the upper link. Position the upper link in the implement mast and adjust the upper link until the hitch pin can be installed to connect the upper link to the implement mast. Install the hitch pin through the hole in the hitch pin.



CAUTION! Securely block the implement before disconnecting it from the tractor to prevent the implement from falling or tipping over, which could result in accident or injury.

REMOVING THE THREE-POINT-HITCH LINKAGE

If for any reason the three-point-hitch linkage is to be removed, proceed as follows:

Detach the stabilizers by removing the hitch pins which connect both ends of the stabilizer.

Remove the headed pins from the lift link lower ends.

Remove the hitch pin from the link pins for lower links on the transmission case.

This will release the lower links from the tractor.

Detach the lift links from the rockshaft arm link pin by removing the hitch pin.

To remove the upper link, remove the hitch pin and the hitch pin from the upper link bracket.

STABILIZER

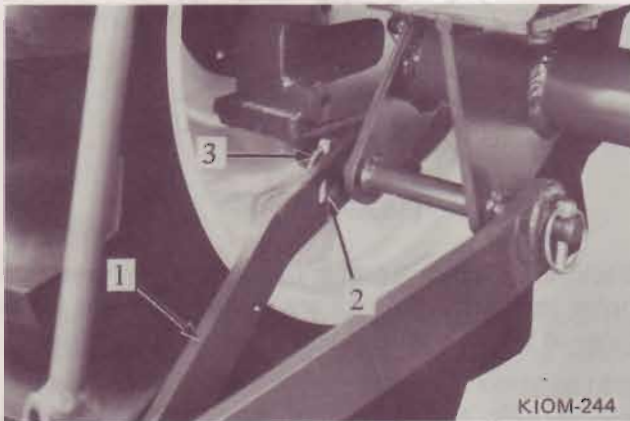

- 1 – Stabilizer
- 2 – Stabilizing Hole
- 3 – Non-stabilizing Hole

Lateral movement of the equipment is controlled by the stabilizers. Use the stabilizers as instructed in the equipment manual. The stabilizers are used with some direct-connected equipment.

Attach the front ends of the stabilizers to the stabilizer brackets.

Two holes are provided on stabilizer to connect with hitch lower link. When stabilizing hole is used, lateral movement is prevented.

When non-stabilizing hole is used, the hitch will have limited lateral movement.

UNCOUPLING THE IMPLEMENT

Lower the implement to the ground. Remove the pins from the three hitch holes. If the pins are difficult to remove, slightly raise or lower the hitch until the pins are free.

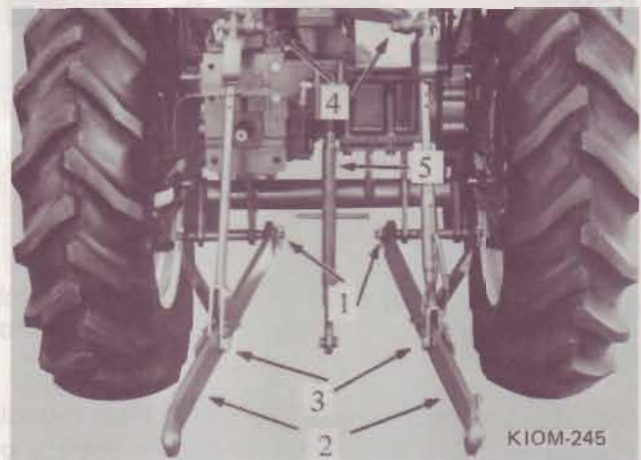

- 1 – Link pin for lower link
- 2 – Lower links
- 3 – Headed pins
- 4 – Rockshaft arm link pins
- 5 – Upper link

THREE POINT HITCH

INSTALLING THE THREE-POINT HITCH

Install the right and left lift links to the rockshaft link pins and insert linch pins.

Install the both lower links to the link pins on the transmission case.

Lift up another end of the lower link to position it in the slot of the lift link ends and insert the headed pins.

Install the both stabilizers to the bracket under the rear axle housing and the headed pins.

Round hole of the stabilizer is used for the bracket and the slit hole is used for the headed pin.

Insert linch pins.



CAUTION! When installing the three point hitch, tighten all relative bolts and nuts securely.

HITCHING TRAILING EQUIPMENT TO THE TRACTOR



CAUTION! Do not pull anything except 3-point hitch mounted equipment unless the tractor is equipped with the fixed drawbar. Pulling without a drawbar may cause the tractor to flip over backward which may result in serious injury. Drawbar bolts must be kept tight. All hitches for trailing-type equipment must be attached to the drawbar.

The tractor exerts its pulling power on pull-behind equipment by means of the fixed drawbar. Proper hitching will save both the tractor and the equipment it is pulling from undue strains. Make the hitch so that the center line of pull of the tractor will fall in line with, or at least be near, the center line of draft of the hitched-on equipment.

For PTO driven pull-behind equipment, the hitching point on the fixed drawbar must be in line with the tractor PTO shaft.

When using a long chain to hitch the tractor to the load, drive the tractor forward slowly until all slack is taken out of the chain.

A fixed drawbar is available for the tractor.

ATTACHING THE FIXED DRAWBAR TO THE TRACTOR

The fixed drawbar can be attached to the tractor final drive gear case with six capscrews.

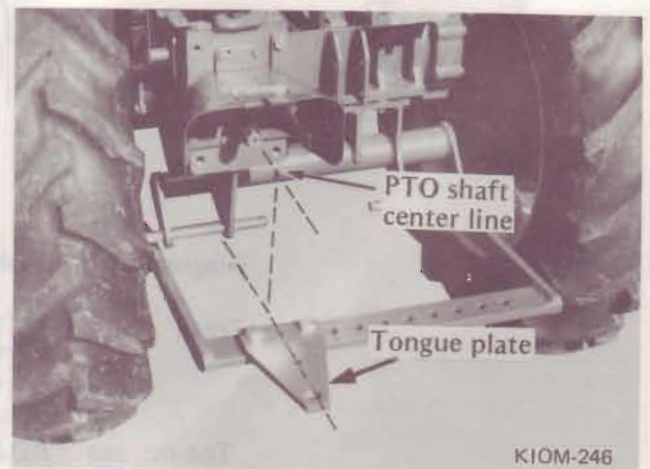

K10M-246

HITCHING TRAILING EQUIPMENT TO THE TRACTOR

ATTACHING THE DRAWBAR TO THE TRACTOR - Continued

Tighten the capscrews to a torque of 116 - 145 ft. lbs. (157 - 197 Nm)

Install the tongue plate onto the drawbar with two capscrews, washers and nuts.

Eleven holes are provided on the drawbar to install the tongue plate. When trailing a power take-off driven equipment, the tongue plate should be installed left end of the drawbar to align the tractor power take-off output shaft.

Tighten the tongue plate bolts to a torque of 361 - 448 ft.lbs. (490 - 607 Nm).



CAUTION! When using the drawbar, always ensure the drawbar bolts and tongue bolts are tightened securely.



CAUTION! With trail-behind PTO driven implements the drawbar tongue must be in line with the PTO shaft. If it is not, the driveline may pull apart.

FRONT WHEELS

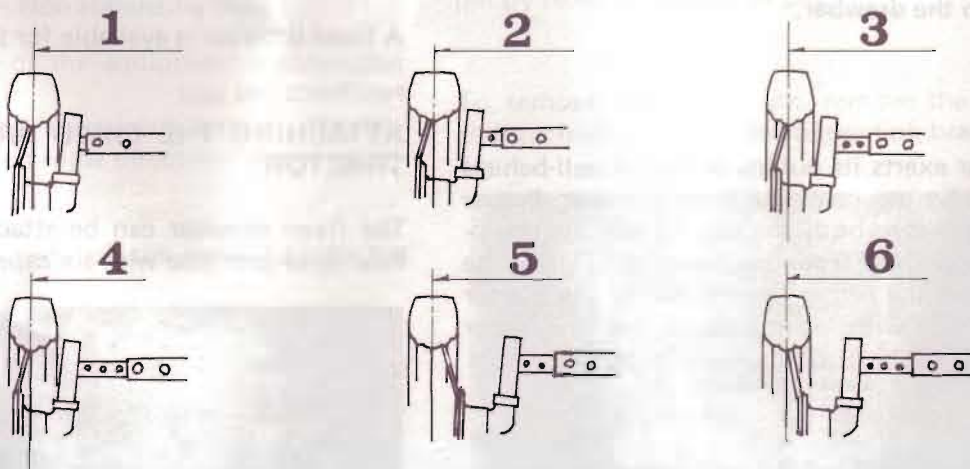

KIOM-247

Diagram of front wheel tread positions

Tread 1	— 44.9" (1140 mm)	2	— 48.8" (1240 mm)
3	— 52.8" (1340 mm)	4	— 56.7" (1440 mm)
5	— 60.4" (1535 mm)	6	— 64.4" (1635 mm)

Toe-in: see "ADJUSTING THE TOE-IN" under "PREVENTIVE MAINTENANCE".

FRONT WHEELS

The front wheels are disc wheels equipped with 5.50-16 tires.

The front wheels are tightened with six bolts to the hubs.

Check the bolts to keep them tight at the intervals recommended in the "PREVENTIVE MAINTENANCE GUIDE".

Bolt tightening torque: 72 - 90 foot pound (98 - 122 Nm).

The telescopic front axle is adjustable for treads of 44.9 to 56.7 inches (1140 to 1440 mm), using 5.50-16 tires, in 4-inch (102 mm) spacings with the wheel concaves turned in. Two additional tread settings are available with wheel concave turned out - 60.4" (1535 mm) and 64.4" (1635 mm).

The wheels are provided with mounting holes for the addition of cast iron weights.

NOTE: The front wheels must always be assembled with the concave side in when the tractor is carrying heavy front end weight.

ADJUSTING THE TREAD WIDTH

1. With the tractor on level ground, turn the steering wheel so that the both of the front tires are straight ahead. **See illustration.**

2. Jack up the front end of the tractor. And, securely place support block or sturdy jackstand under the front frame. **See illustration.**

3. Loosen nuts and remove axle extension bolts.

4. Loosen the lock nut and set screw on the tie rod.

5. Move the axle extension so the bolt holes coincide at desired tread position. Replace bolts "A" and tighten Nuts to a torque of 181~228 foot-pounds (245~309 Nm).

6. Move the tie rod to the position where both tires will be straight ahead, and tighten the set screw and lock nut.

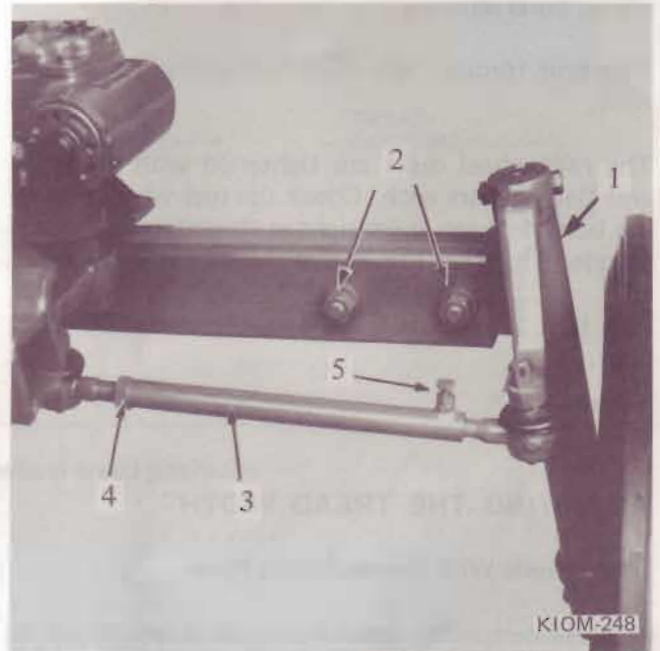

- 1 - Axle extension
- 2 - Axle extension bolts
- 3 - Tie rod
- 4 - Tie-rod lock nut
- 5 - Tie-rod set screw.

REAR WHEELS

NOTE: When the rims or wheels are reversed to change the tread width, change the tire and rim assembly or wheel to keep the tread of the tire pointing in the correct direction of rotation as shown by the arrow on the tire. Right rear wheel disc with wheel weight must always remain on right side.

When assembling the rear wheel rims, be sure to use the flat washer in assembly and tighten the clamp bolts securely.

Rim bolt torque: 181 - 228 foot-pound (245 - 309 Nm).

The rear wheel disks are tightened with six bolts and flat washers each. Check the rear wheel retaining bolts to keep them tight at the intervals recommended in the Preventive Maintenance Guide.

Hub bolt torque: 181 - 228 foot-pound (245 - 309 Nm).

ADJUSTING THE TREAD WIDTH

Disc Wheels With Demountable Rims

Rear wheels with demountable rims can be set to 44.5 (1130), 48.3 (1228), 51.7 (1312), 55.5 (1410), 53.6 (1362), 57.5 (1460), 60.8 (1544) and 64.6 (1642) inch (mm) tread positions by reversing the rims and bolting them on inner or outer side of the wheel. **See illustration.**

To adjust the rear wheels proceed as follows:

1. Block the front end of the tractor securely as shown.
The front end of the tractor should be blocked as shown by putting a wedges "A" and "B" as shown.



Blocking the front end of the tractor.

2. After the front end of the tractor has been securely blocked, jack up the rear end at "C" and "D".

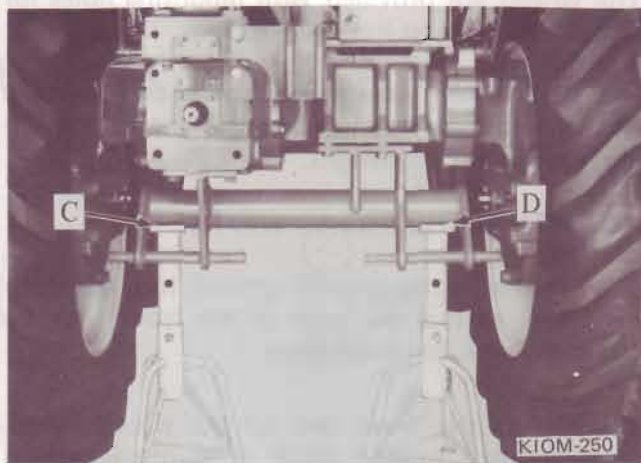

Rear end of the tractor

3. Remove and position the wheel and disc for the desired tread width. **See illustration.** Tighten all bolts securely and periodically check tightness.

REAR WHEELS

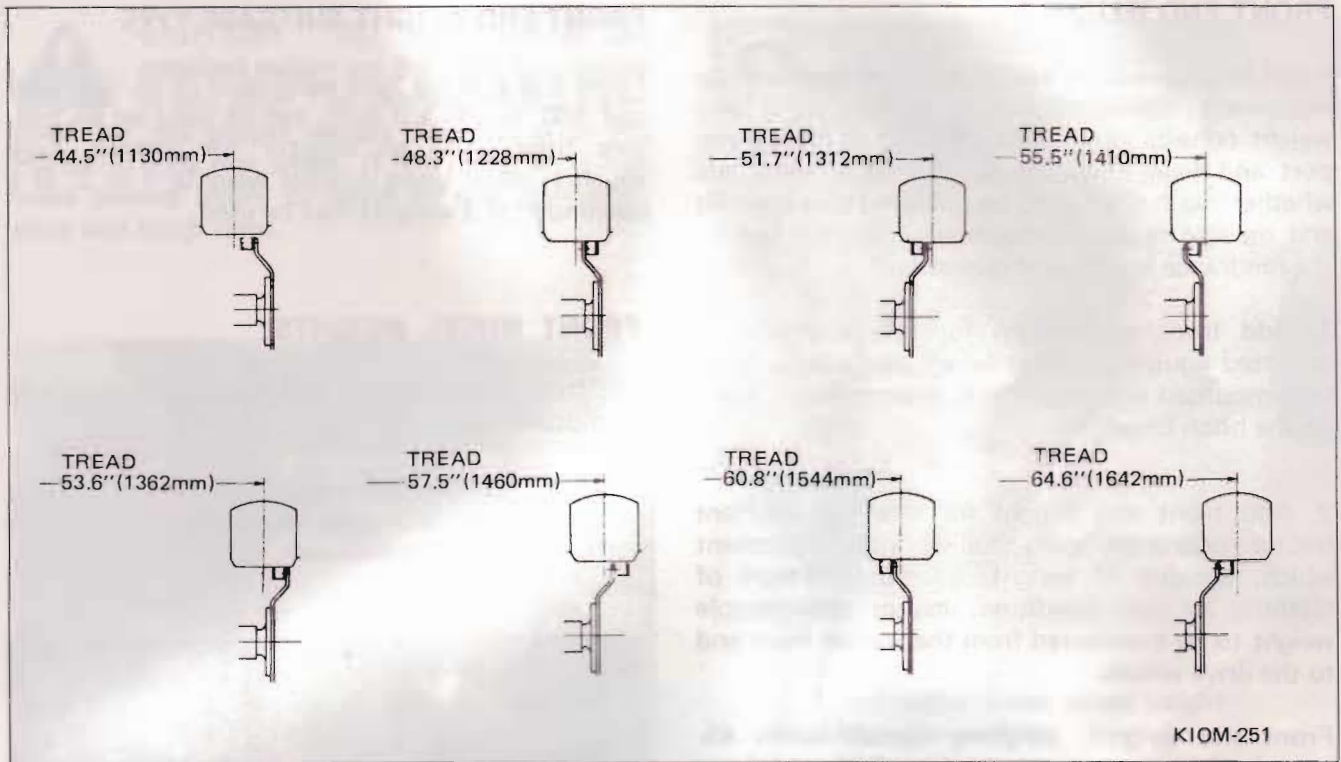

Diagram of rear wheel tread positions

NOTE: The arrow on the side wall of the tire is to point in the direction the tire will rotate with forward motion of the tractor. If the arrow does not point in the correct direction when mounting the tire and rim assembly at the desired tread width, exchange left and right tire and rim assembly.

Front and rear weights are available to provide safe and efficient operation with various equipment under different conditions.

WEIGHTS

This improved efficiency and overall reduction in cost is attained in the following:

1. More work done.
2. Less wheel slippage.

Rear ballast should be added to the tractor, to prevent excessive tire slippage and treadwear. The amount of rear weight needed will depend upon the type of soil or operating surface. However, excessive weight is not to be added to the rear

wheels to obtain continuous pulls in first gear which are greater than the maximum pull obtained in second gear.

NOTE: One rear wheel weight on the right hand wheel is a standard equipment of the tractor.



upset.

CAUTION! This tractor should always have a cast iron weight on the right rear wheel. This is to help prevent possible

Refer to "WEIGHT".

FRONT END WEIGHTS

Front end weights are available for use with various equipment combinations. In adding front end weight consideration must be given to both transport and field operation of the equipment, and whether the tractor is to be operated over the hills and on side slopes. Unnecessary front end weight is a hindrance to efficient operation.

1. Add front end weight for safe transport of mounted equipment with heavy rear overhang, or semi-mounted equipment that imposes heavy loads on the hitch lower links.

2. Add front end weight for safe and efficient tractor operation with soil-working equipment which, because of weight, position, method of hitching or soil condition, causes considerable weight to be transferred from the tractor front end to the drive wheels.

Front end weights, weighing approximately 45-pounds (20 kg) each, can be furnished, which are conveniently installed on a front weight adapter with mounting hardware. After putting the weights on, secure with M14 x 80 mm hex. head capscrews. See illustration.



Front End Weights

FRONT END WEIGHT-SUITCASE TYPE

Front end suitcase type weights of 75 lb. (34.5 kg) and 100 lb. (46 kg) each, can be used on all tractors fitted with an adaptor for suitcase type weights. When using suitcase weights, 1 or 2, or a maximum of 3 weights may be used.

FRONT WHEEL WEIGHTS

The front wheel weights weigh approximately 176 pounds (80kg) in all.

A set of front wheel weight, 45 pounds (20kg) each, includes four weights, eight 3-1/4 inches bolts, nuts and lock washers.



Front wheel weights

REAR WHEEL WEIGHTS

The rear wheel weights weigh approximately 77 pound (35 kg) each, and either one or two or three can be attached to each rear wheel to reduce slippage and increase drawbar pull. The increase in drawbar pull with a proportionate reduction in slippage varies with the type of soil.

The first rear wheel weight on the right hand wheel is a standard equipment and must not be removed.

WEIGHTS



CAUTION! DO NOT remove the standard weight on the right hand wheel at any time. The standard weight is provided for the proper weight distribution of the tractor to each rear wheel. If it is removed, it may cause serious injury or death by side tipping on slope and sharp turns.



Standard weight on RH wheel

The optional first rear wheel weight on the RH wheel is attached to the standard weight with four capscrews, and on the LH wheel it is attached to the rim disc with four capscrews lock washer and nuts (nuts inside of disc). The second and third wheel weights are attached to first and second wheel weight with four capscrews respectively. See illustration.

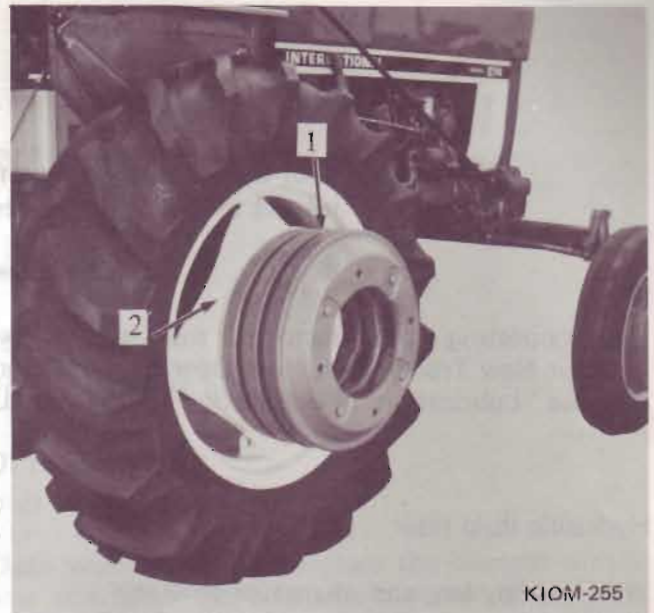

1. RH optional rear wheel weight
2. Standard weights



1. LH optional rear wheel weights

PREVENTIVE MAINTENANCE GUIDE

To keep your tractor performing efficiently, it is advisable to systematically inspect the following points at intervals as outlined below.

Before Operating the Tractor

Before operating a new tractor for the first time, be sure to follow the instructions given under "Breaking In Your New Tractor", "Before Operating the Tractor for Each Day's Use", and "Operating the Tractor". Also see "Lubrication", "Lubrication Table" and "Lubrication Guide".

After the First 10 Hours of Operation

- Hydraulic fluid filter Replace the filter.
- Water pump, fan, and alternator-generator belt Check tension.
- Wheel hub bolts Check and tighten to proper torque.
See "FRONT WHEELS" and "REAR WHEELS".

After Every 10 Hours of Operation

- Cooling system Check level of coolant in radiator.
See "COOLING SYSTEM".
- Lubrication points See "LUBRICATION GUIDE".

After the First 50 Hours of Operation

- Cylinder head nuts Check and tighten to proper torque. *
- Engine valves Check clearance. *
- Engine crankcase Drain and change oil

After Every 50 Hours of Operation

- Wheel hub bolts Check tightness. See "FRONT WHEELS" and "REAR WHEELS".
- Water pump, fan and alternator-generator belt Check tension; replace when necessary.

*See your International Harvester dealer for this service.

PREVENTIVE MAINTENANCE GUIDE

After the First 100 Hours of Operation

Hydraulic fluid filter Replace the filter.

After Every 100 Hours of Operation

Engine crankcase Drain and change oil.

After Every 200 Hours of Operation

Air cleaner element Clean when necessary. Replace the element with a new one after ten cleanings or one year service, whichever comes first.

Clutch pedal Check for free movement.

Hydraulic fluid filter Replace the filter.

Fuel filter Replace the filter.

Engine oil filter Replace the filter.

Storage battery Check liquid level. See "BATTERY".

Fan and alternator belt Check tension.

Water pump and governor belt Check tension.

Lubrication points See "LUBRICATION TABLE".

Periodic

Air cleaner body Clean when necessary.

Brake pedals Check for free movement and equal pressure. See "BRAKES".

Cooling system Drain, flush, and fill twice a year (spring and fall). See "COOLING SYSTEM".

Cylinder head bolts Check and tighten to proper torque.*
point opening; retime.

Engine manifold nuts Check and tighten if necessary.

Engine valves Check clearance.*

Front wheels Clean and repack wheel bearings with new grease once a year. See "LUBRICATION GUIDE".

Lubrication points See "LUBRICATION GUIDE".

*See your International Harvester dealer for this service.

PREVENTIVE MAINTENANCE

HOOD



1 – Hood open latch

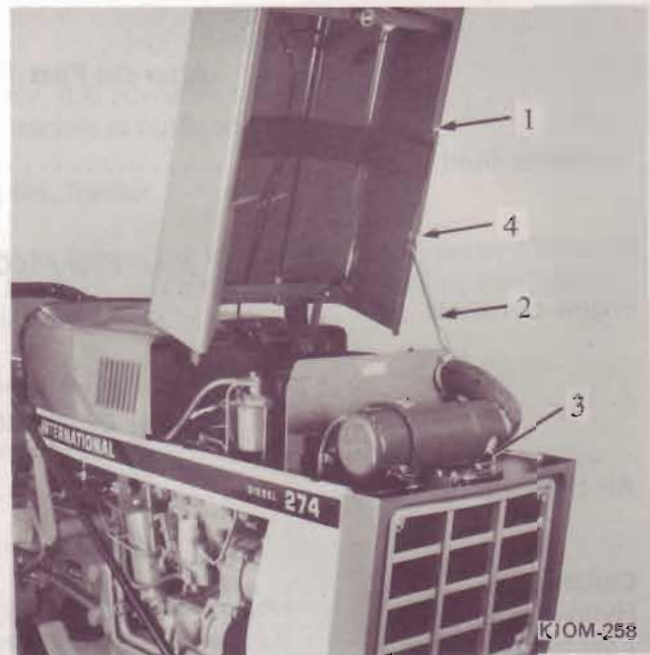

1 – Front hood
2 – Stay rod
3 – Latch
4 – Stay hole

Most inspection of the engine and its relatives for daily operation can be easily inspected by opening the front hood without removing the entire hood.

To open the front hood, pull the hood open lever to the left facing the front grill to release the latch.

Tilt up the front hood by hand and hold it. Then pick the stay rod up using the other hand. Insert the top of stay rod into the hole of the hood.

Ensure the rod supports the front hood securely and release your hand.

To close the front hood, support it by hand and store the stay rod in its home position, then lower the front hood slowly using both your hands. After the front hood contacts the front grill support, push it by hand to latch it securely.



CAUTION! Always ensure the stay rod is supporting the front hood in correct position securely while front hood is opened.

PREVENTIVE MAINTENANCE

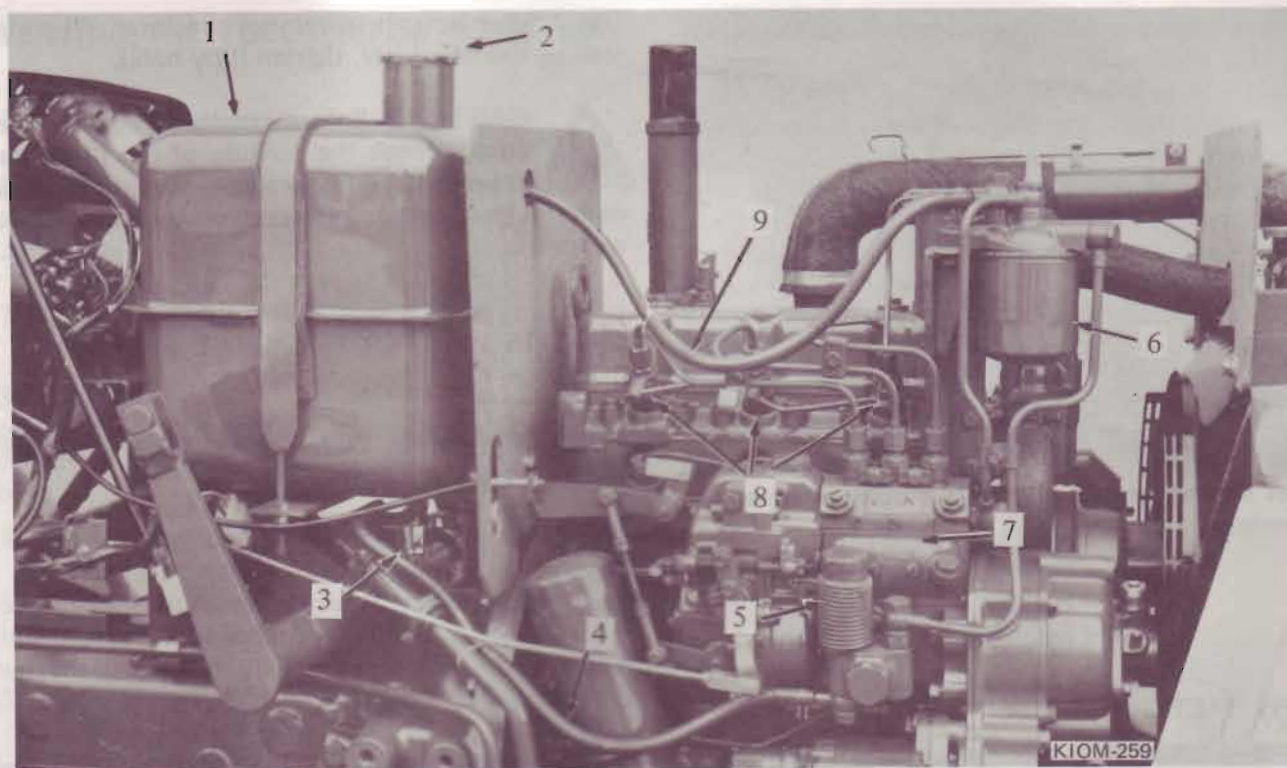

- | | | |
|--------------------------|-----------------------|-------------------------|
| 1 – Fuel tank | 4 – Fuel line | 7 – Fuel injection pump |
| 2 – Fuel tank filler cap | 5 – Fuel priming pump | 8 – Nozzles |
| 3 – Fuel strainer | 6 – Fuel filter | 9 – Fuel return line |

FUEL SHUT OFF VALVE

To close the shut off valve, turn the handle to the horizontal position.

To turn the fuel on, turn the handle to the vertical position.

FILLER CAP AIR VENT

The vent should be kept open at all times to relieve vapor pressure and assure proper flow of the fuel.

CLEANING THE FUEL STRAINER AND SEDIMENT BOWL



CAUTION! Clean the fuel system only when the engine is cool.

Clean the fuel strainer after every 200 hours of operation. To do this, proceed as follows:

1. Close the shut-off valve.
2. Take the strainer apart by loosening the nut under the sediment bowl.
3. Clean the sediment bowl and clean the screen if necessary.
4. When reassembling, be sure the gasket between the bowl and the main body is in good condition and does not leak. Use a new gasket if necessary.

PREVENTIVE MAINTENANCE

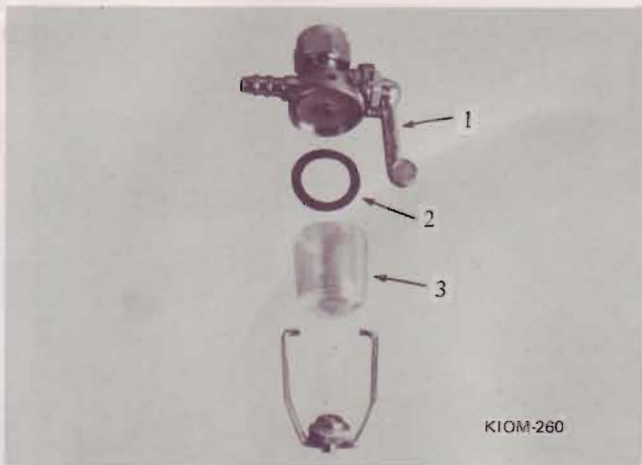

Fuel strainer showing the glass bowl removed for cleaning.

- 1 – Screen
- 2 – Packing
- 3 – Sediment bowl

FUEL FILTER



Fuel filter

The fuel filter is spin-on type filter. This filter can not be cleaned and should not be disturbed except when it becomes necessary to replace it.

Use a filter wrench to remove the filter. When installing the new filter, tighten it by hand.



CAUTION! Before replacing the filter, always clean the outside of the filter base thoroughly to prevent dirt or foreign material from entering the system when the filter is removed.

DRAINING WATER FROM THE SEDIMENT BOWL

Before starting each day's work, drain the water from the sediment bowl.

To do this, proceed as follows:

1. Close the shut-off valve.
2. Take the strainer apart by loosening the nut under the sediment bowl.
3. Drain the water from the sediment bowl and clean the screen if necessary.
4. When reassembling, be sure the gasket between the bowl and the main body is in good condition and does not leak.
5. Open the shut-off valve.

VENTING THE FUEL SYSTEM

All air must be eliminated from the fuel lines before the engine will start and operate properly. All plugs and fuel line connections must be tight to prevent leakage and to prevent air from entering the fuel system.

The system must be vented under the following circumstances:

Before starting an engine which has not been operated for an extended period of time. When the fuel filter has been replaced. When an engine, in operation, runs out of fuel.

When any connections between the injection pump and fuel tank have been loosened or broken for any reason.

PREVENTIVE MAINTENANCE

VENTING THE FUEL SYSTEM — Continued

To vent the fuel system proceed as follows:

1. Remove the vinyl cover of the priming pump and turn the knob counterclockwise, until it lifts up.
2. Loosen the vent screws using a driver.
3. Pump fuel into the fuel filter and injection pumps, using the priming pump by hand until fuel coming out of the vent screws is free of air bubbles.
4. Close the vent screws and lock the nuts.
5. Push the priming pump knob and tighten it by turning clockwise securely.
6. Apply the vinyl cover.

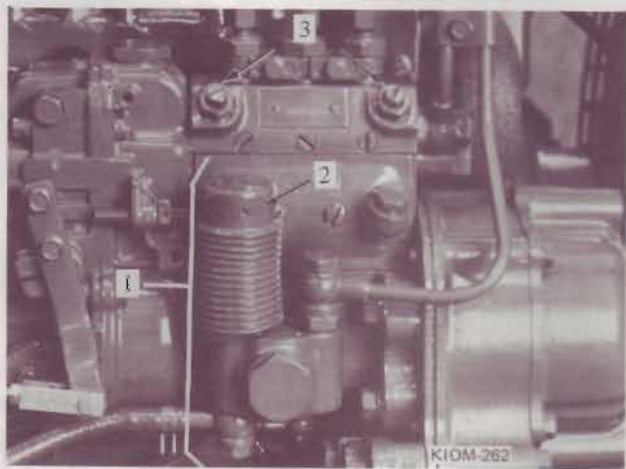

- 1 — Priming pump
- 2 — Priming pump knob
- 3 — Vent screws

COOLING SYSTEM

The tractor cooling system is water cooled, FORCED CIRCULATING SYSTEM.

The cooling system operates under pressure which is controlled by a regulating valve built into the radiator cap. To maintain pressure in the system be sure all connections are tight, there are no leaks in the system, the radiator cap is in good condition and tightened to the stop, and the radiator gasket surface is clean and smooth. If the radiator cap regulating valve is faulty, replace the cap with a new one of the same type.

ADDING COOLANT TO THE COOLING SYSTEM

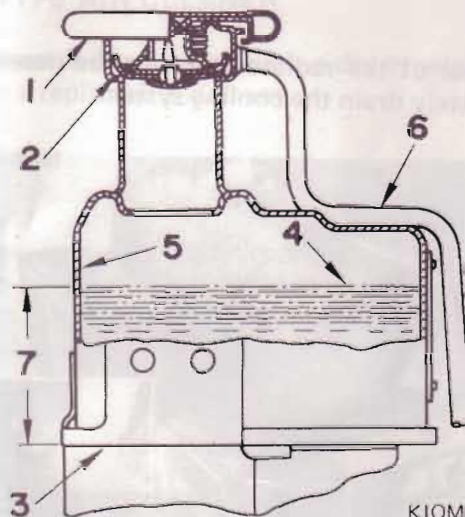

- 1 — Radiator cap
- 2 — Filler cap gasket
- 3 — Top of radiator core
- 4 — Water level
- 5 — Upper water tank
- 6 — Overflow pipe
- 7 — 1-3/16 inches (30 mm)

When the tractor is hot, turn the radiator cap counterclockwise to the pressure release point to allow the pressure escape, then press down on the cap and continue to turn until the cap is free to be removed.

Add coolant slowly to approximately 1-3/16 inch (30 mm) above the radiator core.

PREVENTIVE MAINTENANCE

ADDING COOLANT TO THE COOLING SYSTEM – Continued

Before replacing the filler cap, be sure to remove any chaff or dirt particles which may be on the gasket surface of cap, and tighten the cap clockwise to the stop.

NOTE: Do not use chemical mixtures to stop radiator leaks. Have the radiator repaired.

DRAINING THE COOLING SYSTEM

Remove the drain plug and allow the coolant to drain.

Removal of the radiator cap may be necessary to completely drain the cooling system.



- 1 – Radiator filter cap
- 2 – Drain plug (grill removed)

CLEANING THE COOLING SYSTEM

Once a year the cooling system should be drained, thoroughly flushed and cleaned with cooling system cleaner.

Cooling system cleaner dissolves rust, scale, and sludge and retards future corrosion when used according to the directions on the container.

FILLING THE COOLING SYSTEM

After the cooling system has been cleaned, install the drain plug and fill the radiator to a level. Use antifreeze protection year around, since it provides rust protection and water pump lubrication. Coolant should be changed annually to prevent loss of rust and anti-foam protection due to depletion of the antifreeze additives. For temperatures below freezing, use IH antifreeze according to the directions on the container for protection at the lowest expected temperature. Refer to "COLD WEATHER PRECAUTIONS". For cooling system capacity refer to "SPECIFICATIONS".

NOTE: When filling the cooling system with water or an antifreeze solution, use distilled or softened tap water whenever practical to reduce the formation of mineral deposits in the cooling system. Never fill the cooling system with water only or antifreeze only as either can be harmful to the cooling system.

Care of the Radiator:

To clean the radiator core, remove the grille screen and gently brush the accumulated material from the face of the core. If the spaces between the radiator fins becomes clogged, clean them with forced air or water.

FAN BELT TENSION

New belt should be checked after the first 10 hours of engine operation and every 50 hours of engine operation thereafter to assure maintenance of the correct tension.

The tension is correct when the belt deflection is approximately 3/8 in (10 mm), between the alternator pulley and the fan pulley.

PREVENTIVE MAINTENANCE

FAN BELT TENSION — Continued

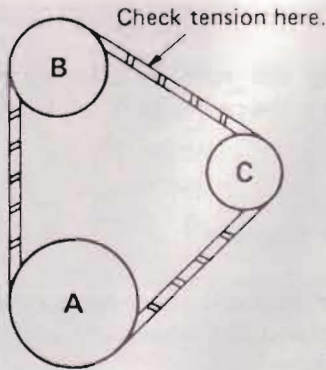

KIOM-116

- A — Crankshaft pulley
- B — Fan pulley
- C — Alternator pulley

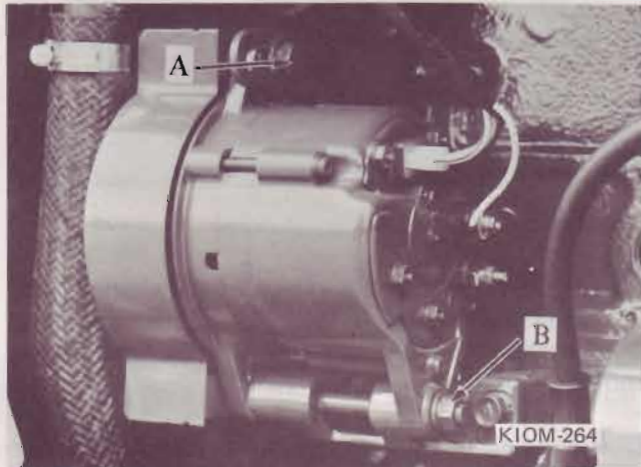

To adjust the belt tension, loosen brace bolt "A" and mounting bolt "B". See illust.

Move the alternator away from the engine until the tension on the belt is $3/8$ in (10 mm) to $19/32$ in (15 mm). Measured between the fan pulley and alternator pulley.

Tighten the brace bolt "A" and the mounting bolt "B"

Removing and replacing the belt

To remove the belt, loosen the alternator brace bolt and mounting bolt.

Move the alternator in toward the engine and slip the old belt off the alternator and crankshaft pulleys. Then work the belt over the fan blades to remove it.

Installation of new belt is in the reverse order of removal.

DRY-TYPE AIR CLEANER

Your tractor is equipped with a dry type air cleaner with a replaceable element.

Air Cleaner

Air entering the air cleaner body is swirled causing the large heavy particles to pass to the outer surface. The air then goes through the filter element which removes the remaining particles. The clean air then enters the intake manifold.



- 1 — Air cleaner body
- 2 — Cover
- 3 — Cover retaining clamp

PREVENTIVE MAINTENANCE

General Precautions

Frequently inspect all hose connections. If hoses show any signs of deterioration replace them.

All the joints between the air cleaner and the engine must be tight. All the gaskets must be in good condition and the bolts must be drawn up tight.

Never operate the engine unless the element is in place.

NOTE: Never attempt to remove the element from the air cleaner while the engine is running.

Removing the Filter Element

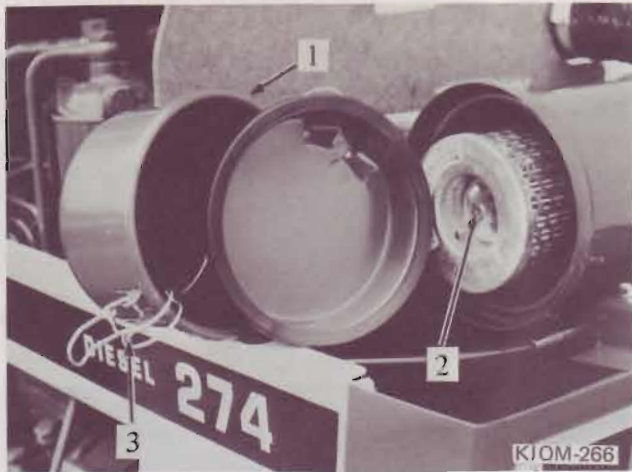

- 1 - Cover
- 2 - Wing bolt
- 3 - Clamp

1. Stop the engine.
2. Open the front hood by releasing the latch at front of hood with the hood open knob. See "HOOD" in "PREVENTIVE MAINTENANCE".
3. Loosen the two clamps and take off the air cleaner cover. See illustration.

4. Loosen the wing bolt and remove the filter element by pulling it straight out very slowly.

5. After replacing the new or cleaned element, install and tighten the wing bolt and clamp the cover in place.

Cleaning the Filter Element

NOTE: The paper element must be handled with care. It will not stand the abuse of rapping on a tire or hard surface.

1. Direct clean, dry compressed air up and down the pleats on the "CLEAN SIDE" (inside) of the element. Continue this until the element is clean.

NOTE: Air pressure at the nozzle must not exceed 100 pounds per square inch.

Replace the filter element after ten cleanings or annually, whichever comes first, with a new element supplied by your international Harvester dealer.

Inspection

1. Inspect the contact surfaces of the element and the air cleaner body. If faulty or damaged gaskets or surfaces are noted, correct these conditions immediately.
2. Remove any dirt, found inside the air cleaner body, with a damp cloth before reinstalling the elements.
3. Before resuming operation, inspect and tighten all air cleaner and air induction system connections.

ELECTRICAL SYSTEM

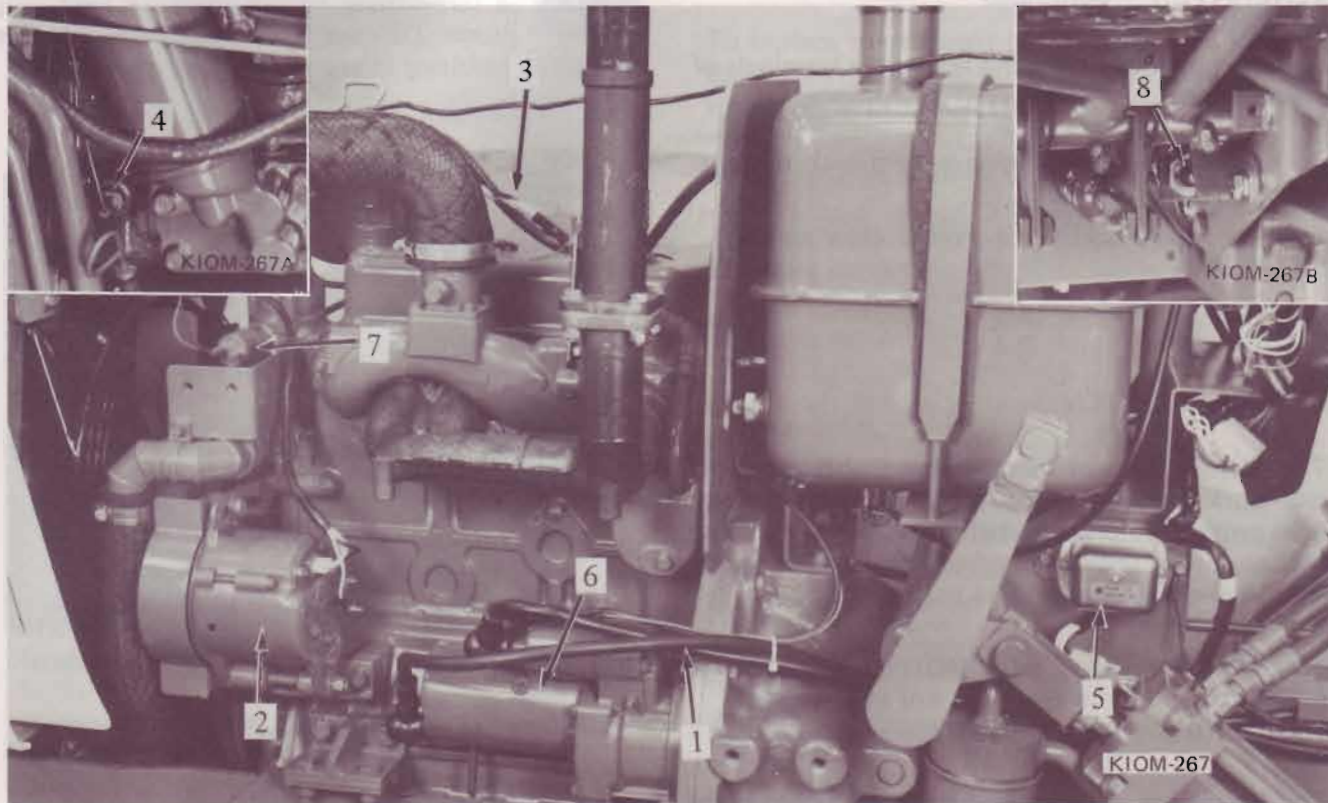

- | | | |
|--------------------------|-------------------------|---|
| 1 – Starter cable | 4 – Oil pressure switch | 7 – Water temperature unit |
| 2 – Alternator-generator | 5 – Voltage regulator | 8 – Starting safety switch
(Under the platform step) |
| 3 – Front cable harness | 6 – Starter motor | |

Electrical units and cable

The tractor electrical system is a 12-volt, negative ground system.



CAUTION! Before working on any part of the electrical system, disconnect the battery ground strap from the battery terminal. Do not reconnect it until all electrical work has been completed. This will prevent shorting and causing damage to any of the electrical units.

CHARGING SYSTEM AND ALTERNATOR-GENERATOR

The charging system consists of alternator-generator, charge indicator tellite, cable harness leads, and separate voltage regulator.

The alternator is hinge-mounted on the left side of the engine.

In order to assure satisfactory operation of the charging system, a periodic check should be made as follows:

Keep proper belt tension. Mounting bolts must be tight.

To prevent possible damage to the system avoid the following:

Do not polarize the alternator.

PREVENTIVE MAINTENANCE

CHARGING SYSTEM AND ALTERNATOR GENERATOR – Continued

Do not short-out or ground across the terminals of the alternator.

Do not operate the charging system with the output cable disconnected.

LIGHTING SYSTEM

The lighting system includes headlights, optional rear work lamp and taillight, flashing warning light, light switch, oil pressure tellite, water temperature tellite, charge indicator tellite, low fuel indicator lamp, fuses, harness lead and battery.

HEADLIGHT REPLACEMENT

The headlights are dual-element bulb whose bulbs are replaceable.

The headlight unit is held in position by a rubber retaining ring.

To remove a headlight unit, open the front hood and pull a rear portion of the lip of the rubber ring away from the edge of the headlight unit. Then, grip the exposed edge of the headlight unit and work the rest of the lip away backward.



CAUTION! Do not use any tool such as a screwdriver to pry the head light unit loose. Damage to the unit may cause it to shatter resulting in severe lacerations.

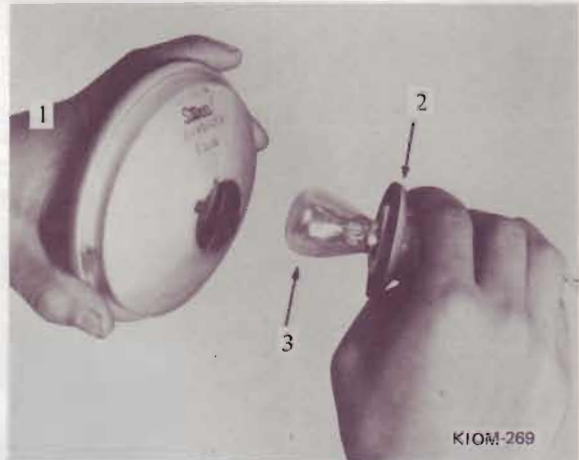

- 1 -- Lens
- 2 -- Socket
- 3 -- Bulb

Bulb Replacement

To remove a bulb from the headlight unit turn the socket counterclockwise and pull it out with bulb.

The bulb can be removed from the socket by pushing and revolving to release pins.

New bulb should be installed in the reverse order of removal. Bulb can be positioned to the socket correctly by coinciding bulb-pin to socket notch.

Socket is also positioned correctly.

Unit is marked "TOP" on the lens and has a protrusion to be properly oriented to the rubber ring.

PREVENTIVE MAINTENANCE

FLASHING WARNING LIGHT



- 1 - Lens
- 2 - Bulb
- 3 - Screw

The flashing warning light is on the left and right fenders.

Remove the screws and lens, and take out the bulb by pushing and turning counterclockwise.

The taillight is located on the left fender and provides a red light.

To replace the taillight bulb, remove the lens from the taillight and replace the bulb with new one. Refer to "SPECIFICATION".

REAR WORK LAMP (OPTIONAL)

The rear work lamp is turned on by the switch on the work lamp.

To replace the bulb, remove the lens from the work lamp by removing the screws on the lamp housing and separate the reflector from the lens.



CAUTION! The rear work lamp is for field use only and should not be used on the public roads.

TAILLIGHT

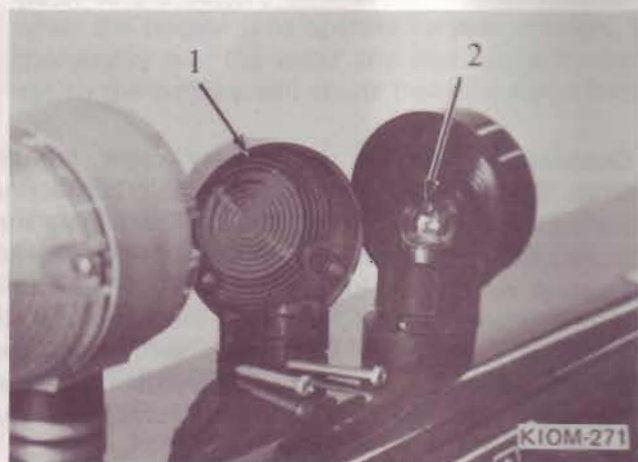

- 1 - Lens
- 2 - Bulb

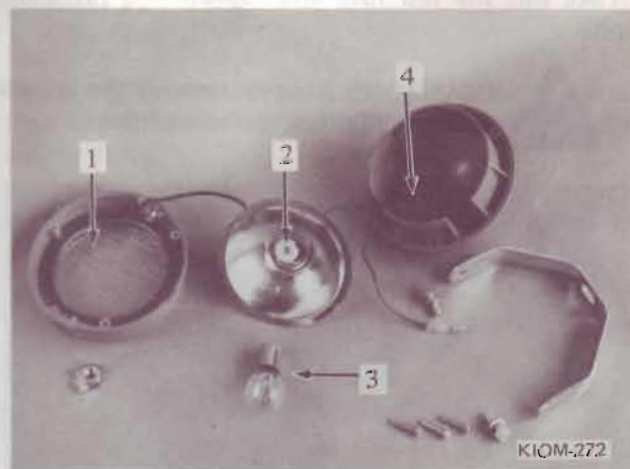

- 1 - Lens
- 2 - Socket
- 3 - Bulb
- 4 - Switch

The bulb can be removed by pushing and turning counterclockwise.

PREVENTIVE MAINTENANCE

FUSE

Three fuses are located in the fuse housing.

All fuses are cartridge type 3AG-10 fuses.

Left side fuse protects the circuits of headlight and panel light.

Center fuse protects the circuits of flashing lights, rear work lamp and taillight.

Right side fuse protects the circuits of water temperature tellite, oil pressure tellite, charge indicator tellite and low fuel indicator lamp.

If a short circuit occurs in the lighting circuit, the fuse will burn out and break the circuit, preventing damage to the electrical system.

It is important to use the same capacity fuse for replacement. If the lights fail, check the fuse. If the fuse continually burns out, check the electrical wiring for short circuits.

To install a new fuse, remove the fuse block cover by prying with a hand.

Take out the old fuse and replace it with a new one.



CAUTION! Always remove the ground strap first before replacing fuses.

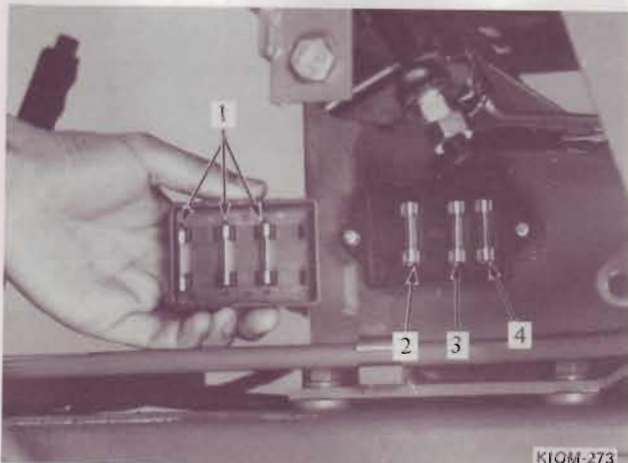

- 1 — Service fuses
- 2 — Left side fuse
- 3 — Center fuse
- 4 — Right side fuse

Three fuses can be stored in the fuse housing cover for service.

BATTERY

Major Items of Battery Care

Keep ground strap tight and free of paint and dirt.

To prevent corrosion, coat terminals with lubricant.

To prevent hard starting, keep terminals tight.

Keep battery filled to indicator level.

Cleaning and Servicing the Battery



CAUTION! Always remove the ground strap first and reconnect it last when servicing the battery. This prevents accidental shorting of the battery to the frame with the tool used to remove or install the terminal. Shorting can cause the battery to explode.

To service the battery, raise the operator's seat and open the battery cover.

To remove the battery, loosen the nuts on the battery hold-down bolts, and remove the cover.

Occasionally remove the battery cable ground strap. Brighten the terminal and cable contacting surfaces with wire terminal brush. Reassemble and surround the post and clamp with a light coat of vaseline or chassis lubricant. Be sure the cable terminals are clamped tightly on the battery posts and that the battery is fastened securely to the battery support. To prevent battery damage, keep the cover tight. Replace damaged cables. Keep the vent holes in the battery filler caps open.

When replacing a battery, make certain that the ground strap is connected to the negative (—) terminal on the battery.

PREVENTIVE MAINTENANCE

Liquid Level

For long battery life and trouble-free operation check the battery at 15-day intervals for water level. If the battery is in need of charging, it should be given immediate attention. Keeping the battery fully charged not only adds to its life but makes it available for instant use when needed.

The electrolyte (acid and water) in each cell should be at the proper level at all times to prevent battery failure. When the electrolyte is below this level, pure, distilled water should be added. Do not add any special battery "dopes", solutions, or powders.

For dependable battery service, see your International Harvester dealer.



CAUTION! Electric storage batteries give off highly inflammable hydrogen gas when charging and continue to do so for some time after receiving a steady charge. Do not under any circumstances allow an electric spark or an open flame near the battery, since it may cause the battery to explode.

Cold Weather Operations

It is especially important to keep the battery close to full charge for cold weather operation. Add water to the battery in freezing temperatures only when the tractor is to operate for several hours, to thoroughly mix the water and electrolyte, or damage to the battery will result from the water freezing.

A battery three-fourths charged is in no danger from freezing. Therefore keep the battery better than three-fourths charged, especially during winter weather.

If your tractor is not to be operated for some time during the winter months, it is advisable to remove the battery and store it in a cool, dry place above freezing temperature of +32° F. (+0° C). Place the battery on a rack or bench.

Connecting Booster Battery

When required, a booster 12-volt battery may be connected in parallel with the 12-volt system on the tractor.

NOTE: All circuits must be turned "off", Electrical System is NEGATIVE (—) grounded only. Reverse polarity will result in permanent damage to components of the electrical system.

NOTE: The positive terminal of the booster battery must be connected to the positive terminal of the tractor battery. The negative terminal of the booster battery should be connected to a point on the frame having a good ground, away from the battery, so no sparks occur near the battery.

NOTE: Connecting jumper cable to sources other than a good ground can result in serious damage to the tractor.

TELLITE BULB REPLACEMENT

Three tellite bulbs are in the tachometer panel.

These are oil pressure, charge indicator and water temperature.

These tellite should be turned on when the ignition key is turned to the "ON" position while the engine stops.

If the bulb is not lit, the circuit should be inspected. Replace the bulb if found broken.

To remove the bulbs, remove the steering post and instrument panel.

Remove the tachometer clamp nut and pull the rubber socket.

The bulbs can be removed from the socket by pushing and turning counterclockwise.

Install new bulbs in the reverse order of removal.

PREVENTIVE MAINTENANCE

TELLITE BULB REPLACEMENT – Continued

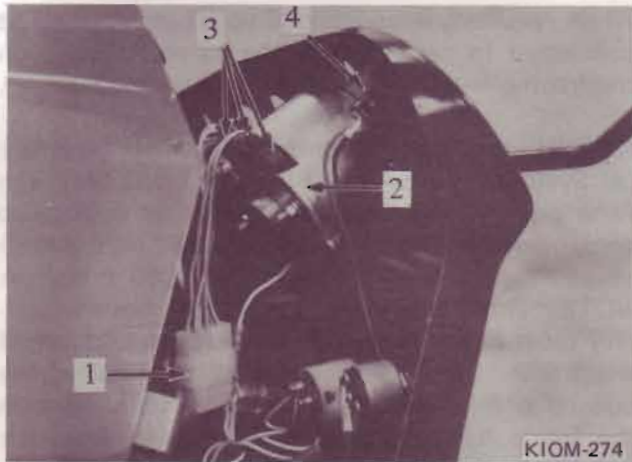

- 1 – Connector
- 2 – Clamp
- 3 – Rubber socket
- 4 – Low fuel indicator lamp

The low fuel indicator lamp can be removed with the socket by removing the lens.

The bulb can be removed from the socket by pushing and turning counterclockwise.

FRONT WHEELS

ADJUSTING THE TOE-IN

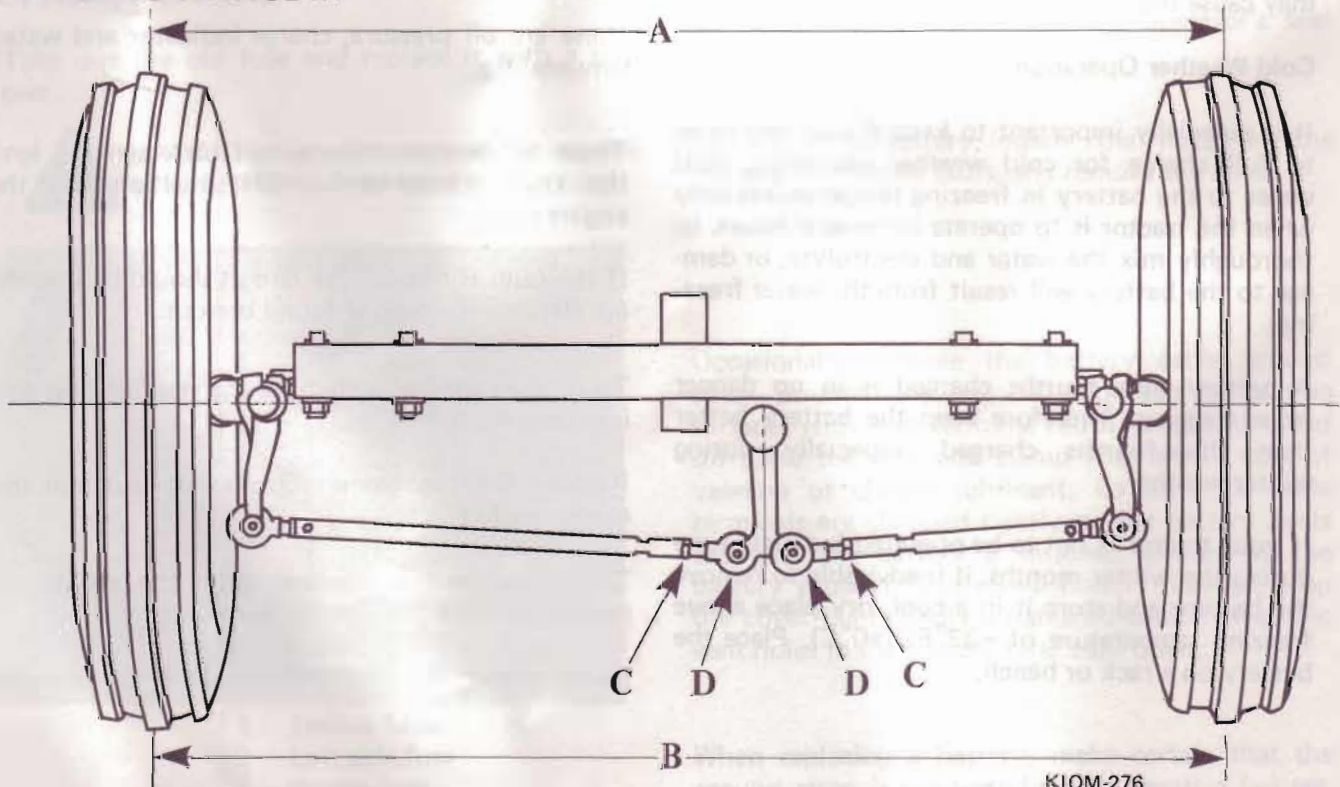

PREVENTIVE MAINTENANCE

ADJUSTING THE TOE-IN – Continued

The front wheels should have $5/32 - 3/8$ inch (4 - 10 mm) toe-in ($5/32 - 3/8$ inch closer in front than in the rear). To check the toe-in, place chalk marks at the point "A" on each tire at hub height, see illustration, and measure the distance between them. Move the tractor forward a distance equal to half revolution of the front wheels. The chalk marks should now be at point "B". The measurements between points "B" should be $5/32 - 3/8$ inch (4 - 10 mm) greater than at "A".

To adjust the "toe-in". Loosen the lock nuts "C", and disconnect the ball joints "D" by removing cotter pin and nut.

Turn the ball joints in or out as required, equally.

Be sure to make the arm adjustments equal and check to be sure steering arm stop on the axle.

TIRES

Observe the following instructions and recommendations for maximum life and efficient service from the pneumatic tires.



CAUTION! Read the operators manual thoroughly for proper installation, inflation and maintenance procedures.

Tires can explode.

MA-16880

CARE OF TIRES

Avoid stumps, stones, deep ruts, and other hazards. Cuts in tires should be repaired immediately, as neglect decreases tire life. Keep the tires free from oil and grease, as both destroy rubber. After using the tractor for spraying chemicals use water to remove any chemicals that may be on the tires.

INFLATION

Upon receiving your tractor, immediately adjust the air pressure in the tires as indicated in "SPECIFICATIONS".

Keep the pneumatic tires properly inflated. Underinflation will damage the tire cord body and may cause the tire to slip on the rim and tear out the tube valve stem. Overinflation results in excessive slippage, causing rapid tire wear.

Check the air pressure once a week with an accurate low-pressure gauge having one-pound graduations.

Always see that the tire valve caps are in place and are screwed tightly. The caps prevent the loss of air through the valve core, and keep loose soil, mud gravel, snow, and ice from entering and damaging the valve core.

Tires can be inflated with a pressure pump or hand pump.

SHIPPING TRACTORS EQUIPPED WITH PNEUMATIC TIRES

When tractors are transported on a carrier such as a railroad car or trailer, all tires could be overinflated.

The higher pressure must be reduced to operating pressure BEFORE the tractor is removed from the carrier. See "SPECIFICATIONS".

When equipment is mounted on the tractor, the rear wheel tire loads may be increased up to 20 percent with no increase in inflation as indicated in "SPECIFICATIONS" and speeds do not exceed 9.3 miles per hour (15 kilometres per hour).

PREVENTIVE MAINTENANCE

MOUNTING TIRES ON THE RIM

After mounting a new or old tire on the rim, inflate it to thirty pounds pressure to seat the tire bead on the rim flange and to keep the tire from creeping and shearing off the valve. Then deflate or inflate the tire to the correct operating pressure.



CAUTION! Never inflate beyond 35 pounds per square inch (241 kPa). If beads have not seated by the time pressure reaches 35 pounds per square inch (241 kPa), deflate the assembly, reposition the tire on the rim, re-lubricate and re-inflate. After seating beads, adjust inflation to recommended pressure. Allowing air pressure to build within the assembly in an attempt to seat the beads is dangerous practice. Inflation beyond 35 pounds per square inch (241 kPa) pressure may break the bead (or even the rim) with explosive force. Inspect both sides of tire to be sure beads are evenly seated. If not, completely deflate the tire, unseat beads and repeat entire mounting procedure.



CAUTION! Use clip on air chuck, extension hose with gauge and stand away from tire while inflating to prevent injury due to blow outs.



CAUTION! Mixing solution and changing tires can be dangerous and should be done by trained personal. See your IH dealer for this service.

TRACTION AND WEIGHTS

The tractor should not be operated with the tires improperly inflated. To insure the maximum hours of service, watch the tread lugs; if they wear down too fast, immediately add more weight to cut down slippage. Check for high air pressure. Consult your International Harvester dealer for information.

OVERLOADING

Do not overload the tractor tires by mounting implements on the tractor which exceed the load capacity of the size of the tires on the tractor.

BRAKE

The tractor is equipped with hydraulic actuated disc-type brakes. The brakes are controlled by foot pedals which can be operated individually, or simultaneously when latched together.

NOTE: The brakes are not intended for use in parking, or other stationary jobs since normal fluid seepage tends to release the brake. The park brake is provided for this purpose.

BRAKE ADJUSTMENT

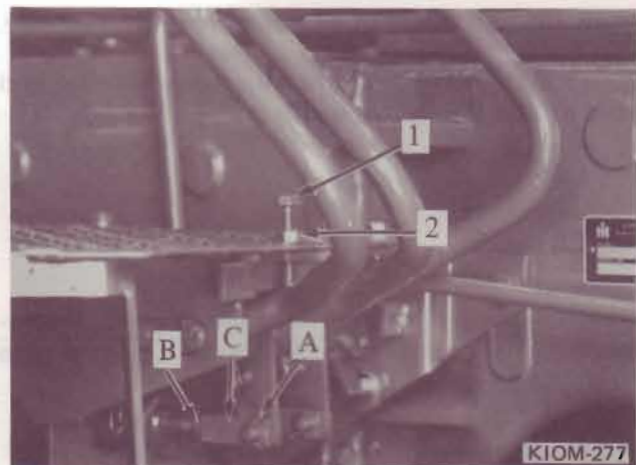

- 1 – Adjusting bolt
- 2 – Lock nut
- A – Pin
- B – Lock nut
- C – Yoke

Brake pedal adjustment

Adjust the brakes as follows:

1. Unlatch the brake pedals and compare the position of the left pedal with the right pedal.
2. If the left pedal is higher or lower, loosen the lock nut and screw the adjusting bolt in or out until both pedals align. Lock the nut.
3. Check the free travel of both pedals. The free travel must be 3/8 inch (10 mm).

PREVENTIVE MAINTENANCE

4. To adjust the free travel, take off the pin "A", loosen the lock nut "B" and turn the yoke "C".

5. After adjustment, tighten the lock nut "B" and insert cotter pin to the pin "A" thoroughly.

NOTE: Fluid for the brake is supplied to the master cylinder from the reservoir.

NOTE: Use IH-HY TRAN FLUID for the brake fluid.

If fluid is used which does not meet the requirements of IH B-6 specifications International Harvester Company will not be responsible for the warranty.

PARK BRAKE ADJUSTMENT

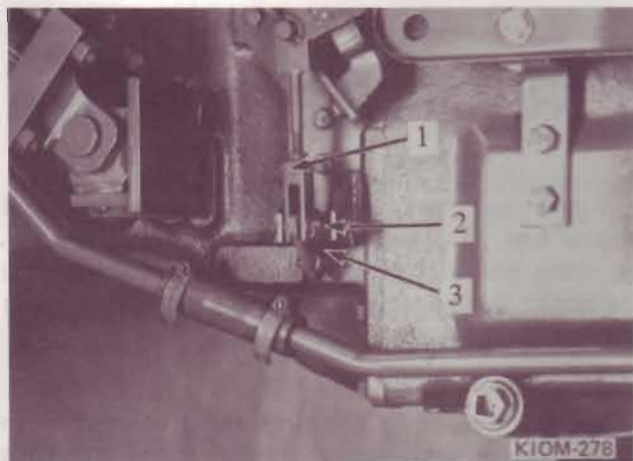

- 1 - Clevis
- 2 - Pivot pin
- 3 - Cotter pin

The parking brake must be fully applied when the lever has traveled 3 to 5 clicks up the ratchet. It will require adjustment when the lever can travel more than 6 clicks up the ratchet.

To adjust the park brake, release the brake and remove the cotter pin and the pivot pin. Turn the clevis in or out, then reinstall the pivot pin and the cotter pin.

BLEEDING THE BRAKE

This is not a routine operation and should only be necessary after the system has been disturbed allowing air to enter.

The bleeding procedure is as follows:

1. Attach one end of the transparent hose to one of a bleedscrews with the other end in a clean glass jar.

2. Press the pedal slowly several times so that the air comes to the bleedscrew.



CAUTION! Do not depress the pedal more than 3 inches (76 millimeters). Overdepressing may cause damage of the seal in the master cylinder.

3. Open the bleedscrew with the pedal depressed to allow air to come out.

4. Then, close the bleedscrew and release the pedal.

5. Repeat until no further air bubbles are issued from the bleedscrew.

6. Repeat the procedure at the other side.

7. Fill the reservoir with IH HY-TRAN FLUID to the specified level.

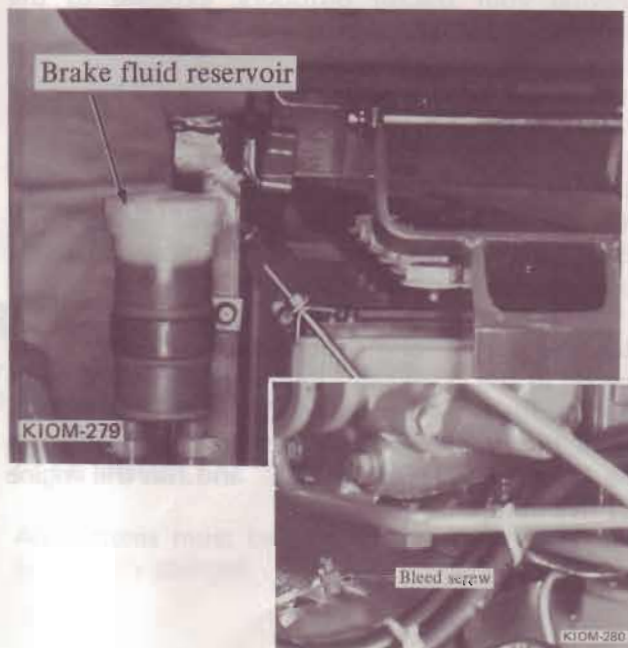

PREVENTIVE MAINTENANCE

CARE AND ADJUSTMENT OF THE ENGINE CLUTCH

As a result of normal clutch facing wear, the free travel between the clutch release levers and the release bearing is reduced. Lack of clearance causes excess slipping, overheating, and early replacement of the clutch facing.

Specified free travel is 1-3/16~1-3/8 inch (30~35 mm) measured at the front end of pedal.

Check the clutch for free movement after every 200 hours of operation until the proper inspection interval is determined according to usage. Check the free movement thereafter, as required, to provide proper clearance between the clutch release bearing and the clutch release levers.

Free travel should be adjusted before it reaches 5/8 inch (9.5 mm). It is adjusted by the yoke "A".

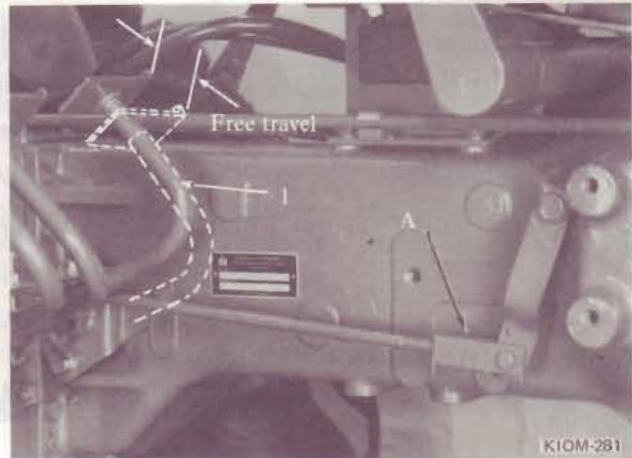

1 - Clutch pedal

Engine clutch adjustments

STORING THE TRACTOR

STORAGE

When your tractor is not to be used for some time, it should be stored in a dry and protected place. Leaving your tractor outdoors, exposed to the elements, materially shortens its life.

Follow the procedure outlined below when your tractor is placed in storage.

Wash or clean and completely lubricate the tractor. See the "LUBRICATION GUIDE". Apply IH 251H EP grease or equivalent rust inhibited grease to all exposed cylinder piston rod surfaces.

Run the engine long enough to thoroughly warm the oil in the crankcase, then drain the oil. Change the oil filter as instructed in "LUBRICATION". Refill the crankcase with fresh oil as specified in the "LUBRICATION TABLE" and run the engine for five minutes.

Fill the fuel tank with a premium grade diesel engine fuel. If this grade has not been used regularly, drain the fuel tank and refill. Run the engine for about five minutes to circulate the fuel through the injection system.

Store the tractor so the tires are protected from light. Before storing the tractor, clean the tires thoroughly. Jack up the tractor so the load is off the tires, when it is to be out of service for a long period. If not jacked up, inflate the tires at regular intervals.

Drain the engine cooling system and fill with a mixture of IH permanent type anti-freeze and water as specified on the container for the lowest expected temperature.

STORING THE TRACTOR

STORAGE – Continued

Clean the fuel strainer and sediment bowl.

Plug up the end of the exhaust pipe.

Plug the crankcase breather hose to seal the crankcase.

Clean the air cleaner as described under "AIR CLEANING SYSTEM". Cover the air cleaner to seal the air intake system.

Check the battery at least once a month for water level and specific gravity. Keep the battery close to full charge to prolong life and prevent freezing. Refer to "BATTERY".

Block or tie the clutch pedal in the fully disengaged position. This will keep the clutch facing from sticking to the flywheel or clutch pressure plate.

REMOVING FROM STORAGE

Be sure that the viscosity of oil in the engine crankcase is as specified in the "LUBRICATION TABLE".

Remove the plugs from the exhaust pipe and crankcase breather hose.

Remove the cover from the air cleaner.

Check the level of the coolant in the radiator.

See that the battery is fully charged and that the terminal connections are clamped tightly.

Release the clutch pedal.

Start the engine as described in "OPERATING THE TRACTOR" and let it run slowly. Do not accelerate the engine rapidly, or operate it at high speed immediately after starting.



CAUTION! Do not run the engine in confined areas such as storage buildings any longer than is necessary for immediate moving of the tractor into or out of the area. EXHAUST GASES ARE TOXIC. OPENING DOORS AND WINDOWS MAY NOT PROVIDE ADEQUATE VENTILATION.

COLD WEATHER PRECAUTIONS

When operating the tractor in temperatures of +32 degrees F. (0 degrees C.) or lower, observe the following precautions:

FUEL SYSTEM

Use only a winter grade fuel for ease of starting. Clean water from the sediment bowl. See "CLEANING THE FUEL STRAINER AND SEDIMENT BOWL" under "PREVENTIVE MAINTENANCE".

ELECTRICAL

All systems must be in good condition with batteries fully charged.

COLD WEATHER PRECAUTION

LUBRICATION

Be sure to use lubricant of the correct viscosity in the engine crankcase as specified in the "LUBRICATION TABLE".

COOLING SYSTEM

To prevent freezing of the cooling system, use IH permanent type anti-freeze. See "COOLING SYSTEM".

The use of alcohol as an anti-freeze is not recommended because methanol boils at +148 degrees F (64 degrees C).

NOTE: Use only one type of anti-freeze solution. Do not mix solutions, as it will be difficult to determine the exact amount of protection.

Never use any of the following in the cooling water as an anti-freeze—honey, salt, kerosene, fuel oil, glucose or sugar, calcium chloride, or any alkaline solution.

Refer to "SPECIFICATIONS" for the cooling system capacity.

ENGINE COOLANT HEATER (optional)

The block type engine coolant heater is available for an optional instrument.

The engine coolant heater can help protect an engine against damaging effects of cold starts and destructive effects of cold weather.

It operates on 115 volts.

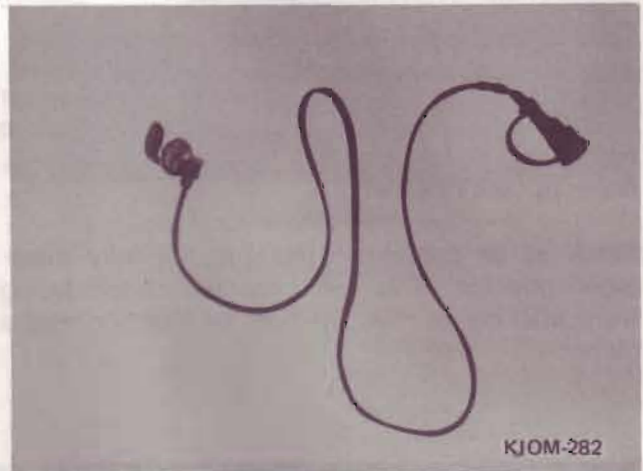

LUBRICATION

The life of any tractor depends upon the care it is given. Proper lubrication is a very important part of that care.

Tractors shipped to destinations in United States of America, Canada, and Mexico have the engine crankcase filled with shipaway oil.

Shipaway oil in the diesel tractor should be used for the first 50 hours of engine operation.

Thereafter, oil must be of proper viscosity for temperature specified in "LUBRICATION TABLE".

LUBRICATION

ENGINE OIL

SAE-10W or SAE-30 oil must meet API service classification CD or MIL-L2104C;

We recommend "I.H. No. 1[®] Engine Oil" for these engines. This oil is formulated from base oils and additives especially selected for maximum stability and minimum oil consumption. It is an API Service Classification CD-SE oil meeting MIL-L-2104C specification.

Engine oils under API Service Classification code are designated SA, SB, SC, SD, SE, CA, CB, CC, and CD. In this code, the prefix "S" denotes oils intended primarily for use in spark ignition (Gasoline-Lpg) engines mainly marketed through service stations and "C" denotes oils intended primarily for use in compression ignition (Diesel) engines mainly marketed through commercial distributors. The second letter relates to performance level. Some oils meet the API Service Classifications for both gasoline and diesel engines.

We recommend "I.H. No. 1[®] Engine Oil" for the engines. This oil is formulated from base oils and additives especially selected for maximum stability and minimum oil consumption. It is an API Service Classification CD-SE oil meeting MIL-L-2104C specification.

If other than "IH No. 1 Engine Oil" is used for diesel engines it must meet API Service Classification CD.

It is not the policy of the International Harvester Company to publish approved lists of lubricants. The responsibility for the quality of the lubricant, its performance under the conditions of operation, and its compatibility with the diesel fuels used must remain with the supplier of the lubricant.

High-speed diesel fuels and lubricants should be procured from a reliable source. When in doubt, consult your International Harvester dealer.

CHECKING THE OIL LEVEL

The crankcase has a bayonet-type oil level gauge. The oil level should never be above the "FULL" mark or below the "LOW" mark on the gauge. When checking the oil level the gauge must be

withdrawn and wiped clean, then inserted all the way and withdrawn for a true reading.

NOTE: Never check the oil level while the engine is running.

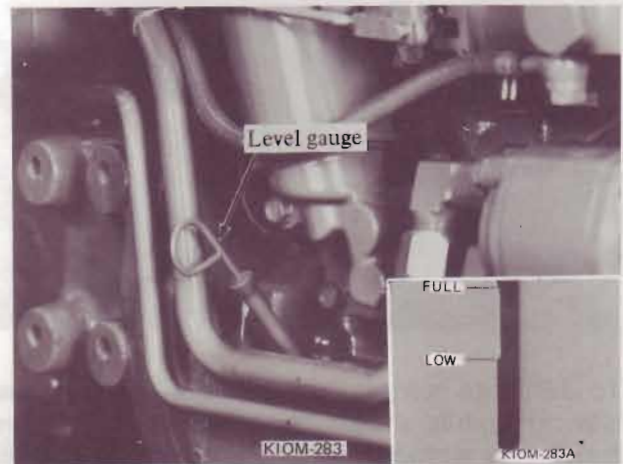

Engine oil level gauge

CHANGING ENGINE OIL

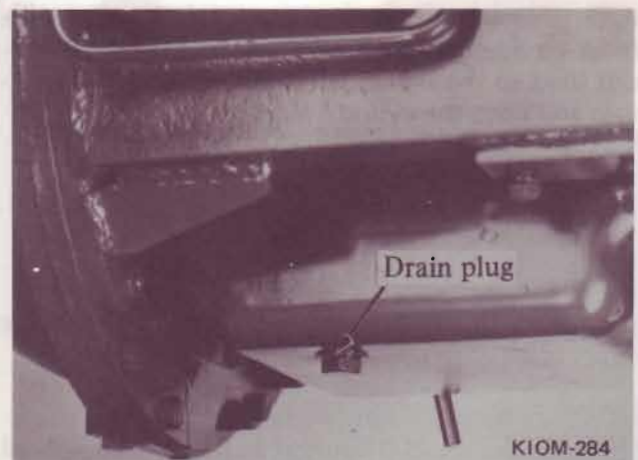

To facilitate starting, the selection of crankcase lubricating oils should be based on the lowest anticipated temperature for the oil change interval. It is not necessary to change the crankcase oil every time the temperature rises or falls into another temperature range during some part of the 24-hour day.

CHANGING ENGINE OIL — Continued



To facilitate starting, the selection of crankcase lubricating oils should be based on the lowest anticipated temperature for the oil change interval. It is not necessary to change the crankcase oil every time the temperature rises or falls into another temperature range during some part of the 24-hour day.

NOTE: After changing oil, the engine must not be operated at high speed or under load until the new oil has had ample time to reach all bearings.

After changing to a lighter grade of oil, the engine must be operated at least five to ten minutes without load so the lighter oil is worked into the bearings and onto the cylinder walls.

Also, see "COLD WEATHER PRECAUTION" and "LUBRICATION GUIDE".

Under normal operating conditions, change the engine oil after every 100 hours of operation.

NOTE: The engine oil change period may be extended to every 200 hours if I.H. No. 1 engine oil is used.

CHANGING THE ENGINE OIL FILTER

The engine is equipped with a spin-on type filter which continually cleans the oil while the engine is running.

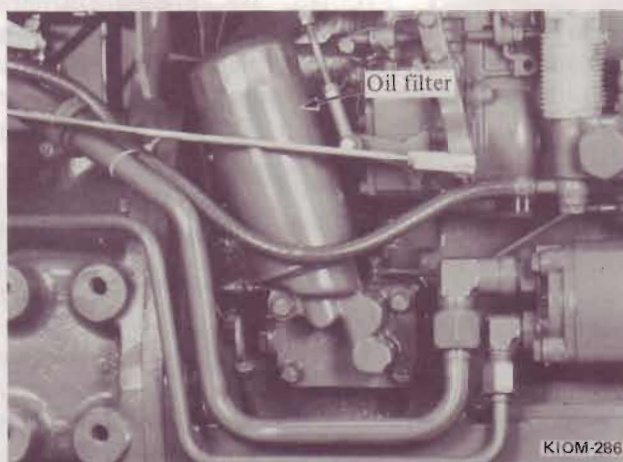

Spin-on type oil filter

Under normal operating conditions, replace the oil filter after every 200 hours of operation.

Remove the filter by turning counterclockwise. Discard the old filter. Apply a thin film of engine oil on the new filter gasket. Install the new filter on the threaded center tube by turning it clockwise until the gasket contacts the filter base. Hand tighten an additional 1/4 to 1/2 turn after the gasket contacts the filter base. Do not use tools to tighten the filter.

Start the engine and check the oil pressure tellite to see whether lubricating oil is circulating through the engine; then inspect the filter for oil leaks.

LUBRICATION

GEAR LUBRICANT

Tractors shipped from the factory to destinations in the United States of America, Canada, and Mexico are filled with IH Hy-Tran Fluid in the transmission and differential case, final drives, and hydraulic systems.

NOTE: Failures due to use of improper fluid or filters are not covered by warranty. **FOR MAXIMUM PROTECTION USE IH HY-TRAN FLUID AND FILTERS."**

Use IH Hy-Tran Fluid. If fluid is used which does not meet requirements of IH B-6 specification, International Harvester Company will not be responsible for substandard performance of the transmission and hydraulic components.

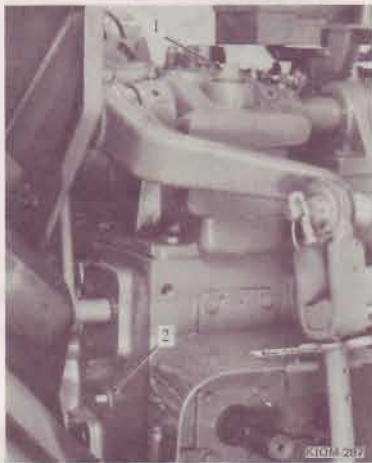

1 — Filler plug 2 — Level plug
for transmission and differential case

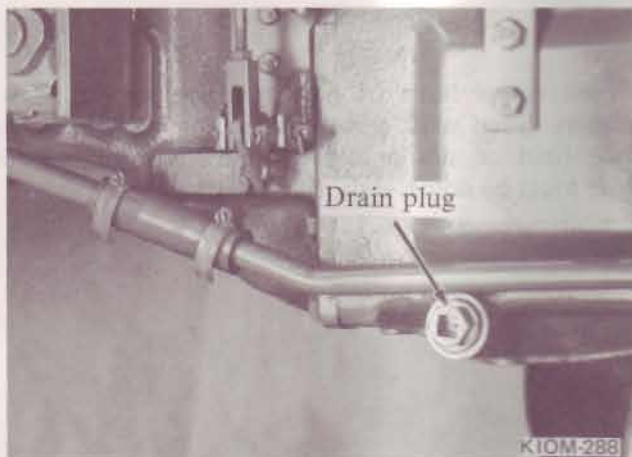

Drain plug
for transmission and differential case

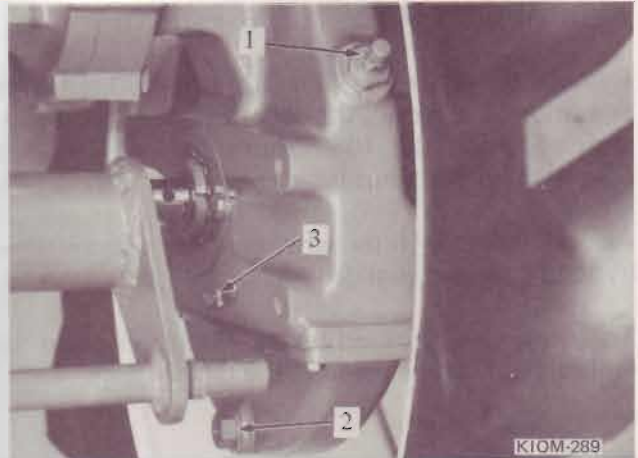

1 — Filler plug and breather 2 — Drain plug
3 — Level plug
for final drive case.

BREATHER SERVICE

Periodically the breather which is shown in the picture must be serviced to prevent false transmission oil level plug readings. Dust and trash that may accumulate in the area of the breather must be removed as required by operating conditions and always before removing the breather for cleaning.

Clean the breather with clean diesel fuel or kerosene and a soft brush. Dry the breather by shaking it. Replace the breather and secure.

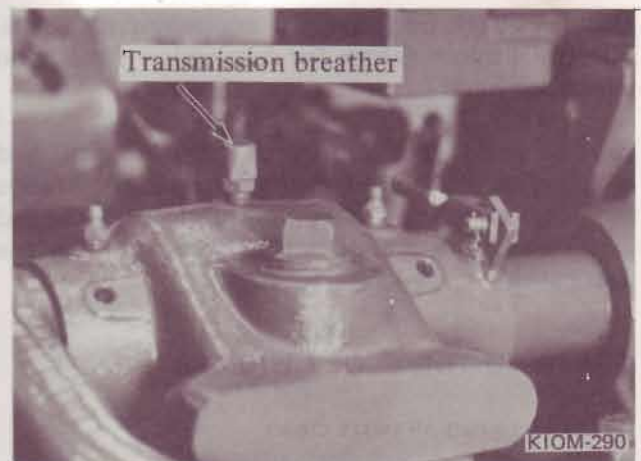

Transmission breather.

LUBRICATION

HYDRAULIC FLUID FILTER

Replace the filter the first 10, 100, 200 hours of operation and every 200 hours of operation thereafter. Replace the filter more frequently when operating under unusual dirt or dust conditions.

Also replace the filter whenever the transmission hydraulic fluid is changed.

To avoid delays, keep extra filters on hand so replacement can be made at the proper time.

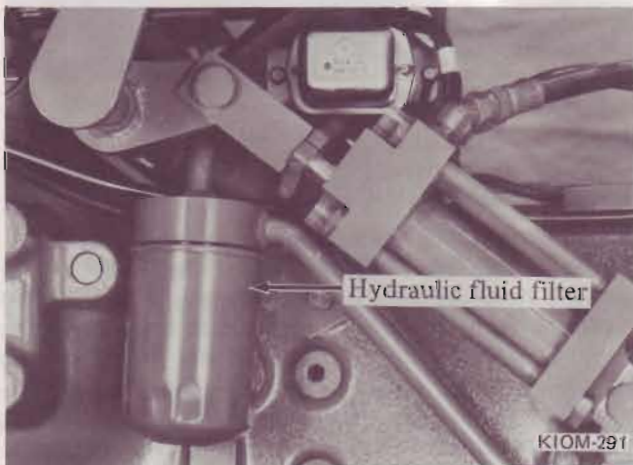

Hydraulic fluid filter.

LUBRICATION FITTING GREASE

Use IH 251H EP grease or equivalent #2 multi-purpose lithium grease for lubrication fittings on which the hand lubricator is applied.

NOTE: Keep your supply of lubricating oil and grease absolutely clean and free from dust. Always use clean containers. Keep the lubricant clean and wipe dirt from the fittings before applying the lubricator.

GREASING THE FRONT WHEELS

Be sure to keep all parts clean.

Once a year remove, clean and repack the front wheel bearings.

1. Block the front axle securely as shown to prevent it from swinging when one wheel is removed.

2. Lock the rear wheel by engaging transmission gear and park brake to prevent the tractor from running.

3. Raise the front end of the tractor until the wheels clear the ground. Remove hub cap "A", the cotter pin (G), nut "B" and washer "F".

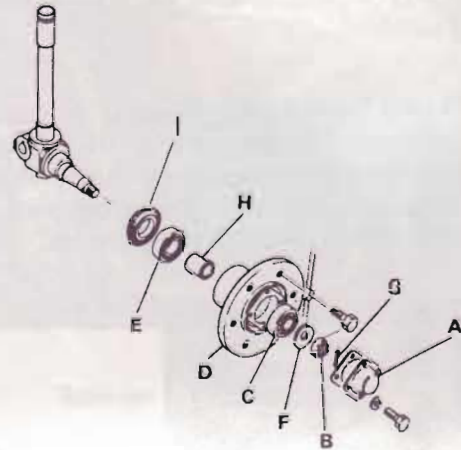

Wheel removed for cleaning and greasing

Remove the hub "D" with the bearings "C" and "E" and the seal "I" out of the knuckle. Then remove the bearings "C" and "E" from the hub.

Clean the inside of hub "D", remove the old grease from the bearings, clean them with kerosene, and repack with IH-251H EP grease, or equivalent #2 multi-purpose lithium grease.

Front wheel hubs of new tractors are not completely filled with grease. If tractor is operated in rice field or similar severe wet condition, wheel hub must be completely filled with grease.

LUBRICATION

Clean the bearings "E" and "C" with a brush and kerosene. Repack the balls with new grease before reassembling the bearings.

Inspect the oil seal and if it is not in satisfactory condition, replace it with a new one. A dirt deflector is also provided on the axle to prevent dirt from entering at the inner bearing.

Reassemble the wheel and tighten nut "B" to the torque of 51 ft-lbs (69 Nm). If the slot on the nut does not align the cotter pin hole, tighten the nut to next castellation to align the hole; replace the cotter pin and the hub cap.



LUBRICATION TABLE

Engine oils meeting standards as described under heading "Engine Oil" must be used in this engine.

Metric measurements are shown in parentheses.

Point of Lubrication	Capacity	Anticipated Air Temperatures		
		Above 32°F (0°C)	32°F to 0°F (0°C to -18°C)	Below 0°F (-18°C)
Crankcase +	5.3 qt. (5 liters)	I.H. No. 1 SAE-30	I.H. No. 1 SAE-10W	I.H. No. 1 SAE-5W-20 or SAE-5W-30 Do not exceed 100 hour oil and filter change. For prolonged full load operation SAE-10W must be used.
Front wheels	xxx	IH-251H EP grease or equivalent #2 multi-purpose lithium grease.		
Transmission and differential case (Also reservoir for hydraulic system)	Approx. 3.4 gal. (13.0 liters)	Use IH HY-TRAN Fluid		
Rear axle Final Drive Case	2.96 qts. (2.8 liters)	NOTE: Failures due to use of improper fluid or filters are not covered by warranty. "FOR MAXIMUM PROTECTION USE IH HY-TRAN FLUID AND FILTERS"		
Brake Fluid	xxx			
Lubrication Fittings	xxx	Use IH 251H EP grease or equivalent #2 multi-purpose lithium grease for fittings on which the hand lubricator is applied.		
Steering gear box	0.49 qt (0.46 liter)	SAE#90 Gear Lubricant		

NOTE: Add 0.5 qt. (0.5 liter) with filter change.

+ Do Not Substitute SAE-10W-30 or 10W-40

LUBRICATION GUIDE

The symbols around the reference numbers indicate the intervals of lubrication.

Metric measurements are shown in parentheses.

- ▲ - 10 hours ▮ - 100 hours ▭ - 200 hours ● - periodic

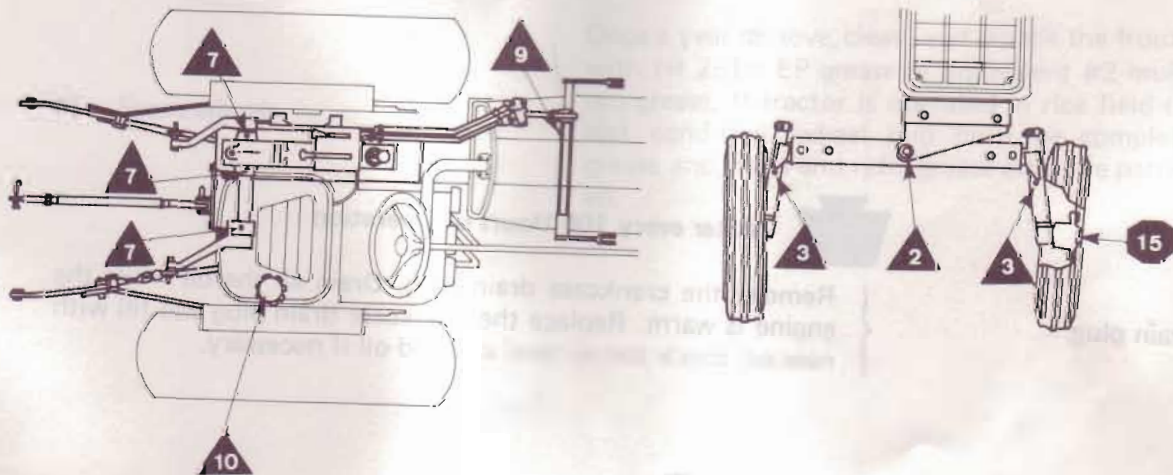
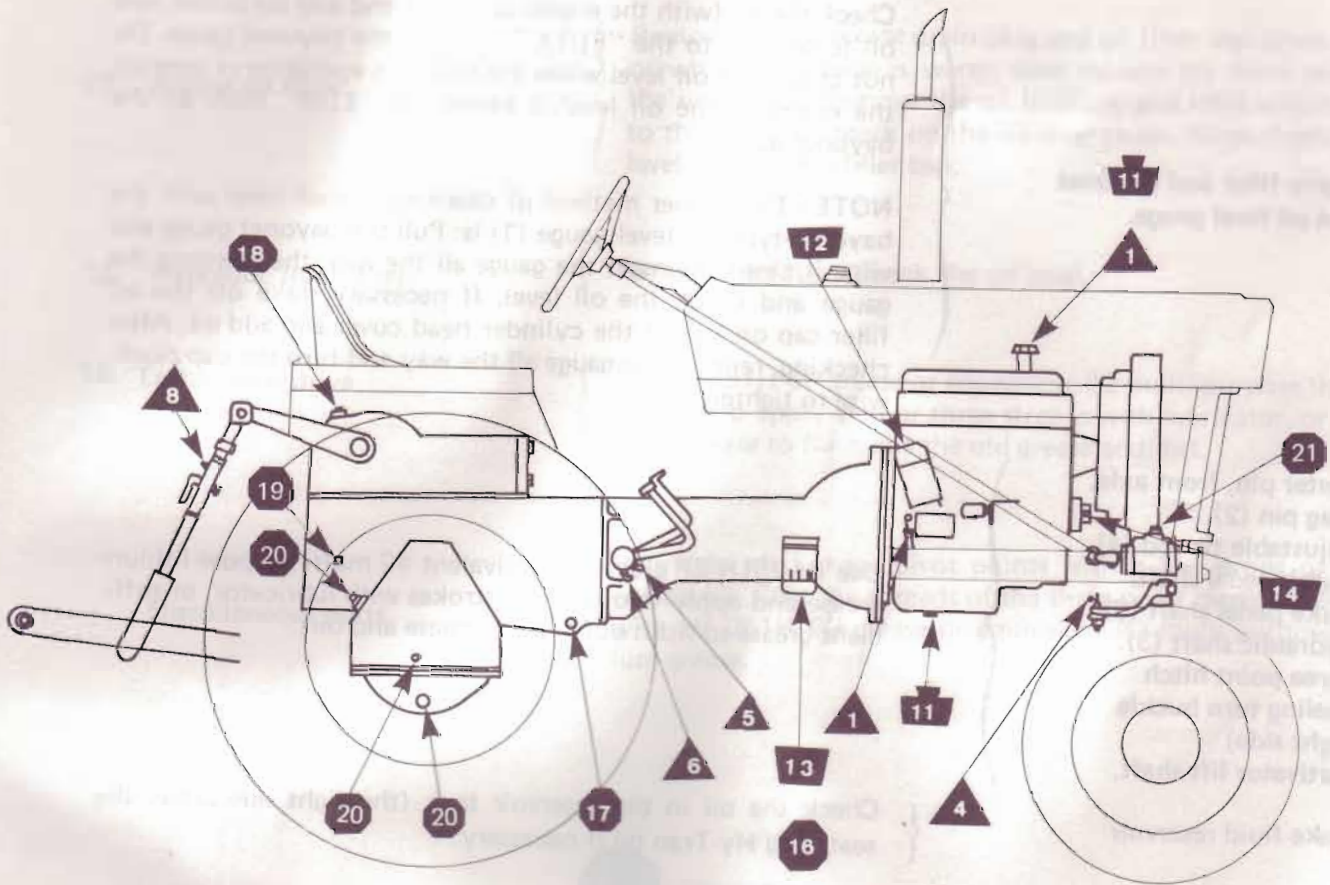

KIOM-293

LUBRICATION GUIDE

The symbols shown around the reference numbers in the illustrations indicate the intervals of the lubrication. Paragraph numbers correspond to reference numbers in the illustrations.

- Daily or After Every 10 hours of Operation

1. Engine filler and Bayonet type oil level gauge.

Check the oil (with the engine stopped) and add sufficient new oil to bring it to the "FULL" mark on the bayonet gauge. Do not check the oil level while the engine is operating or operate the engine if the oil level is below the "LOW" mark on the bayonet gauge.

NOTE: The proper method of checking the oil level with the bayonet-type oil level gauge (1) is: Pull the bayonet gauge and wipe it clean. Reinsert the gauge all the way, then remove the gauge and check the oil level. If necessary, take off the oil filler cap on top of the cylinder head cover and add oil. After checking, reinsert the gauge all the way and turn the cap clockwise to tighten it.

- 2. Center pin, front axle.
- 3. King pin (2).
- 4. Adjustable tie rod (4).
- 5. Clutch pedal shaft.
- 6. Brake pedal shaft (2).
- 7. Hydraulic shaft (3).
- 8. Three point hitch leveling turn buckle (right side)
- 9. Cultivator lift shaft.
- 10. Brake fluid reservoir

Use IH 251H EP grease or equivalent #2 multi-purpose lithium grease and apply two or three strokes with lubricator, or sufficient grease to flush out the old grease and dirt.

Check the oil in the reservoir tank (the right side under the seat) add Hy-Tran oil if necessary.

11. Crankcase drain plug.

- After every 100 Hours of Operation

Remove the crankcase drain plug. Drain all the oil while the engine is warm. Replace the crankcase drain plug and fill with new oil, check the oil level and add oil if necessary.

LUBRICATION GUIDE

NOTE: The engine crankcase drain period may be extended to every 200 hours if I.H. No1. engine oil is used.

12. Engine oil filter.

- After every 200 Hours of Operation

Remove the crankcase drain plug and oil filter and drain all the oil while the engine is warm; then replace the drain plug and the new filter. Remove the oil filler cap and refill with new oil to the "FULL" mark on the oil level gauge. After checking oil level, replace the filler cap.

13. Hydraulic fluid filter.

Replace the filter. Check the oil level.

14. Tachometer drive

Use IH 251H EP grease or equivalent #2 multi-purpose lithium grease and apply two or three strokes with lubricator, or sufficient grease to flush out the old grease and dirt.

Miscellaneous parts

Lubricate all linkage pivot points with a few drops of light engine oil. Coat the threads of the three-point hitch upper link with IH 251H EP grease or equivalent #2 multi-purpose lithium grease.

15. Front wheels.

- Periodic

Once a year remove, clean, and repack the front wheel bearings with IH 251H EP grease or equivalent #2 multi-purpose lithium grease. If tractor is operated in rice field or similar severe wet condition, wheel hub must be completely filled with grease and clean and refill grease after the particular job finished.

LUBRICATION GUIDE

- 16. Hydraulic filter.
- 17. Transmission drain plug.
- 18. Transmission filler plug
- 19. Transmission level plug

Remove the transmission drain plug and oil filter and drain all the oil; then replace the drain plug and new filter. Remove the oil filler cap on the hydraulic case and the transmission oil level plug on the left side of the rear frame, and refill with new oil until oil comes out the oil level plug hole. After checking, turn the cap and the oil lever plug clockwise to tighten them.

- 20. Rear axle final drive case filler plug, drain plug and level plug.

Remove the drain plugs on both LH and RH final drive case and drain all the oil; then replace the drain plugs. Remove the oil filler plugs and oil level plugs on the inside of the cases, and refill with new oil until oil comes out of the oil level plug holes. After checking, replace the level plugs and filler plugs and tighten them.

- 21. Steering gear box.

Remove the breather plug on the steering gear box and check the oil level. Correct level is approx. 1-1/4 in. (32 mm) under the gear box outer surface at the breather hole; correct level shows oil is filled approx. 0.49 qt. (0.46 liter). If necessary add SAE 90 Gear Lubricant from the breather hole and replace the breather.

Miscellaneous

Occasionally lubricate the engine control linkage, transmission control linkage, brake and clutch pedal pivot bushings, and control linkage with a few drops of oil.

SPECIFICATIONS

Metric measurements are shown in parentheses.

CAPACITIES (Approximate - U.S. Measure)

Fuel tank	8.7 Gal. (33 liters)
Water cooling system	1.8 Gal. (7 liters)
Crankcase pan	5.3 qt. (5 liters)
Transmission case	3.4 Gal. (13 liters)
Rear axle final drive case	1.48 qt. (1.4 liter) each
Steering gear box	0.49 qt. (0.46 liter)

ENGINE

Cylinder	3
Bore	3.27 in. (83mm)
Stroke	3.94 in. (100mm)
Engine speed (governed)	
Low idle speed	600-750 rpm
High idle (governed speed)	2760 \pm ₅₀ rpm
Full load (Governed speed)	2600 rpm
Valve clearance (engine cold)014 in. (.35mm)
Injection timing	20 degrees BTDC

GROUND SPEEDS (Maximum)

(Speed based on 12.4 — 24 pneumatic tire size and 2600 rpm engine speed)

(Speed will decrease with increased load)

Speed in mph (kilometre per hour):

	High Range	Low Range
1st gear	4.38 (7.05)	1.23 (1.98)
2nd gear	5.67 (9.12)	1.59 (2.56)
3rd gear	7.87 (12.7)	2.21 (3.55)
4th gear	11.7 (18.9)	3.28 (5.29)
Reverse	7.87 (12.7)	2.21 (3.55)

POWER TAKE-OFF SHAFT SPEED (Clockwise Rotation)

2160 engine rpm	540 rpm
2500 engine rpm	630 rpm

SPECIFICATIONS

Metric measurements are shown in parentheses.

BATTERY 70 Amperes

ELECTRICAL SYSTEM

System voltage	12 volts
Starting motor	2.0 kW
Alternator	20 Amperes
Voltage regulator	2 unit
Head and taillight switch	Rotary
Flashing warning light switch (optional)	Rotary
Head light	12 volts 45/45 watt
Flashing warning light	12 volts 15 watt
Taillight	12 volts 8 watt
Rear work lamp	12 volts 30 watt
Fuse (3 strap fuses)	10 amp
Tellite	12 volts 3.4 watt

CLUTCH

Single-plate, dry-disc, spring-loaded 8.5 in. (216 mm)

BRAKES

Foot brakes	Disc-type, hydraulic-ly actuated
Park brake	Lever operated, transmission locking

THREE-POINT HITCH

Category	Category 1
Lift links length	
Minimum	23-7/16 in. (595 mm) at right lift link
Maximum	27-5/16 in. (710 mm) at right lift link
Nominal	26-9/16 in. (675 mm)
Lower hitch links hitching pins	7/8 in. dia (22 mm)
Upper link hitching pin	3/4 in. dia (19 mm)
Upper link length	
Minimum	20.7 in. (525 mm)
Maximum	28.5 in. (725 mm)

SPECIFICATIONS

HYDRAULIC SYSTEM

Valves

Three point hitch	Position control valve
Mid-mounted cultivator lift	Double acting auxiliary valve
System relief pressure	1857 psi (12.794 mPa)
Pump output at engine 2600 rpm	5.7 GPM (21.5 liters/min.)

Specifications are subject to change without notice.

EXTRA EQUIPMENT AND ACCESSORIES

The tractor is used for so many different types of work and is called on to operate under so many different conditions that a considerable variety of equipment is necessary to adapt it to the varied requirements of the user.















When you purchased your tractor, you probably had it completely equipped for your particular needs at that time. However, later you may wish to obtain some of the equipment or accessories listed below. These items can be purchased from and installed by your International Harvester dealer.

Type of Equipment	Type of Equipment
Differential lock Fixed drawbar/3 pt hitch Engine coolant heater Front end weight-bumper type Front end weight-suitcase type	Rear wheel weight Rear work lamp Front tire 5.00 - 15 Rear tire 11.2/10 - 24 Seven pin connector

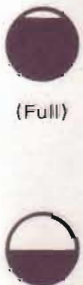
UNIVERSAL SYMBOLS FOR INSTRUMENTS AND CONTROLS

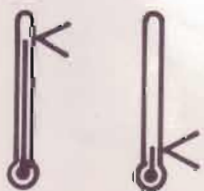
The International Harvester Company is using universal symbols to pictorially identify various instruments and controls. These symbols are an effort to overcome language differences for all operators in a positive way, thus enhancing their safety through quicker recognition of the instruments and controls while operating the equipment.

Study the following symbols so you will know their meaning immediately and at a glance.

			
Transmission Oil Pressure	Engine Oil Pressure	Water Temperature	Fuel
			
Speed Range	Sign	Fuel Shut-off	
			
Generator Light or Ammeter	Choke	Open Closed	Caution
			
Temperature	Volume Level	Hand Brake	Caution Pressurized - Open Slowly

MEMO

Accounts
can be presented
with help

Accounting is a systematic process
of recording, summarizing, and
reporting in terms of money
the financial transactions and
events which in part at least
are in part at least in part at least

The main purpose of accounting is
to provide information for the
management of the business
and for the determination of
the financial position and
performance of the business
and for the determination of
the financial position and
performance of the business

Accounting is a systematic process
of recording, summarizing, and
reporting in terms of money
the financial transactions and
events which in part at least
are in part at least in part at least

The main purpose of accounting is
to provide information for the
management of the business
and for the determination of
the financial position and
performance of the business
and for the determination of
the financial position and
performance of the business

MEMO

Accidents can be prevented with your help

No accident-prevention program can be successful without the wholehearted co-operation of the person who is directly responsible for the operation of equipment.

To read accident reports from all over the country is to be convinced that a large number of accidents can be prevented only by the operator anticipating the result before the accident is caused and doing something about it. No power-driven equipment, whether it be transportation or processing, whether it be on the highway, in the harvest field or in the

industrial plant, can be safer than the man who is at the controls. If accidents are to be prevented—and they can be prevented—it will be done by the operators who accept a full measure of their responsibility.

It is true that the designer, the manufacturer, the safety engineer can help; and they will help, but their combined efforts can be wiped out by a single careless act of the operator.

It is said that "*the best kind of a safety device is a careful operator.*" We ask you to be that kind of an operator.

