

# OWNER'S MANUAL



## FARMALL



**A** AND **AV**

This manual contains information which will be valuable to you during the entire life of your tractor. Rely on your manual for operating and maintenance information . . . and rely on your International Harvester dealer when in need of skilled mechanical service or genuine IHC service parts. A complete list of parts for this tractor will be supplied on request.

**INTERNATIONAL HARVESTER COMPANY**

180 NORTH MICHIGAN AVE.

CHICAGO 1, ILLINOIS, U.S.A.

---

# TO THE FARMALL OWNER

Please accept our congratulations on your investment in an International Harvester tractor as your new power partner. We feel sure you will obtain from this machine the economical and superior performance it is designed to give. It is certain that you will derive a large measure of personal satisfaction from operating it.

Years of tractor manufacturing experience and actual contact with agricultural problems in the field have been combined with advancements in engineering and metallurgical science to produce all the features and refinements built into your tractor. Properly adjusted, operated, and maintained, this tractor will respond to every reasonable demand you make upon it and give you reliable service for years to come.

The purpose of this Owner's Manual is to explain maintenance requirements and routine adjustments which are necessary for the most efficient operation of your tractor. To protect your tractor investment, study your Manual *before* starting or operating your tractor.

If you should need information not given in this Manual, or require the services of a trained mechanic, we urge you to use the extensive facilities offered by the International Harvester dealer in your locality. Dealers are kept informed on the best methods of tractor servicing and are equipped to provide prompt, high-class service in the field or in an up-to-date service station.

Dealers carry ample stocks of essential genuine IHC parts. These dealers are backed in every case by the full facilities of a conveniently located International Harvester branch.

When in need of parts, always give the International Harvester dealer your tractor and engine serial numbers. We suggest that you write these serial numbers in the spaces provided below, for ready reference when parts are required.

Tractor Serial No. \_\_\_\_\_  
(Stamped on plate on left seat support bracket)

Engine No. \_\_\_\_\_  
(Stamped on right side of crankcase above magneto)

\* \* \*

*It is the policy of International Harvester Company to improve its products whenever it is possible and practical to do so. We reserve the right to make changes or add improvements at any time without incurring any obligation to make such changes on tractors sold previously.*

---

# CONTENTS

Description	Page No.
Before starting a new tractor .....	3
Cold weather operation .....	18
Antifreeze solutions .....	18
Draining the cooling system .....	18
Fuel system .....	18
Lubrication .....	18
Driving the tractor .....	15, 16
Gear shifting .....	15
Operating precautions .....	6, 7
Starting the tractor .....	15
Stopping the tractor .....	16
Lubrication (see "Lubrication Chart") .....	Center of manual
Operation of a distillate-gasoline engine on distillate .....	10 to 13
Fuel system .....	10
Manifold heat control .....	11
Preparations for starting .....	10, 11
Radiator shutter .....	10
Starting the engine .....	12, 13
Stopping the engine .....	13
Operating a distillate-gasoline engine on gasoline .....	14
Operation of a gasoline engine .....	8, 9
Fuel system .....	8
Starting the engine .....	8, 9
Stopping the engine .....	9
Operating a kerosene engine .....	14
Tractor specifications .....	Inside back cover

## TRACTOR MAINTENANCE

Adjustment of rear wheel treads .....	40
Air cleaner .....	20
Belt pulley (special) .....	39
Brakes .....	37
Carburetor .....	30
Clutch .....	36
Cooling system .....	33
Drawbar and hitch .....	38
Engine service operations (minor) .....	36
Fan .....	34
Fuel strainer .....	32
Magneto .....	27 to 29
Oil filter .....	21
Periodic inspections .....	19
Pneumatic tires .....	44
Power take-off (special) .....	39
Spark plugs and cables .....	22
Storing the tractor .....	48
Suggestions for checking trouble .....	47
Valves (adjusting clearance) .....	35
Wiring .....	22

**NOTE:** The instructions in this manual cover the operation of tractors on all types of fuel, except where otherwise specified.

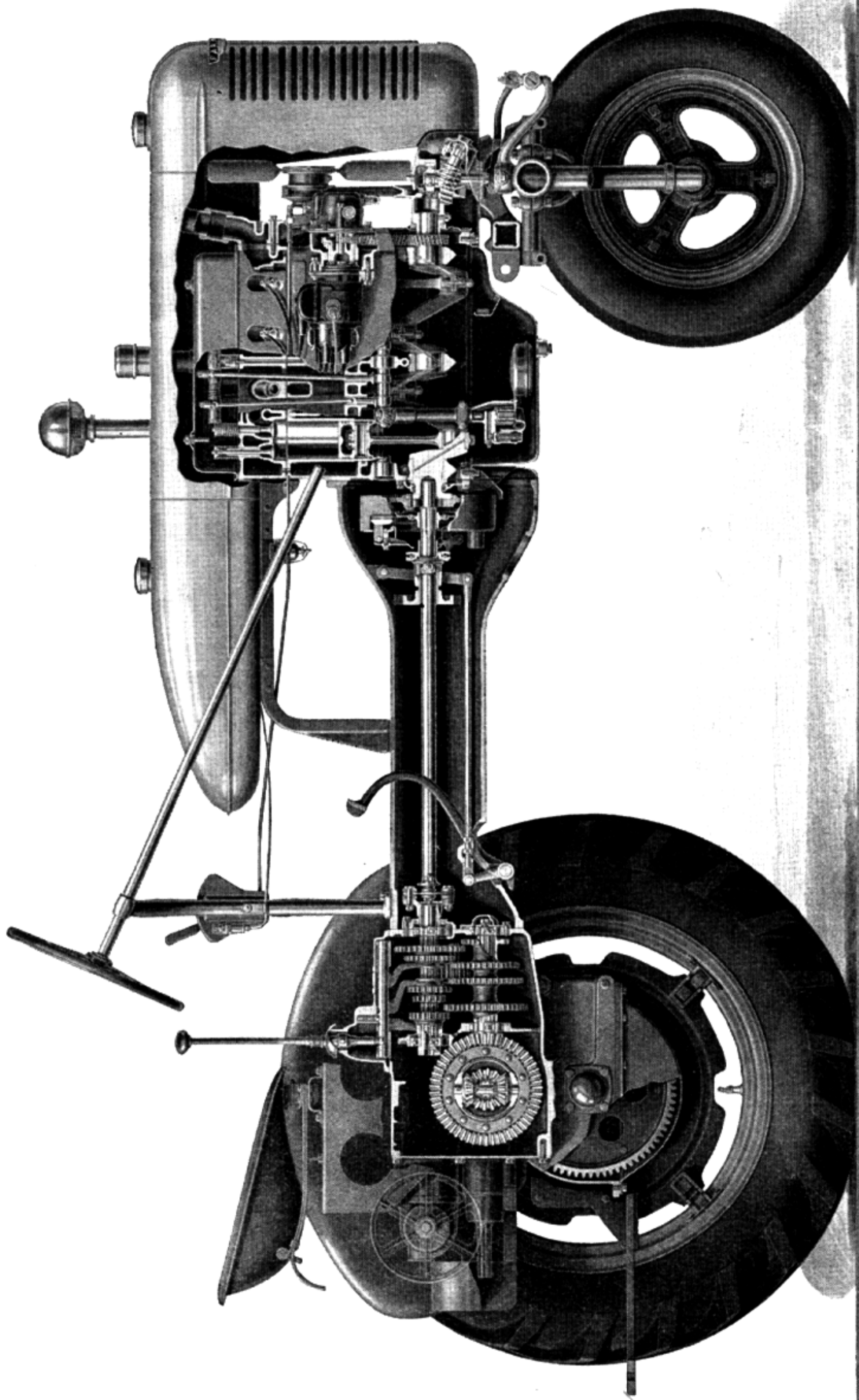

Cut-away view of the Farmall-A tractor showing the internal working parts. The belt pulley and power take-off shown in this illustration are special features.

# BEFORE STARTING A NEW TRACTOR

*Make a complete inspection of the tractor for any shortages or damage which may have occurred while being shipped.*

## Lubrication

(1) Lubricate entire tractor, using the "Lubrication Chart" (center of Manual) as a guide.

(2) Check the oil levels of engine crankcase, air cleaner, transmission case and steering gear case to see that they are filled to the correct levels with the proper grades of oil for the prevailing temperature (*refer to specifications of lubricants on page 25*).

(3) Tractors shipped to destinations in the United States of America, Canada, and Mexico are filled with oil in all parts before leaving the factory. However, lubricant compartment should be checked for proper levels *as outlined in item 2 above*.

### TRACTORS PACKED FOR EXPORT

All oil is drained from the engine crankcase, air cleaner, and all gear cases on tractors packed for export.

(4) Engines shipped to destinations in the United States of America, Canada and Mexico are filled with a light engine oil before leaving the factory. For further information, see "Lubrication Chart."

(5) Before starting a new engine, remove the spark plugs and put about one teaspoonful of crankcase oil into each cylinder; replace the spark plugs and crank the engine to distribute the oil over the cylinder walls. This assures positive lubrication of the cylinders and pistons immediately after starting and eliminates the possibility of scoring. Procedure outlined is only necessary for a new engine,

or an engine that has been idle for a long time.

## Pneumatic Tires

(1) Before moving tractor, check air pressure in pneumatic tires and inflate or deflate to correct pressures as shown in chart *on page 44*.

## Engine Cooling System

(Water capacity is approximately 3¼ U.S. gallons.)

(1) Be sure the drain plug (on left hand side of crankcase near radiator) is closed (*see Illust. 25*).

(2) Fill the radiator to a level slightly below the bottom of the filler neck. Filling the radiator to this level will allow for expansion of the coolant under normal operating conditions. Use clean water. Soft or rain water is recommended as it does not contain alkali which forms scale and eventually clogs the passages.

(3) For further information see "Cooling System," page 33. If the tractor is to be operated in freezing temperatures (thirty-two degrees Fahrenheit or lower) *refer to "Cold Weather Operations" on Page 18*.

## Fuel System

(1) Use the fuel for which the tractor engine is equipped.

(2) During the first one hundred hours of operation, mix one pint of engine oil with every five U.S. gallons of fuel.

# INSTRUMENTS AND CONTROLS

(See *Illusts. 1, 6 and 8*)

## Clutch Pedal

This pedal, when depressed all the way, disengages the engine from the transmission.

## Brake Pedals

These pedals should be used to stop the tractor, to hold the tractor in a stationary position, or to assist in making sharp turns as outlined below:

*To stop the tractor* the pedals should be latched together so both brakes will operate simultaneously.

*To hold the tractor in a stationary position* latch the pedals together, depress, and lock them in this depressed position by using the brake pedal lock.

*To assist in making a sharp turn* the pedals must be operated individually, depressing the pedal on the side toward which the turn is to be made.

## Brake Pedal Latch—(See *Illust. 11*)

This latch is used to latch both brake pedals together causing the brakes to operate simultaneously.

## Brake Pedal Lock

The brake pedal lock is used to lock the brake pedals in the depressed position which prevents the tractor from moving.

## Gearshift Lever

This lever is used to select the various gear ratios provided in the transmission. There are four (4) forward speeds and one (1) reverse speed (*see Illust. 10*).

## Manifold Heat Control Lever

This control lever is used on the distillate-gasoline engine and for normal operation should be set in the top notch (Hot) position. If the distillate-gasoline engine is to be operated on gasoline, the control lever should be set in the bottom notch (Cold) position, and the manifold shield should be removed. (For complete instructions refer to pages 11 and 14.)

## Magneto Grounding Switch Button

This button, when pushed all the way in, will ground the magneto and stop the engine. Pull out this button when starting the engine.

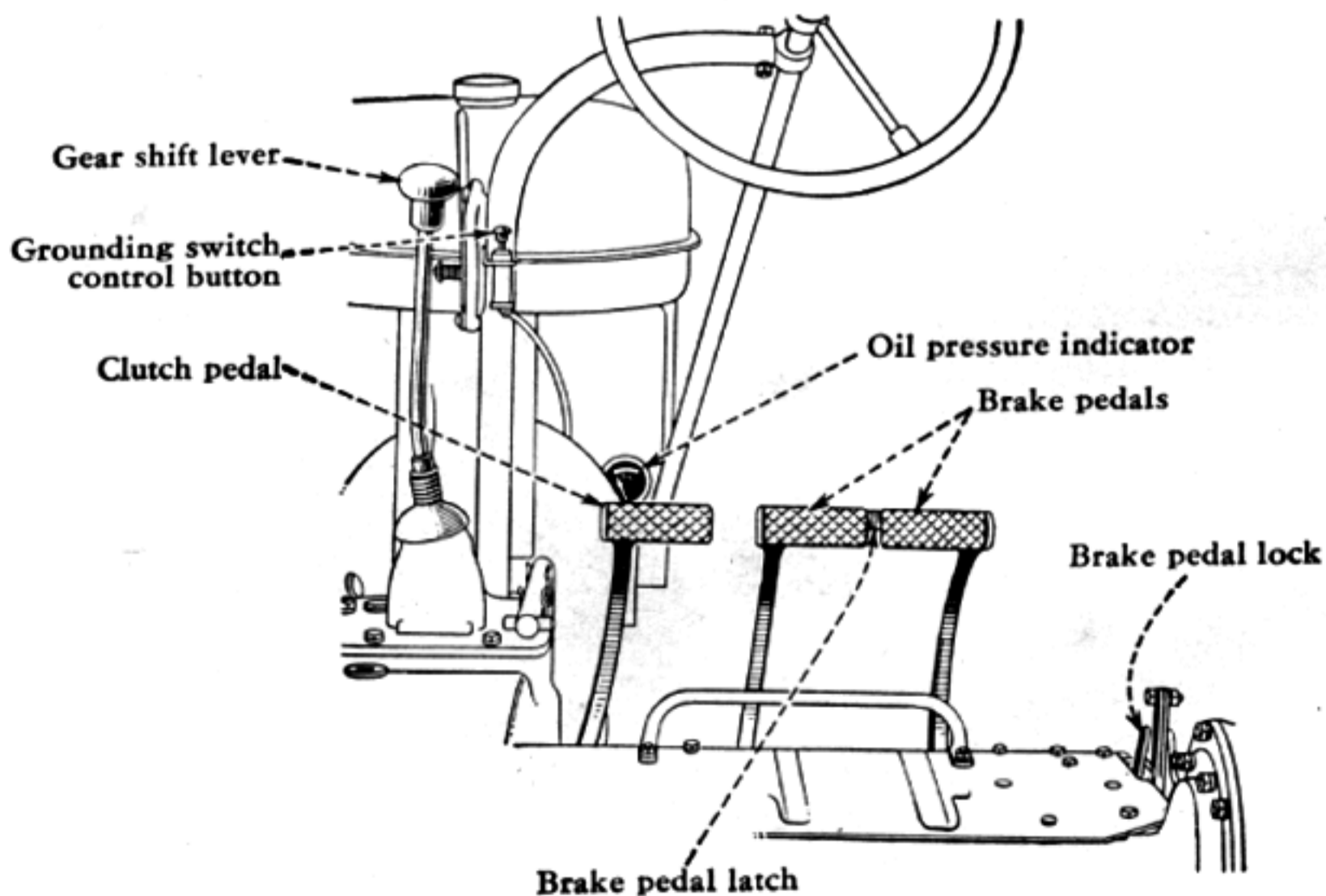

**Illust. 1**

Location of Controls.

## INSTRUMENTS AND CONTROLS—Continued

### Governor Speed Control Lever

This lever controls the speed of the engine and when set in a given position, will maintain a uniform engine speed even though the engine load may vary.

### Radiator Shutter Control Crank

The control crank opens and closes the radiator shutter controlling the engine temperature. Turn the crank counter-clockwise to close the shutter and clockwise to open it.

(NOTE: The gasoline tractors are not regularly equipped with this feature.)

### Oil Pressure Indicator

This gauge indicates the pressure at which the oil is circulating through the engine. The indicator needle should be in the white area when the engine is running

(as shown in *Illust. 4*). If it is not in the white area, stop the engine immediately and investigate the cause of the oil pressure failure.

### Choke Lever (on carburetor)

This lever, which is on the carburetor (see *Illusts. 22 and 23*), cuts off the air supply, thereby enriching the fuel mixture for starting the engine when it is moved toward the rear (closed position). Always move the choke lever all the way forward (open position) as the engine warms up.

### Heat Indicator—(See *Illust. 7*)

This gauge indicates the temperature of the liquid in the cooling system.

(NOTE: The gasoline tractors are not regularly equipped with this feature.)

## HOW TO PREPARE YOUR TRACTOR FOR EACH DAY'S WORK

### Fuel System

Fill the fuel tank at the end of each day's run. This will force out any moisture-laden air and prevent condensation. The capacity of the fuel tank is 10 U. S. gallons. Tractors designed for distillate-gasoline operation have an auxiliary gasoline tank (capacity 1 U. S. gallon) which is used only for starting and warming up the engine. If a distillate-gasoline engine is to be operated on gasoline only, the large fuel tank is used for gasoline and the small tank can be shut off or used as an auxiliary tank.

NOTE: Refer to "Operating Precautions" on page 6 regarding the selection of fuels; also safety measures when filling fuel tanks.

### Cooling System

Remove the radiator cap and check to see

that the water comes up to a point slightly below the bottom of the filler neck. Be sure to replace the radiator cap.

### Lubrication

(1) Change the oil in the air cleaner oil cup.

(2) Be sure the oil in the crankcase pan is up to the level of the upper test cock. When your tractor is being operated on distillate fuel, open the lower test cock in the crankcase pan and allow the oil to drain to this level. Close the lower test cock and open the upper cock. Add new oil until it appears at this level and then close cock.

(3) Refer to the Lubrication Chart (center of Manual) for complete lubrication requirements.

## OPERATING PRECAUTIONS



A-4084A

Illust. 2

Showing Proper Method of Filling the Fuel Tank.

Provision is made in the design of this tractor so that it may be equipped with either a distillate-gasoline, kerosene or gasoline-burning engine. Before attempting to use a fuel for which your tractor is not designed, see your International Harvester dealer or the nearest IHC Branch for full details.

To obtain best results, use the fuel for which the tractor is equipped, follow Operating Instructions given for that fuel and observe the following precautions:

(1) Distillate fuels should conform to International Harvester Company specifications (see your International Harvester dealer).

(2) Distillate-burning tractors should not have the shut-off valve under the auxiliary tank and the one under the main fuel tank open or even partially open at the same

time, as this will permit the distillate to mix with the gasoline, making the engine hard to start.

(3) **SAFETY FIRST!** Never fill the fuel tank when lamps are lighted, when near an open flame, or when the engine is running. When pouring in fuel, keep the funnel and container in contact with the metal of the fuel tank (*see Illust. 2*) to avoid the possibility of an electric spark igniting the gas. Do not light matches near gasoline as the air within a radius of several feet is permeated with a highly explosive vapor.

(4) Both fuel tanks have air vents in the filler caps. These vents should be kept open at all times to assure proper flow of the fuels (*see Illust. 3*).

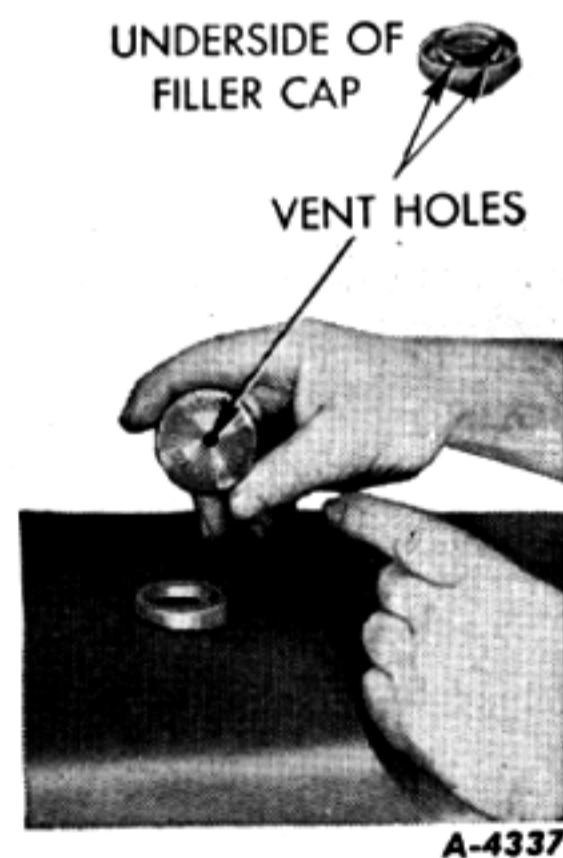

A-4337

Illust. 3

Vent Holes in Filler Cap.



## OPERATING PRECAUTIONS—Continued

(5) **CAUTION!** When cranking the engine, the operator should stand in a position that will eliminate any possibility of being struck by the starting crank if there is a reversal of the direction of the engine. Crank the engine by using quick up-strokes; do not spin it.

(6) To start an engine that has been stopped while operating on distillate or kerosene and has cooled off, close the main fuel shut-off valve, drain the distillate from the carburetor fuel bowl and fuel strainer bowl; then proceed in accordance with "Starting the Engine" instructions shown on page 12.

(7) Never operate the engine at more than the regular governed speed. Excessive speeds are harmful.

(8) Do not "ride" the clutch or brake pedals, as this will result in excessive wear on the linings.

(9) Pulled loads should be attached to the drawbar. Hitching chains or ropes to axles or other parts of the tractor is dangerous and may cause permanent damage to the tractor.

(10) Do not pour cold water into the radiator if the engine is very hot unless conditions make it absolutely necessary. Under such conditions, start the engine and let it idle while slowly pouring water into the radiator.

(11) The governor speed control lever should be adjusted to suit the load to be handled.

Do not run the engine under load until it is thoroughly warmed up and heat indicator pointer is on the high side of the "Run" portion (*see Illust. 7*) for distillate or kerosene operation and on the low side for gasoline operation.



Illust. 4  
Oil Pressure Indicator.

(12) Immediately after engine starts, check oil pressure indicator (*see Illust. 4*) to see if it is registering pressure. If it is not, stop engine and inspect the oil system to find the cause of failure. If you are unable to find cause, be sure to consult your International Harvester dealer before operating the engine.

(13) Be sure to replace lubricating oil filter elements and clean air cleaner at regular intervals.

### Power Take-Off

If your tractor is equipped with a power take-off be sure to stop the power take-off before dismounting from the tractor. Also, put the gearshift lever in neutral position.

# OPERATING GASOLINE ENGINE

## Preparations for Starting

### Governor Control Lever

The governor control lever enables you to adjust the speed of the engine to the load that is to be handled. After you have selected the desired engine speed, the governor will automatically maintain this engine speed under variable loads. Retarding of the governor control lever will decrease the load which the tractor can handle.

The rated or maximum full load governed speed is 1400 rpm; maximum idle speed is approximately 1540 rpm; minimum speed (hand throttle) is 500 to 550 rpm. Never operate the engine at more than the regular governed speed. Excessive speeds are harmful.

### Governor

The governor is set at the factory and should require no adjustment. Consult your International Harvester dealer if the governor does not function properly.

### Fuel System

Check the fuel tank to make sure it is full; also see that the shut-off valve on the fuel strainer under the gasoline tank is open.

### Starting the Engine

Be sure the magneto grounding switch control button is pulled out so that magneto is not grounded (*see Illust. 1*); Place the gearshift lever in neutral position (*see Illust. 10*) and advance the governor control lever about one third (push forward to advance).

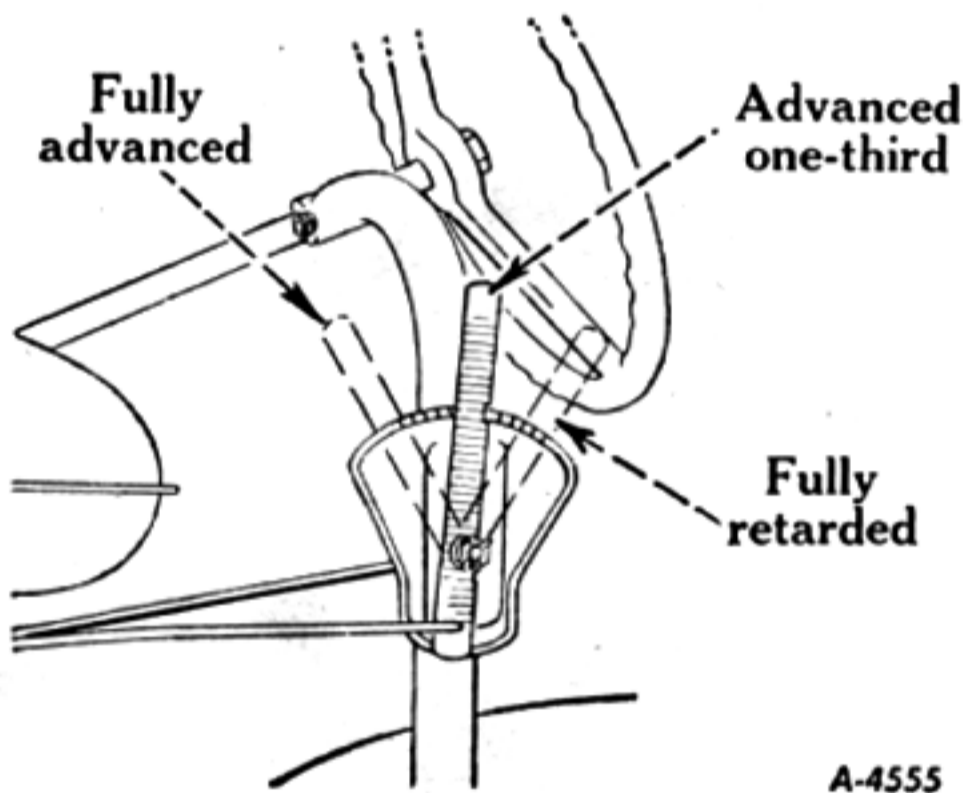

Illust. 5

View Showing Various Positions of the Governor Control Lever.

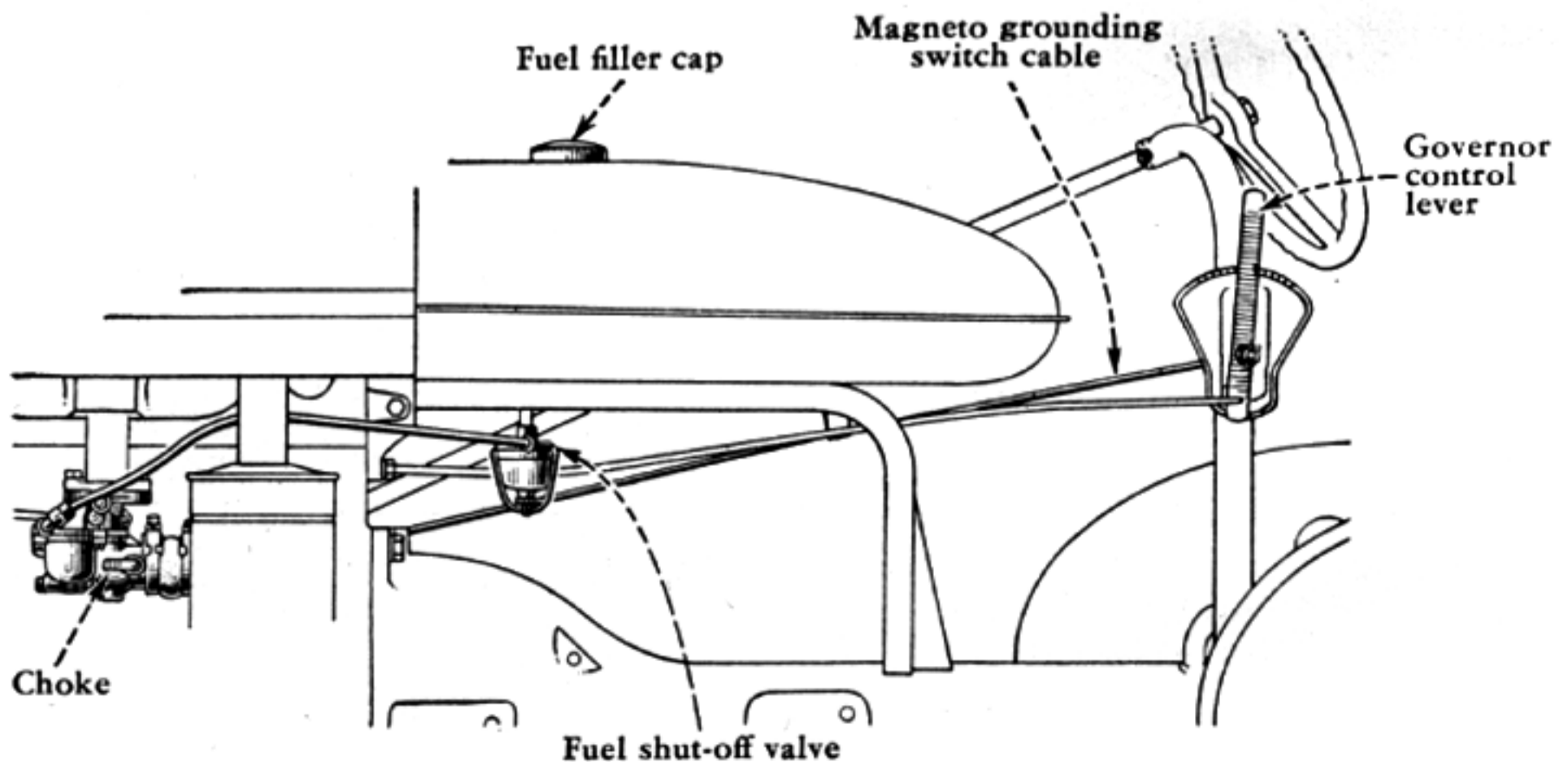

Illust. 6—Fuel System and Controls.

## OPERATING GASOLINE ENGINE—Continued

### Starting the Engine—Continued

Pull choke lever on carburetor (*see Illusts. 6 and 22*) about half-way down. Avoid over-choking as excessive use of the choke will flood the engine, making it hard to start. For best results, follow the procedure outlined below.

### During Warm Weather or with Engine Warm

Set the choke lever in half-open position and crank the engine, using quick up-strokes until engine starts.

### During Cold Weather or with Engine Cold

Tractors designed for gasoline operation are not regularly equipped with a radiator shutter, but this feature can be supplied. If your tractor is so equipped, however, close the shutter when starting in cold weather and regulate it as required to hold the needle of the heat indicator in the low side of the "RUN" range.

Close choke completely by pulling lever down as far as it will go—then crank engine with quick up-strokes as follows:

6 to 8 lifts of the crank at temperatures zero to ten degrees Fahrenheit.

4 to 5 lifts of the crank at temperatures ten to twenty degrees Fahrenheit.

2 to 3 lifts of the crank at temperatures twenty to thirty degrees Fahrenheit.

Now, open the choke half-way and crank with quick up-strokes until engine starts.

**CAUTION!** When cranking the engine, operator should stand in a position that will eliminate any possibility of being struck by the starting crank if there is a reversal of the direction of the engine.

Crank the engine by using quick up-strokes; do not spin it.

The use of the choke for starting will vary, depending on temperature and altitude. The preceding instructions offer approximate requirements which may be altered to suit local conditions.

### Electric Starter Attachment—Special

If the tractor has an Electric Starter Attachment, pull choke rod (located on dash) half-way out, disengage the clutch by pressing down on clutch pedal, and step on the starter button. Slowly release the clutch pedal after engine has started.

### After Engine Starts

As soon as the engine starts the choke should be adjusted to a point where the engine runs without missing, and as the engine warms up, the choke should be gradually opened all the way. Do not use the choke to enrich the fuel mixture except when starting the engine. Never operate the engine with the choke partly closed.

Immediately after engine starts, check the oil pressure indicator on dash (*see Illust. 4*) to see if it is registering pressure. If it is not, stop engine and inspect the oil system to find the cause of failure. If unable to find cause, consult an International Harvester Company dealer before operating engine.

### Stopping the Engine

Retard the governor control lever by pulling it all the way back and short-circuit the magneto by pushing the grounding switch control button all the way in. It is advisable to close gasoline shut-off valve if engine is to be stopped for any length of time.

# OPERATION OF A DISTILLATE-GASOLINE ENGINE ON DISTILLATE

## Preparations for Starting

### Radiator Shutter

Tractors designed for operation on distillate are regularly equipped with a radiator shutter to assist in warming up a cold engine quickly and to maintain engine at the most efficient operating temperature.

Distillate fuels are heavier than gasoline and therefore require more heat for proper vaporization. Before starting a distillate-gasoline engine, close the radiator shutter completely by turning the radiator shutter control crank (*see Illust. 8*) all the way to the left (counterclockwise). (After the engine has been started, allow it to run with the radiator shutter closed until the pointer on the heat indicator is on the high side of the "Run" section; then regulate the shutter enough to keep

the pointer on the heat indicator in this position, *see Illust. 7*.) The adjustment of the shutter will vary, depending on the load the tractor is handling, length of idling periods, atmospheric temperatures, and the kind and quality of fuel that is being used.

**IMPORTANT!** Before filling radiator in freezing weather, close the radiator shutter, start engine; then put in water immediately. This prevents water from freezing during warming-up period. After engine has warmed up adjust radiator shutter to maintain operating temperature of engine on the high side of the "Run" portion on heat indicator (*see Illust. 7*).

### Fuel System

Check the fuel and auxiliary gasoline tanks to make sure they are full. Open the gasoline valve and be sure the shut-off valve for the main fuel tank is closed. (This shut-off valve should not be opened until the engine has been running on gasoline long enough to be thoroughly warmed up.)

**NOTE:** Do not have the shut-off valve under the auxiliary tank and the one under the main fuel tank open at the same time as this will permit the distillate fuel to mix with the gasoline, making the engine hard to start.



Illust. 7

The engine has reached the most efficient operating temperature when the needle on the heat indicator is approximately on the high side of the "Run" section.

# OPERATING DISTILLATE-GASOLINE ENGINE ON DISTILLATE

## —Continued

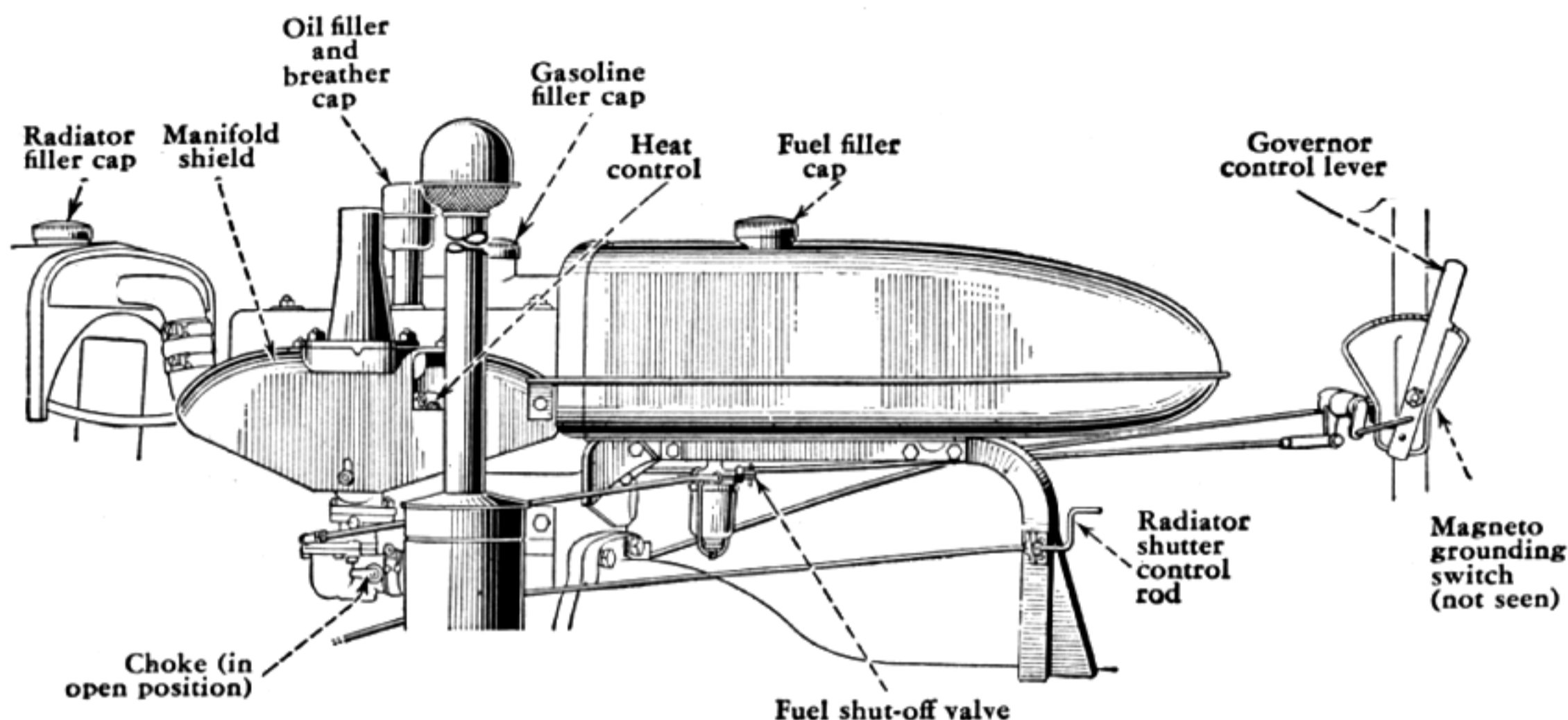

Illust. 8

Fuel System and Controls.

### Manifold Heat Control (See *Illust. 8A*)

The distillate-gasoline engine manifold is designed so that the hot exhaust gases pass around the intake manifold and heat the incoming fuel mixture, resulting in maximum efficiency under all normal operating conditions.

The manifold heat control valve has three adjustment positions: (1) Top notch, or "Hot" position, (2) Center notch, or "Intermediate" position, (3) Bottom notch, or "Cold" position.

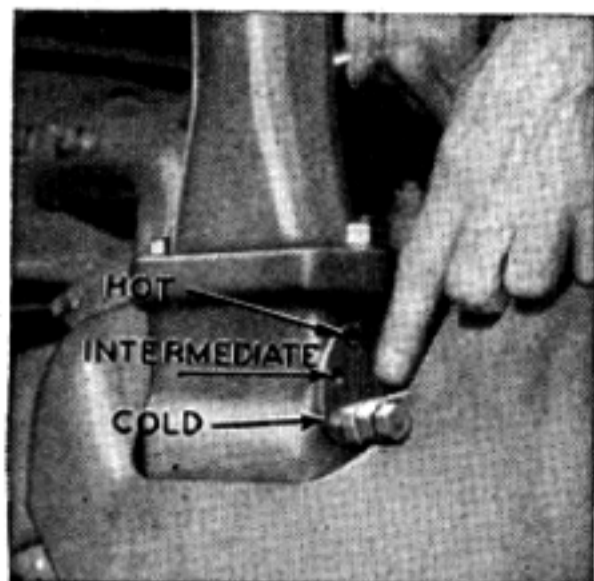

Illust. 8A

With these adjustments the heat of the manifold can be regulated to suit the various operating conditions, which are governed by the prevailing air temperature, load the engine is handling, and kind and quality of fuel that is being used.

When operating engine on distillate, the heat control valve should be set in the top notch or "Hot" position. To do this, loosen the nut on the heat control adjusting lever and raise the lever to the top notch. Always keep the valve in this position except when the prevailing temperature is very high, or when the engine is operating with a constant heavy load. In such cases, use either the "Intermediate" or "Cold" positions.

The manifold should be kept hot at all times to vaporize the heavy fuels properly and to avoid dilution of the crankcase lubricating oil.

# OPERATION OF A DISTILLATE-GASOLINE ENGINE ON DISTILLATE

## —Continued

### Starting the Engine

Be sure the magneto grounding switch button is pulled out so that magneto is not grounded (*see Illust. 1*); also see that the shut-off valve under the gasoline tank is open and the fuel shut-off valve under the main fuel tank is closed. Be sure there is no distillate fuel in the carburetor and fuel strainer.

**CAUTION!** Never have both valves open or partially open at the same time as distillate will mix with the gasoline, making it unsatisfactory for starting.

Place the gearshift lever in neutral position (*see Illust. 10*) and advance the governor control lever about one third (push forward to advance).

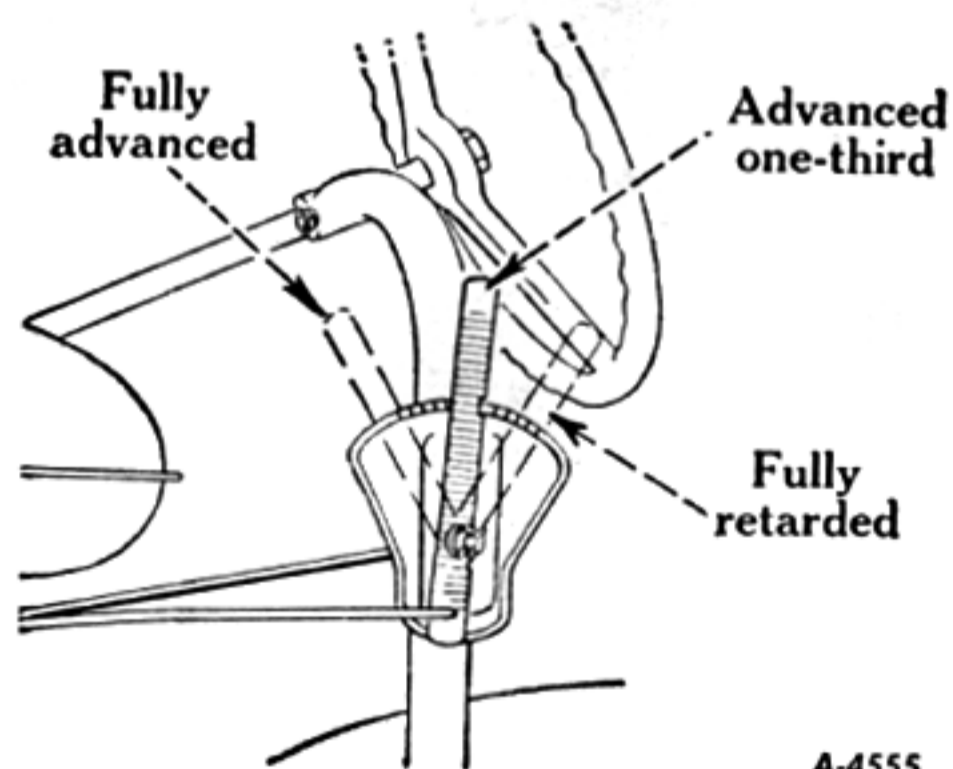

Illust. 9

View Showing Various Positions of the Governor Control Lever.

Pull choke lever on carburetor (*see Illusts. 8 and 23*) about half-way down. Avoid overchoking as excessive use of the choke will flood the engine, making it hard to start. For best results, follow the procedure outlined in the succeeding paragraphs.

#### During Warm Weather, or with Engine Warm

Set the choke lever on the carburetor in half-open position (half-way back toward flywheel) and crank engine, using quick up-strokes until engine starts.

#### During Cold Weather, or with Engine Cold

Close choke completely by pulling lever down as far as it will go and crank engine with quick up-strokes as follows:

6 to 8 lifts of the crank at temperatures zero to ten degrees Fahrenheit.

4 to 5 lifts of the crank at temperatures ten to twenty degrees Fahrenheit.

2 to 3 lifts of the crank at temperatures twenty to thirty degrees Fahrenheit.

Now, open the choke half-way and crank engine with quick up-strokes until the engine starts.

**CAUTION!** When cranking the engine, operator should stand in a position that will eliminate any possibility of being struck by the starting crank if there is a reversal of the direction of the engine. Crank the engine by using quick up-strokes; do not spin it.

The use of the choke for starting will vary depending on temperature and altitude. The preceding instructions offer approximate requirements, which may be altered to suit local conditions.

## OPERATING DISTILLATE-GASOLINE ENGINE ON DISTILLATE —Continued

### Electric Starter Attachment—Special

If the tractor has an electric starter attachment, pull choke rod (located on dash) half-way out, disengage the clutch by pressing down on clutch pedal, and step on the starter button. Slowly release the clutch pedal after engine has started.

### After Engine Starts

As soon as the engine starts, the choke should be adjusted to a point where the engine runs without missing, and as the engine warms up, the choke should be gradually opened all the way (*see Illusts. 8 and 23*). Do not use the choke to enrich the fuel mixture except when starting the engine.

Do not run the engine under load until it is thoroughly warmed up (when heat indicator pointer is on the high side of the "Run" portion, *see Illust. 7*).

Immediately after engine starts, check oil pressure indicator on dash (*see Illust. 4*) to see if it is registering pressure. If it is not, stop engine and inspect the oil system to find the cause of failure. If unable to find cause, be sure to consult your International Harvester dealer before operating engine.

To start an engine that has been stopped while operating on distillate and has cooled off, close the main fuel shut-off

valve, drain the distillate from the carburetor fuel bowl and fuel strainer bowl; then proceed in accordance with "Starting the Engine" instructions *shown on page 12*.

### After Engine is Warmed Up

After the engine has run a while and the needle on the heat indicator is on the high side of the "Run" section, change over to operate on distillate by tightly closing the gasoline shut-off valve and quickly opening the shut-off valve under the main fuel tank. Then regulate the radiator shutter so that the needle will remain in this position (*see Illust. 7*).

### Stopping the Engine

Close the distillate shut-off valve and open the gasoline shut-off valve. Operate the engine two or three minutes with the governor control lever one-half open to empty the fuel lines of distillate and fill them with gasoline. This will assure having gasoline in fuel bowl for starting again. Retard the governor control lever by pulling it all the way back. Short-circuit the magneto by pushing the grounding switch control button all the way in.

After the engine has stopped, it is a good policy to close the gasoline shut-off valve.

## INSTRUCTIONS FOR OPERATING A DISTILLATE-GASOLINE ENGINE ON GASOLINE

**NOTE:** To operate a distillate-gasoline engine on gasoline, follow the same operating instructions as for distillate operation, *on pages 10 to 13*, except as outlined below:

### Fuel System

The 10 U. S. gallon fuel tank is used for gasoline and the small tank may be used as an auxiliary tank.

### Radiator Shutter

Close the radiator shutter when starting the engine in cold weather, and as the engine warms up, regulate the shutter to maintain the proper operating temperature.

### Manifold Heat Control

Set the heat control valve in "Cold"

position except when operating under light load, or in extremely cold weather; in which case, the valve should be set in "Intermediate" position.

### Manifold Shield

The manifold shield should be removed except when operating in extremely cold weather.

### To Stop the Engine

Retard the governor control lever by pulling it all the way back (*see Illust. 9*) and short-circuit the magneto by pushing the grounding switch control button all the way in.

It is advisable to close the fuel shut-off valve if engine is to be stopped for any length of time.

## INSTRUCTIONS FOR OPERATING A KEROSENE ENGINE

If your tractor is equipped with a kerosene-burning engine, follow the same operating instructions as outlined for distillate operation.

If this kerosene engine is to be operated on gasoline, the same instructions as for operating a distillate engine on gasoline will apply.

---



# DRIVING THE TRACTOR

## SAFETY FIRST

Do not make short turns at high speeds.

Always lock brake pedals together when traveling in high gear.

Read and observe "Cautions" shown on page 17.

After tractor is in motion, extreme care should be taken to prevent accidents and personal injuries.

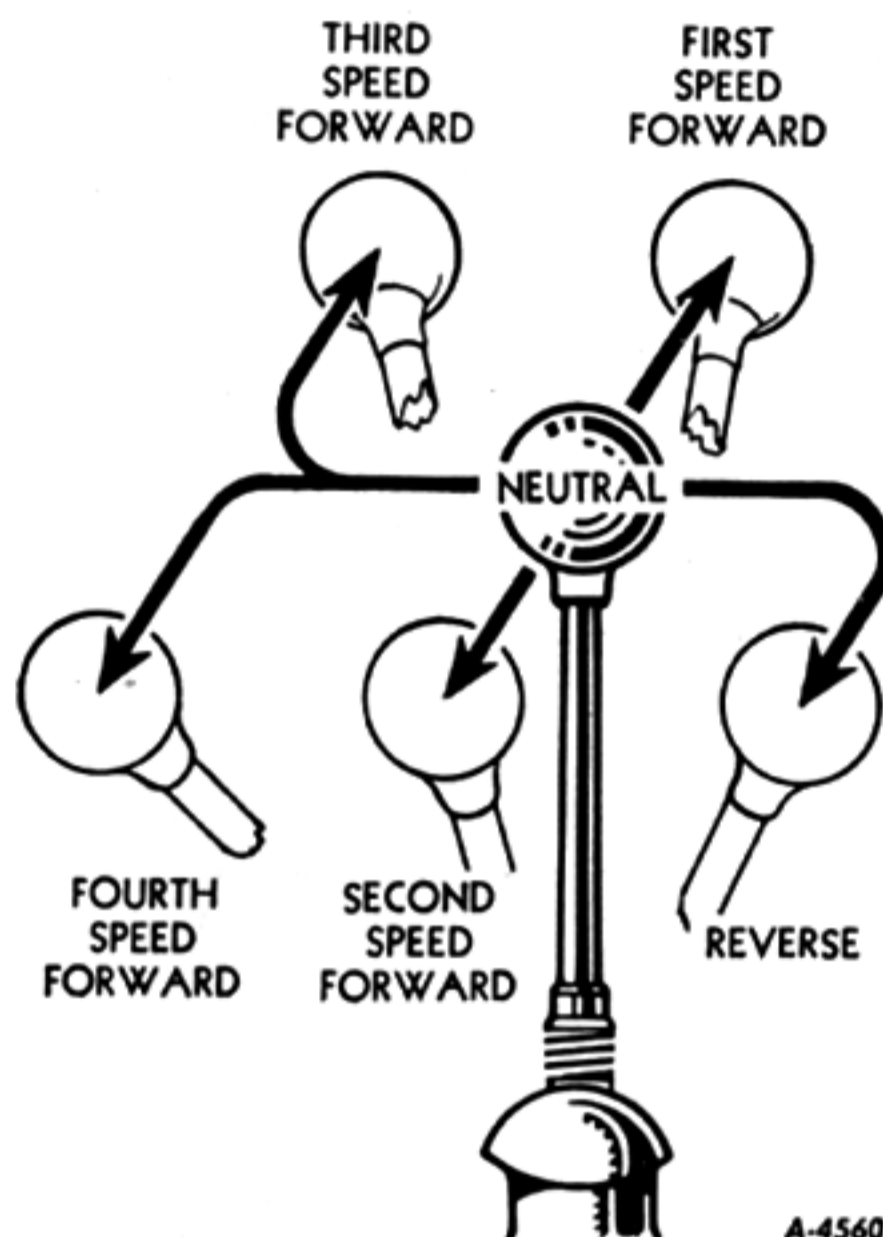

Illust. 10—Gear Shifting Positions.

### To Start Tractor

The governor control lever should be advanced to a position where the engine operates best for the load to be handled. Disengage the clutch by placing the left foot on clutch pedal and pressing down firmly. Keep the clutch pedal in this position and move the gearshift lever to the desired speed. The clutch must always be disengaged while shifting gears. When starting the tractor always engage the clutch gradually by gently releasing pressure on clutch pedal; if this is done, engine will pick up the load slowly. This is particularly necessary when tractor

is going up a steep hill, climbing out of ditches, or when it is hitched to a heavy or difficult load.

Do not drive the tractor with foot resting on clutch pedal, as it will cause undue wear on clutch facings and clutch release bearing.

Do not operate a new tractor immediately on a full load; run the tractor light for a reasonable length of time. Do not overload the tractor at any time.

### Gear Shifting (Four Speeds Forward)

Always disengage clutch before making a gear shift.

## DRIVING THE TRACTOR—Continued

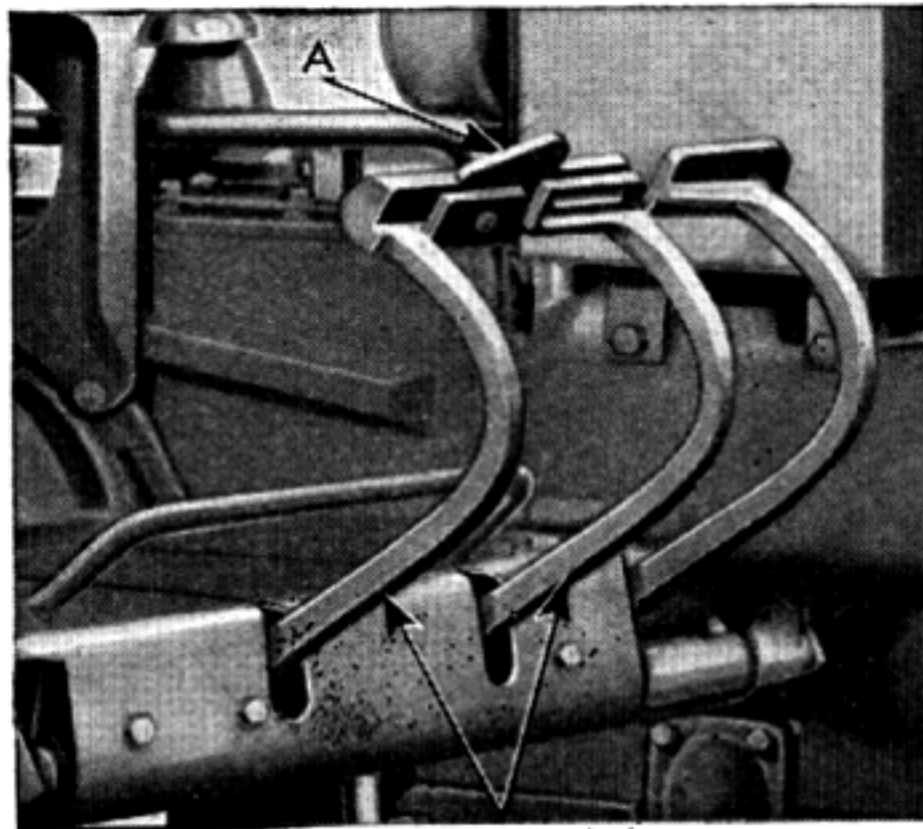

Brake pedals A-4666

Illust. 11

Rear View of Brake Pedals Locked Together.

### Steering

The tractor is steered in the conventional manner by means of the steering wheel; however, to make a sharp or pivot turn, press either the right or left brake pedal, depending on the direction in which the turn is to be made. The brake pedals must be unlatched so they can be operated individually.

### Latch for Locking Brake Pedals

Together (See *Illust. 11*)

**CAUTION!** The brake pedals should always be latched together when driving the tractor in high gear.

To latch the pedals together, engage the latch "A" (located in back of right hand pedal) in the slot in back of the left pedal. When brake pedals are not latched together the latch should rest in the slot in back of the right brake pedal.

### Brake Pedal Lock (See *Illust. 1*)

To lock the brakes, drop the pedal latch

into the slot behind the pedals; press down the right brake pedal and engage the brake pedal lock.

### Locking Brakes

To lock the brakes, first lock the brake pedals together with latch as previously described. Then lift the lock and let fall into engaged position. Now press down on the foot pedals. To disengage the lock, press down on the foot pedals, lift the lock and let it fall into the disengaged position.

### To Stop Tractor

Disengage clutch by pressing down firmly on clutch pedal and move the gearshift lever to neutral position. Use the brakes if necessary.

**SAFETY FIRST!** Stop the power take-off before dismounting from the tractor. Also put the gearshift lever in neutral position.



# Accidents can be prevented with your help

## Rules for safe tractor operation

(Prepared by the Farm Safety Committee of the Farm Equipment Institute  
and approved by the National Safety Council, Inc.)

1. Be sure the gear shift lever is in neutral before cranking the engine.
2. Always engage the clutch gently, especially when going up a hill or pulling out of a ditch.
3. When driving on highways, or to and from fields, be sure that both wheels are braked simultaneously when making an emergency stop.
4. Always ride on seat or stand on platform of tractor. Never ride on drawbar of tractor or drawn implement.
5. When tractor is hitched to a stump or heavy load, always hitch to drawbar and never take up the slack of chain with a jerk.
6. Be extra careful when working on hillsides. Watch out for holes or ditches into which a wheel may drop and cause tractor to overturn.
7. Always keep tractor in gear when going down steep hills or grades.
8. Always drive tractor at speeds slow enough to insure safety, especially over rough ground or near ditches.
9. Reduce speed before making a turn or applying brakes. The hazard of overturning the tractor increases four times when speed is doubled.
10. Always stop power take-off before dismounting from tractor.
11. Never dismount from tractor when it is in motion. Wait until it stops.
12. Never permit persons other than the driver to ride on tractor when it is in operation.
13. Never stand between tractor and drawn implement when hitching. Use an iron hook to handle drawbar.
14. Do not put on or remove belt from belt pulley while the pulley is in motion.
15. Should motor overheat, be careful when refilling radiator.
16. Never refuel tractor while motor is running or extremely hot.
17. When tractor is attached to a power implement be sure that all power line shielding is in place.

*Remember a CAREFUL OPERATOR always is the  
BEST INSURANCE against an accident.*

# COLD WEATHER OPERATION

If the tractor is to be operated in temperatures of thirty-two degrees Fahrenheit or lower, observe the following precautions:

## Fuel System

Use only a high-test winter-grade gasoline for starting, and keep your supply in a closed container so the more volatile portion does not evaporate.

Fill the fuel tank at the end of the day's run to prevent moisture from collecting in the tank.

## Lubrication

Be sure to use the correct grade of lubricant in the engine crankcase, air cleaner, magneto impulse coupling, transmission, differential and steering gear case *as specified on page 25*.

## Cooling System

When the temperature is likely to be thirty-two degrees Fahrenheit or lower, there is danger of the water freezing in the cooling system. To overcome this, either drain the water from the cooling system at the end of each run, or use one of the recommended antifreeze solutions.

## To Drain the System

(1) Remove the radiator drain plug on lower left-hand side of engine (*see Illust. 25*).

(2) See that drain is not plugged and that water drains completely.

**IMPORTANT!** Before filling radiator in freezing weather, either close radiator shutter (if tractor is so equipped) or cover entire radiator, start engine; then put in water immediately. This prevents water from freezing during warming-up period. When the engine has warmed up, uncover

the radiator or adjust radiator shutter to maintain operating temperature of engine on the high side of the "Run" portion on heat indicator (*see Illust. 7*).

## Antifreeze Solutions

The following table shows the quantity of antifreeze to be added per gallon of water. To determine the total quantity necessary, multiply the capacity of the cooling system ( $3\frac{1}{4}$  U. S. gallons) by the number of pints per gallon required at the prevailing temperature.

Freezing Point (Fahrenheit)	Pints required per Gal.		
	Ethylene Glycol	Distilled Glycerine	Denatured Alcohol
10°	2	3	2½
0°	2½	3½	3
-10°	3	3½	3½
-20°	3½	4	4
-30°	4	5	5
-40°	4½	—	5½
-50°	4½	—	6
-60°	5	—	6½
-70°	5	—	—

The use of alcohol as an antifreeze is not recommended because denatured alcohol boils at 173°F. If, however, it is necessary to use alcohol it should be checked frequently to make certain that you have adequate protection for the prevailing temperature.

**CAUTION!** Do not mix antifreeze solutions.

Do not under any circumstances use any of the following in the cooling water as an antifreeze:

Honey, salt, kerosene, fuel oil, glucose or sugar, calcium chloride, or any alkaline solution.

# PERIODIC INSPECTIONS

To keep your tractor performing efficiently it is advisable to systematically inspect it at intervals as outlined below.

## After 10 Hours of Operation

Point of Inspection	Remarks
*Air cleaner cap.....	Remove dirt or chaff ( <i>refer to page 20</i> ).
Lubrication Points .....	<i>See Lubrication Chart.</i>

## After 60 Hours of Operation

Point of Inspection	Remarks
*Air cleaner, complete.....	Remove and clean ( <i>refer to page 20</i> ).
Flexible rubber connection between air cleaner and carburetor.....	Inspect for loose fit or damage.
Fan belt.....	Check tension; replace when necessary ( <i>refer to page 34</i> ).
Radiator fins .....	Clean spaces ( <i>refer to page 33</i> ).
Lubrication Points .....	<i>See Lubrication Chart.</i>

## After 120 Hours of Operation

Point of Inspection	Remarks
Crankcase breather cap.....	Remove and clean.
Lubricating oil filter.....	Replace filter element ( <i>refer to page 21</i> ).
Engine crankcase.....	Drain and change oil.
Lubrication Points .....	<i>See Lubrication Chart.</i>

## After 250 Hours of Operation

Point of Inspection	Remarks
Fuel strainer and sediment bowl.....	Take apart and clean ( <i>refer to page 32</i> ).
Spark plugs.....	Remove and clean; check gap ( <i>refer to page 22</i> ).
Magneto breaker points and chamber.....	Clean chamber and check gap ( <i>refer to page 27</i> ).

## After 400 Hours of Operation

Point of Inspection	Remarks
Fuel line screen (at carburetor).....	Remove and clean ( <i>refer to page 31</i> ).
Cooling system.....	Clean ( <i>refer to page 33</i> ).
Engine valves.....	Check for clearance ( <i>refer to page 35</i> ).
Clutch pedal.....	Check for free movement ( <i>refer to page 36</i> ).
Brakes.....	Check for free movement and equalization ( <i>refer to page 37</i> ).
Lubrication Points (500 hours) .....	<i>See Lubrication Chart.</i>

\*—When unusual dust or dirt conditions are encountered during operation it may be necessary to service these points more frequently.

# AIR CLEANING SYSTEM

Clean air for combustion is assured by an oil-type air cleaner. A heavy screen in the air intake cap prevents large particles from entering the air cleaner. The air then passes to the oil cup where it goes through a bath of oil. As the air rises to the intake manifold it passes through a series of oil-bathed screens and the fine dust is removed. As the oil from the screen works back down, it carries the dirt with it and settles in the oil cup. The oil cup must be cleaned and refilled regularly with new oil.

## Oil Cup

Clean and refill the oil cup every day, or every 10 hours of operation (more frequently when operating under dusty conditions). Refill the oil cup to oil level bead with the same grade of oil used in the engine crankcase. The capacity of the oil cup is  $\frac{3}{4}$  U.S. pint.

Before replacing the oil cup, clean or wipe oil or grit from top bead of oil cup, oil cup retaining clamp, and the surface under the clamp.

## Air Intake Cap and Screen

The screen in the air intake cap prevents chaff and other coarse dirt from getting into the air cleaner. This screen should be kept clean and free from all chaff, oil, dust, or paint as clogged holes in the screen will reduce the power of the engine by restricting the flow of the air.

## Washing the Cleaner

After every 60 hours of operation—particularly if operating the tractor in an atmosphere heavily laden with dust, chaff or lint—remove the entire air cleaner from the tractor, completely disassemble it, and wash the parts thoroughly in kerosene. Be sure to clean out the air intake pipe.

After all parts have been thoroughly cleaned, replace the air cleaner body on tractor. Make sure all joints are air-tight. Replace the air intake cap. Fill the oil cup to the proper level with the specified

grade of oil and replace it on the air cleaner. Be sure it is held securely in place by the cup clamp.

## General Precautions

As an added precaution against dirt getting into the engine, frequently inspect the flexible rubber hose connections between the carburetor and the air cleaner. If they show any sign of deterioration, replace them.

To eliminate strain on the rubber hose connections, be sure pipes line up.

All joints between the air cleaner and carburetor, manifold and the cylinders of the engine should be tight. All gaskets must be in a good condition and the bolts should be drawn up tight.

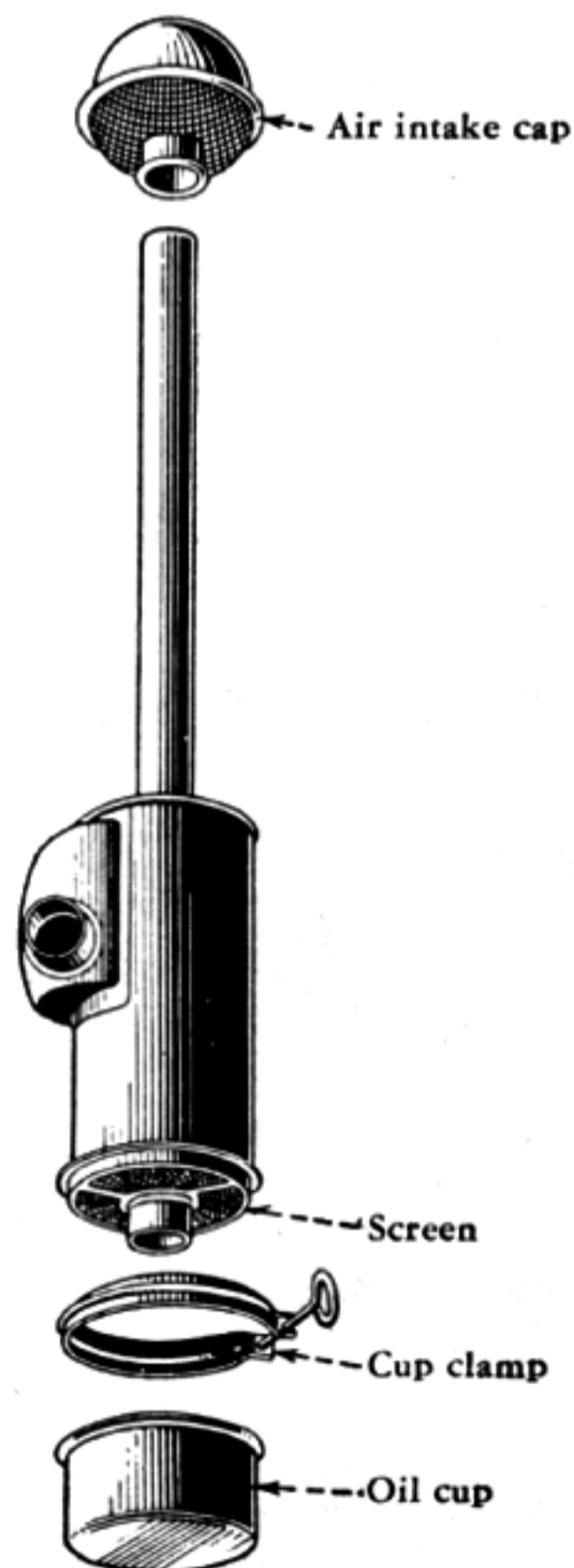

Illust. 12

"Exploded" View of Air Cleaner  
Removed from Tractor.

# OIL FILTER

The life of your engine depends upon clean oil being circulated to all bearings. Every good tractor operator knows that minute particles of abrasive matter eventually accumulate in the crankcase of the engine, and that in the normal course of engine operation, the lubricating oil undergoes changes which produce sludge, acids, gums, varnish, and other harmful by-products.

The purpose of the oil filter is to separate and remove the dirt and other foreign substances from the oil to prevent these injurious materials from being circulated to the engine. This filter is so efficient it will keep the circulating oil free of harmful contamination for one hundred and twenty hours of operation—at which time the oil should be changed and the inexpensive filter element replaced. Refer to "Lubrication Chart" for the recommended oil to use for the prevailing temperature. Close adherence to the simple, common-sense procedure for keeping dirt and oil impurities away from precision-made engine parts will safeguard your tractor engine against undue wear and the operating troubles and upkeep expense which are a natural result of that condition.

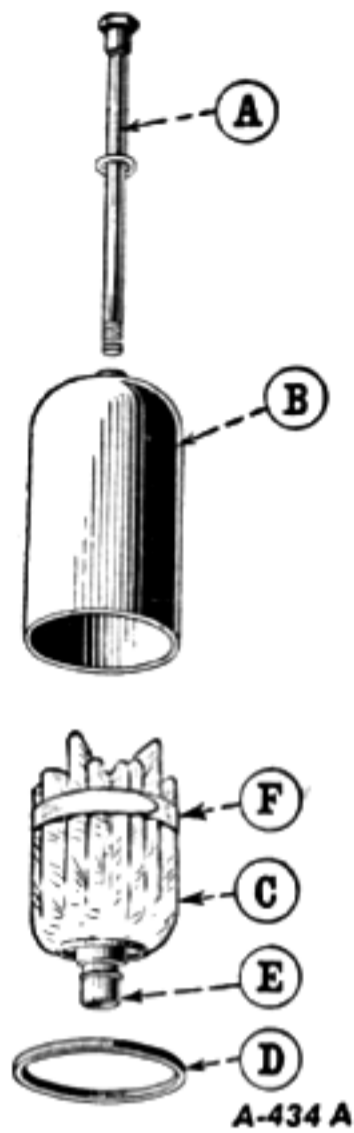

Illustr. 13

Detail of Oil Filter.

**NOTE:** If some special equipment on the tractor prevents the lifting of case "B" over element "C," remove the case and the element together.

(7) Wipe out base and the case with a cloth dampened with kerosene.

(8) See that the case gasket "D" is in position. Replace the drain plug in the filter base and install the new filter element, with band "F" around element (pilot "E" must be down). Replace the case and retaining bar and draw the nut up tight.

(9) Check the oil level in crankcase to see that the new oil is up to the proper level (see "Lubrication Chart"). Now start up the engine, see that oil pressure indicator is registering pressure, and inspect the filter for oil leaks.

**NOTE:** To avoid delays, the owner should carry extra elements on hand for replacement at the proper time.

## To Change Filter Element

- (1) Stop the engine.
- (2) Remove oil filter base drain plug and allow the oil filter to drain completely.
- (3) Clean off the filter case to eliminate any possibility of dirt dropping into the base.
- (4) Unscrew and remove the retaining bar "A."
- (5) Lift up and remove case "B."
- (6) Remove the old element "C."

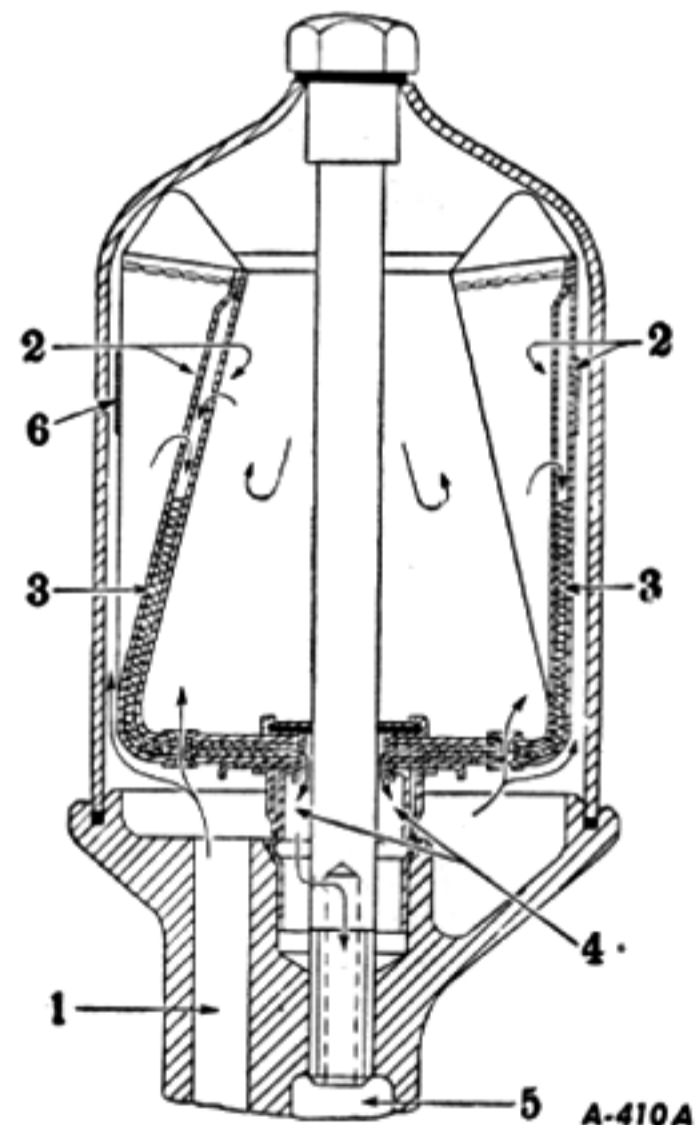

Illustr. 14

Cutaway view of filter showing: (1) oil inlet, (2) replaceable filtering element, (3) mesh screen separator to provide passage for filtered oil between inner and outer layer of element, (4) outlet for filtered oil, (5) filtered oil return, (6) band holding folds of element together.

# SPARK PLUGS AND CABLES

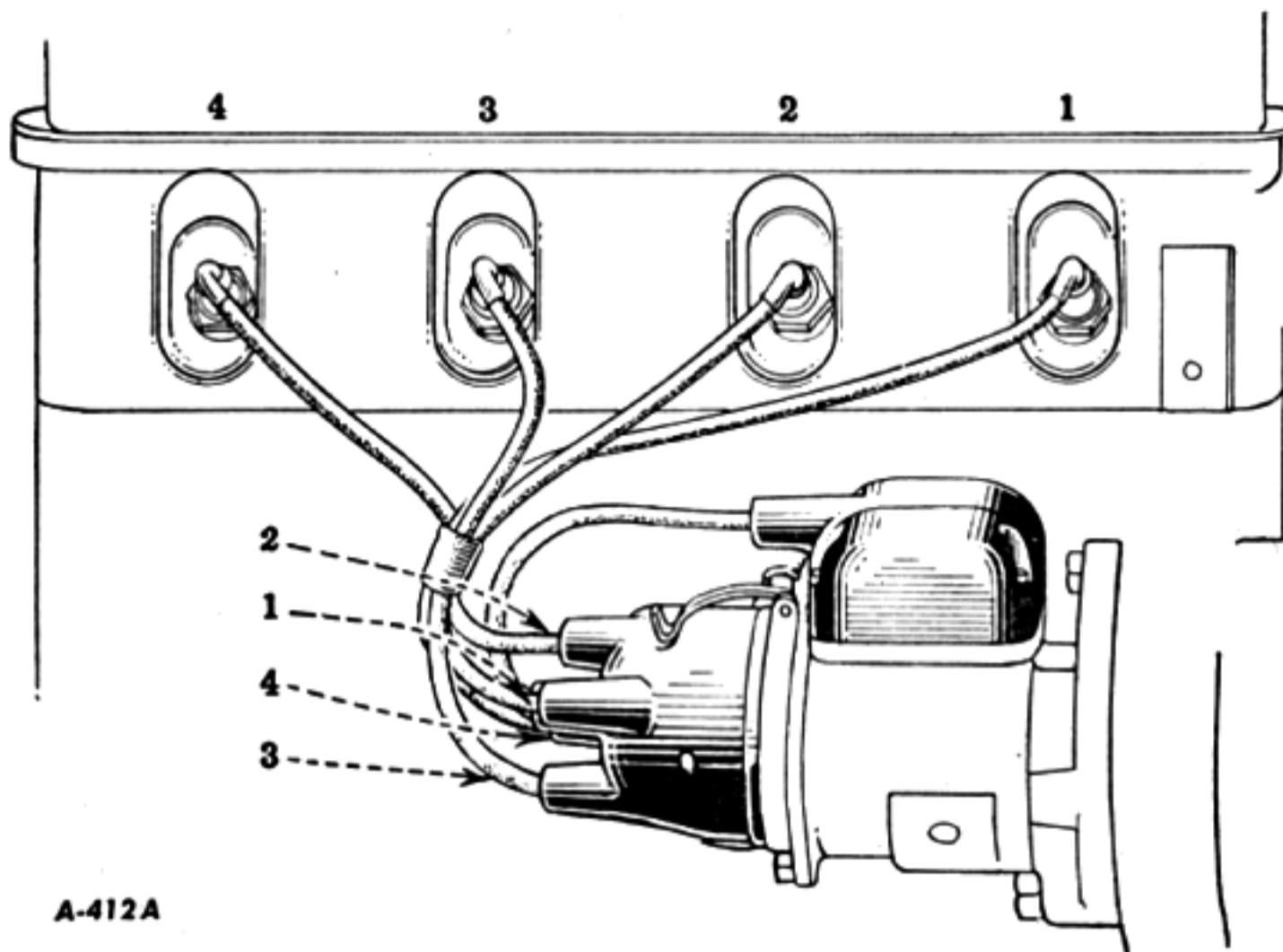

A-412A

Illust. 15

H-4 Magneto—Wiring Chart.  
Engine firing order is 1, 3, 4, 2.

## Spark Plugs

The spark plugs selected after careful tests as best suited for this engine are the Champion No. 15A or AC-87 and should be used ordinarily. Use only a complete set of either type of spark plug.

Spark plugs should be removed after every 200 to 300 hours of operation, or oftener if necessary, for cleaning and checking gaps between electrodes. A gap of .028 inch to .032 inch should be maintained (a gauge of this thickness is furnished). When making this adjustment, always bend the outer electrode. Never bend the center electrode as it may damage the insulator. If the gap between the electrodes is too great, due to improper setting or burning off the ends, engine will misfire and be hard to start.

## Special Spark Plugs

(For Special Spark Plugs See Your  
International Harvester Dealer)

To remedy fouling or sooting, use a hotter (light service) spark plug.

To remedy preignition and burning of electrodes, use a colder (severe service) spark plug.

## Cleaning Spark Plugs

Sand blasting is the recommended method of cleaning spark plugs. Never scrape or clean the insulator with anything which will scratch the porcelain. Scratched porcelain allows carbon and dirt to accumulate much faster.

## Spark Plug Cables

If Spark plug cables are removed for any reason, note the position of each cable on magneto. (*Wiring Chart—Illust. 15—shows correct wiring.*)

There should be  $\frac{1}{4}$ -inch minimum clearance between spark plug cables and cylinder head. By maintaining this clearance, shorting-out the spark plug will be prevented and the cable will be away from the extreme heat of the cylinder head. If the cable touches the head, heat soon causes the rubber to become soft and ruins the cable.



---

**LUBRICATION CHART**  
**FOR**  
**FARMALL-A AND -AV**  
**TRACTORS**

---

## GENERAL ENGINE LUBRICATION

The life of any tractor depends on the care it is given. Proper lubrication is very important.

This engine has a pressure feed lubrication system. A gear type oil pump circulates the lubricating oil under pressure to crankshaft bearings, connecting-rod bearings, valve mechanism, timing gears, and governor, thereby assuring positive lubrication of all parts.

The engine is equipped with an oil filter which continually cleans the oil while engine is running. To secure the full benefit from the filter, the element should be replaced with a new one every time the oil is changed in the crankcase (*every 120 hours of operation*). *Cleaning the old element is not satisfactory.*

To pour oil into the engine, remove breather from oil filler pipe on valve housing. Test cocks are located on the side of the crankcase pan, which indicate the high and low level of the oil. The oil should never be above the high level nor below the low level. (See "*Lubrication Chart*".)

*Never check oil level while engine is running.*

### Oil Pressure Indicator

An oil pressure indicator shows whether or not engine is being properly lubricated. Under all operating conditions, the oil

pressure of the engine should hold the indicator in the white section. Should the indicator not register, stop the engine at once and inspect oil system to find the cause of failure. If unable to find cause, consult your International Harvester dealer before operating engine.

*Always look at the oil pressure indicator immediately after starting engine.*

### Oil Pump

The gear oil pump in the crankcase has a screen attached to the oil intake to stop large dirt particles from entering the oiling system. This screen should be cleaned whenever the oil pan is removed.

### Breather

The crankcase breather cap, which is also the cap for oil filler pipe, is located on top of valve housing. Remove breather cap and clean every 120 hours of operation, and under severe dust conditions, more frequently.

To clean, wash breather cap in kerosene, dip in engine lubricating oil, and replace after wiping off excess oil.

### Special Equipment

If your tractor has any special equipment such as belt pulley, electric starting, or lighting, refer to the Owner's Manual for this equipment for maintenance information.

# ENGINE LUBRICATION CHART

NOTE: The symbols shown around the reference numbers on the illustrations indicate the intervals of lubrication.

## KEY TO LUBRICATION CHART

The specifications of the lubricants referred to are listed on the back of this chart, page 25. Paragraph numbers refer to corresponding numbers on illustrations.

### △ — DAILY OR EVERY 10 HOURS OF OPERATION

- 1. Oil Filler.
- 2. Upper Oil Level Test Cock.
- 3. Lower Oil Level Test Cock.

WHEN OPERATING ON GASOLINE  
Add sufficient new oil to bring oil up to level of upper test cock (2).

WHEN OPERATING ON DISTILLATE  
Open the lower test cock (3) in the crankcase pan and allow the oil to drain to this level. Close the lower test cock and open the upper cock (2) then add new oil until oil appears at the upper cock. Close the cock. Oil level should not be checked while engine is running nor should the engine be run with oil below lower test cock.

- 4. Air Cleaner.....

Clean and refill oil cup to oil level bead with same new oil as used in engine crankcase (capacity  $\frac{3}{4}$  U.S. pint). Refer to page 20 for more information.

### ○ — WEEKLY OR EVERY 60 HOURS OF OPERATION

- 5. Fan Hub Filler Plug.....

Remove plug and fill hub half full with engine oil and replace plug. To fill, set fan so plug is at left-hand horizontal position.

- 6. Impulse Coupling.....

Use a light oil such as sewing machine or cream separator oil and oil liberally.  
Use kerosene when temperature is below 10°F.

### ◇ — EVERY 120 HOURS OF OPERATION

- 7. Crankcase Pan Oil Drain Plug.

Remove plug (7) and drain all oil from crankcase pan. Refill with new oil to level of upper test cock (2). Crankcase pan capacity is approximately 5 U.S. quarts. For the correct lubricating oil to use, refer to specifications listed on back of chart.

- 8. Oil Filter Element.....

Replace oil filter element at the same time engine crankcase oil is changed. (See page 21.)

### ○ — PERIODICAL

- 9. Magneto.....

Every 500 hours of operation fill distributor bearing oil cup with very light oil such as cream separator or sewing machine oil. Refer to page 27 for complete information on magneto lubrication.

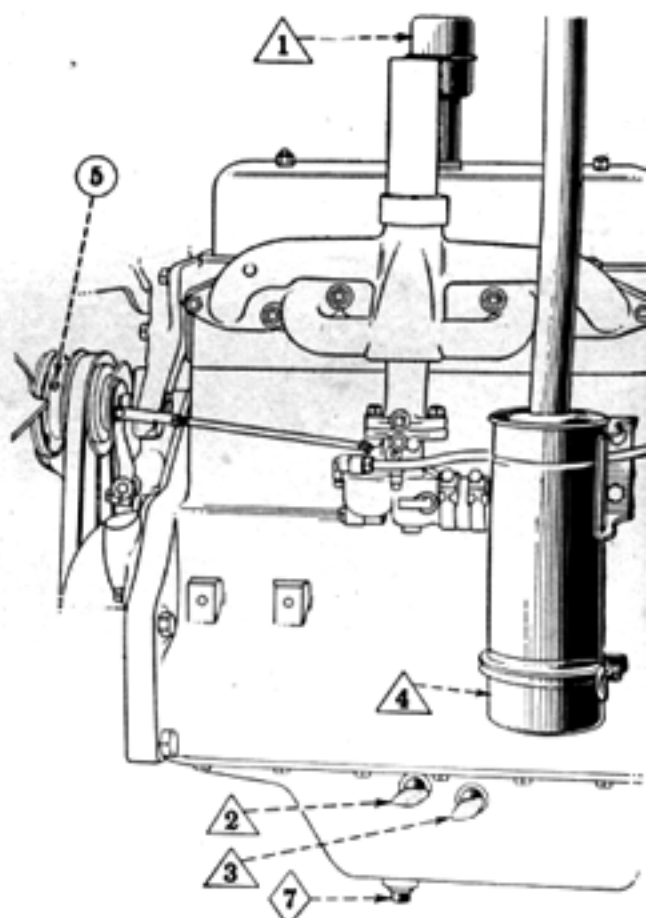

Left side of engine

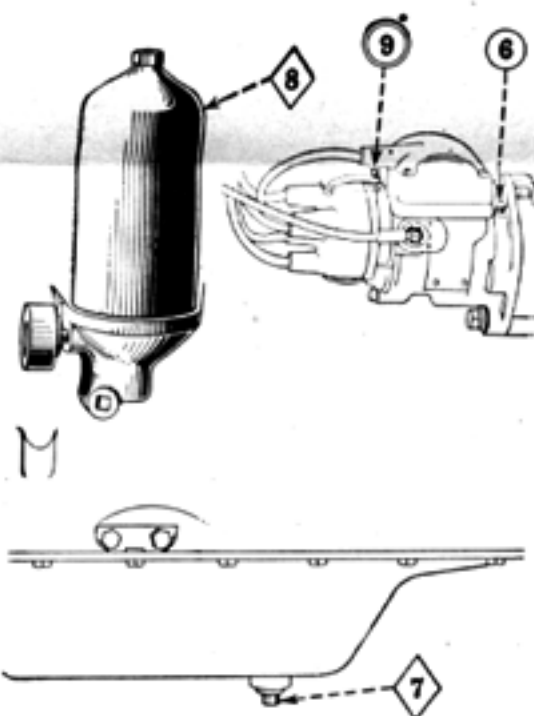

Right side of engine

## CHASSIS LUBRICATION CHART

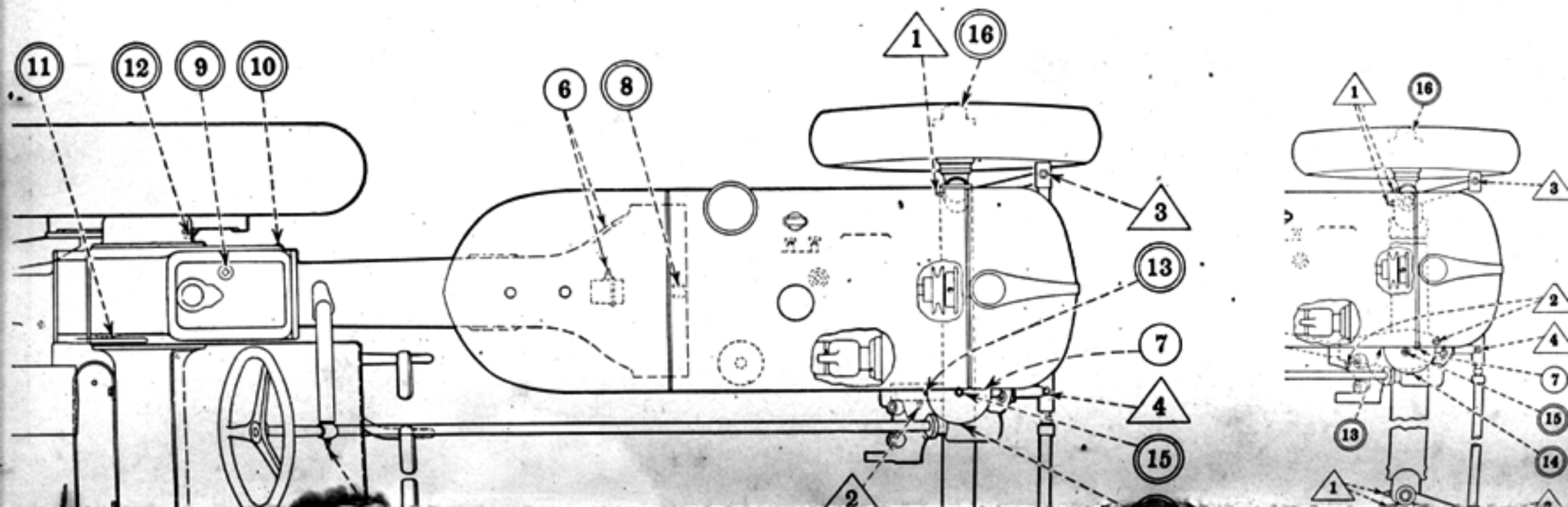

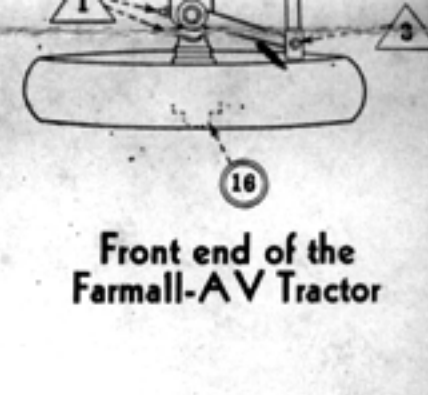
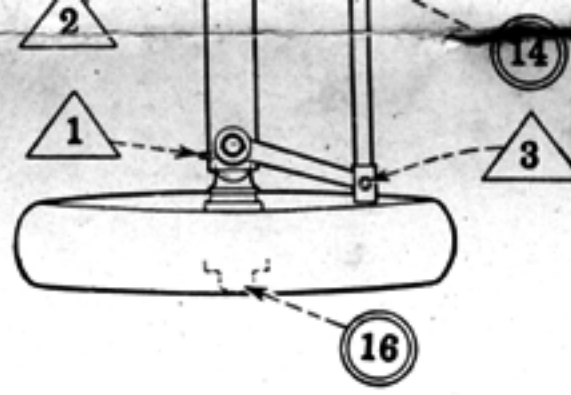
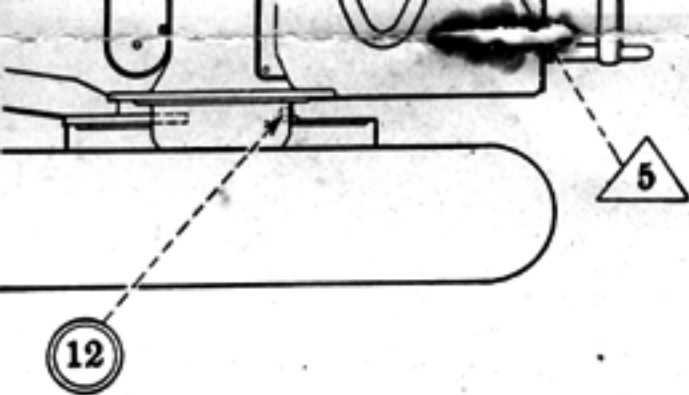

Top View of Tractor

Front end of the Farmall-AV Tractor

**NOTE:** This illustration will apply for Farmall-A and Farmall-AV Tractors, except the front end, which is for Farmall-A Tractor only. For front end of Farmall-AV Tractor see adjoining illustration.

**△ — DAILY OR EVERY 10 HOURS OF OPERATION**

- 1. Steering Knuckle Post for Farmall-A Tractor (2) Steering Knuckle Post for Farmall-AV Tractor (4).....
- 2. Front Axle Pivot for Farmall-A Tractor (1) Front Axle Pivot for Farmall-AV Tractor (2).....
- 3. Tie Rod (2).....
- 4. Tie Rod Ball Seat (1).....
- 5. Steering Shaft Support Bracket (1).....

Use pressure gun grease (chassis lubricant) and apply 2 or 3 strokes of lubricator, or sufficient grease to flush out the old grease and dirt.

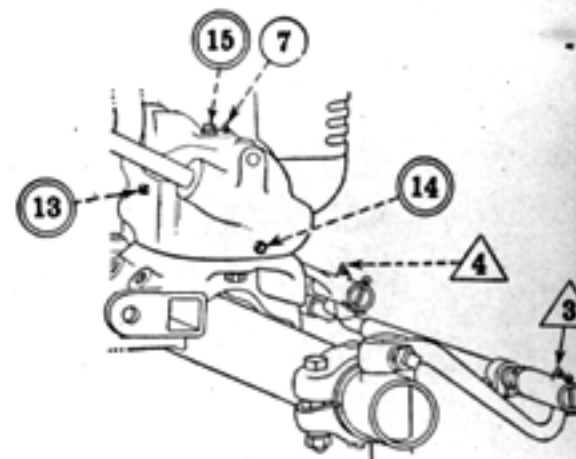

Front end of Tractor

**○ — WEEKLY OR EVERY 60 HOURS OF OPERATION**

- 6. Clutch Release Bearing.....
- 7. Steering Worm Wheel Shaft Bearing.....

Use pressure gun grease (chassis lubricant) and apply ten complete strokes of the lubricator. Fitting can be reached through hole in left-hand side of clutch housing.

Use pressure gun grease (chassis lubricant) and apply equivalent of two strokes of lubricator.

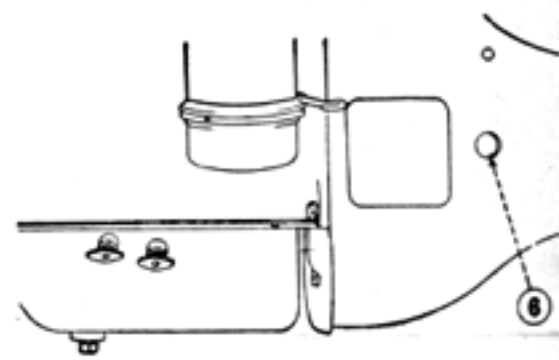

Clutch release bearing lubrication point

**○ — PERIODICAL**

- 8. Clutch Pilot Bearing.....
- Transmission and Differential.
- 9. Oil Filler Plug.
- 10. Oil Level Plug.
- 11. Oil Drain Plug.
- 12. Rear Axle Housing Oil Filler and Level Plugs (2).....

Does not require lubrication (oil-less bushing).  
Use approved lubricant. Keep lubricant up to level of plug (10) on left front side of transmission case. Check oil level periodically.

The oil in the transmission case should be changed at least once a year. However, do not run tractor more than 1,000 hours without changing oil in transmission case. If the oil in transmission case has been thinned with kerosene for operation in temperatures below zero, the oil should be changed before hot weather.

For capacity of transmission case see "Specifications" on inside of back cover.

Check oil level periodically and keep lubricant up to level of filler plug. Use approved lubricant. The oil should be changed at least once a year. However, do not run tractor more than 1,000 hours without changing the oil. Drain and refill to level of plug (12). Capacity 3 U.S. pints on each side. To drain, remove rear axle housing pan. Clean the pan and replace it.

Check periodically and add sufficient approved lubricant to level of plug (13).

The oil should be changed at least once a year. However, do not run tractor more than 1,000 hours without changing the oil.

Drain by removing plug (14) and refill with new lubricant. Capacity 1 U.S. quart. To fill, remove filler plug (15) and fill to level plug.

Once every 6 months, remove, clean, and repack front wheel bearings with pressure gun grease (chassis lubricant). Refer to page 26 for further instructions.

Occasionally, put a few drops of engine oil on linkage or connections of control rods such as governor, radiator shutter, power take-off, etc.

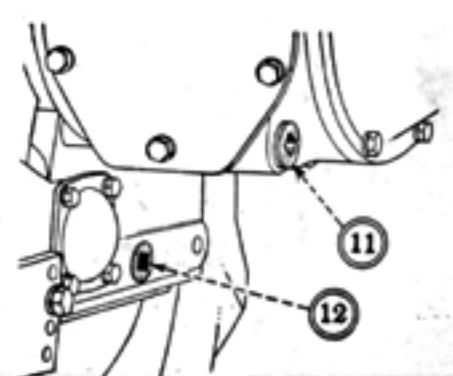
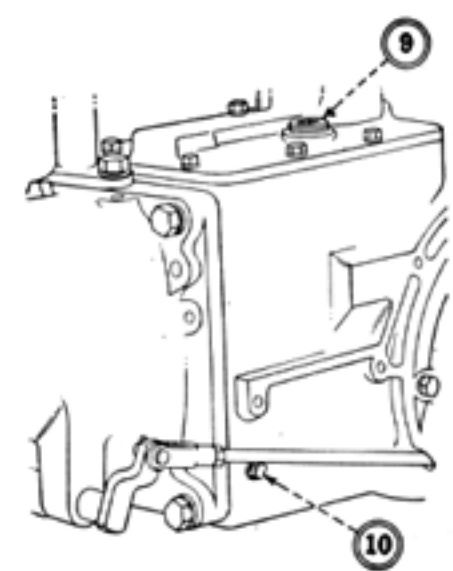

- Steering Gear Housing.
- 13. Level Plug
- 14. Drain Plug.
- 15. Filler Plug.

- 16. Front Wheels.....
- Miscellaneous Parts.....

# LUBRICATING OIL AND GREASE SPECIFICATIONS

## ENGINE LUBRICATING OILS

**NOTE:** Engine lubricating oil shall be of well-refined petroleum oils, free from water, sediment, and without admixtures, of fatty oils, acids, soaps, resins or any other substance not derived from petroleum. Oil shall not corrode any metal used in engine construction. Also engine lubricating oil containing additive products not necessarily derived from petroleum, but being of noncorrosive type, is satisfactory for use in our engines.

### VISCOSITY OF LUBRICATING OILS RECOMMENDED

Air Temperature	Engine Crankcase	Air Cleaner	Magneto and Impulse Coupling
Above 32°F.	SAE-30	SAE-30	Very light oil such as Cream Separator or Sewing Machine Oil
32°F. to 10°F.	20W	20W	Very light oil such as Cream Separator or Sewing Machine Oil
Below 10°F.	10W	10W	Very light oil such as Cream Separator or Sewing Machine Oil(*)

(\*) Use kerosene in impulse coupling for temperatures below 10°F.

*Refer to special instructions for Cold Weather Operation on page 18.*

To aid easier starting, the selection of crankcase lubricating oils should be based on the lowest anticipated temperature for the day. It is not necessary to change the crankcase oil every time the temperature rises or falls into another temperature range during some part of the 24-hour day. For example, SAE-30 may be used in temperatures below 32°F. if no starting trouble is experienced, and 20W oil can be used in temperatures around 50°F. 10W may be used up to 32°F. except when operating continuously on heavy loads. SAE-10 and SAE-20 oils may be substituted for 10W and 20W except if engine is difficult to crank.

### APPROVED LUBRICANT FOR TRANSMISSION, DIFFERENTIAL, STEERING GEAR, AND REAR AXLE HOUSING

Tractors are shipped from the factory with SAE-90 oil in the transmission, differential, steering gear, and rear axle housing.

For all temperatures above zero, use SAE-90 transmission lubricant. For temperatures below zero, use the same transmission lubricant as for above zero, but also pour 1½ U.S. pints of kerosene into the transmission case and ½ U.S. pint of kerosene into each rear axle housing.

After the kerosene is put in these compartments, run the tractor until the mixture is thoroughly warm. Then drain the transmission case to level of plug (10) and check the level of lubricant in the rear axle housing as described in the lubrication chart.

Use a good grade mineral oil free from solid materials. Use only high quality lubricating oils and grease. For your own protection, select only oils and grease of recognized manufacture.

### LUBRICATOR FITTING GREASE

Use pressure gun grease (chassis lubricant) for lubricator fittings on which hand lubricator is applied.

**IMPORTANT:** Keep the supply of lubricating oil absolutely clean and free from dust. Always use clean containers. Keep lubricator clean and wipe dirt from grease fittings before applying lubricator.

# ADJUSTING AND GREASING FRONT WHEELS

## Removing and Greasing

To grease front wheels, raise front end of tractor until the wheel clears the ground. Remove hub cap "A," remove cotter pin, remove nut "B" and washer "F." Remove bearing "C" and place in hub cap "A" or clean container; then remove wheel. Clean inside of hub "D" and repack with pressure gun grease (chassis lubricant).

Remove old grease from bearings and clean thoroughly with kerosene.

It is advisable to leave bearing "E" on the axle and clean with brush and kerosene. Apply new grease on rollers before re-assembling bearings.

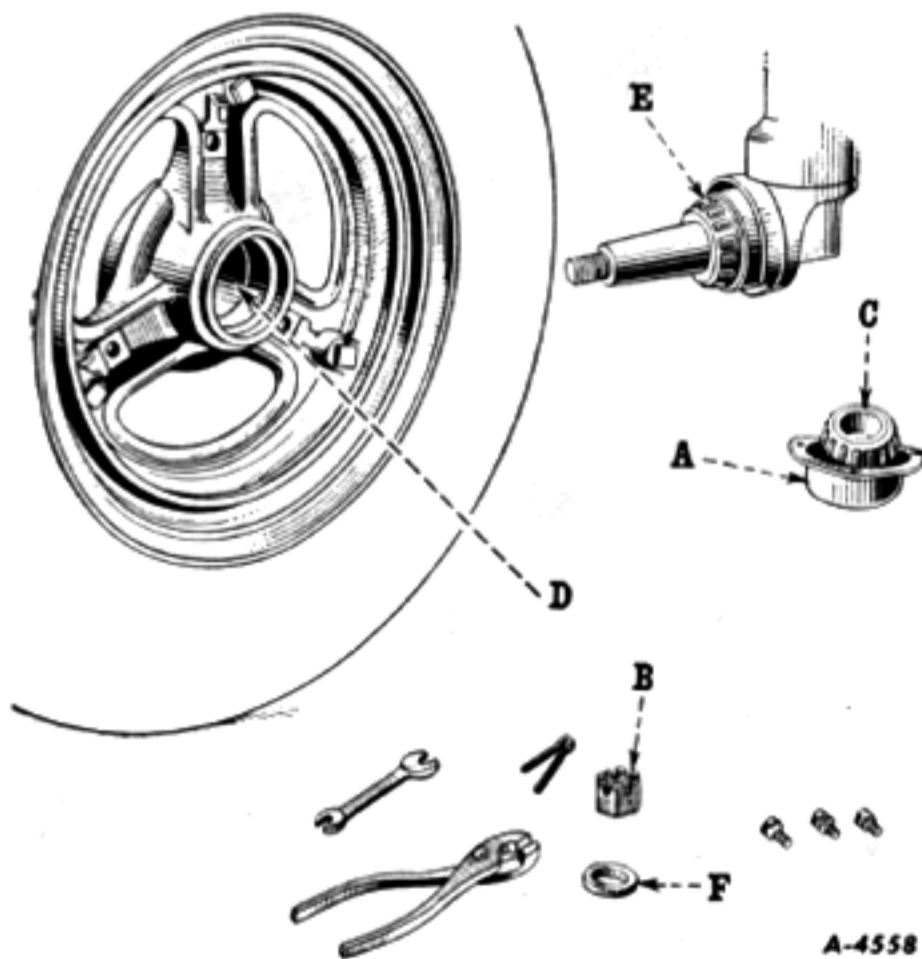

Illust. 16

## Replacing and Adjusting

Reassemble wheel, tighten nut "B" until wheel binds slightly, rotating wheel at the same time. Back nut off one castellation from the cotter pin hole; replace cotter pin and hub cap.

*Be sure to keep all parts clean.*

## Assembling Rim Clamp (For Farmall-A Tractors only)

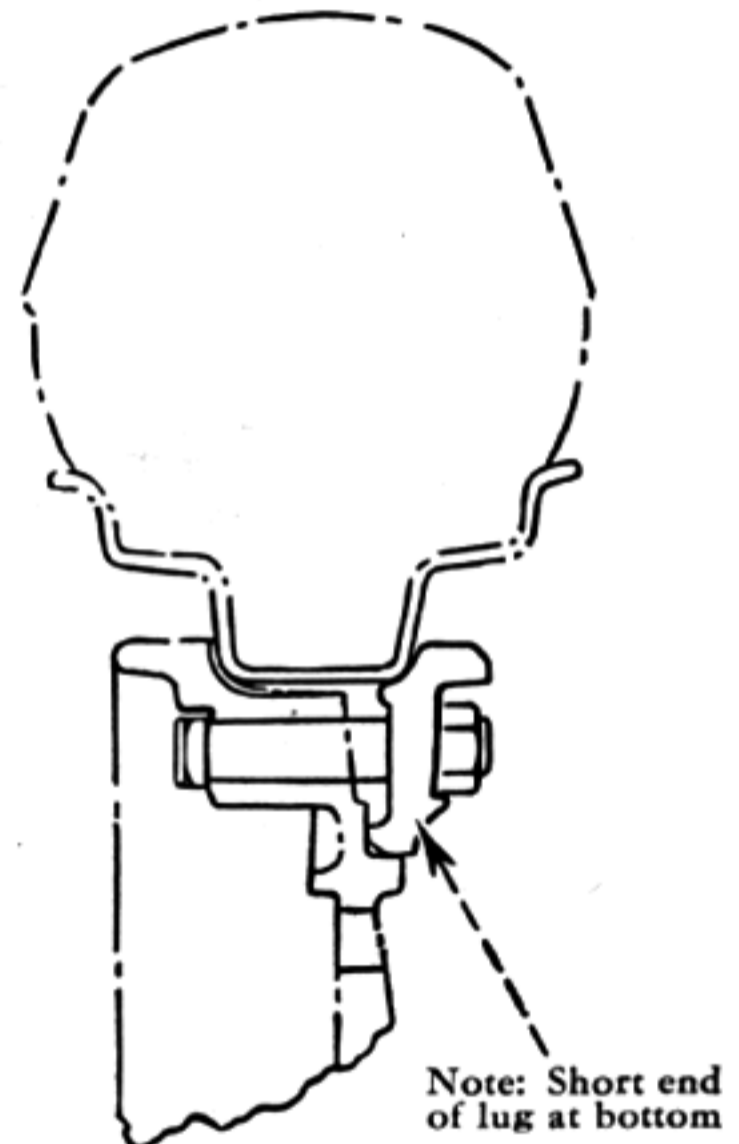

Illust. 17

Showing Method of Assembling Front Wheel Rim Clamps.

When assembling the front wheel rim, be sure to assemble the clamp in the correct position *as shown in Illust. 17*. Tighten clamp bolts securely and equally to prevent misalignment of rim on wheel.

# MAGNETO

Your tractor is equipped with a high-tension magneto which is designed and built in accordance with the latest ignition practices. A magneto of this type is used by International Harvester because our engineers have proved that it is superior from the standpoint of performance, long life, and trouble-free operation.

## Lubrication

Every week, or every 60 hours of operation, oil the impulse coupling liberally with a light oil such as cream separator or sewing machine oil. Use kerosene when temperature is below ten degrees Fahrenheit.

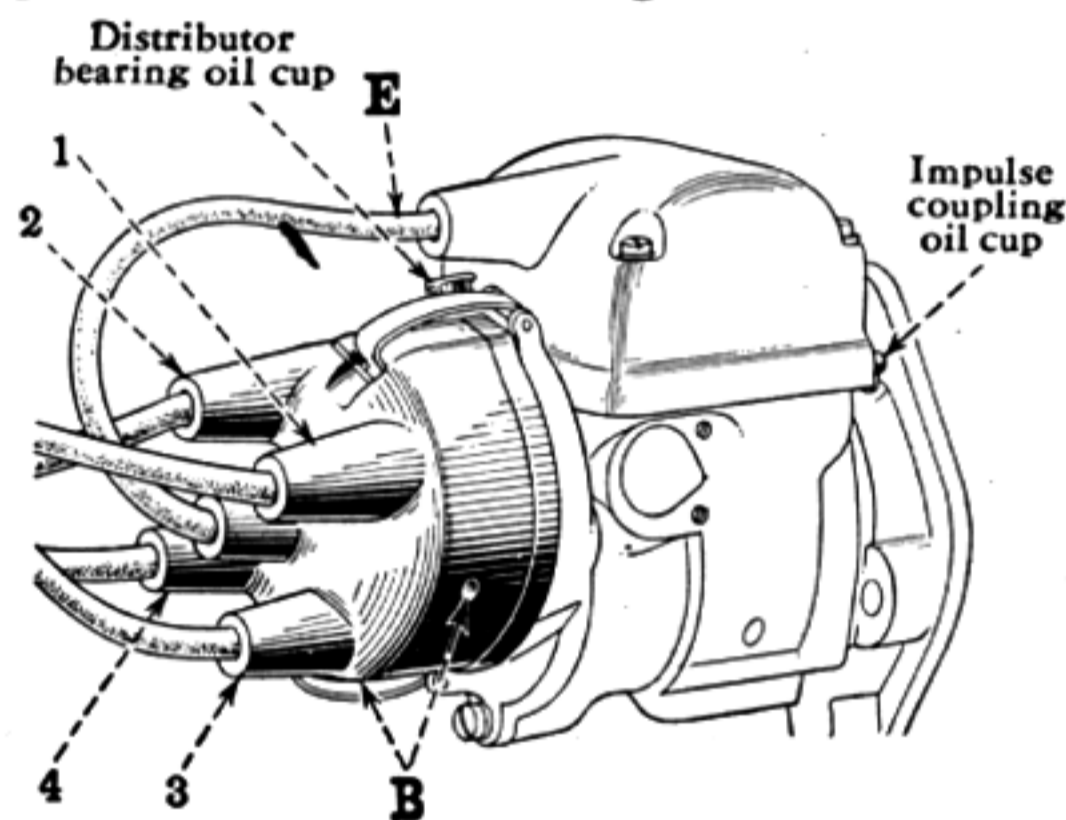

Illust. 18

Clockwise Rotation (viewed from the distributor end).

Every 500 hours of operation, fill the distributor bearing oil cup with very light cream separator or sewing machine oil. Do not oil oftener as excessive oil might work into the breaker point chamber and cause rapid point wear.

## Greasing Breaker Mechanism and Checking Points

Your magneto requires very little attention other than properly lubricating the oil cups as specified above.

It is important, however, to keep the breaker arm chamber clean, as oil on the breaker points will cause rapid point wear. Over-lubrication of the distributor bearing oil cup (see *Illust. 18*) might cause a dirty breaker point chamber. After every 250 hours of operation the breaker point

chamber should be inspected to assure that it is clean. See that the points are in good condition and have the proper clearance. If the chamber is clean, no attention is necessary other than checking the clearance of the points; but if the chamber is dirty, all parts must be thoroughly cleaned. After cleaning, the points should be dressed, the point clearance checked, and the breaker arm regreased as outlined below.

To reach the breaker mechanism, remove the distributor cap and crank the engine slowly until metal strip on distributor rotor points toward the No. 1 terminal on distributor cap and impulse coupling just trips. Remove the distributor rotor. Take off the distributor body by removing the three screws (see "A," *Illust. 19*). Do not crank the engine while distributor body is removed or it might be necessary to retune the magneto to the engine.

Pry the breaker arm and anchor from the chamber and clean all parts. Inspect the breaker points and, if necessary, dress them with a sharp fine file. If the points are worn excessively, replace both points.

Fill the recess in breaker post with grease and pack a small quantity of grease in back of the breaker arm rubbing block (see *Illusts. 19 and 20*). See your International Harvester dealer for the proper grease to use.

Assemble the breaker arm, leaving the spring anchor projecting  $\frac{1}{8}$  inch to  $\frac{3}{16}$  inch above top of slot so it is pushed into place by distributor body. Be sure the points line up after breaker arm is pushed into place.

Check the gap between the breaker points, using the gauge furnished with the tractor (see *Illust. 20*). The point opening should be .013 inch when the rubbing block is on the high part of the cam. If gap is not correct, adjust it by loosening the screw holding the adjustable point (see *Illust. 20*) and moving the point up or down until gauge slips snugly into opening.

## MAGNETO—Continued

When reassembling, be sure this shaft enters the "D" shaped hole in magnet rotor pinion

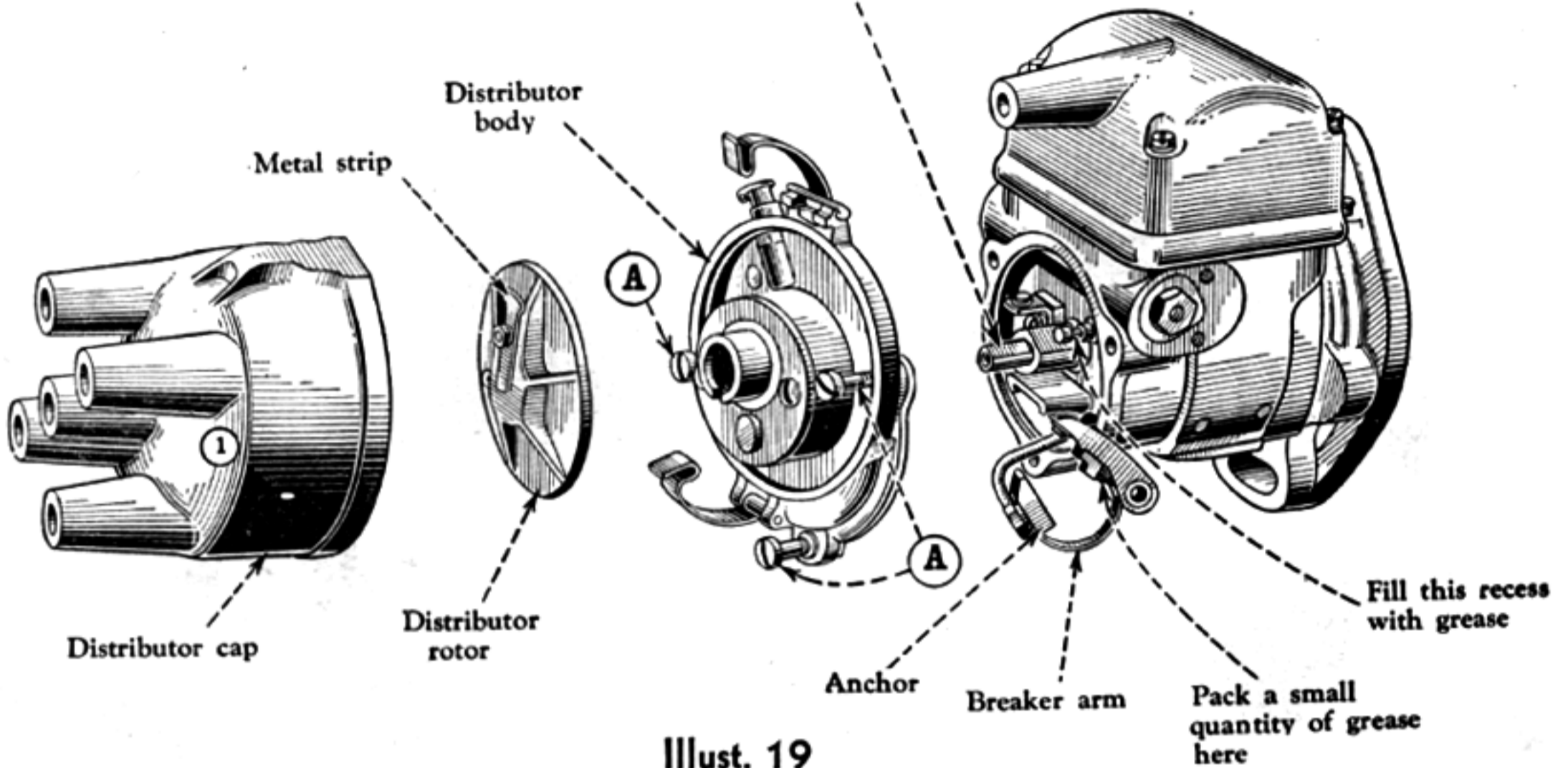

Illust. 19

After the proper adjustment has been made, tighten the screw.

Line up the distributor rotor key with keyway in spindle (*see Illust. 19*) and press rotor loosely on spindle. With the engine on top dead center of the No. 1 firing stroke, turn the distributor rotor until the metal strip on rotor points to the No. 1 terminal on the distributor cap. Place the distributor body on the magneto and be sure rotor shaft enters the "D" shaped hole in magnet rotor pinion. Remove the distributor rotor to tighten the three screws (*see "A," Illust. 19*). Replace the distributor rotor and distributor cap.

### Greasing Rotor Bearings and Distributor Gear Case

Every 2,000 hours of operation, or at least every two years, the magnet rotor bearings, distributor gear case, and distributor gear bearing should be cleaned and re-packed with IHC magneto grease. We recommend this be done by your International Harvester dealer.

### Distributor Cap

Both the inside and outside of distributor cap should be kept reasonably free of dust and oil deposits. To assure long life of the distributor, care must be taken to keep the two small ventilator holes (*see "B," Illust. 18*) open at all times. The distributor rotor should also be kept clean.

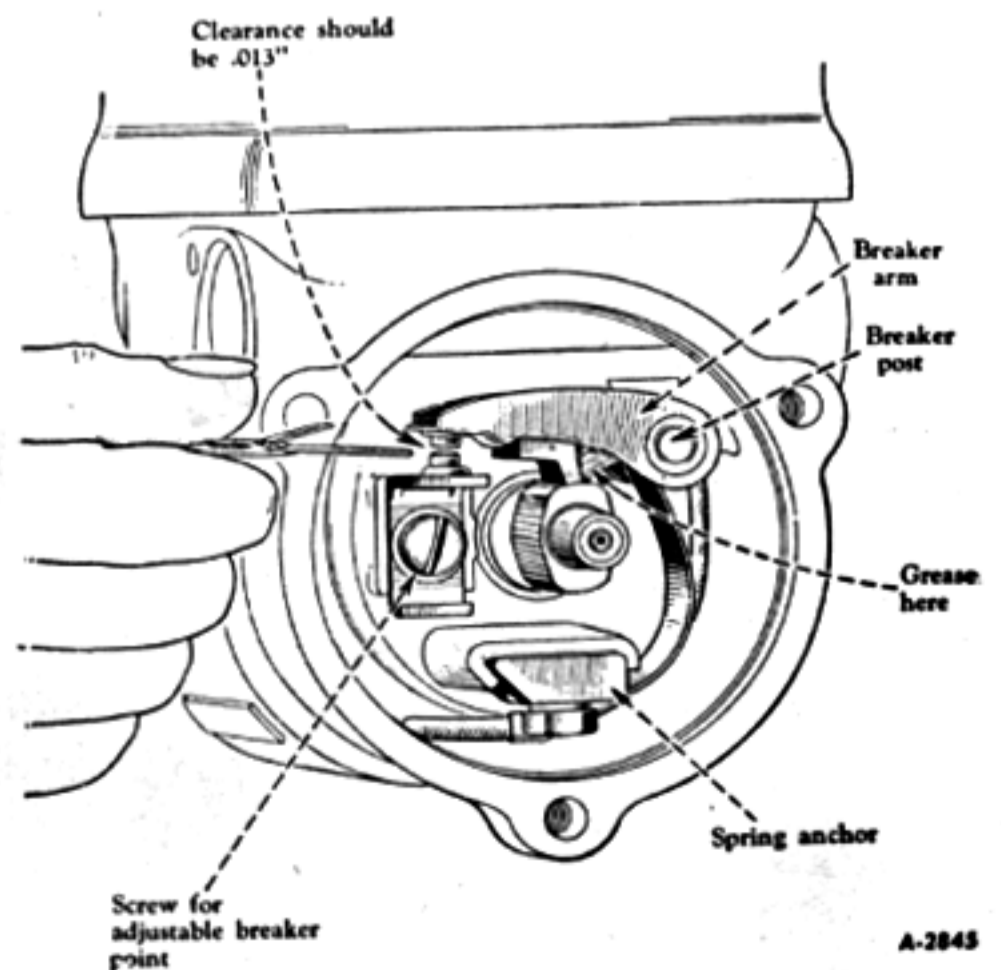

Illust. 20



## MAGNETO—Continued

### Removal of the Magneto

- (1) Take off the switch cable by removing the fillister head screw and lock washer attaching cable to magneto terminal.
- (2) Pull the spark plug cables from the sockets in distributor end of magneto.
- (3) Remove cap screws and washers holding magneto to bracket and take off magneto assembly.

## INSTALLING AND TIMING THE MAGNETO TO ENGINE

- (1) Pull out cable "E" (*see Illust. 18*) from the coil cover end. This will eliminate any possibility of accidental starting.
- (2) Crank the engine until No. 1 piston (the piston next to the radiator) is on the upper dead center of the compression stroke. The compression stroke can be determined by removing the No. 1 spark plug, placing the thumb over the opening, and cranking the engine until an outward-pressure is felt. Continue cranking slowly until the D.C. No. 1 mark on the flywheel is in line with pointer on clutch housing cover. (Timing pointer can be seen through opening in bottom of clutch housing—*see Illust. 21*.) Both intake and exhaust valves would then be closed.
- (3) Remove the distributor cap and turn magneto coupling in a counterclockwise direction (as viewed from the coupling end) until the metal strip on the distributor rotor points toward the No. 1 terminal on the distributor cap. Replace the distributor cap.
- (4) Assemble magneto on engine, making sure that lugs on the impulse coupling engage in slots on magneto drive coupling. (Assemble magneto so that top is as close to crankcase as possible.)
- (5) Insert magneto mounting bolts loosely in magneto flange, just enough to hold magneto in place. Then crank the engine one complete revolution to next top dead center. Now, pull the upper part of the magneto away from the engine until impulse coupling just trips.
- (6) Tighten mounting bolts securely. Attach spark plug cables to engine and magneto. Start by connecting No. 1 cylinder spark plug to socket marked "1" on distributor block, connect No. 3 socket with No. 3 cylinder, next with No. 4 cylinder, next with No. 2 cylinder. (*See Wiring Chart, Illusts. 15 and 18.*)
- (7) Connect the switch cable to the magneto terminal.
- (8) To check timing, crank engine slowly until top dead center of No. 1 cylinder is reached, at which time impulse coupling should just trip.
- (9) The magneto is now correctly wired and timed.
- (10) Push cable "E" back into socket in coil cover (*see Illust. 18*).

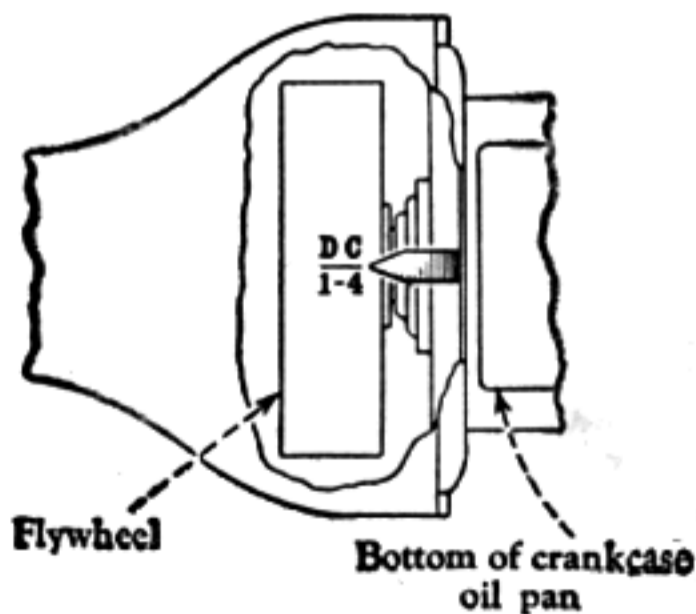

**Illust. 21**  
Timing Pointer.

(3) Remove the distributor cap and turn magneto coupling in a counterclockwise direction (as viewed from the coupling end) until the metal strip on the distributor

# CARBURETOR

## ZENITH

For Gasoline and Distillate or Kerosene Operation

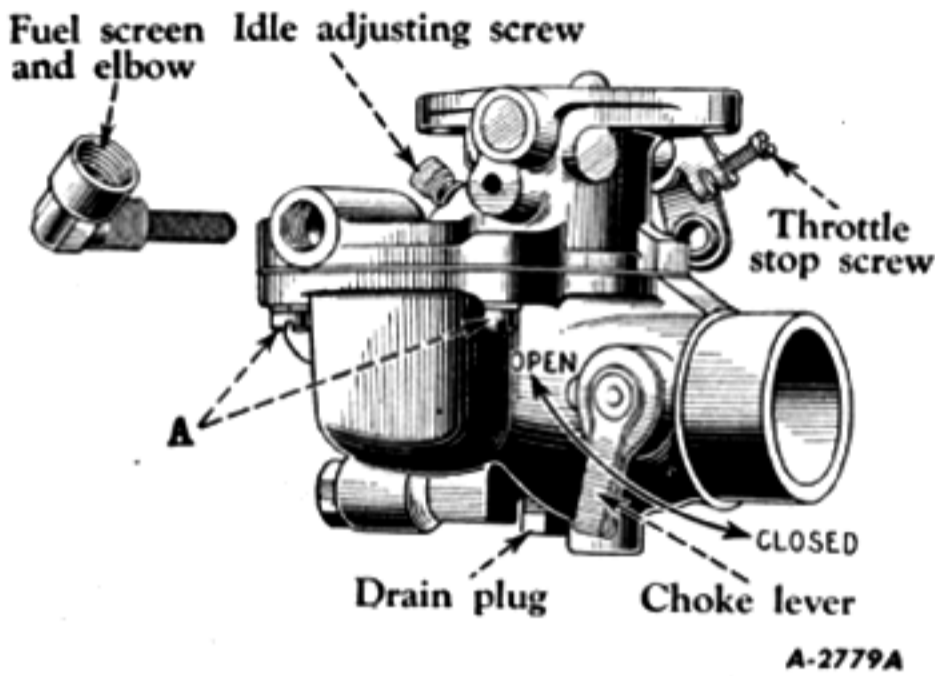

Illust. 22

Gasoline Carburetor Showing Carburetor Adjustment

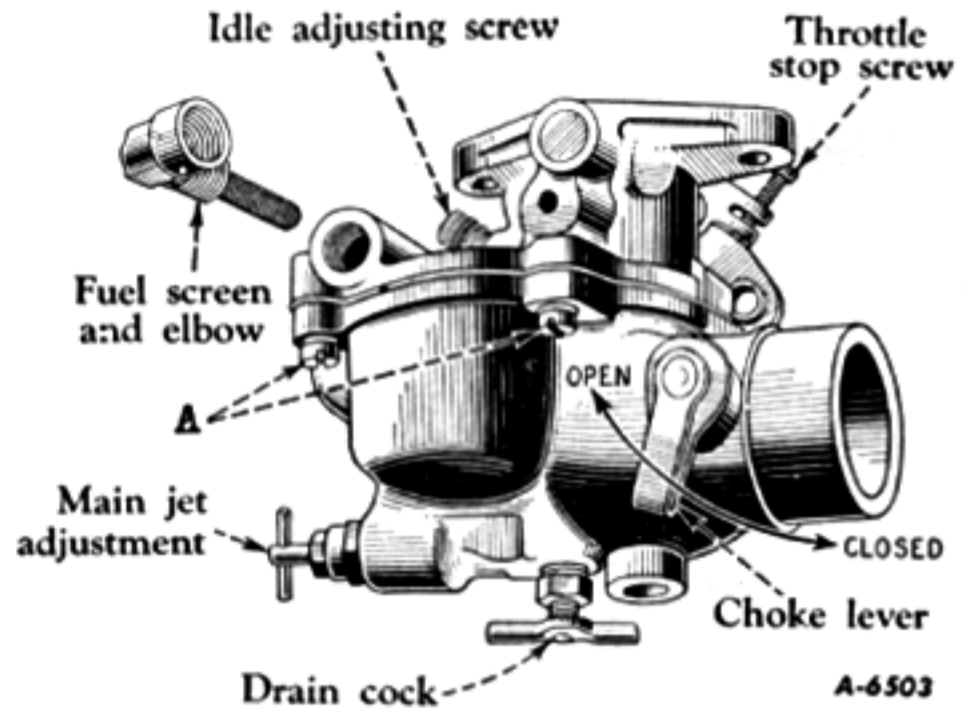

Illust. 22A

Distillate Carburetor Showing Carburetor Adjustment.

## MARVEL SHEBLER

Model TSX-157 for Gasoline Operation

Model TSX-156 for Distillate or Kerosene Operation

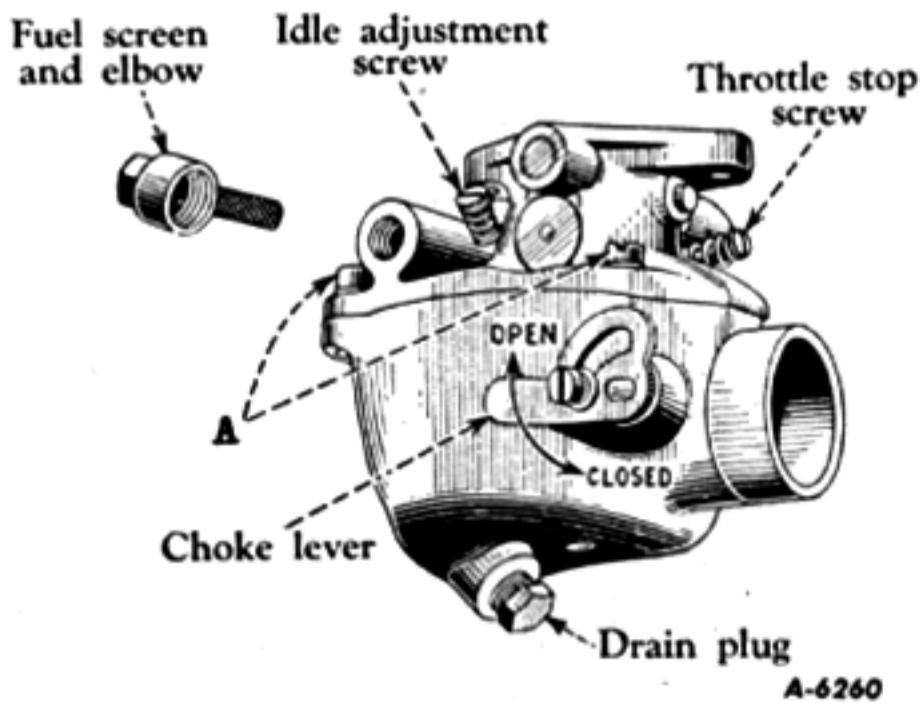

Illust. 23

Gasoline Carburetor Showing Carburetor Adjustment.

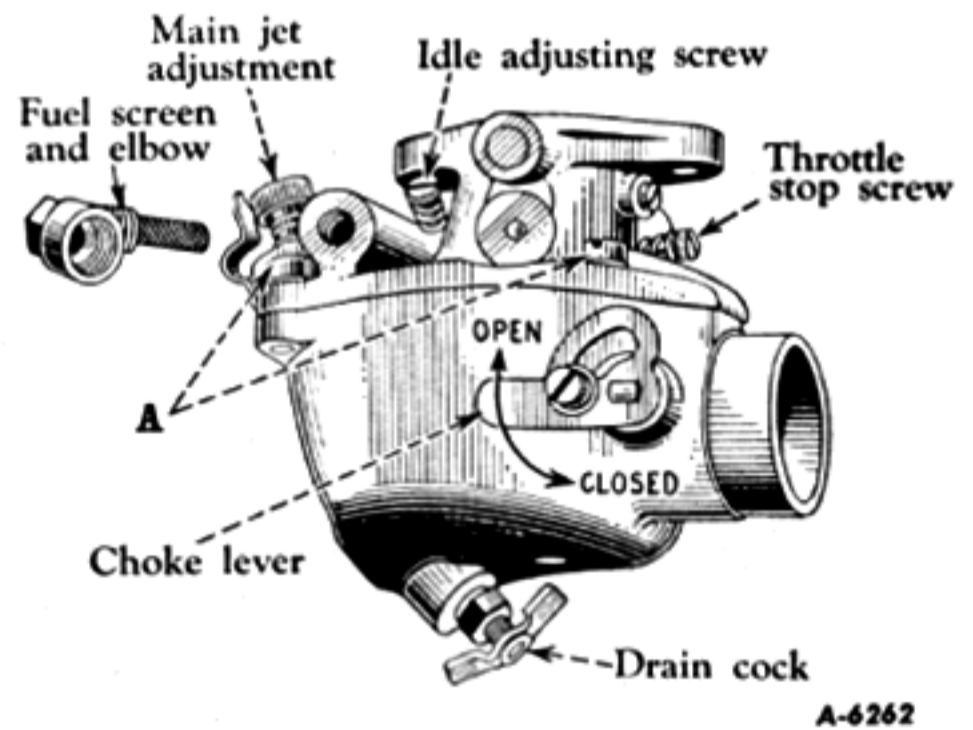

Illust. 23A

Distillate Carburetor Showing Carburetor Adjustment.

## CARBURETOR—Continued

### Instructions for Gasoline and Distillate or Kerosene Carburetors

The presence of dirt and water will disturb the functioning of the carburetor. Clean the fuel screen every 400 hours. Use clean fuel.

The fuel screen can be removed for cleaning by unscrewing fuel line fitting and removing elbow—clean the screen and replace it.

The flange nuts which hold carburetor to manifold should be checked periodically for tightness.

Occasionally check the cover screws "A" (see *Illusts. on page 30*) which fasten the fuel bowl to fuel bowl cover. They should be kept tight to avoid any air leakage past the fuel bowl cover gasket.

The engine and carburetor are correctly set when shipped from the factory. If, for any reason, this setting has been disturbed, the following procedure should be followed:

#### Adjusting Idle Adjusting Screw

Close idle adjusting screw to its seat by turning to the right (or in), then open one turn. Start engine and run at the fast idling speed (without any load) until thoroughly warm. (Cover radiator if necessary or close radiator if tractor is so equipped.)

Close the throttle by pulling governor control lever all the way back. If engine misses or rolls, slowly turn idle adjusting screw in or out until engine runs smoothly. Speed up engine for a few

seconds, then recheck idle. The idling speed is set by the throttle stop screw.

#### Main Jet Adjustment

*(For Distillate or Kerosene Carburetors Only)*

If your tractor is equipped for distillate or kerosene operation, set the manifold heat control valve in "Hot" position (see *Illust. 8A*) and allow engine to run on gasoline until thoroughly warmed up. (If the tractor is equipped with a water heat indicator the pointer should be on the high side of the "RUN" section). Then change over to operate on distillate or Kerosene and run the engine a short time before making adjustments.

To regulate the main jet adjustment, advance the governor control lever to fast idle position (push forward to advance), and turn the main jet adjustment clockwise until the fuel flow is shut off and the speed of the engine drops because of lean mixture; then open until engine runs smoothly. After engine has been put under load, if necessary, readjust the main jet adjustment. Always adjust so that engine runs smoothly with as lean a mixture as possible.

Recheck idling speed as described under "Adjusting Idle Adjusting Screw."

*(For Zenith Carburetor Only)*

If trouble is experienced in engine not getting correct mixture of fuel, it may be that the main jet adjusting screw has loosened. If necessary, tighten adjustment screw packing nut securely.

## CARBURETOR—Continued

### Removal of Carburetor

- (1) Shut off the fuel supply at the fuel tank.
- (2) Drain the carburetor by opening the drain cock.
- (3) Disconnect the choke and governor controls.
- (4) Disconnect the fuel line.
- (5) Remove the air cleaner connections to the carburetor.

- (6) Remove the two nuts and lock washers holding the carburetor to manifold and lift off the carburetor, complete.

### Installation of Carburetor

- (1) Install the carburetor on the engine in the reverse order of removal.
- (2) Turn on the fuel supply.
- (3) Adjust the carburetor as described previously.

## FUEL STRAINER

### Cleaning the Fuel Strainer and Sediment Bowl

The fuel strainer should be cleaned every 250 hours of operation; to do this, proceed as follows:

- (1) Close all shut-off valves.
- (2) Take the strainer apart by loosening the lower jam nut.
- (3) Clean out the sediment bowl and clean the screen if necessary.
- (4) When reassembling, be sure that the cork gasket between the bowl and the main body is in good condition and does not leak.

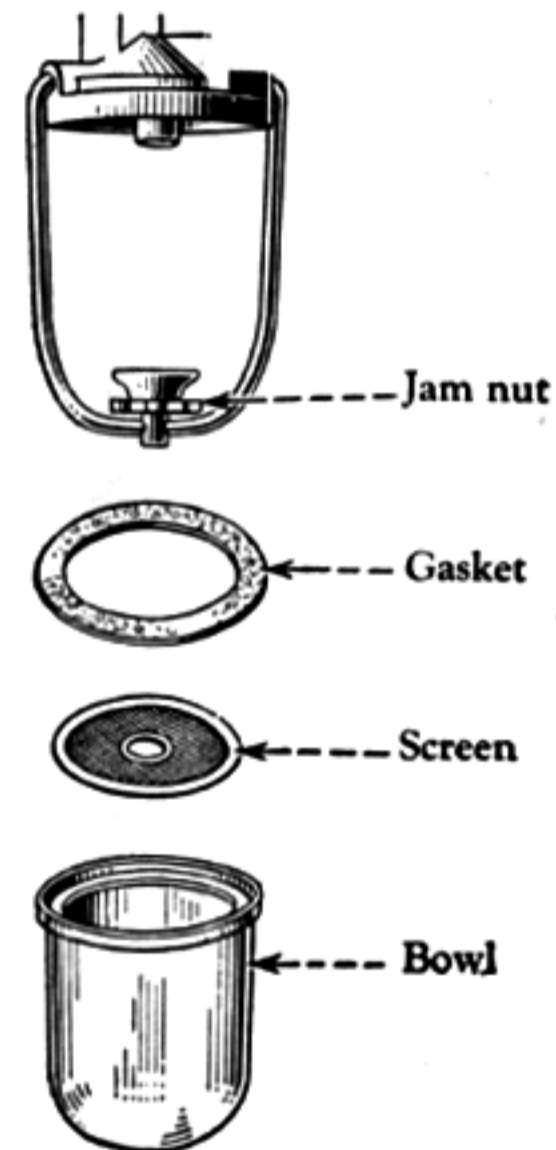

**Illust. 24**  
Fuel Strainer, Showing Glass Bowl Removed for Cleaning.

## COOLING SYSTEM

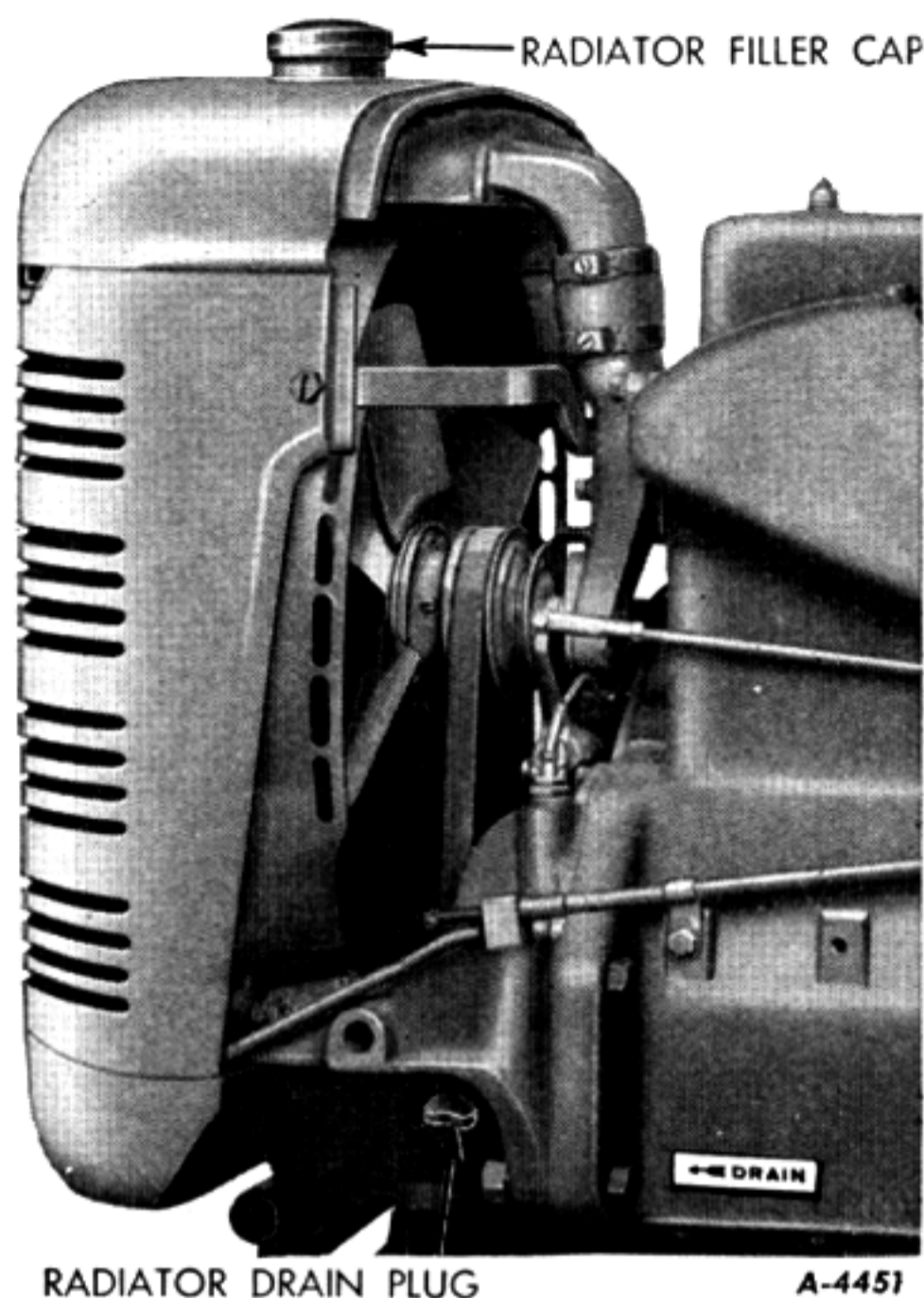

Illustr. 25—Water Cooling System.

The water is circulated through the engine block, cylinder head and radiator by thermo-syphon method. As the engine warms up the water is heated, expands and circulates back through the radiator where the water is cooled before again circulating through the engine.

### To Clean Out Dirt and Sludge

(1) Drain the cooling system by removing the drain plug (*see Illust. 25*). Allow the system to drain and replace the plug.

(2) Fill the cooling system with a solution of 2 pounds of ordinary washing soda mixed with  $3\frac{1}{4}$  U.S. gallons of water (cooling system capacity).

(3) Leave the radiator filler cap off and run the engine until the water is hot, then drain and flush with clean water.

### To Fill Cooling System

(1) The water capacity is approximately  $3\frac{1}{4}$  U.S. gallons.

(2) Replace the drain plug.

(3) Fill radiator to level slightly below bottom of filler neck. Filling the radiator to this level will allow for expansion of the coolant under normal operation conditions.

(4) If the engine becomes overheated, *see "Operating Precautions," page 7.*

(5) If the engine is to be operated in freezing temperatures, *refer to "Cold Weather Operation," page 18.*

### Radiator Core

Overheating is often caused by bent or clogged radiator fins. If the spaces between radiator fins become clogged, clean them with an air or water hose. When straightening bent fins be careful not to injure tubes or break the bond between fins and tubes.

## COOLING SYSTEM—Continued

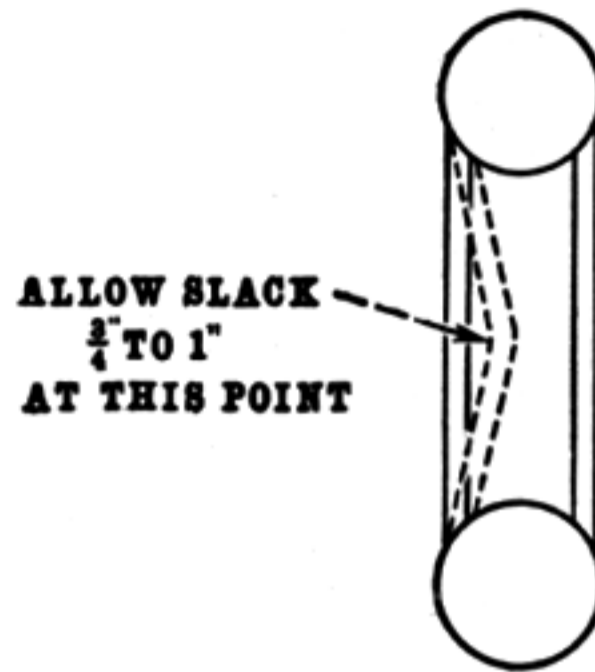

Illust. 26  
Correct Belt Tension.

### Fan Belt Tension

The slack of the fan belt should be checked frequently to assure maintenance of the correct tension. The tension is correct when the belt can be depressed without effort by the thumb, approximately  $\frac{3}{4}$  inch to 1 inch, midway between the two pulleys, *as shown in Illust. 26*. If the slack is more than 1 inch, adjust belt as follows:

### Adjusting the Belt

The tension of the fan belt is adjusted by loosening the fan spindle and moving the spindle up or down until the correct tension is obtained. After obtaining the correct tension, tighten the spindle.

After a new belt has been run approximately 50 hours, check the tension and adjust again if necessary.

### Removing the Fan Belt

To remove fan belt, loosen the fan spindle nut and slide spindle to the bottom of the groove in fan bracket. The fan belt can then be slipped over the bottom drive pulley and worked up over the fan blades.

### Replacing Fan Belt

The fan belt should be replaced when it becomes soaked with grease, or when it is so badly worn that it does not drive the fan at the proper speed.

When replacing the belt, reverse the procedure outlined under "Removing Fan Belt," except that belt can be started on lower pulley by hand, and by slowly cranking the engine, belt will find the correct position.

## VALVE CLEARANCE ADJUSTMENT

Check valve clearance every 400 hours of operation and adjust clearance, if necessary. A clearance of .014 inch is necessary between end of valve levers and valve stems when valves are closed and engine is warm.

(1) Before checking valve clearance, "cut out" the magneto by pulling cable "E" (see *Illust. 18*) out of socket. This will eliminate any danger of accidentally starting the engine.

(2) Remove valve housing.

(3) Remove spark plug from the No. 1 cylinder (the cylinder next to the radiator).

(4) Place thumb over the spark plug opening and slowly crank the engine until an outward pressure can be felt. Pressure indicates No. 1 piston is moving toward upper dead center of the compression stroke.

(5) Continue cranking slowly until the D.C. No. 1 mark on the flywheel is in line with the pointer on the clutch housing cover. (Timing pointer can be seen through opening in bottom of clutch housing—see *Illust. 21*.) Both valves are now closed on compression stroke of No. 1 cylinder.

(6) Loosen the lock nut and adjust screw in valve lever so that gauge slips snugly between end of valve lever and valve stem (see *Illust. 27*).

(7) Tighten lock nut and recheck clearance.

(8) Crank engine  $\frac{1}{2}$  revolution at a time and check clearance of each cylinder's valves and adjust if necessary. Do this on each set of cylinder valves in succession according to the firing order of the engine, which is 1, 3, 4, 2.

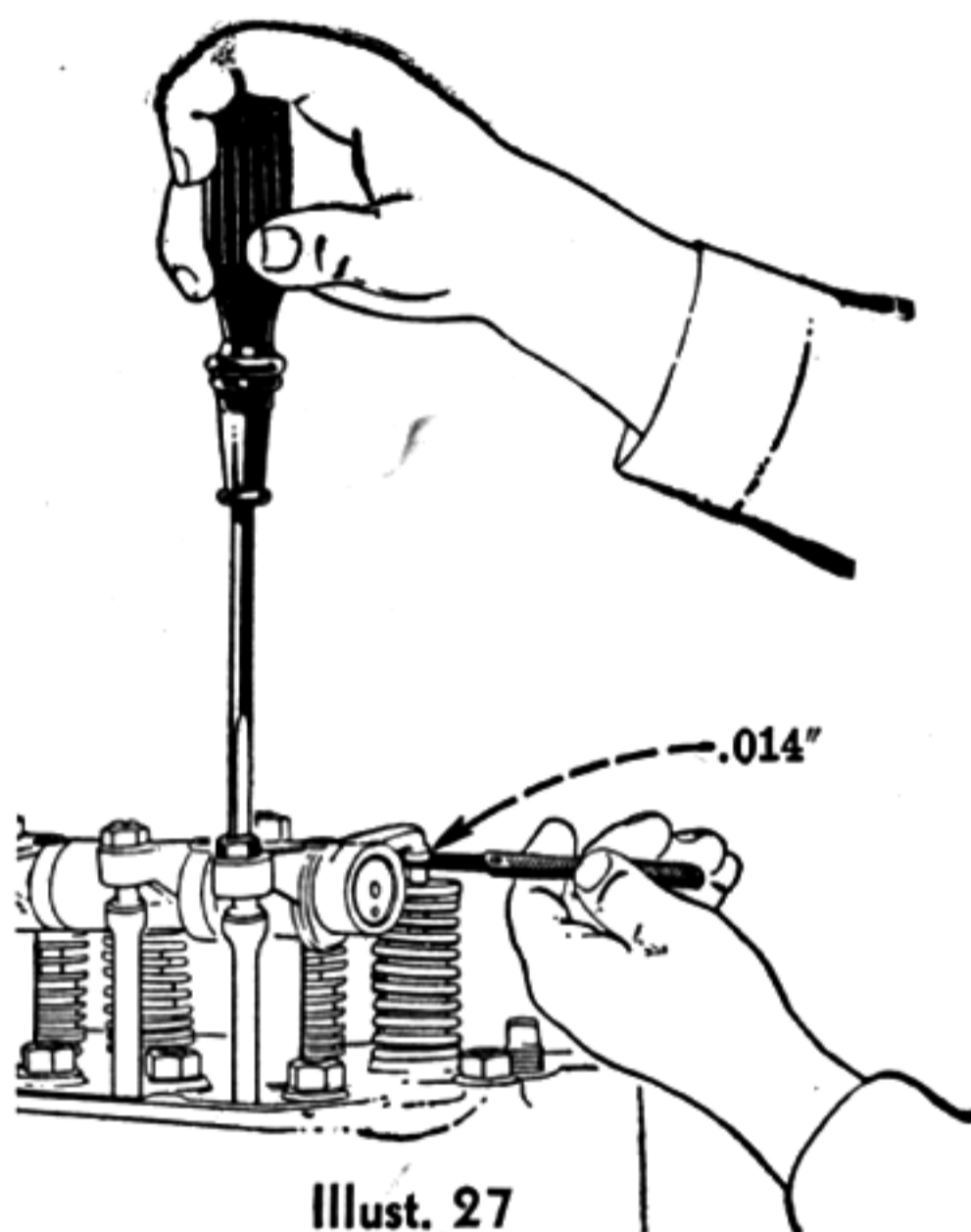

**Illust. 27**  
Gauging Valve Levers with a Feeler Gauge.

(9) Replace the valve housing. Check to see that valve housing gasket makes an oil-tight seal with cylinder head. Use a new gasket if necessary.

(10) Replace the magneto cable "E" (see *Illust. 18*) into socket from which it was removed.

**IMPORTANT!** Be accurate—use a feeler gauge for checking the valve clearance.

# MINOR ENGINE SERVICE OPERATIONS

## Cylinder Head Gasket

For most satisfactory results in tightening cylinder head after installing cylinder head gasket, tighten down all nuts fairly snug, starting with the row in the center, then going to the others. Retighten in the same order, giving each nut a small part of a turn at a time. Continue this until all nuts are tight. Do not screw one nut down perfectly tight and then go to the next, as you will not secure an even pressure on the gasket in this manner.

After replacing cylinder head, it is necessary to insure against leaks by retightening the stud nuts after engine has been run and

water jacket has become thoroughly heated. To tighten nuts properly, the valve rocker shaft assembly must be raised.

**CAUTION!** Be sure to adjust valve tappet clearance after the last tightening of cylinder head stud nuts (see "Valve Clearance Adjustment" on page 35).

## Crankshaft Bearings, Pistons, and Rings

We cannot impress too strongly the necessity of having your International Harvester serviceman do the work on replacement of connecting-rod bearings, crankshaft bearings, pistons and rings, and grinding valves.

# ENGINE CLUTCH

The engine is equipped with a spring-loaded 9-inch diameter, single-plate, dry-disk clutch.

## Care of the Engine Clutch

The clutch is so designed that it requires a minimum of attention. It is important, however, that the clutch release bearing be kept properly lubricated. This can easily be done by following the instructions given in *Lubrication Chart*.

## Clutch Clearance

It is very important that the clutch pedal should have a free movement of 1 inch to  $1\frac{1}{4}$  inches, at which time a clearance of  $\frac{3}{16}$  inch will be maintained between the clutch release bearing and the clutch release levers. As the clutch wears, this free movement decreases and adjustment should be made. Clutch may be badly damaged unless a free movement of foot pedal is maintained. The correct

free movement can easily be maintained by adjusting the length of clutch operating rod. To adjust the length of the rod, loosen and turn nuts on the rear end of clutch operating rod until correct free movement is obtained; then tighten nuts. Nuts on clutch operating rod can be reached through hole in bottom of rear clutch housing tube.

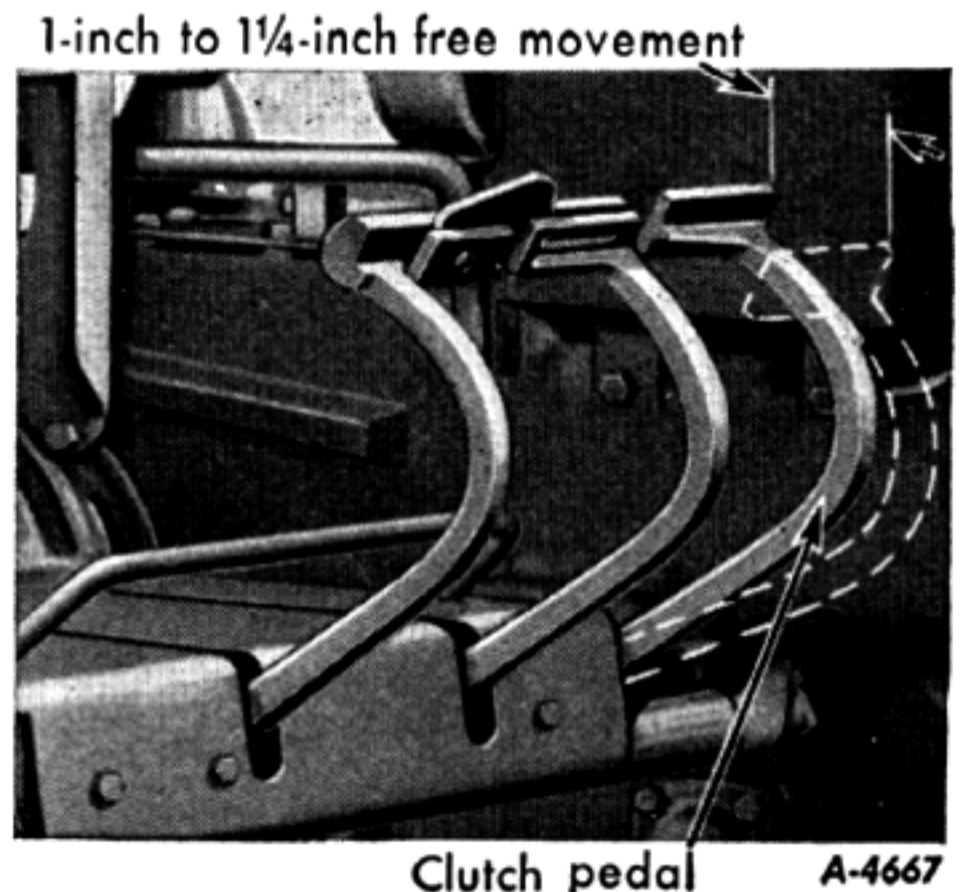

Illust. 28



## BRAKES

The brakes consist of external bands that contract on forged-steel drums. The brakes are controlled by foot pedals which can be operated individually or simultaneously when locked together.

**CAUTION:** *Always lock brake pedals together when traveling in high gear.*

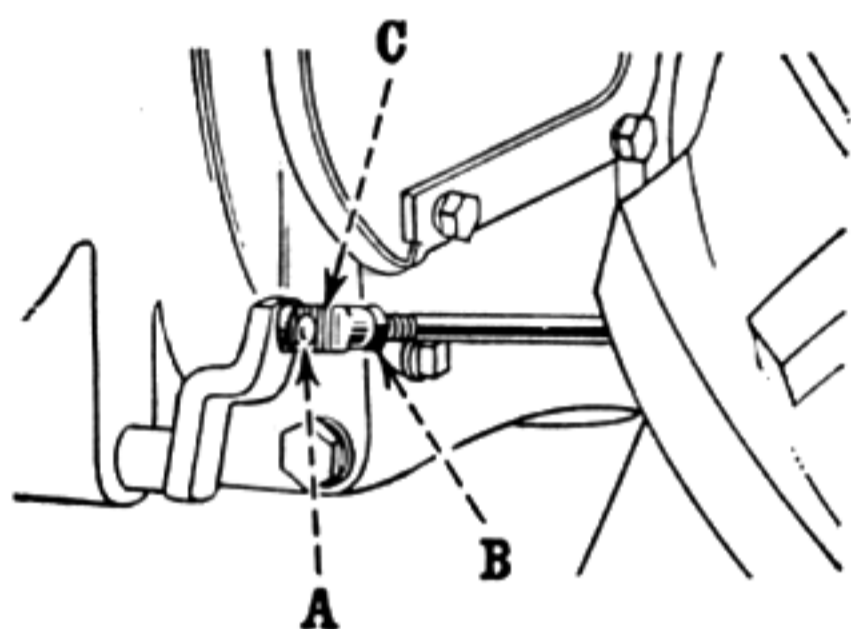

Illust. 29  
Brake Adjustment.

### Adjustment (see Illust. 29)

To adjust the brakes, jack up the rear end

of tractor, remove pin "A" and loosen lock nut "B." Turn the adjusting yoke "C" until each wheel drags slightly.

Replace pin "A" and tighten lock nut "B" after adjustment has been completed.

It is very important that both brake pedals have the same amount of free movement to obtain brake equalization. A definite way to check the equalization of brakes is to jack up both rear wheels so they will turn freely and block tractor securely; then start engine. Operate it either in third or fourth speeds. Application of the brakes should slow down both wheels at the same time and also tend to reduce the speed of the engine. If, when brakes are applied, one wheel stops and the other one continues to revolve, loosen the adjustment on the wheel that stops until both wheels stop simultaneously when the brakes are applied.

## SEAT

The seat on your tractor is adjustable to suit the size and weight of the operator.

### Adjustment

(1) Locate seat for comfort by removing four bolts, "A," holding spring lower support brackets to seat support brackets, and reinstall at desired position.

(2) Adjust springs for flexibility by relocating stop screws "B" under spring leaves at point which gives most comfortable ride. Stop screws should just contact spring with seat in free position.

Be sure stop screws are set in same relation to spring on both sides.

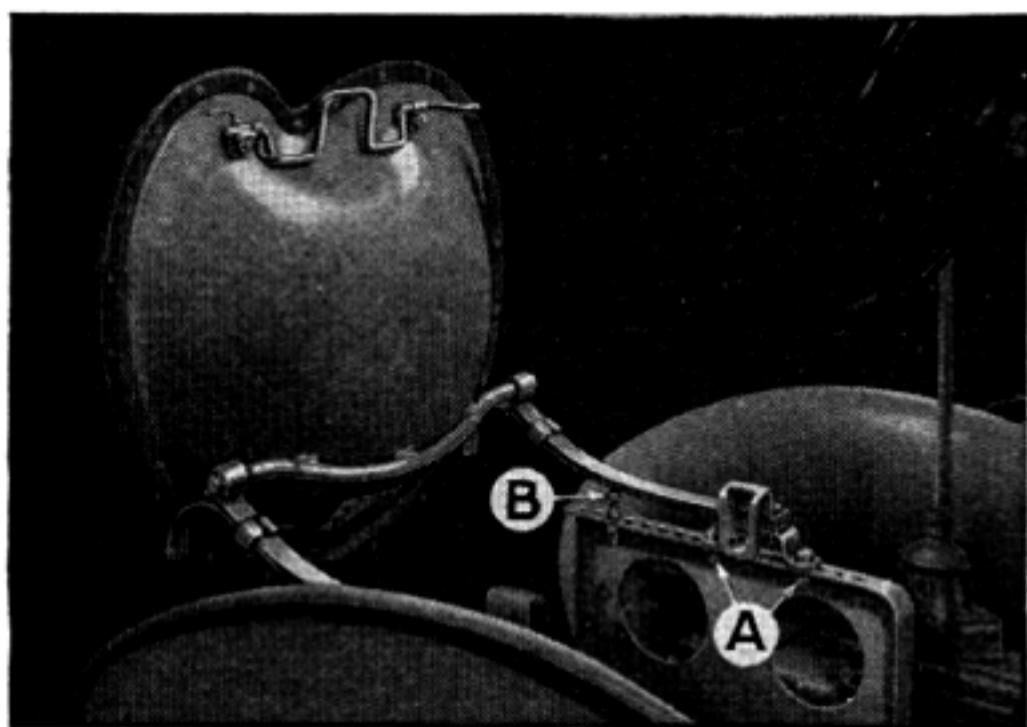

Illust. 30

# DRAWBAR AND HITCH

## WARNING

*Do not attempt to pull when drawbar is removed.*

*Drawbar bolts must be kept tight.*

*All hitches for trailing implements must be attached to the drawbar.*

The tractor exerts its pulling power on pull-behind implements by means of the drawbar which is adjusted up and down to accommodate different hitches. Proper hitching will save both the tractor and the implement it is pulling from undue strains. The hitch should be made so that the center line of pull of the tractor will fall in line with, or be at least near the center line of draft of the hitched-on implement. Hitching to one side or the other of the line of draft will cause stresses and strains on both the tractor and the implement being pulled, frequently great enough to do permanent injury. Incorrect hitching will also tend to make the tractor difficult to steer and will result in unsatisfactory work by the implement being pulled. Make the hitch in such a way that the action of the drawbar pull will neither tend to raise the tractor front wheels from, nor thrust them to the ground as a result of too high or too low hitching.

When using a long chain to hitch tractor to the load, drive the tractor forward, slowly, until all slack is taken out of the chain.

### Adjustment of Farmall-A Drawbar (see *Illust. 31*)

To raise or lower drawbar, loosen bolts "A," remove bolts "B" and move drawbar to desired position. Replace bolts "B" and tighten bolts "A" and "B."

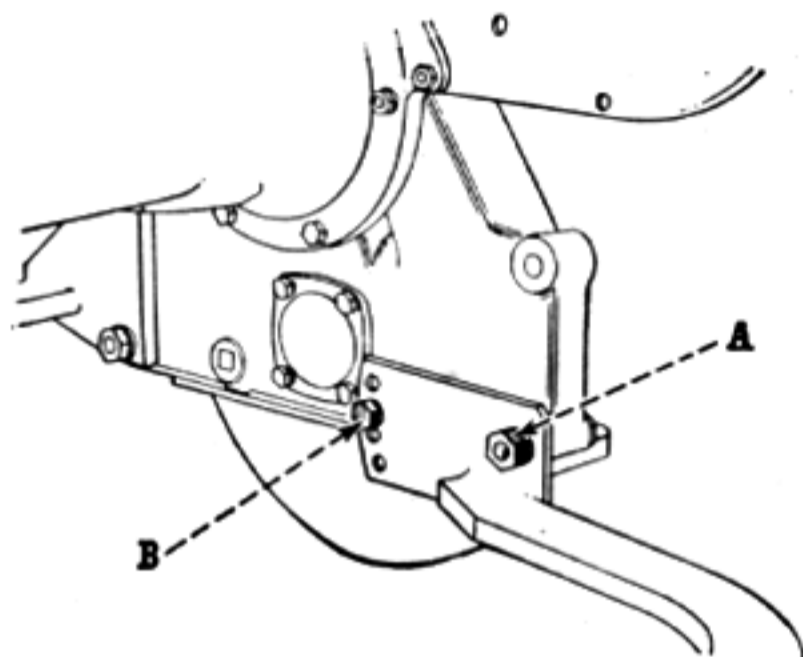

**Illust. 31**

Showing Drawbar Adjustment on Farmall-A Tractors.

### Adjustment of Farmall-AV Drawbar (see *Illust. 32*)

Four positions can be obtained by moving bolts "A" and "B" to desired positions.

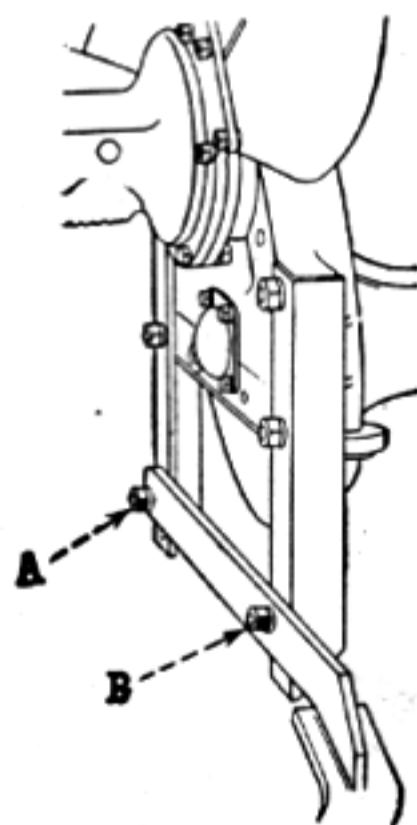

**Illust. 32**

Showing Drawbar Adjustment on Farmall-AV Tractors.

## POWER TAKE-OFF (Furnished When Ordered)

### To Operate Power Take-Off with Tractor in Motion

Disengage the clutch and pull power take-off shifter lever all the way back. Shift transmission to speed desired, then slowly engage the clutch. The power take-off is started and stopped by the same clutch as the tractor; therefore, be sure to disengage clutch before moving the power take-off shifter lever.

**SAFETY FIRST:** *Stop power take-off before dismounting from tractor.*

### To Operate Power Take-Off with Tractor Standing Still

The gearshift lever must be in neutral position.

Disengage the clutch and pull power take-off shifter lever all the way back, then slowly engage clutch.

**NOTE:** *For your own safety, the power take-off exposed shaft should always be covered with a guard.*

## BELT PULLEY (Furnished When Ordered)

The gearshift lever must be in neutral position when operating the belt pulley.

Disengage the clutch and pull the belt pulley shifter lever all the way back, then

slowly engage clutch. The belt pulley is started and stopped by the same clutch as the tractor; therefore, be sure to disengage clutch before moving the pulley shifter lever.

## ADJUSTABLE FRONT AXLES (Furnished on Farmall-A Tractors When Ordered)

### Method of Adjusting

Remove axle extension clamps and remove bolts from tie rod clamps. Then move axle extension so that dowel holes coincide, obtaining desired positions as indicated below. Move tie rod to correspond with position of front axle extension.

Replace axle extension clamps and replace bolts in tie rod clamps and tighten.

Six adjustments can be obtained at 4-inch increments, which will give the following treads—44, 48, 52, 56, 60 and 64 inches, which will track accurately with the rear wheels.

## POWER TAKE-OFF (Furnished When Ordered)

### To Operate Power Take-Off with Tractor in Motion

Disengage the clutch and pull power take-off shifter lever all the way back. Shift transmission to speed desired, then slowly engage the clutch. The power take-off is started and stopped by the same clutch as the tractor; therefore, be sure to disengage clutch before moving the power take-off shifter lever.

**SAFETY FIRST:** *Stop power take-off before dismounting from tractor.*

### To Operate Power Take-Off with Tractor Standing Still

The gearshift lever must be in neutral position.

Disengage the clutch and pull power take-off shifter lever all the way back, then slowly engage clutch.

**NOTE:** *For your own safety, the power take-off exposed shaft should always be covered with a guard.*

## BELT PULLEY (Furnished When Ordered)

The gearshift lever must be in neutral position when operating the belt pulley.

Disengage the clutch and pull the belt pulley shifter lever all the way back, then

slowly engage clutch. The belt pulley is started and stopped by the same clutch as the tractor; therefore, be sure to disengage clutch before moving the pulley shifter lever.

## ADJUSTABLE FRONT AXLES (Furnished on Farmall-A Tractors When Ordered)

### Method of Adjusting

Remove axle extension clamps and remove bolts from tie rod clamps. Then move axle extension so that dowel holes coincide, obtaining desired positions as indicated below. Move tie rod to correspond with position of front axle extension.

Replace axle extension clamps and replace bolts in tie rod clamps and tighten.

Six adjustments can be obtained at 4-inch increments, which will give the following treads—44, 48, 52, 56, 60 and 64 inches, which will track accurately with the rear wheels.

# METHOD OF OBTAINING FARMALL-A REAR WHEEL TREADS OF 40, 44, 48, 52, 56, 60, 64 and 68 INCHES

Eight adjustments at 4-inch increments can be obtained by means of attaching the rim in 4 different positions on wheel combined with 2 positions of wheel on hub as shown in *Illust. 36*.

**NOTE:** When rims are reversed, change the tire and rim assembly, putting right-hand tire and rim on left-hand side and

vice versa, in order to keep tread of tire pointing in the correct direction of rotation as shown by arrow on tire.

When assembling the rear wheel rim be sure to use washer in assembly and tighten clamp bolts securely.

**CAUTION:** Do not attempt to put right-hand (cast iron) wheel on left-hand side.

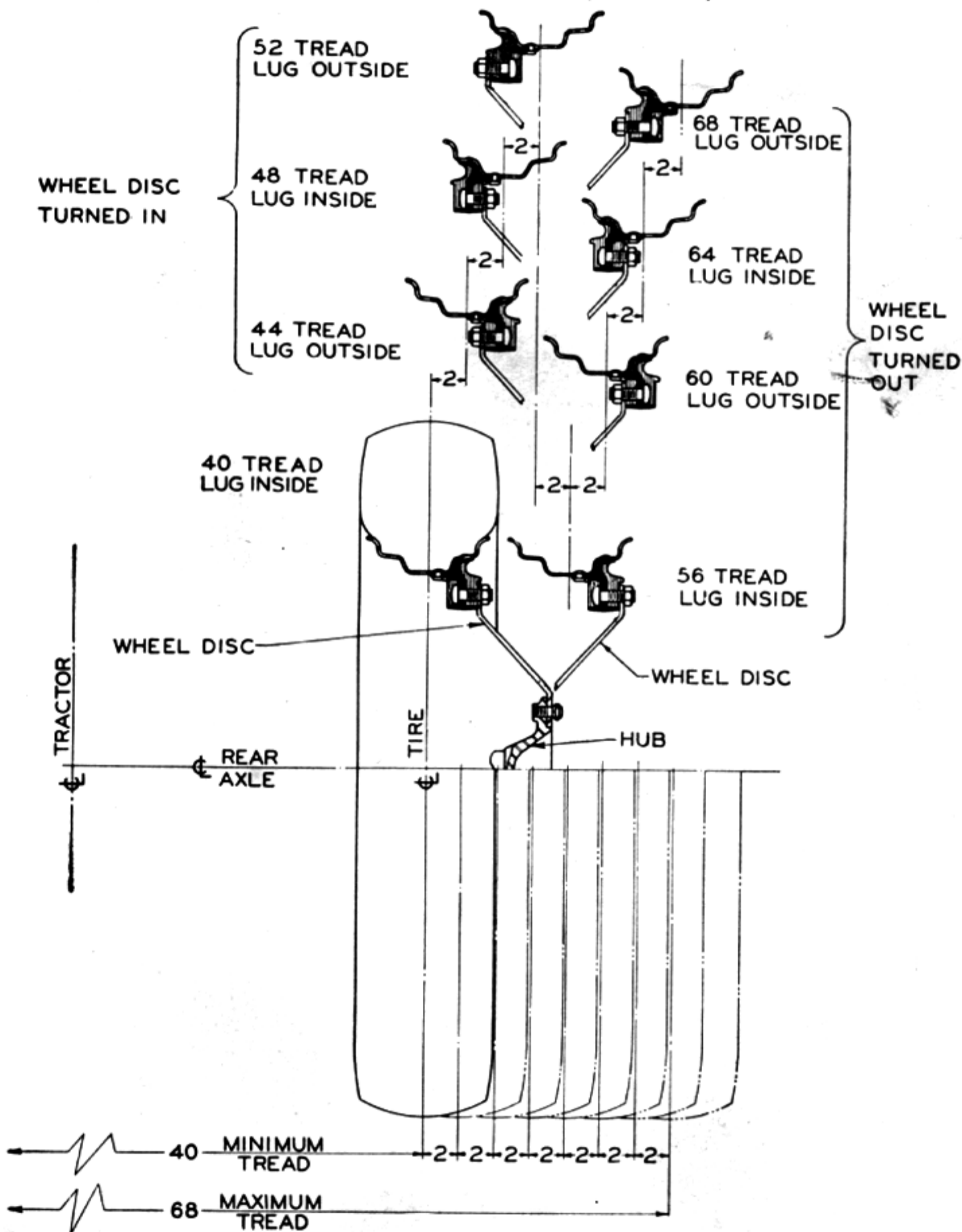

Illust. 36

**NOTE:** All dimensions shown are in inches.

# METHOD OF OBTAINING FARMALL-AV REAR WHEEL TREADS OF 48, 52, 56, 60, 64 and 68 INCHES

Adjustments from 48 to 68 inches at 4-inch increments can be obtained by attaching the rim in the different positions on disc, with disc turned in or out as shown on illustration.

**NOTE:** When rims are reversed, change the tire and rim assembly, assembling

right-hand tire and rim on left-hand side and vice versa, in order to keep tread of tire pointing in the correct direction of rotation as shown by arrow on tire.

When assembling rear wheel rim be sure to use washer in assembly and tighten clamp bolts securely.

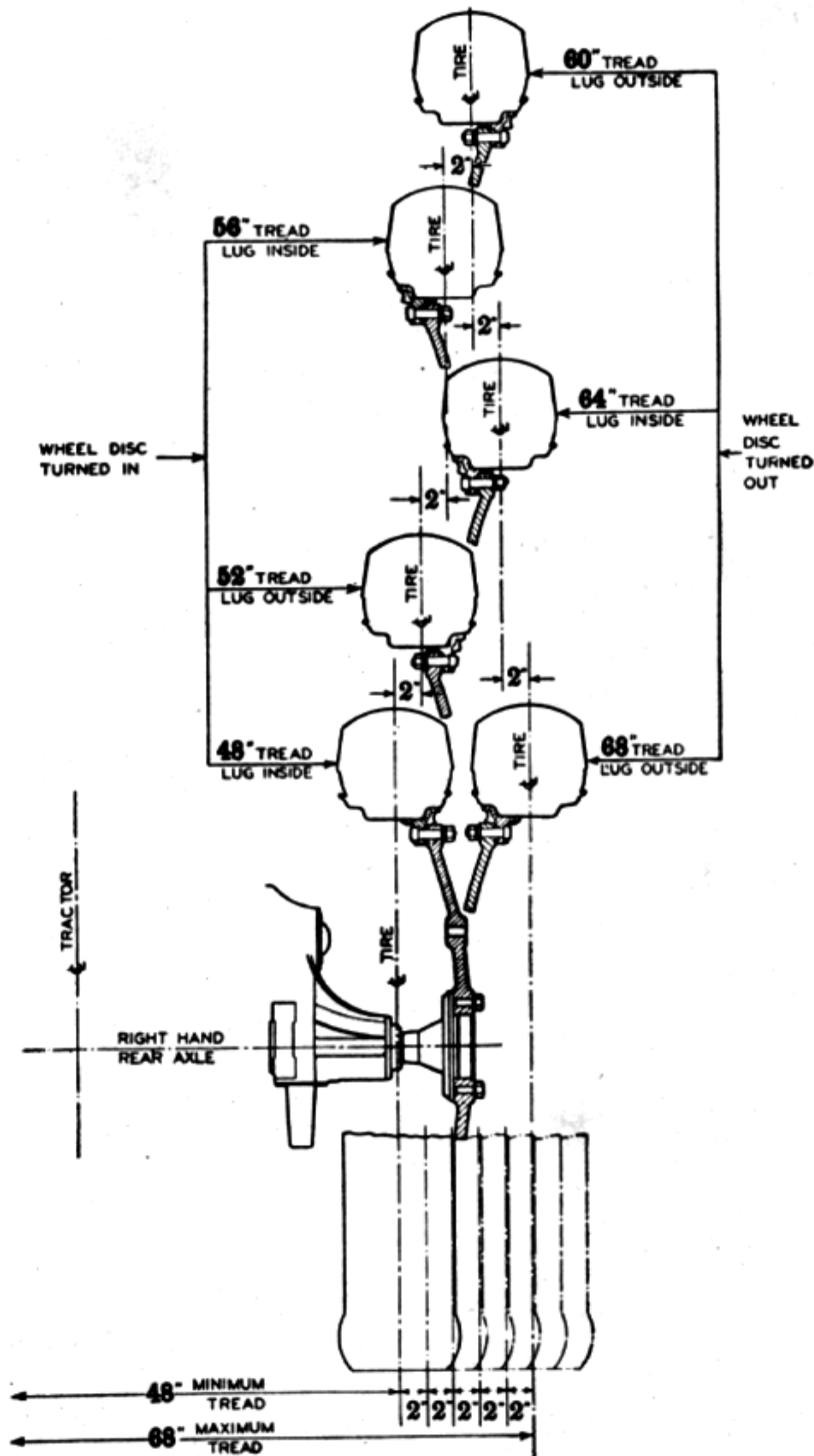

Illust. 37

## METHOD OF OBTAINING FARMALL-AV FRONT WHEEL TREADS OF 44, 48, 52, 56, 60, 64 and 68 INCHES

Adjustment of front wheel treads from 44 to 68 inches at 4-inch increments can be obtained. Beginning with front wheels in minimum tread position, adjustments to 64 inches can be obtained as shown at "A" on illustration. For maximum tread

position (68 inches) reverse rim and reassemble as shown at "B."

When assembling the front wheel rim be sure to use water in assembly and tighten clamp bolts securely.

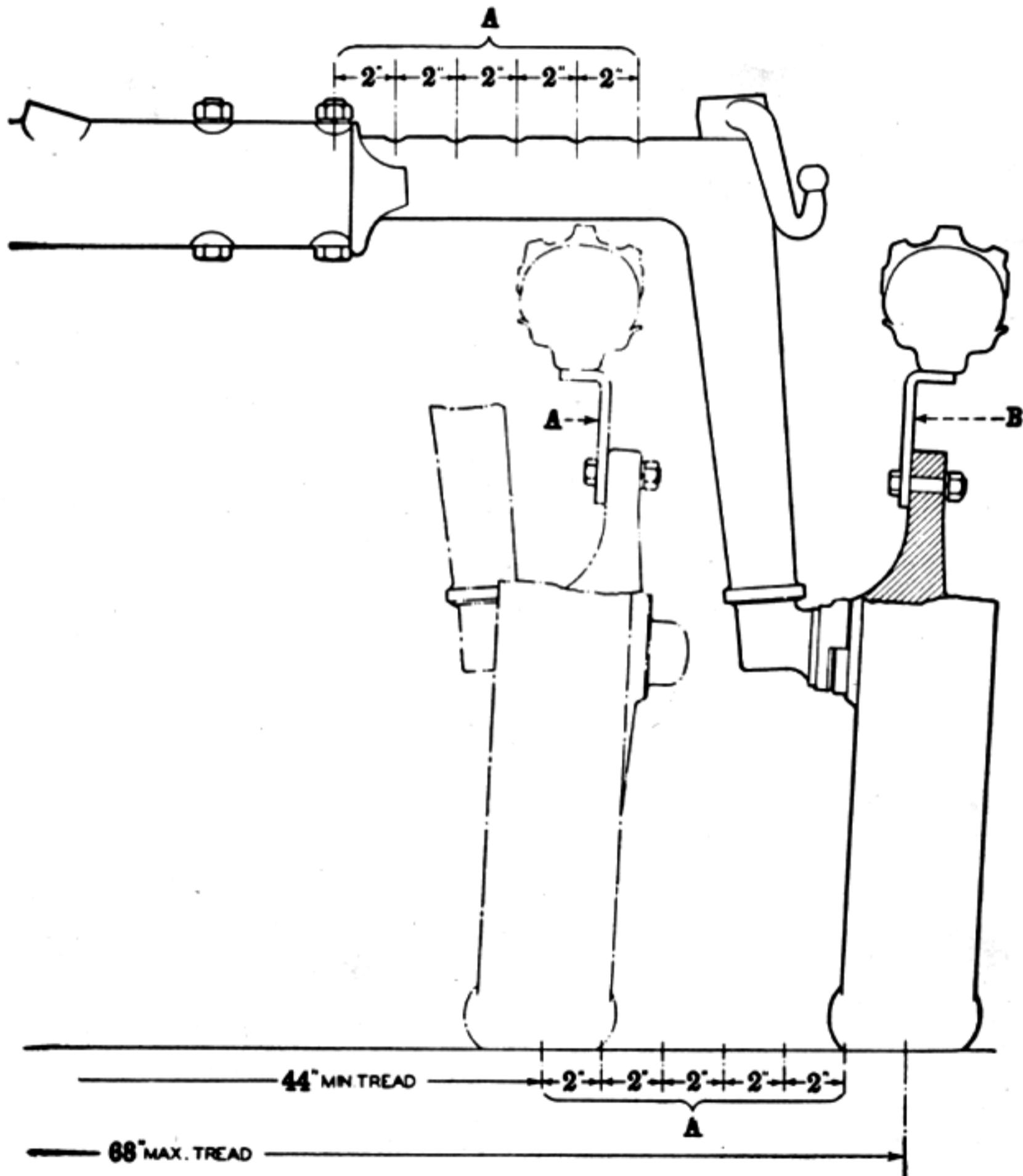

Illust. 38

## PNEUMATIC TIRES

The instructions and recommendations shown below should be followed in order to secure maximum life and efficient service from pneumatic tires.

### Inflation

To secure maximum life and satisfactory performance from pneumatic tires, keep them properly inflated to the pressures shown under heading "Operating Pressure for Low-Pressure Tractor Tires." Under-inflation will damage tire cord body and may cause tire to slip on the rim and tear out the tube valve stem. Over-inflation results in excessive slippage, causing rapid tire wear.

Air pressure should be checked once a week with an accurate low-pressure gauge having one pound graduations. Air pressure should not be allowed to drop below the recommendations.

Tires can be inflated with a pressure pump, hand pump, or a spark plug pump. Spark plug pumps can be secured from International Harvester dealers.

Always see that tire valve caps are in place and screwed tight. The caps prevent the loss of air through the valve core, and also prevent loose soil, mud, gravel, snow, and ice from entering and damaging the valve core and air chamber in tires.

### OPERATING PRESSURE FOR LOW-PRESSURE TRACTOR TIRES

**CAUTION:** Adjust air pressure in tires as indicated below immediately upon receiving this tractor.

FRONT AND REAR TIRES	Lbs. Per Sq. In.	KG/CM <sup>2</sup>
<b>FRONT (All Sizes)</b>		
A—4-Ply Tires.....	28	1.97
B—6-Ply Tires.....	36	2.53
<b>REAR</b>		
<b>C—MINIMUM INFLATION PRESSURE, 4 AND 6-PLY TIRES</b>		
4, 5, 6, 7 Duals.....	20	1.40
All other sizes.....	12	.84
D—When plowing, increase pressure in tire on furrow wheel by	4	.28
E—When special heavy wheels are used, or heavy implements such as corn pickers, bedders, etc., are carried on the tractor, inflation pressure must be increased. See tire and rim association schedule or contact the tractor dealer or manufacturer.		
<b>F—MAXIMUM INFLATION PRESSURE, 4-PLY TIRES</b>		
*—4, 5, 6, 7 Duals.....	24	1.68
All other sizes.....	16	1.12
<b>G—MAXIMUM INFLATION PRESSURE, 6-PLY TIRES</b>		
All sizes .....	24	1.68
* —Made only in 4 plies.		



# WAR QUALITY FARM TIRES

- (1) Use these tires with extreme care.
- (2) They are of war quality materials as stipulated by government regulations.
- (3) To insure the maximum hours of service, watch the tread lugs—if they wear down too fast, immediately add more weight to cut down slippage.
- (4) Keep tractor tires properly inflated—28 pounds in front and 12 pounds in rear tires except when plowing. Then furrow wheel tire should be inflated to 16 pounds. Do not over-inflate as this will result in fast tread wear. Be sure to reduce high shipping pressures.
- (5) Maintain inflation pressure in implement tires as shown in instruction book.
- (6) When not in use the tractor or implement should be stored so that the tires are protected from the light.
- (7) If not in use for long periods, store tractor or implement so that load is off tires.
- (8) For certain severe operating conditions it may be advisable to use steel wheels for the duration.
- (9) Avoid stumps, stones, deep ruts and other hazards.
- (10) Do not load these tires beyond their rated capacity.
- (11) Maximum speed for highway use should not exceed 20 M.P.H. For farming operations a maximum speed of 10 M.P.H. is recommended.

---

## INTERNATIONAL HARVESTER COMPANY

180 NORTH MICHIGAN AVE.

CHICAGO 1, ILLINOIS, U.S.A.

## PNEUMATIC TIRES—Continued

### Shipping Tractors with Pneumatic Tires

When tractors are transported on a carrier, such as railroad cars or trailers, inflation pressures should be as follows to make possible rigid blocking and to prevent bouncing:

All 4-ply front tires.....	30 lbs.
All 6-ply front tires.....	36 lbs.
All rear tires.....	30 lbs.

**IMPORTANT!** Tires should be deflated to correct operating pressure before tractor is transported under its own power, towed, put into service, or placed in storage for any length of time, otherwise the rubber will check or crack.

When towing tractors, do not exceed a speed of 20 M.P.H.

### Mounting Tires on the Rim

After mounting a new or old tire on rim, inflate it to 30-lb. pressure to seat the tire bead on rim flange and to prevent tire from creeping and shearing off the valve. Then deflate or inflate tire to correct operating pressure.

### Traction and Weights

The recommended air pressures *are shown on page 44*. Tractor should not be operated with tires improperly inflated. If more traction is required use additional weight and check for high air pressure. (See *International Harvester dealer for information*.)

### Wheel Weights

The drawbar pull of a tractor can be increased by the addition of weight to the driving wheels, either by adding cast iron weights to the wheels, or by the use of liquid in the tube.

The amount of the increase in drawbar pull by the addition of certain definite weights varies with the type of soil. When very heavy weight is required, both liquid and cast iron weights can be used.

### Caution: Overloading

In adding weights, consideration must be given so as not to exceed the load capacity of the tire.

After adding weight to the rear wheel it may be necessary to readjust the height of drawbar to get the correct alignment.

### Liquid Weight

Tractor tire tubes can be filled  $\frac{3}{4}$  full with liquid, using clean water for temperatures above freezing (32° F.). A calcium chloride solution (Ca Cl<sub>2</sub>) is recommended when operating in freezing temperatures.

### Methods of Putting Liquid into Tube

Secure an adapter *as shown in Illust. 39* from an International Harvester dealer. The adapter is provided with a bleeder for letting out the air displaced by the liquid.

Jack up the tractor and revolve tire so valve stem is on top. Remove valve core housing and screw on adapter, then attach water hose to adapter.

The liquid can be put into the tube from a tank placed at least five feet higher than the tire, by using a hand force pump or by using compressed air and a pressure tank filled with liquid.

## PNEUMATIC TIRES—Continued

Remove hose and adapter, then replace valve core housing and inflate tire to correct operating pressure.

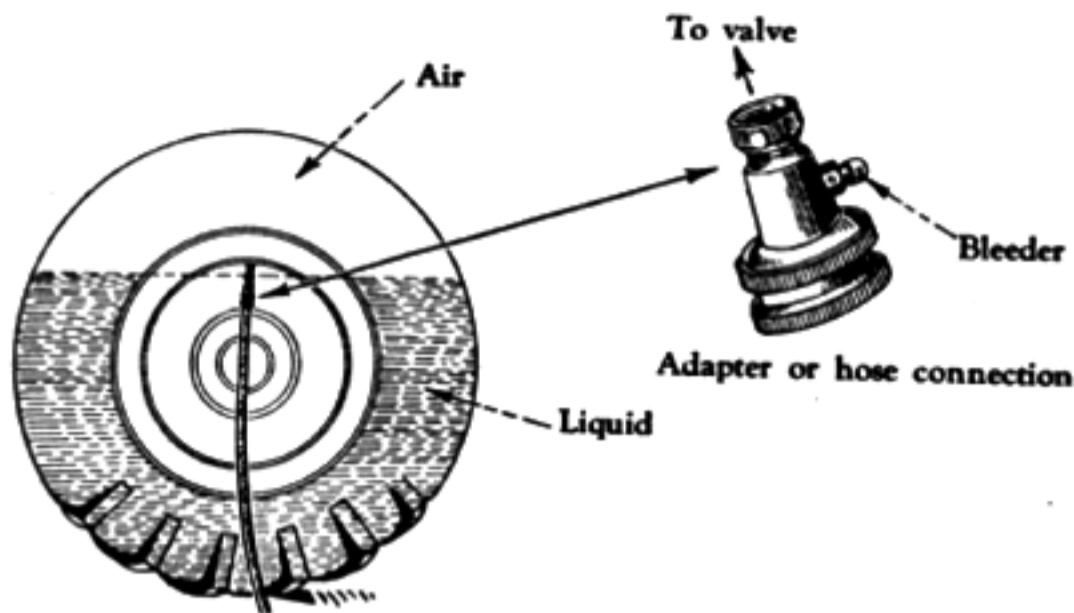

Illust. 39  
Tires Three-quarters Full of Liquid.

### Liquid Weight for Freezing Temperatures

Calcium chloride solution, using a 25% mixture, which is approximately 20 lb. of flaked calcium chloride to 10 U.S. gallons of water, is recommended when freezing temperatures prevail.

The strength of the solution can be checked with a battery hydrometer. A 25% solution measures approximately 1.225 specific gravity and has a freezing point of 25° below zero.

**CAUTION:** Some calcium chloride flakes have an acid reaction. It is advisable to add one pound of lime to each 100 pounds of calcium chloride used.

When preparing calcium chloride solution, always pour the water into the container first, then add the correct amount of calcium chloride crystals, stirring the mixture thoroughly. Never pour the water on the calcium chloride flakes. After the solution is mixed, allow it to cool before using.

Never use calcium chloride in cooling system.

### Valve Stem Mounting Cones

Valve stem mounting cones are furnished with all rear wheel tire tubes having valve stem for inserting liquids, and are mounted on the valve stem at the factory.

The purpose of the cone is to hold the valve stem in the valve hole when mounting tire, particularly when liquid is used in the tire. Without the cone, when mounting the tire or inserting the liquid, the valve stem is very apt to be pulled into the rim and will entail much extra work in again getting it through the valve hole.

### Care of Tires

Cuts in tires should be repaired immediately as neglect decreases the tire life.

Keep tires free from oil and grease as both destroy rubber.

After using tractor for spraying—insect control work—wash off with water any chemicals that may be on the tires.

### Tire Protection During Storage

Before storing tractor, clean the tires thoroughly. Jack up tractor when it is to be out of service for a long period. If it is not jacked up, tires should be inflated at regular intervals. Before putting tractor in service, always inflate tires to correct operating pressures.

### Tire Chains

For wet grass or ground conditions, use lug type chains. The flexing of the tire and creeping of chains will break the mud loose as wheel rotates.

*There is a possibility of the tire slipping within the chain; to prevent this, the use of spring type chain fasteners is recommended.*

### Static Electricity in Tractors Equipped with Pneumatic Tires Doing Belt Work

Static electricity generated by belt work can be discharged harmlessly by attaching a chain to the tractor and letting it touch the ground.

# SUGGESTIONS FOR CHECKING TROUBLE

## Study the Problem Before Making Any Changes

If any adjustments are to be disturbed, the original setting should be noted, so that this same setting may be restored in case the new adjustment does not remedy the trouble.

### Failure To Start:

- No gasoline in carburetor.
- Fuel valve closed.
- Carburetor choked too much.
- Magneto grounded.
- Engine speed control lever not advanced.
- Gears engaged.
- Distillate instead of gasoline in carburetor (for starting).

### Irregular Speed:

- Governor sticking, out of adjustment, or worn.
- Throttle shaft bent or out of alignment.

### Lack of Power:

- Governor out of adjustment.
- Exhaust pipe clogged.
- Engine speed control lever not advanced.
- Clutch slipping.
- Air cleaner pipe clogged.

### Overheating:

- Insufficient amount of water.
- Fan belt slipping.
- Excess load.
- Inside of radiator and cylinder block limed up or clogged with dirt.
- Outside of radiator or radiator screen covered with dirt or chaff.
- Excess carbon in the cylinders.
- Carburetor improperly adjusted.

### Missing and Backfiring:

- Water in the fuel.
- Air leaks around the intake manifold.
- Engine not warmed up.
- Red-hot carbon deposits in cylinder.

### Lack of Oil Pressure:

- Insufficient amount of oil.
- Oil diluted or not as specified.
- Dirt under the oil pressure regulating valve.
- Defective oil pressure indicator.
- Oil pump strainer clogged or pump not working.

### Knocking:

- Excess carbon in the cylinders.
- Sticky valve or improperly adjusted valves.
- Loose piston pin, connecting rod, camshaft, or crankshaft bearings.
- Broken piston rings or loose pistons.

### Lack of Compression:

- Sticky, dirty, pitted or improperly adjusted valves.
- Stuck, worn or broken piston rings.
- Worn pistons.
- Leaky cylinder head gasket.

### Excess Fuel Consumption:

- Choke closed.
- Air intake cap or air cleaner clogged.
- Incorrect amount or improper grade of oil.
- Leaky carburetor fuel valve.
- Carburetor adjustment too rich.

### Lack of Fuel:

- Fuel low in the tank.
- Air vent hole in fuel tank filler cap plugged.
- Fuel valve closed or only partially opened.
- Clogged fuel strainer screen, fuel line or carburetor strainer.

### Defective Ignition:

- Wrong kind, old, cracked, dirty or poorly set spark plugs.
- Broken, loose or improperly connected wiring.
- Dirty distributor block disk.
- Stuck or broken distributor brush in magneto.
- Dirty, pitted, or improperly set breaker points.
- Breaker arm not free on its bearing or the breaker arm spring weak or broken.
- Magneto not timed correctly with the engine.
- Impulse coupling dirty, dry or lubricated with heavy oil.

Explosions in exhaust pipe often occur just after starting, due to first charges not firing in cylinder and passing through into exhaust pipe, where burning gases from first few explosions will ignite them.

# STORING AND HOUSING TRACTORS

When your tractor is not to be used for a period of time, it should be stored in a dry and protected place. To leave equipment outdoors, exposed to the elements, will result in materially shortening the life of the machine.

The following procedure should be followed when your tractor is placed in storage and the lubrication precautions should be repeated every six months thereafter. We also recommend caution to be practiced in starting an engine that has been in storage (*see instructions on the bottom of the page*).

1. Wash or clean and completely lubricate the tractor (*refer to Lubrication Chart*).
2. Drain water from the cooling system.
3. Oil magneto impulse coupling liberally with light oil such as cream separator or sewing machine oil.
4. After the engine has become cold, remove the spark plugs and pour one tablespoonful of SAE-50 lubricating oil of a good grade into each cylinder. Crank engine 2 or 3 times to distribute oil over the cylinder walls.
5. Remove valve housing cover and flush valves, rocker arms, and push rods with SAE-50 oil. (If any evidence of rust is found, remove it before lubricating.) Replace valve housing cover.
6. Plug up the ends of breather pipe and exhaust pipe.
7. Remove the oil filter element. (If any evidence of rust is found on the center stud, clean thoroughly.) Replace filter element with new and drain out any sludge from filter base.
8. Drain fuel from fuel tank and carburetor and clean out fuel strainer glass bowl. **CAUTION:** A gummy substance will form in gasoline if allowed to stand in tanks, fuel lines or carburetor. This gum accumulates in the carburetor jets and passages, causing serious trouble.

These gum deposits can be completely dissolved with a mixture of 1 part alcohol and 1 part benzol, or with acetone.

## STARTING ENGINES THAT HAVE BEEN IN STORAGE

1. Remove spark plugs and pour a mixture of one-half gasoline and one-half light lubricating oil into each cylinder (two tablespoonfuls per cylinder is enough).
2. Remove valve housing cover and flush valve and valve operating mechanism with the same mixture.
3. Crank engine rapidly until excess oil has been blown out of spark plug holes. This operation will loosen any tight piston rings and wash old gummy oil from valves and pistons.
4. Flush out impulse coupling with kerosene and lubricate as specified.
5. Flush out crankcase with kerosene and fill with specified lubricating oil. (*See "Lubrication Chart."*)
6. Be sure filter has a new element before starting engine.
7. Remove crankcase breather pipe plug, and exhaust pipe plug.
8. Install spark plugs.
9. Fill water cooling system.
10. Fill fuel tanks.
11. Start engine and let run slowly; observe if any valves are sticking. If so, pour small quantity of kerosene on valve stem until loose.
12. Assemble valve housing cover.

**CAUTION!** Do not accelerate the engine rapidly or operate at high speed immediately after starting.

# SPECIFICATIONS

## TRACTOR USED ON

### Capacities U. S. Measure

Gasoline tank (when operating on Distillate).....	
Fuel tank.....	
Water cooling system.....	
Crankcase pan.....	
Transmission case (less power take-off or belt pulley).....	
Transmission case and power take-off.....	
Transmission case and belt pulley.....	
<i>*The belt pulley housing has a 3/4-pt. capacity. This, however, does not have to be replenished every time the transmission is drained. If the belt pulley housing has been drained, add an additional 3/4 pt. to the transmission.</i>	
Steering gear housing.....	
Rear axle drive housing (each).....	
Air cleaner oil cup.....	

Farmall-A	Farmall-AV
Approx. 1 gal.	Approx. 1 gal.
Approx. 10 gals.	Approx. 10 gals.
Approx. 3 1/4 gals.	Approx. 3 1/4 gals.
Approx. 5 qts.	Approx. 5 qts.
Approx. 4 1/2 qts.	Approx. 5 qts.
Approx. 5 qts.	Approx. 5 1/2 qts.
*Approx. 5 qts.	*Approx. 5 1/2 qts.
Approx. 1 qt.	Approx. 1 qt.
Approx. 3 pts.	Approx. 3 pts.
3/4 pt.	3/4 pt.

### Engine

Cylinders.....
Bore.....
Stroke.....
Engine speed (governed) (maximum full load).....
**Power take-off shaft speed.....
Magneto (fixed spark) (clockwise rotation).....
Spark plug gap.....
Valve clearance (engine hot).....
Carburetor (with Donaldson Air Cleaner).....

4	4
3 in.	3 in.
4 in.	4 in.
1400 R.P.M.	1400 R.P.M.
541 R.P.M.	541 R.P.M.
IHC Type H-4	IHC Type H-4
.028 to .032 in.	.028 to .032 in.
.014 in.	.014 in.
Zenith	Zenith

### Clutch and Belt Pulley

Single-plate, dry-disk (spring-loaded).....
**Pulley speed.....
**Belt speed (with 8 1/2 in. pulley).....
**Pulley diameter.....
**Pulley face.....

9 in.	9 in.
1157 R.P.M.	1157 R.P.M.
2574 ft. per min.	2574 ft. per min.
8 1/2 in.	8 1/2 in.
6 in.	6 in.

### Foot Brakes

External contracting on drums

### Transmission (Four-Speed)

(Speed is based on pneumatic tire sizes).....																
Speed (miles per hour).....	<table border="0"> <tr> <td>1st.....</td> <td>2 1/4</td> <td>2 7/8</td> </tr> <tr> <td>2nd.....</td> <td>3 1/2</td> <td>4 5/8</td> </tr> <tr> <td>3rd.....</td> <td>4 5/8</td> <td>6 1/8</td> </tr> <tr> <td>High.....</td> <td>9 5/8</td> <td>12 3/4</td> </tr> <tr> <td>Reverse.....</td> <td>2 3/4</td> <td>3 5/8</td> </tr> </table>	1st.....	2 1/4	2 7/8	2nd.....	3 1/2	4 5/8	3rd.....	4 5/8	6 1/8	High.....	9 5/8	12 3/4	Reverse.....	2 3/4	3 5/8
1st.....	2 1/4	2 7/8														
2nd.....	3 1/2	4 5/8														
3rd.....	4 5/8	6 1/8														
High.....	9 5/8	12 3/4														
Reverse.....	2 3/4	3 5/8														

8 x 24 in.	8 x 36 in.
2 1/4	2 7/8
3 1/2	4 5/8
4 5/8	6 1/8
9 5/8	12 3/4
2 3/4	3 5/8

### Wheels and Tread

Front wheels (for pneumatic tires).....
Rear wheels (for pneumatic tires).....
Wheelbase.....
Tread, front (standard—fixed).....
†Tread, front (adjustable front axle).....
Tread, rear.....

4.00 x 15 in.	4.00 x 19 in.
8 x 24 in.	8 x 36 in.
71 in.	71 1/4 in.
43 in.	.....
44 to 64 in.	44 to 68 in.
40 to 68 in.	48 to 68 in.

### General Dimensions

Length (over-all).....
Width (over-all) minimum treads.....
Width (over-all) maximum treads.....
Height (over-all) (steering wheel).....
Drawbar (adjustable) { Height.....
{ Vertical adjustment.....
{ Lateral adjustment.....
Ground clearance for crops { under front axle.....
{ under rear axle.....
Turning radius with minimum treads { without brake applied..
{ with brake applied.....

106 in.	114 7/8 in.
55 7/8 in.	60 5/8 in.
76 3/4 in.	76 3/8 in.
63 1/4 in.	69 1/4 in.
14 3/8 in.	14 in.
10 3/8 to 16 1/2 in.	11 7/8 to 17 3/4 in.
9 1/2 to each side of center hole	9 1/2 to each side of center hole
21 7/8 in.	27 in.
20 7/8 in.	26 7/8 in.
9 3/4 ft.	9 1/4 ft.
9 ft.	8 3/4 ft.

\*\*—Special (furnished when ordered)

†—Special on Farmall-A

# For Your Protection

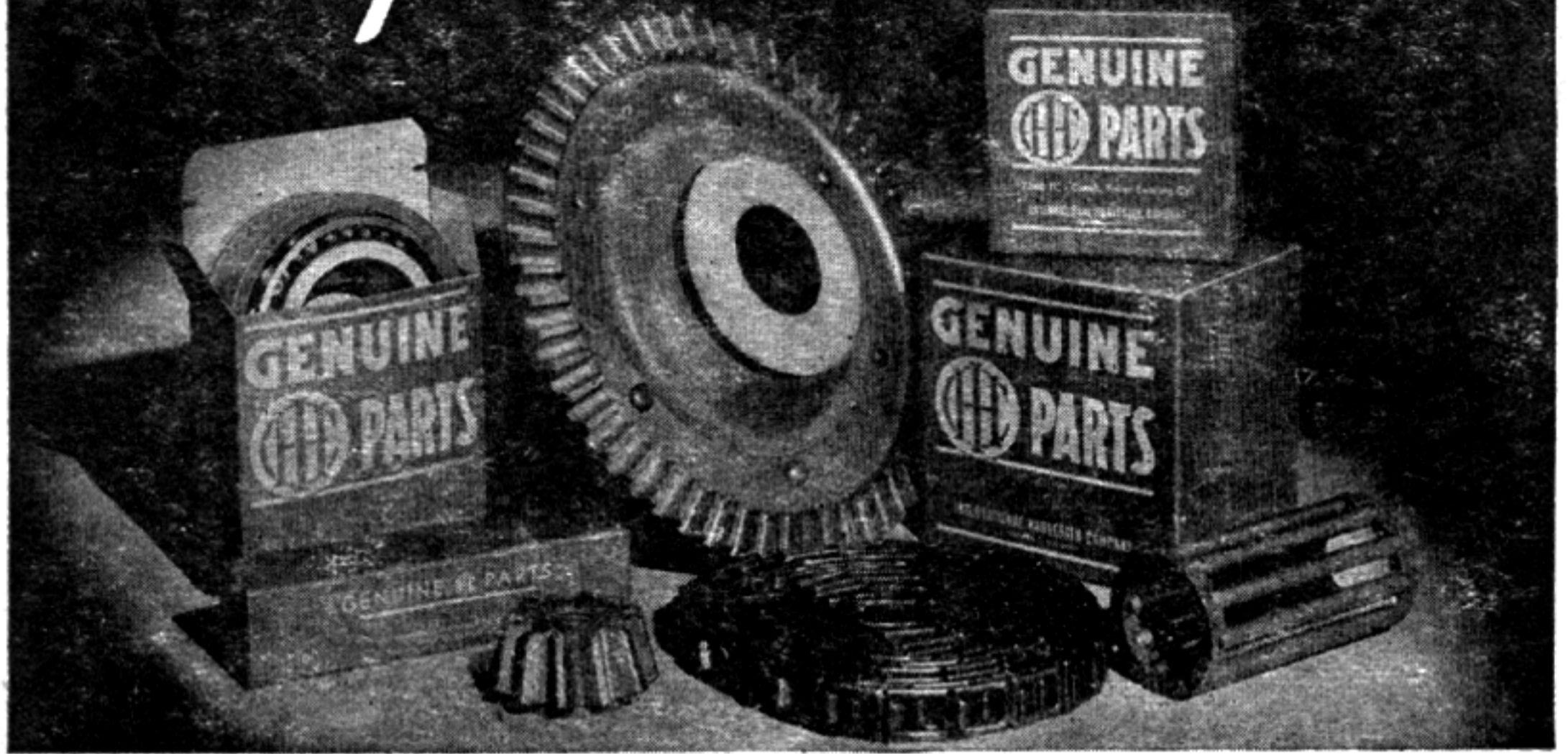

## Always Use Genuine Parts

The finest engineering skill and the most advanced manufacturing methods go into International Harvester products. Each part is built to our own high manufacturing standards. These are important things to remember when wear and tear make new parts necessary.

Genuine IHC parts retain and continue the original performance you get when you choose International Harvester quality products. When replacing parts, don't handicap your equipment. For

your protection be sure to use GENUINE IHC SERVICE PARTS.

International Harvester dealers' bins are well stocked with genuine IHC parts. Additional stocks are available at a nearby Company-owned branch. And back of these parts departments are well-equipped service stations staffed by factory-trained servicemen.

When selecting new farm operating equipment, keep in mind the protective service rendered by the International Harvester dealer in your community.



**INTERNATIONAL HARVESTER COMPANY**  
180 NORTH MICHIGAN AVE. CHICAGO 1, ILLINOIS, U.S.A.

*A Complete List of Parts for this tractor will be supplied on request.*