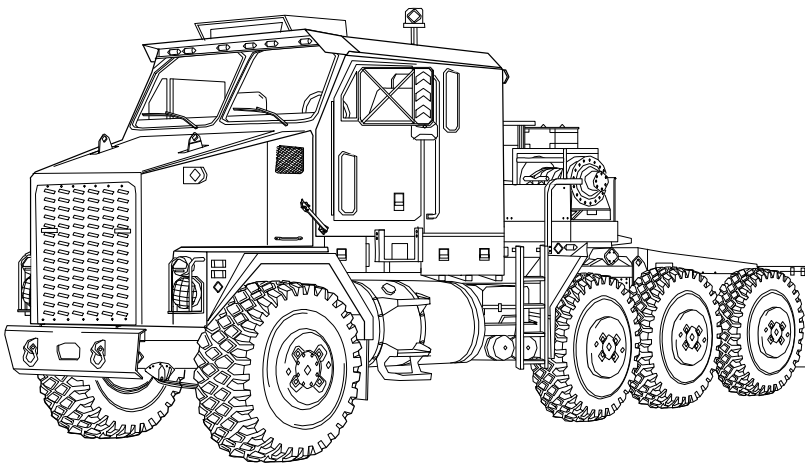


VOLUME NO. 1

**TECHNICAL MANUAL
UNIT MAINTENANCE**



**TRUCK, TRACTOR, M1070, 8 X 8,
HEAVY EQUIPMENT TRANSPORTER (HET)**

NSN 2320-01-318-9902

EIC: B5C

DISTRIBUTION STATEMENT A: Approved for public release; distribution is unlimited.

* Supersedes TM 9-2320-360-20-1 dated 31 March 1994.

HOW TO USE THIS MANUAL	IV
GENERAL INFORMATION	1-1
EQUIPMENT DESCRIPTION AND DATA	1-3
PRINCIPLES OF OPERATION	1-4
SERVICE UPON RECEIPT	2-2
PREVENTIVE MAINTENANCE CHECKS AND SERVICES	2-5
TROUBLESHOOTING	2-63
MAINTENANCE PROCEDURES	2-984
PREPARATION FOR STORAGE OR SHIPMENT	2-989
SUBJECT INDEX	INDEX-1

HEADQUARTERS, DEPARTMENT OF THE ARMY

MAY 2007

WARNING**CARBON MONOXIDE (EXHAUST GAS) CAN KILL YOU**

Carbon monoxide is a colorless, odorless, DEADLY POISONOUS gas and when breathed deprives body of oxygen and causes SUFFOCATION. Breathing air with carbon monoxide produces symptoms of headache, dizziness, loss of muscular control, a sleepy feeling, and coma. Permanent BRAIN DAMAGE or DEATH may result from severe exposure.

The following precautions MUST be followed to ensure personnel are safe whenever personnel heater or main or auxiliary engine is operated for any purpose.

- DO NOT operate personnel heater or engine of vehicle in enclosed area without adequate ventilation.
- DO NOT idle engine for long periods without ventilator blower operation. If tactical situation permits, open hatches.
- DO NOT drive any vehicle with inspection plates, cover plates, or engine compartment doors removed unless necessary for maintenance purposes.
- NEVER sleep in a vehicle when the heater is operating or the engine is idling.
- BE ALERT at all times during vehicle operation for exhaust odors or exposure symptoms. If either are present, IMMEDIATELY EVACUATE AND VENTILATE the area. Affected personnel treatment shall be: expose to fresh air; keep warm; DO NOT PERMIT PHYSICAL EXERCISE; if necessary, give artificial respiration as described in FM 4-25.11 and get medical attention.
- BE AWARE; neither the gas particulate filter unit nor field mask for nuclear, biological, and chemical protection will protect you from carbon monoxide poisoning.

THE BEST DEFENSE AGAINST CARBON MONOXIDE POISONING IS GOOD VENTILATION.

WARNING

Personnel hearing can be PERMANENTLY DAMAGED if exposed to constant high noise levels of 85 dB (A) or greater. Wear approved hearing protection devices when working in high noise level areas. Personnel exposed to high noise levels shall participate in a hearing conservation program in accordance with DA PAM 40-501. Hearing loss occurs gradually but becomes permanent over time.

WARNING

Wear eye protection and use care when replacing snap rings and retaining rings. Snap/retaining rings are under spring tension and can act as projectiles when released and may cause severe eye injury.

WARNING

Fuel and oil are slippery and can cause falls. To avoid injury, wipe up spilled fuel or oil with rags.

WARNING

- Adhesive -sealants and sealing compounds can burn easily, can give off harmful vapors, and are harmful to skin and clothing. To avoid injury or death, keep away from open fire and use in well-ventilated area. If sealing compound gets on skin or clothing, wash immediately with soap and water.
- Adhesive causes immediate bonding on contact with eyes, skin, or clothing and also gives off harmful vapors. Wear protective goggles and use in well-ventilated area. If adhesive gets in eyes, try to keep eyes open; flush eyes with water for 15 minutes and get immediate medical attention.
- On direct contact, uncured silicone sealant irritates eyes. In case of contact, flush eyes with water and seek medical attention. In case of skin contact, wipe off and flush with water.

WARNING

SOLVENT CLEANING COMPOUND (DRY CLEANING SOLVENT)

Solvent cleaning compound MIL-PRF-680 Type II and III may be irritating to the eyes and skin. Use protective gloves and goggles. Use in well-ventilated areas. Use respirator as needed. Accidental ingestion can cause irritation of digestive tract and respiratory tract, may cause lung and central nervous system damage. Can be fatal if swallowed. Inhalation of high/massive concentrations can cause coma or be fatal. First aid for ingestion: do not induce vomiting. Seek immediate medical attention. First aid for skin contact: remove contaminated clothing. Wash skin thoroughly with soap and water. If symptoms persist, seek medical attention. First aid for eye contact: flush with water for 15 minutes or until irritation subsides. If symptoms persist, seek medical attention. First aid for inhalation: move to fresh air. If not breathing, provide artificial respiration. If symptoms persist, seek medical attention. Keep away from open flames and other sources of ignition. Failure to follow this warning may result in injury or death to personnel.

- The flashpoint for type II solvent cleaning compound is 141-198°F (61-92C) and type III is 200-241°F (93-116C).
- Improper cleaning methods and use of unauthorized cleaning solvents may injure personnel and damage equipment.
- Fire extinguishers should be placed nearby when using solvent cleaning compound. Failure to follow this warning may result in injury or death.
- Cloths or rags saturated with solvent cleaning compound must be disposed of IAW authorized facilities' procedures. Failure to follow this warning may result in injury.
- Eye shields must be worn when cleaning with a wire brush. Flying rust and metal particles may cause injury.

WARNING

When servicing this vehicle, performing maintenance, or disposing of materials such as engine coolant, transmission fluid, lubricants, batteries, battery acid or CARC paint, consult your Unit/local hazardous waste disposal center or safety office for local regulatory guidance. If further information is needed, please contact the Army environmental hotline at 1-800-872-3845. Improper disposal of this material may result in damage to environment or injury to personnel.

WARNING

Observe the following precautions when working on or around engine/transmission components.

- Ensure engine is cool before performing maintenance. Failure to comply may result in severe burns.
- Use caution when draining hot oil. Oil may burn exposed skin and cause injury to personnel. If injured, seek medical attention immediately.
- Never use magnetic plug in center of engine oil pan to drain oil. Failure to comply may result in injury to personnel and could cause oil to drain on vehicle components.
- When working on a running engine, use caution around rotating parts. Tools, clothing, and hands may get caught causing serious injury or death to personnel.
- Use caution when working near hood mounting bracket that extends beyond firewall. Failure to comply may result in injury to personnel.
- Parking brake must be applied, with transmission range selector and transfer case in neutral before starting DDR cylinder cutout test. Failure to comply may result in vehicle moving unexpectedly and injury to personnel.

WARNING

Observe the following precautions when working around fuel.

- Fuel is very flammable and can explode easily. To avoid serious injury or death, keep fuel away from open fire and keep fire extinguisher within easy reach when working with fuel. Do not work on fuel system when engine is hot. Fuel can be ignited by hot engine. When working with fuel, post signs that read NO SMOKING WITHIN 50 FEET OF VEHICLE.
- Never use fuel to clean parts. Fuel is highly flammable. Serious personnel injury could result if fuel ignites during cleaning.
- Starting fluid is toxic and highly flammable. Container is pressurized. Never heat container or discharge starting fluid in confined areas or near open flame. Failure to comply may result in injury to personnel. If injured, seek immediate medical attention.
- Ether is very flammable and could explode causing serious injury or death. Keep ether cylinders away from heat and open flame.

WARNING

Observe the following precautions when working on or around exhaust system components.

- Ensure exhaust pipe, tube, and muffler are cool before performing maintenance. Failure to comply may result in serious personal injury.
- Do not operate HET Tractor with muffler removed. Toxic exhaust fumes may enter cab, resulting in injury or death to personnel.
- Muffler weighs 91 lb (41 kg). Assistant is required when replacing muffler. Failure to comply may result in injury to personnel.
- Support tail pipe guards when replacing mounting hardware to prevent from falling, possibly causing injury to personnel.

WARNING

Observe the following precautions when working on or around cooling system components.

- Coolant and radiator may be very hot and under pressure from engine operation. Ensure engine and radiator are cool before performing maintenance. Failure to comply may cause serious injury.
- Keep out from under radiator while supported by lifting device to prevent serious injury.
- Keep out from under fan while removing it to prevent serious injury.

WARNING

Observe the following precautions when working on or around electrical system components.

- Remove rings, bracelets, watches, necklaces, and any other jewelry before working around HET Tractor. Jewelry can catch on equipment and cause injury or short across electrical circuit and cause severe burns or electrical shock. Batteries can explode from a spark. Battery acid is harmful to skin and eyes. Always wear eye protection when working with batteries.
- Batteries must be disconnected before checking cables and wires on starter or tightening any connections. Failure to comply may result in injury to personnel.
- Battery acid (electrolyte) is extremely harmful. Always wear safety goggles and rubber gloves and do not smoke when performing maintenance on batteries. Injury will result if acid contacts skin or eyes. Wear rubber apron to prevent clothing being damaged.
- Never use open flame to apply heat to heatshrink tubing. Failure to comply may result in injury to personnel.
- Allow solder to cool before handling. Failure to comply may result in injury to personnel.
- Allow heatshrink tubing to cool before handling. Failure to comply may result in injury to personnel.
- Starter weighs 72 lb (33 kg) and is difficult to handle. To prevent injury, use caution when removing.

WARNING

Support propeller shaft while performing maintenance. Personnel may be injured if propeller shaft falls.

WARNING

Observe the following precautions when working on or around brake system components.

- Brake shoes may be coated with dust. Breathing dust may be harmful to personnel. Wear filter mask approved for use against brake dust.
- Do not allow grease or oil to contact brake linings. Linings can absorb grease and oil, causing early glazing and very poor brake action. Failure to comply may result in serious injury or death to personnel.

WARNING

Observe the following precautions when working on or around brake system components (cont)

- All brakes must be adjusted when performing brake adjustment procedure. Failure to comply may cause improper braking and result in injury to personnel .
- Brake shoes are installed with strong spring tension. Keep hands clear when installing parts to prevent serious injury.
- Brake drum weighs 135 lb (61 kg). Assistance is required when replacing brake drum. Failure to comply may result in injury to personnel.
- When replacing brake shoes, all four shoes on an axle must be replaced at the same time. Failure to comply may result in improper brake operation and injury to personnel.
- Never attempt to remove upper spring brake clamp ring. Failure to comply will result in personnel injury or death.
- Never try to repair rear brake chamber. High spring tension makes repair dangerous. Severe injury or death may result.
- When working on parking brake control system vehicle may roll. Vehicle must be parked on level ground. Wheel chocks must be positioned in front of and behind one of the rear wheels to keep it from rolling. Failure to comply may result in injury or death to personnel.

WARNING

Observe the following precautions when working on or around wheels and tires.

- Hydraulic jack and jackstands must be positioned on flat surface. Placing jack or jackstands on unlevel or soft surface may result in truck falling and cause injury or death to personnel.
- If any loose or broken bolts are found after removing the wheel cover, deflate the tire completely before attempting to loosen lug nuts. Failure to comply may result in injury to personnel.
- Tire must be completely deflated before attempting to loosen nuts if any bolts are found loose or broken after removing wheel cover. Failure to comply may result in injury to personnel.
- High pressure air will be released from valve stem when core is removed. Stay clear of valve stem after core is removed. Failure to comply may result in personnel injury.
- Keep hands and fingers from between tire and bead lock. Failure to comply may result in injury to personnel.
- Tire may explode and cause serious injury or death. Place wheel and tire in safety cage before inflating. Stay back 10 ft (0.3 m) from cage when inflating. Minimum hose length is 10 ft (0.3 m).
- When conducting wheel runout check or wheel bearing check, HET Tractor must be on level ground and wheels must be chocked before parking brake is released. Otherwise, HET Tractor may roll and cause personnel injury.
- Wheel assembly weighs 523 lb (237 kg). Use caution when handling wheel. Failure to comply may result in serious injury or death to personnel.

WARNING

Observe the following precautions when working on or around steering components.

- Steering reservoir is heavy. Support steering reservoir while performing maintenance. Steering reservoir could fall resulting in injury to personnel.
- Support tee gear box before removing mounting screws to prevent injury.
- Tie rod end must be threaded into tie rod so that threads are beyond slot under clamp. Failure to comply may result in tie rod end separating from tie rod resulting in injury to personnel and loss of vehicle control.

WARNING

Observe the following precautions when working on or around cab and frame components.

- Hood springs may be under tension. Use care when replacing springs to prevent injury.
- Do not use hood as a work platform. Using hood as a work platform may result in injury to personnel and/or equipment damage.
- Hood weighs 235 lb (107 kg). Keep out from under hood. Hood could fall causing serious injury.
- Door is very heavy. If dropped, door may cause serious injury.
- Keep out from under spare wheel/tire carrier while supported by lifting device to prevent injury.

WARNING

Observe the following precautions when working on or around fifth wheel.

- Improper adjustment of fifth wheel may cause trailer to become uncoupled during operation. Serious injury or death may result.
- Fifth wheel plate must be secure before performing maintenance. Failure to do so may result in injury to personnel.
- Fifth wheel weighs 925 lb (420 kg). Use suitable lifting device to prevent injury to personnel.
- Ramp weighs 237 lb (108 kg). Keep out from under heavy parts. Falling parts may cause serious injury or death.

WARNING

Observe the following precautions when working on or around suspension system components.

- Air suspension will lower when air line/hoses are removed. To avoid injury, stay clear of HET Tractor frame until air suspension is completely lowered.
- Do not attempt to inflate air spring when it is removed from vehicle. Failure to comply may result in serious injury to personnel.
- Air suspension system may still be pressurized even though air pressure gage reads 0 psi. Remove air line slowly to allow air to escape. Failure to comply may result in air line blowing off causing serious injury to personnel.

WARNING

Observe the following precautions when working on or around winch system components.

- Always wear heavy duty gloves when handling winch cable. Never let cable run through hands. Frayed cable can cut hands severely.
- Use care when removing winch cable from drum. End of cable can spring up causing injury to personnel.
- Do not operate winch without guard in place.
- Do not place hands or feet near winch during operation.
- Auxiliary winch weighs approximately 130 lb (59 kg). Use lifting device to replace auxiliary winch. Failure to comply may result in injury to personnel.
- Control console panels are heavy. Use care when removing screws to avoid injury to personnel.

WARNING

Polyurethane Coating (CARC)

Eye and hearing protection must be worn at all times when using power tools for grinding, cutting, sawing and drilling. Failure to do so may result in injury to personnel. Chemical Agent Resistant Coating (CARC) paint contains isocyanate which is highly irritating to skin and respiratory system. High concentrations of isocyanate can produce symptoms of itching and reddening of skin, a burning sensation in the throat and nose, and watering of the eyes. In extreme concentrations, isocyanate can cause cough, shortness of breath, pain during respiration, increased sputum production, and chest tightness. First aid for ingestion: do not induce vomiting. Seek immediate medical attention. First aid for skin contact: remove contaminated clothing. Wash skin thoroughly with soap and water. If symptoms persist, seek medical attention. First aid for eye contact: flush with water for 15 minutes or until irritation subsides. If symptoms persist, seek medical attention. First aid for inhalation: move to fresh air. If not breathing, provide artificial respiration. If symptoms persist, seek medical attention.

The following precautions must be taken whenever using CARC paint:

- Protective equipment (gloves, goggles, ventilation mask) must be worn when using CARC paint.
- NEVER cut CARC-coated materials without high-efficiency, air-purifying respirators in use.
- DO NOT grind or sand painted equipment without high-efficiency, air-purifying respirators in use.
- BE AWARE of CARC paint exposure symptoms; symptoms can occur a few days after initial exposure. Seek medical help immediately if symptoms are detected.
- Use only in well-ventilated areas. Check with local environmental office for methods and locations approved for painting in accordance with local and state environmental regulations.
- ALWAYS use air line respirators when using CARC paint unless air sampling shows exposure to be below standards. Use chemical cartridge respirator if air sampling is below standards.

WARNING

After Nuclear, Biological, or Chemical (NBC) exposure of vehicle, all air filters shall be handled with extreme caution. Unprotected personnel may experience injury or death if residual toxic agents or radioactive material are present. If vehicle is exposed to chemical or biological agents, servicing personnel shall wear protective mask, hood, protective overgarments, and chemical protective gloves and boots in accordance with FM 3-11.4 All contaminated air filters shall be placed in double-lined plastic bags and moved swiftly to a segregation area away from the worksite. The same procedure applies for radioactive dust contamination. The Company NBC team should measure radiation prior to filter removal to determine extent of safety procedures required per the NBC Annex to the unit Standard Operating Procedures (SOP). The segregation area in which the contaminated air filters are temporarily stored shall be marked with appropriate NBC placards. Final disposal of contaminated air filters shall be in accordance with local SOP. Decontamination operation shall be in accordance with FM 3-11.5 and local SOP.

See FM 4-25.1 for additional first aid data.

LIST OF EFFECTIVE PAGES

Dates of issue for original pages are:

Original..... 31 May 2007

TOTAL NUMBER OF PAGES IN THIS PUBLICATION IS 1133 CONSISTING OF THE FOLLOWING:

Page No.	* Change No.
Cover	0
blank.....	0
a thru f.....	0
A/ (B blank).....	0
i thru vii/ (viii blank).....	0
Pages 1-0 thru 1-11/(1-12 blank)	0
Pages 2-1 thru 2-993 (2-994 blank)	0
INDEX-1 thru INDEX-3 (INDEX-4 blank)	0

* Zero In This Column Indicates An Original Page.

A/ (B blank)

Technical Manual
TM 9-2320-360-20-1

HEADQUARTERS
DEPARTMENT OF THE ARMY
WASHINGTON, D.C., 31 MAY 2007

UNIT MAINTENANCE

TRUCK, TRACTOR, M1070, 8 X 8, HEAVY EQUIPMENT TRANSPORTER (HET) (NSN 2320-01-318-9902) EIC:B5C

Reporting Errors and Recommending Improvements

You can help improve this publication. If you find any mistakes or if you know of a way to improve the procedures, please let us know. Submit your DA Form 2028 (Recommended Changes to Equipment Technical Publications) through the Internet on the Army Electronic Product Support (AEPS) Web site. The Internet address is <https://aeeps.ria.army.mil>. The DA Form 2028 is located under the Public Applications section on the AEPS public home page. Fill out the form and click on SUBMIT. Using this form on the AEPS site will enable us to respond quicker to your comments and to better manage the DA Form 2028 program. You may also mail, fax, or e-mail your letter or DA Form 2028 directly to: U.S. Army, TACOM Life Cycle Management Command, ATTN: AMSTA-LC-LPIT/TECH PUBS, 1 Rock Island Arsenal, Rock Island, IL 61299-7630. The email address is ROCK-TACOM-TECH-PUBS@conus.army.mil. The fax number is DSN 793-0726 or Commercial (309) 782-0726.

DISTRIBUTION STATEMENT A: Approved for public release; distribution is unlimited.

TABLE OF CONTENTS		Page
	HOW TO USE THIS MANUAL	iv
CHAPTER 1	INTRODUCTION	
Section I	General Information	1-1
Section II	Equipment Description and Data	1-3
Section III	Principles of Operation	1-4
CHAPTER 2	VEHICLE MAINTENANCE	
Section I	Repair Parts; Special Tools; Test, Measurement, and Diagnostic Equipment (TMDE); and Support Equipment	2-1
Section II	Service Upon Receipt	2-2
Section III	Preventive Maintenance Checks and Services (PMCS)	2-5
Section IV	Troubleshooting	2-63
Section V	Maintenance Procedures	2-984
Section VI	Preparation for Storage or Shipment	2-989
	SUBJECT INDEX	Index-1

* Supersedes TM 9-2320-360-20-1 dated 31 March 1994

TABLE OF CONTENTS (CONT)

		Page
CHAPTER 3	ENGINE MAINTENANCE	
Section I	Introduction	3-1
Section II	Maintenance Procedures	3-1
CHAPTER 4	FUEL SYSTEM MAINTENANCE	
Section I	Introduction	4-1
Section II	Maintenance Procedures	4-1
CHAPTER 5	EXHAUST SYSTEM MAINTENANCE	
Section I	Introduction	5-1
Section II	Maintenance Procedures	5-1
CHAPTER 6	COOLING SYSTEM MAINTENANCE	
Section I	Introduction	6-1
Section II	Maintenance Procedures	6-1
CHAPTER 7	ELECTRICAL SYSTEM MAINTENANCE	
Section I	Introduction	7-2
Section II	Maintenance Procedures	7-3
CHAPTER 8	TRANSMISSION MAINTENANCE	
Section I	Introduction	8-1
Section II	Maintenance Procedures	8-1
CHAPTER 9	TRANSFER CASE MAINTENANCE	
Section I	Introduction	9-1
Section II	Maintenance Procedures	9-1
CHAPTER 10	PROPELLER SHAFTS MAINTENANCE	
Section I	Introduction	10-1
Section II	Maintenance Procedures	10-1
CHAPTER 11	BRAKE SYSTEM MAINTENANCE	
Section I	Introduction	11-1
Section II	Maintenance Procedures	11-2
CHAPTER 12	WHEEL AND TIRE MAINTENANCE	
Section I	Introduction	12-1
Section II	Maintenance Procedures	12-1

TABLE OF CONTENTS (CONT)

		Page
CHAPTER 13	STEERING SYSTEM MAINTENANCE	
Section I	Introduction	13-1
Section II	Maintenance Procedures	13-1
CHAPTER 14	FRAME MAINTENANCE	
Section I	Introduction	14-1
Section II	Maintenance Procedures	14-1
CHAPTER 15	SUSPENSION SYSTEM MAINTENANCE	
Section I	Introduction	15-1
Section II	Maintenance Procedures	15-1
CHAPTER 16	CAB AND BODY MAINTENANCE	
Section I	Introduction	16-1
Section II	Maintenance Procedures	16-1
CHAPTER 17	WINCHES MAINTENANCE	
Section I	Introduction	17-1
Section II	Maintenance Procedures	17-1
CHAPTER 18	BODY ACCESSORY ITEMS MAINTENANCE	
Section I	Introduction	18-1
Section II	Maintenance Procedures	18-1
CHAPTER 19	SPECIAL PURPOSE KITS MAINTENANCE	
Section I	Introduction	19-1
Section II	Maintenance Procedures	19-1
CHAPTER 20	NON-ELECTRIC GAGES MAINTENANCE	
Section I	Introduction	20-1
Section II	Maintenance Procedures	20-1
CHAPTER 21	CHEMICAL, BIOLOGICAL, AND RADIOLOGICAL (CBR) EQUIPMENT MAINTENANCE	
Section I	Introduction	21-1
Section II	Maintenance Procedures	21-1
APPENDIX A	REFERENCES	A-1

TABLE OF CONTENTS (CONT)

Page

APPENDIX B	MAINTENANCE ALLOCATION CHART	
Section I	Introduction	B-1
Section II	Maintenance Allocation Chart for the HET Tractor	B-4
Section III	Tool and Test Equipment Requirements for the HET Tractor	B-20
Section IV	Remarks	B-24
APPENDIX C	EXPENDABLE/DURABLE SUPPLIES AND MATERIALS LIST	
Section I	Introduction	C-1
Section II	Expendable/Durable Supplies and Materials List	C-1
APPENDIX D	ILLUSTRATED LIST OF MANUFACTURED ITEMS	
Section I	Introduction	D-1
Section II	Manufactured Items Part Number Index	D-1
Section III	Illustrated List of Manufactured Items	D-8
APPENDIX E	TORQUE VALUES	E-1
APPENDIX F	COMMON TOOLS, SUPPLEMENTS, AND SPECIAL TOOLS/FIXTURES LIST	
Section I	Introduction	F-1
Section II	Common Tools, Supplements, and Special Tools/Fixtures List	F-2
APPENDIX G	MANDATORY REPLACEMENT PARTS LIST	
Section I	Introduction	G-1
Section II	Mandatory Replacement Parts List	G-1
APPENDIX H	DDEC III/IV DIAGNOSTIC TROUBLESHOOTING GUIDE	H-1
SUBJECT INDEX	Index-1

HOW TO USE THIS MANUAL

OVERVIEW

This technical manual (TM) is provided to help you maintain the HET Tractor at the unit maintenance level. Because of its size, it is divided into two volumes. Volume 1 contains the following major sections in order of appearance:

- **WARNING SUMMARY.** Provides a summary of the most important warnings that apply throughout the manual.
- **TABLE OF CONTENTS.** Lists, for both volumes, the chapters, sections, appendixes, and indexes with page numbers in order of appearance.
- **CHAPTER 1, INTRODUCTION.** Describes the HET Tractor and provides equipment data.

- **CHAPTER 2, VEHICLE MAINTENANCE.** This chapter contains information for finding tools; special tools; test, measurement, and diagnostic equipment (TMDE); and repair parts. It also contains the preventive maintenance checks and services (PMCS) and troubleshooting tables.
- **SUBJECT INDEX.** Lists important subjects contained in volume 1 in alphabetical order and gives the page numbers on which they are located.

Volume 2 contains the following major sections in order of appearance:

- **WARNING SUMMARY.** Provides a summary of the most important warnings that apply throughout the manual.
- **TABLE OF CONTENTS.** Lists, for volume 2, the chapters, sections, appendixes, and index with page numbers in order of appearance.

The maintenance chapters in volume 2 each concern a specific system or group of components.

- **CHAPTER 3, ENGINE MAINTENANCE**
- **CHAPTER 4, FUEL SYSTEM MAINTENANCE**
- **CHAPTER 5, EXHAUST SYSTEM MAINTENANCE**
- **CHAPTER 6, COOLING SYSTEM MAINTENANCE**
- **CHAPTER 7, ELECTRICAL SYSTEM MAINTENANCE**
- **CHAPTER 8, TRANSMISSION MAINTENANCE**
- **CHAPTER 9, TRANSFER CASE MAINTENANCE**
- **CHAPTER 10, PROPELLER SHAFTS MAINTENANCE**
- **CHAPTER 11, BRAKE SYSTEM MAINTENANCE**
- **CHAPTER 12, WHEEL AND TIRE MAINTENANCE**
- **CHAPTER 13, STEERING SYSTEM MAINTENANCE**
- **CHAPTER 14, FRAME MAINTENANCE**
- **CHAPTER 15, SUSPENSION SYSTEM MAINTENANCE**
- **CHAPTER 16, CAB AND BODY MAINTENANCE**
- **CHAPTER 17, WINCHES MAINTENANCE**
- **CHAPTER 18, BODY ACCESSORY ITEMS MAINTENANCE**
- **CHAPTER 19, SPECIAL PURPOSE KITS MAINTENANCE**
- **CHAPTER 20, NON-ELECTRIC GAGES MAINTENANCE**
- **CHAPTER 21, CHEMICAL, BIOLOGICAL, AND RADIOLOGICAL (CBR) EQUIPMENT MAINTENANCE**

The last part of volume 2 contains information which will assist you in the performance of unit maintenance on the HET Tractor.

- **APPENDIX A, REFERENCES.** Lists publications used with the HET Tractor.
- **APPENDIX B, MAINTENANCE ALLOCATION CHART.** The maintenance allocation chart denotes the level of maintenance which performs specific maintenance tasks and the time required. It also lists tools and special tools required for each task.

OVERVIEW (CONT)

- **APPENDIX C, EXPENDABLE/DURABLE SUPPLIES AND MATERIALS LIST.** Lists expendable and durable items used in the performance of maintenance.
- **APPENDIX D, ILLUSTRATED LIST OF MANUFACTURED ITEMS.** Illustrates and describes items that must be fabricated from bulk materials for repair of the HET Tractor.
- **APPENDIX E, TORQUE VALUES.** Lists the standard torques values for specific attaching hardware.
- **APPENDIX F, COMMON TOOLS, SUPPLEMENTS, AND SPECIAL TOOLS/FIXTURES LIST.** This appendix lists equipment used in the performance of maintenance and references publications which contain information regarding the equipment.
- **APPENDIX G, MANDATORY REPLACEMENT PARTS LIST.** This appendix lists the mandatory replacement parts needed to maintain the HET Tractor.
- **APPENDIX H, DDEC III/IV DIAGNOSTIC TROUBLESHOOTING GUIDE.** This appendix contains the troubleshooting for the DDEC III/IV vehicle.
- **SUBJECT INDEX.** Lists important subjects contained in Volume 2 and 3 in alphabetical order and gives the page numbers on which they are located.

FINDING INFORMATION

There are several ways to find the information you need in this manual. They are as follows:

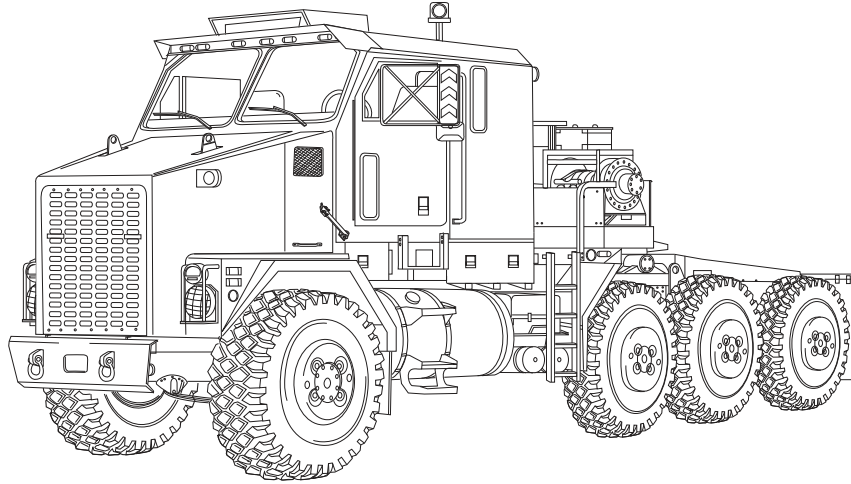
- **FRONT COVER INDEX.** The front cover index contains a list of the most important topics contained in each volume. It features a black box at the right edge of the cover which corresponds with a black box on the page containing the topic. The topics listed on the front cover are highlighted in the table of contents with a box.
- **TABLE OF CONTENTS.** Lists chapters, sections, appendixes, and indexes with page numbers in order of appearance.
- **CHAPTER INDEXES.** List paragraphs contained in the individual chapters with paragraph and page numbers in order of appearance.
- **SYMPTOM INDEX.** Lists malfunctions contained in the troubleshooting table with page numbers in order of appearance.
- **SUBJECT INDEX.** Lists all important topics with page numbers in alphabetical order.

TROUBLESHOOTING

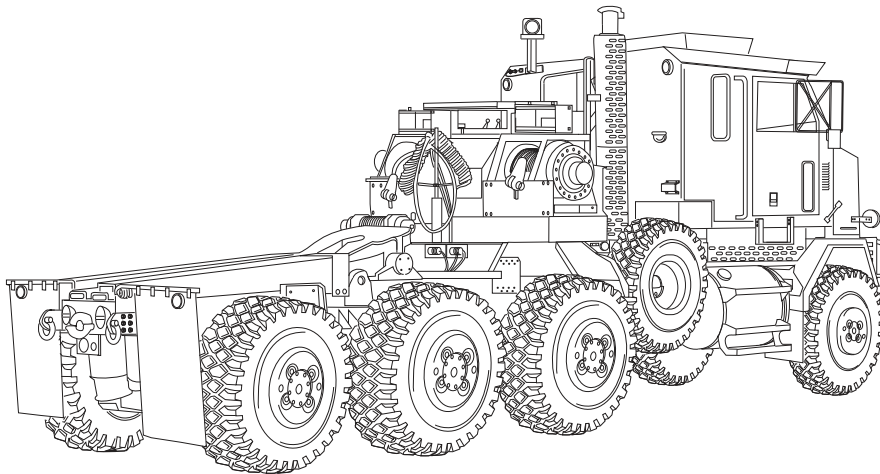
There are two types of troubleshooting tables contained in this manual, DDEC and vehicle. Always consult the vehicle troubleshooting first when an engine malfunction occurs. Refer to the DDEC troubleshooting logic table in chapter 2 to assist you in fault isolation for DDEC III/IV vehicles and to Appendix H to assist in fault isolation for DDEC III/IV vehicles. When a non-engine malfunction occurs, look at the symptom index for the vehicle troubleshooting table (also in chapter 2). Find the malfunction in the index. Turn to the page number listed for the malfunction in the troubleshooting table. Perform the steps required to correct the malfunction. If you can't find the malfunction, or the malfunction is not corrected, notify your supervisor. When troubleshooting electrical circuits refer to the electrical schematics for connectors, routing, wire numbers, etc.

MAINTENANCE

- **SCHEDULED MAINTENANCE.** Your scheduled maintenance is located in table 2-1, PMCS. These checks and services are mandatory at the intervals listed. Always follow the WARNINGS and CAUTIONS.
- **UNSCHEDULED MAINTENANCE.** Unscheduled maintenance is located in chapters 3 thru 21. The PMCS and troubleshooting tables often reference you to these procedures. When you perform maintenance, look over the entire procedure before starting. Make sure you have the necessary tools and materials at hand. Always follow the WARNINGS and CAUTIONS.



Left Front View



Right Rear View

TRUCK, TRACTOR, M1070, 8 X 8,
HEAVY EQUIPMENT TRANSPORTER (HET)

CHAPTER 1 INTRODUCTION

Contents	Para	Page
Scope	1-1	1-1
Maintenance Forms, Records, and Reports	1-2	1-1
Destruction of Army Materiel to Prevent Enemy Use	1-3	1-1
Preparation for Storage or Shipment	1-4	1-2
Nomenclature Cross-Reference	1-5	1-2
Reporting Equipment Improvement Recommendations (EIR)	1-6	1-2
Equipment Improvement Report and Maintenance Digest (EIR MD) and Equipment Improvement Report and Maintenance Summary (EIR MS)	1-7	1-2
Warranty Information	1-8	1-2
Metric System	1-9	1-3
Equipment Characteristics, Capabilities, and Features	1-10	1-3
Location and Description of Components	1-11	1-3
Equipment Data	1-12	1-3
Safety, Care, and Handling	1-13	1-3
Power Train	1-14	1-4
Electrical Systems	1-15	1-5
Steering System	1-16	1-7
Air System	1-17	1-8
Winch System	1-18	1-10
Central Tire Inflation System (CTIS)	1-19	1-11

Section I. GENERAL INFORMATION

1-1. SCOPE

- a. Type of Manual. Unit Maintenance Instructions, TM 9-2320-360-20.
- b. Model Number and Equipment Name. Truck, Tractor, M1070, 8 x 8, Heavy Equipment Transporter (HET).
- c. Purpose of Equipment. The HET Tractor and the M1000 Trailer form the Heavy Equipment Transport System (HETS). HETS will be used to load, unload, and transport the M1 Series Main Battle Tank (MBT) during administrative and tactical operations.

1-2. MAINTENANCE FORMS, RECORDS, AND REPORTS

Department of the Army forms and procedures used for equipment maintenance will be those prescribed by DA Pam 750-8, The Army Maintenance Management System (TAMMS).

1-3. DESTRUCTION OF ARMY MATERIEL TO PREVENT ENEMY USE

Command decision, according to tactical situation, will determine when the destruction of the HET Tractor will be accomplished. A destruction plan will be prepared by the using organization unless one has been prepared by a higher authority. For general destruction procedures for this equipment, refer to TM 750-244-6, Procedures for Destruction of Tank-Automotive Equipment to Prevent Enemy Use (U.S. Army Tank-Automotive Command).

1-4. PREPARATION FOR STORAGE OR SHIPMENT

Instructions for preparation for storage or shipment are provided in paragraph 2-22 of this manual.

1-5. NOMENCLATURE CROSS-REFERENCE

Table 1-1 lists the nomenclature cross-references used in this manual.

Table 1-1. Nomenclature Cross-Reference

<u>Common Name</u>	<u>Official Nomenclature</u>
DDR	CTS J1708 Application
STE/ICE-R	CTS/ICE
Cable	Wire rope
Cold Start System	Ether quick-start system
Engine Coolant	Antifreeze, ethylene glycol mixture
Gladhand	Quick-disconnect coupling
HET Tractor	Truck, Tractor, M1070, 8 x 8, Heavy Equipment Transporter (HET)
Jacobs Brake	Engine retarder

1-6. REPORTING EQUIPMENT IMPROVEMENT RECOMMENDATIONS (EIR)

If your HET Tractor needs improvement, let us know. Send us an EIR. You, the user, are the only one who can tell us what you don't like about your equipment. Let us know why you don't like the design. Put it on an SF 368 (Quality Deficiency Report). Mail it to us at: Commander, U.S. Army Tank-Automotive and Armaments Command, ATTN: AMSTA-QRT, Warren, MI 48397-5000. We'll send you a reply.

1-7. EQUIPMENT IMPROVEMENT REPORT AND MAINTENANCE DIGEST (EIR MD) AND EQUIPMENT IMPROVEMENT REPORT AND MAINTENANCE SUMMARY (EIR MS)

The quarterly EIR MD, TB 43-001-39 series, contains valuable field information on the equipment covered in this manual. It is compiled from some of the Quality Deficiency Reports that have been prepared on the vehicles covered in this manual. Many of these articles result from comments, suggestions, and improvement recommendations that were submitted to the EIR program. It also contains information on equipment improvements, minor alterations, proposed Modification Work Orders (MWOs), warranties, actions taken on some of the DA Form 2028's (Recommended Changes to Publications), and advance information on proposed changes that may affect this manual. In addition, the more maintenance significant articles (including minor alterations, field-fixes, etc.) that have a continuing need in the field are republished in the EIR MS for TACOM equipment (TM 43-1043). Refer to both of these publications periodically, especially the TB 43-001-39 series, for the most current and authoritative information on the equipment. The information will help you to do a better job and will advise of the latest changes to this manual. Also refer to DA Pam 25-30 and Appendix A, References, of this manual.

1-8. WARRANTY INFORMATION

The HET Tractor is warranted by Oshkosh Truck Corporation for 12 months; 4 months additional if placed in storage. (Refer to TB 9-2320-360-14, page 3, paragraph i for details.) Warranty starts on the date found in block 21, DD Form 250, in the logbook. Report all defects in material or workmanship to the supervisor, who will take the appropriate action. For complete information covering warranties, refer to Warranty Technical Bulletin for Truck, Tractor, M1070, 8 x 8, Heavy Equipment Transporter (HET) TB 9-2320-360-14.

1-9. METRIC SYSTEM

The equipment described herein contains metric components and requires metric common and special tools, therefore, Metric units in addition to English units will be used throughout this manual. An English-to-metric conversion table is included inside the back cover of this manual.

Section II. EQUIPMENT DESCRIPTION AND DATA

1-10. EQUIPMENT CHARACTERISTICS, CAPABILITIES, AND FEATURES

Refer to TM 9-2320-360-10, for equipment characteristics, capabilities, and features.

1-11. LOCATION AND DESCRIPTION OF COMPONENTS

Refer to TM 9-2320-360-10, for location and description of components.

1-12. EQUIPMENT DATA

Refer to TM 9-2320-360-10, for equipment data.

1-13. SAFETY, CARE, AND HANDLING

Significant Hazards and Safety Recommendations. Significant hazards and safety recommendations are listed in table 1-2.

Table 1-2. Significant Hazards and Safety Recommendations

Operating Hazard	Safety Recommendation or Precaution	Condition*
Low oil pressure/ high coolant temperature	Stop engine operation when CHECK GAUGES and CHECK ENGINE indicators are lit, engine warning alarm sounds, and gages indicate abnormal readings.	Abnormal
Low air pressure	Do not drive HET Tractor while low air pressure alarm is sounding or LOW AIR indicator is lit.	Abnormal
Electric shock	Do not wear watches, rings, or other jewelry while working on or near an electrical circuit.	Abnormal
Refueling vehicle	Fuel is very flammable and can explode easily. To avoid serious injury or death, keep fuel away from open flame and keep fire extinguisher within easy reach when working with fuel. Do not work on fuel system when engine is hot. Fuel can be ignited by hot engine. When working with fuel, post sign that says: NO SMOKING WITHIN 50 FEET OF VEHICLE.	Normal

*Category of hazards as to whether or not they may be expected under normal or abnormal operating conditions.

1-13. SAFETY, CARE, AND HANDLING (CONT)

Table 1-2. Significant Hazards and Safety Recommendations (Cont)

Operating Hazard	Safety Recommendation or Precaution	Condition*
Connecting/Disconnecting trailer.	Make sure that position of assistant is known at all times. Make sure no one is standing directly behind tractor or trailer during connection/disconnection.	Normal
Vehicle instability on a hill.	Avoid driving diagonally across a hill. HET Tractor may roll, causing equipment damage and injury or death to personnel.	Normal
Winching operations.	Do not use winches for lifting personnel. Always wear heavy gloves when handling winch cable. Never let cable run through hands. Frayed cable can cut severely. Do not operate winch without guard in place. Do not place hands or feet near winch during operation. Ensure that both DRIVER SIDE and PASSENGER SIDE WINCH KICKOUT controls are disengaged prior to paying out winch cables. Failure to disengage KICKOUT controls may result in injury to personnel.	Normal
*Category of hazards as to whether or not they may be expected under normal or abnormal operating conditions.		

Section III. PRINCIPLES OF OPERATION

1-14. POWER TRAIN

Power for the HET Tractor is generated by a two-stroke, V-type diesel engine coupled directly to an automatic transmission. The engine is rated at 500 brake horsepower.

The engine is equipped with an electronic control system that regulates fuel delivery to each injector as well as governing engine speed for power takeoff operation. Engine sensors and engine performance can be checked using a plug-in diagnostic reader.

Power from the engine drive shaft transmits torque that is multiplied for greater drive power by a torque converter when needed.

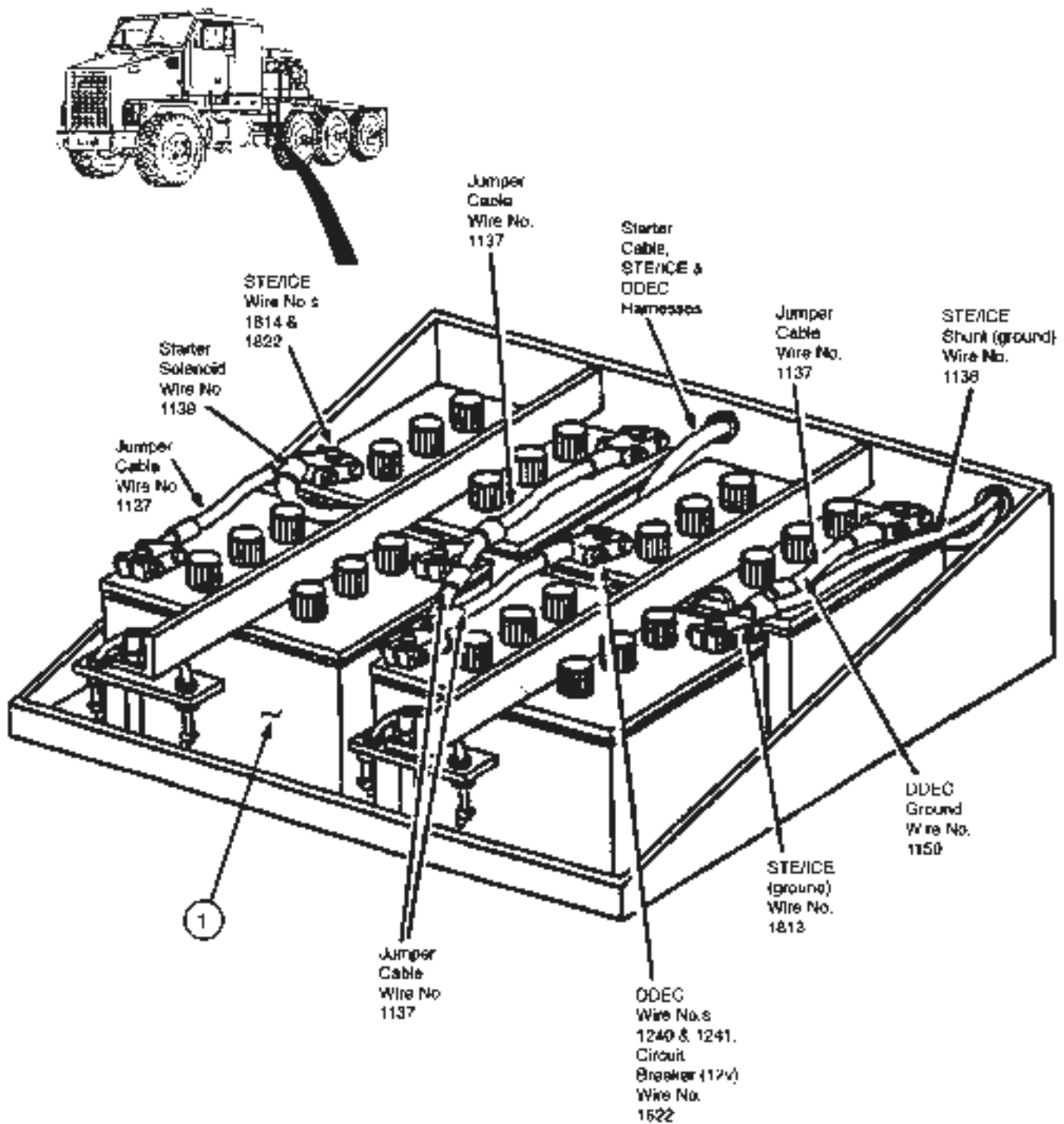
Five forward drive ranges can be manually selected, depending on the terrain and conditions. The transmission will automatically downshift as engine speed and throttle position change.

When the lockup clutch is automatically applied, power is transmitted mechanically through the lockup clutch. A direct drive is engaged from the engine to a converter turbine shaft.

Power from the transmission is directed to the transfer case and propeller shafts forward and rear. The front and rear tridem axles are each equipped with planetary wheel ends. In low range, driver-controlled lockouts in the differentials provide positive drive to all four axles.

1-15. ELECTRICAL SYSTEM

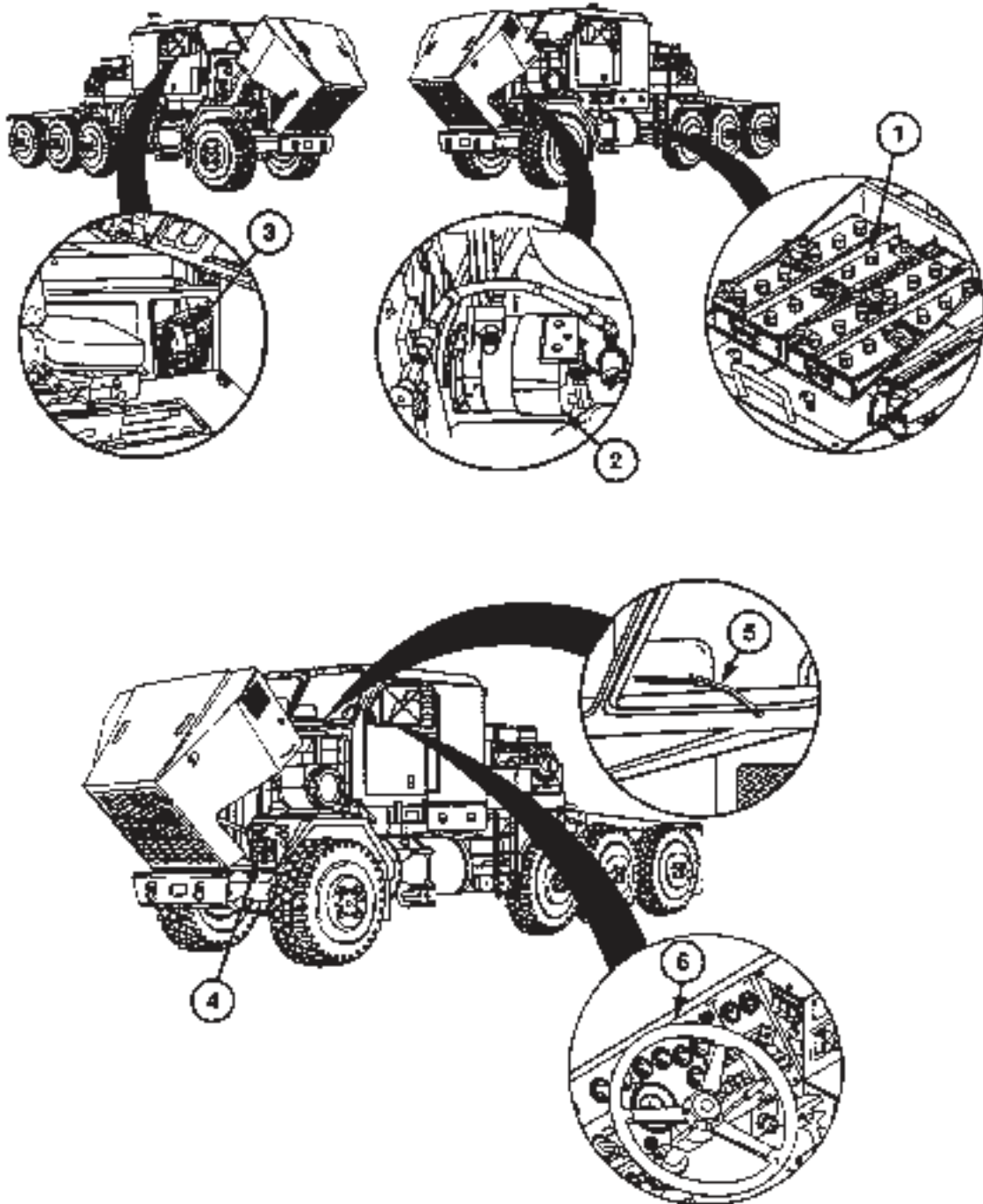
The HET Tractor electrical system consists of two different circuits, 12 Vdc and 24 Vdc. Four 12-volt storage batteries (1) connected in series parallel provide current to both circuits.



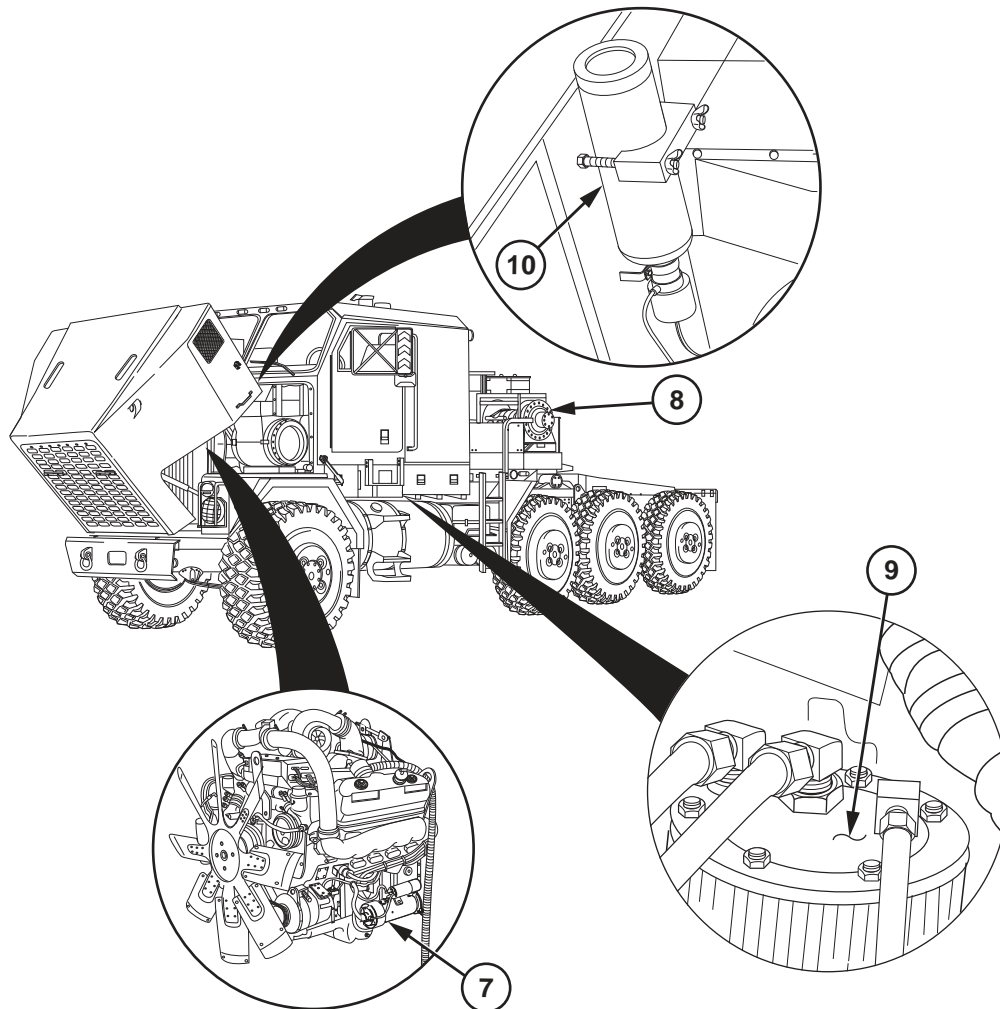
1-15. ELECTRICAL SYSTEM (CONT)

Two belt-driven alternators provide current to the electrical system during normal operation, and recharge the batteries while the engine is operating. The 24 Vdc system utilizes an alternator (2) with 130 amp capacity. The 12 Vdc system utilizes an alternator (3) with 145 amp capacity.

The headlights (4), trailer lights, windshield wipers (5) and washer motors, instrument panel/dash lighting and switches (6), and warning lights and gages inside the cab are operated with the 12 Vdc system.



The starter motor (7), winches (8), Central Tire Inflation System (CTIS), air dryers (9), trailer lights, and ether injection system (10) are operated with the 24 Vdc system.



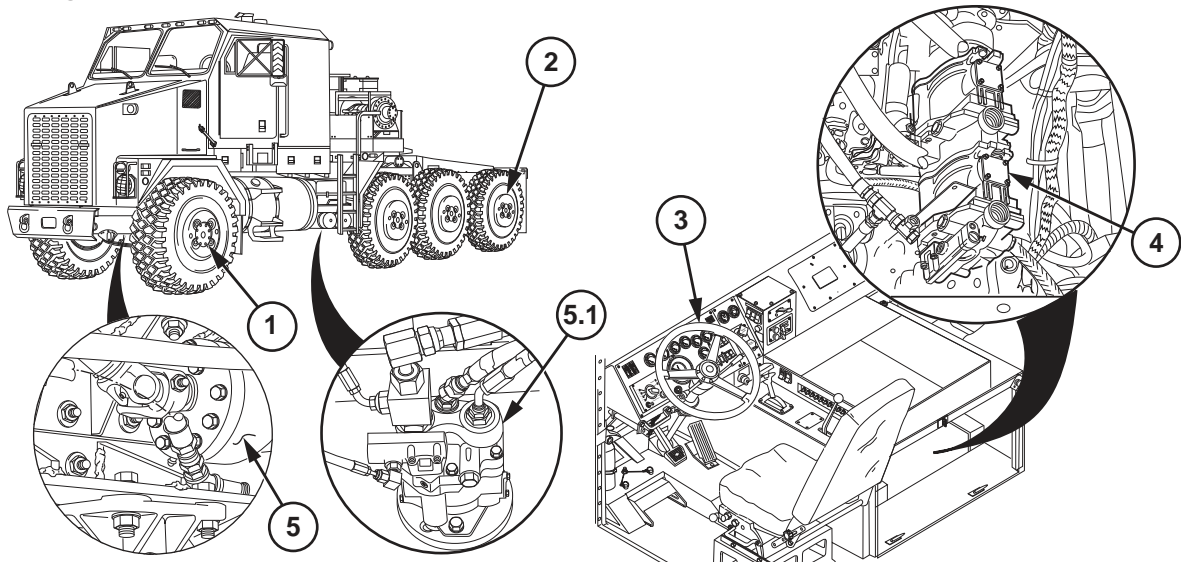
The starter motor solenoid receives 24 Vdc from the storage batteries through the engine starter magnetic switch auxiliary contacts and the neutral start relay. If the transmission range selector is not in the N (neutral) position prior to startup, the engine cannot be started.

Warning lights and gages that indicate system malfunctions include: CHECK GAUGES alarm, CHECK ENGINE indicator, and CHECK GAUGES indicator.

1-16. STEERING SYSTEM

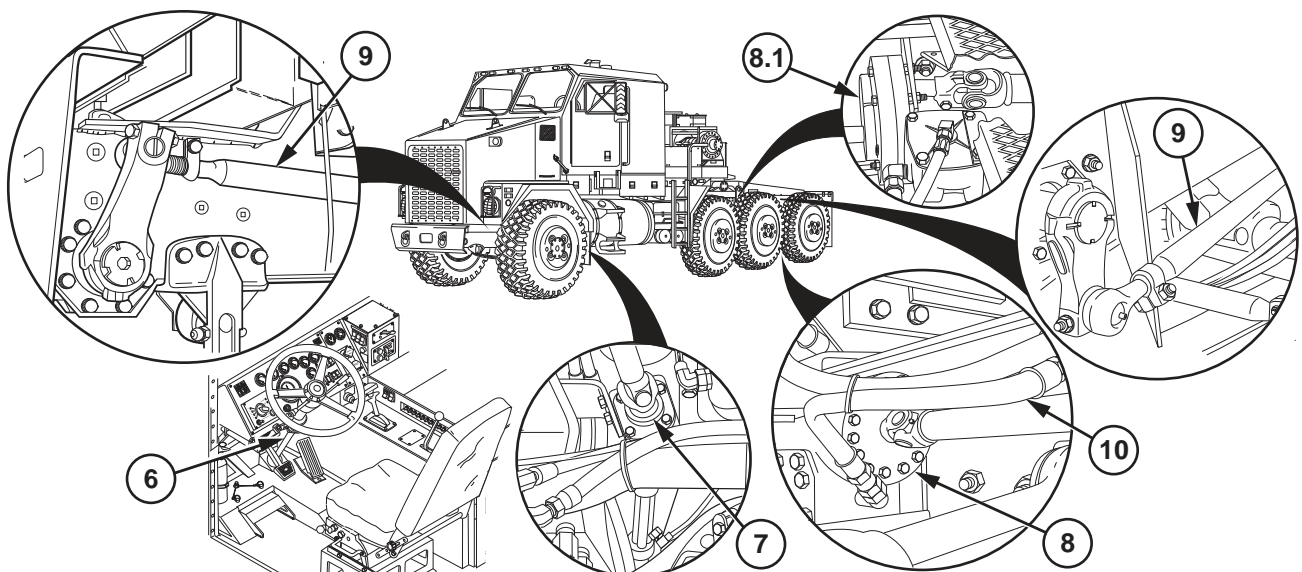
The steering system uses two steering axles, one at the front (No. 1) (1) and one at the rear (No. 4) (2). Each axle turns in response to turning the steering wheel (3) in the cab.

Steering power is generated by a steering pump (4) driven directly at the engine providing pressure to two steering gears (5), one at each steering axle. The steering pump delivers fluid to enable the operator to turn the wheels of a fully-loaded truck. An interconnected series of shaft linkages rotate with hydraulic power assist to turn the two axles. In the event of main steering system failure, an auxiliary steering pump (5.1) connected to the transfer case provides power steering.



As the steering wheel is turned, the rotational motion of the upper steering assembly shafts (6) is translated at a tee gear box (7) below the cab to both the front and rear power steering gears (8). A steering reduction gear (8.1) reduces the steering angle on axle no. 4. The steering gears multiply the rotational force to a pair of drag links (9) and four axle steering arms that apply directional motion to turn the axles.

In the event a steering line (10) to no. 4 steering axle is severed or fluid leaks from the system (Power steering is inoperable.), the truck can be steered for short distances in emergency situations.



1-17. AIR SYSTEM

The air system operates the service and parking brakes, rear suspension system, and the CTIS. The air system also enables operation of the transfer case and interaxle lockups, winch tensioners and kickouts, windshield washer, and horns.

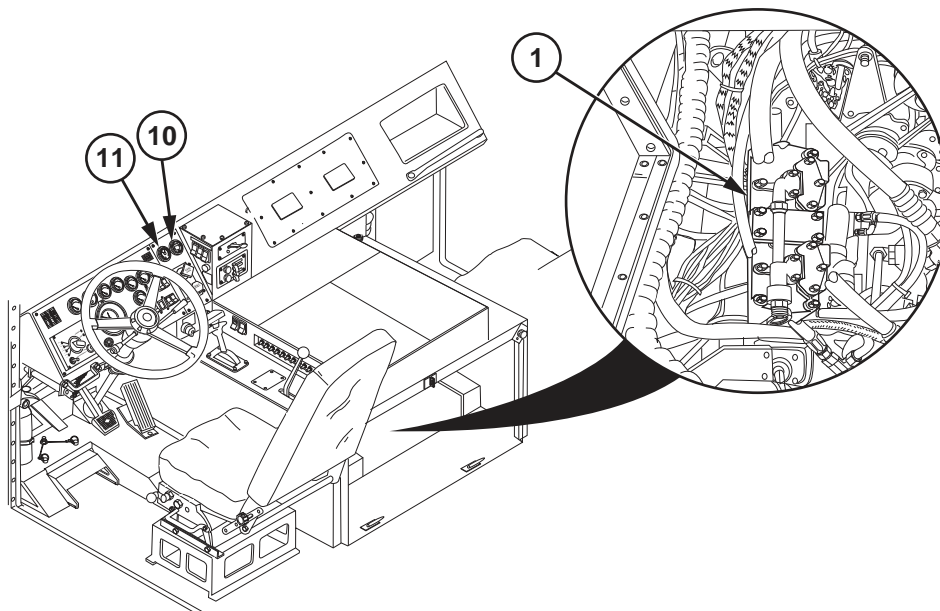
The air system on the HET Tractor consists of an engine-driven air compressor (1), a purge tank (2), and five air reservoirs (3 thru 7). Reservoir (3) supplies air to reservoirs (4 thru 7). Three reservoirs (5 thru 7) are interconnected and separated from reservoir (4) with check valves. Air from reservoir (4) is supplied to service brakes on all four axles and parking brakes on the rear tridem axles, transfer case and interaxle lockups, winch tensioners and kickouts, windshield washer, and horns. The service brakes are actuated by relay valves which are controlled by the operator pressing the brake treadle in the cab. The parking brakes are also actuated by relay valves which are controlled by hand controls. In the event of the loss of system air pressure, the spring brake valve will modulate the parking brakes so the HET Tractor can be stopped safely. Reservoirs (5 thru 7) supply air to operate the CTIS, service and parking brakes on rear tridem axles, and rear suspension system. Air is drawn from the engine air intake and routed to the air compressor (1) where it is pressurized. Air dryers (8 and 9) remove moisture from the pressurized air. Air from the dryers goes to the purge reservoir (2) and air reservoir (3).

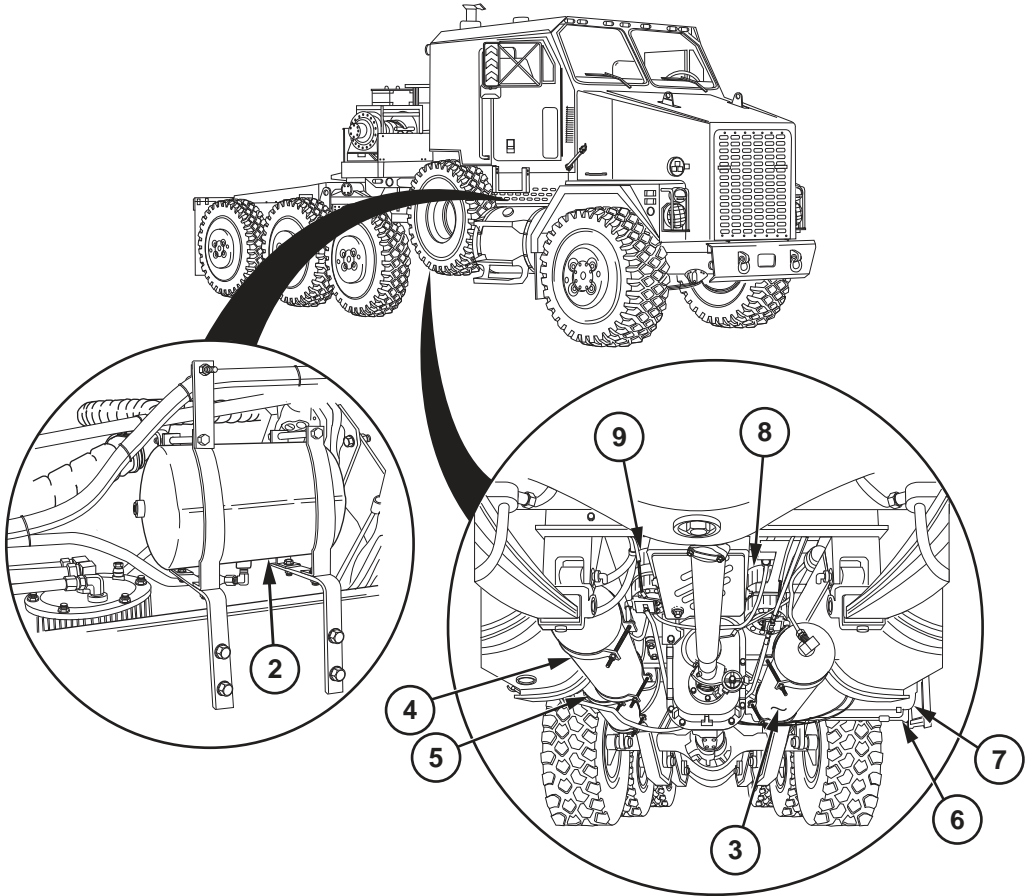
System protection elements include an air cleaner restriction indicator (10) that determines whether air flow through the air cleaner is impeded. In the cab, air pressure in reservoir (4) is indicated by the green needle on the AIR PRESSURE gage (11). The red needle on the gage (11) indicates air pressure in reservoirs (5 thru 7). If air pressure falls below 60 psi (414 kPa) in any of the reservoirs, warning alarm will sound and LOW AIR indicator will light.

The rear suspension system contains a pair of suspension air springs on each rear axle that automatically inflates or deflates according to load. Air to the air springs is regulated by a height control valve.

Purging the air in the air dryers is automatically done when 125 psi (862 kPa) system pressure is reached at the compressor. The compressor cycle is stopped and air from purge tank clears accumulated water through a valve on the bottom of the air dryer.

Air to the transfer case enables engagement of four-wheel drive in high or low gear range. An interaxle lockup pilot valve also prevents the axles from locking up in high ranges.



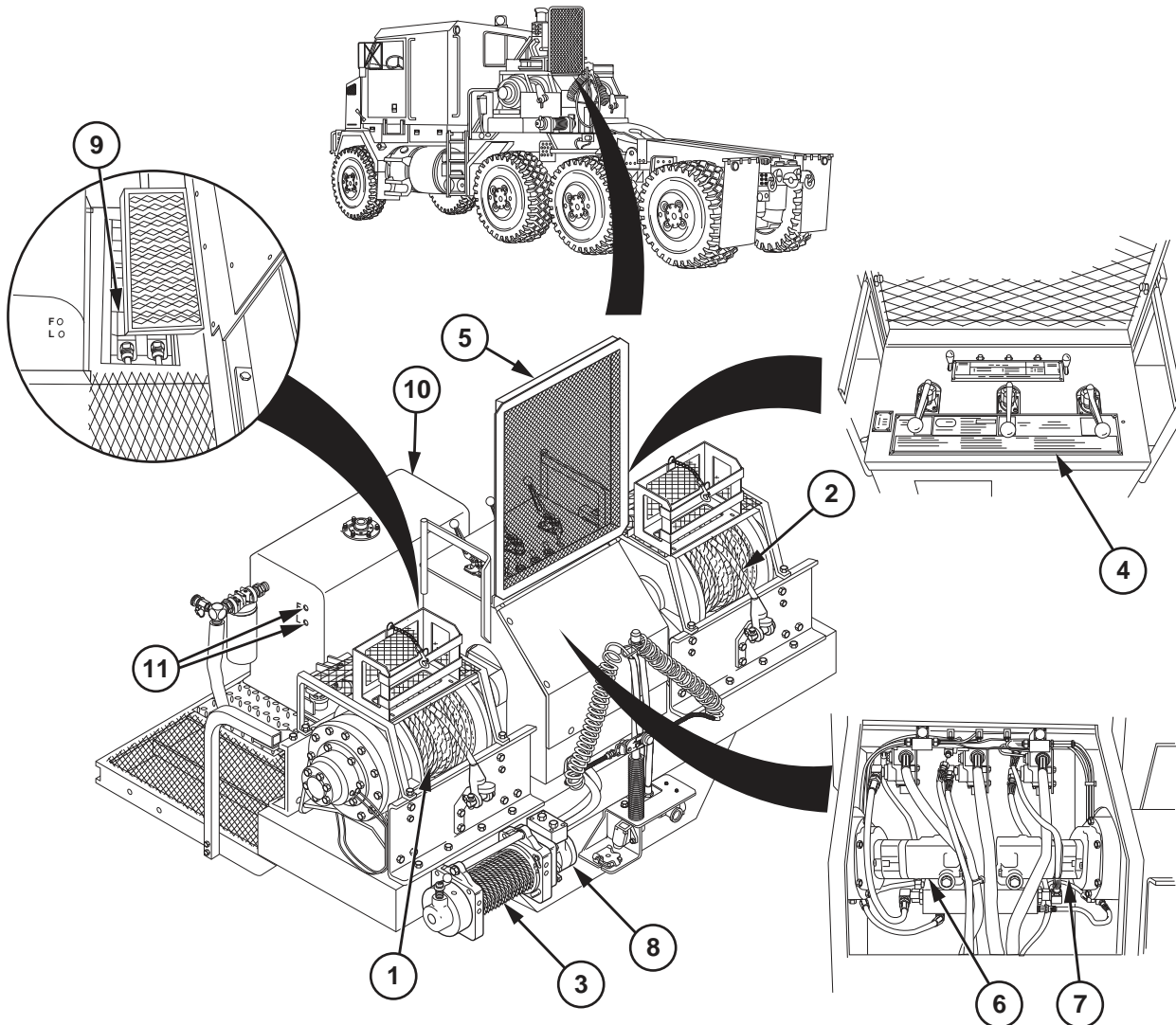


1-18. WINCH SYSTEM

The winch system operates hydraulically and consists of two main winches (1 and 2) and an auxiliary winch (3). The main winches operate independently of each other and are used to recover, load, and unload heavy tracked and wheeled vehicles. The main winches are mounted side-by-side directly to the winch platform. The auxiliary winch is used to pull the main winch cable out to the payload. The auxiliary winch is mounted to the winch platform just below the driver's side main winch.

The winches are controlled from the operator's station (4). The operator is protected by a personnel guard (5) during winch operations. The main winch controls are the winch kickout control, cable hold down lever, engine idle selector switch, engine high idle lock switch, winch speed control switch, and the winch drum control.

Each main winch incorporates a two-speed hydraulic motor (6 and 7). The hydraulic motor is used to provide power. It converts hydraulic horsepower from the pump and control circuitry to rotary mechanical horsepower for driving the gear system. A single-speed motor (8) is used by the auxiliary winch. A Power Take-Off (PTO) driven hydraulic pump (9) supplies the winch system with hydraulic oil from the reservoir (10). A two-piece driveshaft connects the transmission driven PTO to the hydraulic pump (9). A view gage (11) on the reservoir indicates the hydraulic oil level. All winches have a fail-safe brake and winch brake valve for winch load control.



1-19. CENTRAL TIRE INFLATION SYSTEM (CTIS)

The Central Tire Inflation System (CTIS) allows the HET operator to adjust the vehicle tire pressure to one of four predetermined settings. Each tire pressure setting has a vehicle speed limitation. If the average vehicle speed exceeds this limit, the CTIS will activate an overspeed light.

The CTIS consists of five major components. An electronic controller (1), mounted on the dash, contains the switches and indicator lights for system operation. The controller's Read Only Memory (ROM) contains the working instructions for the power manifold (2).

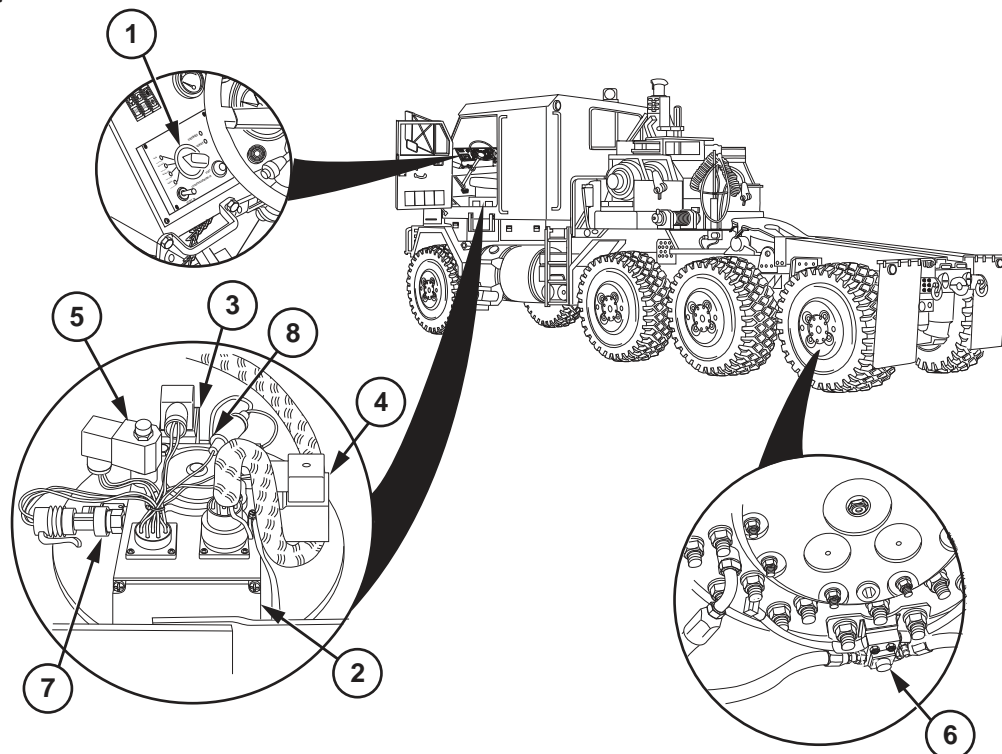
The power manifold (2), located under the driver's seat, contains an inflation valve (3) for increasing tire pressures and a deflation valve (4) to reduce tire pressures. The power manifold's quick-release valve (5) is closed during checking, inflating, and deflating modes. The quick-release valve opens at the end of a cycle to rapidly exhaust all air pressure from the CTIS, which in turn closes all wheel valves (6).

The power manifold (2) has two other components in addition to the valves. They are a pressure transducer (7) that monitors system pressure for the CTI controller and a low air pressure switch (8) used to shut the CTIS off when chassis air pressure is less than 85 psi. 110 psi is required to restart the system.

Directly under the power manifold (2) is the porting block, to which the air lines to the axles are connected. Air pressure passes through these lines and the axle assemblies to the wheel valves (6). Air pressure is present in the CTIS lines only when the system is monitoring (or adjusting) tire pressures. At all other times, the system has no air pressure.

The CTIS has an automatic routine that checks for moderate to large air leaks or air loss. During the initial start of the CTIS, the quick-release valve (5) is closed and the inflation valve (3) opens to attempt to build system pressure. If the transducer fails to sense that the system is capable of maintaining pressure, the CTIS will shut itself off and display a flashing low air light.

When the CTIS has completed a pressure adjustment cycle, the controller (1) starts an internal timer. If no changes occur during the next 15 minutes, a check cycle is automatically activated, during which tire pressures are measured and adjusted if necessary. This provides for improved tire life as hot tire pressures are adjusted and slowly leaking tires are kept inflated.



CHAPTER 2 VEHICLE MAINTENANCE

Contents	Para	Page
Common Tools and Equipment	2-1	2-1
Special Tools, TMDE, and Support Equipment	2-2	2-1
Repair Parts	2-3	2-1
Checking Unpacked Equipment	2-4	2-2
Deprocessing Unpacked Equipment	2-5	2-2
Hand Receipt Manual and Inventory of Equipment	2-6	2-2
Service Before Operation	2-7	2-2
PMCS Introduction	2-8	2-5
Explanation of Columns	2-9	2-5
General Maintenance Procedures	2-10	2-5
Fluid Leakage	2-11	2-6
PMCS Table	2-12	2-6
Introduction to Logic Tree Troubleshooting	2-13	2-63
Maintenance Introduction	2-14	2-984
General Removal Instructions	2-15	2-984
General Disassembly Instructions	2-16	2-984
General Cleaning Instructions	2-17	2-985
General Inspection Instructions	2-18	2-986
General Repair Instructions	2-19	2-987
General Assembly Instructions	2-20	2-988
General Installation Instructions	2-21	2-988
Preparation for Storage or Shipment	2-22	2-989
Storage	2-23	2-989

Section I. REPAIR PARTS AND SPECIAL TOOLS; TEST MEASUREMENT AND DIAGNOSTIC EQUIPMENT (TMDE) AND SUPPORT EQUIPMENT

2-1. COMMON TOOLS AND EQUIPMENT

For authorized common tools and equipment, refer to the Modified Table of Organization and Equipment (MTOE) applicable to your unit.

2-2. SPECIAL TOOLS, TMDE, AND SUPPORT EQUIPMENT

For a listing of special tools, TMDE, and support equipment, refer to the Maintenance Allocation Chart (MAC), Appendix B, of this manual and to the repair parts and special tools list (RPSTL), TM 9-2320-360-20P.

2-3. REPAIR PARTS

Repair parts are listed and illustrated in the Repair Parts and Special Tools List (RPSTL), TM 9-2320-360-20P, covering Unit maintenance for this equipment.

Section II. SERVICE UPON RECEIPT

2-4. CHECKING UNPACKED EQUIPMENT

- a. Inspect the equipment for damage incurred during shipment. If the equipment has been damaged, report the damage on DD Form 6, Packaging Improvement Report.
- b. Check the equipment against the packing slip to see if the shipment is complete. Report all discrepancies in accordance with the instructions of DA Pam 750-8.
- c. Check to see whether the equipment has been modified.

2-5. DEPROCESSING UNPACKED EQUIPMENT

Read "Processing and Deprocessing Record of Shipping, Storage, and Issue of Vehicles and Spare Engines," tag (DD Form 1397) and follow all precautions checked. This tag should be attached to the steering wheel, shifting lever, or ENGINE switch.

2-6. HAND RECEIPT MANUAL AND INVENTORY OF EQUIPMENT

When a new HET Tractor is received by the using organization, it is necessary to inventory the equipment. For detailed procedures, refer to Hand Receipt Manual, TM 9-2320-360-10-HR.

2-7. SERVICE BEFORE OPERATION

- a. General
 - (1) Upon receipt of new, used, or reconditioned HET Tractor, the receiving organization must see if it has been properly prepared for service and is in good condition. Inspect all assemblies, subassemblies, and accessories to ensure they are in proper working order. Secure, clean, correctly adjust, and lubricate as needed (TM 9-2320-360-10 and LO 9-2320-360-12).
 - (2) Follow general procedures for all services and inspections given in TM 9-2320-360-10.
 - (3) Refer to TM 9-2320-360-10, for HET Tractor operating instructions.
- b. Inspection and Servicing Equipment
 - (1) General Procedures

NOTE

If HET Tractor has been driven to the using organization, most of the following procedures should have been performed.

- (a) When HET Tractor is received, inspect all items for damage that may have occurred during shipping and unloading operations. Pay close attention to any loose or missing nuts, bolts, screws, access plates, drain plugs, drain cocks, oil plugs, assemblies, subassemblies, or components that may be easily lost or broken in transit. Check Basic Issue Items (BI) against checklist to ensure all items are accounted for and in good condition. Carefully list all discrepancies (TM 9-2320-360-10-HR).

WARNING

Solvent cleaning compound MIL-PRF-680 Type II and III may be irritating to the eyes and skin. Use protective gloves and goggles. Use in well-ventilated areas. Use respirator as needed. Accidental ingestion can cause irritation of digestive tract and respiratory tract, may cause lung and central nervous system damage. Can be fatal if swallowed. Inhalation of high/massive concentrations can cause coma or be fatal. First aid for ingestion: do not induce vomiting. Seek immediate medical attention. First aid for skin contact: remove contaminated clothing. Wash skin thoroughly with soap and water. If symptoms persist, seek medical attention. First aid for eye contact: flush with water for 15 minutes or until irritation subsides. If symptoms persist, seek medical attention. First aid for inhalation: move to fresh air. If not breathing, provide artificial respiration. If symptoms persist, seek medical attention. Keep away from open flames and other sources of ignition. Failure to follow this warning may result in injury or death to personnel.

- The flashpoint for type II solvent cleaning compound is 141 -198°F (61 -92C) and type III is 200 -241°F (93 -116C).
- Improper cleaning methods and use of unauthorized cleaning solvents may injure personnel and damage equipment.
- Fire extinguishers should be placed nearby when using solvent cleaning compound. Failure to follow this warning may result in injury or death.
- Cloths or rags saturated with solvent cleaning compound must be disposed of IAW authorized facilities' procedures. Failure to follow this warning may result in injury.
- Eye shields must be worn when cleaning with a wire brush. Flying rust and metal particles may cause injury.

(b) Clean all exterior surfaces coated with rust-preventive compound with solvent cleaning compound.

(2) Special Procedures

(a) Activate battery if HET Tractor is delivered with dry-charged battery (TM 9-6140-200-14).

(a1) Connect batteries (para 7--61).

(b) Do the semiannual Preventive Maintenance Checks and Services (PMCS) (para 2--8).

(c) Lubricate specific points shown in LO 9-2320-360-12 regardless of interval. Do not lubricate gear cases or engine. Check processing tag for gear case and engine oil. If tag states the oil is good for 500 mi (805 km) of operation and is of the proper grade for local climatic operation, do not change oil.

(d) Schedule a semiannual service in accordance with DA Pam 750-8.

(e) HET Tractor Body and Sheet Metal

- Inspect body and sheet metal for evidence of damage during shipment.
- Check doors, latches, and hinges on compartments for proper operation.
- Check mounting hardware and tighten as necessary.

(f) HET Tractor Cab

- Inspect cab for evidence of damage during shipment.
- Inspect windshields and window glass for cracks or other damage.
- Check door latches, hinges, and windows for proper operation.
- Check seats and seat belts to see that they are securely installed, and that the operator's seat adjustments are functioning properly.

(g) Engine

- Remove any seals, plugs, or tape used to seal air inlets and ports on the engine during shipping.
- Check crankcase oil level with dipstick.
- Examine air cleaner element for dirty or restricted condition.
- Inspect engine and cooling hose connections for evidence of leakage.
- Clean away any obstruction to cooling air flow to radiator.

2-7. SERVICE BEFORE OPERATION (CONT)

WARNING

Radiator is very hot and pressurized during HET Tractor operation. Let radiator cool before removing cap. Be sure to wear the proper eye protection to avoid personal injury. Failure to comply may result in serious burns.

- Check radiator coolant. Check if solution is adequate for expected climatic conditions. Refer to TB 750-651 for preparation of antifreeze solutions. Put tag near filler cap with type of antifreeze and degree of protection written on tag.
 - Check engine starter wiring for loose connections and condition of wiring insulation.
- (h) Transmission
- Check fluid level with dipstick.
 - Check external lines for evidence of leakage.
- (i) Transfer Case
- Check level of lubricant at fill plug.
 - Inspect lubrication pump and external lines for evidence of leakage.
 - Check operation of two-speed shift mechanism.
 - Operate DRIVELINE control, observe drive power to front axle.
 - Inspect bolts on all driveline U-joints.
- (j) Electrical System
- Inspect battery cable connections, and clean and tighten as necessary.
 - Check all lights for burned out lamps, loose connections, and dirty or broken lenses.
 - Ensure that alternators are charging properly.
 - Ensure all electrical equipment functions.
 - Replace teflon tachograph chart with paper charts (para 7-15).
- (k) Air System
- Drain any water from reservoirs.
 - Inspect all accessible air hose and tubing connections for leakage.
- (l) Steering System
- Check steering hydraulic reservoir for proper fluid level.
 - Examine steering linkage and steering gears for damage incurred during shipment.
 - Examine steering hoses and connections for evidence of leakage.
 - Check steering system for proper operation during road test.
- (m) Chassis and Running-Gear
- Check all lubricant levels.
 - Check axle housing pressure vents to ensure freedom from foreign matter.

- (n) Tires
- Check tire inflation.
 - Inspect tires for serious cuts, bubbles, cracks, bruises, dry-rot, foreign objects, or exposure of internal cords. Remove foreign objects lodged in between tread.
 - Check all wheel mounting nuts for proper torque.
 - Check front and rear suspension for broken spring leaves, damaged components, or damaged air springs.
 - Check winch hydraulic reservoir sight glass for proper fluid level.
- (o) Fuel Systems
- Check fuel level and replenish, if necessary.
 - Inspect fuel lines, connections, and filters for evidence of leakage.

Section III. PREVENTIVE MAINTENANCE CHECKS AND SERVICES (PMCS)

2-8. PMCS INTRODUCTION

Table 2-1, PMCS has been provided so you can keep your equipment in good operating condition and ready for its primary mission. The PMCS in TM 9-2320-360-10, must be performed before doing unit PMCS. Lubricate in accordance with LO 9-2320-360-12, while performing checks and services. Operator PMCS will include a 10 mile minimum road test.

2-9. EXPLANATION OF COLUMNS

- a. Item Number Column. Numbers in this column shall be used as a source of item numbers for the TM Number Column on DA Form 2404 (Equipment Inspection and Maintenance Worksheet), in recording results of PMCS.
- b. Interval Column. The interval column tells you when to do a certain check or service. Semiannual PMCS must be performed every 6 months, and annual PMCS must be performed every 12 months.
- c. Item to be Inspected Column. This column tells you the item to be checked/serviced.
- d. Procedure Column. The procedure column of your PMCS table tells you how to do the required checks and services.
- e. Not Fully Mission Capable If: Column. This column tells you what faults will keep your HET Tractor from being capable of performing its primary mission. If you perform check and service procedures that show faults listed in this column, do not operate the HET Tractor. Follow standard operating procedures for maintaining the HET Tractor or reporting equipment failure.

2-10. GENERAL MAINTENANCE PROCEDURES

WARNING

Solvent cleaning compound MIL-PRF-680 Type II and III may be irritating to the eyes and skin. Use protective gloves and goggles. Use in well-ventilated areas. Use respirator as needed. Accidental ingestion can cause irritation of digestive tract and respiratory tract, may cause lung and central nervous system damage. Can be fatal if swallowed. Inhalation of high/massive concentrations can cause coma or be fatal. First aid for ingestion: do not induce vomiting. Seek immediate medical attention. First aid for skin contact: remove contaminated clothing. Wash skin thoroughly with soap and water. If symptoms persist, seek medical attention. First aid for eye contact: flush with water for 15 minutes or until irritation subsides. If symptoms persist, seek medical attention. First aid for inhalation: move to fresh air. If not breathing, provide artificial respiration. If symptoms persist, seek medical attention. Keep away from open flames and other sources of ignition. Failure to follow this warning may result in injury or death to personnel.

- The flashpoint for type II solvent cleaning compound is 141-198°F (61-92C) and type III is 200-241°F (93-116C).
 - Improper cleaning methods and use of unauthorized cleaning solvents may injure personnel and damage equipment.
 - Fire extinguishers should be placed nearby when using solvent cleaning compound. Failure to follow this warning may result in injury or death.
 - Cloths or rags saturated with solvent cleaning compound must be disposed of IAW authorized facilities' procedures. Failure to follow this warning may result in injury.
 - Eye shields must be worn when cleaning with a wire brush. Flying rust and metal particles may cause injury.
- a. Cleanliness. Dirt, grease, oil, and debris only get in the way and may cover up a serious problem. Use solvent cleaning compound (Item 31, Appendix C) on all metal surfaces and soapy water on rubber.

2-10. GENERAL MAINTENANCE PROCEDURES (CONT)

- b. Bolts, Nuts, and Screws. Check bolts, nuts, and screws for obvious looseness, and missing, bent, or broken conditions. Look for chipped paint, bare metal, or rust around bolt heads. If any part seems loose, tighten it. If any part is broken or missing, replace it.
- c. Welds. Look for loose or chipped paint, rust, or gaps where parts are welded together. If a bad weld is found, notify your supervisor.
- d. Electric Wires and Connectors. Look for cracked or broken insulation, bare wires, and loose or broken connectors. Tighten loose connectors and ensure wires are in good shape. If a bad wire or connector is found, notify your supervisor.
- e. Hydraulic Lines and Fittings. Look for wear, damage, and leaks; ensure clamps and fittings are tight. Wet spots show leaks. Stain around a fitting or connector can mean a leak. If a leak comes from a loose fitting or connector, tighten it. If something is broken or worn out, repair or replace it.
- f. Damage. Damage is defined as any condition that affects safety or would make the HET Tractor unserviceable for mission requirements.

2-11. FLUID LEAKAGE

- a. Leakage Definitions. Fluid leakage is classified and defined as follows:
 - Class I - Seepage of fluid (as indicated by wetness or discoloration) not great enough to form drops.
 - Class II - Leakage of fluid great enough to form drops but not enough to cause drops to fall from item being checked/inspected.
 - Class III - Leakage of fluid great enough to form drops that fall from the item being checked/inspected.

CAUTION

- Equipment operation is allowable with minor leakages (Class I or II). Of course, you must consider the fluid capacity in the item/system being checked/inspected. When in doubt, notify your supervisor.
- When operating with Class I or Class II leaks, continue to check fluid levels as required in your PMCS.
- Class III leaks should be reported to your supervisor and repaired.

2-12. PMCS TABLE

Refer to table 2-1 for unit PMCS procedures for the HET Tractor. Perform your PMCS (semiannual and annual) starting with the left front and continuing counterclockwise around the HET Tractor.

Table 2-1. Preventive Maintenance Checks and Services

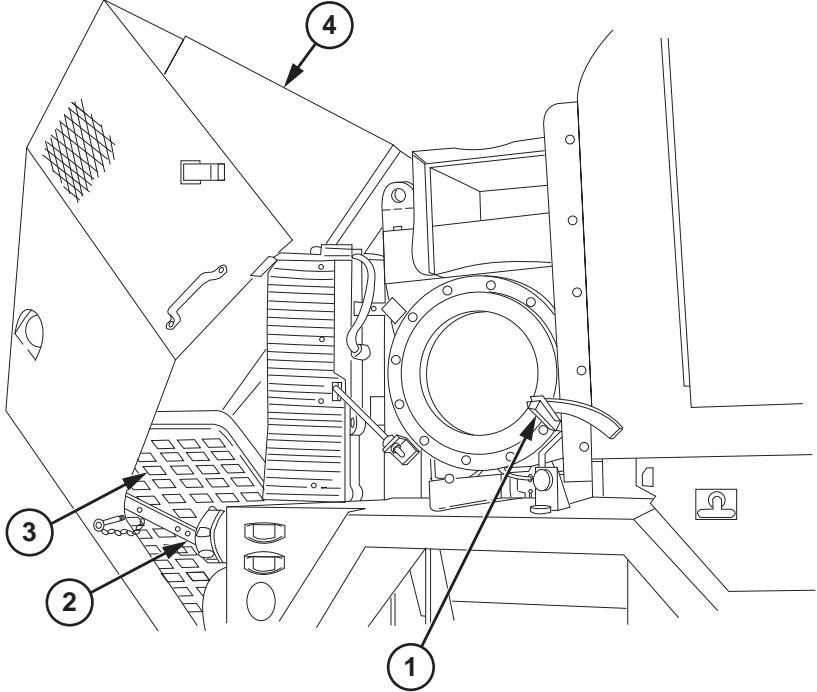
ITEM NO.	INTERVAL	ITEM TO BE CHECKED OR SERVICED	PROCEDURE	NOT FULLY MISSION CAPABLE IF:
1	Semi-annually	EXTERIOR	<p style="text-align: center;">NOTE</p> <p>Road test should be performed first.</p> <ol style="list-style-type: none"> a. Open hood (TM 9-2320-360-10). b. Check that fasteners (1), hinges (2), grille (3), and hood (4) are in place and serviceable. If faults are found, refer to hood repair (para 16-7). c. Check door hinge for damage and loose or missing mounting hardware. If fault is found, refer to door hinge replacement (para 16-5). 	<ol style="list-style-type: none"> b. Hinges or fasteners are broken.
				

Table 2-1. Preventive Maintenance Checks and Services (Cont)

ITEM NO.	INTERVAL	ITEM TO BE CHECKED OR SERVICED	PROCEDURE	NOT FULLY MISSION CAPABLE IF:
<p>1 (cont)</p>	<p>Semi-annually</p>	<p>EXTERIOR (CONT)</p>	<p>d. Check left rear fender (1) for cracks and loose or missing mounting hardware. If faults are found, refer to left rear fender replacement (para 16-30).</p> <p>e. Check right rear fender (2) for cracks and loose or missing mounting hardware. If faults are found, refer to right rear fender replacement (para 16-31).</p> <p>f. Lubricate doors, side panels, hood hinges, locks, latches, and pivot points.</p>	

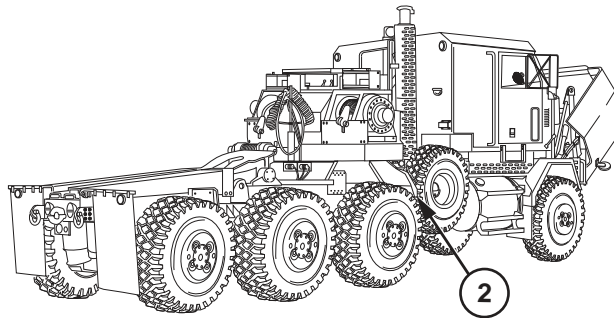
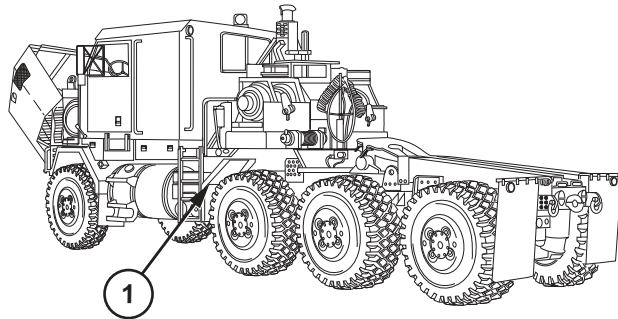


Table 2-1. Preventive Maintenance Checks and Services (Cont)

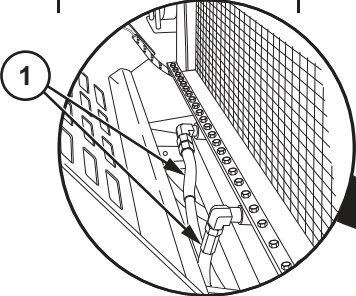
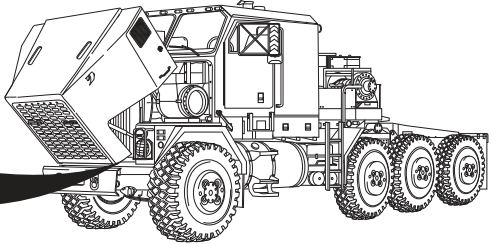
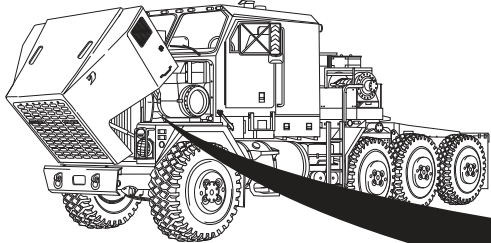
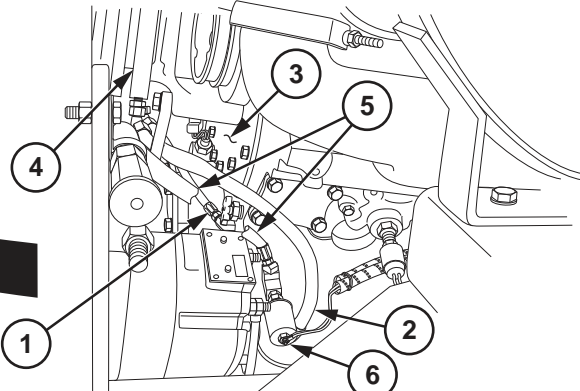
ITEM NO.	INTERVAL	ITEM TO BE CHECKED OR SERVICED	PROCEDURE	NOT FULLY MISSION CAPABLE IF:
2	Semi-annually	TRANSMISSION COOLING HOSES	Check transmission oil cooling hoses no. 2382 and no. 2393 (1) for cracks or leaks. If cooling hose is cracked or leaking, replace faulty part. Refer to transmission hose replacement (para 8-7).	Any class III leak is found. Hoses are cracked or frayed.
			 <p style="text-align: center;">WARNING</p> <p>Ensure engine is cool before performing maintenance. Be sure to wear the proper eye protection to avoid personal injury. Failure to comply may result in severe burns.</p>	
3	Semi-annually	ENGINE	<p>a. Check oil supply hose no. 2758 (1) and oil return hose no. 2761 (2) from engine (3) to fan clutch (4) for cracking or chafing. If faults are found, replace hose. Refer to fan clutch to engine block hose replacement (para 6-12).</p> <p>b. Check supply hose no. 2682 (5) from engine (3) to AOAP sampling valve (6) for cracks, leaks, or chafing. If faults are found, refer to AOAP sampling valve replacement (para 3-7).</p>	<p>a. Hose leaks or cracks or frays are found.</p> <p>b. Hose leaks or cracks or frays are found.</p>
				

Table 2-1. Preventive Maintenance Checks and Services (Cont)

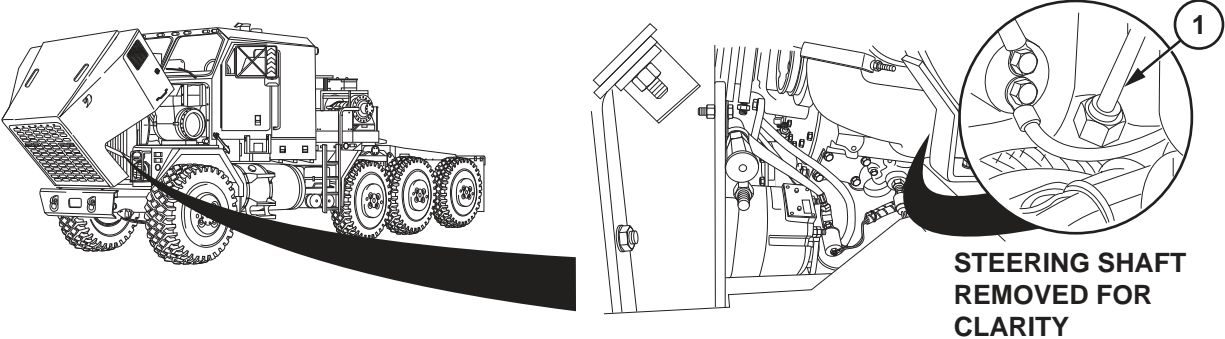
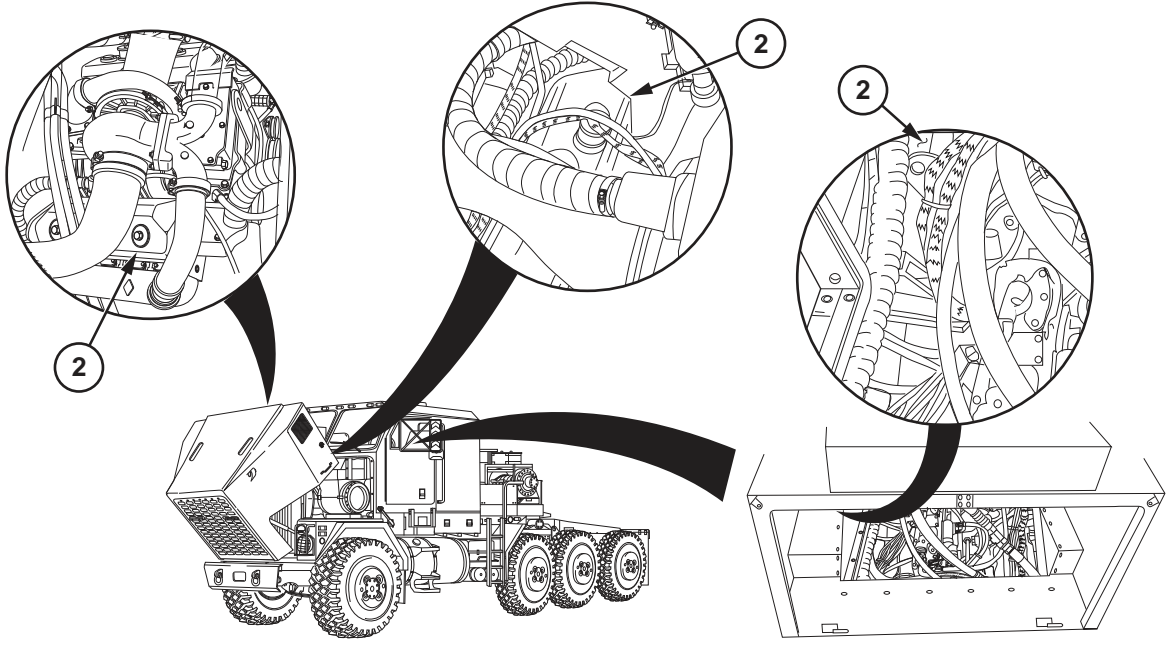
ITEM NO.	INTERVAL	ITEM TO BE CHECKED OR SERVICED	PROCEDURE	NOT FULLY MISSION CAPABLE IF:
3 (cont)	Semi-annually	ENGINE (CONT)	c. Check dipstick tube (1) for damage. If faults are found, replace dipstick tube (para 3-6).	c. Dipstick is broken or missing.
 <p>STEERING SHAFT REMOVED FOR CLARITY</p>				
<p>d. Check rocker covers (2) for leakage.</p>				
				

Table 2-1. Preventive Maintenance Checks and Services (Cont)

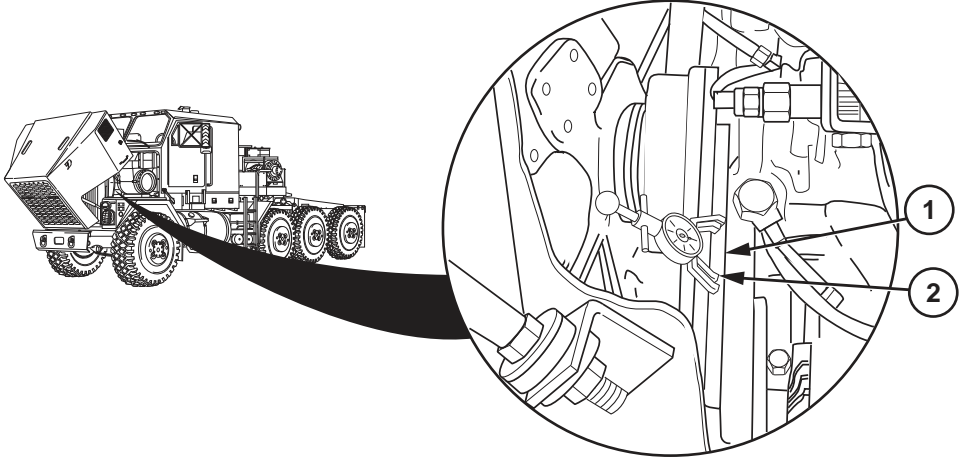
ITEM NO.	INTERVAL	ITEM TO BE CHECKED OR SERVICED	PROCEDURE	NOT FULLY MISSION CAPABLE IF:
3 (cont)	Semi-annually	ENGINE (CONT)	<p style="text-align: center;"><u>WARNING</u></p> <p>Remove rings, bracelets, watches, necklaces, and any other jewelry before working around HET Tractor. Jewelry can catch on equipment and cause injury or short across electrical circuit and cause severe burns or electrical shock. Batteries can explode from a spark. Battery acid is harmful to skin and eyes. Always wear eye protection when working with batteries.</p> <p>e. Check 24-volt alternator belts (1) for proper tension with belt tension gage (2). Belt tension gage reading should be 70-90 lb (310-400 N). If reading is not correct, adjust belts (para 7-7).</p>	<p>e. Belts are burned, cracked, ripped, frayed, or cut.</p>
				

Table 2-1. Preventive Maintenance Checks and Services (Cont)

ITEM NO.	INTERVAL	ITEM TO BE CHECKED OR SERVICED	PROCEDURE	NOT FULLY MISSION CAPABLE IF:
3 (cont)	Semi-annually	ENGINE (CONT)	<p>f. Check oil filter adapter (3) for leakage or damage. If fault is found, replace oil filter adapter and/or gasket (para 3-5).</p> <p>g. Check oil pan (4) for leaks or cracks. If faults are found, notify supervisor.</p>	g. Class III leak is found.
<p>The diagram shows a side view of a truck with a callout to the engine compartment. A circular inset provides a close-up of the oil filter adapter (3) and the oil pan (4). The oil filter adapter is a cylindrical component with a gasket, and the oil pan is a large, shallow metal tray below it.</p>				
<p style="text-align: center;"><u>WARNING</u> Ensure engine is cool before performing maintenance. Failure to comply may result in severe burns.</p>				
<p>h. Check turbocharger supply hose (1) and clamps (2) from turbocharger (3) to engine (4) for cracks, leaks, or chafing.</p> <p>h. Hose leaks or cracks or frays are found.</p> <p>The diagram shows a side view of the truck with a callout to the turbocharger area. A circular inset shows the turbocharger (3) connected to the engine (4) by a supply hose (1) with clamps (2). Another circular inset shows a close-up of the hose (1) and clamps (2) where they meet the engine (4).</p>				

Table 2-1. Preventive Maintenance Checks and Services (Cont)

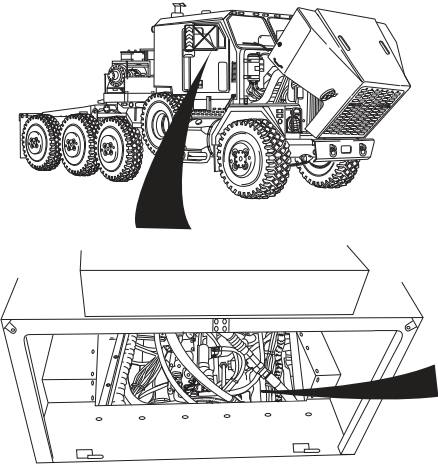
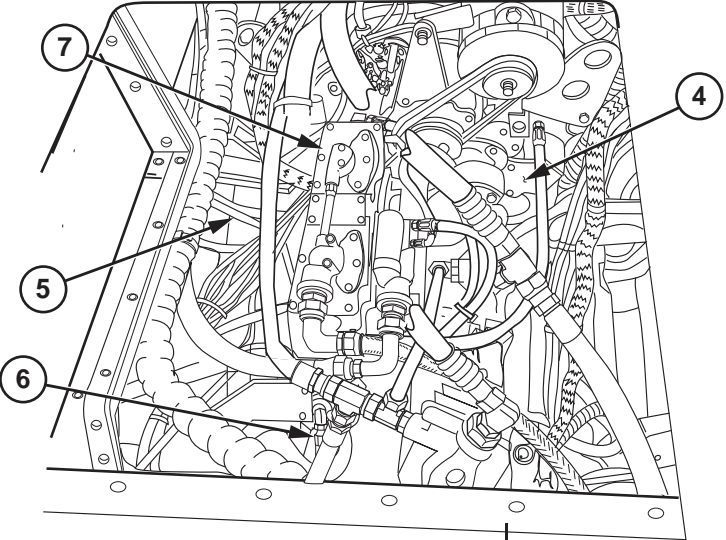
ITEM NO.	INTERVAL	ITEM TO BE CHECKED OR SERVICED	PROCEDURE	NOT FULLY MISSION CAPABLE IF:
<p>3 (cont)</p> 	<p>Semi-annually</p>	<p>ENGINE (CONT)</p>	<p>i. Check oil line no. 2630 (5) and oil line no. 2629 (6) from compressor (7) to engine (4) for cracks, leaks, or chafing. If faults are found, replace oil line (para 11-29).</p>  <p>j. Perform all semiannual lubrications as identified in LO 9-2320-360-12.</p>	<p>i. Oil line leaks or cracks or frays are found.</p>

Table 2-1. Preventive Maintenance Checks and Services (Cont)

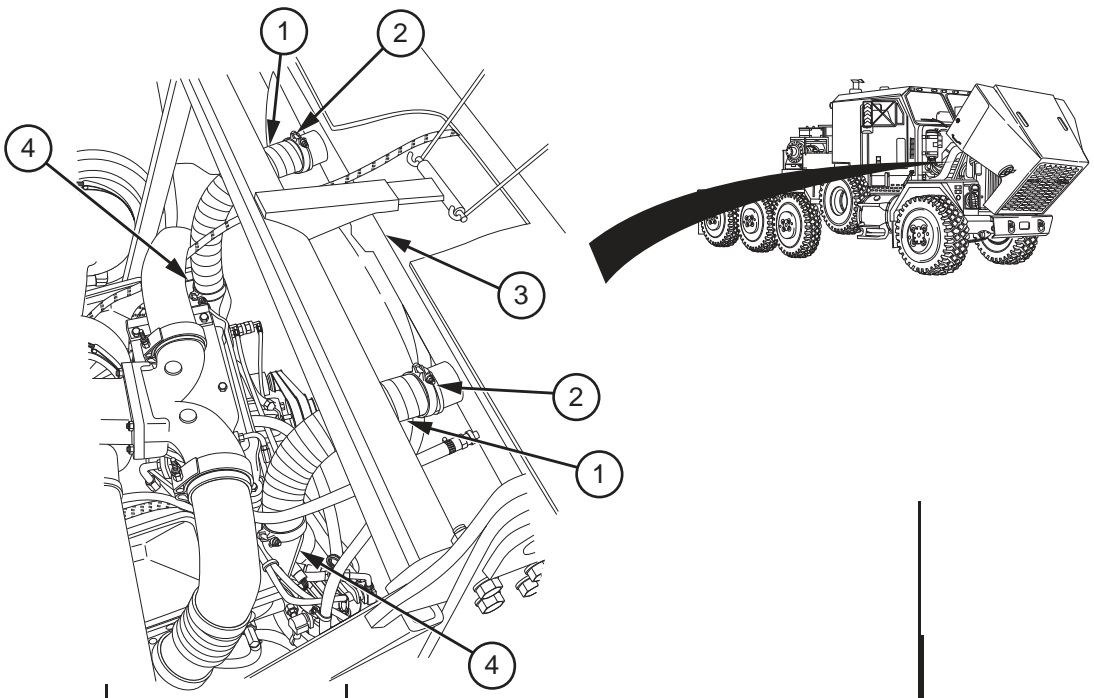
ITEM NO.	INTERVAL	ITEM TO BE CHECKED OR SERVICED	PROCEDURE	NOT FULLY MISSION CAPABLE IF:
4	Semi-annually	COOLING SYSTEM	<p style="text-align: center;"><u>WARNING</u></p> <p>Be sure to wear the proper eye protection to avoid personal injury.</p> <p>a. Check both upper hoses (1) and two clamps (2) from radiator (3) and thermostat covers (4). Tighten clamps to 25-35 lb-in. (2.8-4.0 N·m). If faults are found, replace hose/clamp (para 6-6).</p>	a. Hoses leak or cracks or frays are found.
				

Table 2-1. Preventive Maintenance Checks and Services (Cont)

ITEM NO.	INTERVAL	ITEM TO BE CHECKED OR SERVICED	PROCEDURE	NOT FULLY MISSION CAPABLE IF:
4 (cont)	Semi-annually	COOLING SYSTEM (CONT)	<p style="text-align: center;"><u>WARNING</u> Ensure engine is cool before performing maintenance. Failure to comply may result in severe burns.</p> <p>b. Check hose (1) and two clamps (2) from firewall to pipe (3) for cracks, leaks, or chafing. Tighten loose connections. If faults are found, replace hose/clamp (para 18-14).</p> <p>c. Deleted.</p> <p>d. Deleted.</p>	b. Hose leaks or cracks or frays are found.

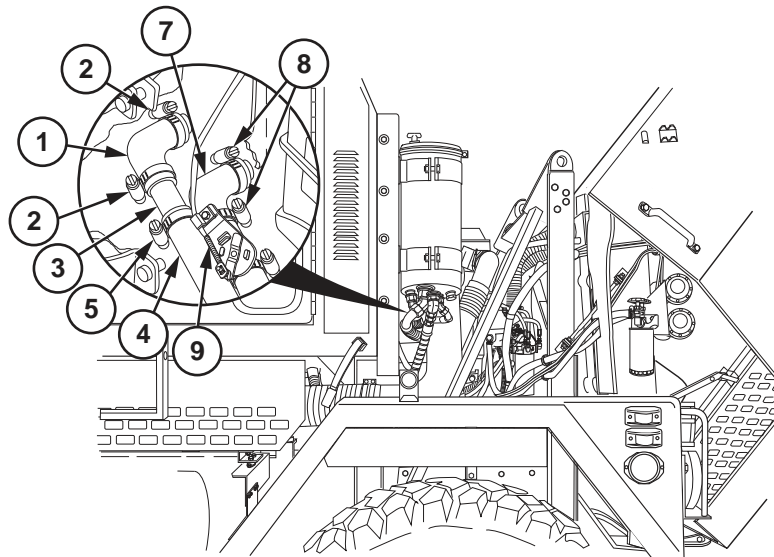


Table 2-1. Preventive Maintenance Checks and Services (Cont)

ITEM NO.	INTERVAL	ITEM TO BE CHECKED OR SERVICED	PROCEDURE	NOT FULLY MISSION CAPABLE IF:
4 (cont)	Semi-annually	COOLING SYSTEM (CONT)	<p>e. Check hose (1) and two clamps (2) from control valve to oil cooler (3) for cracks, leaks, or chafing. Tighten loose connections. If fault is found, replace hose/clamp (para 18-14).</p> <p>f. Check hose (4) and two clamps (5) from thermostat (6) to pipe (7) for cracks, leaks, or chafing. Tighten loose connections. If damaged, replace hose/clamp (para 18-14).</p>	<p>e. Hose leaks or cracks or frays are found.</p> <p>f. Hose leaks or cracks or frays are found.</p>

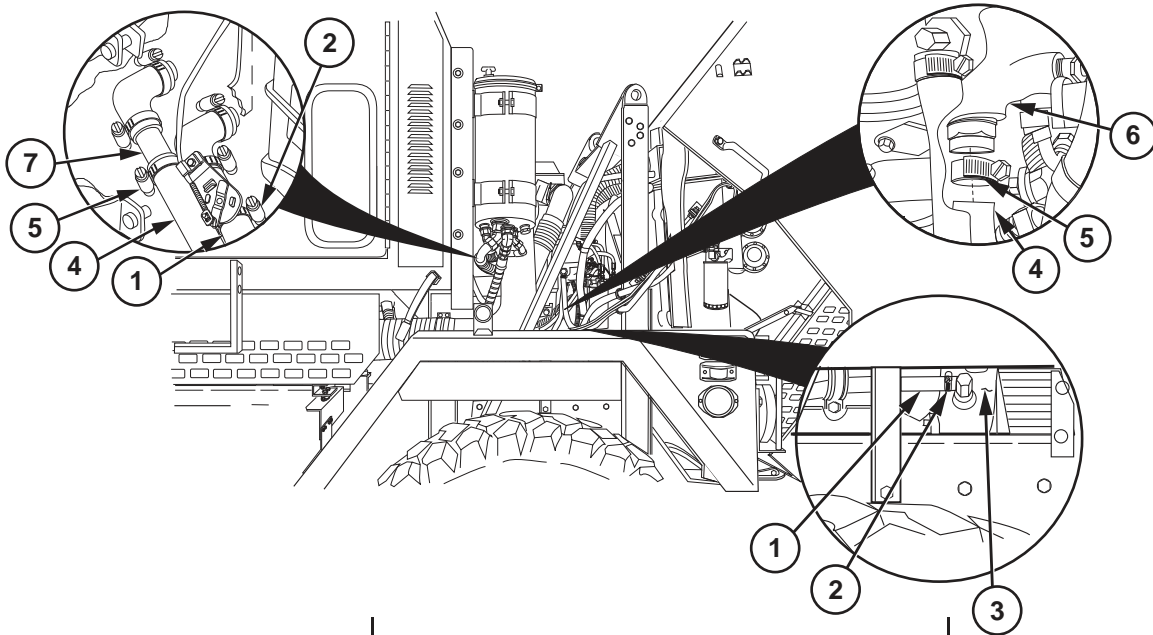


Table 2-1. Preventive Maintenance Checks and Services (Cont)

ITEM NO.	INTERVAL	ITEM TO BE CHECKED OR SERVICED	PROCEDURE	NOT FULLY MISSION CAPABLE IF:
4 (cont)	Semi-annually	COOLING SYSTEM (CONT)	<p>g. Check hose (1) and two clamps (2) for cracks, leaks, or chafing. Tighten loose connections. If fault is found, replace hose/clamp (para 6-6).</p> <p>h. Check hose (3) and two clamps (4) on inlet valve (5) of coolant filter mounting head for cracks, leaks, or chafing. Tighten loose connections. If fault is found, replace hose/clamp (para 6-6).</p> <p>i. Check hose (6) and two clamps (7) on outlet valve (8) of coolant filter mounting head for cracks, leaks, or chafing. Tighten loose connections. If fault is found, replace hose/clamp (para 6-6).</p>	<p>g. Hose leaks or cracks or frays are found.</p> <p>h. Hose leaks or cracks or frays are found.</p> <p>i. Hose leaks or cracks or frays are found.</p>

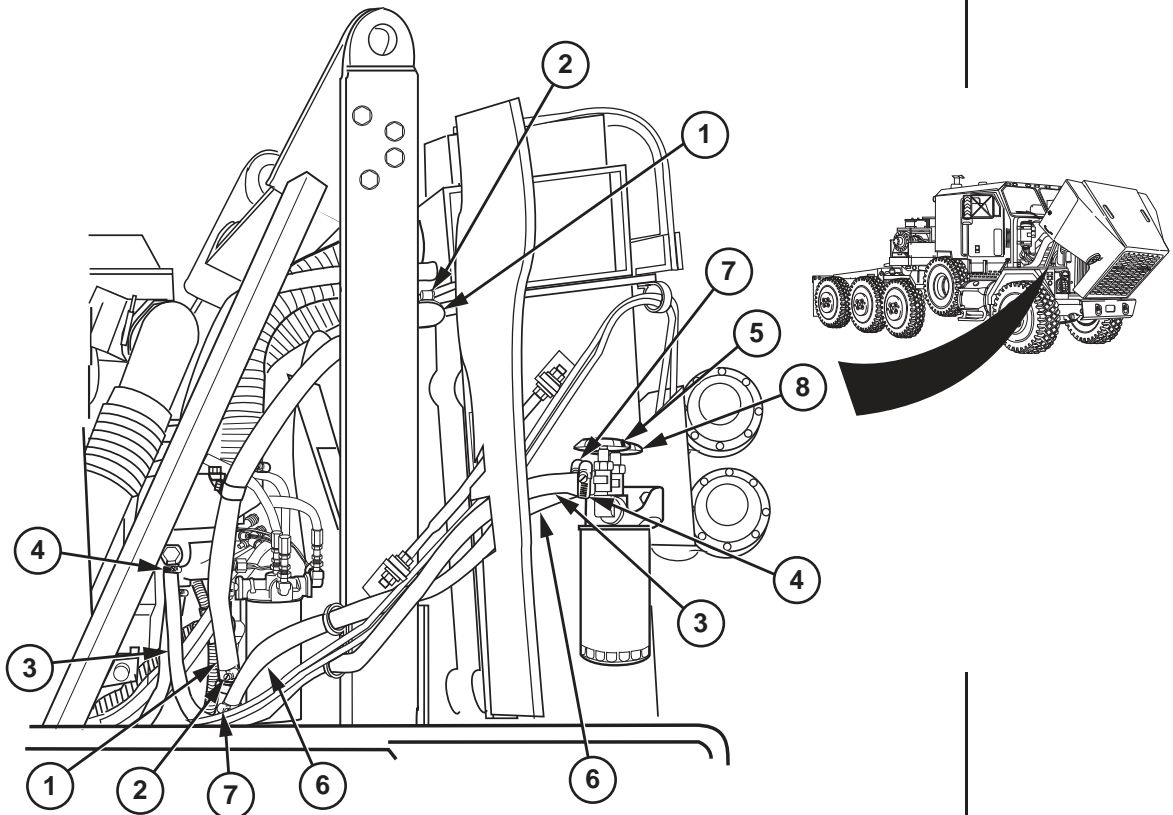


Table 2-1. Preventive Maintenance Checks and Services (Cont)

ITEM NO.	INTERVAL	ITEM TO BE CHECKED OR SERVICED	PROCEDURE	NOT FULLY MISSION CAPABLE IF:
4 (cont)	Semi-annually	COOLING SYSTEM (CONT)	<p>j. Check two lower hoses (1 and 2), two clamps (3), coolant tubes (4 and 5), and clamps (6) from water pump (7) and radiator (8) for cracks, leaks, or chafing. Tighten clamps to 25-35 lb-in. (2.8-4.0) N·m. If fault is found, replace hose/clamp (para 6-6).</p>	<p>j. Hoses leak or cracks or frays are found.</p>
			<p>k. Check radiator vent hose (9) and two clamps (10) for cracks, leaks, or chafing. Tighten loosen connections. If fault is found, replace hose/clamp (para 6-6).</p>	<p>k. Hose leaks or cracks or frays are found.</p>

Table 2-1. Preventive Maintenance Checks and Services (Cont)

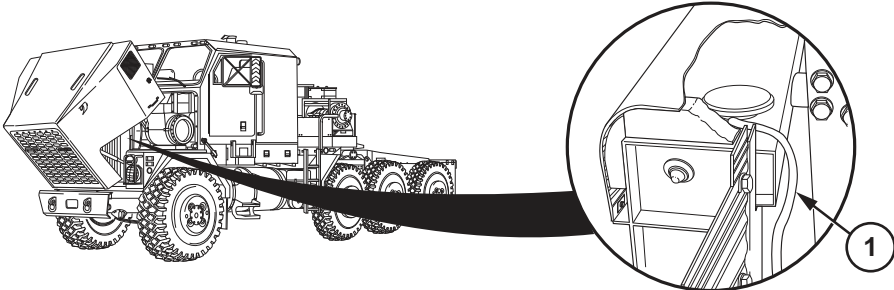
ITEM NO.	INTERVAL	ITEM TO BE CHECKED OR SERVICED	PROCEDURE	NOT FULLY MISSION CAPABLE IF:
4 (cont)	Semi-annually	COOLING SYSTEM (CONT)	<p style="text-align: center;"><u>WARNING</u> Ensure engine is cool before performing maintenance. Failure to comply may result in severe burns.</p> <p>i. Check overflow hose (1) for cracks or leaks. If fault is found, replace hose (para 6-3).</p> <div style="text-align: center;">  </div> <p>m. Test coolant for antifreeze protection, reserve alkalinity (corrosion protection), and cleanliness (para 6-2 and TB 750-651).</p> <p>n. Deleted.</p>	

Table 2-1. Preventive Maintenance Checks and Services (Cont)

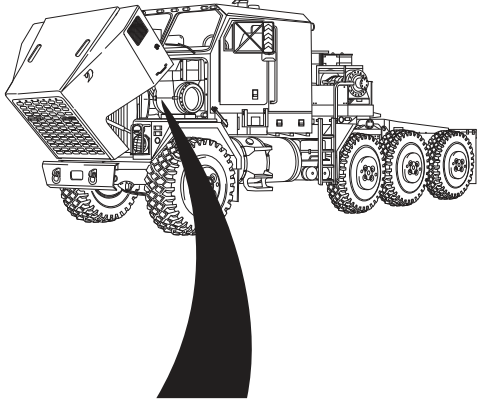
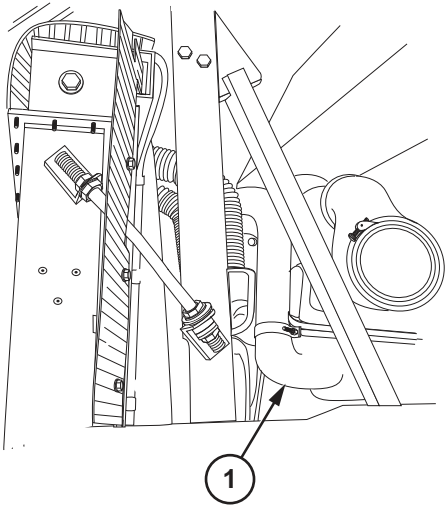
ITEM NO.	INTERVAL	ITEM TO BE CHECKED OR SERVICED	PROCEDURE	NOT FULLY MISSION CAPABLE IF:
<p>4 (cont)</p> <p>5</p>	<p>Semi-annually</p> <p>Semi-annually</p>	<p>COOLING SYSTEM (CONT)</p> <p>EXHAUST SYSTEM</p>	<p>o. Perform all semiannual lubrications as identified in LO 9-2320-360-12.</p> <p style="text-align: center;"><u>WARNING</u></p> <p>Engine is hot. Use caution when inspecting exhaust system. Failure to comply may result in severe burns.</p> <p>a. Check both exhaust manifolds (1) for leaks, cracks, and loose or missing mounting hardware.</p> <div style="text-align: center;">   </div>	<p>a. Any exhaust leaks are found.</p>

Table 2-1. Preventive Maintenance Checks and Services (Cont)

ITEM NO.	INTERVAL	ITEM TO BE CHECKED OR SERVICED	PROCEDURE	NOT FULLY MISSION CAPABLE IF:
5 (cont)	Semi-annually	EXHAUST SYSTEM (CONT)	<p style="text-align: center;"><u>WARNING</u></p> <p>The exhaust pipe and muffler can become very hot during HET Tractor operation. Do not touch these parts with bare hands or allow body to come in contact with pipe or muffler. Failure to comply may result in serious injury to personnel.</p> <p>b. Check exhaust pipes (1), muffler (2), and tail pipe (3) for cracks or leaks. If cracks or leaks are found, refer to chapter 5.</p> <p>c. Check mounting clamps (4) for looseness. Tighten loose clamps.</p> <p>d. Check rain cap (5) to ensure it operates freely and closes when engine is not running. If fault is found, replace rain cap (para 5-4).</p>	<p>b. Any leaks are found.</p> <p>d. Rain cap is missing.</p>

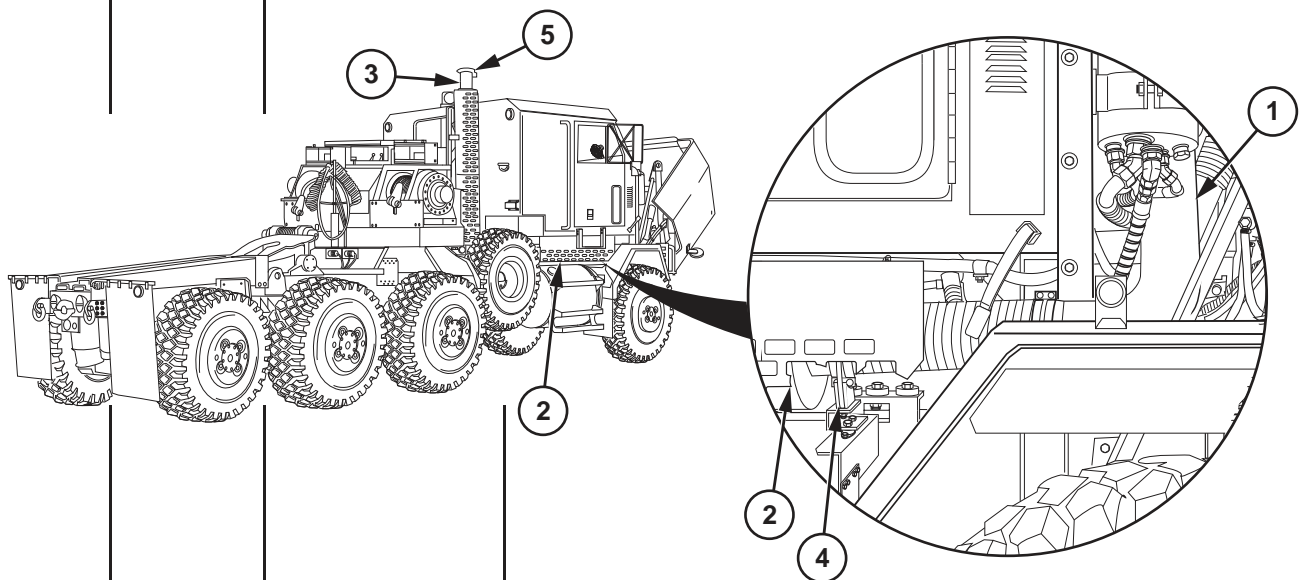


Table 2-1. Preventive Maintenance Checks and Services (Cont)

ITEM NO.	INTERVAL	ITEM TO BE CHECKED OR SERVICED	PROCEDURE	NOT FULLY MISSION CAPABLE IF:
6	Semi-annually	AIR INTAKE	<p style="text-align: center;">NOTE</p> <p>Engine must be running to perform this test.</p> <p>a. Check AIR CLEANER RESTRICTION indicator (1). Press reset button if indicator reads greater than 15. Service air cleaner (2) (para 4-2) if indicator still reads greater than 15 and will not reset.</p> <p>b. Check hoses (3) and ducting (4) for cracks, leaks, or chafing and loose or missing mounting hardware. Tighten loose connections. Replace damaged parts (para 4-3/4-4).</p>	<p>b. Any cracks or tears are in ducting or hose. Any hardware is missing.</p>

Table 2-1. Preventive Maintenance Checks and Services (Cont)

ITEM NO.	INTERVAL	ITEM TO BE CHECKED OR SERVICED	PROCEDURE	NOT FULLY MISSION CAPABLE IF:
7	Semi-annually	WHEELS AND TIRES	<p>a. Inspect for nicks, cuts, and gouges on tread and sidewalls. If tire is badly damaged, replace it (para 12-5).</p> <p style="text-align: center;">NOTE</p> <ul style="list-style-type: none"> • Tread depth measurements should be made at center of tread between the blocks that do not contain bridging. Bridging is a raised portion of rubber at the bottom of the groove that connects two or more blocks. • Three separate measurements must be taken. Measure depth across tread at outside edge, center, and inside edge. <p>b. Check tire (1) for wear using tire depth gage. Tread depth should not be less than 1/8 in. (3.2 mm).</p>	<p>a. Any two tires are missing. Tire out of round, flat, or cords are exposed.</p> <p>b. Tread depth is less than 1/8 in. (3.2 mm).</p>

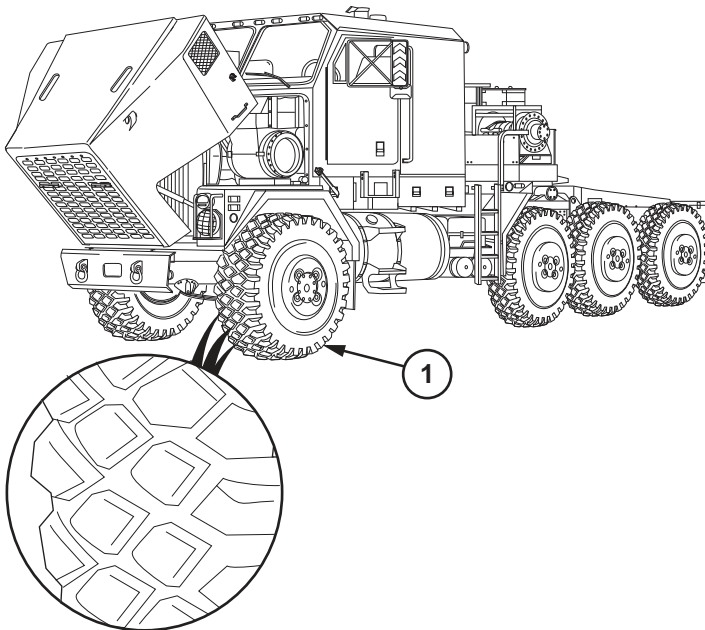


Table 2-1. Preventive Maintenance Checks and Services (Cont)

ITEM NO.	INTERVAL	ITEM TO BE CHECKED OR SERVICED	PROCEDURE	NOT FULLY MISSION CAPABLE IF:
7 (cont)	Semi-annually	WHEELS AND TIRES (CONT)	<p>c. Check wheels:</p> <ol style="list-style-type: none"> (1) Remove four nuts (1) and wheel cover (2) from wheel (3). <p style="text-align: center;"><u>WARNING</u></p> <p>Tire must be completely deflated before attempting to loosen nuts if any bolts are found loose or broken after removing wheel cover. Failure to comply may result in injury to personnel.</p> <ol style="list-style-type: none"> (2) Check wheels (3) and CTIS valves (4) for damage. (3) Tighten nuts (5) to 450–550 lb-ft (610–746 N·m). (4) Install wheel cover (2) on wheel (3) with four nuts (1). 	c. Nuts are missing.

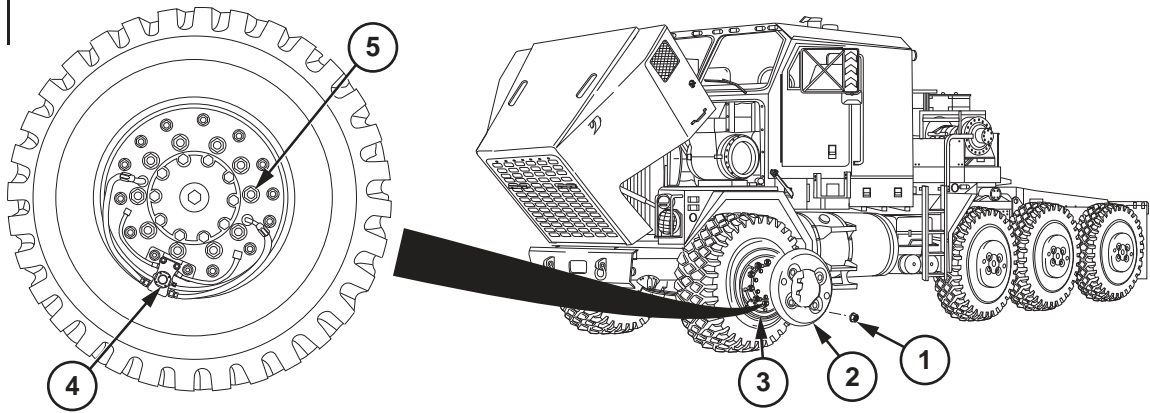


Table 2-1. Preventive Maintenance Checks and Services (Cont)

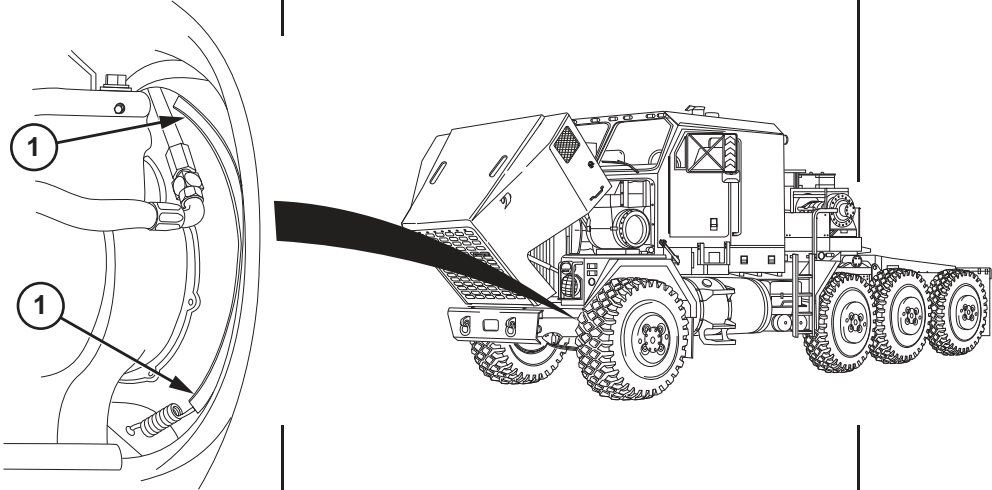
ITEM NO.	INTERVAL	ITEM TO BE CHECKED OR SERVICED	PROCEDURE	NOT FULLY MISSION CAPABLE IF:
8	Semi-annually	BRAKE SYSTEM	<p style="text-align: center;">NOTE</p> <p>Brake shoes, drums, and brake adjustment mechanisms must be cleaned of dirt, mud, and debris before inspection.</p> <p>a. Measure lining thickness of brake shoe (1). If brake lining is less than 9/32 in. (7 mm) at thinnest point, replace all brake shoes on axle (para 11-3).</p>  <p>b. Start engine and build system air pressure to 120-125 psi (827-862 kPa) (TM 9-2320-360-10).</p> <p>c. Shut off engine (TM 9-2320-360-10).</p>	<p>a. Brake linings are less than 9/32 in. (7 mm).</p>

Table 2-1. Preventive Maintenance Checks and Services (Cont)

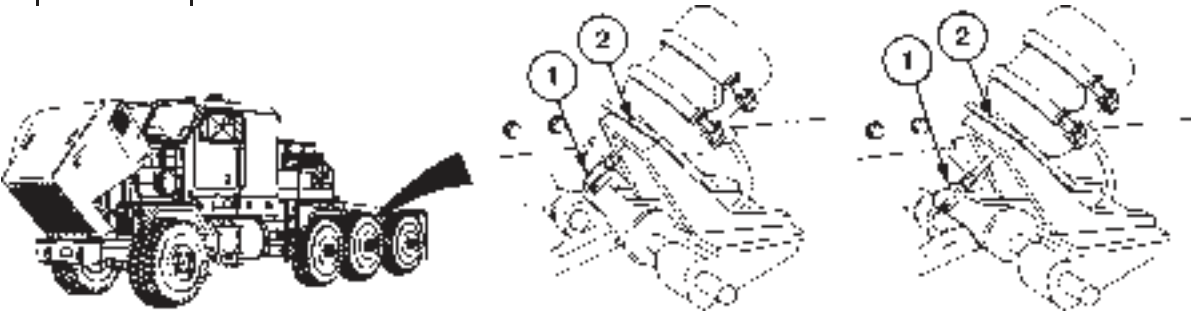
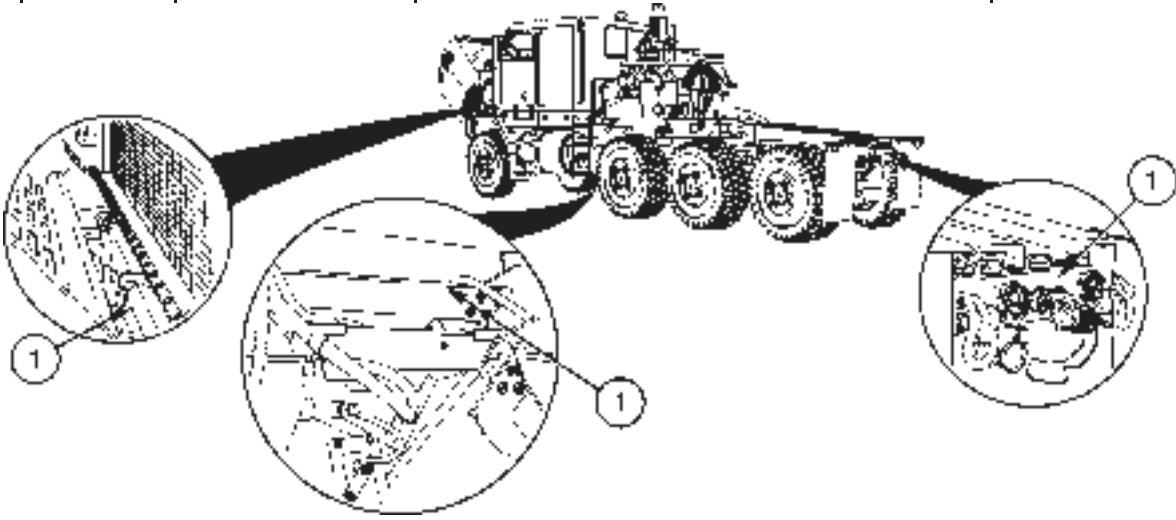
ITEM NO.	INTERVAL	ITEM TO BE CHECKED OR SERVICED	PROCEDURE	NOT FULLY MISSION CAPABLE IF:
8 (cont)	Semi-annually	BRAKE SYSTEM (CONT)	<p>d. Measure distance A between center of yoke pin (1) and chamber bracket (2) with brake treadle released. Record measurement.</p> <p>e. Measure distance B between center of yoke pin (1) and chamber bracket (2) while assistant holds brake treadle down. Record measurement.</p> <p>f. Subtract measurement A from measurement B. If difference is 2 in. (50 mm) or more, adjust manual slack adjuster (para 11-2) or troubleshoot automatic slack adjuster.</p>	f. Brakes are inoperative or cannot be adjusted.
				
9	Semi-annually	FRAME	Check frame crossmembers (1) for cracks, and loose or missing mounting hardware. If faults are found, notify supervisor.	Crossmembers are broken, loose, bent, or cracked or mounting hardware is
				

Table 2-1. Preventive Maintenance Checks and Services (Cont)

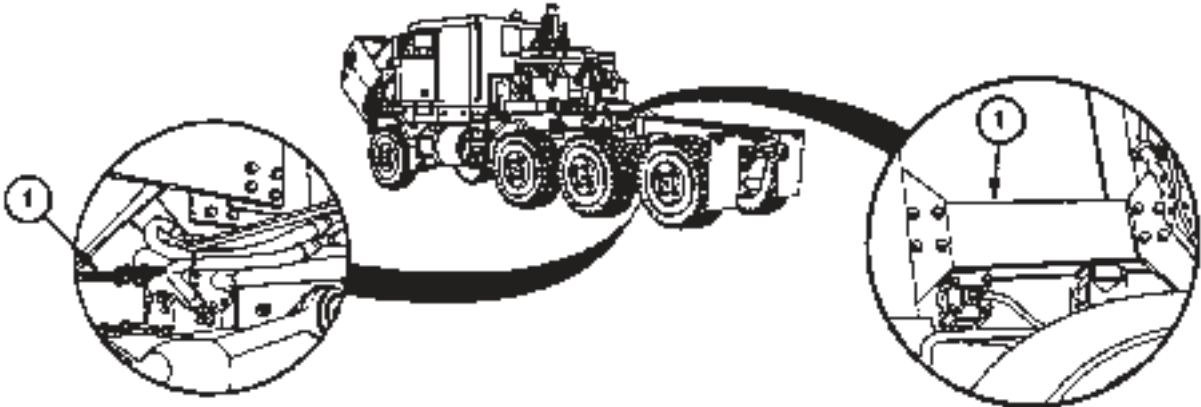
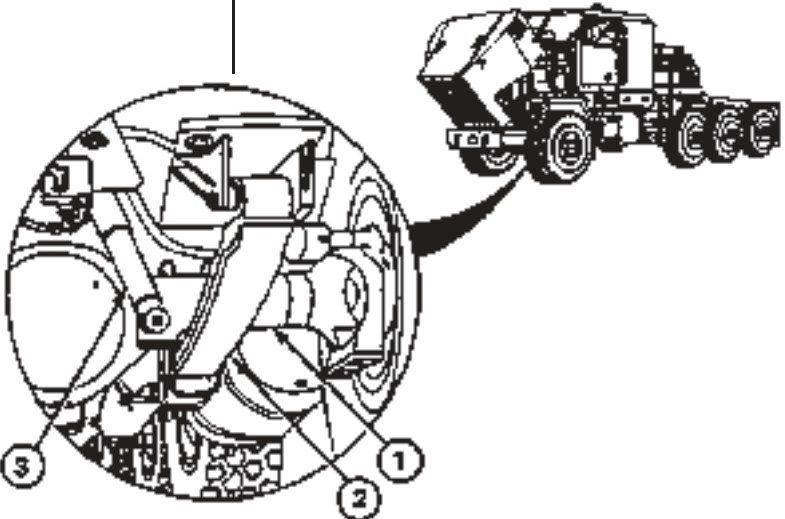
ITEM NO.	INTERVAL	ITEM TO BE CHECKED OR SERVICED	PROCEDURE	NOT FULLY MISSION CAPABLE IF:
<p>9 (cont)</p>	<p>Semi-annually</p>	<p>FRAME (CONT)</p>		
<p>10</p>	<p>Semi-Annually</p>	<p>AXLES/ SUSPENSION</p>	<p>a. Check front axle (1) for loose or missing mounting hardware.</p> <p style="text-align: center;">NOTE</p> <p>Some looseness of the front spring clip is permissible. The clip may rotate on the rivet.</p> <p>b. Check spring (2) for cracked or broken leaves or missing spring clips.</p> <p>c. Check shock absorber (3) for cracks, leaks, and loose or missing mounting hardware. If faults are found, replace shock absorber (para 15-3).</p> 	<p>a. Mounting hardware is missing.</p> <p>c. Shock absorber is cracked or broken or mounting hardware is missing.</p>

Table 2-1. Preventive Maintenance Checks and Services (Cont)

ITEM NO.	INTERVAL	ITEM TO BE CHECKED OR SERVICED	PROCEDURE	NOT FULLY MISSION CAPABLE IF:
10 (cont)	Semi-annually	AXLES/ SUSPENSION (CONT)	<p>d. Check no. 2, no. 3, and no. 4 axles (1) for loose or missing mounting hardware.</p> <p>e. Check air springs (2) for rips or tears.</p> <p>f. Check torque rods (3) for cracks and loose or missing mounting hardware. If faults are found, notify your supervisor.</p> <p>g. Check input and output shaft seals (4) for leakage (para 2-11).</p> <p>h. Check input and output yoke nuts (5) for looseness and proper staking. Both staked points or nuts should be in slots of pinion shafts.</p>	<p>d. Mounting hardware is missing.</p> <p>e. Air springs are ripped or torn.</p> <p>f. Torque rod or hardware is missing.</p> <p>g. Class III leak is found.</p> <p>h. Yoke nut(s) are loose, missing or not staked.</p>

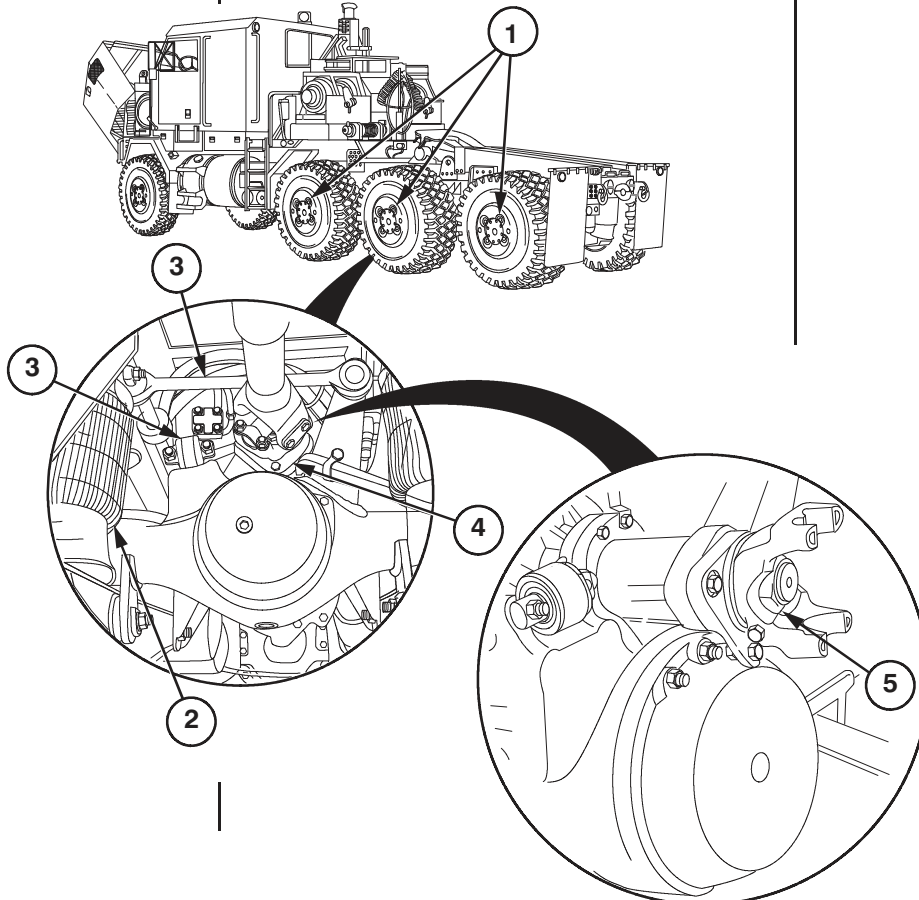


Table 2-1. Preventive Maintenance Checks and Services (Cont)

ITEM NO.	INTERVAL	ITEM TO BE CHECKED OR SERVICED	PROCEDURE	NOT FULLY MISSION CAPABLE IF:
10 (cont)	Semi-annually	AXLES/ SUSPENSION (CONT)	<p>h. Check wheel bearings for looseness:</p> <ol style="list-style-type: none"> (1) Raise vehicle from ground with suitable lifting device far enough to position crow bar between tire and ground. <p style="text-align: center;">NOTE</p> <p>Wheel should not be loose on hub.</p> <ol style="list-style-type: none"> (2) Brace crow bar on ground and push against tire. (3) If there is any wheel bearing play, notify your supervisor. 	<p>h. Wheel bearings are frozen, binding, or loose.</p> <p>Wheel bearing play is present. Any parts are missing.</p>

Table 2-1. Preventive Maintenance Checks and Services (Cont)

ITEM NO.	INTERVAL	ITEM TO BE CHECKED OR SERVICED	PROCEDURE	NOT FULLY MISSION CAPABLE IF:
10 (cont)	Semi-annually	AXLES/ SUSPENSION (CONT)	<p>i. Service axle breather:</p> <p style="text-align: center;">NOTE</p> <p>All axle breathers are serviced in a similar way. No. 2 axle breather is located at end of nylon tube coming from axle housing.</p> <p>(1) Check inside axle breather (1) for contamination. Ensure cap moves in and out freely.</p> <p style="text-align: center;">CAUTION</p> <p>Do not attempt to separate breather from adapter. Failure to comply may result in damage to breather.</p> <p style="text-align: center;">NOTE</p> <p>Do steps (2) thru (6) if axle breather is contaminated, stuck, or binding.</p> <p>(2) Remove axle breather (1) with adapter (1.1) from axle housing (2).</p>	i. Any breather missing or unservice-able.

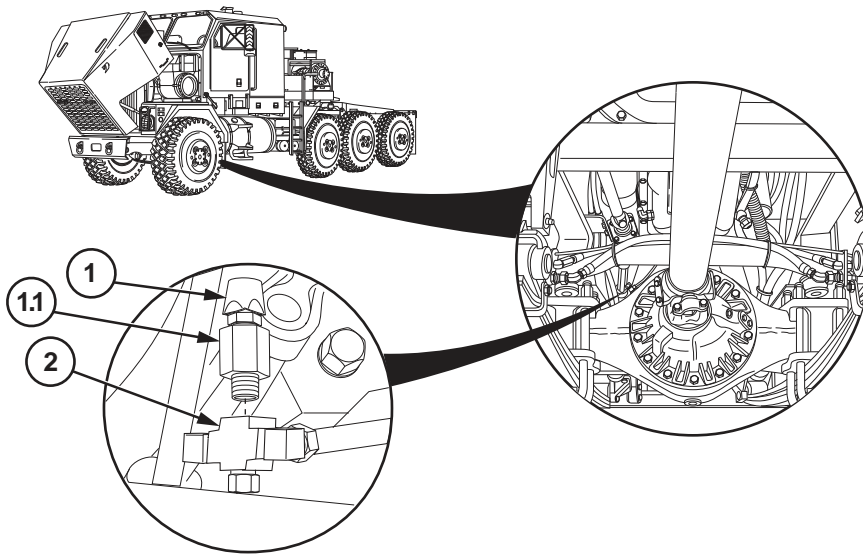


Table 2-1. Preventive Maintenance Checks and Services (Cont)

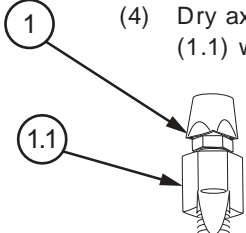
ITEM NO.	INTERVAL	ITEM TO BE CHECKED OR SERVICED	PROCEDURE	NOT FULLY MISSION CAPABLE IF:
10 (cont)	Semi-annually	AXLES/ SUSPENSION (CONT)	<p style="text-align: center;"><u>WARNING</u></p> <p>Solvent cleaning compound MIL-PRF 680 Type II and III may be irritating to the eyes and skin. Use protective gloves and goggles. Use in well-ventilated areas. Use respirator as needed. Accidental ingestion can cause irritation of digestive tract and respiratory tract, may cause lung and central nervous system damage. Can be fatal if swallowed. Inhalation of high/massive concentrations can cause coma or be fatal. First aid for ingestion: do not induce vomiting. Seek immediate medical attention. First aid for skin contact: remove contaminated clothing. Wash skin thoroughly with soap and water. If symptoms persist, seek medical attention. First aid for eye contact: flush with water for 15 minutes or until irritation subsides. If symptoms persist, seek medical attention. First aid for inhalation: move to fresh air. If not breathing, provide artificial respiration. If symptoms persist, seek medical attention. Keep away from open flames and other sources of ignition. Failure to follow this warning may result in injury or death to personnel.</p> <ul style="list-style-type: none"> •The flashpoint for type II solvent cleaning compound is 141-198°F (61-92C) and type III is 200-241°F (93-116C) •Improper cleaning methods and use of unauthorized cleaning solvents may injure personnel and damage equipment. •Fire extinguishers should be placed nearby when using solvent cleaning compound. Failure to follow this warning may result in injury or death. •Cloths or rags saturated with solvent cleaning compound must be disposed of IAW authorized facilities' procedures. Failure to follow this warning may result in injury. •Eye shields must be worn when cleaning with a wire brush. Flying rust and metal particles may cause injury <p>(3) Clean axle breather (1) and adapter (1.1) with solvent cleaning compound.</p>	
			<p style="text-align: center;"><u>WARNING</u></p> <p>Compressed air for cleaning purposes will not exceed 30 psi (207 kPa). Use only with effective chip guarding and personal protective equipment (goggles/shield, gloves, etc).</p> <p>(4) Dry axle breather (1) and adapter (1.1) with compressed air.</p> 	

Table 2-1. Preventive Maintenance Checks and Services (Cont)

ITEM NO.	INTERVAL	ITEM TO BE CHECKED OR SERVICED	PROCEDURE	NOT FULLY MISSION CAPABLE IF:
10 (cont)	Semi-annually	AXLES/ SUSPENSION (CONT)	<p style="text-align: center;">NOTE</p> <p>Do steps (4.1) and 4.2) only if breather or adapter are damaged.</p> <p>(4.1) Remove breather (1) from adapter (1.1).</p> <p style="text-align: center;"><u>WARNING</u></p> <p>Pipe thread sealing compound may burn or give off harmful vapors. It is harmful to skin and clothing. To avoid injury or death, keep away from open flame and use in well-ventilated area. If pipe thread sealing compound gets on skin or clothing, wash immediately with soap and water.</p> <p style="text-align: center;"><u>CAUTION</u></p> <p>Use pipe thread sealing compound sparingly only on pipe threads. Do not apply compound to hose connections. Failure to comply may result in component failure.</p> <p>(4.2) Coat threads of breather (1) with pipe thread sealing compound and install in adapter (1.1).</p> <p>(5) Coat threads of adapter (1.1) with pipe thread sealing compound.</p> <p>(6) Install breather (1) with adapter (1.1) in axle housing (2).</p>	

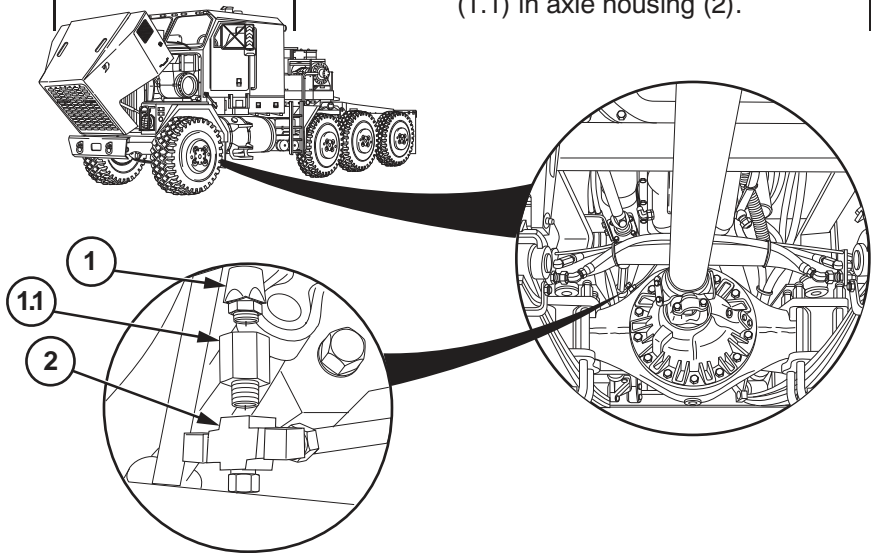


Table 2-1. Preventive Maintenance Checks and Services (Cont)

ITEM NO.	INTERVAL	ITEM TO BE CHECKED OR SERVICED	PROCEDURE	NOT FULLY MISSION CAPABLE IF:
11	Semi-annually	PROPELLER SHAFTS	<p>a. Check propeller shafts (1) for missing weights, grease fittings, screws, lock tabs, and leaking seals. If damage is found, repair propeller shaft (para 10-2).</p> <p style="text-align: center;">CAUTION</p> <p>Do not pry on grease fittings. Damage to equipment may result.</p> <p style="text-align: center;">NOTE</p> <p>To check universal joint play, position pry bar between yoke and propeller shaft. Apply pressure to pry bar and look for movement in universal joint.</p> <p>b. Check universal joints (2) for bearing play. If bearing play is found, repair propeller shaft (para 10-2).</p> <p>c. Perform all semiannual lubrications as identified in LO 9-2320-360-12.</p>	<p>a. Propeller shafts are loose. Weights, grease fittings, or screws are missing.</p>

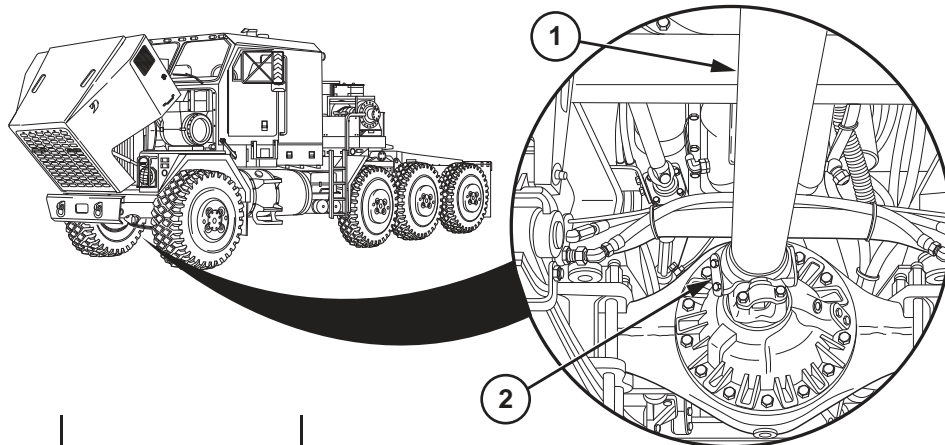


Table 2-1. Preventive Maintenance Checks and Services (Cont)

ITEM NO.	INTERVAL	ITEM TO BE CHECKED OR SERVICED	PROCEDURE	NOT FULLY MISSION CAPABLE IF:
12	Semi-annually	TRANSMISSION	<ul style="list-style-type: none"> a. Check transmission (1) and oil pan (2) for loose mounting hardware or leakage. b. Check drain plug (3) for looseness. c. Check output shaft oil seal (4) for leakage (para 2-11). d. Check transmission shift cable (5) for kinks, frays, or broken linkage. If faults are found, replace shift cable (para 2-11). e. Perform all semiannual lubrications as identified in LO 9-2320-360-12. 	<ul style="list-style-type: none"> a. Class III leaks are present or mounting hardware is missing. c. Class III leaks are present. d. Cable is broken, kinked, or frayed, or linkage is broken.

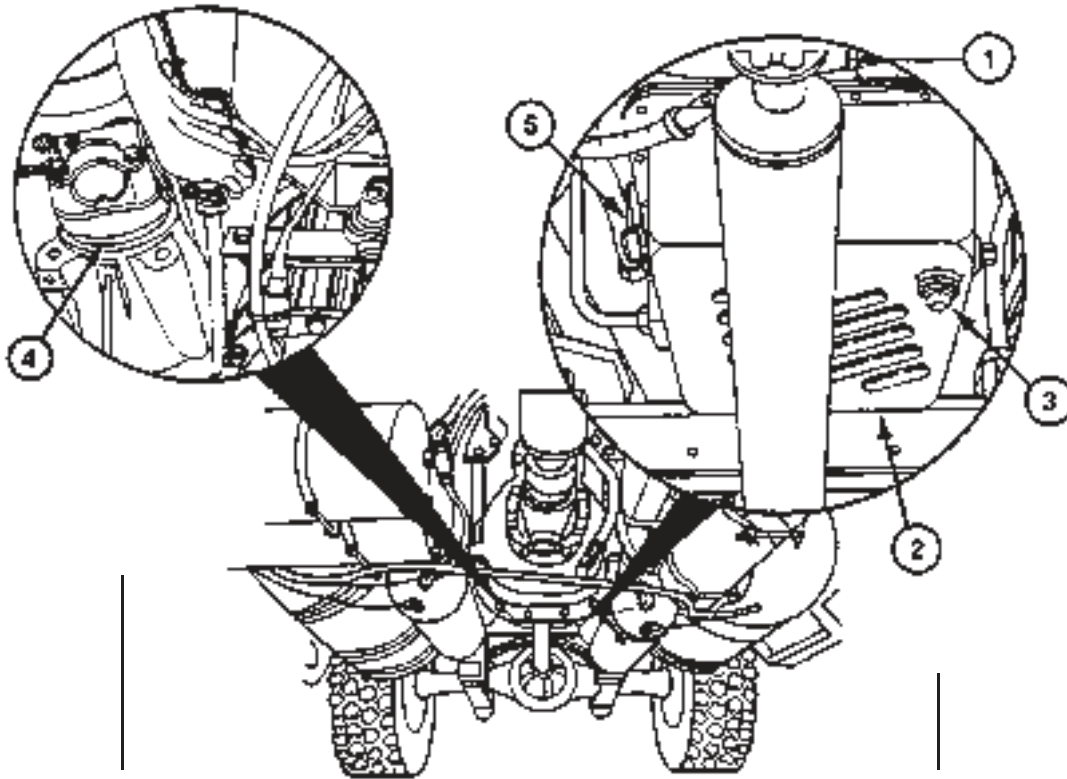


Table 2-1. Preventive Maintenance Checks and Services (Cont)

ITEM NO.	INTERVAL	ITEM TO BE CHECKED OR SERVICED	PROCEDURE	NOT FULLY MISSION CAPABLE IF:
13	Semi-annually	TRANSFER CASE	<ul style="list-style-type: none"> a. Check transfer case (1) for cracks and loose or missing mounting hardware. b. Check transfer case input and output shaft seals (2) for leaks (para 2-11). c. Check transfer case shift cable (3) for kinks, frays, or broken linkage. If faults are found, replace shift linkage (para 9-2). d. Perform all semiannual lubrication as identified in LO 9-2320-360-12. 	<ul style="list-style-type: none"> a. Mounting hardware is missing. b. Any class III leaks are found. c. Cable is broken, kinked, or frayed, or linkage is broken.

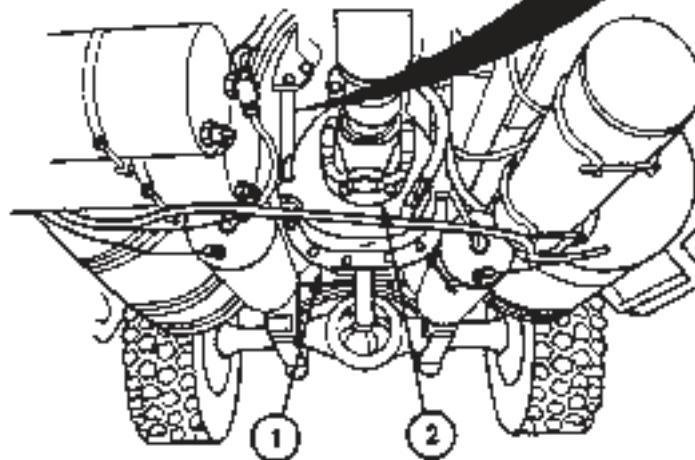
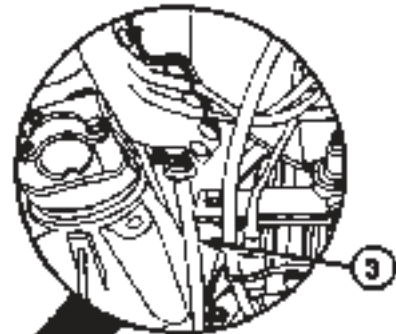


Table 2-1. Preventive Maintenance Checks and Services (Cont)

ITEM NO.	INTERVAL	ITEM TO BE CHECKED OR SERVICED	PROCEDURE	NOT FULLY MISSION CAPABLE IF:
14	Semi-annually	AIR SYSTEM	<ul style="list-style-type: none"> a. Start engine and build up air pressure to 120-125 psi (827-862 psi). b. Shut off engine (TM 9-2320-360-10). c. Coat fittings with soapy water. d. Check air reservoirs (1), valves (2), and air lines (3) for cracks or leaks. Tighten loose connections. e. Drain air reservoirs (1). Check for presence of oil. If oil is present, notify supervisor. 	<ul style="list-style-type: none"> d. Any leaks are found. e. Oil is present.
15	Semi-annually	STEERING SYSTEM	<ul style="list-style-type: none"> a. Check front steering gear (1) for leaks and loose or missing mounting hardware. b. Check front steering shafts (2) and U-joints (3) for cracks and loose or missing mounting hardware. If fault is found, refer to steering shaft repair (para 13-6). 	<ul style="list-style-type: none"> a. Class III leaks are found or mounting hardware is missing. b. U-joints are loose. Bearing caps are cracked or missing.

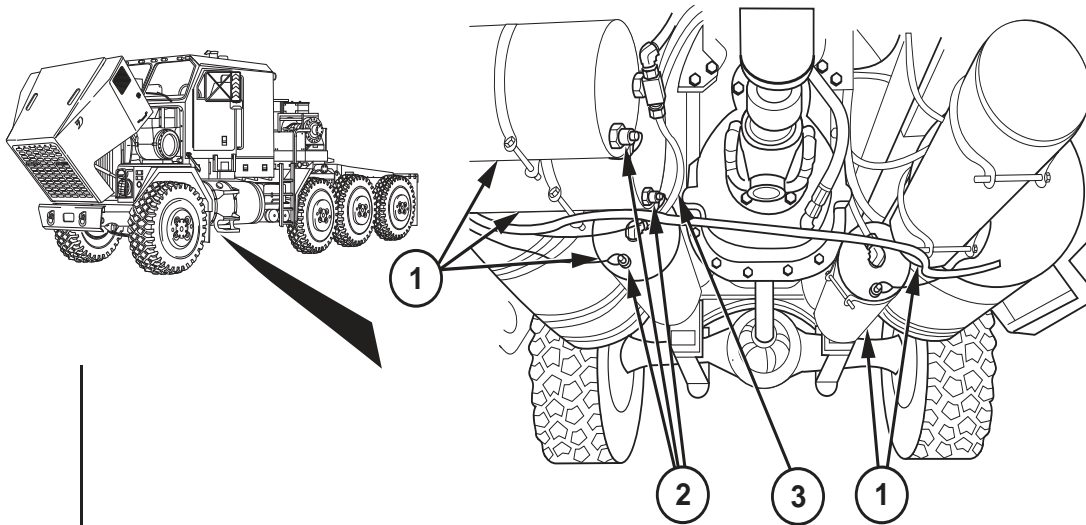


Table 2-1. Preventive Maintenance Checks and Services (Cont)

ITEM NO.	INTERVAL	ITEM TO BE CHECKED OR SERVICED	PROCEDURE	NOT FULLY MISSION CAPABLE IF:
<p>15 (cont)</p>	<p>Semi-annually</p>	<p>STEERING SYSTEM (CONT)</p>	<p>b.1. Check front drag link ends (1) for excessive wear, refer to drag link inspection (para 13-14.1).</p> <p>c. Check front drag link (1) and pitman arm (2) for cracks and loose or missing mounting hardware.</p> <p>d. Check tee gear box (3) for cracks and loose or missing mounting hardware. If fault is found, refer to tee gear box replacement (para 13-8).</p>	<p>b.1. Excessive wear on drag link ends.</p> <p>c. Pitman arm is cracked or ripped or mounting hardware is missing.</p> <p>d. Tee gear box is cracked or mounting hardware is missing.</p>

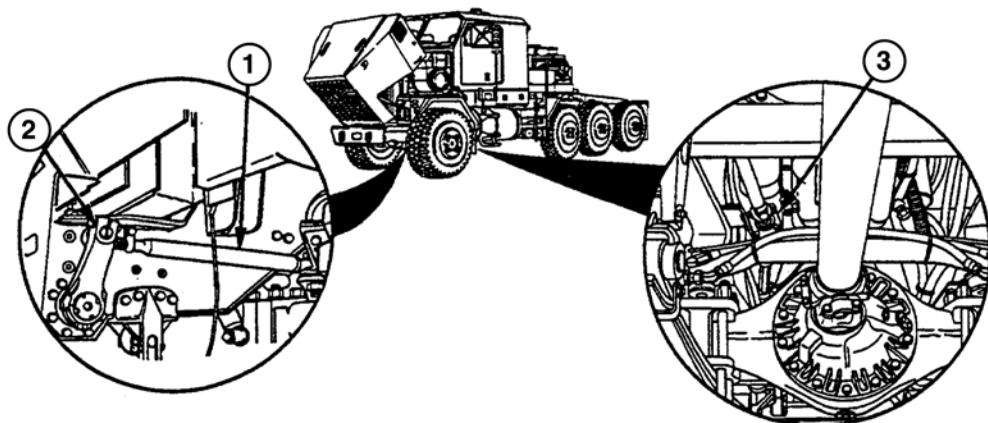
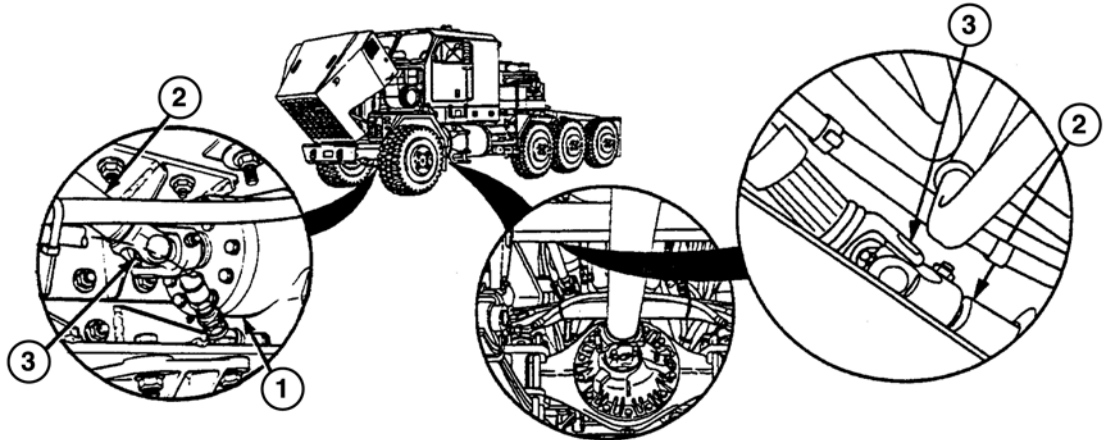


Table 2-1. Preventive Maintenance Checks and Services (Cont)

ITEM NO.	INTERVAL	ITEM TO BE CHECKED OR SERVICED	PROCEDURE	NOT FULLY MISSION CAPABLE IF:
15 (cont)	Semi-annually	STEERING SYSTEM (CONT)	<p>d.1. Check front tie rod ends (1) for excessive wear, refer to tie rod inspection (para 13-4.1).</p> <p>e. Check front tie rod (1) for cracks and loose or missing mounting hardware. If fault is found, refer to tie rod replacement (para 13-4).</p> <p>f. Check front steering lines and hoses (2) for cracks, leaks, or rotting. If faults are found, replace faulty part (para 13-9/13-10).</p>	<p>d.1. Excessive wear on tie rod ends.</p> <p>e. Cracks are found or mounting hardware is missing.</p> <p>f. Any leaks are found.</p>
			<p>g. Check rear steering gear (1) for leaks and loose or missing mounting hardware.</p> <p>h. Check rear steering shafts (2) and U-joints (3) for cracks and loose or missing mounting hardware. If damage is found, repair steering system shaft (para 13-7).</p> <p>i. Check rear steering lines (4) and hoses (5) for cracks, leaks, or rotting. If faults are found, replace faulty part (para 13-9/13-10).</p>	<p>g. Class III leaks are found or mounting hardware is missing.</p> <p>h. U-joints are loose. Bearing caps are cracked or missing.</p> <p>i. Any leaks are found.</p>

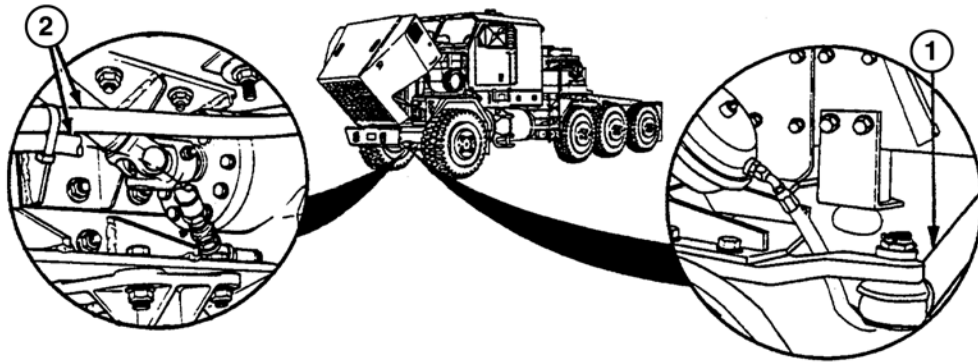


Table 2-1. Preventive Maintenance Checks and Services (Cont)

ITEM NO.	INTERVAL	ITEM TO BE CHECKED OR SERVICED	PROCEDURE	NOT FULLY MISSION CAPABLE IF:
<p>15 (cont)</p>	<p>Semi-annually</p>	<p>STEERING SYSTEM (CONT)</p>	<p>i.1. Check rear drag link ends (6) for excessive wear, refer to drag link inspection (para 13-4.1).</p> <p>j. Check rear drag link (6) and pitman arm (7) for cracks and loose or missing mounting hardware.</p> <p>j.1. Check rear tie rod ends (8) for excessive wear, refer to tie rod inspection (para 13-4.1).</p> <p>k. Check rear tie rod (8) for cracks and loose or missing mounting hardware. If fault is found, refer to tie rod replacement (para 13-4).</p> <p>l. Perform semiannual lubrication as identified in LO 9-2320-360-12.</p>	<p>i.1. Excessive wear on drag link ends.</p> <p>j. Pitman arm is cracked or ripped or mounting hardware is missing.</p> <p>j.1. Excessive wear on tie rod ends.</p> <p>k. Cracks are found or mounting hardware is missing.</p>

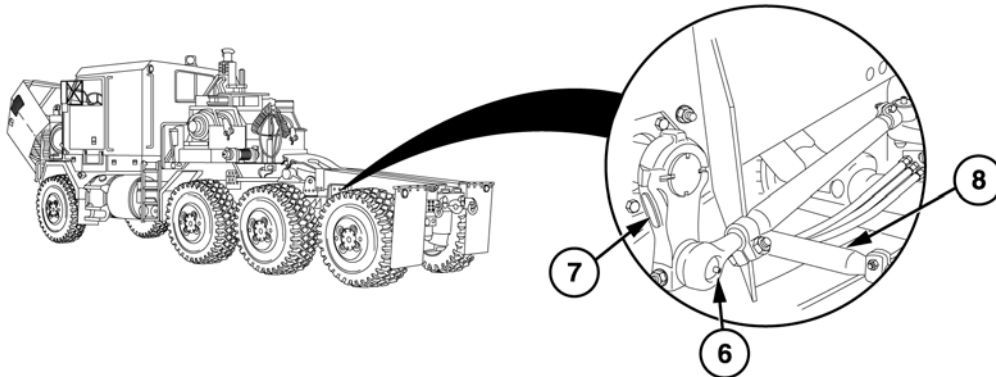
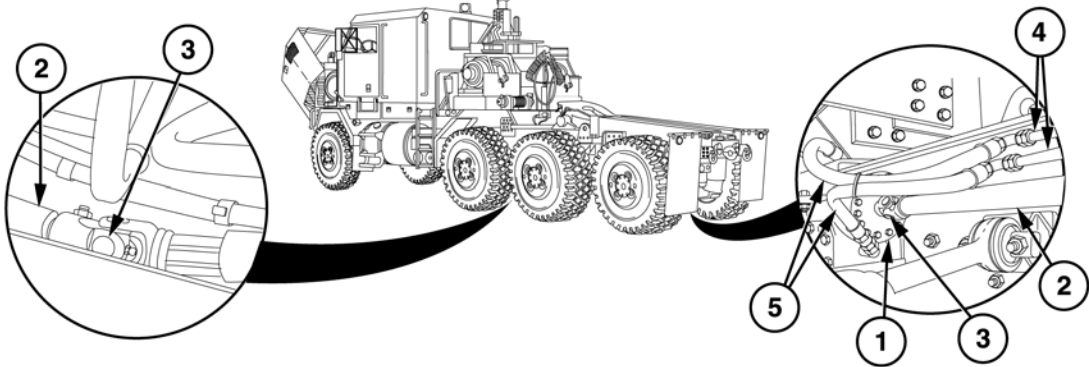


Table 2-1. Preventive Maintenance Checks and Services (Cont)

ITEM NO.	INTERVAL	ITEM TO BE CHECKED OR SERVICED	PROCEDURE	NOT FULLY MISSION CAPABLE IF:
16	Semi-annually	FUEL SYSTEM	a. Service fuel/water separator (para 4-11). b. Replace secondary fuel filter (para 4-13).	a. Class III leak is found.
17	Semi-annually	BATTERIES	<p style="text-align: center;">WARNING</p> <p>Remove rings, bracelets, watches, necklaces, and any other jewelry before working around HET Tractor. Jewelry can catch on equipment and cause injury or short across electrical circuit and cause severe burns or electrical shock. Batteries can explode from a spark. Battery acid is harmful to skin and eyes. Always wear eye protection when working with batteries.</p> <p>a. Open battery box (TM 9-2320-360-10).</p> <p style="text-align: center;">NOTE</p> <p>Make a separate test for each battery cell.</p> <p>b. Check and record specific gravity of each cell using antifreeze and battery tester (Item 49, Appendix F):</p> <ol style="list-style-type: none"> (1) Using black dipstick, place a few drops of electrolyte on exposed portion of measuring window. (2) Point tester toward a bright light source. 	b. Any cell gravity reading is below 1.225 (tropical batteries, 1.180).

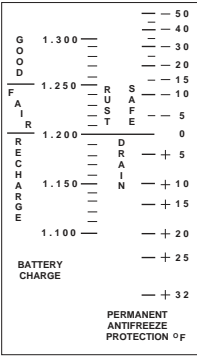
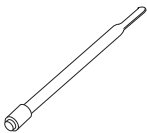
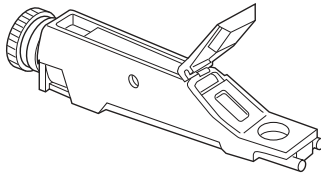
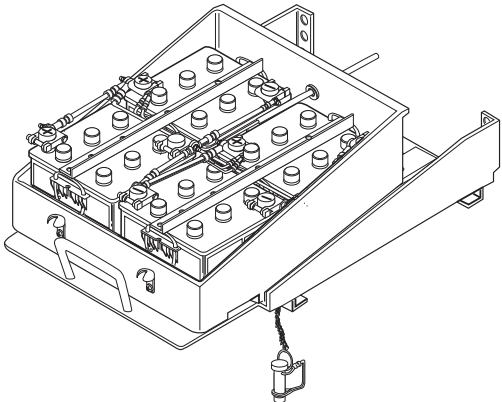


Table 2-1. Preventive Maintenance Checks and Services (Cont)

ITEM NO.	INTERVAL	ITEM TO BE CHECKED OR SERVICED	PROCEDURE	NOT FULLY MISSION CAPABLE IF:
17 (cont)	Semi-annually	BATTERIES (CONT)	<p style="text-align: center;">NOTE</p> <ul style="list-style-type: none"> • Batteries prepared for a tropical climate will have a 1 in. (25 mm) diameter white spot painted on battery top. • Full charge is 1.225 specific gravity for tropical batteries and 1.280 specific gravity for all others. <ul style="list-style-type: none"> (3) Record specific gravity of each cell. (4) Test alternator output (para 7-2) if specific gravity is below 1.180 for tropical batteries and 1.225 for all others. c. Remove batteries (1) from battery box (2) (para 7-57). Replace battery if specific gravity is below 1.180 for tropical batteries and 1.225 for all others d. Check battery box (2) for cracks and debris. Clean battery box (para 2-17). If damaged, replace battery box (para 7-57). 	

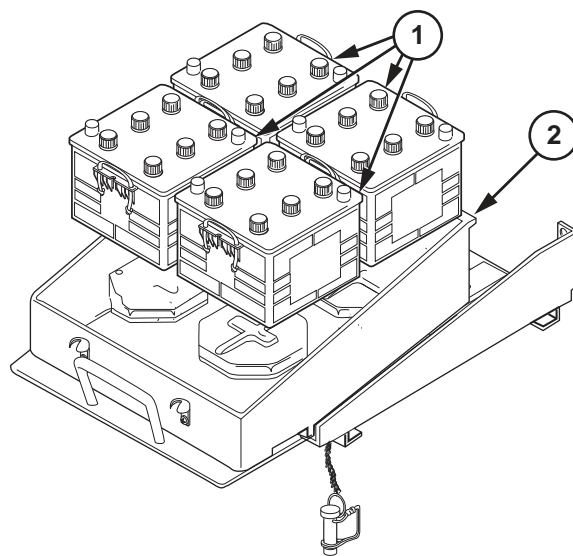


Table 2-1. Preventive Maintenance Checks and Services (Cont)

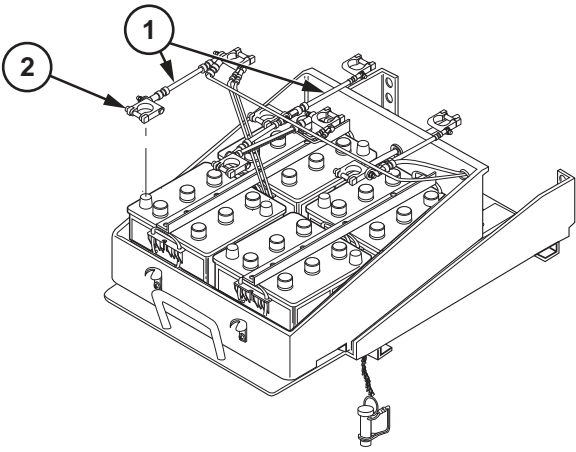
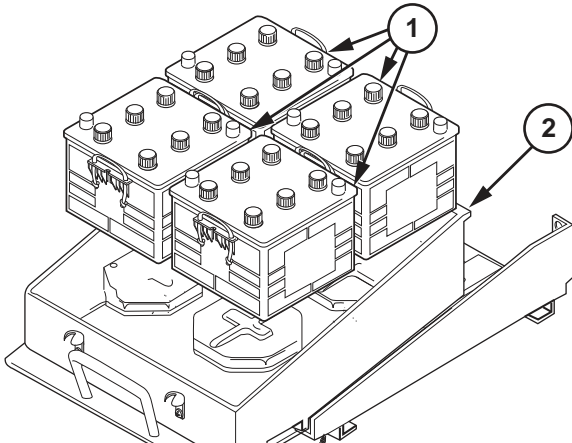
ITEM NO.	INTERVAL	ITEM TO BE CHECKED OR SERVICED	PROCEDURE	NOT FULLY MISSION CAPABLE IF:
17 (cont)	Semi-annually	BATTERIES (CONT)	<p>e. Check battery cables (1) for frays and splits. Check terminals (2) for looseness. Clean and apply anticorrosion grease to battery connections. If faults are found, replace battery cables and terminals (para 7-57).</p>  <p>f. Install batteries (1) in battery box (2) (para 7-57).</p> <p>g. Close battery box (TM 9-2320-360-10).</p> 	e. Cables are frayed or split.

Table 2-1. Preventive Maintenance Checks and Services (Cont)

ITEM NO.	INTERVAL	ITEM TO BE CHECKED OR SERVICED	PROCEDURE	NOT FULLY MISSION CAPABLE IF:
18	Semi-annually	WINCH AND WINCH HYDRAULICS	<p style="text-align: center;"><u>WARNING</u></p> <p>Be sure to wear the proper eye protection to avoid personal injury.</p> <ol style="list-style-type: none"> a. Check main winches (1) for leaks (para 2-11). b. Check auxiliary winch (2) for leaks. If leak is found, replace auxiliary winch (para 17-13). c. Tighten main winch mounting screws (3) to 600 lb-ft (814 N·m). d. Tighten auxiliary winch mounting screws (4) to 45 lb-ft (61 N·m). e. Remove winch control console panels (para 17-8). f. Check hoses (5) and control valves (6) for leaks, chafing, or cracks. If fault is found, notify supervisor. 	<ol style="list-style-type: none"> b. Any leak is found. f. Hoses leak or chafes or cracks are found.

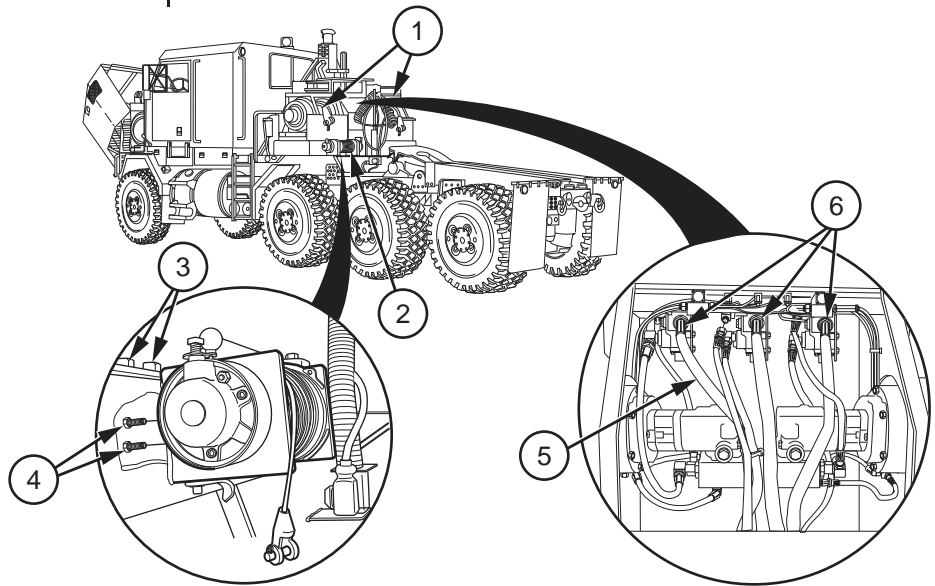


Table 2-1. Preventive Maintenance Checks and Services (Cont)

ITEM NO.	INTERVAL	ITEM TO BE CHECKED OR SERVICED	PROCEDURE	NOT FULLY MISSION CAPABLE IF:
<p>18 (cont)</p>	<p>Semi-annually</p>	<p>WINCH AND WINCH HYDRAULICS (CONT)</p>	<p>g. Check hydraulic reservoir (1) and hoses (2) for leaks, chafing, or cracks.</p> <p>h. Install winch control console panels (para 17-8).</p> <p>i. Perform all semiannual lubrication as identified in LO 9-2320-360-12.</p> <div data-bbox="386 758 1247 1213" data-label="Image"> </div> <p style="text-align: center;"><u>WARNING</u></p> <ul style="list-style-type: none"> • Wire rope can become frayed or contain broken wires. Wear heavy leather-palmed work gloves when handling wire rope. Frayed or broken wires can injure hands. • Never let moving wire rope slide through hands, even when wearing gloves. A broken wire may cut through glove and cut hand. <p>j. Individually unwind winch cables (1) completely and check for kinks, broken</p>	<p>g. Hoses leak or chafes or cracks are found.</p> <p>j. Winch cable has more than three</p>

Table 2-1. Preventive Maintenance Checks and Services (Cont)

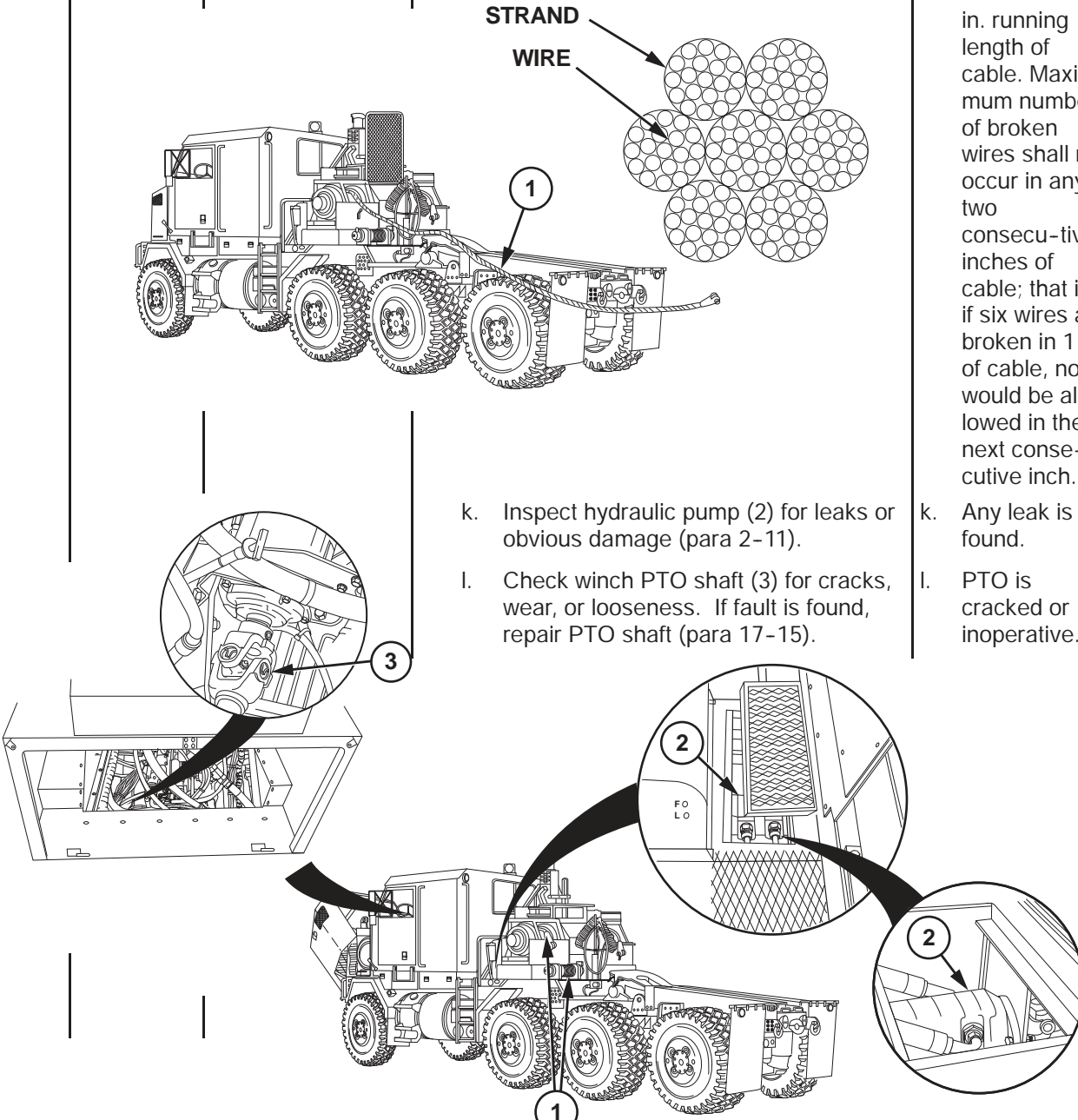
ITEM NO.	INTERVAL	ITEM TO BE CHECKED OR SERVICED	PROCEDURE	NOT FULLY MISSION CAPABLE IF:
18 (cont)	Semi-annually	WINCH AND WINCH HYDRAULICS (CONT)	<p>strands, and wear. If damaged or worn, replace cable (para 17-5/17-13).</p>  <p>k. Inspect hydraulic pump (2) for leaks or obvious damage (para 2-11).</p> <p>l. Check winch PTO shaft (3) for cracks, wear, or looseness. If fault is found, repair PTO shaft (para 17-15).</p>	<p>broken wires per inch on same strand or more than six broken wires on all strands in a 1 in. running length of cable. Maximum number of broken wires shall not occur in any two consecutive inches of cable; that is, if six wires are broken in 1 in. of cable, none would be allowed in the next consecutive inch.</p> <p>k. Any leak is found.</p> <p>l. PTO is cracked or inoperative.</p>

Table 2-1. Preventive Maintenance Checks and Services (Cont)

ITEM NO.	INTERVAL	ITEM TO BE CHECKED OR SERVICED	PROCEDURE	NOT FULLY MISSION CAPABLE IF:
19	Semi-annually	FIFTH WHEEL	a. Check fifth wheel (1) for gouges or loose or missing mounting hardware. b. Adjust fifth wheel (para 14-3).	a. Fifth wheel or mounting hardware is missing.
20	Semi-annually	AUXILIARY EQUIPMENT ARCTIC KIT BATTERIES (IF EQUIPPED)	a. Remove two rubber latches (1) from brackets (2). Remove battery box cover (3).	

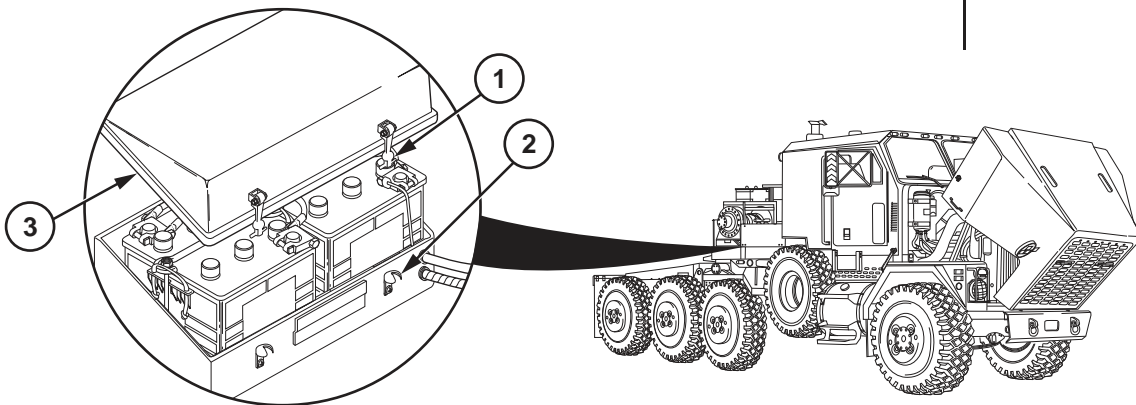
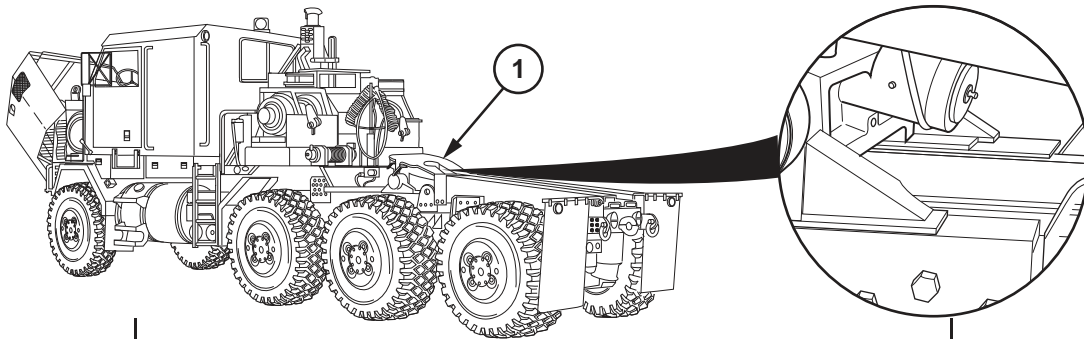


Table 2-1. Preventive Maintenance Checks and Services (Cont)

ITEM NO.	INTERVAL	ITEM TO BE CHECKED OR SERVICED	PROCEDURE	NOT FULLY MISSION CAPABLE IF:
20 (cont)	Semi-annually	ARCTIC KIT BATTERIES (IF EQUIPPED) (CONT)	<p>b. Remove batteries (1) from battery box (2) (para 19-3).</p> <p>c. Check battery box (2) for damage and debris. Clean battery box. If damaged, replace battery box (para 19-3).</p> <p>d. Check batteries (1) for damage. If damaged, replace battery (para 19-3).</p>	d. Battery cracked or missing.

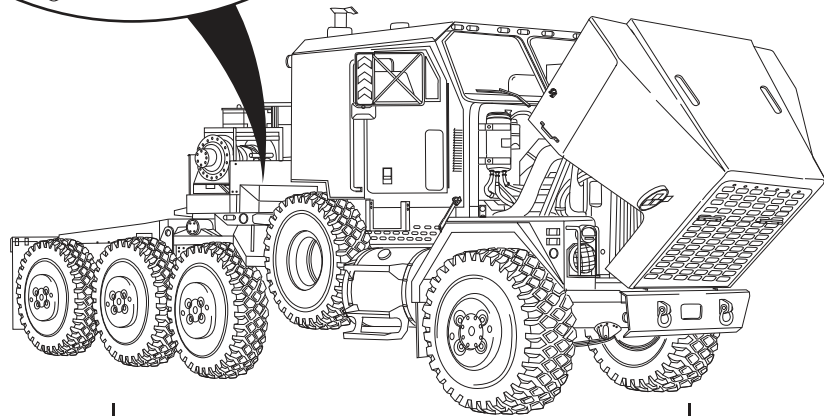
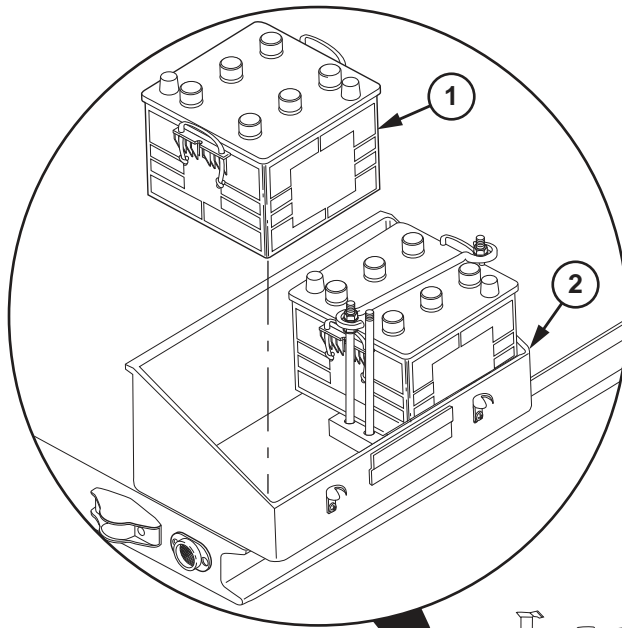


Table 2-1. Preventive Maintenance Checks and Services (Cont)

ITEM NO.	INTERVAL	ITEM TO BE CHECKED OR SERVICED	PROCEDURE	NOT FULLY MISSION CAPABLE IF:
20 (cont)	Semi-annually	ARCTIC KIT BATTERIES (IF EQUIPPED) (CONT)	<p style="text-align: center;">WARNING</p> <p>Remove rings, bracelets, watches, necklaces, and any other jewelry before working around HET Tractor. Jewelry can catch on equipment and cause injury or short across electrical circuit and cause severe burns or electrical shock. Batteries can explode from a spark. Battery acid is harmful to skin and eyes. Always wear eye protection when working with batteries.</p> <p style="text-align: center;">NOTE</p> <p>Make a separate test for each battery cell.</p> <p>e. Check and record specific gravity of each cell using antifreeze and battery tester (Item 49, Appendix F):</p> <ol style="list-style-type: none"> (1) Using black dipstick, place a few drops of electrolyte on exposed portion of measuring window. (2) Point tester toward a bright light source. <p style="text-align: center;">NOTE</p> <p>Full charge is 1.280 specific gravity.</p> <ol style="list-style-type: none"> (3) Record specific gravity of each cell. (4) Replace battery if specific gravity is below 1.225 (para 19-3). 	<p>e. Any battery has one cell below 1.225 specific gravity.</p>

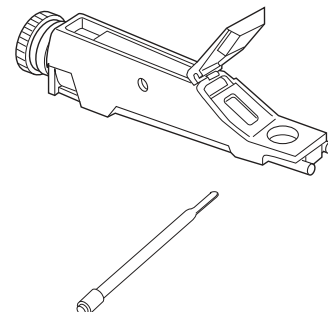
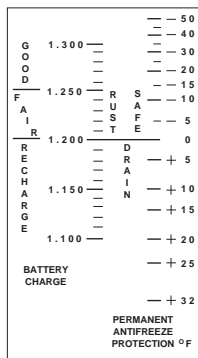


Table 2-1. Preventive Maintenance Checks and Services (Cont)

ITEM NO.	INTERVAL	ITEM TO BE CHECKED OR SERVICED	PROCEDURE	NOT FULLY MISSION CAPABLE IF:
20 (cont)	Semi-annually	ARCTIC KIT BATTERIES (IF EQUIPPED) (CONT)	<p>f. Check battery cables (1) for frays and splits. Check terminals (2) for looseness. Clean and grease battery connections. If damaged, replace battery cables and terminals (para 7-57).</p> <p>g. Install batteries (3) in battery box (4) (para 19-3).</p> <p>h. Install battery box cover (5). Install two rubber latches (6) in brackets (7).</p>	f. Cable frayed or split.

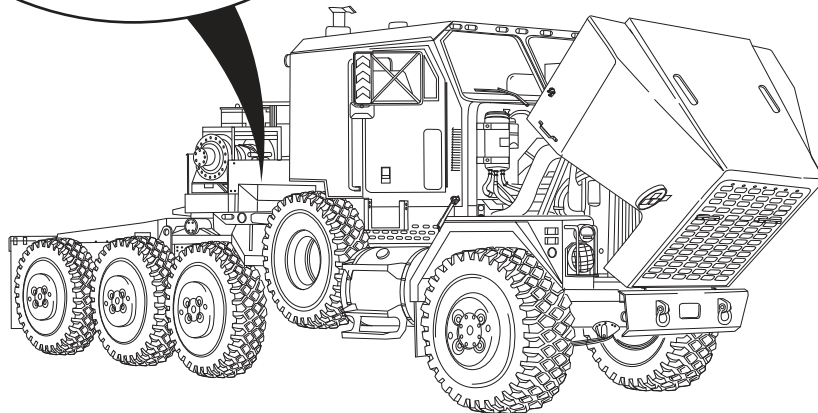
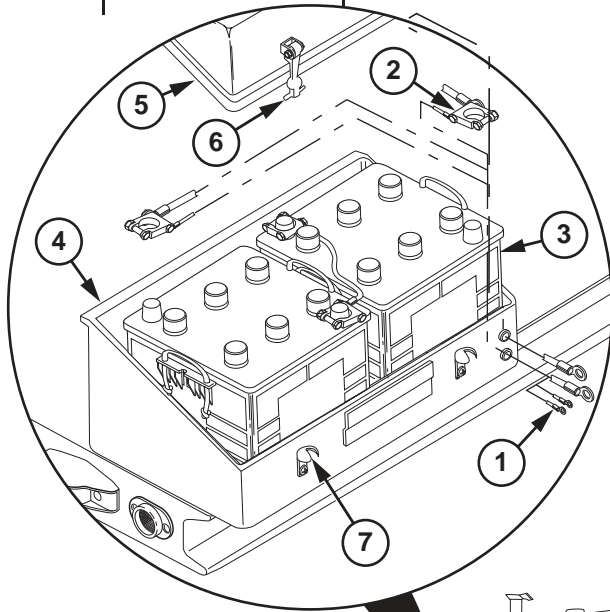


Table 2-1. Preventive Maintenance Checks and Services (Cont)

ITEM NO.	INTERVAL	ITEM TO BE CHECKED OR SERVICED	PROCEDURE	NOT FULLY MISSION CAPABLE IF:
21	Semi-annually	INSIDE DOGHOUSE AIR SYSTEM	Remove engine access panels (para 16-2). a. Build system air pressure to 120-125 psi (827-862 kPa) (TM 9-2320-360-10). b. Check air compressor (1) and hoses (2) for leaks, chafing, or cracks. Tighten loose connections. Replace damaged hoses (para 11-29).	b. Air leaks or presence of oil in air system is found.
22	Semi-annually	STEERING SYSTEM	Check steering pump (1) and hoses (2) for leaks and loose or missing mounting hardware.	Class III oil leaks are found.

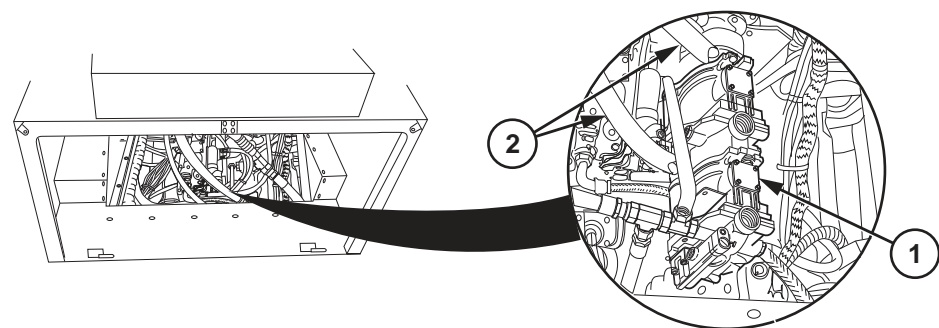
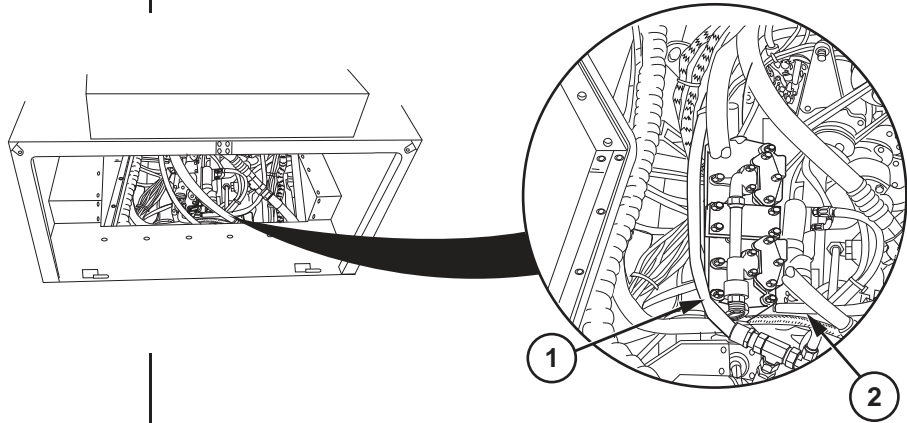


Table 2-1. Preventive Maintenance Checks and Services (Cont)

ITEM NO.	INTERVAL	ITEM TO BE CHECKED OR SERVICED	PROCEDURE	NOT FULLY MISSION CAPABLE IF:
23	Semi-annually	ENGINE	<p>Check 12-volt belts (1) for proper tension with belt tension gage (2). Belt tension gage reading should be 70-90 lb (310-400 N). If gage reading is not correct, adjust belts (para 7-6).</p>	Belts are burned, cracked, ripped, frayed, or cut.

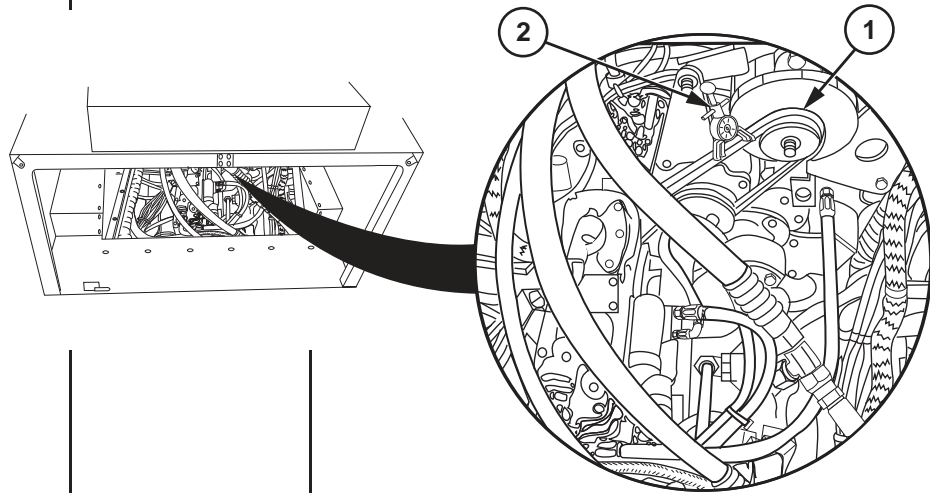


Table 2-1. Preventive Maintenance Checks and Services (Cont)

ITEM NO.	INTERVAL	ITEM TO BE CHECKED OR SERVICED	PROCEDURE	NOT FULLY MISSION CAPABLE IF:
24	Semi-annually	GAS PARTICULATE FILTER UNIT (GPFU)	<p style="text-align: center;">NOTE</p> <p>Replace precleaners and particulate filter if any of the following conditions exist: physical damage or water immersion, clogged filter resulting in insufficient air flow, or if the filters exceed criteria established in FM 3-4.</p> <ol style="list-style-type: none"> a. Inspect and replace, if required, precleaners and particulate filter in accordance with FM 3-4 and local climatic conditions. b. Check operation of GPFU (TM 9-2320-360-10). <ol style="list-style-type: none"> (1) Listen for gas particulate filter motor operation. (2) Disconnect five air duct breakaway sockets (1) from mounts (2) and feel for steady air flow. 	

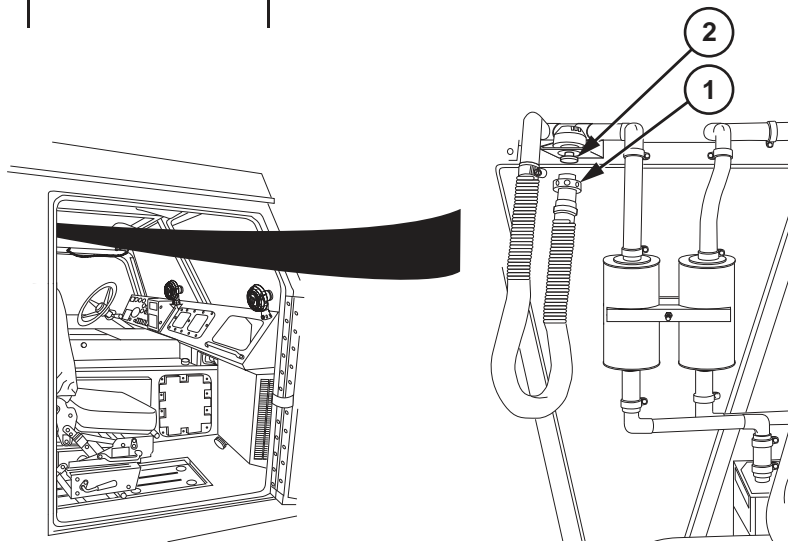


Table 2-1. Preventive Maintenance Checks and Services (Cont)

ITEM NO.	INTERVAL	ITEM TO BE CHECKED OR SERVICED	PROCEDURE	NOT FULLY MISSION CAPABLE IF:
25	Semi-annually	STEERING	<p style="text-align: center;">NOTE</p> <ul style="list-style-type: none"> HET Tractor must be driven a minimum of 10 miles (16 kilometers) during road test. Items 25 and 26 will be performed during road test. <p style="text-align: center;">NOTE</p> <p>Do not turn tires when turning wheel to check for free play.</p> <p>a. Turn steering wheel (1) to right until resistance is felt (A). Note location of one of the steering wheel spokes (2). Turn steering wheel (1) to left until resistance is felt (B). Measure distance the noted steering wheel spoke (2) has travelled. Free play is measured at outside edge of steering wheel and should not be more than 2-1/2 in. (6.4 cm).</p>	

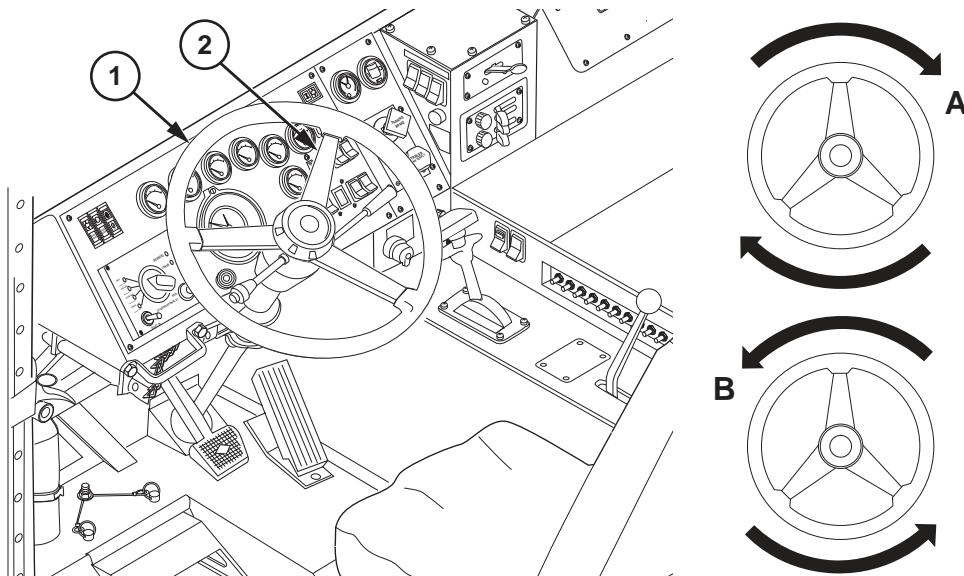


Table 2-1. Preventive Maintenance Checks and Services (Cont)

ITEM NO.	INTERVAL	ITEM TO BE CHECKED OR SERVICED	PROCEDURE	NOT FULLY MISSION CAPABLE IF:
25 (cont)	Semi-annually	STEERING (CONT)	<p>b. With HET Tractor on straight, level road, lightly hold steering wheel (1) to check for pull or wander.</p> <p style="text-align: center;">CAUTION</p> <p>Do not hold steering wheel at full right or left position for more than 10 seconds. Failure to comply may result in oil overheating and pump damage.</p> <p>c. With HET Tractor stopped, transmission in N (neutral), and parking brake applied, turn steering wheel (1) all the way right and then left to check for hard steering. If steering wheel does not operate properly, refer to troubleshooting (para 2-13).</p>	

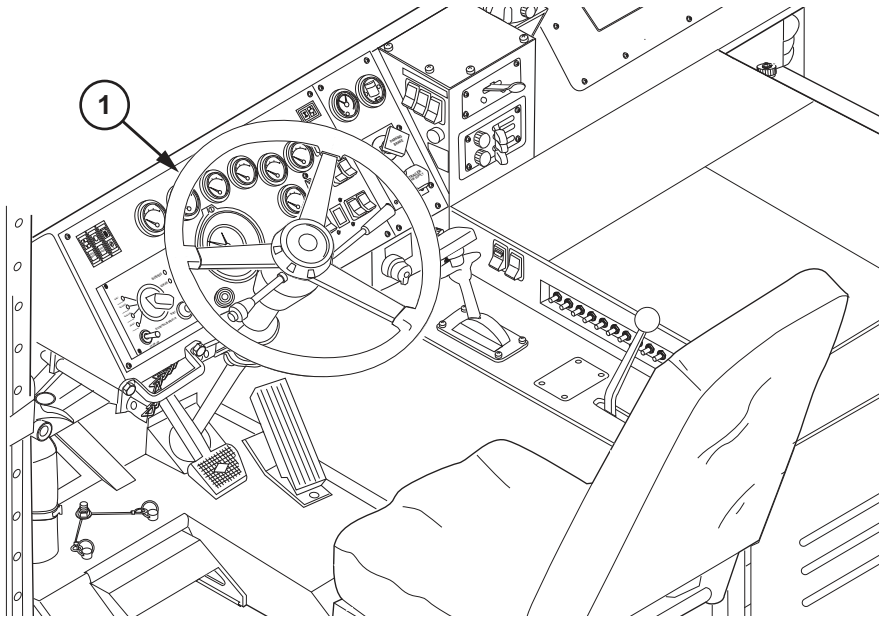


Table 2-1. Preventive Maintenance Checks and Services (Cont)

ITEM NO.	INTERVAL	ITEM TO BE CHECKED OR SERVICED	PROCEDURE	NOT FULLY MISSION CAPABLE IF:
26	Semi-annually	ENGINE	<p style="text-align: center;">CAUTION</p> <p>At full throttle, engine must not exceed 2225 rpm. Failure to comply may result in damage to equipment.</p> <ol style="list-style-type: none"> a. Press accelerator pedal (electronic throttle) (1) and check engine operation (TM 9-2320-360-10). If engine overspeeds (2225 rpm maximum), notify supervisor. b. Press engine brake retarder ON/OFF switch (2) to ON position. Press engine brake retarder HI/LO switch (3) to LO position. Fully press accelerator pedal (1), then release. There should be low engine braking. Press engine brake retarder HI/LO switch (3) to HI position. Fully press accelerator pedal, then release. There should be high engine braking. If engine brake retarder does not operate properly, refer to troubleshooting (para 2-13). 	<ol style="list-style-type: none"> a. Engine overspeeds. b. Engine overspeeds.

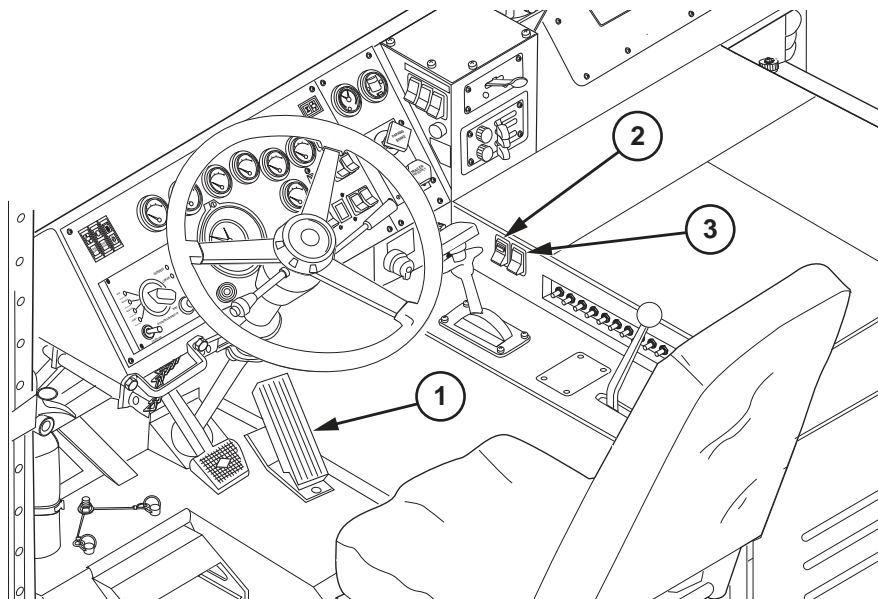


Table 2-1. Preventive Maintenance Checks and Services (Cont)

ITEM NO.	INTERVAL	ITEM TO BE CHECKED OR SERVICED	PROCEDURE	NOT FULLY MISSION CAPABLE IF:
26.1	Semi-annually	SEAT BELTS	<p style="text-align: center;"><u>WARNING</u></p> <ul style="list-style-type: none"> • Failure to properly inspect and maintain seat belts can cause serious injury or loss of life. • If the replacement of any part of the seat belt is required, the entire seat belt assembly must be replaced. <ol style="list-style-type: none"> a. Check for worn webbing (1) at the latch (2) and D-loop (3) areas. b. Check D-loop (3) for free rotation, deformation, cracks or damage. c. Check comfort latch (4) for proper operation, cracks and damage. 	<p>Webbing is cut, frayed, or excessively worn.</p> <p>D-loop does not rotate freely or is deformed, cracked or broken.</p> <p>Comfort latch is broken, or does not lock in place easily and does not release by tugging down on webbing.</p>

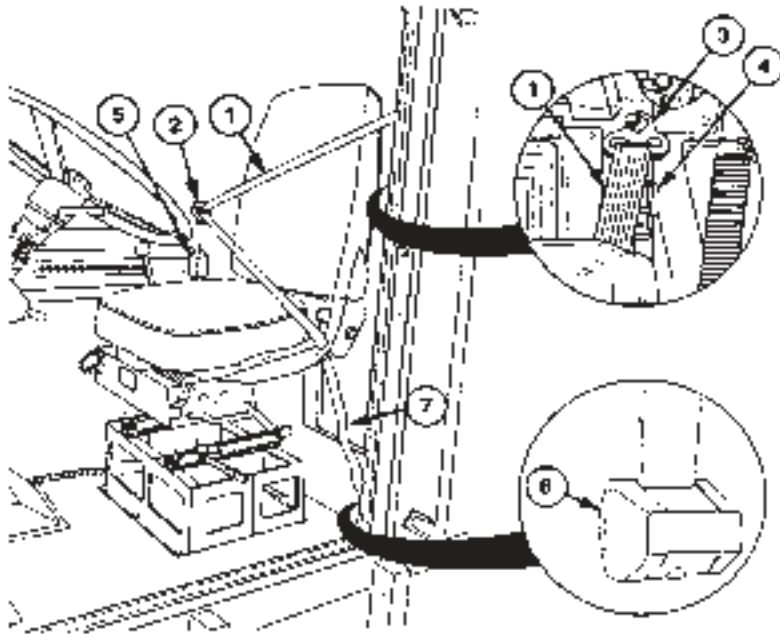


Table 2-1. Preventive Maintenance Checks and Services (Cont)

ITEM NO.	INTERVAL	ITEM TO BE CHECKED OR SERVICED	PROCEDURE	NOT FULLY MISSION CAPABLE IF:
26.1 (cont)	Semi-annually	SEAT BELTS (CONT)	<ul style="list-style-type: none"> d. Check latch (2) and buckle (5) for wear, deformation, damage or broken casing. e. Check latch (2) and buckle (5) for proper operation. f. Check that retractor (6) is not locked up and spools out/retracts webbing (1) properly. g. Check tethers (7) for proper attachment to seat. h. Check all seat belt mounting hardware for looseness and other damage. 	<p>Molded plastic around buckle/latch is deformed, cracked or broken.</p> <p>Buckle/latch does not engage with a solid sounding "click" and/or does not release freely when button is pushed.</p> <p>Retractor does not operate properly or retractor cover is cracked/broken.</p> <p>Tethers are loose or missing.</p> <p>Hardware is loose, missing, rusted, corroded or damaged.</p>

Table 2-1. Preventive Maintenance Checks and Services (Cont)

ITEM NO.	INTERVAL	ITEM TO BE CHECKED OR SERVICED	PROCEDURE	NOT FULLY MISSION CAPABLE IF:
27	Annually	EXTERIOR	<p>a. Check mud flap (1) for rips and loose or missing mounting hardware. If fault is found, refer to mud flap replacement (para 16-6).</p> <p>b. Check winch personnel guard (2) for cracks, bends, and loose or missing mounting hardware. If faults are found, refer to personnel guard replacement (para 17-8).</p>	
<p>The diagram shows a side view of a heavy-duty vehicle. A circular callout '1' points to a mud flap mounted on the front wheel. Another circular callout '2' points to a winch personnel guard located behind the engine compartment.</p>				
27.1	Annually	COOLING SYSTEM	<p style="text-align: center;">NOTE</p> <p>Fan clutch checks must be done when the engine coolant temperature is less than 195°F (91°C).</p> <p>a. Pull fan blade forward and then toward engine. There should be no forward or rearward movement of fan mounting hub (1). If fault is found, replace fan clutch (para 6-9).</p> <p>b. Push tip of a fan blade with light force clockwise, then counterclockwise. If rotational movement exceeds 1/2 in. (12.7 mm), replace fan clutch (para 6-9).</p>	

2-57 Table 2-1. Preventive Maintenance Checks and Services (Cont)

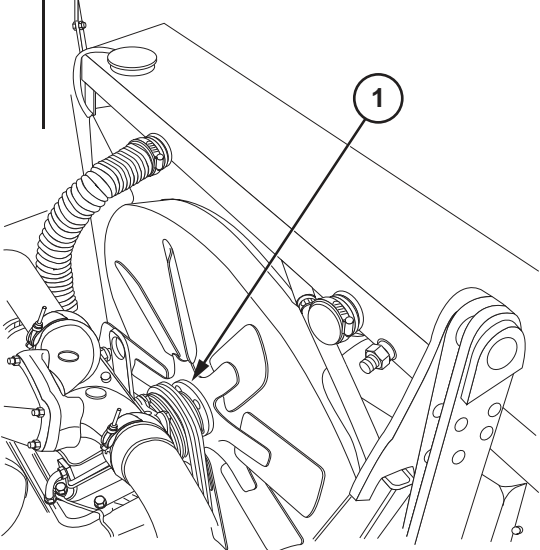
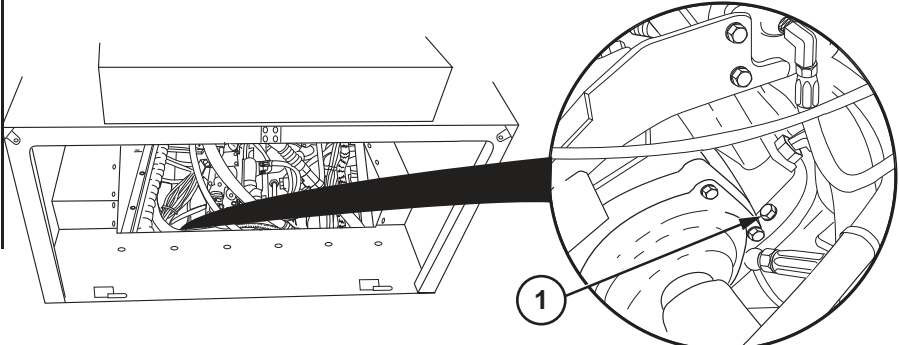
ITEM NO.	INTERVAL	ITEM TO BE CHECKED OR SERVICED	PROCEDURE	NOT FULLY MISSION CAPABLE IF:
27.1 (cont)	Annually	COOLING SYSTEM (CONT)		
28	Annually	TRANSMISSION	<p>a. Disconnect batteries (para 7-61).</p> <p>WARNING Remove rings, bracelets, watches, necklaces, and any other jewelry before working around HET Tractor. Jewelry can catch on equipment and cause injury or short across electrical circuit and cause severe burns or electrical shock. Batteries can explode from a spark. Battery acid is harmful to skin and eyes. Always wear eye protection when working with batteries.</p> <p>b. Check PTO (1) for loose mounting hardware, leakage, or cracks.</p>	b. Leaks are found.
				

Table 2-1. Preventive Maintenance Checks and Services (Cont)

ITEM NO.	INTERVAL	ITEM TO BE CHECKED OR SERVICED	PROCEDURE	NOT FULLY MISSION CAPABLE IF:
28 (cont)	Annually	TRANSMISSION (CONT)	<p>c. Service transmission breather:</p> <p style="text-align: center;">NOTE</p> <p>Transmission breather can be accessed by reaching under power steering pump, between air compressor and power steering pump.</p> <p>(1) Remove transmission breather (2) from reducer (3).</p> <p style="text-align: center;"><u>WARNING</u></p> <p>Solvent cleaning compound MIL-PRF 680 Type II and III may be irritating to the eyes and skin. Use protective gloves and goggles. Use in well-ventilated areas. Use respirator as needed. Accidental ingestion can cause irritation of digestive tract and respiratory tract, may cause lung and central nervous system damage. Can be fatal if swallowed. Inhalation of high/massive concentrations can cause coma or be fatal. First aid for ingestion: do not induce vomiting. Seek immediate medical attention. First aid for skin contact: remove contaminated clothing. Wash skin thoroughly with soap and water. If symptoms persist, seek medical attention. First aid for eye contact: flush with water for 15 minutes or until irritation subsides. If symptoms persist, seek medical attention. First aid for inhalation: move to fresh air. If not breathing, provide artificial respiration. If symptoms persist, seek medical attention. Keep away from open flames and other sources of ignition. Failure to follow this warning may result in injury or death to personnel.</p> <ul style="list-style-type: none"> •The flashpoint for type II solvent cleaning compound is 141-198°F (61-92C) and type III is 200-241°F (93-116C). •Improper cleaning methods and use of unauthorized cleaning solvents may injure personnel and damage equipment. •Fire extinguishers should be placed nearby when using solvent cleaning compound. Failure to follow this warning may result in injury or death. •Cloths or rags saturated with solvent cleaning compound must be disposed of IAW authorized facilities' procedures. Failure to follow this warning may result in injury. •Eye shields must be worn when cleaning with a wire brush. Flying rust and metal particles may cause injury. <p>(2) Clean transmission breather (2) with solvent cleaning compound.</p>	

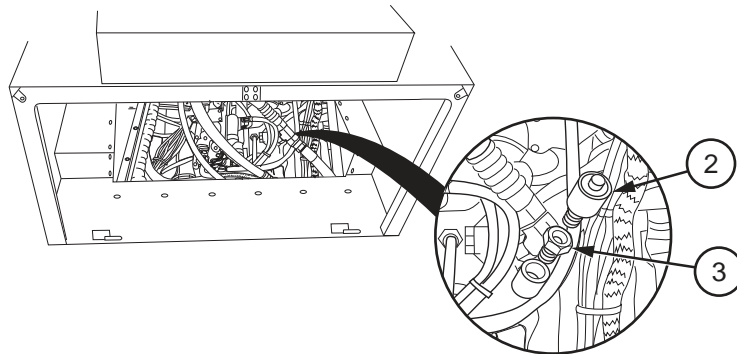


Table 2-1. Preventive Maintenance Checks and Services (Cont)

ITEM NO.	INTERVAL	ITEM TO BE CHECKED OR SERVICED	PROCEDURE	NOT FULLY MISSION CAPABLE IF:
28 (cont)	Annually	TRANSMISSION (CONT)	<p style="text-align: center;"><u>WARNING</u></p> <p>Compressed air for cleaning purposes will not exceed 30 psi (207 kPa). Use only with effective chip guarding and personal protective equipment (goggles/shield, gloves, etc.).</p> <ul style="list-style-type: none"> (3) Dry transmission breather (2) with compressed air. (4) Check inside transmission breather (2) for contamination. Ensure cap moves in and out freely. <p style="text-align: center;"><u>WARNING</u></p> <p>Pipe thread sealing compound may burn or give off harmful vapors. It is harmful to skin and clothing. To avoid injury or death, keep away from open flame and use in well-ventilated area. If pipe thread sealing compound gets on skin or clothing, wash immediately with soap and water.</p> <p style="text-align: center;"><u>CAUTION</u></p> <p>Use pipe thread sealing compound sparingly only on pipe threads. Do not apply compound to hose connections. Failure to comply may result in component failure.</p> <ul style="list-style-type: none"> (5) Coat threads of breather (2) with pipe thread sealing compound. (6) Install breather (2) in reducer (3). 	

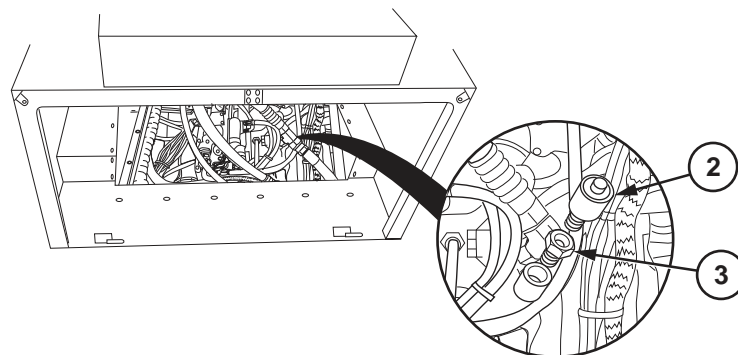


Table 2-1. Preventive Maintenance Checks and Services (Cont)

ITEM NO.	INTERVAL	ITEM TO BE CHECKED OR SERVICED	PROCEDURE	NOT FULLY MISSION CAPABLE IF:
29	Annually	TRANSFER CASE	<p>a. Service transfer case breather.</p> <p>(1) Remove transfer case breather (1) from elbow (2). Discard breather.</p> <p>WARNING Pipe thread sealing compound may burn or give off harmful vapors. It is harmful to skin and clothing. To avoid injury or death, keep away from open flame and use in well-ventilated area. If pipe thread sealing compound gets on skin or clothing, wash immediately with soap and water.</p> <p>CAUTION Use pipe thread sealing compound sparingly only on pipe threads. Do not apply compound to hose connections. Failure to comply may result in component failure.</p> <p>(2) Coat threads of new breather (1) with pipe thread sealing compound.</p> <p>(3) Install new breather (1) in elbow (2).</p>	

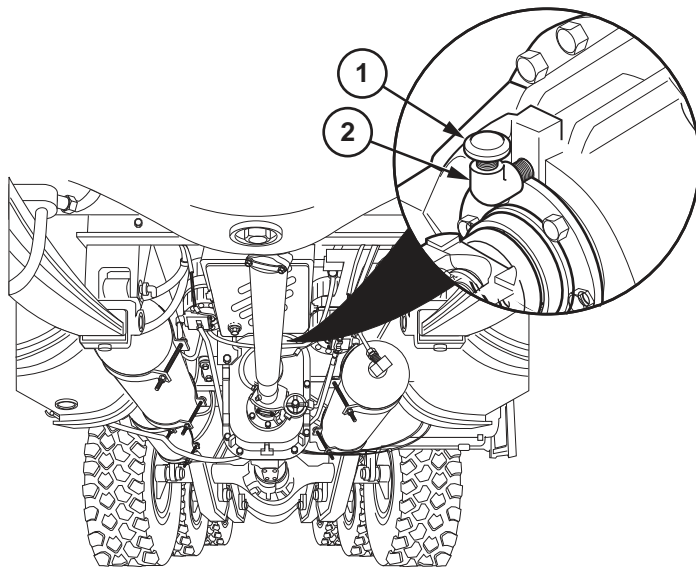


Table 2-1. Preventive Maintenance Checks and Services (Cont)

ITEM NO.	INTERVAL	ITEM TO BE CHECKED OR SERVICED	PROCEDURE	NOT FULLY MISSION CAPABLE IF:
30	Annually	AIR SYSTEM	<ul style="list-style-type: none"> a. Check air governor adjustment (para 11-30). If not correct, adjust air governor. b. Service both air dryers (para 11-32). c. Service aftercooler (para 11-34.3). d. Service coalescing filter (para 11-34.2). 	a. Air governor cannot be adjusted.
31	Annually	AUXILIARY EQUIPMENT ARCTIC KIT (IF EQUIPPED)	Check water jacket (1) and coolant pump (2) for cracks, leaks, and missing mounting hardware. If faults are found, refer to arctic kit water jacket replacement (para 19-9) or arctic kit coolant pump replacement (para 19-6).	Any leaks are found.

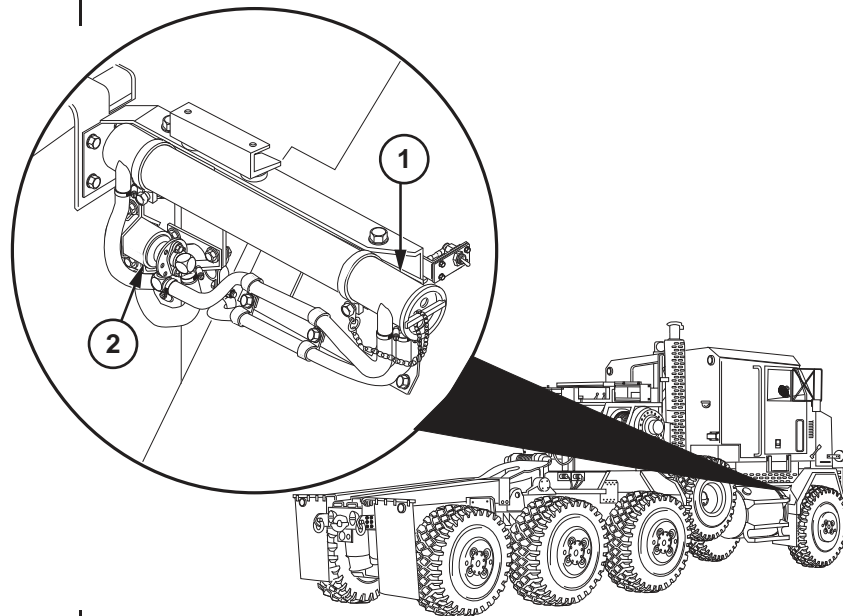


Table 2-1. Preventive Maintenance Checks and Services (Cont)

ITEM NO.	INTERVAL	ITEM TO BE CHECKED OR SERVICED	PROCEDURE	NOT FULLY MISSION CAPABLE IF:
32	Annually	STEERING	<p style="text-align: center;"><u>WARNING</u></p> <ul style="list-style-type: none"> • Auxiliary steering pump is driven by transfer case center shaft. To test operation of auxiliary steering pump, transfer case shafts must be turned by running the engine. Propeller shafts must be disconnected to prevent movement of HET Tractor. Failure to comply may result in injury to personnel. • Never disconnect any hydraulic hose while engine is running. Allow several minutes after engine is shut off for pressure to drop. Failure to comply may result in injury to personnel. <p style="text-align: center;">NOTE</p> <p>Propeller shafts only have to be disconnected from transfer case end. Leave propeller shafts attached at axle end.</p> <ol style="list-style-type: none"> a. Remove transfer case to axle no. 1 propeller shaft and transfer case to axle no. 2 propeller shaft from transfer case yokes (para 10-2). 	

Table 2-1. Preventive Maintenance Checks and Services (Cont)

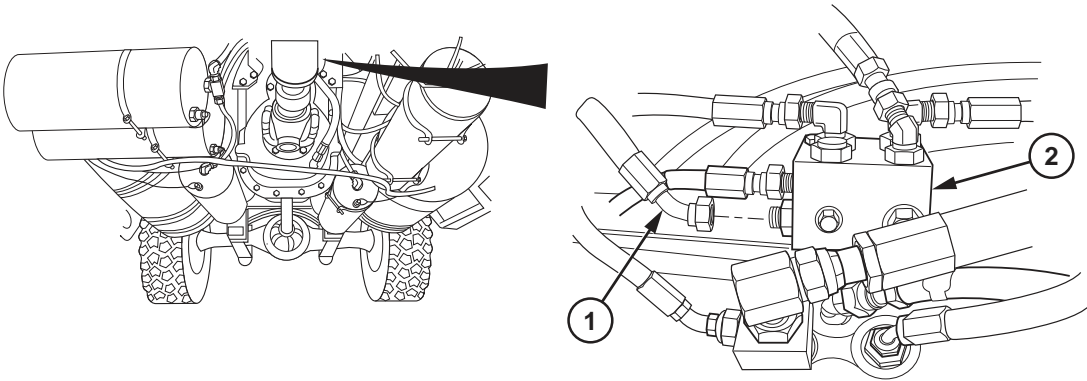
ITEM NO.	INTERVAL	ITEM TO BE CHECKED OR SERVICED	PROCEDURE	NOT FULLY MISSION CAPABLE IF:
32 (cont)	Annually	STEERING (CONT)	<p>b. Remove hose no. 2879 (1) from auxiliary steering pump manifold (2).</p> <p style="text-align: center;">NOTE</p> <p>Fluid will drip from fitting during test. Do not cap manifold fitting. Auxiliary steering will be intermittent if fitting is capped.</p> <p>c. Install plug (Item 28.1, Appendix F) in hose no. 2879 (1).</p> <p>d. Position drain pan under auxiliary steering pump manifold (2).</p>	
			<p style="text-align: center;">WARNING</p> <p>Keep out from under vehicle during test. Transfer case output yokes will rotate during test. Failure to comply may result in injury to personnel.</p> <p>e. Place transfer case shift lever in HIGH range (TM 9-2320-360-10).</p> <p>f. Start engine (TM 9-2320-360-10).</p> <p>g. Place transmission range selector in 2-5 position (TM 9-2320-360-10).</p>	

Table 2-1. Preventive Maintenance Checks and Services (Cont)

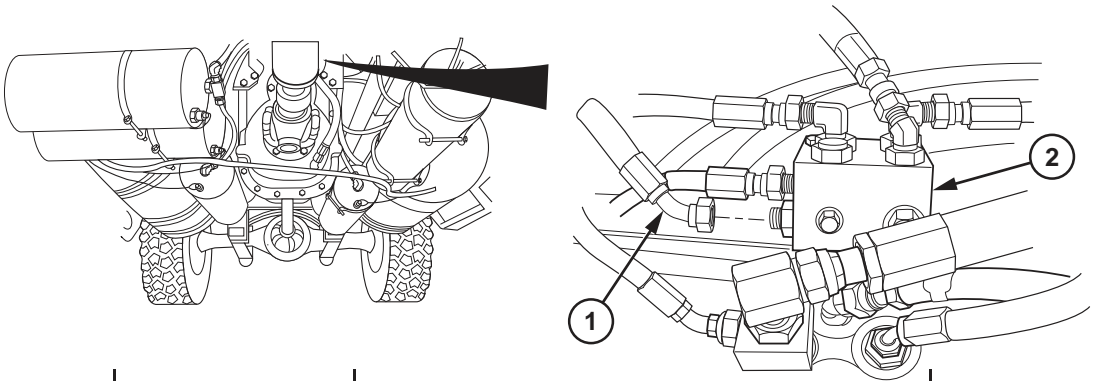
ITEM NO.	INTERVAL	ITEM TO BE CHECKED OR SERVICED	PROCEDURE	NOT FULLY MISSION CAPABLE IF:
32 (cont)	Annually	STEERING (CONT)	<p style="text-align: center;">NOTE</p> <p>Transmission must shift from 2nd to 3rd gear before accurate test results can be obtained.</p> <p>h. Increase engine speed until tachograph indicates approximately 20 mph.</p> <p style="text-align: center;">NOTE</p> <p>If steering wheel cannot be turned, refer to direct support maintenance for troubleshooting.</p> <p>i. Turn steering wheel several times from full right to full left position.</p> <p>j. Shut off engine (TM 9-2320-360-10).</p> <p>k. Remove plug from hose no. 2879 (1).</p> <p>l. Install hose no. 2879 (1) on steering pump manifold (2).</p> <p>m. Install transfer case to axle no. 1 propeller shaft and transfer case to axle no. 2 propeller shaft (para 10-2).</p>	i. Steering wheel cannot be turned during test.
				

Table 2-1. Preventive Maintenance Checks and Services (Cont)

ITEM NO.	INTERVAL	ITEM TO BE CHECKED OR SERVICED	PROCEDURE	NOT FULLY MISSION CAPABLE IF:
32 (cont)	Annually	STEERING (CONT)	<p>n. Check steering stops on no. 1 and no. 4 axles.</p> <p>(1) Apply parking brake (TM 9-2320-360-10).</p> <p>(2) Chock wheels.</p> <p>(3) Start engine (TM 9-2320-360-10).</p> <div data-bbox="418 821 1243 1220" style="text-align: center;"> <p>The diagram shows a side view of a truck with a callout circle focusing on the steering mechanism. In the callout, a steering stop is labeled '1' and the axle housing is labeled '2'. An arrow points from the callout to the front of the truck.</p> </div> <p>WARNING Keep out from under vehicle when assistant turns steering wheel. Failure to comply may result in injury to personnel.</p> <p>(4) Turn steering wheel to full right position.</p> <p>(5) Inspect for 1/16-1/8 in. (1.6-3.2 mm) clearance between steering stop (1) and axle housing (2).</p> <p>(6) Turn steering wheel to full left position and repeat inspection of left steering stop.</p> <p>(7) Shut off engine (TM 9-2320-360-10).</p>	n. Steering stop to axle housing clearance is not 1/16-1/8 in. (1.6-3.2 mm). Contact direct support maintenance for steering stop adjustment.

Section IV. TROUBLESHOOTING

2-13. INTRODUCTION TO LOGIC TREE TROUBLESHOOTING

a. Page Layout The troubleshooting is divided into symptoms peculiar to a vehicle system or component (for example, air system or fifth wheel). This manual cannot list all malfunctions that may occur, nor all tests, inspections, or corrective actions. If a malfunction is not listed or is not corrected by listed corrective actions, notify supervisor.

First, determine the symptom or condition that indicates a problem or failure. Refer to Table 2-5. Engine Electronic Controls (DDEC) Troubleshooting or Table 2-7. Vehicle Troubleshooting following this introduction arranged by major vehicle system.

Go to the referenced page to begin troubleshooting. Open the manual flat so that both the right and left hand pages are displayed before you. The information on all facing pages is important.

All diagnostic logic and flowcharts are on the left hand page, with supporting information, warnings, cautions, notes, and test instructions on the right. (See figure on next page.) Pages are set up so you do not need any more than the necessary information, notes, warnings and cautions about a particular question. The experienced technician can generally read just left hand pages and refer to information on the right page when needed. All critical information for decisions is on the left page. Do the tests and inspections in the order listed, and try to return the vehicle or component to operation after each test, inspection, and corrective action has been performed.

b. How To Begin Troubleshooting

- (1) Identify the symptom or fault. Select the applicable symptom (grouped by systems). Follow Vehicle Troubleshooting BEFORE going to DDEC Troubleshooting.
- (2) Follow the diagnostic procedure. Answer question no 1. on the left hand page and follow the YES or NO path to either the remedy or the next question. Helpful information about the problem is also on the left page. Look on the right page for additional specific instructions and help.
- (3) Observe warnings, cautions, and notes. **WARNING** is the symbol for a warning statement. If you see this block above a question on the left page, look on the right page for the text of the message. The **WARNING** message on the right page will also have the symbol above it. **CAUTION** is the symbol for a caution statement. If you see this block above a question on the left page, look on the right hand page for the text of the message. The **CAUTION** message on the right hand page will also have the symbol above it. Examples:

WARNING

The ENGINE switch should always be OFF before the harness connectors are disconnected or reconnected. Failure to comply may result in electrical shock.

CAUTION

When disconnecting harness connectors, apply pulling force to the connectors themselves and not the wires extending from them. Failure to comply will damage wire.

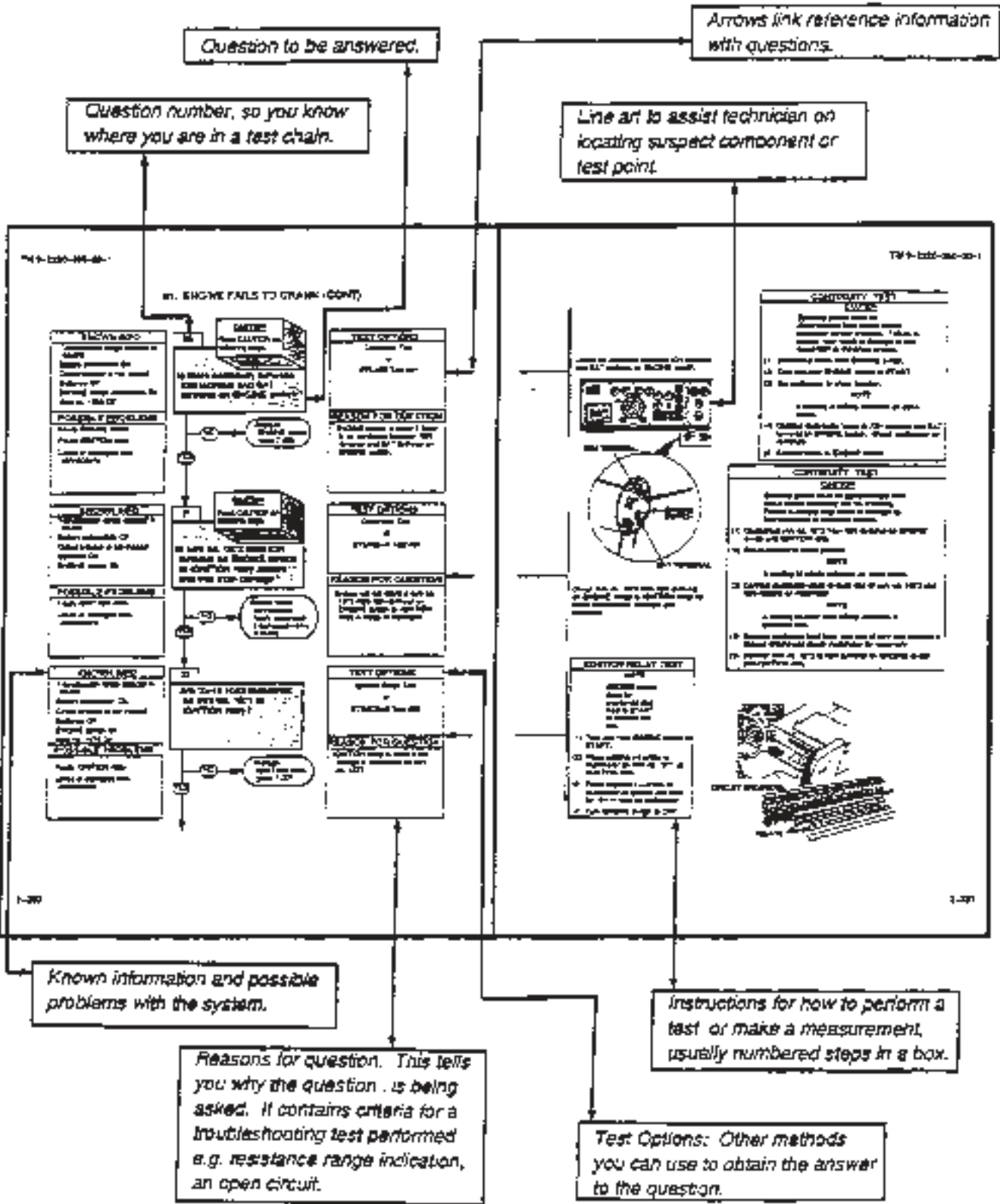
NOTE

After harness connectors are reconnected to the DDEC system, the computer diagnostics should be ignored and cleared.

c. Measurements Required for Troubleshooting

- (1) Resistance Measurements
 - (a) Connect the red test lead to the volt-ohm input connector and black lead to the Common (COM) input connector on the meter.

2-13. INTRODUCTION TO LOGIC TREE TROUBLESHOOTING (CONT)



- (b) Set the function/range switch to the desired ohm position. If the magnitude of the resistance is not known, set the switch to the highest range, then reduce until a satisfactory reading is obtained.
- (c) If the resistance being measured is connected to a circuit, turn ENGINE switch OFF.
- (d) Connect test leads to the circuit being measured. When measuring high resistance, be careful not to contact adjacent points, even if they are insulated. Some insulators have a relatively low insulation resistance which can affect the resulting measurement.
- (e) Read the resistance value on the digital display.

(2) Continuity Checks

- (a) Place the function/range switch in any ohm range.

NOTE

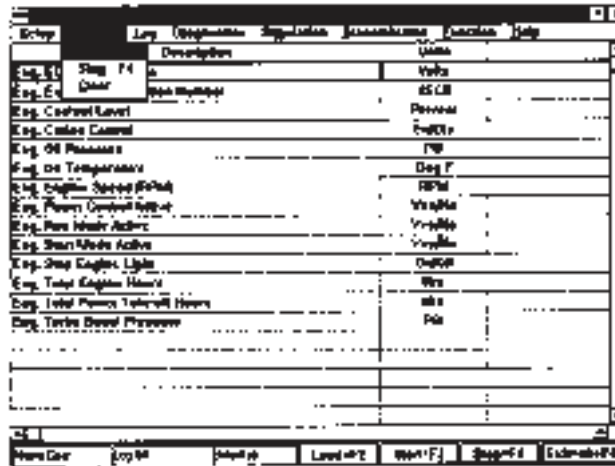
Some meters show '1+m', or simply '1' when function/range switch in any ohm position.

- (b) Connect the red lead to the volt-ohm connector and black lead to COM input connector on the meter. With the test leads separated or measuring an out-of-range resistance, the digital display will indicate 'OL' (overlimit).
- (c) Put one test lead probe at one end of the wire or circuit to be tested. Use the other test lead to trace the circuit. When continuity is established, an ohm symbol will appear in the upper left corner of the digital display. If contact in the wire is maintained long enough (about 1/4 of a second), the OL will disappear and the resistance value of the wire or circuit will appear next to the symbol.

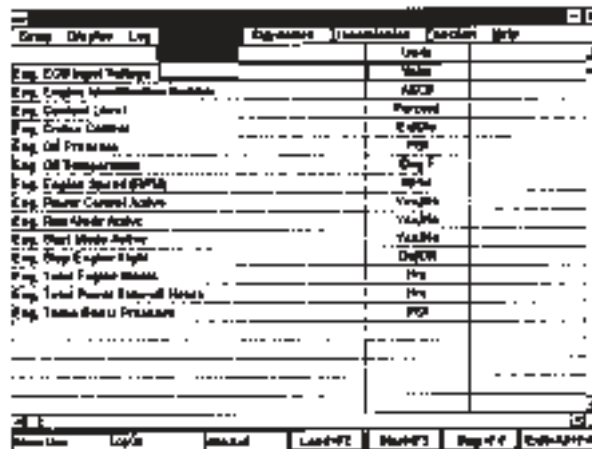
(3) Voltage Measurements

- (a) Connect the red test lead to the volt-ohm input connector and the black lead to the COM input on the meter. If a DC-AC switch is present, make sure it is switched to the DC position.
- (b) Set the function/range switch to the desired volts position. If the magnitude of the voltage is not known, set the switch to highest DC voltage range (50VDC). Then reduce the range until a satisfactory reading is obtained.
- (c) Connect the test leads to the circuit being measured. Voltage measurements are always taken at pins, sockets, Battery + or ground. Following the voltage measurement point, the color test lead used is given in parenthesis (red is volt-ohm connection, and black is the COM connection).

2-13. INTRODUCTION TO LOGIC TREE TROUBLESHOOTING (CONT)



- (b) Display Menu Commands. The commands in this section allow the operator to control the data that is being displayed.
 1. Start. The start command allows the user to start the display data after it has been stopped for viewing. The command only affects the data which is being displayed.
 2. Stop. The Stop command allows the user to stop the constantly changing display data. This allows the operator to freeze the display and study the data.
 3. Clear. The Clear command allows the operator to clear the data values from the various readouts. New data will be displayed as it becomes available.
- (c) Log Menu Commands. The commands in this section allow the operator to control the various log functions. The operator may play back a previously recorded log, or may create a new log to store incoming data. This function is not used in the HET M1070 troubleshooting.



- (d) Diagnostics Menu Commands. The commands in this section allow the operator to view the alarms (active codes) and work the status diagnostics.
 1. Alarms (Active Codes). The Alarms command allows the operator to view all the systems alarms (active codes). When this command is selected, the Current Alarms window is displayed. This window will display all alarms (active codes) that have been detected since system start up or the last time this window was cleared. From this window, the operator can also set the alarm priority for both the Pop-up Window and the Beep Alarm.
 2. Status. Not applicable.

- (e) Simulation Menu Commands. The commands in this section allow the J1708 unit to be used as a training simulator. This application is not used during troubleshooting of the HET M1070.
- (f) Transmission Menu Commands. The commands in this section allow the operator to select the modes for ATEC Transmission Data. This application is not used on the HET M1070 Tractor.

Menu	Description	Unit	Function
Eng. ECU Status	ECU Status	Yes	Function 0 and Time-Out
Eng. ECU Identification Number	ECU ID	Yes	GROUP 40 Display
Eng. Control Level	Control Level	Percent	
Eng. Control Control	Control Control	Control	
Eng. 4th Pressure	4th Pressure	Pa	
Eng. 4th Temperature	4th Temperature	Temp	
Eng. 4th Speed (RPM)	4th Speed	RPM	
Eng. Power Control Active	Power Control Active	Variable	
Eng. Power Mode Active	Power Mode Active	Variable	
Eng. Power Mode Active	Power Mode Active	Variable	
Eng. Power Mode Active	Power Mode Active	Variable	
Eng. Total Engine Hours	Total Engine Hours	hrs	
Eng. Total Power Take-Off Hours	Total Power Take-Off Hours	hrs	
Eng. Total Start Pressure	Total Start Pressure	PSI	

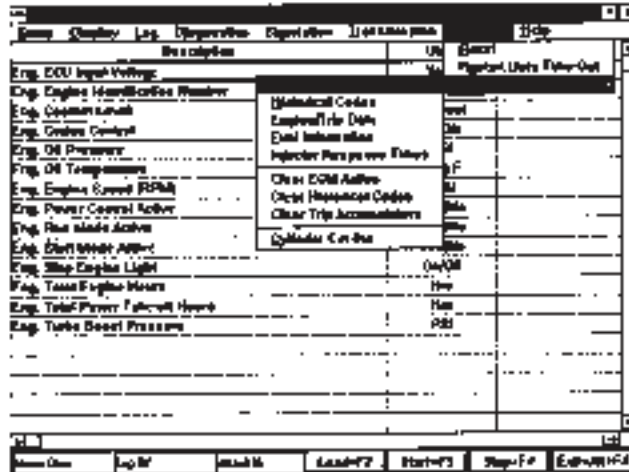
- (g) Function Menu Commands. The commands in this section allow the operator to reset the J1708 computer board and to choose various DDEC options.
 1. Reset. The Reset command is used to reset the J1708 board. When this command is used, all board functions will be reset to zero (0) and the Electronic Control Module (ECM) will run through a self test.
 2. Restart Data Time-out. This selection is used to re-start the time-out test sequence for the presence of J1708 data when the "No J1708 Input Data" message is displayed.
 3. DDEC-II Option Commands. Refer to paragraph (4) for details.

2-13. INTRODUCTION TO LOGIC TREE TROUBLESHOOTING (CONT)

Name	Display	Log	Description	Variables	Transmission	Error/Dev
Eng. ECU Input Voltage				Volt		Engine/ECU
Eng. Engine Identification Number				ASCII		Engine/ECU
Eng. Coolant Level				Percent		Water/Water
Eng. Coolant Control				Enable		Water/Water
Eng. Oil Pressure				PSI		
Eng. Oil Temperature				Temp F		
Eng. Engine Speed (RPM)				RPM		
Eng. Power Control Solenoid				Variable		
Eng. Power Mode Active				Variable		
Eng. Water Inlet Active				Variable		
Eng. Eng. Engine Light				Variable		
Eng. 3-4 Shift Engage Status				Yes		
Eng. 4-5 Shift Engage Status				Yes		
Eng. 5-6 Shift Engage Status				Yes		

- (h) Help Menu Commands. The commands in this section allow the user to access the on-line help topics.
 1. Contents. This section lists the Help items that are available to the operator from this program. These items may be selected directly from this list or from the Help Menu Commands window.
 2. Commands. This section allows the operator to access descriptions of the commands found in this program. When the operator selects one of the menu selections listed below, the screen will display descriptions for the commands found under that menu. For instructions on how to use the commands, the operator should go back to the Main Help Menu and select "PROCEDURES".
 3. Procedures. This menu allows the user to select the procedures to perform various tasks within the J1708 User Interface program.
 4. Using Help. If you are new to Help, choose Help Basics. Use the scroll bar to view information not visible in the Help window. Click on the underlined topic you want to view, or press tab to select a topic, and then press ENTER.
 5. About. Information about the J1708 application, such as copyright, version, and application name; the mode Windows is running in; and the amount of memory available on your computer.

2-13. INTRODUCTION TO LOGIC TREE TROUBLESHOOTING (CONT)



- (4) DDEC-II Option Menu. Click on "OK" to return to the main window from the DDEC-II Options Menu.
 - (a) Engine ID/Calibration. Click on "Engine ID/Calibration". A pop up window will be displayed with the following information:
 1. Engine ID (Identification).
 2. ECM S/N (Electronic Control Module Serial Number).
 3. No. of Cyl (Number of Cylinders).
 4. EPA Cert. No. (EPA Certification Number).
 5. SW Level (ECM Software Version).
 6. Box Type (indicates whether ECM supports 6 or 8 cylinders).
 7. Pk Trq (Peak Torque in lb-ft).
 8. Spd Pk Trq (RPM at which peak torque is obtained).
 9. Option Word Window (status of options).
 10. Shutdown Word Window (status of shutdown words).
 - (b) View Historical Codes. Click on "Historical Codes". If historical codes are present, they will be displayed in a pop up window. The only codes displayed are those stored by the ECM since the last time the historical codes were cleared. If no codes are stored in the ECM, "No Historical Codes" will be displayed in the pop up window.
 - (c) Engine/Trip Data. Click on "Engine/Trip Data". A pop up window will be displayed with the following information:
 1. Fuel GPH (estimated fuel consumption rate in gallons per hour).
 2. Total GAL (estimated total fuel used in gallons).
 3. Eng Hours (total hours of engine operation).
 4. PTO Hours (total hours of PTO operation).
 5. Instant MPG (estimated instantaneous miles per gallon).
 6. Ave MPG (estimated average miles per gallon).
 7. Trip Miles (total distance since reset).

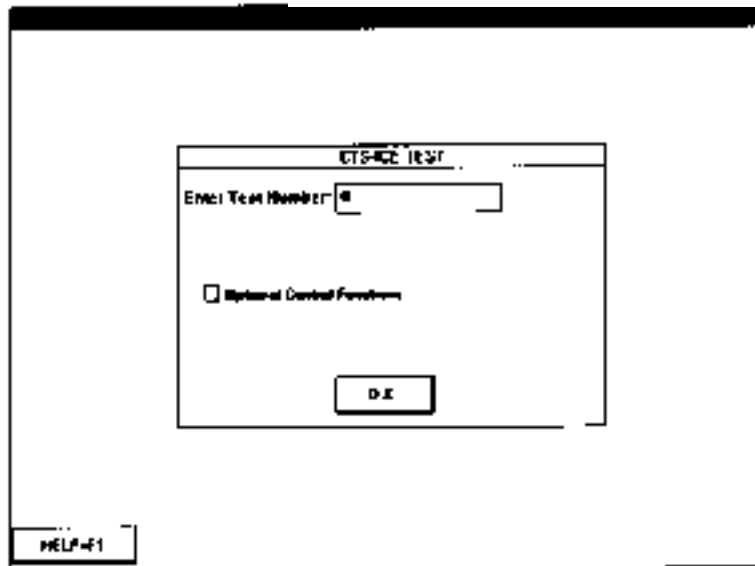
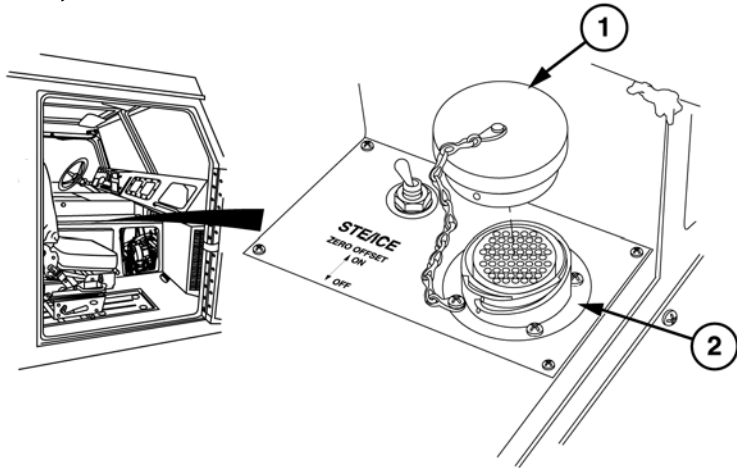
8. Trip GAL (estimated total fuel used since reset).
- (d) Fuel Information. Not applicable.
 - (e) Injector Response Times. Click on "Injector Response Times". The DDEC Injector Response Time Window will be displayed.
 - (f) Clear ECM Actions. Click on "Clear ECM Action". A pop up window will be displayed verifying the step. Click on "OK" to clear all ECM actions, click on "CANCEL" to return to the main window.
 - (g) Clear Historical Codes. Click on "Clear Historical Codes". A pop up window will be displayed verifying the step. Click on "OK" to erase all historical codes, click on "CANCEL" to return to the main window.
 - (h) Clear Trip Accumulators. Not applicable.
 - (i) Cylinder Cutout Function.
 - 1. Click on "Cylinder Cutout".
 - 2. Click on "Auto" or "1000 RPM". If "AUTO" is selected, the ECM will automatically cutout one cylinder at a time and the test results will be displayed as they occur. If "MANUAL" is selected, the operator must select the individual cylinder to be cutout.
 - 3. Click on "Idle" or "1000 RPM".
 - 4. Click on "Start", "Stop" or "Cancel". Selecting "Start" will change display to "Re-Start", and function will run until either "Stop" or "Cancel" is selected. If "Stop" is selected, the function will stop and "Re-Start" will change back to "Start". If "Cancel" is selected, the function will stop and the operator will be returned to the main menu.

2-13. INTRODUCTION TO LOGIC TREE TROUBLESHOOTING (CONT)

d.1. Contact Test Set (CTS), CTS-ICE Application, Introduction

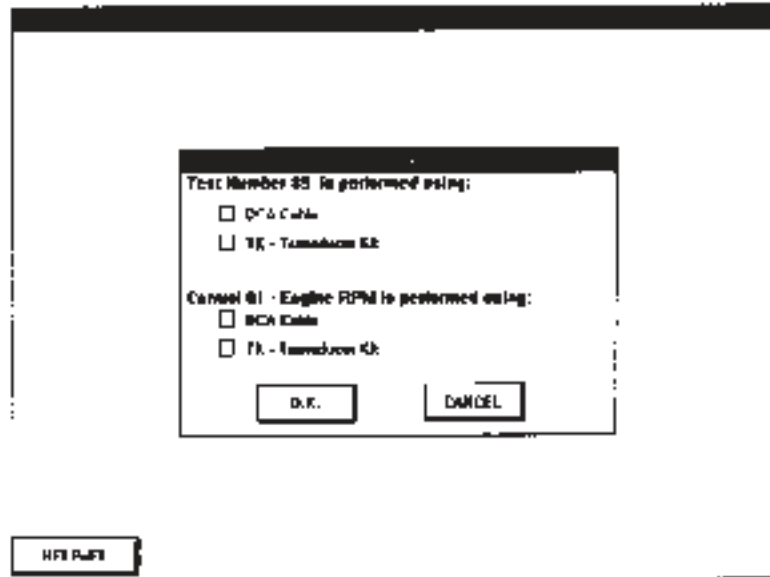
(1) Connecting CTS to HET M1070

- (a) Remove cover (1) from diagnostic connector assembly (DCA) (2) by turning counterclockwise.
- (b) Install DCA cable on DCA (2).
- (c) Prepare CTS for operation (TM - X-XXXX-XXX-XX).



(2) CTS-ICE Menu

- (a) Enter Test Number. Allows the user to enter the desired STE/ICE-R test number. CTS-ICE will display a message if any invalid test numbers are selected.
- (b) Optional Control Functions. CTS-ICE has the capability to perform two STE/ICE-R tests during a single session. For example, if a voltage reading is desired at a specific engine RPM, both STE/ICE-R test #10 (Engine RPM) and test #89 (voltage) can be conducted at the same time. To activate this function, click on the Optional Control Function Box. A message will be displayed if invalid test combinations are selected.
- (c) Click on "O.K." to proceed.



- (d) CTS-ICE Test Cable Set-up. Some STE/ICE-R tests can be conducted using either the DCA connector or external leads and transducers. This screen tells the CTS-ICE unit where to look for the test information. Click on "DCA Cable" for all tests except STE/ICE-R tests #45-51, #89 and #91. For these tests, select "TK - Transducer Kit".
 - (e) Click on "O.K." to proceed with the CTS-ICE test(s).
 - (f) Diagnostics. The selected CTS-ICE test(s) will be performed with detailed procedures specific to those tests selected. Follow instructions given by the CTS-ICE program.
- (3) On-Line Help. Click on "HELP=F1" or press "F1" to access the on-line help portion of the CTS-ICE program. Provides a quick way to find information, such as how to perform a particular task. Highlighted tasks indicate a topic with additional information. This additional information can be viewed by clicking on the highlighted area.
 - (a) Using Help. Information on how to use CTS-ICE help.
 - (b) CTS-ICE System Table Of Contents. An alphabetical list of all CTS-ICE help topics available.
 - (c) Alphabetical List of CTS-ICE Tests.
 - (d) Numerical List of CTS-ICE Tests.

2-13. INTRODUCTION TO LOGIC TREE TROUBLESHOOTING (CONT)

e. Abbreviations And Commonly Used Terms

- (1) A/D - Analog to Digital: The computer inside the ECM uses an A/D converter to convert a sensor voltage into a number with which the computer can work.
- (2) Active Codes - These are the codes that currently keep the CHECK ENGINE indicator on. They are read using the Diagnostic Data Reader.
- (3) BAT - Battery
- (4) CEL - CHECK ENGINE indicator: mounted on the instrument dash and used as panel. It has two functions:
 - (a) a warning lamp to tell the driver that a problem has occurred, and that the vehicle should be taken in for service as soon as possible.
 - (b) as a light bulb check and system check the CHECK ENGINE indicator will come on for about five seconds when the ENGINE switch is turned ON. If the CEL remains on, the self-diagnostic system has detected a problem. If the problem goes away, the light will go out, but the (HISTORICAL) trouble code will be stored in the ECM. (See General Diagnostic Information)
- (5) CKT - Circuit
- (6) CLS - Coolant Level Sensor: Monitors coolant level at the radiator tank top.
- (7) COM - Common
- (8) CTS - CONTACT TEST SET: Tool used for troubleshooting DDEC and for STE/ICE-R tests.
- (9) DCA - Diagnostic Connector Assembly: An electrical harness on the vehicle which allows the STE/ICE-R to be powered and to make measurements of key vehicle signals from a single connection. In addition to many basic electrical signals such as starter voltage and current, it includes engine speed and fuel supply pressure. The STE/ICE-R can make TK measurements at the same time that it is connected to the DCA.
- (10) DDEC - Second generation Engine Electronic Controls
- (11) DDL - Diagnostic Data Link: The lines (wires) over which the ECM communicates information to be read by a Diagnostic Data Reader.
- (12) Diagnostics: Troubleshooting by following an exact procedure.
- (13) DL+ - Data Link, positive side. Used for communications to the Diagnostic Data Reader, as well as other applications.
- (14) DL - Data Link, negative side (See above).
- (15) DREQ - Diagnostic Request Terminal: The pin on the DDL connector which must be grounded to obtain diagnostic codes (pin M).
- (16) ECM - Electronic Control Module: The brains of DDEC. It reads the DDEC sensors and switches, calculates injector firing times and duration (using a built-in computer), and fires the injectors at the appropriate times.
- (17) EEPROM - Electronically Erasable Programmable Read Only Memory. Contains the engine calibration.
- (18) EFPA - Electronic Foot Pedal Assembly: contains the Throttle Positions Sensor
- (19) Erratic: intermittent
- (20) EUI - Electronic Unit Injector: replaces the Mechanical Unit Injector (MUI)

- (21) Historical Codes – All codes kept in ECM memory (may not turn the CHECK ENGINE indicator). These codes can be cleared by using the Diagnostic Data Reader.
- (22) OPS – Oil Pressure Sensor: monitors oil pressure at the main oil gallery.
- (23) OTS – Oil Temperature Sensor: monitors oil temperature in the turbo oil supply line.
- (24) PCB – Protective Control Box: Located on the firewall above the brake pedal.
- (25) PW – Pulsewidth: the amount of time in crank degrees that the ECM is requesting the injectors to be turned on.
- (26) SEL – CHECK GAUGES Indicator: mounted on the dash, it lights to warn the driver when a potential engine damaging condition has been detected (low oil pressure, low coolant, or engine over temperature). As a light bulb check and system check, the CHECK GAUGES indicator will come on for about five seconds when ignition takes place.
- (27) SRS – Synchronous Reference Sensor: detects when the first cylinder in the firing order is about to be fired.
- (28) STE/ICE-R – Simplified Test Equipment for Internal Combustion Engines –Reprogrammable: A testing system used for performing tests and measurements on the vehicle. In addition to acting as a conventional digital multimeter to measure voltage, current and resistance, it is also capable of measuring pressure, speed, compression unbalance, engine power, and some specialized battery and starter evaluations. It is powered from the vehicle batteries. The complete system includes a vehicle test meter (VTM), a transducer kit (TK), cables, transit case, and technical publications. STE/ICE tests are referenced.
- (29) System: A collection of devices which are all related to each other because they depend on each other to do some function or job. For example, the function of the fuel system is to inject fuel into the cylinders at the correct time in the correct quantity. The collection of devices that are required to do this include the fuel pump, fuel lines, lift pump, fuel filter, injection pump, and injectors.
- (30) TBS – Turbo Boost Sensor: used to monitor turbo boost pressure. The sensor generates a voltage (from 0 to 5 volts) which is proportional to pressure.
- (31) Test Chain: A series of tests to be followed in a particular order or sequence(numbered).
- (32) TPS –Throttle Position Sensor: used to detect throttle request.
- (33) Troubleshooting: The process of making measurements and observing the operation of the vehicle to find out if and where any problems exist.
- (34) TRS – Timing Reference Sensor: detects whenever any cylinder is about to be fired.
- (35) VIN – Vehicle Identification Number
- (36) VTM – Vehicle Test Meter: A box which performs the measurement and analysis functions of the STE/ICE-R systems.

2-13. INTRODUCTION TO LOGIC TREE TROUBLESHOOTING (CONT)

Table 2-5. DDEC Troubleshooting

KEY SYMPTOM		
A. CHECK ENGINE indicator comes on and stays on.		
SECONDARY SYMPTOMS	PAGE	
A1 CHECK ENGINE indicator on and code 25 on DDR	2-94	
A2 CHECK ENGINE indicator always on, no data link, codes not flashing.	2-98	
A3 DDR display blank or random.	2-102	
A4 DDR reads active code other than code 25, and does not read any historic codes.		
Flash Codes:	SAE Codes:	
Code 11	P187 4 Vernier Control Signal Voltage Low	2-106
Code 12	P187 3 Vernier Control Signal Voltage High	2-116
Code 13	P111 4 Coolant Level Sensor (CLS) Signal Voltage Low	2-122
Code 14	P175 3 Oil Temperature Sensor (OTS) Signal Voltage High	2-126
Code 15	P175 4 Oil Temperature Sensor (OTS) Signal Voltage Low	2-130
Code 16	P111 3 Two Piece Coolant Level Sensor (CLS) Signal Voltage High	2-134
Code 21	P091 3 Throttle Position Sensor (TPS) Signal Voltage High	2-142
Code 22	P091 4 Throttle Position Sensor (TPS) Signal Voltage Low	2-148
Code 23	P174 3 Fuel Temperature Sensor (FTS) Signal Voltage High	2-158
Code 24	P174 4 Fuel Temperature Sensor (FTS) Signal Voltage Low	2-162
Code 31	Fault on Auxiliary Output	2-166
Code 32	ECM Backup System Failure	2-172
Code 33	P102 3 Turbo Boost Sensor (TBS) Signal Voltage High	2-174
Code 34	P102 4 Turbo Boost Sensor (TBS) Signal Voltage Low	2-180
Code 35	P100 3 Oil Pressure Sensor (OPS) Signal Voltage High	2-188
Code 36	P100 4 Oil Pressure Sensor (OPS) Signal Voltage Low	2-194
Code 41	S021 0 Timing Reference Sensor (TRS)	2-204
Code 42	S021 1 Synchronous Reference Sensor (SRS)	2-216
Code 43	P111 1 Low Coolant Level	2-228
Code 44	P175 0 High Oil Temperature	2-234
Code 45	P100 0 Low Oil Pressure	2-236
Code 46	P168 1 Low Battery Voltage	2-238
Code 51	Check Engine Light Comes On and Stays On	2-244
Code 52	S254 12 ECM - Analog to Digital Failure	2-246
Code 53	S253 12 EEPROM Failure Affecting Code Memory	2-248
Code 56	ECM - Analog to Digital Failure	2-250
Codes 61-68	Sxxx 0 Injector Response Times Too Long	2-252
Codes 71-78	Sxxx 1 Injector Response Times Too Short	2-264
Code 85	P190 0 Engine Overspeed	2-265.1
A4A	Check Vehicle Harness +5 Volt Supply	2-266
A4B	Check Engine Harness +5 Volt Supply	2-274

Table 205. DDEC Troubleshooting (Cont)

<u>KEY SYMPTOM</u>	
B. CHECK ENGINE indicator is out	
<u>SECONDARY SYMPTOMS</u>	<u>PAGE</u>
<u>B. CHECK ENGINE light is off when ENGINE switch is turned ON.</u>	<u>2-282</u>

<u>KEY SYMPTOM</u>	
C. CHECK ENGINE indicator comes on for up to five seconds after ENGINE switch is turned to ON, then goes out	
<u>SECONDARY SYMPTOMS</u>	<u>PAGE</u>
<u>C1 Engine cranks but will not start.</u>	<u>2-292</u>
<u>C2 No DATA link and bulb check OK</u>	<u>2-314</u>

<u>KEY SYMPTOM</u>	
D. CHECK ENGINE indicator is erratic or intermittent	
<u>SECONDARY SYMPTOMS</u>	<u>PAGE</u>
<u>D1 CHECK ENGINE indicator flashing valid code.</u>	<u>2-324</u>
<u>D2 DDR displays intermittent code.</u>	<u>2-326</u>
<u>D3 CHECK GAUGES indicator always on and Code 25 on DDR</u>	<u>2-330</u>
<u>D4 CHECK GAUGES indicator does not light when ENGINE switch is turned ON.</u>	<u>2-334</u>
<u>D5 Power take-off high idle does not operate.</u>	<u>2-340</u>
<u>D6 Engine brake always enabled.</u>	<u>2-348</u>
<u>D7 Engine brake does not operate.</u>	<u>2-352</u>

2-13. INTRODUCTION TO LOGIC TREE TROUBLESHOOTING (CONT)

NOTE

Chart is used only when a DDEC problem is suspected but no codes are displayed on DDR or codes are intermittent.

Table 2-6. DDEC Troubleshooting (No Codes on DDR)

<u>KEY SYMPTOM</u> No codes on DDR	
<u>SECONDARY SYMPTOMS</u>	<u>PAGE</u>
<u>CHECK ENGINE indicator on and code 25 on DDR</u>	2-94
<u>CHECK ENGINE indicator always on, no data link, codes not flashing.</u>	2-98
<u>CHECK ENGINE indicator does not light when ENGINE switch is positioned to ON.</u>	2-282
<u>Engine cranks but will not start.</u>	2-292
<u>No DATA link and bulb check OK</u>	2-314
<u>DDR displays intermittent code.</u>	2-326
<u>CHECK GAUGES indicator always on and code 25 on DDR.</u>	2-330
<u>No CHECK GAUGES indicator during bulb check</u>	2-334
<u>Power take off high idle not working.</u>	2-340
<u>Engine brake is always on.</u>	2-348
<u>Engine brake not working.</u>	2-354

f. Contact Test Set (CTS)

The troubleshooting for the HET M1070 Tractor was developed utilizing the Digital Data Reader (DDR) and Simplified Test Equipment for Internal Combustion Engines (STE/ICE-R). Since the initial publication of this manual, the Contact Test Set (CTS) has been developed for use as the primary Test, Measurement, and Diagnostic Equipment (TMDE) for the HET M1070, in place of the DDR and STE/ICE-R.

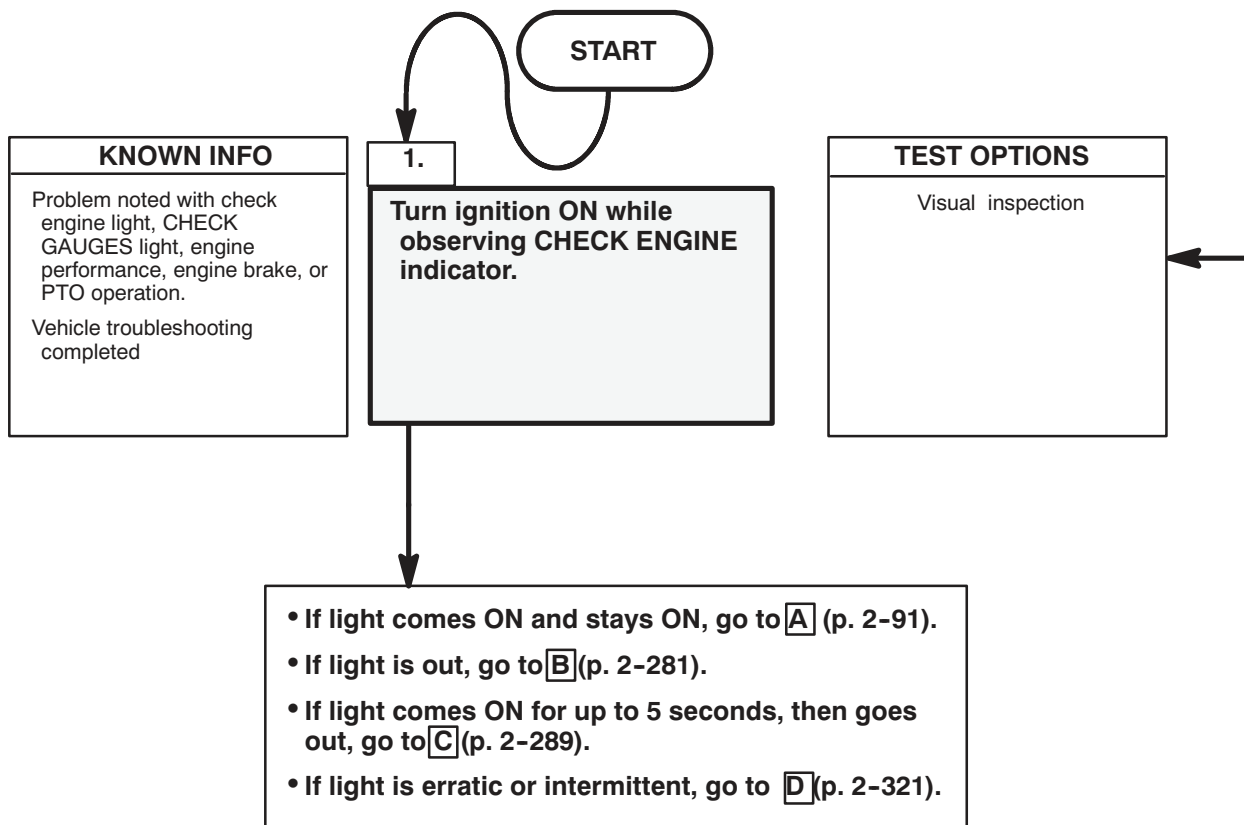
The CTS J1708 programming performs the same function as the DDR and the CTS/ICE programming performs the same tests as the STE/ICE-R unit. The procedural steps contained within this manual still reflect the original test equipment, however, the CTS can be used to troubleshoot the vehicle. The same test results will be obtained using either piece of test equipment.

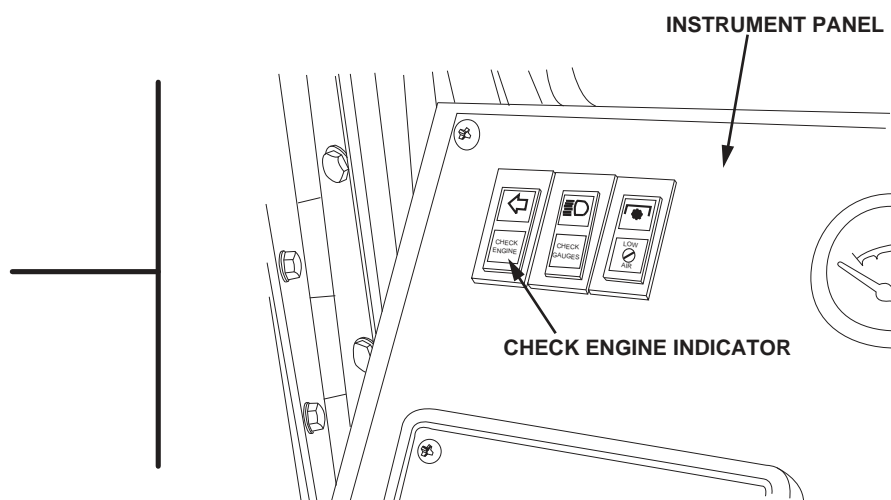
Some of the detailed test procedures shown on the right-hand pages of the troubleshooting will deviate slightly from the steps required to operate the CTS. For additional information on CTS operating procedures and individual test instructions, refer to the information provided with the CTS unit.

DDEC II TROUBLESHOOTING

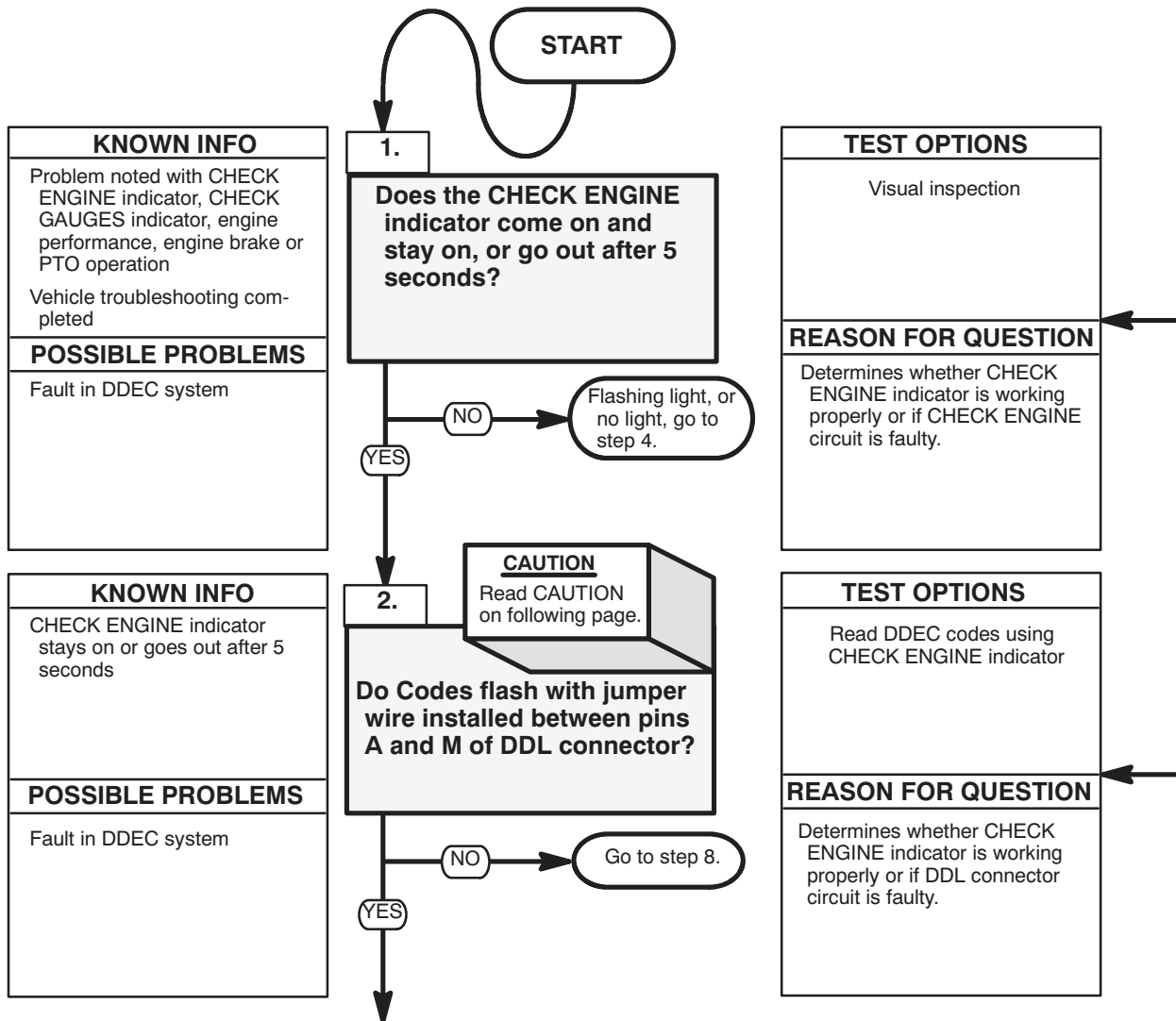
**TRUCK, TRACTOR, M1070
HEAVY EQUIPMENT TRANSPORTER (HET)**

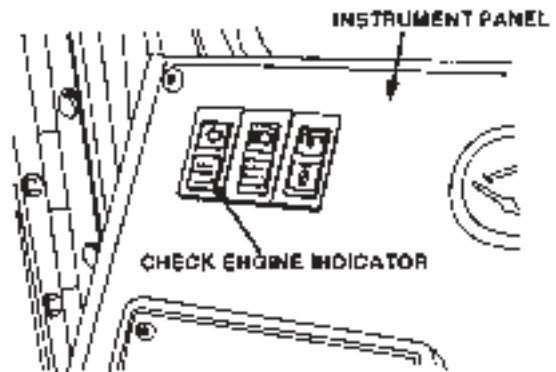
FIRST CHART FOR DIAGNOSIS OF DDEC USING DIAGNOSTIC DATA READER (DDR)	
INITIAL SETUP	
Equipment Conditions Engine shut off (TM 9-2320-360-10). Parking brake on (TM 9-2320-360-10). Wheels chocked.	Tools and Special Tools Tool Kit, Genl Mech (Item 54, Appendix F) Contact Test Set, (Item 3.1, Appendix F) Jumper Wire (Figure D-20, Appendix D) TRS/SRS Alignment Tool, (Item 55, Appendix F) Multimeter (Item 20, Appendix F)





FIRST CHART FOR DIAGNOSIS OF DDEC WHEN NO DIAGNOSTIC DATA READER (DDR) IS AVAILABLE	
INITIAL SETUP	
Equipment Conditions Engine shut off (TM 9-2320-360-10). Parking brake on (TM 9-2320-360-10). Wheels chocked.	Tools and Special Tools Tool Kit, Genl Mech (Item 54, Appendix F) Jumper Wire (Figure D-20, Appendix D) Multimeter (Item 20, Appendix F)

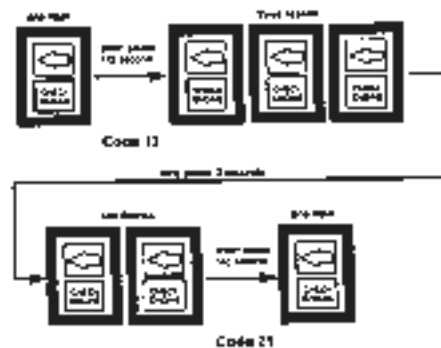




NOTE

DDEC Troubleshooting was intended to be used with a Diagnostic Data Reader. Should you need to read out codes, however, and a reader is not available, the following steps will allow you to read codes using the CHECK ENGINE indicator. However, later sections of the DDEC Troubleshooting may require the use of a reader.

- (4) Turn engine switch to ON position (TM 9-2320-360-10).
- (5) Note operation of CHECK ENGINE indicator.
- (6) Turn engine switch to OFF position (TM 9-2320-360-10).



Example:

READ DDEC CODES USING CHECK ENGINE INDICATOR

- (1) Remove eight screws and cover from electronic control box assembly.

CAUTION

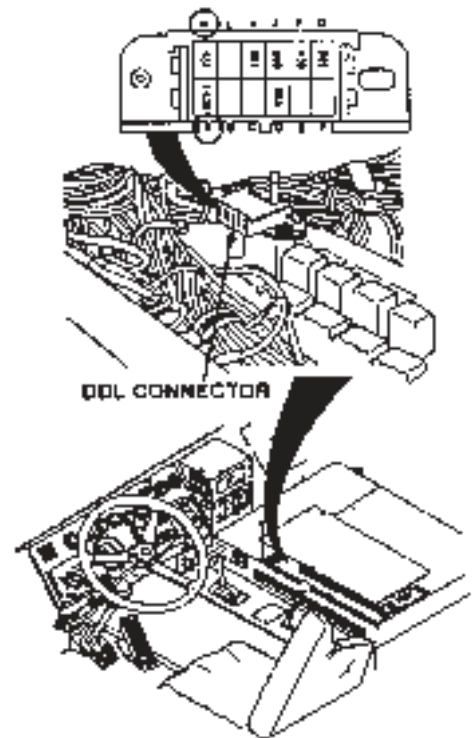
Use jumper wire only between terminals indicated. Failure to comply may result in damage to DDEC components or wiring.

- (2) Install suitable wire (paper clip) between pins A and M of the 12 pin, DDL connector.
- (3) Turn ENGINE SWITCH to ON position (TM 9-2320-360-10).

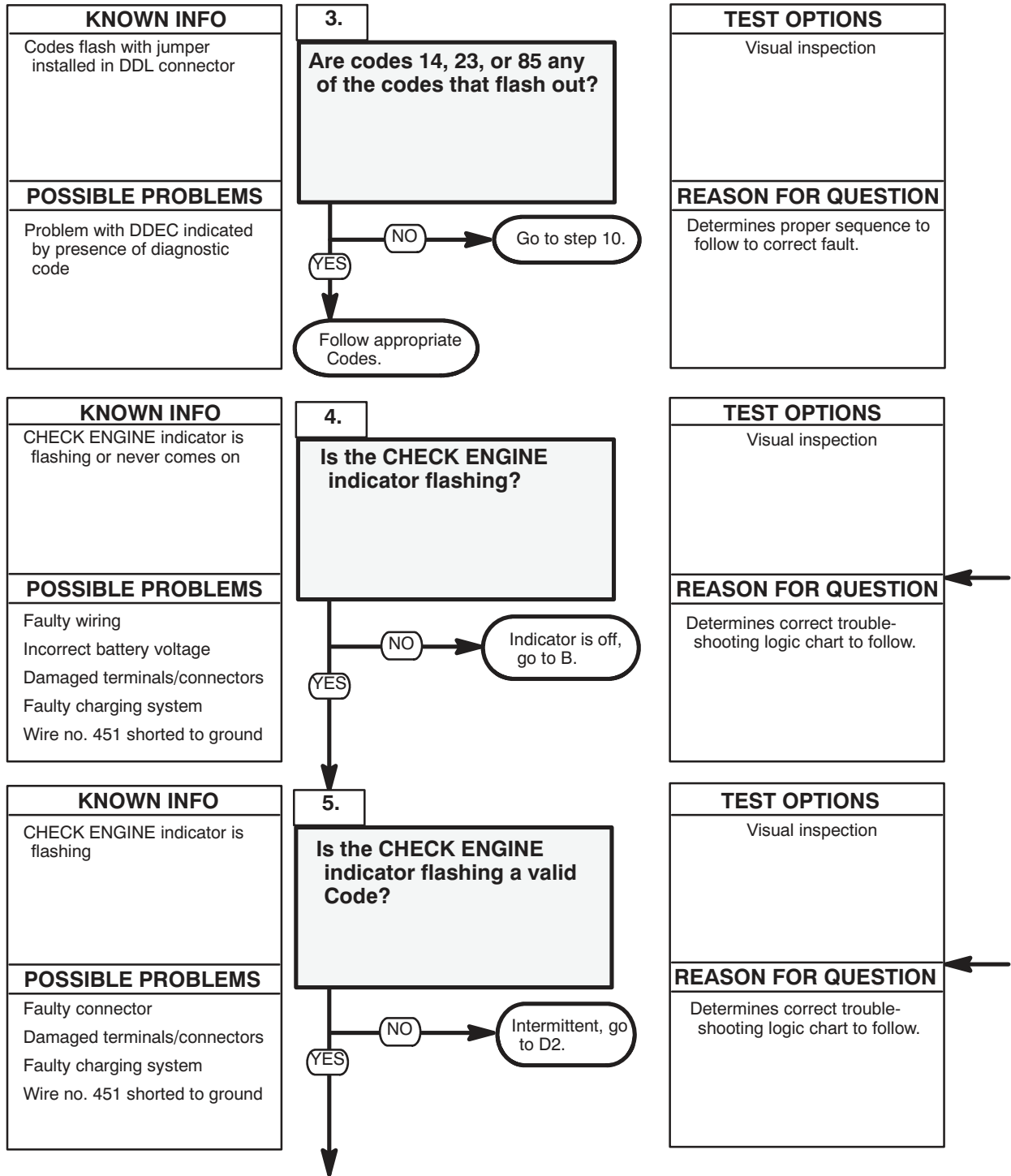
NOTE

- Indicator will flash the first digit of code, followed by a short 1/2 second pause, then the second digit. There will be a long three second pause between codes.
- Indicator will flash all codes in Historic memory, before repeating all codes.
- Indicator will continue to flash as long as pins are jumped and ENGINE switch is in the ON position.

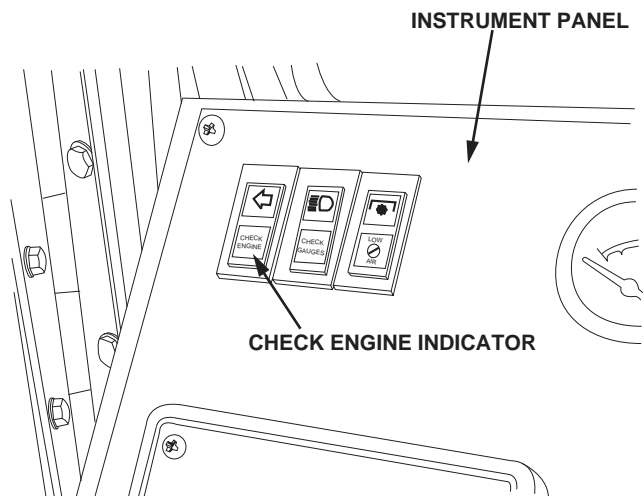
- (4) Note operation of CHECK ENGINE indicator.
- (5) Turn engine switch to OFF position.



FIRST CHART FOR DIAGNOSIS OF DDEC WHEN NO DIAGNOSTIC DATA READER (DDR) IS AVAILABLE (CONT)

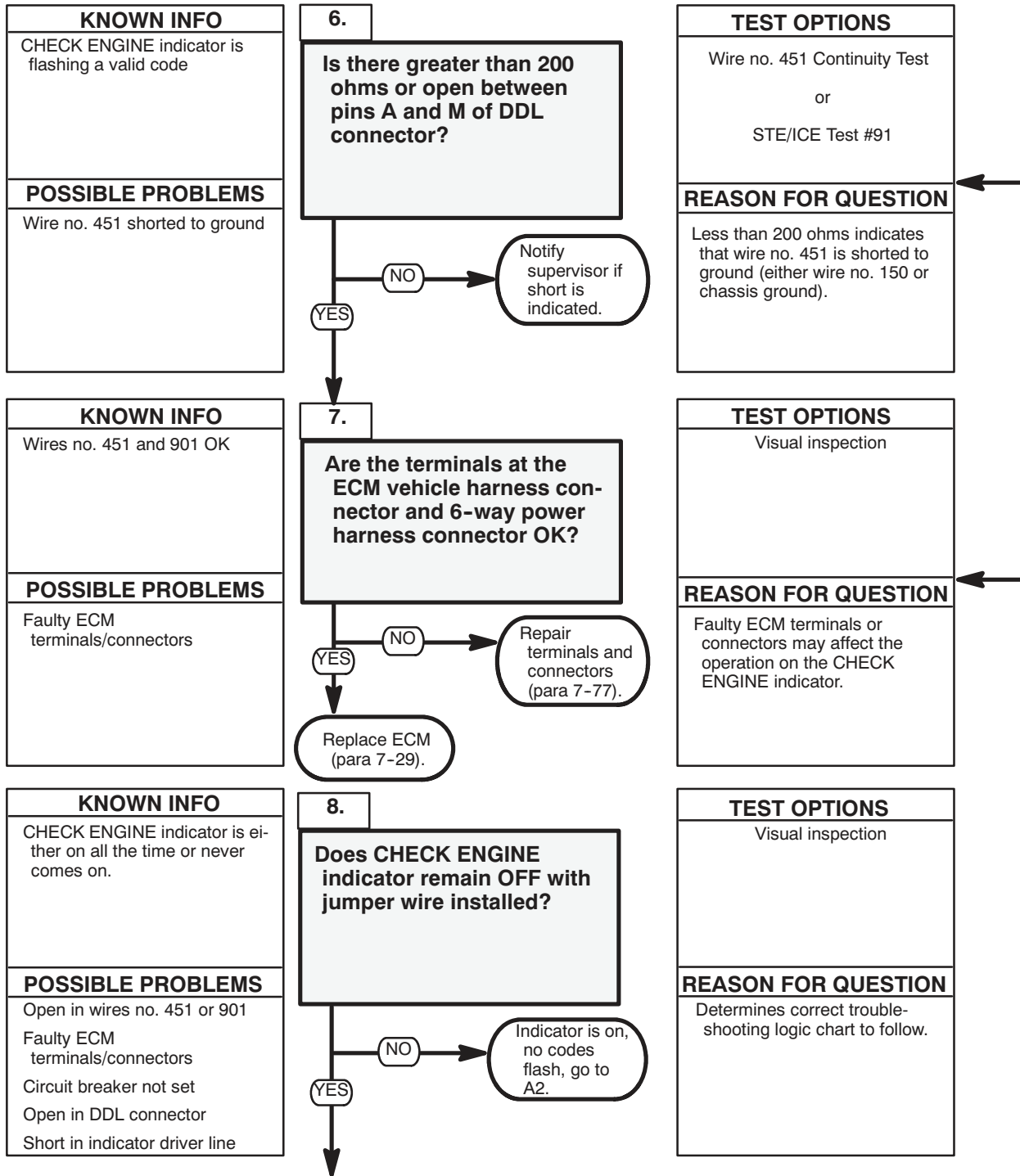


Note whether the CHECK ENGINE indicator is flashing or never comes on.



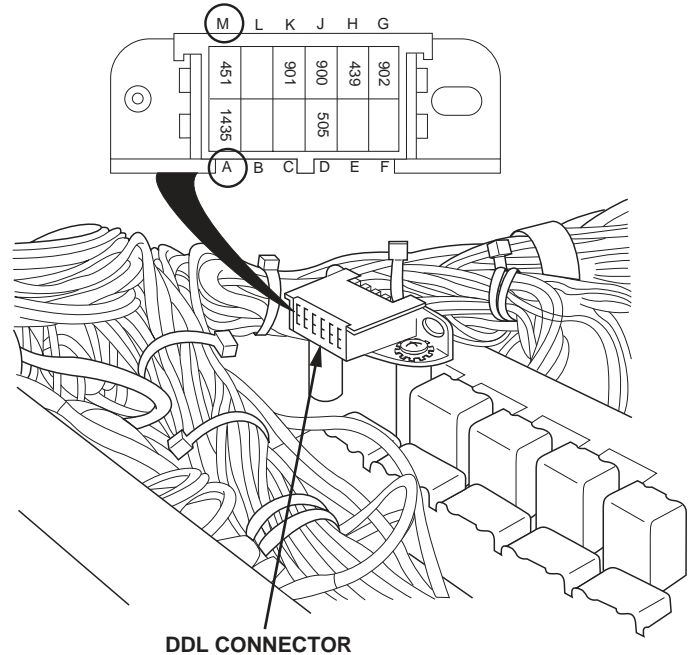
Note whether flashing CHECK ENGINE indicator is displaying a valid code or if it's just erratic or intermittent.

FIRST CHART FOR DIAGNOSIS OF DDEC WHEN NO DIAGNOSTIC DATA READER (DDR) IS AVAILABLE (CONT)

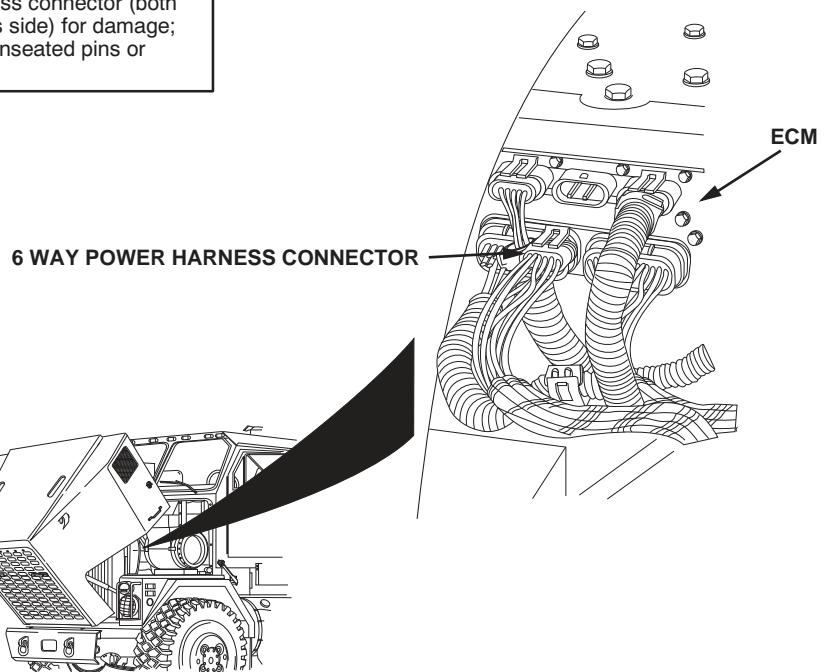


WIRE # 451 CONTINUITY TEST

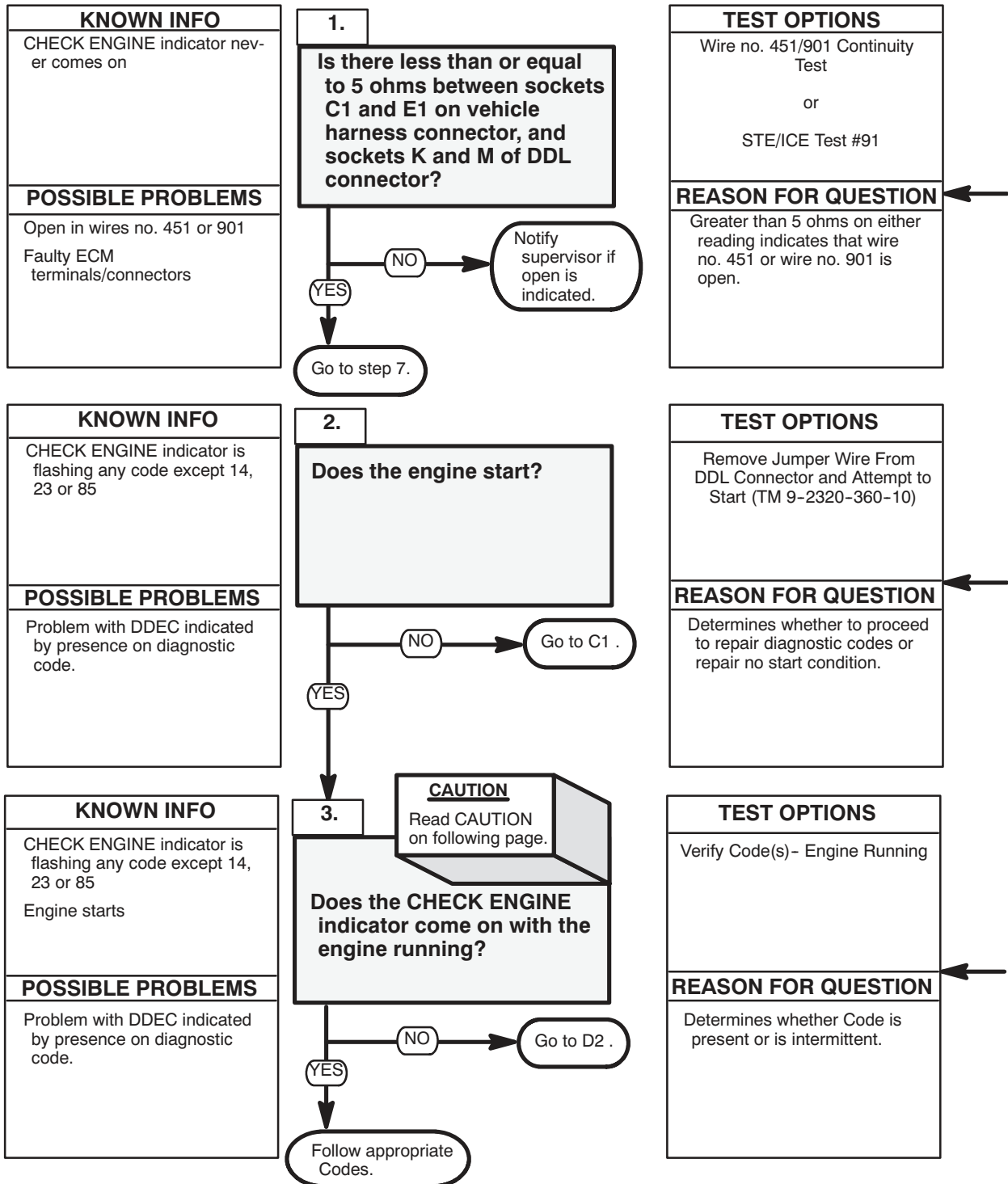
- (1) Turn ENGINE switch to OFF position (TM 9-2320-360-10).
- (2) Remove the vehicle harness connector from the ECM.
- (3) Place positive (+) probe of multimeter on pin A of DDL connector.
- (4) Place negative (-) probe of multimeter on pin M of DDL connector and note reading on multimeter.



- (1) Remove the 6-way power harness from the ECM.
- (2) Check the 6-way power harness connector and the vehicle harness connector (both the ECM and harness side) for damage; bent, corroded, and unseated pins or sockets.

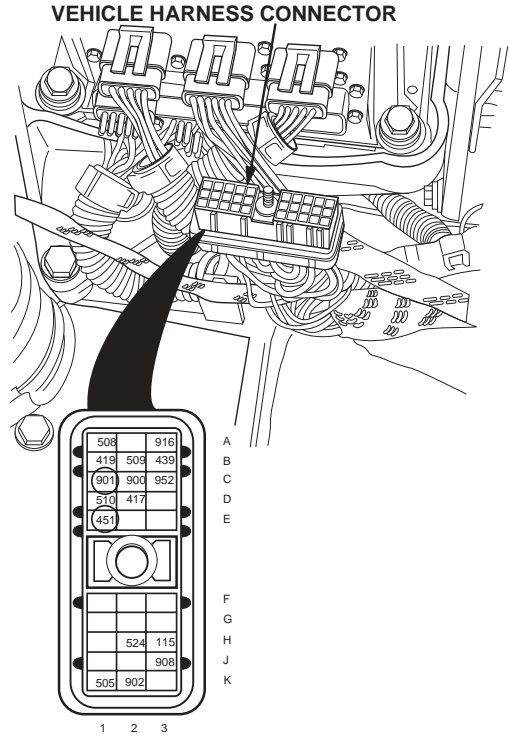


FIRST CHART FOR DIAGNOSIS OF DDEC WHEN NO DIAGNOSTIC DATA READER (DDR) IS AVAILABLE (CONT)

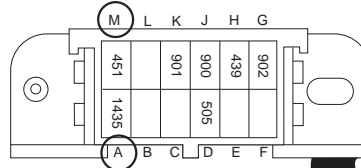


WIRE # 451/901 CONTINUITY TEST

- (1) Turn engine switch to OFF position (TM 9-2320-360-10).
- (2) Remove vehicle harness connector from ECM.
- (3) Install jumper wire between sockets C1 and E1 on the vehicle harness connector.
- (4) Place positive (+) probe of multimeter on pin K of the 12 pin DDL connector.
- (5) Place negative (-) probe of multimeter on pin M of the DDL connector and note reading on multimeter.
- (6) Place positive (+) probe of multimeter on pin A of DDL connector.
- (7) Place negative (-) probe of multimeter on known good ground and note reading on multimeter.



- (1) Remove jumper wire from between pins A and M of the DDL connector.
- (2) Attempt to start and run the engine (TM 9-2320-360-10).



VERIFY CODE(S) - ENGINE RUNNING

- (1) Try to get the CHECK ENGINE indicator to come on by warming up the engine and increasing the engine speed from idle speed to 2100 RPM.
- (2) Run engine for one minute or until CHECK ENGINE indicator comes on.
- (3) Shut off engine (TM 9-2320-360-10).

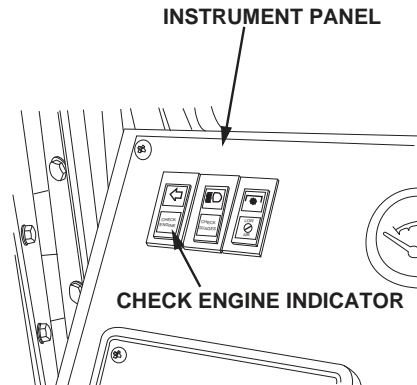
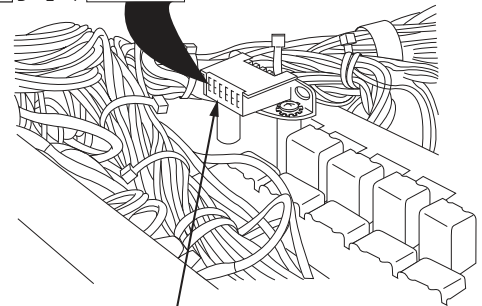
CAUTION

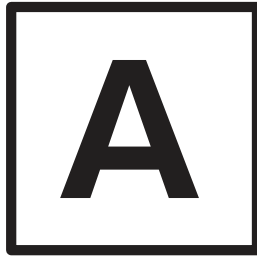
Use jumper wire only between terminals indicated. Failure to comply may result in damage to DDEC components or wiring.

NOTE

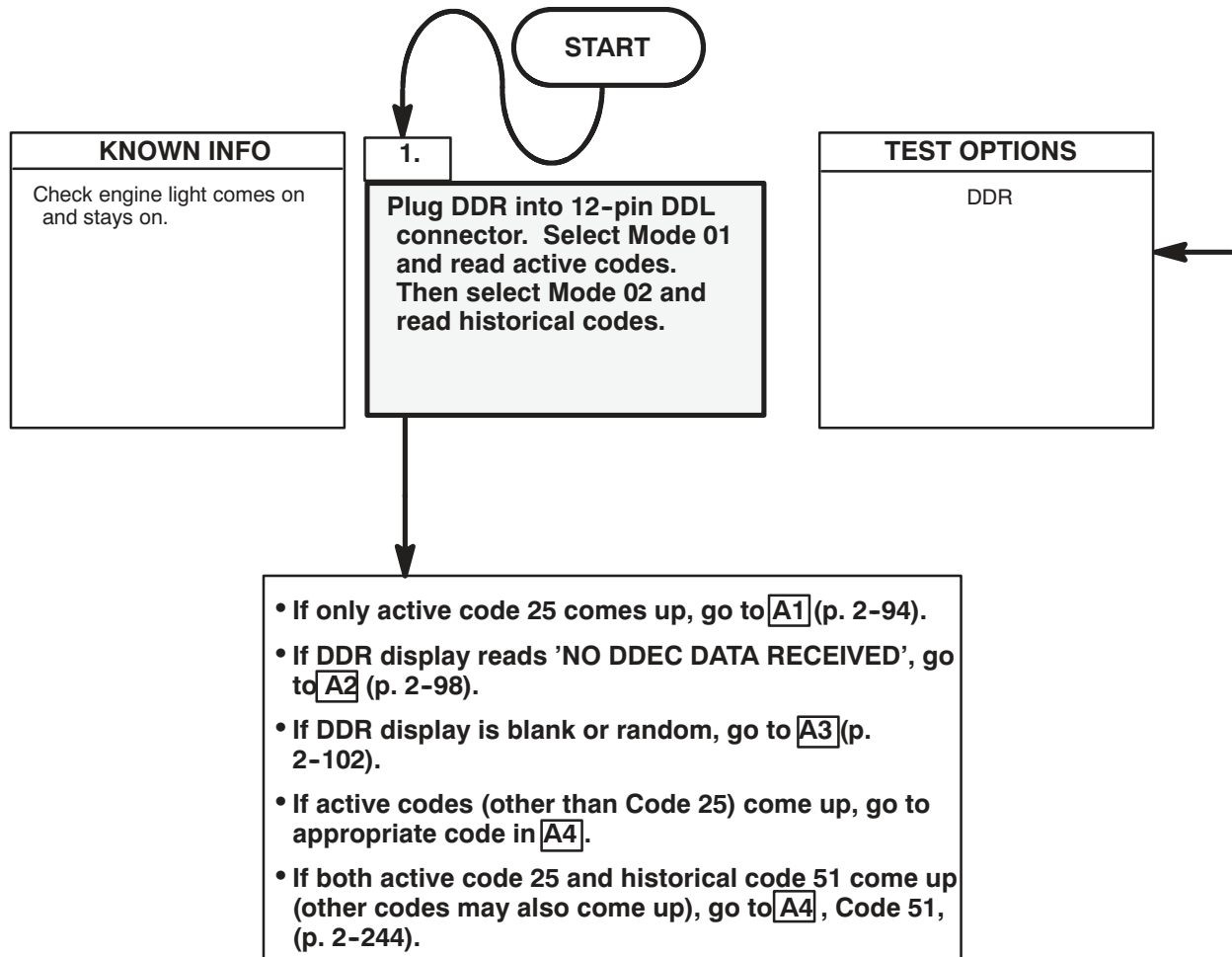
If CHECK ENGINE indicator came on, do steps (4) through (7).

- (4) Install suitable wire (paper clip) between pins A and M of the 12 pin, DDL connector.
- (5) Turn ENGINE SWITCH to ON position (TM 9-2320-360-10).
- (6) Note operation of CHECK ENGINE indicator to read codes.
- (7) Turn ENGINE SWITCH to OFF position (TM 9-2320-360-10).





A CHECK ENGINE LIGHT COMES ON AND STAYS ON

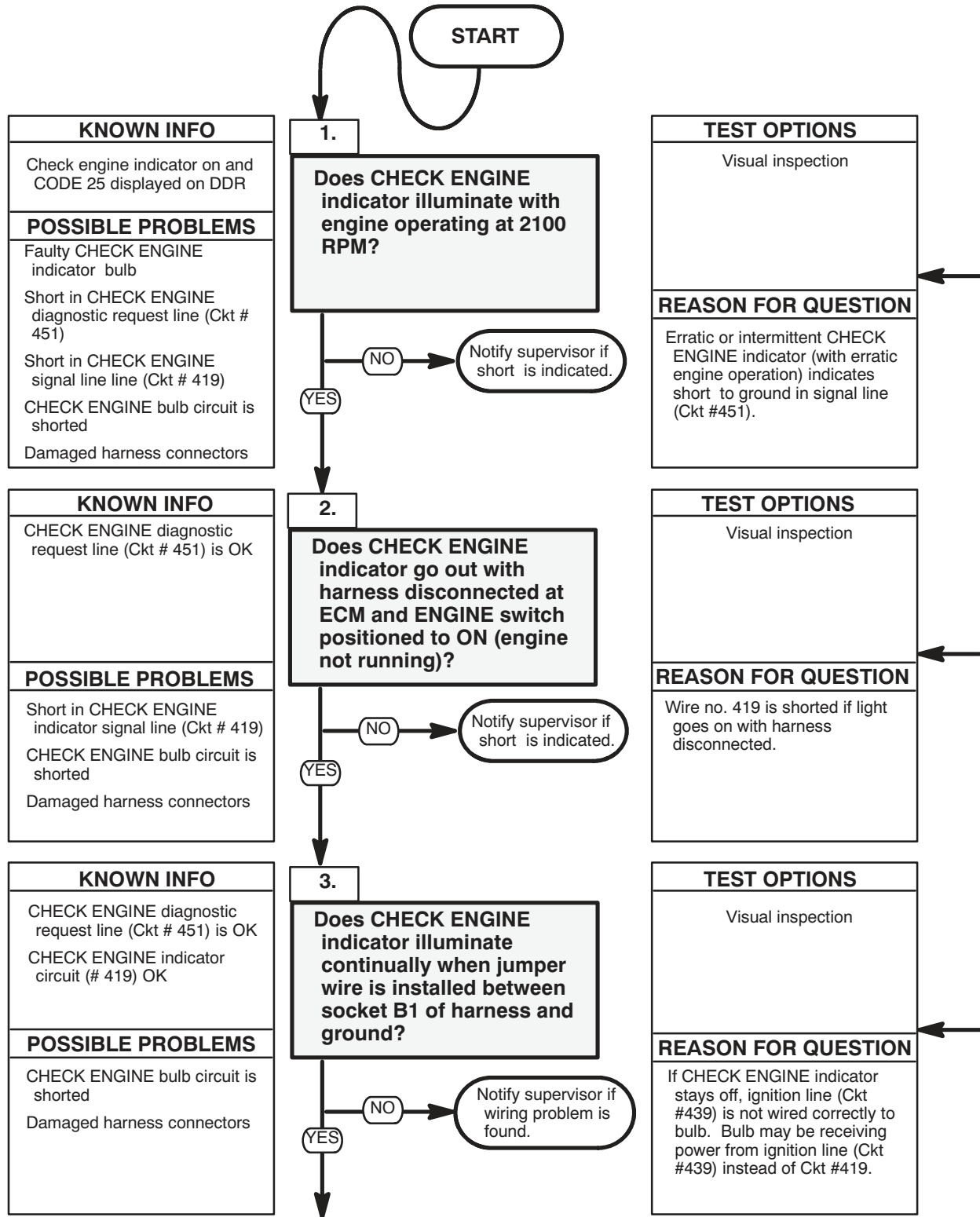




NOTE

The following flow chart should be used if DDEC troubleshooting was started on p. 2-80 and you were referred here.

A1 'CHECK ENGINE' INDICATOR ON AND CODE 25 ON DDR



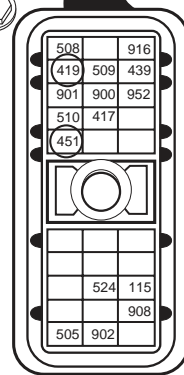
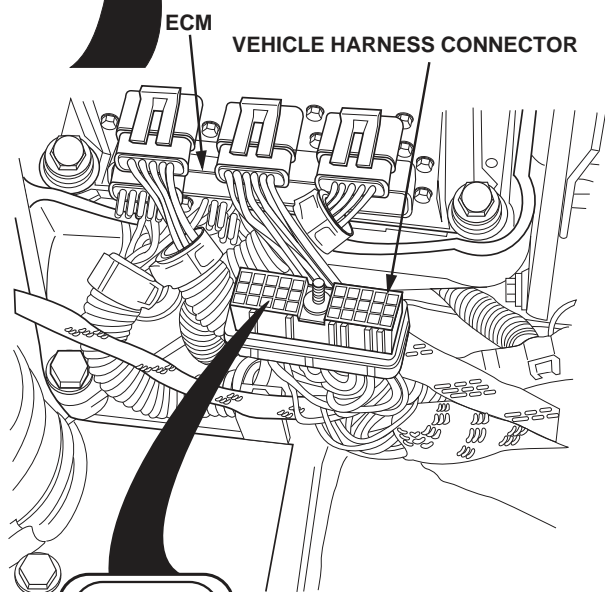
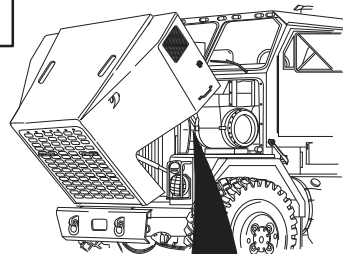
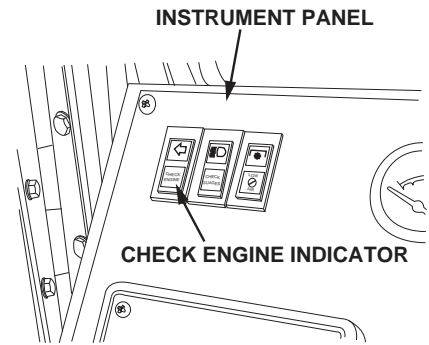
NOTE

The following flow chart should be used if DDEC troubleshooting was started on p. 2-80 and you were referred here.

- (8) Turn ENGINE switch ON. Observe CHECK ENGINE indicator.
- (9) Start engine and increase engine speed to 2100 rpm. Observe CHECK ENGINE indicator.

- (1) Turn ENGINE switch to OFF.
- (2) Disconnect vehicle harness connector at ECM.
- (3) Turn ENGINE switch to ON. Observe CHECK ENGINE indicator.

- (1) Turn ENGINE switch to OFF.
- (2) Install jumper wire between socket B1 of harness connector and ground.
- (3) Turn ENGINE switch to ON. Observe CHECK ENGINE indicator.

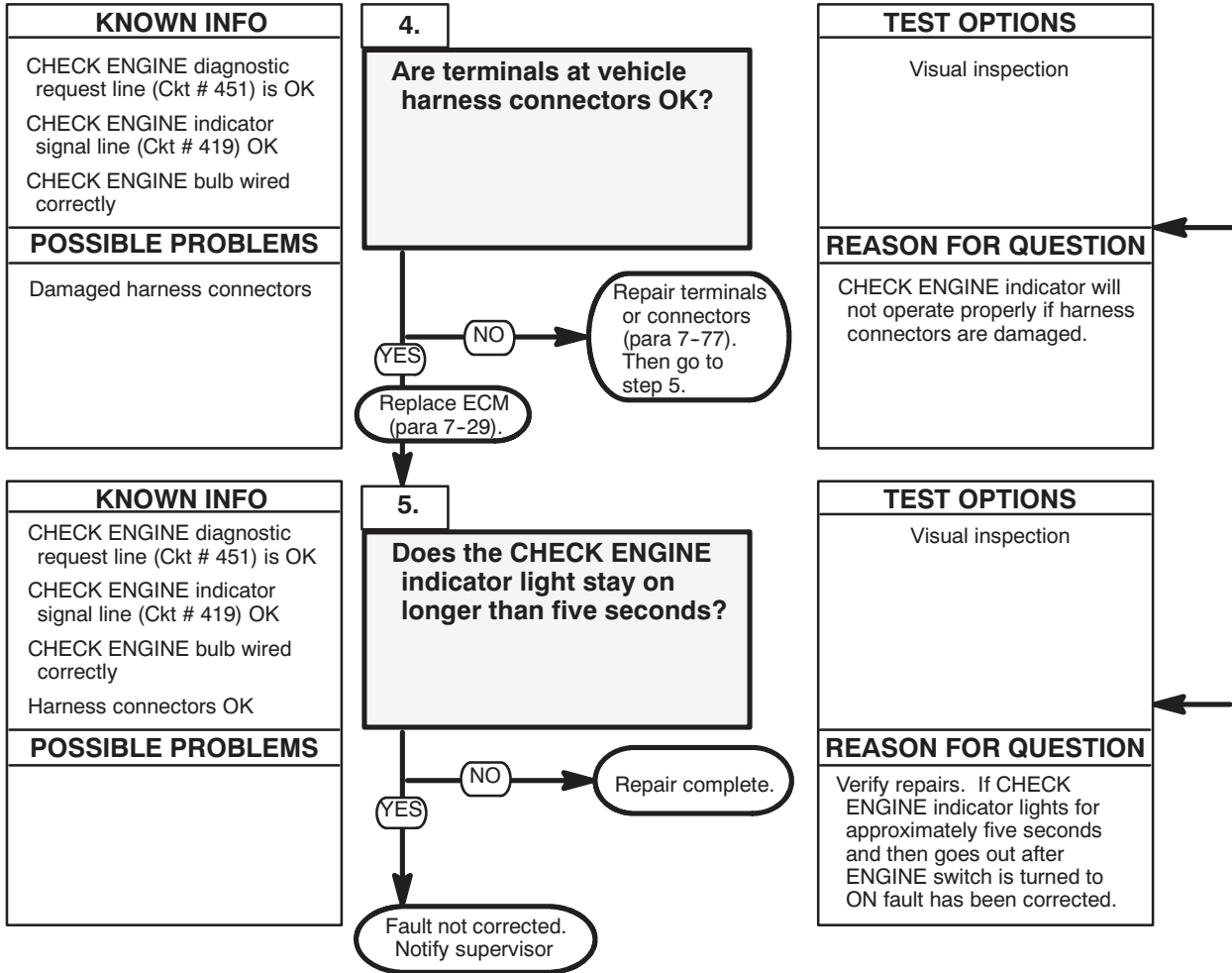


A
B
C
D
E

F
G
H
J
K

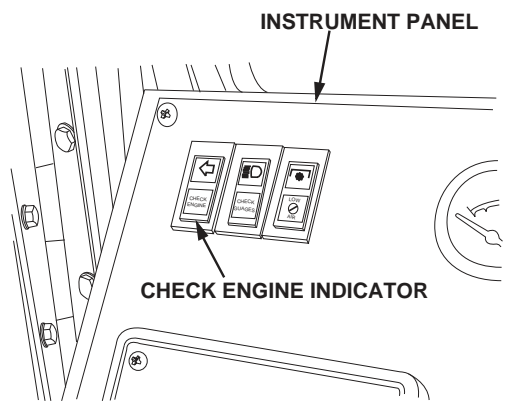
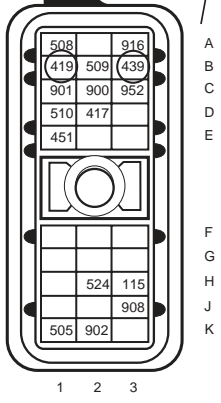
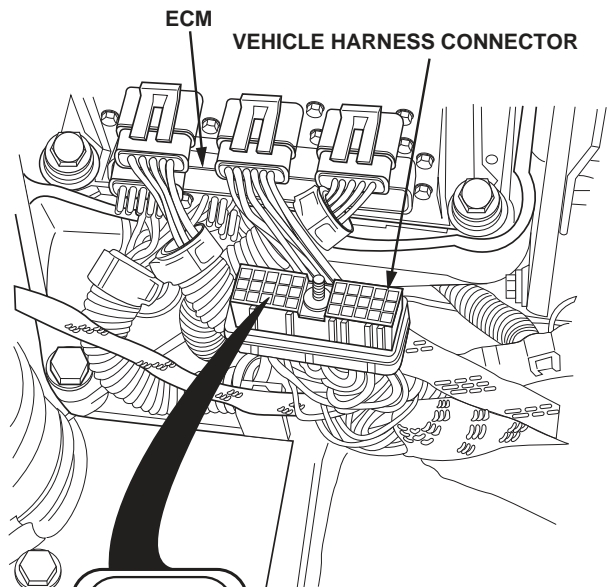
1 2 3

A1 'CHECK ENGINE' INDICATOR ON AND CODE 25 ON DDR (CONT)

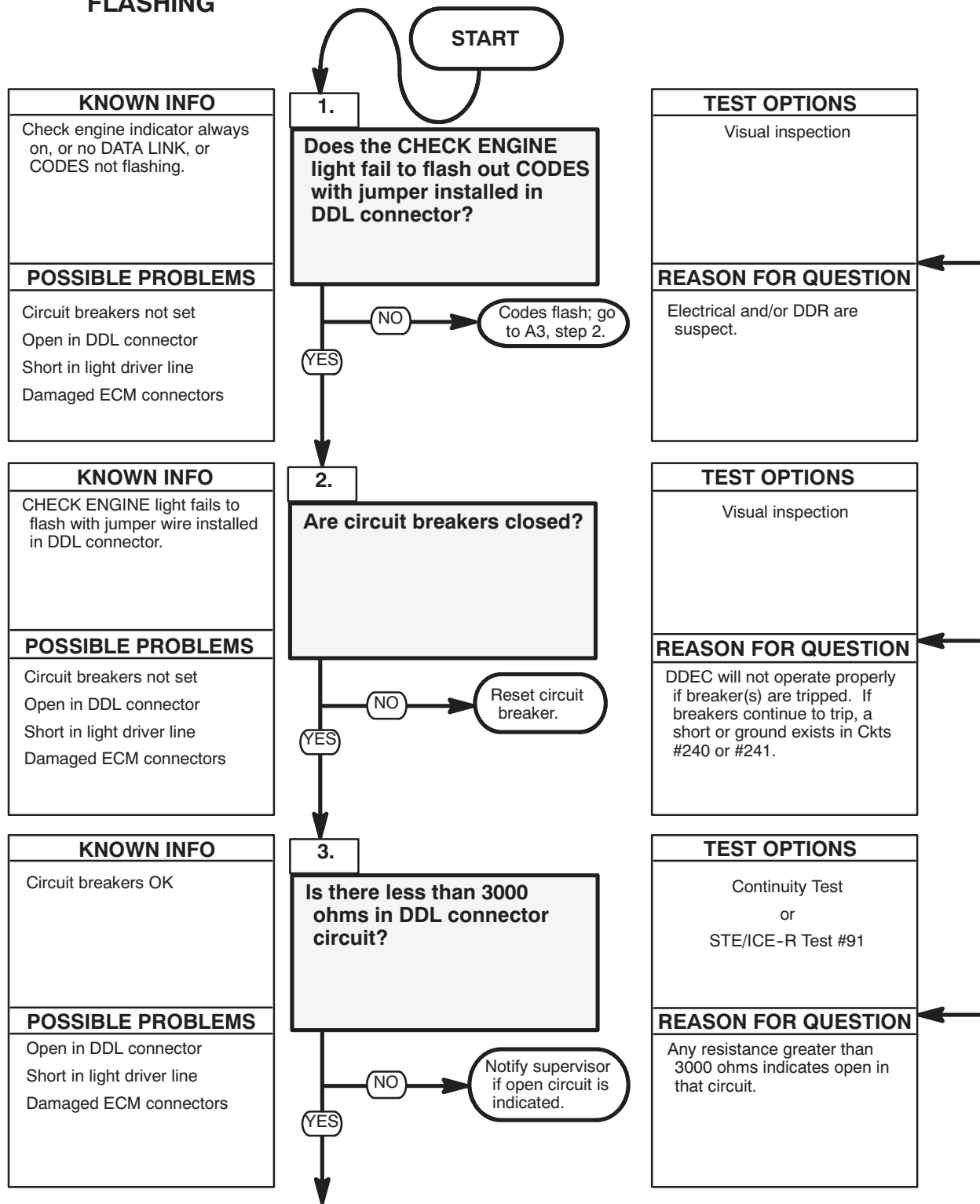


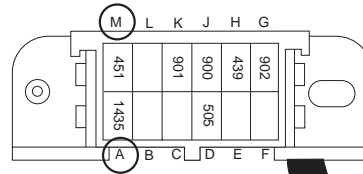
- (1) Turn ENGINE switch OFF.
- (2) Check terminals at vehicle harness connectors for damage (bent, corroded, and unseated pins or sockets).
- (3) Check terminals in connector to be sure wire no. 419 is in socket B1 and wire no. 439 is in socket B3.

- (1) Turn ENGINE switch OFF.
- (2) Reconnect all harness connectors.
- (3) Turn ENGINE switch ON and observe CHECK ENGINE indicator.



A2 'CHECK ENGINE' INDICATOR ALWAYS ON, NO DATA LINK, CODES NOT FLASHING

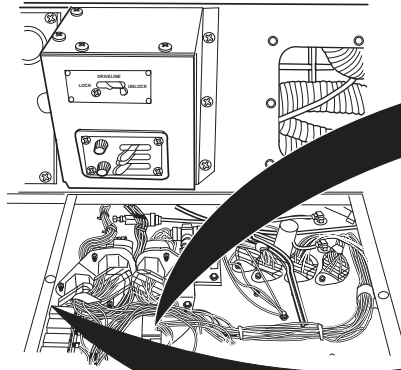
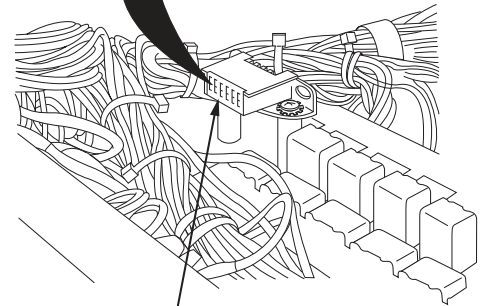




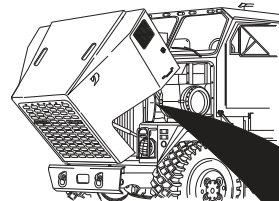
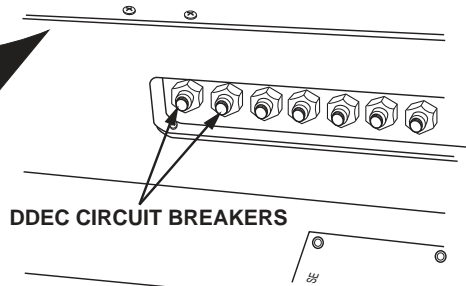
NOTE

The following flow chart should be used if DDEC troubleshooting was started on p. 2-80 and you were referred here.

- (1) Unplug DDR.
- (2) Short pin A to Pin M on 12- pin DDL connector.

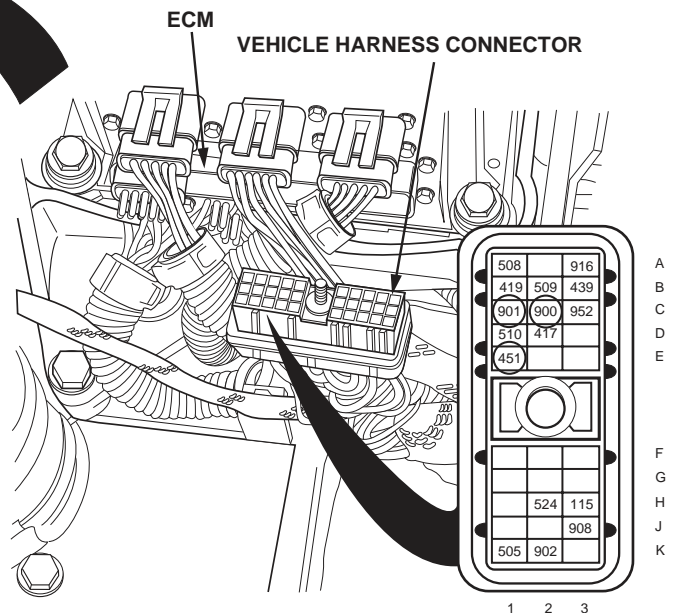


Check circuit breakers to ECM and reset if needed.

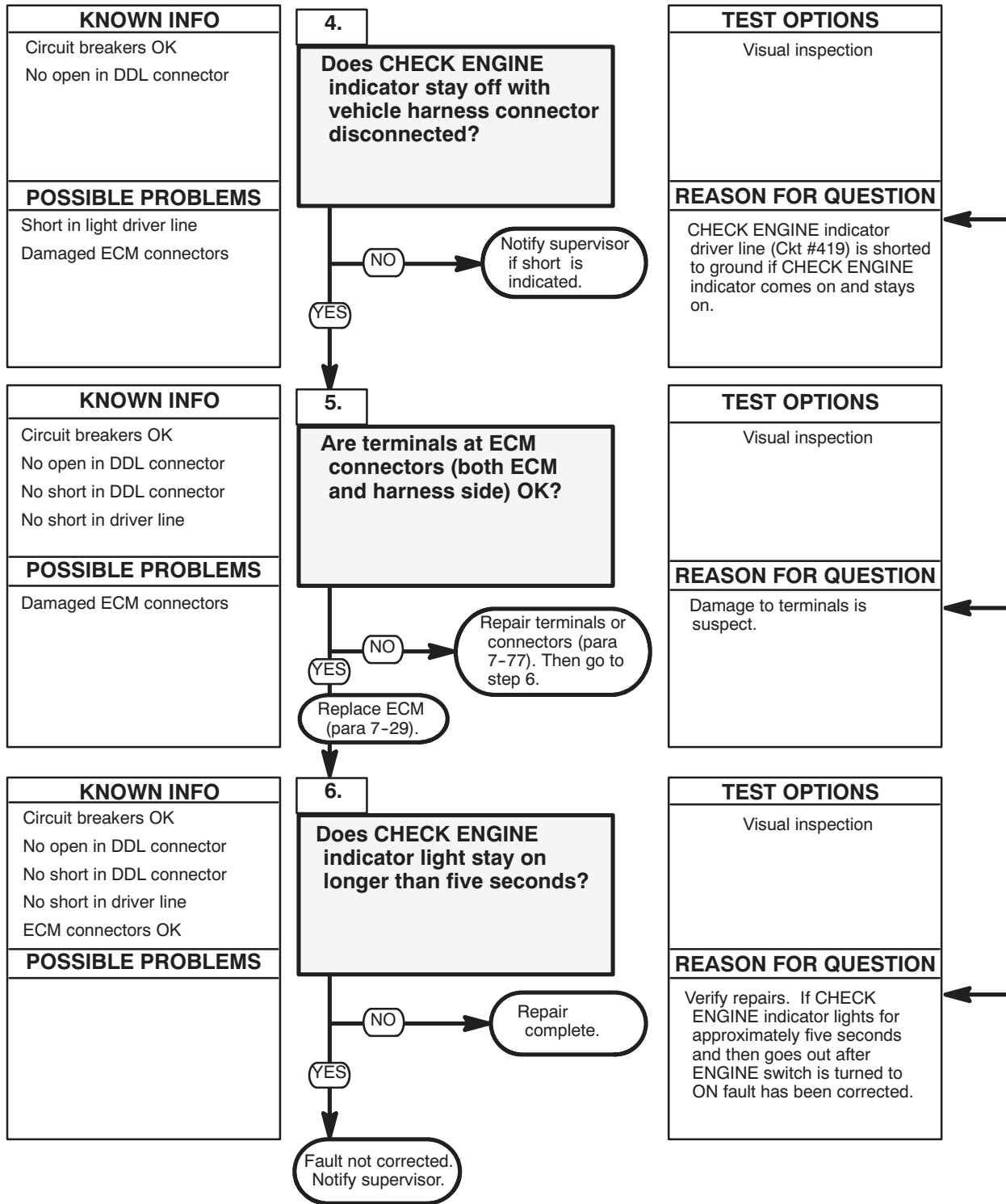


CONTINUITY TEST

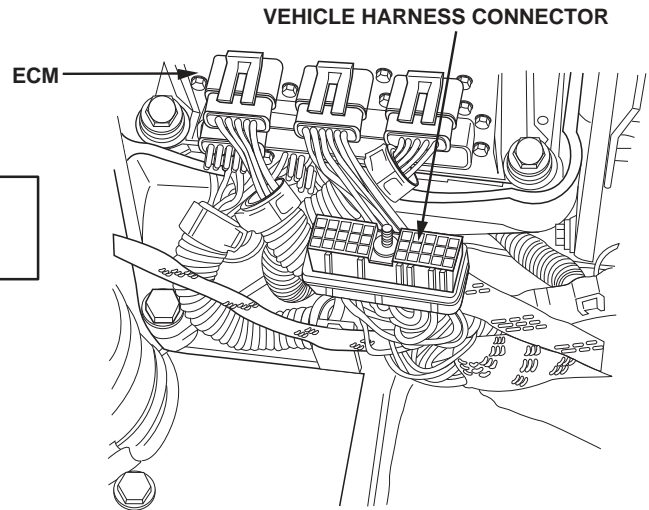
- (1) Check resistance between cavity A of DDL connector and a known good ground.
- (2) Disconnect vehicle harness connector at ECM. Check resistance between pin M of DDL and cavity E1 of ECM 30-pin connector.
- (3) Check resistance between pin J of DDL connector and cavity C2 of ECM 30-pin connector.
- (4) Check resistance between pin K of DDL connector and cavity C1 of ECM 30-pin connector.



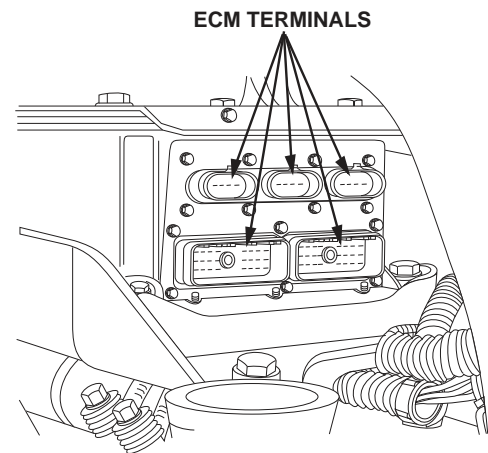
A2 'CHECK ENGINE' INDICATOR ALWAYS ON, NO DATA LINK, CODES NOT FLASHING (CONT)



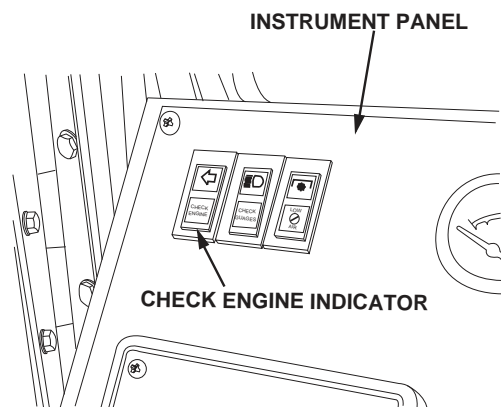
- (1) Disconnect vehicle harness connector at ECM.
- (2) Turn ENGINE switch ON (engine not running) while observing CHECK ENGINE indicator.



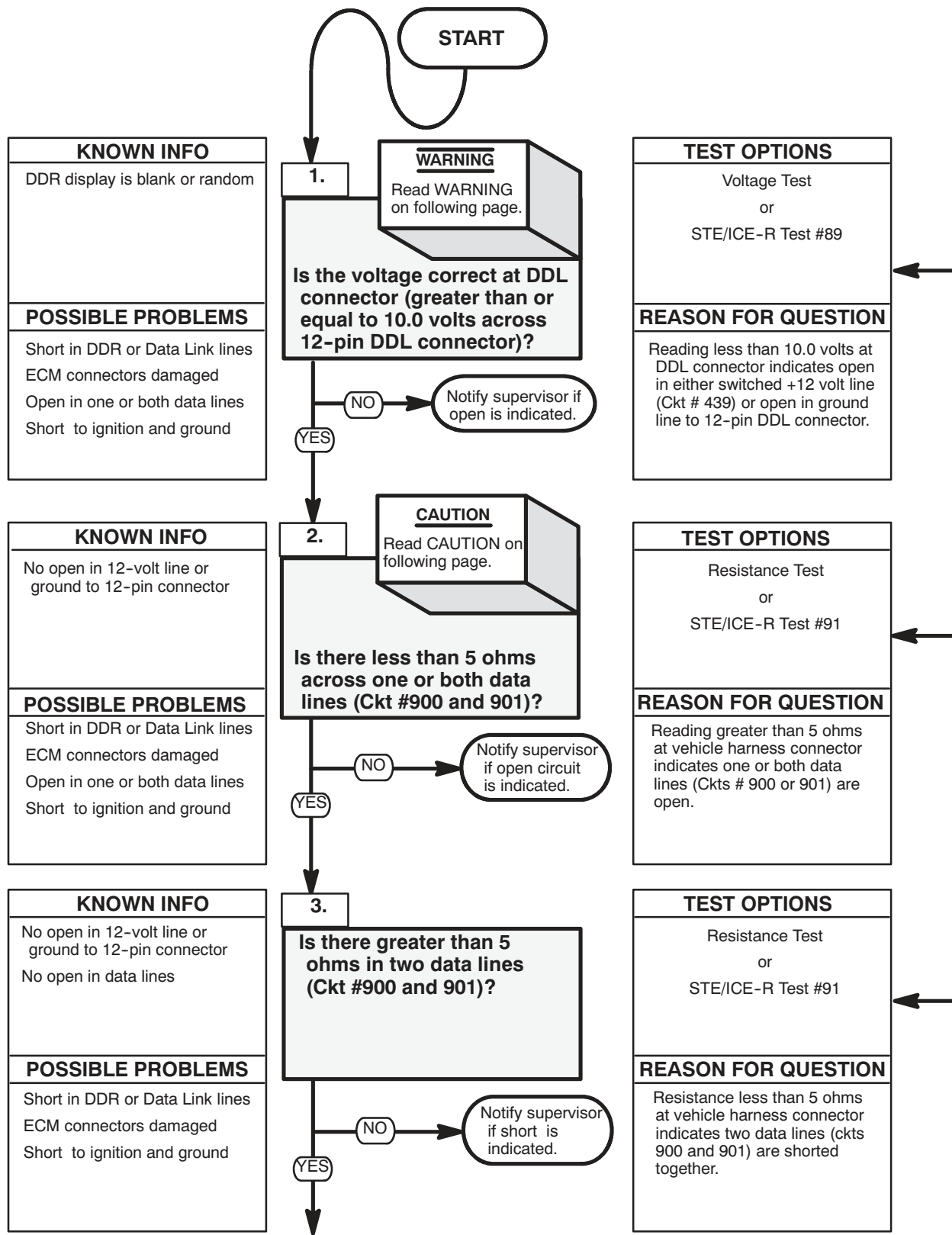
- NOTE**
- Pay special attention to terminals and sockets in 6-pin power connector and sockets B1 and B3 of 30-pin vehicle harness.
- (1) Turn ENGINE switch OFF.
 - (2) Check terminals at vehicle connectors (both ECM and harness side) for damage; bent, corroded and unseated pins or sockets.



- (1) Turn ENGINE switch OFF.
- (2) Reconnect all harness connectors.
- (3) Turn ENGINE switch ON and observe CHECK ENGINE indicator.



A3 DDR DISPLAY IS BLANK OR RANDOM



WARNING

Jewelry can catch on equipment and cause injury or short across electrical circuit and cause severe burns or electrical shock. Remove rings, bracelets, watches, necklaces, and any other jewelry before working around HET Tractor.

NOTE

The following flow chart should be used if DDEC troubleshooting was started on p. 2-80 and you were referred here.

VOLTAGE TEST

- (1) Turn ENGINE switch ON.
- (2) Read voltage at 12-pin DDL connector from pin H (red lead) to pin A (black lead).

CAUTION

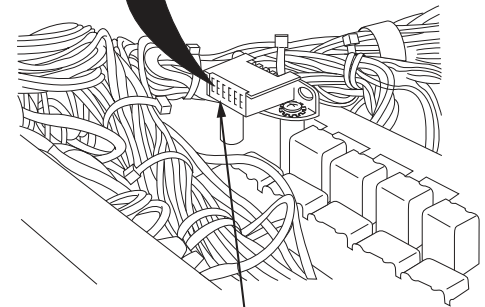
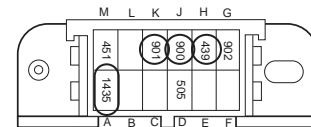
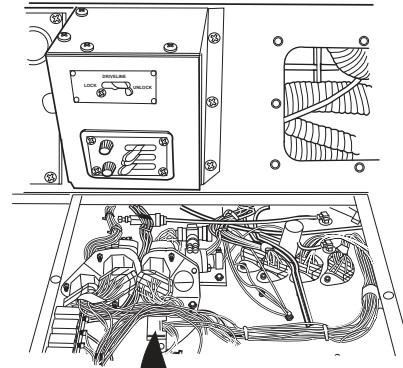
Use jumper wire only between terminals indicated. Failure to comply may result in damage to DDEC components or wiring.

RESISTANCE TEST

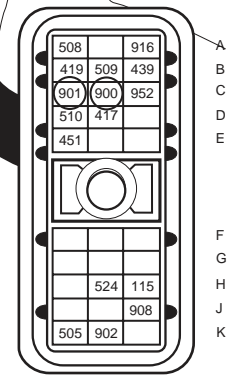
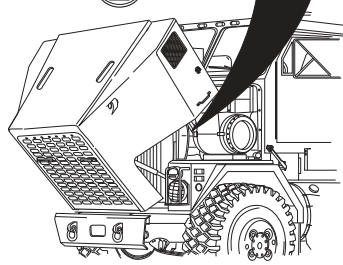
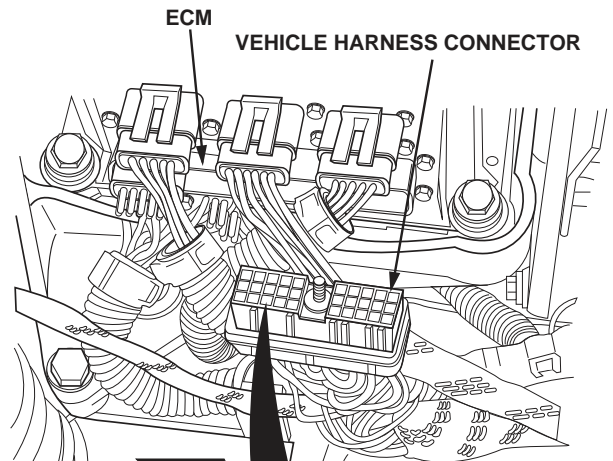
- (1) Turn ENGINE switch OFF and remove jumpers from 12-pin DDL connector.
- (2) Place jumper across pins J and K on 12-pin connector.
- (3) Unplug vehicle harness connector and measure resistance between sockets C1 and C2.

RESISTANCE TEST

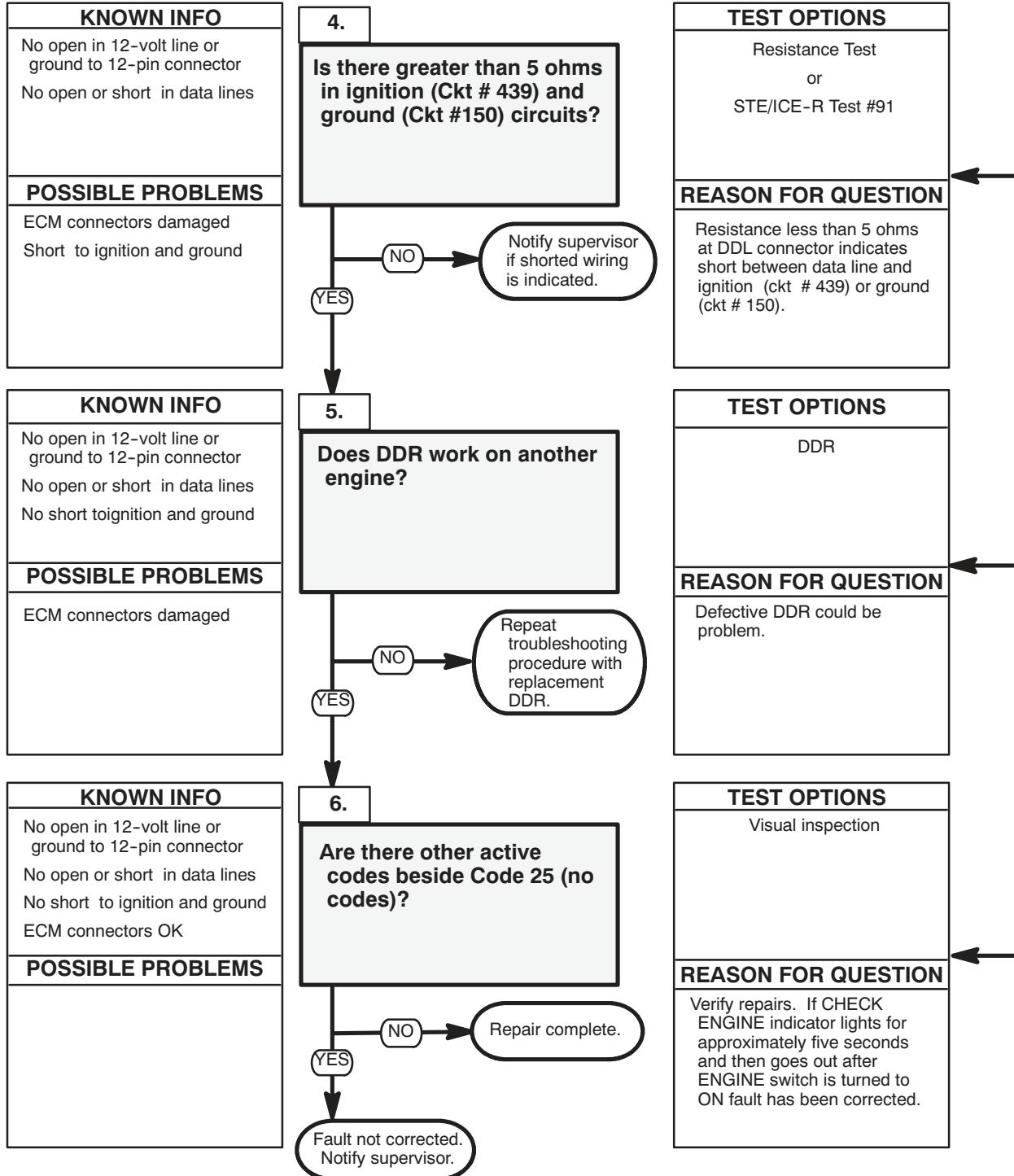
- (1) Remove jumpers from 12-pin DDL connector.
- (2) Read resistance between sockets C1 and C2 of vehicle harness connector.



DDL CONNECTOR

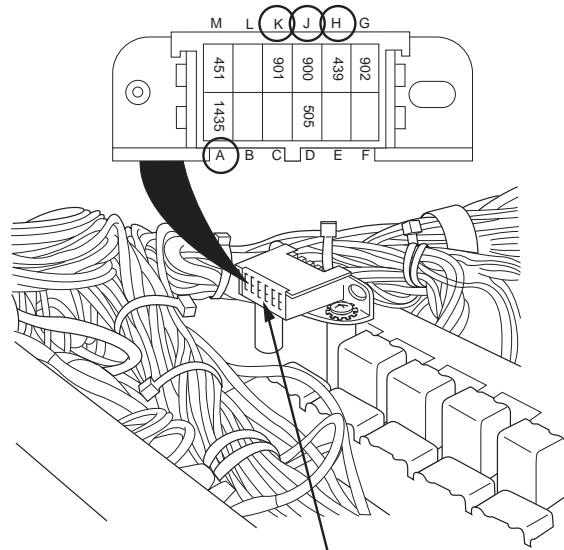


A3 DDR DISPLAY IS BLANK OR RANDOM (CONT)



RESISTANCE TEST

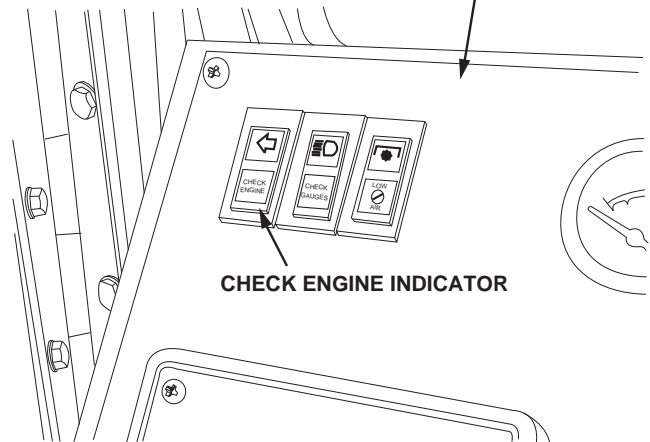
- (1) Remove all jumpers from 12-pin DDL connector.
- (2) Measure resistance between sockets J and A, then J and H next. Measure resistance between sockets K and A, then K and H of DDL connector.



DDL CONNECTOR

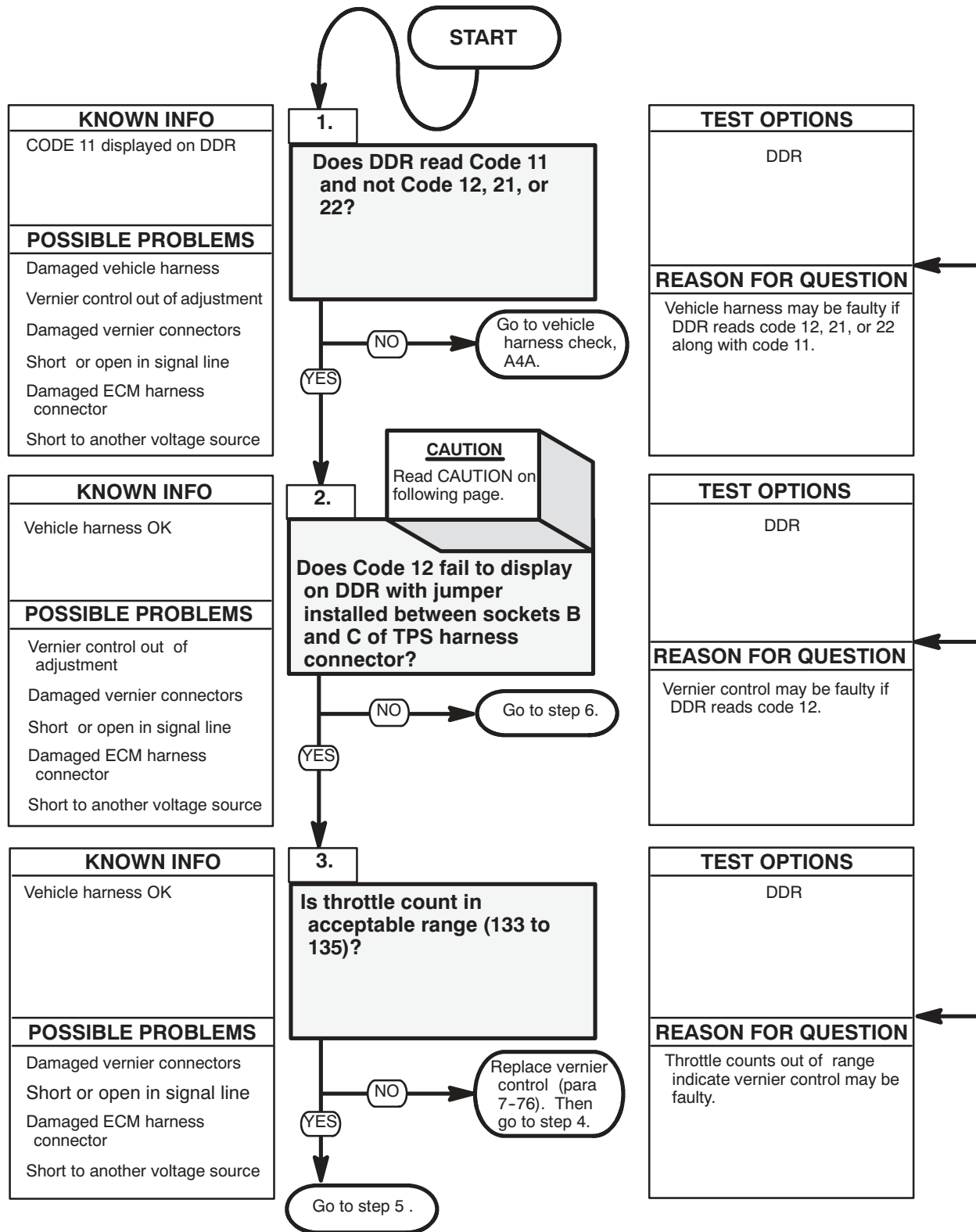
- (1) Connect DDR to another engine
- (2) Read PROM ID or any other parameter in menu.

INSTRUMENT PANEL



- (1) Turn ENGINE switch OFF.
- (2) Reconnect all harness connectors.
- (3) Turn ENGINE switch ON and observe CHECK ENGINE indicator.

A4 Code 11-VERNIER CONTROL SIGNAL VOLTAGE LOW



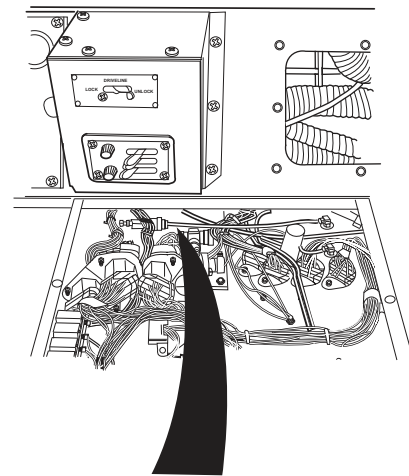
NOTE

The following flow chart should be used if DDEC troubleshooting was started on p. 2-80 and you were referred here.

CAUTION

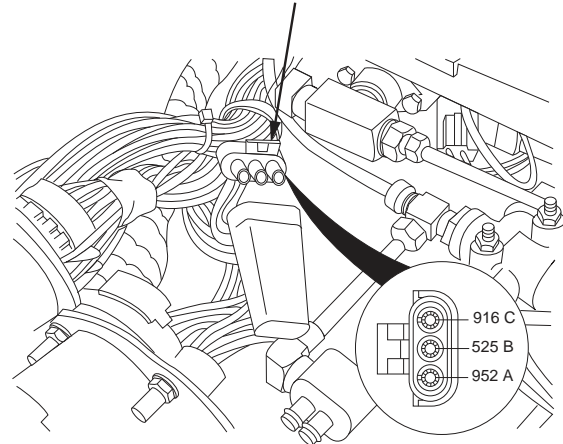
Use jumper wire only between terminals indicated. Failure to comply may result in damage to DDEC components or wiring.

- (1) Turn ENGINE switch OFF.
- (2) Disconnect vernier control connector.
- (3) Install jumper wire between sockets B and C of TPS harness connector.
- (3.1) Click on "Alarms Clear" to clear alarms screen.
- (4) Turn ENGINE switch to ON and read active codes on DDR.

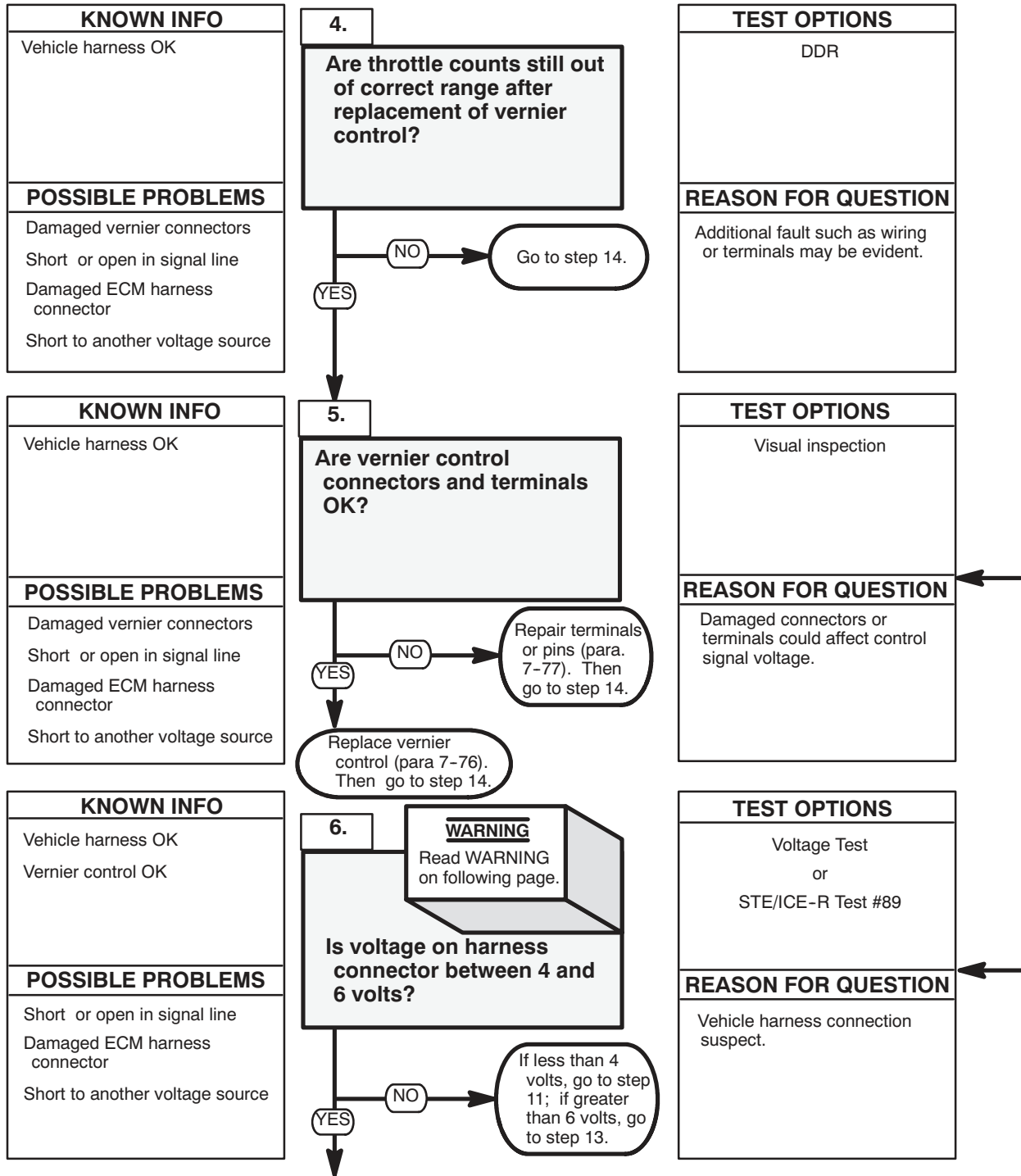


VERNIER CONTROL HARNESS CONNECTOR

- (1) Remove jumper and reconnect vernier control.
- (2) Hook DDR to 12-pin DDL connector and select PTO counts (Mode 21).
- (3) Read PTO counts.



A4 Code 11-VERNIER CONTROL SIGNAL VOLTAGE LOW (CONT)



Inspect terminals at vernier control connector (sensor side and harness side) for damage; bent, corroded, and unseated pins or sockets

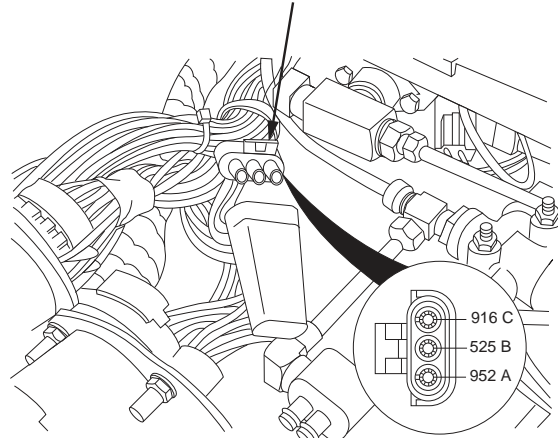
WARNING

Jewelry can catch on equipment and cause injury or short across electrical circuit and cause severe burns or electrical shock. Remove rings, bracelets, watches, necklaces, and any other jewelry before working around HET Tractor.

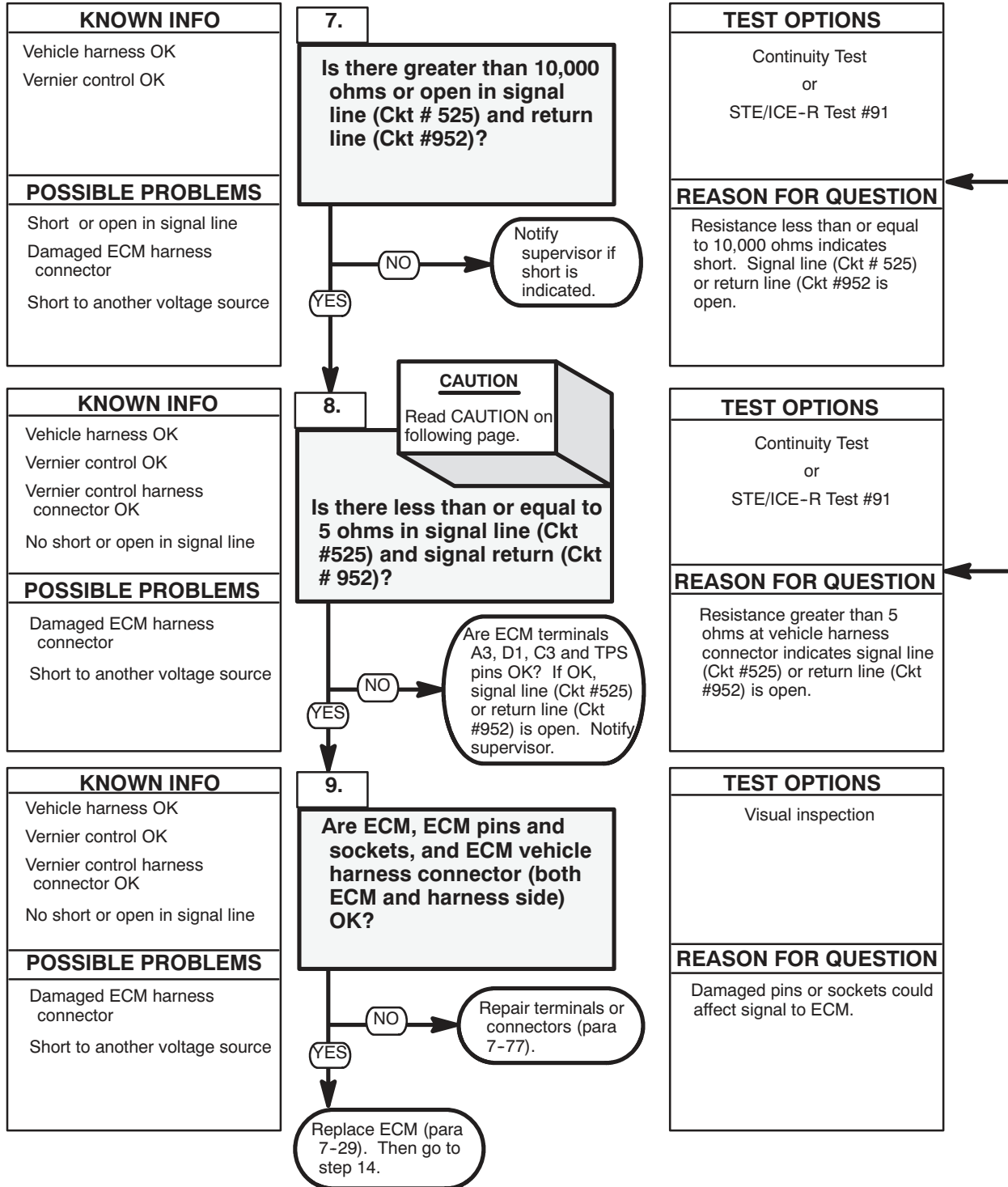
VOLTAGE TEST

- (1) Remove jumper.
- (2) Turn ENGINE switch ON.
- (3) Read voltage on vernier control harness connector between sockets C and A.

VERNIER CONTROL HARNESS CONNECTOR



A4 Code 11-VERNIER CONTROL SIGNAL VOLTAGE LOW (CONT)



CONTINUITY TEST

- (1) Turn ENGINE switch OFF.
- (2) Disconnect vehicle harness connector at ECM.
- (3) Read resistance between sockets A and B on the vernier control harness connector.

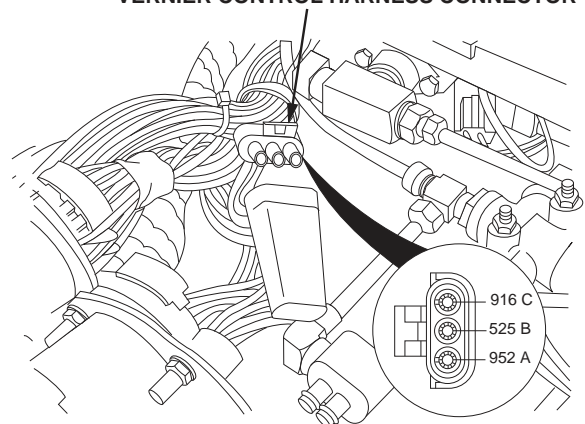
CAUTION

Use jumper wire only between terminals indicated. Failure to comply may result in damage to DDEC components or wiring.

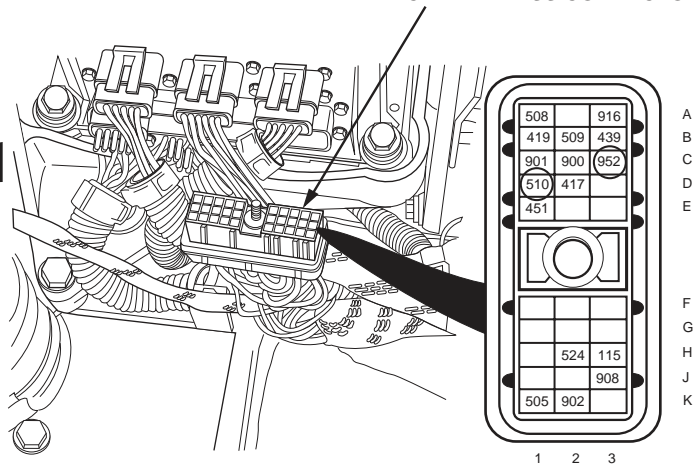
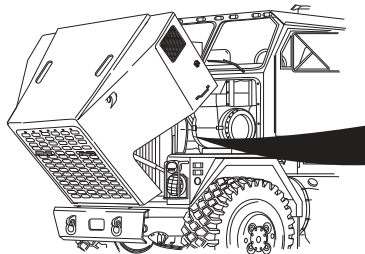
CONTINUITY TEST

- (1) Install a jumper wire between sockets A and B of Vernier Control harness connector.
- (2) Read resistance between sockets D1 and C3 on vehicle harness connector.

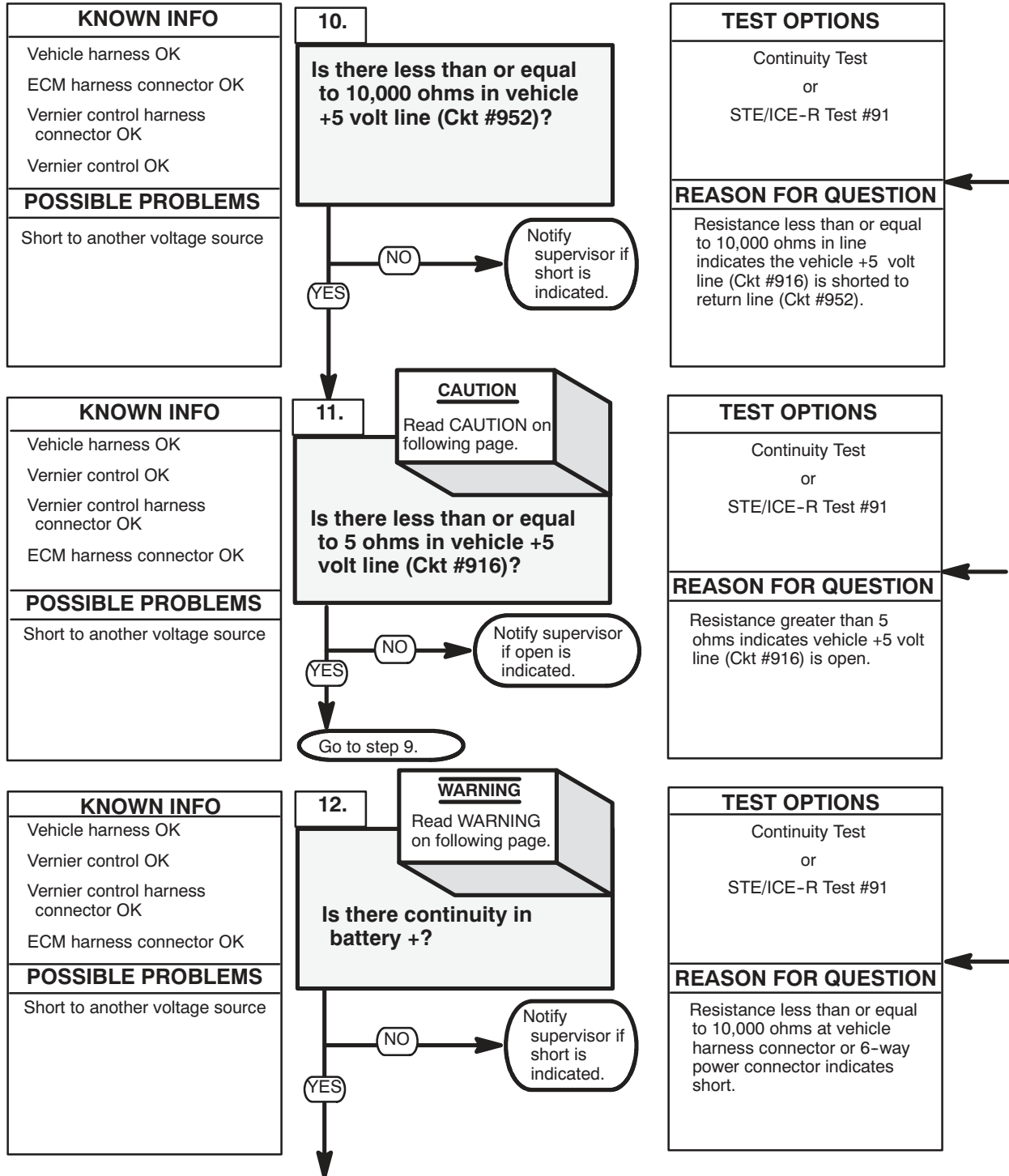
VERNIER CONTROL HARNESS CONNECTOR

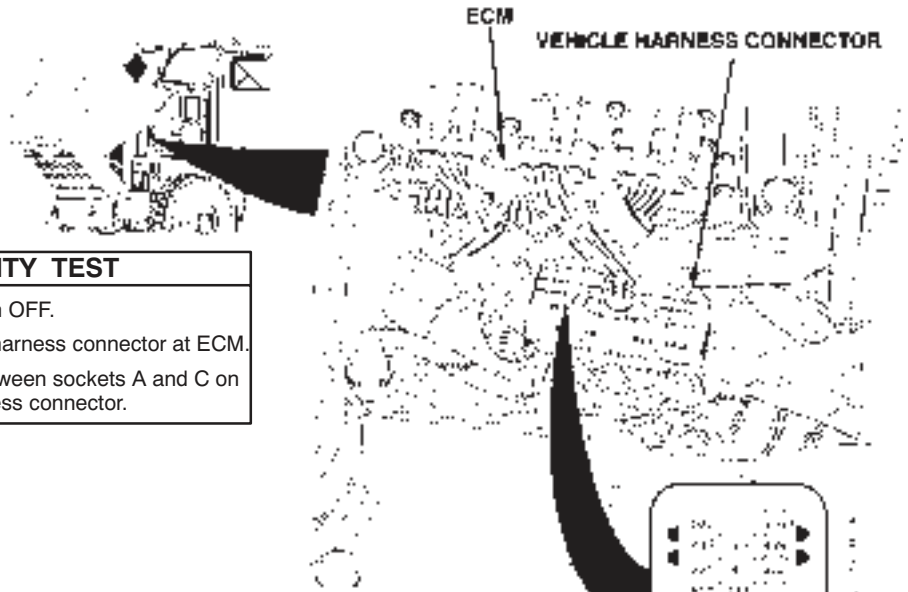


VEHICLE HARNESS CONNECTOR



A4 - Code 11 VERNIER CONTROL SIGNAL VOLTAGE LOW (CONT)





CONTINUITY TEST

- (1) Turn ENGINE switch OFF.
- (2) Disconnect vehicle harness connector at ECM.
- (3) Read resistance between sockets A and C on vernier control harness connector.

CAUTION

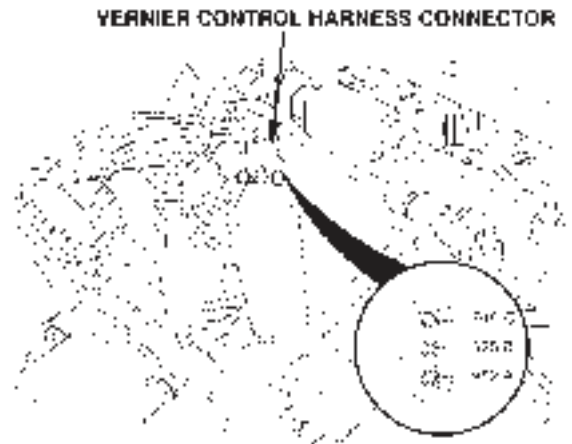
Use jumper wire only between terminals indicated. Failure to comply may result in damage to DDEC components or wiring.

CONTINUITY TEST

- (1) Install a jumper wire between sockets A and C of Vernier Control harness connector.
- (2) Read resistance between sockets A3 and C3 on vehicle harness connector.

WARNING

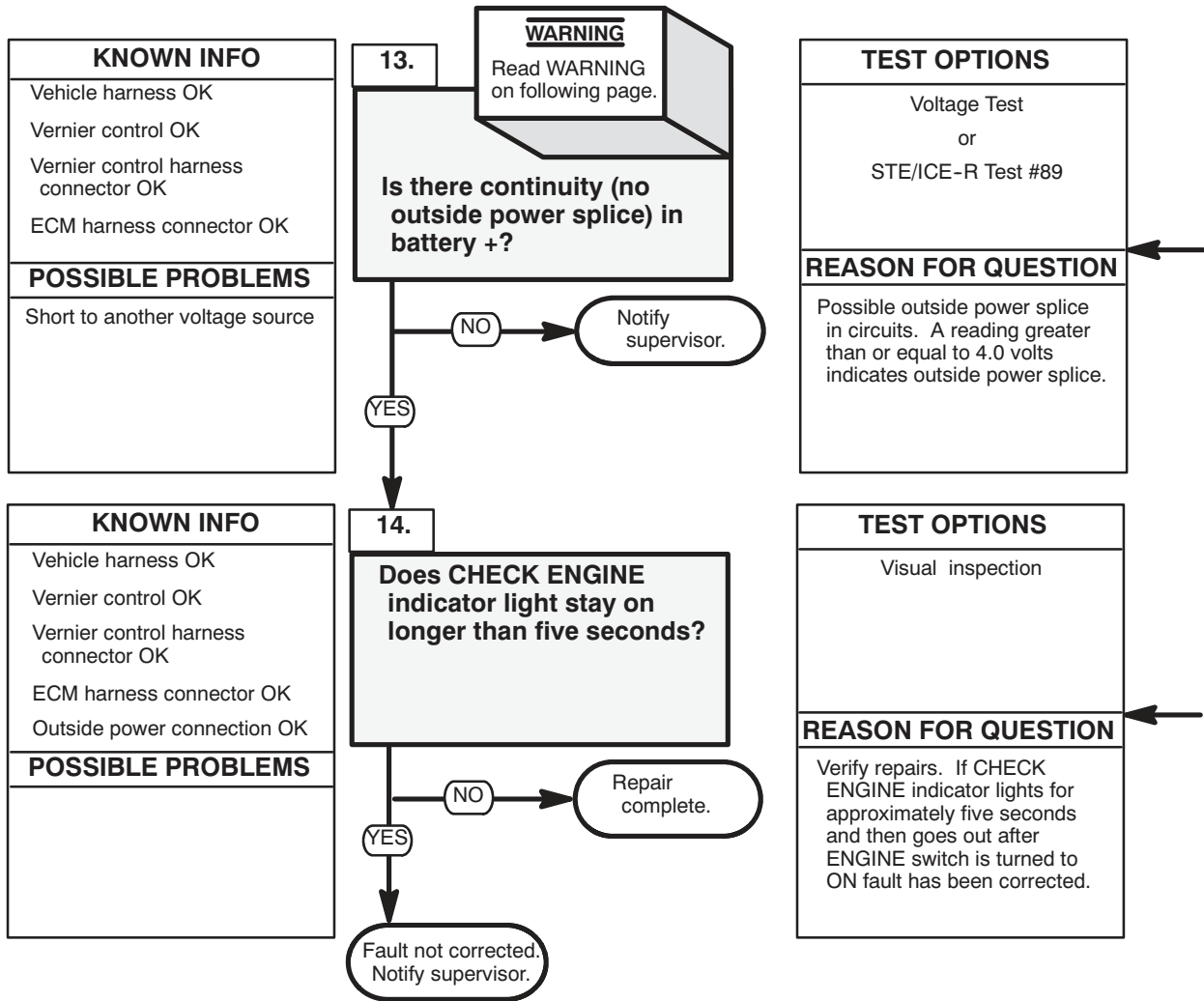
- Batteries must be disconnected before tightening any connections. Failure to comply may result in injury to personnel.
- Remove all jewelry such as rings, dog tags, bracelets, etc. If jewelry contacts electrical terminals a direct short may result in an instant heating of tools, damage to equipment, and injury to personnel.



CONTINUITY TEST

- (1) Turn ENGINE switch OFF and disconnect batteries (para 7-61).
- (2) Disconnect 6-way power connector at ECM.
- (3) Read resistance between sockets D1 and B3 on vehicle harness connector.
- (4) Read resistance between socket D1 on vehicle harness connector and sockets C, D, E, and F on 6-way power harness connector.
- (5) Connect batteries (para 7-61).

A4 - Code 11 VERNIER CONTROL SIGNAL VOLTAGE LOW (CONT)



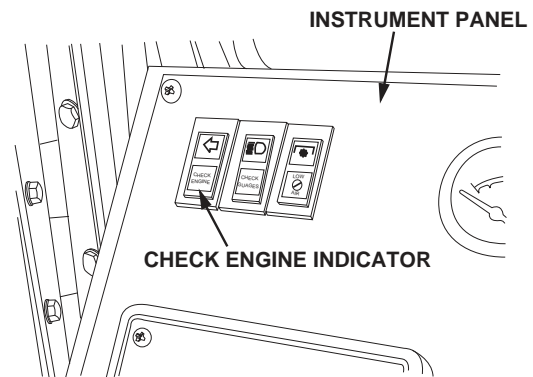
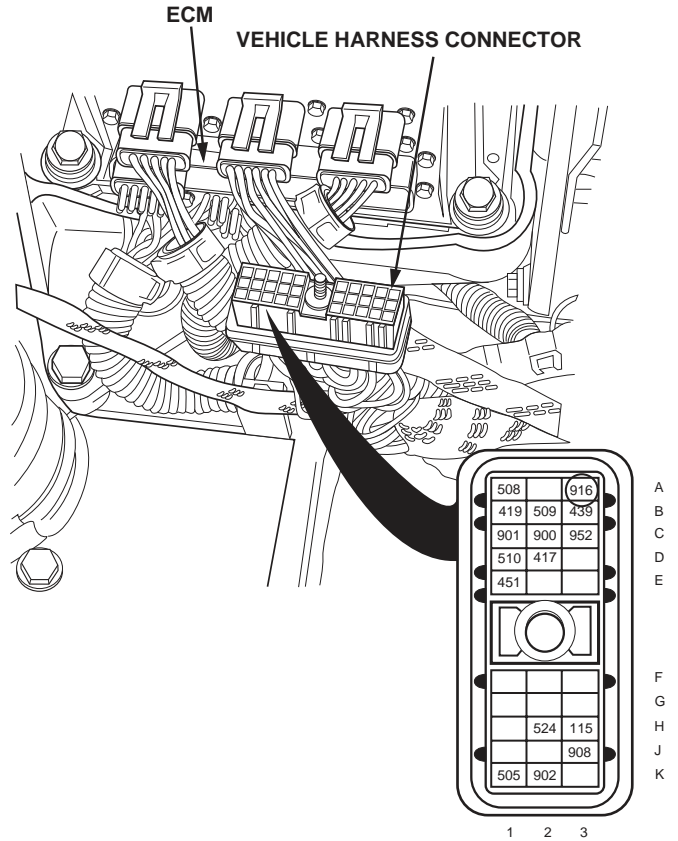
WARNING

Jewelry can catch on equipment and cause injury or short across electrical circuit and cause severe burns or electrical shock. Remove rings, bracelets, watches, necklaces, and any other jewelry before working around HET Tractor.

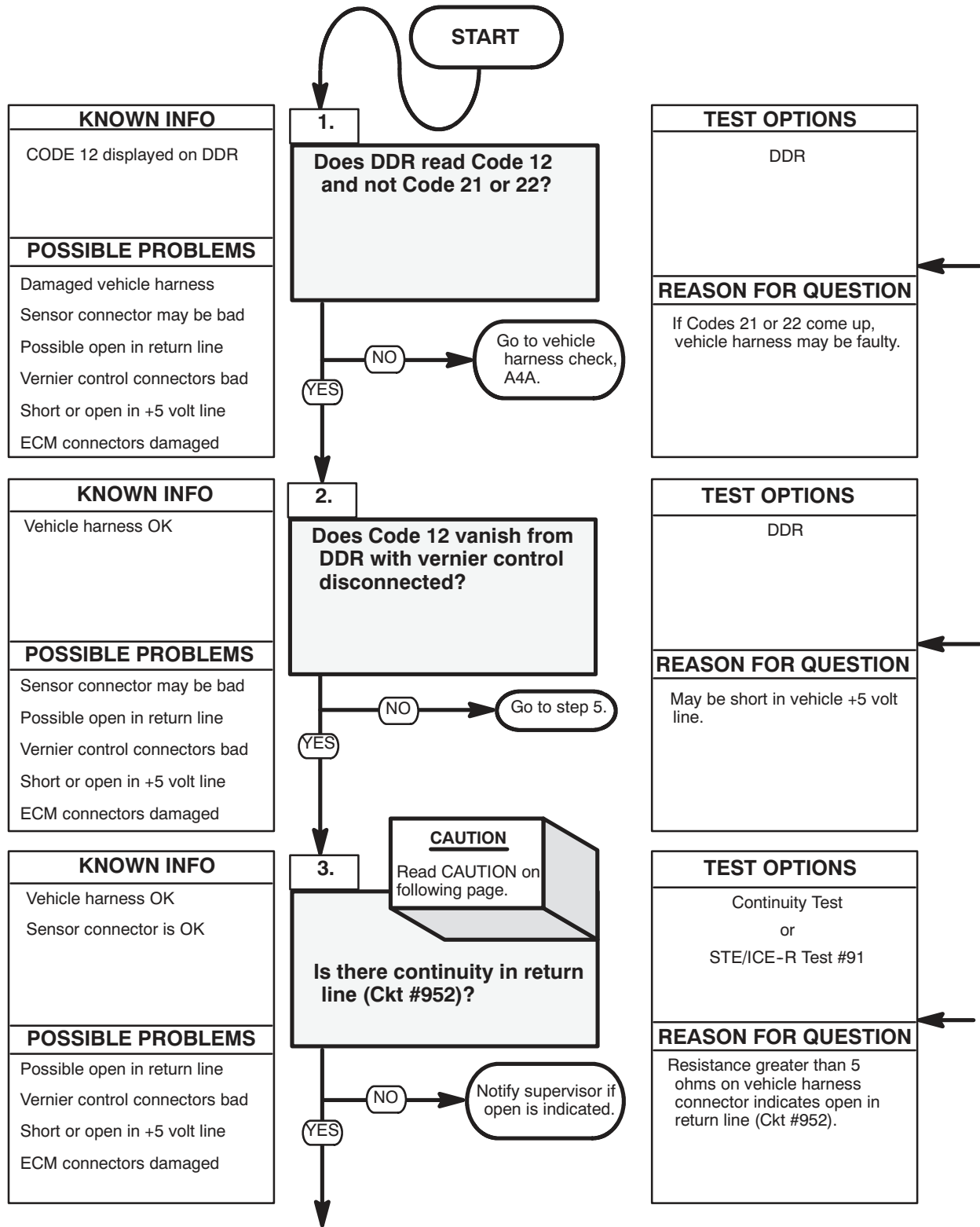
VOLTAGE TEST

- (1) Turn ENGINE switch ON.
- (2) Read voltage A3 (red lead) to a good ground (black lead).
- (3) Read voltage C3 (red lead) to good ground (black lead).

- (1) Turn ENGINE switch OFF.
- (2) Reconnect all harness connectors.
- (3) Turn ENGINE switch ON and observe CHECK ENGINE indicator.

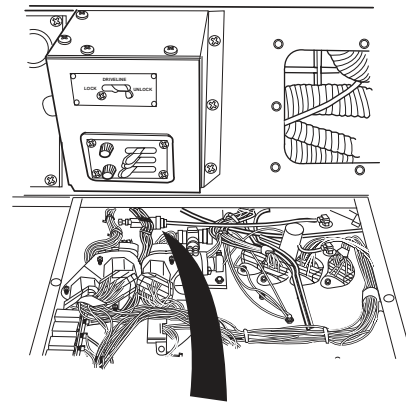


A4 - CODE 12 VERNIER CONTROL SIGNAL VOLTAGE HIGH

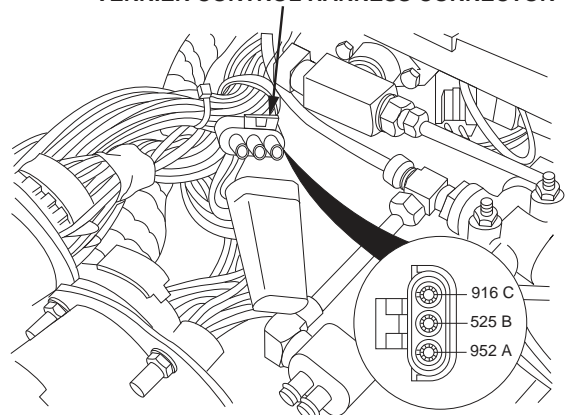


NOTE

The following flow chart should only be used if DDEC troubleshooting was started on p. 2-80 and you were referred here.



VERNIER CONTROL HARNESS CONNECTOR



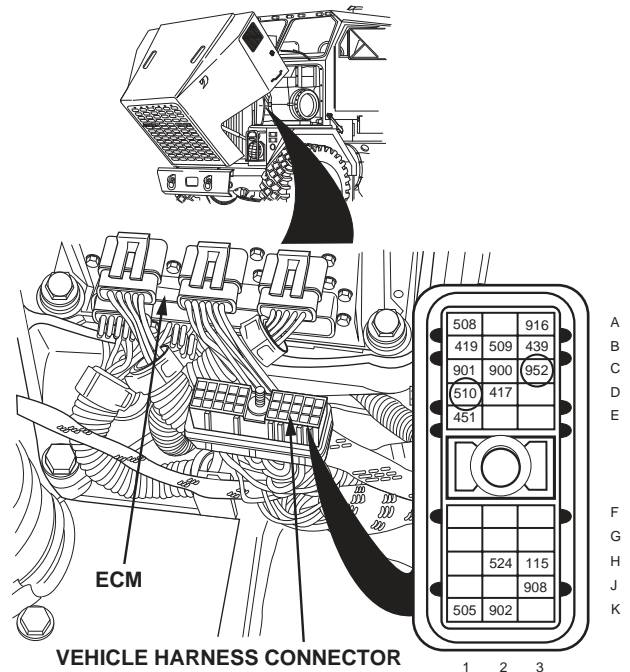
- (1) Turn ENGINE switch OFF and unplug vernier control sensor connector.
- (1.1) Click on "Alarms Clear" to clear alarms screen.
- (2) Turn ENGINE switch ON and read active codes.

CAUTION

Use jumper wire only between terminals indicated. Failure to comply may result in damage to DDEC components or wiring.

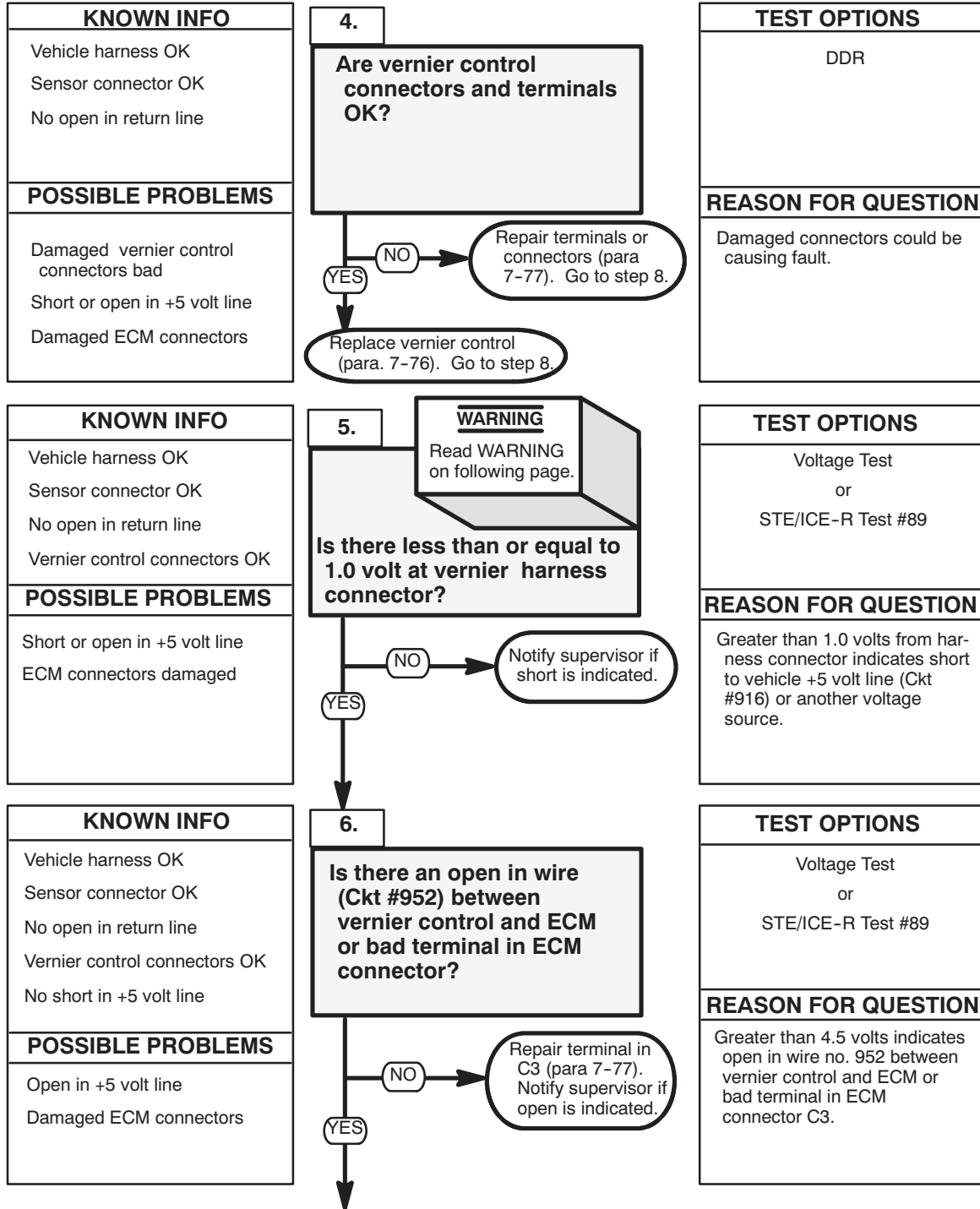
CONTINUITY TEST

- (1) With transmission in neutral, turn ENGINE switch OFF.
- (2) Install a jumper wire between pin A and pin B of vernier control harness connector.
- (3) Disconnect vehicle harness connector at ECM.
- (3.1) Turn engine switch ON.
- (3.2) Push ENGINE SPEED CONTROL switch to ENGINE HIGH IDLE position (TM 9-2320-360-10).
- (3.3) Push and release ENGINE SPEED CONTROL switch forward to engage DDEC HI IDLE relay (TM 9-2320-360-10).
- (4) Read resistance between sockets C3 and D1 on the vehicle harness connector.
- (5) Turn engine switch OFF.



VEHICLE HARNESS CONNECTOR

A4 - CODE 12 VERNIER CONTROL SIGNAL VOLTAGE HIGH (CONT)



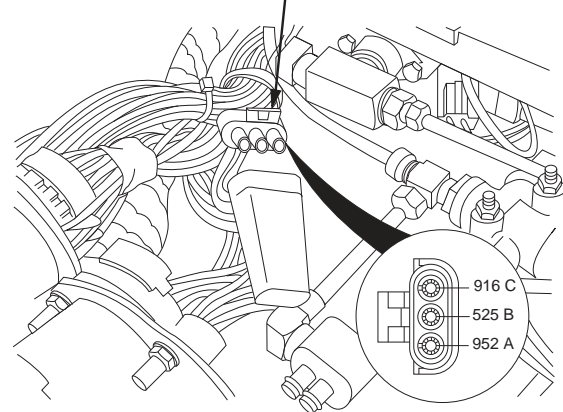
WARNING

Jewelry can catch on equipment and cause injury or short across electrical circuit and cause severe burns or electrical shock. Remove rings, bracelets, watches, necklaces, and any other jewelry before working around HET Tractor.

VOLTAGE TEST

- (1) Connect all connectors to ECM.
- (2) Turn ENGINE switch ON.
- (3) Read voltage from vernier control harness connector pin B (red lead) to pin A (black lead).

VERNIER CONTROL HARNESS CONNECTOR



VOLTAGE TEST

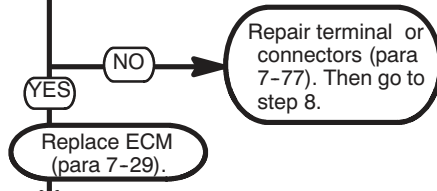
- (1) Connect all connectors to ECM.
- (2) Read voltage on vernier control harness at pin B (red lead) and pin A (black lead) with ENGINE switch ON

A4 - CODE 12 VERNIER CONTROL SIGNAL VOLTAGE HIGH (CONT)

KNOWN INFO
Vehicle harness OK Sensor connector OK No open in return line Vernier control connectors OK No short or open in +5 volt line
POSSIBLE PROBLEMS
Damaged ECM connectors

7.

Are ECM vehicle harness connectors (both ECM and harness side) OK?

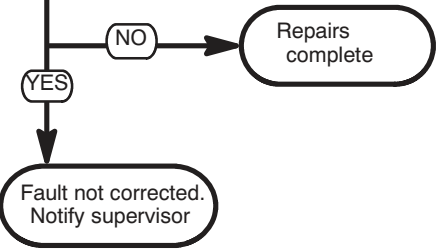


TEST OPTIONS
Visual inspection
REASON FOR QUESTION
Terminal and connectors may be damaged.

KNOWN INFO
Vehicle harness OK Sensor connector OK No open in return line Vernier control connectors OK No short or open in +5 volt line ECM connectors OK
POSSIBLE PROBLEMS
None

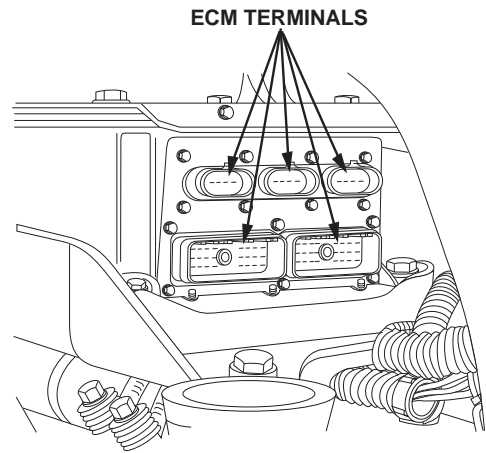
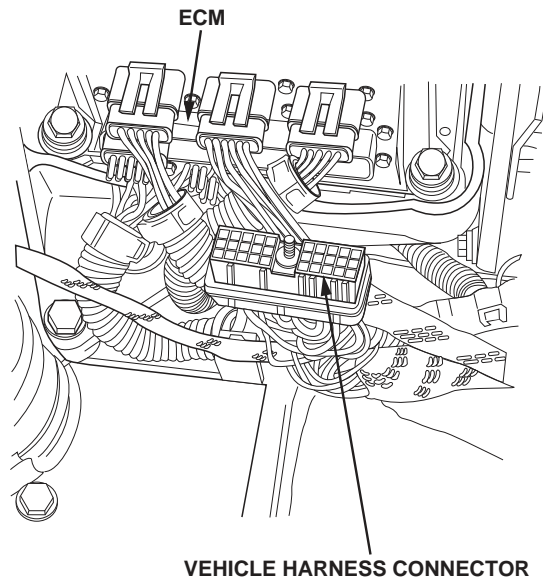
8.

Does CHECK ENGINE indicator light stay on longer than five seconds?

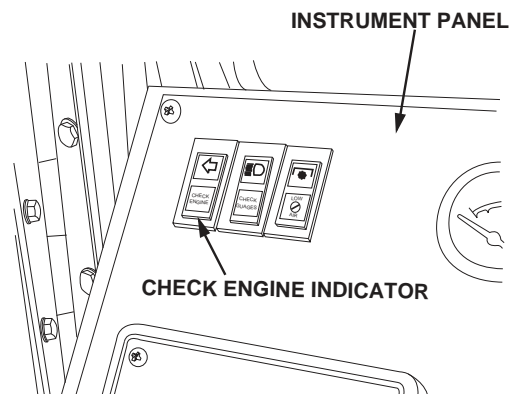


TEST OPTIONS
Visual Inspection
REASON FOR QUESTION
Verify repairs. If CHECK ENGINE indicator lights for approximately five seconds and then goes out after ENGINE switch is turned to ON fault has been corrected.

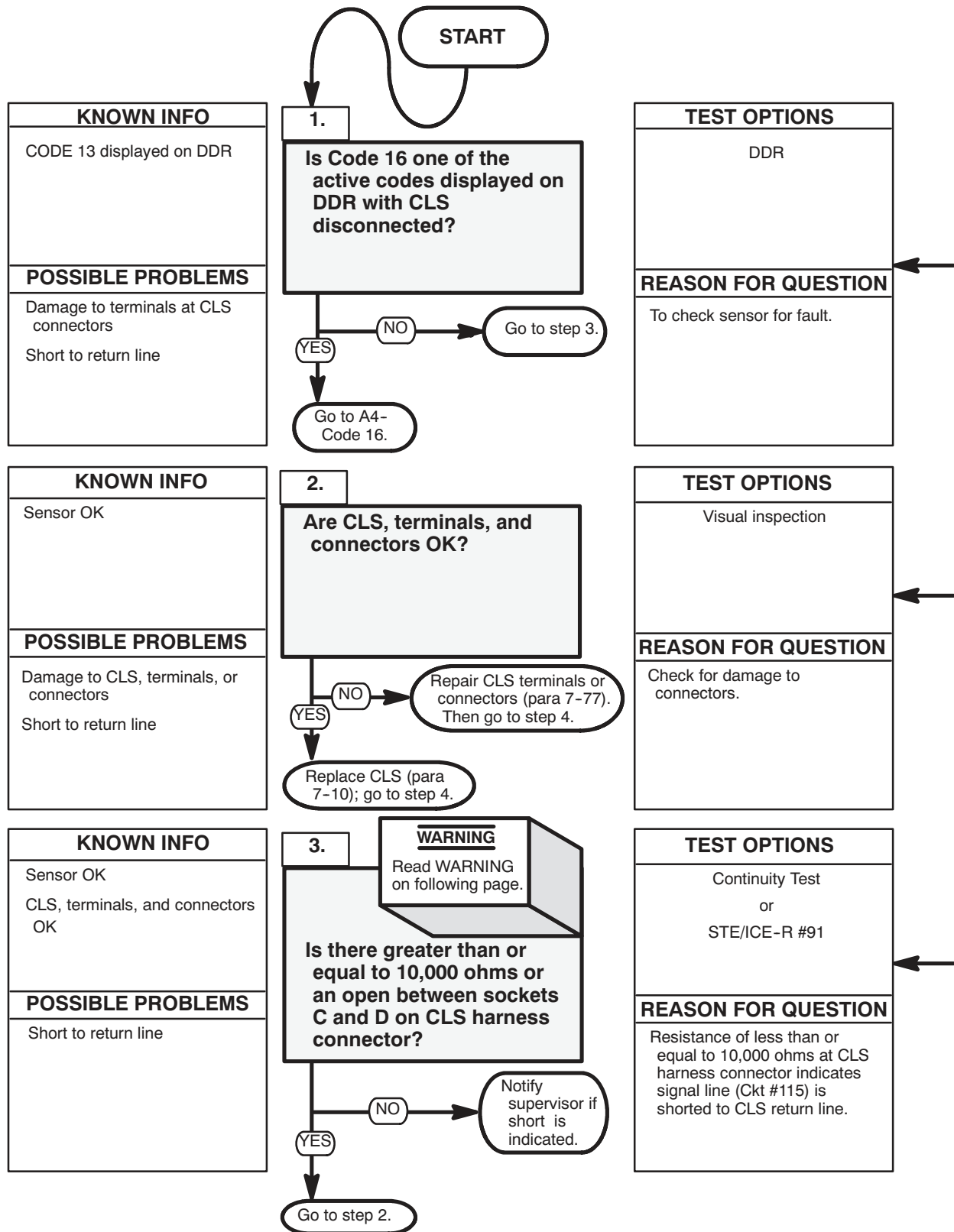




- (1) Turn ENGINE switch OFF.
- (2) Reconnect all harness connectors.
- (3) Turn ENGINE switch ON and observe CHECK ENGINE indicator.



A4 - CODE 13 COOLANT LEVEL SENSOR (CLS) SIGNAL VOLTAGE LOW



NOTE

The following flow chart should only be used if DDEC troubleshooting was started on p. 2-80 and you were referred here.

- (1) Turn ENGINE switch OFF and disconnect CLS.
- (2) Start engine (TM 9-2320-360-10).
- (3) Read active codes.
- (4) Stop engine (TM 9-2320-360-10).

Inspect CLS and terminals at CLS connectors (sensor side and harness side) for damage; bent, corroded, and unseated pins or sockets.

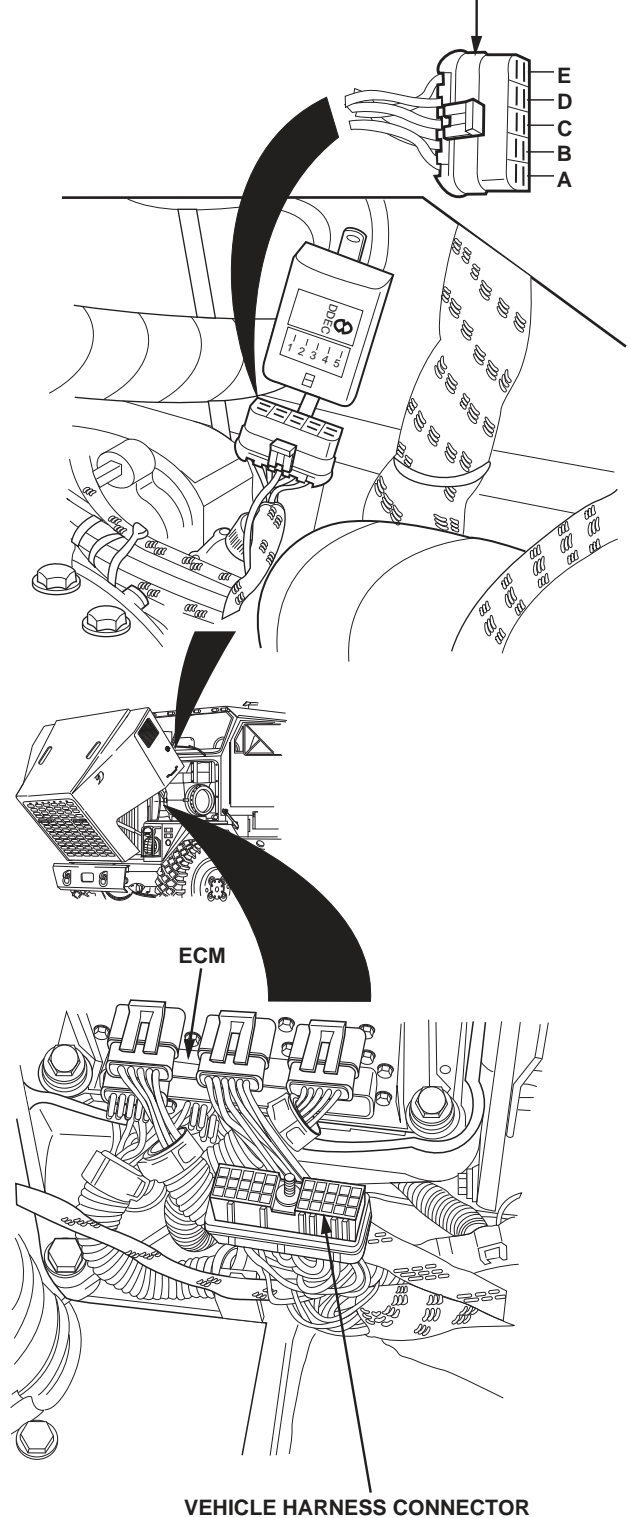
WARNING

- Batteries must be disconnected before tightening any connections. Failure to comply may result in injury to personnel.
- Remove all jewelry such as rings, dog tags, bracelets, etc. If jewelry contacts electrical terminals a direct short may result in an instant heating of tools, damage to equipment, and injury to personnel.

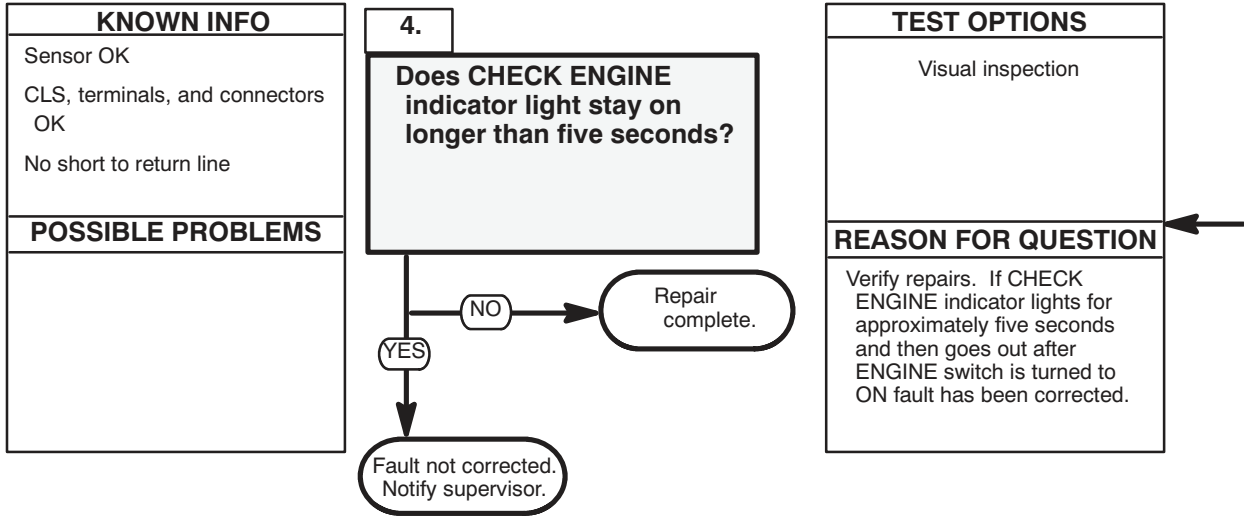
CONTINUITY TEST

- (1) Turn ENGINE switch OFF.
- (2) Disconnect vehicle harness connector at ECM.
- (3) Read resistance between sockets C and D on ECM side of CLS harness connector.

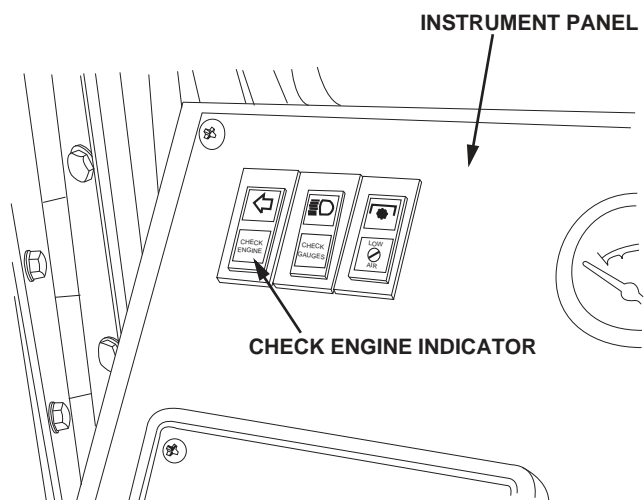
CLS HARNESS CONNECTOR



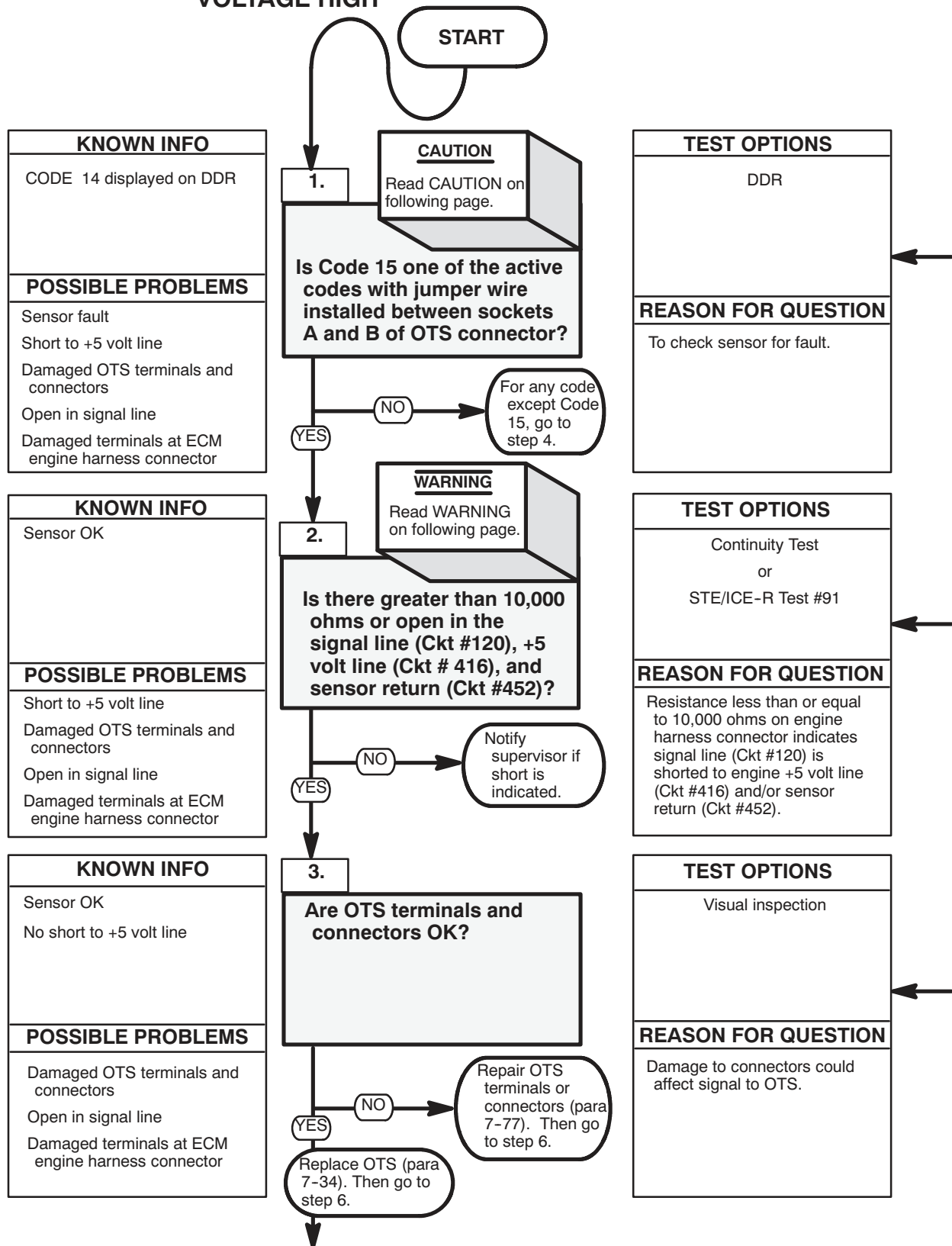
A4 - CODE 13 COOLANT LEVEL SENSOR (CLS) SIGNAL VOLTAGE LOW (CONT)



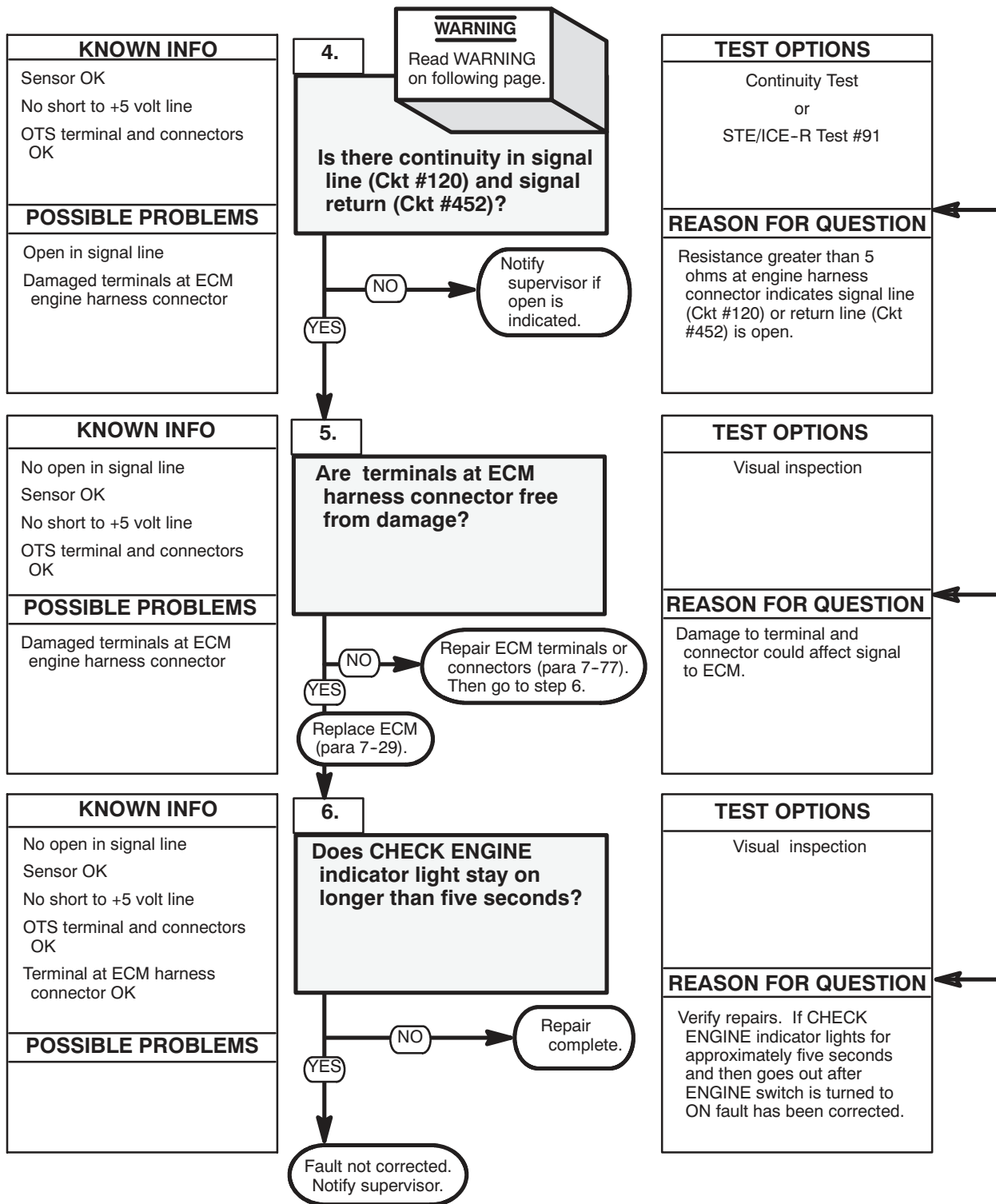
- (1) Turn ENGINE switch OFF.
- (2) Reconnect all harness connectors.
- (3) Turn ENGINE switch ON and observe CHECK ENGINE indicator.



A4 - Code 14 OIL TEMPERATURE SENSOR (OTS) SIGNAL VOLTAGE HIGH



A4 - Code 14 OIL TEMPERATURE SENSOR (OTS) SIGNAL VOLTAGE HIGH (CONT)

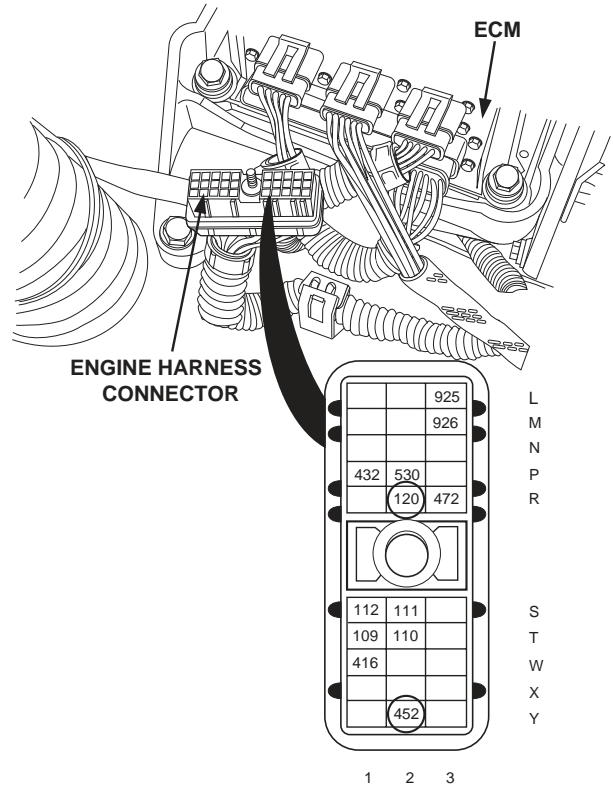


WARNING

- Batteries must be disconnected before tightening any connections. Failure to comply may result in injury to personnel.
- Remove all jewelry such as rings, dog tags, bracelets, etc. If jewelry contacts electrical terminals a direct short may result in an instant heating of tools, damage to equipment, and injury to personnel.

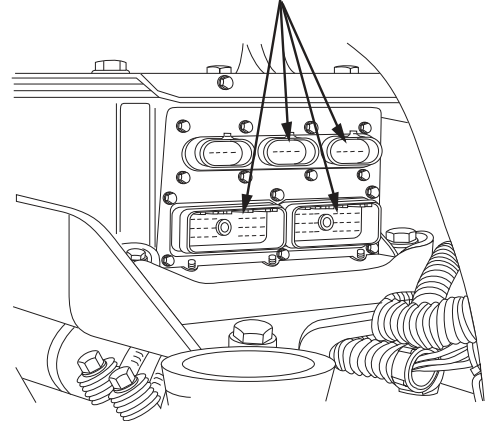
CONTINUITY TEST

- (1) Turn ENGINE switch OFF and disconnect engine harness connector at ECM.
- (2) Read resistance between sockets R2 and Y2 on engine harness connector.



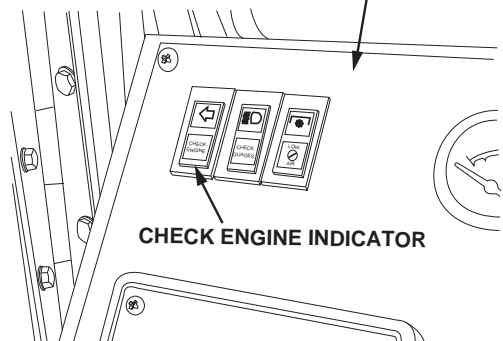
Check terminals at ECM engine harness connector (both ECM and harness side) for damage; bent, corroded, and unseated pins or sockets.

ECM TERMINALS

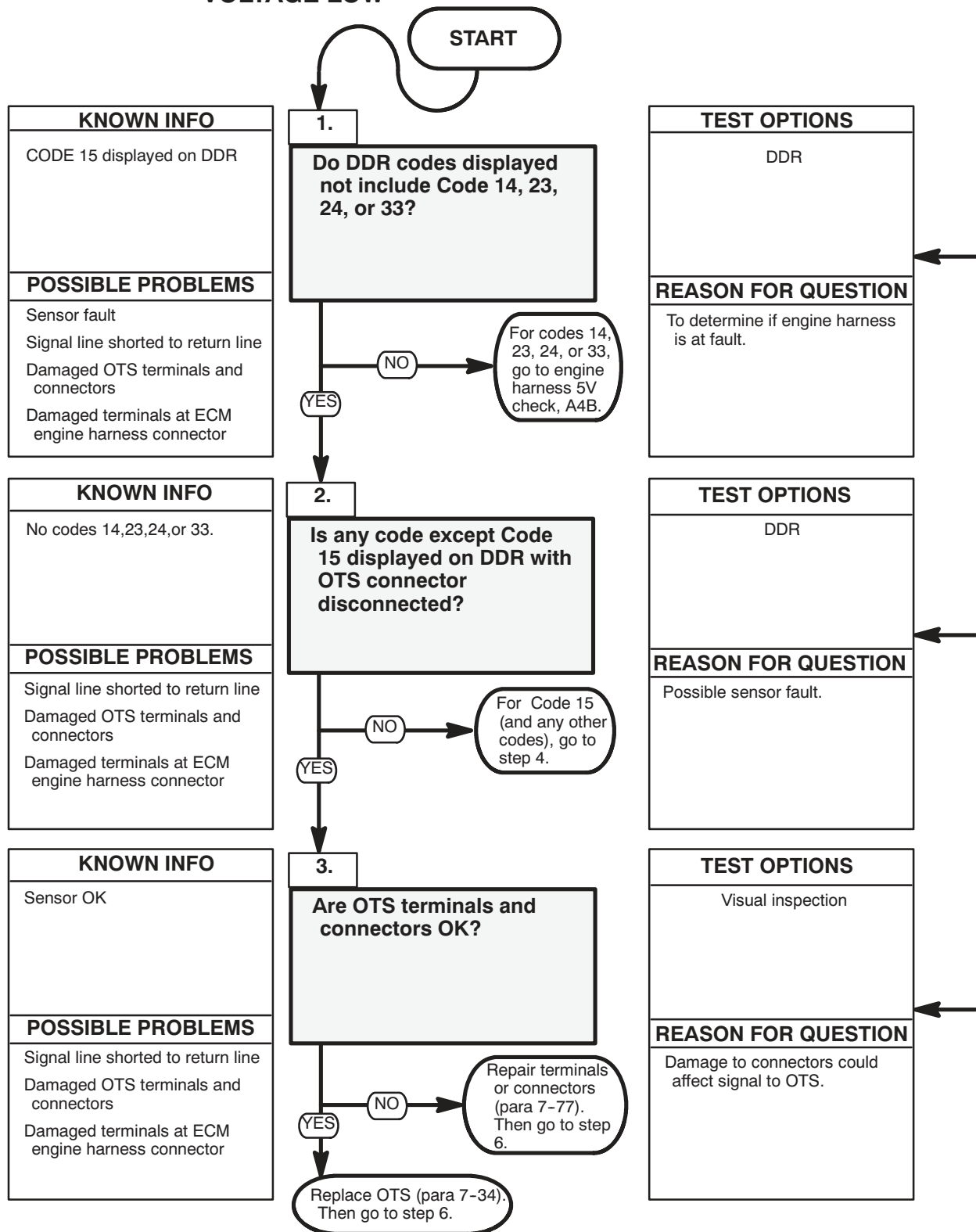


- (1) Turn ENGINE switch OFF.
- (2) Reconnect all harness connectors.
- (3) Turn ENGINE switch ON and observe CHECK ENGINE indicator.

INSTRUMENT PANEL



A4 - Code 15 OIL TEMPERATURE SENSOR (OTS) SIGNAL VOLTAGE LOW

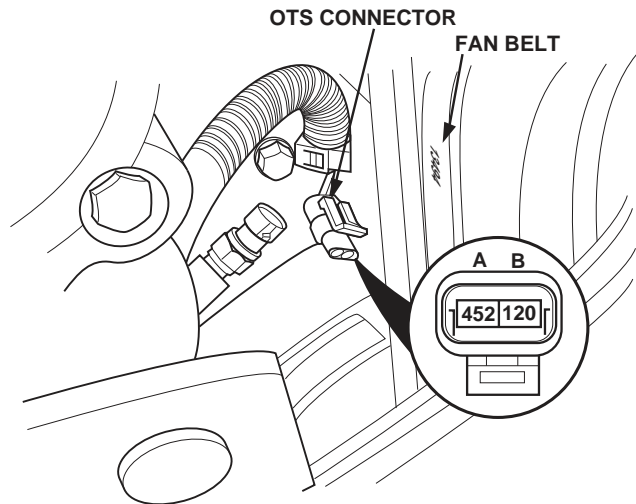


NOTE

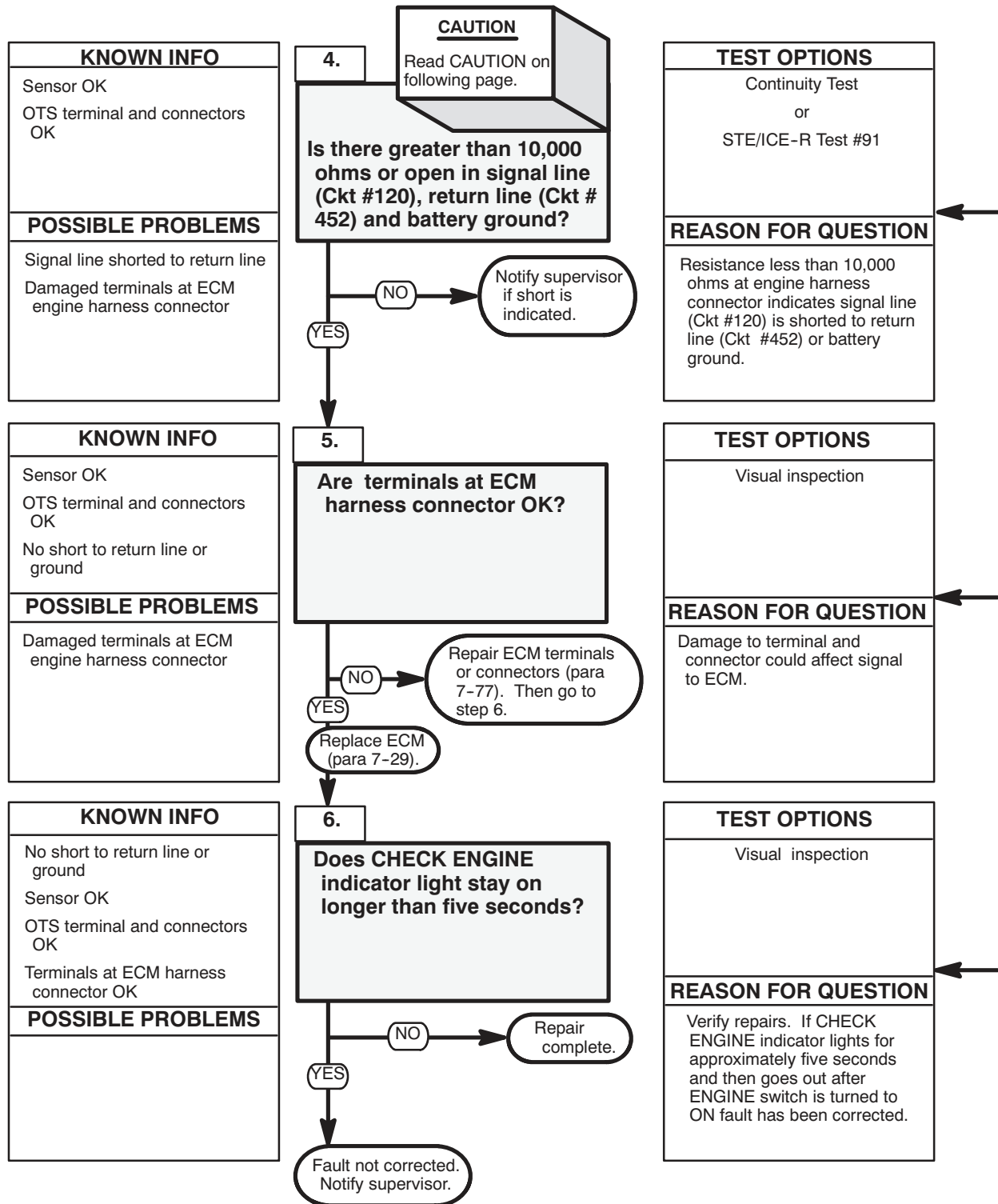
The following flow chart should only be used if DDEC troubleshooting was started on p. 2-80 and you were referred here.

- (1) Turn ENGINE switch OFF and disconnect OTS connector.
- (1.1) Click on "Alarms Clear" to clear alarms screen.
- (2) Start engine and run until CHECK ENGINE light comes on or after 8 minutes.
- (3) Read active codes with engine still running.

Check terminals at OTS connectors (both sensor and harness side) for damage; bent, corroded, and unseated pins or sockets.



A4 - Code 15 OIL TEMPERATURE SENSOR (OTS) SIGNAL VOLTAGE LOW (CONT)



KNOWN INFO
No short to return line or ground Sensor OK OTS terminal and connectors OK Terminals at ECM harness connector OK
POSSIBLE PROBLEMS

6.

Does CHECK ENGINE indicator light stay on longer than five seconds?

NO → Repair complete.

YES → Fault not corrected. Notify supervisor.

TEST OPTIONS
Visual inspection
REASON FOR QUESTION
Verify repairs. If CHECK ENGINE indicator lights for approximately five seconds and then goes out after ENGINE switch is turned to ON fault has been corrected.

CAUTION

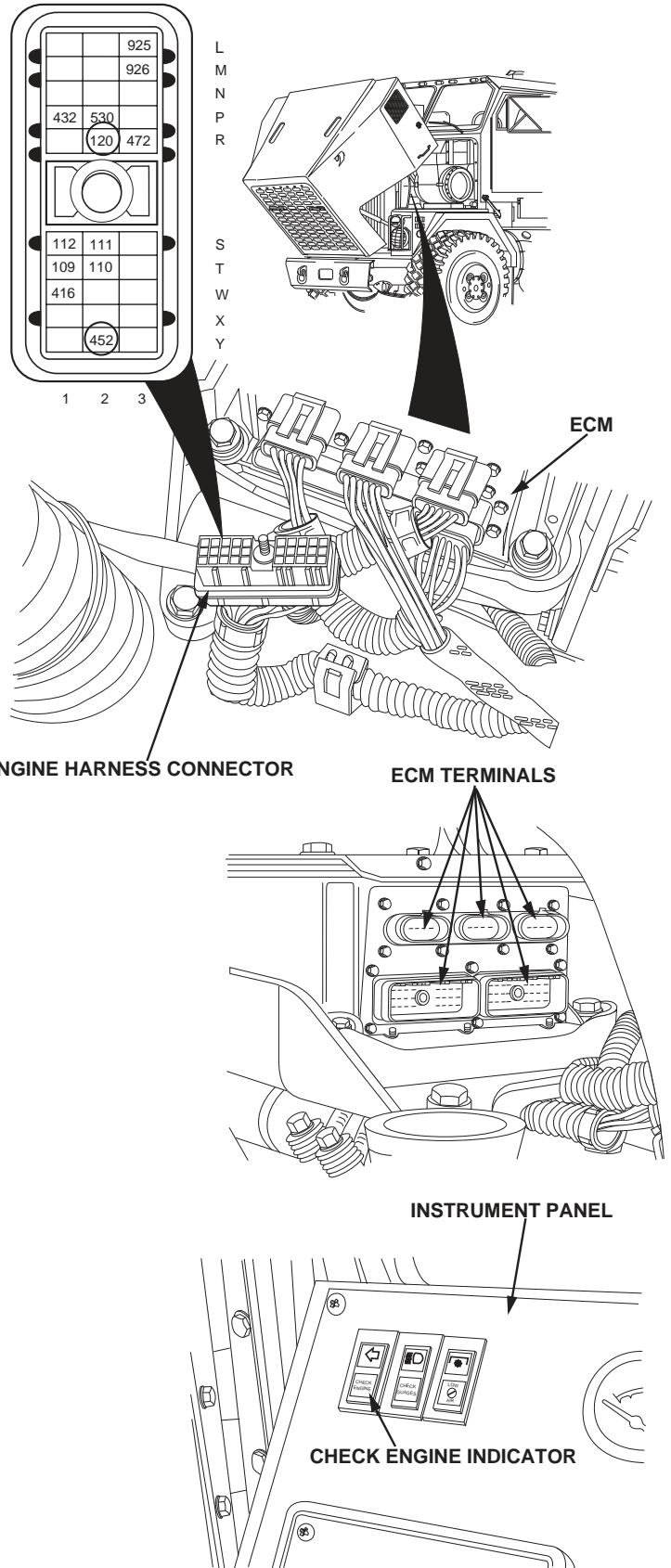
Use jumper wire only between terminals indicated. Failure to comply may result in damage to DDEC components or wiring.

CONTINUITY TEST

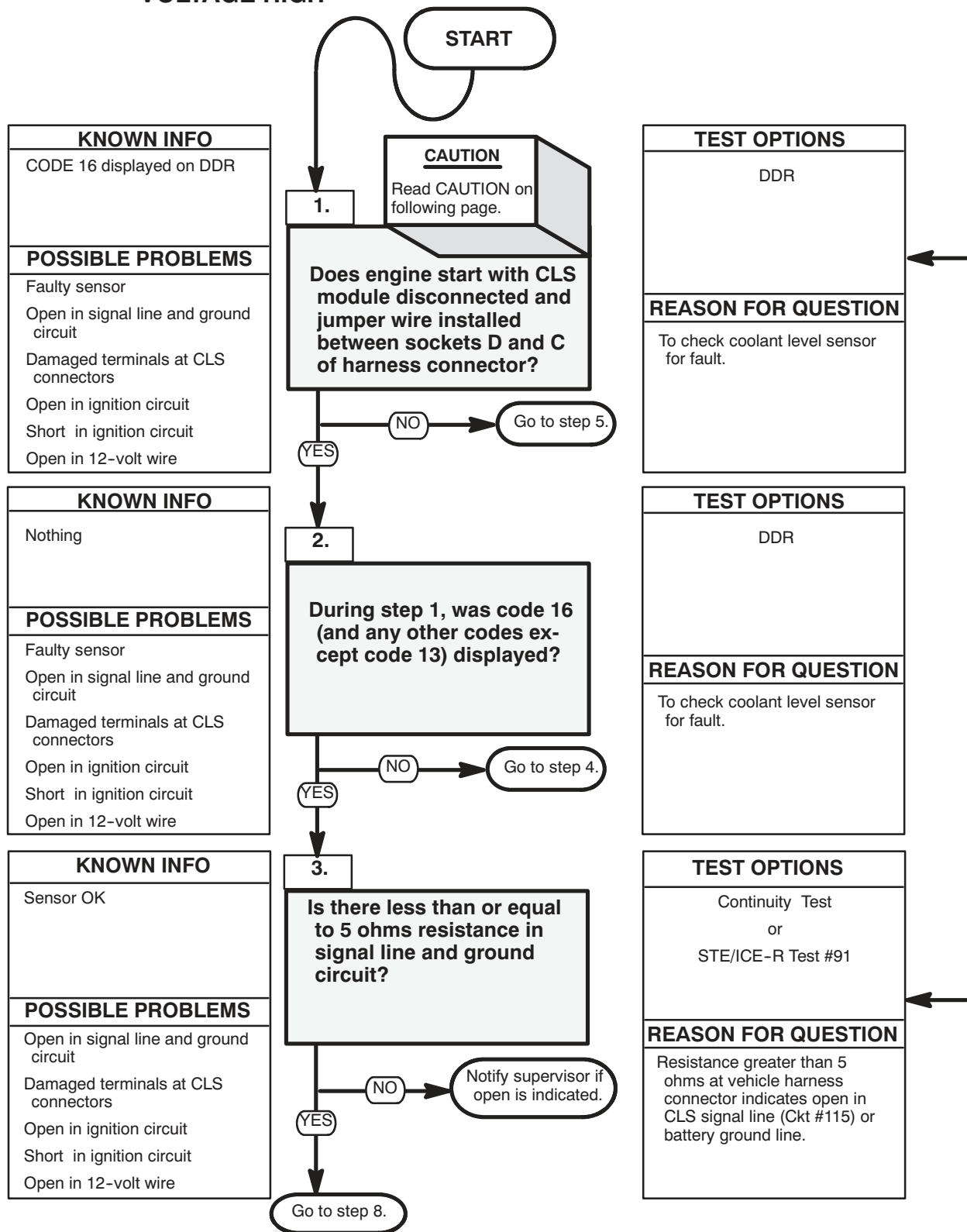
- (1) Turn ENGINE switch OFF and disconnect engine harness connector at ECM.
- (2) Read resistance between sockets R2 and Y2 on engine harness connector. Also read resistance between socket B of OTS connector and a good ground.

Check terminals at ECM engine harness connector (both ECM and harness side) for damage; bent, corroded, and unseated pins or sockets.

- (1) Turn ENGINE switch OFF.
- (2) Reconnect all harness connectors.
- (3) Turn ENGINE switch ON and observe CHECK ENGINE indicator.



A4 - Code 16 TWO PIECE COOLANT LEVEL SENSOR (CLS) SIGNAL VOLTAGE HIGH



CAUTION

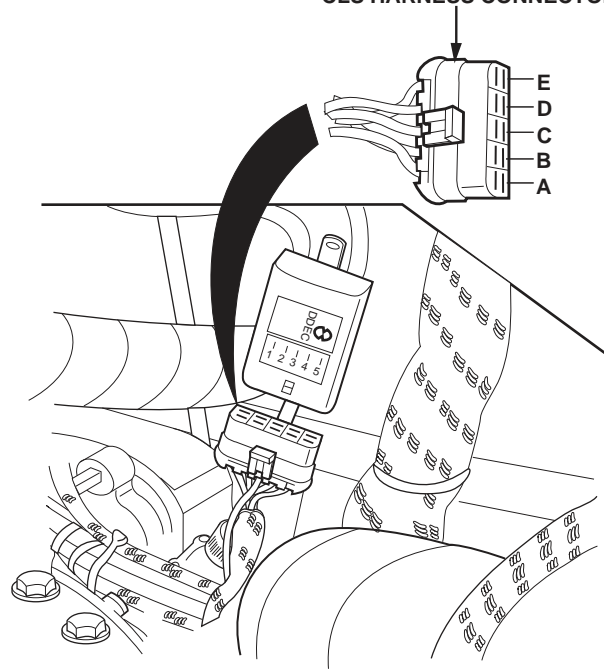
Use jumper wire only between terminals indicated. Failure to comply may result in damage to DDEC components or wiring.

NOTE

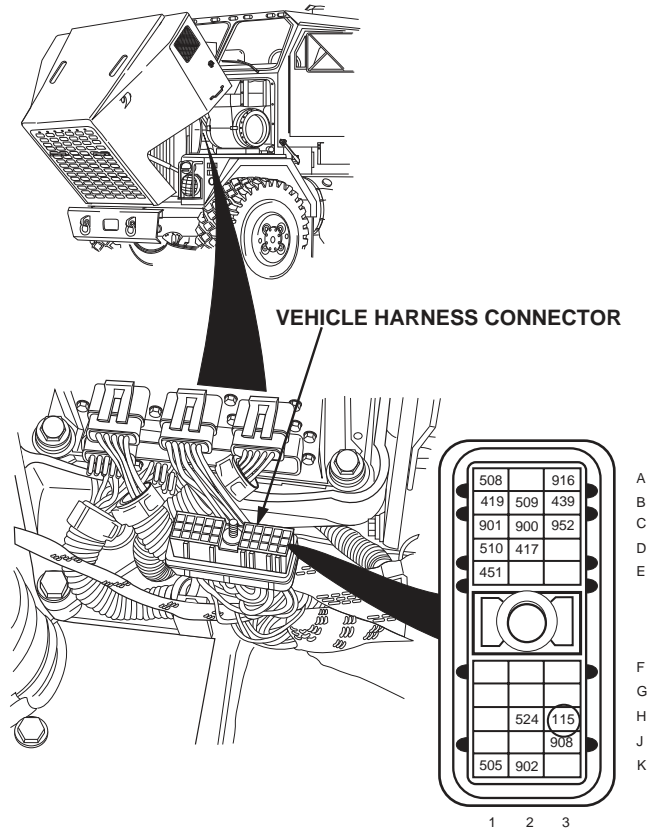
The following flow chart should only be used if DDEC troubleshooting was started on p. 2-82 and you were referred here.

- (4) Turn ENGINE switch OFF.
- (5) Disconnect CLS module and install a jumper between sockets D and C of CLS harness connector.
- (6) Attempt to start and run engine at idle.
- (7) Read active codes.
- (8) Stop engine.

CLS HARNESS CONNECTOR



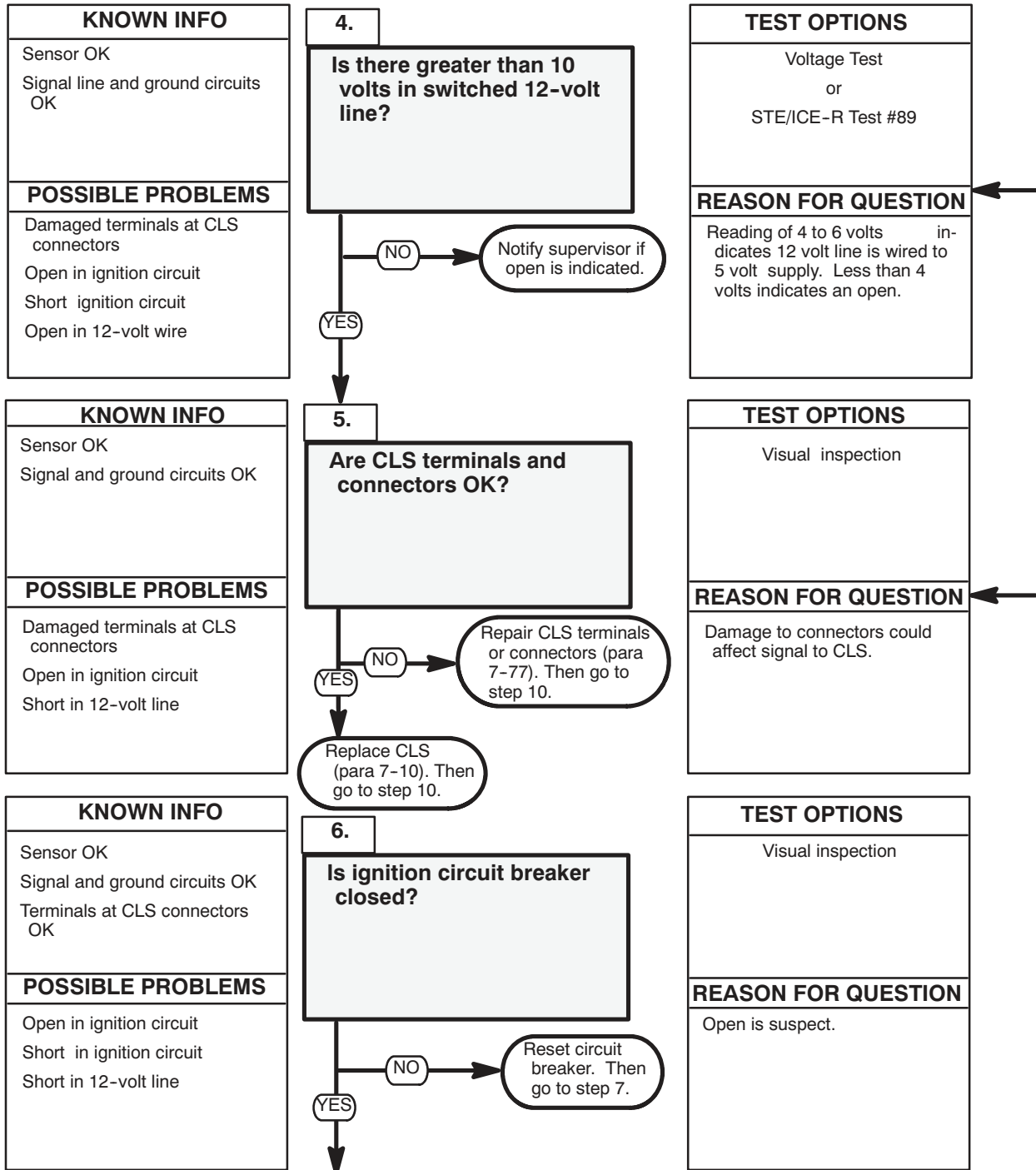
VEHICLE HARNESS CONNECTOR



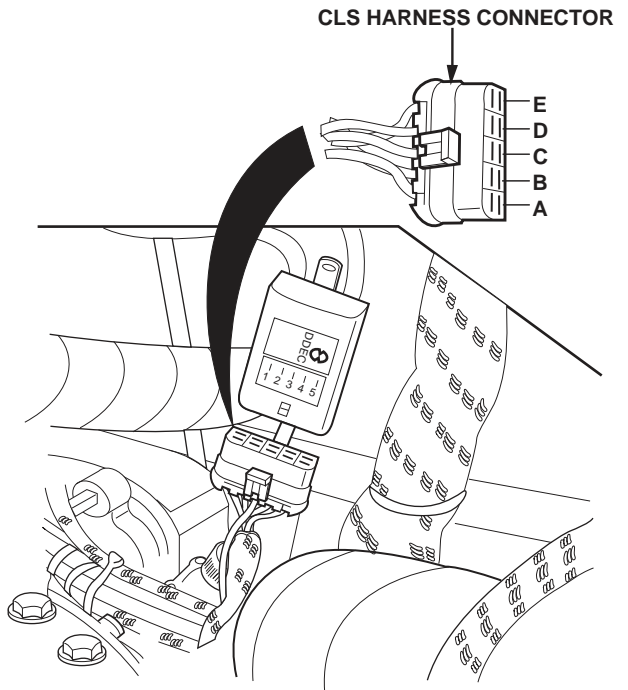
CONTINUITY TEST

- (1) Turn ENGINE switch OFF and disconnect vehicle harness connector.
- (2) Read resistance between socket H3 on vehicle harness connector and a good ground.

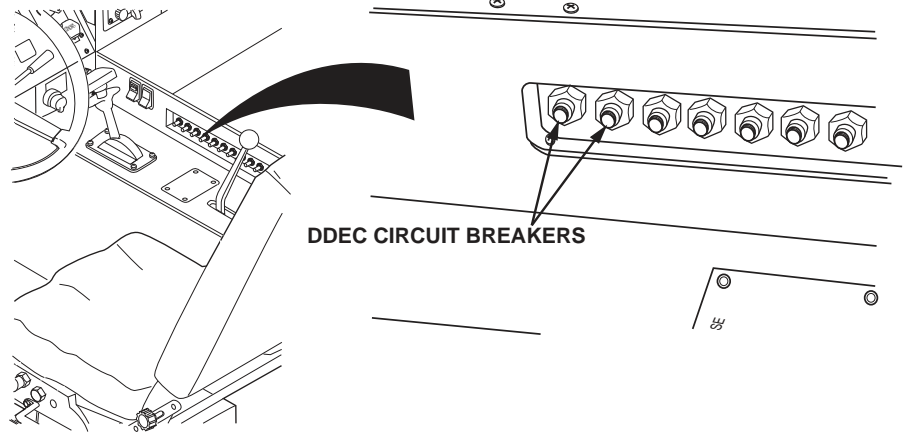
A4 - Code 16 TWO PIECE COOLANT LEVEL SENSOR (CLS) SIGNAL VOLTAGE HIGH (CONT)



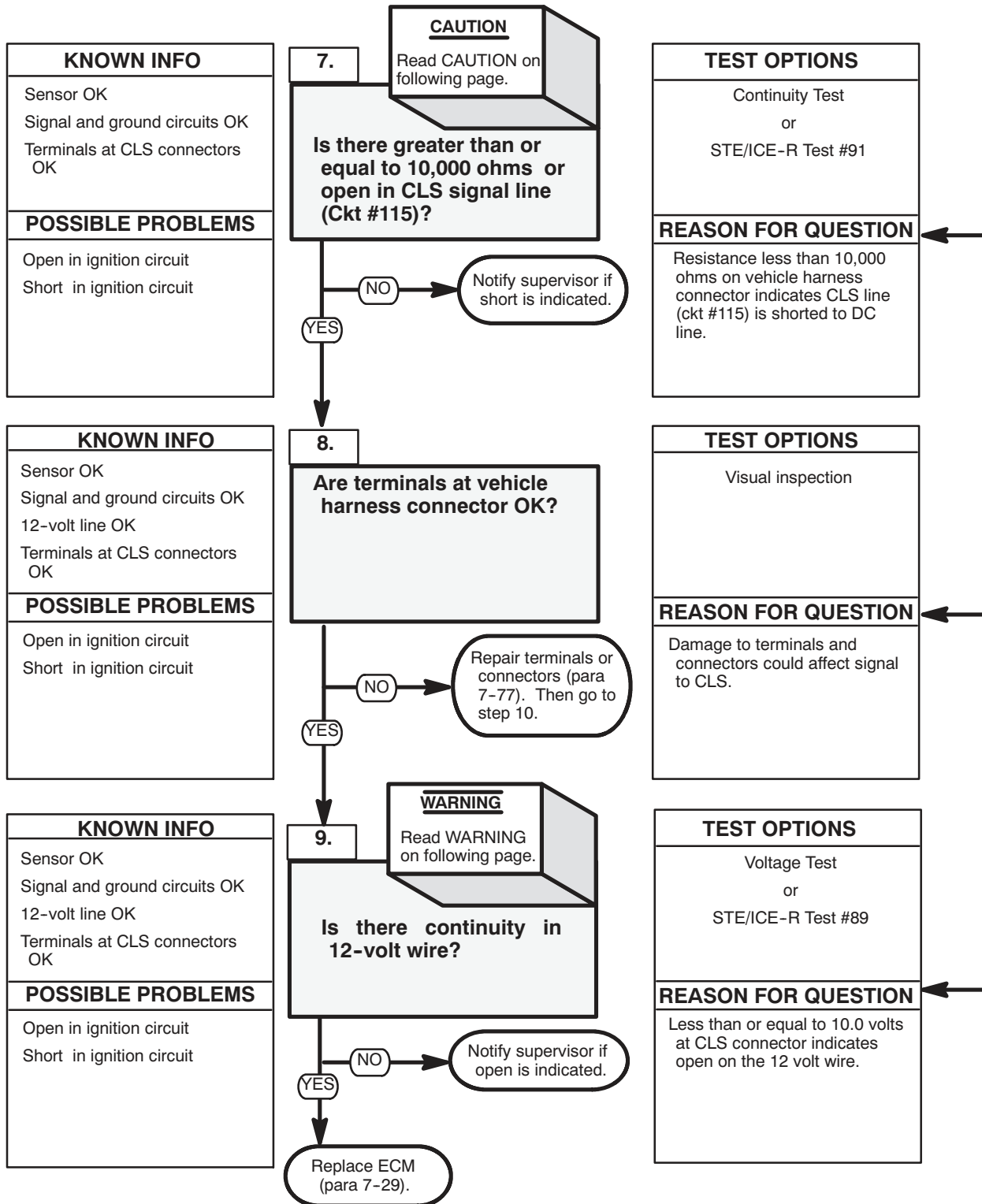
VOLTAGE TEST
 (1) Remove jumper wire.
 (2) Turn ENGINE switch ON and read voltage at CLS connector, socket E (red lead) to socket C (black lead).



Inspect CLS and terminals at CLS connectors (sensor and harness side) for damage; bent, corroded, and unseated pins or sockets.



A4 - Code 16 TWO PIECE COOLANT LEVEL SENSOR (CLS) SIGNAL VOLTAGE HIGH (CONT)



CAUTION

Use jumper wire only between terminals indicated. Failure to comply may result in damage to DDEC components or wiring.

CONTINUITY TEST

- (1) Disconnect vehicle harness connector at ECM
- (2) Remove jumper at CLS harness connector
- (3) Read resistance between sockets D and E of CLS connector on vehicle harness.

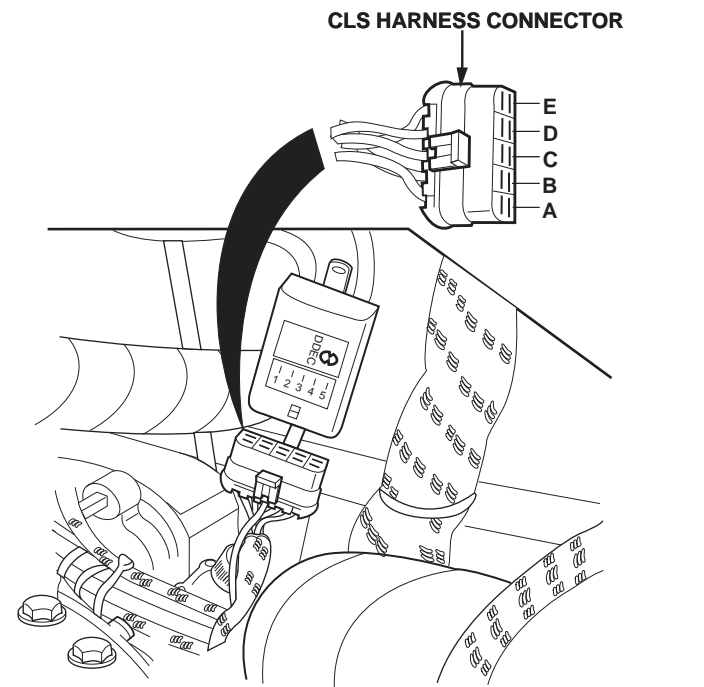
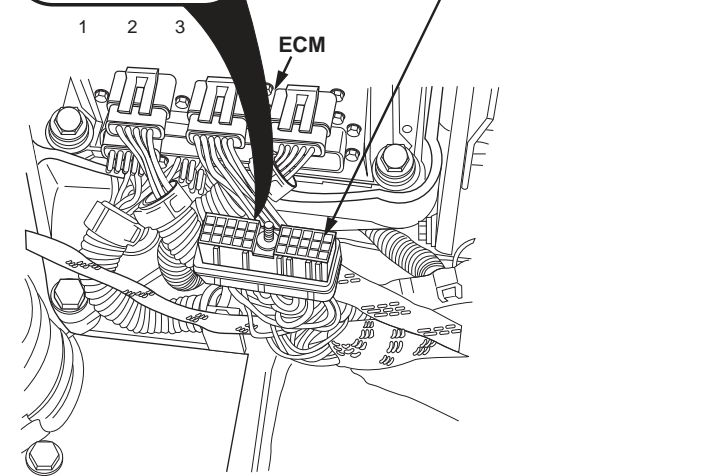
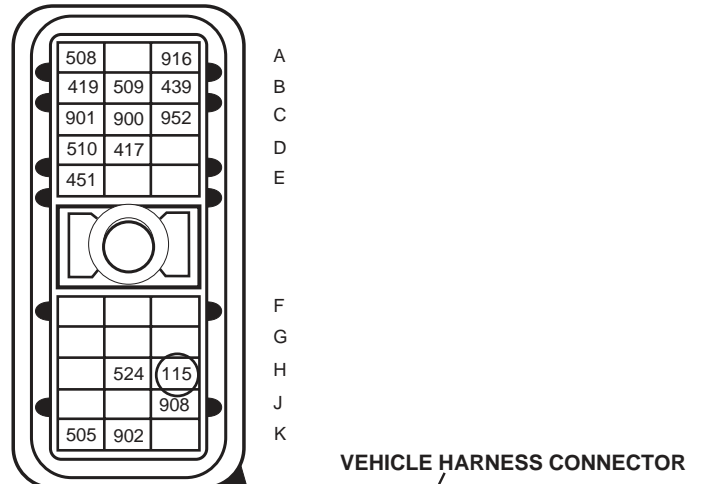
- (1) Check terminals at vehicle harness connector (both ECM and harness side) for damage; bent, corroded, and unseated pins or sockets.
- (2) Check terminal and pin H3 at ECM and all terminals and pins in CLS module connectors for damage; bent, corroded, and unseated pins or sockets.

WARNING

Jewelry can catch on equipment and cause injury or short across electrical circuit and cause severe burns or electrical shock. Remove rings, bracelets, watches, necklaces, and any other jewelry before working around HET Tractor.

VOLTAGE TEST

- (1) Turn ENGINE switch OFF and disconnect CLS module connector.
- (2) Place red lead of a voltmeter into terminal E of CLS connector vehicle harness side.
- (3) Connect black lead to terminal C of CLS connector vehicle harness side
- (4) Turn ENGINE switch ON and read voltage.

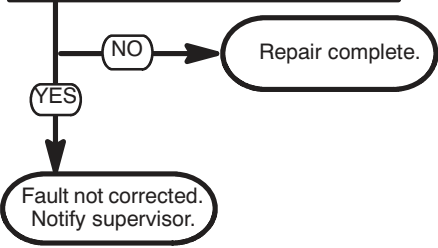


A4 - Code 16 TWO PIECE COOLANT LEVEL SENSOR (CLS) SIGNAL VOLTAGE HIGH (CONT)

KNOWN INFO
Sensor OK
Signal and ground circuits OK
12-volt line OK
Terminals at CLS connectors OK
Ignition circuit OK
POSSIBLE PROBLEMS

10.

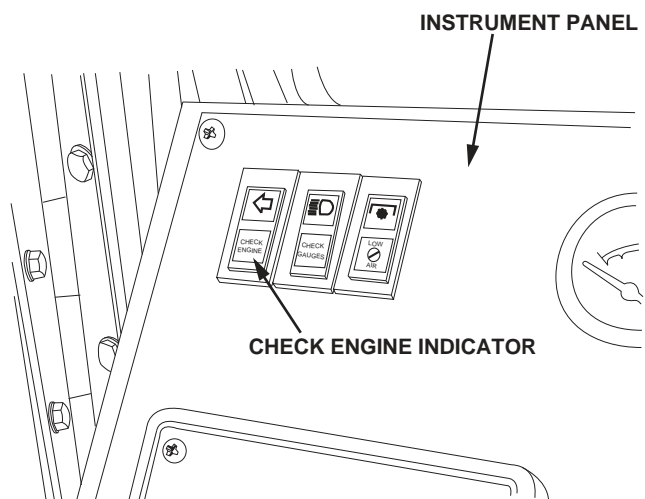
Does CHECK ENGINE indicator light stay on longer than five seconds?



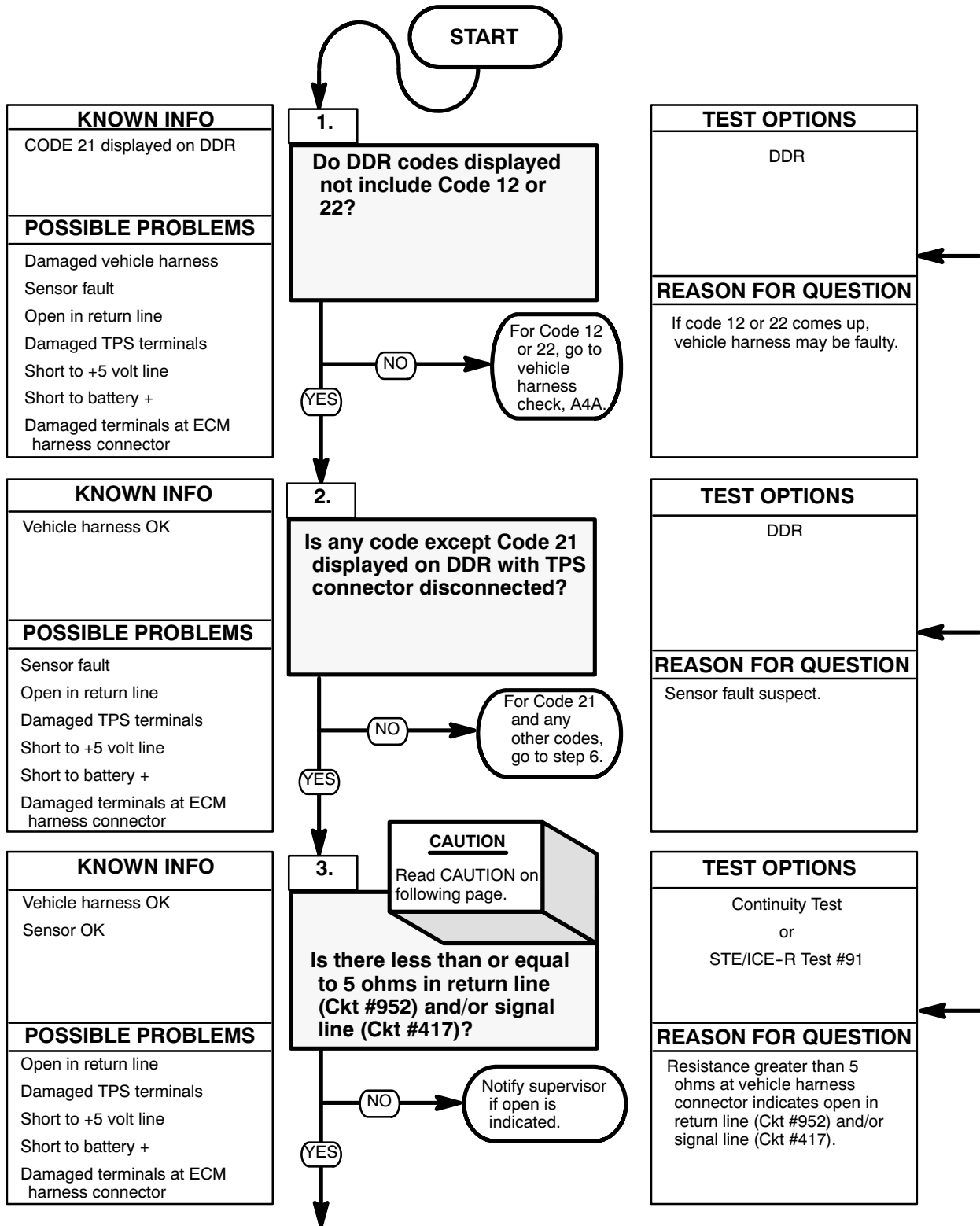
TEST OPTIONS
Visual Inspection
REASON FOR QUESTION
If CHECK ENGINE indicator lights for approximately five seconds and then goes out after ENGINE switch is turned to ON, fault has been corrected.



- (1) Turn ENGINE switch OFF.
- (2) Reconnect all harness connectors.
- (3) Turn ENGINE switch ON and observe CHECK ENGINE indicator.



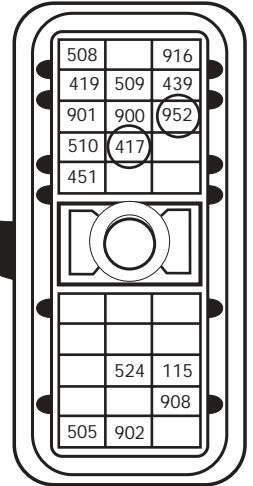
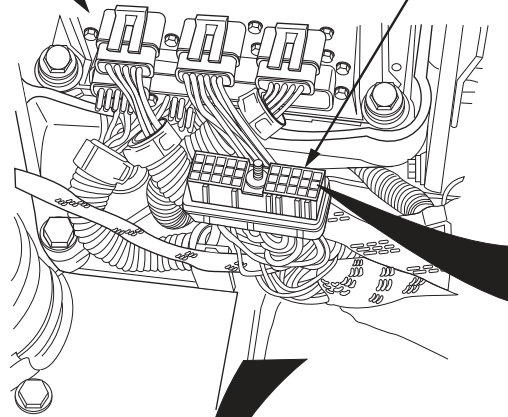
A4 - Code 21 THROTTLE POSITION SENSOR (TPS) SIGNAL VOLTAGE HIGH



ECM VEHICLE HARNESS CONNECTOR

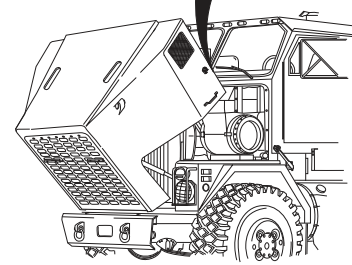
NOTE

The following flow chart should only be used if DDEC troubleshooting was started on p. 2-80 and you were referred here.



A
B
C
D
E
F
G
H
J
K

- (1) Turn ENGINE switch OFF and disconnect TPS connector.
- (1.1) Click on "Alarms Clear" to clear alarms screen.
- (2) Turn ENGINE switch ON and read active codes.



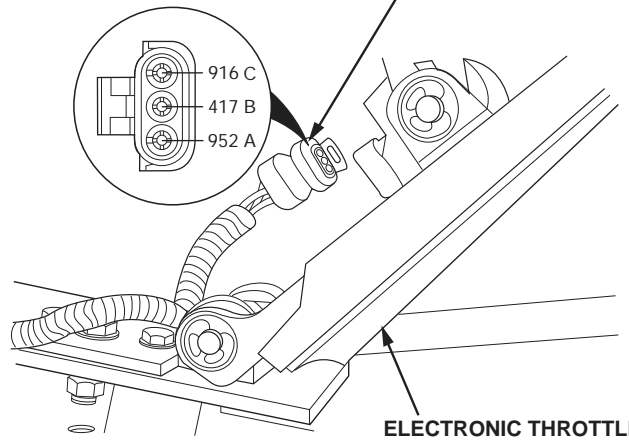
CAUTION

Use jumper wire only between terminals indicated. Failure to comply may result in damage to DDEC components or wiring.

CONTINUITY TEST

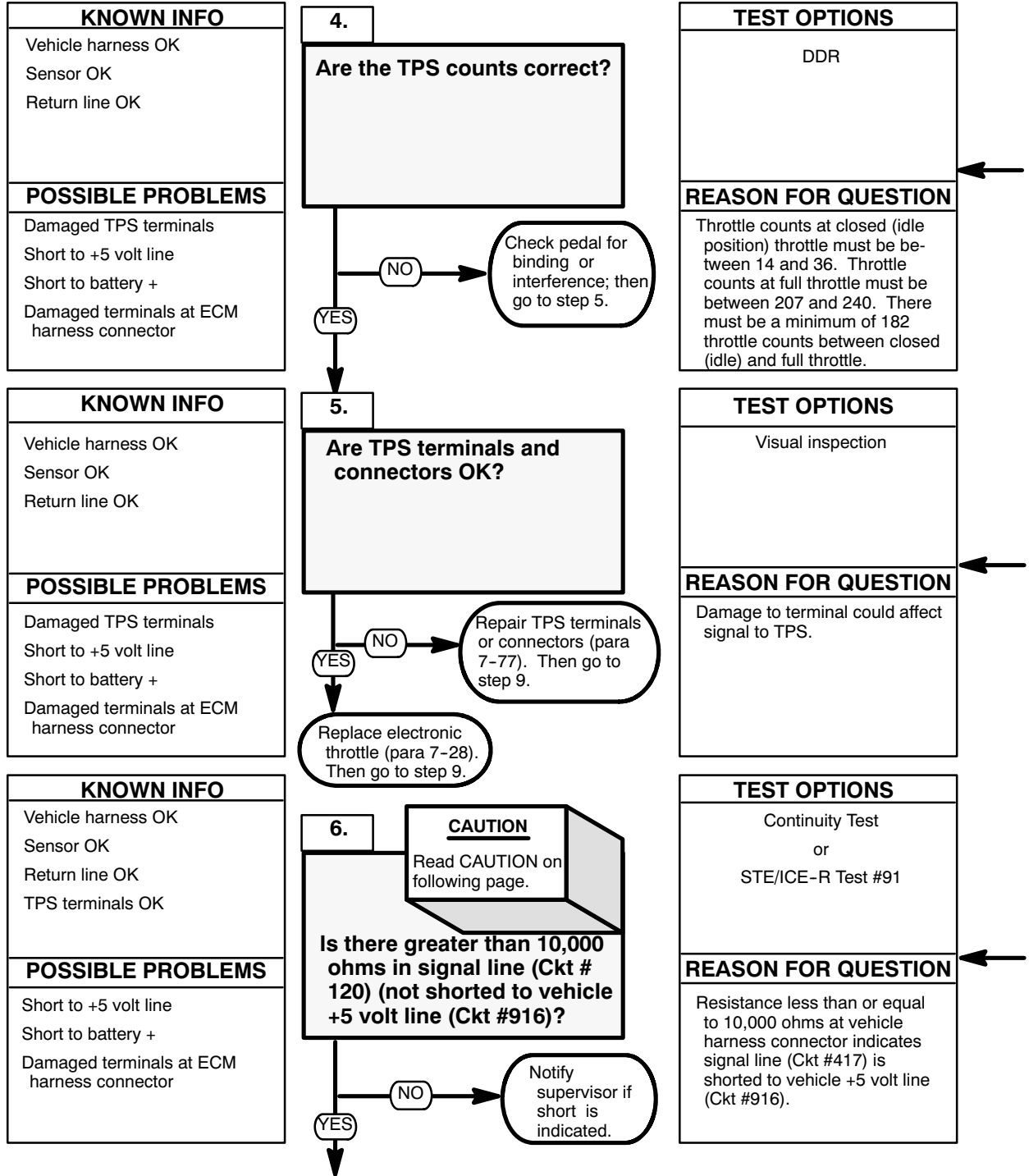
- (1) Turn ENGINE switch OFF.
- (2) Install a jumper wire between pins A and B of TPS harness connector at ECM.
- (3) Read resistance between sockets D2 and C3 on vehicle harness connector.

TPS HARNESS CONNECTOR



ELECTRONIC THROTTLE

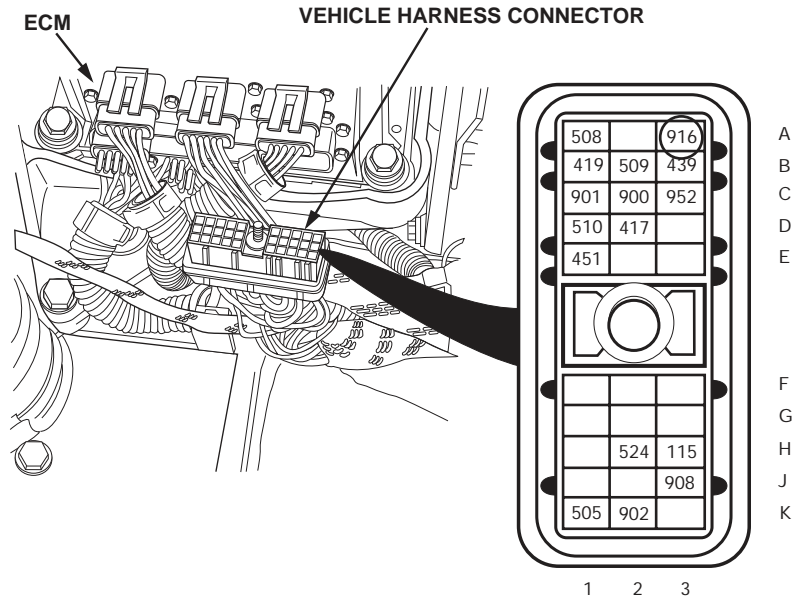
A4 - Code 21 THROTTLE POSITION SENSOR (TPS) SIGNAL VOLTAGE HIGH (CONT)



CAUTION

Never attempt to adjust the electronic throttle by bending the pedal mechanism. Bending can cause internal linkages to bind or extend motion beyond the built-in pedal stops.

- (1) Reconnect vehicle harness connector and plug TPS back in.
- (2) Hook up DDR to 12-pin DDL connector and select Throttle Sensor Display.
- (3) Read throttle counts at both no throttle and at full throttle



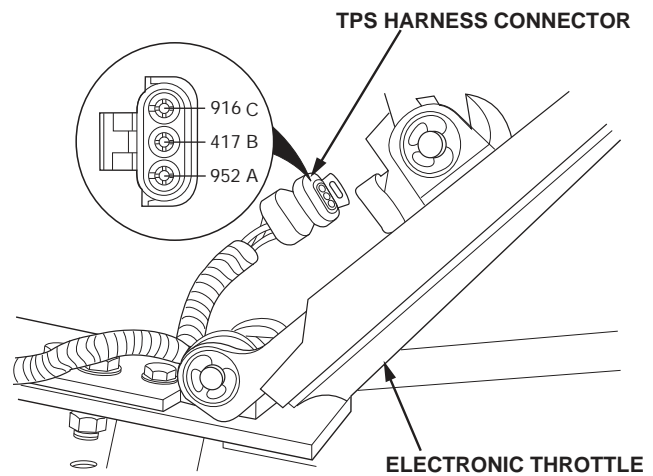
Inspect TPS and terminals at TPS connectors (sensor side and harness side) for damage; bent, corroded, and unseated pins or sockets.

CAUTION

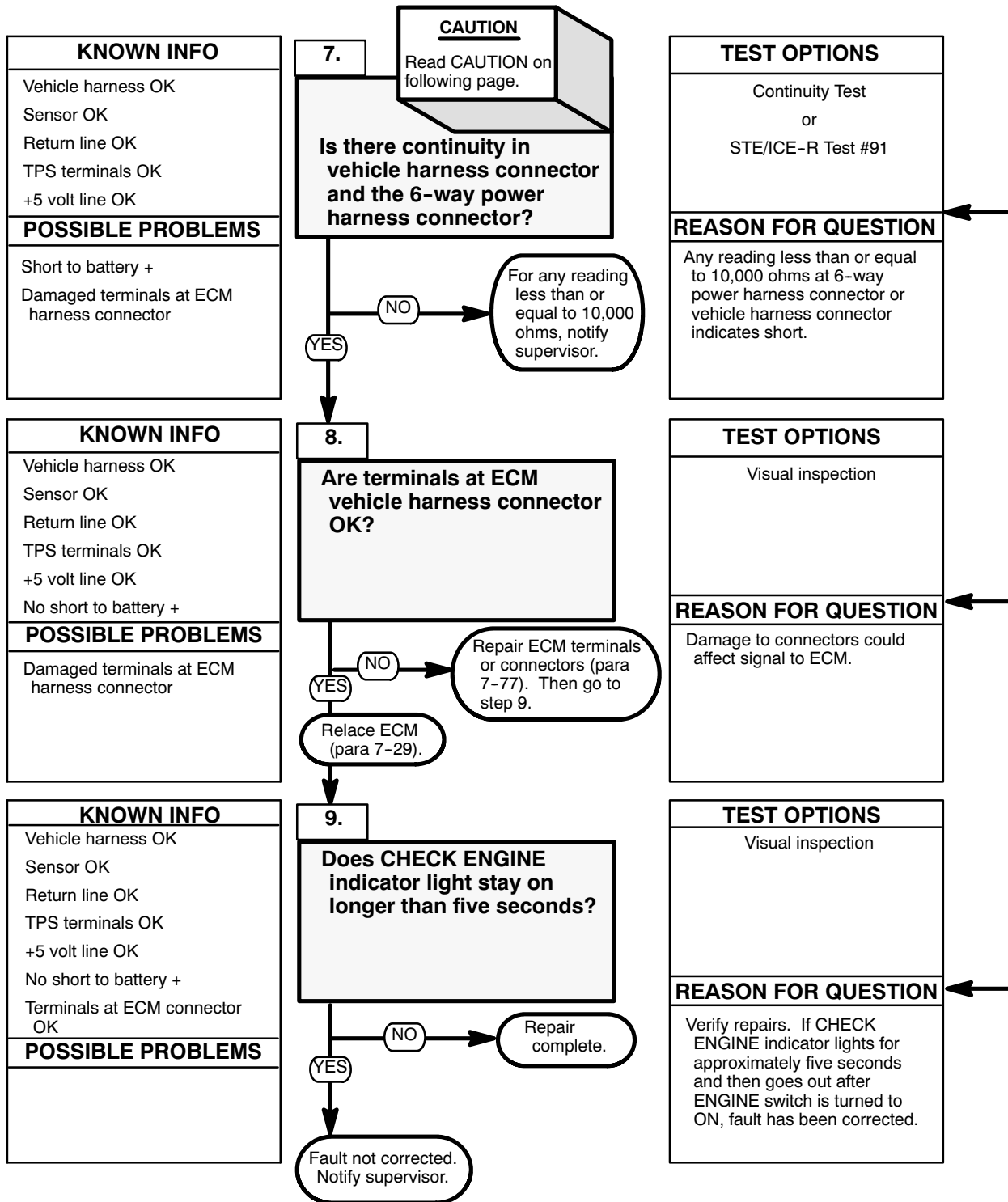
Use jumper wire only between terminals indicated. Failure to comply may result in damage to DDEC components or wiring.

CONTINUITY TEST

- (1) Turn ENGINE switch OFF and disconnect vehicle harness connector at ECM.
- (2) Read resistance between sockets D2 and A3 on vehicle harness connector.



A4 - Code 21 THROTTLE POSITION SENSOR (TPS) SIGNAL VOLTAGE HIGH (CONT)



CAUTION

Use jumper wire only between terminals indicated. Failure to comply may result in damage to DDEC components or wiring.

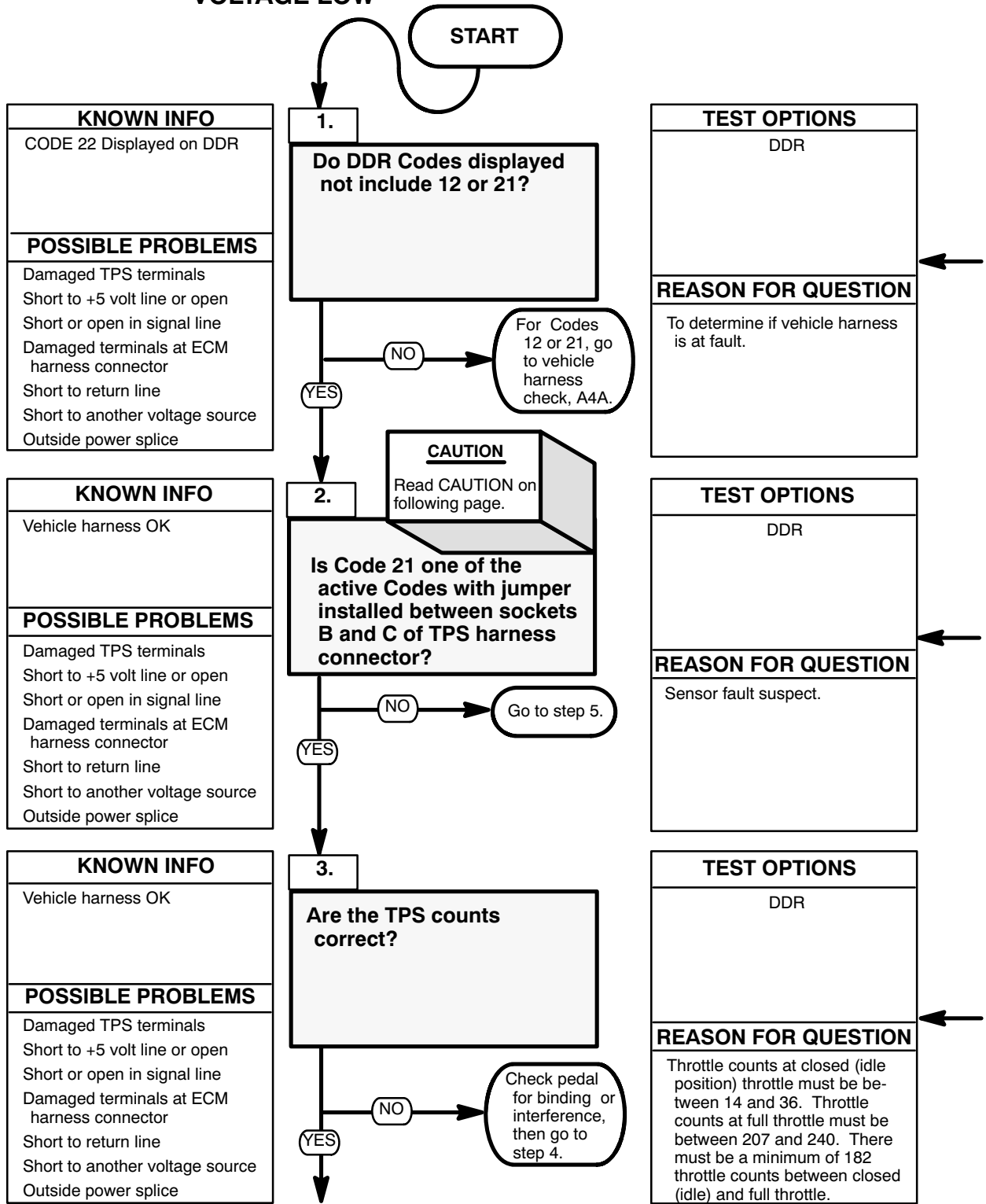
CONTINUITY TEST

- (1) Disconnect batteries (para 7-61).
- (2) Disconnect vehicle harness and 6-way power harness connectors at ECM.
- (3) Read resistance between sockets D2 and B3 of vehicle harness connector.
- (4) Read resistance between socket D2 on vehicle harness connector and sockets A, B, E, and F on 6-way power harness connector.
- (5) Connect batteries (para 7-61).

Check terminals at ECM vehicle harness connector (both ECM and harness side) for damage; bent, corroded, and unseated pins and sockets.

- (1) Turn ENGINE switch OFF.
- (2) Reconnect all harness connectors.
- (3) Turn ENGINE switch ON and observe CHECK ENGINE indicator.

A4 - Code 22 THROTTLE POSITION SENSOR (TPS) SIGNAL VOLTAGE LOW



NOTE

The following flow chart should only be used if DDEC troubleshooting was started on p. 2-80 and you were referred here.

CAUTION

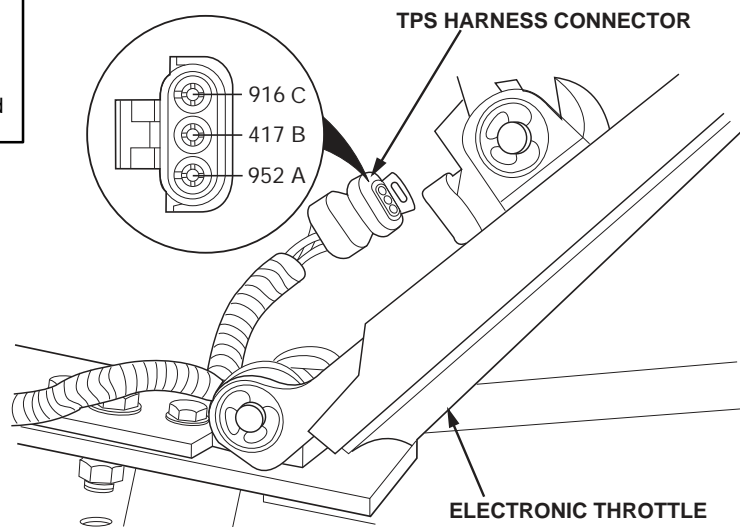
Use jumper wire only between terminals indicated. Failure to comply may result in damage to DDEC components or wiring.

- (1) Turn ENGINE switch OFF and disconnect TPS connector.
- (2) Install a jumper wire between sockets B and C of TPS harness connector.
- (3) Click on "Alarms Clear" to clear alarms screen.
- (4) Turn ENGINE switch ON and read active codes.

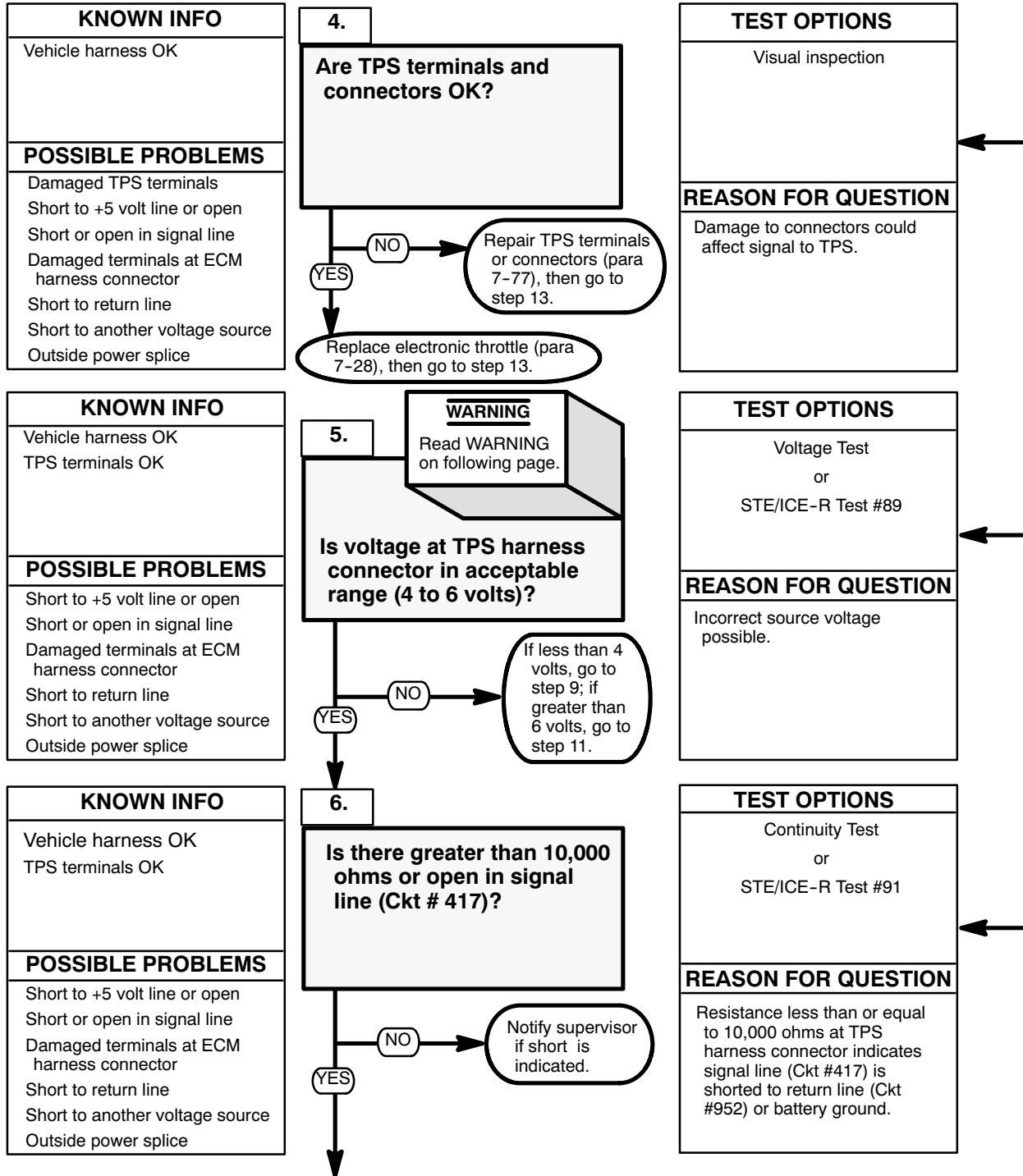
CAUTION

Never attempt to adjust the electronic throttle by bending the pedal mechanism. Bending can cause internal linkages to bind or extend motion beyond the built-in pedal stops.

- (1) Remove jumper and reconnect TPS.
- (2) Hook up DDR to 12-pin DDL connector and select throttle sensor display.
- (3) Read throttle counts at both no throttle and full throttle.



A4 - Code 22 THROTTLE POSITION SENSOR (TPS) SIGNAL VOLTAGE LOW (CONT)



Inspect TPS and terminals at TPS connectors (sensor side and harness side) for damage; bent, corroded, and unseated pins or sockets.

WARNING

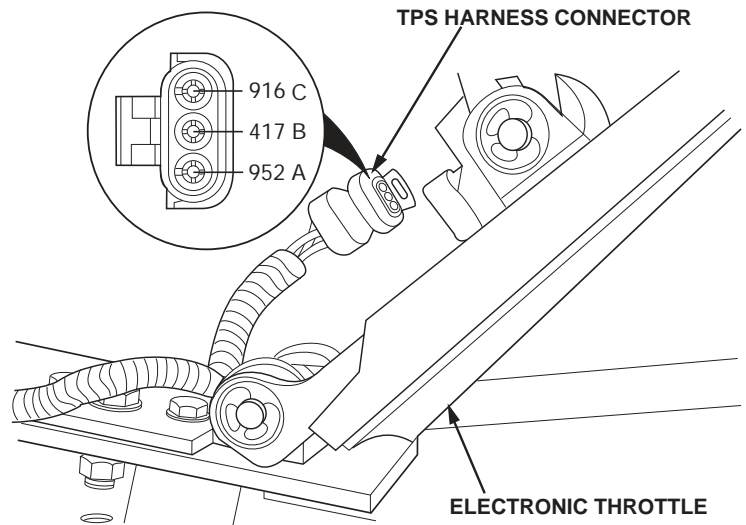
Jewelry can catch on equipment and cause injury or short across electrical circuit and cause severe burns or electrical shock. Remove rings, bracelets, watches, necklaces, and any other jewelry before working around HET Tractor.

VOLTAGE TEST

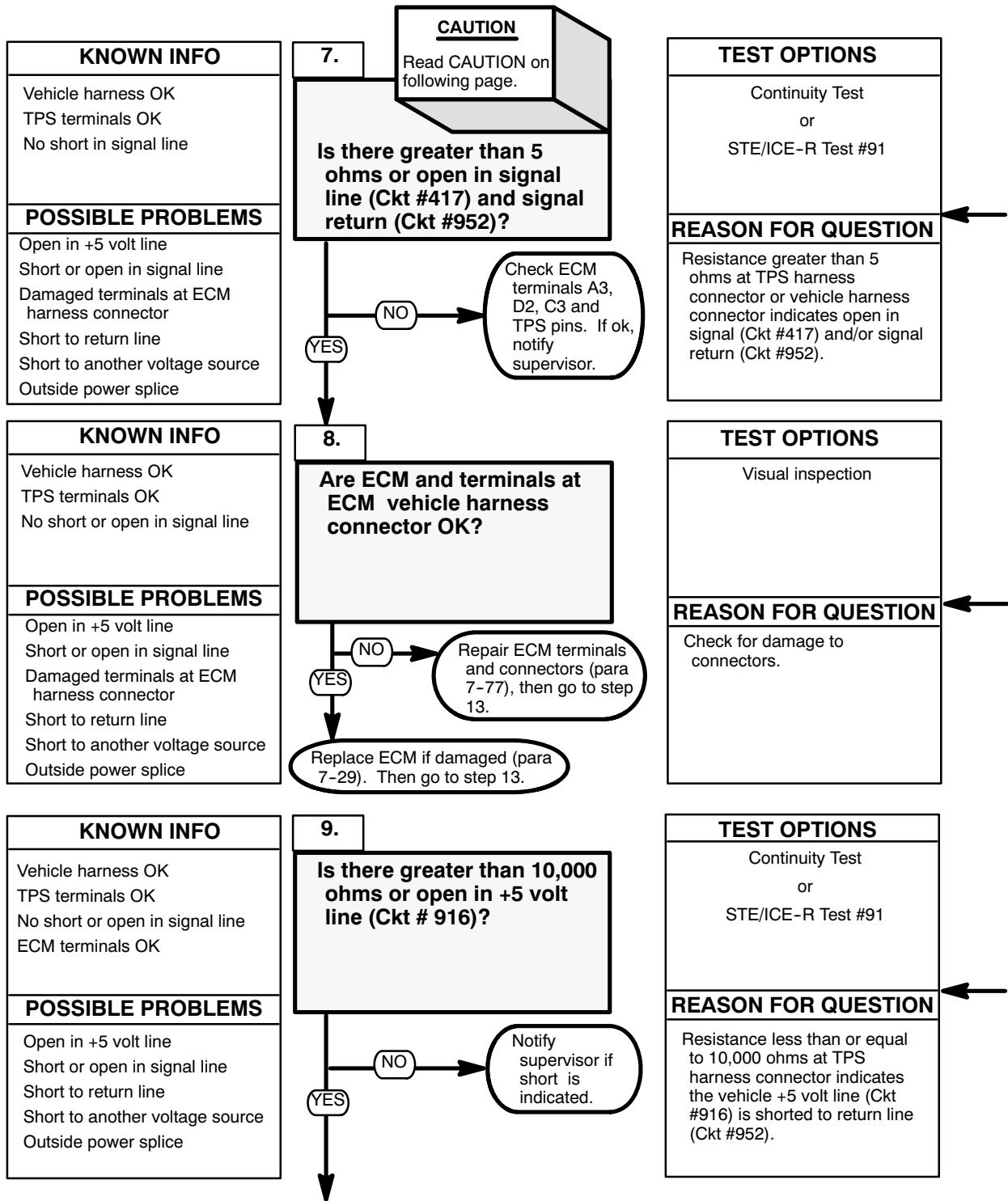
- (1) Remove jumper and turn ENGINE switch ON.
- (2) Read voltage on TPS harness connector, socket C (red lead) to socket A (black lead).

CONTINUITY TEST

- (1) Turn ENGINE switch OFF and disconnect vehicle harness connector at ECM.
- (2) Read resistance between sockets A and B on TPS harness connector.
- (3) Read resistance between Socket B and a good ground.



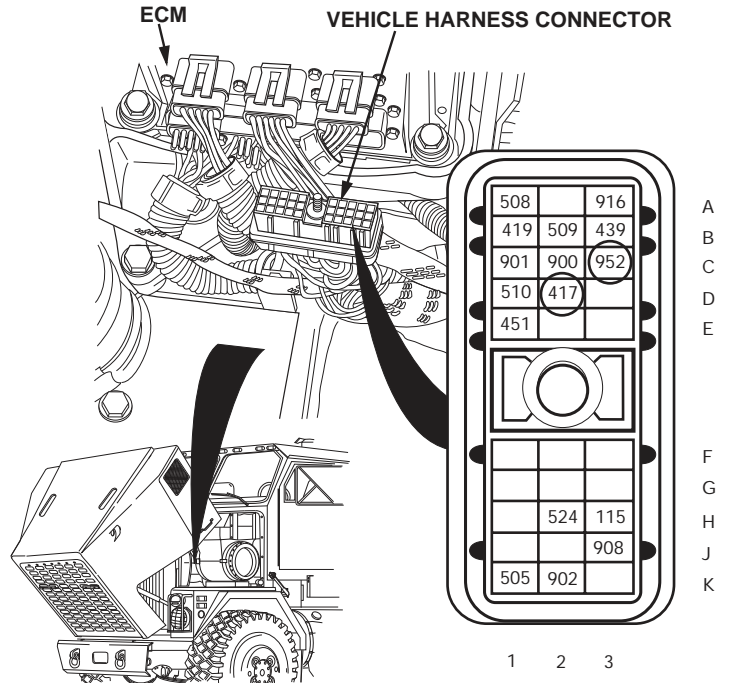
A4 - Code 22 THROTTLE POSITION SENSOR (TPS) SIGNAL VOLTAGE LOW (CONT)



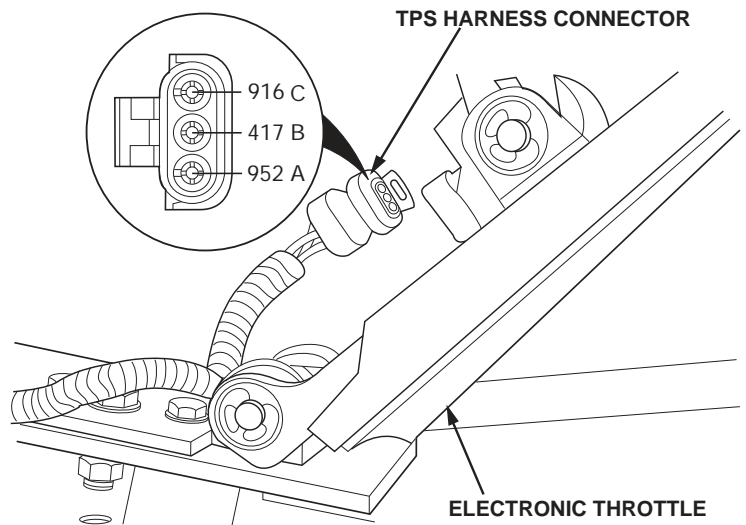
CAUTION
Use jumper wire only between terminals indicated. Failure to comply may result in damage to DDEC components or wiring.

CONTINUITY TEST

- (1) Install a jumper wire between sockets A and B of the TPS harness connector.
- (2) Read resistance between sockets D2 and C3 on vehicle harness connector.

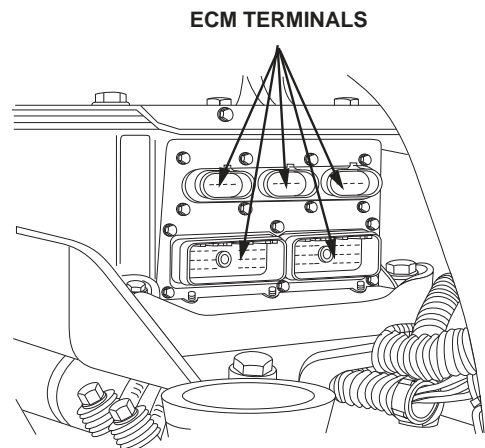


Check ECM and terminals at ECM vehicle harness connector (both ECM and harness side) for damage; bent, corroded, and unseated pins and sockets.

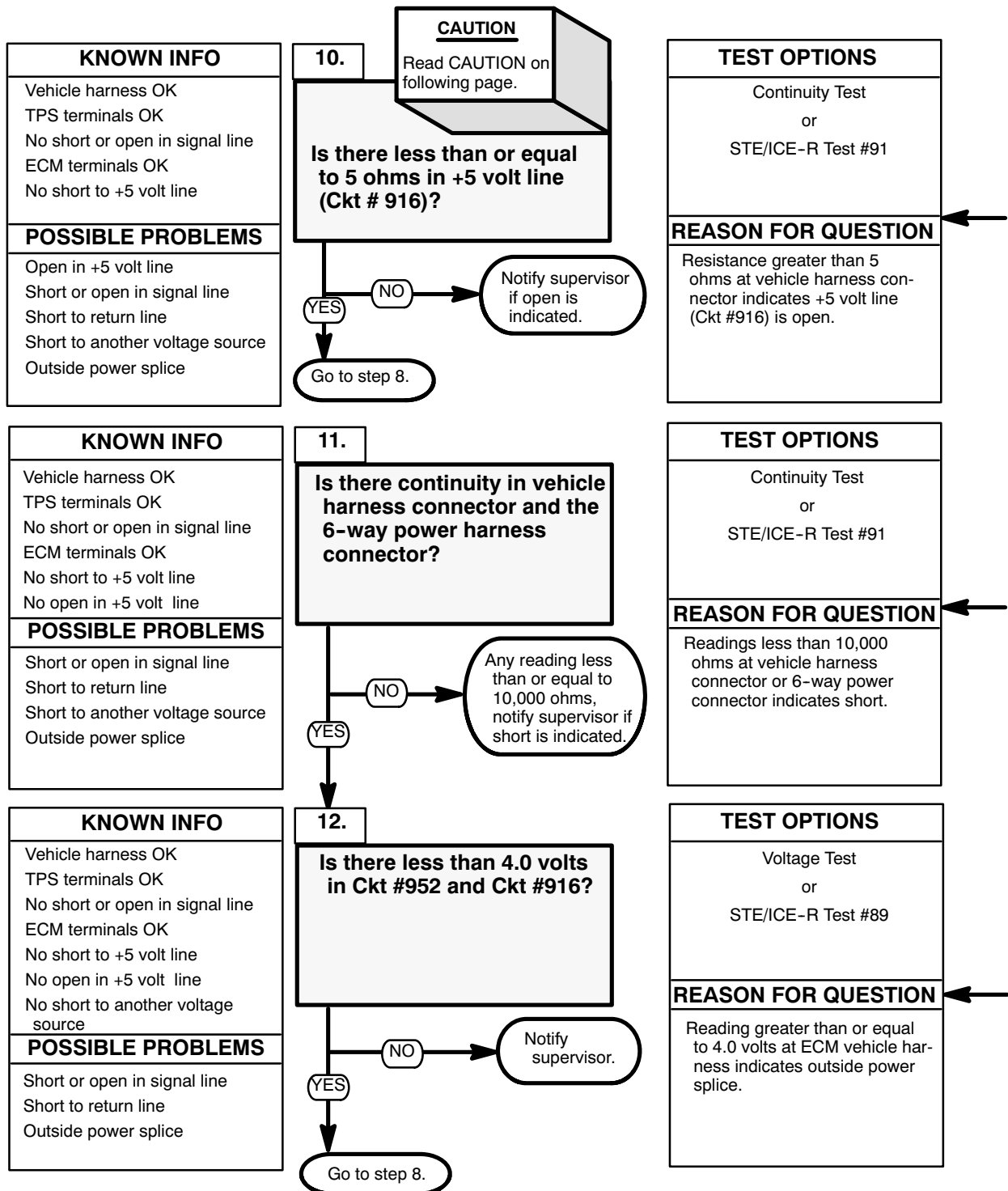


CONTINUITY TEST

- (1) Turn ENGINE switch OFF and disconnect vehicle harness connector at ECM.
- (2) Read resistance between sockets A and C on TPS harness connector.



A4 - Code 22 THROTTLE POSITION SENSOR (TPS) SIGNAL VOLTAGE LOW (CONT)



KNOWN INFO
Vehicle harness OK TPS terminals OK No short or open in signal line ECM terminals OK No short to +5 volt line No open in +5 volt line No short to another voltage source
POSSIBLE PROBLEMS
Short or open in signal line Short to return line Outside power splice

12.

Is there less than 4.0 volts in Ckt #952 and Ckt #916?

YES → Go to step 8.

NO → Notify supervisor.

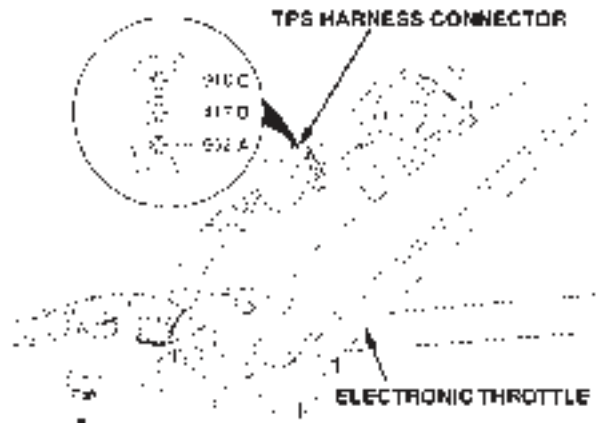
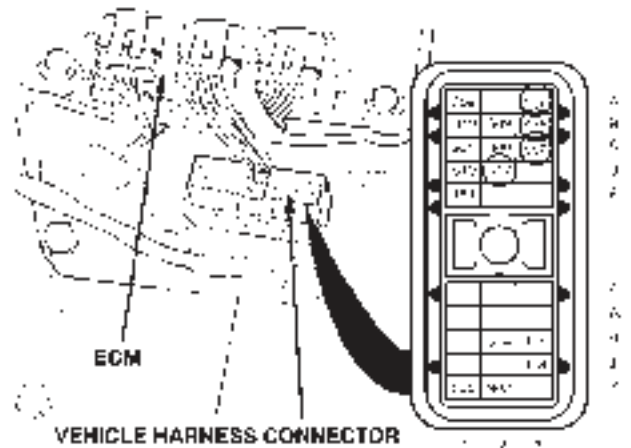
TEST OPTIONS
Voltage Test or STE/ICE-R Test #89
REASON FOR QUESTION
Reading greater than or equal to 4.0 volts at ECM vehicle harness indicates outside power splice.

CAUTION

Use jumper wire only between terminals indicated. Failure to comply may result in damage to DDEC components or wiring.

CONTINUITY TEST

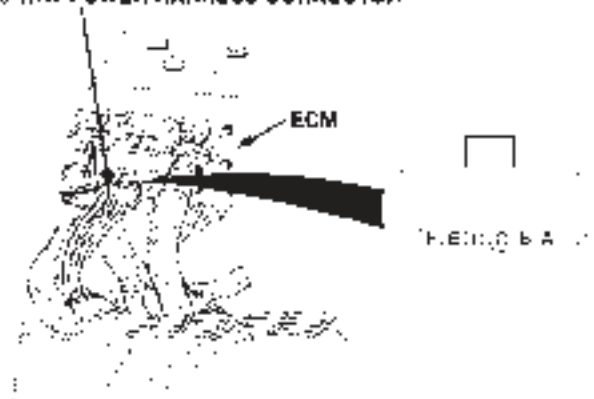
- (1) Install a jumper wire between sockets A and C of the TPS harness connector.
- (2) Read resistance between sockets A3 and C3 on vehicle harness connector.



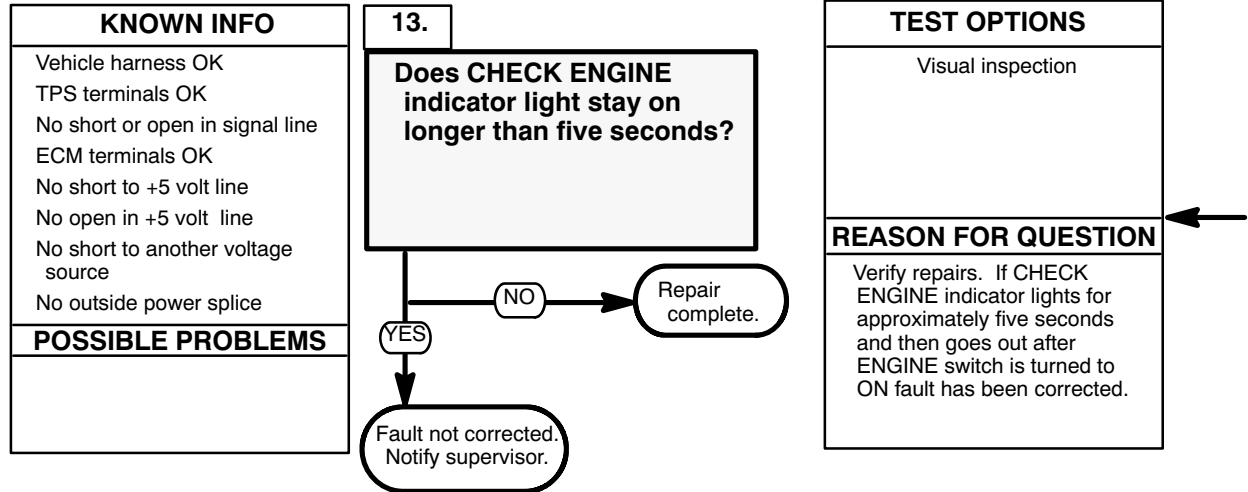
6-WAY POWER HARNESS CONNECTOR

VOLTAGE TEST

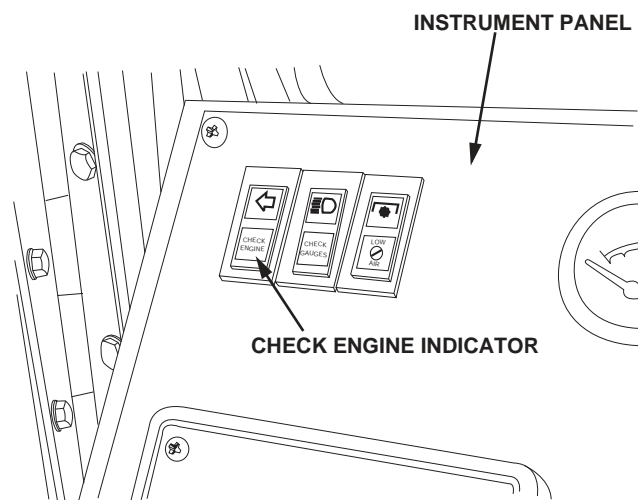
- (1) Turn ENGINE switch ON and read voltage A3 (red lead) to a good ground (black lead).
- (2) Read voltage C3 (red lead) to a good ground (black lead)



A4 - Code 22 THROTTLE POSITION SENSOR (TPS) SIGNAL VOLTAGE LOW (CONT)



- (1) Turn ENGINE switch OFF.
- (2) Reconnect all harness connectors.
- (3) Turn ENGINE switch ON and observe CHECK ENGINE indicator.



A4 - Code 23 FUEL TEMPERATURE SENSOR (FTS) SIGNAL VOLTAGE HIGH

