

VOLTAS

KION India

KION
GROUP

MAX Power
MAX Performance
MAX Productivity

Capacity : 1500 / 2000 kg at 500 mm LC





DRIVE MOTOR

Drive motor is AC Traction motor with class "F" insulation is designed to provide high starting torque and withstand high temperatures in the most demanding applications. Highly energy efficient in the entire variable working condition and it is absolutely maintenance free.

HOIST MOTOR

The hoist motor is supported on rubber pads for reduced vibration and noise emission. The motor is series wound with class F insulation and internal cooling fan OR alternatively AC Motor for maintenance free operation. Pump motor is managed by dedicated pump controller optimizing the motor performance in accordance with demand thus giving high operating efficiency & motor life and also eliminating the separate steer motor.

DRIVE CONTROL

A "State of the art" high power solid-state microprocessor based traction control - inverter controlled AC motor controller. This will provide Hare & Tortoise control with Regenerative Braking.

A Self diagnostic with on board display system is built into the controller, which constantly monitors the electrical control system and indicates diagnostic codes. The control system provides smooth step-less acceleration, variable speed control and precise inching and maneuvering in confined areas.

The regenerative Braking feature is so effective that it nearly eliminates the use of foot brake thus saving energy and reducing operator fatigue. The Battery Connector is located adjacent to the Operator for quick battery disconnection.

TRANSMISSION

A three stage reduction drive train features helical gear reduction specially designed for smooth & silent operation. Traction motor can be installed or removed without affecting the gear mesh. A full floating axle design ensures that tyre loads are carried by the axle housing and not by the drive shafts.

BRAKES

Heavy duty brakes linings are bonded to steel shoes and operate against independently mounted brake drums. Brakes are Self adjusting. The service brake is operated by an ergonomically located pedal. The mechanical parking brake is released by a handle located on the cowl.

MAST, CARRIAGE & FORKS

An excellent design supported by superior welding process ensures highly durable and dependable High Visibility masts. High Visibility simplex mast is standard. Optional Full Free Lift Triplex mast variations are available for a variety of applications including container stuffing/de-stuffing. High visibility carriage with improved visibility is standard. Forks are of world-class quality.

STEER AXLE

The axle is fabricated from steel plates for durability and strength. The axle is supported in the frame by using hardened steel bushing for providing the required articulation. The integrated balanced power cylinder is well protected inside the axle body. The axle assembly uses plain pin joints for ease of maintenance. It provides accurate steering geometry, minimizes tyre wear and allows sharp angle steering for greater maneuverability.

HYDROSTATIC POWER STEERING

The Load sensing hydrostatic power steering provides a finger touch effortless, smooth steering, enhancing operator comfort. To conserve battery energy, the pump motor operates for minimal required speed. In the unlikely event of pump pressure failure, the truck can be steered to controlled stop.

FRAME, BATTERY COMPARTMENT AND CANOPY

The frame is designed using computer aided modeling and optimized by finite element analysis techniques. It is fabricated from heavy steel plates using latest welding process, ensuring excellent rigidity and strength

Located below within the chassis the battery is restrained in position by pads. Hood assembly is supported by gas springs for ease of opening to access battery.

An elegant canopy integrated with the frame body provides a safe enclosure for operator conforming to IS: 7621 (2000)

HYDRAULIC SYSTEM

Hydraulic system consists of reservoir, pump, directional control valve, cylinders and full flow filtration system with bypass protection, suction strainer and 25-micron replaceable return line filter. Pressure relief, Tilt lock and Flow regulators are provided for safety. The tilt lock feature control valve protects against inadvertent forward tilt whilst providing precise load positioning. Pump motor performance is synchronized with hydraulic flow demand thus enabling power saving with enhanced operator safety.

INSTRUMENTATION AND CONTROLS

Pedals are provided for acceleration and braking. These are located ergonomically with ample leg room for the operator. Dual direction lever is automotive type mounted on the steering column for easy operation. Hydraulic control valve levers are ergonomically positioned for fatigue free operation.

Hour meter and Battery State of Charge gauge housed in an elegantly designed FRP housing are available as standard. An enhanced dash display provides battery state of charge display. Controller diagnostic, fault code readouts are displayed to minimize downtime.

OPTIONAL

1. All AC drive
2. Non marking tyres instead of standard molded rubber tyres
3. Higher Battery options upto 550 AH
4. Pneumatic tyres

SALIENT FEATURES



Powerful, energy efficient drive line



Heavy duty steer axle for rugged operations



Side mounted controller for easy maintenance



Side mounted hoist motor for easy maintenance



48V battery & AC traction for longer hours of operation



Minimum rear overhang for less turning radius



Large front tyres for enhanced road grip and stability



Elegant Instrument Panel with on board diagnostics



Ergonomically located levers for ease in operation



Ample leg room for operator comfort



Large operator hand assisted access grip



Deluxe adjustable seat with Arm rest & seat belt for operator safety



Wide view mast for clear front operator visibility



Wider Operator foot rest for safer entry and exit



High Mounted Rear Combination and Beacon Lights.



Easy access combination switch

MAST CONFIGURATIONS

TYPE OF MAST	MAST MODEL	OAH h1 mm	FFH h2 mm	MFH h3 mm	OAH @ MFH with LBR h4 mm	TILT ANGLE DEGREE FWD / BWD	CAPACITY (Kg) at MFH @ 500 mm LC
							EVX 15 / 20 AC
2-Stage	HVM	2350	Nil	3500	4700	6 / 10	1500 / 2000
3-Stage	HVT-2125	2125	1420	4500	5745	3 / 5	1600
3-Stage	HVT-2520	2520	1780	5350	6595	3 / 5	1400
3-Stage	HVT-2700	2700	2140	6090	7335	3 / 5	1200

OAH : Overall Mast Height FFH : Free Fork Height MFH : Max Fork Height FWD : Forward BWD : Backward

* Capacity shall derate by 200 kg with sidershifter.

SPECIFICATIONS				
CHARACTERISTICS	1.1	MANUFACTURER	VOLTAS MATERIAL HANDLING	
	1.2	MODEL DESIGNATION	EVX15 / 20 AC	
	1.3	POWER UNIT	BATTERY	
	1.4	OPERATION	SEATED	
	1.5	LOAD CAPACITY	Q (kg)	2000
	1.6	LOAD CENTRE	C (mm)	500
	1.7	AXLE CENTRE TO FORK FACE	X (mm)	400
	1.8	WHEEL BASE	Y (mm)	1400
WEIGHT	2.1	SERVICE WEIGHT	Kg	3170
	2.2	AXLE LOAD LADEN, FRONT / REAR	Kg	4480 / 660
	2.3	AXLE LOAD UNLADEN, FRONT / REAR	Kg	1250 / 1920
WHEELS AND TYRES	3.1	TYRE	SOLID (STD), PNEUMATIC (OPTIONAL)	
	3.2	TYRE SIZE, FRONT	21 x 7 x 15'	
	3.3	TYRE SIZE, REAR	18 x 7-8-12'	
	3.4	WHEELS, NUMBER FRONT / REAR (x drive)	2 / 2	
	3.5	TRACK WIDTH, FRONT	b10 mm	960
	3.6	TRACK WIDTH, REAR	b11 mm	920
DIMENSIONS	4.1	MAST TILT, FORWARD / BACKWARD	α / β	6 / 10
	4.2	MAST HEIGHT, LOWERED	h1 mm	2350
	4.3	FREE LIFT	h2 mm	NIL
	4.4	MAX LIFT	h3 mm	3500
	4.5	MAST HEIGHT, EXTENDED	h4 mm	4100
	4.6	HEIGHT OF OVERHEAD GUARD	h6 mm	2140
	4.7	LENGTH TO FORK FACE	L2 mm	2100
	4.8	OVERALL WIDTH	b1 mm	1150
	4.9	FORK DIMENSIONS	s/e1 mm	40 x 100 x 1070
	4.10	FORK CARRIAGE, ISO CLASS		2A
	4.11	FORK SPREAD	b3	960
	4.12	GROUND CLEARANCE AT FRAME	m2 mm	120
	4.13	aisle width pallet 1000x1200 across fork	Ast mm	3550
	4.14	TURNING RADIUS	Wa mm	1900
PERFORMANCE	5.1	TRAVEL SPEED, WITH / WITHOUT LOAD	km / h	11 / 11
	5.2	LIFTING SPEED, WITH / WITHOUT LOAD	m / s	0.25 / 0.35
	5.3	LOWERING SPEED, WITH / WITHOUT LOAD	m / s	0.45 / 0.4
	5.4	GRADABILITY WITH / WITHOUT LOAD	%	17 / 17
	5.5	SERVICE BREAK		HYDRAULIC
DRIVE	6.1	MOTOR TYPE		AC MOTOR
	6.2	DRIVE MOTOR, AC	KW	8 KW, 60 MINUTES RATING
	6.3	LIFT MOTOR RATING, DC	KW	8 KW, 15 MINUTES RATING
	6.4	BATTERY VOLTAGE / RATED CAPACITY	V / AH	48V / 440
	6.5	BATTERY WEIGHT	kg	730

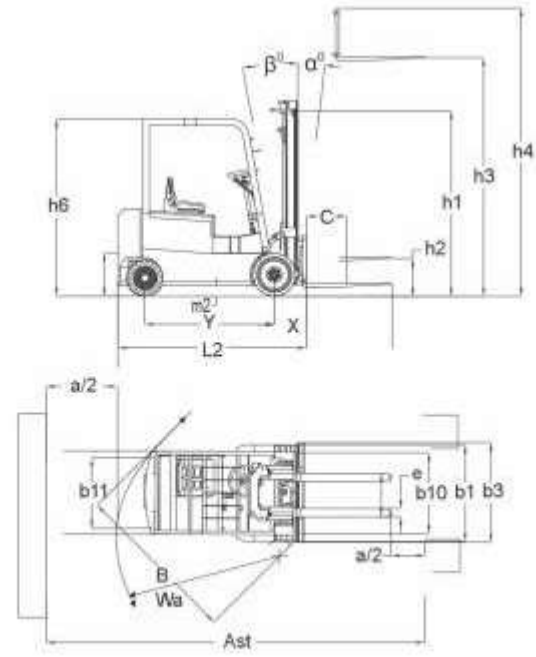
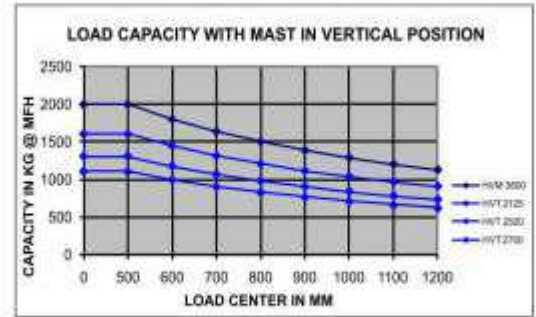

SAFETY: TRUCK CONFORMS TO STABILITY REQUIREMENT AS PER 'BIS & 'ISO' STANDARDS. ALL SPECIFICATIONS ARE SUBJECT TO +/- 12% TOLERANCE
DUE TO CONTINUOUS DESIGN IMPROVEMENTS THE SPECIFICATIONS ARE SUBJECT TO CHANGE WITHOUT NOTICE.

VOLTAS

KION India Pvt. Ltd.

Plant & HO : 5/4 Chandan Nagar, Pune - Nagar Road,
Pune - 411 014, Maharashtra
Visit Us at : www.voltas-mh.com

For Enquiries
e-mail : in.enquiries@kiongroup.com
Contact us : 020 - 6732194 / 188 / 190 / 193

BRANCHES

Ahmedabad 9925013566 • Bangalore 9731017401 • Bhubaneswar 9090963883 • Chandigarh 9878677873
Chennai 8680067711/8680067712 • Cochin 9747357888 • Coimbatore 9747397666/9747357888 • Delhi 7840010261
Hyderabad 9010150999 • Indore 7770862223 • Jaipur 9352573157 • Jamshedpur 9031098801 • Kolkata 9088026730
Lucknow 9889033532 • Madurai 9840234189/8680067712 • Mumbai 7774027853/7774027851 • Nagpur 7774027836
Pune 7774027840 • Rudrapur 8057405111 • Surat 7624005557 • Vizag 9951066618

DEALERS

Agartala 9435993430 • Ahmedabad 8347009991 • Ankleshwar 8347000648 • Aurangabad 9657722566
Bangalore 9449857458 • Baroda 8347009993 • Bhopal 9826052942 • Bhubaneswar 9238310721 • Chakan 9604503624
Chandigarh 9463998214 • Chennai 9940052996 • Cochin 8129400987 • Coimbatore 9842315181
Delhi 9899684448/9711206090 • Durgapur 9830194044 • Erode 9842015187 • Gandhidham 8347009982
Goa 9423312625/9850471387 • Guwahati 9435993430 • Haldia 9830194044 • Hosur 9629302584 • Hubli 9482233151
Hyderabad 9032047822 • Indore 9826052942 • Itanagar 9435993430 • Jabalpur 9826052942 • Jaipur 9414159451
Jaipur 9090963883 • Jamshedpur 9798426330 • Jharsuguda 9090963883 • Jodhpur 9414159451 • Jorhat 9435993430
Kolhapur 9922996273 • Kolkata 9830194044 • Kota 9414189976 • Lucknow 9415005471 • Ludhiana 9463998214
Madurai 9750955044 • Mangalore 9482233151 • Mumbai 9324267044 • Mysore 9449857458 • Nagpur 9552470007
Nasik 8600921789 • Nellore 9959194936 • Palghat 8129192277 • Pantnagar 8057405111 • Patna 9031464206
Pondicherry 9787735921 • Pune 9922996269 • Raipur 8236835202 • Rajkot 8347000647 • Ranipet 9787735921
Roorkee 9219000900 • Salem 9715415181 • Shillong 9435993430 • Siliguri 9830194044 • Surat 9909981641
Taloja 8888996333 • Tirunelveli 9750955044 • Trichy 9750955044 • Trivandrum 9995801271 • Udaipur 9414159451
Vapi 9978901772 • Varanasi 9415005471 • Vijaywada 9966112330 • Vizag 9885011142



F.MKT:MH:302:140:00