

*1/4* *62* *U113*  
*TM*  
*1944*

# TM 9-820

WAR DEPARTMENT TECHNICAL MANUAL

---

*U.S. Dept. of Army*

## TRACTOR TRUCK (FEDERAL)

4- TO 5-TON, 4x4

---

WAR DEPARTMENT • 15 MARCH 1944



TRACTOR TRUCK  
(FEDERAL)  
4- TO 5-TON, 4x4



WAR DEPARTMENT

15 MARCH 1944

---

WAR DEPARTMENT

WASHINGTON 25, D. C., 15 March 1944

TM 9-820, Tractor Truck (Federal), 4- to 5-ton, 4 x 4, is published for the information and guidance of all concerned.

[AG 300.7 (18 Nov 43)]

[COM 481/Rar Aca (3-17-44)]

BY ORDER OF THE SECRETARY OF WAR:

G. C. MARSHALL,  
*Chief of Staff.*

OFFICIAL:

J. A. ULIO,  
*Major General,*  
*The Adjutant General.*

DISTRIBUTION: X

(For explanation of symbols, see FM 21-6.)

# CONTENTS

11113  
.2.  
T.M. 9-820  
1944



## PART ONE—VEHICLE OPERATING INSTRUCTIONS

	Paragraphs	Pages
SECTION I. Introduction . . . . .	1	5
II. Description and tabulated data . . . . .	2- 3	5- 8
III. Driving controls and operation . . . . .	4- 6	8- 15
IV. Operation under unusual conditions . . . . .	7- 10	16- 23
V. First echelon preventive maintenance services . . . . .	11- 15	23- 35
VI. Lubrication . . . . .	16- 17	35- 43
VII. Tools and equipment stowage on the vehicle . . . . .	18	44- 45

## PART TWO—VEHICLE MAINTENANCE INSTRUCTIONS

SECTION VIII. Vehicle modification records . . . . .	19	46
IX. New vehicle run-in test . . . . .	20- 21	46- 51
X. Second echelon preventive maintenance . . . . .	22	51- 78
XI. Organization tools and equipment . . . . .	23	79
XII. Trouble shooting . . . . .	24- 45	79- 98
XIII. Engine data, maintenance, and adjustment in vehicle . . . . .	46- 55	99-113
XIV. Engine removal and installation . . . . .	56- 57	113-124
XV. Clutch . . . . .	58- 60	125-129
XVI. Fuel system . . . . .	61- 66	129-138

\*This Technical Manual, together with TM 9-1816 and TM 9-1832A, supersedes TM 10-1107, dated 10 July 1941, TM 10-1407, dated December 1942, and TM 10-1459, dated 2 February 1942. In addition, this manual supersedes all pertinent information from TB 800-21, dated 30 November 1943 and TB ORD 20, dated 24 January 1944.

# CONTENTS—Cont'd

## PART TWO—VEHICLE MAINTENANCE INSTRUCTIONS—

Cont'd

		Paragraphs	Pages
SECTION XVII.	Intake and exhaust systems	67- 71	139-143
XVIII.	Cooling system . . . . .	72- 78	143-154
XIX.	Ignition system	79- 85	154-162
XX.	Starting and generating systems . . . . .	86- 92	162-173
XXI.	Transmission	93- 95	173-176
XXII.	Transfer case . . . . .	96-100	176-179
XXIII.	Propeller shafts and universal joints . . . . .	101-104	180-183
XXIV.	Front axle . . . . .	105-108	183-186
XXV.	Rear axle	109-111	186-188
XXVI.	Service brake system	112-128	188-212
XXVII.	Propeller shaft brake system	129-133	212-215
XXVIII.	Wheels, hubs, wheel bearings, and tires . . . . .	134-136	215-220
XXIX.	Springs and shock absorbers	137-139	220-223
XXX.	Steering gear . . . . .	140-144	223-226
XXXI.	Body and frame . . . . .	145-153	226-233
XXXII.	Battery and lighting system	154-169	233-249
XXXIII.	Instruments	170-177	250-256
XXXIV.	Fifth wheel	178-180	256-257
XXXV.	Radio noise suppression system	181-185	257-261
XXXVI.	Shipment and temporary storage . . . . .	186-188	261-265
REFERENCES			265-267
INDEX . . . . .			268-283

## PART ONE

# VEHICLE OPERATING INSTRUCTIONS

### Section I

## INTRODUCTION

#### 1. SCOPE.\*

a. This Technical Manual is published for the information and guidance of the using arms personnel charged with the operation, maintenance, and minor repair of this materiel.

b. In addition to a description of Federal, 4- to 5-ton, 4 x 4 tractor truck, this manual contains technical information required for the identification, use, and care of the materiel. The manual is divided into two parts: Part One, section I through section VII, gives operating instructions; Part Two, section VIII through section XXXV, gives vehicle maintenance instructions to using arm personnel charged with the responsibility of doing maintenance work within their jurisdiction.

c. In all cases where the nature of the repair, modifications, or adjustment is beyond the scope or facilities of the unit, the responsible ordnance service should be informed so that trained personnel with suitable tools and equipment may be provided, or proper instructions issued.

---

### Section II

## DESCRIPTION AND TABULATED DATA

#### 2. DESCRIPTION (figs. 1 and 2).

a. **General.** The Federal, 4- to 5-ton, 4 x 4 tractor truck is a cab-over-engine, open-cab type vehicle. It is powered by a Hercules, Model RXC engine. A four-wheel drive system of power transmission permits use of the front wheel drive when necessary, through a centrally located transfer case. The truck has dual rear wheels and provisions for carrying two spare tires at rear of cab. The front of the truck mounts a heavy solid-bar bumper surmounted with a relatively straight vertical protective radiator brush guard. Midway between the front and rear wheels and outside the frame on the left side is the rectangular, 60-gallon fuel tank (fig. 2). The battery box and the tool box (fig. 1) are located in a similar position on the right side.

---

\*To provide operating instructions with the materiel, this Technical Manual has been published in advance of complete technical review. Any errors or omissions will be corrected by changes, or, if extensive, by an early revision.



4- TO 5-TON 4x4 TRACTOR TRUCK (FEDERAL)



Figure 1 - Tractor Truck - Right Front View

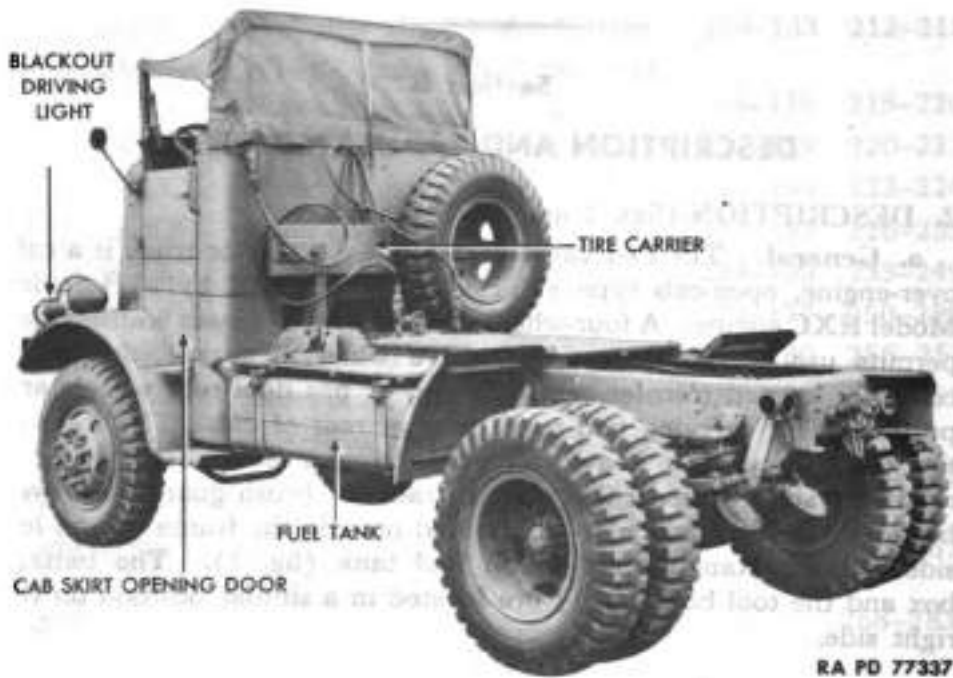

Figure 2 - Tractor Truck - Left Rear View



## DESCRIPTION AND TABULATED DATA

b. This truck comes equipped with two types of cabs. Some have open-type cabs and some have closed cabs.

## 3. DATA.

## a. Vehicle Specifications.

Tractor truck manufacturer	Federal Motor Co
Tractor truck, model number	94X43C
Weight of vehicle:	
Empty	11,950 lb
Loaded	20,220 lb
Length, over-all (uncrated)	202 $\frac{3}{8}$ in.
Width, over-all (uncrated)	95 $\frac{1}{2}$ in.
Height, over-all (top up)	109 in.
Wheel base	134 $\frac{3}{8}$ in.
Tire:	
Size	9:00 x 20—10 ply
Type	Mud and snow
Tread (center-to-center):	
Front	73 $\frac{3}{4}$ in.
Rear, inside	59 $\frac{3}{4}$ in.
Rear, outside	34 $\frac{1}{2}$ in.
Weight distribution:	
Front axle	6,831 lb
Rear axle	13,389 lb
Ground clearance:	
Front	11 $\frac{1}{2}$ in.
Rear	12 in.
Pintle height	38 in.
Maximum speed	40 mph

## b. Performance.

Speeds allowable without front wheels driving:

1st gear	4 mph
2nd gear	8 mph
3rd gear	17 mph
4th gear	31 mph
5th gear	40 mph

Speeds allowable with front wheels driving:

1st gear	4 mph
2nd gear	8 mph
3rd gear	10 mph
4th gear	10 mph
5th gear	10 mph

Minimum turning radius 27 ft

## 4- TO 5-TON 4x4 TRACTOR TRUCK (FEDERAL)

## Towing facilities:

Front	Two hooks
Rear	1 pintle hook
Maximum draw-bar pull (in 4th gear)	450 lb
Maximum allowable engine speed	2,400 rpm
Miles per gallon	3 to 5
Cruising range	180 miles

## c. Capacities.

Transmission	10 qt
Transfer Case	2 qt
Front axle	6 qt
Rear axle	6 qt
Fuel tank (70 or higher octane gasoline)	62½ gal
Cooling system	40 qt
Crankcase	10 qt
Oil bath air cleaner	.3 pt
Steering gear	1½ pt

## Section III

## DRIVING CONTROLS AND OPERATION

## 4. INSTRUMENTS AND CONTROLS.

a. **Propeller Shaft Brake Lever** (fig. 3). The propeller shaft brake lever is the first lever which comes through the floor board to the right hand of the driver's seat. It is primarily a parking brake but can be used in an emergency as a stopping brake.

b. **Main Transmission Gearshift Lever** (fig. 3). This lever comes through the large floor board opening at the right of the driver's seat and is the first lever to the right of the propeller shaft brake lever. It is used to shift all gears in the main transmission. It has five forward positions and one reverse position.

c. **Transfer Case Shift Lever** (fig. 3). The transfer case shift lever also comes through the large floor board opening and is located to the right and adjacent to the main transmission gearshift lever. This lever has a high, a low, and a neutral position and controls the transfer case gears.

d. **Front Axle Declutch Lever** (fig. 3). The front axle declutch lever is the third lever which comes through the large floor board opening and is to the right and adjacent to the transfer case shift lever. This lever controls the front axle drive. There is an "IN" and "OUT" position.

**DRIVING CONTROLS AND OPERATION**

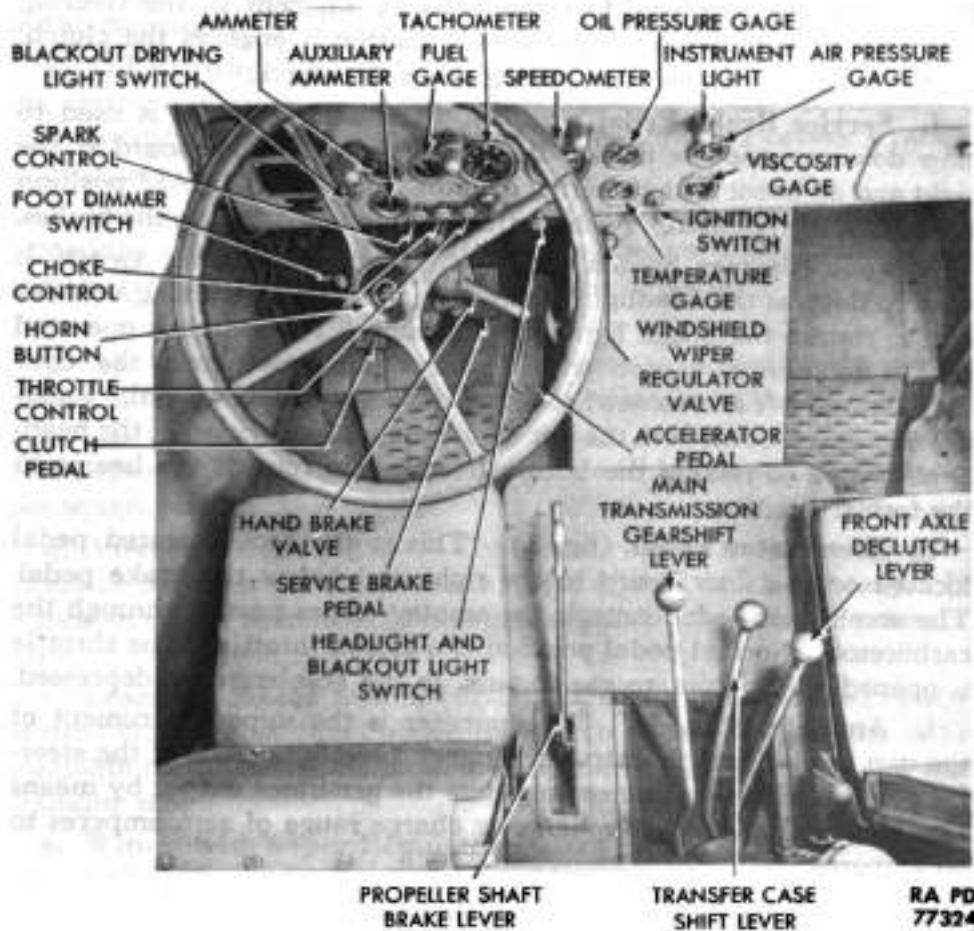

**Figure 3 – Operator's Controls**

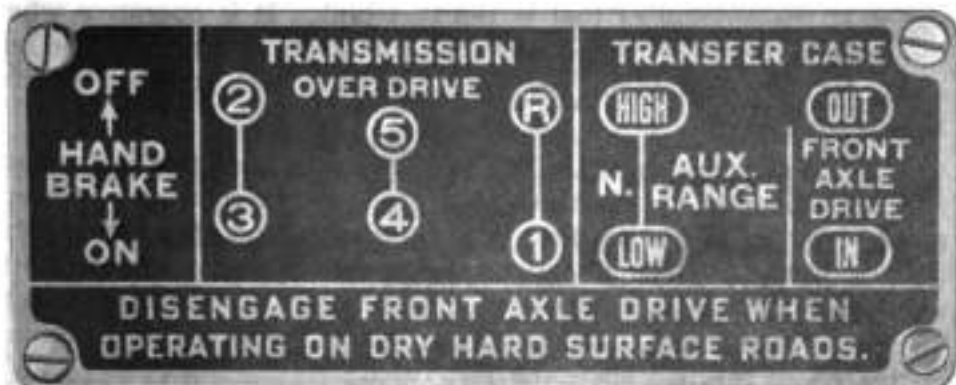

**RA PD 77305**

**Figure 4 – Gearshift Instruction Plate**

**4- TO 5-TON 4x4 TRACTOR TRUCK (FEDERAL)**

e. **Clutch Pedal** (fig. 3). The clutch pedal is the foot pedal located on the floor board at the left and adjacent to the steering column. In its "UP" or "NORMAL" position it engages the clutch. In its "FORWARD" position it disengages the clutch.

f. **Service Brake Pedal** (fig. 3). The service brake is used to slow down or stop the truck. It is located on the floor board at the right and adjacent to the steering column. In its "NORMAL" position the brakes are released. Pushing the pedal forward applies the brakes.

g. **Foot Dimmer Switch** (fig. 3). The foot dimmer switch is used to depress the headlight beams when meeting oncoming vehicles and to restore the bright lights after passing. The switch is operated by the cylindrical button which protrudes upward from the floor board at the left and somewhat forward from the clutch pedal. Pressing the button down with the left foot changes the position of the headlight beams. Pressing the button down again returns the beams to the former position.

h. **Accelerator Pedal** (fig. 3). This is the foot operated pedal located on the floor board to the right and below the brake pedal. The accelerator pedal controls the amount of gas passing through the carburetor. Normal pedal position is a closed throttle. The throttle is opened, allowing more gas to pass, as the accelerator is depressed.

i. **Ammeter** (fig. 3). The ammeter is the upper instrument of the two located on the instrument panel directly in front of the steering column. This instrument registers the generator output by means of a hand. It covers a discharge or charge range of zero amperes to 50 amperes.

j. **Auxiliary Ammeter** (fig. 3). The auxiliary ammeter is the instrument on the instrument panel located directly below the ammeter. Its purpose is to indicate charge or discharge operation of auxiliary storage battery.

k. **Fuel Gage** (fig. 3). The fuel gage is an instrument which indicates the amount of fuel in the fuel tank. It is operative when the ignition switch is turned on. The fuel gage is located at the left center of the instrument panel at the right and adjacent to the ammeter.

l. **Tachometer** (fig. 3). The tachometer is the large instrument located left center on the instrument panel, at the right and adjacent to the fuel gage. Its purpose is to register engine speed in revolutions per minute. The indicating hand covers a range of zero to 2,500 revolutions per minute. The key control located just below the tachometer is used to reset the red hand which registers the maximum engine speed reached since the last reset.

m. **Speedometer** (fig. 3). This instrument indicates road speed in miles per hour and records both trip and total mileage. It is located

## DRIVING CONTROLS AND OPERATION

on the left center of the instrument panel at the right and adjacent to the tachometer.

n. **Oil Pressure Gage (fig. 3).** The oil pressure gage is located on the instrument panel at the right and adjacent to the speedometer. This instrument indicates the engine oil pressure and covers a range of from zero to 80 pound per square inch.

o. **Temperature Gage (fig. 3).** This gage indicates the temperature of the water in the engine. It covers a range of 100° F. to 220° F. It is located on the instrument panel directly below the oil pressure gage.

p. **Air Pressure Gage (fig. 3).** This gage is located on the center of the instrument panel at the right and adjacent to the oil pressure gage. It shows the amount of air pressure available in the service brake system. The gage registers from zero to 150-pound air pressure per square inch.

q. **Viscosity Gage (fig. 3).** The viscosity gage indicates the condition of the oil in the crankcase in terms of thin, ideal, or heavy. It is located on the center of the instrument panel below the air pressure gage.

r. **Cranking Motor Switch (fig. 5).** This is a foot operated switch located on the dash panel above the clutch pedal. Its purpose is to complete the electrical contact between the storage batteries and the cranking motor.

s. **Windshield Wiper Regulator Valves (fig. 3).** These consist of two small knobs located on a small subpanel connected to the instrument panel below the temperature gage. The left knob controls the wiper in front of the driver's seat and the right knob controls the wiper to the right. Turning the knob counterclockwise opens the valve starting the wiper and also controls its speed. Turning knob clockwise closes the valve and stops the wiper.

t. **Headlight and Blackout Light Switch (fig. 3).** This is a push-pull type switch with four positions. All lights are out in the first position when the knob is pushed all the way in. Pulling the knob out to the second position lights only the blackout lights. A spring plunger lock holds switch in this position. Releasing plunger and pulling switch out to the "THIRD" position lights headlights, service tail and stop lights. In this position instrument panel lights can be lighted by their separate switch. Pulling switch all the way out to the "FOURTH" position lights the service stop light when the brakes are applied; all other lights are out. The switch knob is located at the left center of instrument panel directly below the speedometer.

u. **Choke Control (fig. 3).** The choke control knob is located on the lower left of the instrument panel below and to the right of the

**4. 10 5-TON 4x4 TRACTOR TRUCK (FEDERAL)**

auxiliary ammeter. Pulling the knob out reduces the amount of air admitted to the carburetor, thereby making a richer gas mixture. The richness of the mixture is controlled by the distance the knob is pulled from the panel.

v. **Ignition Switch** (fig. 3). The ignition is located in lower center of instrument panel between the temperature and viscosity gage. It is a lever-type switch and controls the engine electrical supply and must be in the left or "ON" position to start engine. The lever should be kept in the right or "OFF" position except when starting engine, operating engine, or checking gage readings.

w. **Throttle Control** (fig. 3). The throttle control knob is located on the lower left of the instrument panel below the speedometer. This control operates by push-pull. Pulling increases the amount of gas and thereby increases the engine speed. Pushing reduces gas and engine speed.

x. **Spark Control** (fig. 3). This is a push-pull type control knob located on the instrument panel below the fuel gage. Pulling out the knob retards the spark and pushing advances the spark. It is used in starting and as a spark adjustment for low grade fuel.

y. **Instrument Lighting Switch** (fig. 95). This is a push-pull type switch and is used to control the instrument panel lights. It can be operated only when the headlight and blackout light switch is in "SECOND" or service position. The instrument lighting switch is located on the instrument panel to the right of the headlight and blackout light switch.

z. **Blackout Driving Light Switch** (fig. 3). This is a push-pull knob type switch and is located at the extreme left of the instrument panel.

aa. **Hand Brake Valve** (fig. 3). This is a hand lever operated valve located on the steering column directly below the steering wheel. This valve independently controls the trailer brake.

bb. **Horn Button**. The horn button is the rounded disk in the top center of the steering column. Depressing the button makes the electrical contact which operates the horn. Releasing or removing the hand pressure breaks the contact.

**5. USE OF INSTRUMENTS AND CONTROLS IN OPERATION OF VEHICLE.**

a. **Before-operation Service**. Perform the services in paragraph 12 before attempting to start the engine.

b. **Starting the Engine**.

(1) Apply propeller shaft brake to hold vehicle stationary.

(2) Place main transmission gearshift lever in neutral position (fig. 4).

**DRIVING CONTROLS AND OPERATION**

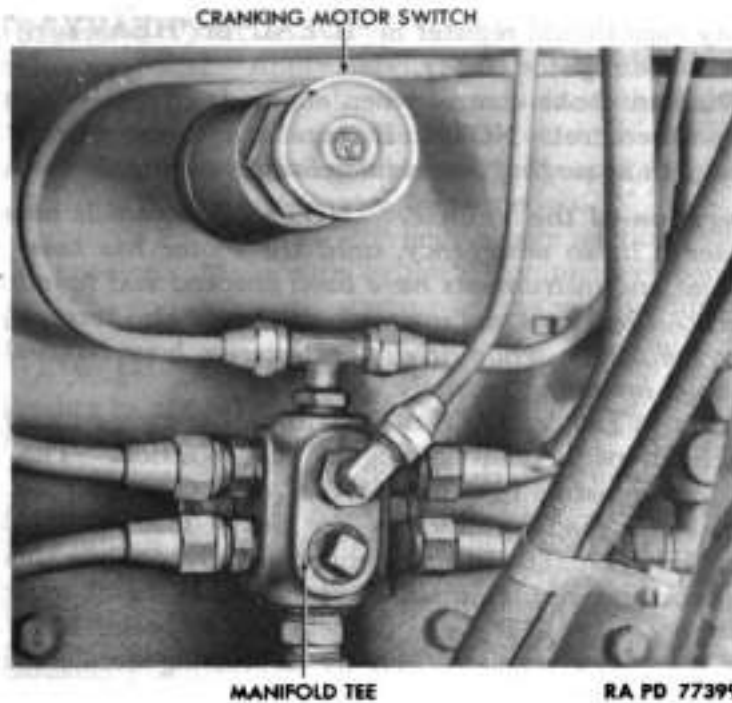

**Figure 5 – Cranking Motor Switch and Oil Manifold Tee Installed**

(3) Pull choke control completely out to provide a rich starting mixture, if the engine is cold. If engine is warm, use only part choke or none at all.

(4) Pull out throttle control about  $\frac{1}{2}$  inch. Less throttle is needed for a warm engine.

(5) Pull out spark control  $\frac{3}{4}$  inch.

(6) Turn ignition switch to "ON" position.

(7) Depress clutch pedal and hold down until engine starts.

(8) Depress cranking motor switch with left foot, until engine starts, then release immediately.

(9) After the engine has started, push in throttle control when engine runs evenly. Read the gages and instruments. The oil pressure gage must register 40 pounds or above. If it registers less, stop the engine immediately and investigate. The air pressure gage must register 60 pounds or above. A buzzing sound, indicating insufficient air pressure for brake operation, will be heard until operating pressure above 60 pounds is reached. The vehicle must not be moved until the buzzing stops. If the buzzer sounds while the vehicle is being operated, stop vehicle immediately and determine cause of loss of air pressure. The ammeter must read "CHARGE." The tachometer should read about 750 revolutions per minute. The water temperature gage should show a gradual rise to 140 to 160 degrees. The



**4- TO 5-TON 4x4 TRACTOR TRUCK (FEDERAL)**

oil viscosity gage should register in "IDEAL" or "HEAVY." The fuel gage should not register empty.

(10) Push in choke control when engine is properly warmed up. Push in spark control. *NOTE: If there is any uneven operation of the engine such as surging or irregular firing, investigate the cause.*

**c. Operation of the Vehicle.** *NOTE: The vehicle must not be moved, except in an emergency, until the motor has been warmed and all gages and instruments have been checked and found registering properly. The gages and instruments should also receive glancing checks by the driver, while driving, at quarter hour intervals to see that engine is operating properly.*

(1) **PLACING THE VEHICLE IN MOTION.** Disengage clutch by depressing clutch pedal and holding in that position. The transfer case shift lever must be in either "HIGH" or "LOW" position depending on load and road conditions. For heavy load use "LOW," for light load, "HIGH." The vehicle cannot be moved while this lever is in neutral position. Move main transmission gearshift lever to first gear position (fig. 4). Release propeller shaft brake lever. While gradually increasing engine speed by depressing accelerator pedal, slowly release clutch pedal until clutch is fully engaged. Increase engine speed until truck gets under way. Shift main transmission into second gear as follows: Depress clutch pedal, place gearshift lever in neutral position, and engage clutch momentarily. Depress clutch pedal again and place gearshift lever in second gear position (fig. 4). Release clutch and increase engine speed. Do not exceed 2,400 revolutions per minute as indicated by tachometer. Repeat this operation, passing through all gears consecutively until the highest gear is reached at which the engine pulls without laboring.

(2) **SHIFTING TO LOWER SPEEDS.** To shift to a lower gear, use same procedure as for shifting to a higher gear, with the following exception. When gearshift lever is in neutral position and clutch is momentarily engaged, accelerate engine to approximate speed required to propel the vehicle at the same speed in the lower gear. Then disengage clutch and quickly shift to lower gear.

(3) **FRONT AXLE DRIVE.** To engage the front axle drive it is necessary to move the front axle declutch lever into its "IN" position. The shifting can be made with the truck standing or in motion; however, it is easier to shift when in motion. The shifting is made easier by disengaging the clutch in the same manner as when shifting the main transmission gears. The front axle must not be engaged if the rear wheels are spinning. This drive should be used for "off-the-road" operation and not when operating the vehicle on dry, hard, surfaced roads. The front axle drive is not in use when the lever is in the "OUT" position. **CAUTION: Do not operate vehicle over 10 miles per hour with front wheels engaged.**

## DRIVING CONTROLS AND OPERATION

(4) **STOPPING VEHICLE.** Close throttle by removing foot from the accelerator pedal. Apply service brake carefully as needed by depressing service brake pedal. When vehicle is about to stop, disengage clutch and move main transmission gearshift lever into neutral position. When truck is completely stopped, apply propeller shaft brake. Release clutch and service brake pedals.

(5) **STOPPING ENGINE.** To stop engine, turn ignition switch (fig. 3) to "OFF" position. Make sure switch is completely open, otherwise battery will be run down and starting engine will be difficult.

### 6. TOWING THE VEHICLE.

a. **Towing to Start Vehicle.** Attach towing cable to towing hooks. Place front axle declutch lever (fig. 3) in "OUT" position (fig. 4). Move transfer case shift lever to "HIGH" position (fig. 4). Shift main transmission gearshift lever to the No. 5 or overdrive position (fig. 4). Pull out choke, throttle, and spark controls into same position as for starting. Turn ignition switch to "ON" position. Release propeller shaft brake lever and depress clutch pedal. When a reasonable speed is reached, slowly release clutch. As soon as engine starts, disengage clutch and adjust controls, as necessary, to provide a smooth running engine. If it is necessary to stop the vehicle before the engine starts and air cannot be made available from the towing truck, use propeller shaft brake. Exercise extreme caution in applying this brake.

b. **Towing Disabled Vehicle.** Check tires for proper inflation to make towing easier (par. 136 b). Attach towing cable to towing hooks. Be sure towing cable is long enough to make harsh usage of brakes unnecessary. Connect air supply, if any, on towing vehicle to trailer connections behind front bumper. This will enable operator of disabled vehicle to use service brakes. Move the front axle declutch lever to the "OUT" position (fig. 4). Place main transmission gearshift lever in the "NEUTRAL" position (fig. 4). Push propeller shaft brake lever all the way down into the "OFF" position. If air supply is not connected, the propeller shaft brake provides the only possible means for stopping. Because this brake is extremely severe, utmost care must be observed in using it. If necessary to hoist front end of truck, attach lifting tackle to bumper. Use care in wrapping chain around bumper to avoid crushing air tubing. Use necessary blocking between tow truck and bumper to prevent vehicle from running into tow truck. If necessary to hoist rear of truck, wrap chain around the entire frame immediately in front of rear spring rear bracket. Be sure to get chain between spring and frame, so that frame will carry the load. Attach necessary blocking between tow truck and rear frame rail to prevent damage through collision. Straighten front wheels and clamp on the steering wheel to prevent turning.

## 4. TO 5-TON 4x4 TRACTOR TRUCK (FEDERAL)

## Section IV

## OPERATION UNDER UNUSUAL CONDITIONS

## 7. COLD WEATHER OPERATION.

a. **Purpose.** Operation of automotive equipment at subzero temperatures presents problems that demand special precautions and extra careful servicing from both operation and maintenance personnel, if poor performance and total functional failure are to be avoided.

b. **Gasoline.** Winter grade of gasoline is designed to reduce cold weather starting difficulties; therefore the winter grade fuel should be used in cold weather operation.

c. **Storage and Handling of Gasoline.** Due to condensation of moisture from the air, water will accumulate in tanks, drums, and containers. At low temperatures, this water will form ice crystals that will clog fuel lines and carburetor jets unless the following precautions are taken:

(1) Strain the fuel through filter paper, or any other type of strainer that will prevent the passage of water. **CAUTION:** *Gasoline flowing over a surface generates static electricity that will result in a spark, unless means are provided to ground the electricity. Always provide a metallic contact between the container and the tank, to assure an effective ground.*

(2) Keep tank full, if possible. The more fuel there is in the tank, the smaller the volume of air will be from which moisture can be condensed.

(3) Add  $\frac{1}{2}$  pint of denatured alcohol, grade 3, to the fuel tank each time it is filled. This will reduce the hazard of ice formation in the fuel.

(4) Be sure that all containers are thoroughly clean and free from rust before storing fuel in them.

(5) If possible, after filling or moving a container, allow the fuel to settle before filling fuel tank from it.

(6) Keep all openings of containers tight to prevent snow, ice, dirt, and other foreign matter from entering.

(7) Wipe all snow or ice from dispensing equipment and from around fuel tank filler cap before removing cap to refuel vehicle.

d. **Lubrication.**(1) **TRANSMISSION AND DIFFERENTIAL.**

(a) Universal gear lubricant, SAE 80, where specified on figures 5 and 6 or War Department Lubrication Guide, is suitable for temperatures as low as  $-20^{\circ}\text{F}$ . If consistent temperature below  $0^{\circ}\text{F}$ . is anticipated, drain the gear cases while warm and refill with grade 75 uni-

**OPERATION UNDER UNUSUAL CONDITIONS**

versal gear lubricant, which is suitable for operation at all temperatures below 0°F. If grade 75 universal gear lubricant is not available, SAE 80 universal gear lubricant diluted with the fuel used by the engine, in the proportion of one part fuel to six parts universal gear lubricant, may be used. Dilute make-up oil in the same proportion before it is added to gear cases.

(b) After engine has been warmed up, engage clutch and maintain engine speed at fast idle for 5 minutes, or until gears can be engaged. Put transmission in low (first) gear, and drive vehicle for 100 yards, being careful not to stall the engine. This will heat gear lubricants to the point where normal operation can be expected.

(2) **CHASSIS POINTS.** Lubricate chassis points with general purpose grease, No. 0.

(3) **STEERING GEAR HOUSING.** Drain housing, if possible, or use suction gun to remove as much lubricant as possible. Refill with universal gear lubricant, Grade 75, or, if not available, SAE 80 universal gear lubricant diluted with fuel used in the engine, in the proportion of one part fuel to six parts SAE 80 universal gear lubricant. Dilute make-up oil in the same proportion before it is added to the housing.

(4) **OILCAN POINTS.** For oilcan points where engine oil is prescribed for above 0°F., use light lubricating, preservative oil.

(5) **PRECAUTIONS.**

(a) Keep crankcase oil fluid by one of the following methods, listed in order of preference:

1. Keep vehicle in a heated enclosure when not in use.

2. After stopping engine, drain crankcase oil while still hot. Place warning tag in a conspicuous place in the cab to indicate crankcase is empty. Store oil in a warm place if possible; otherwise, heat oil before reinstalling.

3. Cover entire cab and engine section with tarpaulin. Place fire pots under tarpaulin about 3 hours before engine is to be started. A Primus, Van Prag, or other type blowtorch, and ordinary kerosene lanterns may be used. **CAUTION: Be careful in applying flame directly to oil pan.**

4. Do not move the vehicle from a warm place into subzero temperature, unless necessary.

5. Park vehicle without setting propeller shaft brake to avoid brake freezing. Block wheels to prevent rolling of vehicle, and keep a blowtorch handy to thaw frozen propeller shaft or service brakes.

6. Inspect vehicle frequently for broken screws, bolts or other metal parts, and for loosened nuts.

7. Dilute crankcase oil with gasoline, or with Diesel fuel in an emergency. Turn engine over several times to mix oil and diluent. After four or more hours of operation, redilute oil if vehicle is to be left standing unprotected for 3 or more hours. Use diluent for both original dilution and redilution as follows:

## 4- TO 5-TON 4x4 TRACTOR TRUCK (FEDERAL)

Temperature	Diluent	Quantity
0 F. to -20° F.	Gasoline	½ qt to each 4½ qt of engine oil
0 F. to -20° F.	Diesel fuel	½ qt to each 3½ qt of engine oil
Below -20° F.	Gasoline	1 qt to each 5 qt of engine oil
Below -20° F.	Diesel fuel	1 qt to each 4 qt of engine oil

NOTE: Presence of diluent increases engine oil consumption. Check oil level frequently.

## c. Protection of Cooling Systems.

(1) USE ANTIFREEZE COMPOUND. Protect the system with antifreeze compound (ethylene-glycol type) for operation below -132° F. The following instructions apply to use of new antifreeze compound.

(2) CLEAN COOLING SYSTEM. Before adding antifreeze compound, clean the cooling system, and completely free it from rust. If the cooling system has been cleaned recently, it may be necessary only to drain, refill with clean water, and again drain. Otherwise clean the system with cleaning compound.

(3) REPAIR LEAKS. Inspect all hose and replace if deteriorated. Inspect all hose clamps, plugs, and pet cocks, and tighten if necessary. Repair all radiator leaks before adding antifreeze compound. Correct all leakage of exhaust gas or air into the cooling system.

(4) ADD ANTIFREEZE COMPOUND. When the cooling system is clean and tight, fill the system with water to about one-third capacity. Then add antifreeze compound, using the proportion of antifreeze compound to the cooling system capacity indicated below. Protect the system to at least 10° F. below the lowest temperature expected to be experienced during the winter season.

## ANTIFREEZE COMPOUND CHART

(for 40-quart capacity cooling system)

Temperature	Antifreeze Compound (ethylene-glycol type)
-30° F.	5 qt
-20° F.	7½ qt
-10° F.	10 qt
0° F.	12½ qt
-10° F.	15 qt
-20° F.	17½ qt
-30° F.	20 qt
-40° F.	22½ qt
-50° F.	22½ qt
-60° F.	25 qt
-70° F.	25 qt

## OPERATION UNDER UNUSUAL CONDITIONS

(5) **WARM THE ENGINE.** After adding antifreeze compound, fill with water to slightly below the filler neck; then start and warm the engine to normal operating temperature.

(6) **TEST STRENGTH OF SOLUTION.** Stop the engine and check the solution with a hydrometer, adding antifreeze compound if required.

(7) **INSPECT WEEKLY.** In service, inspect the coolant weekly for strength and color. If rusty, drain and clean cooling system thoroughly, and add new solution of the required strength.

### (8) PRECAUTIONS.

(a) Antifreeze compound is the only antifreeze material authorized for ordnance materiel.

(b) It is essential that antifreeze solutions be kept clean. Use only containers and water that are free from dirt, rust, and oil.

(c) Use an accurate hydrometer. To test a hydrometer, use one part antifreeze compound to two parts water. This solution will produce a hydrometer reading of 0°F.

(d) Do not spill antifreeze compound on painted surfaces.

### f. Electrical Systems.

(1) **GENERATOR AND CRANKING MOTOR.** Check the brushes, commutators, and bearings. See that the commutators are clean. The large surges of current which occur when starting a cold engine require good contact between brushes and commutators.

(2) **WIRING.** Check, clean, and tighten all connections, especially the battery terminals. Be sure that no short circuits are present.

(3) **COIL.** Check coil for proper functioning by noting quality of spark.

(4) **DISTRIBUTOR.** Clean thoroughly, and clean or replace points. Check the points frequently. In cold weather, slightly pitted points may prevent engine from starting.

(5) **SPARK PLUGS.** Clean and adjust spark plugs or replace, if necessary. If it is difficult to make the engine fire, reduce the gap to 0.005 inch less than that recommended for normal operation (par. 83 c (2)). This will make ignition more effective at reduced voltages likely to prevail.

(6) **TIMING.** Check the timing carefully. Be sure that the spark is not unduly advanced nor retarded.

### (7) BATTERY.

(a) The efficiency of batteries decreases sharply with decreasing temperatures, and becomes practically nil at -40°F. Do not try to start the engine with the battery when it has been chilled to temperatures below -30°F., until battery has been heated, unless a warm slave battery is available. See that the battery is always fully charged, with the hydrometer reading between 1.275 and 1.300. A fully charged battery will not freeze at temperatures likely to be

**4- TO 5-TON 4x4 TRACTOR TRUCK (FEDERAL)**

encountered even in Arctic climates, but a fully discharged battery will freeze and rupture at  $-5^{\circ}\text{F}$ .

(b) Do not add water to a battery when it has been exposed to subzero temperatures unless the battery is to be charged immediately. If water is added and the battery not put on charge, the layer of water will stay at the top and freeze before it has a chance to mix with the acid.

(8) **LIGHTS.** Inspect the lights carefully. Check for short circuits and presence of moisture around sockets.

(9) **ICE.** Before every start, see that the spark plugs, wiring, or other electrical equipment are free from ice.

**g. Starting and Operating Engine.**

(1) **INSPECT CRANKING MOTOR MECHANISM.** Be sure that no heavy grease or dirt has been left on the cranking motor throw-out mechanism. Heavy grease or dirt is liable to keep the gears from being meshed, or cause them to remain in mesh after the engine starts running. The latter will ruin the cranking motor and necessitate repairs.

(2) **USE OF CHOKE.** A full choke is necessary to secure the rich air-fuel mixture required for cold weather starting. Check the butterfly valve to see that it closes all the way and otherwise functions properly.

(3) **CARBURETOR AND FUEL PUMP.** The carburetor, which will give no appreciable trouble at normal temperatures, is liable not to operate satisfactorily at low temperatures. Be sure the fuel pump has no leaky valves or diaphragm, as this will prevent the fuel pump from delivering the amount of fuel required to start the engine at low temperatures when running speeds are reduced to between 30 and 60 revolutions per minute.

(4) **AIR CLEANERS.** At temperatures below  $0^{\circ}\text{F}$ ., do not use oil in air cleaners. The oil will congeal and prevent the easy flow of air. Wash screens in dry-cleaning solvent, dry, and replace. Ice and frost formations on the air cleaner screens can cause an abnormally high intake vacuum in the carburetor air horn hose, resulting in collapse.

(5) **FUEL SYSTEM.** Remove and clean sediment bowl, strainers, etc., daily. Also drain fuel tank sump daily to remove water and dirt.

**h. Chassis.**

(1) **BRAKE BANDS.** Brake bands, particularly on new vehicles, have a tendency to bind when they are very cold. Always have a blowtorch handy to warm up these parts, if they bind prior to moving, or attempting to move, the vehicle. Parking the vehicle with the brake released will eliminate most of the binding. Precaution must be taken, under these circumstances, to block the wheels or otherwise prevent movement of the vehicle.



## OPERATION UNDER UNUSUAL CONDITIONS

(2) **EFFECT OF LOW TEMPERATURES ON METALS.** Inspect the vehicle frequently. Shock resistance of metals, or resistance against breaking, is greatly reduced at extremely low temperatures. Operation of vehicles on hard, frozen ground causes strain and jolting which will result in screws breaking, or nuts jarring loose.

(3) **SPEEDOMETER CABLE.** Disconnect the oil-lubricated speedometer cable at the drive end when operating the vehicle at temperatures of  $-30^{\circ}\text{F}$ . and below. The cable will often fail to work properly at these temperatures, and sometimes will break, due to the excessive drag caused by the high viscosity of the oil with which it is lubricated.

### 8. HOT WEATHER OPERATION.

a. **General.** Operation of these vehicles in high temperatures requires regular maintenance of cooling units, lubrication-filtering devices, and air cleaners. In extremely high temperatures, water-saving devices such as surge or overflow tanks should be employed. Avoid the continuous use of low gear ratios whenever possible. Make frequent inspections and servicing of air cleaners, fuel filter, and oil filter if side panels are removed during operation in dusty areas. Watch the temperature and oil gages constantly. Check and replenish oil and water frequently. **CAUTION:** *Inspect vehicle frequently for broken screws, bolts, or other metal parts, and for loosened nuts.*

#### b. Cooling System Maintenance.

(1) **COOLING LIQUID.** Formation of scale and rust in cooling system occurs more often during operation in extremely high temperatures; therefore rust preventives should always be added to the cooling liquids. Use only clean water. Avoid the use of water that contains alkali or other substances which may cause scale and rust formations.

(2) **COOLING SYSTEM.** Thoroughly clean and flush the cooling system at frequent intervals when operating in extremely high temperatures.

(3) **FAN BELT AND WATER PUMP.** Inspect fan belt at regular intervals and adjust if necessary (par. 78). Water pump must be kept in good operating condition.

(4) **THERMOSTAT.** Check operation of thermostat (par. 76). Thermostat must open at calibrated temperature to prevent overheating of cooling liquid.

(5) **HOSE CONNECTIONS.** Check hose connections frequently for leaks.

#### c. Hot, Dry Climates.

(1) Keep cooling system full of recommended coolant and maintain proper level of correct grade of lubricating oil in lubricating system. Check engine temperature frequently, and if temperature rises to  $212^{\circ}\text{F}$ ., stop engine and inspect cooling system. Flush

**4. TO 5-TON 4x4 TRACTOR TRUCK (FEDERAL)**

cooling system if necessary; look for sand in radiator fins; blow out with compressed air, if available.

(2) Under desert conditions, check oil filter, carburetor, air cleaner, and air compressor air filter every few hours, and service as necessary.

(3) Under sandy conditions, use lubricants sparingly and clean all sand from fittings before lubricating.

(4) Avoid touching machined surfaces when making repairs.

(5) Do not park vehicle in sun for long periods, because this shortens life of tires. If possible, place vehicle under cover to protect it from sand and dust. Cover inactive vehicles with tarpaulin if no suitable building is available.

**d. Hot, Damp Climates.**

(1) Keep cooling system clean and filled with clean fresh (not salt) water. Use soft water when possible. Note engine temperature as registered by temperature gage frequently. Stop vehicle immediately if temperature of engine reaches 212° F.

(2) Protect exterior surfaces from atmosphere by renewing paint on all painted surfaces, and keeping a film of light engine oil on unfinished exterior metal surfaces.

(3) Flush metal surfaces which have been exposed to salt water with fresh water, and apply a film of light engine oil to unfinished metal parts.

(4) Make frequent inspections of stored vehicles. Remove corrosion from exterior surfaces with flint paper 2.0 (from machined surfaces with crocus cloth), and apply a protective coating of paint, oil, or rust preventive compound.

**e. Battery.**

(1) **WATER LEVEL.** In torrid zones, cell water level should be checked daily and replenished if necessary with pure distilled water. If this is not available, any water fit to drink may be used. However, continuous use of water with high mineral content will eventually cause damage to battery and should be avoided.

(2) **SPECIFIC GRAVITY.** Batteries operating in torrid climates should have a weaker electrolyte than for temperate climates. Instead of 1.300 gravity, the electrolyte should be adjusted to around 1.210 to 1.230 for a fully charged battery. This will prolong the life of the negative plates and separators. Under this condition battery should be recharged at about 1.160. Where freezing conditions do not prevail, there is no danger with gravities from 1.230 to 1.075.

(3) **SELF-DISCHARGE.** A battery will "self-discharge" at a greater rate at high temperatures if standing for long periods. This must be taken into consideration when operating in torrid zones. If necessary to park for several days, remove battery and store in a cool place.

**FIRST ECHELON PREVENTIVE MAINTENANCE SERVICES****9. OPERATION IN MUD, SNOW, ICE, SAND, AND FLOOD.**

a. **Mud.** Install tire chains on both rear wheels, and select low enough gear ratio to move vehicle steadily without putting undue driving strain on engine and axles.

b. **Snow and Ice.** Skidding is the general hazard encountered in these conditions. Install chains, and select the proper gear ratio to move the vehicle steadily, without imposing undue strain on engine and axle. When skidding occurs, turn the front wheels, in the same direction that the rear end is skidding. Decelerate the engine, and apply brakes very gradually until vehicle is under control. Proceed with caution. Remove chains as soon as their use is no longer necessary.

c. **Sand.** The main objective when driving in sand is to avoid the possibility of spinning the driving wheels. If possible, lay an improvised track with planks or brush in order to prevent the wheels coming in contact with the loose footing. Do not let the motor labor. Reverse and go forward several times if necessary, until a solid roadbed is reached.

d. **Flood.** Know the fording depth of this vehicle, and do not exceed its known limits. Reduce the vehicle speed to 4 miles per hour and proceed with caution. Exercise care to avoid water damage to electrical and driving systems. Lubricated parts which have been affected by mud and water must be serviced at earliest opportunity.

e. **Precautions.** Do not allow mud, snow, or ice to cake on wheels, slack adjusters, steering knuckles, and steering arms, or to gather on the air system safety valve, oil filter, or air filter openings. Inspect and clean mud, snow, or ice off radiator core, fan, and fan belts. Keep mud, snow, ice, and moisture off all electrical connections.

**10. DECONTAMINATION.**

a. **Poisonous Gas.** Removing and destroying dangerous chemical agents encountered when operating in affected areas is known as decontamination and is covered by instructions contained in FM 17-59.

---

**Section V****FIRST ECHELON PREVENTIVE MAINTENANCE SERVICES****11. PURPOSE.**

a. To insure mechanical efficiency it is necessary that the vehicle be systematically inspected at intervals each day it is operated and weekly, so defects may be discovered and corrected before they

**4. TO 3-TON 4x4 TRACTOR TRUCK (FEDERAL)**

result in serious damage or failure. Certain scheduled maintenance services will be performed at these designated intervals. The services set forth in this section are those performed by driver or crew Before-operation, During-operation, At-halt, After-operation and weekly.

b. Driver preventive maintenance services are listed on the back of "Driver's Trip Ticket and Preventive Maintenance Service Record" W.D. Form No. 48 to cover vehicles of all types and models. Items peculiar to specific vehicles, but not listed on W.D. Form No. 48, are covered in manual procedures under the items to which they are related. Certain items listed on the form that do not pertain to the vehicle involved are eliminated from the procedures as written into the manual. Every organization must thoroughly school each driver in performing the maintenance procedures set forth in manuals whether they are listed specifically on W.D. Form 48 or not.

c. The items listed on W.D. Form No. 48 that apply to this vehicle are expanded in this manual to provide specific procedures for accomplishment of the inspections and services. These services are arranged to facilitate inspection and conserve the time of the driver and are not necessarily in the same numerical order as shown on W.D. Form No. 48. The item numbers, however, are identical with those shown on that form.

d. The general inspection of each item applies also to any supporting member or connection, and generally includes a check to see whether the item is in good condition, correctly assembled, secure, or excessively worn.

(1) The inspection for "good condition" is usually an external visual inspection to determine whether the unit is damaged beyond safe or serviceable limits. The term "good condition" is explained further by the following: Not bent or twisted, not chafed or burned, not broken or cracked, not bare or frayed, not dented or collapsed, not torn or cut.

(2) The inspection of a unit to see that it is "correctly assembled" is usually an external visual inspection to see if it is in its normal assembled position in the vehicle.

(3) The inspection of a unit to determine if it is "secure" is usually an external visual examination, a wrench, hand-feel, or a pry-bar check for looseness. Such an inspection should include any brackets, lock washers, lock nuts, locking wires, or cotter pins used in assembly.

(4) "Excessively worn" will be understood to mean worn close to, or beyond, serviceable limits, and likely to result in a failure if not replaced before the next scheduled inspection.

e. Any defects or unsatisfactory operating characteristics beyond the scope of first echelon to correct must be reported at the earliest opportunity to the designated individual in authority.

**FIRST ECHELON PREVENTIVE MAINTENANCE SERVICES****12. BEFORE-OPERATION SERVICE.**

a. This inspection schedule is designed primarily as a check to see that the vehicle has not been damaged, tampered with, or sabotaged since the After-operation Service was performed. Various combat conditions may have rendered the vehicle unsafe for operation and it is the duty of the driver to determine whether or not the vehicle is in condition to carry out any mission to which it is assigned. This operation will not be entirely omitted, even in extreme tactical situations.

b. **Procedures.** Before-operation Service consists of inspecting items listed below according to the procedure described, and correcting or reporting any deficiencies. Upon completion of the service, results should be reported promptly to the designated individual in authority.

(1) **ITEM 1, TAMPERING AND DAMAGE.** Look for any injury to vehicle, its accessories or equipment, caused by tampering or sabotage, collision, falling debris, or shell fire since parking. Look in engine compartment for evidence of above conditions, and for loosened or damaged engine accessories or drive belts, loose fuel, oil or coolant lines, or disconnected control linkage.

(2) **ITEM 2, FIRE EXTINGUISHER.** See that it is securely mounted and not damaged, and look for evidence of opened operating valve or leakage.

(3) **ITEM 3, FUEL, ENGINE OIL, AND COOLANT SUPPLY.** Check amount of fuel in tank. Check crankcase oil level on dip stick. Check coolant level. If necessary add fuel to complete mission or to operate vehicle to next scheduled fueling point. Add engine oil and coolant as needed to bring to correct level. *NOTE: Any appreciable drop in levels since After-operation Service should be investigated, and cause corrected or reported. During freezing weather when antifreeze solution is in use, if any appreciable addition of water is needed, antifreeze value should be tested by second echelon and added if necessary. Be sure spare fuel, oil, and water cans are full and securely mounted.*

(4) **ITEM 4, ACCESSORIES AND DRIVES.** Examine units, such as carburetor, generator, cranking motor, air compressor, fan, and air cleaners for looseness, damage or leaks. Be sure drive belts are in good condition and that adjustment is satisfactory. Belts should have  $\frac{1}{2}$ - to  $\frac{3}{4}$ -inch finger pressure deflection.

(5) **ITEM 5, AIR-BRAKE TANKS.** Check the air-brake reservoir tanks to see that they are secure and undamaged; and that all air line connections are tight. Also be sure that water (condensation) has been drained from the tanks and that pet cocks are closed.

(6) **ITEM 6, LEAKS, GENERAL.** Inspect ground and under vehicle and within engine compartment for indications of fuel, engine oil,

## 4- TO 5-TON 4x4 TRACTOR TRUCK (FEDERAL)

coolant, and gear oil leaks. Pay particular attention to fuel tanks and lines, crankcase and oil filters, radiator, water pump, water lines, and connections, and all gear cases. Trace any leaks found to their source, and correct or report them.

(7) **ITEM 7, ENGINE WARM-UP.** Start engine and note any tendency toward hard starting. Observe action of cranking motor particularly if it has adequate cranking speed, and engages and disengages without unusual noise when in operation. Set hand throttle to idle engine at about 750 revolutions per minute, and during warm-up proceed with following Before-operation Services. **NOTE:** *If oil pressure is not evident in 30 seconds, stop engine and investigate.*

(8) **ITEM 8, CHOKE.** As engine is being started, check operation of choke. As engine warms up, reset choke as required for engine to run smoothly and to prevent overchoking and oil dilution.

(9) **ITEM 9, INSTRUMENTS.**

(a) **Oil Gage.** Pressure at normal engine operating speed should be about 26 pounds.

(b) **Ammeters.** Regular ammeter should show positive (+) charge with engine at fast idle, and at slower speeds with lights on may show on negative (-) side. "B" ammeter indicates that second battery or "B" battery is charging or discharging. High charge readings may be indicated until generator restores to batteries current used in starting engine.

(c) **Engine Temperature Gage.** Reading should increase gradually during warm-up period to normal operating range 140° F. to 160° F. Maximum safe temperature 200° F. **NOTE:** *Do not move vehicle until temperature reaches minimum operating range, 135° F.*

(d) **Viscometer.** After engine has reached operating temperature reading should be in "ideal" range.

(e) **Tachometer.** White pointer should indicate actual engine revolutions per minute at any given time engine is running. Red hand indicates and remains at highest engine revolutions per minute reached which should not exceed 2,300 revolutions per minute.

(f) **Air Pressure Gage.** Gage should register 60 pounds before vehicle is moved. Low pressure indicator "buzzer" should sound at pressure below 60 pounds and cut-out above 60 pounds. Maximum governed pressure is 105 pounds.

(g) **Fuel Gage.** Inspect to see that gage registers the approximate amount of fuel in tank. Ordinarily tank will be filled after operation and gage should register "full."

(10) **ITEM 10, HORN AND WINDSHIELD WIPERS.** If tactical situation permits, test horn for proper operation and tone. Test wipers to see that they operate, and observe whether the blades contact glass evenly and arms travel through full stroke. Inspect for damage.

(11) **ITEM 11, GLASS AND REAR-VISION MIRROR.** Clean all glass

**FIRST ECHELON PREVENTIVE MAINTENANCE SERVICES**

and inspect for damage. Aim rear vision mirror properly and see that it is secure.

(12) **ITEM 12, LAMPS (LIGHTS) AND REFLECTORS.** See that all lights and warning reflectors are clean. Examine them for looseness or damage. If tactical situation permits, open and close switches and observe if lights respond properly. Include stop and blackout lights.

(13) **ITEM 13, WHEEL AND FLANGE NUTS.** See that all wheel mounting, and axle flange nuts are present and secure.

(14) **ITEM 14, TIRES.** Pressure 65 pounds (maximum) cool. Inspect tires for damage, and remove any imbedded objects from treads, carcass, or between duals.

(15) **ITEM 15, SPRINGS AND SUSPENSIONS.** Inspect springs and shock absorbers to see that they are secure and not damaged, and that all assembly and mounting nuts and screws are tight. Examine shocks for leaks.

(16) **ITEM 16, STEERING LINKAGE.** Inspect gear case and all rods and points for looseness, damage, or excessive lubricant leaks.

(17) **ITEM 17, FENDERS AND BUMPERS.** Inspect for looseness or damage.

(18) **ITEM 18, TOWING CONNECTIONS.** Inspect for looseness or damage. Examine pintle to be sure it operates freely and locks securely.

(19) **ITEM 19, BODY AND TARPULIN.** Inspect cab and top tarpaulin for damage. See that doors and latches operate properly, and that floor plates and engine cover are secure.

(20) **ITEM 20, DECONTAMINATOR.** Be sure it is present, fully charged and secure.

(21) **ITEM 21, TOOLS AND EQUIPMENT.** Be sure all items are present, serviceable, and properly mounted or stowed.

(22) **ITEM 22, ENGINE OPERATION.** Before vehicle is put in motion, be sure engine has reached operating temperature and idles smoothly. Accelerate and decelerate and listen for any unusual vibration or noise. Note any unsatisfactory operating characteristics or excessive exhaust smoke.

(23) **ITEM 23, DRIVER'S PERMIT AND FORM 26.** Driver must have his operator's permit on his person. Check to see that Accident Form No. 26, operator's manual, and lubrication guide are present in vehicle, legible, and properly stowed.

(24) **ITEM 25, DURING-OPERATION CHECK.** The During-operation Services and observations start immediately after the vehicle is put in motion as follows.

**13. DURING-OPERATION SERVICE.**

a. While vehicle is in motion, listen for any sounds such as rattles, knocks, squeals, or hums that may indicate trouble. Look for indications of trouble in cooling system and smoke from any part



**4- TO 5-TON 4x4 TRACTOR TRUCK (FEDERAL)**

of the vehicle. Be on the alert to detect any odor of overheated components or units such as generator, brakes or clutch, fuel vapor from a leak in fuel system, exhaust gas or other signs of trouble. Any time the brakes are used, gears shifted, or vehicle turned consider this a test and notice any unsatisfactory or unusual performance. Watch the instruments constantly. Notice promptly any unusual instrument indication that may signify possible trouble in system to which the instrument applies.

b. **Procedures.** During-operation Services consist of observing items listed below according to the procedures following each item, and investigating any indications of serious trouble. Notice minor deficiencies to be corrected or reported at earliest opportunity, usually next scheduled halt.

(1) **ITEM 27, FOOT AND HAND BRAKES.** Foot brakes should stop vehicle smoothly and effectively with normal pedal pressure, and return to "OFF" position immediately foot pressure is released. If towed vehicle is connected, test hand operated air application valve separately and note if brake action on trailer is satisfactory. Hand brake should hold vehicle on a reasonable incline, leaving 1/2 ratchet travel in reserve, and should lock securely in applied position.

(2) **ITEM 28, CLUTCH.** Clutch should not grab, chatter, or squeal during engagement, or slip when fully engaged under load. Pedal should have 1 1/2-inch free travel before meeting resistance.

(3) **ITEM 29, TRANSMISSION.** Gears should shift smoothly and quietly, and not creep out of mesh during operation.

(4) **ITEM 30, TRANSFER.** Transfer unit range gears and declutching mechanism should shift easily and quietly and not creep out of mesh during operation.

(5) **ITEM 31, ENGINE AND CONTROLS.** The driver must be on the alert for deficiencies in engine performance such as lack of usual power, misfiring or stalling, unusual noise or vibration, indications of overheating or excessive exhaust smoke. Observe if engine responds to all controls and if controls appear to be in proper adjustment, and not excessively loose or binding.

(6) **ITEM 32, INSTRUMENTS.** Observe readings of all instruments frequently during operation to be sure units to which they apply are functioning satisfactorily.

(a) *Oil Pressure Gage.* Reading should show normal operating pressure, about 40 pounds.

(b) *Ammeters.* During operation with all lamps and accessories turned off the main ammeter should indicate a positive ( + ) charge at operating speed or with fully charged batteries and regulator unit cut in may register zero. "B" ammeter should also show positive ( + ) or zero charge. Investigate or report excessive negative ( - ) readings.

(c) *Engine Temperature Gage.* Reading should increase gradually during warm-up to normal operating temperature, 160° F.

**FIRST ECHELON PREVENTIVE MAINTENANCE SERVICES**

**CAUTION:** Do not move vehicle until engine temperature has reached 135 F. Maximum safe temperature 200 F.

(d) *Viscometer.* During operation viscometer pointer should remain in "ideal" range. Thin range reading may indicate oil dilution. Heavy range reading may indicate oil contamination such as presence of dirt or sludge. Abnormal readings should be investigated or reported.

(e) *Air Pressure Gage.* Maximum reading should be 105 pounds, minimum 60 pounds.

(f) *Tachometer.* White pointer should register actual engine revolutions per minute and red pointer should not exceed maximum governed speed, 2,300 revolutions per minute.

(g) *Speedometer.* Pointer should indicate actual vehicle speed and odometer should register total accumulating mileage.

(h) *Fuel Gage.* Fuel gage should continue to register approximate amount of fuel in tank.

(7) **ITEM 33, STEERING GEAR.** Note any indication of looseness or binding, pull to one side, wandering, shimmy, wheel tramp, or unusual noise.

(8) **ITEM 34, RUNNING GEAR.** Be on alert for any unusual operating characteristics or noise from wheels, axles, or suspension units that might indicate looseness or damage, or underinflated tires.

(9) **ITEM 35, BODY.** Note any noise or abnormal condition that might indicate shifting, loose top tarpaulin or curtains, loose or damaged doors, hardware, floor or inspection plates or mounted body attachments.

**14. AT-HALT SERVICE.**

a. At-halt Services may be regarded as minimum maintenance procedures and should be performed under all tactical conditions even though more extensive maintenance services must be slighted or omitted altogether.

b. **Procedures.** At-halt Services consist of investigating any deficiencies noted during operation, inspecting items listed below according to the procedures following the items, and correcting any deficiencies found. Deficiencies not corrected should be reported promptly to the designated individual in authority.

(1) **ITEM 38, FUEL, OIL AND WATER SUPPLY.** Check the fuel supply to see that it is adequate to operate the vehicle to the next refueling point. When refueling, use safety precautions for grounding static electricity, and allow space for expansion in filler neck. Filler-cap vents must be open, pressure cap valves must be free and caps must be replaced securely. Check the crankcase oil level and, if necessary, add oil to proper level. Remove radiator filler cap being careful of steam, especially if a pressure cap is used and check coolant to see that it is at proper level, and replenish as necessary. Do not

**4- TO 5-TON 4x4 TRACTOR TRUCK (FEDERAL)**

fill to overflowing but leave sufficient space for expansion. If engine is hot, fill slowly while engine is running at a fast idle.

(2) **ITEM 39, TEMPERATURES: HUBS, BRAKE DRUMS, TRANSFER, TRANSMISSION, AND AXLES.** Place hand cautiously on each brake drum and wheel hub to see if it is abnormally hot. Inspect transfer case, transmission, and axle housings for overheating and note any excessive lubricant leaks.

(3) **ITEM 40, AXLE AND TRANSFER VENTS.** Wipe clean and inspect vents for damage or clogging. Vents must be kept open.

(4) **ITEM 41, PROPELLER SHAFTS.** Inspect all drive shafts and U-joints for looseness, damage, and excessive lubricant leaks. Remove any foreign matter wound around shafts or joints.

(5) **ITEM 42, SPRINGS AND SUSPENSIONS.** Inspect for broken or shifted spring leaves, damaged or loose U-bolts, eyebolts, shackles, rebound clips or shock absorber bodies and linkage, or excessive shock fluid leaks.

(6) **ITEM 43, STEERING LINKAGE.** Examine all steering control mechanism, arms, and linkage frictional joints for looseness or damage. Investigate any unusual condition noted during operation.

(7) **ITEM 44, WHEEL AND FLANGE NUTS.** See that all wheel mounting and axle flange nuts are present and secure.

(8) **ITEM 45, TIRES.** Inspect all tires for under inflation or damage. Remove embedded objects in treads or carcasses and from between duals. See that spare is inflated and secure in carrier.

(9) **ITEM 46, LEAKS—GENERAL.** Look under vehicle and within engine compartment for indication of fuel, oil or coolant leaks. Trace any found to their source and correct or report them.

(10) **ITEM 47, ACCESSORIES AND BELTS.** Examine all accessible units for looseness or damage. Be sure generator, fan, and compressor drive belt tension is satisfactory. If radio noise contributable to operation of this engine was observed, examine all radio noise suppression devices for looseness and damage, particularly resistor-suppressors on spark plugs and distributor. See paragraphs 181-185 for locations.

(11) **ITEM 48, AIR CLEANERS.** If operating under extremely dusty or sandy conditions, inspect air cleaner and breather cap to see that they are in condition to deliver clean air properly. Service as necessary.

(12) **ITEM 49, FENDERS AND BUMPER.** Inspect front bumper and fenders and rear splash guards for looseness or damage.

(13) **ITEM 50, TOWING CONNECTIONS.** Inspect all connections for looseness or damage. Be sure locking devices are secure, and that trailer brake air hose is supported so as not to chafe on other vehicle parts.

(14) **ITEM 51, BODY AND TARPAULIN.** Inspect for damage, or indications of looseness or shifting of cab.

### FIRST ECHELON PREVENTIVE MAINTENANCE SERVICES

(15) **ITEM 52, GLASS.** Clean all windshield, mirror, light, and warning reflector glass and inspect for damage.

#### 15. AFTER-OPERATION AND WEEKLY SERVICE.

a. After-operation Servicing is particularly important because at this time the driver inspects his vehicle to detect any deficiencies that may have developed and corrects those he is permitted to handle. He should report promptly, to the designated individual in authority the results of his inspection. If this schedule is performed thoroughly, the vehicle should be ready to roll again on a moment's notice. The Before-operation Service, with a few exceptions, is then necessary only to ascertain if the vehicle is in the same condition in which it was left upon completion of the After-operation Service. The After-operation Service should never be entirely omitted even in extreme tactical situations, but may be reduced to the bare fundamental services outlined for the At-halt Service if necessary.

h. **Procedures.** When performing the After-operation Service the driver must remember and consider any irregularities noticed during the day in the Before-operation, During-operation, and At-halt Services. The After-operation Service consists of inspecting and servicing the following items. Those items of the After-operation Services that are marked by an asterisk (\*) require additional weekly services, the procedures for which are indicated in subparagraph (b) of each applicable item.

(1) **ITEM 55, ENGINE OPERATION.** Test engine for satisfactory performance and smooth idle. Accelerate and decelerate engine and note any tendency to miss or backfire. Listen for any unusual noise or vibration that may indicate worn or inadequately lubricated parts, loose mountings, incorrect fuel mixture, or faulty ignition. Note any unusual exhaust smoke. Investigate and correct or report any deficiencies noted during operation.

(2) **ITEM 56, INSTRUMENTS.** Check all pertinent instruments to be sure all are operating properly and continue to register or indicate correct performance of the units to which they apply. Stop engine, allowing it to cool off for four or five minutes if it is at or beyond normal temperature.

(3) **ITEM 54, FUEL, OIL AND WATER SUPPLY.** Fill fuel tanks: (See if fuel gage indicates full.) Check crankcase oil and add as necessary to bring to correct level. Check coolant level and add as necessary to bring to correct level. *NOTE: Do not overfill fuel tanks or radiator. Allow room for expansion. In freezing weather if any appreciable amount of coolant is necessary have antifreeze value checked and add sufficient to protect cooling system against freezing. Do not add coolant while engine is too hot. Fill all spare fuel, oil and water cans if supply has been used.*

(4) **ITEM 57, HORN AND WINDSHIELD WIPERS.** Inspect to see if

**4- TO 5-TON 4x4 TRACTOR TRUCK (FEDERAL)**

these items are secure and not damaged. If tactical conditions permit, test horn for proper operation and tone.

(5) **ITEM 58, GLASS AND REAR VISION MIRROR.** Clean and inspect for damage and see that mountings are secure.

(6) **ITEM 59, LAMPS (LIGHTS) AND REFLECTORS.** Inspect for looseness or damage. If tactical situation permits, test all lights and switches for proper operation. Clean lenses.

(7) **ITEM 60, FIRE EXTINGUISHER.** Inspect for looseness or damage and full charge. If extinguisher has been in use or valves opened, report for refill or exchange.

(8) **ITEM 61, DECONTAMINATOR.** Inspect for looseness or damage and full charge. If used, report for refill or exchange.

(9) **ITEM 62, \*BATTERIES.**

(a) Inspect batteries to see that they are clean, secure, and not leaking or damaged. See that cell caps are fingertight.

(b) *Weekly.* Clean dirt from top of batteries. If terminal connections or posts are corroded, clean them thoroughly and apply fresh, thin coating of grease. Tighten terminal bolts if loose. Remove vent caps and check level of electrolyte. Add water if required, taking precautions so that battery will not be damaged during freezing temperatures. Battery should be secure, not bulging or cracked or leaking electrolyte; battery carrier should be secure, clean, free of rust, and well painted. If mountings are loose, tighten them cautiously so as not to damage the battery case. Report any defects.

(10) **ITEM 63, ACCESSORIES AND BELTS.** Inspect units such as carburetor, generator, cranking motor, fan, water pump, compressor, distributor, regulator unit and oil filters, for looseness, damage or leaks. Check condition and adjustment of drive belts. Should have  $\frac{1}{2}$  to  $\frac{3}{4}$  inch finger pressure deflection. Investigate and correct or report any deficiencies of accessory units or drives noted during operation.

(11) **ITEM 64, ELECTRICAL WIRING.** Inspect all ignition wiring for looseness or damage, wipe off excessive grease or moisture. Also make an inspection of all accessible low-voltage wiring and connections for looseness or damage and be sure all wiring is supported, so as not to chafe against other vehicle parts. Examine all radio noise suppression devices, paragraphs 181-185, for loose mountings or connections and tighten as necessary.

(12) **ITEM 65, \*AIR CLEANER AND BREATHER CAPS.**

(a) Inspect for looseness or damage. Examine oil in reservoirs for correct level and excessive dirt. When operating in sandy or dusty conditions, clean and service air cleaner and breather cap as often as necessary.

(b) *Weekly.* Remove air cleaner and breather reservoirs and elements, wash in dry-cleaning solvent, refill reservoirs with clean oil

**FIRST ECHELON PREVENTIVE MAINTENANCE SERVICES**

and reinstall securely. Be sure all gaskets seal properly and that joints and connections are secure.

**(13) ITEM 66, \*FUEL FILTER.**

(a) Inspect for looseness, damage and fuel leaks.

(b) *Weekly.* Remove sediment bowl drain plug and drain off all accumulated dirt and water. If draining of fuel pump sediment bowl shows excessive dirt or water, remove and clean element in dry-cleaning solvent.

(14) **ITEM 67, ENGINE CONTROLS.** Examine all engine operating control linkage for looseness, damage, excessive wear, and adequate lubrication.

**(15) ITEM 68, TIRES.**

(a) Examine all tires including spares for damage and excessive wear. Remove all embedded foreign matter, such as nails, glass, or stones, from treads and carcasses and from between duals. Check for low pressures and proper position of valve stem and presence of valve caps. Inflate to correct pressure as needed—65 pounds (maximum) cool.

(b) *Weekly.* Replace badly worn or otherwise unserviceable tires. Serviceable tires which show abnormal wear should be relocated to other wheels to even wear. Apparent mechanical deficiencies causing such wear should be reported for attention by higher echelon.

(16) **ITEM 69, SPRINGS AND SUSPENSIONS.** Inspect for looseness or damage, abnormal spring sag, shifted spring leaves, and shock absorber leakage. Investigate any noise or unusual condition noted during operation.

(17) **ITEM 70, STEERING LINKAGE.** Inspect for looseness or damage. Examine steering gear case and frictional joints for excessive lubricant leakage, or lack of lubrication. Investigate any unusual operating conditions noted during operation.

(18) **ITEM 71, PROPELLER SHAFTS.** Inspect all drive shafts and U-joints for looseness or damage and excessive oil leaks. Remove any foreign material wound around shafts or joints.

**(19) ITEM 72, \*AXLE AND TRANSFER VENTS.**

(a) See that all axle housing and transfer case vents are present, in good condition and clean. Inspect for indications of lubricant leakage from vents.

(b) *Weekly.* Remove vents and clean out passages. Reinstall securely.

(20) **ITEM 73, LEAKS—GENERAL.** Look in engine compartment and under vehicle for indications of fuel, engine oil, coolant, or gear oil leaks.

(21) **ITEM 74, GEAR OIL LEVELS.** Check gear oil levels in differentials, transfer case, transmission and steering gear housing, and report if low. Correct levels are from lower edge of filler hole to  $\frac{1}{2}$  inch below when cool.

## 4. TO 5-TON 4x4 TRACTOR TRUCK (FEDERAL)

## (22) ITEM 75, \*AIR BRAKE TANKS.

(a) Inspect tanks and lines for looseness or damage. Open reservoir drain cocks and drain off all accumulated condensate.

(b) *Weekly.* Tighten tank mountings and line connections. Clean air line rubber hose of all grease or oil.

(23) ITEM 76, FENDERS AND BUMPERS. Inspect front fenders and bumper and rear splash guards for looseness or damage.

## (24) ITEM 77, \*TOWING CONNECTIONS.

(a) Inspect towing hooks, truck tractor fifth wheel (if used) or pintle hook and safety chains for looseness, excessive wear or damage.

(b) *Weekly.* Lower trailer landing gear, if connected, and unhitch trailer. Clean contacting surfaces of fifth wheel plate, and kingpin latch mechanism. Inspect them for wear and damage, and apply a fresh coating of clean grease. Rehitch the trailer, noticing whether the hand lever works easily and whether the latching mechanism closes completely and latches securely.

(25) ITEM 78, BODY AND TARPAULIN. Inspect cab carefully for damage or loose parts. Examine top tarpaulin and side curtains for worn spots or other damage, and see that they are secure.

## (26) ITEM 82, \*TIGHTENING.

(a) Tighten any mounting or external assembly nuts or screws where inspection of vehicle has indicated the necessity.

(b) *Weekly.* Tighten wheel mounting and axle flange nuts and cap screws; spring U-bolts, eyebolts, shackles and rebound clips; U-joint companion flanges; engine mountings, transfer case mountings; steering arms, towing connections, or any other mounting or assembly nuts or screws that inspection or experience indicates are necessary on a weekly or mileage basis.

## (27) ITEM 83, \*LUBRICATE AS NEEDED.

(a) Lubricate all items such as shackles, hinges, latches, control linkage frictional joints, or any point where inspection has indicated oilcan or hand greasing is needed.

(b) *Weekly.* Lubricate all points of the vehicle indicated on the lubrication guide as needing lubrication on a weekly or a mileage basis.

## (28) ITEM 84, \*CLEAN ENGINE AND VEHICLE.

(a) Clean dirt and grease or oil drippings from inside cab, and from engine compartment and exterior of engine. Wipe off excess dirt and grease from entire vehicle.

(b) *Weekly.* Wash vehicle when possible. If not possible, wipe off thoroughly. Inspect paint or camouflage pattern for rust or for bright spots which might cause light reflections. See that vehicle markings are legible unless covered for tactical reasons. **CAUTION:** *If vehicle is driven into water for washing, care must be taken to see that water or dirt does not get into wheel bearings, gear cases or brakes, or on electrical units or wiring.*

## LUBRICATION

### (29) ITEM 85, \*TOOLS AND EQUIPMENT.

(a) Check vehicle stowage and tool lists (par. 1B), to see that all items are present. Inspect items to see that they are in good condition and properly mounted or stowed.

(b) *Weekly.* Clean all tools and equipment of rust or dirt, and apply preservative where necessary when possible. See that tools with cutting edge are sharp and properly protected and that all items are securely mounted or stowed. *NOTE: When services are completed, be sure all inspection plates are replaced securely.*

---

## Section VI

## LUBRICATION

### 16. LUBRICATION GUIDE.

a. War Department Lubrication Guide (fig. 6) prescribes lubrication maintenance for 4- to 5-ton tractor truck (Federal). Localized lubrication points are illustrated in figures 7, 8, 9, and 10.

b. A lubrication guide is placed on or is issued with each vehicle and is to be carried with it at all times. In the event the vehicle is received without a guide, the using arms shall immediately requisition a replacement from the Commanding Officer, Fort Wayne Ordnance Depot, Detroit, 32, Mich.

c. Lubrication instructions on the guide are binding on all echelons of maintenance and there shall be no deviations from these instructions.

d. Service intervals specified on the guide are for normal operation conditions. Reduce these intervals under extreme conditions such as excessively high or low temperatures, prolonged periods of high speed, continued operation in sand or dust, immersion in water, or exposure to moisture, any one of which may quickly destroy the protective qualities of the lubricant and require servicing in order to prevent malfunctioning or damage to the materiel.

e. Lubricants are prescribed in the "Key" in accordance with three temperature ranges; above +32° F., -32° F. to 0° F., and below 0° F. Determine the time to change grades of lubricants by maintaining a close check on operation of the vehicle during the approach to change-over. Be particularly observant when starting the engine. Sluggish starting is an indication of thickened lubricants and the signal to change to grades prescribed for the next lower temperature range. Ordinarily it will be necessary to change grades of lubricants *only when air temperatures are consistently in the next higher or lower range*, unless malfunctioning occurs sooner due to lubricants being too thin or too heavy.



4- TO 5-TON 4x4 TRACTOR TRUCK (FEDERAL)

MANUFACTURER'S SERIAL NUMBER located at front of frame on left side.

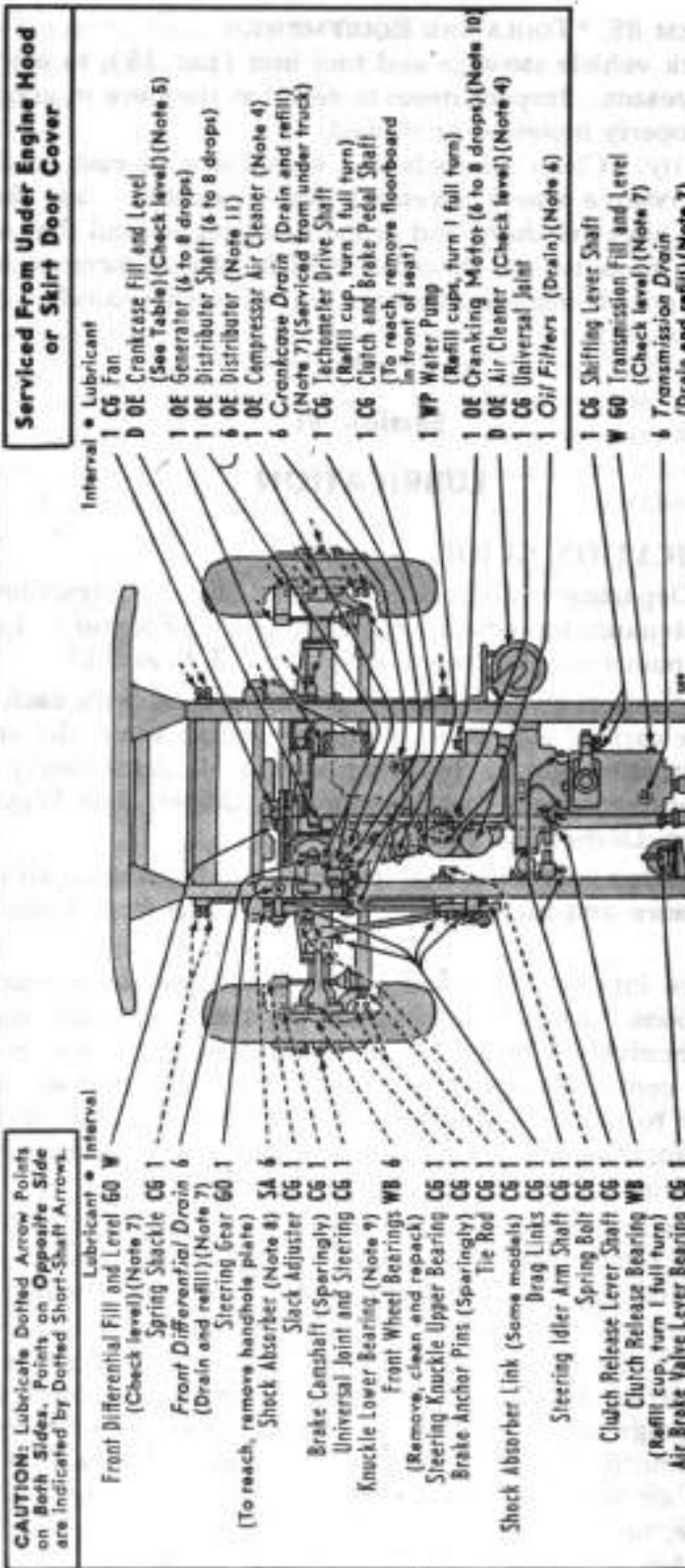

**CAUTION:** Lubricate Dotted Arrow Points on Both Sides, Points on Opposite Side are Indicated by Dotted Short-Shaft Arrows.

- Lubricant • Interval**
- Front Differential Fill and Level (Check level)(Note 7) **W**
  - Spring Shackle **CG 1**
  - Front Differential Drain (Drain and refill)(Note 7) **6**
  - Steering Gear **60 1**
  - (To reach, remove handhole plate)
  - Shock Absorber (Note 8) **SA 6**
  - Slack Adjuster **CG 1**
  - Brake Camshaft (Sparingly) **CG 1**
  - Universal Joint and Steering **CG 1**
  - Knuckle Lower Bearing (Note 9) **CG 1**
  - Front Wheel Bearings **WB 6**
  - (Remove, clean and repack)
  - Steering Knuckle Upper Bearing **CG 1**
  - Brake Anchor Pins (Sparingly) **CG 1**
  - Tie Rod **CG 1**
  - Shock Absorber Link (Some models) **CG 1**
  - Drag Links **CG 1**
  - Steering Idler Arm Shaft **CG 1**
  - Spring Bolt **CG 1**
  - Clutch Release Lever Shaft **CG 1**
  - Clutch Release Bearing **WB 1**
  - (Refill cup, turn 1 full turn)
  - Air Brake Valve Lever Bearing **CG 1**

**Serviced From Under Engine Hood or Skirt Door Cover**

- Interval • Lubricant**
- CG** Fan
  - D 0E** Crankcase Fill and Level (See Table)(Check level)(Note 5)
  - 1 0E** Generator (6 to 8 drops)
  - 1 0E** Distributer Shaft (6 to 8 drops)
  - 6 0E** Distributor (Note 11)
  - 1 0E** Compressor Air Cleaner (Note 4)
  - 6** Crankcase Drain (Drain and refill)(Note 7)(Serviced from under truck)
  - 1 0E** Tachometer Drive Shaft (Refill cup, turn 1 full turn)
  - 1 0E** Clutch and Brake Pedal Shaft (To reach, remove floorboard in front of seat)
  - 1 WP** Water Pump (Refill cups, turn 1 full turn)
  - 1 0E** Cranking Motor (6 to 8 drops)(Note 10)
  - D 0E** Air Cleaner (Check level)(Note 4)
  - 1 0E** Universal Joints
  - 1** Oil Filters (Drain)(Note 6)
  - 1 0E** Shifting Lever Shaft
  - W 60** Transmission Fill and Level (Check level)(Note 7)
  - 6** Transmission Drain (Drain and refill)(Note 7)

DA PD 328238

LUBRICATION

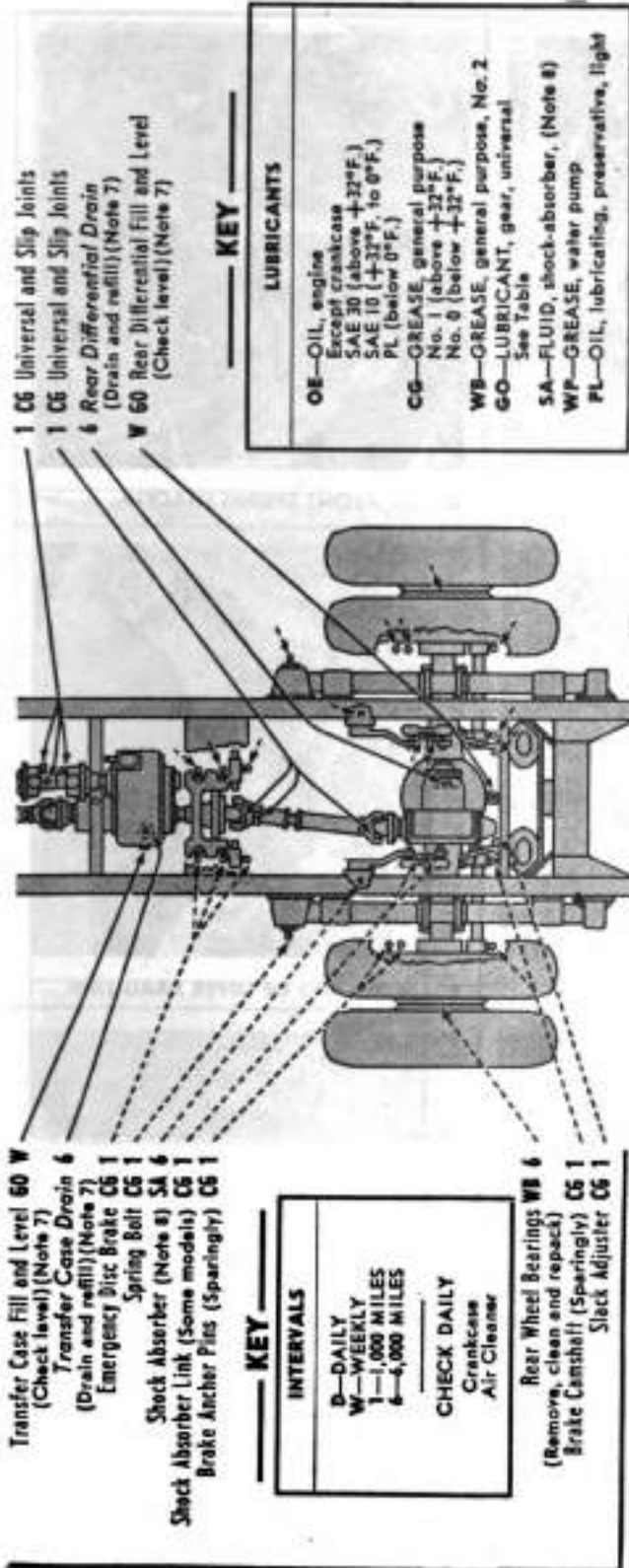

TABLE OF CAPACITIES AND LUBRICANTS TO BE USED

UNIT	CAPACITY (Approx.)	LOWEST EXPECTED AIR TEMPERATURE		
		+32° F. and above	+32° F. to 0° F.	Below 0° F.
Crankcase	14 qt.	OE SAE 30	OE SAE 10	Refer to OFSB 6-11
Transmission	10 qt.			
Transfer Case	2 qt.		GO SAE 90	GO Grade 75
Front and Rear Differentials (each unit)	6 qt.		GO SAE 90	GO Grade 75

10-20-43,  
Supersedes all previous instructions.

DA PB 328238

Figure 6 — Lubrication Guide, TRUCK, Tractor, 4- to 5-ton, 4 x 4, C.O.E. (Federal Model 94X43C)

4- TO 5-TON 4x4 TRACTOR TRUCK (FEDERAL)

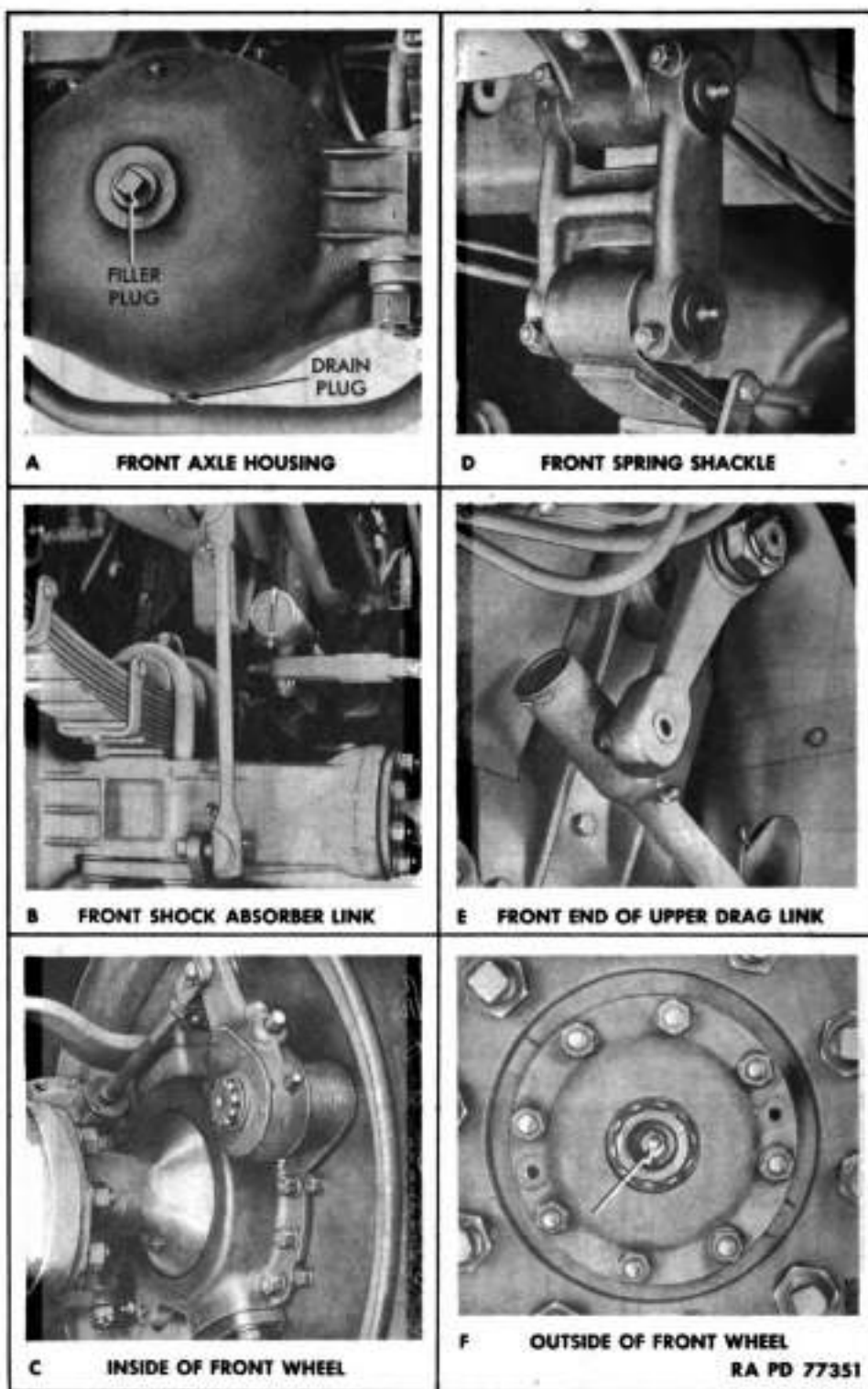

Figure 7 - Lubrication Points - A

LUBRICATION

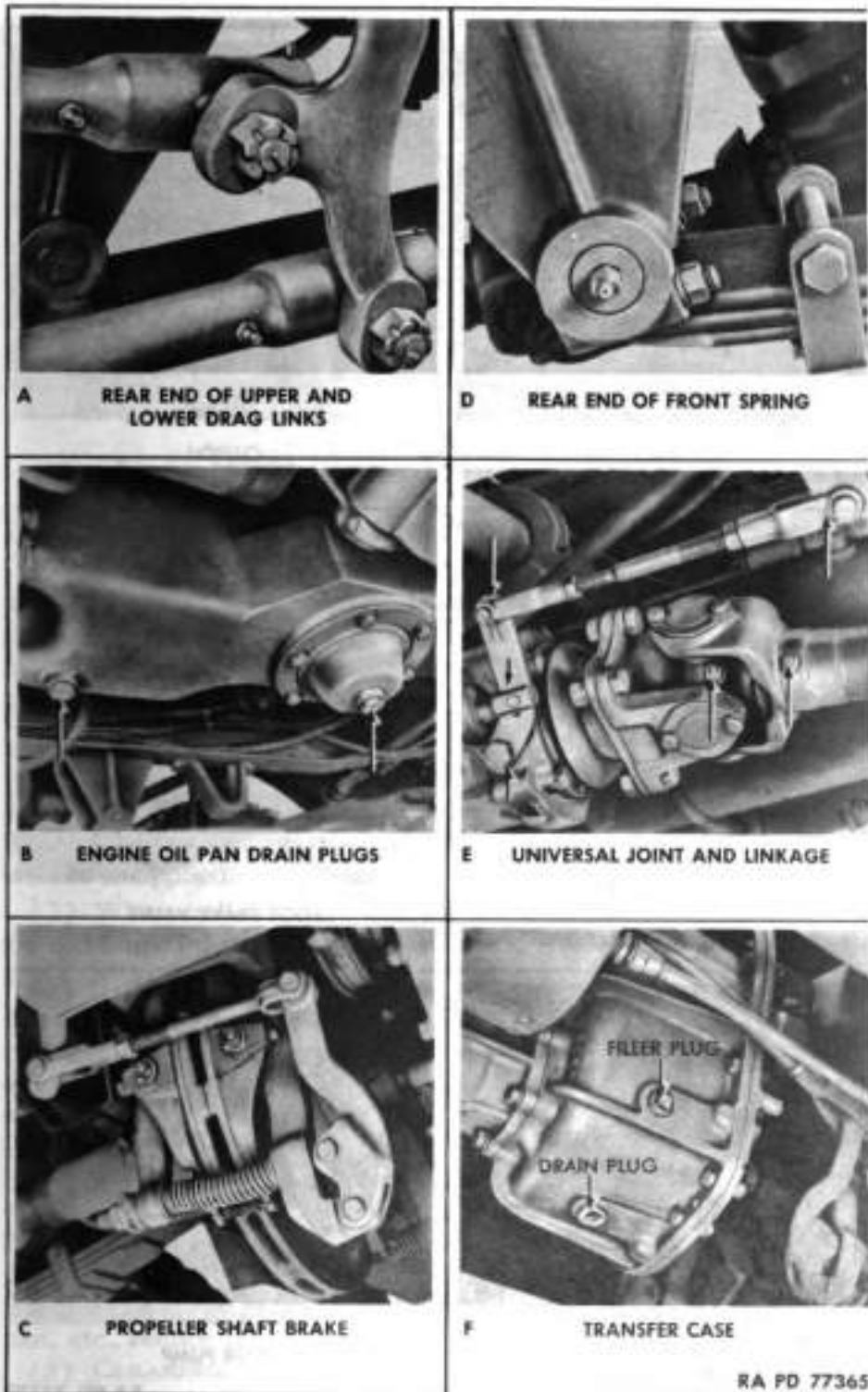

Figure 8 — Lubrication Points — B

4- TO 5-TON 4x4 TRACTOR TRUCK (FEDERAL)

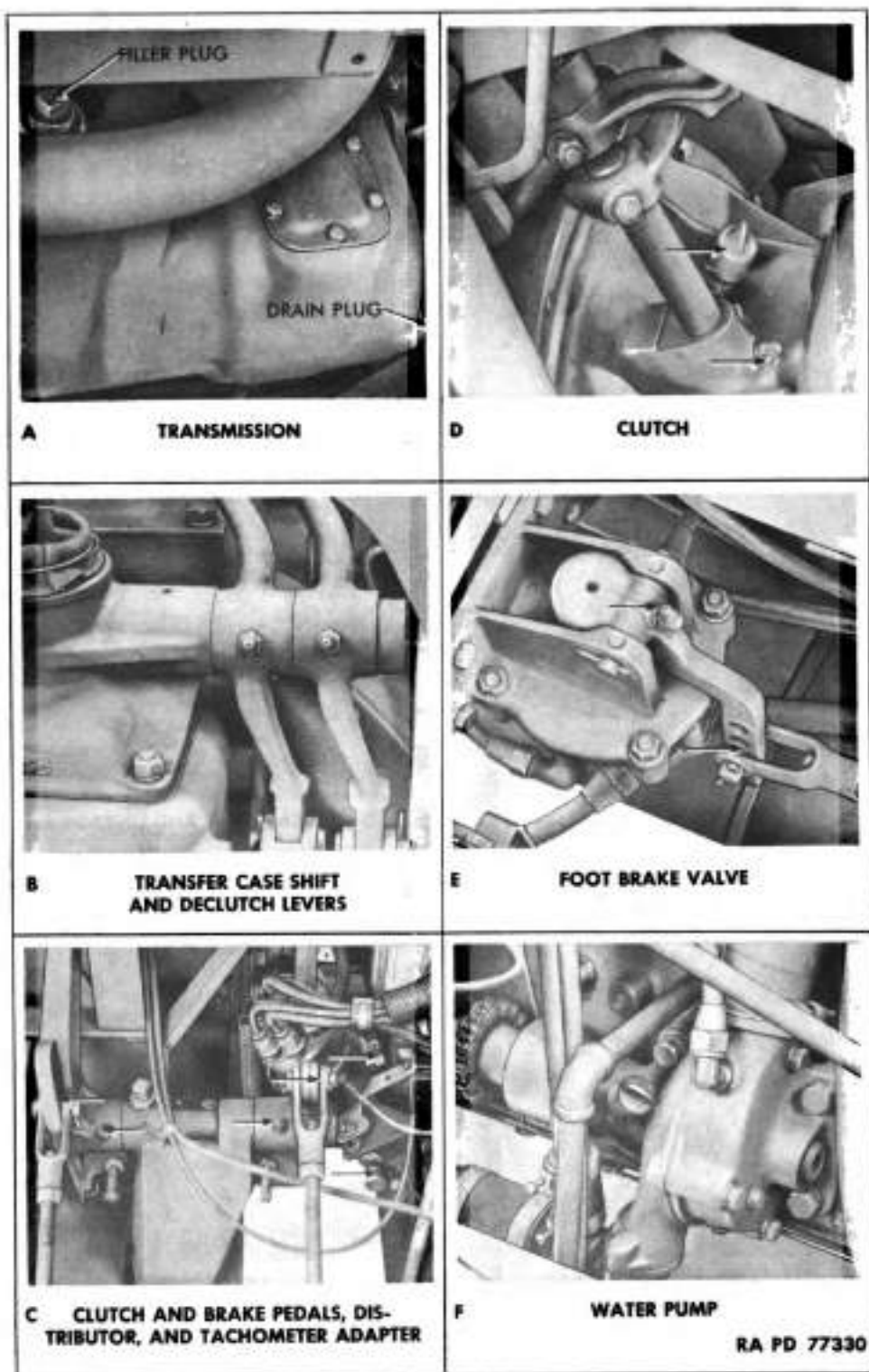

Figure 9 - Lubrication Points - C

## LUBRICATION

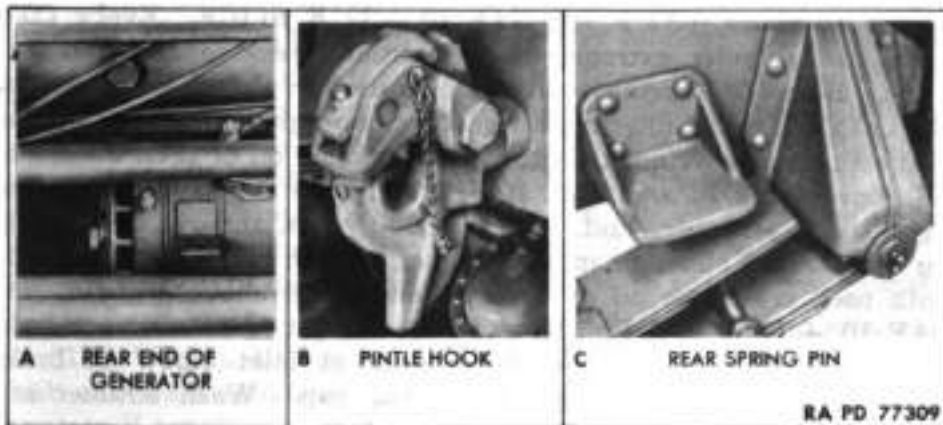

Figure 10 - Lubrication Points - D

## 17. DETAILED LUBRICATION INSTRUCTIONS.

**a. Lubrication Equipment.** Each piece of materiel is supplied with lubrication equipment adequate to maintain the materiel. Be sure to clean this equipment both before and after use. Operate lubricating guns carefully and in such manner as to insure a proper distribution of the lubricant.

**b. Points of Application.**

(1) Red circles surrounding lubrication fittings, grease cups, oilers and oilholes make them readily identifiable on the vehicle. Wipe clean such lubricators and the surrounding surface before lubricant is applied.

(2) Where relief valves are provided, apply new lubricant until the old lubricant is forced from the vent. Exceptions are specified in notes on the Lubrication Guide.

**c. Lubrication Notes on Individual Units and Parts.** The following instructions supplement those notes on the Lubrication Guide which pertain to lubrication and service of individual units and parts. All note references in the guide itself are to the subparagraph below having the corresponding number.

(1) **FITTINGS.** Clean before applying lubricant. Lubricate until new lubricant is forced from the bearing, unless otherwise specified. **CAUTION:** Lubricate chassis points after washing truck and trailer.

(2) **INTERVALS.** Intervals indicated are for normal service. For extreme conditions of speed, heat, water, sand, mud, snow, rough roads, dust, etc., reduce interval by  $\frac{1}{3}$  or  $\frac{1}{2}$ , or more if conditions warrant.

(3) **CLEANING.** Dry-cleaning solvent or Diesel fuel oil will be used to clean or wash all parts. Use of gasoline for this purpose is prohibited. All parts will be thoroughly dry before relubrication.

(4) **AIR CLEANERS.** Daily check level and refill oil reservoir of



## 4. TO 5-TON 4x4 TRACTOR TRUCK (FEDERAL)

engine air cleaner to bead level with used crankcase oil or SAE 30 engine oil above  $+32^{\circ}\text{F}$ . and SAE 10  $+32^{\circ}\text{F}$ . to  $0^{\circ}\text{F}$ . Every 1,000 miles, daily under extreme dust conditions, remove and wash all parts. Below  $0^{\circ}\text{F}$ ., remove oil and operate dry. Wash crankcase oil filler cap and outlet filter breather located on right rear side of engine, and saturate filter element with used crankcase oil or SAE 30 engine oil above  $+32^{\circ}\text{F}$ . and SAE 10  $-32^{\circ}\text{F}$ . to  $0^{\circ}\text{F}$ . Below  $0^{\circ}\text{F}$ ., use light shock absorber fluid. Every 1,000 miles, remove compressor air cleaner and clean air intake strainer. Wash curled hair and recoil with used crankcase oil or SAE 30 engine oil above  $+32^{\circ}\text{F}$ . and SAE 10  $+32^{\circ}\text{F}$ . to  $0^{\circ}\text{F}$ . Below  $0^{\circ}\text{F}$ ., use light shock absorber fluid. Every 6,000 miles, remove air strainer at inlet elbow of brake governor by first removing the strainer cap. Wash strainer and reinstall.

(5) **CRANKCASE.** Drain only when engine is hot (B, fig. 8). Refill to "FULL" mark on gage. Gage reached through inspection cover under driver's seat. Run engine a few minutes and recheck oil level. **CAUTION:** *Be sure pressure gage indicates oil is circulating.*

(6) **OIL FILTERS.** Every 1,000 miles, remove drain plug in filter base (reached by removing cab skirt panel on left side) to drain sediment. Every 6,000 miles or more often if filter becomes clogged, renew filter element. After renewing element refill crankcase to "FULL" mark on gage. Run engine a few minutes, check crankcase level, and add engine oil to "FULL" mark on gage (SAE 30 above  $+32^{\circ}\text{F}$ ., SAE 10  $+32^{\circ}\text{F}$ . to  $0^{\circ}\text{F}$ .; below  $0^{\circ}\text{F}$ ., refer to OFSB 6-11).

(7) **GEAR CASES** (F, fig. 8; A, fig. 7; A, fig. 9). Weekly, check level with truck on level ground and, if necessary, add lubricant to within  $\frac{1}{2}$  inch of plug level when cold or to plug level when hot. Drain and refill at intervals indicated on guide. Drain only after operation. Keep all gear case vents clean (*double reduction front axle and transfer case*). Before refilling, pour  $\frac{1}{2}$  quart of universal gear lubricant through fill plug openings in differential drive pinion cage and transfer case declutching unit housing.

(8) **SHOCK ABSORBERS.** Refill Houde absorbers with heavy shock absorber fluid. Refill Delco absorbers with light shock absorber fluid.

(9) **UNIVERSAL JOINT (FRONT WHEELS)** (C, fig. 7). With truck on level ground, remove inspection plug in lower side of universal joint housing and fill through fitting in wheel hub to level of plug hole.

(10) **CRANKING MOTOR.** Every 6,000 miles, remove starter, clean and lubricate Bendix drive with 6 to 8 drops of special preservative lubricating oil.

(11) **DISTRIBUTOR** (C, fig. 9). Every 6,000 miles, wipe distributor breaker cam lightly with No. 1 general purpose grease above  $+32^{\circ}\text{F}$ . and No. 0 below  $+32^{\circ}\text{F}$ . and lubricate breaker arm pivot and wick

## LUBRICATION

under rotor with one to two drops of SAE 30 engine oil above +32°F.; SAE 10 +32°F. to 0°F.; light preservative lubricating oil below 0°F.

(12) **TURNTABLE (FIFTH WHEEL).** Some types of early models have two additional fittings. Keep the turntable, coupler pin locking jaws and guides well lubricated with No. 1 general purpose grease above +32°F. and No. 0 below +32°F. If covered with grit or sand, clean and relubricate. Every 1,000 miles, lubricate the kingpin lock with SAE 30 engine oil above +32°F.; SAE 10 +32°F. to 0°F.; light preservative lubricating oil below 0°F. to permit easy operation of the hand lever.

(13) **WHEEL BEARINGS.** Remove bearing cone assemblies from hub and wash spindle and inside of hub. Inspect bearing races and replace if necessary. Wet the spindle and inside of hub and hub cap with No. 2 general purpose grease to a maximum thickness of  $\frac{1}{16}$  inch only to retard rust. Wash bearing cones and grease seals. Inspect and replace if necessary. Lubricate bearings with No. 2 general purpose grease with a packer or by hand, kneading lubricant into all spaces in the bearing. Use extreme care to protect bearings from dirt and immediately reassemble and replace wheel. The lubricant in the bearings is sufficient to provide lubrication until the next service period. Do not fill hub or hub cap. Any excess might result in leakage into the brake drum.

(14) **OILCAN POINTS (C and E, fig. 8; C, fig. 7; C and D, fig. 9; A and B, fig. 10).** Every 1,000 miles, lubricate throttle and spark control rod ends, clevises, hinges, latches, pintle hook, foot brake and clutch control linkage, emergency brake control lever spring and ratchet, air compressor rocker arm shaft with SAE 30 engine oil above +32°F.; SAE 10 +32°F. to 0°F.; light preservative lubricating oil below 0°F.

(15) **RUBBER BUSHINGS.** Every 1,000 miles, apply hydraulic brake fluid to shock absorber links (some models). **CAUTION:** Do not use oil.

(16) **POINTS REQUIRING NO-LUBRICATION SERVICE.** Chassis springs, rear spring wearing plates, air compressor.

(17) **POINTS TO BE SERVICED AND OR LUBRICATED BY ORDNANCE MAINTENANCE PERSONNEL.**

(a) *Brake Governor Upper Valve Stem.* Every 12,000 miles, the cover on the brake governor should be removed and the upper valve stem lubricated with a few drops of special preservative lubricating oil.

(b) *Steering Gear Tube Upper Bearing.* When the steering gear is disassembled, the steering gear tube upper bearing will be cleaned and repacked with ball and roller bearing grease.



## 4. TO 5-TON 4x4 TRACTOR TRUCK (FEDERAL)

## Section VII

## TOOLS AND EQUIPMENT STOWAGE ON THE VEHICLE

## 18. VEHICLE TOOLS, EQUIPMENT, AND SPARE PARTS.

a. All tools are stowed in a tool box (fig. 11) attached to the frame on the right-hand side of the truck just ahead of rear wheels. A 1-quart carbon tetrachloride-plunger type fire extinguisher is stored on a bracket between the two seats. The lists below are for information only and are not a basis for requisition. Tools equipment and spare parts furnished are as follows:

## b. Vehicle Tools.

Name	Federal Stock Number
Hammer, machinists, ballpeen, 16-oz	41-H-523
Handle, wheel bearing nut wrench	
Handle, wheel stud nut wrench	41-H-1517-50
Jack, hydraulic, 8-ton, w. handle	41-J-73-5
Pliers, combination, slip joint, 6-in.	41-P-1650
Screwdriver, common, 6-in.	41-S-1076
Wrench, adjustable, single end, 12-in.	41-W-488
Wrench, engineers, open-end, $\frac{3}{8}$ - x $\frac{1}{2}$ -in.	41-W-991
Wrench, engineers, open-end, $\frac{9}{16}$ - x $\frac{11}{16}$ -in.	41-W-1005-5
Wrench, engineers, open-end, $\frac{1}{2}$ - x $\frac{11}{16}$ -in.	41-W-1003
Wrench, engineers, open-end, $\frac{5}{8}$ - x $\frac{3}{4}$ -in.	41-W-1008-10
Wrench, engineers, open-end, $\frac{3}{4}$ - x $\frac{7}{8}$ -in.	41-W-1012-5
Wrench, screw, adjustable, auto. type, 15-in.	41-W-450
Wrench, socket, front wheel bearing nut	41-W-1493-25
Wrench, socket, rear wheel bearing nut	41-W-1991-10
Wrench, socket, wheel stud nut	41-W-3838-30
Wrench, spark plug, w. handle	41-W-3335-30

## c. Equipment and Spare Parts.

Bag, tool	41-B-15
Bracket, for fire extinguisher	38-B-385
Crank, engine starting	
Extinguisher, fire, 1 qt capacity	58-E-202
Gage, tire pressure	8-G-615
Gun, lubricating	41-G-1344-35
Gun, lubricating, hydraulic, chassis	41-G-1344-40
Hose, tire inflation (25 ft long)	
Kit, spare parts	
Nozzle, air chuck	
Oiler	13-O-1530
Pump, tire, hand, single cylinder (except air brake trucks)	B-P-5000
Tire chains, front 9.00 x 20 single (1 pair)	
Tire chains, rear, 9.00 x 20 dual (1 pair)	

**TOOLS AND EQUIPMENT STOWAGE ON THE VEHICLE**

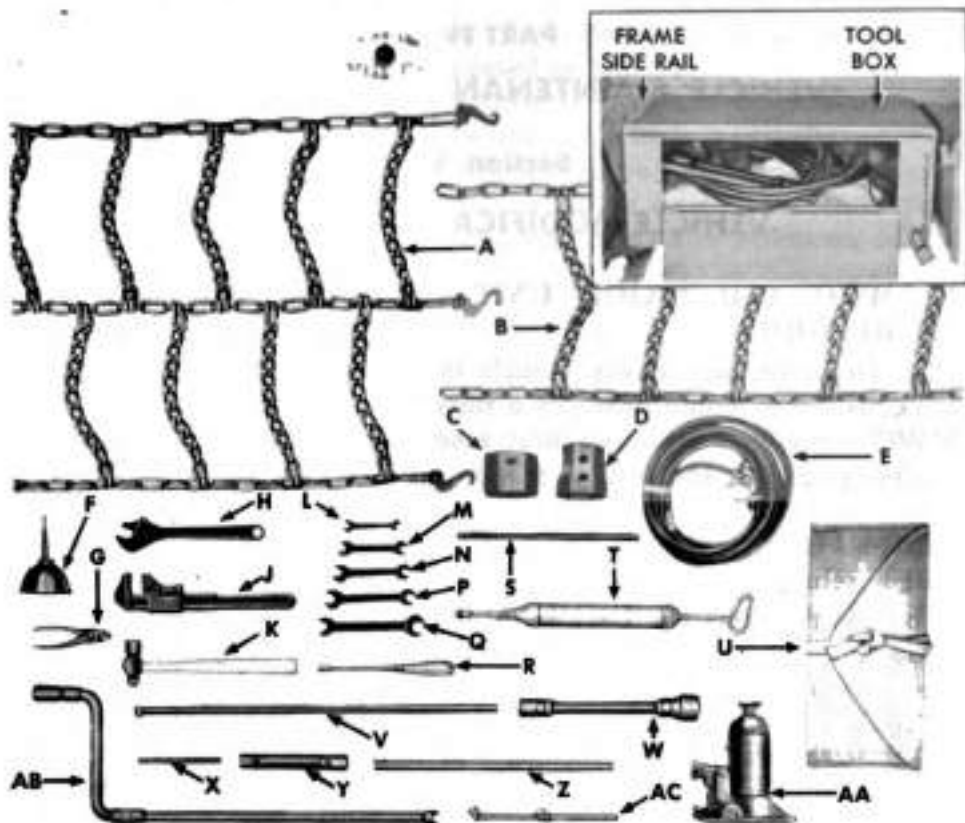

- A—DUAL 9.00 x 20 TIRE CHAIN
- B—SINGLE 9.00 x 20 FRONT TIRE CHAIN
- C—REAR WHEEL BEARING NUT WRENCH
- D—FRONT WHEEL BEARING NUT WRENCH
- E—TIRE INFLATION HOSE
- F—OILER
- G—WIRE-CUTTING, SLIP JOINT COMBINATION PLIERS
- H—CRESCENT WRENCH—8-IN.
- J—AUTOMOBILE-TYPE ADJUSTABLE WRENCH
- K—16-OUNCE MACHINIST BALL PEEN HAMMER
- L—OPEN-END, DOUBLE-HEAD, 15-DEGREE ENGINEER'S WRENCH,  $\frac{3}{8}$ — $\frac{7}{16}$ -IN.
- M—OPEN-END, DOUBLE-HEAD, 15-DEGREE ENGINEER'S WRENCH,  $\frac{1}{2}$ — $\frac{19}{32}$ -IN.
- N—OPEN-END, DOUBLE-HEAD, 15-DEGREE ENGINEER'S WRENCH,  $\frac{9}{16}$ — $\frac{11}{16}$ -IN.
- P—OPEN-END, DOUBLE-HEAD, 15-DEGREE ENGINEER'S WRENCH,  $\frac{3}{8}$ — $\frac{25}{32}$ -IN.
- Q—OPEN-END, DOUBLE-HEAD, 15-DEGREE ENGINEER'S WRENCH,  $\frac{3}{4}$ — $\frac{7}{8}$ -IN.
- R—HEAVY-DUTY SCREWDRIVER WITH INTEGRAL HANDLE
- S—WHEEL BEARING WRENCH HANDLE
- T—HYDRAULIC CHASSIS LUBRICATING GUN
- U—CLOTH TOOL CASE
- V—WHEEL NUT SOCKET WRENCH HANDLE
- W—WHEEL NUT SOCKET WRENCH
- X—SPARK PLUG WRENCH HANDLE
- Y—SPARK PLUG WRENCH
- Z—HYDRAULIC JACK HANDLE
- AA—8-TON HYDRAULIC JACK
- AB—ENGINE STARTING CRANK
- AC—TIRE PRESSURE GAGE

RA PD  
77369

**Figure 11 — Tool Box and Tools**

## 4- TO 5-TON 4x4 TRACTOR TRUCK (FEDERAL)

## PART TWO

## VEHICLE MAINTENANCE INSTRUCTIONS

## Section VIII

## VEHICLE MODIFICATION RECORDS

## 19. MWO AND MAJOR UNIT ASSEMBLY REPLACEMENT RECORD.

a. **Description.** Every vehicle is supplied with a copy of AGO Form No. 478 which provides a means of keeping a record of each MWO completed or major unit assembly replaced. This form includes spaces for the vehicle name and U.S.A. Registration Number, instructions for use, and information pertinent to the work accomplished. It is very important that the form be used as directed and that it remain with vehicle until vehicle is removed from service.

b. **Instructions for Use.** Personnel performing modifications or major unit assembly replacements must record clearly on the form a description of the work completed and must initial the form in the columns provided. When each modification is completed, record the date, hours and or mileage, and MWO number. When major unit assemblies, such as engines, transmissions, transfer cases, are replaced, record the date, hours and or mileage and nomenclature of the unit assembly. Minor repairs and minor parts and accessory replacements need not be recorded.

c. **Early Modifications.** Upon receipt by a third or fourth echelon repair facility of a vehicle for modification or repair, maintenance personnel will record the MWO numbers of modifications applied prior to the date of AGO Form No. 478.

## Section IX

## NEW VEHICLE RUN-IN TEST

## 20. INTRODUCTION.

a. **Purpose.** When a new or reconditioned vehicle is received at the using organization, it is necessary for second echelon personnel to determine whether or not the vehicle will operate satisfactorily when placed in service. For this purpose, inspect all accessories, sub-assemblies, assemblies, tools, and equipment to see that they are in place and correctly adjusted. In addition, they will perform a run-in test of at least 50 miles as directed in AR 850-15, paragraph 25, table III, according to procedures in paragraph 21 below.

## NEW VEHICLE RUN-IN TEST

b. **Correction of Deficiencies.** Deficiencies disclosed during the course of the run-in test will be treated as follows:

- (1) Correct any deficiencies within the scope of the maintenance echelon of the using organization before the vehicle is placed in service.
- (2) Refer deficiencies beyond the scope of the maintenance echelon of the using organization to a higher echelon for correction.
- (3) Bring deficiencies of serious nature to the attention of the supplying organization.

### 21. RUN-IN TEST PROCEDURES.

#### a. Preliminary Service.

(1) **FIRE EXTINGUISHER.** See that portable extinguisher is present, in good condition. Test for proper operation, and mount it securely.

(2) **FUEL, OIL, AND WATER.** Fill fuel tank. Check crankcase oil and coolant supply and add as necessary to bring to correct levels. Allow room for expansion in fuel tank and radiator. During freezing weather, test value of antifreeze and add as necessary to protect cooling system against freezing. **CAUTION:** *If there is a tag attached to filler cap or steering wheel concerning engine oil in crankcase, follow instructions on tag before driving the vehicle.*

(3) **FUEL FILTERS.** Inspect fuel filter for leaks, damage, and secure mountings and connections. Remove drain plug and drain, if any appreciable amount of water or dirt is present, remove elements and clean cases and elements in dry-cleaning solvent. Replace elements using new gaskets.

(4) **BATTERIES.** Make hydrometer and voltage test of batteries and add clean water if needed to level electrolyte to  $\frac{1}{8}$  inch above top of plates.

181.  
1025 (5) **AIR-BRAKE TANKS.** Drain air-brake reservoir tanks. Close valves securely.

(6) **AIR CLEANER AND BREATHER CAP.** Examine carburetor, air compressor, air cleaners, and crankcase ventilator breather cap to see if they are in good condition and secure. Remove element from these units and wash thoroughly in dry-cleaning solvent. Apply a film of oil to breather elements, and fill air cleaner reservoir to head level with fresh oil. Reinstall securely, making sure all gaskets are in good condition and ducts and air horn connections are tight.

(7) **ACCESSORIES AND BELTS.** See that accessories such as carburetor, generator, regulator, cranking motor, distributor, water pump, fan, oil filter, and air compressor are securely mounted. Check the fan, generator and air compressor belts for good condition and adjustment. Belts must have  $\frac{1}{2}$ - to  $\frac{3}{4}$ -inch finger pressure deflection.

(8) **ELECTRICAL WIRING.** Examine all accessible wiring and conduits to see if they are in good condition and securely connected.

(9) **TIRES.** See that all tires, including spare, are properly inflated to 65 pounds cool; that stems are in correct position, all valve caps

**4- TO 5-TON 4x4 TRACTOR TRUCK (FEDERAL)**

present and fingertight. Remove objects lodged in treads and carcasses, and between duals and inspect for damage.

(10) **WHEEL AND FLANGE NUTS.** See that all wheel mounting and axle flange nuts are present and secure.

(11) **FENDERS AND BUMPER.** Examine fenders and bumper for looseness and damage.

(12) **TOWING CONNECTIONS.** Inspect towing hooks, truck tractor fifth wheel and pintle hook for looseness or damage.

(13) **BODY (CAB).** See that all cab and body mountings are secure. Inspect attachments, hardware, glass, doors and windows, to see that they are in good condition, secure and operate properly. See that fifth wheel is properly assembled, in good condition and securely mounted. Be sure trailer connecting mechanism operates properly and latches securely. See that trailer brake lines and connections are in good condition and securely connected or supported. Test all hinges, locks, windshield and window lift mechanism, to see that they function satisfactorily.

(14) **LUBRICATE.** Perform a complete lubrication of the vehicle, covering all intervals, according to the instructions on the lubrication guide, paragraph 17, except gear cases, wheel bearings, and other units lubricated in items (1) to (14). Check all gear case oil levels, and add as necessary to bring to correct level; change only if condition of oil indicates the necessity, or if gear oil is not of proper grade for existing atmospheric temperature. **NOTE:** Perform items (15) through (18) during lubrication.

(15) **SPRINGS AND SUSPENSIONS.** Inspect springs for sag, broken or shifted leaves and loose clips. Check shock absorbers for secure mounting and linkage.

(16) **STEERING LINKAGE.** See that all steering arms, rods, and connections are in good condition and secure; and that gear case is securely mounted and not leaking excessively.

(17) **PROPELLER SHAFTS AND UNIVERSAL JOINTS.** Inspect all propeller shafts and universal joints to see if they are in good condition, correctly assembled, aligned, secure, and not leaking excessively.

(18) **AXLE AND TRANSFER VENTS.** See that axle housing and transfer case vents are present, in good condition, and not clogged.

(19) **CHOKE.** Examine choke to be sure it opens and closes fully in response to operation of choke button.

(20) **ENGINE WARM-UP.** Start engine, noting if cranking motor action is satisfactory, and any tendency toward hard starting. Set hand throttle to run engine at fast idle during warm-up. During warm-up, reset choke button so engine will run smoothly, and to prevent overchoking and oil dilution.

(21) **INSTRUMENTS.**

(a) **Oil Gage.** Immediately after engine starts, observe if oil pressure is satisfactory. (Normal operating pressure, hot, is about

**NEW VEHICLE RUN-IN TEST**

40 pounds at 1,600 revolutions per minute.) Stop engine if pressure is not indicated in 30 seconds.

(b) *Ammeters.* Main ammeter should show slight positive charge for a short period after starting engine, until generator restores to battery, current used in starting. "B" ammeter should show charge to indicate "B" battery is receiving current from generator.

(c) *Temperature Gage.* Engine temperature should rise gradually during warm-up to normal operating range, 140 F. to 160 F.

(d) *Fuel Gage.* Fuel gage should register "FULL" if tank has been filled.

(e) *Viscometer.* With engine oil at normal operating temperature, indicator should remain in ideal range. If pointer remains in heavy range inspect oil for dirt or sludge. If pointer goes to thin range it may indicate oil dilution.

(f) *Tachometer.* White pointer should indicate actual engine revolutions per minute at any given time. Red pointer indicates and remains at highest revolutions per minute attained and should not exceed recommended governed engine speed, 2,300 revolutions per minute.

(g) *Air Pressure Gage.* During warm-up period operate engine at fast idle long enough to observe whether or not air-brake pressure builds up a normal rate to specified maximum (105 pounds) and whether governor then cuts off air from compressor. With the engine at normal idling speed, bleed air pressure from system by repeated brake applications and observe if compressor cuts in at 85 pounds. Low pressure indicator (buzzer) should sound at pressures below 60 pounds.

(h) *Speedometer and Odometer.* When vehicle is in motion, speedometer should indicate vehicle speed, and odometer should register accumulating mileage.

(22) **ENGINE CONTROLS.** Observe if engine responds properly to controls and if controls operate without excessive looseness or binding.

(23) **HORN AND WINDSHIELD WIPERS.** See that these items are in good condition and secure. If tactical situation permits, test horn for proper operation and tone. See if wiper arms will operate through their full range and that blade contacts glass evenly and firmly.

(24) **GLASS AND REAR VIEW MIRRORS.** Clean all body glass and mirrors and inspect for looseness and damage. Adjust rear view mirrors for correct vision.

(25) **LAMPS (LIGHTS) AND REFLECTORS.** Clean lenses and inspect all units for looseness and damage. If tactical situation permits, open and close all light switches to see if lamps respond properly.

(26) **LEAKS, GENERAL.** Look under vehicle, and within engine compartment, for indications of fuel, oil, and coolant leaks. Trace any found to source and correct or report them.

(27) **TOOLS AND EQUIPMENT.** Check tools and on vehicle stow-

## 4- TO 5-TON 4x4 TRACTOR TRUCK (FEDERAL)

age lists, paragraph 18, to be sure all items are present, and see that they are serviceable and properly mounted or stowed.

b. **Run-in Test.** Perform the following procedures (1) to (11) inclusive during the road test of the vehicle. On vehicles which have been driven 50 miles or more in the course of delivery from the supplying to the using organization, reduce the length of the road test to the least mileage necessary to make observations listed below. **CAUTION:** *Continuous operation of the vehicle at speed approaching the maximums indicated on the caution plate should be avoided during the test.*

(1) **DASH INSTRUMENTS AND GAGES.** Do not move vehicle until engine temperature reaches 135°F. Maximum safe operating temperature 200 F. Observe readings of oil gage, ammeters, temperature gage, air pressure gage, tachometer, viscometer, and fuel gage to be sure they are indicating the proper function of the units to which they apply. Also see that speedometer registers the vehicle speed and that odometer registers accumulating mileage.

(2) **BRAKES: FOOT AND HAND.** Test service brakes to see if they stop vehicle effectively without side pull, chatter, or squealing. Parking brakes should hold vehicle on a reasonable incline with  $1\frac{1}{2}$  ratchet travel in reserve. Apply hand application valve to see if it functions without binding.

(3) **CLUTCH.** Observe if clutch operates smoothly without grab, chatter or squeal on engagement, or slippage when fully engaged, under load. See that pedal has  $1\frac{1}{2}$  inch free travel before meeting resistance. **CAUTION:** *Do not ride clutch pedal at any time, and do not engage and disengage now clutch severely or unnecessarily until driven and driving disks have become properly worn in. Never allow pedal free play to become less than  $\frac{3}{4}$  inch. Adjust only according to instructions in paragraph 59.*

(4) **TRANSMISSION AND TRANSFER.** Gearshift mechanism should operate easily and smoothly, and gears should operate without unusual noise and not slip out of mesh. Test front axle declutching for proper operation.

(5) **STEERING.** Observe steering action for binding or looseness, and note any excessive pull to one side, wander, shimmy, or wheel tramp. See that column bracket and wheel are secure. Pay particular attention to Pitman arm to see that it is secure.

(6) **ENGINE.** Be on the alert for any abnormal engine operating characteristics or unusual noise, such as lack of pulling power or acceleration; backfiring, misfiring, stalling, overheating, or excessive exhaust smoke. Observe if engine responds properly to all controls. Do not run engine above governed speed of 2,300 revolutions per minute.

(7) **UNUSUAL NOISE.** Be on the alert throughout road test for any unusual noise from body and attachments, running gear, suspensions

## SECOND ECHELON PREVENTIVE MAINTENANCE

or wheels, that might indicate looseness, damage, wear, inadequate lubrication or underinflated tires.

(8) **HALT VEHICLE AT 10-MILE INTERVALS FOR SERVICES (9) TO (11) BELOW.**

(9) **AIR-BRAKE SYSTEM LEAKS.** With the air pressure at governed maximum and the brakes applied, stop engine. There should not be a noticeable drop in pressure within 1 minute.

(10) **TEMPERATURES.** Cautiously hand-feel each brake drum and wheel hub for abnormal temperatures. Examine transmission, transfer case, and differential housings for indications of overheating and excessive lubricant leaks at seals, gaskets, or vents. *NOTE: Transfer case temperatures are normally higher than other gear cases.*

(11) **LEAKS.** With engine running, and fuel, engine oil, and cooling systems under pressure, look within engine compartment and under vehicle for indications of leaks.

### c. Vehicle Publications and Reports.

(1) **PUBLICATIONS.** See that vehicle Technical Manuals, Lubrication Guide, Standard Form No. 26 (Drivers Report-accident, Motor Transportation) W.D., AGO Form No. 478 (MWO and Major Unit Assembly Replacement Record), are in the vehicle, legible, and properly stowed. *NOTE: U.S.A. registration number and vehicle nomenclature must be filled in on Form No. 478, for new vehicles.*

(2) **REPORTS.** Upon completion of the run-in test, correct or report any deficiencies noted. Report general conditions of the vehicle to designated individual in authority.

---

## SECTION X

### SECOND ECHELON PREVENTIVE MAINTENANCE

#### 22. SECOND ECHELON PREVENTIVE MAINTENANCE SERVICES.

a. Regular scheduled maintenance inspections and services are a preventive maintenance function of the using arms, and are the responsibility of commanders of operating organizations.

(1) **FREQUENCY.** The frequency of the preventive maintenance services outlined herein is considered a minimum requirement for normal operation of vehicles. Under unusual operating conditions, such as extreme temperatures, dusty or sandy terrain, it may be necessary to perform certain maintenance services more frequently.

(2) **FIRST ECHELON PARTICIPATION.** The drivers should accompany their vehicles and assist the mechanics while periodic second echelon preventive maintenance services are performed. Ordinarily the driver should present the vehicle for a scheduled preventive



**4- TO 5-TON 4x4 TRACTOR TRUCK (FEDERAL)**

maintenance service in a reasonably clean condition; that is, it should be dry and not caked with mud or grease to such an extent that inspection and servicing will be seriously hampered. However, the vehicle should not be washed or wiped thoroughly clean, since certain types of defects, such as cracks, leaks, and loose or shifted parts or assemblies are more evident if the surfaces are slightly soiled or dusty.

(3) If instructions other than those contained in the general procedures in step (4) or the specific procedures in step (5) which follow, are required for the correct performance of a preventive maintenance service, or for correction of a deficiency, other sections of this manual pertaining to the item involved, or a designated individual in authority, should be consulted.

(4) **GENERAL PROCEDURES.** These general procedures are basic instructions which are to be followed when performing the services on the items listed in the specific procedures. **NOTE:** *The second echelon personnel must be thoroughly trained in these procedures so that they will apply them automatically.*

(a) When new or overhauled subassemblies are installed to correct deficiencies, care should be taken to see that they are clean, correctly installed, properly lubricated, and adjusted.

(b) When installing new lubricant retainer seals, a coating of the lubricant should be wiped over the sealing surface of the lip of the seal. When the new seal is a leather seal, it should be soaked in SAE 10 engine oil (warm if practicable) for at least 30 minutes. Then the leather lip should be worked carefully by hand before installing the seal. The lip must not be scratched or marred.

(c) The general inspection of each item applies also to any supporting member or connection, and usually includes a check to see whether or not the item is in good condition, correctly assembled, secure, or excessively worn. The mechanic must be thoroughly trained in the following explanations of these terms:

1. The inspection for "good condition" is usually an external visual inspection to determine if the unit is damaged beyond safe or serviceable limits. The term good condition is explained further by the following terms: not bent or twisted, not chafed or burned, not broken or cracked, not bare or frayed, not dented or collapsed, not torn or cut.

2. The inspection of a unit to see that it is "correctly assembled" is usually an external visual inspection to see whether or not it is in its normal assembled position in the vehicle.

3. The inspection of a unit to determine if it is "secure" is usually an external visual examination, a wrench, hand-feel or a pry-bar check for looseness. Such an inspection should include any brackets, lock washers, lock nuts, locking wires, or cotter pins used in assembly.

4. "Excessively worn" will be understood to mean worn close to, or beyond, serviceable limits, and likely to result in a failure if not replaced before the next scheduled inspection.

## SECOND ECHELON PREVENTIVE MAINTENANCE

(d) *Special Services.* These are indicated by repeating the item numbers in the columns which show the interval at which the services are to be performed, and show that the parts, or assemblies, are to receive certain mandatory services. For example, an item number in one or both columns opposite a **TIGHTEN** procedure, means that the actual tightening of the object must be performed. The special services include:

1. *Adjust.* Make all necessary adjustments in accordance with the pertinent section of this manual, special bulletins, or other current directives.

2. *Clean.* Clean units of the vehicle with dry-cleaning solvent to remove excess lubricant, dirt, and other foreign material. After the parts are cleaned, rinse them in clean fluid and dry them thoroughly. Take care to keep the parts clean until reassembled, and be certain to keep cleaning fluid away from rubber or other material that it would damage. Clean the protective grease coating from new parts since this material is usually not a good lubricant.

3. *Special lubrication.* This applies either to lubrication operations that do not appear on the vehicle lubrication chart, or to items that do appear on such charts, but should be performed in connection with the maintenance operations, if parts have been disassembled for inspection or service.

4. *Service.* This usually consists of performing special operations, such as replenishing battery water, draining and refilling units with oil, and changing or cleaning the oil filter or cartridge.

5. *Tighten.* All tightening operations should be performed with sufficient wrench torque (force on the wrench handle) to tighten the unit according to good mechanical practice. Use torque-indicating wrench where specified. Do not overtighten, as this may strip threads or cause distortion. Tightening will always be understood to include the correct installation of lock washers, lock nuts, and cotter pins provided to secure the tightening.

(e) When conditions make it difficult to perform the complete preventive maintenance procedures at one time, they can sometimes be handled in sections, planning to complete all operations within the week if possible. All available time at halts, and in bivouac areas, must be utilized if necessary to assure that maintenance operations are completed. When limited by the tactical situation, items with Special Services in the columns, should be given first consideration.

(f) The numbers of the preventive maintenance procedures that follow are identical with those outlined on W.D. AGO Form No. 461, which is the Preventive Maintenance Service Work Sheet for Wheeled and Half-track Vehicles. Certain items on the work sheet, that do not apply to this vehicle, are not included in the procedures in this manual. In general, the numerical sequence of items on the work sheet is followed in the manual procedures, but in some instances

## 4- TO 5-TON 4x4 TRACTOR TRUCK (FEDERAL)

there is deviation for conservation of the mechanic's time and effort.

(5) **SPECIFIC PROCEDURES.** The procedures for performing each item in the 1,000-mile (monthly) and 6,000-mile (6-month) maintenance procedures are described in the following chart. Each page of the chart has two columns at its left edge corresponding to the 6,000-mile and the 1,000-mile maintenance respectively. Very often it will be found that a particular procedure does not apply to both scheduled maintenance. In order to determine which procedure to follow, look down the column corresponding to the maintenance due, and wherever an item number appears perform the operations indicated opposite the number.

6,000 Mile Maint (6-month)	1,000 Mile Maint (Monthly)	
		<b>ROAD TEST</b>
		<i>NOTE: When the tactical situation does not permit a full road test, perform those items which require little, or no, movement of the vehicle. When a road test is possible, it should be for preferably 5 miles and not over 10 miles.</i>
1	1	<b>Before-operation Service.</b> Perform the before-operation service as described in paragraph 12.
2	2	<b>Air Pressure (Build-up, Governor Cut-off, Low-pressure Indicator).</b> During warm-up period operate engine at fast idle long enough to observe if air-brake pressure builds up at normal rate to specified maximum (105 lb) and that governor then cuts off air from compressor. With engine at normal idling speed, bleed air pressure from system by repeated brake application and observe if compressor cuts in at about 85 pounds. Low-pressure indicator (buzzer) should sound at pressures below 60 pounds. Any abnormal drop in air pressure except from brake application should be investigated by making elimination soapuds tests as described in paragraph 124.
3	3	<b>Dash Instruments and Gages.</b> <b>Oil Pressure Gage.</b> Oil pressure should be 40 pounds minimum at 1,600 revolutions per minute, 10 to 15 pounds at normal idling speed. <b>CAUTION: Stop engine if oil pressure is too low for safe engine operation at any speed.</b> <b>Ammeters.</b> Main ammeter should show a positive (+) charge for short period after starting engine, until generator restores to batteries current used in starting.

## SECOND ECHELON PREVENTIVE MAINTENANCE

6,000 Mile Maint (six- month)	1,000 Mile Maint (mon- thly)	
		<p>Time will depend on condition of charge of batteries and electrical load carried. With batteries fully charged and regulator unit cut in, ammeter may show zero or only slight charge. "B" ammeter should show charge to indicate "B" battery is receiving current from generator. Stop engine and investigate discharge (-) readings with engine running and lights and accessories turned off.</p> <p><i>Viscometer.</i> With engine oil at normal operating temperature, indicator should remain in "ideal" range. If pointer remains in "heavy" range inspect oil for dirt or sludge. If pointer goes to "thin" range it may indicate oil dilution.</p> <p><i>Engine Temperature Gage.</i> Reading should increase gradually during warm-up to normal operating temperature 153°F. to 183°F. <b>CAUTION:</b> <i>Do not move vehicle until engine temperature has reached 135°F. Maximum safe temperature 200°F.</i></p> <p><i>Tachometer.</i> White pointer should indicate actual engine revolutions per minute at any given time. Red pointer indicates and remains at highest revolution per minute attained and should not exceed recommended governed engine speed, 2,300 revolutions per minute.</p> <p><i>Speedometer.</i> While vehicle is in motion, speedometer should register actual vehicle miles per hour, and odometer should record total accumulated mileage.</p> <p><i>Fuel Gage.</i> Should register approximate amount of fuel in tank at all times.</p> <p><i>Air Pressure Gage.</i> Refer to item 2 for specifications and tests.</p>
4	4	<p><i>Horns, Mirrors, and Windshield Wipers.</i> If tactical situation permits, test horns for proper operation and tone. Examine rear vision mirror and wipers to see if they are in good condition, and secure. Test operation of wiper motors and see that wiper blades contact glass evenly and operate through their full range without indications of loose wiper motor mountings. Adjust rear vision mirror for correct vision.</p>
5	5	<p><i>Brakes (Service and Parking, Braking Effect, Foot, Side Pull, Noise, Chatter, Pedal Travel, Hand Control).</i> Operate brakes at various speeds during road test.</p>

## 4- TO 5-TON 4x4 TRACTOR TRUCK (FEDERAL)

6,000 Mile Maint. (1.5- month)	1,000 Mile Maint. (1 mon- th)	
		<p><i>Service Brakes.</i> Apply foot pedal sufficiently to stop vehicle in minimum distance and observe their effectiveness, any pull to one side, unusual noise, or chatter. Pedal should depress with little effort, and should return to "OFF" position when released. Apply hand application valve to see if it functions without binding.</p> <p><i>Parking Brake.</i> Stop vehicle on reasonable incline; apply parking brake and observe if it holds vehicle effectively; that lever has at least <math>\frac{1}{2}</math> travel in reserve, and that ratchet and pawl latch the applied brake securely.</p>
6	6	<p><i>Clutch (Free Travel, Drag, Noise, Chatter, Grab, Slip).</i> Pedal free travel should be <math>1\frac{1}{2}</math> inches before meeting resistance. Test clutch for drag when shifting into low gear. Note any unusual noise when pedal is depressed which may indicate defective or dry release bearing. With transmission in gear, note any tendency to chatter or grab when clutch is engaged or slippage when fully engaged under load.</p> <p><b>NOTE:</b> Never allow pedal free play to become less than <math>\frac{3}{4}</math> inch.</p>
7	7	<p><i>Transmission and Transfer (Lever Action, Declutching, Vibration, Noise).</i> Levers should move into each gear range position easily and quietly. Test declutching lever to see that front axle engages properly. Note any vibration that may indicate loose mountings or noise that may indicate damaged, excessively worn or inadequately lubricated parts.</p>
8	8	<p><i>Steering (Free Play, Bind, Wander, Shimmy, Side Pull, Column, and Wheel).</i> With vehicle in motion move steering wheel fully in both directions and observe whether there is any indication of looseness or binding. Note any tendency to wander, shimmy, or pull to one side. See that steering column and wheel are in good condition and secure.</p>
9	9	<p><i>Engine (Idle, Acceleration, Power, Noise and Governed Speed).</i> Observe engine operating characteristics as follows:</p> <p><i>Idle.</i> Engine should idle smoothly without stalling.</p> <p><i>Unusual Noises.</i> Listen for knocks and rattles as the</p>

## SECOND ECHELON PREVENTIVE MAINTENANCE

6,000 Mile Maint. (Semi- annual)	2,000 Mile Maint. (Monthly)	
		<p>engine is accelerated and decelerated, and while it is under both light and heavy loads.</p> <p><i>Acceleration and Power.</i> Operate the engine at various speeds in all gear ratios, noting if the vehicle has normal pulling power and acceleration. Note any tendency to stall while shifting. A slight ping during fast acceleration is normal. Continued or heavy ping may indicate early timing, or heavy accumulation of carbon.</p> <p><i>Governed Speed.</i> With the vehicle in a low gear, slowly depress the accelerator to the toeboard and by observing the speedometer reading, see if the vehicle reaches, but does not exceed, the governed speed specified on the caution plate. Observe tachometer reading and note if the engine speed exceeds the specified 2,300 revolutions per minute.</p>
10	10	<p><i>Unusual Noises (Attachments, Cab, Wheels).</i> Be on alert during road test for any noise that may indicate loose or damaged attachments mounted on vehicle, loose cab mountings, floor plates, doors, windshield or hardware. Listen particularly for indications of loose wheel mountings.</p>
12	12	<p><i>Air-brake System Leaks.</i> With the air pressure at the governed maximum and the brakes applied, stop the engine. There should not be a noticeable drop in pressure within one minute. If any pressure drop occurs during this check, test the air-brake system for leaks by the soapsuds method.</p>
13	13	<p><i>Temperatures (Brake Drums, Hubs, Axles, Transmission, Transfer).</i> Place hand cautiously on all brake drums and wheel hubs to see if they are abnormally hot. Inspect axle housings, transmission and transfer case for indications of overheating.</p>
14	14	<p><i>Leaks (Engine Oil, Water, Fuel).</i> Look in engine compartment, and under vehicle for indications of engine oil, coolant or fuel leaks. Trace any found to their source and correct or report them.</p>
<p><b>MAINTENANCE OPERATIONS</b></p> <p>Raise Vehicle — Block Safely</p>		
16	16	<p><i>Gear Oil Level and Leaks (Axles, Transmission, and Transfer).</i> Remove filler plugs in front and rear axles,</p>

## 4- TO 5-TON 4x4 TRACTOR TRUCK (FEDERAL)

6,000 Mile Maint (12- month)	1,000 Mile Maint (1 month)	
		transmission, and transfer case and check lubricant levels. Proper level is from lower edge of filler hole when hot, to 1/2 inch below when cold. Allow sufficient time for foaming to subside before checking levels. Note condition of lubricant. If an oil change is due in any of these units or condition of lubricant indicates an oil change is necessary, drain and refill units with fresh specified oil. Note any indications of excessive lubricant leaks at oil seals or gaskets.
17	17	<p><i>Unusual Noises (Engine, Belts, Accessories, Transmission, Transfer, Shafts and Joints, Axles and Wheel Bearings).</i> With engine running observe as follows:</p> <p><i>Engine, Belts and Accessories.</i> Accelerate and decelerate the engine momentarily and listen for any unusual noise in these units that might indicate damaged, loose, or excessively worn engine parts, drive belts or accessories. Also be sure to locate and correct or report any unusual engine noise heard during the road test.</p> <p><i>Transmission, Transfer, Propeller Shafts and Joints, Axles, and Wheel Bearings.</i> With the transmission in an intermediate gear, and front driving axle engaged, operate these units at a constant, moderate speed by use of the hand throttle, and listen for any unusual noise that might indicate damaged, loose or excessively worn unit parts. Also observe all propeller shafts and wheels for vibrations and run-out, and for vibration in the other units which may indicate looseness or unbalance. Slow running wheels may indicate tight brakes or wheel bearings. Also be sure to locate, correct, or report any noise noted during road test.</p>
18	18	<p><i>Cylinder Heads and Gaskets.</i> Look for cracks or indications of oil, coolant, or compression leaks around studs, cap screws and gaskets. <b>CAUTION:</b> <i>Cylinder heads should not be tightened unless there is definite evidence of leaks. If tightening is necessary, use torque-indicating wrench, and tighten head nuts in the proper sequence and to 52 1/2 foot-pounds tension. Be sure bond straps are secure.</i></p>
	19	<p><i>Valve Mechanism (Clearance, Cover Gaskets).</i> Adjust valve stem clearance only if noisy. Intake valve clearance must be 0.006 inch, hot; exhaust valve clearance, 0.010 inch, hot.</p>

## SECOND ECHELON PREVENTIVE MAINTENANCE

6,000 Mile Maint (six-month)	1,000 Mile Maint (monthly)	
19		<i>Adjust.</i> Set valve stem clearance to above specifications. See if valve stems, springs, seats and locks, are in good condition, correctly assembled and secure. Inspect valve covers to be sure they are in good condition. Reinstall them securely using new gaskets if necessary.
22	22	<i>Battery (Cables, Hold-down, Carrier, Record Gravity and Voltage).</i> Inspect battery case for cracks and leaks. Clean top of battery. Inspect cables, terminals, bolts, posts, straps and hold-downs for good condition. Test specific gravity and voltage and record on W.D. AGO Form No. 461. Specific gravity readings below 1.225 indicate battery should be recharged or replaced. Electrolyte level should be above top of plates and may extend 1/2 inch above plates.
22		Perform high-rate discharge test according to instructions for "condition" test which accompany test instrument and record voltage on W.D. AGO Form No. 461. Cell variation should not be more than 30 percent. <i>NOTE: Specific gravity must be above 1.225 to make this test.</i>
22	22	Bring electrolyte to proper level by adding distilled or clean water. Clean entire battery and carrier. Repaint carrier if corroded. Clean battery cable terminals, terminal bolts and nuts, and battery posts and grease lightly. Inspect bolts for serviceability. Tighten terminals and hold-downs carefully to avoid damage to battery. Tighten battery to cover bond straps.
	20	<i>Spark Plugs (Gaps, Deposits).</i> Without removal wipe off plugs and examine insulators for damage or indications of compression leaks.
20		Remove all plugs and examine to see if they are in good condition. Pay particular attention to broken insulators, excessive carbon or oxide deposits, and to electrodes burned thin. Clean plugs thoroughly. If plug cleaner is not available, install new or reconditioned plugs. ( <i>NOTE: Do not install plugs until item 21 has been performed.</i> ) Set plug gaps to 0.025 inch by bending only grounded electrodes.
21		<i>Compression Test.</i> Test compression with all spark plugs removed. Compression pressure at cranking speed is normally 90 to 95 pounds. There should be



## 4. TO 5-TON 4x4 TRACTOR TRUCK (FEDERAL)

6,000 Mile Mant (six- month)	1,000 Mile Mant (mon- thly)	
		not more than 10-pound variation between cylinders. Record compression pressures on space provided on back of work sheet, Form No. 461.
23	23	<i>Crankcase (Leaks, Oil Level).</i> With engine idling examine crankcase, valve covers, timing-gear cover, and clutch housing for oil leaks. Stop engine and after oil has drained into crankcase, check to see if it is up to proper level. If an oil change is due, or condition of oil indicates the necessity, drain crankcase and refill to correct level with fresh specified oil. NOTE: Do not again start engine until item 23 has been performed.
24	24	<i>Oil Filters and Lines.</i> Inspect filters and external engine oil lines to see if they are in good condition, secure, and not leaking. Remove filter body drain plugs and drain off contents. Remove filter cartridge and check condition. If cartridge change is due, or condition indicates the necessity, replace with new cartridge being sure gaskets are in place and tighten covers and drain plugs securely.
25	25	<i>Radiator (Core, Shell, Mountings, Hose, Cap and Gasket, Antifreeze Record, Overflow Pipe).</i> Inspect all applicable items to see if they are in good condition, secure, and not leaking. Be sure overflow pipe is not kinked or clogged. Examine condition of coolant to see whether it is so contaminated that cooling system should be cleaned. If cleaning is necessary, proceed only according to current directives covering proper procedure and recommended cleaner, neutralizer, and inhibitor materials. Clean all insects, dirt or grease deposits from core air passages and inspect for bent cooling fins. CAUTION: Use only a suitably shaped piece of wood or blunt instrument to straighten fins. If antifreeze is in use, test its protective value and record in space provided on back of work sheet Form No. 461.
25		<i>Tighten.</i> Carefully tighten all loose radiator mountings, water connections and hose clamps and bond straps.
26	26	<i>Water Pump and Fan.</i> Inspect pump to see if it is in good condition, secure and not leaking. Examine shaft for end play or bearing looseness. Inspect fan to see if it is in good condition and that blades and hub are secure. Loosen drive belts and examine fan for hub or

## SECOND ECHELON PREVENTIVE MAINTENANCE

6,000 Mile Maint (six- month)	1,000 Mile Maint (month- ly)	
		bearing wear. Leave drive belts loose until adjustment is made (item 29).
		<i>Tighten.</i> Carefully tighten water pump and fan assembly and mounting nuts.
27	27	<i>Generator, Starter, and Switch.</i> Inspect generator, cranking motor and cranking motor switch to see if they are in good condition, securely mounted, and if wiring connections are clean and secure. See that generator radio noise capacitor is secure and not damaged.
27		Remove generator and cranking motor inspection covers and examine commutators and brushes to see if they are in good condition and clean; if brushes are free in brush holders and have sufficient spring tension to hold them in proper contact with commutators; and if brush connection wires are secure and not chafing.
27		<i>Clean.</i> Blow out commutator end of generator and cranking motor with compressed air. If commutators are dirty, clean only with 2.0 flintpaper (do not use emery) placed over end of suitable sized piece of wood and again blow out with air.
27		<i>Tighten.</i> Carefully tighten cranking motor mounting bolts securely.
28	28	<i>Air Compressor (Unloader Valve, Governor, Lines).</i> Examine the air compressor to see that it is in good condition, properly aligned with its drive pulleys, and secure. Check unloader valve for satisfactory valve clearance. See if the governor appears to be in good condition and secure; if all the compressor water, oil, and air lines within engine compartment are in good condition and secure, and that oil and water lines do not leak.
		<i>Clean.</i> Clean governor hair air strainer in dry-cleaning solvent; dry, and apply a thin film of engine oil to strainer and reinstall.
28		<i>Special Lubrication.</i> Apply a few drops of engine oil on the unloader valve fulcrum pin. Apply a few drops of kerosene or dry-cleaning solvent on upper valve stem of governor. Adjust unloader valve clearance 0.010 inch to 0.015 inch.

## 4- TO 5-TON 4x4 TRACTOR TRUCK (FEDERAL)

6,000 Mile Maint. (Six- month)	1,000 Mile Maint. (Month- ly)	
29	29	<p><i>Drive Belts and Pulleys.</i> Examine all drive belts for evidence of fraying condition, excessive wear, and deterioration. Inspect all drive pulleys and hubs to see if they are in good condition and securely mounted.</p> <p><i>Adjust.</i> Set adjustment so drive belts have <math>\frac{1}{2}</math>- to <math>\frac{3}{4}</math>-inch finger-pressure deflection.</p>
30	30	<p><i>Tachometer Drive and Adapter.</i> See if they are in good condition, correctly assembled, and secure. Inspect the flexible drive shaft for kinks, and connection for indications of oil leaks.</p>
31	31	<p><i>Distributor (Cap, Rotor, Points, Shaft, Advance Units).</i> Observe if distributor body and external attachment are in good condition and secure. Examine other parts as follows:</p> <p><i>Cap, Rotor, and Points.</i> Clean dirt from cap and remove. Inspect cap, rotor and breaker plate to see if they are in good condition, secure and serviceably clean. Pay particular attention to cracks in cap and rotor, corrosion of terminals and connections, and to burned rotor bar or contact points. See that points are well aligned and adjusted to 0.020 inch when wide open.</p> <p>If inside of distributor is dirty, remove assembly, clean in solvent, dry thoroughly with compressed air and lubricate its friction parts very lightly. When cleaning remove wick and lubrication cup, clean them, recoil and replace after cleaning distributor. If breaker points are pitted, burned or worn to an unserviceable degree, replace. Also replace condenser if points are burned as this may be the cause. When cleaning points use fine file or 2,0 flintpaper (never use emery) and blow out filings with compressed air.</p> <p><i>Shaft.</i> Test shaft by hand feel for excessive wear in shaft or bushings.</p> <p><i>Centrifugal Advance.</i> Install rotor on shaft and test distributor governor by finger force for normal range of movement permitted by mechanism. Note if it will return to original position when released without hang up or binding.</p>
31	31	<p><i>Special Lubrication.</i> Lubricate cam surfaces, breaker arm pin, and wick according to lubrication guide instructions.</p>

## SECOND ECHELON PREVENTIVE MAINTENANCE

6,000 Mile Maint (6-18- month)	1,000 Mile Maint (1-3- month)	
31		<i>Adjust.</i> Set breaker point gaps to 0.020 inch.
32	32	<i>Coil and Wiring.</i> Inspect coil, ignition wiring including shielding or conduits to see if they are in good condition, clean, securely connected and properly supported. Be sure radio noise resistor-suppressors on spark plug and coil to distributor wires and coil filter unit are in good condition and properly connected. Inspect all low voltage wiring in engine compartment in a like manner.
33	33	<i>Manifolds and Gaskets.</i> Inspect for looseness, damage or exhaust leaks at gaskets. Examine for evidence of cracks or sand holes usually indicated by carbon streaks.
33		<i>Tighten.</i> Carefully tighten all manifold assembly and mounting nuts securely.
34	34	<i>Air Cleaner.</i> Inspect carburetor air cleaner to see if it is in good condition, securely mounted and connected and not leaking. Remove reservoir and element, clean in dry-cleaning solvent; dry, fill reservoir to proper level with clean engine oil and reassemble. Be sure gaskets are in place, and that bond straps, and all joints and air horn connections tight.
35	35	<i>Breather Cap.</i> Inspect crankcase breather cap to see if it is in good condition, secure and not leaking. Remove oil reservoir and element, wash clean in dry-cleaning solvent, refill reservoir with fresh engine oil and reassemble securely.
36	36	<i>Carburetor (Choke, Throttle, Linkage and Governor).</i> See if they are in good condition, correctly assembled, and securely installed; that carburetor does not leak; that control linkage, including choke and throttle shaft, is not excessively worn; if choke valve opens fully when the control is in its released position; if throttle valve opens fully when the accelerator is fully depressed; and if the governor is secure and properly sealed.
37	37	<i>Fuel Filter and Lines.</i> Examine filter to see if it is in good condition, securely mounted and connected and not leaking. <i>Clean.</i> Close fuel shut-off and remove filter sediment bowl and element. Wash clean in dry-cleaning solvent and reassemble securely being sure gaskets are in place.

## 4. TO 5-TON 4x4 TRACTOR TRUCK (FEDERAL)

6,000 Mile Mant (six- month)	1,000 Mile Mant (month- ly)	
		(CAUTION: <i>If element cannot be cleaned by washing replace unit. Do not scrape element to clean</i> ). Turn on fuel supply and recheck for leaks.
38	38	<i>Fuel Pump (Pressure)</i> . Inspect pump to see if it is in good condition, securely mounted and not leaking. Remove sediment bowl and screen and wash in dry-cleaning solvent. Be sure gasket is in place and serviceable when bowl is reinstalled.
38		Attach a test gage to pressure side of fuel pump and after starting engine as in item 39 see that pressure is satisfactory. Should be 2 pounds minimum, 3 $\frac{3}{4}$ pounds maximum at idle speed.
39	39	<i>Starter (Action, Noise, Speed)</i> . Start the engine observing if general action of cranking motor is satisfactory, particularly that it engages and operates properly without excessive noise and has adequate cranking speed; and if the engine starts readily. Also, as soon as engine starts, note whether oil pressure gage and ammeter indications are satisfactory.
40	40	<i>Leaks (Engine Oil, Fuel, and Water)</i> . With engine running recheck all points of oil, fuel and cooling systems for leaks. Trace any found to source and correct or report them.
41	41	<i>Ignition Timing (Advance)</i> . With engine running and a neon timing light connected, observe if ignition timing is correct. Also note whether automatic controls advance the timing as engine is accelerated gradually.
41		<i>Adjust</i> . Ignition timing to specifications in paragraph 81 b.
42	42	<i>Engine Idle and Vacuum Test</i> . Inspect as follows: <i>Adjust</i> . Connect a vacuum gage to intake manifold, adjust engine to its normal idle speed by means of throttle stop screw, and then adjust the idle-mixture adjusting needle until vacuum gage indicates a steady maximum reading. If these latter adjustments are made simultaneously, time will be saved.
42	42	<i>Vacuum Test</i> . With the engine running at normal idling speed, vacuum gage should read about 18 to 21 inches and pointer should be steady. A badly fluctuating needle between 10 and 15 inches may indicate a defec-

## SECOND ECHELON PREVENTIVE MAINTENANCE

6,000 Mile Maint (3- month)	1,000 Mile Maint (1- month)	
		<p>tive cylinder head gasket or valve. An extremely low reading may indicate a leak in intake manifold or gasket. Accelerate and decelerate engine quickly. If vacuum gage indicator fails to drop to approximately 2 inches as throttle is opened, and then fails to recoil to at least 24 inches as throttle is closed, it may be an indication of diluted oil, poor piston ring sealing, or abnormal restriction in carburetor, air cleaner, or exhaust. <b>NOTE:</b> <i>Above readings apply to sea level. There will be approximately a 1-inch drop for each 1,000 feet of altitude.</i></p>
43	43	<p><b>Regulator Unit (Connections, Voltage, Current, and Cut-out).</b> Inspect regulator unit and radio suppression filters, to see if they are in good condition, securely mounted and connected and clean.</p> <p><b>Test.</b> Connect a low-voltage-circuit tester and observe if voltage regulator, current regulator, and cut-out, control generator out-put properly. Follow instructions in vehicle manual or those which accompany test instrument. Replace if test shows faulty operation. <b>CAUTION:</b> <i>This test should be made only after regulator unit has reached normal operating temperature.</i></p>
44	44	<p><b>Power Tire Inflation (Connection, Line).</b> Inspect tire inflation connection at reserve tank to see that it is in good condition and clean. Be sure cap is present and connected by safety chain. Note whether valve turns easily and is not excessively worn. Examine air hose for deterioration and check for damage or clogging. Connect hose and test system for proper function when performing item No. 47.</p>
47	47	<p><b>Tires and Rims (Valve Stems and Caps, Condition, Direction, Matching Spare Carrier).</b> Inspect as follows:</p> <p><b>Valve Stems and Caps.</b> Observe if all valve stems are in good condition and in correct position, and if all valve caps are present and installed securely. Do not tighten with pliers.</p> <p><b>Condition.</b> Examine all tires for cuts, bruises, breaks, and blisters. Remove embedded glass, nails, and stones. Look for irregular tread wear, watching for any sign of flat spots, cupping, feather edges, and one-sided wear. Remove tires worn thin at center of tread (or other un-</p>

## 4- TO 5-TON 4x4 TRACTOR TRUCK (FEDERAL)

6,000 Mile Maint (Semi- monthly)	1,000 Mile Maint (Monthly)
--	-------------------------------------

47	
48	

serviceable tires) and exchange for new or retreaded tires. Any mechanical deficiencies causing such conditions should be determined and corrected or reported. Wheel positions of tires with irregular wear should be changed to even up wear. Front tires, worn irregularly, should be moved to rear-wheel positions.

*Direction.* Directional tires and nondirectional tires should not be installed on same vehicle. Directional tires on rear wheels should be mounted so that the "V" of chevron will point down when viewed from the front. Directional tires on all front wheels will ordinarily be mounted so that "V" of chevrons will point up when viewed from front of vehicle.

*Matching.* With tires properly inflated, inspect them to see if they are matched according to over-all circumference and type of tread.

*Spare-tire Carriers.* See whether spare-tire carriers are in good condition and secure.

*Rims.* All rims and their lock rings or flanges should be in good condition and secure.

*Tighten.* Tighten all wheel rim flange or lug nuts securely.

*Service.* With tires properly inflated to 65 pounds (cool) check over-all circumference of all tires including spares. Select tires to be mounted on duals or on driving axles, so they will not have differences in over-all circumference exceeding the 1/4-inch limits specified in current directives and bulletins. Mount all dual tires with the larger tire outside. The valve stem on inner wheels should point out and the valve stem on outer wheel should point in, and should be opposite each other. Spares must be matched properly and mounted for use on one of the road wheels at intervals not exceeding 90 days. A convenient time to do this is during these maintenance services. After performing the tire-matching service, do not reinstall wheels until wheel-bearing services are completed.

*Rear Brakes (Drums, Supports, Cams, and Shafts).* Inspect and service as follows: Remove rear wheels. NOTE: On 6,000-mile maintenance several wheel bear-

SECOND ECHELON PREVENTIVE MAINTENANCE

6,000 Mile Maint (1-2 months)	1,000 Mile Maint (Monthly)
---	-------------------------------------

ing and brake items up to 52 are group services and overlap. Perform in best order for economy of time and orderly reassembly.

**Drums and Supports.** Clean dirt and grease from drums and supports (dust shields) keeping dry-cleaning solvent away from linings. Examine drums and supports to see if they are in good condition, securely mounted, and if drums are excessively worn or scored.

**Cams and Shafts.** See if cams and shafts, where they contact, are excessively worn; if camshafts operate free in collar and if shafts and collars are worn.

**Tighten.** Tighten brake support cap screws and hub to drum nuts securely.

49 **Rear Brake Shoes (Linings, Anchors, Springs).** Examine linings through inspection holes to see if they are so worn, rivet heads may contact drums within next 1,000 miles of operation. If vehicle has been operated in deep water, mud or loose sand, remove right rear wheel and examine lining for damage. If this lining must be replaced, remove all wheels, check their brakes and service as necessary, being sure to clean, lubricate and adjust all removed wheel bearings as described in item 52, below, for 6,000-mile service.

**Adjust.** Adjust shoes by minor method if necessary.

Remove rear wheels and inspect linings to see if they are in good condition, tightly secured to brake shoes, in good wearing contact with drums, free of dirt or lubricant and not excessively worn. Also see if shoes are in good condition, properly secured to anchors, guides and retracting springs and that springs have sufficient tension to return shoes properly to released position. Thickness of lining at most worn points should be enough for at least 1,000 miles of service before rivet heads are likely to contact drums.

**Clean.** Clean all dirt and grease from linings with wire brush, cloth, or compressed air.

**Adjust.** After subsequent related items to 60 inclusive are completed, adjust shoes by minor method. If new linings have been installed, adjust by major method described in paragraph 127 b. Adjust slack adjusters



## 4- TO 5-TON 4x4 TRACTOR TRUCK (FEDERAL)

6,000 Mile Maint (100- 1000H)	1,000 Mile Maint (100- 100L)	
		so diaphragm push-rod travel is at minimum as described in paragraph 127 b.
52	52	<i>Rear Wheels (Bearings, Seals, Drive Flanges and Nuts).</i> Inspect and service as follows:
	52	<i>Wheels.</i> Inspect wheels to see if they are in good condition and secure.
		<i>Bearings and Seals.</i> Check for looseness of wheel bearing adjustment. Revolve wheels and listen for evidence of dry or damaged bearings. Inspect around flanges and brake supports for lubricant leaks.
		<i>Drive Flanges and Nuts.</i> Note if they are in good condition and if nuts are tightened securely.
52		<i>Clean.</i> Disassemble rear wheel bearings and oil seals. Clean thoroughly in dry-cleaning solvent and examine bearing cups and cones to see if they are in good condition. If machined surfaces they contact are in good condition, and if there is any excessive wear.
52		<i>Special Lubrication.</i> When all of the related items are to the point where wheel bearings are to be re-installed lubricate bearings according to lubrication guide, paragraph 17 c (13). Coat the cups or outer races and the lips of the oil seals with lubricants and install new lubricant retainer seals if necessary. <b>CAUTION:</b> Do not pack the large cavity in wheel hubs between wheel bearings with lubricant. To do so will cause leakage past the seals.
52		<i>Adjust.</i> After lubricating wheel bearings, reassemble hub and drum assemblies into place and adjust wheel bearings correctly according to paragraph 135 b. After bearings have been adjusted and adjustment securely locked, bearings should be neither loose nor so tight they bind.
	53	<i>Front Brakes (Drums, Supports, Cam and Shafts, Hose, Air Chambers, Push Rods and Seals, Slack Adjusters).</i> Inspect brake hose, chambers, push rods and seals, and slack adjusters to see if they are in good condition, correctly assembled, and secure.
53		Remove front wheels and inspect and service as follows:

## SECOND ECHELON PREVENTIVE MAINTENANCE

6,000-Mile Maint Intvl (Months)	1,000-Mile Maint Intvl (Miles)	
		<p><i>Drums and Supports.</i> Clean and inspect in same manner as in item 48.</p> <p><i>Cams and Shafts.</i> Inspect in same manner as in item 48.</p>
	54	<p><i>Front Brake Shoes (Linings, Anchors, Springs).</i> Inspect in same manner as in item 49.</p> <p><i>Adjust.</i> Adjust by minor method if necessary</p>
54		<p>Remove front wheels and inspect shoes, linings, anchors and springs in same manner as in item 49 at 6,000-mile service.</p> <p><i>Clean.</i> Clean in same manner as in item 49.</p>
54	54	<p><i>Adjust.</i> Adjust in same manner as in item 49 after subsequent related items to 60 inclusive are completed.</p>
55	55	<p><i>Steering Knuckles (Joints, Bearings, Seals).</i> Inspect to see if knuckle housings are in good condition. Look particularly for cracks around steering arms. See if outside knuckle felt seals and seal flanges are in good condition and secure. Remove lubrication plug and examine sample of lubricant to see if it appears to be contaminated.</p>
55		<p><i>Clean.</i> Remove constant velocity U-joint assembly. Wash thoroughly in dry-cleaning solvent without disassembly of U-joint. Inspect parts to see if they are in good condition and not excessively worn. Pay particular attention to U-joint washers, balls and races, axle splines, flanges and pivot bearings or bushings.</p>
55		<p><i>Special Lubrication.</i> Pack new lubricant well into constant velocity U-joint until it fills all space between balls, cages, and races. Reassemble steering knuckle taking care to replace any unserviceable lubricant retainer seals, boots or gaskets.</p>
55		<p><i>Adjust.</i> Use every precaution to reinstall shims and spacers in the original position from which they were removed at disassembly to insure correct pivot bearing and axle end play adjustment.</p>
56	56	<p><i>Front Springs (Clips, Leaves, U-Bolts, Hangers, and Shackles).</i> See if they are in good condition, correctly assembled, and secure. Spring clips and bolts should be in place; spring leaves should not be slotted out of their</p>

## 4- TO 5-TON 4x4 TRACTOR TRUCK (FEDERAL)

6,000 Mile Maint (5th month)	1,000 Mile Maint (10th month)	
		correct position. This may be an indication of a sheared center bolt. Note if deflection of both springs is normal and approximately the same. Test hangers and bolts for excessive wear by means of a pry bar. <i>Tighten.</i> Tighten all spring U-bolts securely and uniformly.
57	57	<i>Steering (Arms, Tie Rods, Drag-link, Seals, and Boots, Pitman Arm, Gear, Column and Wheel).</i> See if these items are in good condition, correctly and securely assembled and mounted, if steering gear case is leaking lubricant and if lubricant is at proper level. Pay particular attention to Pitman arm to see if it is securely mounted and not bent out of its normal shape. Also observe if steering system is in good adjustment. See that bond strap from column to bracket is secure.
57		<i>Tighten.</i> Tighten Pitman-arm-shaft nut securely. Also tighten steering-gear-case assembly and mounting nuts or screws, taking care not to disturb adjusting screws and lock nuts. <b>CAUTION:</b> Loosen steering column bracket when tightening steering case mounting nuts, so as not to distort column.
58	58	<i>Front Shock Absorbers and Links.</i> See if bodies are in good condition, secure to frame and not leaking, if links are secure and not damaged and if rubber bushings are hard or cracked, apply brake fluid to exposed surfaces.
58		<i>Serve.</i> Fill shock absorber bodies with specified fluid. Work arm several times and add more fluid. Repeat operation until all air is expelled and reservoir is full. Then disconnect link and observe if action is normal. When arm is moved by hand there should be resistance both ways.
60	60	<i>Front Wheels (Bearings, Seals, Flanges, Axle End Play and Nuts).</i> Inspect front wheels, bearings, seals, drive flanges and nuts in same manner as in item 52 for similar rear wheel items.
60		<i>Clean.</i> Disassemble, clean, and inspect the front-wheel bearings and oil seals in the same manner as described in item 52, taking care to check the U-joint end play as the drive flanges are removed so that the end play adjustment may be made conveniently, when reassembling.

## SECOND ECHELON PREVENTIVE MAINTENANCE

6,000 Mile Mint (1.0 mon(h)	1,000 Mile Mint (1.0 mon- thly)	
60		<i>Special Lubrication.</i> Apply in same manner as described in item 52.
60		<i>Adjust.</i> Adjust wheel bearings in same manner as described in item 52, and adjust brake shoes as described in item 49.
61	61	<i>Front Axle (Pinion End Play, Seal, Vent and Alignment).</i> If front axle appears to be out of line, measure distance from front spring eyebolt to center of axle spring pad on each side. Distance should be equal. Inspect axle housing to see if it is in good condition and not leaking. Examine pinion shaft for excessive end play and seal for leaks. <i>Clean.</i> Clean axle housing vent thoroughly.
62	62	<i>Front Propeller Shaft (Joints, Alinement, Seals, and Flanges).</i> See if these items are in good condition, correctly and securely assembled and mounted; if the U-joints are properly alined with each other and are not excessively worn; that the slip joint is free, not excessively worn, and well lubricated; and that the seals on the U-joints and slip joint do not leak.
62		<i>Tighten.</i> Tighten all U-joint assembly and companion flange bolts securely.
63	63	<i>Engine (Mountings, Ground Strap, Side Panel).</i> These items should be in good condition and securely mounted and connected. Be sure to examine both front and rear engine mountings, and to see, on rubber mountings, that rubber is not separating from its metal backing. If mounting bolts are loose, tighten them properly, taking care not to overtighten. Remove oil or grease from rubber mountings. Apply a film of brake fluid if rubber is hard or cracking. See that bond straps at engine supports are secure.
64	64	<i>Hand Brake (Ratchet and Pawl, Linkage, Disk and Lining).</i> Examine to see if ratchet, pawl and linkage are in good condition, secure, and not excessively worn, that disk is not scored or oily, and that lining is not oil soaked or worn too thin.
64		<i>Adjust.</i> Set clearance between brake disk and lining to $\frac{1}{16}$ inch when brake lever is released.

## 4- TO 5-TON 4x4 TRACTOR TRUCK (FEDERAL)

6,000 Mile Maint (3-6- month)	1,000 Mile Maint (1-3- day)	
65	65	<i>Clutch Pedal (Free Travel, Linkage, and Return Spring).</i> Check pedal free travel. Should be 1½ inches before meeting resistance. Examine to see if pedal is securely mounted to shaft, if clutch operating linkage is in good condition, secure and not excessively worn at friction joints. See if return spring has proper tension to bring pedal to correct released position.
65		<i>Adjust.</i> Adjust plate so clutch pedal free travel is to 1½ inches. <b>CAUTION:</b> <i>No pedal adjustment should be made. For correct procedure see paragraph 59.</i>
66	66	<i>Brake Pedal (Linkage and Return Spring).</i> Pedal should operate easily. Inspect all linkage to see if it is in good condition, securely connected, and not excessively worn at friction joints. Be sure return spring has tension to bring pedal to correct released position.
69	69	<i>Air Brake Application Valve.</i> See if application valve and linkage are in good condition, correctly assembled and secure; and that valve closes fully when brake pedal is released.
70	70	<i>Air Brake Reservoirs.</i> Observe whether they are in good condition and secure. Open the drain cocks and drain off condensate.
71	71	<i>Transmission (Mountings, Seals, Linkage).</i> Note if transmission case is in good condition, securely mounted and inspect for lubricant leaks at seals and gaskets. Examine control linkage and shift mechanism for damage or excessive wear.
72	72	<i>Transfer (Mountings, Linkage, Seals, Vent).</i> See if case is in good condition, securely mounted, that transmission and declutching control linkage and shift mechanism is securely connected and not damaged and if vent is open. Look for evidence of lubrication leaks at seals and gaskets. Clean vent passage if clogged. See that bond strap from transfer case to frame is secure.
72		<i>Tighten.</i> Draw up all external assembly and mounting nuts securely.
73	73	<i>Rear Propeller Shaft.</i> Inspect in same manner as in item 62.

## SECOND ECHELON PREVENTIVE MAINTENANCE

6,000 Mile Maint (Six- month)	1,000 Mile Maint (Month- ly)	
		<i>Tighten.</i> Draw up all U-joint and companion flange bolts securely.
75	75	<i>Rear Axle (Pinion End Play, Seals, Vent, and Alignment).</i> Inspect in the same manner as in item 61 for front axle. <i>Clean.</i> Clean axle housing vent thoroughly.
76	76	<i>Rear Air Brakes (Chambers, Rods, Seals, and Slack Adjusters).</i> See if all items are in good condition, securely connected and mounted. Examine rods for excessive wear and seals for lubricant leaks.
77	77	<i>Rear Springs (Clips, Leaves, U-Bolts).</i> Inspect and tighten in same manner as in item 56.
78	78	<i>Rear Shock Absorbers and Links.</i> Inspect in same manner as in item 58.
78		<i>Serve.</i> Service and make operating check in same manner as in item 58.
79	79	<i>Cab Mountings.</i> Note if they are all in good condition and secure. On cab mountings using coil springs, be sure springs are in good condition and properly compressed. These springs should be neither loose, nor compressed until solid. <i>Tighten.</i> Tighten cab mounting bolts securely, taking care to loosen the steering-column clamp before tightening. When tightening spring-loaded mounting bolts, do not compress springs fully. After completing this service, be sure to tighten steering-column clamp.
80	80	<i>Frame (Side and Cross Members).</i> Inspect frame, brackets, side rails, and cross members to see if they are in good condition, secure, and correctly aligned. If the frame appears to be out of line, report condition. See that oil bond straps connected to frame are in good condition and secure.
81	81	<i>Wiring, Conduit, and Grommets.</i> Observe these items underneath the vehicle, to see if they are in good condition, properly supported, connected, and secure.
82	82	<i>Fuel Tank, Fittings, and Lines.</i> Inspect fuel tank to see if it is in good condition and securely mounted. Examine cap for defective gasket or plugged vent. Remove strainer and clean thoroughly. See that filler neck is in

## 4. TO 5-TON 4x4 TRACTOR TRUCK (FEDERAL)

5,000 Mile Mark (1 1/2 month)	1,000 Mile Mark (1 month)	
82		good condition and that cap fits securely. Be sure bond strap from tank to bracket is secure.
83	83	Remove fuel tank drain plug and drain off accumulated water and dirt in bottom of tank. Drain only until fuel runs clear. Use necessary precautions against fire. <i>Brake Lines (Fittings and Hose).</i> Examine all lines and fittings and air brake hose under vehicle to see if they are in good condition, securely connected, and supported so lines or hose will not chafe against other vehicle parts.
84	84	<i>Exhaust Pipes and Muffler.</i> Examine exhaust pipe to see if it is securely attached to exhaust manifold, that gasket or packing does not show visible evidence of leakage, and that the other end is clamped securely to muffler. Inspect muffler to see if it is in good condition and securely mounted. Check tail pipe to see if it is securely clamped to muffler, properly supported, and unobstructed at its outer end. See that drain holes in muffler are at lowest point and not clogged.
85	85	<i>Vehicle Lubrication.</i> Lubricate all points of vehicle in accordance with instructions in vehicle, lubrication guide (pars. 16 and 17) and current lubrication bulletins or directives, and the following instructions: Use only clean lubricant. Keep all lubricant containers and dispensers covered except when withdrawing lubricant. Lubrication of items on the "Preventive Maintenance Service and Technical Inspection Work Sheet" that are marked with an "L" (special lubrication symbol) should be omitted on this "Vehicle Lubrication" service with the exception of the external lubrication cup of the distributor. This will avoid duplication and, in some cases, overlubrication. On all unsealed bushings or joints, lubricant should be applied until it appears at openings. On units such as universal joints, which are provided with lubricant-retainer seals, use an appropriate hand-operated grease gun and do not force lubricant beyond seals. Open any clogged lubrication passages until lubricant is properly delivered. When draining oil from engine, transmission, transfer case, or axle housings, always drain immediately after it has been warmed and agitated to a good draining con-

## SECOND ECHELON PREVENTIVE MAINTENANCE

6,000 Mile Maint (six- month)	1,000 Mile Maint (monthly)	
		<p>dition by operation of engine or vehicle. Refill units to correct level with specified oil as soon as draining is completed, so there will be little hazard that they may be operated without lubricant.</p> <p><b>CAUTION:</b> Do not fill to overflowing. Reinstall all drain and filter plugs securely. Take care that any required gaskets are in good condition and in place on the reinstalled plugs.</p> <p>Do not apply more than the specified amount of lubricant to generator, cranking motor, distributor, or water pump.</p> <p>Wipe off excess lubricant that may drip onto brakes, rubber parts, or detract from vehicle's appearance.</p> <p style="text-align: center;"><b>LOWER VEHICLE TO GROUND</b></p>
86	86	<p><b>Toe-in and Turning Stops.</b> With front wheels on ground and in straight ahead position use a toe-in gage to determine if adjustment is as specified. Should be <math>\frac{1}{8}</math> to <math>\frac{3}{16}</math> inch. Turn wheels fully in both directions and see if turn is limited by stops. In this position note if tires clear all parts of vehicle. If there is any indication turning angle exceeds specified limits (inside wheel 28°, outside wheel 24°) such as loose wheel stops, scuffing of tires against vehicle, or abnormal front-drive U-joint wear, report for check of turning angle by higher echelon.</p>
88	88	<p><b>Fifth Wheel (Bed Plate and Bolts).</b> Observe fifth-wheel rocker plate and bed plate to see if they are in good condition, securely assembled and mounted. Examine kingpin lock to see that it operates properly, locks securely and that kingpin latch is not excessively worn.</p> <p><b>Tighten.</b> Securely tighten all assembly and mounting bolts.</p> <p><b>Special Lubrication:</b> Clean fifth-wheel plate and lubricate with chassis lubricant. Lubricate all fifth wheel assembly grease fittings. Also hand-pack lubricant into latching mechanism. <b>CAUTION:</b> When a trailer is not attached, cover the fifth wheel to prevent accumulation of dirt.</p>
89	89	<p><b>Tractor to Trailer Brake Hose and Connections.</b> Examine brake hose to see if they are in good condition, properly supported, and if connecting fittings are in good condition and not excessively worn.</p>



## 4- TO 5-TON 4x4 TRACTOR TRUCK (FEDERAL)

6,000 Mile Mint (512- month)	1,000 Mile Mint (1mon- thly)	
91	91	<i>Lamps (Lights) (Head, Tail, Body, Stop, and Blackout).</i> Operate all switches and note if lamps respond. Include stop and blackout lamps. See if foot switch controls head lamp beams properly and if beams are aimed so as not to blind oncoming traffic. Examine all lights to see if they are in good condition and securely mounted and whether lenses are dirty or reflectors discolored.
91		<i>Adjust Lamp Unit Beams.</i>
92	92	<i>Safety Reflectors.</i> See if they are all present, in good condition, clean, and secure.
93	93	<i>Front Bumper Tow Hooks, Brush Guards and Grille.</i> See if they are in good condition, secure, and that radiator grille is not obstructed.
94	94	<i>Hood and Fasteners.</i> Inspect engine hood (cover) in cab to see if it is in good condition and that fasteners operate properly and hold hood securely.
95	95	<i>Front Fenders and Running Boards.</i> Examine fenders, running boards and steps to cab to see if they are in good condition and securely mounted.
96	96	<i>Cab (Doors, Hardware, Windshield and Glass, Top and Frame, Side Curtains, Seats, Gun Racks, Grab Rails, Floor Boards, Ventilators, Platforms).</i> Inspect these items to see if they are in good condition and secure; that the hardware and ventilators operate properly and are adequately lubricated; and if the doors engage their bumpers and strikers and latch properly in the closed position. See that the doors are properly aligned with their openings. Be sure wood platforms over gas tank and rear of cab are securely bolted and not damaged.
98	98	<i>Circuit Breakers.</i> Observe if they are in good condition, clean, dry, and securely connected and mounted.
99	99	<i>Rear Splash Guards.</i> See that they are in good condition and securely mounted.
101	101	<i>Pintle Hook.</i> Examine pintle to see if it is in good condition and securely mounted to frame. Test pintle and latch to see if they operate properly, are adequately lubricated, and if lock pin is present and securely attached to chain. Pay particular attention for broken spring has bee drawbar.

## SECOND ECHELON PREVENTIVE MAINTENANCE

6,000 Mile Maint. (Six months)	1,000 Mile Maint. (Two thly)	
103	103	<i>Paint and Marking.</i> Examine paint of entire vehicle to see if it is in good condition, paying particular attention to any bright spots in finish that might cause glare or reflection. Inspect vehicle markings and identification for legibility. Include identification plates and their mountings if furnished.
104	104	<i>Radio Bonding (Suppressors, Filters, Condensers and Shielding).</i> See that all radio noise suppression devices not covered in the foregoing specific procedures are in good condition and securely mounted or connected. Be sure all additional noise suppression bond straps and toothed lock washers listed in (pars. 181 and 185) are inspected for looseness and damage and see that contact surfaces are clean. NOTE: <i>If objectionable radio noise from vehicle has been reported, make tests in accordance with (pars. 181 and 185). If clearing and tightening of mountings and connections, and replacement of defective noise suppression units, does not eliminate the trouble, the radio operator involved will report the condition to the designated individual in authority.</i>
<b>TOOLS AND EQUIPMENT</b>		
131	131	<i>Tools (Vehicle and Pioneer).</i> Inspect standard vehicle and pioneer tools to see if they are all present (see vehicle stowage list) in good condition, clean, and properly stowed or securely mounted, and if tool box is in good condition and securely mounted and locked. Also examine tools which have cutting edges to see that they are sharp. Any tools mounted on outside of vehicle which have bright or polished surfaces, should be painted or otherwise treated to prevent rust, glare, or reflection.
132	132	<i>Fire Extinguisher.</i> See if it is in good condition, securely mounted, and fully charged. The charge may be determined on gas-type extinguishers by weighing with a scale, and on liquid-type by shaking. Also be sure nozzles are free from corrosion.
133	133	<i>Decontaminator.</i> See if it is in good condition, securely mounted and fully charged. Make the latter check by

## 4- TO 5-TON 4x4 TRACTOR TRUCK (FEDERAL)

6,000 Mile Exam (six- month)	1,000 Mile Exam (monthly)	
		removing filler plug. <b>NOTE:</b> <i>This solution must be replaced every three months as it deteriorates.</i>
134	134	<i>First Aid Kit (if specified).</i> See if it is in good condition, and that all of its items are present and properly packed. Report any deficiencies immediately.
135	135	<i>Publications and Form No. 26.</i> See that the vehicle manuals and lubrication guide, Form No. 26 (accident report) and W.D., AGO Form No. 478 (MWO and Major Unit Assembly Replacement Record), are present, legible and properly stowed.
136	136	<i>Traction Devices (Chains).</i> Examine tire chains to be sure they are in good condition, clean (if not in use) not excessively worn, protected against rust, and properly mounted or stowed.
137	137	<i>Tow (Chains, Cables, Rope, Snatch Blocks).</i> See if the provided towing devices are in good condition, clean, and properly stowed. Tow chains or cables should be properly protected against rust when not in use. If snatch blocks are furnished, check to see that they operate freely.
139	139	<i>Fuel and Water Cans and Brackets.</i> Observe if they are in good condition, secure, if the caps fit tightly and are secured to the cans with a chain, and if cans are leaking.
141	141	<i>Modifications (MWO Completed).</i> Inspect vehicle to determine if all Field Service Modification Work Orders have been completed, and enter all modifications or major unit assembly replacements made at time of this service on Form No. 478.
142	142	<i>Final Road Test.</i> Make a final road test rechecking items 2 to 15 inclusive, and also be sure to recheck the transmission, transfer case, and all driving axles to see that the lubricant is at the correct level and not leaking. Confine this road test to the minimum distance necessary to make satisfactory observations. <b>NOTE:</b> <i>Correct or report all deficiencies found during final road test.</i> <b>CAUTION:</b> <i>Be sure all inspection plates on cab, cowl, floor, plates, and battery covers are replaced and securely fastened.</i>

## Section XI

### ORGANIZATION TOOLS AND EQUIPMENT

#### 23. TOOL SETS.

a. **Standard Tool Sets.** The tool sets available to individuals (specialists) and organizations, dependent upon the allocation in the table of equipment, are listed in SNL N-19. The components of these tool sets are also listed and illustrated.

b. **Special Tool Set.** The special tools available for organizational maintenance establishments are listed in the Organizational Spare Parts and Equipment List of SNL G-510.

---

## Section XII

### TROUBLE SHOOTING

#### 24. GENERAL.

a. This section contains trouble shooting information and tests which can be made to help determine the causes of some of the troubles that may develop in trucks used under average climatic conditions (above 32°F.). Each symptom of trouble given under the individual unit or system is followed by a list of possible causes of the trouble. The tests necessary to determine which one of the possible causes is responsible for the trouble are explained after each possible cause.

#### 25. ENGINE.

a. **Engine Will Not Turn.**

(1) **HYDROSTATIC LOCK OR SEIZURE.** Remove spark plugs (par. 83 b) and attempt to turn engine with hand crank to check for excess fuel or oil in cylinders. If engine turns, the lock will be relieved. If engine does not turn, test for jammed cranking motor throw-out mechanism (step (2) below).

(2) **CRANKING MOTOR THROW-OUT MECHANISM JAMMED.** Remove cranking motor (par 89 b). Clean grease and dirt from throw-out mechanism. Inspect mechanism for broken parts. Replace broken parts and install cranking motor (par. 89 e). If engine still will not turn, seizure due to internal damage is indicated. Notify higher authority.

(3) **INCORRECT OIL VISCOSITY.** Drain crankcase and refill with proper grade oil (par. 17).

**4- TO 5-TON 4x4 TRACTOR TRUCK (FEDERAL)****h. Engine Turns but Will Not Start.**

(1) **INOOPERATIVE FUEL SYSTEM.** Remove fuel line from carburetor. With ignition switch off, turn engine over with the cranking motor. If free flow of fuel is not evident, fuel is not reaching carburetor (par 27 a). If fuel flows freely, trouble in the carburetor is indicated. Replace faulty carburetor (par. 62 e).

(2) **INOOPERATIVE IGNITION SYSTEM.** Remove a cable from a spark plug. Turn on ignition switch. Hold spark plug cable terminal  $\frac{1}{4}$  inch from engine casting and crank engine. If spark does not jump the  $\frac{1}{4}$ -inch gap, the ignition is inadequate (par. 30 a).

(3) **SLOW CRANKING SPEED** (par. 31 e).

**c. Engine Does Not Develop Full Power.**

(1) **IMPROPER IGNITION** (par. 30 a).

(2) **ENGINE OVERHEATED** (par. 29 a).

(3) **IMPROPER VALVE ADJUSTMENT.** Check clearance and adjust if necessary (par. 50 e).

(4) **USE OF IMPROPER TYPE OF FUEL** (par. 61).

(5) **PREIGNITION.** If proper octane fuel is being used and the ignition system is functioning satisfactorily, spark plug of improper heat range may be the cause of the trouble (par. 83 a and c). Otherwise internal engine troubles would be indicated. Notify higher authority.

(6) **AIR LEAKS AT CARBURETOR OR MANIFOLD FLANGES.** With engine running at 800 revolutions per minute, apply a small amount of oil at carburetor and manifold flange gaskets. If oil is sucked in, there is evidence of a leak. Tighten flange bolt nuts and test again. If leak persists, replace gaskets.

(7) **LOW ENGINE COMPRESSION OR IMPROPER VALVE TIMING.** If the engine does not develop full power with fuel reaching combustion chambers, adequate ignition and the proper grade and quantity of oil in crankcase, low compression or improper valve timing would be indicated. Notify higher authority.

(8) **INCORRECT GOVERNOR SETTING.** Disconnect governor linkage at the carburetor and check for spring linkage or stuck throttle. If throttle and linkage operate freely, start and accelerate the engine with the governor disconnected. If a speed of 2,400 revolutions per minute is reached, the governor is faulty. Refer to higher authority for repairs.

**d. Engine Misfires.**

(1) **FAULTY IGNITION SYSTEM** (par. 30 a).

(2) **LOW ENGINE COMPRESSION** (step (7) above).

(3) **INCORRECT CARBURETOR ADJUSTMENT.** Adjust carburetor (par. 62 b).

(4) **CLOGGED FUEL TANK CAP VENT.** Open vents or replace cap.

(5) **RESTRICTED FUEL FLOW** (par. 66 b).

## TROUBLE SHOOTING

(6) **WATER IN FUEL.** Remove drain plug from bottom of carburetor and inspect for water. If water is present, drain all fuel from system and refill with pure gasoline.

### e. Excessive Oil Consumption.

(1) **OIL VISCOSITY TOO LOW.** Drain crankcase and refill with proper oil (par. 17).

(2) **EXTERNAL OIL LEAKS.** Inspect for oil leaks at oil connections and at gaskets. Tighten loose connections. If leakage is detected at oil pan gasket or at main bearing flanges, notify higher authority.

(3) **PISTON RINGS WORN OR DAMAGED.** If high oil consumption continues with proper oil in crankcase and with no external leaks, faulty piston rings are indicated. Blue smoke in the exhaust also indicates worn or damaged piston ring. Notify higher authority.

### f. Engine Will Not Stop.

(1) **DEFECTIVE IGNITION SWITCH.** Replace switch (par. 84 h).

(2) **ENGINE OVERHEATED** (par. 29 a).

## 26. CLUTCH.

### a. Clutch Slips.

(1) **CLUTCH OUT OF ADJUSTMENT.** Adjust clutch (par. 59).

(2) **CLUTCH PEDAL OR LINKAGE BENT OR BINDING.** Disconnect linkage and inspect for bent or binding part. Replace defective parts (par. 60 a).

(3) **CLUTCH WORN OR BROKEN INTERNALLY.** If linkage is in satisfactory condition and slippage cannot be removed through adjustment, internal wear or breakage is indicated. Notify higher authority.

### b. Clutch Grabs.

(1) **LOOSE MOUNTING.** Tighten external mounting nuts.

(2) **INTERNAL DIFFICULTY.** If tightening external mounting nuts fails to remove trouble, internal difficulty is indicated. Notify higher authority.

### c. Clutch Rattles.

(1) **LOOSE OR WORN CONTROL LINKAGE.** Inspect clutch linkage. Replace worn parts. Tighten loose parts.

(2) **INTERNAL DIFFICULTY.** If rattle persists with linkage in satisfactory condition, internal difficulty is indicated. Notify higher authority.

### d. Clutch Will Not Release.

(1) **CLUTCH LINKAGE OUT OF ADJUSTMENT.** Bent or binding. Adjust clutch linkage to eliminate looseness (par. 60 b). Replace defective parts of linkage (par. 60 a).

(2) **CLUTCH OUT OF ADJUSTMENT.** Adjust clutch (par. 59).

(3) **INTERNAL DIFFICULTY.** If clutch cannot be adjusted to re-

**4- TO 5-TON 4x4 TRACTOR TRUCK (FEDERAL)**

lease and linkage is in satisfactory condition and adjustment, internal difficulty is indicated. Notify higher authority.

**c. Clutch Makes a Scrubbing Noise.**

- (1) **CLUTCH SLEEVE SCORED OR RIDGED.** Notify higher authority.

**27. FUEL SYSTEM.****a. Fuel Does Not Reach Carburetor.**

(1) **LACK OF FUEL.** Check gage on instrument panel and replenish fuel.

(2) **CLOGGED FUEL TANK VENT.** Remove obstruction from vent or replace cap.

(3) **INOPERATIVE FUEL PUMP; CLOGGED FUEL FILTER OR LINES.** Remove drain plug from fuel filter and check passage from tank by blowing through line. If obstruction is indicated, remove and clean fuel line. Service fuel filter. If passage to fuel pump is unobstructed, reconnect fuel line. Disconnect fuel line to carburetor from fuel pump. Turn engine over by means of cranking motor. If fuel does not flow from pump, a defective pump is indicated. Otherwise, the fuel line from pump to carburetor is obstructed. Repair or replace defective parts (par. 63 c).

**b. Fuel Does Not Reach Cylinders.**

(1) **CARBURETOR STRAINER CLOGGED.** Clean strainer or replace carburetor (par. 62 c).

(2) **THROTTLE NOT OPENING.** Adjust throttle (par. 62 b (2)).

(3) **CARBURETOR JETS CLOGGED.** Replace carburetor (par. 62 c).

**28. INTAKE AND EXHAUST SYSTEMS.****a. Air Passage to Carburetor Restricted.**

(1) **AIR CLEANER DIRTY.** Service air cleaner (par. 68 b).

(2) **AIR PIPE CRUSHED.** Visually inspect air pipe. Replace if damaged (par. 68 c).

**b. Dirt Laden Air Entering Carburetor.**

(1) **AIR CLEANER DIRTY.** Service air cleaner (par. 68 b).

(2) **NO OIL IN AIR CLEANER.** Service air cleaner (par. 68 b).

(3) **AIR PIPE DISCONNECTED OR LOOSELY CONNECTED.** Connect air pipe tightly (par. 68 d).

**c. Exhaust Makes Excessive Noise and/or System Emits Unpleasant Gas.**

(1) **MANIFOLD GASKETS LEAKING.** Visually inspect gaskets with engine running. If gaskets are leaking, tighten manifold attaching nuts. If leak persists, notify higher authority.

(2) **LEAK AT EXHAUST PIPE FLANGE.** Visually inspect connection with engine running. If gasket leaks, tighten nuts. If leak persists, replace gasket (par. 69 b).

(3) **EXHAUST PIPE BROKEN OR BENT AND PULLED FROM MUFFLER.**

## TROUBLE SHOOTING

Visually inspect pipe with engine running. Replace pipe if broken or bent (par. 69 b).

(4) **TAIL PIPE PULLED FROM MUFFLER, LOST OR BROKEN.** Visually inspect tail pipe. Connect if disconnected. Replace if lost or broken (par. 71 b).

(5) **MUFFLER DEFECTIVE.** If other parts of system are in satisfactory condition and excessive noise persists, a defective muffler is indicated. Replace muffler (par. 70 b).

### 29. COOLING SYSTEM.

#### a. Engine Overheats.

(1) **INSUFFICIENT COOLANT.** Check quantity of coolant and fill cooling system (par. 72 a).

(2) **FAN BELT LOOSE OR BROKEN.** Inspect fan belt. Replace if broken (par. 78 c). Adjust tension if loose (par. 78 b).

(3) **THERMOSTAT STICKING SHUT.** Remove (par. 76 c) and test thermostat by dropping it in water heated to 180 F. If it fails to open, replace it.

(4) **COOLING SYSTEM CLOGGED.** Fill system to capacity. Start and accelerate engine. Water flowing from the radiator overflow indicates a clogged radiator. Flush system.

(5) **WATER PUMP INOPERATIVE.** Disconnect upper hose connection (par. 73 b). Fill both engine and radiator as full as possible with hose disconnected. Start engine. If water fails to flow from upper hose connection for a brief period, an inoperative water pump is indicated. Replace water pump (par. 74 b).

(6) **CAUSED BY CONDITION EXTERNAL TO COOLING SYSTEM.** Some conditions external to cooling system which can cause engine overheating are, incorrect ignition timing, dragging brakes, insufficient lubrication, and incorrect valve timing. If the cause for overheating cannot be isolated within the cooling system, check each of these.

#### b. Engine Slow To Warm Up.

(1) **THERMOSTAT DEFECTIVE.** Remove thermostat (par. 76 c). Replace it if it is open at room temperature.

(2) **TEMPERATURE GAGE DEFECTIVE.** If this condition should exist, the gage might indicate a cold engine while the engine would really be warm. If this condition is suspected, remove the instrument and install one known to be accurate.

#### c. System Leaks Coolant.

(1) **DEFECTIVE HOSE CONNECTION.** Inspect hose connection. Tighten leaking connections. If leak persists, replace hose (par. 75 b).

(2) **WATER PUMP PACKING WORN.** This condition is indicated by leakage from water pump. Refer to higher authority.

(3) **RADIATOR CORE LEAKING.** Visually inspect core. Replace radiator if leak is detected (par. 73 b). Refer radiator to higher authority for repair.



## 4- TO 5-TON 4x4 TRACTOR TRUCK (FEDERAL)

## 30. IGNITION SYSTEM.

## a. Improper Ignition.

(1) **SPARK PLUGS FAULTY.** Uneven operation at idle speed, misfiring at high speed, or loss of power may be due to faulty spark plugs. Remove and inspect spark plugs (par. 83 h and c). Replace faulty plugs.

(2) **DISTRIBUTOR POINTS FAULTY.** Hard starting or complete failure to start on the part of the engine may be due to faulty distributor points. Remove distributor cap and inspect points. Measure gap. Crank engine and observe opening and closing of points. Adjust points if out of adjustment (par. 82 h). Replace points if pitted, burned, or broken (par. 82 h). Replace distributor if mechanical action of opening and closing mechanism is out of order (par. 82 c). Refer old distributor to higher authority for repair or rebuilding.

(3) **IGNITION COIL OR CONDENSER FAULTY.** Weak or no spark, with fully charged battery and serviceable spark plugs and distributor points installed, may indicate a faulty ignition coil or condenser. Remove suspected coil and or condenser and replace it with a part known to function properly (par. 80 h and or 81 h).

(4) **IGNITION FILTER FAULTY.** If check of other components of system fails to locate trouble, a faulty filter in ignition system is indicated. Test filter (par. 182 b) and replace (par. 182 c) if faulty.

## 31. STARTING AND GENERATING SYSTEMS.

## a. Low Generator Output.

(1) **BATTERY FULLY CHARGED.** This is a natural condition due to the action of the voltage regulator. No repair is necessary.

(2) **DIRT ON COMMUTATOR.** Remove inspection cover from generator. If dirt can be seen on commutator bars, start engine and hold a piece of 2 0 flintpaper against bars. Blow dust from generator with a blast of dry compressed air.

(3) **BRUSHES WORN.** Inspect brushes (par. 87 h). Replace if they are so worn that they no longer fit snugly in their holders (par. 87 h).

(4) **THIRD BRUSH INCORRECTLY SET.** Adjust generator output (par. 87 h). If this procedure rectifies the trouble, no further correction is necessary.

(5) **VOLTAGE REGULATOR OUT OF ADJUSTMENT.** If none of the causes enumerated above is at fault, improper adjustment of the voltage regulator is indicated. Replace voltage regulator (par. 88 h).

(6) **CAUSES EXTERNAL TO GENERATOR.** Low generator output could be caused by high resistance in either the battery or wiring between the generator and the batteries, or by a faulty field filter, supply filter, or generator capacitor. Check all wiring connections to be sure they are clean and tight. Check filters (par. 182 h) and replace capacitor with one known to function correctly (par. 183 h).

**TROUBLE SHOOTING**

Test individual wires with a test lamp. If trouble persists, replace the batteries (par. 155 c).

**b. Unsteady or No-generator Output.**

(1) **DIRT ON COMMUTATOR** (step (2) above).  
(2) **BRUSHES WORN** (step (3) above).  
(3) **SHORTED, OPEN, OR GROUNDED WIRING: LOOSE, OPEN, OR DIRTY CONNECTION.** Inspect all wiring. Use test lamp to test individual wires. Clean and tighten all connections. Replace or repair broken or poorly insulated wires.

(4) **VOLTAGE REGULATOR INOPERATIVE.** Replace voltage regulator (par. 88 h).

(5) **FAULTY RADIO NOISE SUPPRESSION UNIT.** Short out supply and field filters one at a time. Disconnect generator capacitor. Replace unit which proves defective (filter, par. 182 c; capacitor, par. 184 c).

**c. High Generator Output.**

(1) **LOW BATTERY.** Test battery with a hydrometer. If specific gravity is below 1.275, high generator output is normal. No repair is necessary.

(2) **HIGH RESISTANCE WIRING.** Inspect wiring. Use test lamp on individual wires. Clean and tighten all connections. Replace wires found to be defective.

(3) **OVERHEATED BATTERY.** Feel of battery case. If battery feels hot, allow it to cool. Add water before using battery again (par. 155 b).

(4) **VOLTAGE REGULATOR INOPERATIVE.** Replace voltage regulator (par. 88 b).

(5) **SHORTED OR GROUNDED GENERATOR FIELD CIRCUIT.** If none of the above are the cause of the difficulty a shorted or grounded field circuit is indicated. Replace generator (par. 87 c) and refer old generator to higher authority for repair.

**d. Noisy Generator.**

(1) **MOUNTING BOLTS LOOSE.** Attempt to tighten mounting bolts. If trouble disappears upon tightening, no further correction is necessary.

(2) **LACK OF LUBRICATION.** Lubricate generator (par. 17). If noise disappears, no further correction is necessary.

(3) **WORN COMMUTATOR OR BEARINGS.** If noise persists after tightening and lubricating, replace generator (par. 87 c).

**e. Cranking Motor Inoperative.**

(1) **DISCHARGED BATTERY.** Check battery (par. 155 b).

(2) **BROKEN BATTERY CABLE OR TERMINAL.** Inspect cables from batteries to ground, and from batteries to cranking motor. Replace broken cables (par. 92 c).

(3) **INOPERATIVE SWITCH.** Short circuit terminals of switch with

#### 4. TO 5-TON 4x4 TRACTOR TRUCK (FEDERAL)

a heavy metal tool pressed firmly across terminals. If cranking motor operates, an inoperative switch is indicated. Replace switch (par. 91 b).

(4) **INTERNAL DEFECT IN CRANKING MOTOR.** Disconnect cable from cranking motor. Press on cranking motor switch. Touch end of cable to frame of vehicle for an instant. Presence of sparks indicates inoperative cranking motor has internal defect. Replace cranking motor (par. 89 b).

### 32. TRANSMISSION.

#### a. Transmission Noisy.

(1) **INCORRECT OR INSUFFICIENT LUBRICANT.** Check lubricant and lubricate if necessary (par. 17).

(2) **TRANSMISSION CASE LOOSE ON CLUTCH HOUSING.** Tighten housing. If noise disappears, further corrective measures are unnecessary.

(3) **CLUTCH HOUSING LOOSE ON ENGINE.** Tighten housing. If noise disappears, condition is corrected.

(4) **INTERNAL DEFECT.** If noise persists after above measures have been taken, report trouble to higher authority.

#### b. Gears Slip Out of Mesh.

(1) **INTERNAL DEFECT.** Report condition to higher authority.

#### c. Lubricant Leaks From Case.

(1) **LOOSE CASE BOLTS.** Tighten case. If trouble disappears, further correction is unnecessary.

(2) **INTERNAL DEFECT.** Report condition to higher authority.

### 33. TRANSFER CASE.

#### a. Transfer Case Noisy.

(1) **LOOSE MOUNTING.** Tighten mounting. If trouble ceases, further correction is unnecessary.

(2) **INCORRECT OR INSUFFICIENT LUBRICANT.** Check lubricant and lubricate if necessary (par. 17).

(3) **CONNECTING PROPELLER SHAFT LOOSE.** Tighten propeller shaft. If noise stops, no further correction is needed.

(4) **INTERNAL DEFECT.** If noise persists after the above checks, report the condition to higher authority.

b. **Transfer Case Slips Out of Gear.** If linkage is broken or out of adjustment, inspect linkage. Replace broken parts. Adjust linkage (par. 98).

#### c. Transfer Case Leaks Lubricant.

(1) **LOOSE HOUSING.** Tighten housing bolts. If trouble stops, no further correction is needed.

(2) **INTERNAL DEFECT.** Report condition to higher authority.

## TROUBLE SHOOTING

### 34. PROPELLER SHAFTS AND UNIVERSAL JOINTS.

#### a. Propeller Shaft Rattles When Vehicle is Coasting.

(1) **WORN SPLINES OR BEARING CUPS.** Replace propeller shaft and attached universal joints (pars. 102 a, 103 a, and 104 a). Refer old shaft to higher authority for repair.

#### b. Propeller Shaft Vibrates.

(1) **LOOSE BOLTS AT UNIVERSAL JOINT COMPANION FLANGES.** Tighten loose bolts.

(2) **PROPELLER SHAFT OUT OF BALANCE OR MISALIGNED.** Replace propeller shaft and attached universal joints (pars. 102 a, 103 a, and 104 a). Refer old assembly to higher authority for repair.

#### c. Backlash in Propeller Shaft.

(1) **WORN BEARING IN UNIVERSAL JOINT.** Replace assembly (pars. 102 a, 103 a, and 104 a). Refer old part to higher authority for repair.

(2) **LOOSE BOLTS AT UNIVERSAL JOINT COMPANION FLANGES.** Tighten loose bolts.

### 35. FRONT AXLE.

#### a. Continuous Humming Noise.

(1) **LACK OF LUBRICATION.** Lubricate properly (par. 17).

(2) **WHEEL BEARINGS TOO TIGHT.** Adjust wheel bearing (par. 135 b).

(3) **BEVEL OR SPUR PINION BEARINGS TOO TIGHT.** Notify higher authority.

#### b. Humming Noise Noticeable Only When Coasting.

(1) **WHEEL BEARINGS WORN.** Replace wheel bearings (par. 135 c).

(2) **INTERNAL PARTS WORN OR OUT OF ADJUSTMENT.** Notify higher authority.

#### c. Humming Noise Noticeable Only When Pulling.

(1) **INCORRECT BACKLASH ADJUSTMENT BETWEEN BEVEL GEAR AND PINION.** Notify higher authority.

(2) **INTERNAL PARTS WORN OR OUT OF ADJUSTMENT.** Notify higher authority.

#### d. Backlash Noticeable in Front Wheels When Stopping and or Starting.

(1) **PROPELLER SHAFT LOOSE.** Tighten propeller shaft.

(2) **INTERNAL PART WORN OR MALADJUSTED.** Notify higher authority.

#### e. Lubricant Leaks From Housing.

(1) **LOOSE HOUSING BOLTS.** Tighten loose housing bolts.

(2) **DEFECTIVE GASKET, OIL SEAL, OR GREASE RETAINER.** Notify higher authority.

**4- TO 5-TON 4x4 TRACTOR TRUCK (FEDERAL)**

**36. REAR AXLE.**

**a. Continuous Humming Noise.**

(1) **LACK OF OR IMPROPER LUBRICATION.** Lubricate properly (par. 17).

(2) **BEARINGS TOO TIGHT.** Notify higher authority.

**b. Humming Noise Noticeable Only When Coasting.**

(1) **WORN BEARINGS OR INCORRECT BEVEL GEAR AND PINION ADJUSTMENT.** Notify higher authority.

**c. Humming Noise Noticeable Only When Pulling.**

(1) **INCORRECT BEVEL GEAR AND PINION ADJUSTMENT.** Notify higher authority.

**d. Backlash Noticeable When Stopping and/or Starting.**

(1) **LOOSE PROPELLER SHAFT.** Tighten propeller shaft (pars. 102 b, 103 b, and 104 b).

(2) **CLUTCH OUT OF ADJUSTMENT OR WORN.** Adjust clutch. If trouble persists, notify higher authority.

(3) **INTERNAL MALADJUSTMENT OR WEAR.** Notify higher authority.

**e. Lubricant Leaks From Housing.**

(1) **LOOSE HOUSING BOLTS.** Tighten loose bolts.

(2) **WORN OR DAMAGED GASKET, OIL SEAL, OR GREASE RETAINER.** Notify higher authority.

**37. SERVICE BRAKE SYSTEM.**

**a. Brake Pedal Goes to Floor Board.**

(1) **NORMAL WEAR OF BRAKE LINING.** Adjust brakes (par. 127 b). If worn so that adjustment fails to eliminate trouble, notify higher authority.

(2) **LOW AIR PRESSURE.** Observe pressure as indicated on gage. If less than 105 pounds, start engine and build up pressure. Should pressure fail to build up, check system for leaks or inoperative units.

(3) **WATER TRAPPED IN AIR SYSTEM.** Drain reservoir tank (par. 115 b).

**b. Brakes Drag.**

(1) **BRAKE CONTROL ROD ADJUSTED TOO SHORT.** Remove clevis pin and loosen lock nut. Turn yoke counterclockwise to lengthen rod. Tighten lock nut and connect rod.

(2) **BRAKE CONTROL ROD RETURN SPRING WEAKENED OR BROKEN.** Remove spring from control rod and brake application valve bracket. Replace with serviceable spring.

(3) **WATER TRAPPED IN SYSTEM.** Drain reservoir tank (par. 115 b).

**c. One Brake Drags.**

(1) **GREASE IN BRAKE LINING.** Replace brake shoes (par. 128 c).

## TROUBLE SHOOTING

Return old shoes to third echelon for relining. Check condition of grease retainers. Replace if defective.

(2) **BRAKE SHOES OUT OF ADJUSTMENT.** Adjust brakes (par. 127 b).

(3) **LINING LOOSENED FROM SHOE.** Replace brake shoes (par. 128 c).

(4) **BRAKE SHOE SPRING WEAKENED OR BROKEN.** Replace brake shoe spring (par. 128 e).

(5) **CLOGGED AIR TUBE OR HOSE.** Clean or replace obstructed part.

(6) **BRAKE ANCHOR PIN TIGHT.** Replace brake anchor pin (par. 128 e).

(7) **WHEEL BEARINGS OUT OF ADJUSTMENT.** Adjust wheel bearings (par. 135 b).

**d. Truck Pulls to Right or Left When Brakes Are Applied and/or Brakes Are Uneven.**

(1) **BRAKE ON FRONT WHEEL DRAGGING** (subpar. c above).

(2) **BRAKES NEED ADJUSTING OR LUBRICATING.** Adjust (par. 127 h) and/or lubricate (par. 17) brakes.

(3) **BRAKES NEED RELINING.** Report to higher authority.

(4) **GREASE ON BRAKE LINING.** Report to higher authority.

(5) **BRAKE SHOE RELEASE SPRING OR BRAKE DIAPHRAGM CHAMBER RELEASE SPRING BROKEN.** Replace broken spring.

(6) **BRAKE DRUM OUT-OF-ROUND.** Replace drum (par. 135 d).

(7) **LEAKING BRAKE CHAMBER DIAPHRAGM.** Replace diaphragm (par. 123 b).

**e. Brakes Take Hold Slowly.**

(1) **BRAKES OUT OF ADJUSTMENT.** Adjust brakes (par. 127 b).

(2) **BRAKE LINING WORN.** Replace brake shoes (par. 128 c).

(3) **BRAKE DRUMS WORN.** Replace drums (par. 135 d). Return used parts to higher authority for repair.

(4) **RESTRICTION IN AIR LINE.** Remove obstruction from air line or hose, or replace offending part.

(5) **BRAKE MECHANISM NEEDS LUBRICATION.** Lubricate vehicle (par. 17).

(6) **LOW AIR PRESSURE IN BRAKE SYSTEM** (subpar. k below).

(7) **BRAKE VALVE DELIVERY LOW.** Check brake valve delivery pressure. Adjust brake valve linkage or replace brake valve (par. 117 b).

(8) **EXCESSIVE LEAKAGE WITH BRAKES APPLIED** (subpar. o below).

(9) **RESTRICTION IN TUBING LINES.** Disconnect both ends of suspected line. Apply air pressure to blow out obstruction. Replace line if impossible to remove obstruction.

(10) **RESTRICTION IN HOSE LINE.** Disconnect both ends of suspected line. Apply air pressure to blow out obstruction. Replace line if impossible to remove obstruction.

## 4. TO 5-TON 4x4 TRACTOR TRUCK (FEDERAL)

## f. Brakes Release Slowly.

(1) **BRAKE CONTROL ROD NOT RETURNING PROPERLY.** Check adjustment of control rod. Adjust if necessary (par. 117 c). Check condition of brake control rod return spring. Replace spring if weak or broken.

(2) **RESTRICTION IN AIR TUBE OR HOSE.** Remove obstruction (par. 125 c) or replace faulty tube or hose (par. 125 b).

(3) **DEFECTIVE AIR VALVE.** Replace defective valve (par. 117 b).

(4) **BRAKE CAMSHAFT BINDING.** Lubricate brake cam with engine oil. Do not get oil on lining.

(5) **BRAKES NEED ADJUSTING OR LUBRICATING.** Adjust (par. 127 b) and/or lubricate (par. 17) brakes.

(6) **EXHAUST PORT OF BRAKE VALVE, QUICK RELEASE VALVE, OR RELAY VALVE OBSTRUCTED.** Remove obstruction.

(7) **DEFECTIVE BRAKE VALVE, QUICK RELEASE VALVE, OR RELAY VALVE.** Replace defective valve (pars. 117 b, 119 b, and 120 b respectively).

## g. Insufficient Brakes.

(1) **BRAKES NEED ADJUSTING, LUBRICATING, OR RELINING.** Adjust brakes (par. 127 b), lubricate (par. 17) brakes, or report to higher authority.

(2) **LOW AIR PRESSURE** (subpar. h below).

(3) **BRAKE VALVE DELIVERY PRESSURE LOW.** Check brake valve delivery pressure. Adjust valve linkage or replace valve (par. 117 b).

## h. Brakes Do Not Apply.

(1) **NO AIR PRESSURE.** Start engine and build up air pressure.

(2) **RESTRICTED OR BROKEN TUBING OR HOSE.** Disconnect both ends of restricted line and apply air pressure. Replace line, if impossible to remove obstruction or if line is broken.

(3) **DEFECTIVE BRAKE VALVE.** Replace valve (par. 117 b).

## i. Brakes Do Not Release.

(1) **BRAKE RIGGING BINDING.** Straighten or replace bent parts. Replace worn or broken parts. Lubricate rigging (par. 17).

(2) **BRAKE VALVE NOT RETURNING TO FULL RELEASED POSITION.** Adjust retracting spring tension. Check control rod and pedal to see if either is binding. Free and lubricate binding parts.

(3) **BRAKE VALVE IN APPLIED POSITION.** Move valve to released position.

(4) **BRAKE VALVE DEFECTIVE.** Replace valve (par. 117 b).

(5) **RESTRICTION IN TUBING OR HOSE.** Disconnect both ends of suspected line and blow out with compressed air. Replace line if impossible to remove obstruction.

(6) **AIR TRAPPED IN FRONT SERVICE LINE BEYOND DOUBLE CHECK VALVE.** This is caused by obstruction, or absence, of venthole

## TROUBLE SHOOTING

in dummy coupling. Clear venthole in dummy coupling or replace dummy coupling with one having venthole.

**j. Brakes Grab.**

- (1) GREASE ON LINING. Report to higher authority.
- (2) BRAKE DRUM OUT-OF-ROUND. Replace drum (par. 135 d).
- (3) DEFECTIVE BRAKE VALVE. Replace valve (par. 117 b).
- (4) BRAKE RIGGING BINDING. Straighten or replace bent parts. Replace broken and worn parts. Lubricate rigging (par. 17).

**k. Air Pressure Will Not Rise to Normal (80 to 105 pounds).**

- (1) DEFECTIVE AIR GAGE REGISTERING INCORRECTLY. Replace gage (par. 176 b).
- (2) EXCESSIVE LEAKAGE. Start engine and build up as much pressure as possible. Check all connections and units for leaks, with brakes applied and not applied. Use soapy water to detect leaks which cannot be felt or heard. Tighten loose connections and replace defective parts.
- (3) RESERVOIR TANK DRAIN COCK OPEN. Close drain cock on bottom of each tank.
- (4) GOVERNOR OUT OF ADJUSTMENT. Adjust governor (par. 114 b).
- (5) NO CLEARANCE AT COMPRESSOR UNLOADING VALVES. Adjust clearance to 0.010 inch minimum, 0.015 inch maximum (par. 113 b).
- (6) FAN BELTS SLIPPING ON COMPRESSOR PULLEY. Adjust fan belt tension (par. 78 b).
- (7) DEFECTIVE COMPRESSOR. Replace compressor (par. 113 r).

**l. Air Pressure Rises Too Slowly to Normal (80 to 105 pounds).**

- (1) EXCESSIVE LEAKAGE. Check for leakage and service or replace defective units.
- (2) CLOGGED COMPRESSOR AIR FILTER. Service air filter (par. 113 b).
- (3) NO CLEARANCE AT COMPRESSOR UNLOADING VALVES. Adjust clearance to 0.010 inch minimum, 0.015 inch maximum (par. 113 b).
- (4) ENGINE SPEED TOO LOW. Increase engine speed.
- (5) COMPRESSOR DISCHARGE VALVES LEAKING. Replace compressor (par. 113 r).
- (6) EXCESSIVE CARBON IN COMPRESSOR CYLINDER HEAD OR DISCHARGE LINE. Replace compressor, or discharge line (pars. 113 b and 125 c).

**m. Air Pressure Rises Above Normal (80 to 105 pounds).**

- (1) DEFECTIVE AIR GAGE REGISTERING INCORRECTLY. Replace gage (par. 176 b).
- (2) DEFECTIVE GOVERNOR. Replace governor (par. 114 c).
- (3) GOVERNOR OUT OF ADJUSTMENT. Adjust governor (par. 114 b).
- (4) RESTRICTION IN GOVERNOR TO COMPRESSOR TUBE. Discon-



## 4- TO 5-TON 4x4 TRACTOR TRUCK (FEDERAL)

nect both ends of tube and apply compressed air. If impossible to remove obstruction, replace tube.

(5) **TOO MUCH CLEARANCE AT COMPRESSOR UNLOADING VALVES.** Adjust clearance to 0.010 inch minimum, 0.015 inch maximum (par. 113 b).

(6) **UNLOADING VALVE CAVITIES OR UNLOADING PASSAGE BLOCKED WITH CARBON.** Replace compressor (par. 113 c).

(7) **UNLOADING VALVES STUCK CLOSED.** Replace compressor (par. 113 c).

**n. Air Pressure Drops Quickly With Engine Stopped and Brakes Released.**

(1) **LEAKING BRAKE VALVE.** Replace valve (par. 117 b).

(2) **LEAKING RELAY VALVE.** Replace valve (par. 117 b).

(3) **LEAKING TUBING OR HOSE.** Service or replace line (par. 125 b).

(4) **COMPRESSOR DISCHARGE VALVES LEAKING.** Replace compressor (par. 113 c).

(5) **GOVERNOR LEAKING.** Service or replace governor (par. 114 c).

(6) **EXCESSIVE LEAKAGE ELSEWHERE IN SYSTEM** (subpar. k (2) above).

**o. Air Pressure Drops Quickly With Engine Stopped and Brakes Fully Applied.**

(1) **LEAKING BRAKE CHAMBER DIAPHRAGMS.** Replace diaphragm chambers (par. 123 b).

(2) **LEAK IN BRAKE VALVE, RELAY VALVE, TUBING OR HOSE.** Service or replace leaking part.

(3) **DRAIN COCK OR CUT-OUT COCK LEFT OPEN.** Close cock.

**p. Compressor Knocks.**

(1) **LOOSE DRIVE PULLEY.** Tighten pulley.

(2) **BACKLASH IN DRIVE GEARS OR DRIVE COUPLING.** Report to higher authority or replace compressor (par. 113 c).

(3) **WORN BEARINGS.** Replace compressor (par. 113 c).

(4) **EXCESSIVE CARBON IN COMPRESSOR CYLINDER HEAD.** Replace compressor (par. 113 c).

**q. Brake Valve "Groans" When Brakes Are Applied.**

(1) **DEFECTIVE BRAKE VALVE.** Replace valve (par. 117 c).

**r. Relay Valve "Groans" or "Chatters" When Brakes Are Applied.**

(1) **DEFECTIVE RELAY VALVE.** Replace valve (par. 117 b).

**s. Quick Release Valve "Blats" When Brakes Are Released.**

(1) **DEFECTIVE QUICK RELEASE VALVE.** Replace valve (par. 117 b).

### TROUBLE SHOOTING

#### **l. Safety Valve Blows Off.**

- (1) **SAFETY VALVE OUT OF ADJUSTMENT.** Replace safety valve (par. 116 b).
- (2) **AIR PRESSURE ABOVE NORMAL** (subpar. m above).

### **38. PROPELLER SHAFT BRAKE SYSTEM.**

#### **a. Brake Does Not Hold.**

- (1) **BRAKE OUT OF ADJUSTMENT.** Adjust brake (par. 130 b).
- (2) **BRAKE LINING WORN.** Try adjusting brakes (par. 130 b). If trouble persists, replace shoes (par. 128 e).
- (3) **BRAKE SHOE LINING GLAZED OR GREASED.** Replace brake shoes (par. 130 c).
- (4) **BRAKE DRUM WORN AND/OR GLAZED.** Report trouble to higher authority.

### **39. WHEELS, HUBS, WHEEL BEARINGS, AND TIRES (par. 41).**

#### **a. Pounding or Squeaking Noise in Wheel.**

- (1) **WHEEL HUB STUD CAP NUTS LOOSE.** Tighten cap nuts securely (par. 134 e).
- (2) **TIRE MOUNTED OUT OF BALANCE.** Disassemble tire and assemble correctly (par. 136 e).

#### **b. Wheel Drags and Wheel Bearing Heats.**

- (1) **WHEEL BEARING ADJUSTED TOO TIGHT.** Adjust wheel bearing (par. 135 b).

#### **c. Tires Overheat.**

- (1) **TIRES UNDERINFLATED.** Inflate tires properly (par. 136 b).

#### **d. Excessive or Uneven Tire Wear.**

- (1) **TIRES INFLATED INCORRECTLY.** Inflate tires properly (par. 136 b).
- (2) **TOE-IN OUT OF ADJUSTMENT.** Adjust toe-in (par. 106 b).
- (3) **TIRES MOUNTED OUT OF BALANCE.** Remove tires and install correctly (par. 136 e).

### **40. SPRINGS AND SHOCK ABSORBERS.**

#### **a. Vehicle Bottoms or Skews.**

- (1) **BROKEN FRONT OR REAR SPRING.** Replace broken spring (pars. 137 b and 138 b).
- (2) **INOOPERATIVE SHOCK ABSORBER.** Replace inoperative shock absorbers (par. 139 d).

#### **b. Truck Exceptionally Hard Riding.**

- (1) **SPRINGS LACK LUBRICATION.** Lubricate vehicle (par. 17).
- (2) **SHACKLE PINS FROZEN IN SHACKLE.** Replace shackle pins (par. 137 b).

#### **c. Exaggerated Spring Action.**

- (1) **SHOCK ABSORBER INOPERATIVE.** Replace shock absorber (par. 139 e).

**4. TO 5-TON 4x4 TRACTOR TRUCK (FEDERAL)**

(2) **WORN SHACKLE PINS AND BUSHINGS.** Replace shackle pins, springs, and shackles (pars. 137 b and 138 b).

(3) **BROKEN SPRING REBOUND CLIPS.** Replace spring (pars. 137 b and 138 b).

**d. Springs Noisy.**

(1) **SHACKLE PINS AND BUSHINGS WORN.** Replace shackles, springs, and pins (pars. 137 b and 138 b).

(2) **SPRING REBOUND CLIPS LOOSE OR BROKEN.** Tighten loose clips. If clips are broken, replace spring.

(3) **BROKEN SPRING OR SHACKLE.** Replace broken part (pars. 137 b and 138 b).

**41. STEERING GEAR.****a. Front Wheels Shimmy.**

(1) **WHEEL AND TIRE OUT OF BALANCE.** Inspect tire. If incorrectly mounted (with valve and balancing mark on tire not aligned), dismount tire and assemble correctly (par. 136 e). If this does not remedy the trouble, refer the wheel and tire to higher authority for balancing.

(2) **DRAG LINK LOOSE.** Shake drag link. Tighten and adjust if loose (par. 143).

(3) **STEERING GEAR OUT OF ADJUSTMENT.** Adjust steering gear (par. 141).

(4) **STEERING GEAR WORN.** Refer to higher authority for repair.

(5) **FRONT WHEEL BENT.** Jack up front of truck. Spin wheels and look for wobble. Replace bent wheel (par. 134 h).

(6) **LOOSE FRONT WHEEL BEARINGS.** Jack up truck. Check bearings for play. Adjust loose bearing (par. 135 h).

(7) **FRONT TIRE, WHEEL AND OR HUB OUT OF BALANCE.** Jack up front of truck. Spin wheels repeatedly and notice if they always stop and rock at same point. If out of balance, check mounting of tire. Dismount and mount correctly if valve and balancing mark on tire are not aligned (par. 183 e). If trouble persists, refer entire assembly to higher authority for balancing.

(8) **IMPROPER CASTER OR CAMBER.** Notify higher authority.

(9) **BENT FRAME.** Notify higher authority.

**b. Front Wheel Wander.**

(1) **DRAG LINK LOOSE.** Shake drag link. Tighten and adjust if loose (par. 143).

(2) **WORN STEERING GEAR.** Refer to higher authority for repair.

(3) **FRAME OF VEHICLE BENT.** Notify higher authority.

**c. Vehicle Steers Hard.**

(1) **STEERING GEAR AND OR FRONT AXLE LACK PROPER LUBRICATION.** Lubricate vehicle correctly (par. 17).

(2) **TIRES UNDERINFLATED.** Inflate tires correctly (par. 136 h).

## TROUBLE SHOOTING

(3) **FRONT SPRING CLIPS LOOSE OR BROKEN.** Inspect front spring clips. Tighten if loose. If clips are broken, replace spring (par. 137 b and 138 b).

(4) **WORN STEERING GEAR.** Refer to higher authority for repair.

(5) **FRAME OF VEHICLE BENT.** Notify higher authority.

**d. Road Shocks Felt at Steering Wheel.**

(1) **DRAG LINK ADJUSTED TOO TIGHT.** Adjust drag link (par. 141).

(2) **WORN STEERING GEAR.** Refer to higher authority for repair.

**c. Truck Pulls to Right or Left.**

(1) **TIRES INFLATED UNEVENLY.** Inflate tires properly (par. 136 b).

**f. Vehicle Hard to Straighten Out After Turn to Right or Left.**

(1) **IMPROPER TIRE INFLATION.** Inflate tires properly (par. 136 b).

## 42. BODY AND FRAME.

**a. Windshield Wiper Inoperative.**

(1) **LEAK IN TUBING FROM MANIFOLD TO WIPER.** Start engine and inspect tubing. Place a liquid on doubtful spots. If it bubbles, a leak is indicated. Replace punctured or defective tubing.

(2) **KINKED HOSE OR TUBING.** Visually inspect tubing and hose. Straighten out kinks. Replace hose or tubing if it cracks or breaks.

(3) **DIRT ON EXTERIOR OF WIPER CASE BLOCKING AIR INTAKE.** Blow dirt from outside wiper motor case with compressed air.

(4) **INTERNAL DIRT OR WEAR.** Replace wiper (par. 146 c).

**b. Vehicle Steers Hard, Shimmies, Wanders, or Wheels Do Not Track.**

(1) **FRAME BENT.** Notify higher authority.

## 43. BATTERY AND LIGHTING SYSTEM.

**a. Battery Cells All Test Over 1.250 Specific Gravity.**

(1) **BATTERY NORMAL.** No corrective measures necessary in summer. For cold weather operation, give batteries booster charge if cells are under 1.275.

**b. Battery Cells All Test Under 1.250 Specific Gravity.**

(1) **BATTERY WILL NOT HOLD A CHARGE.** Replace battery (par. 155 c).

(2) **DEMAND FROM BATTERIES EXCEEDS INPUT FROM GENERATOR.** Recharge batteries. Check electrical system for short circuits, loose connections, and low generator output. Increase charging rate (par. 87 b).

**c. Frequent Additions of Water Necessary.**

(1) **EXCESSIVE GENERATOR CHARGING RATE.** Adjust generator charging rate (par. 87 b).

(2) **BROKEN BATTERY CASE.** Replace battery. Refer used battery to higher authority to repair.

**4- TO 5-TON 4x4 TRACTOR TRUCK (FEDERAL)****d. Bulge in Battery Case.**

(1) **EXCESSIVE TEMPERATURE DUE TO OVERCHARGING.** Adjust generator output (par. 87 b).

**e. Corrosion on Battery Terminals.**

(1) **EXCESSIVE CHARGING RATE CAUSING ACID TO SPRAY ON TERMINALS.** Remove terminals from posts. Clean posts and terminals thoroughly. Replace cable if terminal is weakened by corrosion. Connect terminals and apply a film of No. 2 general purpose grease or vaseline to exposed metal. Adjust generator output (par. 87 b).

(2) **LEAD COATING ON TERMINALS DESTROYED** (subpar. (1) above).

**f. Broken Terminal Post on Battery.**

(1) **LOOSE BATTERY INSTALLATION.** Replace battery (par. 155 c).

(2) **BATTERY CABLE TOO SHORT.** Replace battery and cable (pars. 155 c and 92 c).

**g. All Lamps Fail To Light.**

(1) **CIRCUIT BREAKS OPEN.** Close circuit breaker. If it snaps open again, look for short circuit.

(2) **BATTERIES DEAD.** Check for cause. Eliminate short circuits. Recharge or replace batteries.

(3) **OPEN CIRCUIT IN CABLE OR WIRES.** Visually inspect wiring. If visual inspection reveals no open circuit, locate with test lamp. Connect disconnected wires or cables. Replace broken wires or cables.

**h. One Lamp Fails To Light.**

(1) **BURNED OUT BULB.** Replace bulb.

(2) **BULB LOOSE IN SOCKET.** Install bulb properly.

(3) **OPEN CIRCUIT IN CIRCUIT TO LAMP** (subpar. g (3) above).

(4) **LIGHT NOT GROUNDED.** Remove light. Clean points of contact on light and vehicle until shiny. Install light.

**44. INSTRUMENTS.****a. Ammeter Inoperative.**

(1) **WIRE DISCONNECTED OR BROKEN.** Connect disconnected wire. Splice or replace broken wire.

(2) **INTERNAL DEFECT.** Check with one known to be right. Replace if found defective (par. 170 b).

**b. Fuel Gage. Apparently inoperative.**

(1) **NO FUEL IN TANK.** Fill fuel tank.

(2) **OPEN CIRCUIT IN WIRING.** Visually inspect wires to see if any are broken or disconnected. Use a test lamp if open circuit cannot be located visually. Connect disconnected wires and replace broken wires.

(3) **FUEL GAGE TANK UNIT INOPERATIVE.** Replace tank unit (par. 171 b).

(4) **GAGE INOPERATIVE.** Replace gage (par. 171 d).

**TROUBLE SHOOTING****c. Tachometer Pointer Noisy and/or Fluctuates and Jumps.**

(1) **FLEXIBLE SHAFT KINKED.** Examine cable. Remove kinks. Replace cable if permanently distorted (par. 172 b).

(2) **FLEXIBLE SHAFT WORN AND BINDING.** Replace cable (par. 172 b).

(3) **TACHOMETER HEAD WORN.** Replace tachometer head (par. 172 b).

**d. Tachometer Inoperative.**

(1) **FLEXIBLE SHAFT BROKEN.** Examine shaft and replace if broken (par. 172 b).

(2) **DRIVE UNIT INOPERATIVE.** Replace drive unit.

(3) **HEAD INOPERATIVE.** Replace tachometer head (par. 172 b).

**e. Speedometer Fluctuates and Jumps and or Is Noisy.**

(1) **CABLE KINKED.** Examine cable and eliminate kinks. Replace cable if permanently bent (par. 173 d).

(2) **CABLE WORN AND BINDING.** Replace cable (par. 173 d).

(3) **SPEEDOMETER WORN.** Replace speedometer (par. 173 b).

**f. Speedometer Inoperative.**

(1) **CABLE DISCONNECTED.** Connect cable (par. 173 a).

(2) **CABLE BROKEN.** Replace cable (par. 173 d).

(3) **DRIVE UNIT INOPERATIVE.** Replace drive unit.

(4) **INSTRUMENT INOPERATIVE.** Replace speedometer (par. 173 b).

**g. Oil Gage Apparently Inoperative.**

(1) **OIL PUMP INOPERATIVE OR ENGINE WITHOUT OIL PRESSURE FOR OTHER REASON.** Stop engine. Inspect oil lines to see if any are broken. Look for signs of oil leakage. Replace broken lines. If lines are apparently in satisfactory condition, an inoperative oil pump is indicated. Notify higher authority.

(2) **LINE TO GAGE PLUGGED.** Remove line and remove obstruction or replace line (par. 174 b).

(3) **GAGE DEFECTIVE.** Replace gage (par. 174 b).

**h. Temperature Gage Inoperative.**

(1) **TUBE BROKEN OR DISCONNECTED.** Trace tube from gage to left side of read cylinder head. Replace if broken. Connect if disconnected (par. 175 a).

(2) **GAGE DEFECTIVE.** Replace gage (par. 175 b).

**i. Air Pressure Gage Apparently Inoperative.**

(1) **NO AIR PRESSURE.** Start engine but do not drive truck. Buzzing of low-pressure buzzer indicates no or low air pressure. Let engine run until pressure builds up. If pressure fails to build up or if system fails to hold pressure, check tubing, hosing, fittings, and units in system for pressure or leaks. Tighten or replace leaking parts.

#### 4- TO 5-TON 4x4 TRACTOR TRUCK (FEDERAL)

(2) **OBSTRUCTION IN LINE TO GAGE.** Disconnect line from gage and run engine. If air fails to come from line, an obstruction is indicated. Disconnect tubing from fitting on engine side of air compressor. Disassemble two pieces of tubing from connecting hose. Remove obstruction or replace plugged tubing or hose.

(3) **DEFECTIVE GAGE.** If air is emitted from tubing (subpar. (2) above), a defective gage is indicated. Replace gage (par. 176 b).

**j. Viscosity Gage Apparently Inoperative.**

(1) **NO OIL IN CRANKCASE.** Check engine oil and add oil if necessary (par. 17).

(2) **VISCOSITY GAGE OIL LINE OBSTRUCTED.** Disconnect line at gage and at viscosity gage instrument, near rear of left side of oil pan. Attempt to blow through line. If plugged, remove obstruction or replace line.

(3) **VISCOSITY GAGE INSTRUMENT DEFECTIVE.** If line was unobstructed but empty a defective viscosity instrument is indicated. Remove instrument from near rear of left side of oil pan and replace with a serviceable unit.

(4) **VISCOSITY GAGE DEFECTIVE.** If tubing and instrument are in satisfactory condition, as determined in the two preceding steps, a defective gage is indicated. - Replace gage (par. 177 b).

#### 45. RADIO NOISE SUPPRESSION.

**a. Radio Interference: Noticeable With Engine Running and Vehicle Standing.**

(1) **IGNITION CIRCUIT NOISY.** Accelerate engine and turn off ignition switch. If crackling noise stops instant switch brakes circuit, a faulty ignition filter or resistor suppressors are indicated. Test filter (par. 182 b). Replace resistor suppressors (par. 184 c). Clean and tighten all connections in circuit.

(2) **REGULATOR NOISY.** If irregular clicking continues a moment after switch is shut off, a faulty field filter is indicated. Test filter (par. 182 b) and replace (par. 182 c) if defective. Clean and tighten all connections. Replace regulator if noise persists.

(3) **GENERATOR NOISY.** If whining noise varies with engine speed and continues a moment after switch is turned off, a noisy generator is indicated. Replace capacitor (par. 183 b). If trouble persists, test field filter (par. 182 b). Replace filter if defective (par. 182 c), clean and tighten all connections. Replace generator if noise persists.

**b. Radio Interference: Noticeable With Vehicle in Motion but Not Noticeable With Vehicle Standing, Engine Running.** This is due to faulty bond straps or bending bolts. Check all bond straps (par. 185 b) and bonding bolts for clean and tight connections. Tighten body and frame nuts. Replace all missing bond straps, bolts, washers, and nuts.