

## NOTICE

Be advised that this motor vehicle may be equipped with computer / recording devices. Their function is to allow an authorized individual to download data or information relating to the operation or performance of this vehicle.

The stored data or information may be neither downloaded nor retrieved except by the vehicle's registered owner, or, in the alternative, by another individual or entity authorized by the registered owner, such as an International Dealer, who may need this data or information to properly service or diagnose this vehicle for repair or following an accident.

Any access to this information without the owner's consent may be in violation of law and may subject that person or entity to criminal penalties.

## CALIFORNIA

### Proposition 65 Warning

Diesel engine exhaust and some of its constituents are known to the State of California to cause cancer, birth defects, and other reproductive harm.

Battery posts, terminals and related accessories contain lead and lead compounds, chemicals known to the State of California to cause cancer and reproductive harm.

Wash hands after handling.

### Important

The information, specifications, and illustrations contained in this manual are based on data that was current at the time of publication. International reserves the right to make changes and/or improvements at any time without notification or liability, or without applying those changes or improvements to vehicles previously manufactured.

-----  
*Make sure your use of this completed vehicle conforms to all federal, state and local requirements and regulations imposed on owners and operators.*

## Operator's Manual – PROSTAR®+ Series

### IMPORTANT

IT IS IMPORTANT THAT THE VEHICLE IDENTIFICATION NUMBER (VIN), AND COMPONENT FEATURE CODE AND SERIAL NUMBERS BE RECORDED. THESE NUMBERS ARE REQUIRED TO OBTAIN INFORMATION PERTINENT TO THIS VEHICLE.

#### VIN (VEHICLE IDENTIFICATION NUMBER) LOCATION

LoneStar®, 9000i, ProStar®, TranStar®, PayStar®, WorkStar®, DuraStar®, and TerraStar™ Series: Located left door opening, rear post

#### COMPONENT IDENTIFICATION NUMBERS

Component Feature Codes appear on the vehicle line set ticket.

Component serial numbers appear on the components.

Feature Code:                      Serial Number:

#### FRONT AXLE

|  |  |
|--|--|
|  |  |
|--|--|

#### REAR AXLE

|  |  |
|--|--|
|  |  |
|--|--|

#### TRANSFER CASE

|  |  |
|--|--|
|  |  |
|--|--|

#### TRANSMISSION

|  |  |
|--|--|
|  |  |
|--|--|

#### ENGINE

|  |  |
|--|--|
|  |  |
|--|--|

#### ENGINE SERIAL NUMBER LOCATION

MAXXFORCE®: Stamped on pad – right side of the crankcase, below cylinder head

#### WORLD HEADQUARTERS

Navistar, Inc.  
4201 Winfield Road  
Warrenville, Illinois 60555 USA

#### INTERNATIONAL INTERNET SITE

[internationaltrucks.com](http://internationaltrucks.com)

#### SALES REGIONS

##### MIDWEST

Navistar, Inc.  
4201 Winfield Road  
PO Box 1488  
Warrenville, Illinois 60555  
630-753-5900

##### NORTHEAST

Navistar, Inc.  
Cherry Tree Corporate Center  
535 Route 38 East, Suite 300  
Cherry Hill, New Jersey 08002  
856-486-2300

##### SOUTHEAST

Navistar, Inc.  
2400 Commerce Avenue  
Building 1100, Suite 100  
Duluth, Georgia 30096  
678-584-2700

##### SOUTHWEST

Navistar, Inc.  
2595 Dallas Parkway, Suite 203  
Frisco, Texas 75034  
972-377-1200

##### WEST

Navistar, Inc.  
3017 Douglas Boulevard, Suite 300  
Roseville, California 95661  
916-774-7526

##### CANADA

Navistar Canada, Inc.  
5500 North Service Road – 4th Floor  
Box 5337  
Burlington, Ontario L7L 5H7  
905-332-3323

##### MEXICO

Navistar Mexico SA DE CV  
Ejército Nacional 904 – 8° Piso  
Col, Palmas Polanco 11510 Mexico D.F.  
525-262-6666

##### BRAZIL

International Caminhões do Brasil  
Av. Carlos Gomes, 466 conj 1002  
Bairro Auxiliadora – CEP 90480-000-  
Porto Alegre/RS  
55 51 4009-5800

#### CUSTOMER ASSISTANCE CENTER

1-800-448-7825 (1-800-44-TRUCK)

Navistar, International, the International Diamond logo, with and without endorsement, ProStar, and MaxxForce are registered trademarks of Navistar, Inc., or its subsidiaries, in the United States and other countries.

All other trademarks are the property of their respective owners.

## **Service Publications**

An Operator's Manual is shipped with this vehicle for customer use. Information on the purchase of other available service publications for this vehicle can be found on the [internationaltrucks.com](http://internationaltrucks.com) Web site, or by contacting your local International dealer.

It is the policy of Navistar, Inc. to improve its products whenever it is possible and practical to do so. We reserve the right to make changes or add improvements at any time without incurring any obligation to make such changes on products sold previously.

**Operator's Manual – ProStar®+ Series**

**Operator's Manual**

Form No. 3878859R2

© 2010 Navistar, Inc. All rights reserved.



**Section 1 – Foreword**

Preface.....1  
Cautions and Warnings.....1  
Assistance Guide.....1  
Component Code Numbers.....2  
    Line Set Ticket.....2  
Vehicle Storage Instructions.....2  
    Storage Duration - One Month or Less.....2  
    Storage Duration - Over One Month .....3  
    Storage Facilities .....4  
Exterior Noise Emissions.....4  
Tampering with Noise Control System Prohibited.....4  
Emission Control Systems.....5  
Maintenance Record – Noise Control.....5  
Reporting Safety Defects.....5  
    U.S. Registered Vehicles.....5  
    Canadian Registered Vehicles.....5  
Safety Recalls and Authorized Field Changes.....5  
Customer Security Guide for International Trucks.....6  
Optional Diamond Logic® Electronic Application Solutions....8

**Section 2 – Model Description**

Introduction.....9  
Available Models.....9  
Vehicle Identification.....12  
    Vehicle Identification Number (VIN).....12  
    Feature Codes.....12  
    Engine Serial Number.....13  
    Line Set Ticket.....13  
Exterior Components.....14  
Cab Entry and Exit.....18

Hood.....18  
    Raising the Hood.....18  
    Lowering the Hood.....19  
Tilt-Away Bumper.....19  
    Lowering the Tilt-Away Bumper.....20  
    Raising the Tilt-Away Bumper.....20  
Luggage Box Access.....21  
    Driver and Passenger Side.....21  
Chassis Skirts.....21  
    Removal.....21  
    Installation.....22  
Extended Chassis Skirts.....22

**Section 3 – Inspection Guide**

Introduction.....23  
    General Information.....23  
Tractor Inspection.....24  
    Preparation.....24  
    Exterior Lights Check .....24  
    Left Side Cab Area.....25  
    Left Engine Compartment.....26  
    Left Front of Tractor.....27  
    Front of Tractor.....29  
    Right Front of Tractor.....30  
    Right Engine Compartment.....32  
    Right Side of Cab.....33  
    Right Side Under Vehicle.....34  
    Right Rear of Tractor.....35  
    Rear of Tractor.....37  
    Left Rear of Tractor.....38  
    Fifth Wheel and Coupling Area.....40

## Table of Contents

---

|  |    |
|--|----|
| Cab Interior Inspection.....   | 41 |
| <b>Section 4 – Controls/Features</b>                                       |    |
| Introduction.....  | 43 |
| General Information.....   | 43 |
| Electrical.....  | 43 |
| Electrical System.....   | 43 |
| Dash Components.....   | 44 |
| Overhead Console.....  | 45 |
| Instrument Panel Gauge Cluster.....  | 46 |
| Warning Indicators.....  | 48 |
| Gauges.....  | 50 |
| Instrument Panel Gauge Cluster Alarms.....                                 | 52 |
| Direct Drive Warning Indicators.....                                       | 54 |
| Integral Digital Display.....  | 54 |
| General Text and Warning Messages.....                                     | 56 |
| Optional Instrument panel gauge cluster Compass Calibration Procedure..... | 57 |
| Compass Declination Zone Set Procedure.....                                | 57 |
| Compass Directional Calibration Procedure.....                             | 60 |
| Integral Digital Display Detailed Information.....                         | 62 |
| Switches.....  | 75 |
| Headlights.....  | 75 |
| Daytime Running Lights (DRL).....  | 75 |
| Lights On With Wipers.....   | 75 |
| Park Lights.....   | 75 |
| Panel Lighting.....  | 75 |
| Dome Lighting.....   | 76 |
| Courtesy Lights.....   | 76 |
| Steering Wheel Controls.....   | 77 |
| Cruise Control.....  | 78 |

|  |    |
|--|----|
| Steering Column and Switches.....                    | 78 |
| Center Dash Panel/Wing Panel.....                    | 81 |
| Gauges.....  | 82 |
| Switches.....  | 82 |
| Climate Control.....                                 | 86 |
| Air Conditioning.....                                | 88 |
| Dehumidification.....                                | 89 |
| Electronic Vehicle Monitoring.....                   | 89 |
| Base Display.....                                    | 89 |
| Premium Display.....                                 | 89 |
| SmartWave® Display.....                              | 89 |
| Door and Window Controls.....                        | 90 |
| Door Lock/Unlock.....                                | 90 |
| Cab Doors and Locks.....                             | 90 |
| Remote Keyless Entry Operation (Optional).....       | 90 |
| Lock/Unlock From Interior.....                       | 91 |
| Automatic Door Lock Function.....                    | 91 |
| Driver/Passenger Windows.....                        | 91 |
| Manual Operation.....                                | 91 |
| Power Operation.....                                 | 92 |
| Window Lockout Function.....                         | 92 |
| Mirror Controls.....                                 | 92 |
| Vent Window.....                                     | 92 |
| Eaton VORAD Collision Warning System (Optional)..... | 93 |
| System Description.....                              | 93 |
| Driver Reward.....                                   | 93 |

## Section 5 – Sleeper Features

|                          |    |
|--------------------------|----|
| Introduction.....        | 95 |
| General Information..... | 95 |
| Main Features.....       | 95 |

Lighting.....97  
    Dome Light.....97  
    Reading Lights.....97  
    Floor Lights.....97  
    Accent Lights.....97  
Sleeper Control Panel.....98  
    General Information.....98  
    Accent Light Dimmer Switch.....99  
    Accent Light Switch.....99  
    Sleeper Dome/Floor Light Switch.....99  
    Engine Control Switch.....99  
    Manual Climate Controls.....100  
    Electronic Climate Controller.....100  
    Power Receptacle.....101  
    Radio Remote Control.....101  
    Remote Power Inverter Panel.....101  
Windows.....102  
    General Information.....102  
Bunk Restraint System.....103  
    General Information.....103  
    Adjustable Belts.....103  
    Restraint Webbing System.....103  
Lower Bunk.....105  
    General Information.....105  
Upper Bunk.....106  
    General Information.....106  
    Entering The Upper Bunk.....107  
    Exiting The Upper Bunk.....108  
Cabinets/Storage.....109  
    General Information.....109  
Cabinets.....110  
    Refrigerator Cabinet.....110

Horizontal Refrigerator.....111  
Dresser Cabinet.....111  
Tower Wardrobe Cabinet.....112  
Rear Wardrobe Cabinet.....113  
Airline Cabinets.....114  
Convenience Features.....115  
    General Information.....115  
    Sleeper Curtain.....115  
    Television Mount.....115  
    Power Inverter.....115  
    Power Sockets.....115  
    Speakers.....115  
    Floor Covering.....115  
    Sleeper Fan.....115

**Section 6 – Operation**

Operation Safety.....117  
    General Information.....117  
    Cab Controls.....118  
Seat Belts.....118  
    General Information.....118  
    General Information.....119  
    Operation.....119  
    Care of Seat Belts.....120  
Seats.....121  
    General Information.....121  
Starting Procedures.....123  
    General Information.....123  
    Engine Starting.....123  
    After the Engine Starts.....124  
    Engine Shutdown.....124

## Table of Contents

---

|  |     |   |     |
|--|-----|---|-----|
| Emergency Starting.....  | 124 | Engine Oil.....                                     | 136 |
| Cold Weather.....  | 125 | Engine Performance Problems.....                    | 136 |
| General Information.....   | 125 | Fuel.....   | 137 |
| Cold Weather Starting.....   | 125 | Ultra Low Sulfur Diesel Fuel Requirements.....      | 137 |
| Cold Weather Operation.....  | 126 | Unacceptable Fuel Blends.....                       | 137 |
| Engine Idling.....   | 126 | Hazards of Diesel Fuel/Gasoline Blends.....         | 137 |
| Engine Idle Shutdown Timer (Optional).....   | 127 | Additional Unsafe Practices.....                    | 137 |
| Winter Front Usage.....  | 127 | Fuel and Lubricant Additives.....                   | 137 |
| Hot Weather Operation.....   | 127 | Fueling Procedures.....                             | 137 |
| Operating Instructions.....  | 128 | Fueling Precautions.....                            | 138 |
| General Information.....   | 128 | Reserve Fuel.....                                   | 138 |
| Steering.....  | 128 | Exhaust Diesel Particulate Filter Regeneration..... | 139 |
| Adjustable Steering Column.....  | 129 | Parked Regeneration Procedure.....                  | 141 |
| General Information.....   | 129 | Regeneration Inhibit Switch.....                    | 141 |
| Electrical.....  | 130 | Two-Position Regeneration Inhibit Switch.....       | 142 |
| Alternator.....  | 130 | Three-Position Regeneration Inhibit Switch.....     | 142 |
| Battery.....   | 130 | Transmission.....                                   | 142 |
| BATTERY ON Indicator.....  | 131 | Manual Transmissions.....                           | 142 |
| Circuit Breakers, Fuses and Fusible Links.....   | 131 | Engaging the Clutch.....                            | 143 |
| Electrical Load Control and Shedding (ELCS).....   | 132 | Hydraulic Clutch Actuation System.....              | 144 |
| Engine.....  | 132 | Double Clutch Procedures.....                       | 145 |
| Charge Air Cooler.....   | 132 | Clutch Precautions.....                             | 145 |
| Electronic Engine Controller.....  | 133 | Eaton AutoShift® Transmissions (Optional).....      | 146 |
| Engine Brake.....  | 133 | Eaton UltraShift® Transmissions (Optional).....     | 148 |
| MaxxForce® 11, 13 and 15 Engine Brake With<br>Eaton AutoShift®/UltraShift® Transmissions |     | Clutch Brake.....                                   | 148 |
| Special Driver Instructions.....   | 133 | Power Take-off Control.....                         | 148 |
| MaxxForce® Engine Features.....  | 134 | Rear Axles.....                                     | 148 |
| Certified Clean Idle.....  | 134 | Locking or Limited Slip Differentials.....          | 148 |
| Self Diagnostics.....  | 134 | Tandem Axle Power Divider Lock (PDL) Control.....   | 149 |
| Air Compressor Cycling.....  | 135 | Driver Controlled Differential Lock.....            | 150 |
| Cooling System.....  | 135 | Rear Suspension.....                                | 150 |
|  |     | Rear Air Ride Suspension.....                       | 150 |



|  |     |  |     |
|--|-----|--|-----|
| Rear Air Suspension Air Dump.....                        | 150 | Towing Vehicle With Front Wheels Suspended.....      | 164 |
| Air Suspension System Faults.....                        | 151 | Towing Vehicles With Driver Controlled Differential  |     |
| Brakes.....  | 151 | Lock.....  | 164 |
| General Information.....                                 | 151 | Removing Axle Shafts Before Towing.....              | 164 |
| Downhill Operation.....                                  | 152 | Installing Axle Shafts.....                          | 165 |
| Air Brakes.....  | 152 | Towing Vehicle With Rear Wheels Suspended.....       | 165 |
| General Information.....                                 | 152 | Tractor-Trailer Connections.....                     | 166 |
| Air Gauge, Low Air Pressure Beeper and Warning           |     | Connecting/Disconnecting a Trailer to a Vehicle with |     |
| Indicator.....   | 153 | Air Suspension.....                                  | 166 |
| Reservoir Moisture Draining.....                         | 153 | Fifth Wheel Operation.....                           | 166 |
| Brake Application.....                                   | 154 | Fifth Wheel Slide Switch (Optional).....             | 167 |
| Parking Brake.....                                       | 154 | Hook-Up.....   | 167 |
| Parking Brake Reset.....                                 | 155 | Un-Hook.....   | 168 |
| Parking Brake Alarm.....                                 | 155 | Fifth Wheel Jaw Unlock Control.....                  | 168 |
| Air Dryer.....   | 155 | Fifth Wheel Jaw Monitoring.....                      | 169 |
| Trailer Brake Hand Control.....                          | 155 |  |     |
| Trailer Air Supply and Parking Brake Modular Controls... | 156 |  |     |
| Parking Brake Indicator.....                             | 157 |  |     |
| Bobtail Proportioning System.....                        | 157 |  |     |
| Antilock Brake System (ABS).....                         | 158 |  |     |
| General Information.....                                 | 158 |  |     |
| ABS Operation.....                                       | 158 |  |     |
| ABS Self Check.....                                      | 159 |  |     |
| Antilock Driving Tips.....                               | 159 |  |     |
| Automatic Traction Control (ATC) System.....             | 159 |  |     |
| General Information.....                                 | 159 |  |     |
| ATC System Check.....                                    | 160 |  |     |
| ATC OFF ROAD or MUD/SNOW Switch.....                     | 160 |  |     |
| Stability Control Systems – Bendix® RSP/WABCO            |     |  |     |
| RSC/Bendix ESP.....                                      | 160 |  |     |
| Towing Instructions.....                                 | 162 |  |     |
| Tow Hooks.....   | 163 |  |     |

**Section 7 – Maintenance Instructions**

|  |     |
|--|-----|
| Introduction.....                        | 171 |
| Maintenance Guidelines.....              | 171 |
| Supporting Your Vehicle for Service..... | 173 |
| Chassis Lubrication.....                 | 173 |
| Air Conditioning Service Checks.....     | 174 |
| HVAC Filters.....                        | 174 |
| Side Access HVAC Filter.....             | 174 |
| Front Access HVAC Filter.....            | 175 |
| Recirculation Filters.....               | 175 |
| Sleeper HVAC Filter.....                 | 176 |
| Axles.....                               | 176 |
| Front Axle.....                          | 176 |
| Inspection and Lubrication.....          | 176 |
| Normal Maintenance.....                  | 177 |

## Table of Contents

---

|  |     |   |     |
|--|-----|---|-----|
| Alignment.....   | 177 | General Information.....  | 186 |
| Rear Axle .....  | 177 | Engine fluids and contaminated material.....                        | 187 |
| Inspection and Lubrication.....                        | 177 | Scheduled Maintenance .....   | 187 |
| Locking Differential.....                              | 178 | Air Induction System.....   | 187 |
| Brakes.....  | 178 | Air Restriction Gauge.....  | 188 |
| General Information.....                               | 178 | Air Cleaner Element Service.....                                    | 189 |
| Air Brakes.....  | 179 | Troubleshooting.....  | 191 |
| Inspection and Adjustment.....                         | 179 | Charge Air Cooler And Radiator Core Inspection<br>And Cleaning..... | 192 |
| Air Dryer.....   | 180 | Inspection and Cleaning.....  | 192 |
| General Information.....                               | 180 | Cooling System.....   | 192 |
| Desiccant Filter.....                                  | 181 | Coolant Level Check.....  | 192 |
| Purge Valve.....                                       | 181 | Filling Instructions.....   | 192 |
| Heater.....  | 181 | Coolant and Optional Coolant Filter.....                            | 194 |
| Air Reservoir/Tanks Moisture Draining.....             | 181 | Coolant Concentration Freeze Point.....                             | 194 |
| ABS Connections and Sensors.....                       | 182 | Antifreeze.....   | 194 |
| Cab.....   | 182 | Fan Clutch.....   | 194 |
| Care of Vehicle.....                                   | 182 | Fuel System.....  | 195 |
| Washing and Waxing.....                                | 182 | Fuel Tank Draining and Cleaning.....                                | 195 |
| Bright Metal Care.....                                 | 182 | Crankcase Ventilation Filter.....                                   | 195 |
| Upholstery Care.....                                   | 182 | Frame.....  | 195 |
| Exposed Rubber and Unpainted Plastic Parts.....        | 182 | Noise Emissions – Exterior.....                                     | 196 |
| Clutch.....  | 183 | Instructions for Proper Maintenance.....                            | 196 |
| Pedal Free Travel.....                                 | 183 | Air Intake System.....  | 196 |
| Hydraulic Clutch.....                                  | 183 | Body.....   | 196 |
| Electrical.....  | 184 | Cooling System.....   | 196 |
| Batteries .....  | 184 | Engine Noise Shields/Blankets.....                                  | 196 |
| Battery Cables.....                                    | 185 | Exhaust System.....   | 196 |
| Electrical Charging and Starting System Test.....      | 185 | Diesel Particulate Filter (DPF).....                                | 196 |
| Terminal Inspection-Cleaning-Corrosion Protection..... | 185 | Regeneration.....   | 196 |
| Accessory Feed Connections.....                        | 186 | Cleaning.....   | 197 |
| Fuses and Relays.....                                  | 186 | Drive Shafts.....   | 197 |
| Engine.....  | 186 |   |     |

|   |     |
|---|-----|
| Suspension (Air and Steel Springs).....                 | 197 |
| Front Suspension.....                                   | 197 |
| Rear Suspension.....                                    | 198 |
| Steering.....   | 198 |
| General Information.....                                | 198 |
| Tightening Steering Intermediate Shaft Joint Bolts..... | 198 |
| Lubrication Points.....                                 | 199 |
| Power Steering.....                                     | 199 |
| Tires.....  | 199 |
| Tire Warnings.....                                      | 199 |
| Tire Maintenance.....                                   | 201 |
| Checking Inflation.....                                 | 201 |
| Underinflation.....                                     | 201 |
| SmartWave® Tire Pressure Monitoring System (TPMS).....  | 202 |
| Inspection.....   | 202 |
| Loads.....  | 203 |
| Dual Tires Matching.....                                | 203 |
| Dual Tires Mixing.....                                  | 203 |
| Rotation.....   | 203 |
| Rotation Is Advisable.....                              | 203 |
| Tire Replacement.....                                   | 204 |
| Wheel and Tire Balancing.....                           | 204 |
| Wear.....   | 204 |
| Irregular Wear.....                                     | 205 |
| Use of Tire Chains.....                                 | 205 |
| Wheels.....   | 205 |
| Wheel and Wheel Nut Maintenance and Installation.....   | 205 |
| Wheel Nut Torque Maintenance.....                       | 206 |
| Hub-Piloted Wheel Installation Procedures.....          | 206 |
| Transmission.....                                       | 208 |

## Section 8 – Maintenance Intervals and Specifications

|  |     |
|--|-----|
| Lubrication and Maintenance Intervals.....         | 209 |
| Maintenance Intervals.....                         | 209 |
| Lubrication and Fluids Charts.....                 | 217 |
| Components Requiring Lubrication.....              | 218 |
| Components Requiring Fluid Check and Fill.....     | 219 |
| Unit Refill Capacities.....                        | 220 |
| Cooling System Refill Capacities.....              | 220 |
| Crankcase and Oil Filters.....                     | 220 |
| Hydraulic Clutch System.....                       | 220 |
| Power Steering Systems.....                        | 220 |
| Transmission.....                                  | 221 |
| Rear Axle Unit Refill Capacities.....              | 222 |
| Lubricant and Sealer Specifications.....           | 223 |
| Torque Specifications.....                         | 227 |
| U-Bolt Nut Torque Chart.....                       | 227 |
| Disc Wheel Nut Torque Chart.....                   | 228 |
| Fuse Charts.....                                   | 228 |
| Typical Interior Fuse Panel Layout.....            | 229 |
| Typical Luggage Compartment Fuse Panel Layout..... | 230 |
| ProStar®+ Series Light Information.....            | 231 |
| Filter List.....                                   | 232 |

## Section 9 – Customer Assistance

|   |     |
|---|-----|
| Service Information.....                  | 233 |
| International Truck Warranty Program..... | 233 |

**Table of Contents**

---

**Section 10 – Index**

Index.....235

## SECTION 1 — FOREWORD

### Preface

Your vehicle has been engineered and manufactured so that it can provide economical and trouble-free service. However, it is the owner's responsibility to see that the vehicle receives proper care and maintenance.

Making modifications to various parts, components, and systems of your vehicle, such as brake, suspension, and steering systems, can adversely affect the quality and reliability of your vehicle. Such modifications must be avoided.

### Cautions and Warnings

Throughout this manual, you will find Cautions and Warnings:



**Warnings advise you of hazards, the consequences, and what to do to prevent them, not only to prevent damage to your vehicle or property, but to help prevent situations and occurrences, which could result in personal injury or death.**



**Cautions will advise you of the proper care to be taken to prevent damage to your vehicle or property.**

Study this manual carefully. Do not operate your vehicle until you are completely familiar with the contents of this manual. Always retain this manual in your vehicle for reference. If you sell the vehicle, make sure the manual goes with it.

### Assistance Guide

When parts are required, always provide the unit code number, vehicle model, and vehicle serial number. Request the salesperson to assist you in obtaining this information upon delivery.

For information not given in this manual, or if you require services of trained service personnel, we urge you to contact a nearby International dealer or phone 1-800-44-TRUCK (87825) for assistance.

Every customer is entitled to the best service, both from the product itself and from the firm that sells and services that product.

If, for any reason, you do not feel you are receiving these services in connection with the operation of your vehicle or the sales transaction, you should return to your selling dealer, so that these matters can be corrected to your satisfaction. If the matter is not resolved at that time, it is suggested that the following steps be taken:

#### **Contact a Member of Management at the Dealer.**

Discuss the details of the difficulty. In most instances, any problem can be resolved to your satisfaction by the owner or manager in charge.

### Contact Closest Navistar, Inc. Regional Sales Office.

Addresses of Regional Sales Offices are found in the front of this manual. Should you desire to contact any of these offices, it is important to include the following information in your communication:

- Name under which new vehicle was purchased, address, and telephone number of purchaser
- Vehicle model, year, vehicle identification number, component code, and serial number
- Vehicle delivery date and present mileage
- Location where purchased
- Details of the problem

### Component Code Numbers

Code numbers are the basis for identifying the components used on International trucks. They are used by sales personnel to order the truck, by manufacturing to build that truck, and by parts personnel to service the truck. Many items in this manual are identified by codes.

Code numbers are a combination of numbers and/or letters. These codes are listed on the Line Set Ticket, which is sometimes known as the vehicle specification card or code sheet.

### Line Set Ticket

Each vehicle is provided with a Line Set Ticket (code sheet), which lists identification code numbers of component units used to build the vehicle.

One copy of the Line Set Ticket is included in the literature provided with the vehicle. When replacement parts are required, take this copy with you to positively identify vehicle components to be sure of getting the correct parts.

### Be Sure To Return Line Set Ticket To Vehicle After Obtaining Parts.

### Vehicle Storage Instructions

When a vehicle is not used for an extended period of time, precautions must be taken to prevent deterioration of vehicle components. Vehicles that are out of service for extended periods of time can experience corrosion and other undesirable effects. Drive vehicle monthly to exercise the brakes, driveline and steering. Run the vehicle long enough for the engine to reach operating temperature.

**NOTE:** Losses occurring to a unit while it is in storage will not be considered for warranty reimbursement.

### Storage Duration - One Month or Less

1. Wash vehicles as necessary. Always wash vehicles that have been exposed to road salt.

**NOTE:** Washing Instructions - Wash the vehicle with warm water and mild soap, then wipe wet surfaces with a chamois or soft cloth. DO NOT use hot water or strong soaps or detergents. DO NOT wash the vehicle in direct sun, or when the sheet metal is hot to the touch. This will streak the finish. DO NOT wipe dirt off dry surfaces, as this will scratch the finish.

**NOTE:** When vehicles are stored outside, particularly in coastal areas (salt water and high humidity atmosphere) or other areas of corrosive environment, paint and bright metal may require frequent washing and waxing to prevent deterioration. Determining washing frequency is the customers responsibility.

**NOTE:** For vehicles exposed to ultraviolet rays of the sun, apply a coating of Bon-Ami® soap, or similar product, to the inside surfaces of the windshield and windows, to shade the interior and prevent fading of the interior trim.

2. Inspect painted surfaces; touch up all exposed primed or raw metal areas to prevent rust.
3. a thick coat of wax to prevent discoloration from the elements; wax all chrome and stainless steel metal parts.
4. Check the radiator coolant for proper level and adequate freeze protection [-20°F (-29°C) is standard for medium duty models and bus chassis, -40°F (-40°C) is standard for heavy duty models].
5. Cover open ends of vertical exhaust stack(s).
6. Drain air brake reservoirs and close the drain cocks.
7. Lubricate all exposed transmission, auxiliary transmission and PTO shift rails.

8. Check state of charge eye in batteries and re-charge if open circuit voltage is below 12.6 volts. Disconnect battery ground cables to prevent accidental starting, or parasitic electrical loads from discharging the battery.

### **Storage Duration - Over One Month**

Units in storage longer than one month should be driven until the engine reaches operating temperature:

1. Insure all tires are inflated properly, remove vertical exhaust stack covers and reconnect batteries.
2. Check all vehicle fluid levels and fill as required.
3. Start and run the vehicle at fast idle, until it reaches operating temperature. To remove surface charge from the battery, built up from previous start-ups and short idle periods, operate the heater and/or air conditioner, headlights and other accessories for several minutes.
4. Turn off heater and/or air conditioner and any other accessories; shut off the headlights. Park the vehicle and shut off the engine.
5. Perform the procedure for **Storage Duration - One Month or Less**, if returning the vehicle to storage.

**NOTE:** After every 30 additional days of storage, perform Items 1 through 5.

### Storage Facilities

- A. Whenever possible, store vehicles indoors, protected from sunlight, in a dry, well ventilated area. If indoor storage is not available, select storage lots to eliminate conditions that cause deterioration.
- B. Park away from transformers and/or electrical motors, because when the protective wax in tire compound cracks, ozone in the air attacks the exposed areas.
- C. Park away from trees, high weeds and/or grass to prevent damage from tree or weed sap, and to minimize bird and insect stains.
- D. Park away from railroad tracks, paint shops, smoky industrial areas, and locations of possible road splash contact.
- E. If a vehicle is parked on an incline, block the wheels.

### Exterior Noise Emissions

Many operators and owners of the type of vehicles described herein are subject to *Federal Motor Carrier Safety Regulations and Noise Emission Requirements*. All owners and operators are urged to obtain a copy and comply with these regulations. Copies of these regulations can be purchased from:

Superintendent of Documents  
U.S. Government Printing Office  
Washington, D.C. 20402

Navistar, Inc. warrants to the first person who purchases this vehicle for purposes other than resale and to each subsequent

purchaser that this vehicle, as manufactured by Navistar, Inc., was designed, built, and equipped to conform at the time it left Navistar, Inc. control with all applicable U.S. Environmental Protection Agency Noise Control Regulations.

This warranty covers this vehicle as designed, built, and equipped by Navistar, Inc. and is not limited to any particular part, component, or system of the vehicle manufactured by Navistar, Inc. Defects in design, assembly, or in any part, component, or system of the vehicle as manufactured by Navistar, Inc., which at the time it left Navistar, Inc. control, that cause noise emissions to exceed Federal standards are covered by this warranty for the life of the vehicle.

### Tampering with Noise Control System Prohibited

Federal law prohibits the following acts or the causing thereof: (1) The removal or rendering inoperative by any person, other than for purposes of maintenance, repair, or replacement, of any device or element of design incorporated into any new vehicle for the purpose of noise control prior to its sale or delivery to the ultimate purchaser or while it is in use, or (2) The use of the vehicle after such device or element of design has been removed or rendered inoperative by any person. Among those acts presumed to constitute tampering are the acts listed as follows: A. Air Intake System: Removal of air cleaner, intake silencer, or piping. B. Acoustical Shielding (Body): Removal of wheel well splash shields, cab shields, or acoustical (underhood) insulation. C. Cooling System: 1. Removal or rendering inoperative the fan clutch. 2. Removal of fan shrouds. D. Engine and Driveline System: 1. Removal or rendering engine speed governor inoperative so as to allow engine speed to exceed manufacturer specifications. 2. Removal of engine



block shield, oil sump shield, or transmission enclosures. E. Exhaust System: Removal or rendering inoperative exhaust system components, including muffler, resonator, or tailpipe.

Use the following Maintenance Record – Noise Control form to log Noise Emission Maintenance of, at a minimum, the above systems.

### Emission Control Systems

**NOTE:** Federal and California emission system warranties are found in your Engine Operation and Maintenance Manual.

### Maintenance Record – Noise Control

|                       |                   |                                |      |
|-----------------------|-------------------|--------------------------------|------|
| Chassis Model:        |                   | Vehicle Identification Number: |      |
| Maintenance Performed | Maintainer (Name) | Location                       | Date |
|                       |                   |                                |      |
|                       |                   |                                |      |
|                       |                   |                                |      |
|                       |                   |                                |      |

### Reporting Safety Defects

#### U.S. Registered Vehicles

If you believe that your vehicle has a defect, which could cause a crash or could cause injury or death, you should immediately inform the National Highway Traffic Safety Administration

(NHTSA) in addition to notifying Navistar, Inc. To notify Navistar, Inc., see regional numbers listed in the front of the manual.

If NHTSA receives similar complaints, it may open an investigation and, if it finds that a safety defect exists in a group of vehicles, it may order a recall and remedy campaign. However, NHTSA cannot become involved in individual problems between you, your dealer, or Navistar, Inc.

To contact NHTSA, you may either call the Auto Safety Hotline toll-free at 1-800-424-9393 (or 202-366-0123 in Washington, D.C. area) or write to: NHTSA, U.S. Department of Transportation, Washington, D.C. 20590. You can also obtain other information about motor vehicle safety from the hotline.

#### Canadian Registered Vehicles

If you believe that your vehicle has a defect, which could cause a crash or could cause injury or death, you should immediately contact Navistar, Inc. Canada and then Transport Canada.

To contact Navistar, Inc. Canada, you may either call the Regional Service Manager (Canadian Sales Region) 905-332-2357 or write to: Navistar, Inc. Canada, 5500 North Service Road, Box 5337, Burlington, Ontario L7L 5H7.

To contact Transport Canada, Defect Investigations and Recalls, you may call 1-800-333-0510 or write to: Transport Canada, ASFAD, Place de Ville Tower C, 330 Sparks Street, Ottawa, Ontario K1A 0N5.

### Safety Recalls and Authorized Field Changes

Safety Recalls and Authorized Field Changes are two campaigns that are used to notify owners of modifications that may involve

their vehicle. If you receive such notification, **PLEASE FOLLOW ALL INSTRUCTIONS PROVIDED IN THE CUSTOMER LETTER**. If your vehicle is part of a Safety Recall campaign, the recall service procedure must be completed to ensure safe operation of your vehicle. As a vehicle owner, you must provide International dealers with address corrections and changes to ensure that you receive all notifications. Please verify that your local dealer has your correct address. Dealers will also have a record of any outstanding campaigns that affect your vehicle.

### Customer Security Guide for International Trucks

This guide has been prepared to help you protect your vehicle investment from theft. We realize the financial commitment you have made is significant, and that you depend on that vehicle to generate profits and a livelihood. Vehicle theft can be more than an economic crime. Protecting your vehicle from theft or hijacking can be crucial to the safety and security of the country and economy. While no system or device is 100 percent effective, our intention is to provide some tips that you or your drivers can use to reduce the risk of theft.

If you suspect vehicle theft activity, take a minute to tell the National Insurance Crime Bureau (NICB) at 1-800-TEL-NICB. You can make the free call anonymously, and you might be eligible for a reward. To learn more about vehicle theft and how you can protect yourself, visit the NICB's Web site, [www.nicb.org](http://www.nicb.org).

### Add Layers of Protection

Four layers of protection are recommended for your vehicle - the more layers of protection on your vehicle, the more difficult it is to steal.

#### Layer 1: Common Sense

- Lock your doors.
- Remove your keys from the ignition.
- Close your windows completely.
- Park in well-lit areas.
- Drop a business card with your name on it between the glass and doorframe. This can aid in identifying the truck when it's recovered.
- Keep a copy of the lineset ticket in a location other than your truck for reporting purposes and a copy of the VIN in your wallet.
- Photograph the interior and exterior of your truck from various angles and keep these photographs in a safe nontruck location or send them to your insurance agent.
- Report a theft as soon as it's discovered to the local police and to your insurance company.
- Post a *driver has no cash* sign on your door to discourage a robbery.

- Permanently mount your CB radio or remove it when you will be away from your truck.
- Do not discuss where your vehicle is located when you are not on the road.
- Do not share information about your specific destination or the load you are hauling.
- Be conscious of other vehicles that may be following you over long distances - call the police.
- Be suspicious of motorists that are signaling you to stop or pull over. Call the police, report the incident, and let the police respond.

**Layer 2: Visible or Audible Device**

- Audible alarm system
- Steering wheel locks
- Steering column collars
- Theft deterrent decals
- Wheel locks
- Window etching
- Mechanical or electronic steering locks that restrict the steering shaft U-joint are easy to use and provide a very high level of affordable theft protection.

**Layer 3: Vehicle Immobilizer**

- A. Fuse cutoffs
- B. Kill switches
- C. Starter, ignition, and fuel disablers
- D. Fuel cutoff switch

**Layer 4: Tracking System**

The final layer is a tracking system that emits a signal to the police or a monitoring service when the vehicle is reported stolen. If your vehicle has a tracking system and is stolen, it can oftentimes be recovered faster and with less damage.

---

**VIN:**

---

**Model/Year:**

---

**Engine Serial Number:**

---

**License Number:**

---

**Insurance Company:**

---

**Policy Number:**

---

**Phone Number:**

---

**Other:**

---

### Optional Diamond Logic® Electronic Application Solutions



**This vehicle may be equipped from the factory with electrical switches intended to operate equipment that was installed by a truck equipment manufacturer (TEM). Instructions, Cautions, and Warnings for this additional equipment will NOT be found in this manual. Read and understand the appropriate manual for the specific equipment in question before operating. Failure to observe this warning may cause property damage, personal injury, or death.**

**NOTE:** This vehicle may be equipped with electronic application-specific options not described in this Operator's Manual. Many of these features are supplied with rocker switches that have custom labels applied. The presence of these options as factory-installed can be verified from the Line Set Ticket included with the vehicle. A truck equipment manufacturer (TEM), however, may have installed some of these options after production. In that case, they will not appear on the Line Set Ticket. If installed by a TEM, you should receive an operating guide and/or training for the specific functions provided. Familiarize yourself with all of the switches that control chassis, engine, and body equipment and seek adequate training on the function of all features before operating this vehicle.

## SECTION 2 — MODEL DESCRIPTION

### Introduction

The International® ProStar®+ Series Truck is available in two models, the International® ProStar®+ Series, International® ProStar®+ Eagle Series.

This operator's manual covers all versions. Illustrations in this manual are used for reference only, and may differ slightly from the actual vehicle. However, key components addressed in the manual are represented as accurately as possible. Models covered are shown on the following pages.

### Available Models

#### 4 x 2 Day Cab



#### 4 x 2 Day Cab with Full Aero Package

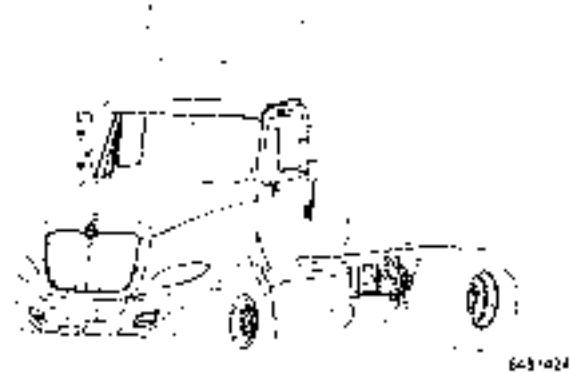

#### 6 x 4 Day Cab

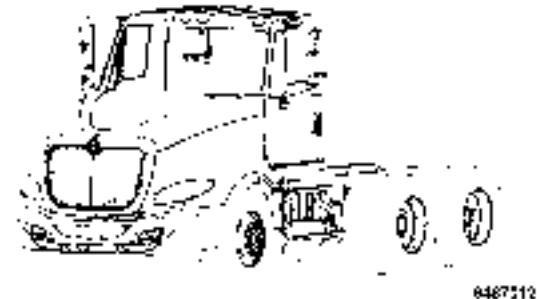

**Model Description**

---

**6 x 4 Day Cab with Full Aero Package**



**4 x 2 Short Sleeper (56-Inch) with Full Aero Package**



3487429

**4 x 2 Short Sleeper (56-Inch)**

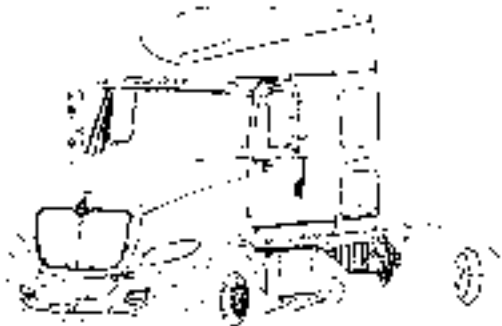

**6 x 4 Short Sleeper (56-Inch)**



6 x 4 Short Sleeper (56-Inch) with Full Aero Package

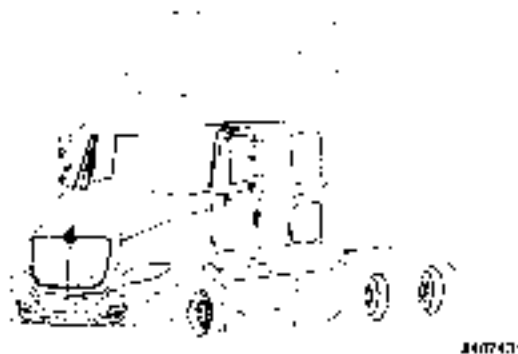

4 x 2 Long Sleeper (73-Inch) with Full Aero Package

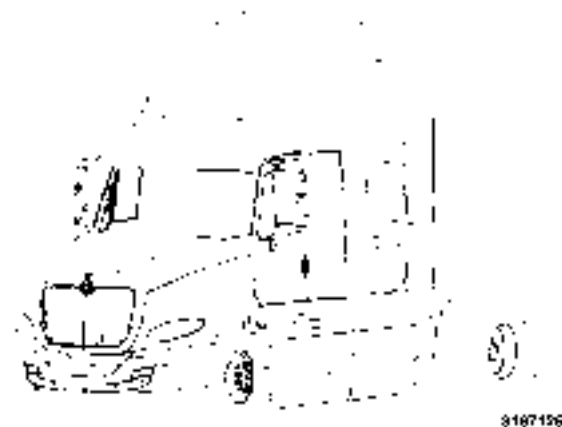

4 x 2 Long Sleeper (73-Inch)

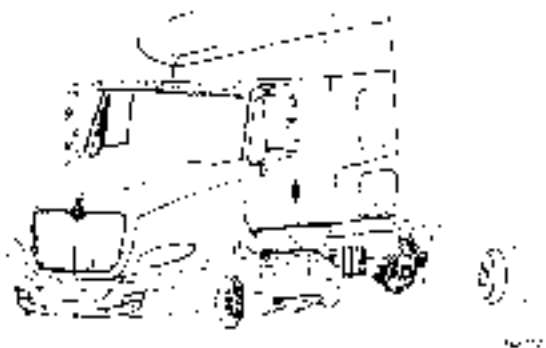

6 x 4 Long Sleeper (73-Inch)

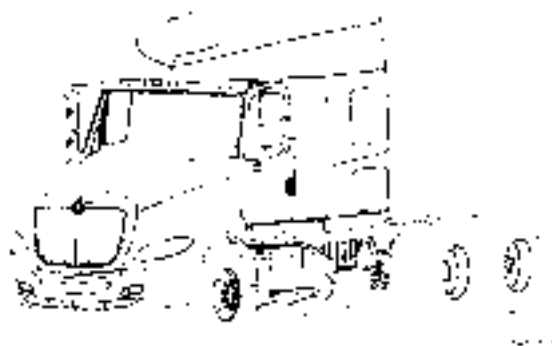





### Engine Serial Number

The engine dataplate provides the engine serial number as well as other engine information. For the location of this plate and more information about engine components and engine identification, refer to the Engine Operation and Maintenance Manual.

### Line Set Ticket

**NOTE:** Be sure to return Line Set Ticket to vehicle after obtaining parts.

Each vehicle is provided with a Line Set Ticket (code sheet) which lists identification code numbers of component units used to build the vehicle.

One copy of the line set ticket is included in the literature provided with the vehicle. When replacement parts are required, take this copy with you to positively identify vehicle components to be sure of getting the correct parts.

**Model Description**

---

**Exterior Components**

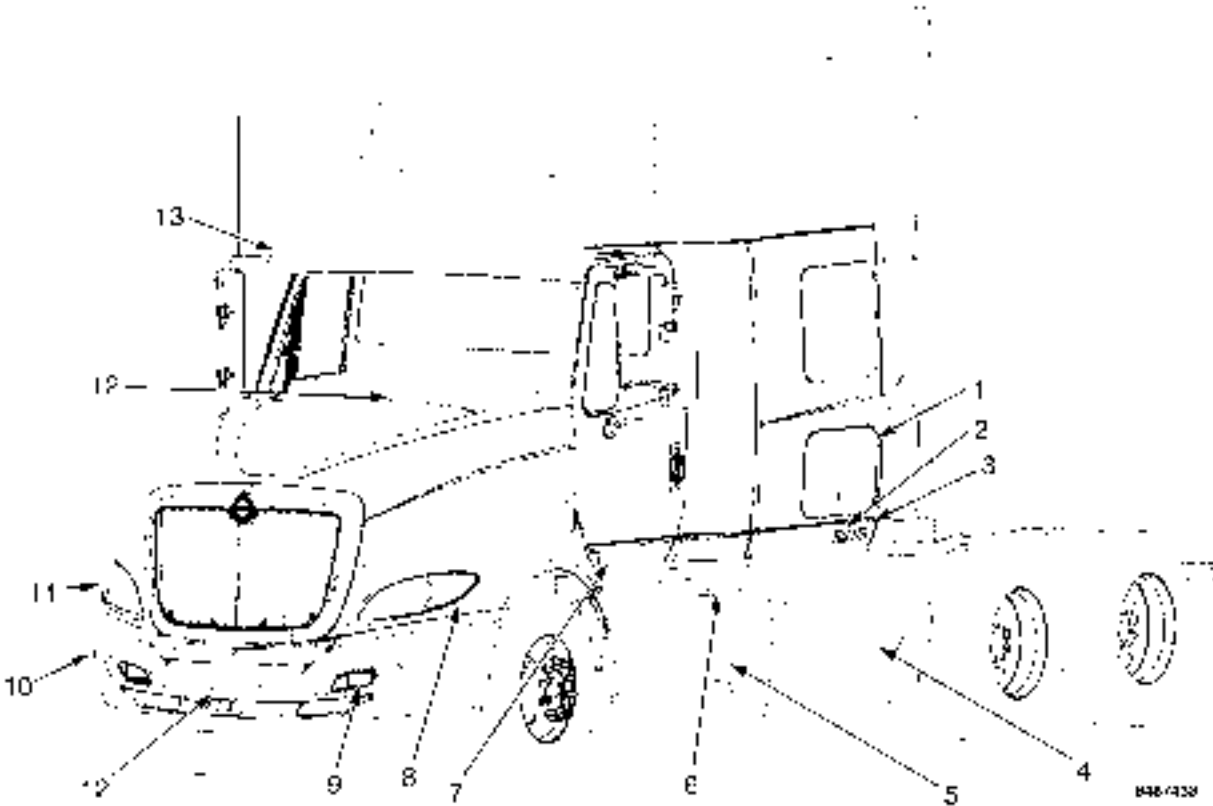

1. Luggage Door
2. External Hook-Ups for Telephone and TV
3. External Electrical Hook-Up (Shore Power)
4. Removable Skirt Option (Battery Access)
5. Chassis Skirt (Aero)
6. Fuel Cap
7. External Hook-Up for Block Heater
8. Side Marker/Turn Light
9. Fog Light
10. Tilt-Away Bumper
11. Headlight
12. VORAD (optional)
13. Sunshade

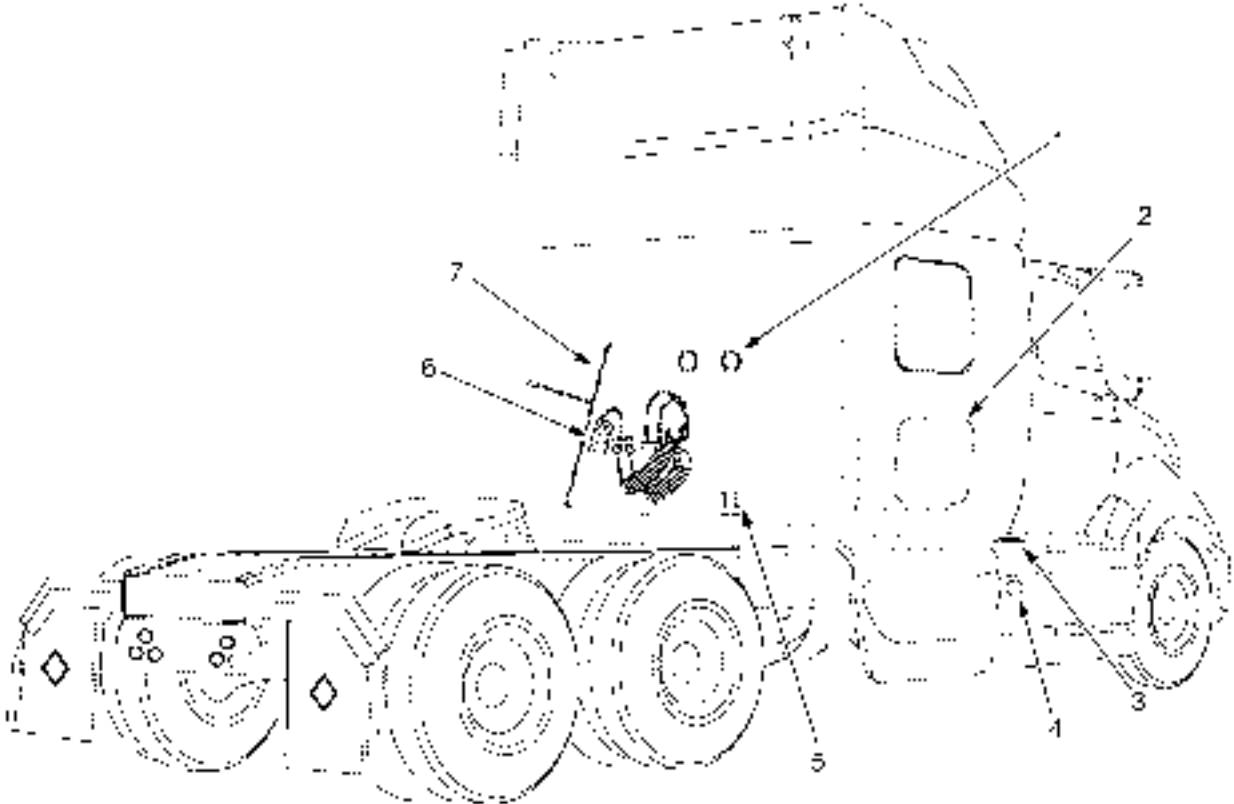

0487C10

1. Work Lights
2. Luggage Door
3. Fuel Cap
4. VORAD (optional)
5. In-Transit Heat (optional)
6. Gladhand Storage Bracket
7. Grab Handle

### Cab Entry and Exit



Do not step or climb upon any vehicle surface unless it is slip-resistant and a handhold is provided. Failure to follow this warning could cause you to slip or fall and could result in personal injury or death.



A three-point stance should be used (three out of four extremities should be in contact with the vehicle climbing system) at all times. Face inward towards the cab when entering and exiting. Always keep steps and handholds in continuous good repair. Make sure all attaching bolts and hardware are tight, thus eliminating any movement of steps and handholds. Keep steps, grab handles and shoes free of grease, mud, dirt, fuel, ice and snow. Use extra care during inclement weather. Failure to follow this warning could cause you to slip or fall and could result in personal injury or death.

### Hood

#### Raising the Hood

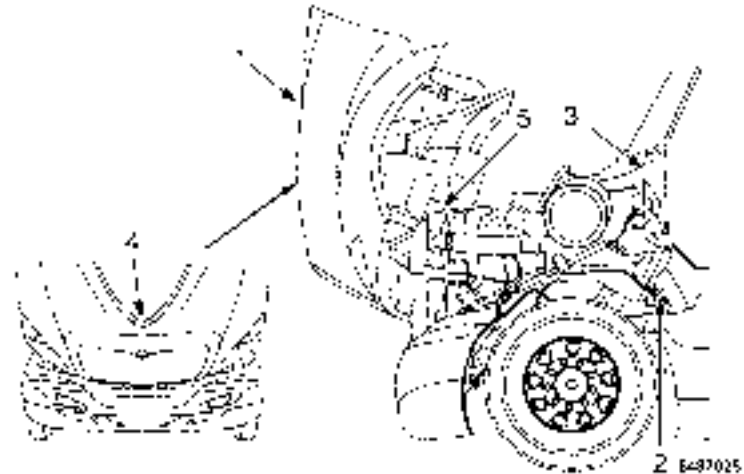

1. Hood
2. Hood Latch
3. Cowl
4. Hood Handle
5. Hood Restraining Shock



**To prevent personal injury or death, never put any part of your body beneath a raised hood unless the hood is all the way forward in its range of motion and is fully settled in the over center position.**

### CAUTION

**To prevent damage to the windshield wipers, return them to their normal position before opening or closing hood.**

### CAUTION

**Follow this procedure to prevent damage to the hood and/or painted surfaces.**

**NOTE:** To avoid pinching, do not lift or lower the hood from the side.

1. Before opening the hood make sure that there is enough room in front of the vehicle for the hood to open completely without pinning or pinching yourself between the hood and any other structures.
2. Release the latches on both sides of the cowl.
3. With both feet firmly on the ground, grasp the hood handle and pull the hood forward over center and allow it to settle into the raised position.
4. Make certain that the hood restraining shock is fully extended before releasing hood.

### Lowering the Hood

1. Make sure that the hood has no tools, parts, or people in its path of motion.
2. Place both hands on the top edge of the grille and push the hood backward over center and allow it to settle into lowered position.
3. Engage hood latches at both sides of cowl.

### Tilt-Away Bumper

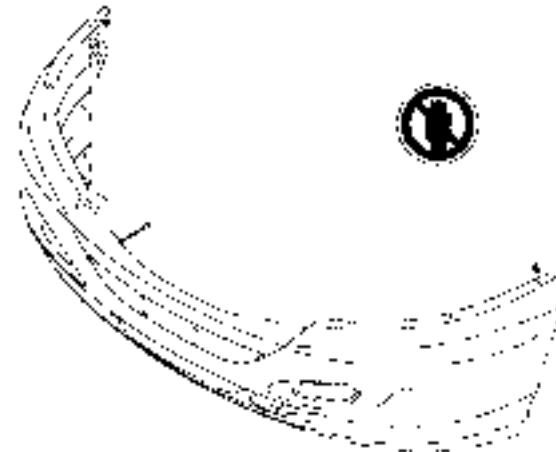

1407225

To avoid injury, a decal is attached to the top on each side of the bumper to identify the location not to place hands when raising and lowering the tilt-away bumper.

## Model Description

---

### Lowering the Tilt-Away Bumper

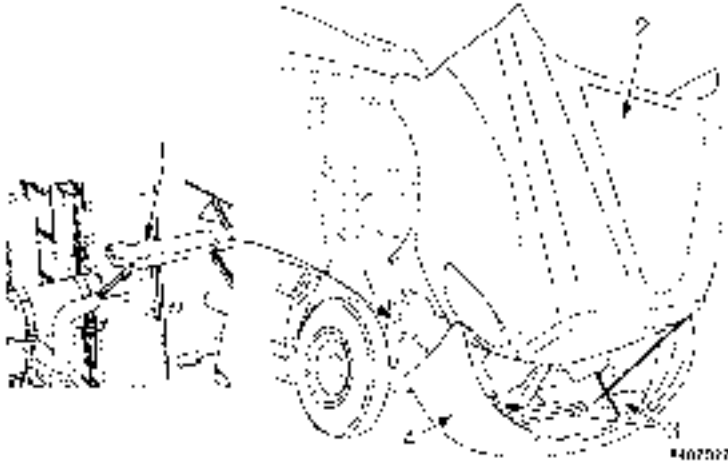

1. Bumper Support Latch
2. Hood
3. Support Cables
4. Tilt-Away Bumper

1. Raise the hood to the fully upright position.
2. While standing on the driver-side of the Tilt-Away bumper, support the bumper with the left hand and release the bumper support latch with the right hand.
3. Walk around to the passenger-side of the Tilt-Away bumper.
4. Support the Tilt-Away bumper with the right hand and release the bumper support latch with the left hand.
5. Grasp and slowly lower the Tilt-Away bumper until it is supported by the support cables.

### Raising the Tilt-Away Bumper

1. While standing on the passenger-side of the Tilt-Away bumper, lift the bumper with the right hand and secure the bumper using the support latch with the left hand.
2. Walk to the driver-side of the Tilt-Away bumper.
3. Secure the Tilt-Away bumper using the support latch with the right hand.
4. Lower and latch the hood.



## Luggage Box Access

### Driver and Passenger Side

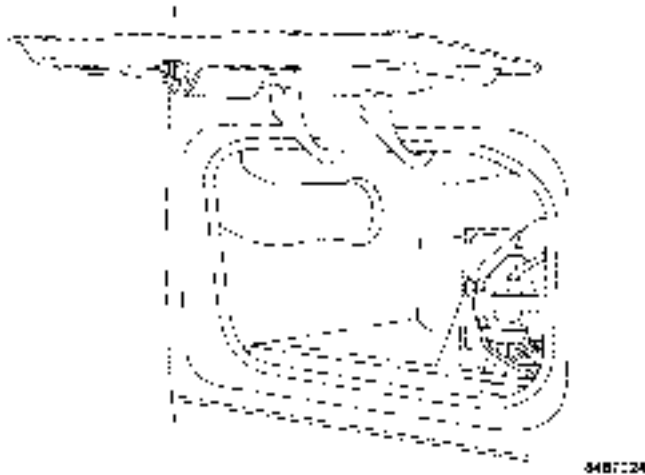

**NOTE:** Driver and passenger luggage boxes open in the same manner.

**NOTE:** Luggage box doors automatically lock when closed. Make sure you do not accidentally place and lock keys in the luggage box.

Open the luggage box door using the ignition/door key. The door will remain in a fully-opened position. To close the door, firmly push the door down and to the locked position. The door will automatically lock when shut.

## Chassis Skirts

The optional chassis skirts on the International® ProStar®+ Series trucks are available to provide improved aerodynamics. The rear driver side chassis skirt on sleeper models can be conveniently removed without tools to gain access to the battery box.

### Removal

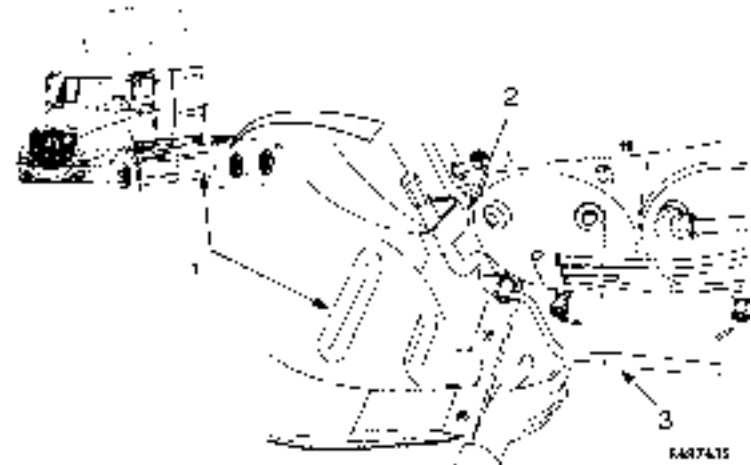

1. Chassis Skirt
2. Keeper Bracket
3. Locking Handle in Unlock Position

## Model Description

---

1. Locate the locking handle at the rear inside of the chassis skirt.
2. Release the locking handle from the keeper bracket.
3. Rotate the locking handle downward 90° to release the chassis skirt.



4. Grasp both ends of the chassis skirt and slide the chassis skirt upward, under the cab.
5. Allow the bottom of the chassis skirt to come outward and remove the chassis skirt from the vehicle.

## Installation

**NOTE:** There are two hooks on the back side of the chassis skirt that must be fully engaged on the mounting bar to be secured properly.

1. Grasp both ends of the chassis skirt, hold the bottom of the chassis skirt away from the vehicle, and slide the chassis skirt under the edge of the cab.
2. Lower the bottom of the chassis skirt onto the mounting bar and align the chassis skirt on the front chassis skirt and engage the two hooks.
3. Rotate the locking handle 90° upward to lock the chassis skirt in position.
4. Secure the locking handle in the keeper bracket.

**NOTE:** If vehicle is ordered with the optional No Idle Solution, the rear passenger side chassis skirt that covers additional batteries will remove and install the same as the rear driver side chassis skirt.

## Extended Chassis Skirts

Optional extended chassis skirts are available for the ProStar®+ Series trucks with sleeper and full aero package. While the passenger's side extended chassis skirt is stationary, the driver's side opens to allow access to the deck ladder. To open, pull out on the upper right hand corner of the extended chassis skirt and open to its full extension. To close, grab the upper right hand corner of the extended chassis skirt and guide it to its fully closed position.

## SECTION 3 — INSPECTION GUIDE

### Introduction

#### General Information



To prevent property damage, personal injury, or death when servicing the vehicle, park on a flat level service, set the parking brakes, turn the engine off, and chock the wheels.



Exercise care when working on vehicles with running engines that are equipped with an automatic fan clutch. The fan engages when engine coolant reaches a predetermined temperature or the refrigerant pressure (if equipped with air conditioning) reaches a predetermined setting. The fan will start with no advance warning. Failure to observe these precautions could result in vehicle damage, personal injury, or death.



If vehicle is equipped with an automatic transmission, have a qualified technician regularly check operation of transmission neutral start switch. If unit starts in gear, the vehicle may inadvertently move, which could result in property damage, personal injury, or death.

To be sure your vehicle is ready to operate, conduct a pre-trip inspection at the beginning of each work period. This section gives the operator suggested guidelines to be used in performing tractor and trailer pre-trip inspections. Safety is the most important and obvious reason for doing a pre-trip inspection. Depending on the optional features of the vehicle being used and any possible aftermarket items installed on the vehicle, these guidelines should be modified to include other necessary inspection points. Follow the steps in this section and check them off to assure a proper vehicle inspection procedure. The pages in this section may be reproduced locally and used on a regular basis.

If any component or system does not pass this inspection, it must be corrected before operating the vehicle. Take your time going through the pre-trip inspection. Remember that a careful pre-trip inspection saves time by eliminating unscheduled stops to correct a faulty item.

Illustrations in this section identifies key locations of inspection items. The illustrations herein are typical and may not represent all engine applications.

## Tractor Inspection

### Preparation

**NOTE:** Perform the following procedures prior to conducting the pre-trip inspection.

- Apply parking brakes.
- Turn on parking lights and hazard lights.
- Unhook the hood latches, raise the hood, unlatch and lower the tilt-away bumper.
- Check under the vehicle for oil, fuel, coolant leaks or other signs of damage.
- Use pull cables or open drain cocks to allow air tanks to expel any existing water. Release pull cables or close drain cocks.
- Chock wheels on tractor and trailer, if attached.
- Start the engine and allow the air pressure to build up to normal operating pressure of 115 to 130 psi (793 to 896 kPa). Stop engine.

### Exterior Lights Check

Perform an automatic check of all exterior lights by doing the following steps:

1. Place the ignition key in the ON or ACC position, place the transmission in neutral, and apply the parking brake.
2. Pressing the WORK LIGHT switch for approximately two seconds before releasing will activate this feature.
3. The exterior light check will now cycle all vehicle lights except the back-up light(s). The test flashes the exterior lights on and off in three, two second cycles. The first two second period illuminates park lights (clearance, identification, side marker and license plate lights), turn signal lights, low beam headlights, fog lights. The second two second period illuminates park lights (clearance, identification, side marker and license plate lights), high beam headlights, brake lights, work lights. The third two second period turns off all lights. This cycle repeats until deactivated by the operator.
4. Walk around vehicle and inspect illumination of lights.
5. To cancel this feature, do one of the following: either press the brake pedal, manually turn on any external light, turn the key to OFF, or release the parking brake. The feature will automatically cancel approximately 10 minutes after activation if not deactivated by the operator.
6. Checking the backup lights requires two people and the engine running. Depress the clutch (if applicable) and select reverse while the second person observes backup light operation.

## Left Side Cab Area

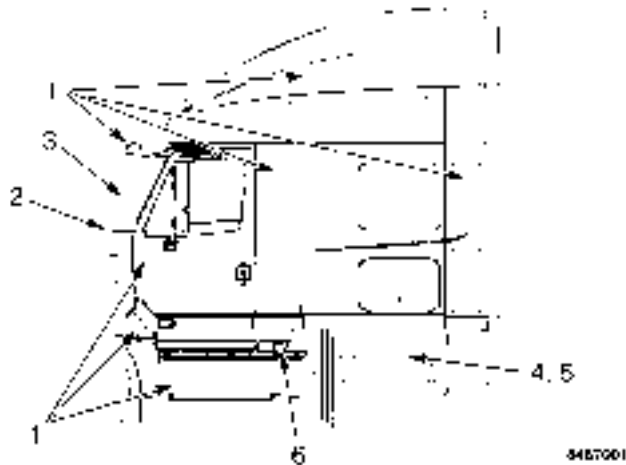

**NOTE:** If the vehicle is equipped with side skirts, it will be necessary to remove the left rear skirt to gain access to the battery box.

## Inspection Items

1. Cab Structure: Check body panels such as doors, fairings, air shield, sunshade, and cab extenders for signs of breaks or damage. Check condition of cab mounting brackets and tilt hood latches.
2. Wipers: Check windshield wiper arms for proper spring tension and wiper blades for damage.
3. Windshield: Check for damage to windshield and clean if dirty.
4. Battery Box: Inspect for damage and secure mounting of battery box. Remove battery box cover.
5. Batteries and Cables: Check that batteries are secured and cases are not broken or leaking. Ensure cables are free from damage. Tops of batteries and terminals must be clean and free from foreign material. Replace battery box cover.
6. Fuel Tank(s): Check to see that the fuel tank(s) and cap(s) are secured and make sure there is no damage or leaks at the tank(s) or fuel lines.

### Left Engine Compartment

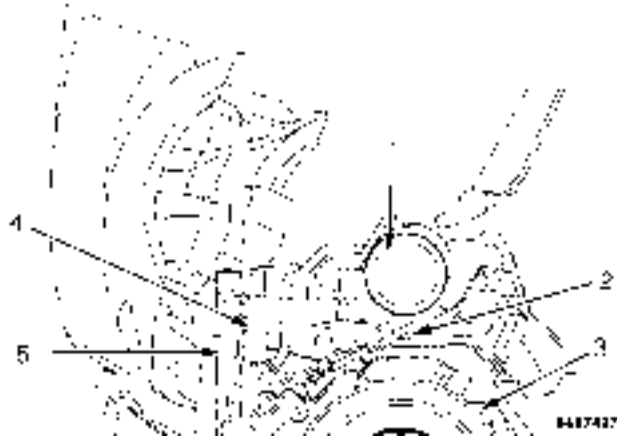

1. Air Cleaner: Check air cleaner element, housing, and hoses for loose connections or damage. Check air filter restriction gauge for restriction reading. For element replacement, see **Air Cleaner Element Service** in the **Maintenance Instructions** section.
2. Oil Level: Use dipstick to verify that the oil level is between the full and add marks.

3. Fuel/Water Separator: Check sight globe (if Davco equipped, inform maintenance personnel if fuel level is at top of globe, which is an indication that the filter is due for replacement) and drain into cup periodically. Inspect for presence of water, and drain water as necessary. Check for leaks.
  4. Power Steering Fluid: Verify that the fluid level is between the Cold or Hot (as applicable) MIN and MAX marks.
  5. Radiator and Charge Air Cooler: Check for loose mounting and damage. Inspect condition of all hoses for damage, cracks, and leaks. Inspect for foreign material on face of cooling package. Carefully brush away collected materials without bending cooling fins to maintain proper airflow through cooling package.
- Air Lines and Wiring: Check air Lines and electrical wiring for proper security, and for damage, and chafing. Listen for audible air leaks.
  - Leaks: Check for signs of fluid puddles under vehicle, or wet components in the engine compartment.

Left Front of Tractor

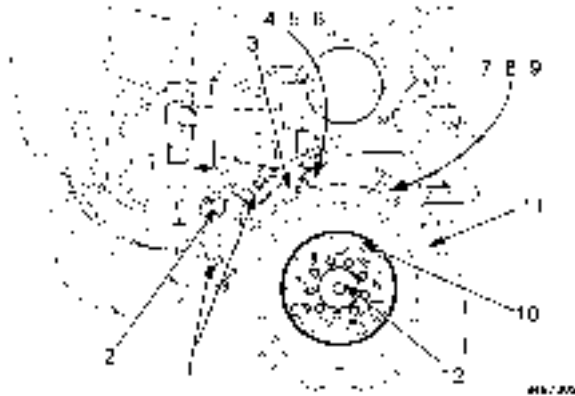

**If wheels or tires must be changed, obtain expert tire service help. Mounting and demounting of tires should only be performed by qualified personnel using necessary safety procedures and equipment, otherwise the result could be property damage, personal injury, or death.**



**Do not operate vehicle if any of the following conditions are evident. Loss of steering or suspension could cause loss of vehicle control and result in property damage, personal injury, or death.**

**NOTE:** Retread tires are not recommended for use on steering axles of trucks.

1. **Steering Linkage:** Inspect connecting links, arms, rods, and steering intermediate shaft for worn, damaged, loose, or missing components.
2. **Steering Gear:** Look for missing or loose fasteners, power steering fluid leaks, and damage to power steering hoses.
3. **Frame:** Check for cracks or bends in frame. Make sure there are no loose, cracked, bent, broken or missing crossmembers or crossmember fasteners.
4. **Spring Suspension:** Check condition of spring for cracks, breaks, or shifting. Inspect spring hanger fasteners, shackles, U-bolts, and nuts for wear, damage, and tightness.

## Inspection Guide

---

5. Shock Absorber: Check for cracks, leaks, and missing or broken mounting bolts or bushings.
6. Air Suspension (if equipped): Check for air leaks, loose components, and damage to air bag. Inspect stabilizer bar for worn, loose, or damaged components.
7. Brake Chamber and Hoses: Check to see that the brake chambers are not cracked or damaged, and are securely mounted. Check for broken, loose or missing parts. Check for cracked, worn or frayed hoses, and for secure couplings.
8. Slack Adjuster: Check slack adjuster and chamber push rod travel. When pulled by hand, push rod should not move more than approximately one inch. Angle between push rod and adjuster arm should be approximately 90 degrees when brakes are applied.
9. Brake Lining and Drum: With brakes released, check to see that brake linings (where visible) are not worn excessively thin [less than 1/4 inch (6mm)] or contaminated by lubricant.
10. Wheel and Lug Nuts: Check for damaged or bent wheel. Check to see that all lug nuts are present and not loose (look for rust trails around nuts). Ensure that no cracks or damage are present at wheel mount holes.
11. Tire: Check tread depth, tire inflation and note if tread is evenly worn. Minimum tread depth is 4/32 inch on steering tires. Look for cuts or other damage to the tread or sidewalls. Check for missing, broken or damaged valve cap and stem.
12. Hub: Check for obvious leaks on outside or inside of wheel. Verify correct oil level in hub.



### Front of Tractor

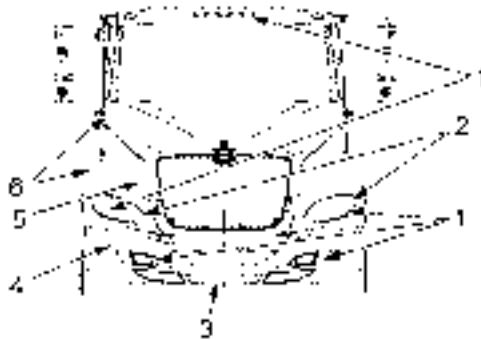

349/004

1. Lighting System: Lower hood and inspect parking, clearance, identification lights, turn signals, fog lights, and reflectors on hood, bumper, and cab. They should be clean, operational and the proper color.
2. Headlights: Lenses should be clean. If equipped, check daytime running lights.
3. Eaton VORAD Front Sensor (if equipped): Check for damage and proper mounting. Ensure sensor's view is clear of mud, dirt, ice or any material or objects.
4. Bumper: Inspect for damage and security.
5. Grille: Inspect for damage and security. Check bug screen for damage and cleanliness.
6. Hood and Fenders: Check hood panels and fenders for signs of breaks or damage. Ensure hood opens and closes properly.

### Right Front of Tractor

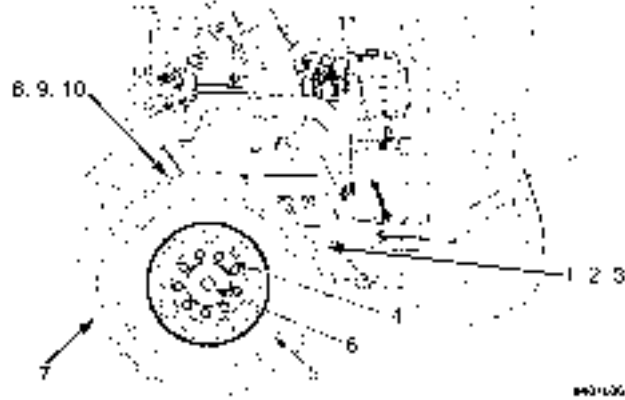

**If wheels or tires must be changed, obtain expert tire service help. Mounting and demounting of tires should only be performed by qualified personnel using necessary safety procedures and equipment, otherwise the result could be property damage, personal injury, or death.**



**Do not operate vehicle if any of the following conditions are evident. Loss of steering or suspension could cause loss of vehicle control and result in property damage, personal injury, or death.**

**NOTE:** Retread tires are not recommended for use on steering axles of trucks.

1. Spring Suspension: Check condition of spring for cracks, breaks, or shifting. Inspect spring hanger fasteners, shackles, U-bolts, and nuts for wear, damage, and tightness.
2. Shock Absorber: Check for cracks, leaks, and missing or broken mounting bolts or bushings.
3. Air Suspension (if equipped): Check for air leaks, loose components, and damage to air bag. Inspect stabilizer bar for worn, loose, or damaged components.

4. **Wheel and Lug Nuts:** Check for damaged or bent wheel. Check to see that all lug nuts are present and not loose (look for rust trails around nuts). Ensure that no cracks or damage are present at wheel mount holes.
5. **Tire:** Check tread depth, tire inflation and note if tread is evenly worn. Minimum tread depth is 4/32 inch on steering tires. Look for cuts or other damage to the tread or sidewalls. See if valve caps and stems are missing, broken or damaged.
6. **Hub:** Check for obvious leaks on outside or inside of wheel. Verify correct oil level in hub.
7. **Steering Linkage:** Inspect connecting links, arms, and rods for worn, damaged, loose, or missing components.
8. **Brake Chamber and Hoses:** Check to see that the brake chambers are not cracked or damaged, and are securely mounted. Check for broken, loose or missing parts. Check for cracked, worn or frayed hoses, and for secure couplings.
9. **Slack Adjuster:** Check slack adjuster and chamber push rod travel. When pulled by hand, push rod should not move more than approximately one inch. Angle between push rod and adjuster arm should be approximately 90 degrees when brakes are applied.
10. **Brake Lining and Drum:** With brakes released, check to see that brake linings (where visible) are not worn excessively thin [less than 1/4 inch (6mm)] or contaminated by lubricant.
11. **Frame:** Check for cracks or bends in frame. Make sure there are no loose, cracked, bent, broken or missing crossmembers or crossmember fasteners.

### Right Engine Compartment



To prevent personal injury or death from hot coolant or steam, use only the following procedure to remove the pressure cap from the radiator or expansion tank. Allow the engine to cool first. Wrap a thick, heavy cloth around the cap. Unscrew the cap slowly to allow pressure to release from under the cap. After the pressure has been released, the pressure cap may be removed.

1. **Coolant Level:** Do not remove pressure cap unless coolant is cool. Ensure fluid level is between the minimum and maximum fluid level range as marked on the plastic translucent reservoir.
  2. **Radiator and Charge Air Cooler:** Check for loose mounting and damage. Inspect condition of all hoses for damage, cracks, and leaks. Inspect for foreign material on face of cooling package. Carefully brush away collected materials without bending cooling fins to maintain proper airflow through cooling package.
  3. **Windshield Washer Fluid Level:** Inspect the reservoir and verify that the fluid level is not empty and has enough fluid to accomplish the upcoming mission. If additional fluid is required, see Lubricant and Sealer Specifications chart, in the **Maintenance Intervals and Specifications** section, for the correct fluid type before filling. Do not use water in freezing climates.
  4. **Drive Belts:** Inspect all belts for frays, cracks, loose fibers, or visible signs of wear. With engine off, press on all belts to test for proper belt tensioner performance
  5. **Cowl Vent:** Ensure air inlet cover is free of dirt and debris.
- **Air Lines and Wiring:** Check air Lines and electrical wiring for proper security, damage, and chafing. Listen for audible air leaks.

- Leaks: Check for signs of fluid puddles under vehicle, or wet components in the engine compartment.

## Right Side of Cab

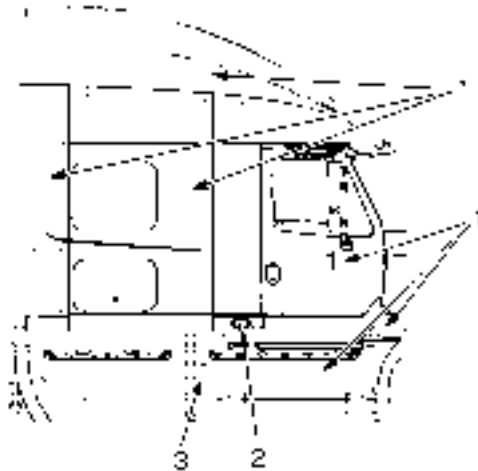

**Maintain adequate clearance between all parts of the exhaust system and all hoses, wires and lines for engine cooling, brake system, fuel system, power steering system and electrical system. Heat damage to hoses, wires may cause vehicle malfunction that could result in property damage, personal injury, or death.**

- Cab Structure:** Check body panels such as doors, fairings, air shield, and cab extenders for signs of breaks or damage. Check condition of cab mounting brackets and tilt hood latches.
- Fuel Tank:** Check to see that the fuel tank and cap are secured and make sure there is no damage or leaks at the tank or fuel lines.
- Eaton VORAD sensor (if equipped):** Check for damage and proper mounting. Ensure sensor's view is clear of mud, dirt, ice or any material or objects.

### Right Side Under Vehicle

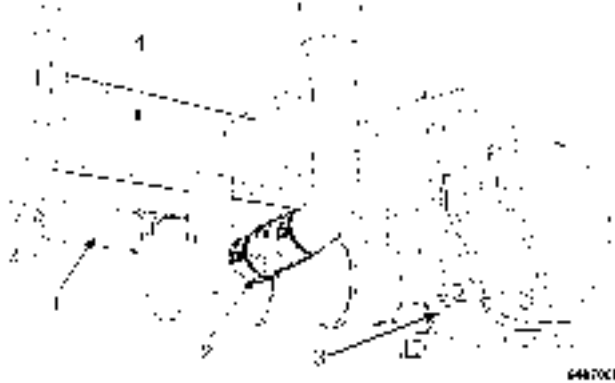

**Maintain adequate clearance between all parts of the exhaust system and all hoses, wires and lines for engine cooling, brake system, fuel system, power steering system and electrical system. Heat damage to hoses, wires or lines may cause vehicle malfunction that could result in property damage, personal injury, or death.**

1. Drive Shaft: Ensure that all shaft couplings are secure.
  2. Exhaust System: Check to see that all component parts are securely mounted and no cracks, holes, or severe dents are visible. Evidence of soot build up around clamps or connections is a clear indicator of a leak being present. Ensure that all hoses, wires, and air lines are secured away from exhaust components.
  3. Transmission: Inspect for leaks.
  4. Frame: Check for cracks or bends in frame. Make sure there are no loose, cracked, bent, broken or missing crossmembers or crossmember fasteners.
- Air Lines and Wiring: Check air Lines and electrical wiring for proper security, damage, and chafing. Listen for audible air leaks.

## Right Rear of Tractor

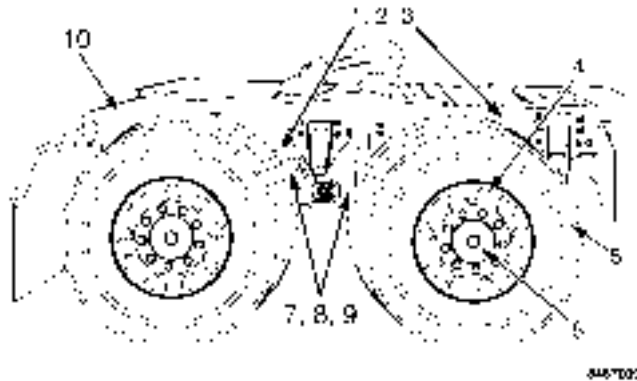

**If wheels or tires must be changed, obtain expert tire service help. Mounting and demounting of tires should only be performed by qualified personnel using necessary safety procedures and equipment, otherwise the result could be property damage, personal injury, or death.**

1. **Brake Chamber and Hoses:** Check for cracked, worn or frayed hoses, and for secure couplings. Check to see that the brake chambers are not cracked or dented and that they are securely mounted. Check for broken, loose or missing parts.
2. **Slack Adjuster:** Check slack adjuster and chamber push rod travel. When pulled by hand, push rod should not move more than approximately one inch. Angle between push rod and adjuster arm should be approximately 90 degrees when brakes are applied.
3. **Brake Lining and Drum:** With brakes released, check to see that brake linings (where visible) are not worn excessively thin [less than 1/4 inch (6mm)] or contaminated by lubricant.
4. **Wheel and Lug Nuts:** Check for damaged or bent wheel. Check to see that all lug nuts are present and not loose (look for rust trails around nuts). Ensure that no cracks or damage are present at wheel mount holes.

## Inspection Guide

---

5. Tires: Check tread depth, tire inflation and note if tread is evenly worn. Minimum tread depth is 2/32 inch on all drive tires. Look for cuts or other damage to the tread sidewalls. See if valve caps and stems are missing, broken or damaged. Check dual spacing to ensure that dual wheels are evenly separated, and that tires are not touching one another.
  6. Hub: Check for obvious leaking on outside or inside of wheel. Inspect axle flanges and wheel seals for leaks and loose mounting hardware or broken items. Check lube level, if equipped with sight glass.
  7. Spring Suspension: Check condition of spring for cracks, breaks, or shifting. Inspect spring hanger fasteners, shackles, U-bolts, and nuts for wear, damage, and tightness.
  8. Torque Rods and Shock Absorbers: Check to see that torque rods are not cracked, broken or missing. Check shock absorbers for cracks or leaks. There should be no missing or broken mounting bolts or worn bushings.
  9. Air Suspension (if equipped): Check for air leaks, loose components, and damage to air bag. Inspect ride height valve and linkage for damage.
  10. Frame: Check for cracks or bends in frame. Make sure there are no loose, cracked, bent, broken or missing crossmembers or crossmember fasteners.
- Air Lines and Wiring: Check air lines and electrical wiring for proper security, damage, and chafing. Listen for audible air leaks.



### Rear of Tractor

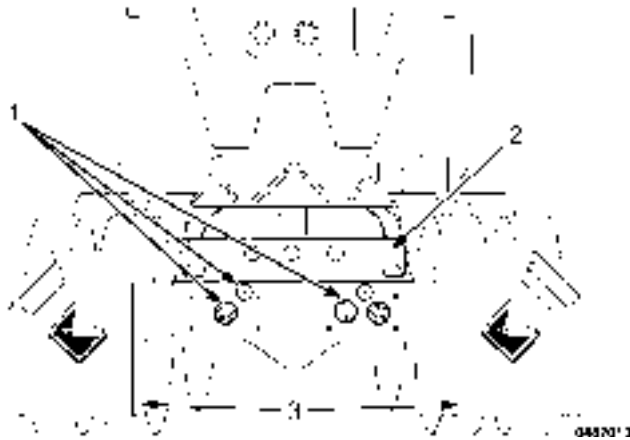

1. Lights and Reflectors: Check to see that reflectors and lights are clean. Make sure none are missing or broken. Rear running lights should be clean, not broken and red in color.
  2. Frame: Check for cracks or bends in frame. Make sure there are no loose, cracked, bent, broken or missing crossmembers or crossmember fasteners.
  3. Mud flaps: Inspect rear mud flaps and mountings for damage and proper security.
- Air Lines and Wiring: Check air Lines and electrical wiring for proper security, and for damage, and chafing. Listen for audible air leaks.

### Left Rear of Tractor

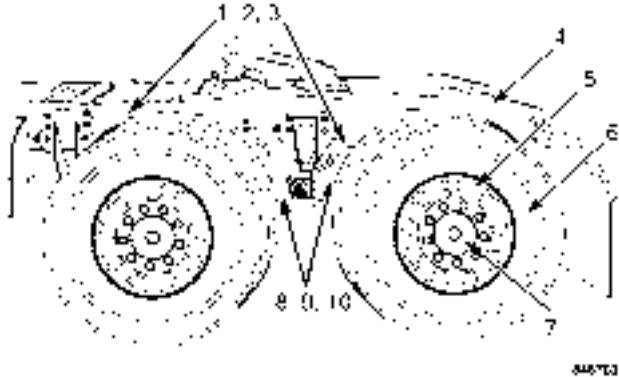

If wheels or tires must be changed, obtain expert tire service help. Mounting and demounting of tires should only be performed by qualified personnel using necessary safety procedures and equipment, otherwise the result could be property damage, personal injury, or death.

1. Brake Chamber and Hoses: Check for cracked, worn or frayed hoses, and for secure couplings. Check to see that the brake chambers are not cracked or dented and that they are securely mounted. Check for broken, loose or missing parts.
2. Slack Adjuster: Check slack adjuster and chamber push rod travel. When pulled by hand, push rod should not move more than approximately one inch. Angle between push rod and adjuster arm should be approximately 90 degrees when brakes are applied.
3. Brake Lining and Drum: With brakes released, check to see that brake linings (where visible) are not worn excessively thin [less than 1/4 inch (6mm)] or contaminated by lubricant.
4. Frame: Check for cracks or bends in frame. Make sure there are no loose, cracked, bent, broken or missing crossmembers or crossmember fasteners.

5. **Wheel and Lug Nuts:** Check for damaged or bent wheel. Check to see that all lug nuts are present and not loose (look for rust trails around nuts). Ensure that no cracks or damage are present at wheel mount holes.
  6. **Tires:** Check tread depth, tire inflation and note if tread is evenly worn. Minimum tread depth is 2/32 inch on all drive tires. Look for cuts or other damage to the tread and sidewalls. See if valve caps and stems are missing, broken or damaged. Check dual spacing to ensure that dual wheels are evenly separated, and that tires are not touching one another.
  7. **Hub:** Check for obvious leaking on outside or inside of wheel. Inspect axle flanges and wheel seals for leaks and loose mounting hardware or broken items. Check lube level, if equipped with sight glass.
  8. **Spring Suspension:** Check condition of spring for cracks, breaks, or shifting. Inspect spring hanger fasteners, shackles, U-bolts, and nuts for wear, damage, and tightness.
  9. **Torque Rods and Shock Absorbers:** Check to see that torque rods are not cracked, broken or missing. Check shock absorbers for cracks or leaks. There should be no missing or broken mounting bolts or worn bushings.
  10. **Air Suspension (if equipped):** Check for air leaks, loose components, and damage to air bag. Inspect ride height valve and linkage for damage.
- **Air Lines and Wiring:** Check air Lines and electrical wiring for proper security, damage, and chafing. Listen for audible air leaks.

### Fifth Wheel and Coupling Area

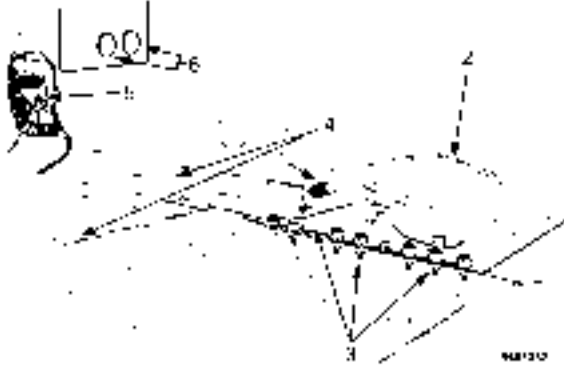

1. Sliding 5th Wheel (if equipped): Check for loose or missing pins in the slide mechanism. If air powered, check for air leaks. Make sure that 5th wheel is not so far forward that tractor frame or mud flaps will strike trailer landing gear during turns.
2. Lubrication: Make sure that top surface (face) of the 5th wheel has a coat of grease.
3. Mounting Bolts and Release Handle: Look for loose or missing mounting brackets, clamps, bolts or nuts. All locking pins must be in place and free of damage. Ensure that release handle is in the engaged position and the safety latch is functioning and free of damage.
4. Deck Plate and Access Steps: Check to ensure that the deck plate and steps are clean, securely bolted in place, and clear of loose objects.
5. Trailer Coupling Cords: Inspect air lines and electrical cord for cuts, chafing, damage, and proper security. Check air lines for audible air leaks.
6. Work Light(s): Check operation, and clean as needed.

### Cab Interior Inspection

1. Safety/Emergency Equipment: Prior to entering cab, verify that vehicle is equipped with the proper equipment. Walk around vehicle and check that all steps and grab handles, inside and out, as well as behind, are tight and clean. Use extreme caution and maintain 3 point contact at all times.
2. Doors: Check door latches for positive closing, latching and locking.
3. Clutch/Gearshift: Depress clutch pedal (if present) and verify transmission is in neutral before turning on starter; keep depressed until engine reaches idling speed and vehicle in neutral.
4. Oil Pressure Builds: Check to see that oil pressure is building to a normal level. Engine oil pressure gauge should begin a gradual rise to normal operating range.
5. Low Air Alarm: The low air pressure alarm may sound immediately after the engine starts but before the air compressor has built up minimum 55 psi (379 kPa) pressure. The low air pressure alarm should stop when the air pressure reaches 60 to 76 psi (414 to 524 kPa). Let the air pressure build to governor cut-out pressure, which should occur between 115 and 130 psi (793 and 896 kPa).
6. Accelerator: Depress accelerator pedal and verify that it operates smoothly without any binding or irregular feel. Remove foot from accelerator and make sure engine returns to idle immediately.
7. Voltmeter: Check the gauge to see if the alternator is charging between 12.5 and 14.5 volts.
8. Steering Play: Check for smooth operation. Check for excessive looseness in the steering linkages. The steering wheel should have less than 10 degrees free play (approximately 2 inches at rim of 18 inch steering wheel).
9. Seats: Be sure seats are firmly engaged to avoid forward or rearward movement when starting or stopping. Make sure that seats and tether straps are free from damage and secured to floor.
10. Horn(s): Check to see that horn(s) operate properly.
11. Mirrors: Check mirrors for proper adjustment, damage, cleanliness, and proper mounting. Check (optional) power mirrors and (optional) heated mirrors for proper operation.
12. Doors: Ensure windows are clean and operate properly and smoothly in both doors.
13. Windshield and Wipers: Check windshield for cracks, dirt, illegal stickers or other obstructions to view. Ensure wipers and windshield washer are functioning properly.
14. Lighting Indicators: Check to see that dash indicators illuminate when corresponding lights are turned on.
15. Heater/Defroster: Check to be sure that heater/defroster is working. Verify adequate air flow from louvers and vents. Operate Temperature and Mode controls to verify proper operation.

16. Air Brake Check: Check the air brakes in the following manner:
- a. Chock wheels if necessary. Push in parking brake and start engine.
  - b. Check for air compressor or governor cut-out pressure at 125 to 135 psi (862 to 931 kPa). Shift into a low gear, and gently pull against service and parking brakes separately to make sure they hold.
  - c. Shut off engine and TURN KEY BACK ON.
  - d. Without brake pedal applied, note air pressure drop for one minute. It should be less than 2 psi (14 kPa).
  - e. Depress and hold brake pedal and make sure there is no more than a 3 psi (21 kPa) per minute pressure drop. For combination vehicles, there should be no more than 4 psi (28 kPa) per minute pressure drop.
  - f. Step on and off brake pedal and check that warning indicator and alarm come on at about 60 or 76 psi (414 or 524 kPa).
  - g. Step on and off brake pedal and check to make sure the parking brake knobs pop out between 20 and 45 psi (138 and 310 kPa).

## SECTION 4 — CONTROLS/FEATURES

### Introduction

#### General Information

The controls/features enable the driver to monitor and manage the operation of the majority of the vehicle's functions. This section describes and identifies various components within the Overhead Console, Instrument Panel Gauge Cluster, Center Dash Panel/Wing Panel, Steering Column and Switches, Steering Wheel Controls, Door and Window Controls, Eaton VORAD Collision Warning System, and Vehicle Information Display.

#### Electrical



**This vehicle may be equipped from the factory with electrical switches intended to operate equipment that was installed by a truck equipment manufacturer (TEM). Instructions, Cautions, and Warnings for this additional equipment will NOT be found in this manual. Read and understand the appropriate manual for the specific equipment in question before operating. Failure to observe this warning may cause property damage, personal injury, or death.**

**NOTE:** This vehicle may be equipped with electronic, application specific options not described in this Operator's Manual. Many of these features are supplied with rocker switches that have custom labels applied. The presence of these options as factory installed can be verified from the Line Set Ticket included with the vehicle. A truck equipment manufacturer (TEM), however, may have installed some of these options after production. In that case, they will not appear on the Line Set Ticket. If installed by a TEM, you should receive an operating guide and/or training for the specific functions provided. Familiarize yourself with all of the switches that control chassis, engine, and body equipment and seek adequate training on the function of all features before operating this vehicle.

#### Electrical System

The Electrical System provides a means to distribute the electrical power and provide the driver with controls and indications of vehicle performance. Unlike previous electrical systems, this system uses multiplexing for connecting to major functional areas of the truck with much less wiring. The system is controlled by the Body Controller, which provides interfaces to a majority of vehicle switches and sensors. The Body Controller also communicates with the standard and optional system controllers and modules in the vehicle.

### Dash Components

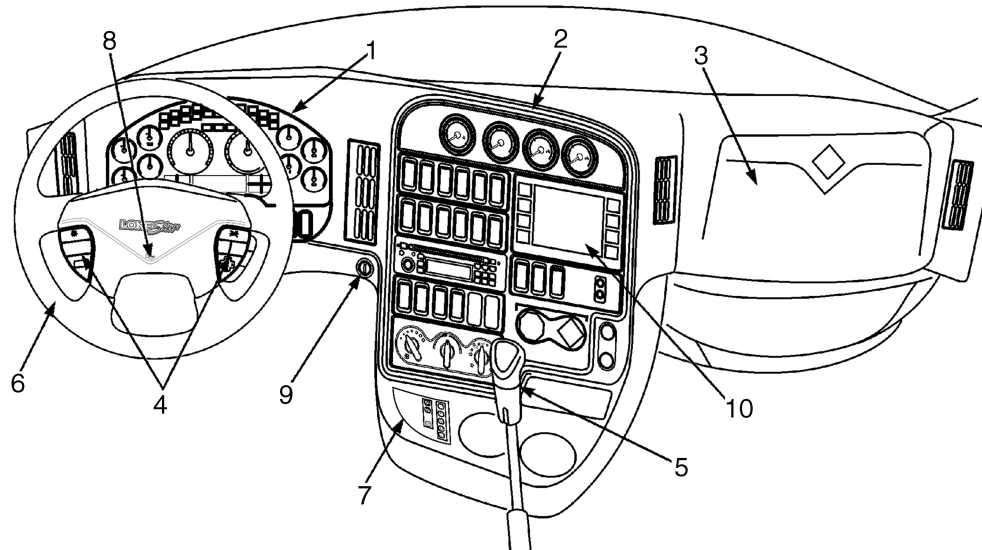

3817002

- |  |  |
|--|--|
| 1. Instrument Panel Gauge Cluster  | 6. Tilt/Telescoping Steering Column                                      |
| 2. Center Dash Panel/Wing Panel  | 7. Push Button Gear Selector for Optional Automated Manual Transmission. |
| 3. Fuse Panel Cover  | 8. City Horn Pad   |
| 4. Control Switches  | 9. Ignition Switch   |
| 5. Transmission Gear Switch with Hi/Lo Range Switch and Optional Hi/Lo Splitter Switch | 10. Vehicle Information Display (optional)                               |



## Overhead Console

The overhead console contains storage area for the operator, and other items for driver comfort.

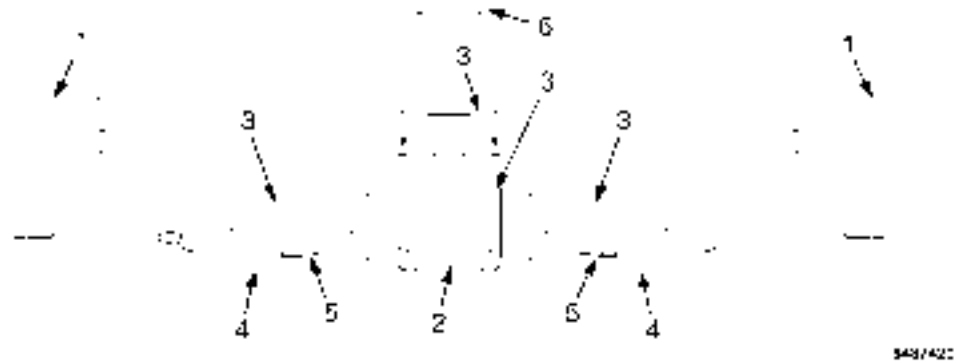

- |                        |                      |
|------------------------|----------------------|
| 1. Overhead Storage    | 4. Sun Visors        |
| 2. CB Radio Mount      | 5. Map Lights        |
| 3. Storage Compartment | 6. Cab Dome Lighting |

### **Instrument Panel Gauge Cluster**

The instrument panel gauge cluster includes the instrument gauges, warning indicators, and an Integral Digital Display, that provide odometer, transmission gear indication, and compass

heading and outside temperature displays. This instrument panel gauge cluster displays the crucial operational functions of the vehicle. The following are descriptions and illustrations of the gauges, warning indicators, and integral digital display options.

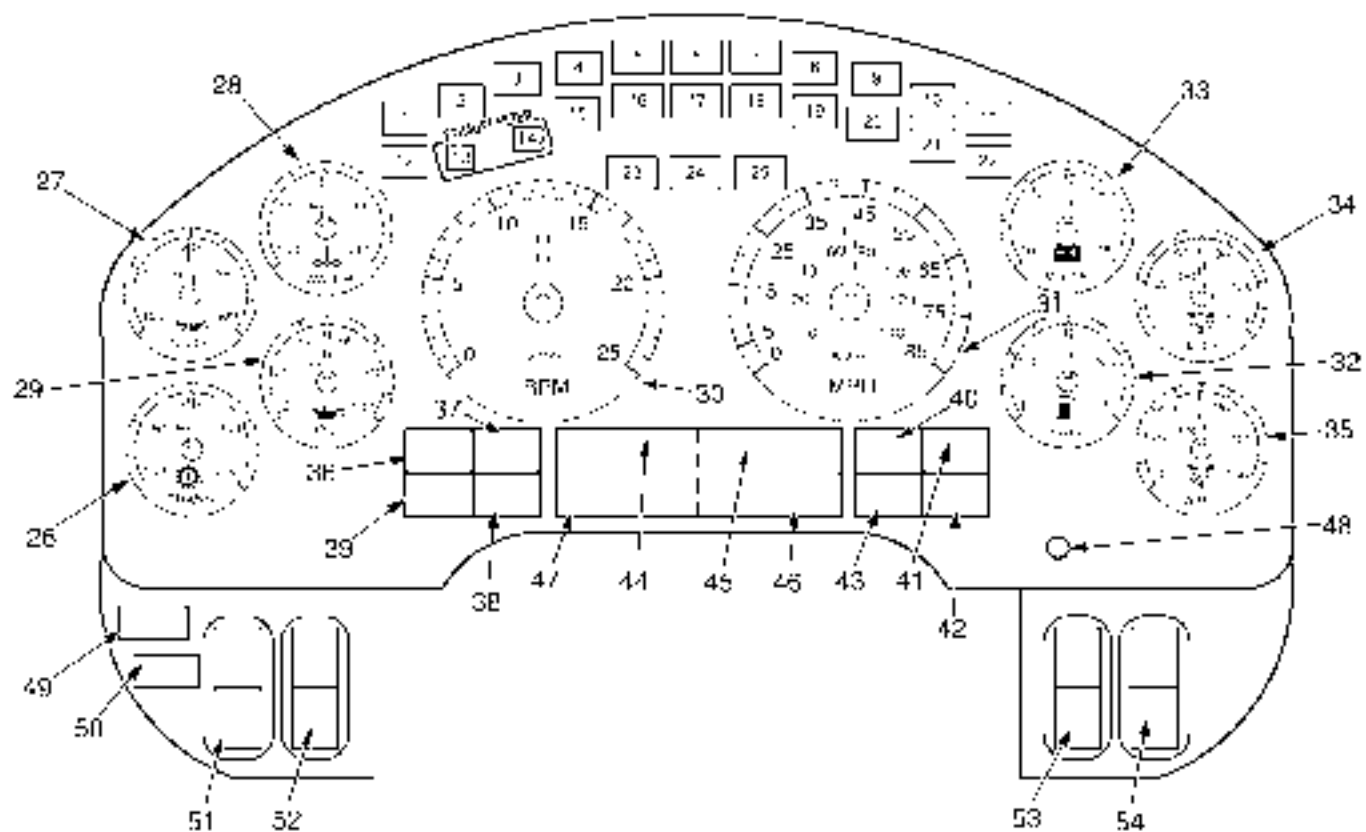









818r100





## Controls/Features





### Warning Indicators

The instrument panel gauge cluster contains 25 individual LED warning indicators. These indicators are used to monitor vehicle operation and indicate a WARNING or STOP condition. These warning indicators are driven by the software in the instrument panel gauge cluster. At ignition, the warning indicators will illuminate for 8 to 10 seconds, as part of the vehicle power-up sequence.



| Item No. | Item   | Description   |
|----------|--|---|
| 1        |   | Illuminates <b>Yellow</b> when the intake heaters and glow plugs are in operation and special starting procedures are required. Refer to the Starting Switch paragraph in the Vehicle Operation section for more information. |
| 2        |   | Illuminates <b>Yellow</b> to alert driver that vehicle idle shutdown timer will turn engine off in 30 seconds.  |
| 3        |  | Illuminates <b>Yellow</b> . Used in conjunction with other Warning Indicators or General Text and Warning Messages and may be accompanied by an audible alarm to indicate an Alert condition to the operator.                 |

|    |   |   |
|----|---|---|
| 4  |  | Illuminates <b>Yellow</b> . Used in conjunction with other Warning Indicators or General Text and Warning Messages to indicate an Alert condition to the operator.                                |
| 5  |  | Illuminates <b>Red</b> Used in conjunction with other Warning Indicators or General Text and Warning Messages to indicate a red STOP alert.   |
| 6  |   | Not Used.   |
| 7  |  | Illuminates <b>Red</b> when the parking brake is applied. If the brake warning indicator does not illuminate, or if it stays on with the parking brake not engaged, seek service immediately.     |
| 8  |  | Illuminates <b>Green</b> to assist operators in determining when it is appropriate to shift the transmission to a higher gear in order to maximize driving fuel economy.                          |
| 9  |  | Illuminates <b>Yellow</b> to indicate engine brake capability has been activated.   |
| 10 |  | Illuminates <b>Yellow</b> when a trailer antilock brake system malfunction has been detected. If the ABS indicator stays illuminated or continues to flash, have the system serviced immediately. |

|    |   |   |
|----|---|---|
| 11 |  | Illuminates <b>Yellow</b> when the traction control system is turned off. It also illuminates momentarily when the traction control system is on and is limiting wheel spin. Indicator blinks if slippery road conditions exist. If this happens, adjust your driving accordingly. Refer to the Operation section for more information. |
| 12 |   | Not used.   |
| 13 |  | Illuminates <b>Yellow</b> when exhaust system components are operating under normal conditions and exhaust gases are at extremely high temperatures.  |
| 14 |  | Diesel Particulate Filter (DPF) status indicator Illuminates <b>Yellow</b> (Solid or Flashing) to indicate the need to regenerate the Diesel Particulate Filter. (See Exhaust Regen in the Vehicle Operation Section).  |
| 15 |  | Engine Emissions Control System Malfunction Indicator Lamp (MIL)<br><br>Illuminates <b>Yellow</b> when an emissions problem has occurred.   |

|    |  |   |
|----|--|---|
| 16 |   | Illuminates <b>Red</b> when a parking brake system malfunction has been detected. If the Service Parking Brake indicator stays illuminated, have the system serviced immediately.   |
| 17 |   | Optional indicator illuminates <b>Red</b> immediately after ignition is turned on to remind operator to fasten seat belt.<br><br>Optional Seat Belt Reminder with Seat Belt Monitoring causes initial visual indication, then flashes with audible alarm when ignition is on, parking brake is released, and seat belt is not fastened. |
| 18 |  | Not used.   |
| 19 |  | Not used.   |
| 20 |   | Illuminates <b>Yellow</b> when the PTO function (if installed) is activated.  |
| 21 |   | Illuminates <b>Yellow</b> when an antilock brake system malfunction has been detected. If the ABS indicator stays illuminated or continues to flash, have the system serviced immediately.  |
| 22 |  | Not used.   |
| 23 |  | Flashes <b>Green</b> when the left turn signal or the hazard lights are turned on.  |





## Controls/Features

|    |   |   |
|----|---|---|
| 24 |  | Illuminates <b>Blue</b> when the high beam head lamps are turned on.                |
| 25 |  | Flashes <b>Green</b> when the right turn signal or the hazard lights are turned on. |



**NOTE:** If the MIL is illuminated, it is the vehicle owner's responsibility to have the engine repaired or face fines.

### Gauges

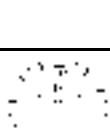
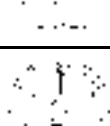
There are 10 gauges in the instrument panel gauge cluster to help monitor the vehicle while in service. Most gauges have in-gauge warning indicators which turn on if the gauge pointer moves into an out-of-acceptable-range condition. When the ignition switch is turned on, the gauge indicators will be on. If any indicator fails to go out after starting engine, stop engine and determine cause of the gauge indication that is out of acceptable range. Metric versions of the gauges and speedometer are available as an option.

|    |  |  |
|----|--|--|
| 26 |   | Indicates the transmission lubricant temperature in degrees Fahrenheit (°F) (optional).  |
| 27 |   | Indicates the engine lubricant temperature in degrees Fahrenheit (°F) (optional).  |
| 28 |   | Indicates engine coolant temperature in degrees Fahrenheit (°F).   |
| 29 |   | Indicates engine oil pressure in pounds per square inch (PSI).   |
| 30 |   | The tachometer indicates engine speed (RPM). The engine can be operated between idle speed and high idle speed without damage but should not be allowed to over-speed (such as when going downhill). |
| 31 |   | The speedometer indicates the vehicle speed in miles per hour (MPH) and kilometers per hour (Km/h).  |
| 32 |  | Indicates the approximate fuel level in the fuel tanks.  |

|    |   |  |
|----|---|--|
| 33 |  | <p>Indicates the battery voltage (VOLTS) when the ignition switch is in the ON position.</p> |
|----|---|--|

|    |   |  |
|----|---|--|
| 34 |  | <p>Provides indication of air pressure available for the primary air brakes in pounds per square inch (PSI).</p>   |
| 35 |  | <p>Provides indication of air pressure available for the secondary air brakes in pounds per square inch (PSI).</p> |

## Controls/Features

### Instrument Panel Gauge Cluster Alarms



**When an alarm sounds, stop normal vehicle operation and determine the source of the alarm condition. Failure to observe this instruction could result in property damage, personal injury, or death.**

The instrument panel gauge cluster will sound an audible alarm that accompanies out of range gauge readings along with the particular gauge warning indicators. The instrument panel gauge cluster alarms will also sound when any engine sensor (sender) unit fails; when there is an electronics system fault; and when the red engine indicator is illuminated. The following chart lists the number of alarm beeps for the above conditions or warning states:

| Alarm Conditions  | Audible Alarm Pattern | Additional Comments   |
|---|-----------------------|---|
| <b>Fuel level gauge</b> low (only alarms on each ignition turn-on)  | 5 BEEPS               | Instrument panel gauge cluster warning indicator illuminates. |
| <b>Voltmeter gauge</b> out-of-range reading                         | 5 BEEPS               | Instrument panel gauge cluster warning indicator illuminates. |
| <b>Engine oil pressure gauge</b> out-of-range reading               | 5 BEEPS               | Instrument panel gauge cluster warning indicator illuminates. |
| <b>Engine oil temperature gauge</b> out-of-range reading            | 5 BEEPS               | Instrument panel gauge cluster warning indicator illuminates. |
| <b>Engine coolant temperature gauge</b> out-of-range reading        | 5 BEEPS               | Instrument panel gauge cluster warning indicator illuminates. |
| <b>Transmission oil temperature gauge</b> out-of-range reading      | 5 BEEPS               | Instrument panel gauge cluster warning indicator illuminates. |
| <b>Rear-Rear Axle oil temperature gauge</b> out-of-range reading    | 5 BEEPS               | Instrument panel gauge cluster warning indicator illuminates. |
| <b>Forward-Rear Axle oil temperature gauge</b> out-of-range reading | 5 BEEPS               | Instrument panel gauge cluster warning indicator illuminates. |







| Alarm Conditions   | Audible Alarm Pattern | Additional Comments  |
|--|-----------------------|--|
| <b>Auxiliary air pressure gauge</b> out-of-range reading                       | 5 BEEPS               | Instrument panel gauge cluster warning indicator illuminates.  |
| <b>Gauge sensor faults</b>   | 3 BEEPS               | Gauge pointer goes to 6 o'clock position and gauge warning indicator illuminates.  |
| <b>Primary Air Pressure gauge</b> out-of-range and air pressure sensor fault   | REPEATING SINGLE BEEP | Instrument panel gauge cluster warning indicator illuminates.  |
| <b>Secondary Air Pressure gauge</b> out-of-range and air pressure sensor fault | REPEATING SINGLE BEEP | Instrument panel gauge cluster warning indicator illuminates.  |
| <b>Red warning</b> indicator illuminates                                       | REPEATING SINGLE BEEP | Indicates what module is requesting the red stop indicator.  |
| <b>Electrical system fault</b>   | 10 BEEPS              | Electrical system fault illuminates.   |
| <b>Turn Signal Alarm</b> (Optional)  | CONTINUOUS TONE       | Alarm sounds if either turn signal is on for more than one mile.<br><br>Will not activate when hazard flashers are on.   |
| <b>Headlight Warning Alarm</b>   | 5 BEEPS               | Sounds one time immediately after ignition switch is turned to OFF position, when headlight switch is on, and the drivers door is closed.  |
|  | REPEATING SINGLE BEEP | Sounds when headlight switch is on, ignition switch is in OFF position, and the drivers door is open.  |
| <b>Electrical Load Control and Shedding (ELCS) Alarm</b> (Optional)            | CONTINUOUS TONE       | The Instrument panel gauge cluster will display the message "Load Shedding" in the LCD display and emit a continuous tone for 5 seconds that coincides with the start of the visual alert. |

## Controls/Features

### Direct Drive Warning Indicators

The direct drive warning indicators give information to the operator of various conditions of the vehicle. Eight spaces are available for the direct drive warning indicators. Blank cover plates will be used in spaces that do not have direct drive warning indicator installed at those locations.

| Item No. | Item  | Color  | Description                               |
|----------|---|--------|---|
| 36       |  | Yellow | Forward rear axle differential is locked. |
| 37       |  | Yellow | Rear axle differential is locked.         |
| 38       | <b>BLANK</b>  |        | Not used                                  |
| 39       |  | Yellow | ICON system is activated.                 |
| 40       | <b>BLANK</b>  |        | Not used                                  |
| 41       | <b>BLANK</b>  |        | Not used                                  |

| Item No. | Item  | Color  | Description                           |
|----------|---|--------|---------------------------------------|
| 42       |  | Yellow | Luggage door is ajar.                 |
| 43       |  | Yellow | Engine brake capability is activated. |

### Integral Digital Display

The Integral Digital Display is located below the speedometer and the tachometer. It is arranged in four quadrants that display vehicle information. The four quadrants can be individually selected by using the display control button.

**Display Control.** The Display control is used to scroll to a quadrant and to select the various modes within a quadrant. To navigate between quadrants, turn and release the control either clockwise or counterclockwise. To select the screens within a quadrant, press and release the control. Pressing and holding the control for more than 3 seconds to reset the value of the selected quadrant parameter (if the parameter can be reset). The selected quadrant is identified by a vertical bar located in the far right of quadrant. In quadrant 1, the odometer screen can be toggled between English and Metric, by pressing and holding the control.

| Item No. | Quadrant Number and Message Function     | Message Description   |
|----------|--|---|
| 44       | Quadrant 4: Transmission Gear Indication | Transmission gears for the Allison P-R-N-D-L gear selection display, or the Eaton Transmission display. |

| Item No. | Quadrant Number and Message Function          | Message Description   |
|----------|---|---|
| 45       | Quadrant 1: Informational Messages            | Informational Display Screens: <ul style="list-style-type: none"> <li>• Odometer</li> <li>• Trip Odometer</li> <li>• Total Engine Hours</li> <li>• Trip Hours</li> <li>• Machine PTO A or B Hours</li> <li>• Machine Trip PTO A or B Hours</li> <li>• Engine PTO Hours</li> <li>• Engine PTO Trip Hours</li> <li>• Instantaneous Fuel Economy</li> <li>• Trip Average Fuel Economy</li> <li>• Machine PTO Fuel Used A or B</li> <li>• Machine PTO Trip Fuel Used A or B</li> <li>• Engine PTO Fuel Used</li> <li>• Engine PTO Trip Fuel Used</li> <li>• Trip Idle Fuel Used</li> <li>• Axle Load Indication (Front and/or Rear)</li> <li>• Diesel Particulate Filter Level</li> </ul> |
| 46       | Quadrant 2: General Text and Warning Messages | Displays a variety of messages ranging in priority necessary for vehicle monitoring and operation, and vehicle malfunction warnings. Some messages are used in conjunction with instrument panel gauge cluster warning indicators (see list of messages in the Integral Digital Display section in Vehicle Operations)  |

## Controls/Features

| Item No. | Quadrant Number and Message Function            | Message Description   |
|----------|---|---|
| 47       | Quadrant 3: Compass Heading/Outside Temperature | <b>(Optional)</b> Displays compass heading when vehicle is equipped with a compass module.<br><br>Displays outside temperature (reading is obtained from the temperature sensor). |
| 48       | Display Control                                 | Toggles the information display from one screen to the next when pressed and released.  |

### General Text and Warning Messages

The operator of the vehicle can make adjustments to the sleeper temperature and/or sleeper blower speeds by using the SLPR TEMP and/or SLPR FAN dash switches that are located on the center dash panel/wing panel. When the operator makes a change with either of these two switches the appropriate graphic for the sleeper temperature or sleeper blower speeds will be displayed in the general text and warning message area of the instrument panel gauge cluster.



|                      |             |
|----------------------|-------------|
| Temperature Graphic  | <br>8487216 |
| Blower Speed Graphic | <br>8487217 |

### Optional Instrument panel gauge cluster Compass Calibration Procedure

All new vehicles with an optional compass must have an initial compass calibration performed. A compass calibration may or may not have been completed at the vehicle assembly plant. If the compass headings are noticeably incorrect, or become noticeably incorrect, or the NO CAL message is displayed, the Declination Zone may need to be reset to agree with the current geographic location, or the Compass Directional Calibration will need to be recalibrated.

The compass direction is displayed in the lower left quadrant of the instrument panel gauge cluster display just below the outdoor temperature reading. Text messages necessary to calibrate the compass can be found in the instrument panel gauge cluster display in the lower right quadrant (quadrant 2) of the display. Twist the instrument panel gauge cluster display knob until the cursor is flashing in the lower right quadrant. Press the instrument panel gauge cluster display knob until the desired text message is displayed. Compass Calibration related text messages include "Calibrate Compass", "Compass Declination", "Declination Zone #", and "End Calibration".

**NOTE:** The Declination Zone for the location where the Compass Calibration procedure is being performed must be set **first**, and thereafter the Compass Directional Calibration procedure can be performed. Both procedures are listed on the following pages and must be followed **exactly** to ensure proper calibration of the compass.

### *Compass Declination Zone Set Procedure*

The Declination Zone number is used to account for the errors between magnetic North and true North in the vehicle's geographic operating area, and must be set correctly for the compass to display accurate headings.

**NOTE:** When calibrating/recalibrating the compass, you must select the Declination Zone which corresponds to the geographic location where the compass calibration is being performed. It can be reset later to match the Declination zone where the vehicle will be operating.

For vehicles that regularly operate coast-to-coast or in several different Declination Zones, either choose a Declination Zone in the geographic center of the vehicle's operating area, or change the Declination Zone daily to match the present Declination Zone.

To begin the Declination Zone set procedure, the vehicle must be stopped with ignition key ON. Refer to Zone Map for determining the proper Declination Zone number.

Declination Zone Map

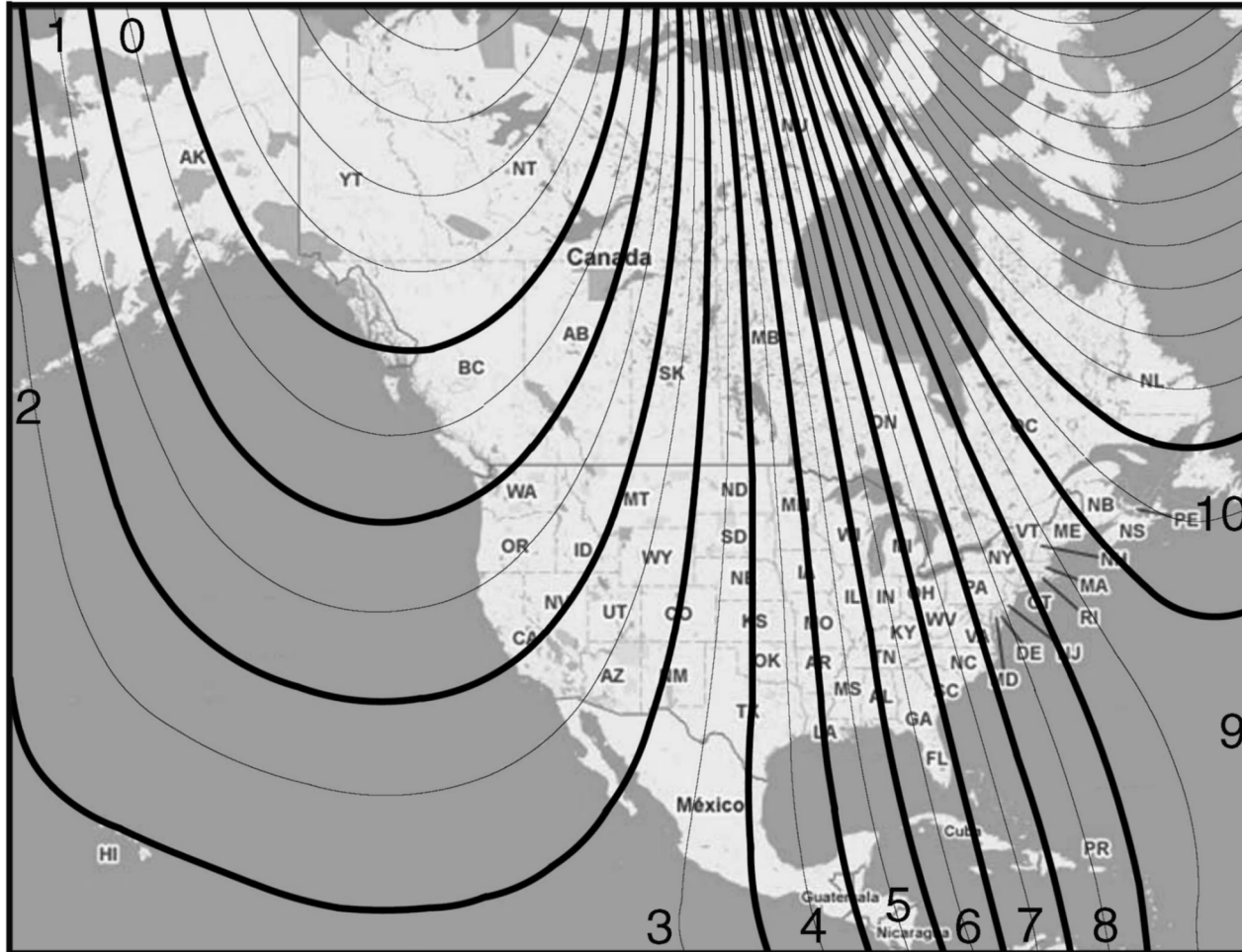

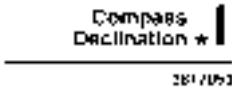
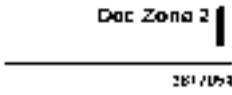
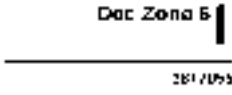
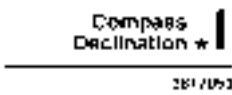

8487229

| Step | Procedure   | Displayed Message   |
|------|---|---|
| 1    | Select Quadrant 2 (lower right) on the display by turning the display control knob either clockwise or counterclockwise.  |    |
| 2    | Select the Compass Declination message by pressing and releasing the display control knob until this message appears.   |    |
| 3    | Press and hold the display control knob until any Declination Zone number (0 – 10) is displayed.  |    |
| 4    | <p>Turn the display control knob clockwise or counterclockwise until the desired Declination Zone number is displayed. Refer to Declination Zone Map to determine the proper number for the current geographic location.</p> <p><b>NOTE:</b> If no Declination Zone number is selected within 15 seconds, the display will return to the Compass Declination message.</p> <p><b>NOTE:</b> If the compass is being calibrated/recalibrated the Declination Zone must be set to the Zone number for the location where the compass calibration/recalibration is being performed regardless of the location where the vehicle will eventually operate.</p> |    |
| 5    | Press and <b>HOLD</b> the display control knob until the Compass Declination message appears (this indicates that the new Declination Zone number has been programmed into the compass).  |  |

## Controls/Features

### Compass Directional Calibration Procedure

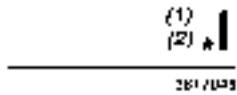
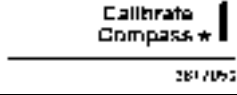
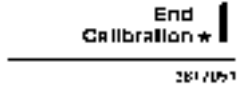
To begin the Compass Directional Calibration Procedure, stop the vehicle in an area large enough to permit driving in complete circles and perform the following steps:

| Step | Procedure  | Displayed Message  |
|------|--|--|
| 1    | Select Quadrant 2 (lower right) on the instrument panel gauge cluster display by turning the display control knob either clockwise or counterclockwise.  |  The image shows a portion of the instrument panel gauge cluster display. A horizontal line is drawn across the display. Above the line, the number '(1)' is positioned above '(2)'. To the right of '(2)' is a small star icon. Below the line, the text '381 / 093' is visible. |
| 2    | Select the Calibrate Compass message by pressing and releasing the display control knob until this message appears.  |  The image shows a portion of the instrument panel gauge cluster display. A horizontal line is drawn across the display. Above the line, the text 'Calibrate Compass' is displayed, followed by a small star icon. Below the line, the text '381 / 093' is visible.               |
| 3    | Press and hold the display control knob until the End Calibration command is displayed.<br><b>NOTE:</b> IF the End Calibration command will not show up, turn OFF the vehicle, restart it, and return to Step 1.<br><b>NOTE:</b> The following steps (4 through 6) must be completed within 3 minutes to lock-in the new calibration. <b>Do not press the display control knob or turn the key OFF until these steps are completed or the calibration process will be cancelled.</b> |  The image shows a portion of the instrument panel gauge cluster display. A horizontal line is drawn across the display. Above the line, the text 'End Calibration' is displayed, followed by a small star icon. Below the line, the text '381 / 093' is visible.                 |
| 4    | Immediately following the End Calibration command being displayed, drive the vehicle in 3 complete circles (during this time the compass display will go blank or have dashed lines present).  |  The image shows a portion of the instrument panel gauge cluster display. A horizontal line is drawn across the display. Below the line, there is a small star icon. Below the star icon, the text '381 / 093' is visible.   |

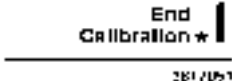
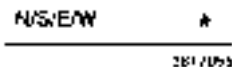
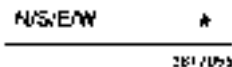

|          |  |   |
|----------|--|---|
| <p>5</p> | <p>Stop the vehicle and wait shortly. The End Calibration message should reappear on the display.</p>  |  |
| <p>6</p> | <p>Push and <b>HOLD</b> the display control knob until the End Calibration command disappears. The calibration should now be complete. <b>IMPORTANT!: Just pressing and failing to hold the display control knob inward until the End Calibration command disappears will cancel the calibration procedure and you must start over at Step 1.</b></p>  |  |
| <p>7</p> | <p>Test the compass calibration. Turn the vehicle ignition key OFF and then restart the vehicle. Wait 10 seconds to for the compass to complete its self test. Drive the vehicle in a circle and note the compass readings. If the lower left quadrant of the Instrument Panel Gauge Cluster Display shows the correct compass/vehicle heading, the compass calibration is now complete. If the compass readings are incorrect, inspect for correct Declination Zone number, turn OFF the vehicle, restart the vehicle, wait 10 seconds, and perform another circle while periodically noting the compass readings. If readings are still incorrect restart the compass calibration procedure.</p> |  |

## Controls/Features

---

### Integral Digital Display Detailed Information

#### Quadrant 1: Informational Displays

**NOTE:** The available display screens are dependant on the configuration of the vehicle.

| Quadrant 1 – Display Messages | Description  |
|-------------------------------|--|
| Odometer                      | <p>The odometer displays the total distance traveled.</p> <p><b>Display Format:</b></p> <p>100,000.0<br/>TRIP MILES<br/>TRIP KM</p>  |
| Trip Odometer                 | <p>The trip odometer displays a record of the elapsed distance traveled since the last reset.</p> <p><b>NOTE:</b> The trip hours and trip miles are independently reset.</p> <p><b>Display Format:</b></p> <p>100,000.0<br/>TRIP MILES<br/>TRIP KM</p>         |
| Total Engine Hours            | <p>The Engine Hour display provides a record of accumulated engine hours, and will not show any increase unless the engine is running.</p> <p><b>NOTE:</b> This display function cannot be reset.</p> <p><b>Display Format:</b></p> <p>100,000.0<br/>HOURS</p> |

| Quadrant 1 – Display Messages | Description   |
|-------------------------------|---|
| Trip Hours                    | <p>The Trip Hour display provides a record of elapsed engine hours since the last reset.</p> <p><b>NOTE:</b> The trip hours and trip miles are independently reset.</p> <p><b>Display Format:</b></p> <p>100,000.0<br/>TRIP HOURS</p> |
| Machine PTO A or B Hours      | <p>This display will provide a record of the total accumulated Machine PTO hours, while PTO function A or B is engaged.</p> <p><b>Display Format:</b></p> <p>100,000.0<br/>PTO HOURS A<br/>PTO HOURS B</p>                            |
| Machine Trip PTO A or B Hours | <p>This display will provide a record of the total accumulated Machine Trip PTO hours, while PTO function A or B is engaged.</p> <p><b>Display Format:</b></p> <p>100,000.0<br/>PTO TRP HOURS A<br/>PTO TRP HOURS B</p>               |
| Engine PTO Hours              | <p>This display will provide a record of the Engine PTO hours sent from engine.</p> <p><b>Display Format:</b></p> <p>100,000.0<br/>ENG PTO HOURS</p>  |

## Controls/Features

---

| <b>Quadrant 1 – Display Messages</b> | <b>Description</b>  |
|--------------------------------------|---|
| Engine PTO Trip Hours                | <p>This display will provide a record of the Engine PTO Trip hours sent from engine.</p> <p><b>Display Format:</b></p> <p>100,000.0<br/>ENG PTO TRP HOURS</p>   |
| Instantaneous Fuel Economy           | <p>This display provides a record of the instantaneous fuel economy sent from the engine.</p> <p>The display shall be in miles per gallon or liters per 100 kilometers, corresponding to the units selected while in the odometer mode.</p> <p><b>Display Format:</b></p> <p>30.0<br/>INST MPG<br/>INST L/100KM</p>               |
| Trip Average Fuel Economy            | <p>The display value shall be the average fuel economy value since the last reset of the trip odometer.</p> <p>The display shall be in miles per gallon or liters per 100 kilometers, corresponding to the units selected while in the odometer mode.</p> <p><b>Display Format:</b></p> <p>30.0<br/>TRIP MPG<br/>TRIP L/100KM</p> |

| Quadrant 1 – Display Messages      | Description   |
|------------------------------------|---|
| Machine PTO Fuel Used A and B      | <p>The display value shall be the calculated Machine PTO Fuel Used.</p> <p><b>Display Format:</b></p> <p>100,000.0<br/>           PTO GAL A<br/>           PTO GAL B<br/>           PTO L A<br/>           PTO L B</p>                      |
| Machine PTO Trip Fuel Used A and B | <p>The display value shall be the calculated Machine PTO Trip Fuel Used.</p> <p><b>Display Format:</b></p> <p>100,000.0<br/>           PTO TRP GAL A<br/>           PTO TRP GAL B<br/>           PTO TRP L A<br/>           PTO TRP L B</p> |
| Engine PTO Fuel Used               | <p>The display value shall be the calculated Engine PTO Fuel Used.</p> <p><b>Display Format:</b></p> <p>100,000.0<br/>           ENG PTO GAL<br/>           PTO TRP L</p>   |

## Controls/Features

---

| Quadrant 1 – Display Messages | Description   |
|-------------------------------|---|
| Engine PTO Trip Fuel Used     | <p>The display value shall be the calculated Engine PTO Trip Fuel Used.</p> <p><b>Display Format:</b></p> <p>100,000.0<br/>ENG PTO TRP GAL<br/>ENG PTO TRP L</p>  |
| Trip Idle Fuel Used           | <p>The display value shall be the calculated Trip Idle Fuel Used.</p> <p><b>Display Format:</b></p> <p>100,000.0<br/>TRP IDL GAL<br/>TRP IDL L</p>  |
| Axle Load Indication          | <p>The instrument panel gauge cluster shall display an approximate value of Axle Load for the front and/or rear axles.</p> <p><b>NOTE:</b> Axle load readings are most accurate on a level surface with parking brake released.</p> <p><b>Display Format:</b></p> <p>approx. 45.0<br/>FT LBSX1000<br/>FT KGX1000<br/>RR LBSX1000<br/>RR KGX1000</p> |

| Quadrant 1 – Display Messages          | Description  |
|--|--|
| <p>Diesel Particulate Filter Level</p> | <p>The instrument panel gauge cluster shall display the relative Diesel Particulate Filter (DPF) Level.</p> <p>The instrument panel gauge cluster displays the following graph:</p> <div data-bbox="973 292 1445 413" style="text-align: center;"> </div> <p>With “L” (low) on the left and “H” (high) on the right, the graph is shown by bars each representing a 10 percent increase/decrease in soot level.</p> <p>The instrument panel gauge cluster displays the last received level until a new value is received, or until the instrument panel gauge cluster detects that it has not received a response to the SPN request, in which case it shall display the word “data n/a” within the bar graph.</p> |

**Quadrant 2: Text and Warning Messages**

These messages inform the driver of vehicle conditions. If the message flashes, it will flash for 3 – 5 seconds, and then will be displayed for an additional 3 – 5 seconds. If more than one message is viewable, the displayed message will be followed by

an asterisk “\*”, indicating multiple messages. To view additional messages, press and release the Display Control button to proceed to the next message.

The following is a list of the **routine** Text and Warning messages that can be displayed:

## Controls/Features

| Quadrant 2 – Display Messages | Description   | Flash (Yes/No) | Warning Indicator Association |
|-------------------------------|---|----------------|-------------------------------|
| Parkd Regen Active            | Message is displayed during a parked regeneration.  | No             | No                            |
| Load Shedding                 | Message is displayed when electrical load control and shedding feature is implemented.  | Yes            | No                            |
| Washer Fluid Low              | Indicates low washer fluid level.   | Yes            | No                            |
| Electrical Fault              | When instrument panel gauge cluster's ability to display diagnostic codes is enabled, this message is displayed when there are active diagnostic codes. | Yes            | No                            |
| Check A/C                     | Indicates a fault in the HVAC System.   | Yes            | No                            |
| Parkd Regen Inhibited         | Message is displayed when parked regeneration has been requested, but is not performed due to a vehicle interlock or an engine fault.                   | No             | No                            |
| Air Filter Restriction        | Message displayed indicates restricted air flow to the engine.  | Yes            | No                            |
| Exterior Lamp Check Active    | Message displayed indicates Exterior Lamp Check is in progress.   | Yes            | No                            |
| HVAC Temp Setting             | Bar graph displayed show temperature setting in low to high increments.   | No             | No                            |
| Activate HVAC Front Blower    | Bar graph displayed show blower speed setting in Off and low to high increments.  | No             | No                            |



| Quadrant 2 – Display Messages | Description  | Flash (Yes/No) | Warning Indicator Association |
|-------------------------------|--|----------------|-------------------------------|
| HVAC Sleeper Blower Speed     | Bar graph displayed show blower speed setting in Off and low to high increments.     | No             | No                            |
| Air Pressure Diagnostic       |  | Yes            | No                            |
| Cruise                        | Indicates that the Cruise Control System is turned On.                               | No             | No                            |
| Fuel Filter                   | Indicates that the fuel filter is clogged.   | Yes            | No                            |
| Check Brake Switch            |  | Yes            | No                            |
| Check Exterior Lamps          |  | Yes            | No                            |
| Engine Control Shutdown       |  | Yes            | No                            |
| Check Trailer Lights          |  | Yes            | No                            |
| Engine Control System Error   |  | Yes            | No                            |
| Parkd Regen Required          | Indicates parked regeneration is necessary.  | No             | No                            |
| Parkd Regen Inhibited Eng Tmp | Message is displayed when engine coolant temperature is below 170° F (76.6°C).       | No             | No                            |
| Regen Inhibit Switch Active   | Message is displayed when Regen Inhibit Switch is “On” and regeneration is disabled. | No             | No                            |
| Parkd Regen Available         |  | No             | No                            |
| Low Coolant Level             | Message is displayed when coolant level is less than or equal to 80%.                | Yes            | No                            |
| Stop Engine                   | Message is displayed when Red Stop indicator is illuminated.                         | Yes            | Red warning indicator         |

## Controls/Features

| Quadrant 2 – Display Messages      | Description  | Flash (Yes/No) | Warning Indicator Association                                 |
|------------------------------------|--|----------------|---|
| Warn Engine (Priority 1 or 2)      | (1) Message is displayed when MaxxFORCE® 11, 13, or 15 ECM turn on the Red warning indicator.<br><br>(2) Message is displayed when MaxxFORCE® 11, 13, or 15 ECM requests the Yellow warning indicator and not the Red warning indicator. | Yes            | (1) Red warning indicator<br><br>(2) Yellow warning indicator |
| Stop Hybrid                        | Message is displayed when Hybrid system turns on and requests the Red warning indicator.   | Yes            | Red warning indicator   |
| HV Batt Off-Line                   | Message is displayed when Hybrid system battery is off line.   | Yes            | No  |
| Check Hybrid                       | Message is displayed when Hybrid system turns on the Yellow warning indicator while conditions for “HV Batt Off-Line” message are not met.   | Yes            | Yellow warning indicator                                      |
| Low Engine Oil Level               | Message is displayed when engine oil level is less than or equal to 80%.   | Yes            | No  |
| Change Engine Oil                  | Message is displayed when engine oil change is detected as necessary.  | Yes            | No  |
| Water in Fuel                      | *Message is displayed when water in fuel is present.   | Yes            | No  |
| Refuel                             | Message is displayed when fuel level is low. MaxxFORCE® 11, 13, or 15 engines only.  | Yes            | No  |
| High Fuel Temp                     | Message is displayed when fuel temp is high. MaxxFORCE® 11, 13, or 15 engines only.  | Yes            | No  |
| Electrical Fault (Priority 1 or 2) | (1) Message is displayed when when EGC requests the Red warning indicator.<br><br>(2) Message is displayed when when EGC requests the Yellow warning indicator.  | Yes            | (1) Red warning indicator<br><br>(2) Yellow warning indicator |

| Quadrant 2 – Display Messages | Description   | Flash (Yes/No) | Warning Indicator Association |
|-------------------------------|---|----------------|-------------------------------|
| Check Trans                   | Message is displayed when transmission needs to be serviced.  | Yes            | Yellow warning indicator      |
| Trans Temp                    | Message is displayed when transmission turns on the Yellow warning indicator. Not available with all transmissions.   | Yes            | Yellow warning indicator      |
| Gen Trns Flt                  | Message is displayed when transmission turns on Red Stop, MIL, or PROTECT, or the Yellow Warning indicator without the conditions to display Check Trans, Trans Temp, Trans Oil Life, Trans Oil Filter, or Trans Service. Not available with all transmissions. | Yes            | Yes (see description)         |
| Trans Oil Life                | Message is displayed when transmission oil needs changed. Not available with all transmissions.   | Yes            | No                            |
| Trans Oil Filter              | Message is displayed when transmission oil needs changed. Not available with all transmissions.   | Yes            | No                            |
| Trans Service                 | Message is displayed when transmission needs service. Not available with all transmissions.   | Yes            | No                            |
| DPF Ash Service Required      | Message is displayed when diesel particulate filter ash level requires service/cleaning.  | Yes            | No                            |
| See Visor For Info            | Message is displayed indicates the particulate trap indicator must be on or must flash.   | Yes            | Yes (see description)         |

## Controls/Features

| Quadrant 2 – Display Messages   | Description   | Flash (Yes/No) | Warning Indicator Association |
|---|---|----------------|-------------------------------|
| ECM, TCM, Shift Selector, ABS, Retarder – Driveline, EGC, Compass Module, ESC, VSM, SD, AGSP, TPMS, Exhaust Module, Telematics, AGSP 2, SIC 2, AGSP 3, SIC 1, PAM, Hybrid, Service Tool, Global | Message is displayed when a module other than the engine requests the red stop warning indicator.   | Yes            | Red warning indicator         |
| ECM, TCM, Shift Selector, ABS, Retarder – Driveline, EGC, Compass Module, ESC, VSM, SD, AGSP, TPMS, Exhaust Module, Telematics, AGSP 2, SIC 2, AGSP 3, SIC 1, PAM, Hybrid, Service Tool, Global | Message is displayed when a module other than the engine requests the Yellow warning indicator.   | Yes            | Yellow warning indicator      |
| Retarder Temp   | Message is displayed when instrument panel gauge cluster receives signal from the Retarder – Driveline requesting the Yellow warning indicator.   | Yes            | Yellow warning indicator      |
| Gen Rtrd Flt  | Message is displayed when instrument panel gauge cluster receives signal from the Retarder – Driveline requesting the Red warning, MIL, or PROTECT indicator, or the Yellow warning indicator without the conditions to display Retarder Temp.. | Yes            | Yes (see description)         |
| DRV Reward Expected   |   | No             | No                            |
| DRV Reward Good   |   | No             | No                            |
| DRV Reward Excellent  |   | No             | No                            |
| DRV Reward Penalty  |   | No             | No                            |

| Quadrant 2 – Display Messages   | Description   | Flash (Yes/No) | Warning Indicator Association |
|---|---|----------------|-------------------------------|
| DRV Reward Increasing   |   | No             | No                            |
| DRV Reward Decreasing   |   | No             | No                            |
| VSL Ovrđ Active   |   | No             | No                            |
| VSL Ovrđ Expiring   |   | No             | No                            |
|   | Blank screen, available only when engine rpm less than or equal to 325 RPM, or vehicle speed less than 2 mph (3 km/h).                                    | No             | No                            |
| Calibrate Compass   | Message is displayed when vehicle speed is less than 2 mph (3 km/h) and the operator has not requested “Calibrate Compass” in the current ignition cycle. | No             | No                            |
| End Calibration   | Message is displayed when vehicle speed is less than 2 mph (3 km/h) and the operator has requested “Calibrate Compass” in the current ignition cycle.     | No             | No                            |
| Calibration Ended   | Message is displayed when vehicle speed is less than 2 mph (3 km/h) and the operator has requested “Calibrate Compass” in the current ignition cycle.     | No             | No                            |
| Declination Zone  | Message is displayed only when vehicle speed is less than 2 mph (3 km/h).   | No             | No                            |
| *If this message is displayed, drain water from fuel/water separator. |   |                |                               |

## Controls/Features

### Warning Messages

In addition to the Diagnostic Trouble Codes (DTC), the digital display will display a warning message whenever an Engine indicator is illuminated. This warning message will be toggled with the normal DTC as follows:

**Yellow Warning** indicator: WARN ENGINE message

**Red Stop** indicator: Stop Engine message

The following chart provides the warning messages that are displayed along with corresponding instrument panel gauge cluster indicators.

| MaxxForce® Engine |                 |
|-------------------|-----------------|
| Warning Indicator | Warning Message |
| Red Stop          | Stop Engine     |
| Yellow Warning    | Warn Engine     |

### Quadrant 3: Display Messages

#### Outside Temperature and Compass Displays (Optional)

The optional Outside Temperature and Compass Heading is displayed in Quadrant 3. Typical displays for Temperature and Compass Heading are listed in the following table. The display provides both the outside ambient temperature and the relative direction of the vehicle within a particular geographical zone.

Vehicle must be moving to acquire an accurate temperature.



| Quadrant 3 – Display Messages           | Description   |
|---|---|
| Outside Temperature and Compass Heading | <p><b>Display Format:</b></p> <p>32°F<br/>SE</p> <p>0°C<br/>SE</p> <p>32°F<br/>NO CAL</p> |

#### Outside Temperature Reading

The Outside Temperature is displayed on the first line of Quadrant 3 above the Compass Heading. The temperature sensor is located near the front bumper. Due to its location, the sensor readings can be affected by road or engine heat during idling or prevailing driving conditions (extended slow movement).

The display will be in °F or °C, depending on the units selected while in the odometer mode.

**Quadrant 4: Transmission Gear Displays**

| Quadrant 4 – Transmission Gear Indications |   |
|--|---|
| Allison P-R-N-D-L gear display             |  |
| Eaton Transmission display                 |  |

**Switches**

Six switches are located on the lower left and right side of the instrument panel gauge cluster. Configurations are optional. Blank cover plates will be used in spaces that do not have switches installed at those locations.

*Headlights*

The headlights will be at 100% brightness with the headlight switch activated. The park lights, tail lights, markers, and clearance lights will be on as well. An alarm will sound if the headlight switch is on and the ignition switch is off.

Your vehicle may be equipped with an optional headlight warning alarm that sounds immediately after ignition switch is turned to OFF position, when headlight switch is on, and the driver's door

is closed. It also sounds when headlight switch is on, ignition switch is in OFF position, and the drivers door is open.

The headlights are operated in a variety of modes:

*Daytime Running Lights (DRL)*

The Daytime Running Lights feature provides for low beam headlights at 75% brightness whenever the Parking Brake is released and the ignition switch is in the ON position. The lights will stay on until the Parking Brake is engaged.

*Lights On With Wipers*

This feature allows the headlights (low beam) to be automatically turned on when the windshield wipers are in steady or intermittent mode (not washer). The low beams will remain on until the ignition switch is turned to the OFF position or the headlights are cycled on and then off.

*Park Lights*

The park lights, tail lights, markers, and clearance lights will turn on when the headlight switch is in the park or headlight position.

*Panel Lighting*

The panel lighting brightness is controlled by the PANEL rocker switch. To increase the brightness of the instrument panel gauge cluster lighting, continually press the upper portion of the rocker switch. To dim the instrument panel gauge cluster lighting, continually press the lower portion of the rocker switch.



## Controls/Features





### Dome Lighting

The overhead dome light is used for reading and for illumination when entering and exiting the vehicle. The dome light on/off is also controlled by pushing on the lamp lens. When either entrance door is closed, the courtesy light will remain ON for approximately 20 seconds or until the ignition switch is turned ON. At that time, the lights will dim gradually until the light is off. The Optional keyless entry key fob also turns on the light for a time period when the Unlock button is pressed, and turns off the light (dims gradually to off) when the Lock button is pressed.

### Courtesy Lights

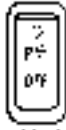
Either the driver or the passenger door activates the door-mounted courtesy lights to add light when getting in or out of the truck.

| Item No. | Item  | Description   |
|----------|---|---|
| 49       |  | Enables Auto Headlights in vehicles equipped with this feature. |
| 50       |  | Used to turn work lights on and off.                            |

|    |   |   |
|----|---|---|
| 51 |  | <p>Headlight/Park Lamp Switch</p> <p>Activates the headlight or parking lights, and illuminates the instrument panel gauge cluster. This switch functions even when ignition switch is turned off (a warning will sound when this switch is ON and the ignition switch is OFF).</p> |
| 52 |  | <p>Panel Dimmer</p> <p>Adjusts the panel lights brightness.</p>   |
| 53 |  | Used to turn cab dome light on and off and make it possible to activate/deactivate the dome light when opening the doors.   |
| 54 |  | Used to either turn on the sleeper dome or floor light.   |



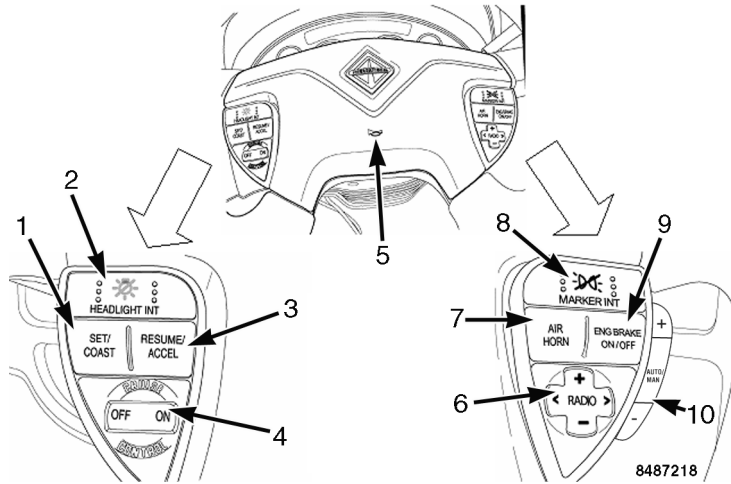

### Steering Wheel Controls



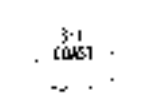
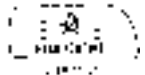

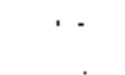
The steering wheel contains a variety of push-button switches to aid in the operation of the vehicle.

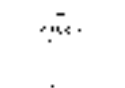
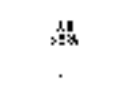
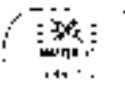
|   |   |  |
|---|---|--|
| 1 |   | SET/COAST - Used to set the speed desired on the cruise control or coast to a lower desired speed. When parked, used to decrease idle RPM. |
| 2 |  | HEADLIGHT INT - Used to momentarily turn off (interrupt) the headlights when pressed.  |

|   |   |   |
|---|---|---|
| 3 |  | RESUME/ACCEL - Used to resume the desired speed set on the cruise control or accelerate to a higher desired speed. When parked, used to increase idle RPM.  |
| 4 |  | OFF/ON - Used to turn the cruise control ON and OFF.  |
| 5 |  | HORN - Used to activate the city horn.  |
| 6 |  | RADIO (Optional) - Adjusts radio volume (+/-) and station selection (< >) with the radio turned on.   |
| 7 |  | AIR HORN - Used to activate the air horn.   |
| 8 |  | MARKER INT - Used to toggle the park lights and markers on or off, depending on park light switch position. If the park lights are on, it will toggle them off. If the park lights are off, it will toggle them on. |

## Controls/Features

|    |   |   |
|----|---|---|
| 9  |  | ENG BRAKE ON/OFF (Optional) - Used to turn engine brake on or off.                                |
| 10 |  | AUTO/MAN +/- (Optional) - Allows driver to select higher or lower gear of automatic transmission. |

### Cruise Control



**Do not use the cruise control system when unpredictable driving conditions are present. Such conditions include heavy traffic, roads that are winding, icy, snow covered, slippery, or with a loose surface. These conditions may cause wheel slippage and loss of vehicle control, resulting in property damage, personal injury, or death.**

- Press the ON position of the ON/OFF steering wheel control.
- Bring the vehicle to the desired operating speed (above 35 MPH), and push the SET/COAST position of the steering wheel control.
- Once in the cruise mode, the RESUME/ACCEL switch can be used to increase or decrease vehicle speed by pressing and holding the RESUME/ACCEL to increase the speed, or by pressing and holding the SET/COAST to decrease vehicle speed.

- A slight tap on the brake or clutch pedal will deactivate the cruise but hold the selected speed in memory. To return to the predetermined speed, press the RESUME/ACCEL switch.
- When you press the OFF position of the ON/OFF switch, or if the vehicle is shut off, the selected speed setting is canceled and removed from memory.

### Steering Column and Switches



The steering column contains switches and levers to aid in the comfort of the operator and to assist the operator while driving the vehicle.

1. **Tilting and Telescoping Adjustment Lever** - Allows the steering wheel placement to be adjusted for driver comfort. Push down to adjust, pull up to lock.

2. **Hazard Warning Switch** - Red rocker switch located above multipurpose turn signal lever. Push switch to forward position to activate. The hazard warning flasher will operate with the ignition switch in the ON or OFF position. Use the warning system any time your vehicle becomes a traffic hazard, day or night. Push switch rearward to deactivate.

**Stop Override Hazard (Optional)** - When hazard lights are activated and the brake pedal is depressed, all hazard/turn signal lights on the front, side lights of the truck, and the side trailer lights will continue to flash. The rear lights of the truck or tractor will burn steadily until the brake is released.

3. **Trailer Brake Lever** - This lever is used to apply and release the brakes to the trailer.

**Multi-function Switch** - The multi-function turn signal switch is mounted on the left side of the steering column below the steering wheel.

4. **Signaling For A Turn** - When signaling your intention to make a turn, move the turn signal lever up or down to the “full turn” position which is past the point of resistance. The switch does not automatically cancel and will require manual cancellation.

**Lane Change** – The turn signal lever includes a “lane change” feature which allows the operator to signal the intention to change lanes without locking the switch into the full turn position. To use this feature, move turn signal lever up or down to the point where resistance to movement is felt. The turn signal lever will return to the off position when released.

5. **Windshield Wiper** - The electric wiper has two speeds (hi-low), which can be operated by rotating the WASHER/WIPER knob. The optional intermittent control provides five wiper on/off cycle intervals, varying from 2 to 14 seconds. This is done by rotating the wiper control from the wiper OFF position to the any of the five intermittent wiper interval positions.

**Automatic Intermittent Interval Control (Optional)** – This feature automatically changes the wiper speed from HIGH or LOW to the slowest intermittent speed when the parking brake has been set, and the wipers have been on for a predetermined length of time. When the parking brake is released, the wipers return to their previous speed.



**Do not use the washers in freezing weather without first warming the windshield with the defrosters; otherwise, the washer solution may freeze on the windshield and obscure your vision and cause an accident which could result in property damage, personal injury, or death.**

**Do not use radiator coolant or antifreeze in the windshield washer reservoir. Radiator coolant in the washer reservoir can severely reduce visibility when sprayed on the windshield.**

Keep the fluid reservoir filled with Fleetrite Windshield Washer Solvent or equivalent.

6. **Low/High Beam** - When the turn signal stalk is pulled past the “click” position, lights will switch to Hi-Beam position. When pulled again they will revert to Lo-Beam.

**Headlight Flash-To-Pass** - When the turn signal lever is pulled with the headlights OFF, the Hi-Beam lights will come on and stay on as long as the lever is held in the pulled position. When the Lo-Beam headlights are ON, the Hi-Beam lights can be made to flash if the lever is not lifted past the click or dimmer position. When the Hi-Beam headlights are ON, the Lo-Beam lights can be made to flash if the lever is not lifted past the click or dimmer position.

7. **Washer/Wiper Control** - The windshield washer, along with the windshield wipers, is controlled by the WASHER/WIPER knob on the turn signal switch lever. To operate the windshield washer, push in on the wiper knob to spray solution on the windshield. Wipers will start wiping and continue for two cycles.



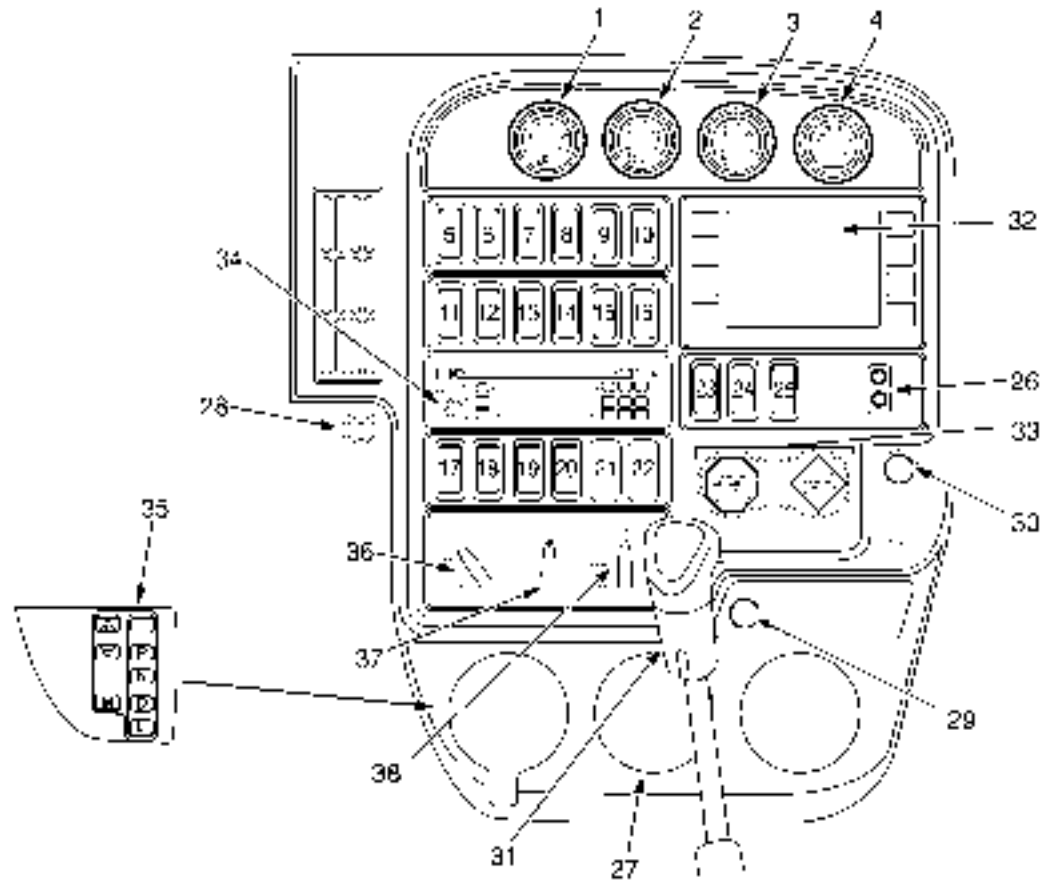

Center Dash Panel/Wing Panel



## Controls/Features





### Gauges



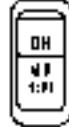

There are four optional gauges in the instrument panel gauge cluster of the center dash panel to help monitor the vehicle while in service.





| Item No. | Item   | Description   |
|----------|--|---|
| 1        |   | Provides reading of brake application air pressure in pounds per square inch (PSI).           |
| 2        |   | Provides monitoring of temperature of forward-rear axle lubricant in degrees Fahrenheit (°F). |
| 3        |   | Provides monitoring of temperature of rear-rear axle lubricant in degrees Fahrenheit (°F).    |
| 4        |  | Provides reading of turbocharger boost pressure in pounds per square inch (PSI).              |

### Switches



Up to 23 optional switches can be located in the center and lower right side of the center dash panel. Location of these switches will vary depending on the options installed. Blank cover plates will be used in spaces that do not have switches installed at those locations.

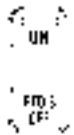

| Item No. | Item   | Description  |
|----------|--|--|
| 5        |   | MIR HEAT/ON<br>A momentary switch that, when pushed and released, turns the mirror heating element ON/OFF.           |
| 6        |   | SLPR TEMP<br>Controls the temperature in the sleeper compartment.  |
| 7        |   | SLPR FAN<br>Controls the on/off and fan speed of the temperature control in the sleeper compartment.                 |
| 8        |  | ENG BRAKE 1/2/3<br>A three position switch that selects the amount of engine braking (1 = Low, 2 = Medium, 3 = High) |

|    |   |  |
|----|---|--|
| 9  |  | <p><b>FOG LIGHT/ON</b></p> <p>Turns on Fog Lamps when headlight switch is on, and high beams are off.</p>  |
| 10 |  | <p><b>OFF ROAD (Bendix)</b></p> <p>This switch enables and disables the ABS traction control feature.</p> <p><b>MUD/SNOW (Wabco)</b></p> <p>This switch enables and disables the ABS traction control feature.</p> |
| 11 |  | <p><b>FAN OVRD/ON</b></p> <p>With the switch in the "ON" position, the engine fan mode is switched from auto to the constant on.</p>   |
| 12 |  | <p><b>PDL LOCK</b></p> <p>This switch is used to lock together the front and rear axle of a tandem for improved traction at low speeds on low-traction surfaces.</p>   |

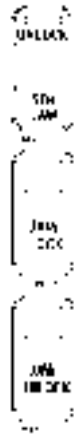

|    |  |  |
|----|--|--|
| 13 |   | <p><b>SUSP/DUMP</b></p> <p>This switch allows the operator to release the air from the air bags in a rear air suspension system when the vehicle's speed is less than 5 mph.</p> |
| 14 |   | <p><b>PTO OFF/ON</b></p> <p>Used when vehicle has single PTO option.</p> <p><b>PTO A OFF/ON</b></p> <p>Used when vehicle has dual PTO option.</p>                                |
| 15 |   | <p><b>PTO B OFF/ON</b></p> <p>Used when vehicle has dual PTO option.</p>   |
| 16 |  | <p><b>5TH WHEEL/SLIDE</b></p> <p>This momentary switch, when held on, releases the sliding 5th wheel (when ignition switch is in ON and vehicle speed is less than 2 mph).</p>   |

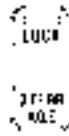
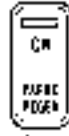
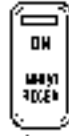
## Controls/Features

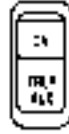
|    |   |   |
|----|---|---|
| 17 |  | <p><b>FIFTH WHEEL JAW UNLOCK</b></p> <p>Press and hold this momentary switch to unlock the fifth wheel jaw. Vehicle must be stationary, parking brake set, and ignition switch in the RUN position.</p> <p><b>5TH WHEEL JAW MONITORING LOCK/UNLOCK</b></p> <p>These switches activate an electronic jaw lock indicator system showing fifth wheel jaw status to the operator.</p> |
| 18 |  | <p><b>DIFF/LOCK</b></p> <p>Used when vehicle has single locking differential for improved traction on poor surfaces at low speeds.</p> <p><b>DIFF FR AXLE/LOCK</b></p> <p>Locks forward rear drive axle differential when vehicle has 6x4 independent locking differentials for improved traction on poor surfaces at low speeds.</p>   |

|    |  |   |
|----|--|---|
| 19 |   | <p><b>DIFF RR AXLE/LOCK</b></p> <p>Locks rear drive axle differential when vehicle has 6x4 independent locking differentials for improved traction on poor surfaces at low speeds.</p>        |
| 20 |   | <p><b>PARKD REGEN/ON</b></p> <p>DPF regeneration activation when parked switch is used for engine after-treatment. Manually initiates DPF regeneration.</p>                                   |
| 21 |   | <p><b>INHIBT REGEN/ON</b></p> <p>The Regeneration Inhibit switch is used to prevent the Normal Regeneration or Parked Regeneration processes.</p>   |
| 22 |   | <p><b>SLPR ENGINE CNTL</b></p> <p>Sleeper engine control switch is used when the vehicle has remote start. Allows the remote engine start/stop via a switch on the sleeper control panel.</p> |
| 23 |  | <p><b>TRLR AUX/ON</b></p> <p>Auxiliary trailer socket center pin control.</p>   |

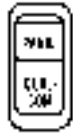

|    |   |   |
|----|---|---|
| 24 |    | <p>SPARE/ON</p> <p>Spare switch provided for customer usage of additional options.</p>  |
| 25 | <br><br><br><br> | <p>QUAL-COM/PANIC</p> <p>Sends distress signal.</p> <p>Used in conjunction with the (optional) Qualcomm satellite communication system – see Qualcomm System Owner's Manual.</p> <p>ENAB/DATA LOG</p> <p>When enabled, allows the driver to log the last five seconds of data group's operational parameter values into ECM memory.</p> |

- 26. Auxiliary Power Connectors
- 27. Cup Holder/Ashtray
- 28. Ignition
- 29. Cigarette Lighter
- 30. Accessory Power Outlet
- 31. Manual Transmission Shift Lever
- 32. Dash Vehicle Information Display (optional)
- 33. Air Brake Valve Controls
  - a. Trailer Air Supply
  - b. Parking Brake
- 34. Radio/Stereo
- 35. Automatic Transmission Push-Button Shifter (optional)

The center dash panel also consists of console components for driver comfort and use, as well as the transmission controls and Vehicle Information Display.

## Controls/Features

### Climate Control







Never drive the vehicle unless the windshield and all other windows are clear. A fogged, ice/snow covered, or dirty windshield or window limits vision, which could cause an accident, resulting in property damage, personal injury, or death. To improve defroster efficiency, remove ice and/or snow by hand from the windshield and windows with a non-metallic scraper.

#### CAUTION



To clear system of humid air, operate blowers for 30 seconds at high speed, with the AIR FLOW/AIR CONDITIONER knob on the normal heating position before selecting the DEF position. This will prevent fogging the glass, which can occur if humid air is blown onto a cool windshield.

**NOTE:** The vehicle may be equipped with heater shut off valve(s) to prevent hot coolant from circulating through the heater core(s). Closing the valve(s) during hot weather operation will improve A/C system performance. If the valves are shut off, in-cab temperature adjustment may become limited. In addition, when shut off valves are closed defrosters will only produce cold air.

| Item No. | Item                | Description  |
|----------|---------------------|--|
| 36       | Fan Speed Control   | Use this control to regulate the amount of air provided to the vents in any mode you select. Turn the knob clockwise to increase fan speed. Turning the control to the "OFF" position will shut off the fan, but does not prevent outside air from entering the vehicle. On vehicles equipped with A/C, moving the mode knob to the "MAX A/C" position will close the fresh air door eliminating outside air from entering the vehicle. Turning off the fan speed control also turns off the A/C compressor. |
| 37       | Temperature Control | Use this control to regulate the temperature of the air discharged from the vents. The blue area of the control indicates cooler temperatures while the red area indicates warmer temperatures.  |
| 38       | Mode Control        | <b>NOTE:</b> The dot between the mode control icons is an additional mix position between the two modes.<br><br>Use this control to direct the flow of air as follows:   |

|   |  |
|---|--|
|    | <p><b>MAX Air Conditioning Mode</b></p> <p>In this mode all airflow is directed to the panel air outlets and the air is recirculated inside the vehicle. Use this mode to block out any outside odors, smoke, or dust and to cool the interior rapidly upon initial start up in very hot or humid weather.</p> <p><b>NOTE:</b> Continuous use of the recirculate mode may make the inside air stuffy. Use of this mode for longer than fifteen minutes is not recommended.</p> <p>The A/C compressor turns on and off automatically as needed when in this mode.</p> |
|    | <p><b>NORM Air Conditioning Mode</b></p> <p>In this mode all airflow is directed to the panel air outlets. Fresh (outside) air is used to cool the vehicle in this mode.</p> <p>The A/C compressor turns on and off automatically as needed when in this mode.</p>   |
|    | <p><b>Bi-Level Air Conditioning Mode</b></p> <p>In this mode 75% of the airflow is directed to the panel air outlets and 25% of the airflow is directed to the floor air outlets, and fresh (outside) air is circulated inside the vehicle.</p> <p>The A/C compressor turns on and off automatically as needed when in this mode.</p>  |
|    | <p><b>Vent Mode</b></p> <p>In this mode all airflow is directed to the panel air outlets and fresh (outside) air is circulated inside the vehicle.</p>   |
|  | <p><b>Floor Mode</b></p> <p>In this mode all airflow is directed to the floor air outlets and fresh (outside) air is circulated inside the vehicle.</p>  |

## Controls/Features

|   |  |
|---|--|
|    | <p><b>Mix Mode</b></p> <p>In this mode 50% of the airflow is directed to the defrost and side demist air outlets and 50% of the airflow is directed to the floor air outlets, and fresh (outside) air is circulated inside the vehicle.</p> <p>The A/C compressor turns on and off automatically as needed when in this mode to reduce humidity levels and help reduce moisture buildup on the windshield.</p> |
|    | <p><b>Defrost</b></p> <p>In this mode all of the airflow is directed to the defrost and side demist air outlets and fresh (outside) air is circulated inside the vehicle.</p> <p>The A/C compressor turns on and off automatically as needed when in this mode to reduce humidity levels and help reduce moisture buildup on the windshield.</p>   |
| <p>To remove stale air or smoke while air conditioner is operating, you may want to open a vent window for a short period of time. Always park in the shade when possible. If your vehicle has been parked in the sun with the windows up, remove the overheated air inside by driving with windows down and the air conditioner ON for one or two city blocks.</p> |  |

### Air Conditioning

#### CAUTION

**Failure to follow recommended service procedures and maintain adequate air flow through air exchange devices may result in component failure. Cleaning should be performed by a qualified technician.**

Keep radiator area free of bugs, leaves etc. Do not cover the condenser with a wire screen.

At least once or twice a month turn on the air conditioner for a few minutes while the engine is running. This periodic operation keeps all the mechanical parts of your air conditioner in good operating condition.

It is normal for small amounts of water to drain out of the air conditioner module. This water is condensed moisture removed from the air inside the vehicle.

Correct airflow may be restored by either replacing the filter(s), which can be done without tools, or by cleaning the filters. The filter(s) may be cleaned by using a power washer with a soap solution. Keep the spray head at least six inches away from the filter to avoid damage. Rinse thoroughly.

**NOTE:** If your air conditioning performance seems lower than expected, check the front of the A/C condenser for an accumulation of dirt or insects. Clean with a gentle water spray from behind the radiator and through the condenser as required. Check for dirt and debris in both the cab and sleeper HVAC intake filters that may reduce airflow.

*Dehumidification*

The heater-defroster systems can be operated simultaneously with the air conditioner during mild weather and high humidity conditions to dehumidify the cab air. Turn the mode button to one of the A/C positions and position the temperature knob at a comfortable temperature location. The air conditioner will remove the humidity while the heater keeps the cab comfortable.

**Electronic Vehicle Monitoring**

**Base Display**



8487337

The optional Electronic Vehicle Monitoring Driver Information Display provides trouble code reporting, trip status, vehicle

and engine usage, fuel economy information, video inputs for external cameras and a USB port for loading MP3 audio files that can be played through the radio. This unit also provides an interface for the optional SmartWave® tire pressure management system and a port that is compatible with the optional Qualcomm Omnivision system. Refer to the Driver Information Display operator reference card, or visit <http://www.lectronix.biz/support.html> for additional information.

**Premium Display**

The optional Premium display is the same as the Base unit, but with an additional navigation feature. This feature provides mapping features, turn-by-turn directions, and truck points of interest.

**SmartWave® Display**



0487336

The optional SmartWave® tire alerts and warnings display has three automated tire alerts to instantly warn the driver of an underinflated tire before it becomes dangerous; pressure

## Controls/Features

---

deviation alert, critical low pressure alert, and high temperature alert. Refer to <http://www.smartire.com/support/manuals> for complete owner's manual.

### Door and Window Controls

#### Door Lock/Unlock

##### *Cab Doors and Locks*

The cab door and sleeper luggage doors can be unlocked with the same key used for the ignition lock. There is also a keyless remote entry available.

**NOTE:** The vehicle is delivered with two identical keys. If more keys are needed, order them through your authorized International® Truck Dealer. Record the key code and keep it in a secure place. A new key can be made if the keys are lost.

With mechanical locks, only one door can be locked/unlocked at a time. Electrical locks can lock/unlock both doors by operating either the key, keyless entry fob, or the inner door lock handle on either side.

#### *Remote Keyless Entry Operation (Optional)*

**NOTE:** This device complies with Part 15 of the FCC Rules and with RSS-210 of Industry Canada. Operation is subject to the following two conditions:

1. This device may not cause harmful interference
2. This device must accept any interference received, including interference that may cause undesired operation.

Changes or modifications not expressly approved by the party responsible for compliance could void the user's authority to operate the equipment.



The remote keyless entry key fob is used to lock and unlock both cab doors from a distance of **30** feet. Click once to unlock the driver's door, click twice to unlock both cab doors. Whenever the doors are locked or unlocked using the key fob, the city horn sounds momentarily (chirps). Also, the optional keyless entry key fob turns on the interior light for a time period when its

Unlock button is pressed, and turns off the light (dims gradually to off) when its Lock button is pressed. The Panic (emergency) button, when pushed, causes the horn to chirp on/off for three minutes, in unison with the headlights and park lights flashing. This feature works only when the ignition switch is in the OFF position.

*Lock/Unlock From Interior*



**To help reduce the risk of personal injury in the event of an accident, keep doors locked when vehicle is in motion.**

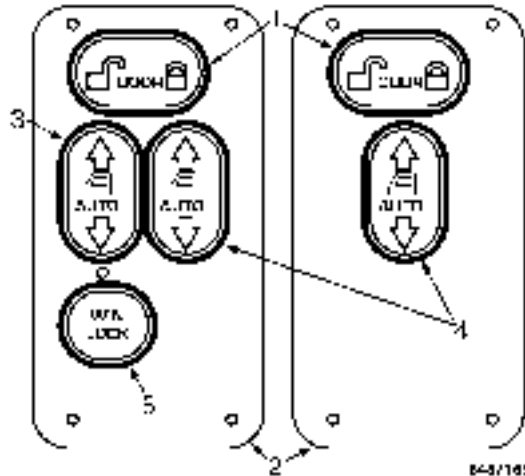

1. Lock/Unlock Button
2. Door Control Panel
3. Driver Side Power Window Control
4. Passenger Side Power Window Control
5. Window Lock Control

**Locking the Door**

To lock, push the lock/unlock button on the lock symbol in the door control panel located by the vent window. Pressing the lock/unlock button on the lock symbol once locks both cab doors.

**Unlocking the Door**

To unlock, push the lock/unlock button on the unlock symbol in the door control panel located by the vent window. Pressing the lock/unlock button once on the unlock symbol unlocks the driver door. Pressing it twice unlocks both doors.

*Automatic Door Lock Function*

The automatic lock function automatically locks the doors at a predetermined speed.

**Driver/Passenger Windows**

*Manual Operation*

To lower door glass (driver door), turn window regulator handle clockwise. To raise glass, turn handle counterclockwise. Reverse this procedure for the passenger door.

## Controls/Features

---

### *Power Operation*

Trucks may have optional electrically operated driver and passenger windows. Controls for these window lifts are mounted in the door control panels located by the vent windows. The driver side controls regulate window operation for both driver and passenger. To lower or raise driver window, press and hold either “Up” or “Down” direction on the driver side AUTO window control. To lower or raise passenger window, press and hold either “Up” or “Down” direction on the passenger side AUTO window control.

For one touch windows down operation, press and release the window control in the “Down” direction. The window will then go to the full down position automatically.

### *Window Lockout Function*

The driver also has the ability to prevent passenger window up/down operation by pressing the WINDOW LOCK control.

### *Mirror Controls*

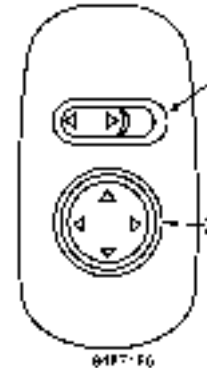

1. Mirror Select Switch
2. Mirror Direction Control Switch

These controls provides the driver with the ability to operate both driver and passenger-side flat mirrors. Use the mirror select switch to select which mirror is to be adjusted, and adjust the mirror using the mirror direction control switch.

### *Vent Window*

Vehicles are equipped with either a fixed or opening vent window. The opening vent window can be opened and closed to allow additional air flow into the cab.



## Eaton VORAD Collision Warning System (Optional)



Before using this feature, read and thoroughly understand the Eaton VORAD Collision Warning Systems Driver Instructions manual, and obtain proper training on the system. Improper use of this system could result in property damage, personal injury, or death.



The Eaton VORAD Collision Warning System is intended solely as an aid for an alert and conscientious professional driver. It is not to be used or relied upon to operate a vehicle. The system should be used in conjunction with rear view mirrors and other instrumentation to maintain safe operation. A vehicle equipped with the Vorad Collision Warning System should be operated in the same safe manner as if the Vorad Collision Warning System were not installed. The system is not a substitute for normal safe driving procedures. It will not compensate for any driver impairment, such as drugs, alcohol, or fatigue. Failure to heed this warning may result in property damage, personal injury, or death.



The Eaton VORAD Collision Warning System may provide little or no warning for some hazards, such as pedestrians, animals, oncoming vehicles, and cross traffic. Failure to heed this warning could result in property damage, personal injury, or death.

### System Description

The Eaton VORAD system uses forward-looking radar and optional side-looking radar to constantly monitor vehicles ahead and in the blind spot area, respectively. The Vorad Collision Warning System determines the distance and relative speed of the object in front of the vehicle to warn the driver of potentially dangerous situations through visual and audible alerts. The **SmartCruise®** feature works with the vehicle's cruise control system to attempt to automatically maintain a fixed following distance between the host vehicle and a vehicle ahead. The Side Object Detection system can detect moving or stationary objects in the lane next to the vehicle and alert the driver of their presence.

Visual and audible alerts are provided by the Driver Interface Unit located in the dash panel where it is easily visible and accessible. Refer to the Driver Instruction manual for complete operating instructions.

### Driver Reward

The driver reward feature is designed to give the operator programmable incentives for driving more efficiently. This

## Controls/Features

---

is accomplished by measuring the driver's habits based on fuel economy, time at idle, or both. Rewards include higher maximum vehicle speed and higher cruise control speed limit. Lower maximum vehicle speed or cruise control speed limits may result as a penalty for failing to meet the standards.

The following driver reward visual indications appear in the form of text messages in the gauge cluster digital display:

- Expected – Reward indication which results in higher vehicle speed limits.
- Good – Reward indication which results in higher vehicle speed limits.
- Excellent – Reward indication which results in higher vehicle speed limits.
- Penalty – Penalty indication which results in lower vehicle speed limits.
- Increasing – Informs the driver that the vehicle speed limit will soon be increased.
- Decreasing – Informs the driver that the vehicle speed limit will soon be decreased.

## SECTION 5 — SLEEPER FEATURES

### Introduction

#### General Information

There are three trim versions of sleepers available, the ProStar®+ Series, the ProStar®+ Eagle Series, and the ProStar®+ Eagle Series Suite. The International® ProStar®+ Series sleeper compartment comes in two sizes, 56-inch (142 cm) (short) sleepers and 73-inch (185 cm) (long) sleepers.

#### Main Features

The sleeper compartments are designed to accommodate different needs and your sleeper may or may not be equipped with all the features listed in this section.

1. Duct Work Vents
2. Rear Wardrobe Cabinet
3. Airline Cabinets
4. Speakers
5. Control Panel
6. Cup Holders and Storage Trays
7. Lower Bunk
8. Under Bunk Storage Area

Common features on the International® ProStar®+ Series 56-inch (142 cm) (short) sleeper model.

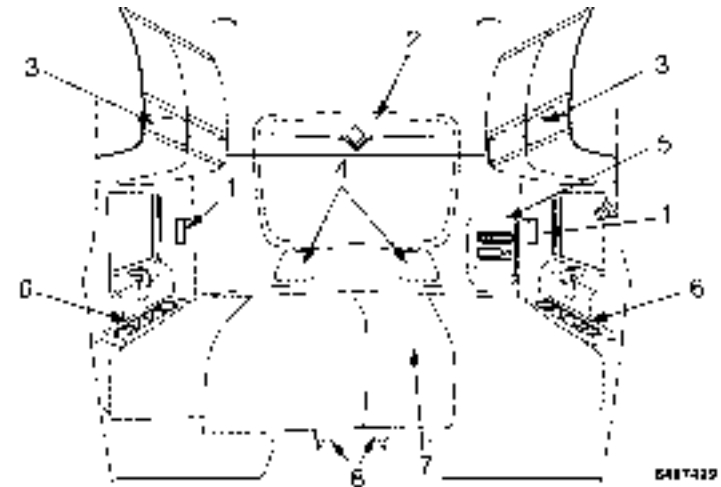

## Sleeper Features

Common features on the International® ProStar®+ Series 73-inch (185 cm) (long) sleeper model with lower bunk.

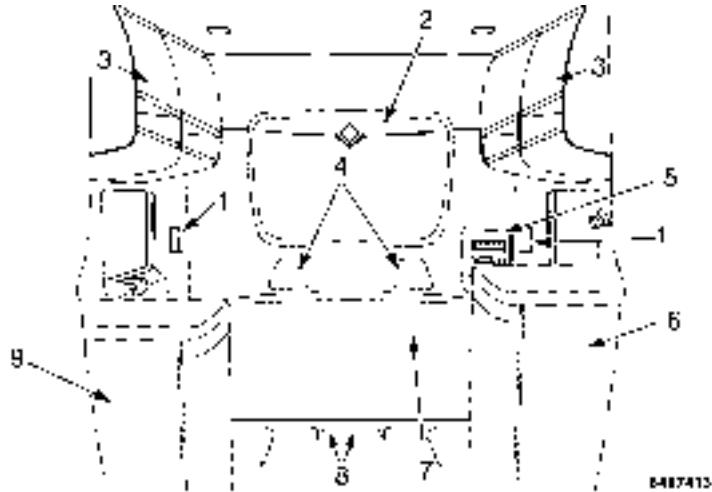

1. Duct Work Vents
2. Rear Wardrobe Cabinet
3. Airline Cabinets
4. Speakers
5. Control Panel
6. Tower Cabinet

Common features on the International® ProStar®+ Series 73-inch (185 cm) (long) sleeper model with lower and upper bunks.

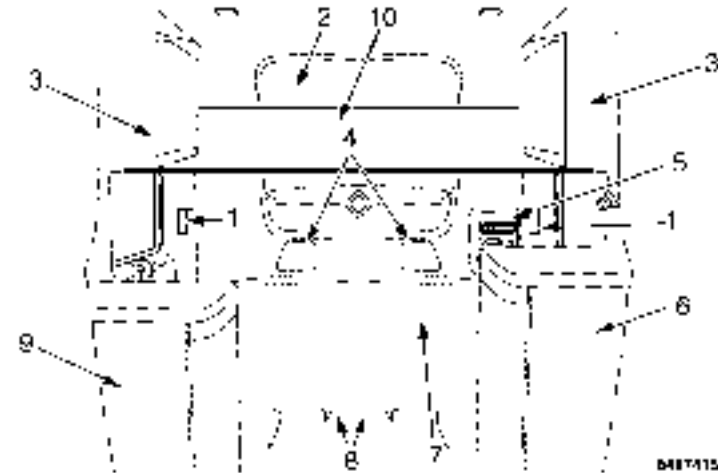

7. Lower Bunk
8. Under Bunk Storage Area
9. Refrigerator Cabinet or Dresser Cabinet
10. Upper Bunk

**NOTE:** Although not illustrated, the long sleeper models are equipped with the same cup holders and storage trays (both ends of lower bunk) as illustrated for the short sleeper model.

### Lighting

#### Dome Light

The sleeper dome light is a large fluorescent light located on the headliner of the sleeper compartment. The sleeper dome light can be controlled by switches located on the sleeper control panel and on the dash instrument panel. This two-switch arrangement permits the driver to turn the sleeper dome light on or off before entering the sleeper area and turn the sleeper dome light on or off without having to go back to the cab area.

#### Reading Lights

The bunk reading light is positioned on the side panel, left side, to provide illumination for easy reading. If the sleeper compartment is equipped with the upper bunk option, a second reading light is provided at the head of the upper bunk. Depressing the switch on the housing will turn the reading light on and off.

#### Floor Lights

There are two red floor lights located under the lower bunk included with all sleeper cabs. These floor lights are controlled by the same two-switch arrangement as the sleeper dome light.

#### Accent Lights

Convenient accent lights are located on the sleeper compartment headliner and provide an additional level of illumination within the sleeper compartment. There are four accent lights in the long sleeper and two accent lights in the short sleeper. Two switches are located on the sleeper control panel for controlling the accent lights.

- **Accent Light Dimmer Switch:** Used for adjusting the brightness of the sleeper compartments accent lights.
- **Accent Light Switch:** Used for turning the accent lights on and off.

## Sleeper Features

### Sleeper Control Panel

#### General Information

The sleeper control panel comes with several optional features but the main components are the switch pack, sleeper climate controls, and inverter control panel.

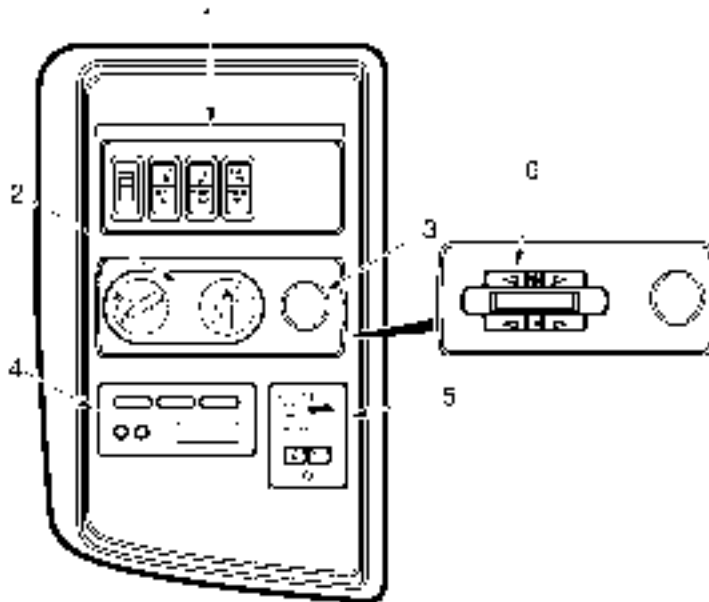

| Sleeper Control Panel |                        |   |
|-----------------------|------------------------|---|
| Item No.              | Component              | Description   |
| 1                     | Switch Pack            | The sleeper control panel is equipped with locations for up to six switches.  |
| 2                     | Climate Controls       | Manual heater, ventilation, and air conditioning (HVAC) Controls.   |
| 3                     | Power Receptacle       | Standard 12V power socket.  |
| 4                     | Radio Remote Control   | Can be used to control the functions of the dash mounted radio from the sleeper.  |
| 5                     | Inverter Control Panel | The inverter control panel is used for controlling the power inverter that allows the use of items such as a TV, VCR, microwave, hair dryer, etc. |
| 6                     | Climate Controls       | Optional LED electronic heater, ventilation, and air conditioning (HVAC) Controls.  |

## Accent Light Dimmer Switch

This switch is used for adjusting the brightness and dimness of the sleeper compartment accent lights.

- Up position brightens the accent lights.
- Down position dims the accent lights.



## Accent Light Switch

This two position switch operates the four accent lights located in the long sleeper ceiling or two accent lights located in the short sleeper ceiling.

- Press on the top of the switch to turn the accent lights on.
- Press the bottom of the switch to turn the accent lights off.



## Sleeper Dome/Floor Light Switch

This two-position switch operates the large fluorescent dome light located in the sleeper ceiling and the three red floor lights located under the lower bunk and the dash center panel.

- Press on the top of the switch to turn the dome light on or off.
- Press on the bottom of the switch to turn the floor lights on or off.



## Engine Control Switch



**Never start the engine unless you're sure the transmission selector is in neutral and the brake is applied, otherwise accidental movement of the vehicle can occur, which could result in property damage, personal injury, or death.**



**DO NOT crank the engine for more than 30 seconds at a time; wait two minutes after each try to allow the starter to cool. Failure to follow these instructions could cause starter damage.**

The ENGINE CNTL switch allows the operator to start the vehicle from the sleeper compartment.

**NOTE:** The ENGINE CNTL switch will only operate under the following conditions:

- Dash mounted SLPR ENGINE CNTL switch is ON
- Transmission is in neutral
- Parking brake is set
- Hood is closed
- Ignition switch in the ON position with the engine not running



## Sleeper Features

To start the engine from the sleeper, press and hold the top of the ENGINE CNTL switch. There will be a 15 second delay during which an audible engine start alarm will sound then the engine will begin cranking. Release the switch as soon as the engine starts.

To stop the engine, press the ENGINE CNTL switch again.

### Manual Climate Controls

**NOTE:** If sleeper air conditioning is desired and the main cab blower is not enabled, the air conditioner will not function and the message **Activate Front Blower** will appear on the instrument panel gauge cluster.

The manual climate controls allow the operator to adjust the temperature and amount of air circulated through the sleeper compartment.

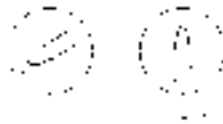

1. **Fan Control:** Turns the fan on and off, and controls the fan speeds.

**NOTE:** Fan speed will be limited to approximately 50% of maximum when the engine is not running.

2. **Temperature Control:** Use the temperature control to regulate the temperature of the air inside the sleeper compartment. This temperature is independent of the cab area. The blue area indicates cooler temperatures and the red area indicates warmer temperatures.

### Electronic Climate Controller

**NOTE:** If sleeper air conditioning is desired and the main cab blower is not enabled, the air conditioner will not function and the message **Activate Front Blower** will appear on the instrument panel gauge cluster.

The electronic climate controller provides easy adjustments of the sleepers heating and air conditioning system by using the buttons.

1. **Fan Control Buttons:** Pressing the left button repeatedly will lower the fan speed to minimum, then turn the fan OFF. Pressing the right button turns the fan ON (if currently off), then raises the fan speed to maximum.

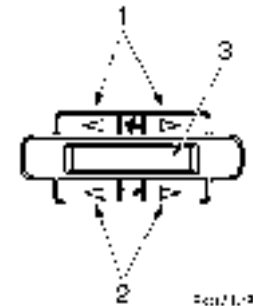

**NOTE:** Fan speed will be limited to approximately 50% of maximum when the engine is not running.

2. **Temperature Control Buttons:** Use these buttons to regulate the temperature of the air inside the sleeper compartment independent of the cab area. Press the left button to lower the temperature and the right button to raise the temperature.

3. **Display:** Allows the operator to view the settings for fan speed and air temperature as they are being adjusted.

**NOTE:** The temperature display is a representation of the current temperature set point, not actual sleeper temperature.



### Power Receptacle

A 12 Volt power socket is located to the right of the sleeper climate controls. This power source provides a location to operate accessories.



### Radio Remote Control

The radio remote control gives the operator the ability to operate the dash-mounted radio from the sleeper compartment. For more information on the radio remote control refer to the Radio Manual.

### Remote Power Inverter Panel

This optional feature allows the operator to control the power inverter (if equipped) from the sleeper compartment. The power inverter converts 12 Volt DC current to 120 Volt AC current for running the electrical features in the sleeper compartment.

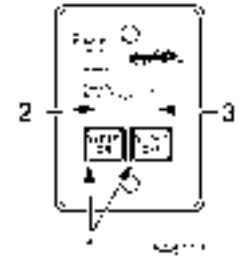

1. **ON/OFF Buttons:** Press the System ON button to turn the power inverter on and press the System OFF button to turn the power inverter off.
2. **Power Indicator Light:** The power inverter light will be illuminated green when the power inverter is powered on. A blinking green light indicates that the power inverter is in standby mode and the batteries are being charged.
3. **Fault Indicator Light:** This light is used to notify the operator that a fault exists with the power inverter. A solid red light indicates the power inverter is in Over Temperature/Overload/or Battery Low Mode. No light indicates that no fault exists.

For more information on the remote power inverter panel refer to the Power Inverter Manual.

# Sleeper Features

---

## Windows

### General Information

**CAUTION**

**Make sure windows are closed before washing the cab. Water can enter the cab through the window opening.**

1. Sleeper Window
2. Handle

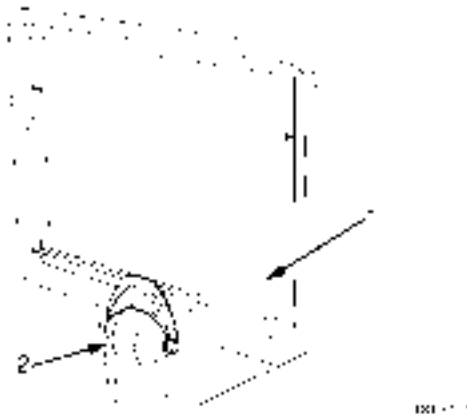

The sleeper compartment is equipped with a window on each side that can be opened for ventilation.

- Lift the handle to open the window.
- Lower the handle to close and lock the window.

Optional privacy curtains are provided to cover the sleeper windows. To install the curtains, place the curtain over the window and secure the curtain loops to the window frame. When not in use, store the curtains in one of the storage compartments.

### Bunk Restraint System

#### General Information



**Always use occupant restraint system when vehicle is moving. Any location in the vehicle not equipped with a seat belt, bunk restraint belts, or sleeper berth restraint webbing should not be occupied when the vehicle is being operated. In the event of a vehicle accident or sudden, unexpected movement, failure to properly use an occupant restraint system could result in personal injury or death.**

Two types of sleeper bunk occupant restraint systems are available with sleeper bunks supplied by Navistar, Inc. If the sleeper berth is not provided with one of these two types of restraint systems, that bunk is not intended to be occupied when the vehicle is in motion and must not be used when the vehicle is being operated. The description and recommended usage of the two available restraint systems for sleeper berth areas are as follows:

#### Adjustable Belts

This two-belt system is standard with the sleeper lower bunk. To use the adjustable belt system, the bunk occupant should place one belt across the lower body (positioned above the occupants knees but below the hips), and the other belt should be positioned across the upper body (above the hips but below the shoulders). Slack must be removed from belts after connecting the buckle by pulling the loose end of each belt to fit the connected belt snugly across the occupant's body.

#### Restraint Webbing System

The optional restraint webbing system is secured around the bunk with seven buckles. The only restraint system provided with the optional upper bunk is the restraint webbing system. To use the restraint webbing system follow these steps:

## Sleeper Features

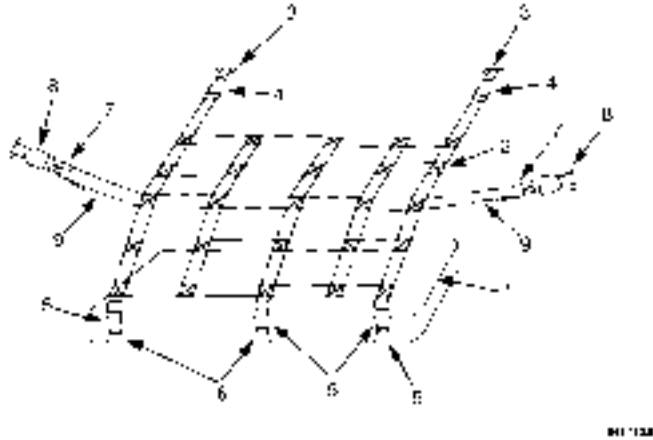

1. Bunk
2. Restraint Webbing System
3. Rear Latches
4. Rear Buckles
5. Font Latches
6. Front Buckles
7. Side Latch Plates
8. Side Buckles
9. Restraint Strap

To install the restraint webbing system onto the sleeper bunk:

1. Enter the bunk and lay the restraint webbing system out on top of your body.
2. Insert two rear latches on the rear wall into two mating buckles (4) that are sewn to the restraint webbing system, making sure that both buckles are fully latched.
3. Insert three front latches that are sewn to the front of the restraint webbing system into the front buckles mounted at the front of the bunk, making sure that all three front buckles are fully latched.
4. The restraint webbing system is designed to be held up away from the reclining bunk occupant by the adjustable side latch plates on each side of the restraint webbing system. Insert two side latch plates that are sewn to the restraint webbing system into the side mating buckles located on the sleeper compartment side walls.
5. To adjust the restraint webbing system, pull the short straps at the side latch plates on each side of the restraint webbing system to tighten. Loosen the restraint webbing system by raising the side latch plates away from the restraint strap to allow the restraint strap to loosen through the latch plates.
6. Removal of the restraint webbing system is done by loosening both side latch plates, unlatching the side latch plates, unlatching the three buckles at the front of the bunk, and unlatching the two buckles attached to the rear wall.

## Lower Bunk

### General Information

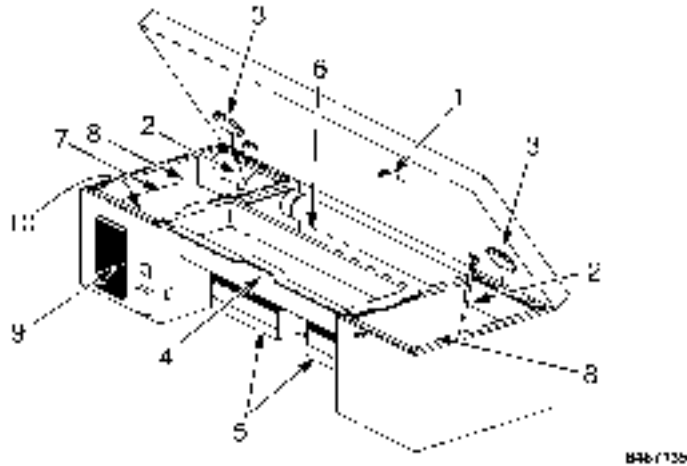

Upper and lower bunks are available in the International® ProStar®+ Series sleeper compartment. The lower bunk is standard while the upper bunk is an option. The lower bunk is hinged for access to the features under the bunk. Gas shocks aid in opening and closing of the lower bunk and hold the bunk in the raised position for access.

| Item No. | Component               | Description   |
|----------|-------------------------|---|
| 1        | Release Latch           | To open, press upward on the latch mechanism and lift the front edge of the bunk platform. To close, lower the bunk until the latch mechanism is locked in place.                       |
| 2        | Gas Shocks              | The lower bunk is fitted with two gas shocks to aid in opening, closing, and supporting the bunk in the opened position.  |
| 3        | Lights                  | The lower bunk has two automatic lights that turn on as the bunk is raised and turn off when the bunk is lowered. These lights also operate when the exterior luggage doors are opened. |
| 4        | Storage Tray            | A removable storage tray is located under the center of the bunk and can easily be removed from its location once the bunk is opened.   |
| 5        | Lock Boxes              | Two lock boxes are provided under the bunk storage tray for securing valuables out of site.   |
| 6        | Power Inverter          | The optional power inverter is stored under the bunk in the center compartment.   |
| 7        | Sleeper HVAC Components | The sleeper heating, ventilation, and air conditioning (HVAC) components are stored under the bunk.   |
| 8        | Luggage Compartment     | Access to the luggage compartments can be achieved from the interior with the lower bunk in the raised position.  |

## Sleeper Features

|    |                                |   |
|----|--------------------------------|---|
| 9  | Sleeper HVAC Intake            | Allows air to enter sleeper HVAC unit. Do not block HVAC air intake.  |
| 10 | Sleeper HVAC Air Intake Filter | Replaceable/cleanable filter cleans air and protects heat exchanger from becoming plugged with lint and debris. |

### Upper Bunk

#### General Information

The optional upper bunk is hinged and can be raised and locked out of the way. Brackets are located on each side wall to hold the bunk in the down position and a latch is located on the passenger side to hold the bunk or release it from its stowed position. Access to the upper bunk is provided by steps that are attached to the driver side tower cabinet.

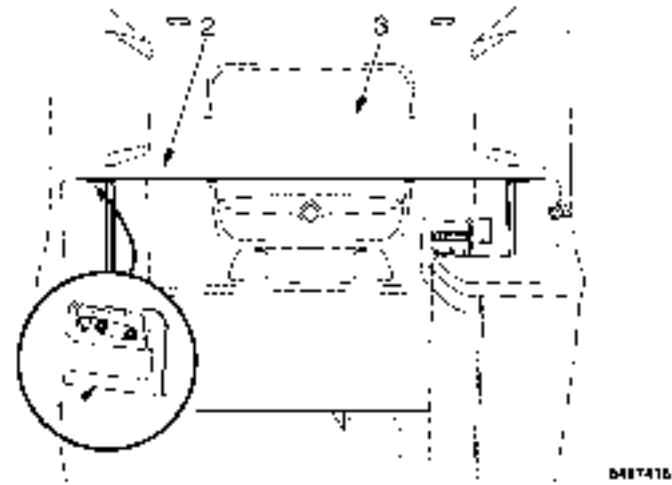

1. Release Latch
2. Upper Bunk Frame
3. Upper Bunk

**NOTE:** The sleeper compartment is equipped with a dome light to aid entry and exit into the upper bunk. The dome light on/off switches are located on the dash instrument panel and on the sleeper control panel.

### Entering The Upper Bunk

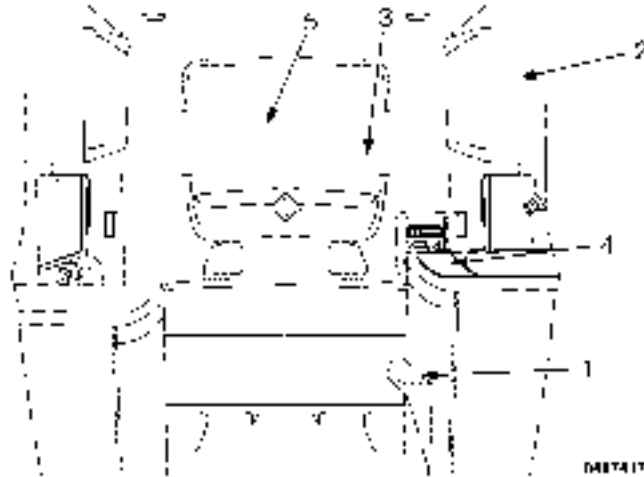

1. Bottom Step
2. Airline Cabinet
3. Front Bunk Rail
4. Top Step
5. Upper Bunk

1. Begin by facing the bottom step, placing your right foot on the bottom step, and grasp the front edge of the airline cabinet with your right hand and grasp the front bunk rail with your left hand (The bunk area is designed for your head to be at the driver's side of the bunk).
2. Step up on the bottom step and place your left foot on the top step while maintaining a firm grip on the front edge of the airline cabinet with your right hand and the front bunk rail with your left hand.
3. Release your right hand from the front edge of the airline cabinets and grasp the front bunk rail.
4. Step up on the top step with both feet and while keeping a firm grip with both hands on the front bunk rail, swing your right hip over onto the upper bunk.
5. Release your left hand from the front bunk rail and grip the front edge of the upper bunk, along side your left hip.
6. Swing your legs up and to the right, positioning your body in the center of the upper bunk.

## Sleeper Features

---

### Exiting The Upper Bunk

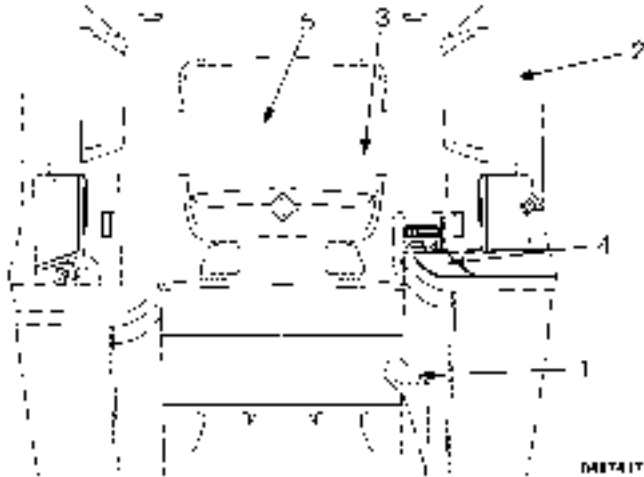

1. Bottom Step
2. Airline Cabinet
3. Front Bunk Rail
4. Top Step
5. Upper Bunk

1. While keeping a firm grip with both hands on the front edge of the upper bunk, sit up on the upper bunk positioning your body above the top step and your legs over the front of the upper bunk.
2. Grab the front bunk rail with your right hand and the front edge of the upper bunk with your left hand. Pivot your body to the left, swinging your left leg down, and placing your left foot on the top step (4). Release the front bunk rail with your right hand and grasp the front edge of the airline cabinet.
3. Grab the front bunk rail with your left hand and front edge of the airline cabinet with your right hand, and place your weight on the top step. Step down with your right foot to the bottom step.
4. Keeping a firm grip on the front bunk rail and the front edge of the airline cabinet, step down to the cab floor with your left foot followed by your right foot. You can now release the front bunk rail and front edge of the airline cabinet.



### Cabinets/Storage

#### General Information



**Always remove all loose items from the interior and store appropriately when vehicle is in motion. Falling items can be a distraction to the driver or a projectile during an accident which could result in personal injury or death.**

**NOTE:** The following will describe and illustrate the standard cabinets and their storage functions for the International® ProStar®+ Series long sleeper. Your vehicle may not have all of these features.

The sleeper compartment is designed to accommodate several different types of cabinet configurations to fit all needs.

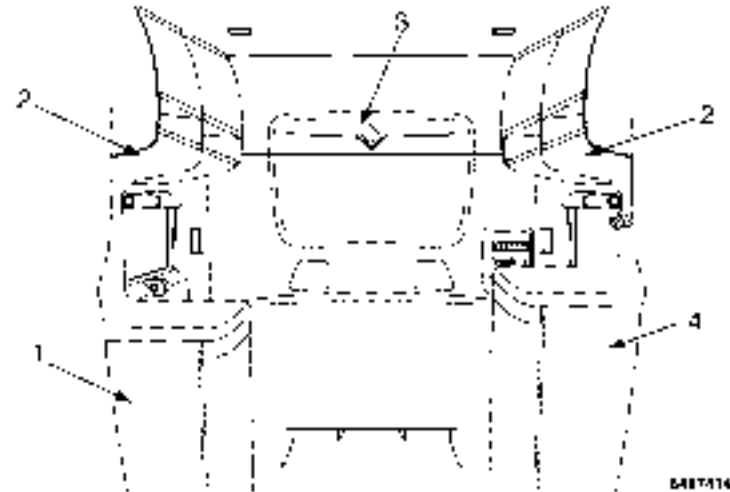

1. Optional Dresser Cabinet or Optional Refrigerator Cabinet
2. Airline Cabinets
3. Rear Wardrobe
4. Tower Wardrobe

## Sleeper Features

### Cabinets

#### Refrigerator Cabinet

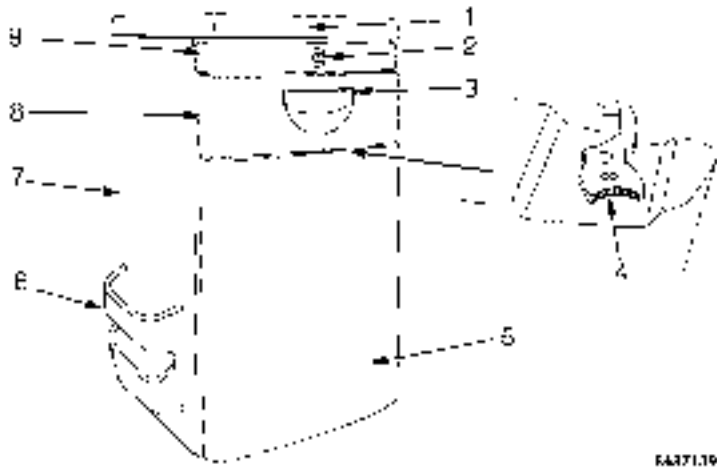

1. **Refrigerator Top:** The top of the refrigerator cabinet serves as a desk top.

2. **Release Knob:** A release knob is used to open the work table. To open, depress the knob, the knob will extend from the work table, then pull the work table open. To close the work table depress the tab, along the forward side of the work table, and slide the work table shut. Once the work table is closed the knob needs to be pressed in to a flush position with the work table (this prevents the knob from getting hung on your clothing and other items as you move around in the sleeper compartment).
3. **Lift Release Handle:** The drawer is equipped with a lift release handle. To open the drawer, lift the handle from the bottom and slide the drawer open. To close, push the drawer shut until the lift release handle locks the drawer shut.
4. **Door Lock:** The door lock prevents the door from opening while in motion. To unlock, push the door lock to the left. To lock the door, push the door lock to the right.
5. **Door:** The optional 1.7 cubic ft. refrigerator is equipped with an adjustable thermostat, internal light, shelf, and small freezer for making ice. The door provides an attractive look to the refrigerator cabinet and hides the refrigerator.
6. **Magazine Pocket:** Provides a storage area for books, magazines, and maps.
7. **Refrigerator Cabinet:** The refrigerator cabinet is available on select International® ProStar®+ Series long sleeper models and is located behind the passenger's seat.

8. **Drawer:** A small drawer is provided at the top of the refrigerator cabinet for storage.
9. **Work Table:** Pull-out work table. **Important:** A release latch is located on the right hand work table guide to allow the table to be stowed. To close simply depress the release latch and slide the work table shut.

### Horizontal Refrigerator

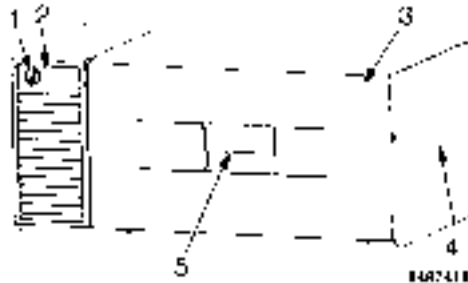

An optional horizontal refrigerator is available on select International® ProStar®+ Series sleeper models and is located under the lower bunk.

1. Control Knob/Thermostat
2. Power Indicator
3. Drawer
4. Refrigerator Cabinet
5. Lift Release Handle

### Dresser Cabinet

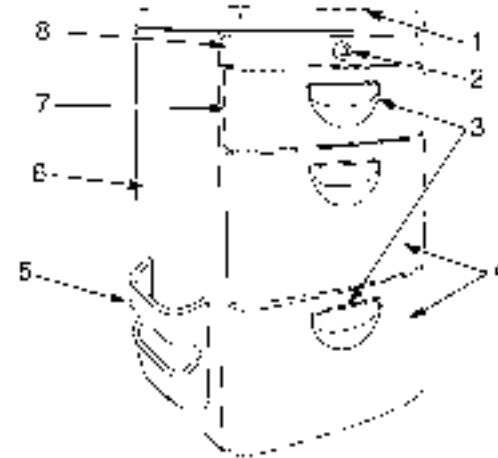

1487117

1. **Dresser Top:** The top of the dresser cabinet serves as a desk top.
2. **Release Knob:** A release knob is used to open the work table. To open, depress the knob, the knob will extend from the work table, then pull the work table open. To close the work table depress the tab, along the left side of the work table, and slide the work table shut. Once the work table is closed the knob needs to be pressed in to a flush position with the work table (this prevents the knob from getting hung on your clothing and other items as you move around in the sleeper compartment).

## Sleeper Features

3. **Lift Release Handle:** All drawers are equipped with lift release handles. To open the drawers, lift the handle from the bottom and slide the drawer open. To close, push the drawer shut until the lift release handle locks the drawer shut.
4. **Large Drawers:** Two large drawers are provided for storage.
5. **Magazine Pocket:** Provides a storage area for books, magazines, and maps.
6. **Dresser Cabinet:** The dresser cabinet is available on select International® ProStar®+ Series long sleeper models and is located behind the passenger's seat.
7. **Small Drawer:** One small drawer is provided at the top of the dresser cabinet for storage.
8. **Work Table:** Pull-out work table. **Important:** A release latch is located on the right hand work table guide to allow the table to be stowed. To close simply depress the release latch and slide the work table shut.

### Tower Wardrobe Cabinet

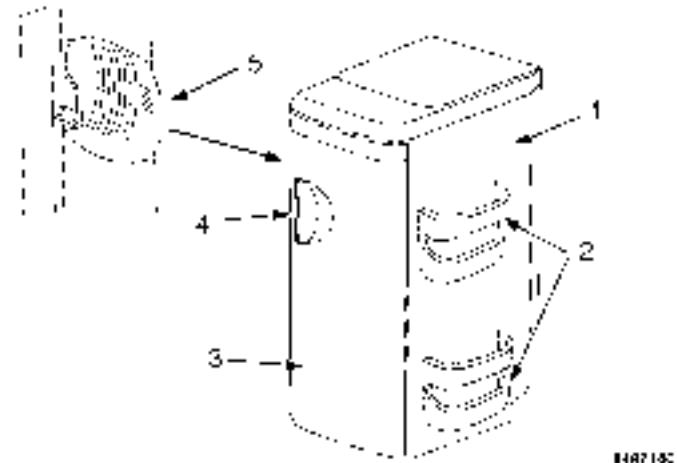

1. **Tower Wardrobe:** The tower wardrobe cabinet is available on select International® ProStar®+ Series long sleeper models and is located behind the driver's seat. The tower wardrobe cabinet provides hanging clothes storage. When equipped with the upper bunk option, the tower wardrobe cabinet provides steps for access to the upper bunk.
2. **Magazine Pocket:** Provides a storage area for books, magazines, and maps.
3. **Door:** The optional door is provided on select International® ProStar®+ Series sleeper models. Some models are fitted with no door or a snap-on cloth curtain.

4. **Lift Release Handle:** The optional door is equipped with a lift release handle. To open the door, lift the handle from the front and open the door. To close, push the door shut until the lift release handle locks the door shut.
5. **Internal Light:** The internal light is mounted on the tower wardrobe cabinets that are equipped with a door. This automatic light turns on as the door is opened and turns off when the door is closed.

### Rear Wardrobe Cabinet

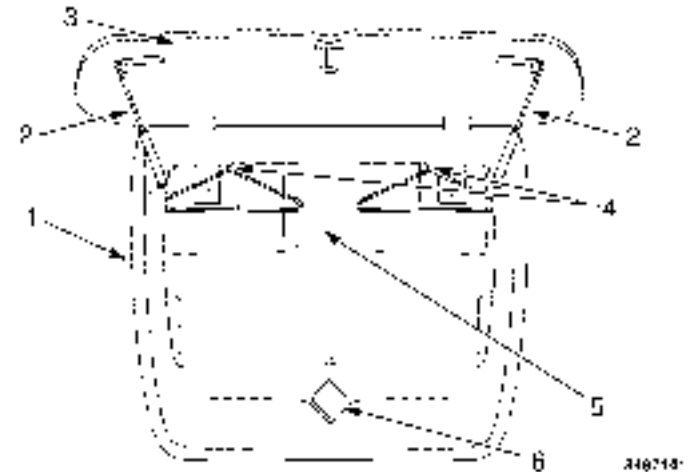

1. **Rear Wardrobe:** The rear wardrobe cabinet is mounted on the rear wall of International® ProStar®+ Series sleeper models and provides storage for hanging clothes. When an upper bunk is installed in the sleeper compartment, the rear wardrobe cabinet is not installed.
2. **Gas Shocks:** The rear wardrobe is fitted with two gas shocks to aid in opening, closing, and supporting the rear wardrobe in the opened position.
3. **Door:** The door is provided on select International® ProStar®+ Series sleeper models. Some models are either fitted with no door or a snap-on zipper cover.

## Sleeper Features

---

4. **Hanging Closet:** Provides storage locations for hanging clothes.
5. **Mirror:** A mirror is provided with the rear wardrobe.
6. **Logo Button:** The logo button is used for opening the rear wardrobe cabinet. To open, push the logo button with one hand while lifting the door with the other hand. To close, lower the door to the closed position, apply pressure to the bottom latch area, and the door will lock shut.

## Airline Cabinets

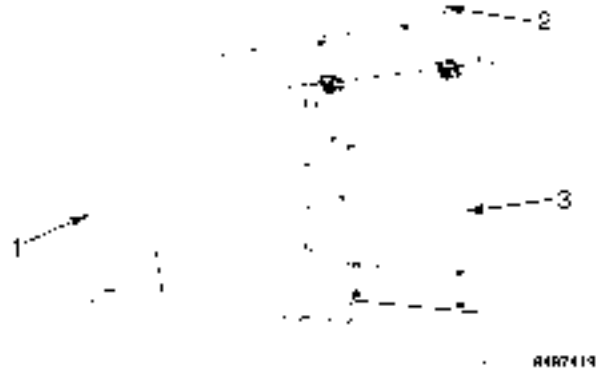

1. **Airline Cabinets:** These airline-style cabinets are mounted at the top of the side walls and can come in configurations of one, two, or three cabinets on each side of select International® ProStar®+ Series sleeper models.
2. **Door:** Each airline cabinet is provided with its own pull-down door to secure stored items.
3. **Interior Storage:** Interior storage is provided to secure items away from sight and prevent them from moving around while the vehicle is in motion.

### Convenience Features

#### General Information

The sleeper cab is equipped with additional features that make living on the road easier and more convenient.

#### Sleeper Curtain

Privacy curtains are available on all International® ProStar®+ Series sleeper models to ensure privacy and to darken the cabin from outside light. Curtains are designed to separate the back of the driver/passenger seats and the sleeper compartment. When the curtains are not in use, they are easy to store by sliding them to the sides of the cab, wrapping the straps around them, and securing the straps to the snaps provided on the cab side walls.

#### Television Mount

Mounted behind the passengers seat and just below the airline cabinet is the optional television mount on select International® ProStar®+ Series long sleeper models. Straps are provided with the television mount to secure the television to the mount plate. A convenient antenna and power socket is located on the side wall next to the television mount.

#### Power Inverter

The power converter is available on select International® ProStar®+ Series sleeper models and is used for converting 12 Volt DC current to 120 Volt AC current, so that devices such as a refrigerator, TV, VCR, microwaves, hair dryers, etc. can be used within the sleeper compartment. Refer to the Power Inverter Manual for more information.

#### Power Sockets

Several 120 volt AC power sockets, for using electrical appliances within the sleeper, are distributed throughout the sleeper compartment .

#### Speakers

There are two standard coaxial speakers mounted on the rear wall of the sleeper compartment just above the lower bunk. An optional 10-inch subwoofer speaker is available for the sleeper compartment along with an amplifier that mounts under the lower bunk (driver side luggage compartment).

#### Floor Covering

The standard floor covering for the International® ProStar®+ Series sleeper compartment is a durable rubber mat with cushioned insulation under the rubber mat.

An optional carpet insert is available on select International® ProStar®+ Series sleeper models. It can easily be removed for cleaning.

#### Sleeper Fan

The optional sleeper compartment fan is mounted on the headliner just behind the passenger seat. The sleeper fan is equipped with a push-button switch for turning the fan on, off, and adjusting the fan speeds.





## SECTION 6 — OPERATION

### Operation Safety

#### General Information



Operation of a diesel engine near flammable vapors in the air may cause the engine speed to increase uncontrollably and overspeed. If this situation occurs, mechanical damage, fire, explosion, personal injury or death could result. Turning off the ignition switch will not slow or stop the engine due to uncontrollable fueling of the engine through flammable vapors being drawn into the engine air inlet. Operation of components such as starter, alternator, electric motors, etc. and static electricity could also ignite flammable vapors.

Do not operate the truck in the possible presence of flammable vapors unless both a complete hazard analysis is performed and necessary additional safety processes and/or equipment such as vapor testing, air intake shutoff devices, ventilation, etc. are utilized. The operator is responsible for using those processes and/or equipment to ensure that the diesel engine and all other components on the truck can be operated safely under the specific conditions and hazards that may be encountered.



Do not exceed the truck's gross axle weight, gross vehicle weight, and gross combination weight ratings. Exceeding these ratings by overloading can cause component failure resulting in property damage, personal injury, or death.



Always use occupant restraint system when vehicle is moving. Any location in the vehicle not equipped with a seat belt should not be occupied when the vehicle is being operated. In the event of a vehicle accident or sudden, unexpected movement, failure to properly use an occupant restraint system could result in personal injury or death.



Always use the ashtray(s) provided for disposing of cigar, cigarette, or pipe ashes and tobacco. Failure to use an ashtray is a fire hazard and could result in property damage, personal injury, or death.



When parking your vehicle, do not leave transmission in gear. Always use parking brake. When parking on a grade, chock wheels and turn front wheels to keep the vehicle from rolling into the traveled portion of the roadway. Failure to follow these procedures could cause an unattended vehicle to move, resulting in property damage, personal injury, or death.



Exhaust gases from engines contain hazardous compounds. Do not operate engines in enclosed areas without abundant forced ventilation (with garage doors and windows wide open). Maintain exhaust system in good operating condition. Breathing exhaust gases could result in personal injury or death.

This section contains information concerning the safe operation of your vehicle. It is extremely important that this information is read and understood before the vehicle is operated.

### Cab Controls

The cab controls and features are described in detail in the **Controls/Features** section of this manual. Read and understand the entire **Controls/Features** section of this manual before operating this vehicle.

## Seat Belts

### General Information



To prevent personal injury or death, do not ride in the vehicle cargo area or on the outside of the vehicle. Ride only in designated seating positions or sleeper berth with seat belts or bunk restraints fastened and properly adjusted.



Failure to properly inspect and maintain seat belts could result in personal injury or death.



Any seat belt in use during an accident must be replaced. When replacement of any part of the seat belt is required, the entire belt must be replaced, both retractor and buckle sides. Belt failure could result in personal injury or death.

**NOTE:** Periodically inspect the seat belts for wear and function. Replace any parts whose performance is in doubt.

**General Information**

Safety belts must be worn by the driver and all passengers at all times. Before adjusting or fastening the safety belt, move the seat forward or backward and adjust the seat height as necessary. Sit erect and adjust the seat cushion and seat back for a comfortable driving position. In the event of a collision, a correct driving position maximizes the effectiveness of the safety belt.

Tether straps are installed on all suspension-type seats. Tether straps help secure the seat to the floor and are intended to restrain the seat and safety belt in case of an accident or sudden stop. The tethers are not adjustable and do not need any adjustment.

**Operation**

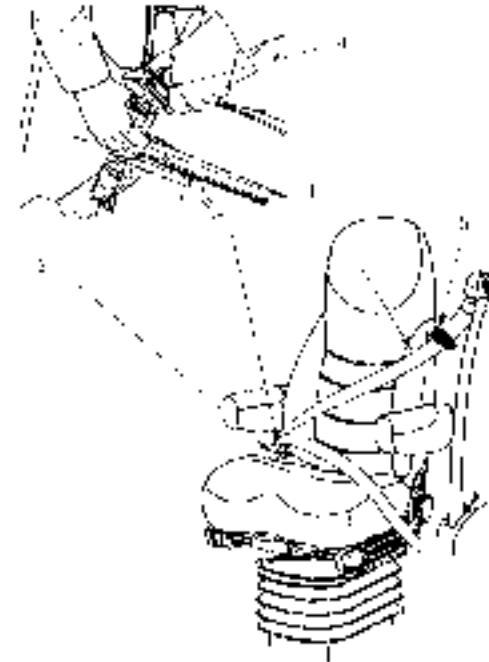

1. Three-Point Seat Belt
2. Retractor
3. Buckle
4. Tongue
5. Clip

## Operation

---

To operate the seat belt follow these steps:

1. Slowly pull the three-point seat belt out of the retractor and slowly pull it across your lap far enough to engage the buckle. If the retractor locks too soon, allow the seat belt to retract slightly, then slowly pull it out again.
2. To fasten the seat belt, insert the tongue into the buckle until it latches. Give the seat belt a firm tug to ensure that the buckle is securely fastened.
3. The seat belt must be free to slide through the tongue, allowing the belt tension to equalize across hips and chest. The retractor is a locking type that allows the seat belt to come out and to adjust for body movement.
4. The seat belt will return to the retractor as the body returns to its original position. The retractor will retain moderate tension across the body in its operation mode.
5. The seat belt is equipped with a clip to eliminate the moderate belt tension across the body. It can be adjusted by pressing the button and sliding the clip along the seat belt.
6. To release the seat belt, push the button release latch on the buckle and give the seat belt a tug to assist the seat belt into the retractor.

### Care of Seat Belts



**Do not bleach or re-dye seat belt webbing. Bleaching or re-dyeing may cause a weakening of the webbing, resulting in personal injury or death.**

Clean the belts occasionally with mild soap; do not use cleaning solvents or abrasives.

The entire seat belt assembly should be inspected periodically for corrosion, wear, fraying or weak spots. The retractor, latch, and buckle should be checked for proper function, and all seat belt mounting bolts should be tight at all times.

## Seats

### General Information



Do not adjust driver's seat while vehicle is moving. The seat could suddenly or unexpectedly move causing the driver to lose control of vehicle, which could result in property damage, personal injury, or death.



Reckless operation of this vehicle over rough roads or surfaces can cause loss of vehicle control and result in property damage, personal injury, or death. Use caution and reduce speed. Properly adjusted seats and seating systems may not compensate completely for severe road conditions. Ensure that head clearance will be maintained during all road conditions, as the seat may move up and decrease the available space.

There are several seat options that can be used in the International® ProStar®+ Series vehicle. If a different seat assembly than the one listed below is installed in your vehicle, see your authorized International® Truck Dealer.

The air suspension seats for the driver and passenger are equipped with features that adjust for maximum comfort and safety. Depending on which models are installed in the vehicle, some of these features may not apply.

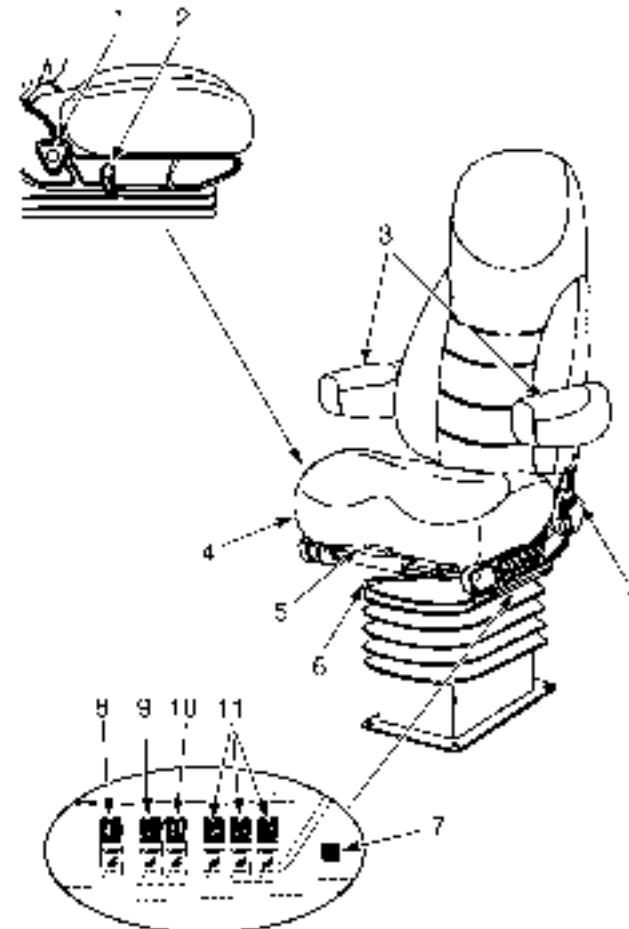

8487100

## Operation

| Seat Controls and Adjustments |                           |   |
|-------------------------------|---------------------------|---|
| Item No.                      | Item                      | Description   |
| 1                             | Backrest Tilt             | By rotating the handle, the backrest recline angle can be adjusted.   |
| 2                             | Chugger Snubber           | Moving the handle down isolates the seat from the fore and aft movement of the cab.   |
| 3                             | Armrests                  | Armrests can be adjusted by lowering/raising to desired angle.  |
| 4                             | Swivel Seat               | Turn release lock and press inward to allow seat to swivel towards the center and rear of the cab.  |
| 5                             | Cushion Front Tilt        | Pulling the handle up and out adjusts the tilt and length of the seat cushion.  |
| 6                             | Fore and Aft Movement     | Press the lever sideways to unlock the seat and adjust the fore/aft position.   |
| 7                             | Back Cyclor               | Pressing this button activates the lumbar massage feature.<br><br><b>NOTE:</b> This feature operates from the truck air supply and does not turn off automatically when the truck is shut down. To avoid depleting the air tank(s) during shutdown periods, make sure the Back Cyclor is manually turned off prior to shutdown. |
| 8                             | Ride Height               | Push the switch up to inflate the air bag and increase the ride height. Push the switch down to deflate the air bag and lower the ride height.  |
| 9                             | Seat Cushion Side Support | Push the switch up to inflate the seat cushion side supports. Push the switch down to deflate the seat cushion side supports.   |
| 10                            | Backrest Side Support     | Push the switch up to inflate the backrest side supports. Push the switch down to deflate the backrest side support.  |
| 11                            | Triple Lumbar             | These three switches operate the three chamber lumbar supports. Push each switch up to inflate either the upper, middle, or lower chamber, and push each switch down to deflate the chambers.   |

## Starting Procedures

### General Information



Never start the engine unless you're sure the transmission selector is in neutral and the brake is applied, otherwise accidental movement of the vehicle can occur, which could result in property damage, personal injury, or death.



**DO NOT** crank the engine for more than 30 seconds at a time; wait two minutes after each try to allow the starter to cool. Failure to follow these instructions could cause starter damage.

**NOTE:** Before starting the engine:

- Read and understand the **Controls/Features** section of this manual.
- Perform the left and right engine compartment inspections outlined in the **Inspection Guide** section of this manual.
- If your vehicle has an optional battery disconnect switch, be sure that it is in the on position. This switch is cab mounted, or mounted on the battery box.

**NOTE:** Automated manual transmissions must be in neutral and vehicles with a clutch pedal require the clutch pedal to be depressed before the starter will engage.

### Engine Starting

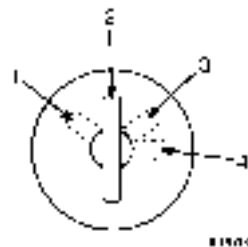

The ignition switch has four key positions as follows:

1. ACC (Accessory)
2. OFF
3. ON
4. START

1. Apply the parking brake and place the transmission in the neutral position. If equipped with a clutch pedal, the clutch pedal must be depressed.
2. Turn OFF the headlights and all accessories.
3. Turn the key clockwise to the ON position.
4. Turn the key to the START position.
5. When the engine starts, release the key.
6. The key will return to the ON position and the engine will continue to run.
7. To stop the engine, rotate the key counterclockwise to the OFF position.
8. To place the ignition switch in ACC (Accessory) position, rotate key counterclockwise to the ACC position. Accessory features can now be used without engine operation.

## Operation

---

9. To terminate ACC (Accessory) operation, rotate the key clockwise to the OFF position.

### After the Engine Starts

- Do not increase engine speed until the oil pressure gauge indicates normal pressure.
- Make sure the engine oil pressure is indicated on the gauge within 20 seconds after starting.
- Operate the engine for three to five minutes before operating at full power.
- Try to limit engine idle to 10 minutes. Excessive idling reduces fuel economy, and may decrease oil life.
- When starting a cold engine, increase the engine speed (RPM) slowly to make sure adequate lubrication is available to the bearings.

### Engine Shutdown

Idle the engine for three to five minutes before shutting down. This few minutes of idling allows the lubricating oil and water to carry heat away from components heat-soaked by hot combustion/exhaust gasses.

The larger the engine, the greater the need for this idling period. This will help avoid damage to turbocharger seals or like features of an engine which, after shut down, will no longer be cooled by the circulation of oil and coolant.

1. Place the transmission in the neutral position.
2. Apply the parking brake.
3. Turn off the headlights and all accessories.
4. Idle a hot engine for 2 to 5 minutes to allow the turbocharger to cool.
5. Rotate the key counterclockwise to the OFF position, and remove key from the ignition switch.

### Emergency Starting



**The following procedures must be performed exactly as outlined, otherwise a fire or a battery explosion could result in property damage, personal injury, or death.**

#### CAUTION

**To prevent damage to vehicle electronic components, voltage supplied to a vehicle's electrical system must never exceed 16.0 volts. This voltage must not be exceeded when the ignition switch is in the OFF, ACC, or IGN position, or during engine cranking. The most reliable means for jump starting a vehicle is to connect charged 12-volt batteries so as to provide controlled voltage. Never use an electric welder.**



**NOTE:** The International® ProStar®+ Series vehicle is equipped with a remote jump start stud, located on the back of the battery box, that eliminates the need to remove the battery box cover when jump starting is required.

1. To prevent shorting of the electrical system, remove metal rings or watches and do not allow metal tools to contact the positive terminal of battery or jumper cables.
2. Place transmission in Neutral and set parking brake in both the discharged and booster vehicle.
3. Shut all electrical loads in both vehicles.
4. Eye protection should be worn if available. If not available, shield eyes when near either vehicle's batteries.
5. DO NOT permit vehicles to touch each other when jump starting.
6. Connect one end of the first jumper cable to positive (+) terminal of the dead battery or (+) terminal of dead battery jump start stud and then connect the other end of the jumper cable to the positive (+) terminal of the booster battery.
7. Connect one end of the second jumper cable to the negative (-) terminal of the booster battery and the other end to chassis frame of the vehicle with the discharged battery. Do not attach the other end to the negative (-) battery terminal of the discharged battery, because a spark could occur and cause explosion of gases normally present around the battery.

8. With the engine running on the booster vehicle, allow the discharged batteries to charge for at least 5 minutes.
9. Attempt to start the discharged vehicle.
10. Reverse above procedure when removing the jumper cables.

### Cold Weather

#### *General Information*



**Explosion Hazard. Do not use volatile starting aids such as ether, propane, or gasoline in the engine air intake system. Glow plugs and/or grid heater will ignite vapors, which can cause severe engine damage, personal injury, or death.**

#### *Cold Weather Starting*

There are two optional features available on the International® ProStar®+ Series truck for frequently operating the vehicle in cold climates.

**Ether Injection System:** This temperature controlled system is automatically activated at air temperatures below 32° and injects a safe, metered amount of ether prior to engine cranking. The ether injection system is mounted to the left frame rail under the hood.

**Engine Block Heater:** For cold climates an optional engine block heater is available. The block heater utilizes an external

## Operation

---

power source to keep the engine coolant warm and a 120-volt socket for connecting to the external power source. The 120-volt socket is mounted below the driver's side door.

### *Cold Weather Operation*

In order to operate the engine in temperatures of 32° F (0° C) or lower, observe the following instructions:

- Make certain that batteries are of sufficient size and in fully charged condition. Check that all other electrical equipment is in optimum condition.
- Use permanent type engine antifreeze solution to protect against damage by freezing.
- At the end of each daily operation, drain water from fuel/water separator, if equipped.
- Fill fuel tank at end of daily operation to prevent condensation in fuel tank.
- Be sure to use proper cold weather lubricating oil, and be sure crankcase is at proper level.
- At temperatures of 20° F (-6° C) and below, it is recommended that you use an engine block mounted coolant heater to improve cold starting.
- If operating in arctic temperatures of -20° F (-29° C) or lower, consult your International® Truck dealer for information about special cold weather equipment and precautions.

### *Engine Idling*

#### **CAUTION**

**Because diesel engines are highly efficient, they use very little fuel while idling. As a result, idling in cold weather will not heat the engine to its normal operating temperature. This in turn can cause a build-up of heavy deposits of carbon and rust on valve stems causing them to stick. Sticking valves can cause significant valve train damage. The colder the ambient temperature, the more likely this will occur.**

The following cold weather idling guidelines must be followed:

- Avoid extended idling (beyond 10 minutes) whenever possible to maximize engine and Diesel Particulate Filter (DPF) life. See Exhaust Filter Regeneration in this section for more information.
- Use a minimum 40 Cetane diesel fuel or utilize Cetane Index improvers from a reputable manufacturer.
- Maintain engine cooling system.
- Do not shut engine down after extended idling period. Drive the vehicle under load for several miles at normal operating temperatures to burn off any accumulated carbon and varnish in the exhaust DPF.
- Consider use of engine block heaters and approved winter-fronts where conditions warrant.

### *Engine Idle Shutdown Timer (Optional)*

This vehicle may be equipped with an optional Idle Shutdown Timer that will limit engine idle time to comply with certain state and local regulations and/or owner/operator preferences. If the optional Idle Shutdown Timer is enabled, the engine will shutdown after a pre-programmed time of extended idling. This will also shut down all electrical loads except for lights. Allowable idle times may vary from state to state and with owner/operator preferences. Idle times may also be dependent on vehicle conditions such as Parking Brake status, PTO (if equipped) status, transmission status and others.

The vehicle owner or operator is responsible for compliance with all state and local regulations.

If the vehicle has this system enabled, the yellow IDLE SHUT DOWN indicator in the instrument panel gauge cluster will turn on 30 seconds before engine shutdown. This indication will continue until the engine shuts down or the system is reset.



### *Winter Front Usage*

Unless extremely cold conditions exist, the use of winter fronts or other air restrictive devices mounted in front of the radiator is not recommended on International® ProStar®+ Series vehicles,

which are equipped with engine charge air coolers. Cooling air flow restriction affects emissions and can cause high exhaust temperatures, power loss, excessive fan usage, and a reduction in fuel economy. If you insist on using a winter front, the device should have a permanent opening above or directly in line with the fan hub. The opening's minimum dimension must be at least 120 in<sup>2</sup>. (774 cm<sup>2</sup>).

### **Hot Weather Operation**

1. Keep cooling system filled with clean permanent antifreeze solution to protect against damage by overheating.
2. Fill fuel tank at end of daily operation to prevent condensation in tank.
3. Keep external surface of engine, radiator, charge air cooler, AC condenser, and accessories clean to avoid dirt build-up.

Excessive coolant temperature could be experienced while driving in too high of transmission gear ratio, which would lug the engine. To correct the problem, engine speed should be increased by down shifting into the next lower gear to increase engine RPM's which will increase coolant flow through the radiator and increase fan speed.

### Operating Instructions

#### General Information



**All vehicles have blind spots. Make sure your way is clear in all directions before moving your vehicle. Failure to follow these procedures could result in property damage, personal injury, or death.**



**Operating an engine beyond the maximum governed speed could result in engine failure and cause vehicle damage, personal injury, or death.**

#### Steering

Be alert to any change (feel) in steering when driving. This change or feel includes increased steering effort, unusual sounds when turning, excessive wheel play or pulling to either side. If any of the above are detected have the vehicle inspected and repaired at once by a qualified mechanic.



**Do not adjust the steering column while the vehicle is moving. It could suddenly or unexpectedly move causing the driver to lose control of vehicle which could result in property damage, personal injury, or death.**



**Do not lubricate the tilt or telescoping steering mechanism.**

### Adjustable Steering Column

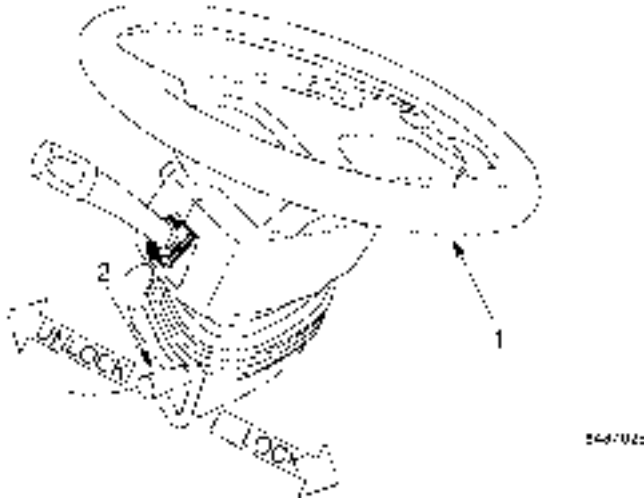

1. Steering Wheel
2. Release Handle

If equipped with the optional tilting and telescoping steering column, the steering wheel can be adjusted as follows:

- Grasp the steering wheel with your right hand and unlock the release handle with your left hand, by pushing forward on the release handle.
- Using both hands, grab the sides of the steering wheel and adjust the telescoping feature to the desired position and then the steering wheel tilt to the desired position.
- Hold the steering wheel in the newly acquired position with your right hand and pull THE RELEASE HANDLE backward towards you, to the locked position, with your left hand.
- Make certain the steering wheel is in the proper position and the column is locked.

### General Information

- Start the vehicle in motion by utilizing the highest gear speed in the transmission that will enable the engine to easily pull the load without slipping the clutch. Accelerate smoothly and evenly to engine rated speed. Rapid acceleration will result in high fuel consumption.
- When approaching a hill, depress accelerator smoothly to start the upgrade at full power, then shift down as needed to maintain vehicle speed.
- Prevent over-speeding of the engine when going down long and steep grades. The governor has no control over engine speed when it is being pushed by the loaded vehicle. Operate in a gear that will permit an engine speed below the Maximum Governed Speed or High-Idle RPM (no load).

## Operation

---

### Electrical

#### *Alternator*

#### **CAUTION**

**Improper usage of fast charger, hook-up of booster battery or installing battery can cause damage to the electrical system or to the alternator.**

Many alternators used in International® Truck vehicles are of the self-energizing type. Some engines may need to be briefly revved after starting to turn on the alternator. The alternator will then charge at idle. If the vehicle is to be warmed up prior to beginning operation, the operator should observe the voltmeter for charging indication before leaving the vehicle.

#### *Battery*



**Keep lighted tobacco, flames, sparks or other ignition sources away from the batteries. Gas from the battery cells is flammable and can ignite and/or explode. This is particularly true when jumper cables are being used. Battery fires or explosions could cause personal injury, including severe injury to the face, eyes, limbs and body.**

**In addition, inhaling the hydrogen gas produced by the normal operation of the battery could result in partial or permanent damage to the respiratory system which may result in death.**



**Whenever disconnecting battery terminals, always disconnect ground terminal first. When reconnecting, always connect ground terminal last. Failure to follow this procedure could result in a short to ground and cause property damage, personal injury, or death.**

**Always wear eye protection when working around batteries. Do not attempt to jump-start a vehicle with a frozen battery because the battery may rupture or explode. If a frozen battery is suspected, thaw out battery and recharge.**



**DO NOT Check Battery Condition By Shorting (Flashing) Across Terminals. Failure to follow this warning could result in property damage, personal injury, or death.**

When working around the terminals and battery, use extra care to avoid shorting. A good practice is to use insulated pliers and screwdrivers.

*BATTERY ON Indicator*

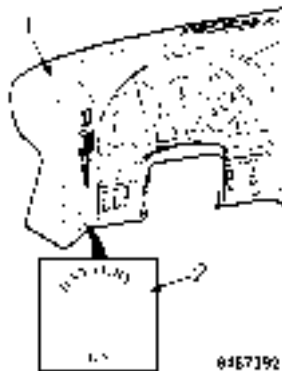

1. Left Side of Dash
2. BATTERY ON Indicator

If the vehicle is equipped with a battery disconnect switch, an optional BATTERY ON indicator may be located on the left side

of the instrument panel gauge cluster. The green BATTERY ON indicator will illuminate any time the battery disconnect switch is in the ON position (batteries connected) regardless of the key state. This indicator can easily be viewed with the driver door open and without entering the vehicle.

*Circuit Breakers, Fuses and Fusible Links*



**Electrical circuits are designed with a particular wire gauge to meet the fuse and circuit breaker current rating. Do not increase size of fuse or circuit breaker or change type of breaker supplied with your truck. To do so could cause wiring to overheat and possibly burn, resulting in a fire which could cause property damage, personal injury, or death.**

- Electrical circuits are protected either by the electrical system controller, circuit breakers, fuses or fusible links. For the size and location of circuit breakers, fuses and fusible links, please refer to the **Maintenance Intervals and Specifications** section of this manual.
- Fusible links consist of a length of lighter gauge wire in a circuit. In case of a short or overload, the fusible link opens (burns out) to protect the remainder of the circuit. Repair consists of installing a new fusible link with the same gauge wire as the opened fusible link.

## Operation

---

- Circuit breakers interrupt the circuit when an overload or short occurs. Manual circuit breakers (Type III) can be reset by depressing the reset button on the breaker. Headlamp and wiper circuits are protected by the Body Controller. Type II circuit breakers will reset automatically if the short is removed from the circuit.
- The various electrical units in the cab and engine compartments are protected by either fuses or circuit breakers. The power distribution center is located within the instrument panel (glove box area) on the passenger side of the vehicle.

### *Electrical Load Control and Shedding (ELCS)*

Electrical Load Control and Shedding (ELCS) is an optional feature (standard with sleepers) intended to provide a convenient means of automatically shutting down electrical loads overnight in order to conserve energy and deliver sufficient power to start the engine. The system is active when the engine is not running, regardless of key state. The ELCS system does not include provisions for shutting down 120VAC circuits.

The ELCS will begin a sequence of events when the measured battery voltage is at or below 12.1VDC for a period of 30 seconds. The sequence of events will first start with providing the visual alert “Load Shedding” to the vehicle operator for at least 30 seconds. An audible alert, which consists of a continuous tone, greater than 3 seconds and less than 6 seconds in duration, will coincide with the start of the visual alert.

The audible alert can be disabled by a vehicle maintainer if desired. The sequence will then disable a predefined group

of features/electrical loads. These will remain disabled until the vehicle’s key switch transitions to the Accessory or ON positions, and the measured voltage is above 12.1VDC.

### **Engine**

The engine for this vehicle is an electronically controlled diesel engine. A separate ECM (electronic control module) monitors and controls all engine functions. This ECM also communicates with the body electrical system which will generate or activate the necessary warning indicators to alert the driver of out-of-range operating conditions.

For complete information on the engine in this vehicle and its optional features, refer to the Engine Operation and Maintenance Manual supplied with this vehicle.

**NOTE:** For information pertaining to fuel and requirements refer to the Engine Operation and Maintenance Manual provided with the vehicle.

### *Charge Air Cooler*

All MaxxForce® engines are equipped with a charge air cooling system. The function of the charge air cooler is to cool the hot compressed air before it enters the engine’s intake manifold. This system uses ambient air as the cooling medium by allowing the intake air to pass through a network of heat exchanging fins and tubes prior to entering the combustion chamber. The resulting cooler intake air is denser than uncooled air and will allow additional fuel to be injected for greater power while helping to reduce emissions.



*Electronic Engine Controller*

Each vehicle contains an Engine Operation and Maintenance Manual in the driver's door pocket. Refer to the Engine Operation and Maintenance Manual for detailed information on these engine control systems.

*Engine Brake*



**Do not use the engine brake on slippery road surfaces. Doing so may cause wheel slippage and/or loss of vehicle control, which could result in property damage, personal injury, or death.**

**NOTE:** The engine brake should never be considered a substitute for the vehicle service brakes. The service brakes should always be viewed as the primary vehicle braking system. The engine brake cannot bring the vehicle to a complete stop. Only the service brakes can bring the vehicle to a complete stop.



All of the optional braking features are controlled by the driver, using the ENGINE BRAKE ON/OFF switch on the steering wheel and the ENGINE BRAKE 1/2/3 power level selector switch located in the Center Control Switch Panel.

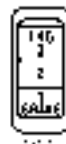

To activate the engine brake, press the push button ENG BRAKE ON/OFF switch on the steering wheel (pressing this switch again will deactivate the system). The ENGINE BRAKE SELECTOR 1/2/3 switch is then used to adjust the amount of braking applied.

Using engine braking features can extend brake lining life. The features also allow the driver to slow the vehicle down or maintain a constant speed on steep road grades that would otherwise result in prolonged use of the service brake that could cause brake fade. Refer to the Engine Operation and Maintenance Manual for detailed information on the engine braking system.

*MaxxForce® 11, 13 and 15 Engine Brake With Eaton AutoShift®/UltraShift® Transmissions Special Driver Instructions*

Low or manual transmission mode can be used to maximize engine brake performance.

- Keep engine speed as close to 2250 rpm as possible.
- Maintain brake pedal application until any desired downshifts are completed. Failure to do so may cause missed shifts.
- The gear display on the shift selector will stop blinking when the downshift is completed, and the driver will notice resumption of engine braking as an indication that the shift is completed.

When the transmission is in manual mode, engine protection upshifts are disabled. This could result in an undesirable engine overspeed condition. It is the operator's responsibility to prevent

## Operation

---

mechanical damage to the truck. Under these conditions, use service brakes and select the appropriate gear, as required, to keep the engine rpm within operating limits.

### *MaxxForce® Engine Features*

The MaxxForce® engines are electronically controlled diesel engines. The engine Electronic Control Module (ECM) monitors and controls the injection process and other engine functions. The ECM also communicates with the Body Controller (BC) and alerts it to out-of-range operating conditions. The BC in turn, generates engine function indicators and warning indicators. Since many of the engine performance features are owner selectable and electronically programmable, some of the operating parameters will vary from vehicle to vehicle. Some of these standard and optional monitored engine operating functions and warning indicators include:

Some standard features:

- Engine Warm-Up Control - (ECM) adjust injector operation as required.
- Cold Ambient Protection (CAP) - to aid engine warm up and maintain engine temperature.
- Cruise Control - provides vehicle speed control.

Some Optional Features:

- Engine Warning System - this system illuminates the **Red** "Engine" indicator and actuates a beeper when warning thresholds for coolant temperature, engine coolant level, and/or low engine oil pressure are exceeded.

- Engine Shutdown System - this system shuts down the engine after 30 seconds of operation beyond critical threshold values for coolant temperature and/or oil pressure.
- Throttle Control for PTO Operation.
- Road Speed Limiting/Governor - programmable maximum speed.
- Idle Shutdown Timer - shuts down engine after 5 minutes of idle time.

### *Certified Clean Idle*

MaxxForce® 11, 13 and 15 engines have been designed to meet the new California Air Resources Board (CARB) idle reduction standards by generating less than 30-g/hr. NOx emissions when idling. These engines can be identified by the Certified Clean Idle decal located on the left side of the hood or driver door.

### *Self Diagnostics*

All MaxxForce® engine operating parameter Warning Indicators are located on the instrument panel gauge cluster. When the ignition switch is turned ON, the Engine Warning Indicators are illuminated and remain on while the ECM runs normal start-up tests, then goes OFF. If warning indicator stays on or comes on while operating the vehicle, it is an indication that the vehicle needs service. When the warning indicator is illuminated, a Diagnostic Trouble Code (DTC) will be generated. Take the vehicle to a service center as soon as possible as some optional features and or engine power may be lost while the indicator is lit.

### *Air Compressor Cycling*

The MaxxForce® 11, 13 and 15 liter engines can be equipped with one of two different types of air compressor and may have one or two cylinders.

- **Head Unloaded Air Compressor:** This single cylinder, constantly engaged air compressor works in conjunction with the air governor and air dryer to pump compressed air to the air dryer and air tanks. When additional compressed air is not needed air is shut off from the air compressor discharge line and confined to the air compressor cylinder and its head.
- **Clutched Air Compressor:** This high-capacity, two cylinder, air compressor is periodically engaged by using an on-off clutch. It works in conjunction with air governor and air dryer to pump air to the air dryer and air tanks. When additional compressed air is not needed, the clutch is disengaged, compressor speed goes to zero, and all air pumping ceases. This system provides relatively low cylinder temperatures and sound verses other compressors during the unloaded cycle. It is used to promote maximum fuel economy by eliminating pumping energy loss during the unloaded cycle.

As the compressor reaches approximately 130 psi (896 kPa), the air governor will, through various methods, stop the air compressor from pumping pressurized air to the air system. When the air pressure reaches approximately 110 psi (758 kPa), the governor signals the air compressor to resume pumping pressurized air to the air system. During normal

engine operation, this cycle will be evident by the fluctuation of the primary air tank pressure gauge.

### *Cooling System*



**To prevent personal injury or death from hot coolant or steam, use only the following procedure to remove the pressure cap from the radiator or expansion tank. Allow the engine to cool first. Wrap a thick, heavy cloth around the cap. Unscrew the cap slowly to allow pressure to release from under the cap. After the pressure has been released, the pressure cap may be removed.**



**Exercise great care when working on vehicles with running engines that are equipped with an automatic fan clutch. The fan engages when engine coolant reaches a predetermined temperature or the refrigerant pressure (if equipped with air conditioning) reaches a predetermined setting. The fan will start with no advance warning. Failure to observe these precautions could result in vehicle damage, personal injury or death.**

### CAUTION

**If the coolant should get extremely low and the engine very hot, let the engine cool for approximately 15 minutes before adding coolant; then, with the engine running, add coolant slowly. Adding cold coolant to a hot engine may crack the cylinder head or crankcase. Never use water alone.**

The cooling system in vehicles with MaxxFace® 11, 13 and 15 engines, is filled at the factory with Nitrite-free Shell Rotella® Ultra ELC (Yellow) coolant. International Truck recommends using only the approved coolant with the 2010 cooling packages, and will not warrant these cooling systems that have not utilized the recommended coolant.

The label on the deaeration tank provides additional coolant/antifreeze information. Consult the Engine Operation and Maintenance Manual for coolant service life details.

### *Engine Oil*

Keep oil level between the ADD and Full marks. Never operate an engine with oil level below the ADD mark.

To obtain an accurate engine oil level reading the vehicle must be parked on a level surface with the engine off for at least five minutes before checking the oil level. This will ensure the oil is level in the oil pan, and the circulated oil has had a chance to return to the pan. It is not necessary for the oil to be hot to obtain an accurate reading.

When checking the oil level, the dipstick must be withdrawn and wiped clean, then inserted all the way and again withdrawn for a true check.

Use only recommended viscosity engine oil. Refer to the Engine Operation and Maintenance Manual for engine oil specifications.

The lubricating oil in a diesel engine becomes dark in color after short periods of engine operation. This discoloration is not harmful to engine parts as long as the oil and oil filter element changes are performed at recommended intervals.

All International® ProStar®+ Series vehicles must use CJ-4 or later oil classifications to achieve maximum DPF cleaning intervals.

Refer to the appropriate Engine Operation and Maintenance Manual for proper oil viscosity choice.

### *Engine Performance Problems*

- Low engine power can be the result of a plugged fuel filter. Fuel filters can plug prematurely due to the use of fuel that is contaminated with a high amount of sediment, microbial growth, or water. Fuel that has been stored for longer periods of time may also reduce engine performance.
- Failure to maintain the vehicle as required in the Maintenance Instructions and Maintenance Intervals and Specifications sections of this manual, as well as any separately available Engine Operation and Maintenance Manual, can cause engine performance problems.

Too low of cetane number could cause hard starting and slower warmup and could increase engine noise and exhaust emissions.

**Fuel**

*Ultra Low Sulfur Diesel Fuel Requirements*

Ultra Low Sulfur Diesel (ULSD) fuel is required for all on-highway diesel engines used with advanced after-treatment systems (Diesel Particulate Filters – DPF). For complete details on fuel requirements, see the Engine Operation and Maintenance Manual supplied with the vehicle.

*Unacceptable Fuel Blends*

Biodiesel blends having more than 5 percent pure biodiesel are not within ASTM D975 diesel specifications.

To determine acceptable biodiesel and biodiesel blends, refer to the Engine Operator and Maintenance Manual for the applicable engine.

*Hazards of Diesel Fuel/Gasoline Blends*



**Never add gasoline, gasohol and/or alcohol to diesel fuel. This mixture creates an extreme fire and explosion hazard which could result in property damage, personal injury, or death.**

Blending of gasoline and/or alcohol with diesel fuel is not recommended due to the hazards of fire/explosion and the detrimental effects on engine performance.

As little as two percent volume gasoline mixed with diesel fuel will create a flammable/explosive mixture in the fuel tank vapor

space, which will pose an extreme fire/explosion hazard during refueling or engine operation.

*Additional Unsafe Practices*



**To prevent engine damage, do not mix propane with diesel fuel. Warranty claims will not be honored against engines that have used propane.**



**To prevent engine damage, do not mix engine oil with diesel fuel. Warranty claims will not be honored against engines that have used fuel mixed with oil.**

*Fuel and Lubricant Additives*

International trucks are designed and built to operate satisfactorily on fuels and lubricants of good quality marketed by the petroleum industry. Use of any supplementary fuel or lubricant additives is not recommended. Malfunctions attributed to the use of such additives or failure to follow recommended fuel or lubricant recommendations may not be covered by any applicable warranty.

*Fueling Procedures*

**NOTE:** If your vehicle is equipped with dual fuel tanks, be sure to read and understand the following information before refueling the vehicle.

## Operation

---

Dual tank systems are equipped with dual draw and dual return fuel line systems to equalize the fuel temperature and level between the dual tanks.

When refueling, be sure that both tanks are filled completely, as both tanks cannot be filled from one side.

### *Fueling Precautions*

**Federal Motor Carrier Safety Regulations require the driver or any employee of a motor carrier to observe the following requirements:**

1. Do not fuel a motor vehicle with the engine running, except when it is necessary to run the engine to fuel the vehicle.

2. Do not smoke or expose any open flame in the vicinity of a vehicle being fueled.
3. Do not fuel a motor vehicle unless the nozzle of the fuel hose is continuously in contact with the intake pipe of the fuel tank.
4. Do not permit any other person to engage in such activities as would be likely to result in fire or explosion.

### *Reserve Fuel*

No extra supply of fuel for the propulsion of the vehicle or for the operation of accessories shall be carried on any motor vehicle, except in a properly mounted fuel tank or tanks.

## Exhaust Diesel Particulate Filter Regeneration

This vehicle is equipped with a Diesel Particulate Filter (DPF) to meet 2010 emissions requirements. The DPF traps exhaust particulate matter generated by normal engine usage. Periodically, the engine control system will perform a “cleaning” of the filter, known as Normal Regeneration. This process is transparent to the operator and occurs during normal vehicle operation.

In some cases the engine control system is unable to manage soot levels in the DPF through Normal Regeneration. When this occurs the DPF indicator will illuminate solid YELLOW on the instrument panel gauge cluster advising that action must be taken. At this time the vehicle should then be driven at highway speeds, or pulled over to perform a Parked Regeneration (See Parked Regeneration Procedure). If no action is taken the DPF indicator will begin to flash indicating that the filter is full. The vehicle should then be pulled safely off the roadway and a Parked Regeneration should be performed. If the vehicle is driven beyond the initial two warning stages, a loss of engine performance (de-rate) will occur. Ignoring the need for a Parked Regeneration, when required, can result in a warning for excessive exhaust temperatures, and a requirement to shut the engine off and not restart it until the DPF has been serviced by a technician. It is important to perform a Parked Regeneration when required. Failure to do so could be mission disabling and result in the vehicle being towed.

See the following information for a detailed explanation of DPF indicators and the corresponding procedures that must be followed.



**Failure to perform a Parked Regeneration when exhaust filter indicator is ON will cause the engine to lose power and eventually shutdown.**

**When performing Parked Regeneration, make certain vehicle is safely off of the roadway and exhaust pipe is away from people, or any flammable materials or structures.**

**Failure to follow these instructions may result in a loss of engine power, vehicle speed, increased exhaust temperatures, and may cause an accident or fire resulting in property damage, personal injury, or death.**







There will be three levels of indication that the vehicle's exhaust filter is accumulating soot and needs to be cleaned, each with an increasing urgency for action.

**NOTE:** A Level 1 indication may disappear or a Level 2 may revert to a Level 1, if the vehicle is driven on highway at highway speeds for an extended period. This process of auto regeneration of the exhaust filter is activated when the engine load is increased as a result of highway driving at highway speeds. If the DPF indicator does not reduce in level or disappear, a Parked Regeneration must be performed.

**NOTE:** The following table is a typical representation of 2010 DPF emissions procedures (See visor for vehicle federal emissions label).

# Operation

## 2010 Federal Emissions Label

| Level   | Indication   | Audible Alarm   | LCD Text Message   | Vehicle Conditions/Operation  | Action Required  |
|---|--|---|--|---|--|
| 1   | <br>DPF<br>T11182<br>(Solid)    | None  | Scrolls between<br>See Visor for info<br>and Parked Regen<br>Required. | Exhaust filter<br>regeneration required.                            | Drive on highway at highway speeds or start Parked<br>Regeneration to prevent loss of power.   |
| 2   | <br>DPF<br>T11182<br>(Flashing) | None  | Scrolls between<br>See Visor for info<br>and Parked Regen<br>Required. | Exhaust filter is full.   | Pull vehicle safely off roadway and start Parked<br>Regeneration to prevent loss of engine power.  |
| 3   | <br>DPF<br>T11182<br>(Flashing) | An alarm will beep<br>continuously while<br>ignition is on. | Scrolls between<br>See Visor for info<br>and Parked Regen<br>Required. | Exhaust filter is full.<br>Engine performance is<br><b>LIMITED.</b> |  <b>WARNING</b><br><br><b>Pull vehicle safely off roadway and<br/>start Parked Regeneration to prevent<br/>engine stopping.</b> |
|  <b>Exhaust System Temperature is HOT</b><br><br> <b>WARNING</b><br><br><b>Exhaust components are operating under normal conditions and exhaust gases are at extremely high temperatures.<br/>When stationary, keep away from people and flammable materials, vapors, or structures or STOP ENGINE</b> |  |   |  |   |  |
|  A serious problem has occurred. Engine may <b>SHUTDOWN</b> soon. Pull vehicle safely of roadway, turn on flashers, set parking brake, place warning devices, and <b>STOP ENGINE</b> . Seek service immediately.   |  |   |  |   |  |



### *Parked Regeneration Procedure*

Perform the following steps to initiate Parked Regeneration (cleaning) of the exhaust filter:

1. Park the vehicle safely off the roadway and away from flammable materials.
2. Before initiating parked regeneration (using the ON/PARKD REGEN switch), the following conditions must be in place:
  - a. Parking brake must be set
  - b. DPF indicator illuminated (Solid or Flashing).
  - c. Transmission must be in Neutral (N) or Park (P), if available
  - d. Accelerator, foot brake and clutch (if present) pedals must not be depressed,
  - e. Engine temperature must be at a sufficient level to allow regeneration.

With some engines, this may be as high as 76.6° C (170° F).

**NOTE:** The engine coolant temperature must be above 76.6° C (170° F) before the parked regeneration procedure can be performed. If the engine coolant temperature is too low, the parked regeneration procedure will not activate.

3. Press the ON position of the ON/PARKD REGEN switch to initiate the regeneration cycle.

The engine speed will automatically ramp up to a preset RPM, PARKD REGEN ACTIVE will be displayed in the

information display, and the switch indicator will illuminate when the cycle is started. If the indicator is blinking, check to be sure that all conditions in step 2 have been met. Once started, the regeneration cycle will last approximately 30 minutes.

**NOTE:** If any of the above conditions are altered during the Parked Regeneration process, regeneration will be halted, and must be restarted.

4. When the regeneration cycle is complete, the switch indicator will go off, the engine rpm will return to normal idle and all exhaust filter warning indicators will be off. The vehicle may now be driven normally.



**NOTE:** In the event of an emergency situation where the vehicle must be moved after beginning Parked Regeneration, press PARKD REGEN position of the ON/PARKD REGEN switch to cancel Parked Regeneration.

### *Regeneration Inhibit Switch*

The optional Regeneration Inhibit switch is used to prevent the normal regeneration or parked regeneration processes.

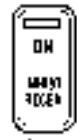

**NOTE:** There are two versions of the regeneration inhibit switch: the two-position and the three-position switch. Therefore, it's necessary to verify which version is installed in this vehicle. Both versions have the same switch labels.

## Operation

### *Two-Position Regeneration Inhibit Switch*

With the optional two-position switch, pressing the ON position of the ON/INHIBT REGEN switch will inhibit both normal and parked regeneration. Regeneration will be inhibited (latched) when in this position and the switch indicator is turned on.

### *Three-Position Regeneration Inhibit Switch*

The optional three-position switch is a center stable momentary switch. Pressing the ON position inhibits normal regeneration while the engine is running and is reset when the ignition switch is turned off. The Inhibit function is cancelled when the lower position is pressed, or parked regeneration is initiated (PARKD REGEN switch is turned to the ON position).

The switch indicator will be turned on whenever regeneration inhibit is enabled.

## Transmission

### *Manual Transmissions*

Vehicles with a manual or AutoShift transmissions have a clutch pedal that is used to engage or disengage the clutch, connecting or disconnecting the engine from the transmission and rear wheels. With the clutch pedal released (extended) the clutch is engaged, driving the transmission and rear wheels. Depressing the clutch pedal releases the clutch, permitting transmission gear changes.

Clutches will last many thousands of miles if properly used and maintained. **EXCESS HEAT IS A CLUTCH'S WORST ENEMY!**

Almost every early clutch failure can be traced to excessive friction heat. Do not ride or slip the clutch. Once a clutch is fully engaged, there is no heat generated and little or no wear. However, during the brief period when the clutch is picking up the load, considerable heat is generated. By riding or slipping the clutch, the period of partial engagement is lengthened, causing unnecessary heat and wear and reduced clutch life.

The International® ProStar®+ Series has many transmission options available. Refer to the Transmission Manual for information on the transmission available in your truck.

1. High Range
2. Low Range



**10-Speed Manual Transmission (standard):** The gear shift lever mechanically engages and disengages five forward gears and one reverse gear in the transmission front section. The range lever on the Roadranger Valve allows the operator to control an air shifted auxiliary section to provide a LO range and HI range. The five forward gear shift positions selected in LO range are used again in HI range to provide the 10 progressive

forward gear ratios. Once the highest shift lever position (5th gear) is obtained in LO range, the operator preselects the range shift lever for HI range. The range shift occurs automatically as the shift lever is moved from 5th gear position to the 6th gear position.

1. When operating off-highway, or under adverse conditions, always use the lowest gear when starting to move the vehicle.
2. For all normal conditions, use the highest gear that is still low enough to start the vehicle moving with engine idling, and without slipping the clutch excessively.
3. Use the clutch brake to stop gear rotation when shifting into low (or 1st) or reverse when the vehicle is stationary. The clutch brake is actuated by depressing the clutch pedal all the way to the floor.
4. Do not make range shifts with the vehicle moving in reverse gear.
5. Never attempt to move the range preselection lever with the gear shift lever in neutral while the vehicle is moving. Preselection with the range preselection lever must be made prior to moving the shift lever out of gear into neutral.
6. Do not shift from high range to low range at high vehicle speeds.
7. Double-clutch between all upshifts and downshifts.

8. After your shifting ability improves, you may want to skip some of the ratios. This may be done only when operating conditions permit, depending on the load, grade, and road speed. Transmissions with a greater number of speeds are optionally available. They may include the use of a splitter selector switch in addition to the range selector switch.

### *Engaging the Clutch*

- **Always start in the proper gear:** An empty vehicle can be started in a higher gear than a fully loaded one. But starting in a gear too high for the load can cause too much clutch slippage, generating excessive heat and unnecessary wear. A gear that will start the vehicle moving with the engine at idle speed is usually correct. If the engine must be revved up to prevent stalling, the gear selection is too high. As the clutch pedal is released and the clutch begins to engage, the engine speed will drop slightly. When this happens, fully engage the clutch and increase the engine speed. Increasing the engine speed before fully engaging the clutch can damage the clutch and drivetrain.
- **Do not upshift until the engine has reached proper speed.** Upshifting before the vehicle has reached the right speed will lug the engine.
- **When approaching a hill,** depress accelerator smoothly to start the upgrade at full power, then downshift as needed to maintain vehicle speed.

## Operation

---

- **Never hold a vehicle on a hill with the clutch.** To hold on a hill with the clutch requires that the clutch be purposely slipped. By doing this enough heat can be generated to burn up the clutch.
- **Never coast with the clutch disengaged.** This can cause clutch failure by the very high RPM encountered when coasting in gear with the clutch released. In this situation, the rear wheels are driving the disc through the multiplication of the rear axle and transmission ratios. This can result in over 10,000 RPM, which is beyond the burst strength of the facing material. Something as simple as coasting down an unloading ramp can burst a driven disc.

Re-engaging a clutch after coasting causes tremendous shock to the clutch and the whole drivetrain. It can result in internal engine damage and/or clutch and flywheel failure. Always report unusual clutch operation promptly. Proper maintenance, performed on time, will greatly extend the life of the clutch. The driver should report any change in free pedal (free travel) slippage or any strange feel to the clutch operation.

### Helpful Hints to Operate Vehicles with Ceramic Clutch Facings

1. Driver must start vehicle in first (low) gear.
2. While operating a ceramic clutch the driver has to engage the clutch before giving the engine any fuel (at idle).

3. The driver should not try to slip the ceramic clutch by raising engine RPM's and riding or feathering clutch pedal since the vehicle will experience erratic engagement.

Erratic engagement can cause engine stalling and potential serious damage to your vehicle's drivetrain components (i.e., clutch, transmission, driveshaft(s), rear axle).

### *Hydraulic Clutch Actuation System*

Clutch brake engagement occurs in the last 2 inches (50 mm) of pedal travel after initial clutch setup adjustment. Clutch wear will move the pedal position at clutch brake engagement toward the physical limit of travel. The hydraulic clutch system must have proper fluid bleeding before operating, usually performed at the factory, or at field servicing. Hydraulic clutch fluid should be drained and refilled every 2 years of service or after 200,000 miles (322,000 km) service interval.

### **CAUTION**

**To prevent vehicle or engine component damage, clutch pedal must engage clutch brake before the physical limit of pedal travel. When the clutch pedal position at clutch brake engagement is less than 0.5 inch (12.7 mm) from the physical travel limit, manual clutch adjustment is required for all Eaton® Easy Pedal® (EP) clutches.**

If non-self adjusting clutches are used in this application, it is important that clutch adjustments be maintained. Adjustment intervals should be every 20,000 miles (32,000 km). When utilizing an Eaton® EP clutch with a hydraulic clutch actuator,

the cab clutch pedal cannot be used to indicate when clutch adjustment is required. Drivers may not notice the need for clutch adjustment and continue to drive in such condition. Lack of adjustment will eventually lead to yoke interference with the clutch cover causing extensive clutch and or transmission damage.

When using the clutch brake, fully depress the clutch pedal and shift the transmission into either first or reverse gear. If the transmission does not go into first gear or reverse, toothbutting may be occurring. Slowly release the clutch pedal while applying light pressure on the shift lever until the transmission goes into gear. This will provide for a smooth shift into either a forward or reverse gear.

**NOTE:** After engagement of first gear, DO NOT use the clutch brake for upshifting and downshifting. To do so will shorten the service life of the clutch brake, and gear selection shift efforts may be increased. Clutch brake application occurs in the last 2 inches (50 mm) of pedal travel.

### *Double Clutch Procedures*

In order to properly upshift or downshift, be sure to do the following:

- Depress the clutch pedal to disengage the clutch.

- Shift the transmission into neutral.
- Release the clutch pedal.
- If upshifting, wait until the engine speed matches the transmission speed of the gear you desire to shift into.
- If downshifting, accelerate the engine until the engine speed matches the input speed of the gear you desire to shift into.
- Depress the clutch pedal immediately and shift into the desired gear.
- Release the clutch pedal to engage the clutch.

### *Clutch Precautions*

Maintain specified clutch adjustment. Regularly inspect clutch control linkage for tightness.

When adjustment of the clutch is necessary, it is extremely important that the work be properly performed; otherwise, early failure of the clutch will result and a costly clutch overhaul will be necessary.

To avoid needless delay and expense, allow only competent and experienced mechanics to perform these operations.

## Operation

---

### *Eaton AutoShift® Transmissions (Optional)*







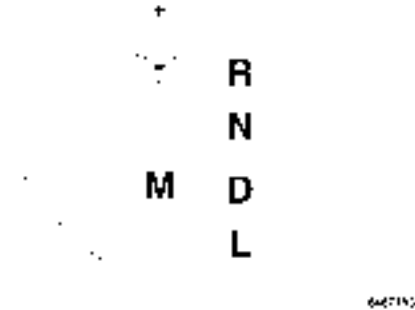



**To prevent unexpected vehicle movement, hold the brake pedal down while you move the gearshift from position to position. Hold down both brake and clutch pedal while pushing the “R” and “D” button. If you do not hold the brake pedal down, your vehicle may move unexpectedly and cause property damage, personal injury, or death.**

The optional Eaton AutoShift® transmission is a partially automatic transmission that automatically selects and engages the proper transmission gears. Vehicles are equipped with a clutch pedal that must be used when starting and stopping the vehicle.



To shift the Eaton transmission into Reverse (R) or Drive (D), first place foot on the brake and clutch pedal. When in Drive (D), the transmission selects the starting gear and automatically selects the proper gears for operating loads. If low (L) is selected while the vehicle is stopped, the transmission will remain in low gear until another gear is selected. If selected while in motion, the transmission will downshift when it is safe to do so. To place the transmission in neutral, press the (N) button. Manual mode should be used whenever the driver wants to select the shifts instead of letting AutoShift® transmission select them automatically. For operating instructions refer to the Transmission Manual.

The current gear selection and other information is also displayed on the instrument panel gauge cluster display.

| Automated Manual Transmission Controls |   |   |
|--|---|---|
| UPSHIFT                                |    | The UPSHIFT mode is used in the MANUAL mode to select upshifts.   |
| DOWNSHIFT                              |    | The DOWNSHIFT mode is used in the MANUAL mode to select downshifts.   |
| MANUAL                                 |    | Allows the driver to hold current gear and manually select the appropriate gear for road conditions using the upshift/downshift buttons. Manual mode should be used whenever the driver wants to select the shifts instead of letting Autoshift™ select them automatically. |
| GEAR DISPLAY                           |    | The GEAR DISPLAY shows the current gear position of the transmission. The GEAR DISPLAY will flash the target gear position of the transmission when in neutral during a shift.  |
| REVERSE                                |    | Selects Reverse gear once vehicle speed is less than 2 mph (3 km/h).  |
| NEUTRAL                                |    | Places the transmission in neutral.   |
| DRIVE                                  |   | Selects the default starting gear and automatically selects gears between the starting gear and top gear.   |
| LOW                                    |  | When Low mode is selected, the transmission downshifts at the earliest opportunity for maximum engine braking.  |

## Operation

---

### *Eaton UltraShift® Transmissions (Optional)*

The optional Eaton UltraShift® transmission is an automatic transmission that can automatically select and engage the proper transmission gears. Vehicles equipped with this transmission do not have a clutch pedal. For operating instructions refer to the Transmission Manual.

### *Clutch Brake*

**NOTE:** After engagement of first gear DO NOT use the clutch brake for upshifting and downshifting. To do so will shorten the service life of the clutch brake and gear selection shift efforts may be increased.

A clutch brake is used to stop transmission input shaft rotation so that the initial first or reverse gear selection can be accomplished when the vehicle is at a standstill and the engine is running at idle speed.

When using the clutch brake, fully depress the clutch pedal and shift the transmission into either first or reverse gear. If the transmission does not go into first gear or reverse, tooth butting may be occurring. Slowly release the clutch pedal while applying light pressure on the shift lever until the transmission goes into gear. This will provide for a smooth shift into either first or reverse gear.

### *Power Take-off Control*

If your vehicle is equipped with a power take-off (PTO), refer to the PTO equipment manufacturer's instructions.

## Rear Axles

### *Locking or Limited Slip Differentials*



**To prevent vehicle damage, personal injury, or death, pay strict attention to the following:**

**If your vehicle is equipped with any type of locking or limited slip differential, power will be transmitted to the opposite wheel should one of the wheels slip. Both wheels must be raised free of the ground should it be necessary to operate one wheel with the vehicle stationary; otherwise the wheel that is not raised will pull the vehicle off its support, possibly resulting in personal injury or death.**



**To prevent vehicle damage, personal injury, or death, pay strict attention to the following:**

**Care should be taken to prevent sudden accelerations when both drive wheels are on a slippery surface. This could cause both drive wheels to spin, and allow the vehicle to slide sideways, resulting in loss of vehicle control.**



### *Tandem Axle Power Divider Lock (PDL) Control*

#### **CAUTION**

**Do not operate the vehicle with the PDL engaged on dry pavement (good traction) continuously. This will result in excessive tire wear and premature axle wear.**

**Never engage the PDL when the wheels are spinning.**

The PDL should be engaged, which prevents inter-axle differential action, when backing under a trailer with a tractor, starting on a slippery surface (poor traction), operating off highway in mud, etc. (poor traction), or when traveling on slippery highways (poor traction). Failure to lock the power divider under these conditions may result in power divider failures and costly repairs. If you encounter wheel spin conditions, the PDL switch should be moved to the LOCK position.

#### **CAUTION**

**Engage the PDL only when stopped or moving at low speed. Never try to engage the PDL while the wheels are spinning as this may result in shock damage to the power divider components.**

When encountering slippery highway conditions (poor traction), the PDL can be engaged at a low, even speed. Momentarily

letting off the accelerator will engage the differential lock. A warning indicator on the instrument panel indicates when the inter-axle differential is locked.

When highway conditions improve (good traction), the PDL should be disengaged, again at a low, even speed. Letting up on the accelerator momentarily will unlock the inter-axle differential.

Tandem axle power dividers or inter-axle differentials in the forward rear axle are controlled by the dash mounted Power Divider Lock (PDL LOCK) switch.

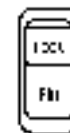

The switch indicator will turn on when the PDL is engaged (locked). The vehicle may be electronically programmed to provide an alarm when a speed is reached where it is not appropriate to have the power divider locked. In this event, an alarm will sound (5 beeps) and the switch indicator will flash slowly (once per second). A fast flashing (twice per second) switch indicator signifies a problem in the PDL system.

Under normal highway conditions (good traction), the PDL should be disengaged, which allows differential action between the forward rear axle and the back rear axle preventing inter-axle differential wear due to unequally worn or mismatched tires, etc.

## Operation

---

### *Driver Controlled Differential Lock*

The Differential Lock feature locks together the axle's left and right axle shafts for improved traction on reduced traction surfaces.

Some vehicles are equipped with this optional driver controlled differential lock feature (DIFF LOCK). The air actuated traction device can be manually shifted from the vehicle cab. By actuating a switch, mounted on the instrument panel, the driver can lock or unlock the rear axle differential(s) when the vehicle is moving or stopped.

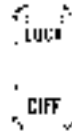

Other vehicles with tandem rear axles (6X4) are equipped with two optional driver controlled differential lock features (DIFF FR AXLE/LOCK and DIFF RR AXLE/LOCK).

The air actuated traction devices can be manually shifted from the vehicle cab. By actuating the switches, mounted on the instrument panel, the driver can independently lock or unlock the forward-rear and/or rear-rear axle differentials when the vehicle is moving or stopped.

When the differential is fully locked, the vehicle will have a slight "under-steer" condition. This will increase the turning radius of the vehicle.

On vehicles with multiple drive axles, the differential lock can be used in conjunction with the Power Divider Lock (PDL) to achieve maximum available traction in adverse road surface conditions.

To limit stress on the axle and tires during vehicle turning maneuvers and improve stability, the use of the differential lock

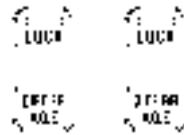

must be limited to low vehicle speeds, under 25 mph (40 km/h). Also, to maintain vehicle stability, the differential must not be locked when the vehicle is traveling down steep grades and traction is minimal. DIFF LOCK will automatically disengage when vehicle speeds exceed approximately 25 mph (40 km/h).

Do not engage the locking differential when the tires are spinning.

The vehicle may need to be decelerated or turned once or twice for the differential lock to fully disengage.

### **Rear Suspension**

#### *Rear Air Ride Suspension*

**CAUTION**

**The vehicle must not be operated on the road without air in the suspension air bags. Failure to observe this will result in ride degradation and suspension damage.**

Rear Air Ride Suspensions automatically adjust to different loads to maintain constant frame height. The system maintains vehicle ride quality and driver comfort.

#### *Rear Air Suspension Air Dump*

This feature also allows the rear of the vehicle to lower several inches for trailer attachment/detachment.

The system is controlled by the two position SUSP/DUMP switch with an indicator light in the DUMP position. This switch controls solenoids, which direct air to the suspension dump and height valve.



When the SUSP/DUMP switch is in the DUMP position and the vehicle speed is below 5 mph (8 km/h), air supplied to the rear air suspension is released, lowering the frame for loading.

Placing the switch in the SUSP position causes air to fill or remain in the air suspension for proper operating ride height.

The SUSP/DUMP switch will operate the IROS system only if the ignition switch is in either ACC or ON positions and the air tanks have sufficient pressure to fill the suspension. When the ignition switch is turned off, power to the solenoid will be removed, therefore, the suspension will remain in the state last set by the SUSP/DUMP switch.

**NOTE:** The suspension will dump when the ignition switch is in the either ACC or ON position, but will only fill when the ignition switch is in the ON position.

**NOTE:** The SUSP/DUMP switch functions will be inhibited by either a Traction Control or ABS event. In either event for either SUSP or DUMP operation, the ASD switch will have to be manually recycled after the event has passed in order to complete the operation.

**NOTE:** The electrical system will automatically switch from DUMP to SUSP if the vehicle speed exceeds 5 mph (8 km/h). Once this occurs, the only means to deflate the suspension will be to slow the vehicle to 5 mph, and recycle the SUSP/DUMP switch to the DUMP position.

### *Air Suspension System Faults*

- The instrument panel gauge cluster will issue an audible 10 beep alarm whenever the driver pushes the DUMP position of the SUSP/DUMP switch, and the vehicle exceeds 5 mph (8 km/h).
- The SUSP/DUMP switch indicator will blink rapidly in the event of a system component failure or a bad system signal status, when the SUSP/DUMP switch is in the DUMP position.
- The SUSP/DUMP switch indicator will blink slowly in the event of an ESC command fault, regardless of the position of the SUSP/DUMP switch.

## Brakes

### General Information



**Always check and maintain brakes in proper condition and adjustment. Out of adjustment brakes could cause reduced braking ability and result in property damage, personal injury, or death.**

### Downhill Operation



**Do not attempt to gear down if the engine is at or near maximum speed (RPM). Under these conditions it will be impossible to shift into a lower gear and could result in possible vehicle runaway, resulting in property damage, personal injury, or death.**

Always descend hills with extreme care, relying primarily on the engine braking effect to control vehicle speed. Heed warning signs posted for any grade. Stop and check brakes for condition and adjustment at available pull off areas before starting a descent.

#### Observe the following precautions:

- Never coast downhill. Service brakes alone should not be used to control speed on major downgrades. Brakes will fade from overuse.
- Downhill speed is controlled by removing one's foot from the accelerator pedal (engine running with closed throttle) and putting the transmission/rear axle in reduced gear. If the transmission/rear axle is in a gear that results in more than the appropriate speed, a proper downshift should be made to avoid overuse of the brakes. If the proper gear selection was not made and the brakes were overused, then stop the vehicle and wait for the brakes to cool. After the brakes have cooled, continue down grade in a lower gear range.

- The common rule to follow in using the engine and transmission/rear axle to control vehicle speed is to select a lower gear going down the hill than would be required to ascend the hill. There are some exceptions, such as going down a short hill with good visibility and no hazards.
- The service brakes should be used to supplement available vehicle retardation methods. When descending long grades requiring use of the brakes, short applications (three to five seconds duration) should be made rather than long, continuous applications. This minimizes temperature rise, brake fade and air consumption of air brake system.

### Air Brakes

#### General Information



**Stopping distance may increase under the failed condition since only one section of the brake system is operating. Reduce speed and employ safe driving practices. Have brake system repaired immediately. Loss of braking capability could cause an accident and result in property damage, personal injury, or death.**

The truck types covered in this manual are equipped with a split brake system.

The purpose of this split system is to provide a means of stopping the vehicle should a failure occur in either the primary or secondary brake system. In the event air pressure loss

occurs in one system, the remaining system continues to provide braking action.

When a failure is detected the air dryer is provided with a limp home feature to allow the vehicle to be driven to a service center.

If vehicle has been parked for an extended period in cold weather, always check to be sure all wheels are rolling free (brakes are not frozen) when starting out. Always clean accumulated ice and snow from brake linkage.

### *Air Gauge, Low Air Pressure Beeper and Warning Indicator*



**To prevent loss of vehicle braking or control resulting in property damage, personal injury, or death, never operate the vehicle when insufficient air pressure (less than 60 psi [414 kPa]) is indicated for either the primary or secondary air system. The volume of air required to stop the vehicle may be greater than that available. Have the brake system checked and repaired before returning the vehicle to service.**

Should air pressure in either section of the split air brake system be reduced to 60 to 76 psi (414 to 524 kPa) the warning beeper will sound and the red BRAKE PRESSURE warning indicator, on the instrument panel, will glow. Also, the air gauge/gauges will indicate low air pressure in at least one of the independent systems. The warning beeper and red indicator will automatically shut off when the air pressure in both systems

is sufficient (approximately 55 to 76 psi [379 to 524 kPa]) to operate the vehicle.

Should the red indicator and beeper not shut off soon after start-up, the air pressure gauge/gauges should also indicate at least one section of the split system has low air pressure. If the red indicator, beeper and gauge indicate a loss of pressure while driving, the vehicle still has a portion of the braking capability, because one-half of the split system braking capability is retained. However, the distance required to stop the vehicle will be increased.

### *Reservoir Moisture Draining*

The Bendix AD-IS® air dryer automatically drains the wet tank. Daily draining is not required.

Moisture taken in with the air through the compressor inlet valves collects in the reservoirs and necessitates draining each reservoir periodically. This is done by opening the drain cocks located at the end of all tanks (optional pull-cable operated drain valves may be present). If the drain cock is opened in the end of the tank, there must be some air pressure in the system to assure proper drainage. Be sure to close the drain cocks after all moisture has been expelled.

On vehicles so equipped, the reservoir automatic drain valve ejects moisture and contaminants from the reservoir in which it is connected. It operates automatically and requires no manual assistance or control lines from other sources. The reservoir should be drained and the valve should be examined periodically to ensure that the drain passage is not obstructed.

## Operation

---

### *Brake Application*

Rapid successive brake applications and release, sometimes referred to as fanning or pumping the pedal, should be avoided. This is an inefficient way of slowing or stopping a vehicle and inefficient use of air pressure. It also defeats the proper operation of the ABS.

### Parking Brake



**Under no circumstances should the spring brake section of the spring and service brake chamber be disassembled. Disassembly will release a powerful spring, which could result in property damage, personal injury, or death.**

All vehicles with air brakes are equipped with spring brake chambers for parking. The parking system is operated manually by a single valve, which in the case of a tractor also controls the parking system on the trailer.

The purpose of this brake is to hold the vehicle in a parked position. The parking brake should not be used to brake the vehicle during normal driving.

To apply the parking brake, pull out control knob. To release the parking brake, push in the control knob.

It should be noted that upon loss of air pressure in both primary and secondary systems, partial spring brake application will occur prior to full automatic application of the parking brake control valve at 20 to 45 psi (138 to 310 kPa).

To release the parking brake after a low-pressure occurrence, recharge system to at least 70 psi (483 kPa) and push in the parking brake control. If the system cannot be recharged and the vehicle must be moved, the spring brake must be manually released (caged).



**Failure to comply with the following may result in property damage, personal injury, or death:**

- **Always chock the wheels when manually releasing the parking brakes, or the vehicle can roll.**
- **For towing, make sure the vehicle is securely connected to tow vehicle and tow vehicle parking brakes are applied before releasing the disabled vehicle's parking brakes.**
- **To ensure release of parking brake, always cage the spring in the brake chamber.**
- **Under no circumstances should the spring brake chamber be disassembled for the purpose of releasing the parking brake.**

In the event it is necessary to move the vehicle after an emergency application (before air pressure can be restored), the parking spring can be compressed mechanically to release the brake. A release stud spring caging tool is furnished with the brake chamber assembly. The release stud engages in the spring pressure plate and its nut is tightened to compress, cage the spring and release the brake.

Remove release stud assembly from carrying pocket.

Apply a light coat of antiseize to the threads of the release stud to avoid any unnecessary wear of the threads. Remove the access plug from the end of the spring chamber. Insert the release stud through the opening in the chamber and into the spring pressure plate.

Turn the release stud one-quarter turn to engage the tangs on the release stud into the slot in the pressure plate. Install the nut on the release stud. Be sure tang on release stud stays engaged with slot on pressure plate while installing the nut. Tighten the nut with a wrench to compress the spring.

### *Parking Brake Reset*

Charge spring brake chambers with air pressure. Loosen nut and remove the release stud and nut from the spring housing and re-install the access plug in the chamber opening. Re-install the release stud and nut in the carrying pocket on the brake chamber housing.

### *Parking Brake Alarm*

If the parking brake alarm sounds (**horn continuously blows when driver's door is opened**), press the service brake pedal. Then, after turning the ignition switch to the ON or ACC position, make sure that the parking brake is set. For a more detailed description of the alarm, see the **Parking Brake Alarm** in the **Electrical** section above.

### **Air Dryer**

The function of the air dryer is to collect and remove moisture and contaminants before the compressed air reaches the air

reservoirs. This protects the air system components from malfunctioning including blockage, corrosion, and freezing. For air tank draining requirements, refer to the Maintenance Instructions section as well as local regulations.

The air dryer is installed in the discharge line between the air compressor and the air system reservoirs. The air dryer includes a replaceable desiccant cartridge and oil blocking filter that is periodically serviced. It also may include a heater to prevent the discharge valve from freezing in cold weather.

### **Trailer Brake Hand Control**



**The hand control valve should never be used to apply the trailer brakes when the tractor and trailer are parked. Air pressure may leak from the system, and the vehicle could roll away, resulting in property damage, personal injury, or death.**

The trailer brake hand control is used to apply the trailer service brakes, independently of the tractor service brakes. The trailer brake hand control operates a valve that provides gradual control of air pressure applied to the trailer service brakes. The trailer service brakes can be fully or partially applied, but when in a partial position, can be overridden by pressing fully on the brake pedal.

To apply the trailer service brakes utilizing the hand control, move the lever clockwise (down). The further the handle is moved clockwise, the greater the air pressure applied to the trailer brakes. The trailer hand brake handle will remain in place with the desired brake pressure applied until the handle

## Operation

is manually moved. To release the trailer brakes, move handle counterclockwise (up) until trailer moves freely.

### Trailer Air Supply and Parking Brake Modular Controls

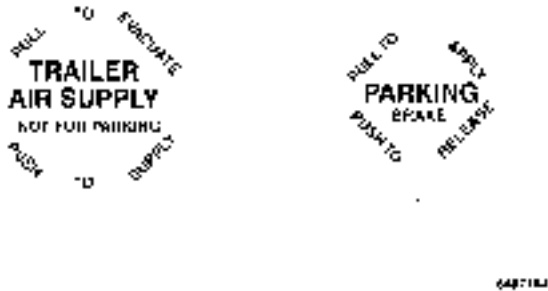

- TRAILER AIR SUPPLY (red octagonal knob)
- PARKING BRAKE (yellow diamond knob)

The PARKING BRAKE valve knob (yellow) should be pushed in first, after sufficient air pressure is built up (apply foot brake to prevent vehicle from rolling). The TRAILER AIR SUPPLY valve knob may then be pushed in.

The TRAILER AIR SUPPLY valve knob (red) and PARKING BRAKE valve knob will automatically pop out if the system pressure (both front and rear circuits) drops to 20 to 40 psi (138 to 276 kPa). The tractor protection valve will then close,

the tractor spring brakes will apply, and the trailer emergency system will be activated.

On vehicles equipped with the standard two valve system, the operation of one valve together with the other permits the operator to select the desired functions described below:

| Red Valve<br>(Trailer Air Supply) | Yellow Valve<br>(Parking Brake) | Function (Mode)   |
|-----------------------------------|---------------------------------|---|
| Out                               | Out                             | System Park   |
| In                                | Out                             | Trailer Charge  |
| In                                | In                              | Normal Running  |
| Out                               | In                              | Bobtail/Sliding<br>Fifth Wheel<br>Adjustment/Sliding<br>Trailer Tandems<br>Adjustment |

The PARKING BRAKE valve (yellow knob) controls the spring brakes on the tractor and when pulled out simultaneously causes the trailer supply valve to pop out, thus applying both tractor and trailer parking brakes. The trailer brakes may be independently released by pushing only the TRAILER AIR SUPPLY valve (red control) in.

The TRAILER AIR SUPPLY valve (red valve) delivers air to the trailer supply and will automatically pop out, shutting off the trailer supply if pressure is decreased to approximately 35 psi (241 kPa). For exact air pressure set-points, refer to the Service Manual.



**NOTE:** When attempting to readjust/slide the position of the tractor fifth wheel or the trailer's tandem axles with the tractor and trailer fully connected, leave the tractor's PARKING BRAKE pushed in and pull the TRAILER AIR SUPPLY out. This will apply the trailer's parking brakes and keep it stationary while the tractor is moved forward or reverse.

### **Parking Brake Indicator**



**Driving with the parking brakes applied can lead to excessive heat build up and fire resulting in property damage, personal injury, or death.**

The Parking Brake indicator is operated in conjunction with the parking brake. With the ignition switch on and the Parking brake set, the PARK indicator will illuminate. If the indicator does not illuminate with the Parking brake set, the indicator may be inoperative.

### **Bobtail Proportioning System**

Bobtail proportioning is available with tractor air brake systems (for export only with code 04092) with or without ABS or ABS/Traction Control Systems. The proportioning valve senses when trailer brakes are not connected to the vehicle air brake system, and automatically adjusts rear braking power when operating in the bobtail mode, then returns full braking power when a trailer is attached. When operating in the bobtail mode, bobtail proportioning provides more braking control and shorter stopping distances, particularly on wet and slippery road surfaces.

It should be noted that there is a noticeably different brake pedal feel on tractors with this feature while operating in the bobtail mode. Higher brake pedal efforts will be experienced by the driver than when in a brake system without bobtail proportioning.

## Operation

---

### Antilock Brake System (ABS)

#### General Information



Antilock brake systems are designed to enhance overall vehicle safety when a vehicle is driven within its safe operating limits. ABS cannot compensate for a vehicle that is being driven beyond the physical limits of control. Drivers operating an ABS equipped vehicle should employ safe driving practices and assume no additional driving risks. Failure to do so could result in property damage, personal injury, or death.



**Do not rely on the ABS system to interrupt vehicle engine brake on slippery road surfaces. Turn these devices off during hazardous driving conditions. Failure to follow this warning may cause wheel slippage and/or loss of vehicle control, which could result in property damage, personal injury, or death.**

The Antilock Brake System is a mandated feature added to the standard air brake system. It electronically monitors vehicle wheel speed at all times, and only engages when wheel lock is imminent. The standard air brake system controls normal braking when the ABS is not engaged.

### ABS Operation



**If the ABS warning indicator comes on, stopping distances may increase under certain braking conditions. Have the ABS system repaired immediately. Take every precaution to prevent wheel lockup, which could result in loss of vehicle control causing property damage, personal injury, or death.**

ABS requires no changes in driving practices. For the best stopping performance with or without ABS, modulate - do not pump - the brake pedal until the vehicle slows to desired speed or stops. Be aware that ABS on a towing vehicle does not control brakes on towed vehicles. Towed vehicles may or may not have ABS. ABS will prevent lockup of controlled wheels if you over-brake for existing road conditions. Optimum vehicle control for existing road conditions will be provided as a result of the ABS preventing wheel lockup at speeds above approximately 4 miles per hour. The ABS cannot provide any better braking and steering capability than the available road traction will permit. If the road is slippery it will take longer to stop than on a dry road. Steering maneuverability will be similarly limited. Vehicle speed must be reduced to compensate for the extended time and distance required to stop or slow the vehicle on slippery roads.

The wheel hubs carry exciter rings used by axle mounted sensors to transmit wheel speed information to the ABS electronic control unit located inside the cab. The control unit monitors and compares all wheel speed inputs to determine if any wheel(s) are about to lock. If wheel lockup is about to occur,

the control unit commands the appropriate modulator valve to adjust air pressure delivery to prevent wheel lockup.

### *ABS Self Check*

**Bendix ABS Checkout:** A yellow warning indicator on the instrument panel indicates the antilock system status. The indicator comes on and the system goes through an ABS self-checkout sequence each time the ignition is turned on. The system is working normally when ignition is turned on, indicator comes on, then flashes twice and remains on for several seconds before going out.

During the self-checkout, the modulator valves will cycle around the vehicle twice in the following pattern

1. Right Front
2. Left Front
3. Right Rear
4. Left Rear

A fault has been detected in the ABS if the warning indicator does not come on with ignition, does not flash, fails to go off or comes on again at any other time.

If over-braking causes wheel lockup on the rear drive axles while engine braking devices are in operation, the ABS will interrupt and disable the engine brake until the lockup situation has stopped.

If the ABS warning indicator on the instrument panel is lit, consult your nearest International® Truck service center for further assistance in maintaining and repairing your ABS.

### *Antilock Driving Tips*

**Brake just the way you always have.** Apply brakes as normal to stop in time. The ABS monitors the brake application electronically and automatically controls the brakes, much faster than a driver could do by pumping the brake pedal.

**Always remember that you are the most important factor to safe operation of your vehicle.** Steer clear of traffic, pedestrians, animals or other obstacles while you are in an emergency braking situation. The Antilock tractor and truck brake system will allow you to steer the vehicle during braking while it comes to a full stop. ABS is not an excuse to take unnecessary risks. Always drive carefully and stay a safe distance away from the vehicle in front of you.

**When driving with a single trailer, doubles, or triples:** Brake as necessary and watch your trailer(s) through your mirrors and correct steering as necessary to keep in straight lines.

**If only your tractor has ABS:** Use your tractor's ABS brakes. Steer clear of obstacles and watch the trailer through your mirrors to make sure it follows your tractor properly. Tractor ABS will help prevent tractor jackknife but will not prevent trailer swing out.

## **Automatic Traction Control (ATC) System**

### **General Information**

The Automatic Traction Control (ATC) feature is an available option on some models. Automatic Traction Control is an integrated addition to the Antilock Brake System. This system utilizes input from the individual wheel sensors to determine if

## Operation

---

drive axle wheel slip is occurring during vehicle acceleration. If drive axle wheel slippage is occurring, the Controller Relay initiates action to reduce engine power and/or to selectively apply rear brakes to transfer power from the slipping wheel to the opposite wheel. This enables the vehicle to gain momentum and move torque to road surfaces providing more traction. The system instantly blinks a dash indicator to advise the driver that wheel spin is occurring.

If wheel spin occurs at speeds above 25 mph (40 km/h), the dash indicator blinks and, using its link to the engine control module, the ATC reduces engine torque to a level suitable for the available traction. The brakes are not applied, even slightly, at any speed above 25 mph (40 km/h).

Both the Antilock Brake System and Automatic Traction Control are features added to the basic air brake system and the loss of either or both should in no way affect the basic brake system. ABS and ATC require no changes in driving style and it is best not to change your usual, careful driving habits. Other than during initial start-up, when the TRAC CTRL indicator flashes and then goes out, the ATC system should not be noticed until it's needed. Routine operation of the brakes and accelerator are unchanged.

### ATC System Check

At ignition turn-on, the TRAC CTRL indicator will illuminate steadily for 2.5 seconds and then turn off. If not, the system is defective or inoperative.

### ATC OFF ROAD or MUD/SNOW Switch

The optional ATC system comes equipped with one of two switches that perform the same functions of enabling and disabling the ATC system.

**NOTE:** Be sure to turn the ATC OFF ROAD or MUD/SNOW switch off when you return to a firm surface.

The function of this switch is to allow greater engine power and more wheel spin. When operating on soft road surfaces, place the OFF ROAD or MUD/SNOW switch in the ENABLE position. The switch indicator will flash slowly to indicate that this function has been selected, and will flash rapidly whenever ATC is operating to control excessive wheel spin.

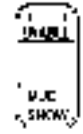
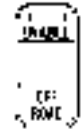

### Stability Control Systems – Bendix® RSP/WABCO RSC/Bendix ESP



**Vehicles equipped with Stability Control have reduced effectiveness when pulling double or triple trailers. Failure in understanding this warning could result in property damage, personal injury, or death.**



**Stability Control systems are designed to enhance overall vehicle stability by automatically reducing vehicle speed under certain conditions. Drivers operating a Stability Control equipped vehicle should employ safe driving practices and assume no additional driving risks. Failure to follow this warning could result in property damage, personal injury, or death.**

The optional stability control system provides the core ABS function as well as Automatic Traction Control (ATC) and Roll Stability functions.

**Core ABS Functions:** The core ABS system reduces wheel lock-up to help drivers maintain steering control while braking. Antilock Braking Systems (ABS) use wheel speed sensors, ABS pressure modulator valves, and an Electronic Control Unit (ECU) to control either four or six wheels of a vehicle. ECUs optimize slip between the tire and the road surface by monitoring individual wheel turning motion during braking.

**Roll Stability Functions:** The control system (RSP or RSC) helps to mitigate rollovers through advanced sensing, engine torque control, and automatic application of the vehicle brakes. RSP is an all-axle ABS solution that helps reduce vehicle speed by applying all vehicle brakes as needed, reducing the tendency to roll over. RSC is a rear-axle ABS solution that helps reduce vehicle speed by applying rear vehicle brakes as needed, reducing the tendency to roll over.

RSP or RSC focuses on reducing the vehicle's speed below the critical roll threshold during direction-changing maneuvers,

(such as at exit ramps) lane changing, cornering, or obstacle avoidance. It is most effective on dry, high-friction surfaces.

**Advanced Stability Functions (ESP):** This function enhances stability by sensing actual vehicle dynamics. ESP equipped vehicles add yaw control to the basic roll stability feature.

**Vehicle Stability Control Speed Reduction:** In the case of a potential roll event, the stability system will remove the throttle and quickly apply brake pressure to slow the vehicle combination below the threshold.

**Steering Angle Sensor (ESP only):** This sensor enables the advanced stability system to capture the driver's steering input and intervene if a yaw correction is needed. The sensor also provides the earliest indication of an increase in lateral acceleration that might cause a potential roll event. A steering angle sensor provides a greater stability margin than a vehicle that is not equipped with this sensor.

**Brake Demand Sensors:** The stability control system (RSP and ESP) was designed to supplement the drivers actions. By directly measuring driver brake demand, the system can transition seamlessly between driver-intended and system-intended braking pressure. For example, if in a certain maneuver, the system calculates 40 psi (276 kPa) is needed and the driver is only applying 20 psi (138 kPa), the system compensates automatically to deliver the needed 40 psi (276 kPa). If, however, during the same maneuver, the driver steps on the brake pedal quickly to apply a higher [above 40 psi (276 kPa)] braking level, the driver's braking input overrides the temporary change made by the system.

**ABS/Stability System Interaction:** With the ABS based stability control system, the ABS system is given "priority" at the

## Operation

---

wheel ends to manage wheel slip for optimal braking. The ABS system functions similarly whether the stability system or the driver applies the brakes.

### Towing Instructions



This vehicle may be equipped with (optional) dual tow hooks for recovery purposes only. Always use both tow hooks to prevent possible overloading and breaking of individual hooks. Failure to follow this warning could result in property damage, personal injury, or death.



Failure to comply with the following may result in property damage, personal injury, or death:

- Always chock the wheels when manually releasing the parking brakes, or the vehicle can roll.
- For towing, make sure the vehicle is securely connected to tow vehicle and tow vehicle parking brakes are applied before releasing the disabled vehicle's parking brakes.
- To ensure release of parking brake, always cage the spring in the brake chamber.
- Under no circumstances should the spring brake chamber be disassembled for the purpose of releasing the parking brake.

#### CAUTION

Remove tow hooks from their installed position in the front of the vehicle before operating the vehicle. Failure to do so could result in the tow hooks becoming unintentionally detached from the vehicle resulting in vehicle and/or engine component damage.

**NOTE:** Important factors to keep in mind when using tow hooks:

- use both tow hooks when retrieving vehicle
- use a slow steady pull, do not jerk on hooks
- tow hooks are not designed for towing, retrieval only

**NOTE:** The tow hooks must be removed to operate the tilt-away bumper.

Before moving the towed vehicle, check for adequate road clearance of vehicle components. International® Truck recommends unloading the towed vehicle prior to towing to reduce any abnormal loads to the vehicle components resulting from the towing procedures. Before towing, be sure to fully release the parking brake. The spring actuated type parking brake can be released by recharging the air system with at least 64 psi (441 kPa) of air. If brake system will not retain air pressure, then the spring brakes must be held in the released position (caged) manually. See **Parking Brakes**.

### Tow Hooks

Two removable front tow hooks are optional on International® ProStar®+ Series models. The tow hooks are inserted directly into the front suspension bracket when in use, and can be conveniently stored in the cab when not in use. Tow hooks provide a convenient attachment point from which to recover the vehicle in emergency situations.



1. Front Bumper
2. Tow Hooks
3. Receiver Portion of Front Suspension Bracket

**NOTE:** The optional tow hooks are stored in a bracket attached to the rear side of the seat bases on day cab models and in a plastic case under the bunk on sleeper models.

**NOTE:** Do not leave tow hooks in receivers when not in use.

Insert the tow hooks through the front bumper and into the receivers (tow hooks must have the point of hooks vertical while inserting into receiver). Push on each tow hook and rotate outward 90° to secure the hooks in the locked position. The point of each tow hook is pointed outboard on the truck to prevent damage to the bumper during towing.

### Towing Vehicle With Front Wheels Suspended

#### **CAUTION**

To prevent transmission damage, vehicles should not be towed even short distances without suspending rear wheels or removing the axle shafts or propeller shaft.

In the event the chassis is equipped with tandem axle and the vehicle is to be towed from the front, the forward rear axle may be raised to clear the road surface and secured to the frame by chains or U-bolts, allowing only rear axle to contact road surface. Axle shafts must be removed from rear axle assembly. The wheel hub ends must be covered to prevent loss of axle lubricant and entrance of contaminants. Use extreme care in securing the chains or U-bolts to prevent possible damage of brake lines, hoses or other components.

When it is necessary to tow a vehicle with the front wheels suspended, extra precautions must be taken to avoid transmission or differential damage. Proceed as follows.

Remove axle shafts from axle assembly to prevent the wheels from driving the differential and the transmission. The wheel hub ends must be covered to prevent loss of axle lubricant and entrance of contaminants. If axle shafts are not removed, removal of propeller shafts at rear axle will be required.

### Towing Vehicles With Driver Controlled Differential Lock

#### *Removing Axle Shafts Before Towing*

#### **CAUTION**

To prevent differential and/or transmission damage, vehicles that must be towed to a service facility with the drive axle wheels on the ground, it is necessary to remove the axle shafts before the vehicle is towed.

#### **CAUTION**

Do not use a chisel or wedge to loosen axle shafts and dowels. The chisel or wedge can damage hub, axle shafts and oil seals if used.

**NOTE:** One of the axle shafts has two sets of splines. One set to engage with differential side gear and one set to engage with shift collar for the differential lock. It may be necessary to rotate shaft slightly to align side gear spline teeth with clutch collar teeth in order to remove axle shaft.

1. Shift main differential to the locked (engaged) position.

Applicable RR DIFF or FR DIFF ENGAGE indicator must be illuminated in instrument panel gauge cluster to validate DIFF LOCK is FULLY engaged and axle shaft can be removed. Failure to fully engage axle DIFF LOCK will allow DIFF LOCK shift collar to fall slightly and block, or temporarily resist axle shaft reinsertion.

2. Remove cap screws and washers or stud nuts and washers from flanges of both axle shafts.



3. Loosen tapered dowels in flanges of both axle shafts by holding a 1-1/2 inch diameter brass drift or hammer against axle shaft center and hitting it with a five to six pound hammer.
4. Remove tapered dowels and both axle shafts from axle assembly.
5. Assemble a cover over openings of both wheel ends to prevent loss of lubricant and keep dirt from the wheel bearing cavities.

### *Installing Axle Shafts*

1. Remove covers from wheel ends.
2. Shift differential lock to the locked (engaged) position.

Applicable RR DIFF or FR DIFF ENGAGE indicator must be illuminated in the instrument panel gauge cluster to validate DIFF LOCK is FULLY engaged and axle shaft can be removed. Failure to fully engage axle DIFF LOCK will allow DIFF LOCK shift collar to fall slightly and block, or temporarily resist axle shaft reinsertion.

3. Install right-hand and left-hand axle shafts as follows:
  - a. Place gaskets on wheel hub studs.
  - b. Push right-hand axle shaft into wheel end and housing until shaft stops against differential shift collar.
  - c. Push axle shaft further into housing until shaft stops against differential side gear.
  - d. Push down on axle shaft flange and rotate shaft until splines of shaft and side gear are engaged.
  - e. Push axle shaft completely into housing until axle shaft flange and gasket are flush against wheel hub.
  - f. Install left-hand axle shaft and gasket into wheel end.
4. If tapered dowels are required, install them at each stud and into flange of axle shaft. Use a punch or drift and hammer if needed.
5. Install fasteners and tighten to correct torque value. Refer to the appropriate Service Manual Section.

### **Towing Vehicle With Rear Wheels Suspended**

#### **CAUTION**

**To prevent damage to cab roof or air deflector when towing the vehicle backwards (rear wheels suspended) the air deflector must be removed.**

## Operation

---

Whenever possible, it is preferable to tow a disabled vehicle from the rear by raising the rear of the chassis by the rear axles.

When towing a vehicle with rear of the chassis suspended, the front wheels must be locked in the straight ahead position.

### Tractor-Trailer Connections



**Whenever possible, make trailer connections while standing on the ground. Provide adequate lighting of working areas. Inclement weather and accumulated road contamination deposits on handholds and stepping surfaces require extra care to prevent slips and falls which could cause personal injury or death.**

**Do not climb on the back of a tractor unless it has been provided with a deck plate and handholds. Use a three-point stance when climbing up and down from a deck plate. Do not jump from vehicle.**

### Connecting/Disconnecting a Trailer to a Vehicle with Air Suspension

The Air Suspension has a dump valve system option (Code 14899) that permits exhausting air from the suspension system, thus lowering the frame when connecting, disconnecting, or

loading the trailer. The vehicle speed must be below 5 mph (8 km/h) before the switch will operate the valve.

When connecting to a trailer, switch the SUSP/DUMP switch, located on the instrument panel, to the DUMP position and air will exhaust from the suspension system lowering the tractor. This will permit backing under the trailer without undue loading of suspension system. After making the connection to the trailer, return the switch to the SUSP position, then raise landing gear.

When disconnecting the trailer, lower the landing gear, disconnect the brake hoses and rear light connectors from the trailer, and pull the release lever on the fifth wheel. Slowly pull the tractor forward just far enough to release the king pin from the fifth wheel and stop. Switch the SUSP/DUMP switch to the DUMP position and pull the tractor away from the trailer.

The SUSP/DUMP switch must be returned to the down SUSP position before operating with a trailer or operating in the bobtail mode.

### Fifth Wheel Operation



**Always follow the fifth wheel manufacturer's instructions for hooking and unhooking as well as sliding the fifth wheel. Failure to follow this warning could result in property damage, personal injury, or death.**



**When using an assistant to reposition a sliding fifth wheel, the driver must be ready to stop as soon as the fifth wheel moves to the desired position. The assistant must keep feet, hands and body clear of the vehicle's tires and other moving parts to prevent personal injury or death. The driver must not begin to move the vehicle until the assistant is clear and signals the driver to move the vehicle.**

*Fifth Wheel Slide Switch (Optional)*

An optional Fifth Wheel Slide switch may be present. This switch allows the operator to electronically unlock the fifth wheel to allow it to be moved forward or backward and re-lock it once the desired position is attained.



To unlock the fifth wheel, press the top portion of the switch in. The switch indicator will illuminate steadily when the fifth wheel is unlocked.

**NOTE:** The fifth wheel cannot be unlocked above a preset speed (normally 2 mph [3 km/h]). Attempting to unlock the fifth wheel at any higher speed will cause the switch indicator to flash slowly (once per second). The fifth wheel lock automatically engages if it has been unlocked and the vehicle speed exceeds the preset value.

To lock the fifth wheel once the desired position is reached, press the lower portion of the switch. The switch indicator will turn off when the fifth wheel is locked.

**NOTE:** A fast flashing (twice per second) switch indicator signifies a problem in the fifth wheel lock system.

*Hook-Up*

1. Fifth wheel jaws must be opened fully.
2. Tilt fifth wheel back to prevent body damage when tractor is backed under trailer.
3. Block trailer wheels and be sure trailer spring brakes are adjusted and applied. Never chase a trailer.
4. Make sure brake hoses and light cords are clear of the fifth wheel.
5. Back tractor squarely under trailer, engaging fifth wheel jaws on trailer kingpin. Always back slowly, making sure trailer is neither too high nor too low. Avoid backing under trailer from an angle.
6. Connect service and parking brake hoses and trailer light connector. Refer to the Warning located in the **Tractor-Trailer Connections** information. Use a three-point stance when connecting and disconnecting trailer.
7. Inspect fifth-wheel jaws to be sure they have closed on trailer king pin and the trailer plate is resting securely on the fifth wheel.
8. Be sure the coupler release lever is in the locked position.

## Operation

---

9. Charge trailer brake system. Set trailer brakes, either with the hand valve or tractor protection valve. Pull against trailer for an additional check of hook-up. Do not pull hard enough to damage or strain the equipment.
10. Set tractor parking brakes and fully raise trailer landing gear. Refer to **Brakes** segment of this section for Operation of Parking Brakes and Trailer Brakes.
11. Check operation of all trailer lights and correct faulty lights.

### Un-Hook

1. Try to keep tractor and trailer in straight line.
2. Apply tractor and trailer parking brakes.
3. Lower trailer landing gear, making sure it is on solid, level ground. The weight of trailer must be on landing gear.
4. Block trailer wheels.
5. Disconnect brake hoses and light cords. Be sure hoses and cords are clear.
6. Pull coupler release lever to disengage fifth wheel jaws.
7. Release tractor parking brakes.
8. Pull out from trailer slowly, allowing landing gear to take load gradually.

### Fifth Wheel Jaw Unlock Control

Your vehicle may be equipped with an optional Fifth Wheel Jaw Unlock feature. A guarded switch mounted in the cab allows the operator to unlock the fifth wheel jaw from inside the vehicle. There are two available versions for the system, with monitoring or without monitoring. The version with monitoring capabilities includes additional indicators to show the driver fifth wheel jaw status.

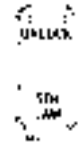

**NOTE:** Fifth Wheel Jaw Unlock is only operational when vehicle is stationary, parking brake is set, and ignition switch is in the RUN position.

**NOTE:** Outside (roadside), mechanical jaw release mechanism is still operable regardless of in-cab control.

To unlock the fifth wheel jaw, depress and **hold** the UNLOCK FIFTH JAW switch. If the switch is only pressed **momentarily** jaw unlock **will not occur**. A continuous tone alarm will sound while the jaw is unlocking. The continuous tone will then change to a repetitive beep indicating jaw unlocking is complete. The red indicator in the switch will turn on when jaw unlocking is complete. Release the UNLOCK FIFTH JAW switch and release the parking brake to silence the alarm. The red indicator will then turn off. If the red indicator flashes fast, this indicates a fifth wheel control system error or failure. If the red indicator flashes slowly, this indicates an interlock problem, (e.g. parking brake not set).

**NOTE:** If the continuous tone alarm shuts off before the repetitive beep is heard, jaw unlocking was incomplete.

### *Fifth Wheel Jaw Monitoring*

The optional fifth wheel jaw monitoring feature is an electronic jaw lock indicator system with two indicators to show fifth wheel jaw status to the driver.

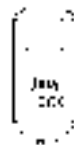

One indicator, JAW LOCK, has a green that illuminates when the trailer is fully locked onto the fifth wheel. The other indicator, JAW UNLOCK, has a red that illuminates when the trailer is not fully locked onto the fifth wheel. If neither indicator is illuminated, this indicates the jaw is unlocked and the tractor is not connected to a trailer and is in Bobtail mode. If the JAW UNLOCK indicator is flashing, this indicates the jaw is locked and the trailer is not connected to the fifth wheel. If both indicators are flashing, this indicates a system error or failure. Both indicators will illuminate briefly when the key is turned to the ON position as a check of function.

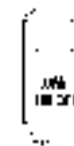



## SECTION 7 — MAINTENANCE INSTRUCTIONS

### Introduction



If the owner/operator of the vehicle is a skilled technician and intends to perform the vehicle maintenance and servicing, he/she is strongly urged to purchase and follow the appropriate International® service manuals or Diamond ISIS® CD-ROM. Ordering information is included at the back of this manual. Failure to properly perform maintenance and servicing procedures could result in property damage, personal injury, or death.

Your vehicle has been engineered and manufactured to provide economical service. However, it is the owner's responsibility to see that the vehicle receives proper care and maintenance to assure high performance.

Quality International® service parts are available through your International® Truck Dealer. If International® service parts are not used, the owner must make sure that the parts used are equivalent to International® service parts.

As with any vehicle, care should be taken to avoid being injured when performing maintenance or repairs or making any checks. Improper or incomplete service could result in the vehicle not working properly, which in turn, may result in personal injury or damage to the vehicle or its equipment. If you have any question

about performing some service, consult your International® Truck dealer or have the service done by a skilled technician.

### Maintenance Guidelines



Failure to perform proper maintenance and service could result in property damage, personal injury, or death.



Making modifications to any part, component, or system of the vehicle, can adversely affect the quality and reliability of your vehicle and must be prevented. Modifications to systems could result in property damage, personal injury, or death.



Use only genuine International truck service parts. The use of inferior parts can adversely affect the quality and reliability of your vehicle, which could result in property damage, personal injury, or death.



To prevent property damage, personal injury, or death, take care when performing any maintenance or making any check or repair. Some of the materials in this vehicle may also be hazardous if used, serviced, or handled improperly. If you have any questions pertaining to the service, have the work done by a skilled technician.



To prevent property damage, personal injury, or death when servicing the vehicle, park on a flat level surface, set the parking brake, turn off the engine, and chock the wheels.



Always disconnect the ground battery terminal first, then the positive cable. When reconnecting the battery cables, connect the positive cables first, and then reconnect the negative cables. Failure to follow this warning may result in a direct battery short which is a fire or explosion hazard which could result in property damage, personal injury, or death.

### CAUTION

To prevent damage to electrical components during electric welding operations, follow these cautions: Prior to electric welding, disconnect any negative and positive battery cables that connect the batteries to the vehicle. Be sure the detached connectors are not touching the vehicle. If welding close to an electronic component, temporarily remove that component. Attach the welder ground cable as close as possible to the part being welded.

#### When servicing your vehicle always:

1. Turn off the ignition switch, unless the procedure calls for a running engine.
2. Set the parking brake and chock the wheels.
3. Use support stands, not a jack, whenever you must be under a raised vehicle.
4. Do not smoke.
5. Wear safety glasses for eye protection.
6. Operate engine only in a well-ventilated area.
7. Do not work on brakes or clutch unless proper precautions are taken to avoid inhaling friction material dust.
8. Do not wear loose clothing, hanging jewelry, watches or rings. Tie up long hair and avoid rotating machinery.
9. Avoid contact with hot metal parts; allow hot components to cool before working on them.



10. Correct any problems that were revealed during inspection prior to operating the vehicle.

### Supporting Your Vehicle for Service



**Always use floor stands to support the vehicle before working under it. Using only a jack could allow the vehicle to fall resulting in property damage, personal injury, or death.**

When performing service repairs on a vehicle, first:

1. Park vehicle on level concrete floor.
2. Set parking brake and/or block wheels to prevent vehicle from moving.
3. Select jack with a rated capacity sufficient to lift the vehicle.
4. Raise vehicle with jack applied to axle. (**Do not** use bumper as a lifting point.)
5. Support vehicle with floor stands under axle(s).

If axle or suspension components are to be serviced, support vehicle with floor stands under frame side members, preferably between the axles.

### Chassis Lubrication

New vehicles are lubricated at the factory. After the vehicle is placed in operation, regular lubrication and maintenance intervals, based on the type of service and road conditions, should be established. The loads carried, speed, road and weather conditions all contribute to the frequency of lubrication intervals. Thorough lubrication and maintenance at the specified intervals will insure Outstanding Life Cycle Value and will reduce overall operating expense.

In some types of operation, and where operating conditions are extremely severe (such as in deep water, mud or unusually dusty conditions), the vehicle may require re-lubrication after every 24 hours of operation.

Only lubricants of superior quality, such as Fleetrite® lubricants, should be used. The use of inferior products will reduce the service life of the vehicle or result in failure of its components. Navistar, Inc. recommends the use of Fleetrite® lubricants and OEM original equipment parts.

The lubrication intervals specified should be performed at whatever interval occurs first, whether it is miles (kilometers), hours, or months.

These intervals are provided in **SECTION 8 — MAINTENANCE INTERVALS AND SPECIFICATIONS**

### Air Conditioning Service Checks

Have your air conditioning system serviced each spring. The refrigerant charge, cleanliness of condenser-evaporator cores, cab filter, and belt condition are essential to air conditioning performance.

Remove the fresh air filter(s) once each season and check for dirt, lint, etc. Replace if necessary. Vehicles operating in unusually dusty conditions may require inspecting and replacing the air filter(s) more often.

To reduce costs, the filter(s) may be carefully power-washed with a soap solution and reused. Be sure to wash and rinse both sides and be sure to keep the spray head at least six inches away from the filter to prevent damage.

Correct airflow may be restored by either replacing the filter(s), which can be done without tools, or by cleaning the filters.

### HVAC Filters

**NOTE:** There are three possible cab HVAC filter configurations; top access, side access and front access HVAC filter housings.

### Side Access HVAC Filter



1. Filter Access Door
2. Air Intake Housing

### Cab HVAC Filter Replacement – Side Access

1. Unlatch and remove filter access door.
2. Remove filter by pulling filter out of air intake housing.
3. Install new filter by sliding filter into air intake housing.
4. Install filter access door and latch in place.

### Front Access HVAC Filter

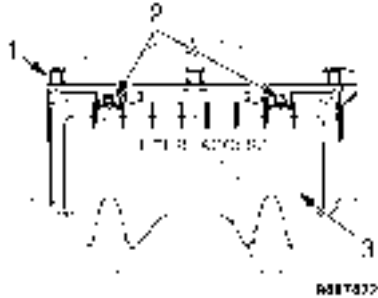

1. Air Intake Housing
2. Screws
3. Filter Access Door

### Cab HVAC Filter Replacement – Front Access

1. Turn screws counterclockwise one quarter turn and open filter access door.
2. Remove filter by pulling filter out of air intake housing.
3. Install new filter into air intake housing.
4. Close and secure filter access door by turning screws clockwise one quarter turn.

### Recirculation Filters

The recirculation filters are mounted on the left and right sides of the HVAC unit which is located in-cab under the left side dash.

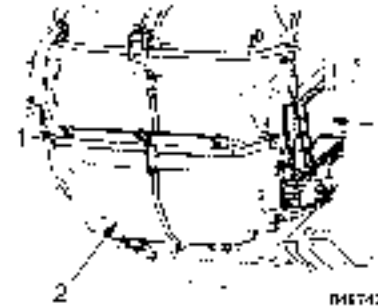

1. Recirculation Filter
2. HVAC Unit

### Cab HVAC Filter Replacement

1. Remove by gently pulling filter away from HVAC unit.
2. Install new filter onto HVAC unit.

## Maintenance Instructions

---

### Sleeper HVAC Filter

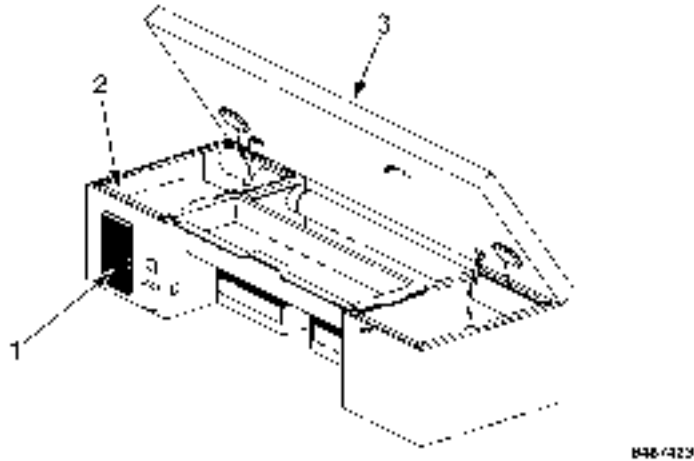

1. Air Intake
2. Filter
3. Lower Bunk Platform

### Sleeper HVAC Filter Replacement

1. Raise lower bunk platform.
2. To avoid damaging the filter, carefully grasp the end of the filter and pull it up and out.
3. Slide a new (or cleaned) filter fully into the slot by pressing down on the outer two edges of the filter's top surface.

4. Close lower bunk platform.

## Axles

### Front Axle

#### *Inspection and Lubrication*

Check to make sure that the front axle mounting U-bolts, attaching or mounting bolts and nuts are securely tightened. Loose or misaligned front axles will affect vehicle alignment, front tire wear, and handling.

Re-torque the U-bolt nuts after the first 1,000 miles (1,600 km) and every 36,000 miles (58,000 km) thereafter.

Observe the following when checking the front axle for damaged, binding, or worn parts, and adequate lubrication:

- Kingpin wear inspection requires that no weight is on the tires.
- Kingpin and kingpin bushing lubrication requires that the vehicle weight is off tires and the front wheels be turned fully to the left or right prior to installing grease distribution.
- Kingpin thrust bushing lubrication requires that the vehicle weight is resting on the tires.
- Power grease guns may be used: however, a hand-pumped grease gun is recommended for optimal grease distribution within each component joint.

- Inspect, lubricate and adjust the wheel bearings at regular intervals. Refer to **SECTION 8 — MAINTENANCE INTERVALS AND SPECIFICATIONS** for the correct intervals, lubricants, and torques.

### *Normal Maintenance*

During operation, the air and oil inside the hub/wheel cavity expands. It is normal for a mist of oil to be present on the outside of the hubcap around the vent slit or hole. Over time, if not wiped off, this film may collect dust and appear unsightly. If the entire face and end of the hubcap become wet with oil, investigate the cause. Refer to the Service Manual for repair procedures.

Routinely clean the hubcap to ensure that the lubricant level can be easily observed through the clear window as intended. In situations where the window is clean on the outside but discolored on the inside, check the lubricant level by removing the rubber fill/vent plug and insert a finger into the hole.

The specified lubricant level for International® clear window type hubcaps is from the minimum line to 5/16 inch (.8 cm) above the minimum line.

If the lubricant level suddenly drops dramatically below the minimum level, see the Service Manual for diagnostic procedure.

### *Alignment*

Maintaining front axle alignment is very important to achieving maximum tire life and vehicle control. Inspecting steer axle tires in the first 3,000 (4828 km) to 10,000 (16,094 km) service miles will generally show if tires are wearing normally.

- Rapid outside shoulder wear on both tires indicates too much toe-in.
- Rapid inside shoulder wear on both tires indicates too much toe-out.
- Excessive wear on the inside or outside of one steer tire but not the other can indicate a toe-in or toe-out condition coupled with a misaligned front or rear axle.
- Pulling to the right or left can indicate misalignment of the front or rear axle, unequal tire pressures, or a damaged/mismatched tire.

Refer to the **Tires** subsection for additional related information.

### **Rear Axle**

#### *Inspection and Lubrication*

Check to make sure that the rear axle mounting U-bolts, attaching or mounting bolts and nuts are securely tightened. Loose or misaligned rear axles will affect vehicle alignment, tire wear, and handling. Refer to **SECTION 8 — MAINTENANCE INTERVALS AND SPECIFICATIONS** for torque specifications.

Check the rear axle oil level. Proper oil level minimizes gear wear, heat and damage to the wheel bearings and seals. The oil level should be at the lower edge of the level inspection hole when the vehicle is on level ground. Add oil as necessary.

Refer to **SECTION 8 — MAINTENANCE INTERVALS AND SPECIFICATIONS** for additional information.

## Maintenance Instructions

---

### Locking Differential

Vehicles which have a locking differential have the appropriate operators manual supplied with the vehicle. Refer to this manual for maintenance checks.

### Brakes

#### General Information



**To prevent personal injury or death, prevent breathing brake lining fiber dust. Always use a respirator while performing brake maintenance. Follow precautions listed below.**



**Always check and maintain brakes in proper condition and adjustment. Out of adjustment brakes could cause reduced braking ability and result in property damage, personal injury, or death.**

All new International® vehicles use nonasbestos brake linings. However, exposure to excessive amounts of brake material dust may be a potentially serious health hazard.

Follow these precautions:

- Always wear a respirator approved by National Institute of Occupational Studies of Health (NIOSH) or Mine Safety and Appliance (MSA) during all brake service procedures. Wear the respirator from removal of the wheels through assembly.
- **Never** use compressed air or dry brushing to clean brake parts or assemblies.
- Clean brake parts and assemblies in the open air. During disassembly, carefully place all parts on the floor to avoid getting dust into the air. Use an industrial vacuum cleaner with a HEPA filter system to clean dust from the brake drums, backing plates, and other brake parts. After using the vacuum, remove any remaining dust with a rag soaked in water and wrung until nearly dry.
- **Never** use compressed air or dry sweeping to clean the work area. Use an industrial vacuum cleaner with a HEPA filter system and rags soaked in water and wrung until nearly dry. Dispose of used rags with care to avoid getting dust into the air. Use an approved respirator when emptying vacuum cleaners and handling used rags.
- **Worker cleanup.** Wash your hands before eating, drinking, or smoking. Vacuum your work clothes after use and then launder them separately, without shaking them, to prevent fiber dust from getting into the air.

### Air Brakes

#### *Inspection and Adjustment*



Always chock the wheels when manually releasing the spring brakes, or the vehicle could roll causing property damage, personal injury, or death.



Under no circumstances should the spring brake section of the spring and brake chamber be disassembled. Disassembly will release a powerful spring which could result in property damage, personal injury, or death.



**Brake Automatic Slack Adjusters (ASA's) should not need to be manually adjusted in service. ASA's should not routinely have to be adjusted to correct excessive push rod stroke. Excessive stroke indicates that a problem exists with the foundation brake, ASA, brake actuator, other brake system components, or their installation or adjustment.**

**In the event that a manual adjustment must be made (although this should not be a common practice), a service appointment and full foundation brake, ASA, and other brake system component inspection must be conducted as soon as possible to ensure the integrity of the overall brake system prior to returning the vehicle to service.**

**Failure to follow this warning may result in property damage, personal injury, or death.**

A regular schedule for periodic cleaning, lubrication, adjustment and inspection should be established, based on the type of vehicle operation. It is difficult to predetermine an exact maintenance interval (time or mileage), since vehicles will be used in a wide variety of applications and conditions. If you are uncertain of the proper schedule and procedures for your vehicle, contact your International dealer.

Periodic checking of push rod travel or brake adjustment is essential for good braking. Push rod travel should be checked every service interval to determine if adjustment is necessary.

## Maintenance Instructions

---

Brake chamber push rods on original equipment chambers now incorporate an overstroke indicator (an orange paint marker near the base of the push rod) to aid adjustment checks. If the push rod is clean and the orange marker can be seen protruding from the chamber when the brakes are applied, the brakes require adjustment.

Slack adjusters should also be checked to ensure proper operation of the adjuster mechanism at every interval. Push rod travel should be less than the maximum allowed stroke without brakes dragging.

Inspect brake linings every maintenance interval. When brake shoes (or pads) are worn to within 1/16 inch (1.6 mm) of rivets (or backing plates), as indicated by a line or other feature on the edge of most brake shoes (or pads), brake shoes (or pads) must be replaced.

This inspection or adjustment should only be performed by qualified service personnel and must be in accordance with instructions provided by the Service Manual.

**NOTE:** Do not overlook the brakes on the trailer either. Brake condition on a trailer is just as important as the tractor. Proper brake balance on trucks and tractor trailers is essential for good braking.

At least once a year, the entire brake system must be inspected by a trained mechanic. Deteriorated components or components worn outside of specifications must be replaced. Check:

1. Rubber components for condition, cracks, tears, wear, missing components, etc.

2. Condition of drums, brake chambers, and slack adjusters for wear, corrosion, maladjustment, cracks, missing components, etc.
3. For air leaks. **No air leakage is permissible.** Also, check for air leaks with parking brake disengaged and wheels chocked.
4. Hose or pipes for rust, damage, deterioration.
5. Proper operation of service, parking, and trailer brake controls.
6. The condition and full insertion of the ABS wheel speed sensors, wiring, and connectors.
7. Proper ABS wheel speed sensor-to-exciter teeth gap.

### Air Dryer

#### *General Information*

**NOTE:** The use of an air dryer does not eliminate the need to periodically drain the air tanks.

The air dryer removes humidity (water), air compressor oil, and dirt from the incoming compressed air, thus protecting the air system against deterioration and restriction.

The air dryer is installed between the air compressor discharge line and the air tanks. The air dryer has a desiccant cartridge and a filter which is serviced as an assembly. Moisture from the air collects on the desiccant and is automatically discharged.

Life and performance of the air dryer depends on usage, air humidity levels, environmental temperatures, air compressor oil



control, and desiccant quantity. Regularly check the desiccant, purge valve and air dryer heater performance.

### *Desiccant Filter*

Open reservoir drain valves and check for presence of water. Small amounts of water due to condensation is normal. If the wet, primary, or secondary tanks are collecting an abnormally high amount of water between regular air tank drain intervals, replace the air dryer desiccant.

The air dryer desiccant replacement interval may vary; it is generally recommended that the desiccant be replaced every 12 months for small air dryers, like the Bendix AD-IP®, or every 24 months for large air dryers, like the Bendix AD-9® or Bendix AD-IS®. If experience has shown that extended or shortened life has resulted for a particular installation, then the interval should be increased or reduced accordingly.

### *Purge Valve*

Check that the purge valve opens and expels moisture when the air governor shuts off the air compressor. Air should escape rapidly and then quickly stop. If the purge valve does not open or you can hear a slight audible air leakage past the valve for longer than 30 seconds, the valve may be sticking and should be rebuilt. Purge valves may also stick if the air dryer heater has failed and ice is clogging the valve.

### *Heater*

Check that the air dryer heater activates at temperatures below freezing. With the vehicle in a cold environment and before the

engine is started, turn on the ignition and touch the air dryer housing. It should be warmer than other metallic items on the vehicle. If some warmth cannot be felt, it may indicate that the heater element or the wiring powering it should be serviced.

### **Air Reservoir/Tanks Moisture Draining**

Moisture taken in with the air through the compressor inlet valves collects in the air tanks. The wet tank is the first tank to receive air from the air dryer and therefore collects most of the remaining moisture that was not removed by the air dryer. Drain the wet tank reservoir every day at the end of the trip. Drain the primary and secondary tanks periodically. Periodically, manually drain each reservoir by opening the drain cock located either on the bottom of the tank or in the end of the tank. Make sure the drain passage is not plugged. For ease of draining, some or all air tank drain valves may be equipped with optional pull cords. There must be some air pressure in the system to ensure proper drainage. Close the drain cocks after all moisture has been expelled. Drain the wet tank daily at the end of each trip to purge collected water and prevent ice formation inside the tank when the vehicle is shut off in cold weather. If you are unsure which tank is the wet tank, drain all tanks daily.

On vehicles equipped with automatic drain valve(s), moisture and contaminants are automatically removed from the reservoir to which it is connected. It operates automatically during each compression cycle and requires no manual assistance or control lines from other sources.

The Bendix AD-IS® air dryer has an integral wet/purge tank which automatically purges itself and the desiccant of collected water at the end of each compressor cycle.

## Maintenance Instructions

---

### ABS Connections and Sensors

Periodically, push together the ABS wiring connections to ensure they are fully-seated. Press the wheel speed sensors into their mounting collars to ensure they are fully-seated.

### Cab

#### Care of Vehicle

##### *Washing and Waxing*

Frequent and regular washing will lengthen the life of your new vehicle's painted finish and bright metal trim.

Wash your vehicle often with warm or cold water to remove dirt and preserve the original luster of the paint. Never wash the vehicle in the direct rays of the hot sun or when the sheet metal is hot to the touch, as this may cause streaks on the finish. Do not use hot water or strong soaps or detergents, as this may etch the paint or exposed metal/bright surfaces. Do not wipe off dirt when the surface is dry, as this will scratch the paint or exposed metal/bright surfaces.

Always make sure that steps and grab handles are clean and free of road grime, grease, ice, and other debris.

Prior to using any wax or polish, the vehicle must be thoroughly washed to avoid scratching the finish.

##### *Bright Metal Care*

To preserve the bright look of your vehicle's trim (grilles, bumpers, etc.) use only mild detergents and lukewarm water

for cleaning. Damage to these parts can occur if cleaning solutions having excessive acidity or alkalinity (pH) are used. Also, the higher the solution temperature ranges, the more caustic the cleaner's chemical compounds become. However, if high-pressure washing equipment and washing compounds are used, satisfactory results can be achieved, if the solution has a pH value between 4 and 8 and the temperature does not exceed 160°F (71°C). Solutions that are more acidic or more alkaline will attack the metallic coating.

If you are having difficulty with your washing compound, contact your local supplier for the acidity/alkalinity (pH) specification.

A nonabrasive chrome cleaner may be used sparingly to clean the bright metal. Do not use steel wool. Use of automobile wax or polish on bright metal usually will restore the original brightness.

##### *Upholstery Care*

Use a whisk broom and vacuum cleaner to remove loose dust and dirt from upholstery and floor. Vinyl and woven plastic upholstery can be washed with warm water and mild soap. Remove soap residue and wipe dry. If commercial cleaners are used, follow instructions supplied with cleaner.

##### *Exposed Rubber and Unpainted Plastic Parts*

To better protect plastic surfaces from fading, use Meguiar's #40 vinyl and rubber cleaner/conditioner. Spread evenly with sponge or towel and allow to penetrate. Buff off excess product with clean cloth.

### Clutch

#### Pedal Free Travel

All International® ProStar®+ Series vehicles are equipped with pull type clutches. If a non-self-adjusting clutch (clutches other than the Eaton Solo series) was selected, free pedal must be checked each time the vehicle chassis is lubricated. If free pedal is less than 1/2 inch (13 mm), the clutch must be adjusted. Contact your International® Truck dealer for proper clutch adjustment procedures. After proper clutch adjustment, clutch free pedal should be between 1.25 and 1.75 inch (32 mm and 44 mm) and the release bearing should contact the clutch brake with 1/2 to 1 inch (13 mm to 25 mm) of clutch pedal travel remaining. Free pedal and clutch brake should be adjusted by lengthening (increases free pedal and decreases clutch brake squeeze) or shortening (decreases free pedal and increases clutch brake squeeze) the horizontal rod if outside of this specification. Contact your International® Truck dealer for proper linkage adjustment procedures.

**NOTE:** Proper clutch and linkage adjustment will provide adequate clearance between the release yoke fingers and the release bearing as well as between the release bearing and the clutch brake for proper operation. Improper adjustment may cause improper clutch operation, reduce clutch life, and may void the clutch warranty.

Clutch cross-shafts and throw-out bearings must be lubricated each time the vehicle chassis is lubricated to ensure smooth clutch activation and long life.

All new International® ProStar®+ vehicles use non-asbestos clutch linings. However, exposure to excessive amounts of clutch material dust (whether asbestos or non-asbestos, fiberglass, mineral wool, aramid, ceramic or carbon) is a potentially serious health hazard.



**To prevent personal injury or death, prevent breathing clutch lining fiber dust. Always wear a respirator when doing clutch lining maintenance.**

Persons who handle clutch linings should follow the same precautions as outlined for handling brake linings.

#### Hydraulic Clutch

Your vehicle is equipped with a hydraulic clutch actuation system. The reservoir is located just below the cowl, left of center on the firewall.

#### CAUTION

**To prevent vehicle and/or engine component damage, use only approved hydraulic clutch fluid (DOT 3 or DOT 4 brake fluid) in the clutch hydraulic system. Do not mix different types of brake fluid. The wrong fluid will damage the rubber parts of the system, causing loss of clutch function.**

### CAUTION

To prevent vehicle and/or engine component damage, do not allow the fluid level in the reservoir to go below the MIN line. If too much air enters, the hydraulic system will not operate correctly, and the clutch could be damaged.



1. Reservoir
2. Cap

If the fluid level is below the MIN line, remove cap and fill the reservoir with DOT 3 or DOT 4 brake fluid until the level reaches the MAX line.

## Electrical

### Batteries

Battery life and performance varies greatly depending on duty cycle. Conditions such as short runs between starts, low ambient operating temperatures, using battery current without the engine running, and vibration will reduce battery life. Battery life is also affected by the condition of interrelated components, such as alternators, battery cables, connections, engine startability, starter, etc. To maximize battery life, it is important to keep electrical components, battery boxes, and the engine in top condition and to minimize or eliminate electrical loads when the engine is not running.

Battery life can be extended by keeping the batteries fully charged at all times. Periodically charging the batteries with a battery charger may be able to charge the batteries more completely than the vehicle's alternator in certain severe applications. Use a battery charger (float charger) that automatically reduces amperage or shuts off when the batteries are fully charged. Use of a Midtronics 55-Amp Power Supply/Smart (Battery) Charger, Model Number PCX550, Part Number PSC550CCKIT (or equivalent), available through your International dealer, is recommended.

Cold batteries resist charging. Battery performance can be improved by regularly or even periodically storing vehicles and charging batteries with an automatic float charger for 8 to 24 hours in a warm garage during the cold winter months.

### CAUTION

**Allowing batteries to become heavily discharged and exposed to subfreezing weather will cause them to freeze and become damaged.**

Your vehicle utilizes maintenance-free batteries, which will not require the periodic addition of water. Wipe the tops of the batteries clean to avoid a slow current flow through the dirt, resulting in a loss of charge. Be sure the terminals are clamped tightly and that the battery is clamped securely in the battery box.

For best results:

- Do not mix and match battery models/manufacturers in the same battery pack.
- Do not use batteries with differing CCA ratings in the same battery pack.
- Do not use batteries with more than one year difference in the installed age of batteries in the same battery pack.

### Battery Cables

### CAUTION

**When working around the terminals and battery, use extra care to prevent shorting. A good practice is to insulate pliers and screwdrivers. Do not check battery condition by shorting (flashing) across terminals.**

Battery cable terminals must be clean and tight. Use a mixture of hot water and common baking soda for removing terminal

corrosion and for cleaning the top of the battery. Brighten the contact surfaces with steel wool, apply a light coat of lubricant sealing grease, such as Fleetrite® 472141-C1 or equivalent or a spray protectant, and reassemble. Be sure the terminals are clamped tightly.

### Electrical Charging and Starting System Test

At every PM, fully charge the batteries using an automatic float charger. Then, have a qualified technician perform an electrical system test using an International® Electronic System Tester (Midtronics inTELLECT EXP HD Expandable Electrical Diagnostics Platform available through your local International dealer) to catch electrical system problems before they cause further damage to the batteries and prevent a stranded vehicle. The test will check for alternator amperage output, starter current draw, and battery amperage capacity. This type of testing will detect weaknesses that may not yet be apparent during normal daily operations.

### Terminal Inspection-Cleaning-Corrosion Protection

Periodically inspect electrical connectors on the engine, battery, and frame for corrosion and tightness. Inspect exposed cables for fraying or signs of abrasion. Exposed terminals, such as cranking motor, alternator, and feed-through studs should be cleaned and recoated with a dielectric grease, such as Fleetrite® 472141-C1 or equivalent paste or spray protectant. The inspection/cleaning/corrosion protection should include feed-through connections, power and ground cable connections for batteries, engines, and the starter stud.

## Maintenance Instructions

---

Connectors that are more subject to corrosion may be disassembled and sprayed internally with a light coating of dielectric grease. Use grease sparingly, as too much grease will not allow air to escape from the connection and this compressed air will push out the seals in the electrical connectors.

### Accessory Feed Connections



**Electrical circuits are designed with a particular wire gauge to meet the fuse and circuit breaker current rating. Do not increase size of fuse or circuit breaker or change type of breaker supplied with your truck. To do so could cause wiring to overheat and possibly burn, resulting in a fire which could cause property damage, personal injury, or death.**

Vehicle electrical systems are complex and often include electronic components, such as engine and transmission controls, instrument panels, antilock brakes, etc. While most systems still operate on battery voltage (12 volts), some systems can be as high as 90 volts or as low as 5 volts. Refer to the Electrical Circuit Diagram manuals, available from your International dealer, to ensure that any body lights and accessories are connected to circuits that are both appropriate and not overloaded. No modification should be made to any vehicle control system without first contacting your International dealer.

### Fuses and Relays

Fuses and relays are located inside the cab within the fuse panel cover. Refer to the schematic located on the fuse panel cover in the cab, the schematic on the fuse cover in the luggage compartment, or the **Fuse Panel Schematic** located in **SECTION 8 — MAINTENANCE INTERVALS AND SPECIFICATIONS** of this manual for fuse or relay replacement.

### Engine

#### General Information

**NOTE:** For complete operation and maintenance information pertaining to your engine, refer to the Engine Operation and Maintenance Manual provided with the vehicle.

For effective emission control and low operating cost, it is important that maintenance operations be performed at the specified periods or mileage intervals indicated in the Engine Operation and Maintenance Manual.

Service intervals are based on average operating conditions. In certain environments and locations, more frequent servicing will be required.

The required maintenance operations may be performed at a service establishment. Any replacement parts used for required maintenance services or repairs should be genuine OEM service parts. Use of inferior replacement parts hinders operation of engine and emission controls and can reduce engine life and/or jeopardize the warranty.

Receipts covering the performance of regular maintenance should be retained in the event questions arise concerning maintenance. The receipts should be transferred to each subsequent owner of the engine (vehicle).

### Engine fluids and contaminated material



**GOVERNMENT REGULATION:** Engine fluids (oil, fuel, and coolant) may be a hazard to human health and the environment. Handle all fluids and other contaminated materials (e.g., filters, rags) in accordance with applicable regulations. Recycle or dispose of engine fluids, filters, and other contaminated materials according to applicable regulations.

### Scheduled Maintenance

For information regarding routine scheduled maintenance such as replacement of oil, filters, coolant, belts, belt tensioners, etc., and inspection and adjustment of items such as valve lash, etc., refer to the Engine Operation and Maintenance Manual supplied with the vehicle.

### Air Induction System



**To prevent personal injury or death when performing maintenance and repairs to any turbocharged engine with engine air inlet piping disconnected, a turbocharger compressor air inlet protective shield should be installed over the turbocharger air inlet.**

Once each year perform a complete inspection of the air induction system. In areas where road salt is used, the inspection consists of disassembling the joints of each metal component and inspecting for salt build-up that can cause particles to flake off and enter the engine combustion chambers.

If evidence of corrosion is found (usually appears at the pipe connections), use a wire brush to clean the inside of the pipes and inside of the rubber hoses.

If the intake pipes are pitted at the joint ends, use RTV Silicone to seal the joints. Be certain that no excess material that can be pulled into the engine is on the inside of the pipe. If the service condition of the pipes, hoses or clamps is questionable, replace those parts.

- Check for loose hoses and clamps.
- Check for ruptured, bulging, or collapsed hoses.
- Check air cleaner housing for cracks.

## Maintenance Instructions

---

### Air Restriction Gauge

The air restriction gauge indicates how much engine air cleaner filter capacity has been used and how much filter capacity remains. It measures maximum restriction of the filter element when the engine is operated at full load and locks at that point. This feature gives the operator the capability of reading maximum restriction with the engine shutdown.

The gauge is mounted on the forward side of the air cleaner housing, or optionally on the center dash panel/wing panel.

It is recommended that the operator not reset the gauge until it has been determined if air cleaner service is required.

The initial restriction with a new air filter element will vary with air cleaner design and installation.

After servicing the filter element, reset the yellow indicator by pushing the reset button and releasing it. The yellow indicator will drop to near or below the window so the air restriction gauge can be reused.

**NOTE:** After starting engine, indicator may be seen in lower part of window. This is normal and should not be mistaken as a signal for element service.

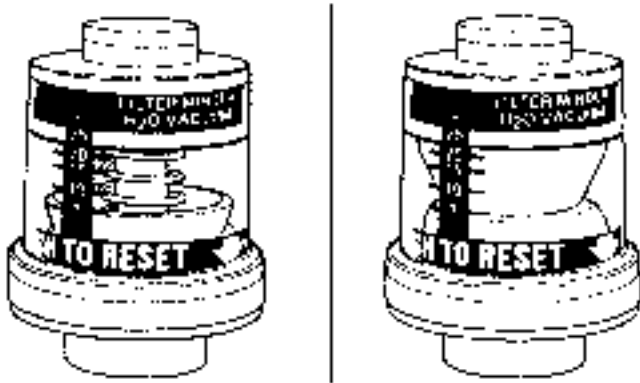

448/1100



### Air Cleaner Element Service

This vehicle comes with a selection of two air cleaner options. The first option is a single element. The second option is a dual element air cleaner that is available for applications in excessively dusty environments that may require more frequent service intervals. The secondary element is inside the primary element and prevents contaminants from entering the engine air intake system during service of the primary element, or in cases where the primary element becomes damaged. Both options are serviced in a similar manner.

**NOTE:** Do not change the air cleaner element configuration from the factory installed configuration. If equipped with a single element or dual element that configuration must stay with the vehicle. Failure to comply may affect engine performance.

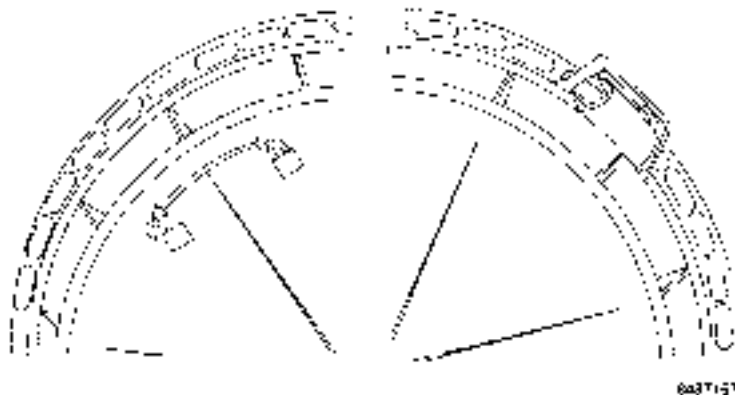

**NOTE:** Be careful not to bump the air filter element while it is in the housing; this can raise a cloud of dust that can enter the clean side of the piping to the turbocharger.

1. Lift and hold the locking tab (located at the 2 o'clock position). Rotate the cover counterclockwise (in direction of unlock symbol on cover) to release cover tabs and pull to remove the cover. Remove the filter element(s) carefully and slowly, then discard the old element(s).
2. Wipe the inside of the air cleaner housing with a clean, damp cloth. Be sure to clean the gasket sealing surface. Be sure to wipe out any dust that has fallen into the port to the turbocharger. DO NOT use compressed air for this cleaning!
3. Visually inspect the air cleaner housing for damage or distortion, which could allow unfiltered air to enter the engine. Inspect to be sure that the rubber dust unloader valve at bottom of housing is in place, free of debris, and not cracked.
4. Inspect the new air filter element for a damaged or nonresilient rubber gasket. Inspect the air filter element body for dents or excessive pleat bunching. If any of the mentioned conditions exist, obtain and install an alternate new air filter element from your International dealer.
5. Carefully install the new air filter element into the air cleaner housing.

## Maintenance Instructions

---

6. With the air cleaner cover latch at the 1 o'clock position, align cover tabs with corresponding slots. Push the cover into the slots. Rotate the cover clockwise (in direction of lock on cover) until the locking tab snaps into its locked position.
7. When servicing is completed, reset air restriction gauge by pushing and holding the reset button and releasing it. The yellow indicator will drop below the window. The air restriction gauge is now ready for the next operating cycle.



**NOTE:** After starting engine, the indicator may be seen in the lower part of the window. This is normal and should not be mistaken as a signal for element service.

Troubleshooting

No Restriction Reading

| POSSIBLE CAUSES  | HOW TO CHECK   |
|--|--|
| Plugged fitting or vacuum line                           | Remove the gauge and apply a vacuum until it is locked up at the red zone. Re-insert the gauge and hold in the reset button. Indicator will fully return unless line or fitting is plugged. A slow return is normal due to safety filter in fitting. |
| Leak in vacuum line                                      | Apply vacuum to gauge until locked up at red zone. Re-connect gauge and close end of line airtight. Hold in reset button. Indicator will drop slightly and then not move unless vacuum line has a leak.  |
| Leak in gauge  | Repeat above except close gauge connection airtight.   |
| Engine airflow too low to generate a restriction reading | Turbocharged engines must be full load to pull full engine airflow.  |
| Air cleaner element split open                           | Visually inspect element.  |

High Restriction Reading

| POSSIBLE CAUSES                     | EXPLANATION  |
|-------------------------------------|--|
| Plugged outer element               | Particles in outer filter media restrict airflow. Replace outer element.   |
| Plugged inner element (if equipped) | Replace inner element.   |
| Plugged inlet screens or ducts      | Check system upstream from restriction tap for debris, damage or improper installation.  |
| Heavy snow or rain                  | Temporary high restriction can occur during a rain or snow storm; it disappears after drying out. If gauge is locked up at red zone, check elements for damage. Reset gauge. Reuse element, recheck gauge reading. |

## Maintenance Instructions

---

### Charge Air Cooler And Radiator Core Inspection And Cleaning

#### *Inspection and Cleaning*

With the engine off, visually inspect the charge air cooler core and radiator core assembly for debris and clogging of external fins. Prior to engine operation, remove any debris blocking the core.

The cores may be cleaned by externally backflushing them with compressed air and/or water. Use high pressure air or water Thexton radiator cleaning wand with 90-degree tip P/N 4106-NAV available from you International dealer for best results.

### Cooling System

#### *Coolant Level Check*



**To prevent personal injury or death from hot coolant or steam, use only the following procedure to remove the pressure cap from the radiator or expansion tank. Allow the engine to cool first. Wrap a thick, heavy cloth around the cap. Unscrew the cap slowly to allow pressure to release from under the cap. After the pressure has been released, the pressure cap may be removed.**



**Do not exceed the pressure rating on the de-aeration tank cap. Ensure that the pressure rating of the de-aeration tank cap matches that listed on the side of the tank, or the tank may burst, causing property damage, personal injury, or death.**



**If the coolant should get extremely low and the engine very hot, let the engine cool for approximately 15 minutes before adding coolant; then, with the engine running, add coolant slowly. Adding cold coolant to a hot engine may crack the cylinder head or crankcase. Never use water alone.**

#### *Filling Instructions*

**NOTE:** If system has been drained, fill with fresh 50/50 diluted concentrate coolant or 50/50 pre-mixed coolant. If the system has been flushed with water, a significant amount of the freshwater flush will remain in the system. In this case refilling with a mixture with a higher percentage (75%) of coolant concentrate is advised in order to achieve a final mixture close to 50/50.

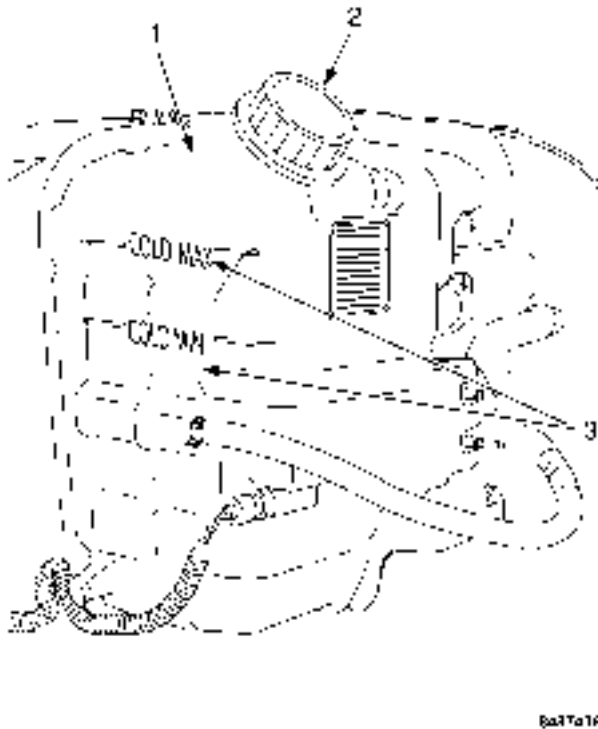

1. Deaeration Tank
2. Vented Fill Cap
3. COLD MIN and COLD MAX Lines

**NOTE:** Vented fill cap may differ slightly in location on tank between engine sizes.

To function properly, the coolant system must be completely filled with coolant and all air must be expelled. To accomplish this, the following procedures should be carefully completed:

1. Turn on ignition without starting the vehicle. This opens the electrically actuated LTR coolant flow valve.
2. Fully open cab heater coolant shut-off valves and coolant system vent valve.
3. Remove fill cap and pour a 50/50 mixture (75/25 if it has been flushed with water) of the proper (Nitrite-Free Shell Rotella® Ultra Extended Life Coolant) coolant concentrate and demineralized or distilled water into the de-aeration tank. A 50/50 coolant mixture will achieve a  $-34^{\circ}\text{F}$  ( $-37^{\circ}\text{C}$ ) freeze point. A 53/47 coolant mixture will achieve a  $-40^{\circ}\text{F}$  ( $-40^{\circ}\text{C}$ ) freeze point. The first pour should reach to the top of the reservoir fill neck.
4. Because the radiator fills slowly, it is important to continue to top off the system for two minutes following the initial fill.
5. Close coolant system vent valve, start the engine, and continue to add enough coolant to keep the coolant level between the COLD MIN and COLD MAX levels marked on the deaeration tank. Replace the deaeration tank cap tightly after adding make-up coolant for two minutes.
6. Run engine at governed speed until engine fan has fully engaged for 5 minutes. Do not exceed  $220^{\circ}\text{F}$  ( $104^{\circ}\text{C}$ ).
7. Let engine completely cool. Re-check coolant level and concentration/freeze point with a refractometer and top off as needed to achieve a coolant level at the COLD MAX line when cold.

## Maintenance Instructions

---

### *Coolant and Optional Coolant Filter*

The cooling system in vehicles with MaxxFer® 11, 13 and 15 engines, is filled at the factory with Nitrite-free Shell Rotella® Ultra ELC (Yellow) coolant. International Truck recommends using only the approved coolant with the 2010 cooling packages, and will not warrant these cooling systems that have not utilized the recommended coolant.

The label on the deaeration tank provides additional coolant/antifreeze information. Consult the Engine Operation and Maintenance Manual for coolant service life details.

Some engines are ordered with an optional coolant filter that should be replaced periodically.

For Ultra ELC equipped vehicles use only water filters **without** Supplemental Coolant Additives (SCA's) as SCA's are not necessary with Ultra ELC. Any time a silicone gasket/seal exposed to the coolant is replaced while using Ultra ELC, a fresh charge of silicates must be added to the coolant to protect the new gasket/seal.

International® truck recommends Ultra ELC due to its ease of maintenance and lower long-term cost of operation. Any system using or contaminated with more than 10% conventional coolant must be maintained like conventional coolant and receive regular tests for Supplemental Coolant Additive (SCA) levels.

### *Coolant Concentration Freeze Point*

Cooling systems should be checked twice a year to assure proper coolant water concentrations. A 53/47 coolant/water mixture from the factory provides freeze protection down to

minus -40° F (-40° C) as well as excellent corrosion protection. A 50/50 mixture can be easily created in the shop using undiluted coolant and water and will provide freeze protection down to -34° F (-36.7° C) if no further dilution is experienced during installation.

Concentrations greater than 67% are not recommended. The use of Shell Rotella® Ultra ELC pre-mixed to make up for coolant loss will assure the glycol/water concentrations stay in balance.

### **CAUTION**

**Always use Shell Rotella® Ultra ELC to top-off ELC-equipped cooling systems. Failure to do so may result in the loss of extended life properties and will require periodic testing for SCA levels. Should top-off occur with conventional coolant(s) exceeding 10% of the total cooling system capacity, either drain and refill with Shell Rotella® Ultra ELC or maintain as a conventional coolant system using SCA's at the recommended levels.**

### *Antifreeze*

For cooling system capacities, coolant part numbers, and other information refer to **SECTION 8 — MAINTENANCE INTERVALS AND SPECIFICATIONS** of this manual.

### *Fan Clutch*

Inspect for proper operation, secure electrical connections, and air supply as appropriate. See the Service Manual for details.

Start cold engine and view fan to see that it is rotating slower than the fan pulley (fan clutch is disengaged). Achieve operating temperature and observe that the fan is engaged.

### Fuel System



**GOVERNMENT REGULATION: Diesel fuel sold for use in 2007 and later highway vehicles must be limited to a sulfur content of 15 parts per million (ppm).**

Frequently inspect condition of fuel tanks and mounting hardware, fuel tank cap and vent, fuel lines, clips and routing. At every PM (or daily if necessary) drain water and sediment from the fuel/water separator filter (if equipped). If the vehicle is equipped with an optional Davco® fuel/water separator, inspect the level of the fuel in the see-through globe and replace the fuel/water separator filter element if the fuel level has reached the top of the globe. In all cases, be sure to use the proper fuel/water separator filter element with the correct part number and filter efficiency rating.

#### *Fuel Tank Draining and Cleaning*

Periodically (annually is recommended) drain water and sediment from the fuel tank via the drain plug on the bottom of the fuel tank. Drain and flush sediment from fuel tank at least every 12 months or more frequently if fuel quality or type of fuel dictates.

Since Ultra-Low Sulfur Diesel (ULSD) fuel tends to absorb more water and engines are operating at higher temperatures, microbe growth in the fuel tanks has become more prevalent. Microbe growth results in more contaminants in the fuel and reduces fuel filter life. Since fuel tank draining does not remove all microbes, fuel tank draining alone will not eliminate the problem. For vehicle operators experiencing microbe growth in their fuel, the following is recommended:

1. Drain and clean the fuel tank(s) every 12 months or more often. Clean the tanks with a professional fuel tank cleaning system (available through your dealer) or have your local dealer perform the service for you.
2. Treat your vehicle fuel tanks and bulk tanks regularly with a biocide from a reputable vendor.
3. Purchase fuel only from vendors that pretreat their fuel with biocides.
4. Periodically test the fuel supplied by your fuel vendor for the presence of microbes.

### Crankcase Ventilation Filter

Refer to the Engine Operation and Maintenance Manual for the proper replacement interval and instructions.

### Frame

International® chassis are manufactured with frame rails of HSLA steel and each must be handled in a specific manner to assure maximum service life. Before attempting frame repair or modification, consult the Service Manual or your International® Truck Dealer.

## Maintenance Instructions

---

### Noise Emissions – Exterior

#### Instructions for Proper Maintenance

In order to comply with federal exterior noise regulations, your vehicle may be equipped with noise emission items. Depending upon the vehicle configuration, it may incorporate all or some of the following:

#### Air Intake System

- **Air Cleaner** – should be inspected and its location should not be altered. Do not alter inlet and outlet piping.

#### Body

- **Wheel Well** – splash shields, cab shields, and underhood insulation should be inspected for deterioration, dislocation, and orientation and repaired or replaced as necessary.

#### Cooling System

- Check fan for damage to blades. Replace, if damaged, with manufacturer's recommended parts. Inspect for fan-to-shroud interference and any damage to shroud, such as cracks and holes.
- Fan speed ratio should not be changed and fan spacer dimensions and position should not be altered.
- Inspect for proper operation of fan clutch, making sure that the fan is disengaged when cooling of engine is not required.

#### Engine Noise Shields/Blankets

- Engine valve covers, oil pans, and block covers are made to damp out engine mechanical noise and, if needed, should be replaced with original equipment parts.

#### Exhaust System

- Inspect for leaks at various joint connections and tighten clamps. Make visual inspection for cracks or holes in muffler and tailpipe. Always replace with manufacturer's recommended parts. Tailpipe elbow or offset tailpipe orientation must not be changed from standard position as originally received.
- To avoid abnormal changes in vehicle sound level, it is necessary for the owner to perform inspections and necessary maintenance at the intervals shown in the maintenance schedules, and record them on the inspection verification form provided.

#### Diesel Particulate Filter (DPF)

##### Regeneration

Collected soot particles in the Diesel Particulate Filter (DPF) are automatically burned off through normal regeneration (initiated by normal exhaust heat during the normal operation of the vehicle). If conditions for normal regeneration cannot be achieved, it may be necessary to perform a parked regeneration as indicated by the instrument panel gauge cluster warning indicators. See the Parked Regeneration Procedure in **SECTION 6 — OPERATION**.



### Cleaning

If on-vehicle regeneration is unsuccessful at removing soot from the DPF, the DPF may need to be removed from the vehicle and be cleaned with the appropriate machinery and processes.

Ash residue in the DPF comes primarily from fuel and oil additives and will not burn or pass through the DPF. Ash residue accumulates very slowly in the DPF, but must eventually be removed to prevent excessive exhaust backpressure. If the DPF needs to have nonregenerable soot or the ash residue removed, please take the vehicle to an International dealer.

### Drive Shafts

At the regular lubrication interval, check universal joints, slip joints, slip joint boot, and carrier bearings for any evidence of wear or looseness. Should drive shaft vibrations occur, stop the vehicle immediately to avoid possible hazardous consequences or damage to other components.

### Suspension (Air and Steel Springs)

#### CAUTION

**Do not adjust air suspension height to any setting other than the specified setting. Altering the height setting will change the driveline angle and may result in unwarrantable component damage, such as transmission component damage.**

Verify drive axle air suspension height at engine oil change intervals. See the appropriate Service Manual.

**NOTE:** Suspension alignment must be maintained at all times.

**NOTE:** Refer to **SECTION 8 — MAINTENANCE INTERVALS AND SPECIFICATIONS** for proper U-bolt torque values.

Periodically:

- Check condition of spring leaves for evidence of fatigue, bending or breakage.
- Check condition of suspension mounting brackets and bushings.
- Check that suspension mounts (brackets, bushings, fasteners, etc.) are tight.
- Check that torque rod mounting fasteners are tight.
- Check U-bolts as follows:
  1. After the chassis has been operating under load for 1,000 miles (1,600 km) or six months, whichever comes first, the U-bolt nuts must be re-torqued.
  2. Thereafter, the U-bolt nuts must be re-torqued every 36,000 miles (58,000 km). Re-torque interval may be lowered to 25,000 miles (46,000 km) to synchronize with oil change interval.

### Front Suspension

The front suspension should be regularly inspected for loose, worn, or broken components. Front suspensions/axles should be checked periodically for proper alignment to promote maximum tire life.

## Maintenance Instructions

---

On vehicles equipped with the optional front air suspension, the air suspension components, including air bags, height control valves, air lines, and fittings should be inspected for wear, damage, and audible air leaks

### Rear Suspension

The rear suspension should be regularly inspected for loose, worn, or broken components. Rear suspensions/axles should be checked periodically for proper alignment to promote maximum tire life. The optional International® Truck Ride Optimized Suspension (IROS) components, including air bags, height control valves, air lines, and fittings should be inspected for wear, damage, and audible air leaks.

### Steering

#### General Information



**Always follow recommended procedures for steering system maintenance. Failure to maintain the steering system in proper condition can cause reduced steering ability resulting in property damage, personal injury, or death.**

Have a technician examine the steering mechanism. Minor adjustments could head off further problems.

Check tie rod ends, drag link ends and king pins. Joints and fasteners must be tight. Articulating joints must be well lubricated.

Check for installation and spread of cotter pins and tightness of nuts at both ends of tie rod and drag link.

Check that pitman arm (steering arm at steering gear) mounting is tight and locked. Check system for leaks or hose chafing.

Maintain proper power steering fluid levels.

Regularly inspect steering column joint bolts and steering linkage, particularly for body-to-chassis clearance.

**NOTE:** Have any steering problems corrected at once by a qualified service technician.

#### Tightening Steering Intermediate Shaft Joint Bolts

As a good maintenance practice, it is recommended that steering intermediate shaft joint bolts be checked for tightness every 120,000 miles (193,000 km) or annually, whichever occurs first.

## Lubrication Points

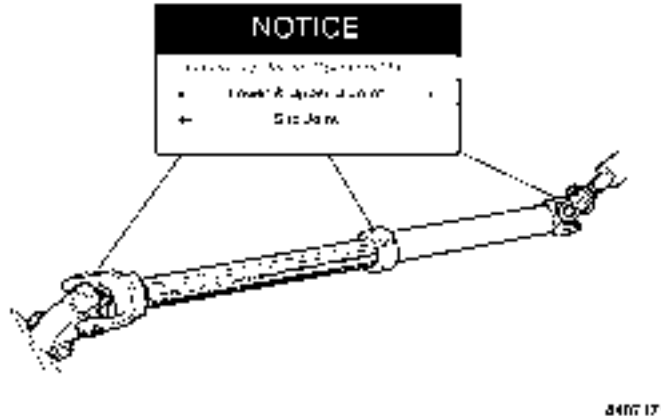

The steering shaft is lubricated at the three points shown in the illustration above. For the correct maintenance interval, refer to **SECTION 8 — MAINTENANCE INTERVALS AND SPECIFICATIONS**.

## Power Steering

Whenever the power steering system has been drained and refilled for any reason, air must be bled from the system before returning the vehicle to service. Failure to properly bleed the hydraulic system can result in degradation of power system performance.

Consult your International® Truck dealer who is aware of the proper procedures for filling and bleeding the system.

The power steering fluid filter is located inside the power steering reservoir. To remove the filter, unscrew the large cap on the power steering reservoir and unscrew the filter. Reverse the procedure to install the new filter.

With time, the large square-cut reservoir cap O-ring seal may shrink slightly. To assist in reinstallation of the cap, the O-ring may need to be stretched. To stretch the O-ring, pull on it while pinching it between your thumb and finger. It must be large enough to stay completely in the shallow groove in the top edge of the reservoir prior to cap installation. Replace cracked or damaged O-rings.

Refer to **SECTION 8 — MAINTENANCE INTERVALS AND SPECIFICATIONS** for the fluid and filter replacement intervals.

## Tires

### Tire Warnings



**Due to tire manufacturers re-marking tires to conform to the SI (metric) system, tires marked with old and new loads or inflation pressures could be placed on the same vehicle. For field maintenance, only inflate and load tires to the maximum of the least-rated tire on the axle. Failure to adhere to this warning could possibly result in tire malfunction, damage to your vehicle, personal injury, or death.**



Always maintain your tires in good condition. Frequently check and maintain correct inflation pressures as specified by tire manufacturers. Inspect periodically for abnormal wear patterns and repair/replace cut or broken tire casing. Always use experienced, trained personnel with proper equipment and correct procedures to mount or remove tires and wheels. Failure to adhere to these warnings could result in wheel or tire malfunction, damage to your vehicle, personal injury, or death.



To prevent personal injury or death, always follow these instructions when mounting tires on wheels:

- Only personnel who have had proper training and experience should mount or remove tires from rims or wheels.
- Use only heavy-duty rims or approved rims for radial tires. It may be necessary to contact your wheel and rim distributor to determine if your rims are approved for radial tires.
- If a tube is to be used, make sure special radial tire tubes are used because of the increased flexing of the sidewalls on radial tires.
- Never use antifreeze, silicones, or petroleum-based lubricants when mounting radial tires. Only an approved lubricant should be used as an aid for mounting tires.
- Always inflate tires in a safety cage.



- **Do not mix stud-piloted wheels or fasteners with hub-piloted wheels or fasteners. Premature wheel failure can result in property damage, personal injury, or death.**
- **Do not change from steel wheels or a steel inner and aluminum outer wheel combination to aluminum wheels without changing the mounting hardware since the thicker aluminum wheels require longer studs. In some cases with flange nut mounting systems, changing the hub and stud assembly may be required. Improperly mixing components could cause wheel or fastener failures and result in property damage, personal injury, or death.**



**Do not mount tube-type tires on tubeless wheels or tubeless tires on tube-type wheels. To do so could result in tire or wheel failure and cause property damage, personal injury, or death.**

### Tire Maintenance

Preserving proper inflation pressure is a very important maintenance practice to ensure safe vehicle operation and long life for the tires.

Failure to maintain correct inflation pressure may result in sudden tire destruction, improper vehicle handling, and may cause rapid and irregular tire wear. Therefore, inflation

pressures should be checked daily and always before long-distance trips.

Follow the tire manufacturer's recommended cold inflation pressure for the tire size, type, load range (ply rating), and axle loading typical for your operation. (Each steer axle tire load will equal 1/2 steer axle loading; each drive tire load will be 1/4 the axle loading, if fitted with four tires.)

#### *Checking Inflation*

Always check inflation pressure when tires are cold. Never bleed air from hot tires to relieve normal pressure buildup. Normal increases in pressure during operation will be 10 to 15 psi (69 to 103 kPa), which is allowable in truck tires. Tires on the same axle should have the same air pressure as the corresponding other tire(s) on that axle. Steer tires should be within a 3 psi (21 kPa) pressure range. All drive tires should be within a 5 psi (34 kPa) pressure range. Tag or pusher axle tires on the same axle should be within a 5 psi (34 kPa) pressure range.

To minimize rim corrosion, it is particularly important to keep moisture from the inside of tires and proper selection of air compressor equipment, proper air line routing, and the use of shop air dryers is strongly recommended to avoid moisture in the high-pressure air used for tire inflation.

#### *Underinflation*

Tires should not be allowed to become underinflated. Increased flexing due to underinflation causes heat buildup within the tire components. This leads to reduced strength, breakdown of the rubber compounds and possible separation of the

## Maintenance Instructions

---

tire components (i.e., ply and tread separation and reduced retreadability).

Underinflation is also the primary cause of blowouts. In addition, low inflation causes an increase in rolling resistance. This results in reduced fuel mileage, a loss in tread life, and uneven wear due to increased tread movement. To determine proper inflation, refer to the tire inflation range stated on the tire sidewall and the tire manufacturer's tire load-pressure charts.

### SmartWave® Tire Pressure Monitoring System (TPMS)

#### CAUTION

**SmartWave® tire sensors can be broken when mounting and dismounting a tire unless specific instructions are followed. If tire work is done by a non SmartWave® authorized facility, please let them know that a tire pressure monitoring system is installed on the vehicle before they remove a tire from a wheel. Refer to <http://www.smartire.com/support/manuals> for complete owner's manual.**

The optional SmartWave® Tire Pressure Monitoring System (TPMS) warns the driver that tire pressure is below set pressure. Air pressure sensors are installed on the inner rim of each wheel. The standard user interface is a round display located in the center dash panel. If the vehicle is equipped with the optional Electronic Vehicle Monitoring Driver Information Display (DID),

the DID will act as the user interface and the round SmartWave® display is not provided. Refer to the Driver Information Display operator reference card, supplied in the vehicle, for product information.

### Inspection

Check condition of tires for abnormal wear patterns and proper inflation pressures. Cut or broken tire casings must be repaired or replaced.

Tires should be inspected for the following conditions. If any are present, the tire should be removed and repaired, retreaded, or scrapped as the condition indicates.

- Any blister, bump, or raised portion anywhere on the surface of the tire tread or sidewall (other than a bump made by a repair). These indicate the start of internal separation.
- Any cut that reaches to the belt or ply cords or any cut that is large enough to grow in size and depth.
- Any nail or puncturing object.
- If any stone or object is held by a tread groove and is starting to drill into the tread base, remove the object.

Proper tire inflation, toe-in adjustment, loads, and road speeds are important factors governing tire life, steering ease, maneuverability, fuel economy, and ride quality.

### Loads



**Loading tires beyond their rated capacity decreases tire life requiring more frequent replacement of tires. Overloading creates an unsafe condition that may result in sudden air loss from a tire failure resulting in an accident that could cause property damage, personal injury, or death.**

**NOTE:** The load rating of the tires installed on your vehicle at the time of your vehicle's production is at or in excess of the Gross Axle Weight Rating (GAWR) generally found on a label on the B-pillar of your vehicle. When replacing tires, be sure that the replacement tire load rating (listed separately in pounds and kilograms on the tire sidewall for single or dual applications) multiplied by the number of tires on that axle is equal to or higher than the specific listed Steer Axle or Drive Axle GAWR. Failure to do so will adversely affect maximum load-carrying capacity. Tires with the same size specification do not always have the same load specification.

### Dual Tires Matching

Dual tires should be matched using tires of equivalent size. Tires which differ more than 1/4 inch (6 mm) in diameter or 3/4 inch (19 mm) in circumference should not be mounted on the same dual wheel assembly.

### Dual Tires Mixing

**NOTE:** Never mix bias and radial tires on this vehicle.

It is recommended for best overall performance that only radial tires be used on this vehicle.

Never mix different tire sizes or constructions on the same axle.

### Rotation

- Steer tires that have developed some type of irregular wear pattern can be rotated to drive axles if rib tires are being used on all wheel positions. Applying steer tires to a drive position will often wear off the irregularities and they can be moved back to the steer axles or run out to retread stage on the rear axle.
- Another rotation possibility for fleets with rib tires in all wheel positions is to break in the new steer tires in the drive axle positions, then move them to steer axles. This will wear away tread rubber relatively quick in the early life of a tire when it is most likely to develop an unusual wear pattern.
- Drive axle tires may be placed on the other end of the same axle so that direction of rotation is reversed. This is often helpful if a heel and toe or alternate wheel nut wear pattern has developed.

### *Rotation Is Advisable*

1. If front (steering) axle tires become irregularly worn, move to rear position.

## Maintenance Instructions

---

2. In a dual assembly, reverse the position of the tires if one tire wears much faster than its mate.
3. On the drive axle, if heel and toe wear or alternate wheel nut wear occurs, rotating the tires from one end of the axle to the other end of the axle may help even out this wear.

### *Tire Replacement*

**NOTE:** Retread tires are not recommended for use on steering axles of trucks.

- **Front (Steering) Axle** - Tires must be removed when tread is worn to 4/32 inch (3 mm) or less. Retread or rotate worn tires to drive position.
- **Rear Axles** - Tires must be removed when tread is worn to 2/32 inch (2 mm).

**If rib tire is used on front axle and lug- or off-road-type on rear axle positions:**

- **Front (Steering) Axle** - Replace tires at front wheels when tread is worn to 4/32 inch (3 mm) or less.
- **Rear Axles** - Tires must be removed when the tread is worn to 2/32 inch (2 mm) or less. Tires identified with the word regroovable molded on the sidewall can be regrooved. A minimum of 3/32 (2.38 mm) of undertread must be left at the bottom of the grooves.

### **Wheel and Tire Balancing**

Out-of-round or out-of-balance wheels or tires can cause vehicle vibration and bounce, and shimmy. Replace damaged or out-of-round wheels. Out-of-round tires and wheel assemblies can be corrected by rechecking the tire relative to the wheel. The tire and wheel assembly should thereafter be dynamically balanced and reinspected while spinning for an out of round condition.

### **Wear**

Radial tires can exhibit three types of normal wear patterns, even, erosion, or chamfer.

**Even Wear** is a sign that the tire is being properly used and maintained.

**Erosion Wear** has also been called rolling wear, channel, or river wear. Erosion wear is found more often at free rolling tires. This is an indication that the tire is being used in a slow wearing operation. What happens is that the belt plies are held very rigid and the tread is not allowed to distort as it passes through the contact area. Wear will only occur at the edge of the tread. No corrective action required. If erosion gets to be 1/16 inch (2 mm) or more, the tire may be rotated to a drive axle.

**Chamfer or Shoulder Wear**, with tires inflated properly, is a normal tendency of most radial tire designs. If both inside and outside shoulders are wearing evenly around the tire, no further action is required. Overinflation is not effective in correcting this effect.



### *Irregular Wear*

If irregular wear is present, check the axle alignment, tire pressure, wheel balance, shock and suspension component condition, and wheel bearing end play.

This condition not only shortens tire life, but will adversely affect the handling of your vehicle.

Rotating tires from one wheel position to another is a way often used to even out many types of irregular wear or to avoid it altogether. See **Tires – Rotation** for more information. Some of the more effective tire rotation programs are:

#### **Irregular wear can be minimized by:**

- Using the right inflation pressure for the load being carried.
- Maintaining proper front wheel alignment - **especially toe-in** - to specifications.
- Maintaining proper tire and wheel balance.
- Maintaining shock absorbers and suspension components.
- Maintain proper wheel bearing adjustment .

#### **Use of Tire Chains**

Refer to chain manufacturer's recommendation for correct tire chain usage, installation, and removal.

## **Wheels**

### **Wheel and Wheel Nut Maintenance and Installation**



**To prevent personal injury or death, always follow these instructions when mounting tires on wheels:**

- **Only personnel that have had proper training and experience should mount or remove tires from rims or wheels.**
- **Use only heavy-duty rims or approved rims for radial tires. It may be necessary to contact your wheel and rim distributor to determine if your rims are approved for radial tires.**
- **If a tube is to be used, make sure special radial tire tubes are used because of the increased flexing of the sidewalls on radial tires.**
- **Never use antifreeze, silicones, or petroleum based lubricants when mounting radial tires. Only an approved lubricant should be used as an aid for mounting tires.**
- **Always inflate tires in a safety cage.**



- Do not mix stud piloted wheels or fasteners with hub piloted wheels or fasteners. Premature wheel failure can result in property damage, personal injury, or death.
- Do not mix foreign (not made in North America) wheel mounting parts with domestic (made in North America) parts. Many foreign wheel components look similar to, but are not exactly the same as domestic made components. Mixing components can cause wheel or fastener failures and result in property damage, personal injury, or death.
- Do not change from aluminum wheels to steel wheels, or vice-versa, without changing the mounting hardware. In some cases with flange nut mounting systems, changing the hub and stud assembly may be required. Mixing components could cause wheel or fastener failures and result in property damage, personal injury, or death.



When installing the tire and rim assembly on disc - brake equipped axles, make sure the tire valve stem clears the brake caliper. The use of either an International® truck valve stem retainer or a tire manufacturer's stem forming tool is the only acceptable method of obtaining clearance when necessary. Failure to obtain proper clearance may result in rapid tire deflation and cause property damage, personal injury, or death.

### *Wheel Nut Torque Maintenance*

Tighten and maintain wheel and rim mounting nuts to the proper torque. Loose nuts or overtightened nuts can lead to premature wear and possible failure of the wheel, rim, and/or mounting hardware.

### *Hub-Piloted Wheel Installation Procedures*



**Use only the same type and style wheels and mounting hardware to replace original parts. Failure to do so may result in an assembly, which looks fine, but does not fit together properly. This could cause wheel or fastener failures and result in property damage, personal injury, or death.**

Out-of-round tires and wheel assemblies can sometimes be corrected by relocking the tire relative to the wheel.

Tightening procedure for disc wheels with flange nuts (hub-piloted).

1. Clean the mating surfaces of the hub, drum, and wheel(s) as well as the wheel studs and wheel nuts with a wire brush prior to assembly.
2. Lubricate the two-piece wheel nuts by putting two drops of oil in the slot between the nut and washer and spin the washer to spread the oil around the nut-to-washer contact surface.
3. Carefully lubricate the wheel stud threads by wiping them with a freshly oiled cloth. Do not get the oil on any

other surfaces or the wheel clamping effectiveness will be reduced!

4. To prevent aluminum wheels from getting stuck on the hub due to corrosion, apply a thin coat of antiseize compound or disc brake corrosion control grease to the hub pilot pads only.
5. Slide the inner wheel (if duals) or steer wheel over the wheel studs and onto the pilot pads of the hub. Care must be taken to avoid damage to the stud threads while positioning the wheel. Ensure that the wheel is resting on the pilot pads and is against the brake drum.
6. Hand-start all wheel nuts to avoid cross-threading.
7. Starting with the nut at the 12:00 o'clock position and using the appropriate star or crisscross pattern (see wheel nuts torque sequence diagram), run the wheel nuts down the wheel studs with an impact wrench until they are snug against the wheel. The purpose of this step is to snug the wheel(s) in the correct position, not to apply the final torque. The tightening of each nut should be stopped immediately when the wheel is contacted, resulting in a wheel nut torque well below the final specified torque.
8. Use a calibrated torque wrench to apply the specified torque to each wheel nut in the sequence specified in the wheel nuts torque sequence diagram above. Refer to **SECTION 8 — MAINTENANCE INTERVALS AND SPECIFICATIONS** for proper torque values.

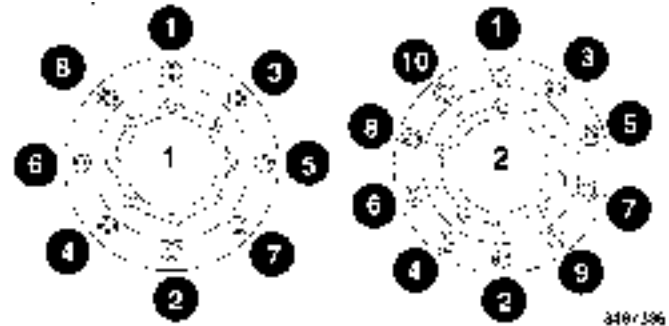

1. Flange Nut Mount – 8 Stud
  2. Flange Nut Mount – 10 Stud
9. All wheels undergo a process called joint settling when placed in service after a wheel installation has been performed. This process results in a reduction in the torque on the wheel nuts. To correct this condition, operate the vehicle normally for approximately 50 miles (80 km), then use a calibrated torque wrench to retorque the wheel nuts to specification using the appropriate pattern shown in the wheel nuts torque sequence diagram.
  10. As part of a daily pretrip inspection, look for loose or missing wheel nuts. Also look for rust streaks extending outward from the wheel nuts; this can be an indicator that one or more wheel nuts are loose, even if they cannot be turned by hand. Normal periodic maintenance should also include checking the wheel nut torque with a torque wrench.

## Maintenance Instructions

---

### Transmission

Check lubricant level. With the vehicle on level ground, verify that transmission lubricant level is even with the bottom of the inspection plug in the side of the transmission. Check shifter for proper operation.

- Check operation of transmission neutral safety switch. Try to start the vehicle in all shift selector positions other than neutral. The starter should **ONLY** operate when the shift selector is in Neutral.
- Refer to **SECTION 8 — MAINTENANCE INTERVALS AND SPECIFICATIONS** for information on transmission fluids and fluid change intervals.

## SECTION 8 — MAINTENANCE INTERVALS AND SPECIFICATIONS

### Lubrication and Maintenance Intervals

All new vehicles are factory-lubricated. Once the vehicle is in operation, regular lubrication and maintenance intervals (based on the type of service and road conditions) must be established and performed. Load weight, vehicle speed, road conditions, and weather conditions all contribute to lubrication frequency. Performing thorough lubrication and maintenance at the specified intervals will ensure an outstanding vehicle life and will reduce overall operating expense.

The LUBRICATION AND MAINTENANCE INTERVAL CHART contains an extensive list of components and systems. Listed items and systems must be regularly inspected, serviced, and/or replaced to maximize vehicle availability and minimize unexpected failures. Recommended synchronized intervals are shown for each item. This chart can serve as a convenient one-stop reference to research most maintenance needs.

Only lubricants of superior quality, such as Fleetrite® lubricants, should be used. The use of inferior products will reduce the service life of the vehicle or result in failure of its components. International Truck recommends the use of Fleetrite® lubricants for optimum performance.

### Maintenance Intervals

Maintenance intervals provided in this manual are for normal highway and environmental service conditions.

These intervals may be expressed in miles (kilometers), hours of operation, and/or months of operation. It is important to note that in high duty cycle types of operation and/or where operating conditions are extremely severe (such as in deep water, mud or unusually dusty conditions), the vehicle may require lubrication much more frequently than specified in this manual.

The synchronized “A” and “B” service intervals are designed to coordinate maintenance activities and to provide the appropriate levels for servicing components. Following the service intervals minimizes the number of times per year that the vehicle must be brought into the shop. In addition to the “A” and “B” service intervals, the “Special” Service Interval column is provided for items that need infrequent servicing. In most cases, these service intervals represent the recommended maximum intervals. For some components, however, the manufacturer’s recommended maintenance intervals may have been shortened to allow synchronization with other maintenance tasks.

The maintainer may wish to synchronize engine related items with other lubrication/maintenance intervals in order to reduce downtime, even though the recommended intervals in the Engine Operation and Maintenance Manual may be longer. **Engine Operation and Maintenance Manual maximum intervals (based on the actual operating conditions specified in that manual) must never be exceeded.**

## Maintenance Intervals and Specifications

---

### Lubrication and Maintenance Interval Chart Symbols Key

| Symbol  | Interval Definition                                 |
|---------|---|
| A       | EVERY 25,000 miles (40,000 km)/600 hours/3 Months   |
| B       | EVERY 50,000 miles (80,000 km)/1,200 hours/6 Months |
| SPECIAL | INTERVAL AS SPECIFIED.                              |

### Lubrication and Maintenance Interval Chart Notes

NOTE 1: A hand-pumped grease gun should be used for optimal grease distribution within the component joint.

NOTE 2: Kingpin thrust bearings must be lubricated through the lower kingpin grease zerk with the vehicle weight on the tires. Kingpin bushings must be lubricated through the upper and lower kingpin grease zerks with the vehicle weight off of the tires.

NOTE 3: Certain services are performed at Special Intervals or in addition to A or B Service when the interval dictates.

**Lubrication and Maintenance Interval – Recommended Synchronized Intervals**

| <b>System</b>        | <b>Item</b>   | <b>Intervals</b>           | <b>Special Interval (3) : miles (km) / hours / months</b>                       |
|----------------------|---|----------------------------|---|
| Pre-Trip Inspection  | Pre-trip Inspection Items listed in SECTION 3 – INSPECTION GUIDE      | DAILY                      |   |
| Front Axle           | Wheel Bearing-Oil Type – Check Level                                  | A, B                       |   |
|                      | Suspension Fasteners / Components – Check                             | A, B                       |   |
|                      | Tie Rod Ends – Lubricate (NOTE 1)                                     | A, B                       |   |
|                      | Drag Link Ends – Lubricate (NOTE 1)                                   | A, B                       |   |
|                      | King Pins and Bushings – Lubricate (NOTE 1 and NOTE 2)                | A, B                       |   |
|                      | Shock Absorbers – Inspect   | A, B                       |   |
|                      | Wheel Bearings – Check End-play                                       | B                          |   |
|                      | Air Suspension (if equipped) – Check Ride Height (See Service Manual) | B                          |   |
|                      | Axle U-bolts – Retorque (NOTE 3)                                      |                            | At first 1,000 miles (1,600 km), then every 36,000 miles (58,000 km) thereafter |
|                      | Wheel Bearing Oil (including synthetic) – Change                      |                            | 100,000 miles (160,000 km)/–/12 months  |
| Axle Shocks (NOTE 3) |   | 300,000 miles (480,000 km) |   |

## Maintenance Intervals and Specifications

### Lubrication and Maintenance Interval – Recommended Synchronized Intervals (cont.)

| System  | Item  | Intervals                            | Special Interval (3) : miles (km) / hours / months  |
|---|---|--------------------------------------|---|
| Rear Axle   | Suspension Fasteners / Components – Check   | A, B                                 |   |
|   | Rear Axle Lubricant – Level Checks  | A, B                                 |   |
|   | Axle Flange Nuts – Retorque   | B                                    |   |
|   | Air Suspension (if equipped) – Check Ride Height (See Service Manual)                                   | B                                    |   |
|   | Axle U-bolts – Retorque (NOTE 3)  |                                      | At first 1,000 miles (1,600 km) then every 36,000 miles (58,000 km) thereafter.   |
|   | Rear Axle with Petroleum Oil – Change   |                                      | 100,000(160,000)/–/12   |
|   | Rear Axle Wheel Ends – Inspect for leaks, lube level/condition, and check end play with dial indicator. |                                      | 100,000(160,000)/–/12 Also at brake lining service.<br><br>If wheel end play is found to be outside the 0.001 in. to 0.005 in. specification, or lube condition is contaminated or low, then perform a full wheel end tear down. Inspect bearings, spindle, and spindle nuts for excessive wear and replace as necessary. |
|   | Rear Axle with Synthetic Oil – Change   |                                      | Dana – 250,000(400,000 km)/–/36   |
|   |   |                                      | Meritor – 500,000(800,000)/–/48   |
| Rear Axle Wheel Ends – Full tear down inspection of all wheel end components, regardless of condition of lube and wheel bearing end play. |   | 500,000 miles (800,000 km)/–/5 Years |   |
| Electrical  | Engine Start and Gauge/Warning Indicators – Check   | A, B                                 |   |
|   | Instrument Readings Proper – Check  | A, B                                 |   |
|   | ABS Wiring Connections & Sensors – Reseat   | A, B                                 |   |
|   | Alternator-Starter-Battery – Check  | B                                    |   |



**Lubrication and Maintenance Interval – Recommended Synchronized Intervals (cont.)**

| <b>System</b> | <b>Item</b>   | <b>Intervals</b> | <b>Special Interval (3) : miles (km) / hours / months</b>   |
|---------------|---|------------------|---|
| Steering      | Power Steering Fluid – Check Level  | A, B             |   |
|               | Steering System – Check Tightness   | A, B             |   |
|               | Steering Gear – Lubricate dust seal (if applicable)   | A, B             | ATTN: Install grease slowly, with hand pump, at low pressure. Power grease guns may blow out dust seal. |
|               | Steering Intermediate Shaft U-Joints/Slip Joint – Lubricate                                 | A, B             |   |
|               | Steering Intermediate Shaft Joint Bolts – Check Tightness                                   |                  | 120,000 miles (193,000 km)  |
|               | Power Steering Fluid – Change   |                  | 100,000 miles (160,000 km)  |
|               | Power Steering Filter – Replace   |                  | 500,000 miles (800,000 km)  |
| Drive Shaft   | Standard U-Joints and Slip Joint (identified by non-booted slip joint) – Lubricate (NOTE 3) |                  | 15,000 miles (24,000 km)/—/3 months   |
|               | Optional SPL XL U-Joint – Lubricate   |                  | 350,000 miles (560,000 km) first lube, 100,000 miles (160,000 km) thereafter                            |
| Air Brakes    | Service Brakes Operation – Check  | A, B             |   |
|               | Parking Brakes Operation – Check  | A, B             |   |
|               | Governor Cut-in/Cut-out Pressure – Check  | A, B             |   |
|               | Brake S-Cam Bushing and Slack Adjusters – Lubricate   | A, B             |   |
|               | Air Primary and Secondary Tanks – Drain Water   | A, B             |   |
|               | Shoes-Check for Wear and Drag   | A, B             |   |
|               | Drums, Chambers, Hoses, etc. – Check for wear/damage  | A, B             |   |
|               | Brake Chamber Rod Travel – Check  | A, B             |   |
|               | Air Dryer Heater & Purge Valve – Check  | A, B             |   |

## Maintenance Intervals and Specifications

### Lubrication and Maintenance Interval – Recommended Synchronized Intervals (cont.)

| System   | Item  | Intervals | Special Interval (3) : miles (km) / hours / months   |
|--|---|-----------|--|
| Air Brakes<br>(Cont.)  | Air Compressor Discharge Line – Check for Blockage                                | A, B      |  |
|  | Brake Shoes (NOTE 3)  |           | As Required  |
|  | Air Dryer Desiccant – Replace (NOTE 3)  |           | AD-9 Model: 250,000 miles (400,000 km)/-/24<br>Other Models: 125,000 miles (200,000 km)/-/12 |
| Cooling System   | Coolant – Check Level   | A, B      |  |
|  | Radiator & CAC Fins – Check for Blockage  | A, B      |  |
|  | Coolant Concentration – Inspection/Adjustment                                     | A, B      |  |
|  | Fan Clutch – Check  | A, B      |  |
|  | Fan Blade / Shroud – Check Damage/Contact   | A, B      |  |
|  | Coolant Additive  |           | See Engine Operation and Maintenance Manual  |
|  | Extended Life Coolant – Replace   |           | See Engine Operation and Maintenance Manual  |
|  | Cooling Package External Cleaning (NOTE 3)  |           | Annually   |
|  | Coolant Filter (if equipped) – Replace  |           | See Engine Operation and Maintenance Manual  |
| Engine<br>(See Engine Operation and Maintenance Manual for complete maintenance guide) | Engine Oil Level – Check  | A, B      |  |
|  | Engine Belts and Belt Tensioner - Inspect (Replace if significantly deteriorated) | A, B      |  |
|  | Air Induction System – Check for Looseness/Leaks                                  | A, B      |  |
|  | Engine Oil and Oil Filter(s) – Replace  |           | See Engine Operation and Maintenance Manual  |
|  | On-Engine Fuel Filter   |           | See Engine Operation and Maintenance Manual  |
|  | Engine Air Filter – Replace (NOTE 3)  |           | As required by restriction gauge reading/-/1 year  |

**Lubrication and Maintenance Interval – Recommended Synchronized Intervals (cont.)**

| <b>System</b>    | <b>Item</b>  | <b>Intervals</b> | <b>Special Interval (3) : miles (km) / hours / months</b> |
|------------------|--|------------------|---|
| Fuel System      | Fuel Sender, Hose Connections – Check for Loose Connectors         | A, B             |   |
|                  | Fuel/ Water Separator – Drain Water/Dirt                           | A, B             |   |
|                  | Non-Davco Fuel/Water Separator Filter – Replace                    | A, B             | See Engine Operation and Maintenance Manual               |
|                  | Davco Fuel/Water Separator Filter – Replace                        |                  | See Engine Operation and Maintenance Manual               |
|                  | Fuel Tank(s) – Drain and flush (NOTE 3)                            |                  | 100,000 miles (160,000 km)/–/12                           |
| Exhaust System   | Pipes / Muffler - Inspect for Leakage/Looseness/Damaged Insulation | A, B             |   |
|                  | Diesel Particulate Filter (DPF) Cleaning                           |                  | As required by dash warning indicator.                    |
| Hydraulic Clutch | Release Bearing/Shfts/Fork – Lubricate                             | A, B             |   |
|                  | Hydraulic Clutch Fluid – Drain and Refill                          |                  | 200,000 miles (322,000 km)/–/2 years                      |
| Transmission     | Transmission Fluid – Check Level                                   | A, B             |   |
|                  | Shift Selector / Linkage – Check Function                          | A, B             |   |
|                  | Neutral Start Switch – Check Function                              | A, B             |   |
|                  | Transmission Fluid (Synthetic) – Replace (NOTE 3)                  |                  | 500,000 miles (800,000 km) /–/5 years                     |
|                  | Transmission Filter – Replace                                      |                  | Refer to Transmission Manual                              |
|                  | Transmission Fluid (Mineral) – Replace                             | B                | Refer to Transmission Manual                              |
| Tires/Wheels     | Wear and Condition – Check   | A, B             |   |
|                  | Wheel Stud Nuts – Retorque   | A, B             |   |
|                  | Spin Balance (NOTE 3)  |                  | At time of tire mounting and as required                  |

## Maintenance Intervals and Specifications

### Lubrication and Maintenance Interval – Recommended Synchronized Intervals (cont.)

| System         | Item   | Intervals   | Special Interval (3) : miles (km) / hours / months |
|----------------|--|-------------|--|
| Cab Components | Door Hinges/Latches/Strikers – Lubricate, Check Link (Use Multi-purpose lithium grease or light engine oil. <b>Do Not</b> use silicone lubricant). | A, B        |  |
|                | Windshield Wipers – Inspect  | A, B        |  |
|                | Door Lock Cylinders – Lubricate  | A, B        |  |
|                | Windshield Wipers – Replace  |             | 12 months or as required.                          |
|                | Seat Adjuster Slides – Lubricate (NOTE 3)  |             | 100,000 miles (160,000 km)                         |
| HVAC Filters   | Cowl HVAC Filter – Replace or Clean  |             | As required  |
|                | Sleeper HVAC Filter – Replace or Clean   |             | 50,000 miles (80,000 km)                           |
| Tires          | Tire Pressure Check/Tire Wear Check  | Daily, A, B |  |
|                | Low Air Pressure Warning Alarm – Check   | A, B        |  |

### Lubrication and Fluids Charts

**NOTE:** The components requiring lubrication and fluid check and fill diagrams are typical representations.

#### Lubrication Notes

##### **CAUTION**

**Unapproved lubricants can cause premature component failure. Refer to the Lubricants and Sealer Specification table for proper lubricants.**

- Wipe clean all dirt and debris from grease fittings before applying grease. If the fitting is not cleaned, dirt can be pushed into the component with the grease. Always fill grease to the point where old grease and contaminants are forced out from the part and only new grease comes out. If a fitting does not accept lubrication due to damage or internal stoppage, replace with a new fitting. Remove excess grease from fittings and other surfaces after applying grease.
- Some vehicles may have optional remote mounted grease zerks for the clutch cross-shafts. These fittings reduce service time by providing convenient access to clutch cross-shaft bushing grease zerks. Grease may be applied through two remote mounted grease zerks mounted to the bottom of the transmission bell housing.

#### Fluid Check and Fill Notes

##### **CAUTION**

**Use only recommended viscosity engine oil. Refer to the Engine Operation and Maintenance Manual for engine oil specifications.**

- Wait five minutes after shutting off the engine before checking the oil level. This gives the oil time to drain back to the oil pan.
- Clean all caps and fill plugs prior to removal to prevent dirt and debris from entering system.
- Filling the power steering fluid above the MAX COLD mark when cold will result in fluid overflow when hot.
- If engine is cold and coolant is above the MIN/ADD line, no additional coolant is needed. Excessive filling when cold can cause tank to overflow when hot.
- When checking the axle hub fluid level, maintain fluid level to fill line on hubcap.
- Check the rear axle(s) vent for blockage. Blockage can cause excessive pressure in the axle and create leaks.

## Maintenance Intervals and Specifications

---

### Components Requiring Lubrication

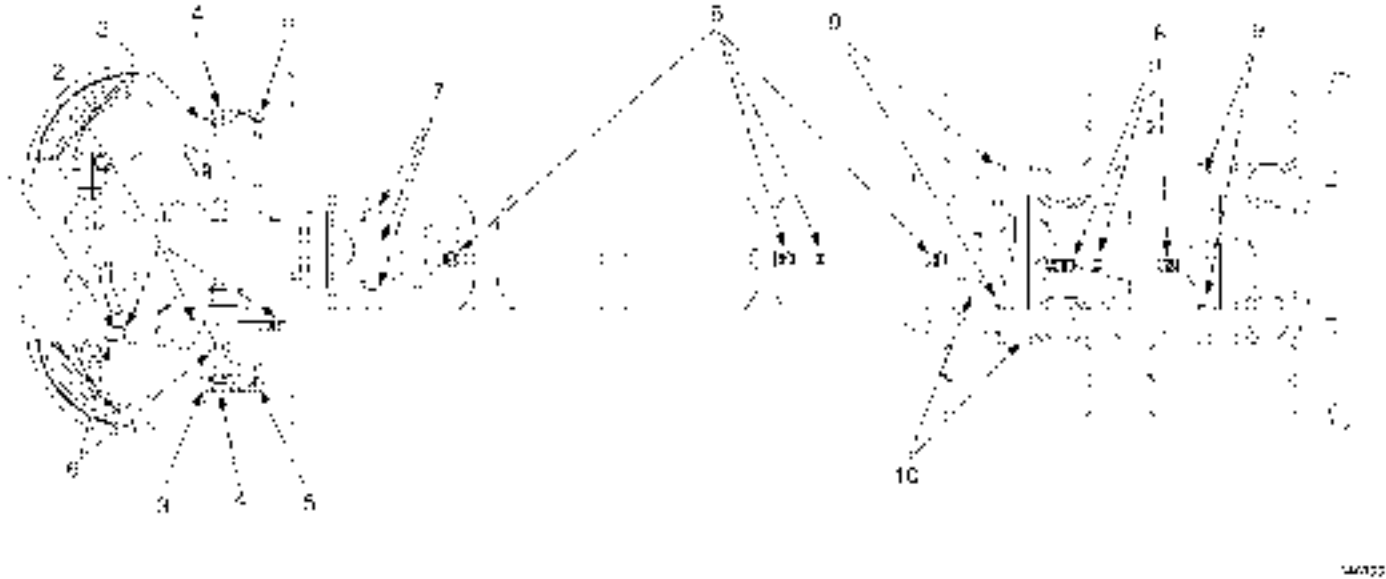

1. Steering Gear
2. Steering Intermediate Shaft
3. Front S-Cams and Slack Adjusters
4. King Pin Bushings and Thrust Bearings
5. Tie Rod Ends
6. Steering Drag Link Ends
7. Clutch Cross Shafts and Release Bearing
8. Drive Shaft U-joints and Slip Joint
9. Rear S-Cams and Slack Adjusters
10. Fifth Wheel Pivot Points and Top Plate

### Components Requiring Fluid Check and Fill

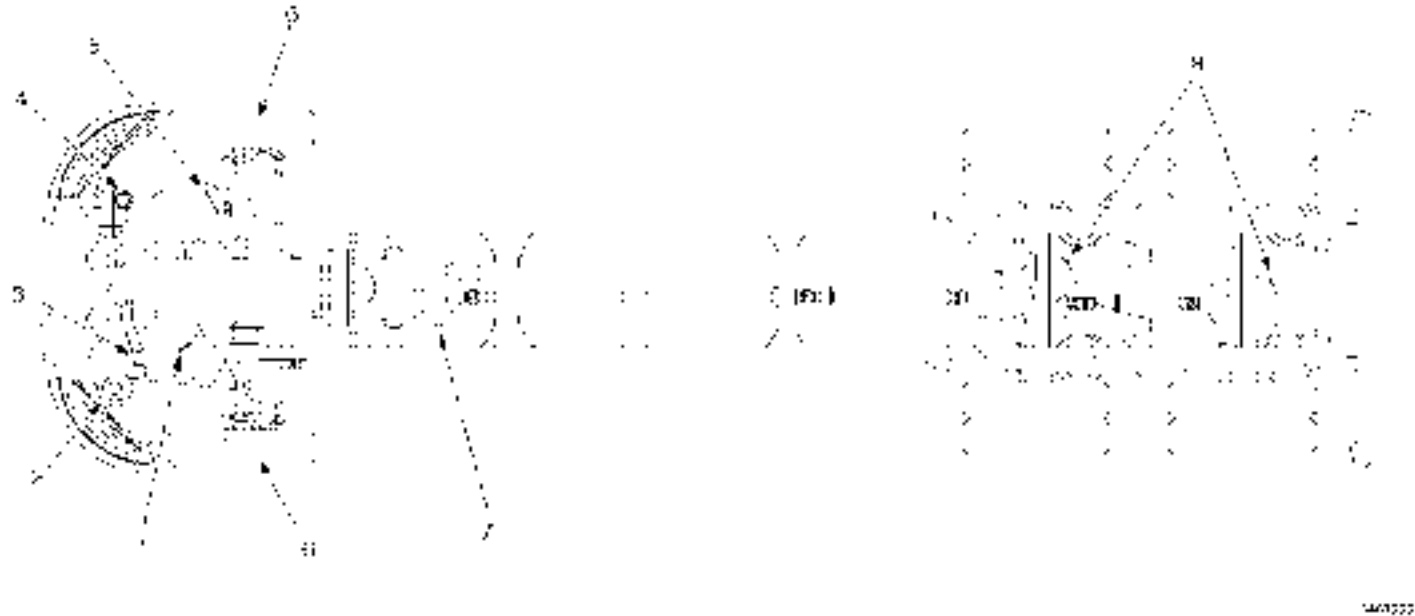

1. Engine Oil Dipstick
2. Power Steering Fluid Reservoir
3. Engine Oil Fill Tube
4. Coolant Surge Tank
5. Windshield Washer Fluid Bottle
6. Front Axle Oil-Filled Hubs
7. Transmission Oil Fill/Level Check Plug
8. Drive Axle Oil Fill/Level Check Plug

## Maintenance Intervals and Specifications

---

### Unit Refill Capacities

#### Cooling System Refill Capacities

Cooling system refill capacities vary considerably due to differences in engine models and optional equipment (including sleeper heater circuit), in addition to the amount of coolant remaining in the system after draining. Total capacity may range from 12 to 15 gallons (45 to 57 Liters). If system has been drained, fill with a 50/50 mixture of Nitrite-free Shell Rotella® Ultra Extended Life Coolant (ELC) (yellow) concentrate and demineralized or distilled water, or Nitrite-free Shell Rotella® Ultra ELC 50/50 Premix (yellow). If the system has been flushed with water or cleaner, a significant amount of the rinse water will remain in the system. In this case refilling with a mixture with a higher percentage (60 to 66%) of coolant concentrate is advised in order to achieve a final mixture closer to 50/50. Fill the system and run the vehicle until the thermostat opens. Before adding any fluid, check the coolant concentration and add additional water or concentrated undiluted coolant to adjust the concentration. Run the vehicle and retest for coolant volume level (set to "MAX" line) and concentration level.

### Crankcase and Oil Filters

For specific engine crankcase capacities, refer to separate Engine Operation and Maintenance Manual provided with vehicle.

### Hydraulic Clutch System

| Description        | Fl-Oz | Liters |
|--------------------|-------|--------|
| Reservoir Capacity | 8.45  | .25    |
| System Capacity    | 16.6  | .49    |

**NOTE:** Use only approved DOT 3 or DOT 4 brake fluid.

### Power Steering Systems

| Gear                        | Power Steering Fluid Volume (pints / liters) |
|-----------------------------|--|
| TRW PCF60 Steering Gear     | 8.4 / 3.9                                    |
| Sheppard HD94 Steering Gear | 8.4 / 3.9                                    |



### Transmission

| Description  | Transmission Type | Feature Code   | Pints | Liters |
|--|-------------------|--|-------|--------|
| Eaton Fuller® 9-Speed (synthetic transmission oil):**  | Manual            | 13GPL  | 28*   | 13*    |
| Eaton Fuller® 10-Speed (standard transmission oil):**  | Manual            | 13GAH; 13GHJ; 13GHK; 13GHL; 13GHN;<br>13GHP; 13GHR; 13GHS; 13GNB | 24*   | 11*    |
| Eaton Fuller® 10-Speed (standard transmission oil):**  | Manual            | 13GKZ  | 24*   | 11*    |
| Eaton Fuller® 10-Speed (standard transmission oil):**  | AutoShift         | 13GRN  | 24*   | 11*    |
| Eaton Fuller® 10-Speed (synthetic transmission oil):**   | AutoShift         | 13GPN; 13GPP; 13GPR; 13GPS                                       | 26*   | 12*    |
| Eaton Fuller® 10-Speed (synthetic transmission oil):**   | UltraShift        | 13GPM; 13GPW   | 26*   | 12*    |
| Eaton Fuller® 13-Speed (standard transmission oil):**  | Manual            | 13GKJ; 13GRE   | 28*   | 13*    |
| Eaton Fuller® 13-Speed (synthetic transmission oil):**   | Manual            | 13GJS  | 28*   | 13*    |
| Eaton Fuller® 13-Speed (synthetic transmission oil):**   | UltraShift        | 13GRX  | 28*   | 13*    |
| Eaton Fuller® 15-Speed (standard transmission oil):**  | Manual            | 13GHY  | 28*   | 13*    |
| Eaton Fuller® 18-Speed (standard transmission oil):**  | Manual            | 13GKK; 13GKL; 13GKM; 13GNM                                       | 28*   | 13*    |
| Eaton Fuller® 18-Speed (standard transmission oil):**  | Manual            | 13GPV  | 28*   | 13*    |
| <p>A variety of transmissions are available for the International® ProStar®+ Series truck. Refer to the Transmission Manual for required capacities and transmission oils.</p> <p>* Approximate refill quantity; less than initial fill as fluids remain in external circuits and transmission cavities.</p> <p>** Check at operating temperature and top off as required.</p> |                   |  |       |        |

## Maintenance Intervals and Specifications

### Rear Axle Unit Refill Capacities

| 4X2 SINGLE AXLE |              |       |        |
|-----------------|--------------|-------|--------|
| Description     | Feature Code | Pints | Liters |
| RS-23-160       | 14051, 14ARB | 39.5  | 18.7   |
| S23-190         | 14AHE        | 37    | 17.5   |
| RS-23-186       | 14ARX, 14ARY | 47.3  | 22.4   |

| 6X4 TANDEM AXLE   |   | Forward |        | Rear  |        |
|---|---|---------|--------|-------|--------|
| Description   | Code  | Pints   | Liters | Pints | Liters |
| RT-40-145,<br>RT-40-145P,<br>RT-40-145A   | 14GRB,<br>14GRC,<br>14GRN,<br>14GSX,<br>14GUR,<br>14HRN | 30.2    | 14.3   | 25.8  | 12.2   |
| DS405P/RS405,<br>DS404/RS404,<br>DS404P/RS404                                     | 14GEP,<br>14GER,<br>14GGG,<br>14GGJ                     | 31      | 14.7   | 28    | 13.2   |
| DST41/RST41,<br>DST40/RST40   | 14GJD,<br>14GJE,<br>14GJP                               | 31      | 14.7   | 36    | 17     |
| MT-40-143-MA-N,<br>MT-40-144-MA-N   | 14GVB,<br>14GVC,<br>14GWG,<br>14GWH                     | 30.2    | 14.3   | 31.4  | 14.9   |
| D46-170HP/R46-170H,<br>D46-170P/R46-170,<br>D46-170P/R46-170D,<br>D46-170/R46-170 | 14GJH,<br>14GJL,<br>14GJM,<br>14GJR                     | 39      | 18.5   | 37    | 17.5   |
| RT-46-160,<br>RT-46-160P  | 14GRD,<br>14GRP,<br>14GRS,<br>14HRM                     | 29.1    | 13.8   | 34.4  | 16.3   |
| RT-46-164P  | 14HRW   | 38.1    | 18     | 33.2  | 15.7   |

Lubricant and Sealer Specifications

| Component  | Component Vendor / Lubrication Type   | Viscosity  | Applicable Temperatures   |
|--|---|--|---|
| <b>Non-driving Front Axle</b>                              |   |  |   |
| Front axle wheel bearing oil                               | Mineral Oil   | 75W :<br>75W-80:<br>75W-90:<br>75W-140:<br>80W-90:<br>80W-140:<br>85W-140: | -40°F to - 15°F (-40°C to -26°C)<br>-40°F to 80°F (-40°C to 27°C)<br>-40°F to 100°F (-40°C to 38°C)<br>-40°F and above (-40°C and above)<br>-15°F to 100°F (-26°C to 38°C)<br>-15°F and above (-26°C and above)<br>10°F and above (-12°C and above) |
|  | Synthetic – Emgard® 2979 Synthetic Lubricant.<br><b>NOTE: Do not mix conventional (mineral based) lubricants with synthetic lubricants.</b>   | 50W  | All Temperatures  |
| Front Axle Tie Rod Ends, Drag Link, King Pins and Bushings | Eaton-Dana® axle, Hendrickson Steertek®, International Multi-Link axle, and Meritor axle:<br>Fleetrte® NLGI #2 Lithium Complex Based Moly grease P/N 991044C2 or equivalent GC/LB NLGI #2 Multi-purpose Lithium Complex grease<br><br><b>NOTE: Eaton-Dana® and Meritor Easy Steer axles: With chassis load on axle, force grease through thrust bearings; then with axle lifted clear of floor, force grease between king pin and bushing surfaces.</b> |  |   |

## Maintenance Intervals and Specifications

| Component   | Component Vendor / Lubrication Type   | Viscosity         | Applicable Temperatures |
|---|---|-------------------|-------------------------|
| <b>Engine</b>   |   |                   |                         |
| Engine Lubricating Oil                                      | See Engine Operation and Maintenance Manual   |                   |                         |
| <b>Steering</b>   |   |                   |                         |
| Power Steering Fluid  | Engine Oil<br><br>In extreme cold conditions (-20°F or below) replace the 15W- 40 and use power steering fluid Fleetrite® P/N CH990625C2 or equivalent. | 15W-40 Engine Oil |                         |
| Steering Gear – Lubricant                                   | Fleetrite® NLGI #2 Lithium Complex Based Moly grease P/N 991044C2 or equivalent GC/LB NLGI #2 Multi-purpose Lithium Complex grease                      |                   |                         |
| Steering Intermediate Shaft U-Joints/Slip Joint – Lubricant | Fleetrite® NLGI #2 Lithium Complex Based Moly grease P/N 991044C2 or equivalent GC/LB NLGI #2 Multi-purpose Lithium Complex grease                      |                   |                         |
| <b>Drive Shaft</b>  |   |                   |                         |
| U-Joint – Lubricant   | Fleetrite® Lithium Complex Based Moly grease P/N 991044C2 or equivalent GC/LB NLGI #2 Multi-purpose Lithium Complex grease                              |                   |                         |

## Maintenance Intervals and Specifications

| Component                                       | Component Vendor / Lubrication Type  | Viscosity   | Applicable Temperatures  |
|---|--|---|--|
| <b>Clutch</b>                                   |  |   |  |
| Release Bearing/<br>Shafts/ Fork<br>– Lubricant | Fleetrite® Lithium Complex Based Moly grease<br>P/N 991044C2 or equivalent GC/LB NLGI #2<br>Multi-purpose Lithium Complex grease |   |  |
| <b>Cooling System</b>                           |  |   |  |
| Extended Life Coolant                           | Shell Rotella® Ultra Extended Life Coolant<br>(ELC) – Type III   | See Engine Operation<br>and Maintenance<br>Manual |  |
| Heavy Duty<br>– Fully<br>Formulated<br>Coolant  | Type II (Purple) Fleetrite® P/N ZJJSCA5550   | See Engine Operation<br>and Maintenance<br>Manual |  |
| <b>Transmission</b>                             |  |   |  |
| Transmission Oil                                | Mineral Gear Oil API-GL-1 (Rust and Oxidation Inhibited) Fleetrite® P/N 991061C1<br><br>Heavy Duty Engine Oil API – CJ or CI     | SAE 90<br><br>SAE 80<br><br>SAE 50<br><br>SAE 40  | Above 0 deg. F (-18 deg. C)<br><br>Below 0 deg. F (-18 deg. C)<br><br>Above 0 deg. F (-18 deg. C)<br><br>Below 0 deg. F (-18 deg. C) |
|   | Synthetic Oil: Emgard® 2979 Synthetic Lubricant  | 50W   | All Temperatures   |

## Maintenance Intervals and Specifications

| Component                            | Component Vendor / Lubrication Type   | Viscosity | Applicable Temperatures           |
|--------------------------------------|---|-----------|-----------------------------------|
| <b>Rear Axle</b>                     |   |           |                                   |
| Rear Drive Axle(s)                   | Mineral Oil – Gear oil meeting MIL-PRF-2105E, API Mete GL-5   | 75W       | -40°F to - 15°F (-40°C to -26°C)  |
|                                      |   | 75W-80    | -40°F to 80°F (-40°C to 27°C)     |
|                                      |   | 75W-90    | -40°F to 100°F (-40°C to 38°C)    |
|                                      |   | 75W-140   | -40°F and above (-40°C and above) |
|                                      |   | 80W-90    | -15°F to 100°F (-26°C to 38°C)    |
|                                      |   | 80W-140   | -15°F and above (-26°C and above) |
|                                      |   | 85W-140   | 10°F and above (-12°C and above)  |
|                                      | Synthetic – Emgard® 2837 and Emgard® FE Synthetic Lubricant.<br><br><b>NOTE: Do not mix conventional (mineral bases) lube with synthetic oil.</b> | 75W-90    | All Temperatures                  |
| <b>Electrical</b>                    |   |           |                                   |
| Terminals – Lubricant Sealing Grease | Fleetrite® 472141-C1  |           |                                   |
| Connectors – Dielectric Grease       | NYOGEL® 760 G   |           |                                   |

**Torque Specifications**

**U-BOLT NUT TORQUE CHART**

| Feature Code  | Rear Suspension Capacity and Type   | Torque   |         |
|---|---|----------|---------|
|   |   | lbf - ft | N • m   |
| 14SAN   | 23,500-lb (10,659 kg) Capacity, RR, Springs, Single, Vari-Rate  | 260-300  | 353-407 |
| 14SAU   | 20,000-lb (9072 kg) Capacity, RR, Springs Multileaf with Single Torque Rod  | 258-295  | 350-400 |
| 14SAW   | 23,000-lb (10,433 kg) Capacity, RR, Springs Multileaf with Single Torque Rod  | 260-300  | 353-407 |
| 14TBJ   | 20,000-lb (9072 kg) Capacity, International Air Suspension (IROS) for axles 14ADN, 14ADP,14AJC,14AJE, 14ATP, and 14ATR. | 260-300  | 353-407 |
|   | 20,000-lb (9072 kg) Capacity, International Air Suspension (IROS) for all other axles.                                  | 370-400  | 502-542 |
| 14UNL, 14UNM, 14UNN, 14UNS, 14UNT, and 14UNU  | 40,000-lb (18,144 kg) Capacity, International Air Suspension (IROS)   | 370-400  | 502-542 |
| <b>NOTE:</b> For all other vendor supplied suspensions, refer to vendor's website for proper torque specifications. |   |          |         |

| Feature Code | Front Suspension Capacity and Type                          | Torque   |         |
|--------------|---|----------|---------|
|              |   | lbf - ft | N • m   |
| 3ADC         | 12,000-lb (5443 kg) Capacity, Parabolic Taper Leaf          | 260-300  | 353-407 |
| 3ADD         | 14,000-lb (6350 kg) Capacity, Parabolic Taper Leaf          | 260-300  | 353-407 |
| 3AGV         | 12,000-lb (5443 kg) Capacity, Monoleaf (Hendrickson Softek) | 260-300  | 353-407 |
| 3AHM         | 12,350-lb (5602 kg) Capacity, Monoleaf (Hendrickson Softek) | 260-300  | 353-407 |

## Maintenance Intervals and Specifications

| Feature Code  | Front Suspension Capacity and Type                 | Torque   |         |
|---|--|----------|---------|
|   |  | lbf - ft | N • m   |
| 3AHN  | 12,350-lb (5602 kg) Capacity, Parabolic Taper Leaf | 260-300  | 353-407 |
| <b>NOTE:</b> For all other vendor supplied suspensions, refer to vendor's website for proper torque specifications. |  |          |         |

### DISC WHEEL NUT TORQUE CHART

| Lug Nut Size  | Lug Nut Type | Socket Size | Torque    |           |
|---|--------------|-------------|-----------|-----------|
|   |              |             | lbf - ft  | N • m     |
| 22 mm   | 2 piece      | 33 mm       | 450 - 500 | 610 - 678 |
| NOTE: Do not use lubrication on dry threads. Where excessive corrosion exists, a light coat of lubricant on the first three threads of stud is permitted. Keep lubricant away from nut and rim clamp contact surfaces |              |             |           |           |

### Fuse Charts

The following fuse illustrations represent typical fuse panel layouts. The actual vehicle fuse panels will vary depending on the vehicle options. Refer to the chart on rear side of fuse cover.



Typical Interior Fuse Panel Layout



| Row | Slot | Fuse Type | Rating | Component       |
|-----|------|-----------|--------|-----------------|
| 1   | 1    | 15A       | 15A    | Battery         |
| 1   | 2    | 20A       | 20A    | Alternator      |
| 1   | 3    | 30A       | 30A    | Headlights      |
| 1   | 4    | 40A       | 40A    | Ignition        |
| 1   | 5    | 50A       | 50A    | Wipers          |
| 1   | 6    | 60A       | 60A    | Power Windows   |
| 1   | 7    | 70A       | 70A    | Power Locks     |
| 1   | 8    | 80A       | 80A    | Power Seats     |
| 1   | 9    | 90A       | 90A    | Power Mirrors   |
| 1   | 10   | 100A      | 100A   | Power Steering  |
| 2   | 1    | 15A       | 15A    | Interior Lights |
| 2   | 2    | 20A       | 20A    | Exterior Lights |
| 2   | 3    | 30A       | 30A    | Radio           |
| 2   | 4    | 40A       | 40A    | Antenna         |
| 2   | 5    | 50A       | 50A    | Blower Motor    |
| 2   | 6    | 60A       | 60A    | Water Pump      |
| 2   | 7    | 70A       | 70A    | AC Compressor   |
| 2   | 8    | 80A       | 80A    | ECU             |
| 2   | 9    | 90A       | 90A    | ABS             |
| 2   | 10   | 100A      | 100A   | Brake System    |

## Maintenance Intervals and Specifications

### Typical Luggage Compartment Fuse Panel Layout

|                                      |                          |                          |                                  |                          |  |
|--------------------------------------|--------------------------|--------------------------|----------------------------------|--------------------------|--|
| 10A SLEEPER DOME LIGHTS              | POWER SOURCE<br>270A     | 10A<br>4000C             | 10A (OPT)<br>SLEEPER DOME LIGHTS |                          |  |
| 10A ACCENT LIGHTS                    |                          |                          |                                  |                          |  |
| 15A TV POWER                         |                          |                          |                                  |                          |  |
| 10A (OPT) REFR. GENERATOR            | ACCESSORY RELAY          | SLEEPER DOME LIGHT RELAY | LUGGAGE LIGHT RELAY              | NEUTRAL HOOD RELAY (OPT) |  |
| 10A (OPT) REFR. BUNK WASHDOWN LIGHTS |                          |                          |                                  |                          |  |
|                                      |                          |                          |                                  |                          |  |
|                                      | REMOTE START RELAY (OPT) | REMOTE STOP RELAY (OPT)  |                                  |                          |  |

8487191

**ProStar®+ Series Light Information**

| Lamp Description            | Bulb P/N  |
|-----------------------------|---|
| Sleeper Dome Lamp           | F15T8/CW  |
| Day Cab Dome Lamp           | 212   |
| Cab Dome Lamp               | 577   |
| Accent Lamps                | 577   |
| Under Bunk Lamp             | 577   |
| Cab Floor Lamp              | W5W   |
| Sleeper Floor Lamp          | W5W   |
| Sleeper Reading Lamp        | 912   |
| Wardrobe Cabinet Lamp       | 7575  |
| Cab Map Lamp                | 912   |
| Door Lamps                  | W5W   |
| Clearance/Marker Lamp (LED) | 168   |
| Stop/Turn/Tail Lamp (LED)   | International® ProStar®+ Series: Truck Lite Super 40 (Truck Lite Super 44 Optional) |
| Back Up Lamp (LED)          | Truck Lite Super 40   |
| Work Light                  | 4411  |

## Maintenance Intervals and Specifications

---

| Lamp Description                   | Bulb P/N             |
|------------------------------------|----------------------|
| Headlight                          | Low Beam: 9006       |
|                                    | High Beam: 9005      |
|                                    | Side Marker: 194     |
|                                    | Parking/Turn: 3357AK |
| Side Turn and Marker Lamp assembly | 01-5242              |
| Side Turn Lamp (Incandescent)      | 3156                 |

### Filter List

Filter part numbers and/or specifications may change during the life-cycle of this vehicle. Current information on the appropriate chassis and engine filters for your vehicle can be obtained by contacting your local International dealer Parts department. (If you need assistance finding a local International dealer, use the Dealer Locator icon at [internationaltrucks.com](http://internationaltrucks.com))

---

## SECTION 9 — CUSTOMER ASSISTANCE

### Service Information

The continued premium performance of this International® chassis can best be assured through proper servicing. This can be accomplished in several ways.

**International Truck Dealers** ... Your local International Truck dealer provides an excellent resource – through his knowledgeable, experienced, and well equipped service staff – to handle all your maintenance, repair, and replacement work.

**Service Publications** ... Those persons who are properly trained technicians with the facilities, equipment, tools, safety instructions and know-how to properly and safely service a bus, medium duty and/or heavy duty chassis can purchase the appropriate service manual sections applicable to specific vehicle components or areas of this International® vehicle. Engine diagnostic manuals and engine service manuals for all current International® diesel engines are also available to these trained persons for purchase. Information on the purchase of available service publications for this chassis can be found on the internationaltrucks.com Web site, or by contacting your local International dealer.

These service resources are also available via the Internet, by an annual subscription to the **Fleet ISIS® Web site**, or via the **iService DVD**. Information on the Fleet ISIS Web site's content,

availability, and fee structure can be obtained by contacting your local International Truck dealer or, in the case of a National Account, an International Fleet Service Manager.

The iService DVD contains all currently available chassis and component service information, including TSI letters, Electrical Circuit Diagrams, Electrical System Troubleshooting and other technical information, for virtually all International® models and MaxxForce® engines.

### International Truck Warranty Program

#### **Standard Warranty • Optional Service Contracts • Custom Service Contracts • Performance PM® Service**

The International Truck Warranty Program provides International customers with a better choice when it comes to Standard Warranty and Service Contract Coverage. The **Standard Warranty** is the first tier of the International Truck Warranty Program. It provides the foundation for all extended coverages.

Vehicle Coverage, Towing, Engine and Engine Electronics, Major Component, and Pre-Packaged System Component protection can be obtained under the International Warranty Program through **Optional Service Contracts**.

## Customer Assistance

---

**Custom Service Contracts**, the most flexible aspect of the International Truck Warranty Program, can provide extended protection that is specifically tailored to meet each customer's specific requirements.

Finally, through **Performance PM® Service**, customers can obtain a comprehensive preventative maintenance program designed to ensure consistency in pricing and the level of service received.

### ADVANTAGES of International Truck Warranties

- Extends warranty protection to specified length and component coverage to suit individual needs
- Honored at over 1,000 International Truck Dealer locations in North America
- Stabilized and predictable maintenance costs
- Increased owner confidence and peace of mind
- Improved resale value on your vehicle – International Truck Warranties may be transferable for a nominal fee. Contact the Service Contract Center 1-800-346-4429 option 1 for transferability
- Most coverage is 100% parts and labor with **NO DEDUCTIBLES** .
- Customized warranty programs are offered to suit your needs - your specification - your vocation

- International, North America's leader in truck manufacturing, is also North America's leader in warranty value
- Optional Service Contracts, Custom Service Contracts, and Performance PM® Service, designed to assure the lowest possible cost of ownership, are also available
- **Optional Service Contracts** have been pre-packaged to fit most common applications
- **Custom Service Contracts** are designed to meet your individual needs

### HOW TO OBTAIN International Truck Warranties

- **Standard Warranty:** Your new International® vehicle is automatically registered in the International Truck Warranty system at the time of delivery. No further action on your part is required.
- **Optional Service Contracts, Custom Service Contracts, or Performance PM® Service:** These programs are sold exclusively through your International dealer. The vehicle must also have coverage remaining under the Standard Warranty. For extended warranty purchases between, 181 through 365 days from DTU and <100,000 miles (160,000 km) an additional fee will be assessed. If you would like the predictable cost of ownership and peace of mind provided by the International Truck Warranty Program, please contact your International dealer today!

## SECTION 10 — INDEX

## A

|   |          |
|---|----------|
| ABS Connections and Sensors.....                              | 182      |
| ABS Operation.....  | 158      |
| ABS Self Check.....   | 159      |
| Accent Light Dimmer Switch.....                               | 99       |
| Accent Light Switch.....                                      | 99       |
| Accent Lights.....  | 97       |
| Accessory Feed Connections.....                               | 186      |
| Additional Unsafe Practices.....                              | 137      |
| Adjustable Belts.....   | 103      |
| Adjustable Steering Column.....                               | 129      |
| After the Engine Starts.....                                  | 124      |
| Air Brakes.....   | 152, 179 |
| Air Gauge, Low Air Pressure Beeper and Warning Indicator..... | 153      |
| Brake Application.....  | 154      |
| Inspection and Adjustment.....                                | 179      |
| Reservoir Moisture Draining.....                              | 153      |
| Air Cleaner Element Service.....                              | 189      |
| Air Compressor Cycling.....                                   | 135      |
| Air Conditioning.....   | 88       |
| Air Conditioning Service Checks.....                          | 174      |
| Front Access HVAC Filter.....                                 | 175      |
| HVAC Filters.....   | 174      |
| Recirculation Filters.....                                    | 175      |
| Side Access HVAC Filter.....                                  | 174      |
| Sleeper HVAC Filter.....                                      | 176      |
| Air Dryer.....  | 155, 180 |
| Desiccant Filter.....   | 181      |
| Heater.....   | 181      |

## A (CONT.)

|   |     |
|---|-----|
| <i>Air Dryer (cont.)</i>  |     |
| Purge Valve.....  | 181 |
| Air Gauge, Low Air Pressure Beeper and Warning Indicator.....     | 153 |
| Air Induction System.....   | 187 |
| Air Intake System.....  | 196 |
| Air Reservoir/Tanks Moisture Draining.....                        | 181 |
| Air Restriction Gauge.....  | 188 |
| Air Suspension System Faults.....                                 | 151 |
| Airline Cabinets.....   | 114 |
| Alignment.....  | 177 |
| Alternator.....   | 130 |
| Antifreeze.....   | 194 |
| Antilock Brake System (ABS).....                                  | 158 |
| ABS Operation.....  | 158 |
| ABS Self Check.....   | 159 |
| Antilock Driving Tips.....  | 159 |
| Antilock Driving Tips.....  | 159 |
| Assistance Guide.....   | 1   |
| ATC OFF ROAD or MUD/SNOW Switch.....                              | 160 |
| ATC System Check.....   | 160 |
| Automatic Door Lock Function.....                                 | 91  |
| Automatic Traction Control (ATC) System.....                      | 159 |
| ATC OFF ROAD or MUD/SNOW Switch.....                              | 160 |
| ATC System Check.....   | 160 |
| Stability Control Systems – Bendix® RSP/WABCO RSC/Bendix ESP..... | 160 |
| Available Models.....   | 9   |
| Axles.....  | 176 |

# Index

---

## A (CONT.)

|                                 |     |
|---------------------------------|-----|
| <i>Axles (cont.)</i>            |     |
| Front Axle.....                 | 176 |
| Alignment.....                  | 177 |
| Inspection and Lubrication..... | 176 |
| Normal Maintenance.....         | 177 |
| Locking Differential.....       | 178 |
| Rear Axle.....                  | 177 |
| Inspection and Lubrication..... | 177 |

## B

|   |          |
|---|----------|
| Base Display.....   | 89       |
| Batteries.....  | 184      |
| Battery.....  | 130      |
| Battery Cables.....   | 185      |
| BATTERY ON Indicator.....                                     | 131      |
| Bobtail Proportioning System.....                             | 157      |
| Body.....   | 196      |
| Brake Application.....  | 154      |
| Brakes.....   | 151, 178 |
| ABS Connections and Sensors.....                              | 182      |
| Air Brakes.....   | 152, 179 |
| Air Gauge, Low Air Pressure Beeper and Warning Indicator..... | 153      |
| Brake Application.....  | 154      |
| Inspection and Adjustment.....                                | 179      |
| Reservoir Moisture Draining.....                              | 153      |
| Air Dryer.....  | 155, 180 |
| Desiccant Filter.....   | 181      |
| Heater.....   | 181      |
| Purge Valve.....  | 181      |
| Air Reservoir/Tanks Moisture Draining.....                    | 181      |

## B (CONT.)

|  |     |
|--|-----|
| <i>Brakes (cont.)</i>                                      |     |
| Antilock Brake System (ABS).....                           | 158 |
| ABS Operation.....   | 158 |
| ABS Self Check.....  | 159 |
| Antilock Driving Tips.....                                 | 159 |
| Bobtail Proportioning System.....                          | 157 |
| Downhill Operation.....                                    | 152 |
| Parking Brake.....   | 154 |
| Parking Brake Alarm.....                                   | 155 |
| Parking Brake Reset.....                                   | 155 |
| Parking Brake Indicator.....                               | 157 |
| Trailer Air Supply and Parking Brake Modular Controls..... | 156 |
| Trailer Brake Hand Control.....                            | 155 |
| Bright Metal Care.....                                     | 182 |
| Bunk Restraint System.....                                 | 103 |
| Adjustable Belts.....                                      | 103 |
| Restraint Webbing System.....                              | 103 |

## C

|   |     |
|---|-----|
| Cab.....  | 182 |
| Care of Vehicle.....                            | 182 |
| Bright Metal Care.....                          | 182 |
| Exposed Rubber and Unpainted Plastic Parts..... | 182 |
| Upholstery Care.....                            | 182 |
| Washing and Waxing.....                         | 182 |
| Cab Controls.....                               | 118 |
| Cab Doors and Locks.....                        | 90  |
| Cab Entry and Exit.....                         | 18  |
| Cab Interior Inspection.....                    | 41  |
| Cabinets.....                                   | 110 |
| Airline Cabinets.....                           | 114 |



| <b>C (CONT.)</b>                                   | <b>C (CONT.)</b>   |
|--|--|
| <i>Cabinets (cont.)</i>                            | Checking Inflation.....201                               |
| Dresser Cabinet.....111                            | Circuit Breakers, Fuses and Fusible Links.....131        |
| Horizontal Refrigerator.....111                    | Cleaning.....197   |
| Rear Wardrobe Cabinet.....113                      | Climate Control.....86                                   |
| Refrigerator Cabinet.....110                       | Air Conditioning.....88                                  |
| Tower Wardrobe Cabinet.....112                     | Dehumidification.....89                                  |
| Cabinets/Storage.....109                           | Clutch.....183   |
| Canadian Registered Vehicles.....5                 | Hydraulic Clutch.....183                                 |
| Care of Seat Belts.....120                         | Pedal Free Travel.....183                                |
| Care of Vehicle.....182                            | Clutch Brake.....148                                     |
| Bright Metal Care.....182                          | Clutch Precautions.....145                               |
| Exposed Rubber and Unpainted Plastic Parts.....182 | Cold Weather.....125                                     |
| Upholstery Care.....182                            | Cold Weather Operation.....126                           |
| Washing and Waxing.....182                         | Cold Weather Starting.....125                            |
| Cautions and Warnings.....1                        | Engine Idle Shutdown Timer (Optional).....127            |
| Center Dash Panel/Wing Panel.....81                | Engine Idling.....126                                    |
| Climate Control.....86                             | Winter Front Usage.....127                               |
| Air Conditioning.....88                            | Cold Weather Operation.....126                           |
| Dehumidification.....89                            | Cold Weather Starting.....125                            |
| Gauges.....82                                      | Compass Declination Zone Set Procedure.....57            |
| Switches.....82                                    | Compass Directional Calibration Procedure.....60         |
| Certified Clean Idle.....134                       | Component Code Numbers.....2                             |
| Charge Air Cooler.....132                          | Line Set Ticket.....2                                    |
| Charge Air Cooler And Radiator Core Inspection And | Components Requiring Fluid Check and Fill.....219        |
| Cleaning.....192                                   | Components Requiring Lubrication.....218                 |
| Inspection and Cleaning.....192                    | Connecting/Disconnecting a Trailer to a Vehicle with Air |
| Chassis Lubrication.....173                        | Suspension.....166                                       |
| Chassis Skirts.....21                              | Convenience Features.....115                             |
| Extended Chassis Skirts.....22                     | Floor Covering.....115                                   |
| Installation.....22                                | Power Inverter.....115                                   |
| Removal.....21                                     | Power Sockets.....115                                    |

# Index

---

## C (CONT.)

|   |     |
|---|-----|
| <i>Convenience Features (cont.)</i>                   |     |
| Sleeper Curtain.....                                  | 115 |
| Sleeper Fan.....                                      | 115 |
| Speakers.....   | 115 |
| Television Mount.....                                 | 115 |
| Coolant and Optional Coolant Filter.....              | 194 |
| Coolant Concentration Freeze Point.....               | 194 |
| Coolant Level Check.....                              | 192 |
| Cooling System.....                                   | 192 |
| Antifreeze.....                                       | 194 |
| Coolant and Optional Coolant Filter.....              | 194 |
| Coolant Concentration Freeze Point.....               | 194 |
| Coolant Level Check.....                              | 192 |
| Fan Clutch.....                                       | 194 |
| Filling Instructions.....                             | 192 |
| Cooling System Refill Capacities.....                 | 220 |
| Courtesy Lights.....                                  | 76  |
| Crankcase and Oil Filters.....                        | 220 |
| Crankcase Ventilation Filter.....                     | 195 |
| Cruise Control.....                                   | 78  |
| Customer Security Guide for International Trucks..... | 6   |

## D

|                                      |     |
|--------------------------------------|-----|
| Dash Components.....                 | 44  |
| Daytime Running Lights (DRL).....    | 75  |
| Dehumidification.....                | 89  |
| Desiccant Filter.....                | 181 |
| Diesel Particulate Filter (DPF)..... | 196 |
| Cleaning.....                        | 197 |
| Regeneration.....                    | 196 |
| Direct Drive Warning Indicators..... | 54  |

## D (CONT.)

|  |     |
|--|-----|
| Disc Wheel Nut Torque Chart.....               | 228 |
| Dome Light.....                                | 97  |
| Dome Lighting.....                             | 76  |
| Door and Window Controls.....                  | 90  |
| Door Lock/Unlock.....                          | 90  |
| Automatic Door Lock Function.....              | 91  |
| Cab Doors and Locks.....                       | 90  |
| Lock/Unlock From Interior.....                 | 91  |
| Remote Keyless Entry Operation (Optional)..... | 90  |
| Driver/Passenger Windows.....                  | 91  |
| Manual Operation.....                          | 91  |
| Mirror Controls.....                           | 92  |
| Power Operation.....                           | 92  |
| Vent Window.....                               | 92  |
| Window Lockout Function.....                   | 92  |
| Door Lock/Unlock.....                          | 90  |
| Automatic Door Lock Function.....              | 91  |
| Cab Doors and Locks.....                       | 90  |
| Lock/Unlock From Interior.....                 | 91  |
| Locking the Door.....                          | 91  |
| Unlocking the Door.....                        | 91  |
| Remote Keyless Entry Operation (Optional)..... | 90  |
| Double Clutch Procedures.....                  | 145 |
| Downhill Operation.....                        | 152 |
| Dresser Cabinet.....                           | 111 |
| Drive Shafts.....                              | 197 |
| Driver and Passenger Side.....                 | 21  |
| Driver Controlled Differential Lock.....       | 150 |
| Driver Reward.....                             | 93  |
| Driver/Passenger Windows.....                  | 91  |
| Manual Operation.....                          | 91  |

**D (CONT.)**

|   |     |
|---|-----|
| <i>Driver/Passenger Windows (cont.)</i> |     |
| Mirror Controls.....                    | 92  |
| Power Operation.....                    | 92  |
| Vent Window.....                        | 92  |
| Window Lockout Function.....            | 92  |
| Dual Tires Matching.....                | 203 |
| Dual Tires Mixing.....                  | 203 |

**E**

|  |          |
|--|----------|
| Eaton AutoShift® Transmissions (Optional).....         | 146      |
| Eaton UltraShift® Transmissions (Optional).....        | 148      |
| Eaton VORAD Collision Warning System (Optional).....   | 93       |
| Driver Reward.....                                     | 93       |
| System Description.....                                | 93       |
| Electrical.....  | 130, 184 |
| Accessory Feed Connections.....                        | 186      |
| Alternator.....  | 130      |
| Batteries.....   | 184      |
| Battery.....   | 130      |
| Battery Cables.....                                    | 185      |
| BATTERY ON Indicator.....                              | 131      |
| Circuit Breakers, Fuses and Fusible Links.....         | 131      |
| Electrical Charging and Starting System Test.....      | 185      |
| Electrical Load Control and Shedding (ELCS).....       | 132      |
| Fuses and Relays.....                                  | 186      |
| Terminal Inspection-Cleaning-Corrosion Protection..... | 185      |
| Electrical Charging and Starting System Test.....      | 185      |
| Electrical Load Control and Shedding (ELCS).....       | 132      |
| Electrical System.....                                 | 43       |
| Electronic Climate Controller.....                     | 100      |
| Electronic Engine Controller.....                      | 133      |

**E (CONT.)**

|   |          |
|---|----------|
| Electronic Vehicle Monitoring.....                                  | 89       |
| Base Display.....   | 89       |
| Premium Display.....  | 89       |
| Emergency Starting.....   | 124      |
| Emission Control Systems.....                                       | 5        |
| Engaging the Clutch.....  | 143      |
| Engine.....   | 132, 186 |
| Air Cleaner Element Service.....                                    | 189      |
| Air Compressor Cycling.....   | 135      |
| Air Induction System.....   | 187      |
| Air Restriction Gauge.....  | 188      |
| Certified Clean Idle.....   | 134      |
| Charge Air Cooler.....  | 132      |
| Charge Air Cooler And Radiator Core Inspection And<br>Cleaning..... | 192      |
| Inspection and Cleaning.....  | 192      |
| Cooling System.....   | 192      |
| Antifreeze.....   | 194      |
| Coolant and Optional Coolant Filter.....                            | 194      |
| Coolant Concentration Freeze Point.....                             | 194      |
| Coolant Level Check.....  | 192      |
| Fan Clutch.....   | 194      |
| Filling Instructions.....   | 192      |
| Crankcase Ventilation Filter.....                                   | 195      |
| Electronic Engine Controller.....                                   | 133      |
| Engine Brake.....   | 133      |
| Engine fluids and contaminated material.....                        | 187      |
| Engine Oil.....   | 136      |
| Engine Performance Problems.....                                    | 136      |
| Fuel System.....  | 195      |
| Fuel Tank Draining and Cleaning.....                                | 195      |

## *E (CONT.)*

### *Engine (cont.)*

|  |     |
|--|-----|
| MaxxFORCE® 11, 13 and 15 Engine Brake With Eaton AutoShift®/UltraShift® Transmissions Special Driver Instructions..... | 133 |
| MaxxFORCE® Engine Features.....  | 134 |
| Scheduled Maintenance.....   | 187 |
| Self Diagnostics.....  | 134 |
| Troubleshooting.....   | 191 |
| Engine Brake.....  | 133 |
| Engine Control Switch.....   | 99  |
| Engine fluids and contaminated material.....   | 187 |
| Engine Idle Shutdown Timer (Optional).....   | 127 |
| Engine Idling.....   | 126 |
| Engine Noise Shields/Blankets.....   | 196 |
| Engine Oil.....  | 136 |
| Engine Performance Problems.....   | 136 |
| Engine Serial Number.....  | 13  |
| Engine Shutdown.....   | 124 |
| Engine Starting.....   | 123 |
| Entering The Upper Bunk.....   | 107 |
| Exhaust Diesel Particulate Filter Regeneration.....  | 139 |
| Parked Regeneration Procedure.....   | 141 |
| Regeneration Inhibit Switch.....   | 141 |
| Three-Position Regeneration Inhibit Switch.....  | 142 |
| Two-Position Regeneration Inhibit Switch.....  | 142 |
| Exhaust System.....  | 196 |
| Exiting The Upper Bunk.....  | 108 |
| Exposed Rubber and Unpainted Plastic Parts.....  | 182 |
| Extended Chassis Skirts.....   | 22  |
| Exterior Components.....   | 14  |
| Exterior Lights Check.....   | 24  |

## *E (CONT.)*

|                               |   |
|-------------------------------|---|
| Exterior Noise Emissions..... | 4 |
|-------------------------------|---|

## **F**

|  |     |
|--|-----|
| Fan Clutch.....                          | 194 |
| Feature Codes.....                       | 12  |
| Fifth Wheel and Coupling Area.....       | 40  |
| Fifth Wheel Jaw Monitoring.....          | 169 |
| Fifth Wheel Jaw Unlock Control.....      | 168 |
| Fifth Wheel Operation.....               | 166 |
| Fifth Wheel Jaw Monitoring.....          | 169 |
| Fifth Wheel Jaw Unlock Control.....      | 168 |
| Fifth Wheel Slide Switch (Optional)..... | 167 |
| Hook-Up.....                             | 167 |
| Un-Hook.....                             | 168 |
| Fifth Wheel Slide Switch (Optional)..... | 167 |
| Filling Instructions.....                | 192 |
| Filter List.....                         | 232 |
| Floor Covering.....                      | 115 |
| Floor Lights.....                        | 97  |
| Frame.....                               | 195 |
| Front Access HVAC Filter.....            | 175 |
| Front Axle.....                          | 176 |
| Alignment.....                           | 177 |
| Inspection and Lubrication.....          | 176 |
| Normal Maintenance.....                  | 177 |
| Front of Tractor.....                    | 29  |
| Front Suspension.....                    | 197 |
| Fuel.....                                | 137 |
| Additional Unsafe Practices.....         | 137 |
| Fuel and Lubricant Additives.....        | 137 |
| Fueling Precautions.....                 | 138 |

|  |        |  |         |
|--|--------|--|---------|
| <b>F (CONT.)</b>                                   |        | <b>H (CONT.)</b>   |         |
| <i>Fuel (cont.)</i>                                |        | Hook-Up.....   | 167     |
| Fueling Procedures.....                            | 137    | Horizontal Refrigerator.....   | 111     |
| Hazards of Diesel Fuel/Gasoline Blends.....        | 137    | Hot Weather Operation.....   | 127     |
| Reserve Fuel.....                                  | 138    | Hub-Piloted Wheel Installation Procedures.....                             | 206     |
| Ultra Low Sulfur Diesel Fuel Requirements.....     | 137    | HVAC Filters.....  | 174     |
| Unacceptable Fuel Blends.....                      | 137    | Hydraulic Clutch.....  | 183     |
| Fuel and Lubricant Additives.....                  | 137    | Hydraulic Clutch Actuation System.....                                     | 144     |
| Fuel System.....                                   | 195    | Hydraulic Clutch System.....   | 220     |
| Fuel Tank Draining and Cleaning.....               | 195    |  |         |
| Fuel Tank Draining and Cleaning.....               | 195    | <b>I</b>   |         |
| Fueling Precautions.....                           | 138    | Inspection.....  | 202     |
| Fueling Procedures.....                            | 137    | Inspection and Adjustment.....   | 179     |
| Fuse Charts.....                                   | 228    | Inspection and Cleaning.....   | 192     |
| Filter List.....                                   | 232    | Inspection and Lubrication.....  | 176–177 |
| ProStar®+ Series Light Information.....            | 231    | Installation.....  | 22      |
| Typical Interior Fuse Panel Layout.....            | 229    | Installing Axle Shafts.....  | 165     |
| Typical Luggage Compartment Fuse Panel Layout..... | 230    | Instructions for Proper Maintenance.....                                   | 196     |
| Fuses and Relays.....                              | 186    | Instrument Panel Gauge Cluster.....  | 46      |
|  |        | Direct Drive Warning Indicators.....                                       | 54      |
| <b>G</b>   |        | Gauges.....  | 50      |
| Gauges.....  | 50, 82 | Instrument Panel Gauge Cluster Alarms.....                                 | 52      |
| General Text and Warning Messages.....             | 56     | Integral Digital Display.....  | 54      |
|  |        | General Text and Warning Messages.....                                     | 56      |
| <b>H</b>   |        | Integral Digital Display Detailed Information.....                         | 62      |
| Hazards of Diesel Fuel/Gasoline Blends.....        | 137    | Optional Instrument panel gauge cluster Compass Calibration Procedure..... | 57      |
| Headlights.....                                    | 75     | Compass Declination Zone Set Procedure.....                                | 57      |
| Heater.....  | 181    | Compass Directional Calibration Procedure.....                             | 60      |
| High Restriction Reading Table.....                | 191    | Switches.....  | 75      |
| Hood.....  | 18     | Courtesy Lights.....   | 76      |
| Lowering the Hood.....                             | 19     | Daytime Running Lights (DRL).....  | 75      |
| Raising the Hood.....                              | 18     |  |         |

# Index

---

## I (CONT.)

|  |     |
|--|-----|
| <i>Instrument Panel Gauge Cluster (cont.)</i>            |     |
| Dome Lighting.....                                       | 76  |
| Headlights.....  | 75  |
| Lights On With Wipers.....                               | 75  |
| Panel Lighting.....                                      | 75  |
| Park Lights.....   | 75  |
| Warning Indicators.....                                  | 48  |
| Instrument Panel Gauge Cluster Alarms.....               | 52  |
| Integral Digital Display.....                            | 54  |
| General Text and Warning Messages.....                   | 56  |
| Integral Digital Display Detailed Information.....       | 62  |
| Outside Temperature and Compass Displays (Optional)..... | 74  |
| Outside Temperature Reading.....                         | 74  |
| Quadrant 1: Informational Displays.....                  | 62  |
| Quadrant 2: Text and Warning Messages.....               | 67  |
| Quadrant 3: Display Messages.....                        | 74  |
| Quadrant 4: Transmission Gear Displays.....              | 75  |
| Warning Messages.....                                    | 74  |
| International Truck Warranty Program.....                | 233 |
| Introduction   |     |
| Electrical System.....                                   | 43  |
| Main Features.....                                       | 95  |
| Irregular Wear.....                                      | 205 |

## L

|                              |    |
|------------------------------|----|
| Left Engine Compartment..... | 26 |
| Left Front of Tractor.....   | 27 |
| Left Rear of Tractor.....    | 38 |
| Left Side Cab Area.....      | 25 |
| Lighting.....                | 97 |

## L (CONT.)

|   |       |
|---|-------|
| <i>Lighting (cont.)</i>                                     |       |
| Accent Lights.....  | 97    |
| Dome Light.....   | 97    |
| Floor Lights.....   | 97    |
| Reading Lights.....   | 97    |
| Lights On With Wipers.....                                  | 75    |
| Line Set Ticket.....  | 2, 13 |
| Loads.....  | 203   |
| Lock/Unlock From Interior.....                              | 91    |
| Locking the Door.....                                       | 91    |
| Unlocking the Door.....                                     | 91    |
| Locking Differential.....                                   | 178   |
| Locking or Limited Slip Differentials.....                  | 148   |
| Locking the Door.....                                       | 91    |
| Lower Bunk.....   | 105   |
| Lowering the Hood.....                                      | 19    |
| Lowering the Tilt-Away Bumper.....                          | 20    |
| Lubricant and Sealer Specifications.....                    | 223   |
| Lubrication and Fluids Charts.....                          | 217   |
| Components Requiring Fluid Check and Fill.....              | 219   |
| Components Requiring Lubrication.....                       | 218   |
| Lubrication and Maintenance Interval – Recommended          |       |
| Synchronized Intervals Table.....                           | 211   |
| Lubrication and Maintenance Interval Chart Notes.....       | 210   |
| Lubrication and Maintenance Interval Chart Symbols Key..... | 210   |
| Lubrication and Maintenance Intervals.....                  | 209   |
| Maintenance Intervals.....                                  | 209   |
| Lubrication Points.....                                     | 199   |
| Luggage Box Access.....                                     | 21    |
| Driver and Passenger Side.....                              | 21    |

|   |     |   |     |
|---|-----|---|-----|
| <b>M</b>  |     | <b>O (CONT.)</b>                                    |     |
| Main Features.....                                    | 95  | <i>Operating Instructions (cont.)</i>               |     |
| Maintenance Guidelines.....                           | 171 | Alternator.....                                     | 130 |
| Maintenance Intervals.....                            | 209 | Battery.....  | 130 |
| Lubrication and Maintenance Interval – Recommended    |     | BATTERY ON Indicator.....                           | 131 |
| Synchronized Intervals Table.....                     | 211 | Circuit Breakers, Fuses and Fusible Links.....      | 131 |
| Lubrication and Maintenance Interval Chart Notes..... | 210 | Electrical Load Control and Shedding (ELCS).....    | 132 |
| Lubrication and Maintenance Interval Chart Symbols    |     | Engine.....   | 132 |
| Key.....  | 210 | Air Compressor Cycling.....                         | 135 |
| Maintenance Record – Noise Control.....               | 5   | Certified Clean Idle.....                           | 134 |
| Manual Climate Controls.....                          | 100 | Charge Air Cooler.....                              | 132 |
| Manual Operation.....                                 | 91  | Electronic Engine Controller.....                   | 133 |
| Manual Transmissions.....                             | 142 | Engine Brake.....                                   | 133 |
| MaxxForce® 11, 13 and 15 Engine Brake With Eaton      |     | Engine Oil.....                                     | 136 |
| AutoShift®/UltraShift® Transmissions Special Driver   |     | Engine Performance Problems.....                    | 136 |
| Instructions.....                                     | 133 | MaxxForce® 11, 13 and 15 Engine Brake With Eaton    |     |
| MaxxForce® Engine Features.....                       | 134 | AutoShift®/UltraShift® Transmissions Special Driver |     |
| Mirror Controls.....                                  | 92  | Instructions.....                                   | 133 |
| <b>N</b>  |     | MaxxForce® Engine Features.....                     | 134 |
| No Restriction Reading Table.....                     | 191 | Self Diagnostics.....                               | 134 |
| Noise Emissions – Exterior.....                       | 196 | Exhaust Diesel Particulate Filter Regeneration..... | 139 |
| Air Intake System.....                                | 196 | Parked Regeneration Procedure.....                  | 141 |
| Body.....   | 196 | Regeneration Inhibit Switch.....                    | 141 |
| Engine Noise Shields/Blankets.....                    | 196 | Three-Position Regeneration Inhibit Switch.....     | 142 |
| Exhaust System.....                                   | 196 | Two-Position Regeneration Inhibit Switch.....       | 142 |
| Instructions for Proper Maintenance.....              | 196 | Fuel.....   | 137 |
| Normal Maintenance.....                               | 177 | Additional Unsafe Practices.....                    | 137 |
| <b>O</b>  |     | Fuel and Lubricant Additives.....                   | 137 |
| Operating Instructions.....                           | 128 | Fueling Precautions.....                            | 138 |
| Electrical.....                                       | 130 | Fueling Procedures.....                             | 137 |
|   |     | Hazards of Diesel Fuel/Gasoline Blends.....         | 137 |
|   |     | Reserve Fuel.....                                   | 138 |

## O (CONT.)

|  |     |
|--|-----|
| <i>Operating Instructions (cont.)</i>                                      |     |
| Ultra Low Sulfur Diesel Fuel Requirements.....                             | 137 |
| Unacceptable Fuel Blends.....  | 137 |
| Rear Axles.....  | 148 |
| Driver Controlled Differential Lock.....                                   | 150 |
| Locking or Limited Slip Differentials.....                                 | 148 |
| Tandem Axle Power Divider Lock (PDL) Control.....                          | 149 |
| Rear Suspension.....   | 150 |
| Air Suspension System Faults.....  | 151 |
| Rear Air Ride Suspension.....  | 150 |
| Rear Air Suspension Air Dump.....  | 150 |
| Steering.....  | 128 |
| Adjustable Steering Column.....  | 129 |
| Transmission.....  | 142 |
| Clutch Brake.....  | 148 |
| Clutch Precautions.....  | 145 |
| Double Clutch Procedures.....  | 145 |
| Eaton AutoShift® Transmissions (Optional).....                             | 146 |
| Eaton UltraShift® Transmissions (Optional).....                            | 148 |
| Engaging the Clutch.....   | 143 |
| Hydraulic Clutch Actuation System.....                                     | 144 |
| Manual Transmissions.....  | 142 |
| Power Take-off Control.....  | 148 |
| Operation.....   | 119 |
| Operation Safety.....  | 117 |
| Cab Controls.....  | 118 |
| Optional Diamond Logic® Electronic Application Solutions.....              | 8   |
| Optional Instrument panel gauge cluster Compass Calibration Procedure..... | 57  |
| Compass Declination Zone Set Procedure.....                                | 57  |
| Compass Directional Calibration Procedure.....                             | 60  |

## O (CONT.)

|  |    |
|--|----|
| Outside Temperature and Compass Displays (Optional)..... | 74 |
| Outside Temperature Reading.....                         | 74 |
| Overhead Console.....                                    | 45 |

## P

|   |     |
|---|-----|
| Panel Lighting.....                     | 75  |
| Park Lights.....                        | 75  |
| Parked Regeneration Procedure.....      | 141 |
| Parking Brake.....                      | 154 |
| Parking Brake Alarm.....                | 155 |
| Parking Brake Reset.....                | 155 |
| Parking Brake Alarm.....                | 155 |
| Parking Brake Indicator.....            | 157 |
| Parking Brake Reset.....                | 155 |
| Pedal Free Travel.....                  | 183 |
| Power Inverter.....                     | 115 |
| Power Operation.....                    | 92  |
| Power Receptacle.....                   | 101 |
| Power Sockets.....                      | 115 |
| Power Steering.....                     | 199 |
| Power Steering Systems.....             | 220 |
| Power Take-off Control.....             | 148 |
| Preface.....                            | 1   |
| Premium Display.....                    | 89  |
| Preparation.....                        | 24  |
| ProStar®+ Series Light Information..... | 231 |
| Purge Valve.....                        | 181 |

## Q

|  |    |
|--|----|
| Quadrant 1: Informational Displays.....    | 62 |
| Quadrant 2: Text and Warning Messages..... | 67 |



**Q (CONT.)**

Quadrant 3: Display Messages.....74  
 Quadrant 4: Transmission Gear Displays.....75

**R**

Radio Remote Control.....101  
 Raising the Hood.....18  
 Raising the Tilt-Away Bumper.....20  
 Reading Lights.....97  
 Rear Air Ride Suspension.....150  
 Rear Air Suspension Air Dump.....150  
 Rear Axle.....177  
     Inspection and Lubrication.....177  
 Rear Axle Unit Refill Capacities.....222  
 Rear Axles.....148  
     Driver Controlled Differential Lock.....150  
     Locking or Limited Slip Differentials.....148  
     Tandem Axle Power Divider Lock (PDL) Control.....149  
 Rear of Tractor.....37  
 Rear Suspension.....150, 198  
     Air Suspension System Faults.....151  
     Rear Air Ride Suspension.....150  
     Rear Air Suspension Air Dump.....150  
 Rear Wardrobe Cabinet.....113  
 Recirculation Filters.....175  
 Refrigerator Cabinet.....110  
 Regeneration.....196  
 Regeneration Inhibit Switch.....141  
 Remote Keyless Entry Operation (Optional).....90  
 Remote Power Inverter Panel.....101  
 Removal.....21  
 Removing Axle Shafts Before Towing.....164

**R (CONT.)**

Reporting Safety Defects.....5  
     Canadian Registered Vehicles.....5  
     U.S. Registered Vehicles.....5  
 Reserve Fuel.....138  
 Reservoir Moisture Draining.....153  
 Restraint Webbing System.....103  
 Right Engine Compartment.....32  
 Right Front of Tractor.....30  
 Right Rear of Tractor.....35  
 Right Side of Cab.....33  
 Right Side Under Vehicle.....34  
 Rotation.....203  
     Rotation Is Advisable.....203  
     Tire Replacement.....204  
 Rotation Is Advisable.....203

**S**

Safety Recalls and Authorized Field Changes.....5  
 Scheduled Maintenance.....187  
 Seat Belts.....118  
     Care of Seat Belts.....120  
     Operation.....119  
 Seats.....121  
 Self Diagnostics.....134  
 Service Information.....233  
 Side Access HVAC Filter.....174  
 Sleeper Control Panel.....98  
     Accent Light Dimmer Switch.....99  
     Accent Light Switch.....99  
     Electronic Climate Controller.....100  
     Engine Control Switch.....99

**S (CONT.)**

|   |          |
|---|----------|
| <i>Sleeper Control Panel (cont.)</i>                              |          |
| Manual Climate Controls.....                                      | 100      |
| Power Receptacle.....   | 101      |
| Radio Remote Control.....   | 101      |
| Remote Power Inverter Panel.....                                  | 101      |
| Sleeper Dome/Floor Light Switch.....                              | 99       |
| Sleeper Curtain.....  | 115      |
| Sleeper Dome/Floor Light Switch.....                              | 99       |
| Sleeper Fan.....  | 115      |
| Sleeper HVAC Filter.....  | 176      |
| SmartWave® Display.....   | 89       |
| SmartWave® Tire Pressure Monitoring System (TPMS).....            | 202      |
| Speakers.....   | 115      |
| Stability Control Systems – Bendix® RSP/WABCO RSC/Bendix ESP..... | 160      |
| Starting Procedures.....  | 123      |
| After the Engine Starts.....                                      | 124      |
| Cold Weather.....   | 125      |
| Cold Weather Operation.....                                       | 126      |
| Cold Weather Starting.....  | 125      |
| Engine Idle Shutdown Timer (Optional).....                        | 127      |
| Engine Idling.....  | 126      |
| Winter Front Usage.....   | 127      |
| Emergency Starting.....   | 124      |
| Engine Shutdown.....  | 124      |
| Engine Starting.....  | 123      |
| Hot Weather Operation.....  | 127      |
| Steering.....   | 128, 198 |
| Adjustable Steering Column.....                                   | 129      |
| Lubrication Points.....   | 199      |
| Power Steering.....   | 199      |

**S (CONT.)**

|   |        |
|---|--------|
| <i>Steering (cont.)</i>                                 |        |
| Tightening Steering Intermediate Shaft Joint Bolts..... | 198    |
| Steering Column and Switches.....                       | 78     |
| Steering Wheel Controls.....                            | 77     |
| Cruise Control.....                                     | 78     |
| Storage Duration - One Month or Less.....               | 2      |
| Storage Duration - Over One Month.....                  | 3      |
| Storage Facilities.....                                 | 4      |
| Supporting Your Vehicle for Service.....                | 173    |
| Suspension (Air and Steel Springs).....                 | 197    |
| Front Suspension.....                                   | 197    |
| Rear Suspension.....                                    | 198    |
| Switches.....   | 75, 82 |
| Courtesy Lights.....                                    | 76     |
| Daytime Running Lights (DRL).....                       | 75     |
| Dome Lighting.....                                      | 76     |
| Headlights.....   | 75     |
| Lights On With Wipers.....                              | 75     |
| Panel Lighting.....                                     | 75     |
| Park Lights.....  | 75     |
| System Description.....                                 | 93     |

**T**

|   |     |
|---|-----|
| Tampering with Noise Control System Prohibited.....     | 4   |
| Tandem Axle Power Divider Lock (PDL) Control.....       | 149 |
| Television Mount.....                                   | 115 |
| Terminal Inspection-Cleaning-Corrosion Protection.....  | 185 |
| Three-Position Regeneration Inhibit Switch.....         | 142 |
| Tightening Steering Intermediate Shaft Joint Bolts..... | 198 |
| Tilt-Away Bumper.....                                   | 19  |
| Lowering the Tilt-Away Bumper.....                      | 20  |

**T (CONT.)**

|  |     |
|--|-----|
| <i>Tilt-Away Bumper (cont.)</i>                        |     |
| Raising the Tilt-Away Bumper.....                      | 20  |
| Tire Maintenance.....                                  | 201 |
| Checking Inflation.....                                | 201 |
| Underinflation.....                                    | 201 |
| Tire Replacement.....                                  | 204 |
| Tire Warnings.....                                     | 199 |
| Tires.....   | 199 |
| Dual Tires Matching.....                               | 203 |
| Dual Tires Mixing.....                                 | 203 |
| Inspection.....  | 202 |
| Loads.....   | 203 |
| Rotation.....  | 203 |
| Rotation Is Advisable.....                             | 203 |
| Tire Replacement.....                                  | 204 |
| SmartWave® Tire Pressure Monitoring System (TPMS)..... | 202 |
| Tire Maintenance.....                                  | 201 |
| Checking Inflation.....                                | 201 |
| Underinflation.....                                    | 201 |
| Tire Warnings.....                                     | 199 |
| Use of Tire Chains.....                                | 205 |
| Wear.....  | 204 |
| Irregular Wear.....                                    | 205 |
| Wheel and Tire Balancing.....                          | 204 |
| Torque Specifications.....                             | 227 |
| Disc Wheel Nut Torque Chart.....                       | 228 |
| U-Bolt Nut Torque Chart.....                           | 227 |
| Tow Hooks.....   | 163 |
| Tower Wardrobe Cabinet.....                            | 112 |
| Towing Instructions.....                               | 162 |
| Tow Hooks.....   | 163 |

**T (CONT.)**

|   |     |
|---|-----|
| <i>Towing Instructions (cont.)</i>  |     |
| Towing Vehicle With Front Wheels Suspended.....                             | 164 |
| Towing Vehicle With Rear Wheels Suspended.....                              | 165 |
| Towing Vehicles With Driver Controlled Differential Lock.....               | 164 |
| Installing Axle Shafts.....   | 165 |
| Removing Axle Shafts Before Towing.....                                     | 164 |
| Towing Vehicle With Front Wheels Suspended.....                             | 164 |
| Towing Vehicle With Rear Wheels Suspended.....                              | 165 |
| Towing Vehicles With Driver Controlled Differential Lock.....               | 164 |
| Installing Axle Shafts.....   | 165 |
| Removing Axle Shafts Before Towing.....                                     | 164 |
| Tractor Inspection.....   | 24  |
| Cab Interior Inspection.....  | 41  |
| Exterior Lights Check.....  | 24  |
| Fifth Wheel and Coupling Area.....  | 40  |
| Front of Tractor.....   | 29  |
| Left Engine Compartment.....  | 26  |
| Left Front of Tractor.....  | 27  |
| Left Rear of Tractor.....   | 38  |
| Left Side Cab Area.....   | 25  |
| Preparation.....  | 24  |
| Rear of Tractor.....  | 37  |
| Right Engine Compartment.....   | 32  |
| Right Front of Tractor.....   | 30  |
| Right Rear of Tractor.....  | 35  |
| Right Side of Cab.....  | 33  |
| Right Side Under Vehicle.....   | 34  |
| Tractor-Trailer Connections.....  | 166 |
| Connecting/Disconnecting a Trailer to a Vehicle with Air<br>Suspension..... | 166 |
| Fifth Wheel Operation.....  | 166 |

## **T** (CONT.)

|  |          |
|--|----------|
| <i>Tractor-Trailer Connections (cont.)</i>                 |          |
| Fifth Wheel Jaw Monitoring.....                            | 169      |
| Fifth Wheel Jaw Unlock Control.....                        | 168      |
| Fifth Wheel Slide Switch (Optional).....                   | 167      |
| Hook-Up.....   | 167      |
| Un-Hook.....   | 168      |
| Trailer Air Supply and Parking Brake Modular Controls..... | 156      |
| Trailer Brake Hand Control.....                            | 155      |
| Transmission.....  | 142, 208 |
| Clutch Brake.....  | 148      |
| Clutch Precautions.....                                    | 145      |
| Double Clutch Procedures.....                              | 145      |
| Eaton AutoShift® Transmissions (Optional).....             | 146      |
| Eaton UltraShift® Transmissions (Optional).....            | 148      |
| Engaging the Clutch.....                                   | 143      |
| Hydraulic Clutch Actuation System.....                     | 144      |
| Manual Transmissions.....                                  | 142      |
| Power Take-off Control.....                                | 148      |
| Troubleshooting.....                                       | 191      |
| High Restriction Reading Table.....                        | 191      |
| No Restriction Reading Table.....                          | 191      |
| Two-Position Regeneration Inhibit Switch.....              | 142      |
| Typical Interior Fuse Panel Layout.....                    | 229      |
| Typical Luggage Compartment Fuse Panel Layout.....         | 230      |

## **U**

|  |     |
|--|-----|
| U-Bolt Nut Torque Chart.....                   | 227 |
| U.S. Registered Vehicles.....                  | 5   |
| Ultra Low Sulfur Diesel Fuel Requirements..... | 137 |
| Un-Hook.....                                   | 168 |
| Unacceptable Fuel Blends.....                  | 137 |

## **U** (CONT.)

|                                       |     |
|---------------------------------------|-----|
| Underinflation.....                   | 201 |
| Unit Refill Capacities.....           | 220 |
| Cooling System Refill Capacities..... | 220 |
| Crankcase and Oil Filters.....        | 220 |
| Hydraulic Clutch System.....          | 220 |
| Power Steering Systems.....           | 220 |
| Rear Axle Unit Refill Capacities..... | 222 |
| Unlocking the Door.....               | 91  |
| Upholstery Care.....                  | 182 |
| Upper Bunk.....                       | 106 |
| Entering The Upper Bunk.....          | 107 |
| Exiting The Upper Bunk.....           | 108 |
| Use of Tire Chains.....               | 205 |

## **V**

|   |    |
|---|----|
| Vehicle Identification.....               | 12 |
| Engine Serial Number.....                 | 13 |
| Feature Codes.....                        | 12 |
| Line Set Ticket.....                      | 13 |
| Vehicle Identification Number (VIN).....  | 12 |
| Vehicle Identification Number (VIN).....  | 12 |
| Vehicle Storage Instructions.....         | 2  |
| Storage Duration - One Month or Less..... | 2  |
| Storage Duration - Over One Month.....    | 3  |
| Storage Facilities.....                   | 4  |
| Vent Window.....                          | 92 |

## **W**

|                         |     |
|-------------------------|-----|
| Warning Indicators..... | 48  |
| Warning Messages.....   | 74  |
| Washing and Waxing..... | 182 |

---

**W (CONT.)**

|   |     |
|---|-----|
| Wear.....   | 204 |
| Irregular Wear.....                                   | 205 |
| Wheel and Tire Balancing.....                         | 204 |
| Wheel and Wheel Nut Maintenance and Installation..... | 205 |
| Hub-Piloted Wheel Installation Procedures.....        | 206 |
| Wheel Nut Torque Maintenance.....                     | 206 |
| Wheel Nut Torque Maintenance.....                     | 206 |
| Wheels.....   | 205 |

**W (CONT.)**

|   |     |
|---|-----|
| <i>Wheels (cont.)</i>                                 |     |
| Transmission.....                                     | 208 |
| Wheel and Wheel Nut Maintenance and Installation..... | 205 |
| Hub-Piloted Wheel Installation Procedures.....        | 206 |
| Wheel Nut Torque Maintenance.....                     | 206 |
| Window Lockout Function.....                          | 92  |
| Windows.....  | 102 |
| Winter Front Usage.....                               | 127 |



**CALIFORNIA**

**Proposition 65 Warning**

**Diesel engine exhaust and some of its constituents are known to the State of California to cause cancer, birth defects and other reproductive harm.**