

# Driver's Handbook

FM, FH

This is a complete Driver's Handbook with all the information that can exist in our chassis unique handbooks.

The information in the chassis unique handbooks is steered on variants and its content varies. This can cause duplicated information in this complete handbook, which can make it difficult to read correctly. It is only intended for internal use.

From build week 937 each truck has its unique handbook which is possible to order at [pubstore@elanders.com](mailto:pubstore@elanders.com).

**VOLVO**

---

DEAR VOLVO OWNER

THANK YOU FOR CHOOSING VOLVO.

This vehicle binder describes the driving and care of your truck and instructions for the tachograph. It also contains documents such as the Warranty book, Volvo Action Service card and Driver service documents.

In order for your truck to retain its high safety, reliability and long life, we recommend that you heed our advice regarding the driving and care of your vehicle.

If there is anything else you wonder about concerning service, maintenance, oils or the care of your truck or you are missing some documentation in the binder, please contact your dealer.

Additional useful information about your truck and its functions can be found online:  
<http://www.volvo.com>

The specifications and illustrations in this binder are not binding and we reserve the right to change them without prior information.

Volvo Lastvagnar AB  
GÖTEBORG

©1998 Volvo Trucks AB, Gothenburg.

Reproduction of the contents of this vehicle binder, wholly or in part, is prohibited by law without written permission from Volvo Trucks AB.

The prohibition covers all forms of reproduction, through printing, copying, recording on tape, etc.

---

The following levels of notification and warning are used in this binder.

Note!	Indicates a situation, use or circumstance that should be emphasised.
Important!	Indicates a situation, use or circumstance that is important to be aware of to avoid personal injury or damage to the product.
Caution!	Indicates a potentially dangerous situation that, unless avoided, may lead to minor or moderate personal injury or damage to the product.
Warning!	Indicates a potentially dangerous situation that, unless avoided, <b>may</b> lead to death, serious personal injury or damage to the product.
Danger!	Indicates a potentially dangerous situation that, unless avoided, <b>will</b> lead to death or serious personal injury.

**VOLVO**

Volvo Lastvagnar AB  
GÖTEBORG

---

## Symbols

The following symbols may be found on your truck.

The meaning of the symbols is as follows:



Use protective goggles



Read information in the driver's binder



Keep out of reach of children



Corrosive



Avoid sparks or naked flame



Explosive

# Table of Contents

---

<b>Introduction.....</b>	<b>1</b>	Alarm, warning and information symbols.....	36
LVD system.....	1	Status symbols.....	40
EBS.....	1	Other Symbols.....	41
Air suspension.....	1	Menu structure.....	42
Booster.....	2	Show menus.....	45
Dynafleet.....	2	Step between the menus.....	45
<b>Running in.....</b>	<b>4</b>	Change a setting.....	45
<b>Starting and stopping.....</b>	<b>5</b>	Temperature, outside.....	47
Starting instructions.....	5	Temperature, engine oil.....	47
Starting instructions.....	5	Temperature, gearbox.....	47
Start the truck.....	5	Voltmeter/Ammeter.....	47
Stopping the truck.....	6	Gear position.....	48
Stopping the truck.....	6	Pressure, primary tank.....	48
Stopping the truck.....	6	Fuel consumption.....	48
Parking.....	7	Leg data.....	49
Clutch.....	7	Remaining fuel.....	49
Keys.....	7	AdBlue.....	49
Start the engine.....	8	Trip meter.....	50
Warming up.....	11	Average speed.....	50
Change idling speed.....	11	Estimated time of arrival.....	51
Fuel heater.....	12	Time and Date.....	51
<b>Instruments and controls.....</b>	<b>13</b>	Alarm clock.....	52
Overview.....	13	Driving/rest time.....	53
Gauges.....	17	Black Panel.....	53
Symbols.....	19	Backlight.....	53
Lighting and headlamps.....	22	Favourite Display, setting.....	54
Windscreen wipers.....	25	Night/Day.....	56
Rain sensor.....	25	Vehicle Messages.....	56
Parking brake.....	26	Tyre pressure.....	56
Trailer brake.....	29	Set wheel ID.....	57
Electric trailer brake.....	29	Set reference pressure.....	57
Air suspension.....	30	Reset.....	58
<b>Information display.....</b>	<b>33</b>	ATS.....	58
General, about the display.....	33	Start regeneration.....	58
The first that is shown.....	34	Abort regeneration.....	59
General, about messages.....	34	Activate/Deactivate ATS.....	59
Information messages.....	35	System conditions.....	59
Warning messages.....	35	Soot/ash level.....	60
Stop message.....	36	Programming, p-heater timer.....	60
		Reset, p-heater timer.....	61
		Language.....	61
		Units.....	61

# Table of Contents

---

Time/Date.....	62	Fuel consumption.....	90
Display lighting.....	63	Leg data.....	90
Change password.....	63	Remaining fuel.....	91
Traction control.....	64	AdBlue.....	91
DAS.....	64	Trip meter.....	91
LCS.....	64	Average speed.....	92
Fleet limits.....	64	Driving/rest time.....	92
Ammeter sensor calibration.....	66	Time and Date.....	92
Fleet ID.....	66	Menu structure.....	93
Trailer detection.....	67	Black Panel.....	93
Day running lights automatic.....	68	Night/Day.....	94
Draining/priming.....	68	Backlight.....	94
Fault diagnostics.....	69	Contrast.....	94
Instrument panel cluster self test.....	70	Language.....	94
Part number.....	71	Units.....	95
Vehicle data.....	72	Time/Date.....	95
Vehicle ID.....	72	Program.....	96
Total value.....	73	Reset.....	96
Trip data.....	73	Traction Control.....	97
Reset trip data.....	74	Day Running Light.....	97
Password.....	74	Draining/priming.....	97
Service reminder.....	75	Fault diagnostics.....	97
Estimated lining wear.....	77	Part number.....	99
Monitoring of the wheel brakes.....	78	Calibration ID.....	99
High brake temperature warning.....	78	Service reminder.....	99
Resetting fault codes.....	78	Numeric language, general.....	102
Position and content.....	80	Display control stalk.....	102
Display.....	81	Text strings.....	103
Display control stalk.....	82	Stop message.....	103
General, about messages.....	82	Change language.....	104
Information messages.....	82	Menus, general.....	104
Warning messages.....	83	Password-protected menus.....	104
Stop message.....	83	Menus available when driving.....	104
Acknowledge messages.....	83	Menus with stationary vehicle.....	108
Alarm, warning and information symbols.....	84	Numerical translation table.....	116
Status symbols.....	88	<b>Driving.....</b>	<b>127</b>
Other Symbols.....	89	Driving hints.....	127
Gear position.....	89	Hill start aid.....	130
Temperature, outside.....	89	Reversing camera.....	131
Engine oil pressure.....	89	Reversing Warner.....	133
Temperature, engine oil.....	89	Traction Control System (TCS).....	133
Voltmeter/Ammeter.....	90	Front wheel drive.....	135

# Table of Contents

---

Differential lock.....	136	When the vehicle must be braked manually.....	202
Differential lock.....	140	Brake protection.....	202
Differential locks.....	143	Driving at low speed.....	203
Automatic engagement of the differential lock (DLC – Diff Lock Control).....	146	If the ACC does not work.....	204
Auxiliary brakes.....	148	<b>Powertronic.....</b>	<b>205</b>
Brake Blending.....	152	Powertronic, general.....	205
ABS.....	152	Gear shifter.....	205
ESP — Electronic Stability Program.....	153	Buttons.....	206
Control of engine torque.....	153	Display.....	207
Brake lining wear equalisation.....	154	Driving programs.....	209
Panic braking function.....	154	Automatic gear changing.....	209
Manual gearbox.....	154	Kickdown.....	210
Hydraulic bogie lift.....	158	Manual gear changing.....	210
Bogie.....	159	Select starting gear.....	210
Tridem.....	165	Autoneutral.....	211
Steered rear axle.....	168	Brake interlock.....	211
Cruise control.....	169	Dual driver stations.....	212
Constant engine speed control.....	170	Auxiliary brakes.....	212
Lane Keeping Support.....	170	Actions with gearbox malfunction.....	212
Lane Change Support.....	172	Reversing with loads.....	212
Driver Alert Support.....	174	Rocking free.....	213
Power take-off.....	176	Marshalling.....	213
High range lock-up.....	179	Idling speed.....	213
High range lock-up.....	181	Oil temperature.....	214
Tying down the truck on a ferry.....	182	Retarder temperature.....	214
Ride height memory.....	187	Oil pressure.....	215
<b>ADR.....</b>	<b>193</b>	Oil filter.....	215
General.....	193	Checking the oil level.....	215
Turn off the power.....	193	<b>I-Shift.....</b>	<b>217</b>
Turn on the main switch.....	194	I-shift, general.....	217
Turn on power for 20 minutes.....	195	Gear selector.....	217
<b>Adaptive cruise control.....</b>	<b>197</b>	Buttons.....	219
General.....	197	Display.....	220
Engaging ACC.....	198	Program packages.....	222
Disengage ACC.....	199	Automatic shifting.....	225
Inactivate ACC.....	199	Manual shifting.....	228
Change speed.....	199	Reverse gears.....	229
Change the time gap.....	200	In case of gearbox malfunction.....	230
When the truck itself adjusts the speed....	201	Starting on hills.....	230
		Driving off road.....	231

# Table of Contents

---

Clutch.....	231	<b>Exhaust cleaning.....</b>	<b>291</b>
<b>I-Shift.....</b>	<b>232</b>	General.....	291
I-Shift, general.....	232	Driving a truck with a Euro 4 or	
Program packages.....	232	Euro 5 engine.....	294
Function description.....	234	Filling with AdBlue.....	297
Gear shifter.....	236	Cleaning the AdBlue tank.....	299
Buttons.....	238	Diesel particulate filter.....	299
Display.....	239	<b>Cab.....</b>	<b>303</b>
Automatic gear change.....	241	Air suspension equipment.....	303
Manual gear changing.....	246	Seats.....	309
Reverse gears.....	247	Adjusting the steering wheel.....	313
Actions with gearbox malfunction.....	248	Doors.....	314
Fuel economy driving.....	248	Central locking.....	316
Hill start.....	250	Main switch.....	318
Driving on poor roads and in		Air conditioning ECC (Electronic	
difficult conditions.....	251	Climate Control).....	318
Disengaging.....	251	Air conditioning MCC (Manual	
Starting when stuck.....	251	Climate Control).....	323
Full VEB/VEB+ in manual mode.....	253	Climate control system HEAT.....	326
Extra down-changing for		Cab heater PH-CAB.....	328
maximum engine brake in low gears.....	253	Cab and engine heater PH-ENGCA.....	333
Changing driving direction.....	253	Rest heater SS-HEAT.....	341
Driving with the gearbox-mounted		Luggage compartment hatch.....	343
power take-off engaged.....	253	Electrically operated sun roof.....	344
Rocking to empty the platform.....	254	Lighting.....	344
Driving on rollers.....	254	Electrical power outlet.....	351
<b>Loading and unloading.....</b>	<b>255</b>	Bunk bed.....	351
General.....	255	Lower bunk.....	352
Ride height control.....	255	Smoke detector.....	353
Loading and unloading height memory... ..	258	Tilt the cab.....	354
Quick unloading.....	265	Mobile telephone, communication	
Using the air suspension with the		equipment.....	359
ignition turned off.....	267	Alarm on.....	359
Loading and unloading with the		Alarm without motion detectors.....	360
main switch off.....	270	Alarm off.....	361
Fetch the swap body.....	276	Starting the assault alarm.....	361
Leave the swap body.....	281	Switching off the assault alarm.....	362
Fetch a container.....	284	Go into service mode.....	362
Deliver a container.....	286	To get out of service mode.....	363
Load indicator.....	287	Assistance button.....	363



# Table of Contents

---

<b>Refrigerator.....</b>	<b>364</b>	Introduction.....	386
Safety instructions.....	364	General Overview.....	387
General.....	364	Main Functions.....	395
Usage.....	364	Tips and Tricks.....	405
Starting the refrigerator.....	365	Main Functions.....	405
Turning off the refrigerator.....	365	Tips and tricks.....	428
Voltage protector.....	365	<b>Telephone.....</b>	<b>430</b>
Tilting the cab.....	366	Getting started.....	430
Cleaning.....	366	Calling.....	432
Defrosting.....	366	While making a call.....	435
Interior lighting.....	366	Managing messages.....	436
Fault tracing.....	367	Menus.....	438
Tips on saving energy.....	367	Measures with malfunctions.....	443
Technical specifications.....	367	<b>Booster.....</b>	<b>444</b>
<b>Fridge.....</b>	<b>368</b>	Booster.....	444
Safety instructions.....	368	Installation.....	444
General.....	368	Methods of use.....	444
Usage.....	368	Fuses.....	444
Starting the refrigerator box.....	369	Indicator lamps.....	444
Switching off the refrigerator box.....	369	Subwoofer controls and switch.....	445
Voltage protector.....	369	Fault tracing.....	445
Tilting the cab.....	370	<b>Dynafleet.....</b>	<b>447</b>
Cleaning.....	370	Dynafleet.....	447
Defrosting.....	370	Technical description.....	448
Fault tracing.....	370	Controls.....	450
Tips on saving energy.....	371	Display.....	452
Technical specifications.....	372	Menus and symbols.....	453
<b>Alcolock.....</b>	<b>373</b>	Using the menus.....	454
Start up.....	373	Starting the system.....	455
Restarting the vehicle.....	375	Shutting off the system — stand by.....	456
Sharing a vehicle.....	376	Transferring data.....	456
Energy conservation.....	380	General.....	457
Volume control.....	381	Mail.....	457
Language selection.....	382	Mail menu.....	458
Dates.....	383	General driving and resting times.....	459
General messages and errors.....	383	Orders.....	461
Technical messages and errors.....	384	Logs.....	462
<b>Radio/CD.....</b>	<b>386</b>	Driver coaching.....	464
Safe Operation of the Radio.....	386	Emergency & Assistance.....	465
		Tachograph download menu.....	465

# Table of Contents

---

Settings.....	467	General information about oils and greases.....	523
System errors and warnings.....	468	Engine.....	525
<b>External equipment.....</b>	<b>470</b>	Fuel system.....	530
Roof air deflector, setting instructions.....	470	Diesel fuel— quality and function.....	531
Short low cab FH.....	472	Changing fuel filter.....	536
Long low cab FH.....	473	Filter for fuel tank ventilation.....	537
Globetrotter FH.....	474	Priming the fuel system.....	537
Roof air deflector, setting instructions.....	476	Draining the fuel tank.....	538
Globetrotter XL FH.....	478	Changing filter.....	539
Roof air deflector, setting instructions.....	483	Drain the cooling system.....	542
Short low cab FM.....	485	Service intervals.....	544
Long low cab FM.....	486	Anti-freeze.....	544
Globetrotter FM.....	487	Fill with coolant in an empty system.....	545
Globetrotter LXL FM.....	488	Viscous fan.....	545
Front mirror.....	490	Electrically controlled fan.....	545
Ladder.....	491	Check the drive belts (Multi-V).....	546
Side underrun guard.....	492	Working on the electrical system.....	546
Lower the spare wheel.....	494	Instructions for electrical welding.....	547
Raise the spare wheel.....	495	Connection of electrical accessories.....	548
Spare wheel retainer behind the cab.....	496	Checking electrolyte level in batteries.....	549
Turntable, general advice.....	499	Charge status.....	550
Couple the trailer.....	500	Specifications for the electrical system.....	551
Moving the turntable.....	502	Manual gearbox and I-shift.....	552
<b>Maintenance.....</b>	<b>504</b>	Automatic gearbox.....	559
General information.....	504	Transfer gearbox.....	562
Checks before driving.....	504	Driving front axle.....	566
Checks when fuelling.....	508	Flywheel mounted power take-off.....	570
Changing wiper blades.....	509	Compact retarder.....	571
Replace the battery in the remote control.....	510	Air drier, general.....	575
Changing bulbs.....	510	Checking the air drier.....	576
Engine wash.....	516	Charging with air from an external compressed air source.....	577
Washing the chassis.....	516	Brake lining.....	577
Wash the cab.....	516	Servo steering.....	578
Polishing and waxing.....	517	Hydraulic pusher axle and trailing wheel axle.....	579
Care of upholstery.....	518	Rear axle.....	580
Paintwork damage.....	519	Rear axle with hub reduction.....	587
Care of aluminium rims.....	521	Tyres.....	588
Care of steel rims.....	521	Changing wheels.....	593
Tools.....	522	Disc wheel for disc brakes.....	600
		Painting rims.....	601

# Table of Contents

---

Spare wheel in Combi-box.....	602
Snow chains.....	602
Hydraulic bogie lift.....	603
Bodywork.....	603
Cab tilt pump.....	604
Central lubrication.....	604
Changing air filter for air conditioning system.....	605
Refrigerant.....	606
Parking heater.....	606
Chassis lubrication.....	607
Type plates, location.....	615
<b>Fuses and relays.....</b>	<b>617</b>
General.....	617
Electrical distribution unit, left- hand drive trucks.....	618
Electrical distribution unit, right- hand drive trucks.....	619
Main fuses.....	620
In relay and fuse box.....	622
To superstructure.....	626
<b>If something happens.....</b>	<b>628</b>
Air suspension in locked mode.....	628
Airbag.....	630
Warning signs and first-aid.....	631
Fire extinguisher.....	631
Starting with starting cables.....	632
Towing.....	635
Back-up function.....	641
In case of gearbox malfunction.....	641
If the vehicle gets stuck.....	642

## LVD system

The vehicle is equipped with software that registers different types of information about the vehicle. The information will be transferred to Volvo Trucks AB and used in product development and fault tracing in engines and vehicles. Information that is saved concerns, among other things, speed, fuel consumption and torque. Volvo Trucks AB and its authorised workshops will make use of this information. Questions concerning the use of this information can be made to Volvo Action Service..

## EBS

EBS generation 3 functions in a different way to earlier braking systems. In previous braking systems a particular pressure to the pedal gave a particular pressure to the braking system. With EBS 3 a particular pressure on the pedal will give a particular reduction of speed. The same depression of the pedal gives the same reduction of speed, but the pressure to the brake cylinders on the axles varies with the axle load.

After changing loads, the first brake application can feel strange, since the system must learn the new axle loads.

EBS adapts the braking pressure to the trailer so that the trailer brakes to the same degree as the truck.

## Air suspension

This truck has full air suspension and thus has bellows instead of leaf springs. The amount of air in the bellows can be regulated, and determines the ride height.

The air suspension is electronically controlled (ECS, electronically controlled suspension) and maintains constant ride height irrespective of load

## 2 Introduction

---

weight and positioning. Ride height can also be controlled manually, by using the control box.

In order for the air suspension to work, the pressure in the air tanks must be greater than 8 bar. The air suspension is activated after starting or when the parking brake is released or when the air suspension control box is used. None of the suspension functions will work before the system has been started by one of these methods.

This truck has rear air suspension and thus has bellows instead of rear leaf springs. The amount of air in the bellows can be regulated, and determines the ride height.

The air suspension is electronically controlled (ECS, electronically controlled suspension) and maintains constant ride height irrespective of load weight and positioning. Ride height can also be controlled manually, by using the control box.

In order for the air suspension to work, the pressure in the air tanks must be greater than 8 bar. The air suspension is activated after starting or when the parking brake is released or when the air suspension control box is used. None of the suspension functions will work before the system has been started by one of these methods.

### Booster

Volvo's multi-channel booster VA 400.8 is a premium-class eight-channel power amplifier for motor vehicles. It has integrated cross-overs for all channels and a number of sub-woofer controls for individual adjustments. The booster is factory installed and preset to give a natural and well balanced sound.

### Dynafleet

Dynafleet is a system for transport planning combined with vehicle planning, message handling and automatic reporting of vehicle status and driver times.

The driver communicates continually with the office. The traffic officer in the office can direct the vehicle to various places for various missions. The driver can send messages to other drivers, to the office or privately. Contact between the driver and the office means that much of the order administration can be administered in a simple way and more effective manning of transport is achieved. Communication with the central office takes place via the GSM mobile phone network.

The system collects information from the tachograph and the engine control unit. Dynafleet provides the driver with information about the vehicle and driving activities. This makes it possible to have a better transport administration and follow-up of the running costs of the vehicle, the work contribution of the driver and how economically the driver drives.

The section “Design and function” describes the most basic functions that all drivers must be familiar with. In the “System management” section there is a system overview and a description of how the system is started. The remaining sections describe the system functions in more detail.

## 4 Running in

---

Drive carefully during the truck's first 5 000 km. Keep the engine speed within the green area on the tachometer.

Do not drive fast with a heavy load. Keep an eye on the warning lamps!

REMEMBER to leave the truck for warranty service after 4 weeks operation or 10 000 km mileage, depending on which occurs first. (With vehicles manufactured in Europe the guaranteed service is only offered if they have automatic transmission, fly-wheel mounted power take-off or all-wheel drive)

All Volvo engines are test driven before delivery. This means that we have control of all fits and decline all responsibility for any damage caused by careless driving.

### **Note!**

During the first 1 500 km, the truck's power train shall **not** be subject to heavy loads, since this can cause abnormally high temperatures in gears and drives.

## Starting instructions

Put the gear selector in the neutral or tilted position or the engine will not start.

When the air pressure to the gearbox is too low, a warning will be displayed automatically. An icon will appear on the display at the same time as the information lamp comes on. Wait until the lamp has gone out before driving off.



Information lamp



Symbol for low air pressure to gearbox

## Starting instructions

Put the gear shift lever in the neutral or tilted position, otherwise the engine will not start.

If the air pressure to the gearbox is too low, a warning will be shown automatically in the display. An icon will appear in the display at the same time as the information lamp lights. Wait until the lamp has gone out before driving off. Then move the gear shift lever to A, M or R to be able to drive.



J3014466

Information lamp



J3008849

Icon for low air pressure to gearbox

## Start the truck

To start the truck, select neutral position N and turn the key. The truck cannot be started if the gear shift lever is in the A, M or R position.



## Stopping the truck

When the vehicle is stationary:

- Apply the parking brake.
- Move the gear selector to N, neutral.
- Switch off the engine.



### Caution!

Always apply the parking brake and put the gear selector in N when the vehicle is parked or whenever the driver leaves the driver position.

## Stopping the truck

When the vehicle is stationary:

- Apply the parking brake.
- Move the gear shift lever to N, neutral.
- Switch off the engine.



### Caution!

Always apply the parking brake and move the gear shift lever to N when the truck is parked or if the driver must leave the cab for some reason.

## Stopping the truck

When the vehicle is stationary:

- Apply the parking brake.
- Move the gear shift lever to N, neutral.
- Switch off the engine.



### Caution!

Always apply the parking brake and move the gear shift lever to N when the truck is parked or if the driver must leave the cab for some reason.

## Parking

Since the gearbox does not have a “parking position” the truck's **parking brake must always be used** when the driver has parked the vehicle and left the cab. For longer stops and when the driver leaves the driver's seat, the gear shift lever must also be moved to position N.

## Clutch

The clutch is of the dry disc type, i.e. no torque converter. Therefore, never pull away in high gears by slipping the clutch. If the clutch overheats, the information lamp will light and a symbol will appear in the display.

If the information lamp lights when the vehicle is started and the truck is already moving, continue to drive.

If the information lamp lights when the vehicle is started and the truck is stationary, move the gear shift lever to the A or R position and let the engine run at idle until the light goes out.

When starting in manual mode, choose 1st gear to avoid straining the clutch.



J3014466



J3008835

### **Caution!**

Never hold the vehicle stationary on an uphill slope by using the accelerator pedal. The clutch could overheat, which could cause it to fail.

## Keys

All keys have the same number as on the separate number tag. Remove the number tag from the key ring, to ensure that no unauthorized person can see the tag. Put or tape the tag in a safe place (there is self adhesive tape on the back).

### **Note!**

Do not have other keys on the same key-ring as the ignition key. The ignition key contain electronics which can be affected.

# 8 Starting and stopping

---



J3014615

Number tag. Remove the number tag from the key-ring and store it in a safe place.

## Start the engine

- 1 Switch on the main switch.
- 2 Check that
  - the parking brake is applied
  - the gear lever is in neutral.
  - auxiliary brakes are in position 0
- 3 Turn the starter key to drive position

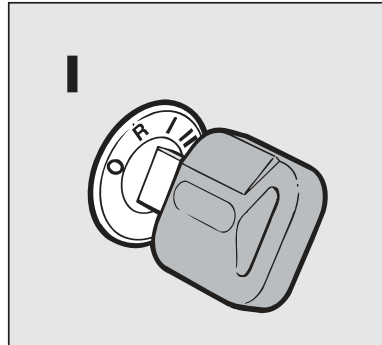

J7008414

## Note!

If the key is turned directly from off position to start position, there will be a delay of about 1 second before the starter motor is activated. During this time the starter motor shows no response as it is activated via EMS. When starting from radio position there is however no such delay.

## Note!

If the key is turned directly from the off to the starting position, it is not certain that the automatic radio code entry will function. To avoid this problem, wait a short while in the drive position before starting.

**4** The display will show the oil level in the engine. If the engine has been running during the previous 20 minutes nothing will be shown. The value shown under the graph is the difference between the engine max and min oil volumes.

**5** If the truck has air bags, the symbol for this is shown on the display



J3008842

**6** Check that all the instrument panel lamps are working

## 10 Starting and stopping

7 If the engine has air intake heating, turn the key to the air intake heating position and release the key

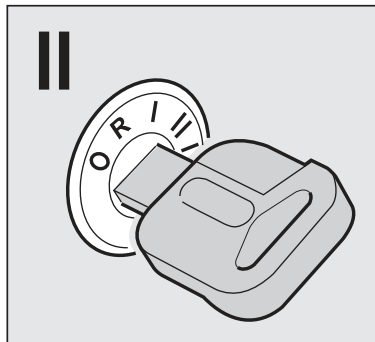

J3015694

8 Wait until the pre-heating symbol goes out



J0008226

9 Start the engine

Run the starter motor by turning the key to the start position. If the engine does not start, the starting attempt will be automatically shut off after 15 seconds. A new attempt can be made if the key is first turned back to 0 position and then to the start position.

If the overheating protection is triggered, a message is shown on the display when the overheating protection is activated. The message shows how long the starter motor must be allowed to cool before it will be possible to try to start the truck again, usually 10–15 minutes.

Preheating symbol

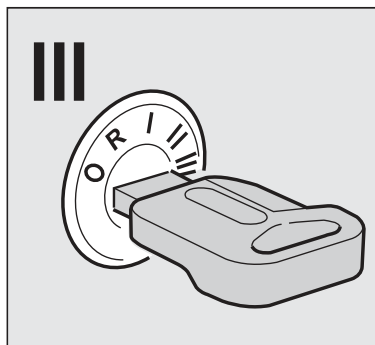

J3015695



**Warning!**

Do not use start gas. An explosion can cause considerable damage.

10 Hold down the brake pedal for a few seconds to enable the cruise control. The air suspension is

activated first after the parking brake is released or if the air suspension control box is used.

If the temperature of the coolant is below 50°C when the engine is started the engine speed will be limited to 1000 rpm for 15 seconds

## Warming up

Warm the engine up by driving with low engine speed rather than running the engine while stationary. Avoid revving up excessively and high engine speed.

After starting let the clutch out in order to warm up the gearbox. The oil pump in the gearbox will begin working and will quickly attain working temperature.

### Note!

It is especially important that the gearbox should be warmed up if the outside temperature is below 0°C.

## Change idling speed

The preset idle speed can be altered between 550 rpm and 650 rpm. When the truck is delivered, the idle speed is normally 600 rpm. (To change the idle speed temporarily, i.e. when the PTO is in use, see section "Constant engine speed control")

Conditions:

- The temperature of the coolant should exceed 50°C.
- The truck should remain stationary with the engine idling (the accelerator must not be depressed) when the adjustment is begun.

Procedure:

- 1 Depress the brake pedal. The brake pedal should be depressed during the entire procedure.
- 2 Hold B in RESUME for three seconds.
- 3 Release B.  
Idling speed will fall to the lowest possible setting.
- 4 Adjust engine speed with SET (A).
- 5 Hold B in RESUME and at the same time depress SET (A) for more than three seconds.

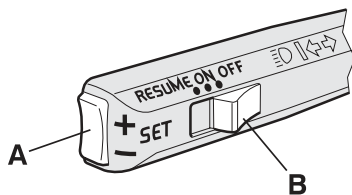

J0008305

## 12 Starting and stopping

---

- 6 Release the switches.
- 7 Release the brake pedal.  
The new idling speed is set.

If an error has been made during the adjustment sequence the previous idling speed will be retained.

### Fuel heater

Trucks equipped with Fuel Heater have electrically heated fuel lines which prevents the fuel from freezing on its way to the engine. Fuel Heater is used in extreme cold conditions to heat the fuel before starting and while driving.

Activate the function by pressing in the switch in the instrument panel. For the fuel to be warmed up before starting, the function should be activated at least 5 minutes before starting.

Fuel Heater is active as long as the switch is held pressed in, but the effect varies according to needs. The function is switched off automatically when the ignition is switched off.

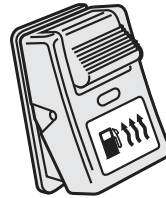

Switch for fuel heater

J192368

Overview

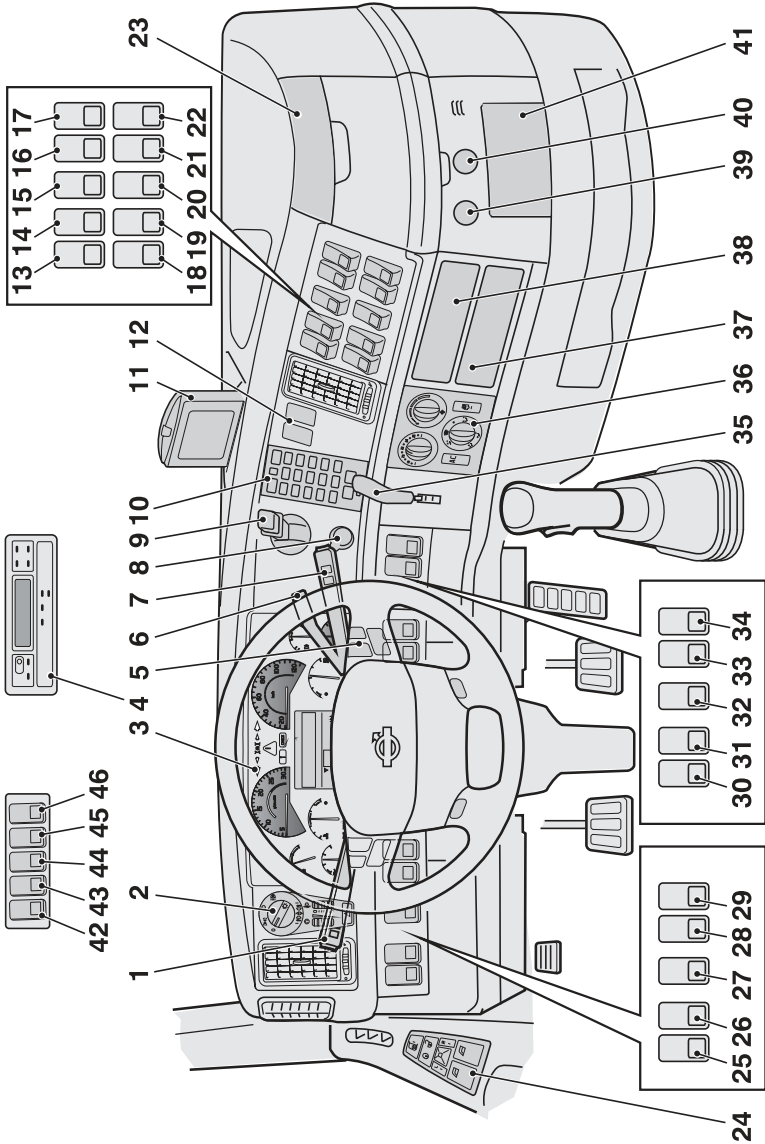



# 14 Instruments and controls

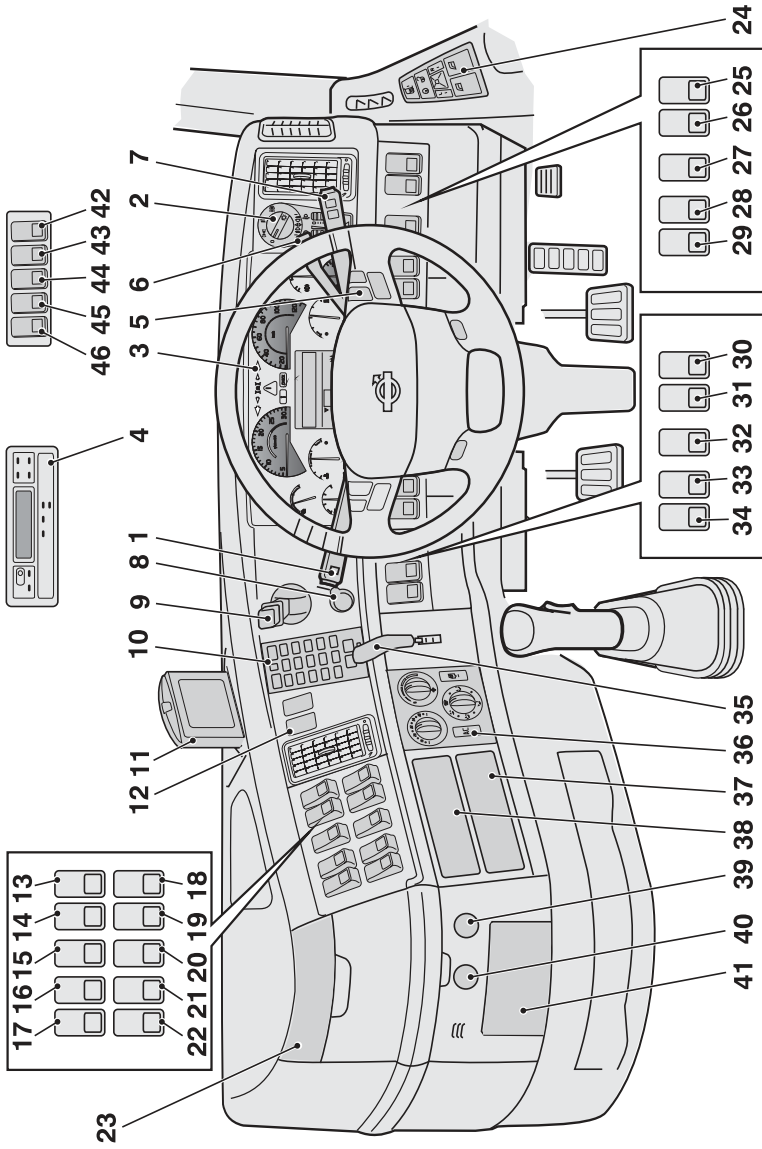

- 1 Stalk for direction indicators, cruise control and engine speed control
- 2 Lighting control panel
- 3 Instrument with driver information display
- 4 Tachograph
- 5 Buttons for radio and telephone
- 6 Stalk for auxiliary brake
- 7 Stalk for windscreen wiper and driver information display
- 8 Blocking valve
- 9 Parking brake
- 10 Phone
- 11 Display for Dynafleet and reversing camera
- 12 Buttons for Dynafleet and integrated telephone
- 13 - 22
  - Switch for reversing lights
  - Switch for rotating beacon
  - Switch for reversing camera
  - Switch for parking heater
  - Switch for inner lighting
  - Switch for auxiliary brake
  - Switch for bogie lift
  - Switch for differential lock
  - Switch for ADR
  - Switch for front wheel drive
  - Switch for cornering lights
  - Switch for switching off movement sensor
  - Switch for Volvo Action Service
  - Switch for panic alarm
- 23 Bottle holder
- 24 Door control panel

# 16 Instruments and controls

---

25-29	Switch for working lights
	Switch for hydraulic kit or body
	Switch for container lock
	OBD-outlet
30-34	Switch for fifth wheel
	Switch for spotlights
	Switch for cab tilt
	Switch for power take-off
	Switch for Emergency Assistance Button
35	Stalk for trailer brake or switch for trailer brake, EBS or extra equipment
36	Climate control system
37	Radio, tachograph or Dynafleet
38	Radio or Dynafleet
39	USB port
40	Electrical outlet 12 V (Max 10 A)
41	Ashtray
42	Roof sign
43	Electric roof hatch
44	Thermostat
45	Spotlights
46	Switch for cab interior lighting

## Gauges

### Tachometer

The tachometer is divided into three fields indicated by LEDs: Green LEDs, red LEDs and a field between them with extinguished LEDs.

Use the green zone for normal driving.

Use the extinguished zone for engine braking.

Never let the engine go into the red zone.

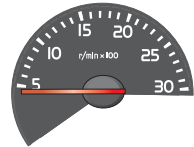

J201128

### Charge pressure gauge

To give good fuel economy, the needle should stay still when driving on a flat road.



J201133

### Oil pressure gauge

If the warning lamp lights up stop immediately and switch the engine off! Investigate the cause. If the lamp lights while the engine is running, an acoustic alarm sounds. In addition the STOP lamp lights and a warning message is shown on the display.

When driving with the engine at normal temperature, the needle should stay between 3 and 5.5 bar (300–550 kPa). The oil pressure may drop when the engine is idling. This is not dangerous if the oil pressure increases again when engine speed increases.

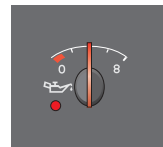

J201132

# 18 Instruments and controls

---

## Temperature gauge for coolant

Stop immediately if the warning lamp lights! Let the engine idle until the warning lamp goes out and the temperature drops.

Under normal driving conditions, the pointer should stay below the red zone.

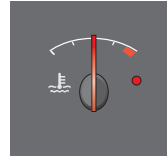

J201131

## Fuel gauge

When the warning lamp lights, there is 7–10% of the fuel left in the tank.

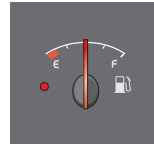

J201134

## Air pressure gauge for brakes

Stop immediately if a warning lamp lights! If the lamp lights while the engine is running, an acoustic alarm sounds. In addition the STOP lamp lights and a warning message is shown in the display. The warning lamp lights if the air pressure in the braking system is too low. Investigate the cause of the pressure drop.

When the engine is started after it has not run for a while, the air pressure can have dropped to a level too low for driving away. The warning lamp will remain lit until the air pressure has risen to the correct level. If there is no air in the braking system, it can take some time before the indicator needle begins to move.

During driving the needle should remain within the green zone, but when braking it may go below the green zone for a short time.

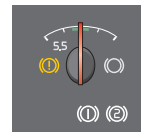

J201135

When “1” lights, the gauge shows the air pressure in the front brake circuit and when “2” lights, the air pressure in the rear brake circuit is shown.

### Level gauge for AdBlue







This gauge indicates the approximate amount of AdBlue in the tank. The red sector and the yellow LED indicate when AdBlue should be filled.















J201136



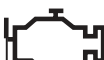

## Symbols

The symbols shown on the driver information display are described in section describing the display.

Symbol	Meaning	Note
	Left indicator on	In the case of a fault the arrow flashes twice as fast.
	Left indicator on (trailer)	In the case of a fault the arrow flashes twice as fast. Note! Fault indication will not occur if LEDs are used for the trailer lighting.
	Stop, there is a fault on the truck	Lights up together with another symbol or with a message on the display.
	Seat belt reminder	
	Parking brake applied	
	Check	Lights up together with some other symbol or together with a message on the display.

## 20 Instruments and controls

Symbol	Meaning	Note
	Information	Lights up together with some other symbol or together with a message on the display.
	ACC (Adaptive Cruise Control)	Green lamp = ACC has detected a vehicle. Red lamp = collision warning, driver must brake.
	Low split gear engaged	
	Main beam on	
	Front fog lamps on	
	Rear fog lamps on	
	Emissions-related fault	Contact a workshop; a fault has occurred in the engine which can have negative environmental effects.
	Battery not charging	
	Pre-heating on	
	Front wheel drive engaged	
	Differential lock engaged between the front wheels	
	Differential lock engaged between wheels	Flashes
	Differential lock engaged between axles	

Symbol	Meaning	Note
	Check the tachograph	Refer to the error menu in the tachograph display.
	The bogie lift switch is on.	On trucks equipped with A-ride, the symbol indicates the end position.
	The trailer bogie lift switch is on	
	ABS fault on tractor vehicle	If the symbol lights up at speeds exceeding 7 km/h, the ABS is disengaged. The braking system operates as if no ABS is available.
	ABS fault on trailer	



## Lighting and headlamps

The equipment may vary in different markets.

### Headlights

- **Parking lights:** Turn the lighting switch (1) to b.
- **Dip beam:** Turn the lighting switch (1) to c.
- **Main beam:** Turn the lighting switch (1) to c and pull the main beam stalk towards you.
- **Main beam and additional lamps (spotlights):** Turn the lighting switch (1) to d and pull the main beam stalk towards you.

- 1 Lighting switch
- 2 Indicator for front fog lamp
- 3 Indication (repeater) for rear fog lamp
- 4 Instrumentation lighting
- 5 Vertical adjustment of headlamps (extra)
- 6 Hazard warning flashers

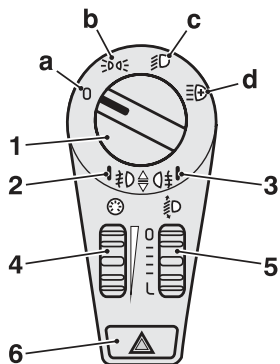

J0010330

### Day Running Light

Turn the lighting switch (1) to position a. The dipped beam and the parking lamps will come on when the engine is started.

### Fog light

The light switch (1) must be positioned in b, c or d for the fog lamp to come on. In position b, the rear fog lamps only function if the front fog lamps are lit.

- **Front fog lamp:** Push the lighting switch in (1). Indicator lamp (2) lights. Extinguish the fog lamp by pressing in the lighting switch (1) again.
- **Rear fog lamp:** Pull out the lighting switch (1). The indicator lamp (3) and the control lamp light up. Extinguish the rear fog lamp by pulling out the lighting switch (1) again.

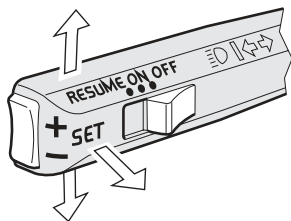

J3015656

Stalk for main beam and direction indicators.

The fog lamps go out if the lighting switch (1) is set to position a or if the ignition is turned off. If the lighting switch (1) is set to another position again or if the ignition is turned on again, the fog lamps must be turned on manually again.

### Guide lights (PS-LIGHT)

Certain parts of the exterior lighting (main and dipped beam, parking lights) can be kept lit and function as guide lights after the truck has been locked. The time delay can be set between 0 and 254 seconds and is done at a workshop.

- The key should be in position 0.
- The function is activated by holding the “main beam and direction indicator” stalk in position 1 for 3 seconds.
- Step out of the truck and lock the door.

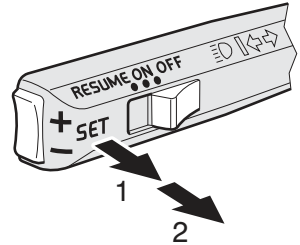

J201647

Pressing the lock button on the remote control once more resets the timer so that the selected time starts again from zero.

The function is inactivated by holding the “main beam and direction indicator” stalk in position 1 for 3 seconds.

### Dipping for left-hand or right-hand traffic

The headlamps are asymmetrical, which means that trucks for right-hand traffic have the light beam concentrated to the right and for left-hand traffic to the left. When a truck for right-hand traffic is driven in a country with left-hand traffic, the oncoming traffic is therefore dazzled.

To eliminate this problem:

- 1 Fold out the headlamp.
- 2 Remove the cover for the lower lamp.
- 3 Move the lever on the side of the lamp towards the truck.

To change back again, move the lever away from the truck.

### Static cornering light

Static cornering lightlights up dark areas when turning left and right.

The light is activated by a switch in the instrument panel. Light on each respective side is lit when:

the speed is below 40 km/h

and

the flashers for either direction are on



J192304

### Identification lamps

Activate the identification lamps by pressing the switch. An indicator LED in the switch lights.

Switch off the identification lamps by pressing the switch again. The LED in the switch goes out.

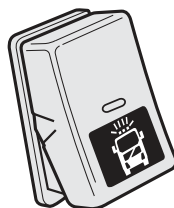

## Windscreen wipers

### Function

- 1 Intermittent wiping
- 2 Spring-return position
- 3 Windscreen wiper, normal speed
- 4 Windscreen wiper, high speed
- 5 Windscreen washers and wipers and headlamp washer

The time intervals for the intermittent wipers can be adjusted by the slide control on top of the stalk. The interval time can be set from 1 to 10 seconds.

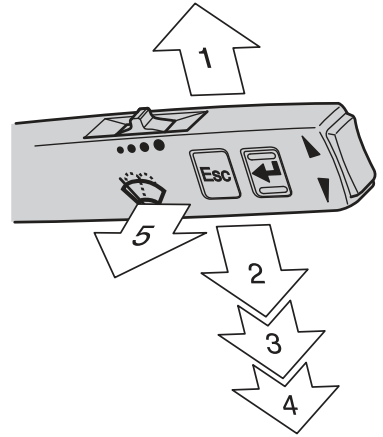

J166524

## Rain sensor

If the truck is fitted with a rain sensor, it senses the amount of rain against the windscreen and determines the speed of the windscreen wipers.

The sensitivity of the rain sensor can be adjusted with a slide control on top of the stalk.

### Note!

Note! The sensitivity of the rain sensor can vary in different weather conditions.

## Function

- 1 Rain sensor on
- 2 Spring-return position
- 3 Windscreen wiper, normal speed
- 4 Windscreen wiper, high speed
- 5 Windscreen washers and wipers and headlamp washer

The rain sensor can be switched off by moving the stalk to the neutral position for two to four seconds and then up again. The windscreen wiper is then in the intermittent mode. The interval is controlled by a slide control on top of the stalk. Repeat the procedure to reactivate the rain sensor.

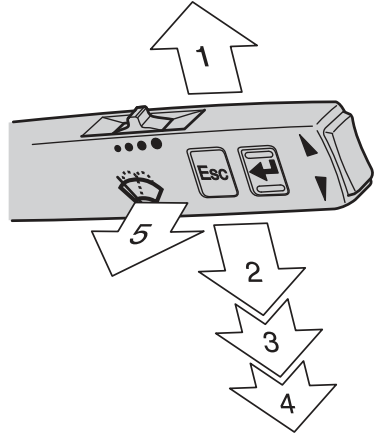

J166524

## Parking brake

### Hand control

0 Parking brake released

0-1 The parking brake for the tractor and trailer are applied gradually between positions 0 and 1. If a problem occurs with the service brakes, this position can be used as an emergency brake.

1 Parking brake applied on tractor unit and service brakes on trailer.

2 "Parking position". Parking brake released on the tractor unit, no brake on the trailer vehicle. The lever in locked position.

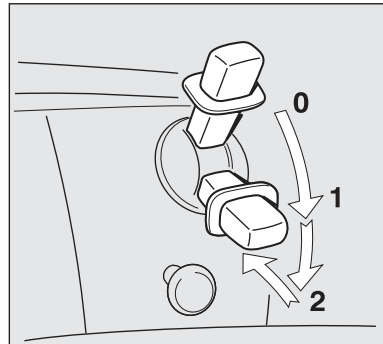

J5012236

 **Caution!**

Always apply the parking brake when you leave the vehicle. If the parking brake is not applied, a symbol on the display will start to flash, and at the same time an audible warning will sound to alert the driver.

 **Warning!**

Check that the lever is in locked position (position 2).

## Blocking valve

If the pressure in the braking system is too low, for example if the truck has been parked for a long period of time, the blocking valve must be pushed in for the hand-operated parking brake to be released. Before the blocking valve can be pushed in the pressure in the braking system must be approximately 5 bar.

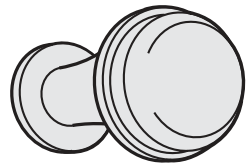

### Using the trailer service brake when parking

To ensure that the braking effect when parking a vehicle combo does not diminish due to air leakage, the spring brakes only are applied on the truck when parking. However, in certain situations, such as parking on slippery surfaces or on steep slopes with heavy loads, it can be advantageous to apply the trailer service brakes as well.

To activate the trailer service brakes for parking, pull the blocking valve button out until it remains out. The trailer brakes will now be activated as long as there is pressure in their brake systems.

#### **Note!**

As the pressure will gradually leak out from the trailer, this method should only be used temporarily and with the engine running. If the vehicle needs to be parked in this way (without the engine running) the wheels must be chocked or you must check that the vehicle remains parked (does not roll away) even without the help of the trailer's brakes.

## Trailer brake

### Note!

This control must not be used as a parking brake.



J0008056

## Electric trailer brake

Depress the switch to brake the trailer.

Speed must be less than 4 km/h for the brake to be engaged. The brake is disengaged if speed exceeds 7 km/h or when the switch is released.

When the brake is applied, the indication lamp in the switch lights up.

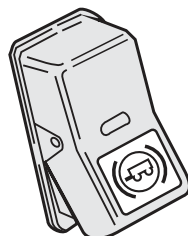

J0008526



## Air suspension

### Remote control box

More information about how the air suspension and control box can be used will be found in chapters "Driving" and "Loading and unloading".

Road speed must be lower than 30 km/h when the control box is used.

### Control buttons

To specify air suspension function:

- 1 STOP, cancels regulation.
- 2 Drive position, for normal driving.
- 3 Manual control.

Changing ride height.

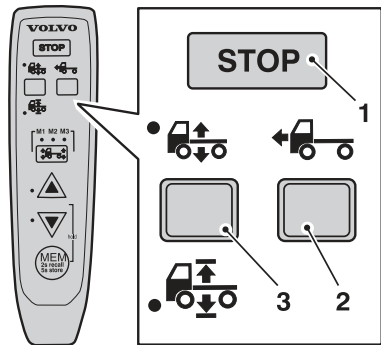

J7009817

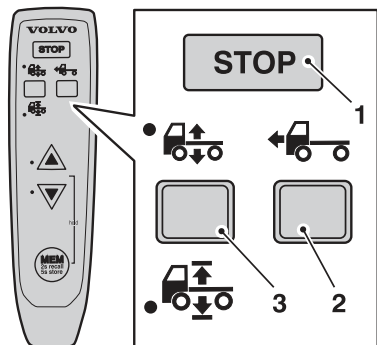

J7009830

## Axle button

To specify which axle is to be adjusted or which memory is to be used:

- M1, front axle or memory 1.
- M2, front and rear axle or memory 2.
- M3, rear axle or memory 3.

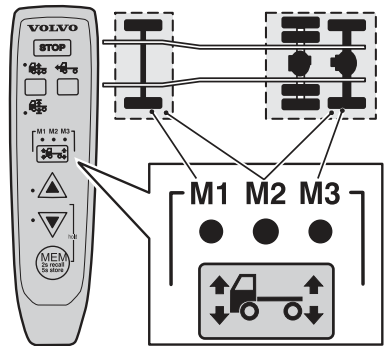

J7009818

## Control buttons

To raise or lower the truck.

To avoid having to hold in the control button, for example when raising or lowering the truck to its highest or lowest height, activate the hold function. Press one of the control buttons and at the same time press the memory button. To cancel the hold function, press the memory button again, one of the control buttons, or STOP.

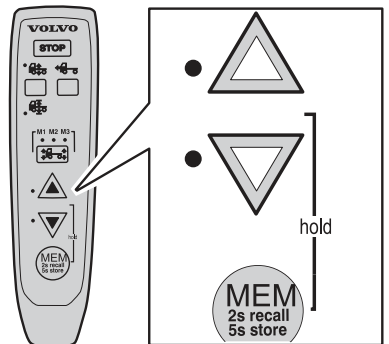

J7009819

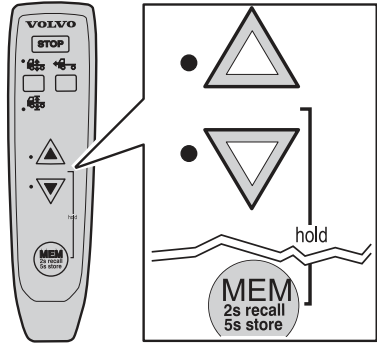

J7009831

## Memory button

To store or retrieve the memory content.

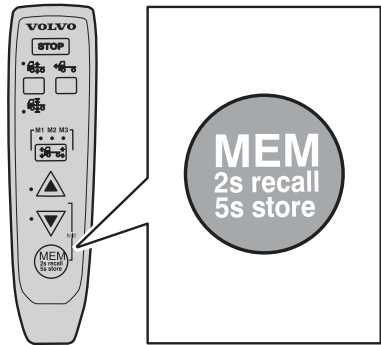

J7009820

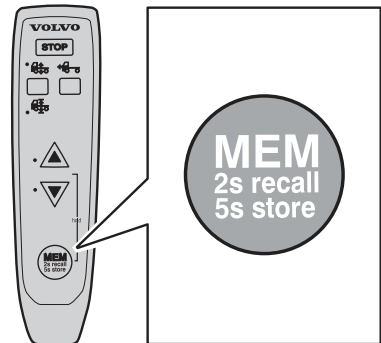

J7009832

## General, about the display

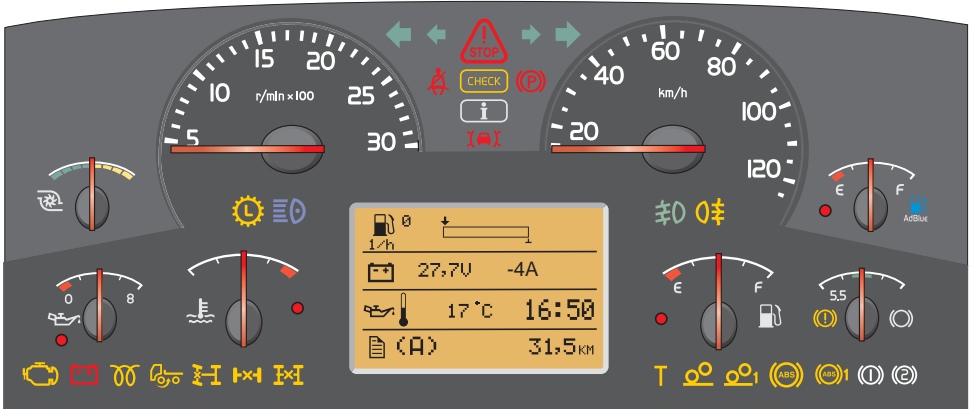

J201126

The display is located in the middle of the the instrument cluster. You can use the display to see vehicle messages, control certain functions on the truck and see information about the truck, amongst them temperatures, levels and distances.

The display is controlled via the control unit to the right of the steering wheel. There are four buttons:

- 1 Esc
- 2 "Select"
- 3 ▲
- 4 ▼

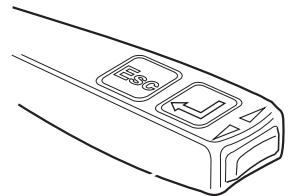

## The first that is shown

The display lights up when the key is turned to the drive position.

If there are no active vehicle messages, the favourite display is shown. You select what is to be displayed, see “favourite display, setting”.

The favourite display is shown all the time if there are no vehicle messages to show or unless you select one of the menus. To enter the menu system in the display, press “SELECT” on the control unit. See section “Menus” for more information about the menus.



If there are vehicle messages, these are shown instead of the favourite display. The number of the message shown and the total number are shown in the upper right corner. 3/3, for example, means that the vehicle message currently being displayed is the third message of three active messages. Step between the vehicle messages using ▲ and ▼. Take suitable actions and then acknowledge them with “Esc”. For more information about vehicle messages, see section “Messages and symbols”.

## General, about messages

If there is a fault in the truck or if something happens that requires attention, such as the outdoor temperature approaching freezing point, a vehicle message is displayed or a symbol appears in the display.

If several messages appear at the same time, only the most important message is displayed. Step between the vehicle messages using ▲ and ▼.

To obtain more detailed technical information about vehicle messages, see section “Fault diagnosis”.

	75°C	
	15°C	
	98°C	11:45 AM
CC	7658.8 Km	

## Information messages

When this light comes on a new information message is displayed. The lamp is used for information. The lamp being lit does not mean that there is a fault in the vehicle.



J3014366

Acknowledge the message with “Esc”. If the message is still valid, it will be shown again the next time the key is turned to the starting position. Previously displayed messages can also be seen at “Vehicle messages”.

If a message appears on the display and is acknowledged, it can appear on the display again if the reason for the message disappears after acknowledgement but then reappears.

**Example:** If the gearbox oil temperature becomes too high, a message is activated automatically. The driver acknowledges this message using “Esc”. If the temperature then drops to a normal level but then becomes too high again, the message will be shown again.

## Warning messages

Acknowledge the message with ”Esc”. If the fault is still active, it will be shown again next time the starter key is turned to the starting position. Previously displayed messages can also be seen at “Vehicle messages”. If a fault message appears on the display and is acknowledged, it can appear on the display again if the fault disappears after acknowledgement but then reappears again.

### Note!

This lamp lights when something must be rectified. If it is a fault on the truck, the truck shall be driven to a workshop for repair. The truck will not be damaged immediately and can in certain circumstances complete it's assignment first. It may also be something that the driver can correct himself, such as high temperature in the transmission, by driving more sedately or stopping the truck for a while.



J3014365

## Stop message

A buzzer sounds at the same time as a stop message is displayed. The buzzer and stop message can be acknowledged with "ESC", but will be repeated after 10 seconds. The symbol is lit continuously.



















<b>Warning!</b>
<p>When this lamp lights, the vehicle must be stopped immediately and the engine switched off. If the vehicle is not stopped and the engine turned off, there will be serious consequences for the vehicle, driver or load.</p>



J3014364

















## Alarm, warning and information symbols



















Symbol	Meaning	Symbol	Meaning
	High temperature, coolant		Crankcase pressure too high
	Low level, engine coolant		Engine fault
	Low oil pressure, engine oil		Engine speed too high

Symbol	Meaning	Symbol	Meaning
	Low oil level, engine oil		Low air pressure, gearbox
	High temperature, engine oil		Gearbox fault
	Pre-heating fault		Low level, gearbox oil
	High temperature, inlet manifold		Low oil pressure, gearbox
	Engine temperature too low for engine brake (VEB)		High temperature, gearbox oil
	Too high concentration of soot particles or ash in the particulate filter. See section "Particulate filter" for more information.		Parking brake applied
	Air filter clogged. Check that the net in the air intake is not clogged.		Brake pressure low
	Engine is switched off		Clutch running hot
	Cab tilt lock open		Temperature, hydraulic retarder





# 38 Information display

Symbol	Meaning	Symbol	Meaning
	<p>The compressor charge is unusually high. The cause could be air leakage.</p> <ul style="list-style-type: none"> <li>If the symbol is shown together with the information symbol (i), the leakage is so large that fuel consumption is increased.</li> <li>If the symbol is displayed together with the check symbol (CHECK), then the leakage is so large that it can cause an unplanned stop if not remedied.</li> </ul>		<p>Risk of moisture in the pneumatic system. There are several causes:</p> <ul style="list-style-type: none"> <li>Time to replace the desiccant element.</li> <li>The compressor is being used to much.</li> <li>Fault with the air system.</li> </ul>
	Fault in trailer EBS function		<p>Leakage from indicated tyre/axle. This warning may also occur after changing tyres. Disable by unscrewing the hose to the tyre pressure sensor on the tyre in question, wait for a minute and then screw on again. (Key in drive position)</p>
	Connected trailer without ABS		High tyre pressure
	Poor brake effect on trailer		Low tyre pressure
	Uneven braking effect between tractor and trailer		Baggage door open
	Low pressure in the air suspension system		Door open
	Wheel spin or ABS activated		Door to cargo hold open
	Traction Control Function temporarily disengaged		Airbag

Symbol	Meaning	Symbol	Meaning
	Trailer disconnected		Low level washer fluid
	Superstructure not in drive position		One or more lamps do not light.
	Air suspension in manual position		Fault in the electrical system causing lamp not to light. Can cause a hardware fault in the electronics.
	Air suspension not in drive position		Warning freezing conditions
	Low pressure or flow in steering servo. The symbol might be displayed when stationary or at low speeds without there being a fault.		Fuel filter clogged
	Stop		Low fuel level
	Voltage warning		Stability control active
	Battery discharge		Diagram sheet box open or sheet for driver 1 missing. (Only for certain variants)
	Alarm in service mode.		Service reminder









## Symbols for air suspension

Symbol	Meaning	Action
	The control button is set to manual control or adjustment of ride height.	Select ride height <b>Note!</b> Drive very carefully when the symbol is displayed.
	If the control button is in the centre position the air suspension is in locked position.	Check whether the air suspension is locked: Turn the ignition key to the stop position (0) and then back to the drive position (I). If the symbol remains on the display the air suspension is locked. See section "Air suspension in locked position", page 628.
Axle load distribution 70%	With "optimise traction", the axle load distribution is shown in the display.	None. The message disappears when optimal load distribution has been achieved.
	Truck not in drive position.	Check that the control button is in the drive position and wait until the truck reaches the correct drive height. <b>Note!</b> Drive very carefully when the symbol is displayed.  A signal will sound if the speed is too high. If a bellows is punctured, drive, at not more than 30 km/h, to a Volvo workshop, or contact Volvo Action Service.
CHECK THE AIR SUSPENSION AT THE NEXT STOP	There is an air suspension malfunction.	Check whether the fault is active at the next stop: Turn the ignition key to the stop position (0) and then back to the drive position (I). If the message remains in the display, the fault is active. See section "Air suspension in locked position".

## Status symbols

Status symbols are shown in the lowest row of the display.

Symbol	Meaning	Symbol	Meaning
	Air intake heating or air intake heating fault	<b>LCS</b>	Lane Change Support active

Symbol	Meaning	Symbol	Meaning
	Parking heater timer activated	<b>CC</b>	Cruise control active
	Alarm clock activated	<b>ACC</b>	Adaptive cruise control active
	Message active	<b>(A)</b>	Auxiliary brake position A
	Water in fuel (draining required)	<b>(1)</b>	Auxiliary brake position 1
	Auxiliary brake working	<b>(2)</b>	Auxiliary brake position 2
<b>MI</b>	Odometer, miles	<b>(3)</b>	Auxiliary brake position 3
<b>KM</b>	Odometer, kilometres	<b>(B)</b>	Auxiliary brake position B
<b>PTO</b>	Power take-off active		ATS (Aftertreatment system) inactive
	High temperature, exhaust system		Lane Keeping Support(LKS) active
	Lane Keeping Support (LKS) inactive		

## Other Symbols

There are even more symbols within different menus that have not been included here. See the description of the menu in question for an explanation.

## Menu structure

### Menus when driving

- 1 Gauges
  - 1.1 Temperature, outside
  - 1.2 Temperature, engine oil
  - 1.3 Temperature, gearbox
  - 1.4 Voltmeter/Ammeter
  - 1.5 Gear position
  - 1.6 Pressure, primary tank
- 2 Fuel data
  - 2.1 Fuel consumption
  - 2.2 Stage data
  - 2.3 Remaining fuel
  - 2.4 AdBlue
- 3 Time/distance
  - 3.1 Tripmeter
  - 3.2 Average speed
  - 3.3 Estimated arrival time
  - 3.4 Clock and Date
  - 3.5 Alarm clock
  - 3.6 Driving/rest time
- 4 Display
  - 4.1 Black panel
  - 4.2 Backlight
  - 4.3 Favourite display, setting
  - 4.4 Night/Day
- 5 Vehicle messages
- 6 Tyre pressure
- 7 Reset
  - 7.1 Reset

- 8 ATSt<sup>1</sup>
  - 8.1 Start regeneration
  - 8.2 Activate/Deactivate ATS
  - 8.3 System conditions
  - 8.4 Soot/ash level

<sup>1</sup> Only on trucks with variants JPN07 and EAS-DPF

## **Menus when stationary**

- 1 P-heater timer
  - 1.1 Programming
  - 1.2 Reset
- 2 Display setting
  - 2.1 Language
  - 2.2 Units
  - 2.3 Time/Date
  - 2.4 Display light
  - 2.5 Change password<sup>1</sup>
- 3 Vehicle Settings
  - 3.1 Traction control
  - 3.2 DAS
  - 3.3 LCD
  - 3.4 Fleet Limits<sup>1</sup>
  - 3.5 Current sensor calibration
  - 3.6 Fleet ID<sup>1</sup>
  - 3.7 Day running lights automatic
  - 3.8 Draining/priming
  - 3.9 Set wheel ID
  - 3.10 Set reference pressure
- 4 Diagnostics
  - 4.1 Fault diagnostics
  - 4.2 Cluster selftest
  - 4.3 Part number

## 44 Information display

---



- 5 Vehicle data
  - 5.1 Oil level
  - 5.2 Load indicator
  - 5.3 Brake linings, status
- 6 Maintenance
  - 6.1 Service Warning

<sup>1</sup> Password protected menu.

## Show menus

If no other message is shown, the favourite display will be shown. To enter the menu system, press "SELECT" on the control unit.

For reasons of safety, not all menus are available when driving. To see certain menus and to make certain settings, the truck must be stationary.

	75 °C
	15 °C
	98 °C 11:45 AM
	7658.8 km

## Step between the menus

- 1 Move the cursor between menus using ▲ and ▼. The order number of the marked menu is shown in the top right corner. 2/6 indicates that there are 6 menus and that the current menu is number 2.
- 2 Go from a menu to a sub-menu using "SELECT".
- 3 Leave a sub-menu with "Esc".

## Change a setting

Example:

The display shows the favourite display and you wish to set the alarm clock to ring at 05:45.

- 1 Go to the menus using "SELECT".  
Put the cursor on "Time/Distance" with ▲ and ▼.



## 46 Information display

---

- 2 Press "SELECT".  
The current time and date are shown.
- 3 Step the alarm clock with ▲ and ▼.
- 4 Press "SELECT".  
Step down to "NEW TIME" with ▲ and ▼.
- 5 Press "SELECT".  
The hours are marked.  
Step to the required hour using ▲ and ▼.
- 6 Press "SELECT".  
The first digit for minutes is marked.  
Step to the required digit using ▲ and ▼.
- 7 Press "SELECT".  
The second digit for minutes is marked.  
Step to the required digit using ▲ and ▼.
- 8 Press "SELECT".  
"ON" is marked.
- 9 Press "SELECT".  
A cross is placed in the box in front of "ON" and the symbol for activated alarm clock is shown in the status bar. The alarm clock setting is then automatically displayed.
- 10 Go back to favourite display with "Esc". The symbol for activated alarm clock is shown in the status bar.  
To deactivate the alarm clock:
  - Enter the "Time/Distance" menu with "SELECT".
  - Step the alarm clock with ▲ and ▼.
  - Press "SELECT".
  - Step to "OFF" with ▲ and ▼.
  - Press "SELECT".

## Temperature, outside

The temperature outside the cab.



J3005101

## Temperature, engine oil

Temperature of the engine oil.



J3013611

## Temperature, gearbox

Temperature of the gearbox oil.



J3005098

### Note!

Temperatures below 45°C are not shown.

## Voltmeter/Ammeter

Voltage values less than 20.0 V are presented as LOW if the engine speed is less than 800 rpm for 10 minutes. The voltage values higher than 30.0 V are presented as HIGH.

If the ammeter's value becomes too low, the ammeter's value is shown automatically as well as the text "Discharge".



J3008832

## Gear position

The menu "Gear position" shows information about engaged gear, lever position, available gears etc.

For further information about "Gearbox", see separate driver instructions "I-shift" and "Powertronic".

## Pressure, primary tank

If the pressure in the primary tank drops below 8 Bar, a fault message is displayed together with the info/warning symbol.

Air-suspended vehicles work with two pressure levels:

- Maximum system pressure at standstill (and low speed)
- Reduced system pressure when driving (reduce fuel consumption and wear on air compressor)

Certain variants do not have reduced system pressure.



J3016142

## Fuel consumption

For setting the units, see section "Units".

### Average fuel consumption:

The value is presented as a figure and an arrow pointing down, (e.g. 026.) During a time after resetting the display shows "— —" while average fuel consumption is calculated.

### Instantaneous fuel consumption:

The value is presented numerically as well as in the form of a bar.

### Target fuel consumption:

The value is displayed as a T upside down below the bar. For information on setting this value, see section "Fuel (target)".

### Reset fuel consumption

Press "SELECT".



J3014498

### Note!

At idle, no bar is shown and the fuel consumption is displayed in litre/hr (alternatively gallons/hr).

To reset **all** fuel data, hold “SELECT” pressed in for 1 second.

Stage data is also reset.

## Leg data

The amount of fuel consumed since the last reset.



J3013617

## Resetting, stage data

Press “SELECT”.

To reset **all** stage data, hold “SELECT” pressed in for 1 second.

Fuel consumption (see above) is also reset.

## Remaining fuel

- How far one can drive at the current average consumption
- How much fuel is left in the tank



J3014498



J0010376

## AdBlue

How much AdBlue is left in the tank.



J0013296

### Trip meter

Two independent distances can be saved, for leg 1 and leg 2.



J0009587

#### Note!

The trip values must be reset before each measurement.

### Reset trip meter

- 1 Press "SELECT".
- 2 Mark with ▲ and ▼ if leg 1 or leg 2 is to be reset.
- 3 Confirm selection with "SELECT" or depress "Esc" to exit reset.

### Average speed

The average speed is calculated as the distance driven divided by the time the engine has been running (since latest reset). Two different average speeds can be measured, average speeds 1 and 2.



J3013620

#### Note!

The values must be reset before each measurement.

### Reset average speeds

- 1 Press "SELECT".
- 2 Mark with ▲ and ▼ if average speed 1 or 2 is to be reset.

- 3 Confirm selection with "SELECT" or depress "Esc" to exit reset.

## Estimated time of arrival

The estimated time of arrival is calculated as the remaining distance divided by the vehicle's average speed.



J3013621

### Show distance

- 1 Press "SELECT".
- 2 Enter the remaining distance in km (or miles)

- Set the first digit with ▲ and ▼
- Step to the next digit using "SELECT"
- Step backwards with "Esc"

## Time and Date

The menus "Time and date" and "Alarm Clock" are available even when the starter key is in the stop position. The menu is activated by pressing any of the buttons on the control unit for at least 1 second. The menu remains active for 30 seconds after the last depression.



J3013618

Current time and date. For alternative settings 12h or 24h and date format, see section "Time/date".

The clock cannot be altered if the truck is equipped with a tachograph. This is then done in the tachograph time setting menu instead (see "Operating instructions Tachograph").

- 1 Press "SELECT".
  - 2 Set Time and Date
- Set the first digit with ▲ and ▼
  - Step to the next digit using "SELECT"

- Step backwards with "Esc"

If the starter key is in stop position and it takes more than 30 seconds between button depressions, the setting is aborted.

### Alarm clock

The menu "Alarm Clock" is available even when the starter key is in stop position. The menu is activated by pressing any of the buttons on the control unit for at least 1 second. The menu remains active for 30 seconds after the last depression.

The alarm clock cannot be set when driving, but the buzzer that sounds when triggered can be shut off by pressing "Esc".

#### Alarm clock, setting

- 1 Press "SELECT".
- 2 Move the cursor to NEW TIME using ▲ and ▼.
- 3 Confirm with "SELECT".
- 4 Enter the alarm time  
Set the first digit with ▲ and ▼  
Step to the next digit using "SELECT"  
Step backwards with "Esc"
- 5 "ON" is then marked. Confirm with "SELECT".  
The symbol to the right is shown on the status bar to indicate that the alarm clock is active.



J3013619

If the starter key is in stop position and it takes more than 30 seconds between button depressions, the setting is aborted.

#### Activate alarm clock

Activating the alarm clock without changing alarm time:

- 1 Press "SELECT".
- 2 Move the cursor to "ON" using ▲ and ▼.
- 3 Confirm with "SELECT".

- 4 The symbol for activated alarm clock is shown on the status bar in the display.

## Switch off the alarm clock

When the alarm clock goes off, the word ALARM lights up, the current time is displayed and a warning signal is sounded. The alarm shuts off after 60 seconds or if "ESC" is depressed.

## Driving/rest time

Information about driving and rest times are taken from the digital tachograph (the function is an option).

The symbol is at the far left and the information under it varies depending on the selected activity in the digital tachograph. The symbol in the centre indicates pause and rest time. The symbol to the right indicates driving time



## Black Panel

When "Black Panel" is active, only the speedometer and tachometer are illuminated (except the coloured field).

The following events light the backlighting:

- a message is activated
- a button is depressed
- the engine speed enters the red zone on the tachometer

## Backlight

The display lighting follows the rheostat setting (which also controls the other instrument lighting). This menu can be used to alter the display lighting with respect to the lighting of the other instruments.



## Set backlight

- 1 Increase or decrease the backlighting with ▲ and ▼.
- 2 Confirm with "SELECT".
- 3 "Esc" aborts the setting.



J0009588

## Favourite Display, setting

Select which of 13 different gauges and functions to be shown in "Favourite display".

No display

Outside temperature



Temperature, engine oil



Temperature, gearbox oil



Voltmeter/Ammeter



Gear position

Remaining AdBlue



Fuel consumption



Remaining fuel



Stage data



Trip meter



Average road speed



Estimated arrival time



Time/Date

Alarm

Tacho info

Compass

DAS



- 1 Press “SELECT”.
- 2 Press “SELECT” once more and the upper field becomes active. Select the gauge or function using ▲ and ▼. Acknowledge with “SELECT” when required gauge or function is shown.
- 3 Press “SELECT” once more to activate the next field. Select the gauge or function using ▲ and ▼. Acknowledge with “SELECT” when the required gauge or function is shown.
- 4 Press “SELECT” or “Esc” until all the fields are active and the clock is shown.

## Night/Day

This function is used to activate daylight mode (white text on a black background) and night mode (black text on a white background). When the daylight mode is active, the display changes to night mode if the lighting is turned on.

## Vehicle Messages

If a message is displayed and acknowledged, a symbol is shown in the status bar. Go into this menu to see which messages have been acknowledged without being rectified.

Switch between messages using ▲ and ▼.

Press "ESC" to return to the main menu.

An acknowledged message that is still active the next time the starter key is turned to drive position will be displayed as an unacknowledged message. The message symbol will stay on as long as there are unacknowledged messages present.

## Tyre pressure

This function checks the tire pressures on the truck and the trailer (if applicable) if the option TPM (Tyre Pressure Monitoring) is installed.

Switch between measurement points using ▲ and ▼.

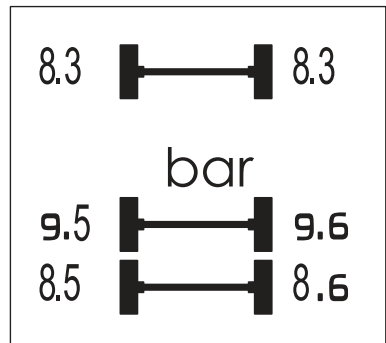

**Note!**

The data in the display can vary depending on how many axles and tyre pressure sensors are fitted to the truck.

**Note!**

It is only possible to read off the tyre pressure when the truck is stationary.

## Set wheel ID

- 1 Select axle with ▲ and ▼
- 2 Confirm selected axle with "SELECT".
- 3 Select wheel with ▲ and ▼
- 4 Confirm selected wheel with "SELECT".
- 5 Current ID is shown.
- 6 Adjust "New ID".  
Adjust the marked digit with ▲ and ▼  
Confirm each selected digit with "SELECT".
- 7 Confirm change of ID with "SELECT".

Press "Esc" to return to previous digit, row or menu.

## Set reference pressure

- 1 Select axle with ▲ and ▼
- 2 Confirm selected axle with "SELECT".
- 3 Current value is shown
- 4 Adjust "New value".  
Adjust the marked digit with ▲ and ▼  
Confirm each selected digit with "SELECT"
- 5 Confirm reference pressure with "SELECT"

Press "Esc" to return to previous digit, row or menu.

## Reset

If "SELECT" is depressed for more than 1 second, the following functions are reset:

- Fuel consumption
- Leg data
- Tripmeters 1 & 2
- Average speeds 1 & 2

## ATS

(Only JPN07 and EAS-DPF)

The truck has an exhaust after-treatment system (ATS) that includes a diesel particulate filter (DPF). When a certain quantity of soot and ash particles have been collected, regeneration of the filter is necessary. See also section "Diesel particulate filter".



### Caution!

The silencer becomes extremely hot during regeneration. Therefore avoid driving or stopping the truck in unsuitable places, for example, in tunnels, in fields or close to inflammable materials or gases.

## Start regeneration

This function is used when regeneration must be started manually.

When regeneration starts, a symbol is shown to the right and the message "Regeneration in progress" is shown in the display.



When regeneration starts the symbol High temperature, exhaust system is shown in the display.

J3018100

If manual regeneration fails, the message "Regeneration failed . Check system conditions." is shown in the display. To find out why the regeneration failed, select "System conditions"(see below) and check the system conditions.

## Note!

If regeneration is performed while the engine is idling, the idle speed may rise.

## Abort regeneration

Regeneration can be aborted at any time by:

- turning off the ignition, or
- deactivating ATS (see below)

## Activate/Deactivate ATS

To activate/deactivate ATS:

- 1 Choose "Activate/deactivate regeneration" with ▲ and ▼.
- 2 Confirm with "SELECT"
- 3 Abort with "Esc"

When ATS is deactivated, the following symbol is shown on the display. Reactivated ATS as soon as possible.



J129144

## System conditions

This function shows the status of the system conditions that must be fulfilled for regeneration to start (applies only to **manual** start of regeneration). The system conditions can have the status OK, CHECK or N/A. For regeneration to function, all conditions must have status OK. If any of the conditions has status CHECK, then regeneration cannot be performed. N/A means that the condition does not apply to this truck. See all the system conditions below.

## 60 Information display

---

The following table shows the system conditions and the requirements for them to be fulfilled.

System conditions	Status OK if:
Clutch	Clutch not depressed
PTO	PTO not activated
Accelerator pedal	Accelerator pedal not depressed
Gears	Gearbox in neutral
Vehicle speed	Truck stationary
Handbrake	Handbrake applied
System fault	Component fault, engine, or diesel particulate filter do not prevent regeneration <b>Action:</b> Contact a Volvo workshop
Temporary system lockout	Soot level <b>is not sufficiently high</b> to start regeneration <b>Action:</b> Continue driving as normal until the soot level requires regeneration
Permanent system lockout	The soot level is <b>too high</b> to permit regeneration <b>Action:</b> Stop the truck immediately and contact your nearest Volvo workshop
Engine	Engine running and warmed up
Inactivation switch	“Inactivate ATS” selected by driver

### Soot/ash level

The function shows the amount of soot and ash collected in the filter graphically

Choose which image to show with ”▲ and ▼”.

### Programming, p-heater timer

If the timer already has a time set, it will be shown.

1 Press "SELECT".

- 2 Move the cursor to "Programming" using ▲ and ▼.
- 3 Confirm with "SELECT".
- 4 Set the start date with ▲ and ▼  
Current date is default.
- 5 Confirm with "SELECT".
- 6 Set the start time with ▲ and ▼
- 7 Confirm with "SELECT".
- 8 Set duration with ▲ and ▼  
The time is changed in 10 minute intervals. The longest time that can be set is 2 hours.
- 9 Confirm with "SELECT".
- 10 The set time and date are shown.
- 11 Confirm with "SELECT".

## Reset, p-heater timer

- 1 Press "SELECT".
- 2 Move the cursor to "Reset" using ▲ and ▼.
- 3 Confirm with "SELECT".

## Language

- 1 To set the required language press "SELECT".
- 2 The display now shows up to three different languages. Select the desired language by moving the cursor to the row concerned with ▲ and ▼. Confirm the choice with "SELECT".

## Units

### Distance

Select if the trip should be shown as km or miles.

- 1 Mark the desired unit with ▲ and ▼.
- 2 Confirm with "SELECT".
- 3 "Esc" aborts the setting.



### Fuel consumption

Select if fuel consumption is shown as km/l, l/100 km, miles per gallon (mpg) with IMP gallons or as miles per gallon (mpg) with US gallons.

- 1 Mark the desired unit with ▲ and ▼.
- 2 Confirm with "SELECT".
- 3 "Esc" aborts the setting.

### Temperature

Select if temperature shall be shown as Celsius (°C) or Fahrenheit (°F).

- 1 Mark the desired unit with ▲ and ▼.
- 2 Confirm with "SELECT".
- 3 "Esc" aborts the setting.

### Pressure

Select if pressure should be shown as psi or bar.

- 1 Mark the desired unit with ▲ and ▼.
- 2 Confirm with "SELECT".
- 3 "Esc" aborts the setting.

## Time/Date

### Time

- 1 Mark the time format with ▲ and ▼.
- 2 Confirm with "SELECT".
- 3 "Esc" aborts the setting.

In the AM/PM-format the time only goes to 12 and then starts again from 1. AM is morning and PM is afternoon.

### Date

Select if the date is to be shown as year, month, day (yymmdd), or day, month, year (ddmmyy) or as month, day, year (mmdyy).

- 1 Select the date format with ▲ and ▼.
- 2 Confirm with "SELECT".
- 3 "Esc" aborts the setting.

## Display lighting

### Contrast

- 1 Increase or decrease contrast with ▲ and ▼.
- 2 Confirm with "SELECT".
- 3 "Esc" aborts the setting.



J0009588

### Backlight

The display lighting follows the rheostat setting (which also controls the other instrument lighting). This menu can be used to alter the display lighting with respect to the lighting of the other instruments.

- 1 Increase or decrease the backlighting with ▲ and ▼.
- 2 Confirm with "SELECT".
- 3 "Esc" aborts the setting.

### Night mode

This function is used for changing between white text on a black background and black text on a white background.

- 1 Mark if the night display should be active with ▲ and ▼.
- 2 Confirm with "SELECT".
- 3 "Esc" cancels the setting.

## Change password

First enter the current password.

- 1 Mark which password is to be altered with ▲ and ▼.
- 2 Confirm with "SELECT".

- 3 Set the first digit with ▲ and ▼
- 4 Step to the next digit using "SELECT"
- 5 Step backwards with "Esc"

### Traction control

- 1 Select "On" or "Off" with ▲ and ▼.
- 2 Confirm with "SELECT".
- 3 "Esc" aborts the setting.



J3014424

If traction control is switched off, a warning symbol is shown.

#### **Note!**

When testing on a roller bench or when towing with an axle raised, the TCS must be switched off.

### DAS

- 1 Select "On" or "Off" with ▲ and ▼.
- 2 Confirm with "SELECT".
- 3 "Esc" cancels the setting.



J153857

DAS level marking is only shown if it has been chosen as favourite display.

### LCS

- 1 Select "On" or "Off" with ▲ and ▼.
- 2 Confirm with "SELECT".
- 3 "Esc" cancels the setting.

## Fleet limits

### Engine speed (max)

Only accessible if correct password has been entered.

This setting gives the fleet owner the possibility to choose an engine speed limit. If the engine exceeds this limit, it will be registered, see section "Trip data".

- 1 Select "Engine speed (max)" with ▲ and ▼.
- 2 Confirm with "SELECT".
- 3 Enter a new engine speed limit (in rpm)  
Set the first digit with ▲ and ▼  
Step to the next digit using "SELECT"  
Step backwards with "Esc"
- 4 Confirm the new engine speed limit with "SELECT"
- 5 The message "Transfer complete" is shown

If the setting fails:

- Press "Esc" and try to do the setting one more time, see point 1.
- If it still will not work, perform diagnostics of the display and engine control unit, see section "Fault diagnosis".
- Contact a workshop if necessary.

## **Speed (max)**

Only accessible if correct password is entered.

This function makes it possible for the carrier to set a road speed limit. If the truck exceeds this speed it is registered, see section "Trip data".

- 1 Select "Speed (max)" with ▲ and ▼.
- 2 Confirm with "SELECT".
- 3 State a new speed limit  
Set the first digit with ▲ and ▼  
Step to the next digit using "SELECT"  
Step backwards with "Esc"
- 4 Confirm the new speed limit with "SELECT"
- 5 The message "Transfer complete" is shown

If the setting fails:

- Press "Esc" and try to do the setting one more time, see point 1.

- If it still will not work, perform diagnostics of the display and engine control unit, see section “Fault diagnosis”.
- Contact a workshop if necessary.

### Fuel (target)

Only accessible if correct password is entered.

This function makes it possible for the carrier to set a fuel consumption target. For information about fuel consumption for a journey, see section “Trip data”.

- 1 Select Fuel (target) with ▲ and ▼.
- 2 Confirm with "SELECT".
- 3 State a new fuel target  
Set the first digit with ▲ and ▼  
Step to the next digit using "SELECT"  
Step backwards with "Esc"
- 4 Confirm the new fuel target with "SELECT"
- 5 The message "Transfer complete" is shown

If the setting fails:

- Press "Esc" and try to do the setting one more time, see point 1.
- If it still will not work, perform diagnostics of the display and engine control unit, see section “Fault diagnosis”.
- Contact a workshop if necessary.

### Ammeter sensor calibration

Ammeter sensor calibration must be performed when a sensor or instrument is replaced.

Follow the instructions on the display. Cancel by pressing "Esc".

### Fleet ID

Only accessible if correct password is entered.

In this menu the carrier can enter the fleet ID of the truck if required. Data registered in the engine control unit is then registered for that ID.

- 1 Set new Fleet ID  
Set the first digit or letter with ▲ and ▼  
Step to the next digit using "SELECT"  
Step backwards with "Esc"  
13 digits must be entered (a space is entered for unused positions).
- 2 Confirm the new Fleet ID with "SELECT"
- 3 The message "Transfer complete" is shown

If the setting fails:

- Press "Esc" and try to do the setting one more time, see point 1.
- If it still will not work, perform diagnostics of the display and engine control unit, see section "Fault diagnosis".
- Contact a workshop if necessary.

## Trailer detection

Trailer detection can be shut off in this menu. A reason for deactivating trailer detection could be to avoid flashing lamps when using a trailer with LED rear lights. LCM can currently not detect the low current consumption of this type of lamp, so we recommend the use of normal filament lamps.

- 1 Select "On" or "Off" with ▲ and ▼.
- 2 Confirm with "SELECT".
- 3 "ESC" aborts the setting.

If trailer detection is "Off", the driver should observe the following:

- **Trailer indicator** in the display is not active (warning lamp).
- **I-shift** can select incorrect starting gear, which can result in an overloaded clutch. When coupling a

### Note!

A truck with inactivated trailer detection does NOT fulfil the legal requirements for fault indication of direction indicators on a trailer (according to ECE R48 6.5.8 warning lamp). Functioning lamps for direction indication on a trailer are obligatory.

### Note!

Remember to reset the trailer detection to "On". This is done in the same way as turning it off.

trailer, the starting gear should be adjusted manually if it is too high.

- **ESP** (electronic stability program) on trucks with EBS Gen 3 (manufactured from week 335). The ESP function will have a reduced functionality if trailer detection is turned off.
- **EBS** will have difficulty in calculating the correct total weight after coupling/uncoupling of a trailer, which can result in variable braking feeling.
- The warning in the display that the trailer has no ABS will not function. The warning that the trailer's ABS is out of order is not affected (it functions).
- **LCM** (lighting control module) will no longer report fault codes to the combination instrument, a situation that can occur with faults in the trailer lighting power outlet.

## Day running lights automatic

Day running lights automatic can be switched off in this menu. This means that if the day running lights automatic is “Off”, you must switch the dipped beams on and off with the lights knob in the panel.

- 1 Select “On” or “Off” with ▲ and ▼.
- 2 Confirm with “SELECT”.
- 3 “Esc” cancels the setting.

## Draining/priming

Draining/priming of the fuel system is done via this menu, when required.

Depending on whether it is draining or priming that is required, the display will show different messages. An icon is shown together with the text "Draining/priming request". The display also shows if draining or priming is not allowed.

The following conditions must be met before draining/priming can be carried out:



Draining

J3016141

- 1 Parking brake applied
- 2 Engine switched off
- 3 Ignition key in drive position
- 4 Symbol for "Draining/priming" must be lit (for draining, symbol for "Water in the fuel").



J3015665

## Priming

### **Note!**

To complete the draining/priming process, the conditions must be fulfilled during the whole of the process.

If the message "Draining/priming not allowed" is shown in the display, check first that conditions 1-4 are fulfilled.

## Fault diagnostics

A list of the truck control units is shown in the menu "Fault diagnostics".

Switch between control units using ▲ and ▼.

"SELECT" confirms choice of control unit. To cancel, press "Esc".

- 1 During the time that the selected control unit is polling, the display indicates that data transfer is taking place.
- 2 If the selected control unit has no faults "No faults" is displayed.  
Press "Esc" to return to the previous menu.
- 3 If the selected control unit does not reply within 5 seconds the following is shown "Operation failed" in the display.  
Press "Esc" and try once more, see point 1.  
Contact a workshop if necessary.
- 4 If the selected control unit has a fault code or fault codes, it displays
  - 1 Which control unit it applies to
  - 2 Which parameter or component is faulty
  - 3 Which type of fault it is
  - 4 If the fault is active or inactive
  - 5 How many times the fault has been registered since the last reset



- 5 If there are several fault codes or fault messages for the same control unit, you can scroll through the fault codes with ▲ and ▼. "Reset all" is shown last in the list. This resetting only clears the fault codes for the selected control unit.
- 6 If there are more than 20 fault codes/fault messages for the selected control unit, the 21st message will be "Too many fault messages". To see those messages that are not shown, one or more of the first messages must be reset.
- 7 Press "SELECT" to show more information on the fault code. Fault codes are shown numerically here. If the fault is inactive, both the time and date for the fault are shown.  
**MID:** Identification of control unit  
**PID:** Identification of parameters  
**PPID:** Volvo unique Identification of parameters  
**SID:** Identification of components  
**PSID:** Volvo unique Identification of components  
**FMI:** Identification of fault IDs  
To reset the fault code, hold "SELECT" in for 1 second.

## Instrument panel cluster self test

### Indicator lamps test

- 1 Select "Tell-tales test, LEDs" with ▲ and ▼.
- 2 Confirm with "SELECT".
- 3 The tell-tales light up for approx. 5 seconds.
- 4 Cancel the test with "Esc"

### Gauge test

- 1 Select "Gauge test" with ▲ and ▼.
- 2 Confirm with "SELECT".
- 3 The gauges make a diagnostic sweep. The pointers move back and forth a few times, between the end positions. They should not show

any particular value. This is just a check that they move (e.g. that the drive stages and gauges function).

- 4 Cancel the test with "Esc"

## Display test

- 1 Select "Display test" with ▲ and ▼.
- 2 Confirm with "SELECT".
- 3 The whole display lights up for approx 3 seconds after which it blacks out for 3 seconds. After this a checkered pattern is displayed for 3 seconds. The checkered pattern is then displayed inverted for 3 seconds.
- 4 Cancel the test with "Esc"

## Loudspeaker test

- 1 Select "Loudspeaker test" with ▲ and ▼.
- 2 Confirm with "SELECT".
- 3 The display shows the name of the sound at the same time as the sound is activated for 10 seconds. Using ▲ and ▼ you can switch between the different sounds.
- 4 Cancel the test with "Esc"

## Part number

A list of the truck control units is shown in the menu "Part Number". Both the control unit's hardware and software numbers are shown.

- 1 Select part with ▲ and ▼.
- 2 Confirm with "SELECT".
- 3 Go back with "Esc"

## Vehicle data

### Oil level

The truck has an electronic oil level sensor.

The bar marked min and max shows the engine oil level. The figure in the middle shows how many litres between min and max levels.

The engine oil level is also shown when the key is turned to the ignition position. The level is shown for 5 seconds or until the engine has started and is shown directly after the SRS and welcome message.

In order to show the correct value, the engine must have been turned off for at least 70 minutes. If the engine has not been turned off sufficiently long, the display shows how many minutes remain until a correct value can be shown.

If the oil level is "min" or below "min" a warning symbol is shown.

### Note!

There is no warning for low oil level while driving.

### Note!

The oil level shall lie between "min" and "max". Do not top up before the level approaches "min". Too much oil in the engine can increase oil consumption.

### Load indicator

The display shows indicated pressure on each axle, indicated weight of the truck, indicated weight of the trailer and indicated weight of the load. With bogie and double drive axles the indicated weight on both axles is shown. The values are updated every two seconds.

See the separate driver instruction for more information about the load indicator's function.

### Brake lining, status

Shows the condition of the truck's brake linings.

## Vehicle ID

The truck chassis number and the vehicle number that were entered into the menu "Fleet ID" are displayed here.

## Total value

The total values show the engine's total values to date, logged during the lifetime of the engine control unit.

The values that are saved are

- Total distance
- Total fuel used
- Total engine hours
- Total idle time
- Total PTO hours
- Total engine revolutions

Scroll between values with ▲ and ▼. Return to previous menu with "Esc".

If the transfer should fail, then "No data" is shown when data is missing.

## Trip data

There are 14 different trip values stored.

- Trip distance
- Trip fuel avg
- Trip fuel acc
- Trip overrevolutions
- Trip uneconomy rev's
- Trip fuel uneconomy rev's
- Trip average speed
- Trip overspeed:
- Trip engine hours
- Trip idle time
- Trip idle fuel
- Trip PTO hours
- Trip PTO fuel
- Trip cruise

### **Note!**

In the menu "Trip data" you can find information saved since the last reset. To reset, see "Reset Trip data".

Scroll between values with ▲ and ▼. Return to previous menu with "Esc".

If the transfer should fail, then "No data" is shown when data is missing.

### Reset trip data

Only accessible if correct password is entered.

Reset all information in menu "Trip data". Follow the instructions on the display.

### Password

Certain functions in the display are password protected. There are three passwords for the display. When the vehicle is supplied from the factory the passwords are:

Workshop Password 1: 0000

Owner Password: 1234

Workshop Password 2: 5678

When "Workshop, password 1" is entered, it is possible to reset values (applies to a number of functions).

With the two other passwords the following menus can also be accessed:

- Fleet limit: engine RPM
- Fleet limit: the speed
- Fleet limit: fuel
- Fleet ID

When the key has been in the stop position for more than 60 seconds or the batteries have been disconnected, the password must be entered again in order to access all the functions.

It is possible to remove the password protection for certain functions. This can be carried out by a Volvo workshop.

- 1 Set the first digit with ▲ and ▼
- 2 Step to the next digit using "SELECT"

### Note!

Change password to prevent unauthorized access to menus, see "Change Password".

3 Step backwards with “Esc”

## Service reminder

(optional in certain markets)

A service reminder is used to remind the driver when it is time to leave the vehicle for service. The reminder is shown in the display, first as a forewarning and then as a warning.

The service reminder is activated after a number of kilometres driven.

When the number of driven kilometres is reached the pre-defined value (as is defined by the fleet owner together with a Volvo dealer), the service reminder is activated.

## Forewarning

A forewarning indicates that it is time to book a service with a Volvo dealer. A forewarning is shown in the display when 90% of the predefined number of kilometres driven has been reached.



The forewarning message is active for 30 seconds. The message will continue to be shown each time the key is turned to the starting position, together with a lamp for information messages, until either the service reminder is reset or until a warning message is shown.

By using the display's control unit by the steering wheel, you can reach the sub-menu to see the value that the fleet owner has defined together with the Volvo dealer. In the sub-menu, the following is shown in the display when a forewarning level is reached.



Information message

J3014466

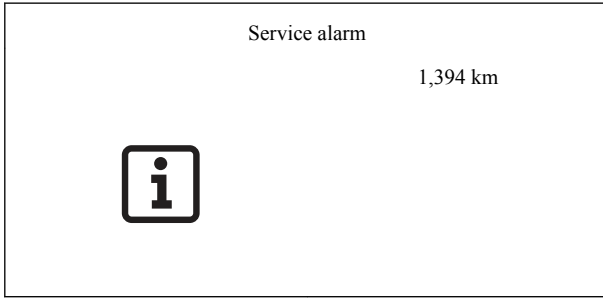

## Warning

A warning indicates that it is time for service. The warning is displayed when 100% of the predefined value is reached.



A warning message is active until the driver has acknowledged the message with the "ESC" button in the display's control unit by the steering wheel. The warning message will continue to be shown each time the key is turned to the starting position, together with the warning message lamp, until the service warning is reset.

By using the display's control lever by the steering wheel, you can access the sub-menu. When the predefined value has been reached, "--" is shown in the sub-menu.



Warning message

J3014465

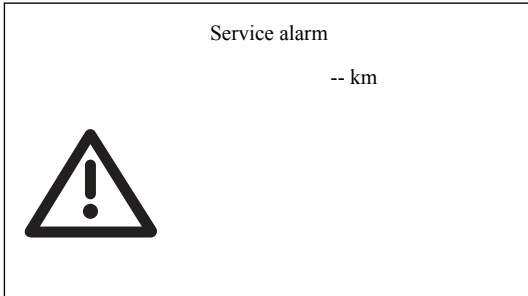

## Resetting the service reminder

Enter the menu structure under Maintenance and Service

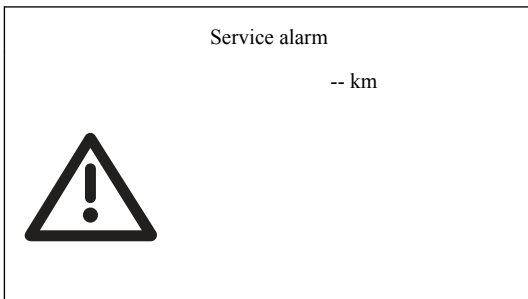

Keep the "SELECT" button pressed in for at least 3 seconds. Enter password, workshop password 2, see the section Entering password. Mark, using ▲ and ▼, if resetting is to be done. Confirm with "SELECT".

The display shows a confirmation that resetting has started.

## Estimated lining wear

One can see at which mileage the brake linings need replacing under menu "Vehicle data" in the vehicle information display. This information can also be read off at a Volvo-workshop.



## Monitoring of the wheel brakes

If the braking effect on a wheel is weaker than on the other wheels, the "CHECK" lamp lights and a symbol is shown on the display. You will feel no difference in the braking power since the other wheels will brake harder instead. However a fault code is stored in the system and a Volvo service station should examine the braking system.



J3014494

Warning symbol for poor braking effect.

## High brake temperature warning

If the brakes start to overheat, the "CHECK" lamp lights and a symbol is shown in the display. The brake pedal must be pressed harder to obtain the same braking power as before.



J5013670

Warning symbol for high brake temperature.

## Resetting fault codes

If the EBS sets a fault code, the fault code cannot be reset in the same way as other fault codes. It must be done in this way instead:

### Conditions:

- Vehicle stationary.
- The pneumatic system is filled, to at least 10 bar pressure.
- The parking brake shall not be set if there is a fault on the trailer modulator.

### Execution:

- 1 Turn off the ignition so that the control unit is reset. Wait at least five seconds. During this time, the brake shall not be applied!
- 2 Switch ignition on.
- 3 Wait at least fifteen seconds. During this time, the vehicle must be stationary without the foot

### Note!

See the information in the instrument display.

brake being applied. The warning lamp is lit, the system limitations are active.

- 4 Apply the footbrake until it is fully depressed.
- 5 Keep the footbrake pedal fully depressed for at least five seconds.
- 6 Release the footbrake until it is fully raised.
- 7 The brake pedal must be fully released for at least five seconds.

**Reset test successful, warning lamp goes out:**

- No fault detected during braking.
- Fault codes disabled.
- Normal brake function.

**Reset test unsuccessful, warning lamp stays lit:**

Reset test incorrectly performed.

- Braking in progress for longer than 25 seconds.
- The vehicle moved during the test.

Test correctly performed, but there is still an active fault in the EBS system.

- Perform the test several more times.

**The ignition must be switched on/off in order to perform a new reset test. See points 1–3 above.**

## Position and content

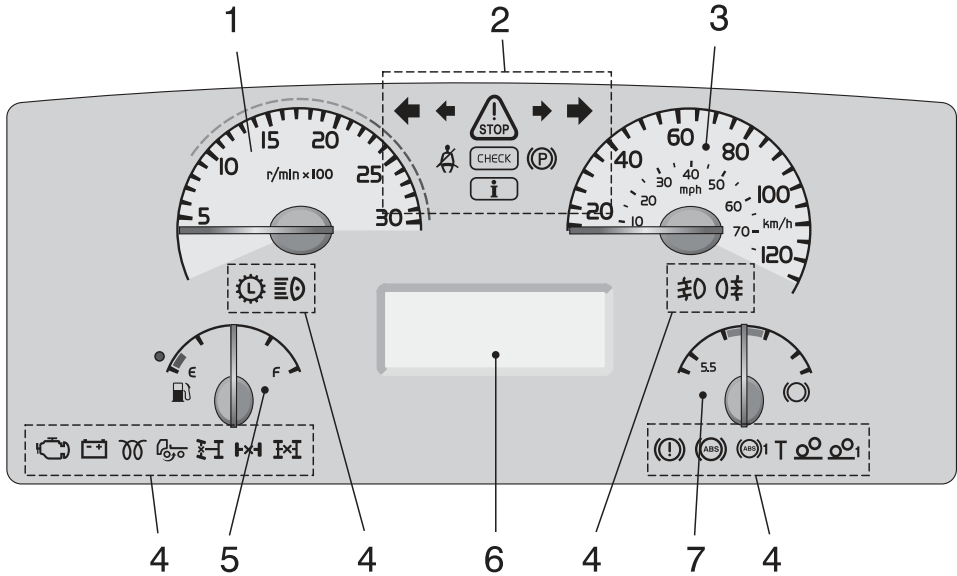

J3018753

- 1 Tachometer
- 2 Control and warning lamps
- 3 Speedometer
- 4 Control and warning lamps
- 5 Fuel gauge
- 6 Display
- 7 Brake pressure gauge

The display, situated in the middle of the instruments, has the job of presenting information to the driver, refer to section "Display" for more information. The info display is operated with the control lever on the right side of the steering wheel, and using this the

driver or workshop can obtain information, see section "Display control stalk" for more information.

## Display

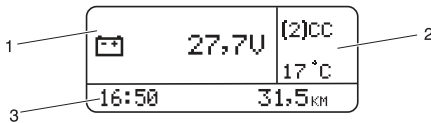

J3018843

The display is located in the middle of the the instrument cluster. You can use the display to see vehicle messages, control certain functions on the truck and see information about the truck, amongst them temperatures, levels and distances.

The display window is divided into three sectors:

- 1 Menu. This is where the menus are displayed, together with automatic alarms, warnings and information messages.
- 2 Status bar. The upper part displays the status symbols. The lower part displays the outdoor temperature.
- 3 Status bar. The clock is displayed on the left. The odometer is displayed on the right.

### Display control stalk

In order to communicate with the display, the control lever on the right hand side of the steering wheel is used. The following commands are available:

- 1 “Esc” is used to return to the previous character and to discontinue a setting/operation.
- 2 “SELECT” confirms a selection or a character.
- 3 “▲” is used for increasing values when setting digits and for browsing in the diagnostics menus.
- 4 “▼” is used for reducing values when setting digits and for browsing in the diagnostics menus.

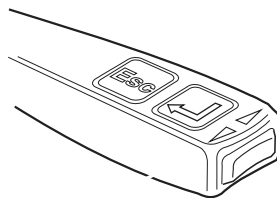

J3008810

### General, about messages

There are three types of messages:

- Information
- Warning
- Stop

Above the info display are three lamps (for information, warning or stop messages) which attract the driver's attention to faults in the vehicle.

### Information messages

When this light comes on a new information message is displayed. The lamp is used to inform the driver.

The lamp lighting does not indicate a fault in the vehicle.



J3014366

## Warning messages

When this symbol lights up, the fault indicated should be checked before driving. If no other warning lamp lights to indicate the fault, contact the workshop. Fault codes are obtained from the diagnostic menu, refer to section “Fault diagnosis”.



J3014365

## Stop message

 <b>Warning!</b>
<p>When this symbol lights up, the vehicle should be stopped immediately and the engine switched off. If the vehicle is not stopped and the engine turned off, there will be serious consequences for the vehicle, driver or load. Contact a workshop. Fault codes are obtained from the diagnostic menu, refer to section “Fault diagnosis”.</p>



J3014364

## Acknowledge messages

The message lamp goes out when ”Esc” is pressed. Both warning and stop messages can be acknowledged. Messages which have been acknowledged but which are active are shown again when the starter key is turned to starting position.

















**Warning message:** Warning messages can be acknowledged with ”Esc”. This warning is















## 84 Information display

acknowledged until the next time the ignition key is turned to the starter position. The warning message and the symbol go out 30 seconds after the engine is started.























**Stop message:** The buzzer is turned off with "Esc", but is active again 10 seconds after the latest button depression. The stop light remains lit the whole time.







### Alarm, warning and information symbols

Symbol	Meaning	Symbol	Meaning
	High temperature, coolant		Crankcase pressure too high
	Low level, coolant		Engine fault
	Low oil pressure, engine oil		Engine speed too high
	Low oil level, engine oil		Low air pressure, gearbox
	High temperature, engine oil		Gearbox fault
	Air intake heating fault		Low level, gearbox oil
	High temperature, inlet manifold		Low oil pressure, gearbox
	Engine temperature too low for engine brake (VEB)		High temperature, gearbox oil



Symbol	Meaning	Symbol	Meaning
	Too high concentration of soot particles or ash in the particulate filter. See section “Particulate filter” for more information.		Parking brake applied
	Air filter clogged. Check that the net in the air intake is not clogged.		Brake pressure low
	Engine is switched off		Clutch running hot
	Cab tilt lock open		Temperature, hydraulic retarder
	The compressor charge is unusually high. The cause could be an air leak. <ul style="list-style-type: none"> <li>• If the symbol is shown together with the information symbol (i), the leak is so large that fuel consumption is increased.</li> <li>• If the symbol is displayed together with the check symbol (CHECK), then the leak is so large that it can cause an unplanned stop if not remedied.</li> </ul>		Risk of moisture in the pneumatic system. There are several causes: <ul style="list-style-type: none"> <li>• Time to replace the desiccant element.</li> <li>• The compressor is being used to much.</li> <li>• Fault with the air system.</li> </ul>
	Fault in trailer EBS function		Leakage from indicated tyre/axle. This warning may also occur after changing tyres. Disable by unscrewing the hose to the tyre pressure sensor on the tyre in question, wait for a minute and then screw on again. (Key in drive position)
	Connected trailer without ABS		High tyre pressure



Symbol	Meaning	Symbol	Meaning
	Poor brake effect on trailer		Low tyre pressure
	Uneven braking effect between tractor and trailer		Baggage door open
	Low pressure in the air suspension system		Door open
	Wheel spin or ABS activated		Door to cargo hold open
	Traction Control Function temporarily disengaged		Airbag
	Trailer disconnected		Low level washer fluid
	Superstructure not in drive position		One or more lamps do not light.
	Air suspension in manual position		Fault in the electrical system causing lamps not to light. Can cause a hardware fault in the electronics.
	Air suspension not in drive position		Warning. Freezing conditions.
	Low pressure or flow in steering servo. The symbol might be displayed when stationary or at low speed without there being a fault.		Fuel filter clogged
	Stop		Low fuel level

Symbol	Meaning	Symbol	Meaning
	Voltage warning		Stability control active
	Battery discharge		Diagram sheet box open or sheet for driver 1 missing. (Only for certain variants)
	Alarm in service position.		ESP (electronic stability program) temporarily disengaged







## Symbols for air suspension

Symbol	Meaning	Action
	The control button is set to manual control or adjustment of ride height.	Select ride height <b>Note!</b> Drive very carefully when the symbol is displayed.
	If the control button is in the centre position the air suspension is in locked position.	Check whether the air suspension is locked: Turn the ignition key to the stop position (0) and then back to the drive position (I). If the symbol remains on the display the air suspension is locked. See section "Air suspension in locked position", page 628.
Axle load distribution 70%	With "optimise traction", the axle load distribution is shown in the display.	None. The message disappears when optimal load distribution has been achieved.
	Truck not in drive position.	Check that the control button is in the drive position and wait until the truck reaches the correct drive height. <b>Note!</b> Drive very carefully when the symbol is displayed. A signal will sound if the speed is too high. If a bellows is punctured, drive, at not more than 30 km/h, to a Volvo workshop, or contact Volvo Action Service.

Symbol	Meaning	Action
CHECK THE AIR SUSPENSION AT THE NEXT STOP	There is an air suspension malfunction.	Check whether the fault is active at the next stop: Turn the ignition key to the stop position (0) and then back to the drive position (I). If the message remains in the display, the fault is active. See section "Air suspension in locked position".

## Status symbols

Status symbols are shown in the lowest row of the display.

Symbol	Meaning	Symbol	Meaning
	Pre-heating active or pre-heating fault	<b>PTO</b>	Power take-off active
	Parking heater timer activated	<b>CC</b>	Cruise control active
	Alarm clock activated	<b>ACC</b>	Adaptive cruise control active
	Message active	<b>(A)</b>	Auxiliary brake position A
	Water in fuel (draining required)	<b>(1)</b>	Auxiliary brake position 1
	Auxiliary brake in operation	<b>(2)</b>	Auxiliary brake position 2
<b>MI</b>	Odometer, miles	<b>(3)</b>	Auxiliary brake position 3
<b>KM</b>	Odometer, kilometres	<b>(B)</b>	Auxiliary brake position B

## Other Symbols

There are even more symbols within different menus that have not been included here. See the description of the menu in question for an explanation.

## Gear position

The menu "Gear position" shows information about engaged gear, lever position, available gears etc.

For further information about "Gearbox", see separate driver instructions "I-shift" and "Powertronic".

## Temperature, outside

The temperature outside the cab.



J3005101

## Engine oil pressure

Oil pressure.



## Temperature, engine oil

Temperature of the engine oil.



J3013611

## Voltmeter/Ammeter

Voltage values less than 20.0 V are presented as LOW if the engine speed is less than 800 rpm for 10 minutes. Voltage values higher than 30.0 V are presented as HIGH.



J3008832

## Fuel consumption

For setting the units, see section “Units”.

- 1 Average fuel consumption:  
The value is presented as a figure and an arrow pointing down, (e.g. 026.) During a time after resetting the display shows “— — —” while average fuel consumption is calculated.
- 2 Instantaneous fuel consumption:  
The value is presented numerically as well as in the form of a bar.



J3014498

### Note!

At idle, no bar is shown and the fuel consumption is displayed in litre/hr (alternatively gallons/hr).

## Resetting, fuel consumption

To reset **all** fuel data, depress “SELECT” for 1 second.

## Leg data

The amount of fuel consumed since the last reset.



J3013617

## Resetting, leg data

To reset **all** fuel data, depress “SELECT” for 1 second.

## Remaining fuel

How far one can drive at the current average consumption



J3014498



J0010376

## AdBlue

How much AdBlue is left in the tank.



J0013296

## Trip meter

Show the distance driven since the last reset.



J0009587

### Note!

The trip values must be reset before each measurement.

## Reset trip meter

To reset leg data, hold "SELECT" depressed for 1 second.

## Average speed

The average speed is calculated as the distance driven divided by the time the engine has been running (since latest reset).



J3013620

### Note!

The values must be reset before each measurement.

## Reset average speeds

To reset leg data, hold "SELECT" depressed for 1 second.

## Driving/rest time

Information about driving and rest times is taken from the digital tachograph.

The symbol is at the far left and the information under it varies depending on the selected activity in the digital tachograph.

The symbol in the centre indicates pause and rest time.

The symbol to the right indicates driving time



## Time and Date

Current time and date. For alternative settings 12h or 24h and date format, see section "Time/date".



J3013618

## Menu structure

- 1 Displays
  - 1.1 Black panel
  - 1.2 Night/Day <sup>1</sup>
  - 1.3 Backlight
  - 1.4 Contrast
- 2 Display settings <sup>2</sup>
  - 2.1 Language
  - 2.2 Units
  - 2.3 Time/Date
- 3 Parking heater timer <sup>2,3</sup>
  - 3.1 Programming
  - 3.2 Reset
- 4 Vehicle settings <sup>2</sup>
  - 4.1 TCS <sup>3</sup>
  - 4.2 DRL <sup>3</sup>
  - 4.3 Draining/Priming
- 5 Diagnosis <sup>2</sup>
  - 5.1 Fault diagnostics
  - 5.2 Part number
  - 5.3 Calibration ID

<sup>1</sup>Alternate between positive and negative display states.

<sup>2</sup>Applies only when stationary.

<sup>3</sup>Option

## Black Panel

When "Black Panel" is active, only the speedometer and tachometer are illuminated (except the coloured field).

The following events light the backlighting:



- a message is activated
- a button is depressed
- the engine speed enters the red zone on the tachometer

## Night/Day

This function is used to switch between yellow text on a black background and black text on a yellow background.

## Backlight

The display lighting follows the rheostat setting (which also controls the other instrument lighting). This menu can be used to alter the display lighting with respect to the lighting of the other instruments.

### Set backlight

- 1 Increase or decrease the backlighting with ▲ and ▼.
- 2 Confirm with "SELECT".
- 3 "Esc" aborts the setting.



J0009588

## Contrast

- 1 Increase or decrease contrast with Δ and □.
- 2 Confirm with "SELECT".
- 3 "Esc" aborts the setting.



J0009588

## Language

- 1 To set the required language press "SELECT".
- 2 Up to three different language alternatives appear in the display. Select the desired language by moving the cursor to the required row with ▲ and ▼. Confirm the choice with "SELECT".

## Units

### Distance

Select if the trip should be shown as km or miles.

- 1 Mark the desired unit with ▲ and ▼.
- 2 Confirm with "SELECT".
- 3 "Esc" aborts the setting.

### Fuel consumption

Select if fuel consumption is shown as km/l, l/100 km, miles per gallon (mpg) with IMP gallons or as miles per gallon (mpg) with US gallons.

- 1 Mark the desired unit with ▲ and ▼.
- 2 Confirm with "SELECT".
- 3 "Esc" aborts the setting.

### Temperature

Select if temperature shall be shown as Celsius (°C) or Fahrenheit (°F).

- 1 Mark the desired unit with ▲ and ▼.
- 2 Confirm with "SELECT".
- 3 "Esc" aborts the setting.

### Pressure

Select if pressure should be shown as psi or bar.

- 1 Mark the desired unit with ▲ and ▼.
- 2 Confirm with "SELECT".
- 3 "Esc" aborts the setting.

## Time/Date

### Time

- 1 Mark the time format with ▲ and ▼.
- 2 Confirm with "SELECT".

- 3 "Esc" aborts the setting.

In the AM/PM-format the time only goes to 12 and then starts again from 1. AM is morning and PM is afternoon.

## Date

Select if the date is to be shown as year, month, day (yymmdd), or day, month, year (ddmmyy) or as month, day, year (mmdyy).

- 1 Select the date format with ▲ and ▼.
- 2 Confirm with "SELECT".
- 3 "Esc" aborts the setting.

## Program

If the timer already has a time set, it will be shown.

- 1 Press "SELECT".
- 2 Move the cursor to "Programming" using ▲ and ▼.
- 3 Confirm with "SELECT".
- 4 Set the start date with ▲ and ▼  
Current date is default.
- 5 Confirm with "SELECT".
- 6 Set the start time with ▲ and ▼
- 7 Confirm with "SELECT".
- 8 Set duration with ▲ and ▼  
The time is changed in 10 minute intervals. The longest time that can be set is 2 hours.
- 9 Confirm with "SELECT".
- 10 The set time and date are shown.
- 11 Confirm with "SELECT".

## Reset

- 1 Press "SELECT".
- 2 Move the cursor to "Reset" using ▲ and ▼.

- 3 Confirm with "SELECT".

## Traction Control

- 1 Select "On" or "Off" with ▲ and ▼.
- 2 Confirm with "SELECT".
- 3 "Esc" aborts the setting.



J3014424

If traction control is turned off, a warning symbol is shown.

## Day Running Light

Day Running Lights can be shut off in this menu. This means that if the Day Running Lights are "Off", so the dip beam must be turned on and off with the lighting knob on the panel.

- 1 Select "On" or "Off" with ▲ and ▼.
- 2 Confirm with "SELECT".
- 3 "Esc" aborts the setting.

## Draining/priming

Draining/priming of the fuel system is done via this menu, when required.

Depending on whether it is draining or priming that is required, the display will show different messages.

## Fault diagnostics

A list of the truck control units is shown in the menu "Fault diagnostics".

Switch between control units using ▲ and ▼.

"SELECT" confirms choice of control unit. To cancel, press "Esc".

- 1 During the time that the selected control unit is polling, the display indicates that data transfer is taking place.

- 2 If the selected control unit has no faults "No faults" is displayed.  
Press "Esc" to return to the previous menu.
- 3 If the selected control unit does not reply within 5 seconds the following is shown "Operation failed" in the display.  
Press "Esc" and try once more, see point 1.  
Contact a workshop if necessary.
- 4 If the selected control unit has a fault code or fault codes, it displays
  - 1 Which control unit it applies to
  - 2 Which parameter or component is faulty
  - 3 Which type of fault it is
  - 4 If the fault is active or inactive
  - 5 How many times the fault has been registered since the last reset
- 5 If there are several fault codes or fault messages for the same control unit, you can scroll through the fault codes with ▲ and ▼. "Reset all" is shown last in the list. This resetting only clears the fault codes for the selected control unit.
- 6 If there are more than 20 fault codes/fault messages for the selected control unit, the 21st message will be "Too many fault messages". To see those messages that are not shown, one or more of the first messages must be reset.
- 7 Press "SELECT" to show more information on the fault code. Fault codes are shown numerically here. If the fault is inactive, both the time and date for the fault are shown.  
**MID:** Identification of control unit  
**PID:** Identification of parameters  
**PPID:** Volvo unique Identification of parameters  
**SID:** Identification of components  
**PSID:** Volvo unique Identification of components  
**FMI:** Identification of fault IDs  
To reset the fault code, hold "SELECT" in for 1 second.

## Part number

A list of the truck control units is shown in the menu "Part Number".

- 1 Select part with ▲ and ▼.
- 2 Confirm with "SELECT".
- 3 Go back with "Esc"

## Calibration ID

A list of the truck control units is shown in the "Calibration ID" menu.

- 1 Select part with ▲ and ▼.
- 2 Confirm with "SELECT".
- 3 Go back with "Esc"

## Service reminder

(optional in certain markets)

A service reminder is used to remind the driver when it is time to leave the vehicle for service. The reminder is shown in the display, first as a forewarning and then as a warning.

The service reminder is activated after a number of kilometres driven.

When the number of driven kilometres is reached the pre-defined value (as is defined by the fleet owner together with a Volvo dealer), the service reminder is activated.

### Forewarning

A forewarning indicates that it is time to book a service with a Volvo dealer. A forewarning is shown in the display when 90% of the predefined number of kilometres driven has been reached.

# 100 Information display

---



Upcoming maintenance

The forewarning message is active for 30 seconds. The message will continue to be shown each time the key is turned to the starting position, together with a lamp for information messages, until either the service reminder is reset or until a warning message is shown.

By using the display's control unit by the steering wheel, you can reach the sub-menu to see the value that the fleet owner has defined together with the Volvo dealer. In the sub-menu, the following is shown in the display when a forewarning level is reached.



J3014466

Information message

Service alarm

1,394 km



## Warning

A warning indicates that it is time for service. The warning is displayed when 100% of the predefined value is reached.

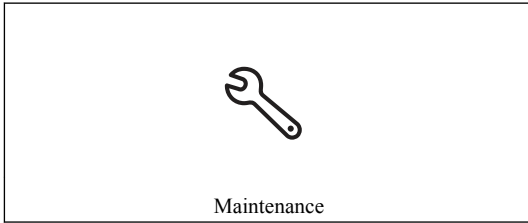

A warning message is active until the driver has acknowledged the message with the “ESC” button in the display's control unit by the steering wheel. The warning message will continue to be shown each time the key is turned to the starting position, together with the warning message lamp, until the service warning is reset.

By using the display's control lever by the steering wheel, you can access the sub-menu. When the pre-defined value has been reached, "--" is shown in the sub-menu.



J3014465

Warning message

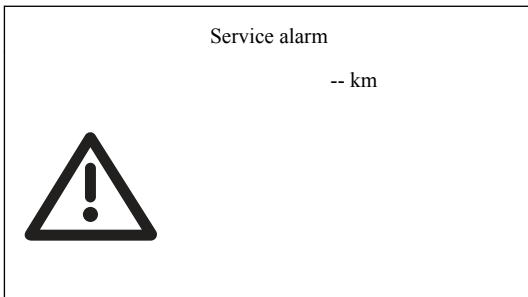

## Resetting the service reminder

Enter the menu structure under Maintenance and Service



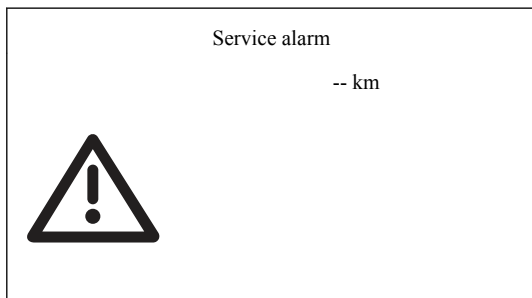

Keep the "SELECT" button pressed in for at least 3 seconds. Enter password, workshop password 2, see the section Entering password. Mark, using ▲ and ▼, if resetting is to be done. Confirm with "SELECT".

The display shows a confirmation that resetting has started.

## Numeric language, general

The instructions describe how the numeric language is constructed and how it functions. Only the most important menus and messages are described.

## Display control stalk

Manual communication with the displays is achieved with the control stalk on the right-hand side of the steering wheel. The following commands are available:

- 1 "Esc" is used to return to the previous menu and to discontinue a setting/operation.
- 2 "SELECT" confirms a selection or a character
- 3 "▲" moves the cursor up and is used when setting numbers/letters
- 4 "▼" moves the cursor down and is used when setting numbers/letters

## Text strings

Numbers between the symbols "<<" and ">>" symbolize a text string. For information on what the numerical text means, see section "Menus" or "Numerical translation table".

## Stop message

### Red stop lamp + stop symbol

If the red stop lamp and the stop symbol are displayed the vehicle should be stopped immediately and the engine switched off. The associated numerical text should be read in order to establish where the fault lies. For information on what the numerical text means, see section "Menus" or "Numerical translation table".



J3014364



J3013624

A warning will sound if the engine is running. It can be acknowledged by pressing Esc, but it starts again after 10 seconds. For more information about the message, see "Driver instructions Display, graphical".

 <b>Warning!</b>
When this lamp lights, the vehicle must be stopped immediately and the engine switched off.

### The information lamp CHECK + text

When the information lamp CHECK lights up, the fault should be checked at the next stop. The associated numerical text is shown in the display. A result of measurement is also shown for some symbols. For information on what the numerical text means, see section "Menus" or "Numerical translation table".



J3014365

## Change language

The numerical language is a choice and can be shown as one of three languages in the display. The language can be changed in the menu "Display settings".

## Language

**MENU:** Display setting, language

The language setting remains even after the ignition has been switched off.

- 1 Select "Language" with "▲/▼" and press "SELECT"
- 2 Up to three languages can be displayed. Mark "Numerical" with "▲/▼" and press "SELECT". Press "Esc" to discontinue the setting and return to the main menu.

## Menus, general

The numerical language is hierarchically constructed and follows the same structure as in "Driver instruction Display, graphical". In those menus which have text, the text is marked with numbers. The menu explanation gives all menu headings and associated text strings.

## Password-protected menus

For information about passwords, see "Driver instruction Display, graphical".

<sup>1</sup> Password-protected menu

## Menus available when driving

### Menu 1

---

<<100>> = Gauges

---

---

Temperature, outside

---

Temperature, engine oil

---

Temperature, gearbox

---

Voltmeter/Ammeter

---

Gear position

---

Pressure, primary tank

---

## Menu 2

---

<<101>> = **Fuel Data**

---

### **Fuel consumption**

---

Resetting, Fuel Data

---

<<400>> = Reset ALL fuel data? Hold SELECT for 1 second.

---

### **Leg data**

---

Resetting, Fuel Data

---

<<400>> = Reset ALL fuel data? Hold SELECT for 1 second.

---

### **Remaining fuel**

---

## Menu 3

---

<<102>> = **Time/Distance**

---

### **Trip meter**

---

Reset trip meter

---

<<403>> = Reset? Hold SELECT for 1 second.

---

### **Average speed**

---

Reset average speeds

---

<<403>> = Reset? Hold SELECT for 1 second.

---

### **Estimated time of arrival**

---

# 106 Information display

---

---

Inputting distance to destination

---

<<405>> = Set distance:

---

## **Time and Date**

---

Setting, time and date

---

## **Alarm clock**

---

Setting, Alarm clock

---

<<301>> = ON

---

<<302>> = OFF

---

<<303>> = SET

---

## **Menu 4**

---

<<103>> = **Display**

---

<<304>> = **Black Panel**

---

<<306>> = **Backlight**

---

Set backlight

---

<<307>> = **Set Favourite display**

---

<<308>> = **Night/Day**

---

## **Menu 5**

---

<<104>> = **Vehicle Messages**

---

<<309>> = No messages

---

MID 128 = Engine system

---

MID 136 = Brake system

---

MID 130 = Gearbox system

---

MID 223 = Gear selector system

---

MID 222 = Retarder system

---

---

MID 144 = Vehicle system

---

MID 140 = Info display system

---

MID 150 = Air suspension system

---

MID 249 = Bodybuilder system

---

MID 146 = Climate system

---

MID 232 = Airbag system

---

MID 219 = Adaptive cruise control

---

MID 216 = Light control system

---

MID 231 = Telephone

---

MID 163 = Immobiliser

---

MID 179 = FMS Gateway

---

MID 203 = Transp info system

---

MID 250 = Steering Wheel

---

MID 166 = Tyre pressure

---

<<1000>> = No data

---

<<1001>> = HIGH

---

<<1002>> = TOO HIGH

---

<<1003>> = Freezing conditions

---

<<1004>> = Discharge

---

<<1005>> = You need to fill up with fuel.

---

<<1007>> = LOW

---

<<1008>> = TOO LOW

---

<<1009>> = Check

---

<<1010>> = Check at next stop

---

<<1011>> = Stop failure

---

<<1012>> = Check datalink

---

<<1013>> = Check datalink broken

---

# 108 Information display

---

---

<<1014>> = Low pressure

---

## Menu 6

---

<<1040>> = Tyre pressure

---

<<1041>> = Truck

---

<<1042>> = Trailer 1

---

<<1043>> = Trailer 2

---

<<1044>> = Trailer 3

---

<<1045>> = Trailer 4

---

<<1046>> = Trailer 5

---

## Menu 7

---

<<105>> = Reset

---

<<406>> = Reset ALL data? Hold SELECT for 1 second.

---

## Menus with stationary vehicle

### Menu 8

---

<<107>> = P-heater timer

---

<<212>> = Programming

---

<<356>> = Set startdate

---

<<418>> = Set starttime

---

<<502>> = Set duration

---

<<213>> = Reset

---

<<214>> = No time set

---

## Menu 9

---

### <<108>> = Display Settings

---

#### <<200>> = Language

---

Numerical = Numerical language

---

Swedish

---

English

---

#### <<201>> = Units

---

##### <<310>> = Distance

---

km

---

miles

---

##### <<311>> = Fuel Consumption

---

km/L

---

L/100km

---

mpg (IMP gallons)

---

mpg (US gallons)

---

##### <<312>> = Temperature

---

°C

---

°F

---

##### <<359>> = Pressure

---

psi

---

bar

---

#### <<202>> = Time/Date

---

##### <<313>> = 24h or AM/PM Clock Format

---

<<409>> = 24 h

---

<<410>> = AM/PM

---

##### <<314>> = Date Format

---

<<411>> = yymmdd

---



# 110 Information display

---

---

<<412>> = ddmmyy

---

<<413>> = mmddyy

---

## <<203>> = Display Light

---

<<315>> = Contrast

---

<<316>> = Backlight

---

<<317>> = Day Mode

---

<<1023>> = Disabled

---

<<1024>> = Enabled

---

## <<204>> = Change password<sup>1</sup>

---

<<227>> = To see more menus, give password

---

<<319>> = Workshop password 2

---

<<318>> = Owner password

---

<<320>> = Workshop password 1

---

<<414>> = Enter new password:

---

## Menu 10

---

### <<109>> = Vehicle Settings

---

#### <<205>> = Traction Control

---

<<301>> = On

---

<<302>> = Off

---

#### <<206>> = Fleet Limits

---

<<321>> = RPM (max)<sup>1</sup>

---

<<415>> = Present limit:

---

<<416>> = Set new value:

---

rpm

---

<<1015>> = Operation complete.

---

<<1016>> = Operation failed.

---

<<322>> = Speed (max)<sup>1</sup>

<<415>> = Present limit:

<<416>> = Set new value:

km/h, mph

<<1015>> = Operation complete.

<<1016>> = Operation failed.

<<323>> = Fuel (target)<sup>1</sup>

<<415>> = Present limit:

<<416>> = Set new value:

l/100 km, mpg

<<1015>> = Operation complete.

<<1016>> = Operation failed.

---

<<207>> = **Ammeter sensor calibration**

---

<<417>> = Switch off all current consumers, then turn ignition off.

<<500>> = Calibrating, please wait

<<501>> = Sensor component changed. Switch ignition on.

---

<<208>> = **Fleet ID<sup>1</sup>**

---

<<324>> = Fleet ID:

<<325>> = Enter new Fleet ID:

<<1015>> = Operation complete.

<<1016>> = Operation failed.

---

<<211>> = **Daytime running lights**

---

<<301>> = On

<<302>> = Off

---

<<284>> = **Draining/priming**

---

<<1048>> = **Set wheel ID**

---

<<1047>> = **Set reference pressure**

---

# 112 Information display

---

## Menu 11

---

<<110>> = Diagnostics

---

<<215>> = Fault Diagnostics

---

MID 128 = Engine system

---

MID 136 = Brake system

---

MID 130 = Gearbox system

---

MID 223 = Gear selector system

---

MID 222 = Retarder system

---

MID 144 = Vehicle system

---

MID 140 = Info display system

---

MID 150 = Air suspension system

---

MID 249 = Bodybuilder system

---

MID 184 = Rear axle steering

---

MID 214 = Burglar alarm system

---

MID 146 = Climate system

---

MID 232 = Airbag system

---

MID 219 = Adaptive cruise control

---

MID 216 = Light control system

---

MID 231 = Telephone

---

MID 219 = FMS Gateway

---

MID 163 = Immobiliser

---

MID 203 = Transp info system

---

MID 220 = Tachograph

---

MID 166 = Tyre pressure system

---

<<1017>> = Data transfer in progress, please wait.

---

<<419>> = No errors

---

<<1016>> = Operation failed

---

---

<<420>> = Inactive

---

<<421>> = Active

---

<<423>> = More info? Hold SELECT

---

<<422>> = Number of events:

---

<<503>> = First

---

<<504>> = Last

---

AM

---

PM

---

<<505>> = Reset? Hold SELECT for 1s

---

<<424>> = Reset all faults of this MID? Press SELECT i 1s.

---

**<<216>> = Cluster Selftest**

---

<<326>> = Indicator light test

---

<<327>> = Gauge test

---

<<328>> = Display test

---

<<329>> = Loudspeaker test

---

**<<217>> = Part Number**

---

MID 128 = Engine system

---

MID 136 = Brake system

---

MID 130 = Gearbox system

---

MID 223 = Gear selector system

---

MID 222 = Retarder system

---

MID 144 = Vehicle system

---

MID 140 = Info display system

---

MID 150 = Air suspension system

---

MID 249 = Bodybuilder system

---

MID 184 = Rear axle steering

---

MID 214 = Burglar alarm system

---

# 114 Information display

---

---

MID 146 = Climate system

---

MID 232 = Airbag system

---

MID 219 = Adaptive cruise control

---

MID 216 = Light control system

---

MID 231 = Telephone

---

MID 179 = FMS Gateway

---

MID 163 = Immobiliser

---

MID 203 = Transp info system

---

MID 220 = Digital tachograph

---

MID 166 = Tyre pressure system

---

<<1017>> = Data transfer in progress, please wait.

---

<<430>> = Hardware number:

---

<<431>> = Software number:

---

<<1018>> = No data

---

## Menu 12

---

<<111>> = **Vehicle Data**

---

<<221>> = **Oil level**

---

<<331>> = min<

---

<<332>> = >max

---

<<330>> = Not available. X min left.

---

<<222>> = **Load indicator**

---

<<228>> = **Brake lining, status**

---

## Menu 13

---

<<112>> = **Data log**

---

---

## <<223>> = Vehicle number

---

<<1017>> = Data transfer in progress, please wait

---

<<333>> = Fleet ID:

---

<<334>> = Chassis number:

---

<<1018>> = No data

---

## <<224>> = Total data

---

<<335>> = Total distance:

---

<<336>> = Total fuel used:

---

<<337>> = Total engine hours:

---

<<338>> = Total idle time:

---

<<339>> = Total PTO hours:

---

<<340>> = Total engine revolutions:

---

## <<225>> = Trip data

---

<<341>> = Trip distance:

---

<<342>> = Trip fuel avg:

---

<<343>> = Trip fuel acc:

---

<<344>> = Trip overspeed:

---

<<345>> = Trip uneconomy rev's:

---

<<346>> = Trip fuel uneconomy rev's:

---

<<347>> = Trip average speed:

---

<<348>> = Trip overrev's:

---

<<349>> = Trip engine hours:

---

<<350>> = Trip idle time:

---

<<351>> = Trip idle fuel:

---

<<352>> = Trip PTO hours:

---

<<353>> = Trip PTO fuel:

---

<<354>> = Trip cruise:

---

# 116 Information display

---

<<226>> = Reset Trip data<sup>1</sup>

<<433>> = Reset all trip data? Hold SELECT for 1 second.

<<1017>> = Data transfer in progress, please wait

<<1015>> = Operation complete.

<<1016>> = Operation failed

---

## Menu 14

---

<<113>> = Password

---

**Enter password**

<<227>> = Enter password for more menus:<sup>1</sup>

## Numerical translation table

In order to see quickly what a number means, all numbers are presented here in numerical order with translation.

<<100>> till <<113>>

Number	Meaning
100	Gauges
101	Fuel Data
102	Time/Distance
103	Displays
104	Vehicle Messages
105	Reset
107	P-Heater Timer
108	Display settings
109	Vehicle settings

Number	Meaning
110	Diagnostics
111	Vehicle data
112	Data log
113	Password

## <<200>> to <<284>>

Number	Meaning
200	Language
201	Units
202	Time/Date
203	Display lighting
204	Change password
205	Traction Control
206	Fleet limits
207	Ammeter sensor calibration
208	Fleet ID
209	Fog light
210	Spot light
211	Day Running Light
212	Programming
213	Reset
214	No time programmed
215	Fault Diagnosis
216	Instrument panel cluster self test
217	Part Number
218	General question



# 118 Information display

---

Number	Meaning
219	Other systems
220	Reset All
221	Oil level
222	Load indicator
223	Vehicle ID
224	Totals data
225	Trip data
226	Reset trip data
227	For more menus give password:
284	Draining/priming

## <<300>> to <<358>>

Number	Meaning
300	
301	On
302	Off
303	New time
304	Black Panel
305	Favourite Display
306	Backlight
307	Favourite Display, setting
308	Night/Day
309	No messages
310	Distance
311	Fuel consumption
312	Temperature

Number	Meaning
313	24h or AM/PM
314	Date display
315	Contrast
316	Backlight
317	Night Mode
318	Owner Password
319	Workshop Password 2
320	Workshop Password 1
321	RPM Limit (max)
322	Speed Limit (max)
323	Fuel Target
324	Fleet ID
325	Set new Fleet ID
326	Control lamp test
327	Gauge test
328	Display test
329	Loudspeaker test
330	Not available. X min left.
331	min<
332	>max
333	Fleet ID:
334	Chassis number:
335	Total distance:
336	Total fuel used:
337	Total engine hours:
338	Total idle time:

# 120 Information display

---

Number	Meaning
339	Total PTO hours:
340	Total engine revolutions:
341	Trip distance:
342	Trip fuel avg:
343	Trip fuel acc:
344	Trip overrevolutions:
345	Trip uneconomy rev's:
346	Trip fuel uneconomy rev's:
347	Trip average speed:
348	Trip overrev's:
349	Trip engine hours:
350	Trip idle time:
351	Trip idle fuel
352	Trip PTO hours:
353	Trip PTO fuel:
354	Trip cruise:
355	Wrong password.
356	Set startdate
357	Draining/priming requested
358	Draining/priming not allowed

<<400>> till <<434>>

Number	Meaning
400	To reset ALL Fuel Data? Hold SELECT for 1 second
403	Reset? Hold SELECT for 1 second.
405	Set distance:

Number	Meaning
406	Reset all data? Hold SELECT for 1 second.
409	24h
410	AM/PM
411	yymmdd
412	ddmmyy
413	mmddyy
414	Enter new password:
415	Present limit:
416	Set new value:
417	Switch off all current consumers, then turn ignition off
418	Set start time:
419	No faults
420	Inactive
421	Active
422	Number of events:
423	More info? Hold SELECT
424	Reset all faults of this MID? Hold SELECT for 1 second.
425	Reset all faults? Hold SELECT for 1 second.
426	Alarm
427	Alarm clock
428	Warning
429	Flashers
430	Hardware number:
431	Software number:
432	Set overspeed
433	Reset all trip data? Hold SELECT for 1 second.

## 122 Information display

---

Number	Meaning
434	No other systems available

### <<500>> till <<506>>

Number	Meaning
500	Calibration in progress, please wait
501	Sensor comp. changed. Turn on ignition
502	Set duration:
503	First:
504	Last:
505	Reset? Hold SELECT for 1 second.
506	Too many fault messages

### <<1000>> to <<1096>>

Number	Meaning
1000	No data
1001	High
1002	Too high
1003	Slippery road surface
1004	Discharge
1005	You need to fill up with fuel
1007	Low
1008	TOO LOW
1009	Check
1010	Check at next stop
1011	Stop. Fault.

Number	Meaning
1012	Check datalink
1013	Check datalink broken
1014	Low pressure
1015	Operation complete
1016	Operation failed.
1017	Data transfer in progress, please wait.
1018	No data
1019	Welcome
1020	Have a safe trip
1021	Wrong password
1022	ACC, radar obscured
1023	Inactive
1024	Active
1025	ACC radar warming up
1026	ACC datalink problem
1027	Service of brake linings at:
1028	Brake linings are new.
1029	Brake linings need service.
1030	Disabling idle
1031	Disabling idle, cancelled
1032	Disabling of vehicle started
1033	Vehicle disabled
1034	Trailer, door locked
1035	Trailer, door unlocked
1036	Load, safety system enabled
1037	Load, safety system disabled

# 124 Information display

---

Number	Meaning
1038	Calibration:
1039	Too high vehicle speed. Disable PTO before proceeding
1040	Tyre pressure
1041	Truck
1042	Trailer 1
1043	Trailer 2
1044	Trailer 3
1045	Trailer 4
1046	Trailer 5
1047	Set reference pressure
1048	Set wheel ID
1049	Enter new settings
1050	Select axle number
1051	Current value
1052	New value
1053	Set wheel ID
1054	Enter axle and wheel
1055	Current ID
1056	New ID
1057	No data
1058	Starter motor, overheating alarm
1059	Starter motor, gearbox not in neutral
1060	Starter motor, gear wheel sync.
1061	Start not possible, PTO enabled
1062	Stabilization, ACC sensor
1063	Reversing light trailer

Number	Meaning
1064	Fog lights front
1065	Fog lights rear
1066	Spotlight
1067	Reversing light
1068	Brake lights
1069	Brake lights trailer
1070	Direction indicators, front
1071	Direction indicators, rear
1072	Direction indicators, trailer
1073	Parking lights
1074	Parking lights trailer
1075	Snow plough light
1076	Check fuses
1077	Reduced lighting
1078	Brake light, reduced
1079	Main beam
1080	Dip beam
1081	No data, TPM
1082	Interior lighting
1085	Wait with start
1088	Select a lower gear
1089	Test SW installed in
1090	Reduced EGR system
1091	High pressure in diesel particulate filter
1092	Reduce charge pressure
1093	Reduce charge temp



# 126 Information display

---

Number	Meaning
1094	Vehicle safety mode
1096	LDWS disabled. Clean windscreen

## MID 128 till MID 250

Number	Meaning
MID 128	Engine system
MID 130	Gearbox system
MID 136	Brake system
MID 140	Info display system
MID 144	Vehicle system
MID 146	Climate system
MID 150	Air suspension system
MID 163	Immobilizer
MID 166	Tyre pressure system
MID 179	FMS Gateway
MID 184	Rear axle steering
MID 203	Transp. info system
MID 214	Burglar alarm system
MID 216	Lighting system
MID 219	Adaptive cruise control
MID 222	Retarder system
MID 223	Gear selector system
MID 231	Telephone
MID 232	Airbag system
MID 249	Body builder system
MID 250	Steering wheel functions

## Driving hints

### Drive economically

The driver is the most important link in the chain for obtaining the best total economy.

- 1 **Warm up the engine as quickly as possible.** A warm engine and transmission use less fuel than if they are cold (and also wear less).
- 2 **Use the accelerator sensibly and change gears correctly.** Jerky driving and incorrect use of the gearbox give considerably higher fuel consumption.
- 3 **Do not pump the accelerator.** this increases fuel consumption without increasing speed.
- 4 **Use as high a gear as possible** when the required speed has been attained. Keep the revolutions within the lower half of the green area.
- 5 **Cruise control.** Correctly used in good conditions, the cruise control saves fuel. Excessive use of the cruise control in hilly country can increase fuel consumption, however.
- 6 **High speeds use a lot of fuel,** partly because air drag increases sharply as speed rises. Strong side and head winds increase fuel consumption further.
- 7 **Drive with the engine speed low!** Change down late. Use the maximum engine power on upgrades and allow the engine speed to decrease to the lowest part of the green area before changing down. It is especially important to let the D16 engine work at low rpm, since it has very high torque at low engine speeds. Let the engine pull, it can manage.
- 8 **When you drive with a light load** , excessive gear changing increases fuel consumption.
- 9 **Use good roads!** If possible, avoid poor roads and roads with many hills. Plan your driving carefully. Do not drive so that the energy used for

acceleration is wasted by braking again. Use down hill sections by completely releasing the accelerator. Use the momentum of the vehicle when road conditions allow you to do so.

- 10 **Engine braking.** On gentle downgrades, the engine brake could brake too much and thus give an unwanted effect. To obtain the best fuel consumption, such "unnecessary" braking should be avoided. Please note that there is a middle position on the accelerator, which neither gives engine power nor engine braking.
- 11 **Choose tyres carefully.** Radial tyres have lower rolling resistance. The correct tyre pressure reduces friction and wears the tyres less.
- 12 **Check the front wheel alignment regularly** and axle angles on both the tractor and the trailer. The correct values always give lower rolling resistance and lower fuel consumption.
- 13 **Do not use a higher canopy than necessary.** Always tension the canopy and tarpaulins tightly. Also remember that advertising signs, roof racks etc. give higher fuel consumption.
- 14 **Volvo's spoiler package gives lower fuel consumption if it is correctly adjusted.**
- 15 **Correct maintenance keeps the truck in good trim, which keeps fuel consumption down.**

## Some advice for driving

- 1 Make a check after starting, and occasionally when driving, that the instruments show normal values. If a warning lamp lights up when driving, stop and check the reason.
- 2 Starting **always** start in 1st gear or crawler gear with as low engine speed as possible (700–800 rpm).
- 3 **Never race a cold engine!** Avoid long periods of idling.
- 4 **Never cover the radiator!** Check the coolant level regularly and always use the correct coolant. Also check the hoses and belt tension.

## Note!

It is not permitted to shift between HIGH and LOW range while reversing. First shift to HIGH or LOW range, then engage reverse.

Do not drive with a leaky cooling or heating system.

- 5 **Never drive away until the brake system warning lamps have gone out.** Do not forget to release the parking brake.
- 6 Try not to turn when the front wheels are impeded by a curb or other object. The power steering and the tyres can be damaged.
- 7 **Do not rest your foot on the clutch pedal.** Do not slip the clutch unnecessarily. Using a too high gear can cause clutch wear.
- 8 **Do not change gear when the power take-off is engaged.** (Does not apply to clutch-independent power take-offs.)
- 9 The reverse gear is unsynchronised. Shift to LOW range before engaging reverse. In good driving conditions it is possible to reverse with HIGH range engaged.
- 10 **Use the engine brake when decending hills and during gentle braking.** Avoid having the engine brake constantly applied on slippery roads.
- 11 **Use the differential lock on slippery roads.**
- 12 **Let the engine idle for at least 1 minute after hard driving, before you switch it off** This avoids heat stress in the engine and involuntary coolant loss.
- 13 Check the function of the air drier by draining the primary tank or one of the circuit tanks every week.
- 14 Always use the correct fuel and the correct oil.
- 15 Close the hatches in the rear shelf before driving off.
- 16 The lid on the tachograph should always be closed.

**Warning!**

Do not turn corners on firm roads with the differential lock engaged.

## Driving hints for trucks with air suspension

If the vehicle gets stuck on a slippery surface, the load distribution between the drive axle and the bogie axle can be altered to improve traction.

### Note!

Take care when using snow chains on the drive axle's inner wheels. They can damage the air suspension.



### Warning!

Turn off the electronic air suspension system when using support legs, a plough without floating position, or other equipment that effects the truck's height above the road. On trucks with equipment that effects the truck's height above the road a special switch can be fitted to shut off the automatic height control, mounted by a Volvo workshop.

## Hill start aid

- 1 Keep the vehicle stationary with the footbrake
- 2 Depress the clutch
- 3 Engage a suitable starting gear
- 4 Press the switch.  
The function is activated and the lamp in the switch lights.
- 5 Release the footbrake  
The vehicle is kept stationary automatically. The symbol in the display lights as long as the vehicle is kept braked
- 6 Release the clutch
- 7 Start to accelerate



J5013669

Symbol on the switch and display

### Note!

The automatic system releases the brakes when the clutch is released.

The automatic system releases the brakes when the clutch is released, or when the engine torque is sufficiently great.

Deactivate the function by pressing the button again. The function is always deactivated when the starter key is turned to the 0-position.

Only use the function on uphill inclines.

- 1 Keep the vehicle stationary with the footbrake.
- 2 Press the switch.  
The function is activated and the lamp in the switch lights.
- 3 Release the footbrake.  
The vehicle automatically stays still for a short time.  
The symbol in the display lights as long as the vehicle is kept braked.
- 4 Start to accelerate



J5013669

Symbol on the switch and display

The automatic system releases the brakes after a short time, or when the engine torque is sufficiently great.

Deactivate the function by pressing the button again. When the engine is started the function is always disengaged.

Only use the function on uphill inclines.

## Reversing camera

### Turn on the camera

Engage reverse gear

or

Press the button

(In cold weather there may be a short delay before a good picture is obtained.)



J0010217



## Caution!

The ring around the camera lens cannot be unscrewed. Opening the camera is not permitted as it could become damaged.

### Change backlighting

The backlighting on the display is altered with the same control (4) used to alter the other instrument's lighting.

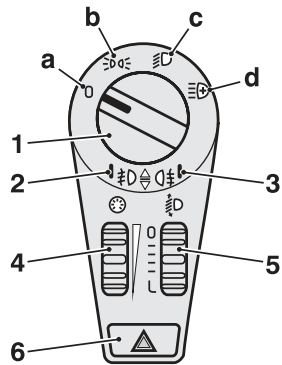

J0010330

### Turn off camera

Disengage reverse (There may be a short delay before the picture turns off.)

or

Press the button



J0010217



## Caution!

The ring around the camera lens cannot be unscrewed. Opening the camera is not permitted as it could become damaged.

## Reversing Warner

The Reversing Warning is two-tone.

- Engage reverse gear once for the high tone.
- Disengage reverse gear and then re-engage it within 7 seconds for the low tone.

## Traction Control System (TCS)

With Traction Control System (TCS), better stability and driveability is achieved. TCS automatically reduces wheel spin by reducing the engine's driving torque. At speeds below 40 km/h the TCS also functions as an automatic differential brake and brakes the wheel that is spinning.

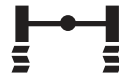

J3014400

The symbol in the display when TCS is active.

### TCS functions

The normal mode is that the TCS is active when the truck is started. The indication lamp in the switch is not on. Engage terrain TCS in difficult driving conditions such as in sand, gravel or snow. Below is a flow for how the button is used in relation to the functions, TCS, terrain-TCS and TCS disengaged.

- Engage terrain-TCS by a short press on the switch. The indication lamp in the switch lights.
- Disengage TCS completely by holding in the switch for a short time. The indication lamp in the switch flashes.

Return to the normal mode (TCS) by pressing the switch. The indication lamp in the switch is out.

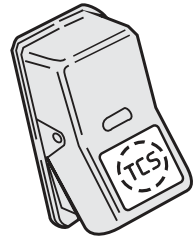

J0008525

The switch is spring-loaded. 3 different functions of the TCS can be obtained.



J3014424

The symbol is shown when TCS is disengaged.



## Note!

Do not use terrain-TCS during normal driving.

## Switching off the TCS

When testing on a roller bench or when towing with an axle raised, the TCS must be switched off.

Use the display to switch off the TCS. The vehicle must be stationary.

- 1 Step to the “Settings” menu (3 and 4)
- 2 Press “Select” (2)
- 3 Step to the “Traction Control” menu (3 and 4)
- 4 Press “Select” (2)
- 5 Step to the “Off” menu (3 and 4)
- 6 Press “Select” (2)

The next time the starter key is turned to the driving position or the front axle is rotating faster than 12 km/h the TCS is engaged again.

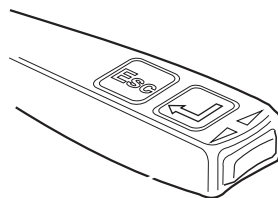

J3008810

## Note!

Switch off the TCS before towing with any axle raised!

## Note!

Switching off the TCS in the display disables the TCS switch.

## If TCS is activated after a wheel change

If you fit smaller wheels on the drive axle than what was fitted previously, the TCS may be activated.

Drive a distance at above 25 km/h. The EBS system then learns the difference between the wheel sizes. How far you need to drive depends on how big the difference in sizes is between the wheels.

It may be difficult to drive due to the TCS limiting the engine torque. In this case, engage the terrain-TCS.

The terrain-TCS allows larger differences in wheel speeds between the front axle and the driving axle. When the terrain-TCS is engaged, it takes longer for the EBS system to learn the difference in wheel sizes.

## Front wheel drive

- 1 Make sure none of the wheels are spinning
- 2 Engage the differential lock between the rear axles.  
The control lamp on the instrument panel will come on.

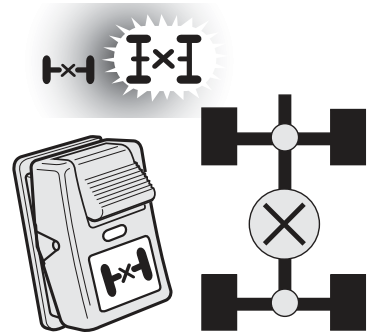

J4017789

- 3 Move the front-wheel drive switch to its bottom position.

The control lamp on the instrument panel will come on.

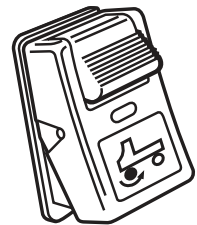

J4015829

# 136 Driving

---

- 1 Make sure none of the wheels are spinning
- 2 Set the switch to the lower position.

The control lamp in the instrument panel will light.

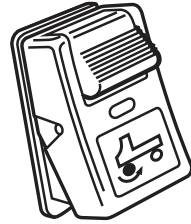

J4015829

## Differential lock

### Function

Firm ground, no differential lock engaged.

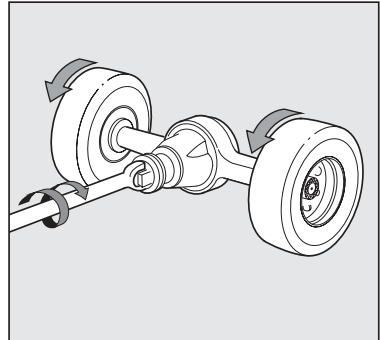

J0008648

Slippery surface, no differential lock engaged. Only the wheel on the slippery surface is rotating, the truck remains stationary.

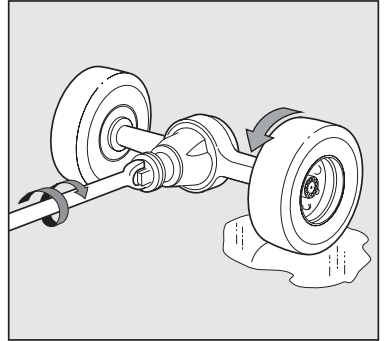

J0008649

Slippery surface, differential lock engaged. The wheels are forced to turn at the same speed. Only the wheel on firm ground drives. Accelerate carefully so that the driving axle and gear are not damaged. Disengage the differential lock when both wheels are gripping again.

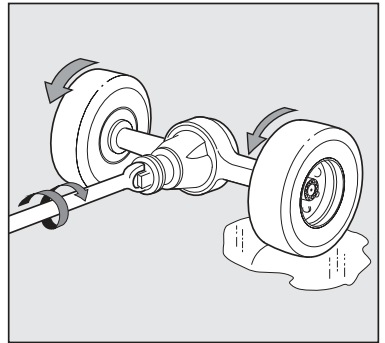

J0008650

## Engage differential lock

Engage the differential lock directly before coming on to the slippery surface and disengage the differential lock when the slippery surface has been passed.

None of the wheels may be spinning before the differential lock is engaged!

### **Warning!**

Drive carefully when the differential lock is engaged.  
Never turn corners on firm ground with the differential lock engaged.

- 1 Make sure none of the wheels are spinning
- 2 Depress the clutch pedal
- 3 Engage the differential lock
- 4 Release the clutch pedal
- 5 Accelerate **carefully** so that the driveshafts and gears are not damaged
- 6 Drive away from the slippery area
- 7 Release the accelerator
- 8 Disengage the differential lock

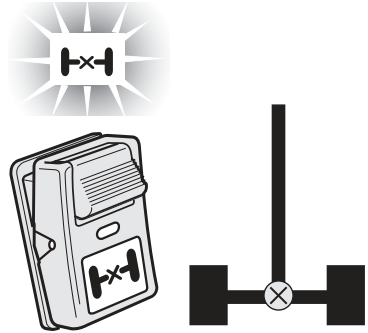

J4017788

The differential lock is engaged. The lamp on the instrument panel flashes.

### Note!

The differential lock is not engaged until the warning lamp on the instrument panel flashes. **The differential lock is engaged as long as the warning lamp is flashing, even if the switch is turned off.**

- 1 Make sure none of the wheels are spinning
- 2 Depress the clutch pedal
- 3 Engage the differential lock
- 4 Release the clutch pedal
- 5 Accelerate **carefully** so that the driveshafts and gears are not damaged
- 6 Drive away from the slippery area
- 7 Release the accelerator
- 8 Disengage the differential lock

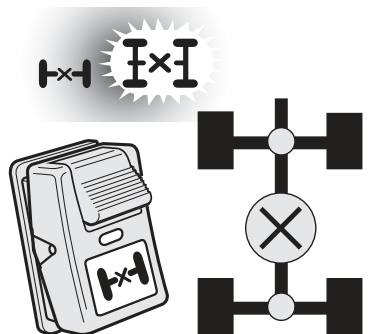

J4017789

**First position**, differential lock in transfer gearbox engaged. The lamp

on the instrument panel will come on.

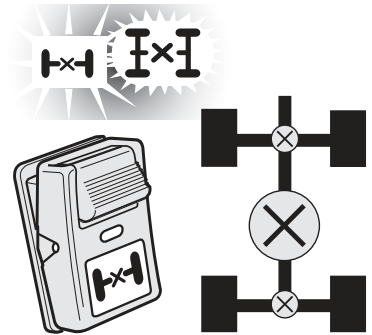

J4017790

**Second position**, differential lock in transfer gearbox and rear axles engaged. The axle differential lamp flashes and the lamp for the transfer gear comes on.

### Note!

The differential lock is not engaged until the warning lamp on the instrument panel flashes. **The differential lock is engaged as long as the warning lamp is flashing, even if the switch is turned off.**

### Note!

For long driving sessions with the differential lock between the axles engaged, make sure to drive a few hundred metres with the differential lock disengaged now and again.

## Differential lock

On vehicles with EBS, the differential lock can be engaged without depressing the clutch. On pressing the switch, the EBS system will attempt to synchronise the wheels so that they rotate at the same speed before engaging the differential lock. If this is not achieved within a certain time, the system will wait with the engagement of the differential lock until the wheels rotate at the same speed.

For automatic engagement of the differential lock, see “Automatic engagement of differential lock (DLC - Diff Lock Control)” on page

- 1 Set the switch to the lower position
- 2 Wait until the control lamp in the instrument panel flashes
- 3 Accelerate **with care** so as not to damage the drive shafts and gears
- 4 Drive away from the slippery area
- 5 Release the accelerator pedal
- 6 Disengage the differential lock

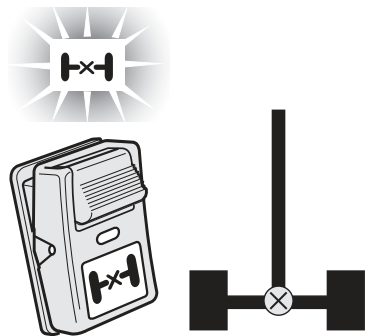

J4017788

The differential lock is engaged. The lamp on the instrument panel flashes.

### Note!

The differential lock is not engaged until the warning lamp in the instrument panel flashes. **The differential lock is engaged as long as the warning lamp is flashing, even if the switch is turned off.**

## Engage the differential lock between the axles

- 1 Put the switch in the centre position
- 2 Wait until the control lamp on the instrument panel lights

The differential lock between the axles is engaged.

To engage the differential lock between axles without activating DLC, engage terrain-TCS. See “Terrain-TCS” on page .

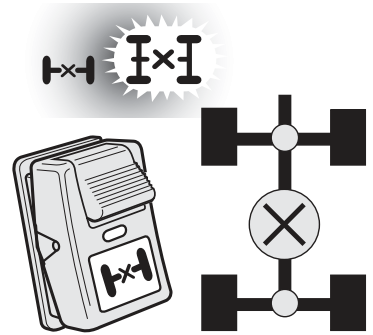

J4017789

**Intermediate position**, differential lock in transfer gearbox engaged. The lamp on the instrument panel will come on.

### Note!

For long driving sessions with the differential lock between the axles engaged, make sure to drive a few hundred metres with the differential lock disengaged now and again.



## Engage the differential lock between all wheel-pairs

- 1 Set the switch to the lower position
- 2 Wait until the control lamp in the instrument panel flashes  
The differential locks between all wheel-pairs are engaged
- 3 Accelerate **with care** so as not to damage the drive shafts and gears
- 4 Drive away from the slippery area
- 5 Release the accelerator pedal
- 6 Disengage the differential lock

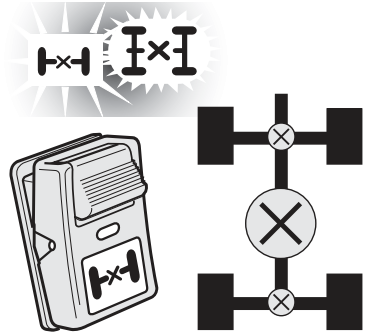

J4017790

**Lower position**, differential lock in transfer gearbox and rear axles engaged. The axle differential lamp flashes and the lamp for the transfer gear comes on

### Note!

The differential lock is not engaged until the warning lamp in the instrument panel flashes. **The differential lock is engaged as long as the warning lamp is flashing, even if the switch is turned off.**

## Differential locks

Engage the differential lock just before reaching the slippery surface and disengage it once you have past the slippery surface.

None of the wheels may be spinning before the differential lock is engaged!

- 1 Make sure none of the wheels are spinning
  - 2 Depress the clutch pedal
  - 3 Engage the differential lock between the rear axles.
- The control lamp on the instrument panel will come on.



### Warning!

Drive carefully once the differential lock is engaged. Never turn corners on firm ground with the differential lock engaged.

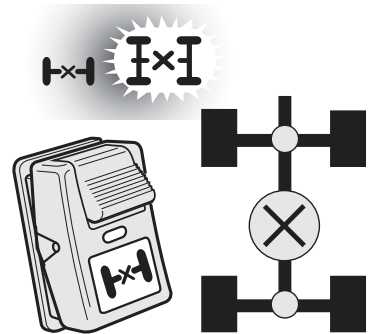

J4017789

**First position**, differential lock in transfer gearbox engaged. The lamp on the instrument panel will come on.

4 Engage the differential lock between the wheels on the rear axles.

The control lamp on the instrument panel will flash.

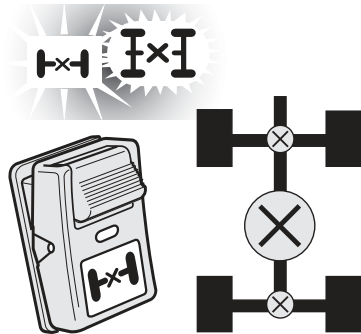

J4017790

**Second position**, differential lock in transfer gearbox and rear axles engaged. The axle differential lamp flashes and the lamp for the transfer gear comes on.

**Note!**

The differential lock is not engaged until the warning lamp on the instrument panel flashes. **The differential lock is engaged as long as the warning lamp is flashing, even if the switch is turned off.**

5 Move the front-wheel drive switch to its bottom position.

The control lamp on the instrument panel will come on.

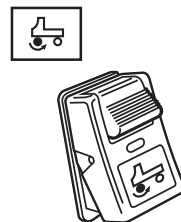

J4015829

**6** Engage the differential lock between the front wheels.

The control lamp on the instrument panel will come on.

**7** Release the clutch pedal

**8** Drive away from the slippery area

**9** Release the accelerator

**10** Disengage the differential lock

The differential lock between the front wheels will be disengaged if the differential lock between the rear axles, the differential lock between the wheels on the rear axles or the front-wheel drive is disengaged.

Engage the differential lock just before reaching the slippery surface and disengage it once you have past the slippery surface.

None of the wheels may be spinning before the differential lock is engaged!



J4015830



## Warning!

Drive carefully once the differential lock is engaged. Never turn corners on firm ground with the differential lock engaged.

**1** Make sure none of the wheels are spinning

**2** Depress the clutch pedal

**3** Engage the differential lock between the rear wheels.

The control lamp on the instrument panel will flash.



J4015831

## Note!

The differential lock is not engaged until the warning lamp on the instrument panel flashes. **The differential lock is engaged as long as the warning lamp is flashing, even if the switch is turned off.**

**4** Move the front-wheel drive switch to its bottom position.

The control lamp on the instrument panel will come on.



J4015829

**5** Engage the differential lock between the front wheels.

The control lamp on the instrument panel will come on.



J4015830

**6** Release the clutch pedal

**7** Drive away from the slippery area

**8** Release the accelerator

**9** Disengaging the differential locks

The differential lock between the front wheels will be disengaged if the differential lock between the rear wheels or the front-wheel drive is disengaged.

## Automatic engagement of the differential lock (DLC – Diff Lock Control)

Set the switch for the differential lock to the centre position.

The differential lock is engaged automatically when the driving wheels rotate at different speeds and the speed is less than 15 km/h.

The differential lock is disengaged if the speed exceeds 15 km/h or at the next gear change.

When the truck is delivered from the factory, the automatic differential lock between the wheel pairs is disengaged. This can be changed in the “Automatic diff lock” menu under the main heading “Vehicle settings” in the display.

Set the switch for the differential lock to the centre position.



J5013702

DLC becomes active. On trucks with two driven axles, the differential lock between axles will also be engaged.

The differential lock is engaged automatically when the driving wheels rotate at different speeds and the speed is less than 15 km/h.

The differential lock is disengaged if the speed exceeds 15 km/h or at the next gear change.

## Overview of the switch's functions

Switch position	Function
0 (upper position)	No differential lock engaged.
1 (centre position) and TCS engaged	DLC active.
1 (centre position) and terrain-TCS engaged	DLC inactive.
1 (centre position) and TCS disengaged	DLC inactive.
2 (lower position)	The differential lock is manually engaged.

Switch position	Function
0 (upper position)	No differential lock engaged.
1 (centre position) and TCS engaged	The differential lock between the axles is engaged. Automatic engaging and disengaging of the differential lock between the wheel pairs depending on the speed conditions according to the above description.
1 (centre position) and terrain-TCS engaged	The differential lock between the axles is engaged.
1 (centre position) and TCS disengaged	The differential lock between the axles is engaged.
2 (lower position)	The differential lock between the axles is engaged. Differential locks are engaged between each wheel pair.

## Auxiliary brakes

### General

Use auxiliary brakes to avoid overheating in the brakes on longer downgrades and to reduce wear on the brake linings.

If the truck is driven on steep downhill slopes without a load, there is a risk of jack-knifing if the auxiliary brakes apply too hard.

The brake lamps light if the auxiliary brakes are applied hard enough.

On vehicles with air suspension which do not have a full load the braking effect of the auxiliary brake is diminished.

On tractors without ABS or EBS, the engine brake is only engaged when a trailer is coupled.

On trucks with ABS or EBS the auxiliary brakes are disengaged if the wheels start to lock. The auxiliary brakes can also be disengaged if the ABS fails.

On trucks with ESP the auxiliary brakes are also disconnected if this is necessary to retain stability.

### Driving instructions for the compact retarder

Trucks with compact retarders must be run at high engine speed when the retarder is engaged. If the engine speed is too low, the oil will not be cooled properly. If the oil is not cooled properly, the effect of the compact retarder will be reduced and remain low until the oil temperature is sufficiently low again. High engine speed when braking does not negatively effect fuel consumption.



#### Warning!

Do not use the auxiliary brake on slippery roads because of the risk of the wheels locking and of skidding. The auxiliary brake brakes only on the drive wheels which means that there is risk of jack-knifing. Instead brake with the brake pedal which acts on all wheels. Drive with sufficient safety margins.

## Switch with two positions

- Position 0, the auxiliary brake is not engaged
- Position 1, the auxiliary brake is engaged

Release the accelerator pedal for the auxiliary brake to take effect.

In order for the auxiliary brakes to function when the accelerator is released during driving,

- the truck must be in gear, and
- the clutch must be released
- the engine speed must be at least 1000 rpm, but preferably as high as possible without entering the tachometer red zone
- the cruise control must be disengaged

If the cruise control is engaged, the auxiliary brakes first start working when the speed is 7 km/h above the set speed.

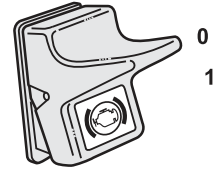

J0008637

## Switch with three positions

- Position 0, the auxiliary brake is not engaged
- Position 1, the auxiliary brake is semi-engaged
- Position 2, the auxiliary brake is fully engaged

Release the accelerator pedal for the auxiliary brake to take effect.

In order for the auxiliary brakes to function when the accelerator is released during driving,

- the truck must be in gear, and
- the clutch must be released
- the engine speed must be at least 1000 rpm, but preferably as high as possible without entering the tachometer red zone
- the cruise control must be disengaged

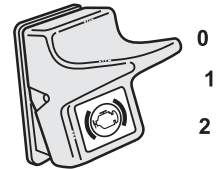

J0008058



If the cruise control is engaged, the auxiliary brakes first start working when the speed is 7 km/h above the set speed.

Full auxiliary brakes (position 2) cannot be engaged before the engine has attained working temperature. If the engine brake is engaged at too low a temperature, a symbol is shown in the display or amongst the check lamps and the information lamp lights.



J3014455

Symbol which shows that the temperature is too low.

## Stalk

A figure or letter in the display shows which position the lever is in.

### Automatic position A

The auxiliary brakes start working together with the service brakes when the brake pedal is depressed ("Brake blending"). It is only in position "A" that the auxiliary brakes begin to take effect together with the normal wheel brakes when the brake pedal is depressed.

If the engine cruise control is engaged, it uses the auxiliary brakes to keep the set speed.

### Manual positions 1-3

The auxiliary brake will be applied increasingly for each step of the stalk switch. A Volvo workshop can change the degree to which the auxiliary brake is engaged at each position.

There are even stalk switches with only manual positions. Manual position means that full auxiliary braking is engaged.

Release the accelerator pedal for the auxiliary brake to take effect.

In order for the auxiliary brakes to function when the accelerator is released during driving,

- the truck must be in gear, and
- the clutch must be released

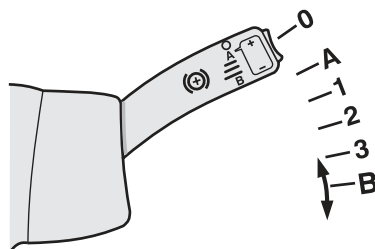

J0010263

**0** Auxiliary brake disengaged

**A** Automatic position

**1-3** Manual position

**B** Braking program (only on trucks with I-shift or Powertronic)

The display shows that the stalk is in position 2.

	11:45
	AM
(2)	7,658.8 km

- the engine speed must be at least 1000 rpm, but preferably as high as possible without entering the tachometer red zone
- the cruise control must be disengaged

## Brake program B

- 1 Stop in the last manual position (3 for stalk switch with three manual positions and 1 for stalk switch with one manual position)
- 2 Pull the lever to position B
- 3 B is shown on the display
- 4 Release the lever

	11:45
	AM
(B)	7,658.8 km

When the brake program is connected the gearbox changes to the gear which gives the auxiliary brake the best effect.

Leave the brake program by positioning the lever in some other position than position 3 or by depressing the accelerator.

## Cruise control with braking

### When the engine cruise control is disengaged

- 1 Drive at the desired speed
- 2 Put the lever in position A
- 3 Depress the toggle switch on the lever
- 4 The speed is set and the accelerator can be released

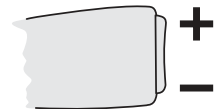

J5012647

The truck brakes automatically when the set speed is exceeded. Increase or decrease the set speed with the toggle switch.

The truck can be braked manually with the lever in positions 1-3, and returns to braking at the set speed when the lever is moved to position A again.

Disengage the cruise control with braking by pressing the accelerator or putting the lever in position 0.

### When the engine cruise control is engaged

Put the lever in position A

# 152 Driving

---

The engine's cruise control uses the auxiliary brakes for braking when the speed is 7 km/h above the set speed. 7 km/h excess speed is installed at the factory but can be changed to between 3 and 15 km/h. Depress + or - on the toggle switch to increase or decrease the excess speed. For a short time the display will show at what speed above the set speed the auxiliary brake will begin to take effect.

When the speed is down to 4 km/h above the set speed, the auxiliary brakes stop braking.

The truck can be braked manually with the lever in positions 1-3, and returns to braking at the set speed when the lever is moved to position A again.

Disengage the cruise control with braking by pressing the accelerator or putting the lever in position 0.

Disengage the engine cruise control by pressing the brake pedal or the clutch pedal.

## Brake Blending

When the auxiliary brake lever is in position A, the auxiliary brake is automatically applied together with the normal brakes when the brake pedal is depressed.

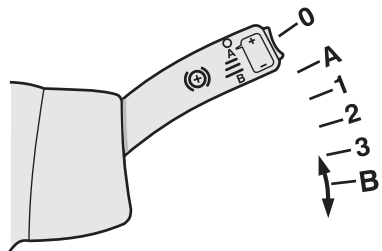

J0010263

Put the lever in position A

## ABS

ABS is a part of EBS and is completely automatic.

## ESP — Electronic Stability Program

ESP (Electronic stability program) is a stabilising system that reduces the risk of rolling over and skidding.

If the system senses that the vehicle is about to roll over, it first reduces the throttle. If this is not sufficient, the system also uses the wheel brakes to reduce the vehicle's speed. The system works best when the trailer also has ABS or EBS .

If the system senses that there is a risk for skidding, the throttle is reduced and the wheels are braked in a manner that allows the vehicle to continue on the correct course. If necessary, the auxiliary brakes are also disconnected.

A symbol lights when the system is acting.



J3015844

Symbol for ESP engagement.



### Warning!

Drive the truck in the same way as vehicles without ESP. ESP reduces the risk of tipping and skidding, but the vehicles can still tip over if the centre of gravity is very high, if the wheels hit a curb at high speed, or through careless driving. A truck can skid on slippery surfaces even if it has ESP.

Do not drive on heavily cambered roads (e.g. test tracks) with vehicles fitted with ESP. Driving on heavily cambered roads can cause the ESP system to engage unnecessarily and dangerously.

## Control of engine torque

When the accelerator pedal is released on a slippery road, the auxiliary brake can lock the driving wheels. When this happens the auxiliary brake is disengaged and the engine is accelerated until the driving wheels rotate at the same speed as the front wheels. This does not happen if the gearbox is in neutral position, ABS is activated or the vehicle speed is lower than 10 km/h.

## Brake lining wear equalisation

If the brake linings on one axle wear faster than on the others, the braking force is altered to equalize the wear.

A symbol is shown on the display when there is less than 20% of the lining left.



J5013668

Symbol on the display when there is less than 20% of the brake lining left.

## Panic braking function

If the brake pedal is depressed very quickly, the brake pressure is rapidly increased and the braking effect is more powerful. The function is provided to reach full braking force more quickly in emergency situations.

## Manual gearbox

### General

Starting **always** start in 1st gear or crawler gear with as low engine speed as possible (700–800 rpm). Do not slip the clutch. Select the next gear as soon as the truck is rolling. Let the engine work within its most efficient range, the lower part of the tachometer's green field. Only use full power when you really need it. **Drive according to the tachometer, not the engine sound!**

### Reverse gear

The reverse gear is unsynchronised. Shift to LOW range before engaging reverse. In good driving conditions it is possible to reverse with HIGH range engaged.

To get into reverse gear more easily, engage a synchronised gear before the reverse gear. This stops the gearbox shafts from rotating and the engagement teeth are not worn so much.

### Note!

It is not permitted to shift between HIGH and LOW range while reversing. First shift to HIGH or LOW range, then engage reverse.

## Crawler gear

Some gearboxes have a crawler gear (C).

Crawler gear is not synchronised and can only be used in low range. First select low range and then engage crawler gear. Use the crawler gear in difficult starting conditions, i.e. if you are stuck or when starting with a heavily loaded truck on a hill.

In order to engage the crawler gear more easily, engage a synchronised gear before engaging the crawler gear. This stops the gearbox shafts from rotating and the engagement teeth are not worn so much.

## Change between low speed range and high speed range

The gearbox is divided into a low speed range and a high speed range. The lower figure in each gear position shows the low speed range. The upper figure in each gear position shows the high speed range.

- 1 Change gear as with a conventional gearbox to the highest speed in the low speed range (3rd or 4th)
- 2 Raise the range to the upper level (H)
- 3 Depress the clutch
- 4 Put the gear lever in neutral
- 5 Wait until the gearbox has changed up to the high speed range
- 6 Engage the next gear (4th or 5th)
- 7 In high speed range change as with a conventional gearbox

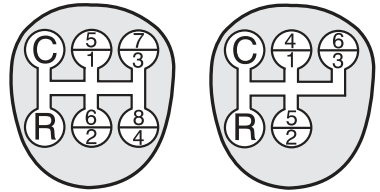

J0007815

Change down in the same way.

A range inhibitor prevents shifting to the low speed range if the speed is higher than 20–40 km/h.

Before each new gear hold the gear lever in neutral for a moment.

When changing gear it is possible to skip a gear position if the total weight and general driving conditions permit it.

Range control:

H High Speed Range

L Low Speed Range

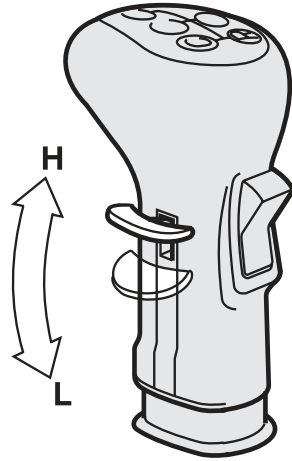

J0007816

**Note!**

If the air pressure is too low the range gear can become stuck in neutral. The gear lever is then locked into neutral. The gear lever can be moved when the air pressure increases.

## Change between high splitter and low splitter

Change within the same gear:

- 1 Begin with the splitter gear in position L, low splitter. The symbol for low splitter lights up.
- 2 Change the splitter gear to position H, high splitter
- 3 Wait for suitable engine speed
- 4 Push the clutch right down
- 5 The gear will engage and the low splitter symbol will go out
- 6 Release the clutch

Change to the next gear:

- 1 Set the position control in position L, low splitter
- 2 Wait for suitable engine speed
- 3 Push the clutch right down
- 4 Put the gear lever in the next gear position
- 5 The gear is engaged and the symbol for low splitter lights up
- 6 Release the clutch

Change down in the same way.

If the clutch is not depressed completely the gear change can be delayed, the gearbox can get into neutral and the synchronising can be damaged.

When starting in crawler gear, the splitter control **must** be used: Change from low crawl to high crawl, to low 1st gear, and so on. Changing gear from low crawl directly to low 1st gear often means that the truck will stop before you have time to get into 1st gear.

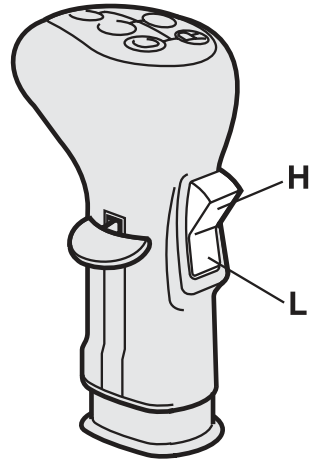

J0007819

Splitter Control:  
 H High split  
 L Low split



J3014477

Symbol for engaged low splitter



## Hydraulic bogie lift

### Lifting the bogie axle

- 1 Depress the upper part of the switch. A signal is sounded indicating that the bogie lifting motor is functioning.
- 2 Wait until the control lamp lights up. The bogie axle is now completely lifted.
- 3 Put the switch in the middle position.

The indicator lamp in the switch only shows that the switch is switched on.

### Lowering the bogie axle

- 1 Depress the lower part of the switch. A signal is sounded indicating that the bogie lifting motor is functioning.
- 2 Wait until the control lamp lights up. The bogie axle is now completely lowered.
- 3 Put the switch in the middle position.

The indicator lamp in the switch only shows that the switch is switched on.

Avoid quick movements between the upper and lower switch positions. Pass the middle position slowly, so that the indicator lamp in the switch has time to go out, otherwise there will be no change-over.

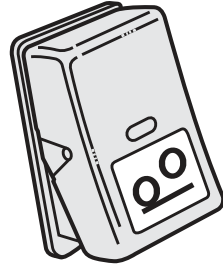

J0007833

Switch for bogie.



J3014468

Control lamp for bogie.

### **Note!**

If the switch for the bogie is depressed the bogie lift must be allowed to become ready before the switch is put in the middle position again, otherwise the truck can suffer damage.

### **Note!**

Never use the bogie lift as long as the control lamp for preheating is lit.

 **Caution!**

Lower the bogie when tipping and when driving with a loaded vehicle. Otherwise damage can result as the maximum loading is exceeded.

## Bogie

### Bogie lamp

The tag axle raise lamp is lit when:

- The bogie axle is lifted
- Load distribution between the drive axle and bogie axle is changed

The bogie lift lamp lights when the load distribution between the drive axle and bogie axle is changed.

The bogie lift lamp flashes when:

- The drive axle load has increased by 30% on vehicles which have a bogie button with a spring loaded lower position.



J3014468

Bogie lift lamp

## Lifting and lowering the bogie axle

### Lifting the bogie axle

Set the bogie axle switch to the upper position.

The bogie axle raised lamp on the instrument panel lights up and remains on as long as the switch is in the upper position.

The lamp always flashes when the speed is below 30 km/h, axle load limits are exceeded and the function is active.

The bogie axle will not lift if the pressure on the drive axle exceeds the axle pressure limit.

### Note!

The rear suspension is raised 45 mm when the switch is in the upper position. The increase in height means the vehicle's total height also is increased. The offset height can be adjusted at a Volvo workshop.

The bogie axle is not lifted, instead the load is distributed to the other axles when the switch is set to the upper position.

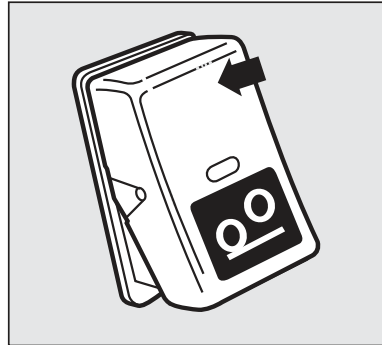

J7008416



J3014468

Bogie lift lamp

## Lowering the bogie axle

Move the bogie axle switch to the centre position. The bogie axle raise lamp on the instrument panel is extinguished.

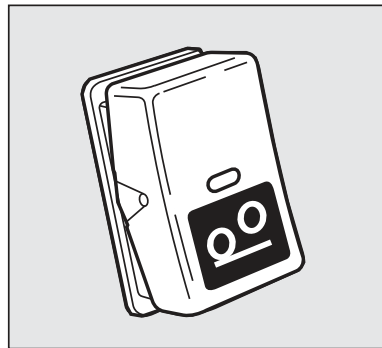

J7008420

## Change load distribution between drive axle and bogie axle

To change the load distribution, the bogie axle is drained from air so that more weight is transferred to the drive axle. The bogie axle is not lifted, it has contact with the road surface all the time. The function

can be used to increase traction when stuck on a slippery surface.

**1** Press the lower part of the bogie switch once.

The load is distributed so that the drive axle carries a heavier load than previously, but not more than the axle load limitation. The bogie lamp is lit.

The function "Optimize traction" is activated. The function distributes the load between the axles to provide the best road grip possible with regard to the load

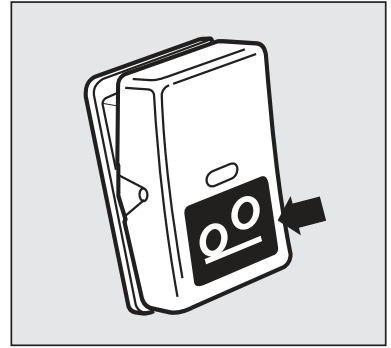

J7008415

**2** Press the lower part of the bogie switch once more.

If the speed is less than 30 km/h when it is pressed:

The drive axle pressure increases to max 30% above the axle pressure limit. The bogie lamp flashes.

When the speed increases to more than 30 km/h, the drive axle load drops to the axle load limit again.

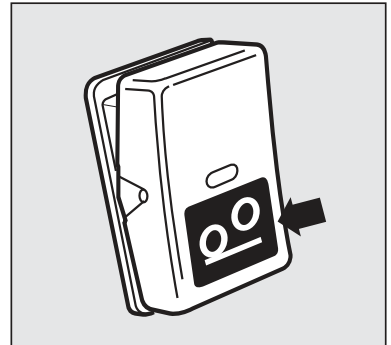

J7008415

## 162 Driving

---

**3** Press the lower part of the bogie switch a third time.

The air bellows for the bogie axle are inflated so that axle loading is distributed evenly again. The bogie lamp goes out.

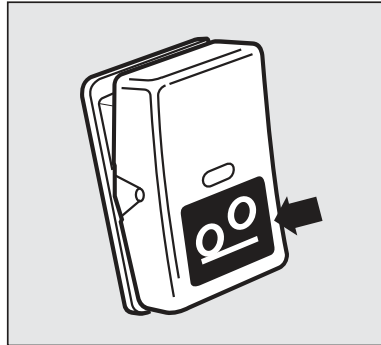

J7008415

**1** Press the lower part of the bogie switch once.

If the speed is less than 30 km/h when it is pressed:

The drive axle pressure increases to max 30% above the axle pressure limit. The bogie lamp flashes.

When the speed increases to more than 30 km/h, the drive axle load drops to the axle load limit again.

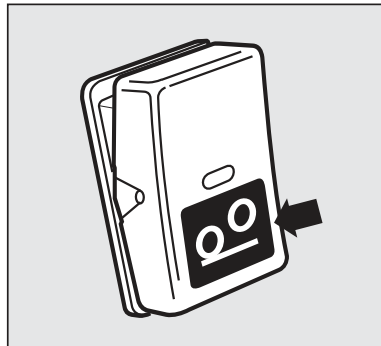

J7008415

**2** Press the lower part of the bogie switch once more.

The function "Optimize traction" is re-activated. The function distributes the load between the axles to provide the best road grip possible with regard to the load. The bogie lamp goes out.

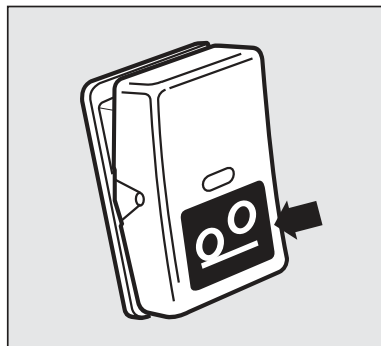

J7008415

1 Engaging the diff lock between axles.

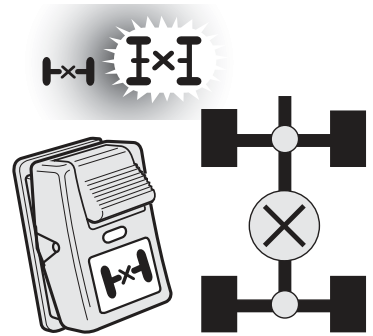

J4017789

2 Set the bogie switch to the lower position.

The load is distributed so that the drive axle carries a heavier load than previously. The bogie lamp is lit.

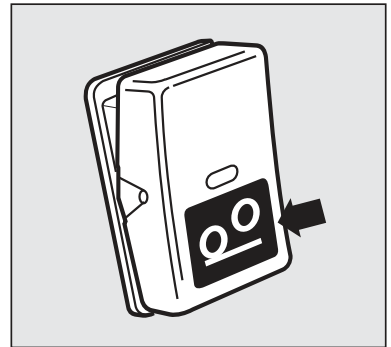

J7008415

To return to normal driving:

- 1 Put the bogie switch in the centre position
- 2 Disengage the diff lock

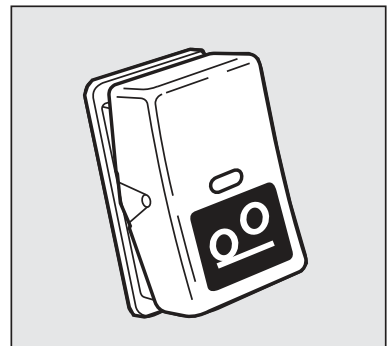

J7008420

Set the bogie switch to the lower position.

The load is distributed so that the drive axle carries a heavier load than previously. The bogie lamp is lit.

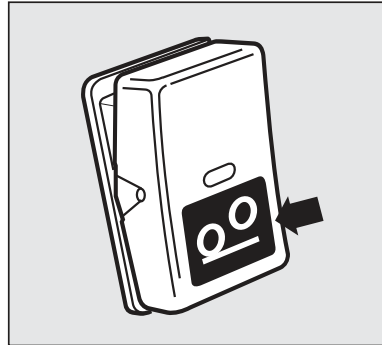

J7008415

To return to normal driving:

- 1 Put the bogie switch in the centre position
- 2 Disengage the diff lock

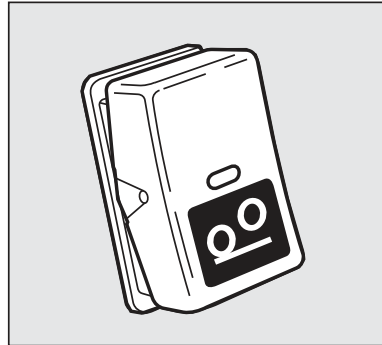

J7008420

## Unloading the front axle

On the front axle bellows there is a sensor that measures the load on the front axle. When the load becomes excessive, the front axle is automatically relieved by lowering the bogie. With excessive front axle loading and if the speed exceeds 30 km/h, the system automatically reverts to, firstly, "traction help", secondly, "optimize traction" and finally normal axle load distribution. If the load on the front axle is too high, the bogie cannot be raised.

## Tridem

### Raise the axle

Depress the upper part of the switch.

The bogie lamp for the Tridem-axle lights up.

If the load on the other axles becomes excessive, the axle will not lift.

If the axle lifts, the rear part of the vehicle will be raised by 45 mm.

If the axle is lifted and the vehicle is loaded so that the pressure on the bogie becomes excessive, the Tridem-axle will be lowered automatically.

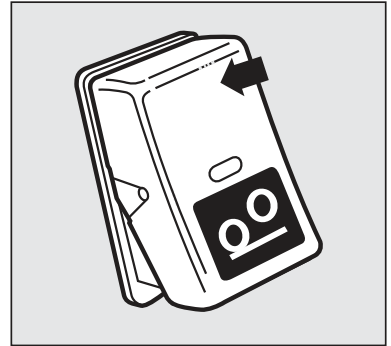

J7008416



J3014469

Bogie lamp for Tridem-axle

### Lower the axle

Put the switch in the middle position.

The bogie lamp for the Tridem-axle goes out.

The load is distributed so that both driving axles receive equal load. The third axle will receive sufficient load to make the vehicle as easy to drive as possible.

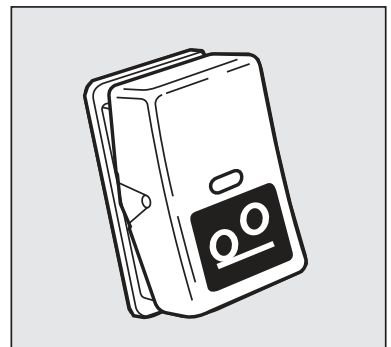

J7008420



## Distribute the load evenly between the axles

With high bogie pressure, for example, when loading and unloading, it can be advantageous to increase axle pressure on the Tridem-axle in order to obtain the best possible stability.

Depress the lower part of the switch.

The bogie lamp for the trailer flashes.

The load is evenly distributed over the three axles. The bogie becomes more stable.

The load on the third axle never exceeds 8 tonnes, even if the load on the bogie exceeds 24 tonnes.

The function is switched off when the speed exceeds 30 km/h.

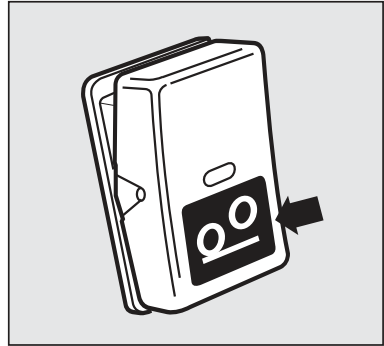

J7008415



J3014469

Bogie lamp for Tridem-axle

## Increase the axle pressure on the first drive line

Engage the differential lock between the driving axles.

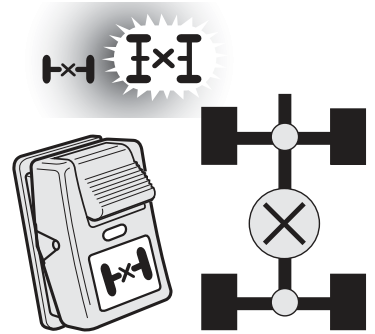

J4017789

Then depress switch "AIR DUMP":

- 1 First press: The second drive axle is dumped so that 10.5 tonnes is put on on the first drive axle. The bogie lamp lights up
- 2 Second press: The second drive axle is dumped so that 13.6 tonnes is put on on the first drive axle if speed is less than 30 km/h. The bogie lamp flashes.
- 3 Third press: The second driving axle is loaded again, and the load distribution between the axles will be 50/50. The bogie lamp goes out



J3014127

If the weight on the first driving axle becomes excessive, the increase in axle pressure will be discontinued. Distribution between the driving axles will be 50/50.



J3014468

Bogie lamp

The Tridem-axle is not affected at all by the switch "AIR DUMP".

## Steered rear axle

The truck may have a hydraulically steered pusher axle or a hydraulically steered trailing wheel axle, controlled electronically.

If a fault occurs in the electro-hydraulic system the axle will be completely unsteered and it will not be possible to reverse the truck unless the axle is raised. Remember that a fault in the system also effect the driving characteristics when driving straight forwards.

Small simple faults can be corrected by stopping the truck, turning the ignition key to 0, waiting a short while and then restarting the engine.



### Warning!

Do not try to fix any faults on the steering of the pusher axle or trailing wheel axle yourself but contact a Volvo workshop.



### Warning!

In case of any fault with the steering for the pusher axle or the tag axle, contact your closest Volvo workshop. Reversing must be avoided as this can damage the truck. There is a great risk that components e.g. hubs, bearings, wheels can suffer permanent damage and must be replaced.

## Cruise control

Depress the brake pedal for a couple of seconds after starting the engine otherwise the cruise control will not function.



### Caution!

Do not use the cruise control in hilly terrain, heavy traffic or on slippery roads.

### Engage the cruise control

The slide switch for cruise control is on the direction indicator.

- 1 Move the slide switch (B) to the ON position.
- 2 When the required speed has been attained press SET (A).  
The required speed is attained either by using the accelerator in the usual way or by increasing or decreasing speed with + or - on SET.

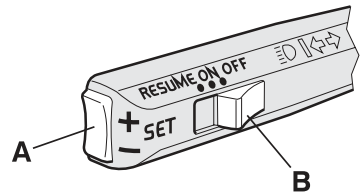

J0008305

When cruise control is in operation, this is indicated on the display by "CC" or by an indicator lamp.

The cruise control cannot be engaged at speeds below 30 km/h.

### To disengage cruise control

Depress the brake pedal or the clutch pedal or push the slide switch (B) to OFF.

Return to the previous speed by pushing the slide switch (B) to RESUME and release. (This is valid as long as the speed exceeds 15 km/h when the slide switch (B) is depressed).

The cruise control is not disengaged if the accelerator pedal is depressed. When the accelerator is released, the truck returns to the set speed.

### Note!

Make a habit of using one of the foot pedals to disengage cruise control in order to be able to react as quickly as possible in the event of a critical situation.

## Constant engine speed control

The engine can be held at another speed than idle, for example when the power take-off is in use. The truck must be stationary. (To change the idle speed temporarily, see section "Constant engine speed control")

### Note!

Never set the engine speed higher than the body builder's recommendation. See information from the body builder.

### Choice of engine speed

- 1 Push B to ON
- 2 Change the engine speed with SET (A)

### Preset engine speed

Push B to RESUME.

The preset engine speed is normally 1000 rpm.

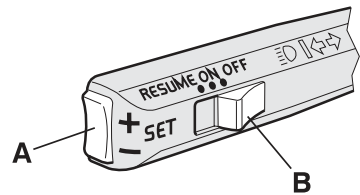

J0008305

### Disengage engine speed control

There are four different ways of disengaging the engine speed control. Do one of the following:

- Push B to OFF
- Depress the clutch pedal
- Depress the brake pedal
- Use the trailer brake

## Lane Keeping Support

Lane Keeping Support is a driving support system aimed at warning the driver for unintentional deviation from the intended direction. The main area of use for the system is on motorways when the truck has a speed above 60 km/h and in monotonous driving conditions.

## Engaging Lane Keeping Support

The system is operated via a switch on the instrument panel. When the system is switched off, no icons are displayed. When the system is switched on, the status is shown with two icons, see below.

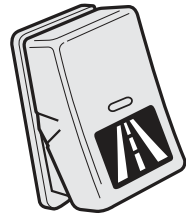

When the system is **SWITCHED ON** and **ACTIVE** the following symbol is shown on the display. That the system is **ACTIVE** means that the system will warn the driver with unintentional deviations from the driving lane.



When the system is **SWITCHED ON** but **INACTIVE** the following symbol is shown on the display. The system will **NOT** warn the driver with unintentional deviations from the driving lane. Examples of when the system is inactive are; when there are no lane markings or poor markings, when the speed is below 60 km/h.



When the system is active, a warning signal is generated from the instrument panel. The signal is a long, repeated signal that resembles the noise from lane edge markings.

### When does the system warn?

The system warns the driver when the truck crosses lane markings and the following conditions are fulfilled:

- The system is **SWITCHED ON**
- The system is **ACTIVE**
- The truck speed is **60 km/h or higher**
- The driver has **not** used the direction indicators or **recently touched the brake pedal**

The system does **not** effect the brakes, steering or any other system in the truck. It only emits an audible

signal via the instrument panel and shows icons on the display

The system occasionally requires automatic calibration. This may be when the truck is started for the first time or after a workshop visit. When calibration is required, it starts automatically as soon as the speed is sufficient and the road markings are legible, independent of if the system is active or inactive. Calibration takes about 20 minutes, but the system is functional after 5-7 minutes.

## Lane Change Support

Lane Change Support is an information system that, in certain circumstances, helps to make the driver aware of vehicles that are travelling in the same direction as the truck on the passenger side (in the blind spot).

The main purpose of the system is when driving on multi-lane roads, where the system can minimise the risk of accidents when changing lanes.

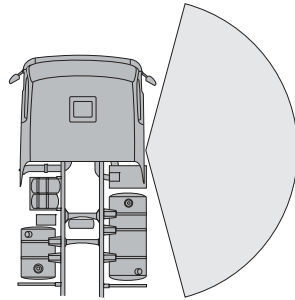

### Warning!

The system is a supplement to a safe driving style and the use of rear-view mirrors. It cannot replace the driver's awareness and responsibility. The responsibility for changing lanes in a safe manner always lies on the driver.

**Note!**

The system does not affect the brakes, steering or other systems in the vehicle. It only emits warning light and sound signals.

**Engaging Lane Change Support**

LCS is activated automatically when the truck starts. The system functions when the truck's speed is above 35 km/h.

The passenger side door pillar has an LED marked with the symbol to the right. This shows a steady light when LCS is active.

LCS can be switched off in the display menu, see the section for Display – Vehicle settings – LCS.



J151617

Symbol for Lane Change Support

**When does the system warn?**

The system warns when the following conditions are fulfilled:

- The truck has a speed in excess of 35 km/h
- The direction indicators are on
- Another vehicle is moving within the sensor's field of view

The system warns with a flashing LED on the passenger door pillar and a sound signal. The sound signal is turned off when the truck is delivered from the factory and can be activated via the display menu. See the section for Display — Vehicle settings — LCS sound signal.

**Note!**

The system does not issue warnings if the vehicle alongside is moving at a speed considerably faster or slower than the truck.



## If the LCS does not work

LCS can be limited by snow, ice or dirt in the close vicinity of the sensor and in some weather conditions, such as snowfall

or heavy rain. The sensor function can be impaired by e.g. an extremely wide load, superstructures or other fixed

installations within the sensor's field of view. If an alteration to the superstructure or other modification has been made within or close to the sensor's field of view, the LCS function should be checked by a workshop.

LCS does not warn for pedestrians, cyclists or fixed objects within the sensor's field of view and can in certain situations

have difficulty in detecting motorcycles and mopeds.

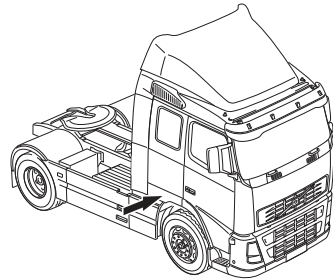

J161417

The arrow shows the location of the sensor on a left-hand drive truck



### Warning!

Any modifications to the area in front of the sensor will result in Volvo not being able to guarantee the correct function of the LCS.

## Driver Alert Support

Driver Alert Support is a driving support system, the purpose of which is to inform the driver of his or her awareness when driving.

The function is intended to attract the drivers attention when he/she starts to exhibit impaired driving ability, e.g. if the driver starts to fall asleep.

The main area of use is on larger main roads. The function is not intended for use in town traffic.



### Warning!

Driver Alert Support does not function in all situations, it is only intended to be a supplementary aid. The driver is ultimately responsible for driving the vehicle in a safe manner.

The system is controlled from the display menu, see “Vehicle settings” in the Display section. DAS can be selected as a favourite in the display.

DAS is activated automatically when the truck starts. The system is activated at a speed of 65 km/h, when it is switched on via the display.

The display shows a level indicator with 1–5 bars. If no bars are visible, the system is inactive or turned off. In order for the symbol to be seen in the display, DAS must be selected as a favourite, see the Display section.

The system is inactivated at speeds below 60 km/h.

DAS provides information to the driver in the form of bars in the display. The number of bars decreases with deteriorated lane keeping. The driver is alarmed when the vehicle does not follow road markings in an even manner. The alarm warns via a message in the display and a sound signal.

The up/down buttons are used for scrolling between the messages. Use the Esc button to close a message.

For the DAS to function, the following conditions must be met:

- The system is engaged
- The road has legible lane markings
- The truck has a speed in excess of 65 km/h

## Note!

The system does not affect the brakes, steering or other systems in the vehicle. It only emits audible signals via the instrument panel and shows messages in the display.



## Warning!

Driver Alert Support can be inactivated by indistinct road markings or certain weather conditions, e.g. heavy rain or snowfall.



J153857

Level marking for  
Driver Alert Support

## Note!

DAS should not be used to increase the length of a driving session. Tiredness is deceptive and it is difficult to sense when it is starting to become dangerous. So make sure that you are properly rested before a journey and take regular breaks.

DAS detects most cases where the driver's concentration on driving is detracted, e.g. due to tiredness or poor concentration. To increase safety even more the Lane Keeping Support should be activated.

## **Calibration**

The system occasionally requires automatic calibration. This may be when the truck is started for the first time or after a workshop visit. When calibration is necessary, it is started automatically as soon as the speed is sufficient and the road markings are sufficiently distinct, irrespective of the system being active or inactive. The calibration takes about 20 minutes, but the system functions already after 5–7 minutes.

## **Power take-off**

### **General**

One differentiates between Power Take-Offs that are mounted on engines, flywheels and gearboxes. A PTO mounted on a flywheel is called a clutch-dependant PTO.

All power take-off is disengaged when the engine is switched off with the starter key, when the power take-off is engaged. When the engine is started the next time the power take-off is disengaged despite the fact that the switch is on. Turn the switch off before the power take-off is engaged again. If the engine is switched off remotely, the power take-off will not be disconnected, and will remain connected when restarting.

On ADR vehicles, the parking heater will not start if the power take-off is engaged. The parking heater is turned off if it is on when the power take-off is engaged.

With "Constant engine speed control" the idle can be temporarily raised, so that it is higher while the power take-off is being used. The idling speed can be raised by different amounts, depending on which type of power take-off is installed in the truck.

**Note!**

Never set the engine speed higher than the body builder's recommendation. See information from the body builder.

**Engine-mounted power take-off**

Engine-mounted power take-offs can be engaged or disengaged while travelling without depressing the clutch.

On trucks with I-shift it will not be possible to change gear if the power take-off is engaged while driving. The desired gear must be selected while the truck is stationary.

The engine speed is limited when engine-mounted hydraulic pumps are used.

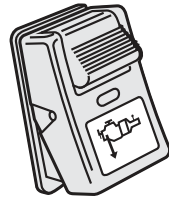

J3015780



J3015781

**Clutch-independent PTO**

Non clutch-dependent power take-off can be engaged or disengaged while travelling without depressing the clutch. Do not switch in the power take-off at engine speeds exceeding 1200 rpm.

Non clutch-dependent power take-off can be used during driving and when the gearbox is not engaged.

Non clutch-dependent power take-off can be engaged or disengaged while travelling without depressing the clutch. Do not switch in the power take-off at engine speeds exceeding 1000 rpm.



J0008084

Non clutch-dependent power take-off can be used during driving and when the gearbox is not engaged.

## Engage power take-off

- 1 Push in the locking button on the switch.
- 2 Press in the lower part of the switch.

The Indicator lamp lights up and the display shows PTO.

## Disengage power take-off

Push in the upper part of the switch.

## Gearbox-mounted power take-off

The vehicle should remain stationary when the power take-off is engaged.

The power take-off should not be engaged during driving. If for some reason it must be engaged, then gearshifting is not allowed.



J0008081

## Engage power take-off

- 1 Depress the clutch pedal.
- 2 Engage a low forward gear.
- 3 Put the gear lever in neutral.
- 4 Push in the locking button on the switch.
- 5 Press in the lower part of the switch.  
The Indicator lamp lights up and the display shows PTO.



J0008082

- 6 Release the clutch pedal.

## Disengage power take-off

- 1 Depress the clutch pedal.
- 2 Push in the upper part of the switch.
- 3 Release the clutch pedal.

The vehicle should remain stationary when the power take-off is engaged.

The power take-off should not be engaged during driving. If for some reason it must be engaged, then gearshifting is not allowed.

On trucks with I-shift it will not be possible to change gear if the power take-off is engaged while driving.

The desired gear must be selected while the truck is stationary.

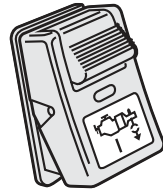

J0008081

## Engage power take-off

It does not matter which position the gear shifter is in.

- 1 Hold in the lock button on the switch
- 2 Press in the lower part of the switch  
The indicator lamp lights and the display shows PTO.



J0008082

## Disengage power take-off

Press in the upper part of the switch.

When the gearbox is in neutral it is possible to choose between two gears, N1 and N2, with different speed ranges.

- 1 Move the gear lever to N
- 2 Select N1 or N2 with the +/- button
- 3 See which gear is selected on the display

N2 allows about 30% higher engine speed than N1.

## High range lock-up

High range lock-up is used when a PTO is installed in the powertrain. The gearbox will start in high gear when the vehicle is disengaged from the engine and gearbox and the powertrain PTO is engaged. Lock-up will already be active at low engine speed.

## Engage

- 1 The engine must be idling at low speed
- 2 Move the gear lever to N

- 3 Apply the parking brake
- 4 Engage the PTO in the powertrain
- 5 Wait until HS is shown on the display (High range lock-up Standby)
- 6 Move the gear lever to position A (or M)
- 7 Wait until HR is shown on the display (High range lock-up Running)
- 8 Increase engine speed to the desired rpm.
- 9 The C will disappear when the engine speed is increased (the rpm depends on whether the gear lever is in A or M)

## **Disengage the powertrain PTO temporarily**

- 1 Move the gear lever to N
- 2 HS is shown on the display (High range lock-up Standby)
- 3 Re-engage by moving the gear lever to position A or M

## **Disengage**

- 1 Lower the engine speed to idling
- 2 Move the gear lever to N
- 3 Apply the parking brake
- 4 Disengage the PTO
- 5 HD is shown on the display (High range lock-up Disengaging)
- 6 Wait until HD is no longer shown on the display
- 7 It is now possible to drive off with the vehicle. If HD remains on the display, it may be due to the parking brake not being applied.

## **Incorrect usage**

If engaging or disengaging is not carried out correctly, HD (High range lock-up Disengaged) will be shown on the display. The gearbox will select neutral. Try one of the following measures:

- Disengage the PTO
- Apply the parking brake
- Move the gear lever to N
- Turn off the engine and restart it

## High range lock-up

(Option)

High range lock-up is used when a power take-off is installed in the drive train. When the gearbox is in neutral (gear selector in N position) and the drive train power take-off is engaged, the gearbox will start in the highest gear. The lock-up clutch locks already at low speeds.

### Engage the drive train power take-off

- 1 The engine must be idling at low speed
- 2 Move the gear shift lever to N
- 3 Apply the parking brake
- 4 Engage the power take-off in the drive train
- 5 Wait until HS is shown in the display (High range lock-up Standby)
- 6 Move the gear shift lever to position A (or M)
- 7 Wait until HR is shown in the display (High range lock-up Running)
- 8 Increase the engine speed to the desired speed
- 9 The C will disappear when the engine speed is increased (the engine speed depends on whether the gear shift lever is in the A or M position)



## **Disengage the drive train power take-off temporarily**

- 1 Move the gear shift lever to N
- 2 HS is shown in the display (High range lock-up Standby)
- 3 Re-engage by moving the gear shift lever to position A or M
- 4 The display shows HR again

## **Disengage the drive train power take-off**

- 1 Reduce the engine speed to idling
- 2 Move the gear shift lever to N
- 3 Apply the parking brake
- 4 Disengage the power take-off
- 5 HD is shown in the display (High range lock-up Disengaging)
- 6 Wait until HD is no longer shown in the display
- 7 It is now possible to drive the vehicle. If HD remains in the display, it may be due to the parking brake not being applied.

## **Incorrect usage**

If engaging and disengaging is not done correctly, an H is shown in the display. The gearbox selects neutral. Try one of the following measures:

- Apply the parking brake
- Move the gear shift lever to N
- Disengage the power take-off
- Turn off the engine and restart it

## **Tying down the truck on a ferry**

When the vehicle is to be lashed for ferry transport, the air bellows must first be completely emptied and then the air suspension system shut off.

1 Apply the parking brake.

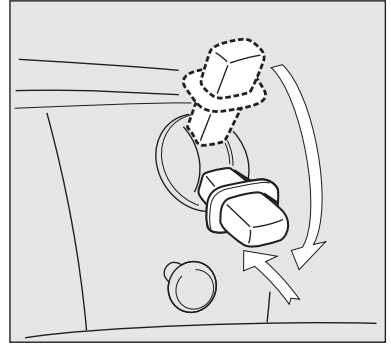

J5012418

2 Select manual control.

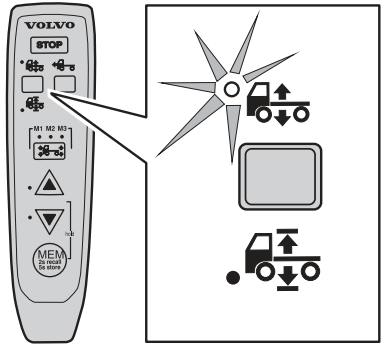

J7009823

3 Select M2

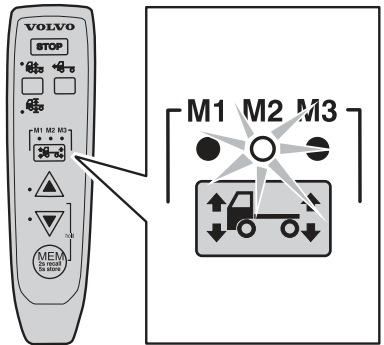

J7009824

4 Lower the truck to it's lowest level.

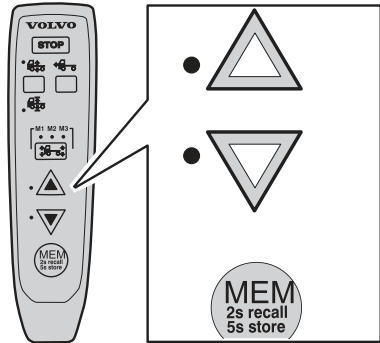

J6009620

5 Press and hold in the lower part of the adjustment button. Then press the memory button without releasing the adjustment button. When the LED lights, release the lower adjustment button first. Wait five seconds and then release the memory button.

When the button is released the remaining air drains out of the bellows.

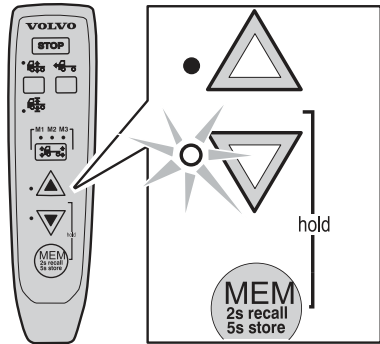

J6009619

6 When all the air is drained and there is no more hissing, turn the starter key to the stop position.

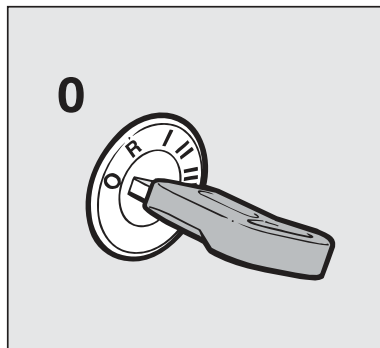

J7008413

## 7 Select ride height.

The truck is ready for tying down and the air suspension system is turned off.

The truck automatically assumes driving height when the ignition is turned on and the parking brake is released.

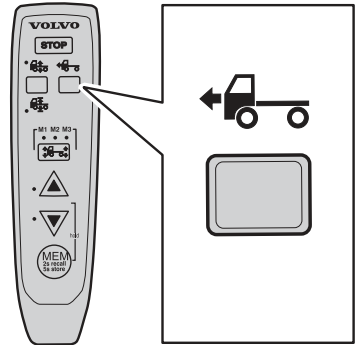

J7009822

When the vehicle is to be lashed for ferry transport, the air bellows must first be completely emptied and then the air suspension system shut off.

## 1 Apply the parking brake.

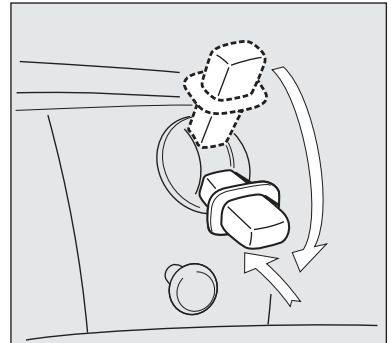

## 2 Select manual control.

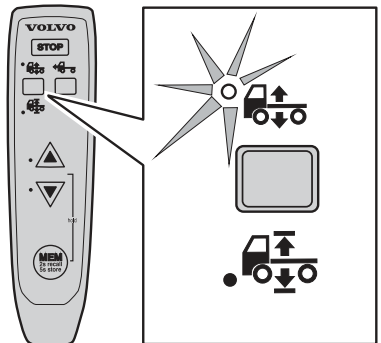

3 Lower the truck to it's lowest level.

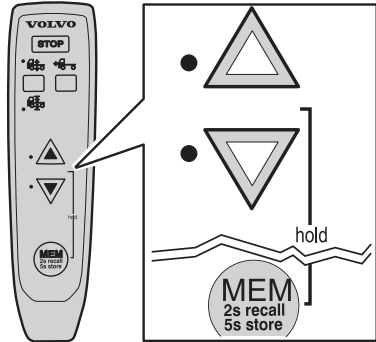

4 Press and hold in the lower part of the adjustment button. Then press the memory button without releasing the adjustment button. When the LED lights, release the lower adjustment button first. Wait five seconds and then release the memory button. When the button is released the remaining air drains out of the bellows.

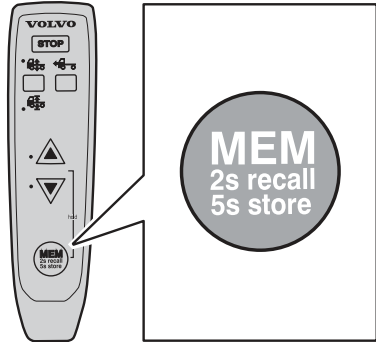

5 When all the air is drained and there is no more hissing, turn the starter key to the stop position.

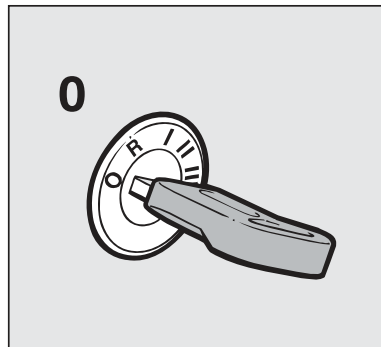

**6 Select ride height.**

The truck is ready for tying down and the air suspension system is turned off.

The truck automatically assumes driving height when the ignition is turned on and the parking brake is released.

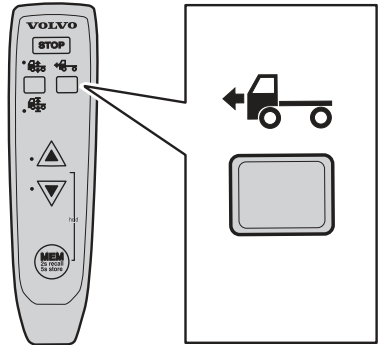

**Ride height memory**

The height of the chassis above ground when driving can be adjusted within certain limits. The range of adjustment is dependant on the type of vehicle and on some trucks it cannot be adjusted at all.

It is always possible to restore the ride height factory settings.

Road speed must be lower than 30 km/h when the control box is used.

**Note!**

If the ride height is changed it can effect the driving characteristics negatively.

**Adjusting ride height**

**1 Select adjustment of ride height.**

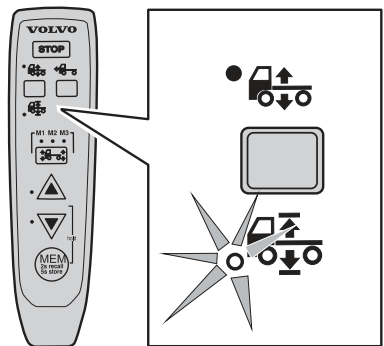

# 188 Driving

2 Use the axle switch to select the axle to be adjusted:

- M1 for the front axle.
- M2 for both front and rear axles.
- M3 for rear axle.

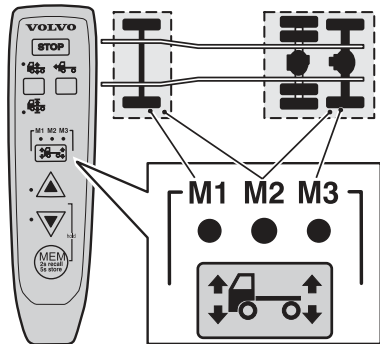

J7009818

3 Set the height you want with the height buttons.

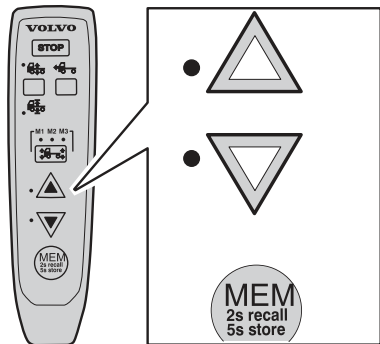

J6009620

4 Keep the memory button depressed for at least five seconds.

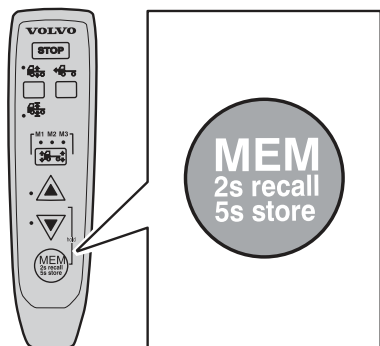

J7009820

5 The new ride height is now set. Select ride height.

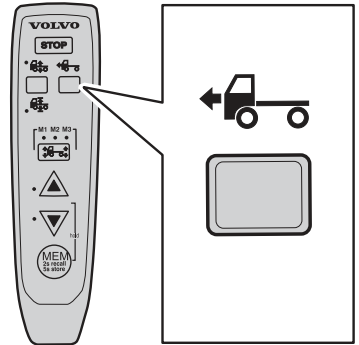

J7009822

1 Select adjustment of ride height.

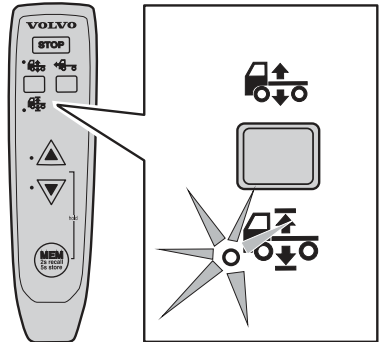

J7009833

2 Set the height you want with the height buttons.

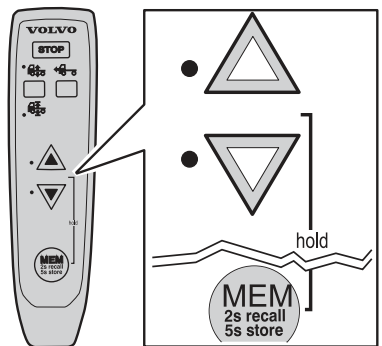

J7009831



# 190 Driving

3 Keep the memory button depressed for at least five seconds.

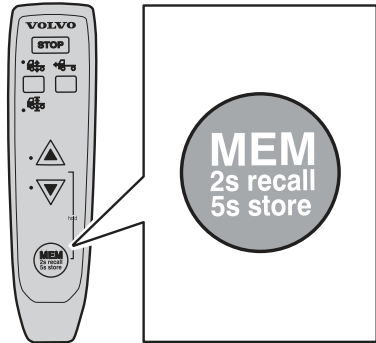

J7009832

4 The new ride height is now set. Select ride height.

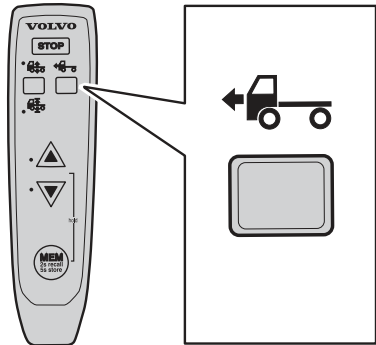

J7009834

## Restoring the factory-set ride height

It is always possible to restore the ride height the truck had from the factory.

Road speed must be lower than 30 km/h when the control box is used.

1 Select adjustment of ride height.

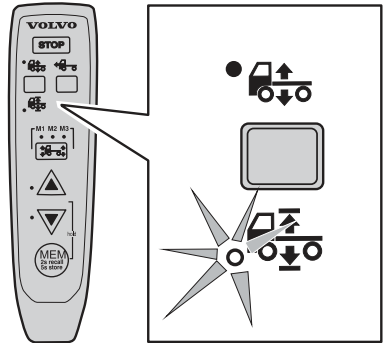

J7009821

2 Keep the memory button depressed for two seconds.

3 Release the button.

The truck returns to factory set ride height.

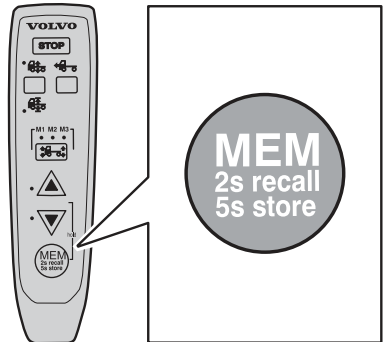

J7009820

4 Select ride height.

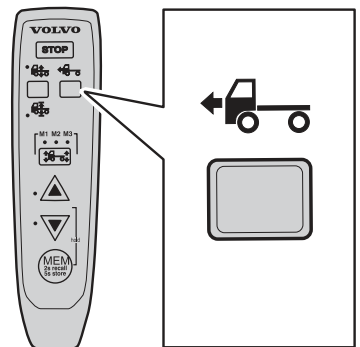

J7009822

# 192 Driving

1 Select adjustment of ride height.

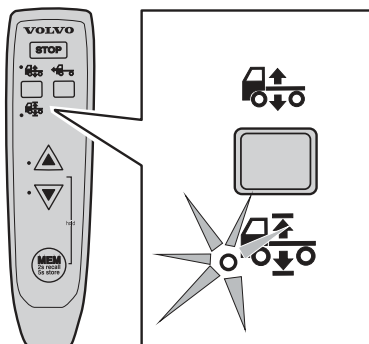

J7009833

2 Keep the memory button depressed for two seconds.

3 Release the button.

The truck returns to factory set ride height.

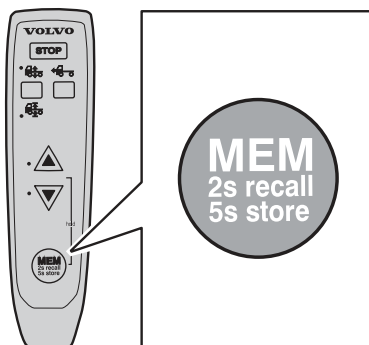

J7009832

4 Select ride height.

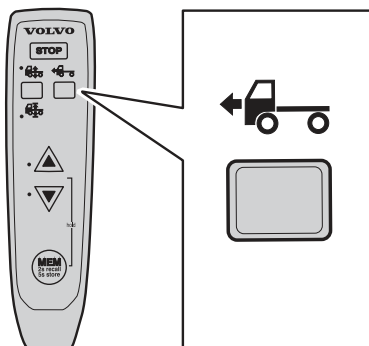

J7009834

## General

A ADR adapted trucks shall be able to transport dangerous goods in such a way, that they do not cause or aggravate any accident.

ADR regulations differ from country to country, but they are all based on ADR regulations. Follow each respective country's regulations.

The ADRtruck's main switch disconnects power to all systems and trailer(s) except the tachograph.



### Caution!

Turn off the parking heater before disconnecting power. Otherwise the parking heater may be damaged if it is turned on when power is disconnected.

### Note!

Do not bypass the switch for any system. If the switch is bypassed for any system, the truck no longer fulfills the legal requirements and safety demands.

## Turn off the power

Press in the switch on the dashboard

or

Press in the switch on the cab backpanel (extra equipment)

When the ignition key is removed from the ignition lock, power is disconnected firstly after 20minutes. If the parking lights, parking heater or hazard warning lights are on or if the air suspension is active (control button not in drive position) then the power is not disconnected.

When the main switch is turned off, all systems in the truck are switched off except the tachograph.

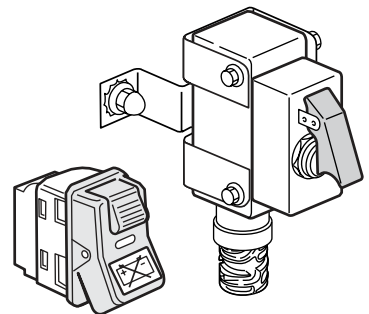

J0010215

 **Warning!**

Do not turn off the power when travelling! When the main switch is turned off, the engine and other important systems are turned off.

## Turn on the main switch

Operate both emergency switches

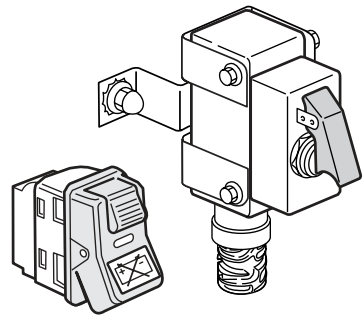

J0010215

Turn the ignition key to at least the radio position

In order to have power when resting or overnighting, the key must be in the ignition lock in one of its positions. The key must have been in the radio position first.

If the parking lights, parking heater or hazard warning lights are on or if the air suspension is active (control button not in drive position) then the power is not disconnected, even if the key is removed.

If the ignition key is already in radio position, power will be restored when the emergency switch is reset.

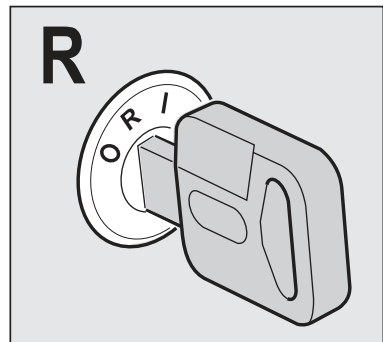

J0010213

## Turn on power for 20 minutes

Both emergency switched must be on.

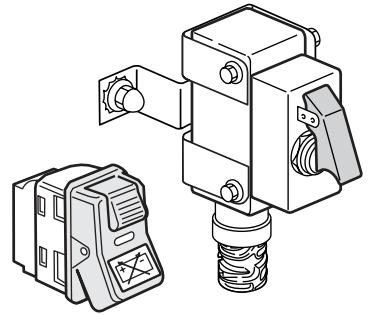

J0010215

There are two ways to turn on power for 20 minutes:

**1**

- First turn the ignition key to the radio position.
- Then turn the ignition key to the stop position.
- Finally remove the ignition key from the lock

The main power is disconnected after 20 minutes.

If the parking lights, parking heater or hazard warning lights are on or if the air suspension is active (control button not in drive position) then the power is not disconnected.

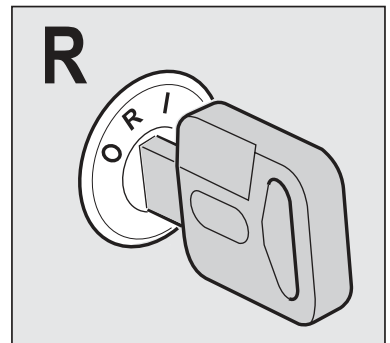

J0010213

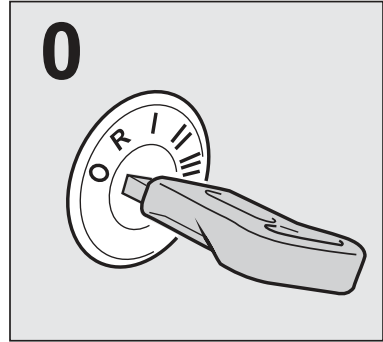

J0010282

- 2**  
Hold the ignition lock in for 2 seconds  
The main power is disconnected after 20 minutes.  
If the parking lights, parking heater or hazard warning lights are on or if the air suspension is active (control button not in drive position) then the power is not disconnected.

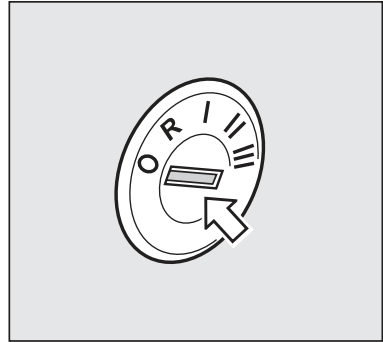

J0010214

## General

ACC (Adaptive Cruise Control, adaptive cruise control) is an extension of the cruise control that allows automatic speed/distance adjustment, based on the vehicle in front of the truck.

ACC should primarily be used in open road situations. Avoid use in heavy traffic and on long down hill inclines when catching up slow moving vehicles.

### Note!

ACC does not replace the driver! The driver has the final responsibility for ensuring that a safe distance is maintained to the vehicle in front.

### Note!

Do not fit anything in front of the sensor (for example, spotlights). The sensor will not function.



### Caution!

Do not use ACC in hilly terrain, heavy traffic or on slippery surfaces.



### Caution!

ACC can have difficulty identifying vehicles that are displaced sideways, so the vehicle may brake unexpectedly when overtaking. It is therefore recommend to use the accelerator to manually increase speed when overtaking, or to disengage ACC.



**Caution!**

ACC does not brake for stationary obstacles or very slow moving vehicles.

## Engaging ACC

The control (3) for the cruise control is placed in the direction indicator stalk.

- 1 Make sure that the auxiliary brake stalk is in position A
- 2 Set the switch (3) to the ON position
- 3 When the required speed is reached, press SET (1)  
The desired speed is obtained by using the accelerator pedal as usual and then pressing + or - on SET (1).

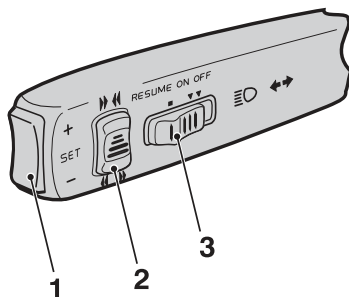

J2021178

If the cruise control (CC) is active, ACC is engaged by moving the auxiliary brake stalk to position A.

When the cruise control is engaged, the display shows “ACC”.

The cruise control cannot be engaged at low speeds. See section “Cruise control” for more information.

### **Note!**

If the retarder stalk is in positions 0, 1, 2 or 3, only normal cruise control is engaged. In these positions there will be no automatic speed/distance adjustment, based on the vehicle in front of the truck.

### **Note!**

Do not use ACC on slippery surfaces.

## Disengage ACC

The cruise control is disengaged by:

- depressing the brake pedal,
- moving the control (3) to “OFF”, or
- moving the retarder stalk to any other position than A.

The previously set speed is retained in the memory. It can be resumed by moving the control (3) to “RESUME”. A temporary increase of speed, e.g. when overtaking, does not interfere with the cruise control's function.

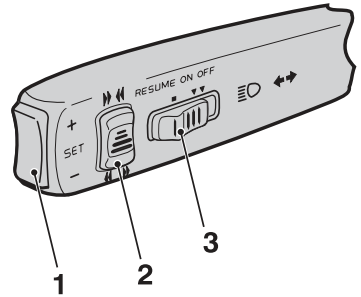

J2021178

## Inactivate ACC

By switching off the traction control via the “Vehicle settings” menu in the display, the ACC is inactivated at the same time. Inactivation of ACC is suitable when the truck is on rollers, for example dynatests, authority tests, vehicle inspections or similar.

To re-engage ACC the truck must be restarted.

For more information about traction control, see “Driver's manual EBS”.

## Change speed

Change the preset speed by short presses on + or – on SET (1). The preset speed can also be changed by using the accelerator pedal and SET (1).

The set speed in ACC is shown by a green LED alongside the corresponding speed in the speedometer. The set speed is shown in intervals of 5 km/h. In the figure, the speed is set between 73 and 77 km/h.

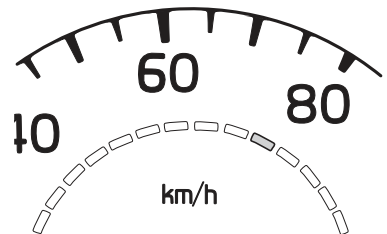

J2015658

## Change the time gap

Move the control (2) upwards to reduce the time gap and downwards to increase the time gap.

When the control (2) is moved, the current time gap is shown in the display for a short while (see figure on right). In the example shown, the next longest of the five time gaps has been selected.

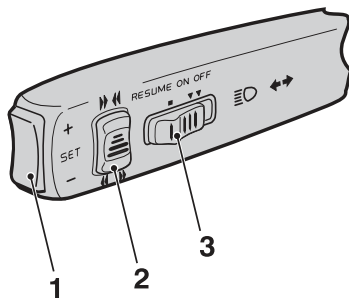

J2021178

11:45
AM
ACC
7658.8 km

### Note!

The lines indicates the current distance. Five lines is the maximum.

### Note!

Whenever the truck is started, the third time gap is automatically selected.

### Note!

The actual distance will vary depending on the speed of the truck.

## When the truck itself adjusts the speed

### A vehicle is detected in front of the truck

When ACC detects a vehicle, a green symbol lights in the instrument.



J2015657

A green symbol in the instrument shows that ACC has detected a vehicle

### The speed is adapted to the vehicle in front

If the vehicle in front is driving slower than your own truck's ACC setting, the speed difference is shown with yellow LEDs on the speedometer.

The ACC will only use the auxiliary brakes to reduce your speed to the same speed as the vehicle in front, once your truck has come sufficiently close to it. In other words, the truck may not start braking as soon as the symbol appears in the instrument or the speedometer LEDs light.

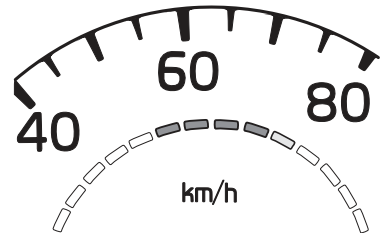

J2015659

Yellow diodes show the difference in speed between the vehicle in front and the truck.

### If the vehicle in front disappears out of sight

If the vehicle in front disappears out of sight of the ACC, e.g if the vehicle changes lanes, increases speed or turns off the road, the symbol will go out and the truck will accelerate to the set speed again.

On a bend, a vehicle in front can temporarily disappear from the field of vision of the ACC. As long as the ACC senses that the truck is on a bend, it maintains the same speed as before the vehicle disappeared from the field of vision.

### When the vehicle must be braked manually

If the truck catches up with a vehicle that is travelling so slowly that ACC cannot manage to brake sufficiently, a collision warning occurs: the symbol in the instrument lights up and all the LEDs in the speedometer turn red. At the same time, a signal is sounded. Use the footbrake to reduce the speed sufficiently!



J2015657

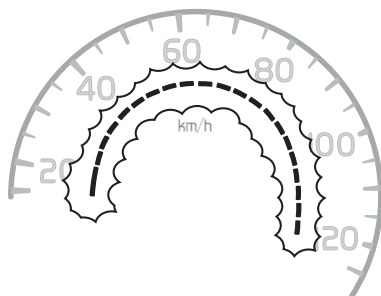

J2021188



#### Caution!

The ACC may identify a vehicle that is very **close** to the identification area, e.g. in an adjacent lane. This may result in unexpected braking of your truck.

### Brake protection

To protect the wheel brakes from over-use, there is a built-in protection which limits the use of the wheel brakes. ACC then temporarily changes to reduced capacity.

The “ACC reduced” symbol informs that ACC has changed to only use the auxiliary brakes and that the braking capacity for ACC is reduced.

#### Note!

If the connected trailer has no ABS or has a faulty ABS, the system goes to reduced capacity.



J203149

When ACC is permitted to use the wheel brakes again, the symbols to the right are shown:

How long time it takes until ACC permits the use of the wheel brakes again depends among other things on how much the driver uses the footbrake during the time the ACC has reduced the brake capacity.

If the brake protection is activated at the same time as the ACC brakes for a slower vehicle, the system will warn the driver (compare with collision warning). Thereafter the system temporarily goes over to reduced ACC.



When ACC is in the reduced mode, the ACC has reduced braking capacity.

## Note!

Economic use of ACC on downhill slopes behind slower vehicles reduces the risk of the brake protection being activated and that ACC goes to reduced mode.

## Driving at low speed

When driving at very low speeds, ACC is automatically disengaged. The symbol to the right is then shown. See chapter "Cruise control" for more information.

E.g. this can occur when driving in a slow moving queue.



J203330

### If the ACC does not work

ACC will not function while the radar sensor is warming up in low temperatures, or if it is very dirty or covered with snow or ice.

### Heavy vehicles

ACC will not function if the braking system (EBS) has not managed to calculate the total weight of the load after starting.

#### **Note!**

A few short brake stops will speed up the calculation.

### When it is too cold

Wait until the sensor warms up and the symbol goes out.



J2021177

### When the sensor is dirty

Clean the front of the radar sensor. The radar sensor is located in a recess on the left side of the lower front of the truck.



J2021176

### Calibration

When the truck is started, calibration is performed on the ACC. Calibration only takes a few seconds.

#### **Note!**

Wait until the ACC is calibrated before driving away.

## Powertronic, general

Powertronic is a fully automatic gearbox that changes gear without any interruption in the power transfer. It has a torque converter with a lock-up clutch working with all gears. The gearbox can be fitted with a retarder and a power take-off that can be engaged and connected while driving. The gear shifter is mounted on the seat.

## Gear shifter

The gear shifter is fixed to the seat and the gear shift lever can be tilted to allow the driver to move freely around the cab without being hindered by the lever.

## Gear shift lever

On the side of the gear shift lever facing the driver's seat, is a +/- button (A) with spring-loaded up and down positions and a neutral position in the middle. On the top is a button (B) that is used to tilt the gear shift lever to the horizontal position. There is also a lock (C) on the front of the gear shift lever to prevent unintentional gear engagement. The lock must be pressed in for the following gear changes:

- from N to R
- from N to any of the forward gears

The lock does not need to be pressed when the gear shift lever is moved from A to M.

The gear shift lever can always be moved to N without having to press a button.

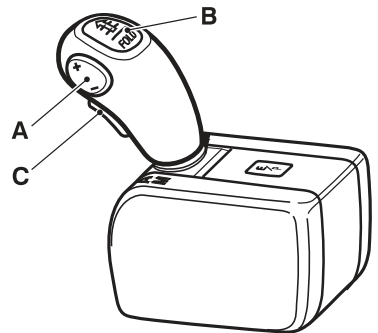

J4020107

## Gear shift lever positions

Two different programs for driving forward plus neutral or reverse can be selected with the gear shifter.

**R** Reverse. Gear changing is done with the +/- button on the gear shift lever.

**N** Neutral. No gear engaged.

**A** Automatic program.

### Note!

The engine can only be started with the gear shifter in position N.



**M** Manual program. Changing up and down is done using the +/- button on the gear shift lever.

**F** Tilted position.

## Tilting the gear shift lever

The gear shift lever can be tilted to horizontal position to allow easy movement between the driver's seat and other parts of the cab.

To tilt the gear shift lever:

- Make sure the gear shift lever is in neutral position N.
- Press in the button on top of the gear shift lever and tilt the lever forwards, past the reverse position R, to the horizontal position.

To raise the gear shift lever for driving:

- Move the gear shift lever upwards, past the reverse position R, until it locks in neutral N.

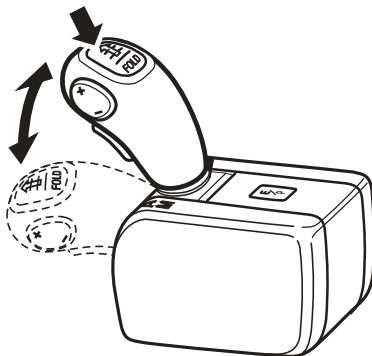

J4020111

## Buttons

### Changing up/down

The +/- button is used to:

- change up or down, one or more gear change steps at a time in manual mode
- to select reverse gear
- select start gear in automatic mode or pre-selection of gear 1 while driving

### Economy/Power (E/P)

There is an economy/power (E/P) button on the top of the gear shifter which is used for changing between the economy and power programs.

## Display

Select the GAUGES menu from the display to view information on Powertronic (applies to both a stationary vehicle and one in motion). The display provides information on the gear currently selected and which gears are available.

See “Driver Instruction Display” for information about how to set information about the gearbox as favourite display.

The gearbox section in the display is divided into smaller sections showing:

- 1 Drive program
- 2 Current gear
- 3 Available gears (up/down)
- 4 Lever position

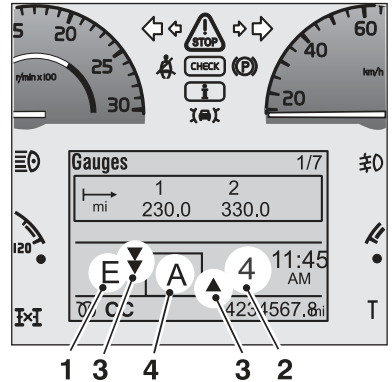

J3018211

### 1. Driving program

The section to the far left of the display shows the driving program. The following programs are available:

- E = economy
- P = power
- B = brake program (requires VEB/VEB+ or retarder)
- K = kick-down
- L = Limp home
- 1 = start in 1st forward and 1st reverse  
(see “Selecting starting gear”)
- Z = engine speed too high to move from neutral
- HR = High Range lock-up (option)

### 2. Current gear

The section to the right shows the current gear and if the torque converter is engaged.

- Forward gear no. 1–6
- Reverse gear no. 1–2
- C = converter (torque converter)
- EN = Emergency Neutral

SN = Safety Neutral

When “EN” is shown in the display, an electronic fault has been indicated on one or more solenoid valves which can cause damage to the gearbox. Gears that are not affected can still be used. To engage a gear that is higher than the damaged gear, the vehicle must be accelerated to a faster speed so that the gearbox can skip a gear. Use manual gear changing. Contact a Volvo workshop.

When “SN” is shown in the display, the gearbox main pressure is too low to be able to leave N. If “SN” is shown when the gearbox is cold, run it warm in N and try to engage the gear again.

### 3. Available gears

To the left of the lever position section is a section with arrows showing the number of lower gears that are available. To the right of the lever position section is a section showing, in the same way, the number of higher gears that are available.

The gearbox must be in manual mode in order to utilize the available gears.

The gears are selected by the +/- button.

### 4. Lever position

The section in the middle of the display shows the gear shifter's position.

A = Automatic

M = Manual gear changing

N = Neutral

R = Reverse gear

A flashing A, M, N or R indicates that Autoneutral (option) is engaged. The gearbox is in neutral but the gear shift lever is in drive position.

## Driving programs

Driving programs E and P are used only for automatic gear changing when the gear shifter is in position A.

**E** The economy program gives lower fuel consumption.

**P** The power program is used when power has priority over fuel consumption. Up- and down-changing is done at higher engine speeds.

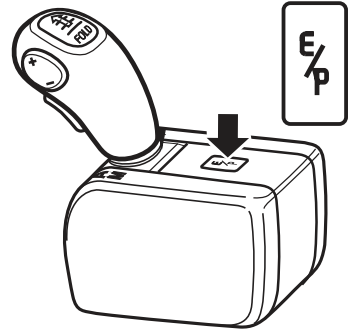

J4020109

## Automatic gear changing

Gear changing is completely automatic in position A. When reversing (R), gear changing is done manually.

If the gear shift lever is moved to M when driving with the automatic program A changing will be inhibited and the current gear will remain engaged through the entire engine operating range.

If, while driving you want to make sure that 1st gear will be used, e.g. on steep hills or with high rolling resistance, the gear can be pre-selected. Pre-selection means that down-changing, when necessary, is done at an optimum engine speed, without the driver being aware of it. Down-changing is done when the right speed has been reached.

To pre-select 1st gear, press once on the minus button while driving. Pre-selection of 1st can only be done at speeds below 50 km/h. 1st remains as selected until the driver presses +. When the speed exceeds 50 km/h, it returns to automatic selection between 1 and 2 gears.

## Kickdown

Kickdown is activated by fully depressing the accelerator pedal (position B). The kickdown program optimises gear selection/throttle for maximum acceleration which most often leads to down-changing. Kickdown functions in both the economy and power programs, but not in manual mode.

Position A = full throttle

Position B = kickdown

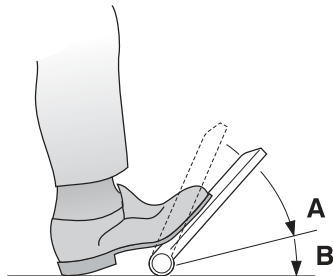

J2012347

## Manual gear changing

Gear change is done manually using the button on the gear shift lever. Change up with + and down with -. The change occurs when the button is released. If the engine speed gets too high or too low, the control unit will change gear automatically. The lock-up clutch, “Lock-up” can not be affected manually.

## Select starting gear

Selection of starting gear is done automatically after driving a short while. Starting gear (1 or 2) can be selected manually using the +/- buttons on the gear shift lever. If 1st gear is selected a 1 is shown after E or P in the left section of the display. If 2nd is selected as the starting gear, no digit is shown in the display.

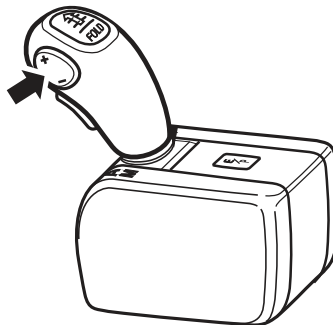

J4020108

## Select 1st as starting gear

The truck starts in 1st gear when driving forward and in R1 when reversing.

### When the vehicle is stationary

- Set the gear shift lever to A or N
- Press –

## Select 2nd as starting gear

The truck starts in 2nd when driving forward and in R2 when reversing.

### When the vehicle is stationary

- Set the gear shift lever to A or N
- Press +

## Autoneutral

(Option)

The Autoneutral function puts the gearbox in neutral position without the gear shift lever having to be moved to the N position. Autoneutral can be activated by the parking brake, the service brakes or by a signal from the bodywork construction. When Autoneutral puts the gearbox in neutral, A, M or R flashes. What activates Autoneutral is decided by the body builder.

## Brake interlock

(Option)

The “brake interlock” function prevents the command when the gear shift lever is moved from N to A, M or R which can allow the truck to roll away by mistake. To drive away, the foot brake must be depressed before the gear shift lever is moved from N to A, M or R.

## Dual driver stations

(Option)

On vehicles with dual driver stations, the gear shift lever in the ordinary driver position must be in N, neutral, to be able to drive from the second driver position.

## Auxiliary brakes

The auxiliary brakes also work in reverse.

## Actions with gearbox malfunction

An “L” in the display indicates that two of three datalinks to the engine are open circuit. The Powertronic system then activates Limp home. This function makes it possible to drive short distances, with a fault in the vehicle, for example to the nearest service workshop.

When Limp home is activated, only manual gear changing is possible. When the gear shift lever is in position M or R, the driver can change gear using the +/- button.

Power take-offs are shut off automatically when Limp home is activated. It is possible to re-engage it as long as the engine speed is kept below 1000 rpm. All special functions on the vehicle will be terminated and cannot be activated.

Limp home will be disengaged automatically once the fault has been rectified.

### **Note!**

The accelerator pedal must be released before changing gear so that the engine torque is reduced. This also applies when engaging the lock-up function.

### **Note!**

The auxiliary brakes must be turned off when changing down.

## Reversing with loads

When reversing down steep inclines with a loaded vehicle at low speed, there is a risk that the front wheels lock if the service brake is used for regulating the speed. By using the engine and torque converter, the driving wheels can be braked instead. Use the

forward gears 1 or 2 depending on the inclination and brake at low speeds by applying throttle. When reversing at higher speeds and engine speeds with the gear shift lever in R, the retarder and/or the engine brake gives sufficient braking effect.

## Rocking free

On slippery surfaces e.g. snow or sand, the truck can be rocked free by carefully pressing down and releasing the accelerator pedal. You then gradually extend the wheel tracks you have got stuck in.

- 1 Make sure the differential locks are completely engaged
- 2 Move the gear shift lever to M, gear 1
- 3 Carefully press down the accelerator pedal with an even pumping action

If you want to rock by quickly changing between forward and reverse, this can be done at low engine speeds (less than 1100 rpm) and at a max speed of 5 km/h.

## Marshalling

When marshalling, it may be necessary to increase the engine speed to drive e.g. steering servo and hydraulic pumps. You can then throttle and brake at the same time, the engine speed is increased and you can regulate the speed with the brake pedal. Use the lowest gear. Make sure the brakes do not overheat.

## Idling speed

If the vehicle is to stand still with a gear engaged, the service brakes or parking brake must be used. To reduce the driving and the braking power required, the engine idling speed can be reduced to 550 rpm for D11. D13 is preset at 500 rpm and cannot be reduced any lower. For information about how idling speed is reduced, see "Driver's Manual".



## Oil temperature

Normal working temperature for the gearbox is approx. 80–95 °C. When driving at full throttle for long periods with the torque converter working, the oil temperature may rise and result in overheating.

Continuous retarder operation will also have this effect. If the oil temperature becomes too high in operation, the yellow warning lamp will light and the associated symbol will be shown in the display. If the yellow warning lamp lights while the retarder is engaged, the retarder's braking effect is reduced. If the temperature rises more, the red stop lamp will light and the retarder will be turned off to protect the gearbox.

Slow down when the yellow warning lamp comes on and engage a lower gear until the gearbox has returned to its normal operating temperature.

If the oil temperature becomes too high in normal operation, check the oil level in the gearbox and replace the filter.



## Retarder temperature

If the temperature in the retarder exceeds 140 °C, the yellow warning lamp will light and a symbol will be shown in the display. The retarder braking effect is reduced. If the temperature rises more, the red stop lamp will light and the retarder will be turned off to protect the gearbox.

Slow down when the yellow warning lamp comes on and engage a lower gear until the gearbox has returned to its normal operating temperature.



## Oil pressure

The symbol is shown when the required oil pressure cannot be reached.

The symbol is shown together with a white information lamp when the gearbox main pressure is low to allow the engine's maximum torque. The vehicle can still be driven, but the engine torque is limited. Contact a Volvo workshop. If the symbol is shown together with a red warning lamp, stop immediately and investigate the fault.



## Oil filter

The symbol is shown when the oil filter is clogged. The symbol is shown together with a yellow warning lamp. Contact a Volvo workshop for filter change and fault tracing.



## Checking the oil level

Oil grade: **Volvo Transmission oil 97342.**

Check of the oil level must be done with the oil temperature at 80–95 °C to ensure the correct oil level.

- 1 Clean round the oil filler cap and dipstick.
- 2 Park on a level surface, apply the parking brake and start the engine.
- 3 Put the gear selector in N with the engine running at approximately 600 rpm.
- 4 Wipe the dipstick with clean, lint-free paper.
- 5 Check the oil level on the dipstick, The level should be between the markings on the dipstick. Top up as necessary with oil of the right grade. If the oil level is too high it may cause a high oil temperature in the gearbox.

**Pay attention to the purity of the oil!**

### Showing the oil level in the display

The current oil level for the gearbox can be shown in the information display. The difference between max. and min. is 3 litres. The below conditions must be fulfilled for a value to be shown.

- The engine must have been running for at least 1 minute
- The transmission oil temperature must be 80–90 °C
- The engine speed must be 550–650 rpm
- The truck must be stationary and on a level surface
- The gear shifter in the N position

If any of these conditions are not fulfilled, a message is shown in the display.

## I-shift, general

I-shift is an automatic gearbox with 12 forward gears and 4 reverse gears. The clutch and gear shifting are operated fully automatically so that the driver can concentrate on the traffic. If necessary, the driver can choose to change gear manually. The gear lever, mounted on the driver's seat, can be tilted horizontal to the seat cushion. Tilting the selector will make it easier for the driver to move around in the cab.

## Gear selector

The gear selector is fixed to the seat and the gear selector can be tilted to allow the driver to move freely around the cab without being hindered by the selector.

## Gear lever

On the side of the gear lever facing the driver's seat, there is a +/- button (A) with spring-loaded up and down positions and a neutral position in the middle. On the top is a button (B) that is used to tilt the gear selector to horizontal position. On the front there is also a gear lever stop (C) to prevent unintentional gear engagement. The lock must be pressed in for the following gear shifts:

- from N to R.
- from N to any of the forward gears.

The lock does not need to be pressed when the gear selector is moved from A to M.

The gear selector can always be moved to N without having to press a button.



J4020428

## Gear selector positions

The gear selector is used to choose between four different driving programs.

- R** Reverse. The truck must be stationary when selecting R.
- N** Neutral position. No gear engaged.
- A** Automatic programme. The gearbox will automatically select the correct gear with respect to load, incline, speed and throttle.
- M** Manual program. Changing up and down is done with the +/- button on the gear lever.
- F** Tilted.

## Tilting the gear selector

The gear lever can be tilted to horizontal position to allow easy movement between the driver's seat and other parts of the cab.

To tilt the selector:

- Make sure the selector is in neutral position N
- Press in the button on top of the gear lever and tilt the lever forwards, past the reverse position R, to the horizontal position

To raise the selector for driving:

- Move the selector up, past the reverse position R, until it locks in neutral N



J4020429

## Buttons

### Changing up/down

The +/- button is used to:

- change up or down one step at a time during manual gear changing
- adjusting gears in automatic mode
- to select split gear in neutral position when using a power take-off
- selecting reverse gear
- selection of starting gear in automatic mode



J4020430

### Economy/Power (E/P)

There is an economy/power button (E/P) on top of the gear selector. This is used to:

- switch between the economy program and the power program



J4020431

## Limp-Home (L)

L is use to activate limp home.



J4020432

## Display

Select the GAUGES menu in the display to view information on I-shift (applies to both a stationary vehicle and one in motion). Information on the gearbox is shown on the driver display.

See "Driver Instruction Display" for information about how to set information about the gearbox as favourite display.

The gearbox section is divided into smaller sections showing:

- 1 Driving program
- 2 Selected gear
- 3 Available gears (down/up)
- 4 Lever position

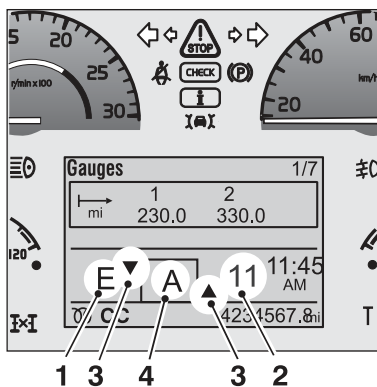

J3018210

### 1. Driving program

The section to the left of the display shows the current driving programme. The following driving programmes are available:

E = economy

E+ = freewheel possible

P = power  
B = braking  
L = Limp-Home function

When the lever is tilted, the programme packet the gearbox is equipped with is shown:

B = Basic  
DC = Distribution and Construction  
FE = Long Haul Fuel and Economy  
HD = Heavy Duty GCM Control

The section to the left of the display shows the current driving programme. The following driving programmes are available:

E = economy  
P = power  
B = braking  
L = Limp-Home function

When the lever is tilted, the programme packet the gearbox is equipped with is shown:

B = Basic  
DC = Distribution and Construction  
FE = Long Haul Fuel and Economy  
HD = Heavy Duty GCM Control

The section to the left of the display shows the current driving programme. The following driving programmes are available:

E = economy  
P = power  
L = Limp-Home function

When the lever is tilted, the programme packet the gearbox is equipped with is shown:

B = Basic  
DC = Distribution and Construction  
FE = Long Haul Fuel and Economy  
HD = Heavy Duty GCM Control

## 2. Selected gear

The section to the right of the gearbox field shows the selected gear.

Gears 1 – 12



N = neutral (N1 = low split, N2 = high split)

R = reverse

### 3. Available gears

The section second from the left of the display shows with arrows the number of lower gears (half steps) that are available (maximum 3 arrows). The section second from the right of the display shows how many higher gears are available in the same way (maximum 3 arrows).

### 4. Lever position

The section in the middle of the display shows the gear selector position.

R = reverse

N = neutral

A = automatic

M = manual

## Program packages

Gearboxes have different characteristics and functions depending on the program package that is installed.

The following program packages are available:

- **Basic** is the standard program for the gearbox
- **Distribution & Construction** includes functions that make the truck lighter to maneuver.
- **Long Haul Fuel & Economy** and includes functions that provide improved fuel economy and also make the truck lighter to maneuver.
- **Heavy Duty GCM Control** is intended for heavy trucks. This program also includes functions that help improve fuel consumption and make the truck lighter to maneuver.

## Function description

The gearbox in this truck is fitted with program packet **Basic** and has the following functions.

The gearbox in this truck is fitted with program packet **Distribution & Construction** and has the following functions.

The gearbox in this truck is fitted with program packet **Long Haul Fuel & Economy** and has the following functions.

The gearbox in this truck is fitted with program packet **Heavy Duty GCM Control** and has the following functions.

## Performance Shift

The best way of synchronising the input and output shafts is selected. This gives faster and more comfortable gear changing.

## Basic Shift Strategy

Automatic choice of start gear.

## Basic Gear Shift Adjustment

Enables adjustment of automatically selected gear during engine braking.

## Gearbox Oil Temperature Monitor

A display that shows the gearbox oil temperature and a warning system that informs the driver when the oil temperature is too high.

## EcoRoll

Automatic engagement and disengagement of the freewheel function, with the aim of reducing fuel consumption. When the accelerator pedal is released, the transmission is disconnected so that the vehicle can roll freely, and the engine is brought down to idling speed.

## **Smart Cruise Control**

Only active when the cruise control is engaged. Saves fuel by deactivating the auxiliary brakes under certain conditions. The function improves the cruise control by disengaging the auxiliary brakes when climbing hills.

## **Launch Control**

Permits clutch control at low speeds by using the brake pedal. Allows the engine to idle without slipping the clutch. Regulates engine torque when pulling away to optimize gear changing and avoid high engine speed.

## **Enhanced Shift Strategy**

Works together with ECS and EBS to select the best gear for easy maneuvering in difficult areas or to obtain the maximum effect from the auxiliary brakes.

## **Heavy Duty GCM Control**

Matches up gear change strategy and clutch operation with high total weight (60-180 tonne).

## **Gear Selection Adjustment in Auto including Kickdown**

Enables selection of gears in automatic mode even when the accelerator pedal is depressed. There is also a Kick Down function for maximising the acceleration of the truck.

## **Enhanced Power Take Off Functions**

An optional function which supports Power Take Off operations, e.g. autoneutral and splitbox.

## Automatic shifting

The simplest way to drive the truck is to use the automatic program (position A). Gear changing is automatic and the driver can concentrate on the actual driving.

When changing gear, the system will govern the clutch, gearbox and throttle. The system selects the gear and the point in time for gear changing for optimum driving performance based on accelerator pedal position, truck weight, road inclination, vehicle acceleration, etc.

It is also possible to adjust the gears up or down in automatic mode. The arrows in the display show how many steps it is possible to change up or down.

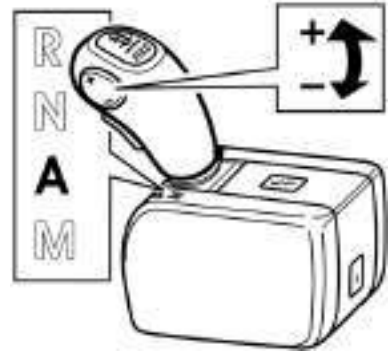

J4020433

### Automatic choice of starting gear.

The gearbox selects the most suitable start gear with respect to weight and the road's gradient.

### Adjusting the starting gear

You can select a starting gear by using the + and - buttons.

## Freewheel (EcoRoll)

The freewheel can be activated if the lever for the auxiliary brake is in position A, and if E+ is shown in the display. When the freewheel is activated, split gear is set to N, neutral. Freewheel is activated differently depending whether the cruise control is active or not.

If the cruise control is active:

- Freewheel is engaged on downward slopes when the speed exceeds the selected driving speed (for example 80 kph). The selected driving speed must be exceeded by 6 kph or more. (See the section on auxiliary brakes for more information as to how the auxiliary brake functions and how the excess speed can be set.)

- Freewheel is engaged when the speed exceeds the selected overspeed or below the set driving speed (for example 80 kph).

If the cruise control is not active:

- Freewheel is engaged when the accelerator pedal is released and the road is flat or slopes gradually downhill.
- The free wheel is disengaged when the brake pedal is depressed, the accelerator is depressed, the lever for the auxiliary brake is set in position 0, 1, 2, 3 or B or if the gear selector is set in position M.

When the free wheel is activated, N is shown as the gear in the info display and the engine idles.

### Locking gear

**This function is used only when driving using the automatic program A**

The function can be used in all forward gears (1 to 12).

Whenever gear changing is not required (e.g. driving up a hill), move the lever from A to M. No further gear changes will be carried out and the current gear will be kept engaged. The display shows an M.

To return to the automatic program, move the selector back to A again.



J4020434

### Note!

There is risk of over revving when the gear is locked.

 **Caution!**

Starting in too high a gear wears the clutch and can increase the risk for clutch breakdown.

## Driving program

### Economy

When the engine is started, the economy program is always selected (shown as an E on the display). The economy program gives priority to fuel economy and is primarily used when driving under normal conditions.

### Performance

The power program is engaged/disengaged using the E/P button (see illustration). The performance program gives priority to driveability and is used when driving in hilly terrain and off-road.



J4020431

### Brakes

A special braking program can be engaged using the auxiliary brake lever. See the section on auxiliary brakes.

## Kick-down

Kick-down is activated by fully depressing the accelerator pedal (position B). The kick-down program optimises gear selection/throttle for maximum acceleration. This is possible in both economy and power programmes but not in the manual position M.

Position A = full throttle

Position B = kick down

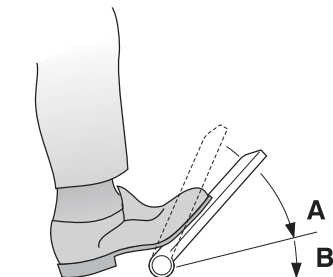

J2012347

## Manual shifting

You can drive the truck with completely manual gear changing or take over from the automatic gear changing system whenever required. Gear changing is done by first moving the lever to the manual position M. The +/- button on the side of the lever is then used to select the gear.

For a new gear, the +/--button should be pressed once for each gear step upwards or downwards, to the desired gear.

Press several times on the +/--button in sequence to shift through several gears at once.

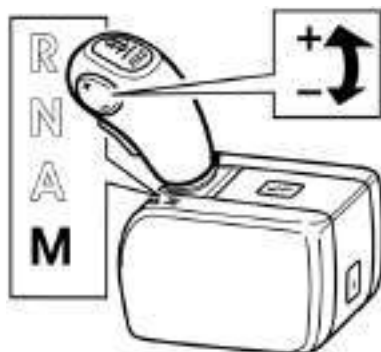

J4020435

### Note!

Do not release the accelerator pedal during gear changing.

**⚠ Caution!**

Starting in too high a gear wears the clutch.

## Reverse gears

The gearbox has four reverse gears (R1 to R4). The truck must be stationary before reverse gear can be engaged. The system will select R1 automatically when the gear lever is moved to R.

When driving, it is possible to shift between gears R1 and R2 and between R3 and R4. To shift gear between R2 and R3 the truck must be stationary.

Manual gear changing is via the +/-button on the gear selector.

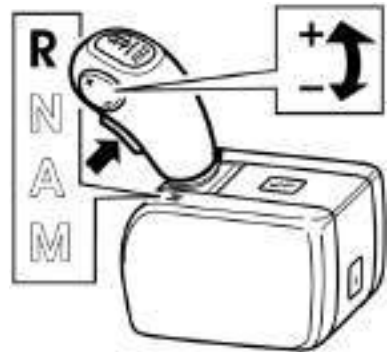

J4020436

**Note!**

The gear selector lock must be pressed in before the gear selector can be moved from N to R.

**⚠ Caution!**

Starting in too high a gear wears the clutch.



## In case of gearbox malfunction

When a fault occurs on the gearbox which means that the vehicle cannot be driven, activate Limp home function and drive on.

Activate Limp home like this:

- 1 Hold in L on the gear selector casing
- 2 Move the gear selector to A  
Limp home is activated
- 3 Move the gear selector to M
- 4 Select gears using the +/- button on the gear selector

When Limp home is selected, it is not possible to drive if the selector is in position A. Only gears 1, 3 and 5 forwards and 1 reverse can be used. Gear shifting is only possible when the truck is stationary.

To select reverse, move the lever to R. Move the lever back to M to resume driving forwards. It is not necessary to press the L button again.

Limp homefunction will be disengaged when the ignition is turned off.



J4020432

### Note!

Limp homefunction should only be used for short distances.

## Starting on hills

- The truck can be kept still using the parking brake or trailer brake.
- Put the gear selector in A
- Depress the accelerator
- Release the brake once the clutch starts to pull



### Caution!

Never hold the vehicle stationary on an upward slope using the accelerator pedal. The clutch could overheat, which could cause it to fail.

## Driving off road

In uncertain or difficult driving conditions, such as forest roads, building sites, or off-road, manual position is preferable.

## Clutch

The clutch is a dry disc type, i.e. has no torque converter. So never pull away in high gears by slipping the clutch. The information lamp will come on and a symbol will appear on the display if the clutch overheats.



J3014466



J3008835



### Caution!

Never hold the vehicle stationary on an upward slope using the accelerator pedal. The clutch could overheat, which could cause it to fail.

## Disengagement

If fast declutching is required, e.g. in slippery conditions, move the gear lever to N, neutral.

### I-Shift, general

I-Shift is an automated manual gearbox with 12 forward gears and 4 reverse gears. The clutch and gear changing are operated fully automatically so that the driver can concentrate on driving in traffic. If required, the driver can choose to change gear manually. The gear shifter is mounted on the driver's seat.

I-Shift is delivered with different software packages. As some functions are optional, not everything in this document may be applicable to your gearbox.

### Program packages

The gearbox has different characteristics and functions depending on the program package that is installed. When the lever is tilted, (see “Tilting the gear shift lever”) the program package the gearbox is equipped with is shown in the display. For this, gearbox information must be selected as favourite in the display. The following program packages are available:

- **Basic** (B is shown in the display) is the standard program for the gearbox
- **Distribution & Construction** (DC is shown in the display) includes functions that make the truck easier to manoeuvre, e.g.:
  - brake program
  - several functions that work together with EBS
- **Long haul & Economy** (FE is shown in the display) includes functions that contribute to improved fuel consumption as well as functions that make the truck easier to manoeuvre. In addition to the same functions as the Distribution & Construction package there is also a freewheel function, I-roll, and Smart cruise.
- **Heavy Duty transports** (HD is shown in the display) is intended for heavy duty transportation. Driveability and comfort are optimised for heavy weights, but the mode can be deselected for lighter

loads to improve fuel consumption and give better comfort.

Basic is the standard program and the other programs include extra equipment. What options to choose from depends on which program package that has been chosen. See the table below.

Function	Program packages			
	Basic	Distribution & Construction	Long haul & Economy	Heavy Duty transports
Basic Power Take Off Functions	X	X	X	X
Basic Gear Selection Adjustment	X	X	X	X
Basic Vocational Functions	X	X	X	X
Basic Shift Strategy	X	X	X	X
Performance Shift	X	X	X	X
Gearbox Oil Temperature Monitor	X	X	X	X
Heavy Start Engagement	X	X	X	X
Enhanced Shift Strategy		X	X	X
Launch Control		X	X	X
I-Roll			X	X
Smart Cruise Control			X	X
Heavy Duty GCW Control				X

The table below shows additional optional functions that are available for each program package respectively.

Possible options	Program packages			
	Basic	Distribution & Construction	Long haul & Economy	Heavy Duty
Enhanced Power Take Off Functions	O	O	O	O

Possible options	Program packages			
	Basic	Distribution & Construction	Long haul & Economy	Heavy Duty
Enhanced Gear Selection Adjustment, incl. Kick-down		O	O	O
Enhanced Performance - Bad Roads		O	O	O

## Function description

### Standard characteristics

#### Basic Power Take-Off Functions

Facilitates power take-off operation.

Pre-defined split gear positions determine which split gear is to be engaged when one or two power take-offs are connected. As the choice of gear is adapted to the engine speed limitation, software parameters can be set. Then the selection of gear is adapted to any limitation of the engine speed due to bodywork functions.

#### Basic Gear Selection Adjustment

Provides the possibility to adjust gear selection with the gear shift lever's buttons while engine braking in automatic mode.

#### Basic Vocational Functions

Makes it possible to choose between driving programs "Economy" and "Power".

#### Basic Shift Strategy

Automatic choice of starting gear.

#### Performance Shift

Allows adjustment of automatically selected gear when engine braking.

**Gearbox Oil Temperature Monitor**

Shows the gearbox oil temperature in the information display.

**Heavy Start Engagement**

Starting with higher engine speed in power program in 1st, which gives a higher starting torque. The function increases the engine speed to facilitate heavy starts. This is useful e.g. when the truck is stuck in soft surfaces.

**Optional characteristics****Enhanced Shift Strategy**

Works together with the ECS and EBS to select the correct gear for smooth movement on surfaces difficult to manoeuvre or to get the maximum effect from the auxiliary brakes.

**Launch Control**

Allows the engine to drive the wheels at idle without the clutch slipping, which can be useful when e.g. driving in traffic queues.

**I-Roll (only together with VEB/VEB+)**

Automatic engagement and disengagement of the freewheel function, with the aim of reducing fuel consumption. When the accelerator pedal is released, the driveline is disconnected so that the vehicle can roll freely, and the engine is brought down to its idling speed.

**Smart Cruise Control**

Only active when the cruise control is activated. Saves fuel by deactivating the auxiliary brakes in certain programs. The function improves the cruise control function by releasing the auxiliary brakes at the end of downhill slopes.

## Heavy Duty GCW Control

Matches gear change strategies and clutch operations with high total weights (>85 tonnes).

## Enhanced Power Take Off Functions

Additional functions that support power take-off driving.

## Enhanced Gear Selection Adjustment in Auto incl. Kick-down

Enables selection of gears in automatic mode even when the accelerator pedal is depressed. There is also a Kickdown function for maximising the acceleration of the truck.

## Enhanced Performance – Bad Roads

Enhanced performance program for difficult conditions on i.e. poor roads in forests, construction sites or off-road driving.

## Gear shifter

The gear shifter is fixed to the seat and the gear shift lever can be tilted to allow the driver to move freely around the cab without being hindered by the lever.

## Gear shift lever

On the side of the gear shift lever facing the driver's seat is a +/- button (A) with spring-loaded up and down positions, and a neutral position in the middle. On the top is a button (B) that is used for tilting the gear shift lever to the horizontal position. On the front of the gear shift lever is also a lock (C) to prevent unintentional gear engagement. The lock must be pressed in for the following gear changes:

- from N to R
- from N to any of the forward driving programs

The lock does not need to be pressed when the gear shift lever is moved from A to M.



The gear shift lever can always be moved to N without having to press a button.

## Gear shift lever positions

The gear shift lever position can be changed between five different positions.

- R** Reverse. Changing up and down is done using the +/- button on the gear shift lever.
- N** Neutral. No gear engaged.
- A** Automatic mode. The gearbox will automatically select the correct gear with respect to load, incline, speed and throttle.
- M** Manual mode. Changing up and down is done using the +/- button on the gear shift lever.
- F** The gear shift lever is tilted.

## Tilting the gear shift lever

The gear shift lever can be tilted to horizontal position to allow easy movement between the driver's seat and other parts of the cab.

To tilt the gear shift lever:

- Make sure the gear shift lever is in neutral position N
- Press in the button on top of the gear shift lever and tilt the lever forwards, past the reverse position R, to the horizontal position

To raise the gear shift lever for driving:

- Move the gear shift lever up, past the reverse position R, until it locks in neutral N

When the gear shift lever is tilted, the driving program the truck is equipped with is shown in the display, see “Program packages”.



J4020429



## Buttons

### Changing up/down

The +/- button is used for:

- changing up or down, one or more gear change steps at a time in manual mode
- adjusting gears in automatic mode
- selecting split gear in neutral position when using a power take-off
- selecting reverse gear
- selection of starting gear in automatic mode



J4020430

### Economy/Power (E/P)

There is an economy/power button (E/P) on top of the gear shifter. This is used to:

- switch between the economy program and the power program. (Also in extended power program if it has been chosen.)
- activate/inactivate the Heavy Duty program by pressing in the button for at least three seconds.



J4020431

## Limp home (L)

L is used to activate limp home, see “Actions with gearbox malfunction”.



J4020432

## Display

Select the GAUGES menu from the display to view information on I-Shift (applies to both a stationary vehicle and one in motion). Information about the gearbox is shown in the driver display.

See “Driver Instruction Display” for information about how to set information about the gearbox as favourite display.

The gearbox section is divided into smaller sections showing:

- 1 Driving programs
- 2 Selected gear
- 3 Available gears (down/up)
- 4 Gear shift lever position

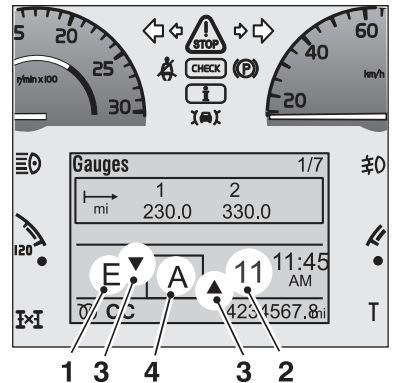

J3018210

### 1. Driving programs

The section to the left in the display shows the current driving program. The following driving programs are available (depending on which program package has been chosen):

E = Economy

E+ = I-Roll possible

P = Power

P+ = enhanced power program for difficult conditions  
on poor roads

B = Braking program

L = Limp home function

HD = Heavy Duty

For more information about driving programs, see  
section “Driving”.

## 2. Selected gear

The section to the right in the gearbox section shows  
the selected gear.

Gears 1–12

N = Neutral (N1 = low split, N2 = high split)

R = Reverse no. 1–4

## 3. Available gears

The section second from the left in the gearbox section  
shows with arrows the number of lower gears  
available (maximum 3 arrows). The section second  
from the right in the gearbox section shows how many  
higher gears are available in the same way (maximum  
3 arrows).

## 4. Gear shift lever position

The section in the middle shows the gear shift lever  
position.

R = Reverse

N = Neutral

A = Automatic

M = Manual

F = Fold, i.e. tilted gear shift lever

## Automatic gear change

The simplest way to drive the truck is to use the automatic program (position A). Gear changing is done automatically so that the driver can concentrate on the actual driving.

When changing gear, the system will control the clutch, gearbox and throttle. The system selects the gear and the point in time for gear change for optimum driving performance based on accelerator pedal position, truck weight, road inclination, vehicle acceleration, etc.

Automatic driving is recommended as often as possible to use the gearbox's potential to its maximum.

It is also possible to manually adjust the gears up or down in automatic mode. The arrows in the display show how many steps it is possible to change up or down.

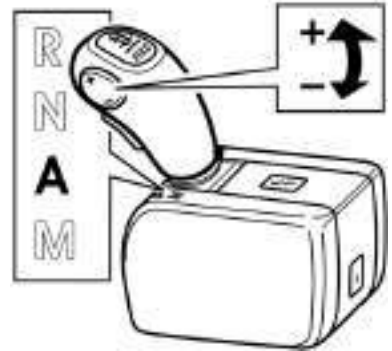

J4020433

## Automatic choice of starting gear

The gearbox selects the most suitable starting gear with respect to weight and the road's inclination.

## Adjusting the starting gear

You can also manually select a starting gear by using the + and – buttons.

Keep the minus button pressed and move the lever to the A or M position to quickly select starting gear 1. This can be advantageous e.g. when marshalling, when one changes between forward and reverse gears.

After a trailer has been disconnected (electrically) from the tractor, the lowest starting gear is used until the vehicle has moved a few metres to get smoother marshalling. When the air suspension is set to manual mode for height adjustment, e.g. when marshalling, starting gear 1 is automatically selected for a slower and smoother start.

### I-Roll

I-Roll (freewheel) can be activated if the stalk for the auxiliary brake, to the right of the steering wheel, is in the A position and E+ is shown in the display. When I-Roll is activated the split gear is put into neutral.

I-Roll is activated in different ways depending on the cruise control being active or not. When the I-Roll is activated, N is shown as the gear in the info display and the engine goes to idle.

#### **If the cruise control is active:**

- I-Roll is engaged on downhill slopes when the speed exceeds the set driving speed (for example 80 km/h). The set permitted excess speed must be 5 km/h or more. (See the “Driver's Manual”, section on auxiliary brakes for more information as to how the auxiliary brake functions and how the excess speed can be set.)
- I-Roll is disengaged when the speed exceeds the selected overspeed or below, or just below, the set driving speed (for example 80 km/h).
- The I-Roll function also includes the Smart Cruise Control that inactivates the auxiliary brakes at the end of downhill slopes to further save fuel.

#### **If the cruise control is not active:**

- I-Roll is engaged when the accelerator pedal is released and the road is flat or slopes gradually up- or downhill.
- The I-Roll is disengaged when the brake pedal is depressed, the accelerator pedal is depressed, the stalk for the auxiliary brake is set in position 0, 1, 2, 3 or B or if the gear shift lever is set to position M.

Inactivate I-Roll by pressing the minus button on the gear shift lever or by moving the auxiliary brake stalk to the 0 position.

## Locking gear

Example when automatic up or down-changing is not desired can be:

- When the truck approaches a crest of a hill and one wants to prevent an unnecessary down-change.
- On an uphill slope with a flat section.
- When driving on poor surfaces.

When automatic up or down-changing is not desired, move the lever from position A to M. Additional changing will not occur now and the engaged gear is retained. To go back to the automated program and thereby automatic gear changing again, move the gear shift lever back to A.

The function can be used in all forward gears (1 to 12).



J4020434

### Note!

There is risk of over-revving when the gear is locked.

### Note!

If the vehicle is stopped with a not permitted starting gear engaged in the M mode, the starting gear is automatically selected.

### Caution!

Starting in too high a gear strains the clutch a lot and can increase the risk for clutch breakdown.

## Driving programs

There are four different driving programs:

- economy
- power or enhanced power for difficult conditions on poor roads
- braking program
- HD (Heavy Duty)

### Economy

When the engine is started, the economy program is always selected (shown as an E in the display). The economy program is optimised for best fuel consumption and is used when driving in normal conditions.

### Power

The power program is engaged/disengaged using the E/P button (see illustration). When the program is engaged P/P+ is shown in the display. The power program prioritises driveability at the sacrifice of optimal fuel consumption and is used when driving in hilly terrain and off-road. The power program generally uses higher engine speeds than economy, and a lower starting gear is selected.

To save fuel, the gearbox will automatically switch off the power program when it is no longer required and returns to the economy program.

Trucks equipped with the enhanced power program P+ has additional functions suited for driving in hilly terrain and off-road. The program remains active until the economy program is selected. (The function is optional.)

### Braking program

A special braking program can be engaged (a B is shown in the display) using the stalk for the auxiliary brakes. See the “Driver's Manual”, section on auxiliary brakes. (The function is optional.)



J4020431

## HD (Heavy Duty)

The HD program should be used when driving with heavy loads. The HD program is activated/inactivated by holding the E/P button depressed for at least three seconds. When the program is engaged “HD” is shown in the display. The selection remains even if the ignition is switched off.

When the HD driving program is activated, starting gear 1 is selected automatically.

(The function is optional.)

## Kickdown

Kick-down is obtained by depressing the accelerator completely (position B). Kick-down optimises the choice of gear/throttle for maximum acceleration which most often leads to a down shift. Kick-down functions in both the economy and power programs, but not in the manual mode M or in driving program P +. Kick-down optimises the vehicle's power at the expense of optimum fuel consumption. For the lowest fuel consumption, only use the kick-down when necessary. The accelerator pedal always has a kick-down position, but access to the function is an option.

Position A = full throttle

Position B = kick-down

(Kick-down is an option.)

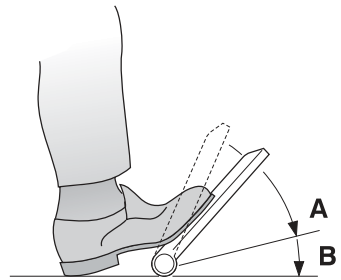

J2012347



## Manual gear changing

You can drive the truck entirely with manual gear changing or take over from the automatic gear changing system whenever required. Gear changing is done by first moving the lever to the manual position M. The +/- button on the side of the lever is then used to select the gear.

For a new gear, the +/- button must be pressed once for each gear step upwards or downwards, to the desired gear.

Press several times on the +/- button in sequence to shift through several gears at once.

Gear changing takes place as soon as the +/- button is released.

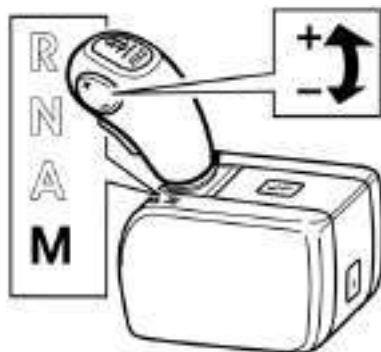

J4020435

### Note!

Do not release the accelerator pedal while changing gear.

### Note!

If the vehicle is stopped with a not permitted starting gear engaged in the M mode, the starting gear is automatically selected.



### Caution!

Starting in too high a gear strains the clutch a lot and can increase the risk for clutch breakdown.

## Reverse gears

The gearbox has four reverse gears (R1 to R4). The system will select R1 automatically when the gear shift lever is moved to R when the truck is stationary.

When driving, it is possible to shift between gears R1 and R2 and between R3 and R4. To change gear between R2 and R3 the truck must be stationary.

Manual gear shifting is done using the +/- button on the gear shift lever.

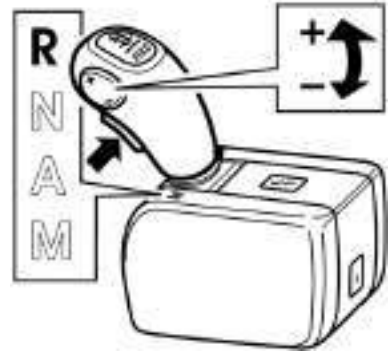

J4020436

### Note!

The gear shift lever lock must be pressed in before the gear shift lever can be moved from N to R.



### Caution!

Starting in too high a gear strains the clutch a lot and can increase the risk for clutch breakdown.

### Actions with gearbox malfunction

If the gearbox has a fault which means you cannot drive the truck, activate the Limp home function to be able to drive the shortest way home or to a workshop.

Activate Limp home as follows:

- 1 Move the gear shift lever to N
- 2 Keep L pressed in on the gear shifter cover and at the same time move the gear shift lever to A  
Limp home is activated
- 3 Move the gear shift lever to M
- 4 Select gear using the +/- button on the gear shift lever

When Limp home is selected, it is not possible to drive if the gear shift lever is in position A. Only gears 1, 3 and 5 forwards and 1 reverse can be used. Gear shifting is only possible when the truck is stationary.

The L button does not need to be pressed in again when you change between the M and R modes.

The Limp home function is disengaged when the ignition is turned off.



J4020432

#### **Note!**

The Limp home function should only be used for short distances.

### Fuel economy driving

I-Shift is optimised for the best fuel consumption in relation to the truck's situation. For the best fuel savings, choose to drive in A mode as much as possible. Only choose the M mode when the driving conditions require manual intervention.

### I-Roll

During normal driving, the gear shift lever should be in the A position and the auxiliary brake in the A position in order for I-Roll to be accessible. Use I-Roll as much as possible, e.g. on slight downhill slopes.

Set the cruise control's speed slightly lower and instead increase the overspeed. This gives more

opportunities when I-Roll can be activated and thereby save fuel.

### **Prevents down-changing**

In certain cases it can be better to remain in a higher gear even if the engine speed is low. For example, just before the top of a hill when you want to drive over the crest without changing down, which saves fuel. When driving, keep the plus button pressed in until the truck starts to accelerate again, to prevent down-changing.

### **Prevents up-changing**

To prevent an up-change when e.g. driving on an uphill slope, the minus button can be held in until the truck starts to retard.

The function can also be used just before an uphill slope to get a higher speed into the uphill slope. Down-changing functions normally in these cases.

### **Greatest possible down-change**

To obtain the greatest possible down-change e.g. just before a steep hill:

- Hold the minus button pressed in

AND

- Move the gear shift lever from the A to the M position
- Release the minus button

This gives a great down-change step when the minus button is released, for the purpose of immediately getting a high engine speed in the vehicle. Keep the lever in the M position as long as you wish to prevent a new gear change.

### **Save brakes**

Preferably use the engine brake to brake towards a stop to save the service brakes. When braking hard, brake program B can be used. Down-changing will

then occur which contributes to an increased braking effect from the engine brake.

### Queue driving

The Launch control function makes it possible to drive the truck at idle, which can be suitable when driving in traffic queues. If you have chosen

“Enhanced Gear Selection adjustment, incl Kick-down” then it is also possible to change up and down to adjust the speed to the traffic. The gearbox will then increase the engine speed a little to be able to change gear.

Activating while standing still:

- 1 Choose position A or M
- 2 Release the brake
- 3 Depress the accelerator pedal
- 4 Release the accelerator pedal once the vehicle starts to move forward.

When the brake pedal is depressed or it becomes so heavy that the engine risks stopping, the clutch is disengaged to prevent the engine from stopping. To return to queue driving, press on the accelerator pedal.

### Hill start

If the truck is equipped with Hill Start Aid, this should be used to prevent the truck from rolling backwards when starting on hills. (See “Driver instruction EBS”)

If there is no Hill Start Aid installed:

- Hold the vehicle stationary using the parking brake.
- Move the gear shift lever to the A or M position and select a suitable starting gear.
- Depress the accelerator pedal at the same time as releasing the parking brake.

#### Note!

The truck does not need to be stationary for the function to be activated.

#### Note!

At low speeds and gears, queue driving is activated automatically. Depress the brake pedal to inactivate.



#### Caution!

Never hold the vehicle stationary on an uphill slope by using the accelerator pedal. The clutch could overheat, which could cause it to fail.

## Driving on poor roads and in difficult conditions

In hilly or difficult driving conditions e.g. forest, construction site or off-road driving, it can be advantageous to use driving program P+ (option), which gives fewer gear changes. Gear selection is optimised for higher engine speeds to achieve good response and acceleration at the expense of optimum fuel consumption. This also gives greater tolerance for changes in road inclinations.

To prevent unplanned gear changing, select manual mode.

To prevent up-changing when e.g. driving uphill, the minus button can be held pressed in. The function can also be used just before an uphill slope to get a higher speed into the uphill slope.

To achieve the greatest down-change possible, e.g. just before a steep uphill slope, hold down the minus button, move the gear shift lever from position A to M and then release the minus button.

In normal driving conditions, return to the E driving program by pressing the E/P button for optimum fuel consumption.

## Disengaging

If rapid disengaging is required, e.g. in slippery conditions, move the gear shift lever to N, neutral.

## Starting when stuck

### 1. Rocking free

On slippery surfaces, e.g. snow or sand, the truck can be rocked free by carefully pressing down and releasing the accelerator pedal. You then gradually extend the wheel tracks you have got stuck in.

- 1 Make sure the differential locks (see “Driver’s Manual”) are fully engaged

- 2 Inactivate TCS (see “Driver's Manual”)
- 3 Choose driving program P/P+
- 4 Move the gear shift lever to the M position, gear 1, or the 1st reverse gear
- 5 Carefully press and release the accelerator pedal with a smooth pumping action

## 2. Heavy starts

When stuck with a heavy load on a hill or soft surface:

- 1 Choose driving program P/P+ or HD
- 2 Select starting gear 1
- 3 Completely depress the accelerator pedal
- 4 Keep the accelerator pedal depressed even if the warning for overloaded clutch appears

Extra torque from the engine is provided to help drive away.

The function should be used already at the first attempt to start, if it is an extra heavy start, as most torque is obtained with a cold clutch.

 <b>Warning!</b>
Starting in too high a gear strains the clutch a lot and can increase the risk for clutch breakdown.

## 3. Jerk starting

(Only for driving program P+)

If the truck has got stuck, it can be jerked loose by using extra engine torque obtained during a short time.

The engine is set to a somewhat higher engine speed and then the engine speed is reduced by using the clutch, which helps to give extra torque during a short time. The function can be used if the truck has e.g. got stuck in deep clay.

- 1 Choose driving program P+
- 2 Move the gear shift lever to the A or M position, gear 1, or to R
- 3 Keep the minus button pressed in
- 4 Completely depress the accelerator pedal (the engine speed will rise to 1300 rpm)
- 5 Release the minus button, the clutch is engaged

## Full VEB/VEB+ in manual mode

To increase comfort when driving in automatic mode, the engine brake performance is somewhat limited in low gears. When maximum engine braking is required e.g. in construction site driving, move the gear shift lever to the M position and change gear manually.

## Extra down-changing for maximum engine brake in low gears

For maximum comfort in low gears, the braking program B does not permit more than one down-change at a time when the gearbox has one of these gears engaged. To get maximum braking power e.g. at construction site driving, move the auxiliary brake stalk to the B position repeatedly, which results in a down-change each time. Thereby a higher engine speed and maximum engine brake is obtained.

## Changing driving direction

(Applies only to trucks equipped with EBS)

The driving direction, forwards (A or M) or backwards (R), can be changed while driving using the gear shifter without the brake pedal being used. The truck does not need to be standing still. The truck brakes slowly down automatically and when stationary the gear is changed for the new driving direction.

### **Note!**

The function must only be used when marshalling.

## Driving with the gearbox-mounted power take-off engaged

If the power take-off is engaged when the gear shift lever is in the N position, it is possible to move the truck by moving the gear shift lever to the A or M position. The power take-off will then stop temporarily when driving.

It is possible to engage the power take-off while driving at low speeds e.g. for gritting. To spare the gearbox, no gear changing should be done.



### Rocking to empty the platform

This method can be used to loosen loads that have got stuck on the truck's platform.

- 1 Move the gear shift lever to the M position
- 2 Select gear 1
- 3 Choose driving program P
- 4 Accelerate and brake hard
- 5 Repeat in the opposite direction, if required

### Driving on rollers

Sometimes the truck's drive shaft is used to drive e.g. wheel washing equipment before driving on public roads. Normally an up-change cannot take place while the front wheels are still. To be able to change up in these situations, do as follows:

- 1 Depress the accelerator pedal until the rear wheels start to rotate
- 2 After 10 seconds, it is possible to change up to the high range  
E<sup>^</sup> is shown in the display.

When driving on rollers it can be a problem to have time to change gear without the rear wheels losing speed. Therefore, you can start even in a gear higher than 6.

## General

The air suspension system must be active during all loading and unloading. The system is active if the ignition is turned on, the pressure in the air tanks is greater than 8 bar, when the parking brake is released, when the air suspension control box is used or if “Using air suspension with ignition turned off”.

On trucks in ADR it is sometimes necessary for the main power to be switched off during loading and unloading. Certain steps have to be taken, to avoid damage to the chassis. Refer to “Loading and unloading with main power disconnected”.



### Warning!

Turn off the electronic air suspension system when using support legs, a plough without floating position, or other equipment that affects the truck's height above the road. On trucks with equipment which affects ride height, there is a special switch to shut off the air suspension system. When body-building a truck at a later date, the function for turning off the air suspension system can be implemented by a Volvo workshop.

## Ride height control

### Change height with the control box

The height of the truck above ground can be controlled manually with the aid of the remote control box. This has a 3 meter long cable and magnets on the back so that it can be used and secured outside the cab.

The engine does not need to be running in order to use the control box, refer to “Using air suspension with ignition turned off”, but the air pressure in the system must be sufficient.

Road speed must be lower than 30 km/h when the control box is used.

# 256 Loading and unloading

1 Select manual control.

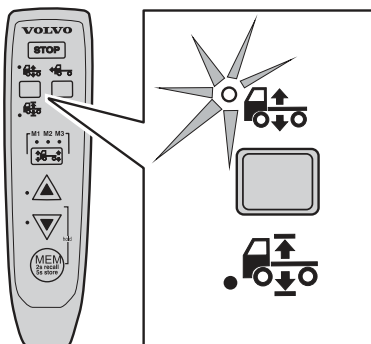

J7009823

2 Use the axle switch to select the axle to be adjusted:

- M1 for the front axle.
- M2, for both front and rear axle.
- M3 for rear axle.

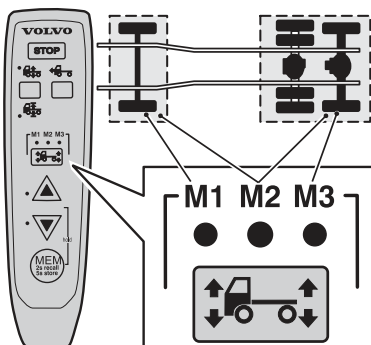

J7009818

3 Set the height you want with the height buttons.

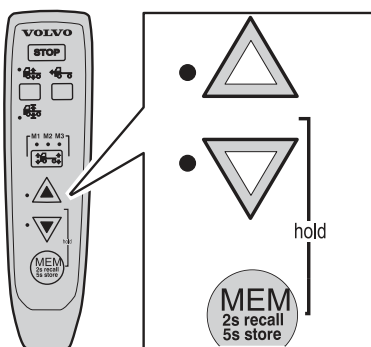

J7009819

To return the truck to driving height, select drive height. The previously set ride height is lost.

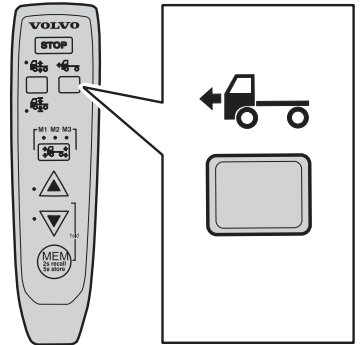

J7009822

1 Select manual control.

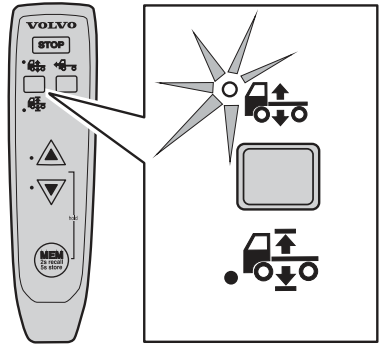

J7009835

2 Set the height you want with the height buttons.

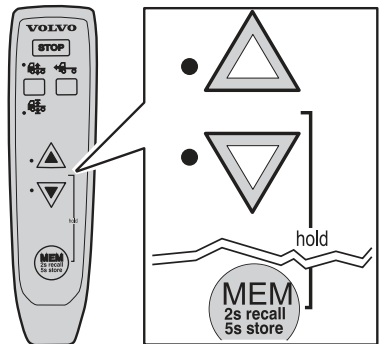

J7009831

## 258 Loading and unloading

To return the truck to driving height, select drive height. The previously set ride height is lost.

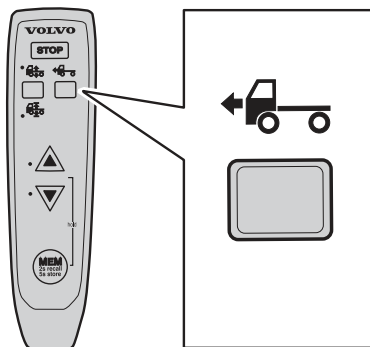

J7009834

## Loading and unloading height memory

### Storing a height in the memory

Three loading and unloading heights can be stored in the memory.

Road speed must be lower than 30 km/h when the control box is used.

1 Select manual control.

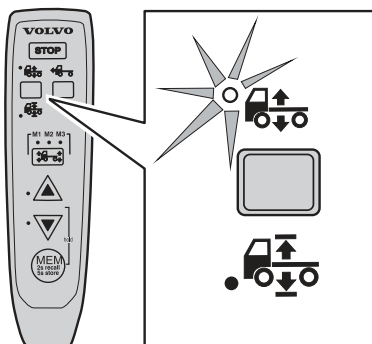

J7009823

2 Use the axle switch to select the axle to be adjusted:

- M1 for the front axle.
- M2, for both front and rear axle.
- M3 for rear axle.

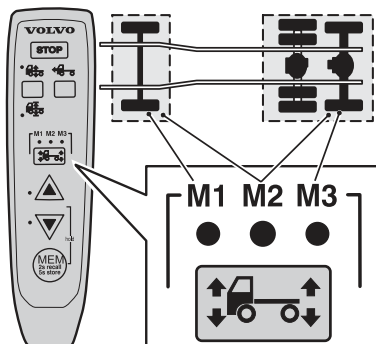

J7009818

3 Set the height you want with the height buttons.

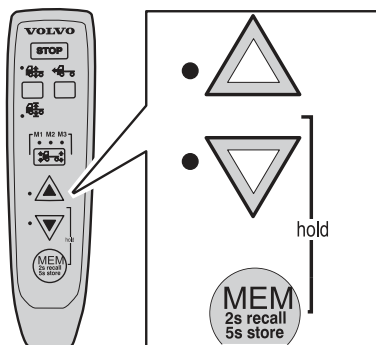

J7009819

4 Use the axle switch to choose the memory that the height will be stored in:

- M1, for memory 1.
- M2, for memory 2.
- M3, for memory 3.

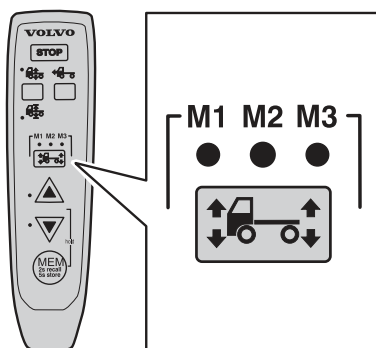

J7009825

## 260 Loading and unloading

5 Keep the memory button depressed for at least five seconds. The height is now stored in the selected memory.

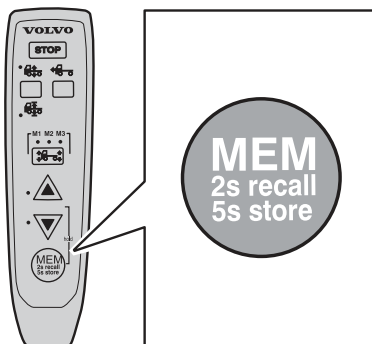

J7009820

To return the truck to driving height, select drive height.

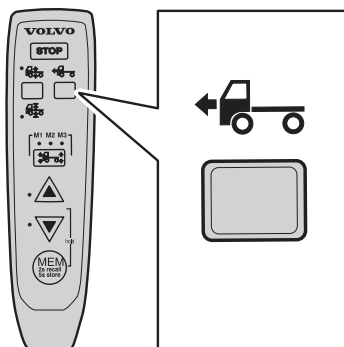

J7009822

One loading and unloading height can be stored in the memory.

1 Select manual control.

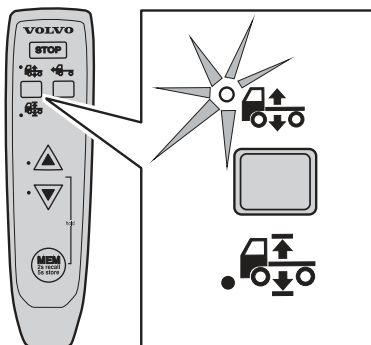

J7009835

2 Set the height you want with the height buttons.

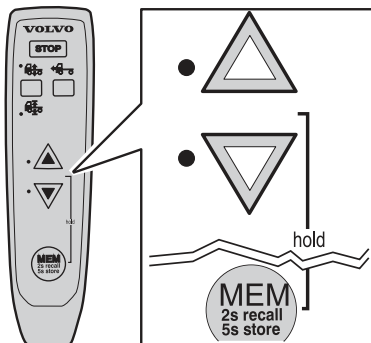

J7009831

3 Keep the memory button depressed for at least five seconds. The height is now stored in the selected memory.

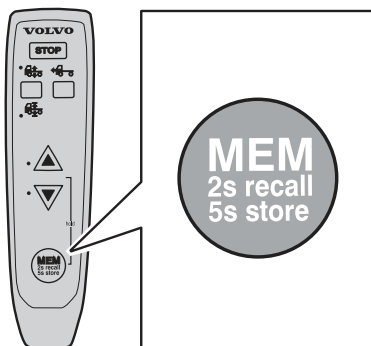

J7009832



## 262 Loading and unloading

To return the truck to driving height, select drive height.

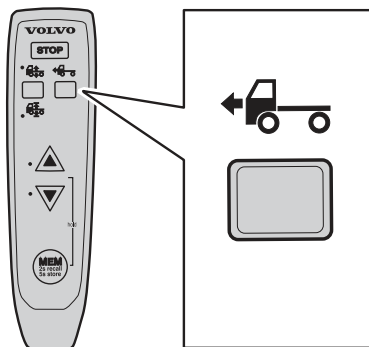

J7009834

### Retrieving a height from the memory

Road speed must be lower than 30 km/h when the control box is used.

1 Select manual control.

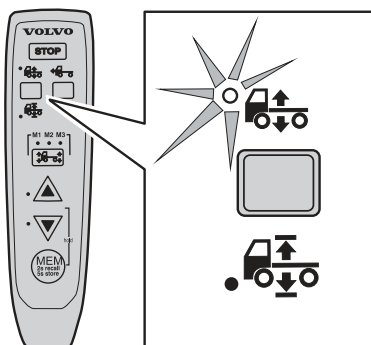

J7009823

2 Use the axle switch to select the memory where the height is stored:

- M1, for memory 1.
- M2, for memory 2.
- M3, for memory 3.

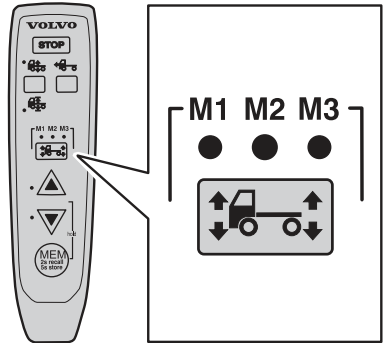

J7009825

3 Keep the memory button depressed for two seconds.

4 Release the button.

The truck assumes the stored height.

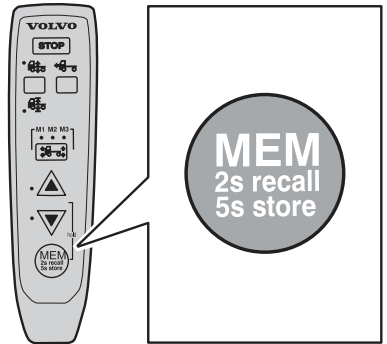

J7009820

To return the truck to driving height, select drive height.

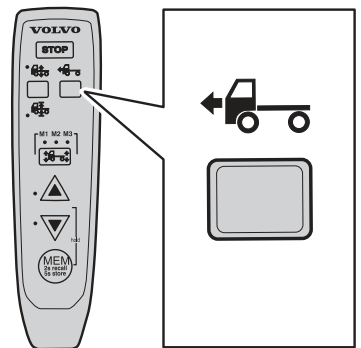

J7009822

## 264 Loading and unloading

Road speed must be lower than 30 km/h when the control box is used.

1 Select manual control.

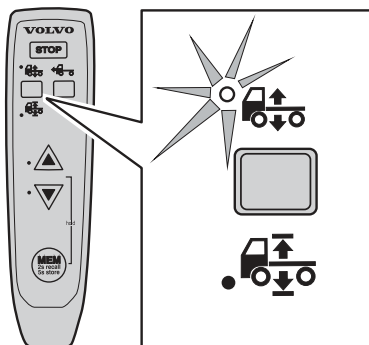

J7009835

2 Keep the memory button depressed for two seconds.

3 Release the button.

The truck assumes the stored height.

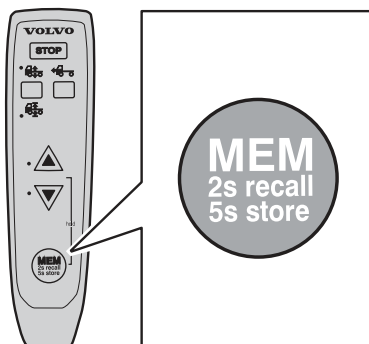

J7009832

To return the truck to driving height, select drive height.

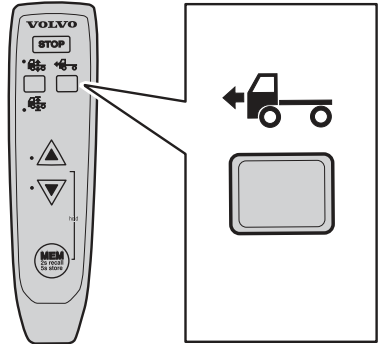

J7009834

## Quick unloading

For quick unloading, for example, when a container is lifted off, the vehicle must first be lowered to its lowest level with no air remaining in the bellows. The suspension could otherwise be damaged.

1 Select manual control.

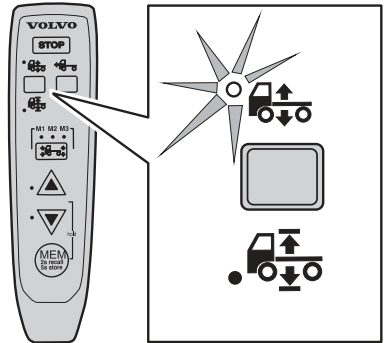

J7009823

# 266 Loading and unloading

2 Select M2, both axes.

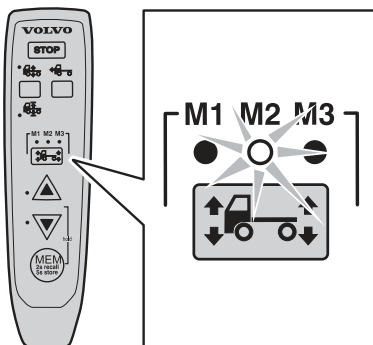

J7009824

3 Lower the rear suspension to its lowest position with the lower control button.

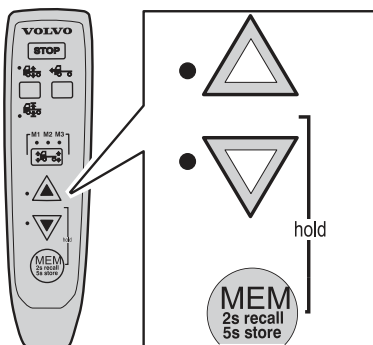

J7009819

1 Select manual control.

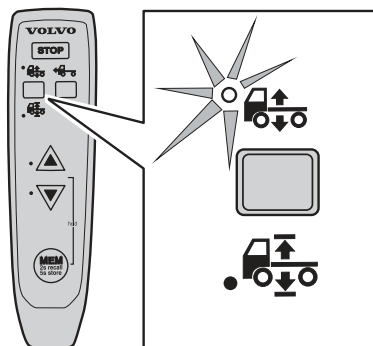

J7009835

2 Lower the rear suspension to its lowest position with the lower control button.

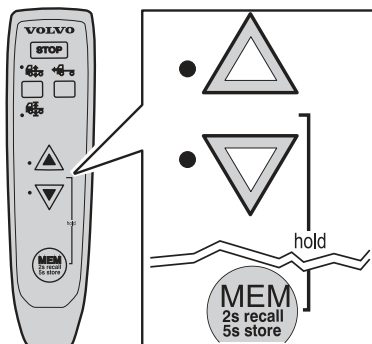

J7009831

## Using the air suspension with the ignition turned off

The ignition does not need to be on for the air suspension system to function. Although the key is in the stop position, you can regulate the height manually and allow the vehicle to regulate its height automatically. It is also possible to take out the key and lock the doors.

## Engaging the function

1 Turn the ignition key to the drive position.

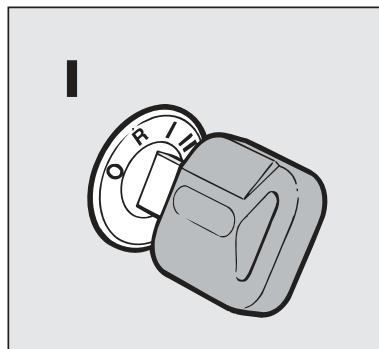

J7008414

# 268 Loading and unloading

2 Select manual control.

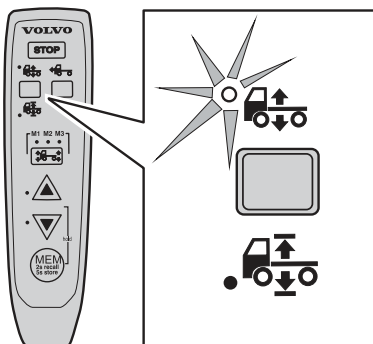

J7009823

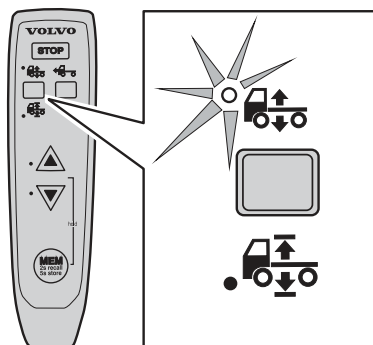

J7009835

3 Turn the ignition key to stop or radio position.

The air suspension can be controlled, manually or automatically, until the air pressure is insufficient. After four hours, the function is disconnected.

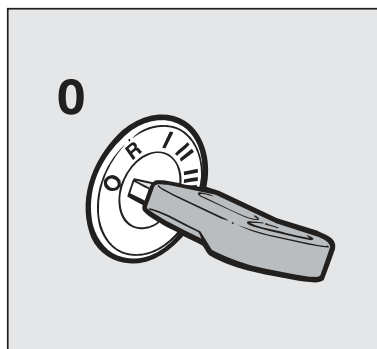

J7008413

## Disengaging the function

Turn the ignition key to the drive position.

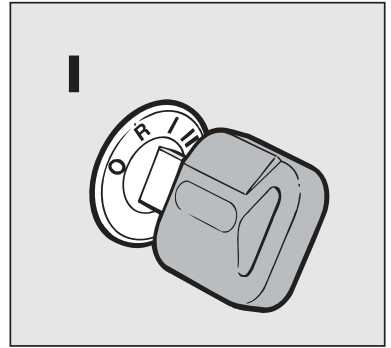

J7008414

or

Select ride height.

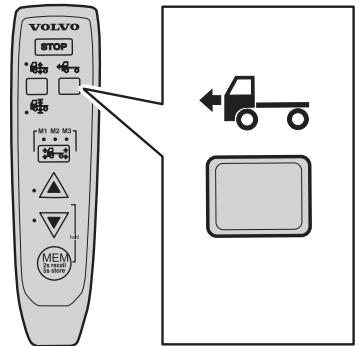

J7009822

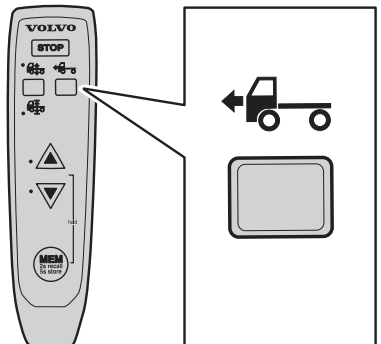

J7009834



## Loading and unloading with the main switch off

When loading and unloading vehicles in ADRtraffic, it is sometimes necessary for the main-power to be switched off. To prevent damage to the chassis, the truck must be raised to its highest level when loading and lowered to its lowest level when unloading.

### Before loading

Raise the truck to it's highest level

1 Select manual control.

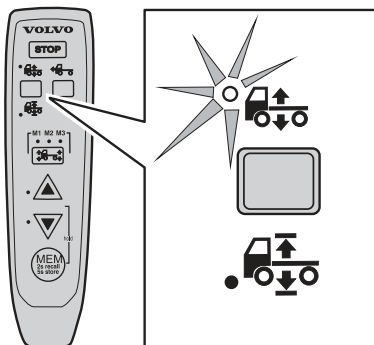

J7009823

2 Select M2, both axles.

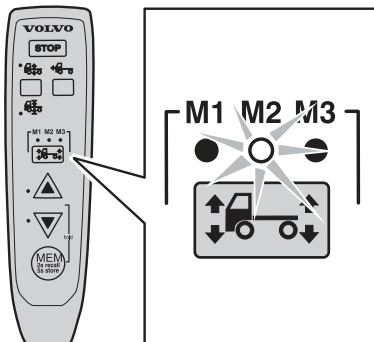

J7009824

3 Raise the rear suspension to its highest position with the upper control button.

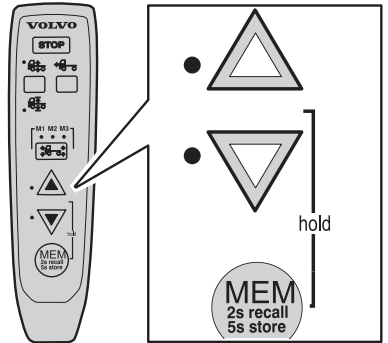

J7009819

4 Turn the ignition key to the stop position.

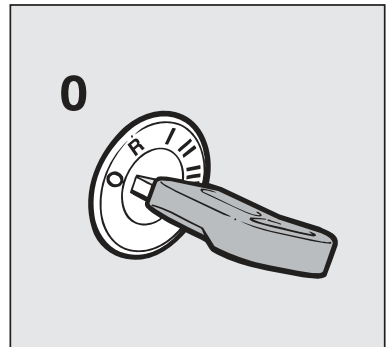

J7008413

5 Select ride height.

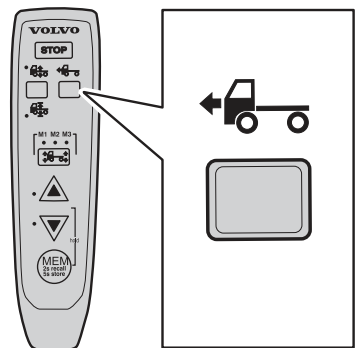

J7009822

6 Turn off the main switch.

# 272 Loading and unloading

1 Select manual control.

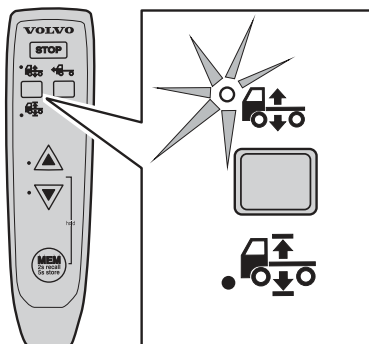

J7009835

2 Raise the rear suspension to its highest position with the upper control button.

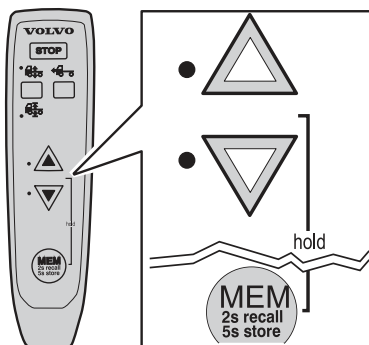

J7009831

3 Turn the ignition key to the stop position.

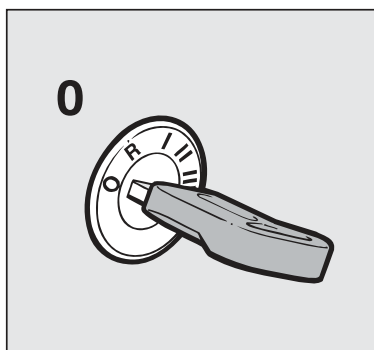

J7008413

4 Select ride height.

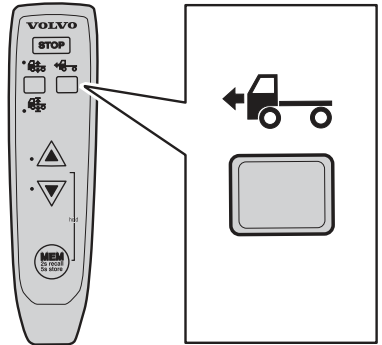

J7009834

5 Turn off the main switch.

## Before unloading

Lower the truck to it's lowest level:

1 Select manual control.

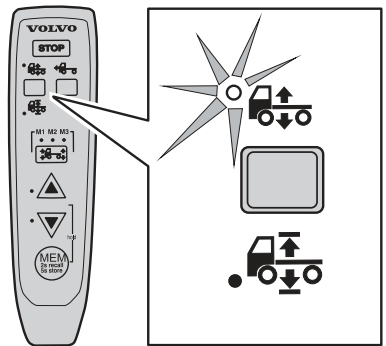

J7009823

## 274 Loading and unloading

2 Select M2, both axles.

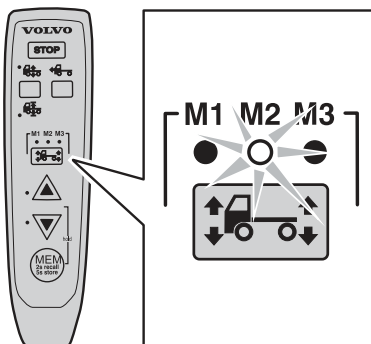

J7009824

3 Lower the rear suspension to its lowest position with the control button.

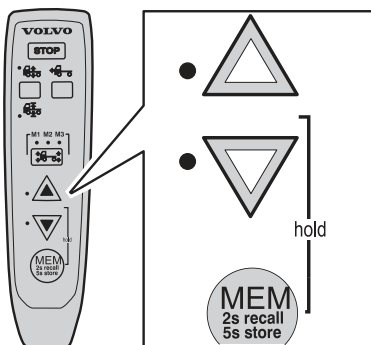

J7009819

4 Turn the ignition key to the stop position.

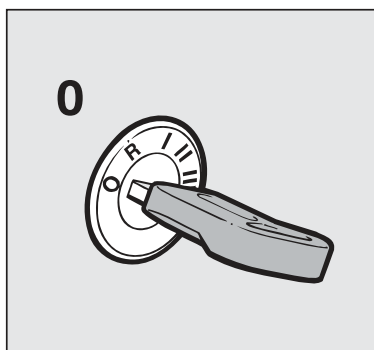

J7008413

5 Select ride height.

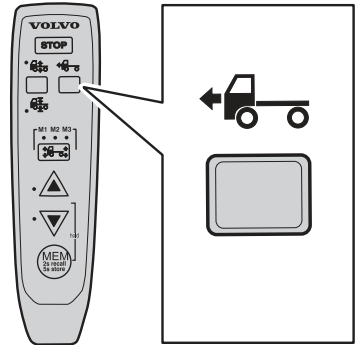

J7009822

6 Turn off the main switch.

1 Select manual control.

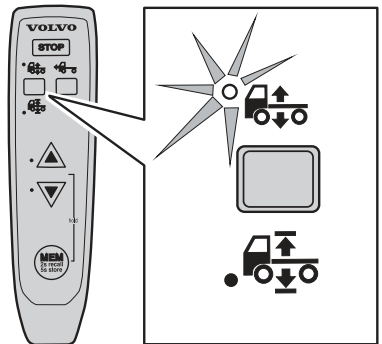

J7009835

2 Lower the rear suspension to its lowest position with the control button.

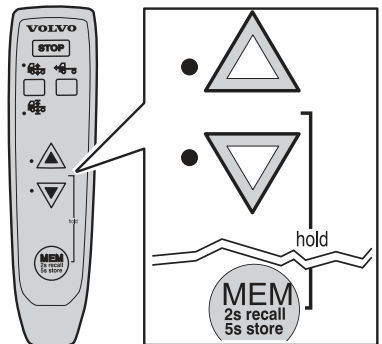

J7009831

## 276 Loading and unloading

---

3 Turn the ignition key to the stop position.

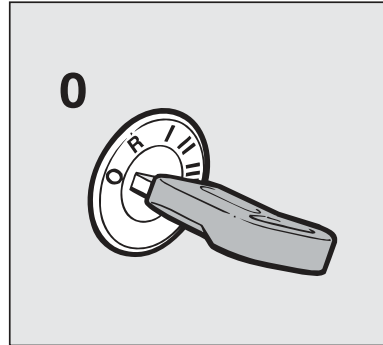

J7008413

4 Select ride height.

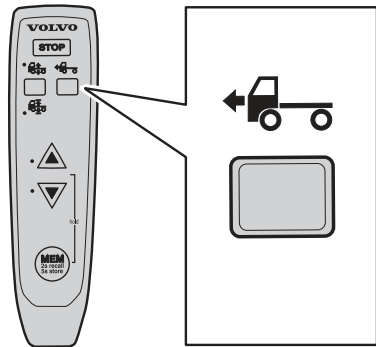

J7009834

5 Turn off the main switch.

### Fetch the swap body

- 1 Check that the load is secure
- 2 Check that the centre of gravity of the load is in conformity with the vehicle's capacity
- 3 Position the vehicle exactly in front of the platform's main members or guidance tunnel

**4** Position the guiding members correctly on the vehicle

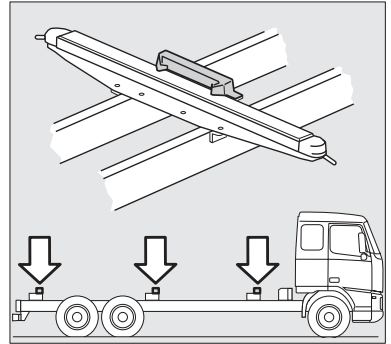

J0010205

**5** Check the length of the platform and if necessary place the stop members correctly on the vehicle

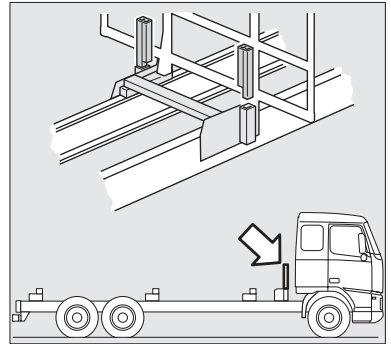

J0010206

**6** Open all four container locks on the vehicle

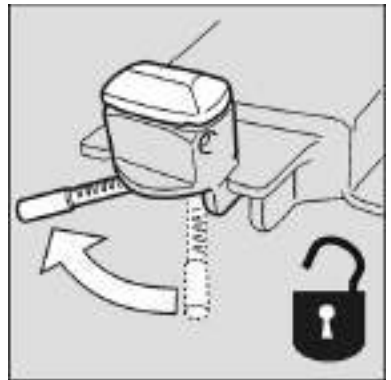

J9007931



## 278 Loading and unloading

7 Lower the lock pins with the switch in the cab

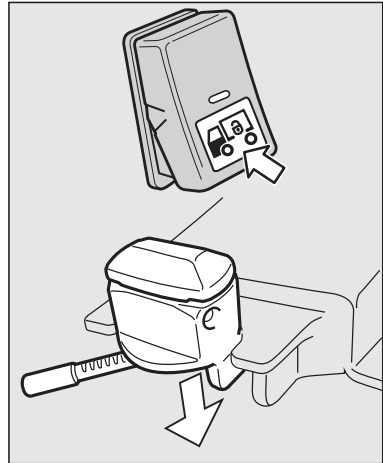

J9007932

8 Lower the truck on the air suspension so that it can be reversed with 50 mm clearance between the truck and the swap body

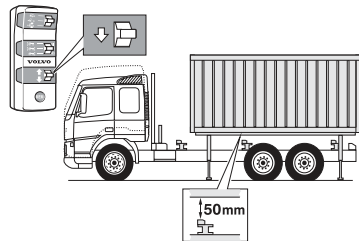

J9007934

9 Carefully reverse the vehicle in under the platform

10 Stop when the container locks on the vehicle are under the lock holes in the platform

11 Raise the vehicle with the air suspension until the support legs have been lifted sufficiently off the ground to be manoeuvrable. If shunting with hanging support legs the support legs must be lifted 100 mm from the ground

### **Note!**

Shunting with hanging support legs must be done at low speed and with maximum care.

12 Raise the lock pins with the switch in the cab

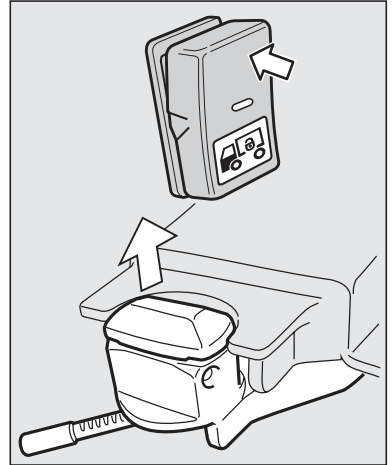

J9007995

13 Lock the container locks by turning them 90°

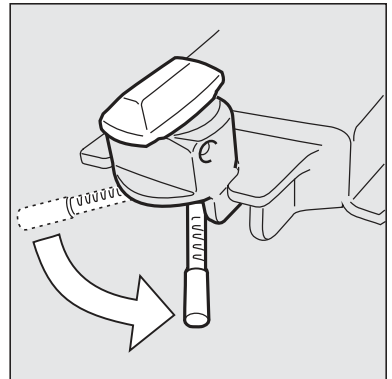

J9007933

14 Put the support legs in the transport position

## 280 Loading and unloading

15 Lower the lock pins with the switch in the cab in order to lock the platform on the vehicle

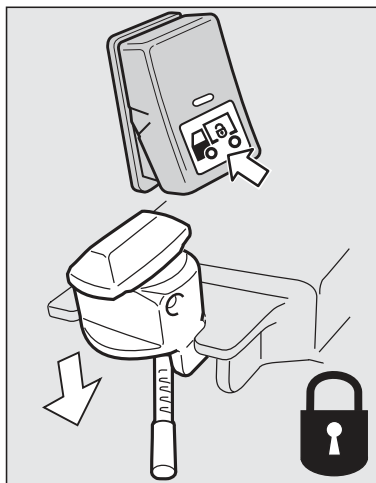

J9007994

16 Put the air suspension in the driving position

17 The vehicle is ready to be driven away

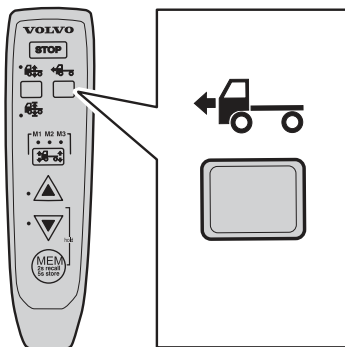

J7009822

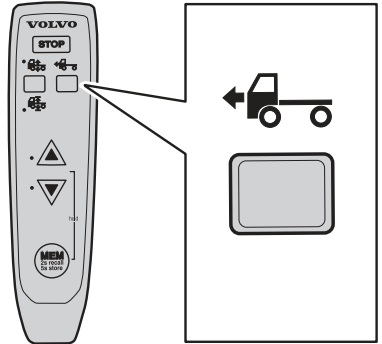

J7009834

## Leave the swap body

- 1 Check that the place where the platform is to be put is flat and will take the weight of the platform
- 2 Position the vehicle in the correct place for setting down
- 3 Raise the vehicle with the air suspension
- 4 Raise the lock pins with the switch in the cab

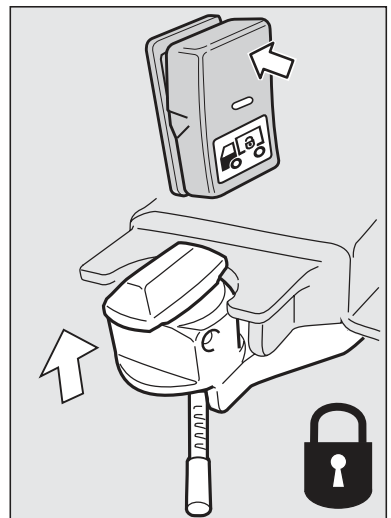

J9007997

## 282 Loading and unloading

---

5 Position the platform's support legs in the setting down position

6 Lock the support legs in the setting down position

7 Unlock the container locks

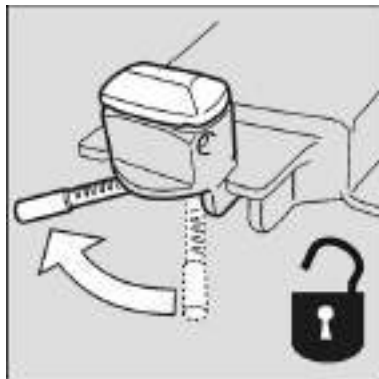

J9007931

8 Lower the truck on the air suspension so that there is 50 mm clearance between the truck and the swap body

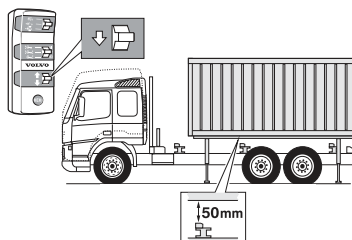

J9007934

**9** Lower the lock pins with the switch in the cab

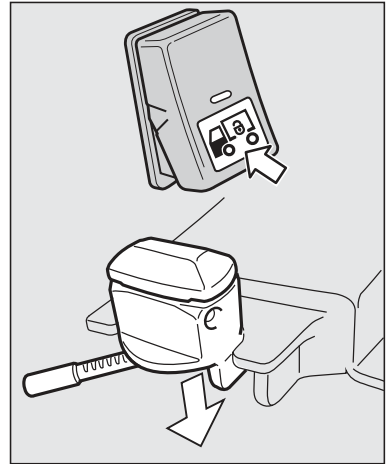

J9007932

**10** Carefully drive straight forward out from under the platform until the vehicle is completely outside the platform

**11** Put the air suspension in the driving position

**12** The vehicle is ready to be driven away

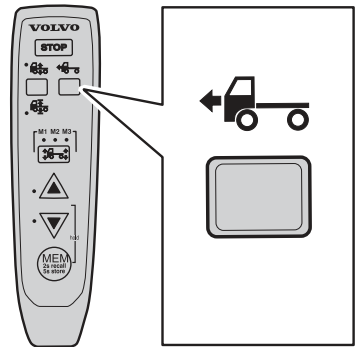

J7009822

## 284 Loading and unloading

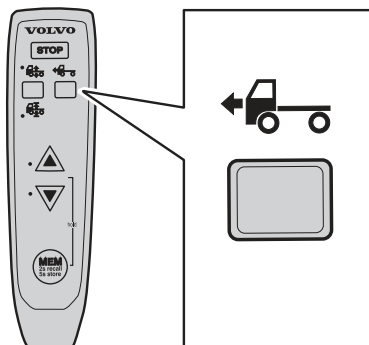

J7009834

### Fetch a container

1 Position the guiding members for the swap body in the holders so that a container can be positioned on the vehicle

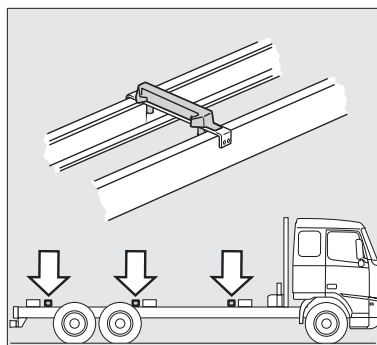

J0010207

2 Raise the lock pins with the switch in the cab

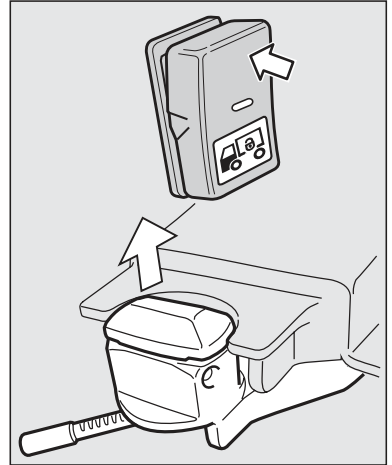

J9007995

3 Check that all four container locks are open

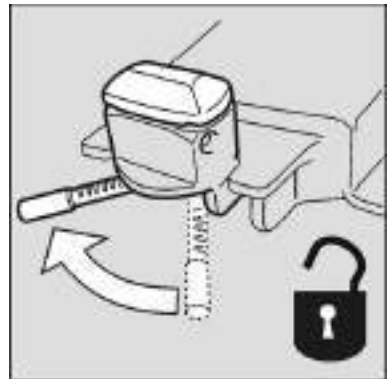

J9007931

4 Raise the air suspension to its highest level so that the chassis will not be damaged when the container is lifted on

5 The container is lifted on



## 286 Loading and unloading

---

6 Lock the container locks

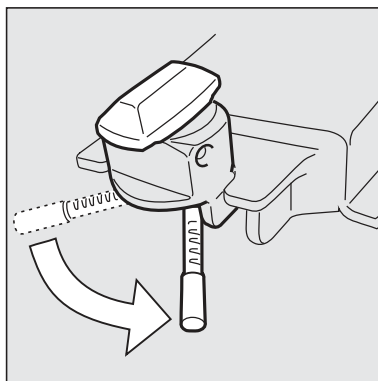

J9007933

7 Lower the lock pins with the switch in the cab

8 The vehicle is ready to be driven away

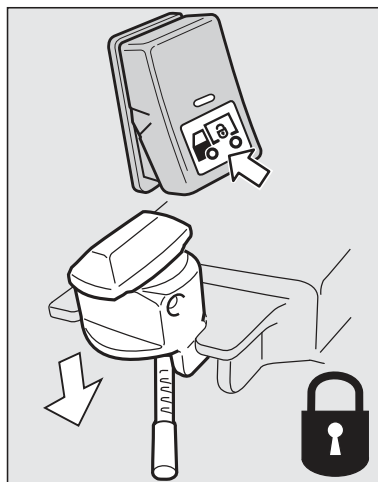

J9007994

### Deliver a container

1 Lower the air suspension to its lowest level so that the chassis is not damaged when the container is lifted off

2 Raise the lock pins with the switch in the cab

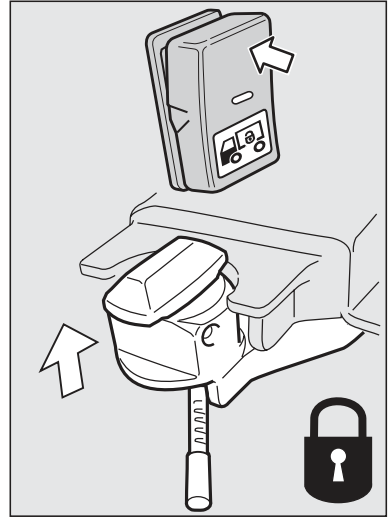

J9007997

3 Unlock the container locks

4 The container is lifted off

5 The vehicle is ready to be driven away

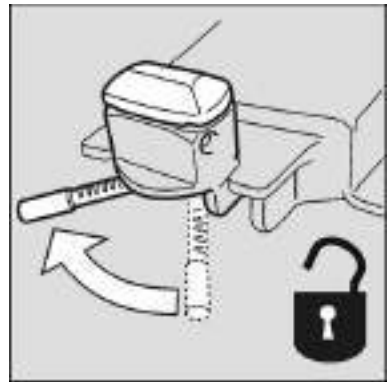

J9007931

## Load indicator

The load indicator can be found under "Vehicle data" on the display. The menu can only be accessed when the vehicle is stationary.

For general information on how the display functions, see "Driver instructions Display".

### Note!

The truck should be in a level position when gauging.

## 288 Loading and unloading

---





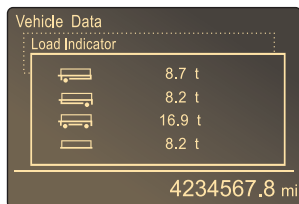
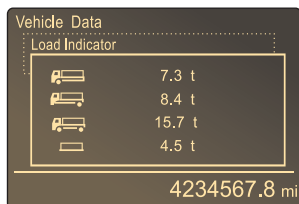







The display shows indicated pressure on each axle, indicated weight of the truck, indicated weight of the trailer and indicated weight of the load. With bogie and double drive axles the indicated weight on both axles is shown.

The values are updated every two seconds.



J3016133

The load indicator supports four types of equipage. The symbols in the display mean different things for different types, see table. When there is no value to be shown, " - - - " is shown instead.

	 Only truck	 Truck with multi-axled trailer	 Truck with single axled trailer	 Tractor with trailer
	Front axle load, truck	Front axle load, truck	Front axle load, truck	Front axle load, truck
	Rear axle load, truck	Rear axle load, truck	Rear axle load, truck	Rear axle load, truck
	Total weight, truck	Total weight, truck	Total weight, truck	Total weight, whole combination
	Load weight, truck	Load weight, truck	Load weight, truck	- - -
	- - -	Front axle load, trailer	Front axle load, trailer	- - -
	- - -	Rear axle load, trailer	- - -	Rear axle load, trailer
	- - -	Total weight, trailer	Total weight, trailer	- - -
	- - -	Load weight, trailer	Load weight, trailer	Load weight

If trailer, superstructure, turntable or suspension are altered, the load indicator must be recalibrated at a Volvo workshop, otherwise incorrect weights will be displayed.

In order to retain the reliability of the system, displayed values should be checked regularly. If necessary, a new calibration should be carried out.

If there is not normal working pressure in the air bellows, e.g. if the vehicle has been stationary for a while, then the correct value cannot be shown. " - - - "

## 290 Loading and unloading

---

is displayed until the normal working pressure of the air bellows is restored.

If a sensor is faulty ”- -” is shown for that axle. No value will then be shown for total weight and load.

## General

Volvo Trucks use SCR technology

(Selective Catalytic Reduction) catalytic exhaust gas cleaning — to meet the requirements of Euro 4, the new standard for exhaust gas emissions that came into force on 1 October 2006. A new EU legal requirement is introducing 1st October 2007 in order to monitor the fulfillment of exhaust emissions for Euro 4 and Euro 5 engines. In addition to the existing

OBD-system (On-Board Diagnostic) the law requires that there must also be a special level and diagnostic system for the engine's exhaust gas after-treatment system, which is known as NOx control monitoring (NOx = nitrous oxides).

NOx control monitoring system is to monitor:

- The level of NOx in the exhaust.
- The level of AdBlue in the tank.
- Faults in the emission control monitoring system.

The following effects will occur if faults are detected in the exhaust gas after-treatment system:

- The monitoring system will inform the driver via warning lamps and fault messages.
- "Non-erasable fault codes" are set.
- Possible derating of the engine (depending on type of fault).

## Conditions

The NOx control monitoring system is only active under the following conditions:

- Ambient temperature —7 C to +35 C.
- Altitude above sea level less than 1600 m.
- Coolant temperature above 70 C.

In order for a "non-erasable fault code" to be set (activated), a number of different basic conditions

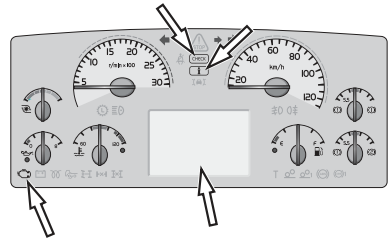

J2024483

## Note!

These conditions do not apply if the AdBlue tank is empty.

must be fulfilled. The conditions vary depending upon which fault has arisen. There are three different faults that generate a "non-erasable fault code":

- 1 Empty AdBlue tank.
- 2 NOx level exceeding the certified level.
- 3 The NOx level cannot be monitored.

### **Non-erasable fault codes**

With the new fault codes for NOx once the fault code has been set (becomes active), the fault code will be stored for 400 days and will not be erased, even if the current fault is remedied and the fault code becomes inactive.

Once a "non-erasable fault code" is generated, an estimation is made of the amount of time the engine was running whilst the current fault was active. In this way, you can obtain information about how long the engine was running with a fault in the emission system.

### **Derating (power reduction)**

A new feature for NOx control monitoring process means that when certain limits occur or a certain fault arises in the exhaust gas after-treatment system, a power reduction of 40% will occur. Before derating occurs, the control and warning lights will light and the instrument display will inform that derating will occur. Derating will be activated once the vehicle has stopped for the first time (with the engine running) after the occurrence of the fault, for example at the next red light. As soon as the reason for the power reduction has ceased, the power reduction will be deactivated the next time the engine goes to idle. Power reduction occurs during any of the following events:

- NOx level exceeding the certified level.
- AdBlue tank empty.
- The system could not monitor the NOx level during 50 hours of engine operation.

## Exhaust cleaning

The engines are fitted with an exhaust gas cleaning system which cleans the exhaust using the urea solution AdBlue. AdBlue is injected into the exhaust system at a point between the turbo and the silencer, which has an inbuilt SCR catalytic converter. The catalytic converter is used to reduce emissions of nitrogen oxides and particulates.

But in order to comply with the legal requirements of Euro 4, the exhaust gas needs further treatment, AdBlue is added.

## Fuel

For the catalytic converter to work optimally, sulphur-free (max 10 ppm sulphur) fuel should be used, in accordance with European standard EN590. As a temporary measure, fuel with up to 350 ppm sulphur content is permitted.

## AdBlue (Urea solution)

The urea solution is sold under the trademark AdBlue. It is a colourless liquid consisting of a mixture of urea and distilled water. It may have a slight smell of ammonia. The urea concentration of AdBlue is 32.5%. AdBlue fulfills the ISO standard 22241-1 (previously DIN-70070) and is the only Volvo approved urea solution for filling in Volvo trucks with Euro 4 engines. AdBlue may also be sold and marketed under other names depending on the distributor and may be used as long as the ISO standard 22241-1 is fulfilled.

AdBlue is not hazardous but it should be handled with care. If AdBlue is accidentally spilled on the truck, rinse the area with water and dry off with paper or a rag. The solution can be aggressive when hot and can therefore damage, for example, nearby electrical connectors, electrical wiring and hoses if spilled.

AdBlue freezes at approx.  $-11\text{ }^{\circ}\text{C}$ , but this is not a problem, as the SCR system is heated. The truck can be started and driven normally.



### Caution!

AdBlue that has been modified or replaced with another liquid that does not comply with ISO 22241-1, will lose its intended cleaning effect and can damage the SCR system.



### Caution!

AdBlue is very corrosive and can damage electrical connectors. If AdBlue gets into electrical connectors or wiring, they must be replaced. Cleaning electrical items is not enough.



## Driving a truck with a Euro 4 or Euro 5 engine

### Trucks with ADR

Bear in mind that the switch ADR is only for use in emergencies. When the engine is switched off, a process begins to pump clean the AdBlue nozzle and AdBlue supply lines. The process takes about 90 seconds and during this time the ADR switch must be switched on. It is especially important to do this in cold weather as there is a risk of the solution freezing. The process is not carried out if the ADR switch is used before or during the process.

### OBD

The truck is equipped with OBD (On-Board Diagnostics). MIL-symbol (MIL = Malfunction Indicator Lamp), located bottom left on the instrument panel will come on if there is an emission-related fault. The reason for the lamp being lit can be investigated during the next stop. If the lamp lights, the truck should be driven to an authorised Volvo workshop for checking. There is a delay in the system that can cause the MIL symbol to not light directly when the fault occurs but first somewhat later. According to legal regulations, the lamp must remain alight for a period after the fault has been corrected.



J3018128

### Display message — with falling AdBlue level

To check for the amount of AdBlue in the tank, step to the "Fuel Data" menu on the display and select "AdBlue". It is an advantage to have this selected as a favourite menu, see "Driver instructions, Display".

When there is only a small amount of AdBlue left in the tank (approx 10%), the information lamp will light and a message will be displayed to inform the driver that it is time to top up with AdBlue.

If the AdBlue tank is empty, the following message is shown on the display together with the information

### Note!

It may be a punishable offence not to use AdBlue or to try to interfere with the exhaust cleaning system.

Engine derate at next stop High emissions!
--

lamp and MIL symbol. Fill the tank immediately with AdBlue. When the empty tank message is shown, a certain amount of AdBlue is still circulating in the system. The injection stops of AdBlue.

The fact that the urea tank becomes empty during driving does not cause damage to the urea system or the engine, as the remaining solution in the system circulates and cools it. However, engine exhaust emissions increase when the dosing valve is closed and the exhaust gases are not further processed. If this is not rectified by filling with AdBlue engine power reduction will occur and a "non-erasable fault code" will be set for 400 days.

If the SCRsystem cannot circulate AdBlue the following message is shown together with the yellow information lamp (CHECK) and MIL symbol.

The next time the truck is stationary with the engine running, i.e. at traffic lights, the power will be reduced by 40% of max power. The following message is shown on the display together with the yellow warning lamp (CHECK) and MIL symbol. The truck's engine output returns to normal as soon as the AdBlue tank is filled.

### Display message - with malfunction of emission control monitoring system

If a fault occurs in the NOx monitoring system, the following message is shown on the display together with the yellow information lamp (CHECK) and MIL symbol.

If the system senses that the fault remains, the power will be reduced by 40% of max power. The following message is shown on the display together with the yellow information lamp (CHECK) and MILsymbol. The truck's engine power returns to normal when the system senses that the fault is rectified.

<p>Engine derate High emissions!</p>
--

<p>Engine derate at next stop High emissions!</p>
---

<p>Engine derate High emissions!</p>
--

### **Display message - with malfunction of dosing system for emission control**

If a fault occurs in the NOx dosing system, the following message is shown on the display together with the yellow information lamp (CHECK).

AdBlue system error

Visit workshop

### **Idling**

To safeguard the power supply, trucks with Euro 4 engines have a faster idling speed in cold weather. The engine electronic control system determines when the increased idling speed needs to be applied; it cannot be activated manually by the driver. If the truck is equipped with I-shift it is especially important, when idling, to engage neutral while the truck is stationary with the engine running. This is to prevent overloading the clutch and gearbox.

### **Exhaust**

The catalytic converter gets very hot and cools down more slowly than a normal silencer. This means that the gases in the end pipe, e.g when the engine is idling after driving, hold high temperatures for longer. The exhaust will have an odour that is different from engines without emission control. The difference is most noticeable when the engine is cold. A cloud of water vapour can be emitted during cold starting and when pulling away. This is more noticeable than for engines without exhaust gas cleaning. Vapour clouds can form with temperatures up to +5°C. Steam can also form during engine restart after a short break and when the engine brake is being used, but to a lesser extent than when starting from cold.

## Filling with AdBlue

AdBlue is not classed as being hazardous to the environment but should still be handled with care.

The AdBlue tank is mounted either on the right-hand side or left-hand side of the truck. The size of the tank varies proportionally with the size of the fuel tank.

Filling the AdBlue tank is via local distribution tank depots or fuel stations with a wide range of products. For further information on AdBlue availability, visit <http://www.findAdBlue.com>. Check the level in the tank each time the truck is refueled. This is done to ensure the amount of AdBlue is sufficient for the planned driving distance. Do not fill the AdBlue tank with fuel; this will damage the SCR system.

To prevent other liquids than AdBlue being poured into the AdBlue by mistake, the tank mouth and tank hole are designed so that they will not accept any other filling equipment. To further prevent any mistake in this area, the tank cap is painted blue and is marked with AdBlue. There is also a label on the tank warning against filling with anything but AdBlue.

Take care not to fill the fuel tank with AdBlue when standard filling equipment is not being used. This will contaminate the fuel and cause AdBlue to enter the injection system and combustion chambers, which can damage the engine.

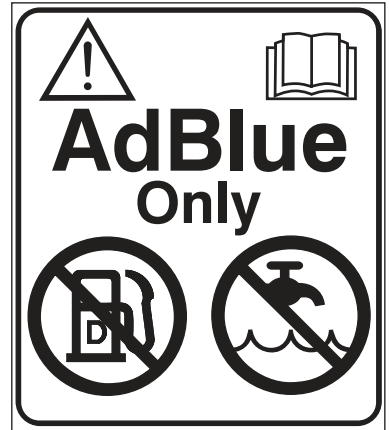

J2023221

### Note!

Filling with anything other than AdBlue can cause problems with the SCR system and light up the OBD symbol on the instrument panel.

### Caution!

Never put AdBlue into the fuel tank. This can damage the engine and the fuel system.

## Measures after spillage

With contact with the skin – rinse with plenty of water and remove contaminated clothing.

With contact with the eyes, rinse thoroughly with water for several minutes Call for medical help if necessary.

If inhaled – breathe fresh air and call for medical help if necessary.

Do not allow AdBlue to come into contact with other chemicals.

AdBlue is not flammable. If AdBlue is exposed to high temperatures, it will be reduced to ammonia and carbon dioxide.

If AdBlue is spilled on the truck, wipe off the excess and rinse with water. AdBlue is corrosive with metals such as copper and aluminium. It can also cause damage to alloys such as brass.

Spilled solution can form white crystals of concentrated AdBlue on the truck. Rinse the crystals away with water.

If spilt on a connector, the connector must be replaced, AdBlue is highly corrosive and will therefore damage the connector.



J9008510

## Note!

Urea spill must not be allowed to enter the normal drainage system.

 <b>Caution!</b>
Urea spilt on hot components can quickly generate vapour. Turn your face away!

## Cleaning the AdBlue tank

It can be necessary to clean out the AdBlue tank if it is inadvertently filled with diesel or some liquid other than AdBlue. Rinse out with water, and if this is not sufficient, use a domestic cleaning liquid. Rinse out thoroughly with water to ensure that there is no cleaning liquid residue left as this can damage the catalytic converter.

- 1 Place a collection vessel under the AdBlue tank bottom plug
- 2 Loosen and unscrew the plug a few turns until the contents start to run from the tank drain hole.
- 3 Allow it to drain until the tank is empty
- 4 Flush the tank out with clean water. Make sure the tank is properly drained before continuing
- 5 Replace the plug
- 6 Empty the container in a place where it will not constitute a risk to the environment

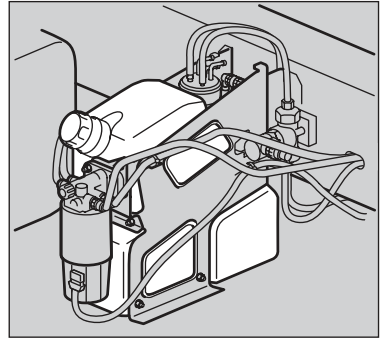

J2022819

### Note!

After emptying the tank, it must be filled with a minimum of 5 litres of new AdBlue.

## Diesel particulate filter

This vehicle is equipped with a ceramic particulate filter **that requires the use of low-sulphur fuel** (less than 50 ppm = 0.005 % sulphur) The lower the sulphur content of the fuel, the better the function and life of the system. I.e. if a fuel with 10 ppm sulphur is available, it is recommended to use such a fuel in the first hand. Use of fuel with a higher sulphur content or mixing in other fuel can destroy the particulate filter in a short time.

The particulate filter collects soot and ash particles. A large quantity of particles will cause a higher exhaust back-pressure, which leads to higher fuel consumption and unnecessary wear on the engine. To avoid this, there is a system that removes the soot particles automatically by combustion. The combustion process

### Note!

The fact that the vehicle is fitted with a particulate filter does not mean that it can be used in a different way than a vehicle without a particulate filter. Breathing the exhaust gases is still unhealthy, in other words good ventilation is still necessary when the vehicle is idling. A point-extraction exhaust hose shall be connected to the tail pipe if the engine must be run indoors.

is called active regeneration and consists of heating the filter so that the particles are burnt.

The particulate filter also removes inorganic contaminants (ash) which comes from engine oil additives. Ash cannot be burnt, so regular service of the particulate filter is necessary. To obtain the maximum service interval and best function, it is recommended that **engine oils with low ash content, VDS-4 or VDS-3 LSA are used**. The above named system informs the driver when a predetermined level of ash particles have accumulated in the particulate filter.

The particulate filter greatly reduces the emission of soot particulates (PM), hydrocarbons (HC) and carbon monoxide (CO). A proportion of the nitrogen oxides ( $\text{NO}_x$ ) in the exhaust gases from the engine are converted in the catalytic converter to nitrogen dioxide ( $\text{NO}_2$ ), which helps to burn the soot particulates which are caught by the filter. The total content of  $\text{NO}_x$  from the engine is not altered, but the proportion of  $\text{NO}_2$  is increased. The  $\text{NO}_2$  can, in moderate concentrations, irritate the respiratory passages and aggravate asthma. However, the particulate filter does contribute to a considerably improved environment on account of its capacity to considerably reduce the quantity of soot particulates, hydrocarbons and carbon monoxide.

### High content of soot particles in the particulate filter

#### Automatic regeneration of the particulate filter

There are two types of regeneration: automatic and manual. Automatic regeneration (see below) is performed while driving, manual regeneration when the vehicle is stationary.

When regeneration of the filter is necessary, a symbol is shown to the right and the message "Request regeneration" in the display. See also section "ATS" in the Driver's handbook.



Regeneration takes about 15–20 minutes and the exhaust silencer is very hot during this time. During certain driving situations, e.g. if the speed is low and the exhaust temperature is high, the temperature of the silencer can be extremely high. In such cases the symbol "High temperature, exhaust system" is shown in the display. Avoid driving or stopping the truck at an unsuitable place, i.e. in a tunnel, across a field, or close to inflammable material or gases.

If your driving style is such that an accumulation of soot particles occurs, the blue information lamp "INFO" will light and the symbol for soot/ash in the filter will be displayed. As long as these icons are not shown, there is no reason to change your driving style.



**Caution!**

Avoid driving or stopping the truck at an unsuitable place when the symbol "High temperature, exhaust system" is shown in the display.



J3014366



J3018100

## Manual regeneration of the particulate filter

During certain driving situations, regeneration is not initiated automatically. It can be due to situations such as continuous driving (several hours) at low engine load or continuous idling. In these cases it may be necessary to start regeneration manually.

When the regeneration process must be started manually, this is shown on the display as below.





**Caution!**

Make sure that the truck is in a suitable place when regeneration starts.

Indication in the display		Cause	Action
Symbol	Message		
	Regeneration needed	The particulate filter almost full	<ul style="list-style-type: none"> <li>• Drive on a motorway to allow regeneration, or</li> <li>• Start manual regeneration the next time the truck stops at a suitable place</li> </ul>



## 302 Exhaust cleaning

Indication in the display		Cause	Action
Symbol	Message		
 Flashes	Regeneration required	Particulate filter full	<ul style="list-style-type: none"> <li>• Hold motorway speed so that regeneration starts automatically, or</li> <li>• Start manual regeneration the next time the truck stops at a suitable place</li> </ul>
 Flashes	ATS requires service	Particulate filter overfilled. Engine derated.	Stop <b>the truck immediately</b> in a suitable place and start regeneration manually.
 Flashes	ATS requires service	There is a serious fault in the engine. The particulate filter may be working above its maximum capacity. Engine derated.	Stop the truck <b>immediately</b> and contact your nearest Volvo workshop.

### Ash level high in particulate filter

If your driving style is such that an accumulation of ash particles occurs, the information lamp "INFO" will light and the symbol for soot/ash in the filter will be displayed together with the message "Ash level high".

When the information lamp and symbol light: Contact a Volvo workshop for service of the particulate filter within 1-2 weeks.



J3014366



J3018100

## Air suspension equipment

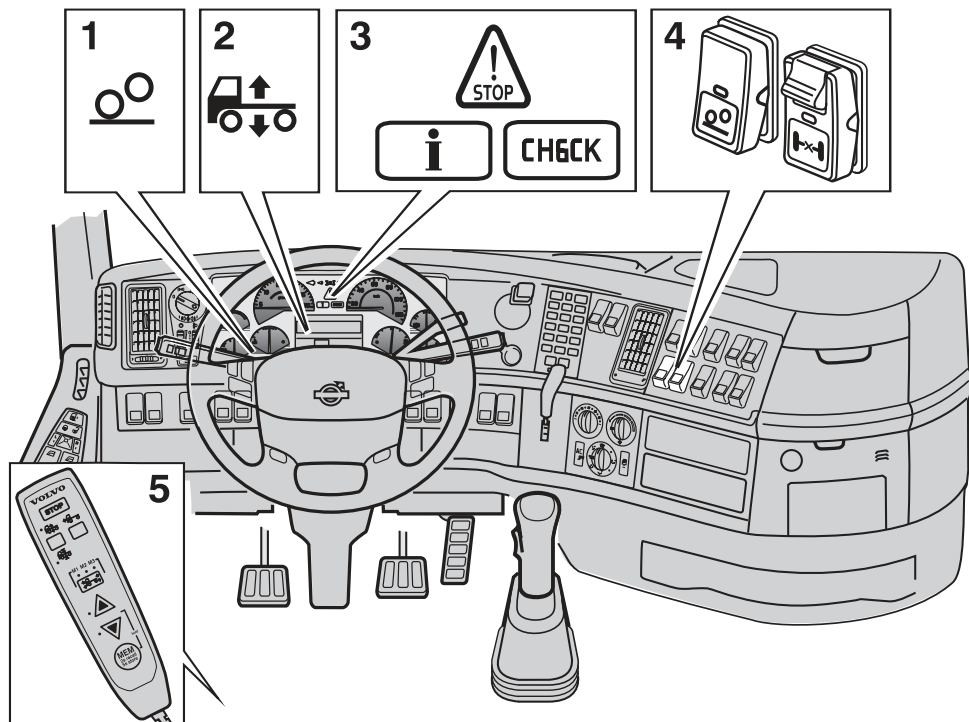

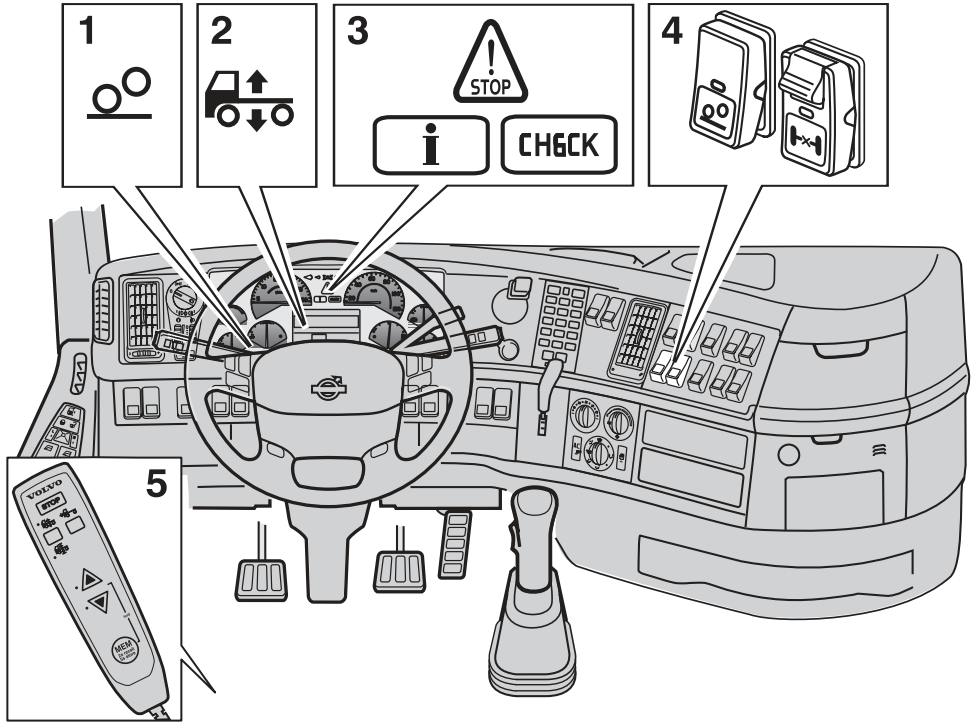

J7009829

- 1 Bogie lift lamp
- 2 Driver display
- 3 Information and warning lamps
- 4 Diff lock switch and bogie switch
- 5 Remote control box

## Remote control box

More information about how the air suspension and control box can be used will be found in chapters "Driving" and "Loading and unloading".

Road speed must be lower than 30 km/h when the control box is used.

## Control buttons

To specify air suspension function:

- 1 STOP, cancels regulation.
- 2 Drive position, for normal driving.
- 3 Manual control.

Changing ride height.

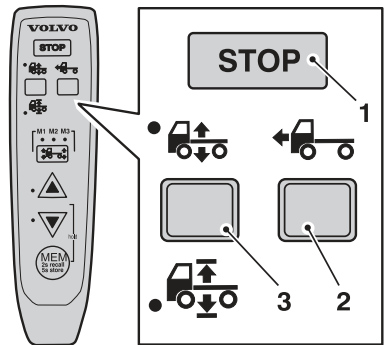

J7009817

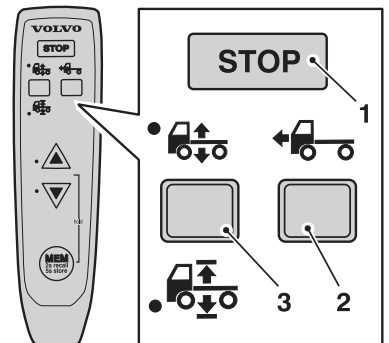

J7009830

## Axle button

To specify which axle is to be adjusted or which memory is to be used:

- M1, front axle or memory 1.
- M2, front and rear axle or memory 2.
- M3, rear axle or memory 3.

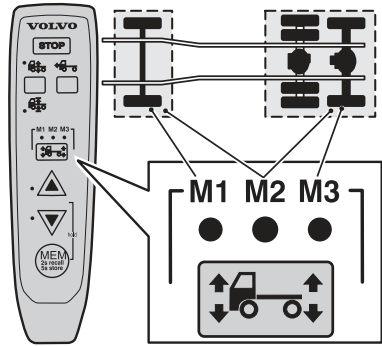

J7009818

## Control buttons

To raise or lower the truck.

To avoid having to hold in the control button, for example when raising or lowering the truck to its highest or lowest height, activate the hold function. Press one of the control buttons and at the same time press the memory button. To cancel the hold function, press the memory button again, one of the control buttons, or STOP.

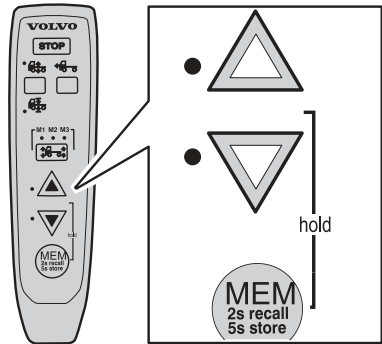

J7009819

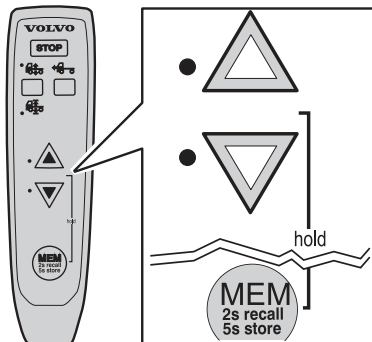

J7009831

## Memory button

To store or retrieve the memory content.

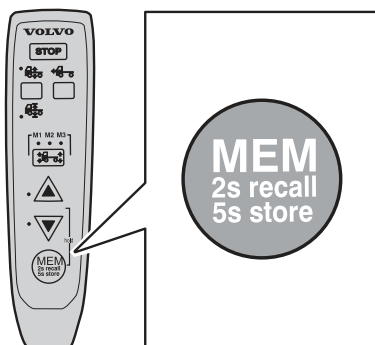

J7009820

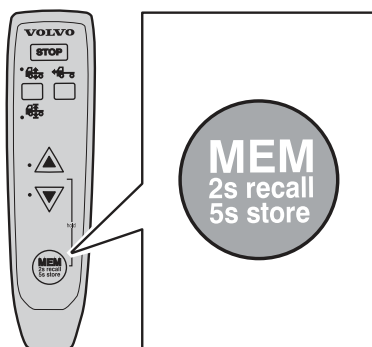

J7009832

## Lamps and symbols

### Bogie lamp

The tag axle raise lamp is lit when:

- The bogie axle is lifted
- Load distribution between the drive axle and bogie axle is changed



J3014468



The bogie lift lamp lights when the load distribution between the drive axle and bogie axle is changed.

Bogie lift lamp

The bogie lift lamp flashes when:

- The drive axle load has increased by 30% on vehicles which have a bogie button with a spring loaded lower position.

### Symbols for air suspension

Symbol	Meaning	Action
	The control button is set to manual control or adjustment of ride height.	Select ride height <b>Note!</b> Drive very carefully when the symbol is displayed.
	If the control button is in the centre position the air suspension is in locked position.	Check whether the air suspension is locked: Turn the ignition key to the stop position (0) and then back to the drive position (I). If the symbol remains on the display the air suspension is locked. See section "Air suspension in locked position", page 628.
Axle load distribution 70%	With "optimise traction", the axle load distribution is shown in the display.	None. The message disappears when optimal load distribution has been achieved.
	Truck not in drive position.	Check that the control button is in the drive position and wait until the truck reaches the correct drive height. <b>Note!</b> Drive very carefully when the symbol is displayed. A signal will sound if the speed is too high. If a bellows is punctured, drive, at not more than 30 km/h, to a Volvo workshop, or contact Volvo Action Service.

Symbol	Meaning	Action
CHECK THE AIR SUSPENSION AT THE NEXT STOP	There is an air suspension malfunction.	Check whether the fault is active at the next stop: Turn the ignition key to the stop position (0) and then back to the drive position (I). If the message remains in the display, the fault is active. See section "Air suspension in locked position".

## Seats

### Driver's seat

#### Overview

- 1 Using memories
- 2 Move or decline seat cushion lengthwise
- 3 Move whole seat up or down and lengthwise
- 4 Heating and Ventilation  
Use position one for maintaining the correct climate comfort and position 2 for quickly reaching the correct climate comfort.
- 5 Upper part: reclines the upper part of the backrest  
Lower part: reclines the whole of the backrest
- 6 Adjust the lumbar support and side support

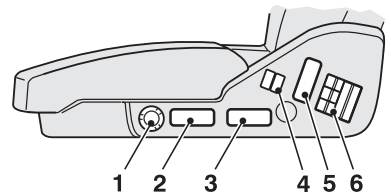

J0010242

#### Damping:

The hardest setting corresponds to a fixed seat.

#### Store a position in the memory

- 1 Adjust the seat
- 2 Choose memory 1, 2 or 3 by turning button 1 to position 1, 2 or 3.
- 3 Depress button 1 until it sounds  
The position is stored.

#### Retrieving a position from the memory

- 1 Choose memory 1, 2 or 3 by turning button 1 to position 1, 2 or 3.



# 310 Cab

---

- 2 Depress button 1 once  
The seat will revert to the stored position.

## Overview

- 1 Move the seat cushion lengthwise
- 2 Move the whole seat lengthwise
- 3 Damping  
The hardest setting corresponds to a fixed seat.
- 4 Seat tilt
- 5 Move the whole seat up or down  
On seats without suspension, the control acts as a lock. To lower the seat, release the lock and remain seated. To raise the seat, stand up and release the lock.
- 6 Heating (extra equipment)
- 7 Lumbar support
- 8 Ventilation (extra equipment)  
Use position one for maintaining the correct climate comfort and position 2 for quickly reaching the correct climate comfort.
- 9 Reclines the upper part of the backrest
- 10 Recline the whole of the backrest

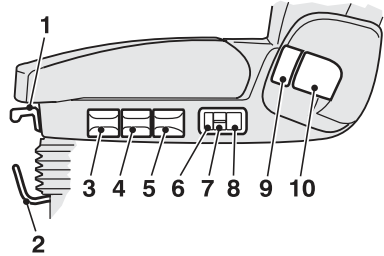

J0010243

## Overview

- 1 Not used
- 2 Move the whole seat lengthwise
- 3 Damping  
The hardest setting corresponds to a fixed seat.
- 4 Seat tilt
- 5 Move the whole seat up or down  
On seats without suspension, the control acts as a lock. To lower the seat, release the lock and remain seated. To raise the seat, stand up and release the lock.
- 6 Not used
- 7 Lumbar support
- 8 Not used

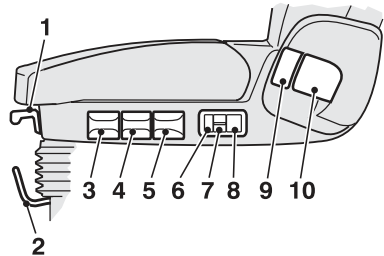

J0010243

- 9 Not used
- 10 Recline the whole of the backrest

## Passenger seat

Insert the belt in the seat on both sides of the passenger (A).

Change the angle of the seat with B.

### Move the seat forward

- 1 Remove the seat belt
- 2 Fold the seat back
- 3 Lift the brace (C)
- 4 Push the seat as far as it will go
- 5 If required change the angle of the backrest

Slide the seat back as in points 3 - 5.

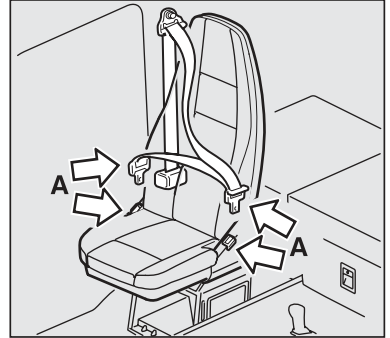

J0010244

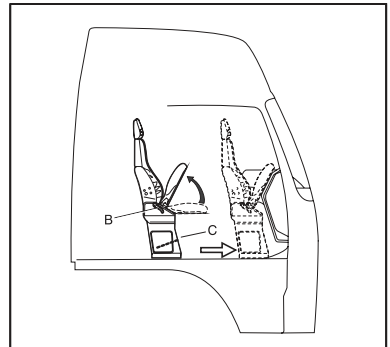

J0009275

## Relax seat

The relax seat can be rotated 90°. To rotate the seat, the backrest must be in the upright position and the seat moved forward.

### Overview

- 1 Recline the complete backrest
- 2 Recline the upper part of the backrest
- 3 Heat(Extra equipment)
- 4 Recline the seat
- 5 Move the whole seat lengthwise
- 6 Move the whole seat lengthwise
- 7 Rotate the seat
- 8 Recline the complete backrest

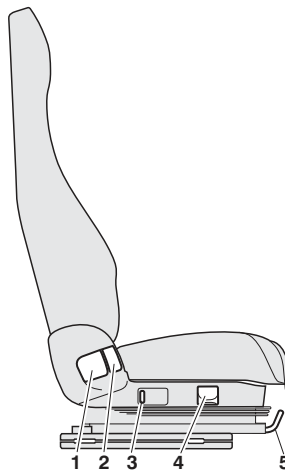

J155258

### Rotating the relax seat

- 1 Put the backrest in the upright position
- 2 Slide the seat to the forward position
- 3 Rotate the seat using lever 7

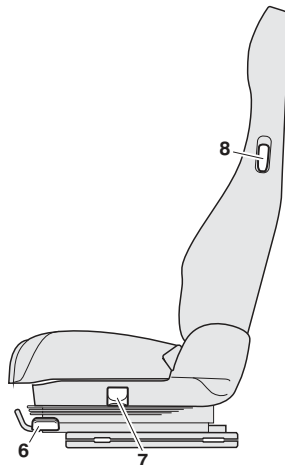

J155277

 **Warning!**

When the seat is rotated, it may obscure the driver's view in the rear view mirrors. Therefore, do not drive the truck with the relax seat rotated.

## Adjusting the steering wheel

First adjust the seat.

- 1 Depress the foot pedal shown by the arrow.
- 2 Adjust the steering wheel vertically and horizontally and adjust its angle.
- 3 Release the pedal, and the steering wheel is locked in its new position.

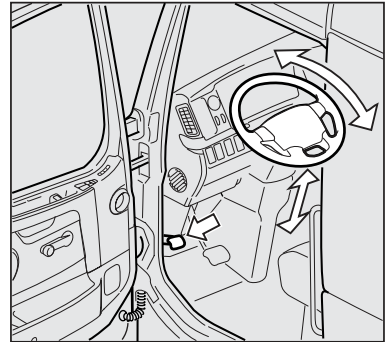

J0010228

## Doors

### Opening and locking doors

Push the lever back to open the door. Push the lever forward to lock the door.

To unlock the passenger door from the driver's door

- 1 Push the lever backwards
- 2 Push the lever forward to the locked position
- 3 Push the lever backwards

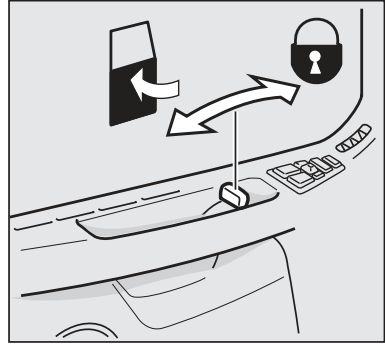

J8008392



### Warning!

The doors should be unlocked while driving! If an accident occurs, rescue teams must be able to enter the truck quickly.

Press on button 2 to lock both doors or to unlock the passenger door only.

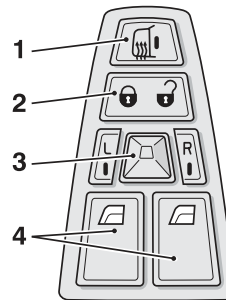

J8008391

## Electrically heated mirrors

Press once on button 1 to start electrical heating for 30 minutes. The indication lamp in the button flashes.

Heating stays on for 30 minutes.

Hold button 1 in longer than 1 second to start the electrical heating. The lamp in the button lights. The heating is on until the engine is switched off.

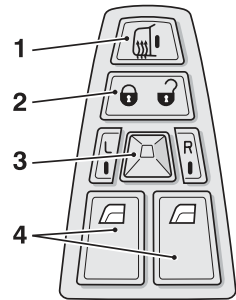

J8008391

## Electrically operated driving mirrors

- 1 Select which mirror is to be adjusted with the buttons at 3  
L for the left side mirror and R for the right side mirror.  
The lamp in the button lights.
- 2 Adjust the mirror with lever 3

The lamp in the button goes out after 10 minutes. Further adjustment requires the mirror to be selected again.

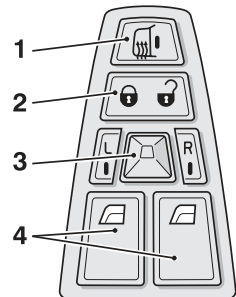

J8008391

## Electric window lifts

### Open window (Auto-down)

- 1 Press and hold the switch in the down position (2) for 1 second
- 2 Release the switch
- 3 The window opens

The window stops when it is completely open or when the down position (2) on the switch is depressed again or when the up position (1) on the switch is depressed.

Make small adjustments with short pushes on the switch.

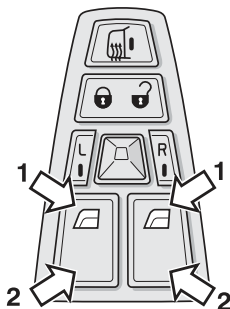

J0010218

### To close the window

Depress the up position (1) on the switch until the window is completely closed.

## Central locking

### To unlock with the transmitter

#### To unlock the driver's door

Press the UNLOCK symbol to unlock.  
The indicators will flash

#### To unlock the passenger door

- 1 Unlock the driver's door with UNLOCK  
The indicators will flash
- 2 Press the UNLOCK symbol once more  
The indicators will flash

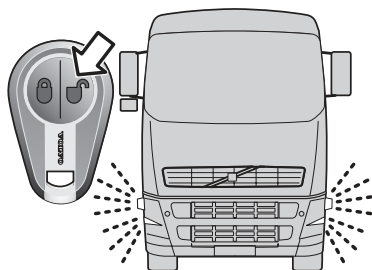

J3017438

## To lock with the transmitter

Press the LOCK symbol  
The indicators light up

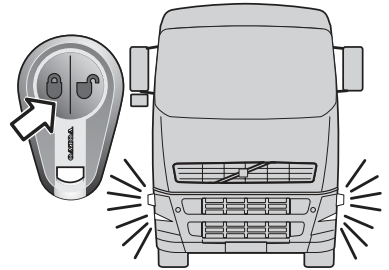

J3017345

## To unlock with the key

- 1 Unlock  
A door is unlocked
- 2 Lock
- 3 Unlock again  
Both doors are unlocked

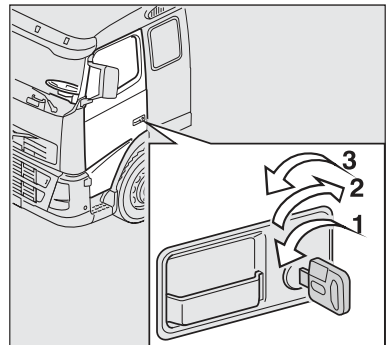

J8008535



## Main switch

### Switch on the main switch.

Press the UNLOCK symbol to unlock

or

Put the ignition key in the lock

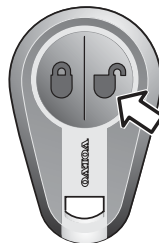

J3017346

### Switch off the main switch

1 Press the LOCK symbol to lock the door

2 Press the LOCK symbol twice  
The main power is switched off



J3017347

## Air conditioning ECC (Electronic Climate Control)

The AC does not function at low outer temperatures or if the fan is turned off. Several external factors can affect the system's function, e.g. persons with damp clothing in the cab, open windows, the sun shining on the cab temperature sensor or if the sensor is covered.

- 1 Turn off air conditioning. The lamp in the switch lights when the air conditioning is turned off.
- 2 Temperature
- 3 Fan speed
- 4 Recirculation
- 5 Air distribution
- 6 Cab temperature sensor

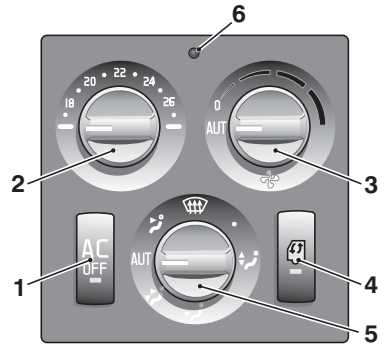

J200692

## Recirculation

Press recirculation to circulate the air within the cab. The function is used to shut out poor air. The ECC controls the recirculation hatch automatically to improve the cooling performance

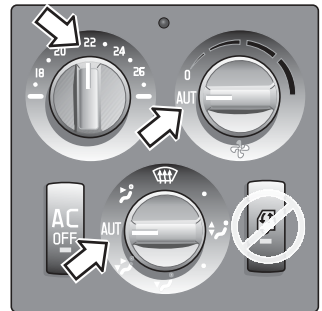

J200696

The lamp in the button lights when air recirculates in the cab.

### Note!

Do not use recirculation with high humidity, heavy rain, low outside temperatures or if the parking heater is running. It is necessary to draw in new air and have the AC on to prevent the windscreen from misting up.

## Air distribution

Always leave the panel nozzles (1) open. Irrespective of how the air distribution is set, a small amount of air will always come from the panel nozzles to ensure that the temperature distribution in the cab is correct.

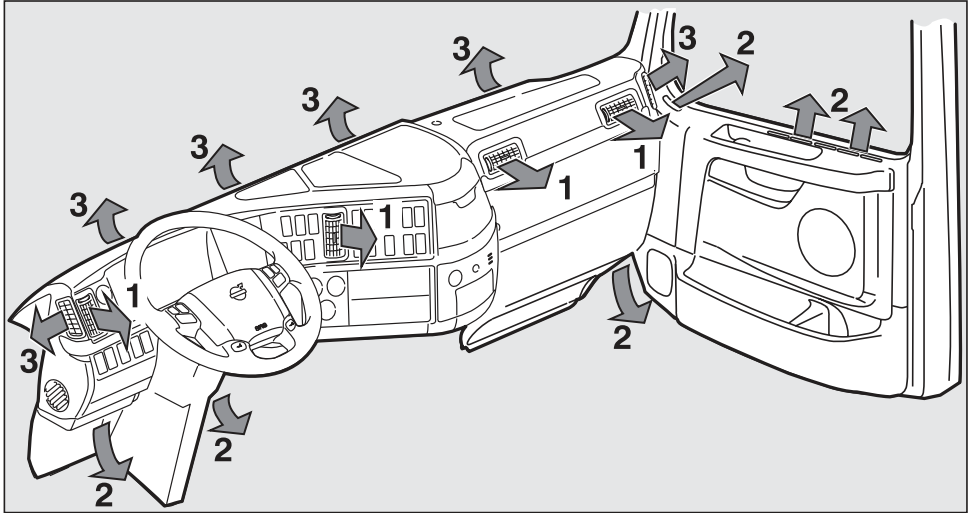

J8010781

1 Panel



2 Floor



3 Defrost



The normal air distribution provides slightly warmer air to the feet and cooler air to the head. This is to create a good working environment for the driver.

## Setting the desired temperature

- Open all the ventilation nozzles
- Set the fan (3) to AUT
- Set air distribution (5) to AUT
- Set desired temperature (2)

In order to rapidly reach the desired temperature with changes, a temporary, extreme increase or decrease of temperature is made, at the same time as the fan speed is increased.

The set temperature cannot be measured using a normal thermometer. The AC takes into account, among other things, the outside temperature and sometimes speed. The temperature on the control is therefore the experienced temperature and not that which a normal thermometer would register.

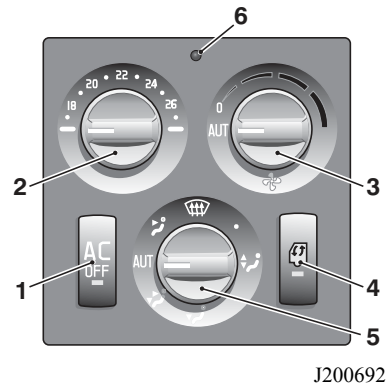

## As cool as possible

- Open all the ventilation nozzles
- Set the fan to AUT
- Set the air distribution in AUT
- Set the temperature as cold as possible

When the temperature control is at an end position and the fan is set to AUT, the system will provide the maximum fan speed.

When it is hot outside, it is normal that water drips from the truck. This is harmless condensation coming from the air conditioning.

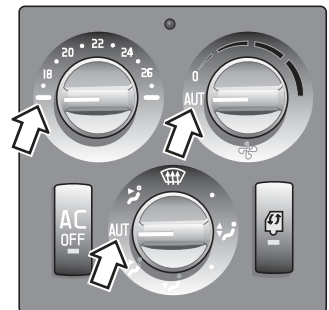

## As warm as possible

- Open all the ventilation nozzles
- Set the fan to AUT
- Set the air distribution in AUT
- Set the temperature to maximum heat

When the temperature control is at an end position and the fan is set to AUT, the system will provide the maximum fan speed.

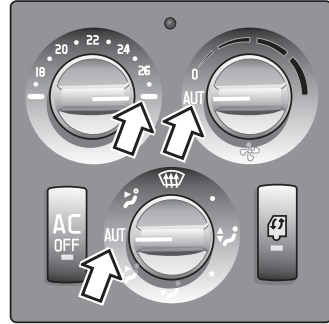

J200702

## Remove mist and ice from windows

- Check that recirculation is turned off
- Set the fan to AUT
- Set the air distribution to defroster
- Set the temperature to maximum heat or the fan to max

In AUT/defrost mode with cold outdoor temperatures, the windscreen can become so warm that snow smoke melts on it. This can cause the wiper blades to freeze to the windscreen. Set the air distribution to the floor only. The floor setting can also be used together with the defroster to remove mist from the side windows.

Clean the inside of the windscreen with a normal window cleaning fluid to reduce the risk of misting up. Clean more frequently if someone smokes in the cab.

With cold outdoor temperatures, mist and ice can occur on the side windows. To avoid this, close the inner panel nozzles and aim the side nozzles at the side windows.

## Note!

Do not use recirculation with high humidity or heavy rain. It is necessary to draw in new air and have the AC on to prevent the windscreen from misting up. If the defroster has been selected, the AC operates at maximum (except at low temperatures) to dry the air.

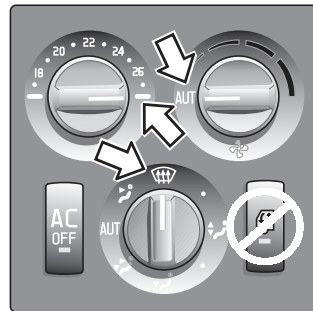

J200699

## Air conditioning MCC (Manual Climate Control)

- 1 Switch on the air conditioning The lamp in the button lights when the air conditioning is on.
- 2 Temperature
- 3 Fan speed
- 4 Recirculation
- 5 Air distribution

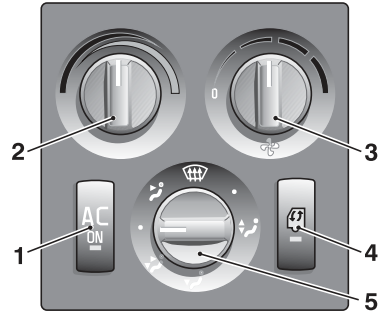

J8008717

## Recirculation

Press recirculation to circulate the air in the cab. Only a small amount of air is then taken from the outside. The function is used to shut out poor air.

The lamp in the button lights when air circulates in the cab.

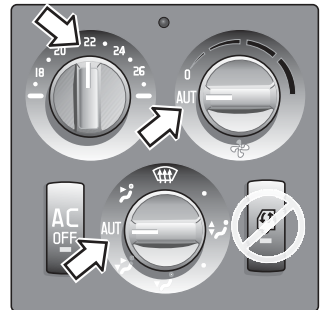

J200696

## Note!

Do not use recirculation with high humidity, heavy rain, low outside temperatures or if the parking heater is running. It is necessary to draw in new air and have the AC on to prevent the windscreen from misting up.

## Air distribution

Always leave the panel nozzles (1) open. Irrespective of how the air distribution is set, a small amount of air will always come from the panel nozzles to ensure that the temperature distribution in the cab is correct.

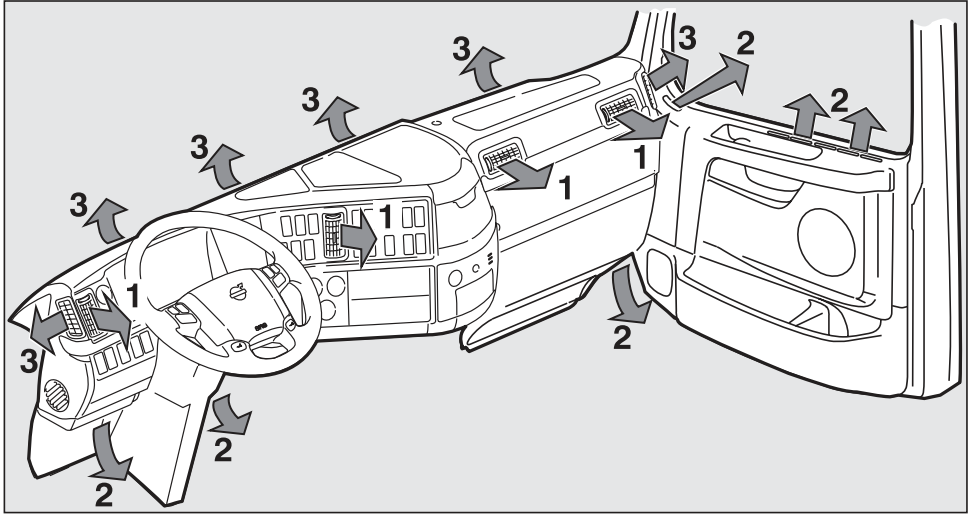

J8010781

1 Panel



2 Floor



3 Defrost



## Setting the desired temperature

- Open all the ventilation nozzles
- Turn on the fan (3)
- Set desired air distribution (5)
- Set desired cooling or heating (2)
- If necessary, start the air conditioning (1)

When it is hot outside, it is normal that water drips from in the truck. This is harmless condensation coming from the air conditioning.

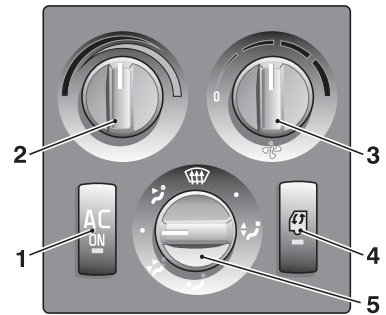

J8008717

## Remove mist and ice from windows

- Check that recirculation is turned off
- Set the fan to the highest possible speed
- Set the air distribution to defroster
- Set the temperature to maximum heat or the fan to max

In AUT/defrost mode with cold temperatures, the windscreen can become so warm that snow smoke melts on it. This can cause the wiper blades to freeze to the windscreen. Set the air distribution to the floor only. The floor setting can also be used together with the defroster to remove mist from the side windows.

Clean the inside of the windscreen with a normal window cleaning fluid to reduce the risk of misting up. Clean more frequently if someone smokes in the cab.

With cold outdoor temperatures, mist and ice can occur on the side windows. To avoid this, close the inner panel nozzles and aim the side nozzles at the side windows.

### Note!

Do not use recirculation with high humidity or heavy rain. It is necessary to draw in new air and have the AC on to prevent the windscreen from misting up.

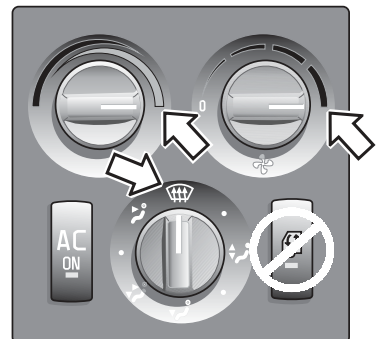

J200694



## Climate control system HEAT

- 1 Temperature
- 2 Air distribution
- 3 Recirculation
- 4 Fan speed

### Recirculation

Move the control (3) to the lower position. Only a small amount of air is then taken from the outside.

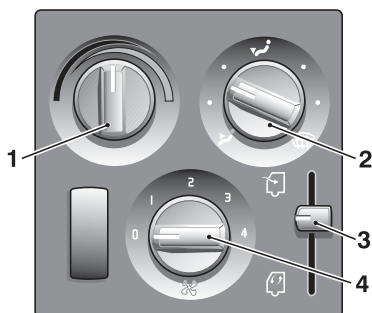

J8009986

### Air distribution

Always leave the panel nozzles (with arrows) open. Irrespective of how the air distribution is adjusted, a small amount of air will come from the panel nozzles to ensure that the temperature in the cab is correct.

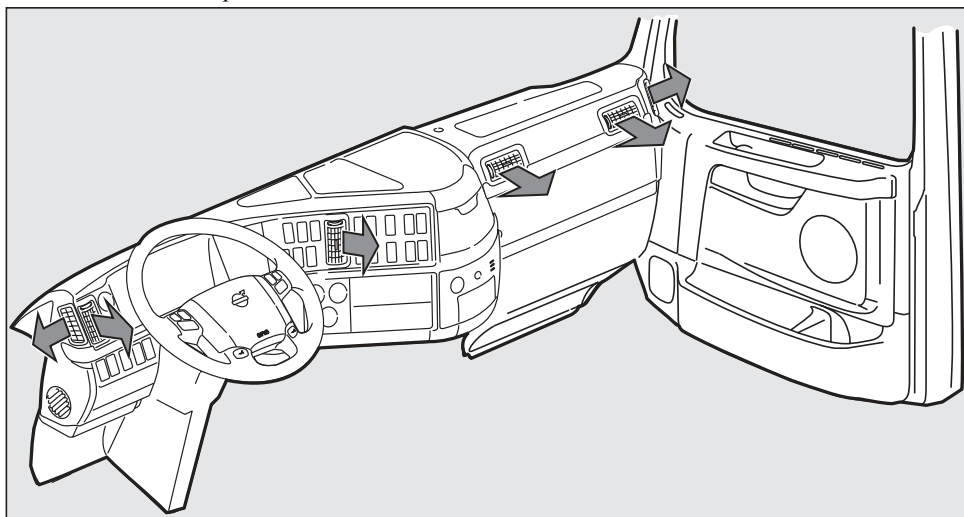

J8008612

## Setting the desired temperature

- Open all the ventilation nozzles
- Turn on the fan (4)
- Set desired air distribution (2)
- Set desired cooling or heating (1)

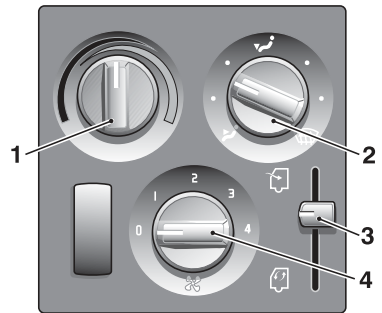

J8011876

## Remove mist and ice from windows

- Open all the ventilation nozzles
- Set the fan to the highest possible speed
- Set the air distribution to defroster
- Set the temperature to maximum heat

In AUT/defrost mode with cold temperatures, the windscreen can become so hot that snow smoke melts on it. This can cause the wiper blades to freeze to the windscreen. Set the air distribution to the floor only.

Clean the inside of the windscreen with a normal window cleaning fluid to reduce the risk of misting up. Clean more frequently if someone smokes in the cab.

With cold outdoor temperatures, fogging and ice can occur on the side windows. To avoid this, close the inner panel nozzles and aim the side nozzles at the side windows.

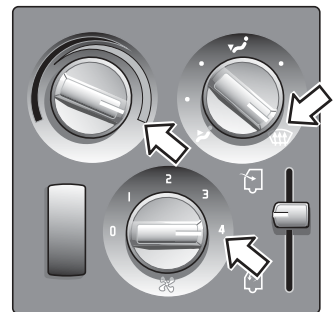

J8011877

## Cab heater PH-CAB

### Start the heater

#### ADR

On ADR vehicles, the parking heater will not start if the power take-off is engaged.

**1** Check that the combustion air and exhaust openings are not blocked.

#### **Note!**

The heater must be shut off when fuelling.

#### **Note!**

The main switch must not be turned off before the heater has stopped.

**2** Open the panel vents

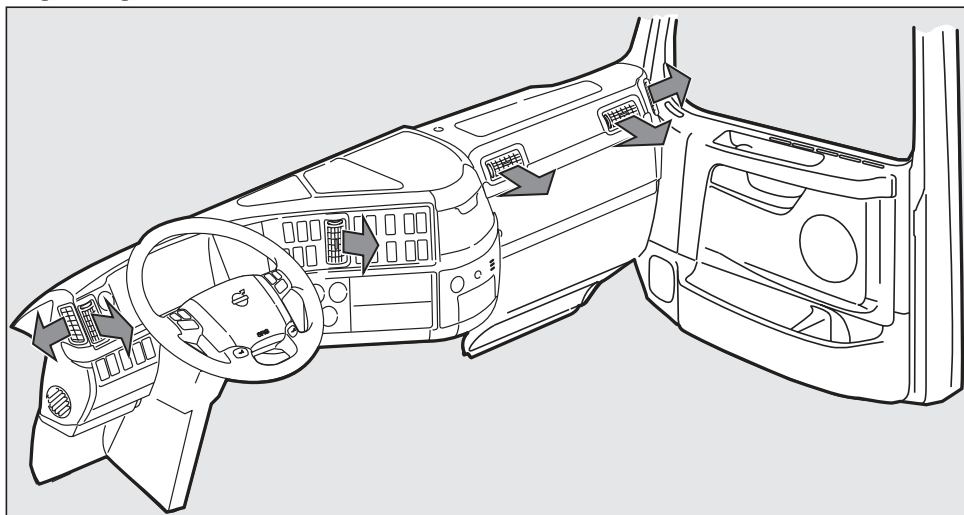

**3** Turn off recirculation.



J200695

**4** Hold the switch in until the LED in the switch lights. The heater starts and continues to run for 10 hours or until it is manually switched off.

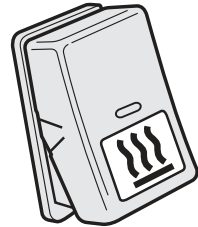

J8008457

**5** Set the temperature with the thermostat. The green indicator lamp lights up when the heater is switched on.

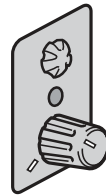

J8008250

## Start the heater with timer setting

### ADR

ADR trucks do not have a time delay start function.

Setting is carried out via the driver's display. It is only possible to set a start time when the truck is stationary. (Refer to “Driver's instructions, Display” for information about how the display works.)

**1** Check that the combustion air and exhaust openings are not blocked.

**2** Open the panel vents

# 330 Cab

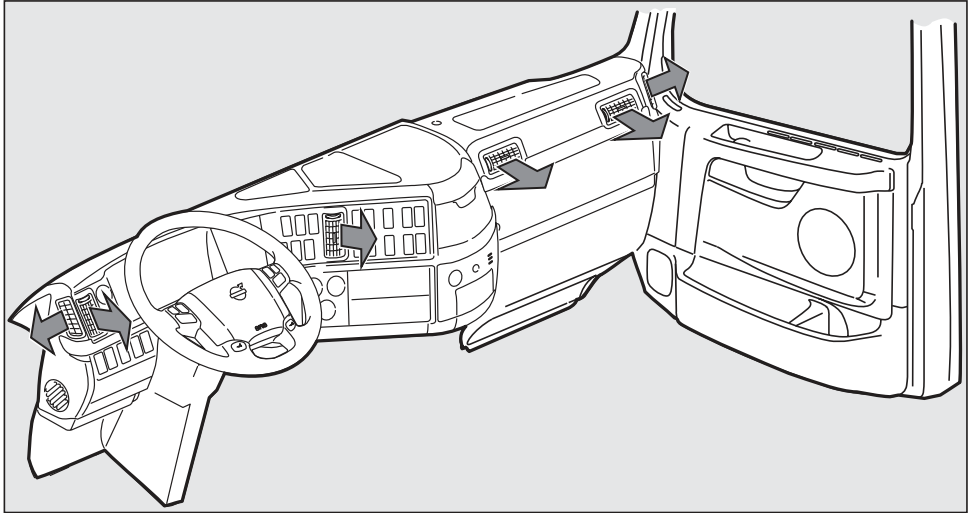

J8008612

**3** Turn off recirculation.



J200695

**4** Select menu "P-heater timer"

**5** Select "Programming"

**6** Set the start date

**7** Set the start time

**8** Set the length of time the heater should be switched on (max two hours)

**9** Check that the settings are correct.

If they do not correspond, begin again or go backwards in steps with ESC.

**10** When the settings are correct, press "SELECT" to confirm the settings and to return to the previous menu.

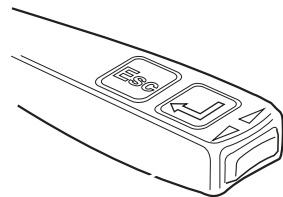

1

2

3

4

Delete the settings by entering menu "P-heater timer" and selecting "Zero".

**11** Set the temperature with the thermostat.

The green indicator lamp lights up when the heater is switched on.

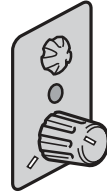

J8008250

## Turning off the heater

Hold the switch in until the LED in the switch goes out.

The heater is also switched off when the engine is started and when the cooling fluid temperature has become sufficiently high.

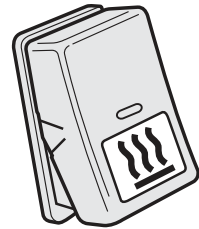

J8008457

## Automatic cut-off

The heater is switched off automatically when

- the flame goes out during operation and does not relight within 90 seconds
- the heater overheats
- the voltage drops below 20 V or increases above 30 V

If the heater stops while running, or will not start at all, check the following:

- fuses
- fuel level in the fuel tank
- underpressure in the fuel tank
- that the air circulation is not blocked

### Note!

The use of biofuel reduces the life of the heater and fuel pump, while increasing the need for servicing by up to 10 times.

Then try to start the heater again. If it stops again, or will not start at all, contact a Volvo workshop (If the heater has stopped or will not start at all because of low fuel level or underpressure in the fuel tank, it may take up to 6 starting attempts before the heater will start).

The heater is switched off automatically when

- the flame goes out during operation and does not relight within 90 seconds
- the heater overheats
- the voltage drops below 20 V or rises above 30 V
- the power take-off is activated

If the heater stops while running, or will not start at all, check the following:

- the fuse
- fuel level in the fuel tank
- underpressure in the fuel tank
- that the air circulation is not blocked

Then try to start the heater again. If it stops again, or will not start at all, contact a Volvo workshop. (If the heater has stopped or will not start at all because of low fuel level or underpressure in the fuel tank, it may take up to 6 starting attempts before the heater will start.)

### Heater maintenance

In order for the heater to be reliable, the parking heater must be run at regular intervals, even in warm temperatures. A symbol and a message are shown in the display when it is time to run it. The parking heater must then be run for at least 20 minutes. Set the heater to maximum. Open the windows and doors if the temperature in the cab gets too high.



## Cab and engine heater PH-ENGCA

### Start the heater

On ADR vehicles, the parking heater will not start if the power take-off is engaged.

**1** Check that the combustion air and exhaust openings are not blocked, and that there is no visible damage to the exhaust or combustion air hoses.

#### **Note!**

The heater must be shut off when fuelling.

#### **Note!**

The main switch must not be turned off before the heater has stopped.

**2** Open the panel vents

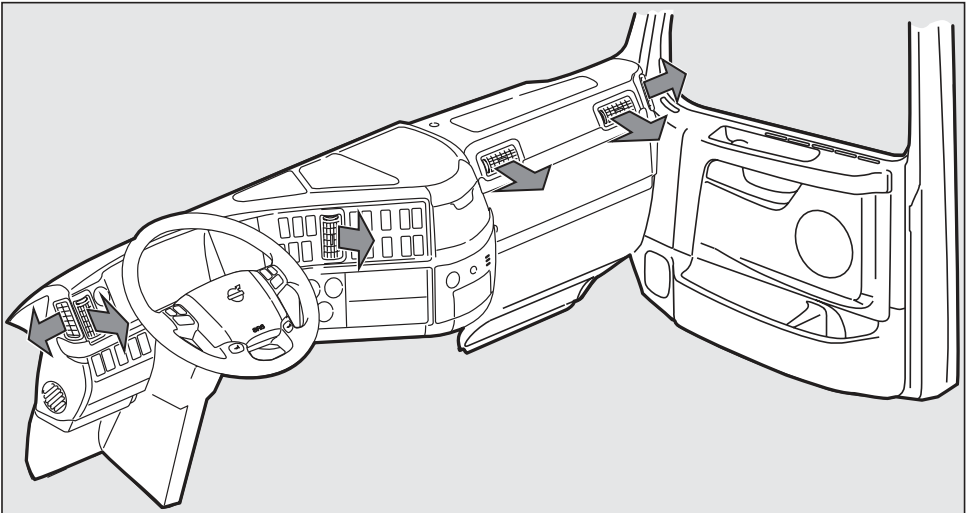

J8008612



## ECC

3 Set the air conditioning:

- Recirculation off
- Fan to AUT
- Air distribution to AUT
- Desired temperature

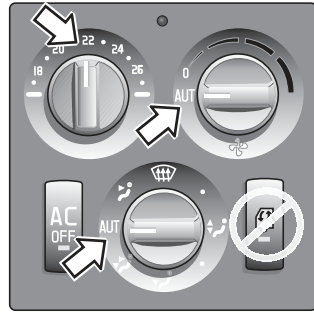

J200696

## MCC

3 Set the climate control:

- Recirculation off
- Fan in position 0 or 1
- Air distribution to panel vents and floor
- Temperature at MAX

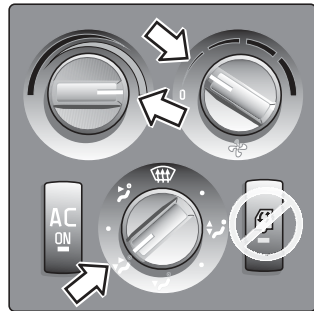

J8011833

### Note!

With cold temperatures, the fan knob may need to be set to position 2 or 3.

## HEAT

3 Set the climate control:

- No recirculation
- Fan in position 0 or 1
- Air distribution to panel vents and floor
- Temperature at MAX

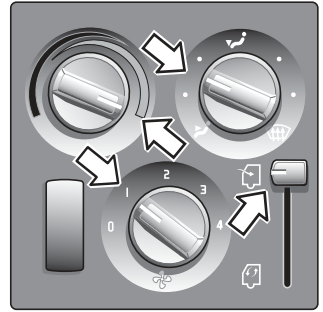

J8011834

### Note!

With cold temperatures, the fan knob may need to be set to position 2 or 3.

4 Hold the switch in until the LED in the switch lights. The heater starts and continues to run for 10 hours or until it is manually switched off.

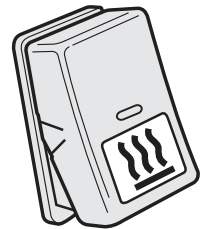

J8008457

## MCC & HEAT

5 Set the temperature with the thermostat. The green indicator lamp lights up when the heater is switched on and the cab fan is running (warming-up phase).

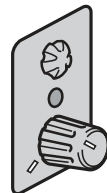

J8008250

**Note!**

The heater can be used as a supplement for cold starts, to raise the cab temperature faster.

**Start the heater with timer setting**

ADRtrucks do not have a time delay start function.

Setting is carried out via the driver's display. It is only possible to set a start time when the truck is stationary. (Refer to the "Display" section for information about how the display works.)

**1** Check that the combustion air and exhaust openings are not blocked.

**2** Open the panel vents

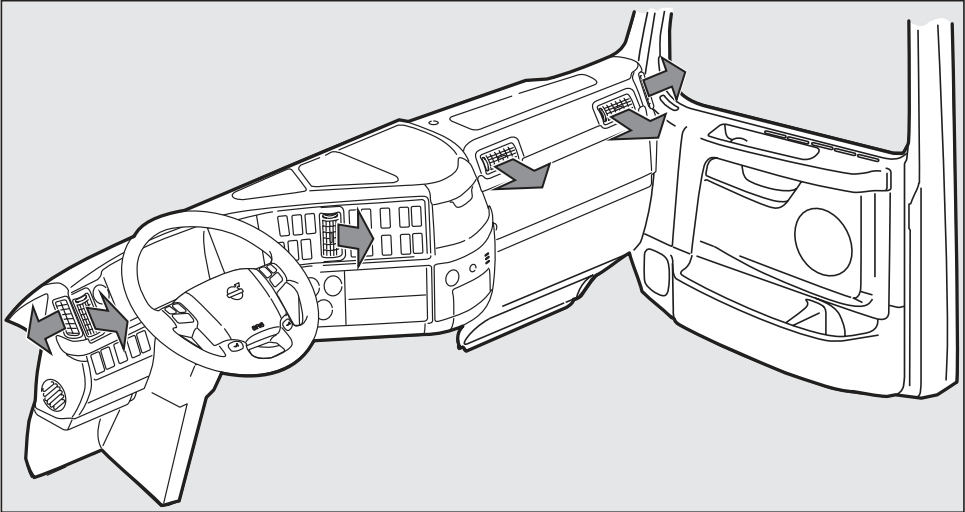

## ECC

3 Set the climate control:

- Recirculation off
- Fan to AUT
- Air distribution to AUT
- Desired temperature



J200696

## MCC

3 Set the climate control:

- Recirculation off
- Fan in position 0 or 1
- Air distribution to panel vents and floor
- Temperature at MAX



J8011833

### Note!

With cold temperatures, the fan knob may need to be set to position 2 or 3.

## HEAT

3 Set the climate control:

- No recirculation
- Fan in position 0 or 1
- Air distribution to panel vents and floor
- Temperature at MAX

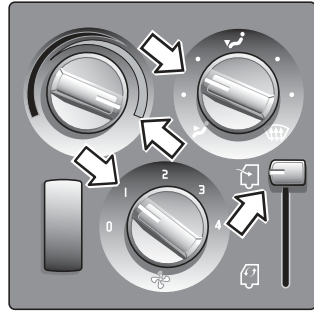

J8011834

### Note!

With cold temperatures, the fan knob may need to be set to position 2 or 3.

4 Select menu "P-heater timer"

5 Select "Programming"

6 Set the start date

7 Set the start time

8 Set the length of time the heater should be switched on (max two hours)

9 Check that the settings are correct.

If they do not correspond, begin again or go backwards in steps with ESC.

10 When the settings are correct, press "SELECT" to confirm the settings and to return to the previous menu.

Delete the settings by entering menu "P-heater timer" and selecting "Zero".

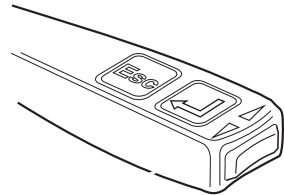

## MCC & HEAT

11 Set the temperature with the thermostat. The green indicator lamp lights up when the heater is switched on and the cab fan is running (warming-up phase).

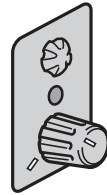

J8008250

## Start engine heater only

### ECC

Start the heater as normal, but set the temperature control to blue, the coldest available. The cab will not be heated, only the engine.



J200697

### MCC

Turn the thermostat to its lowest position.



J200698

## HEAT

Turn the thermostat to its lowest position.



J200698

## Turning off the parking heater

Depress the switch until the LED in the switch goes out.

The heater is also switched off when the engine is started and the coolant has become sufficiently warm.

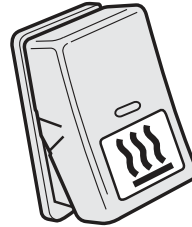

J8008457

## If the heater stops

The heater is switched off automatically when

- the flame goes out during operation and does not relight within 90 seconds
- the heater overheats
- the voltage drops below 20 V or rises above 30 V
- combustion has not started after two start attempts
- the power take-off is engaged or the engine stops

If the heater stops while running, or will not start at all, check the following:

- the fuse
- fuel level in the fuel tank
- underpressure in the fuel tank
- that the air circulation is not blocked

## Note!

The use of biofuel reduces the service life of the heater and fuel pump, and increases the need for servicing by up to 10 times.

Then try to start the heater again. If it stops again, or will not start at all, contact a Volvo workshop. (If the heater has stopped or will not start at all because of low fuel level or underpressure in the fuel tank, it may take up to 6 starting attempts before the heater will start.)

## Heater maintenance

In order for the heater to be reliable, the parking heater must be run at regular intervals, even in warm temperatures. A symbol and a message are shown in the display when it is time to run it. The parking heater must then be run for at least 20 minutes. Set the heater to maximum. Open the windows and doors if the temperature in the cab gets too high.



## Rest heater SS-HEAT

The rest heater is a pump that continues to circulate hot water from the engine during short rest periods, as long as the engine is hot.

## Start the rest heater

1 Open the panel vents



# 342 Cab

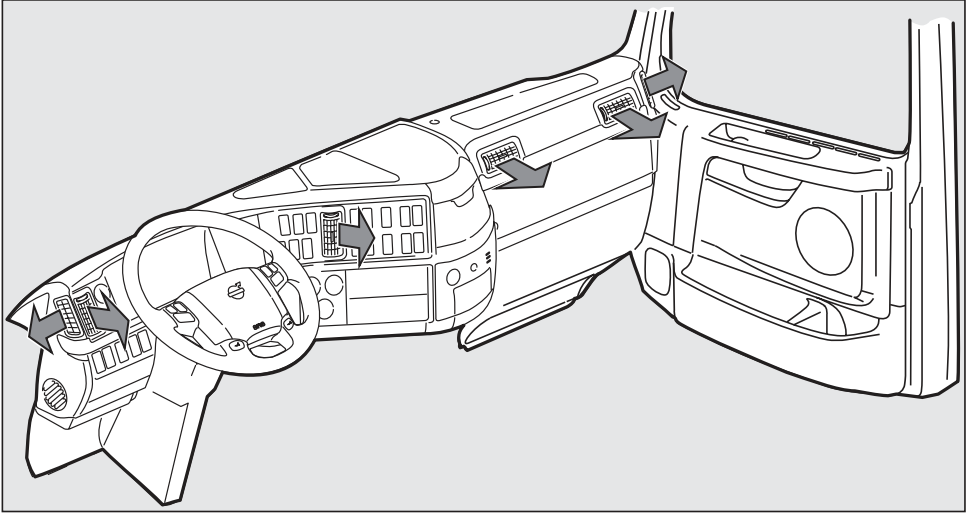

J8008612

2 Hold the switch in until the LED in the switch lights

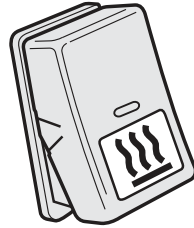

J8008457

## Turning off the rest heater

Depress the switch until the LED in the switch goes out.

The heater is also turned off when the coolant temperature is too low to heat the cab.

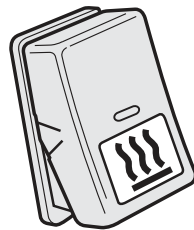

J8008457

## Luggage compartment hatch

### Open the hatch

Pull the cable on the inside of the cab. When the first snap is heard the hatch is still locked. Pull the cable a little more to open the hatch.

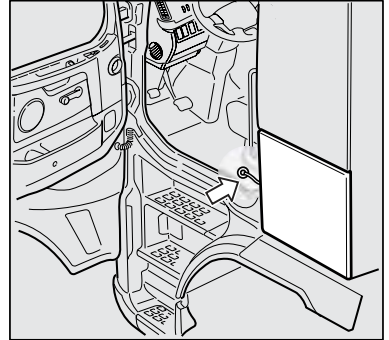

J0010229

### Lighting

To switch off the lights when the hatch is open:  
Hold the door switch and turn clockwise.

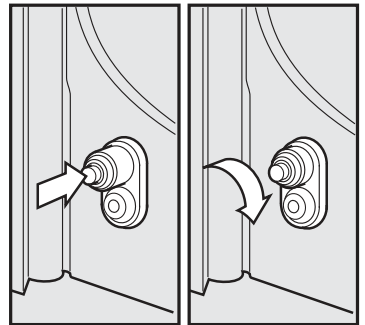

J0008069

## Electrically operated sun roof

### Open the hatch at the rear:

Depress the lower part of the switch.

### To open the entire hatch:

First open the hatch at the rear edge. Then release the switch and depress it again.

### Close the hatch:

Depress the upper part of the switch.

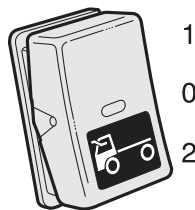

J0009277

## Lighting

The cab lighting can be adjusted by the switches located in the

- Front shelf
- Rear panel

### Switch in front shelf

- 0 OFF
- 1 Door lighting (if the switch in the rear panel is in the 0 position)
- 2 Maximum lighting



J211668

## Switch in rear panel

- 0 The front control adjusts the light
- 1 All lighting OFF (if the switch in the front shelf is not in position 2)



J211668

The cab lighting can be adjusted by the switches located in the

- Instrument panel
- Rear panel

## Switch in instrument panel

- 0 OFF
- 1 Door lighting (if the switch in the rear panel is in the 0 position)
- 2 ON



J211668

## Switch in rear panel

- 0 The front control adjusts the light
- 1 All lighting OFF (if the front switch is not in position 2)

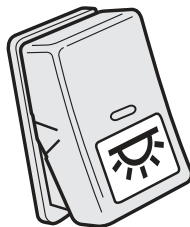

J211668

The cab lighting can be adjusted by the switches located in the

- Front shelf
- Instrument panel
- Rear panel

## Switch in front shelf

- 0 OFF
- 1 Door lighting (if the switch in the rear panel is in the 0 position)
- 2 Maximum lighting



J211668

This switch turns on the night lighting in the front shelf.

- 0 OFF
- 1 ON



J211669

### Switch in instrument panel

Lights the night lighting in the door and in the storage compartment in the instrument panel.

- 0 OFF
- 1 ON



J211669

### Switch in rear panel

- 0 The front control adjusts the light
- 1 All lighting OFF (if the front switch is not in position 2)



# 348 Cab

---

The lighting in the cab can be adjusted by switches located in the

- Front shelf
- Instrument panel
- Rear panel

## Switch in front shelf

Lights the night lighting in the front shelf

- 0 OFF
- 1 ON

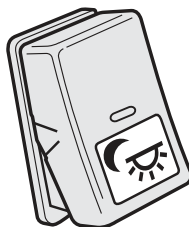

J211669

## Switch in instrument panel

- 0 OFF
- 1 Door lighting (if the switch in the rear panel is in the 0 position)
- 2 ON



J211668

Lights the night lighting in the door and in the storage compartment in the instrument panel.

- 0 Night lighting OFF
- 1 Night lighting ON



J211669

## Switch in rear panel

- 0 The front control adjusts the light
- 1 All lighting OFF (if the front switch is not in position 2)





# 350 Cab

---

The cab lighting can be controlled by the control located above the driver's position. The cab lighting can be adjusted between four positions as required (1-4), in addition the automatic courtesy light can be switched off (5).

- 1 Lighting Off
- 2 Night lighting (red)
- 3 Normal lighting
- 4 Maximum lighting
- 5 Courtesy lighting On/Off

The reading lights can be used for a certain time even when the lighting is switched Off.

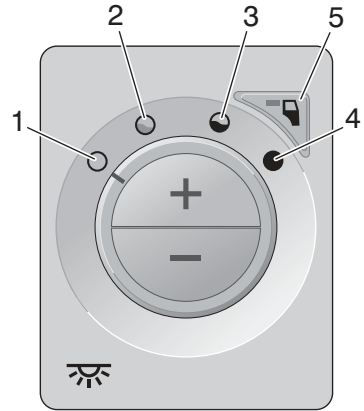

J166564

## Adjusting the lighting

The cab lighting can be dimmed using the + and – buttons. The most recent dimmer setting is saved in the memory.

A specific dimmer level can be set for when the door is open. The most recent level is then saved in the memory.

## Switch in rear panel

The switch in the rear panel works also to switch off / switch on the light.

- 0 The front control adjusts the light
- 1 All lighting OFF (if the front switch is not in position 2)



J211668

## Electrical power outlet

Electrical power outlets (24 V and 12 V) can be found in both the instrument panel and the rear part of the cab. These are intended for extra equipment.

### Note!

The cigarette lighter socket is not intended to be used as a power outlet.

## Bunk bed

Press both buttons at the same time.

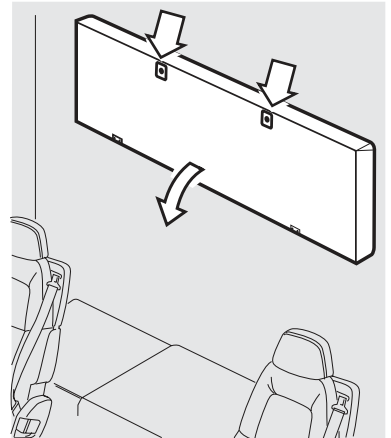

J8008443

Lift the bed slightly and pull the strap (1) down to release the pins and raise or lower the whole bed  
 Make sure the lock pins engage properly in the holes!  
 Press both buttons (2) at the same time to lower the bed.

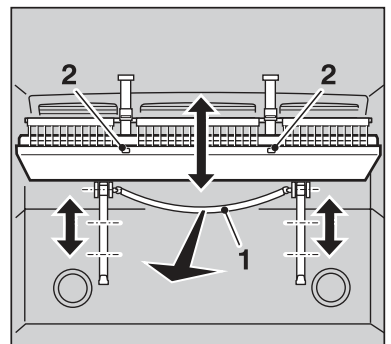

J0010996

## Bed netting for upper bunk

Raise the net if someone is sleeping in the bunk while travelling

Raise the net (3) and fasten with the fixtures (4)

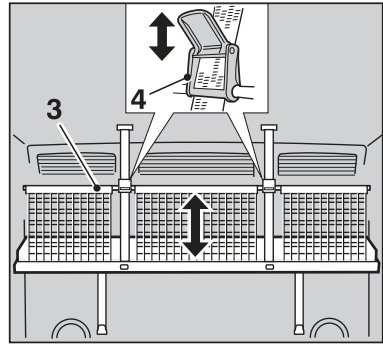

J0010991

## Lower bunk

### Office package

The bed can be transformed into two seats and a table.

- 1 Raise the middle of the mattress as a backrest
- 2 Fold up the table
- 3 Hook the table to the hooks in the wall

The table has marks for mounting the fixing eyes. The fixing eyes can be used together with elastic straps to hold e.g. a laptop computer while travelling.

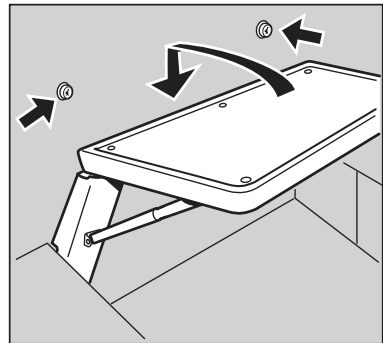

J0010992

### Bed netting for lower bunk

Raise the net if someone is sleeping in the bunk while travelling.

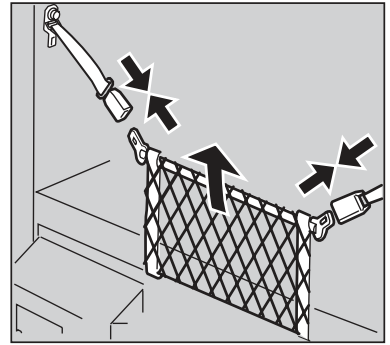

J0010990

### Smoke detector

#### Temporarily switch off the smoke detector

Push the switch once.

The smoke detector is switched off for ten minutes. Use this function when smoking or when driving in a dusty environment. The smoke detector can be switched off both when it is silent and when it is sounding an alarm. When the smoke detector is switched off the lamp lights up every ten seconds. After ten minutes the smoke detector becomes active again.

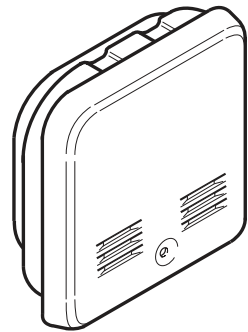

J0008961

## Battery for the smoke detector

When the battery is about to run out a short signal will sound every 45 seconds. Change the battery.

Test the detector at least once every month (battery control) and always after holidays or other long periods of absence.

Check the battery by holding the switch in for 5 - 10 seconds. If the battery is good an alarm will sound for as long as the switch is depressed. When the battery is being checked the detector is switched off for ten minutes.

The detector should be handed in for inspection every 5 years, please contact your Volvo dealer.

## Note!

When the battery is being checked the detector is switched off for ten minutes.

## Tilt the cab

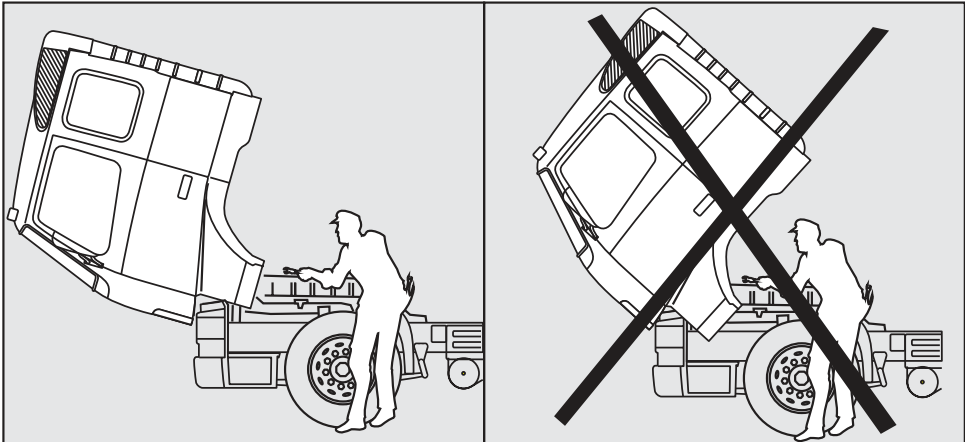

J0008635

 **Warning!**

Completely tilt the cab! It is not permissible to work underneath a cab which is not fully tilted. If the cab cannot be completely tilted, a suitable metal device must be inserted to ensure that the cab cannot fall back again. Never go beneath or in front of a tilted cab.

## Mechanical tilting

### Tilting

- 1 Check that
  - there is sufficient space in front of the cab.
  - the hand-operated parking brake is on.
  - the gear lever is in neutral position.
  - the doors are either completely open or properly shut.
  - the cap on the clutch fluid reservoir is properly closed.
- 2 Fit the socket spanner (3) into the valve of the hydraulic pump (1).
- 3 Turn clockwise to the stop position. The valve is closed.
- 4 Get the pump rod.
- 5 Assemble the lever with the socket spanner (3).
- 6 Place the socket spanner in the pump (2).
- 7 Pump until the cab has reached maximum tilt.

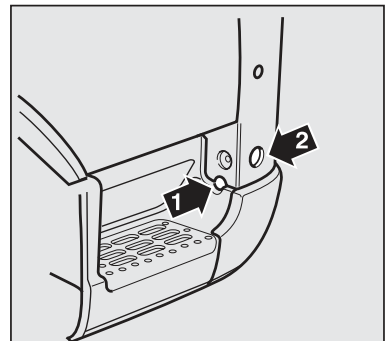

J8008488

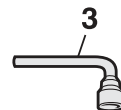

J0008203



J0008202

## Tilting back

- 1 Fit the socket spanner (3) into the valve of the hydraulic pump (1).
- 2 Turn anticlockwise to the stop position. The valve is open.
- 3 Get the pump rod.
- 4 Assemble the lever with the socket spanner (3).
- 5 Place the socket spanner in the pump (2).
- 6 Pump until the cab is locked in the driving position.
- 7 Check that the lamp showing unlocked cab does not light up when the engine is running.
- 8 Put the tools away.



J0008208

Open valve (drive position)



J3014610

Control lamp for tilted cab.

## Electric tilting

### Tilting

- 1 Check that:
  - there is sufficient space in front of the cab.
  - the hand-operated parking brake is on.
  - the gear lever is in neutral position.
  - the doors are either completely open or properly shut.
  - the cap on the clutch fluid reservoir
- 2 Fit the socket spanner (3) into the valve of the hydraulic pump (1).
- 3 Turn clockwise to the stop position. The valve is closed.
- 4 Turn the ignition to the radio position.

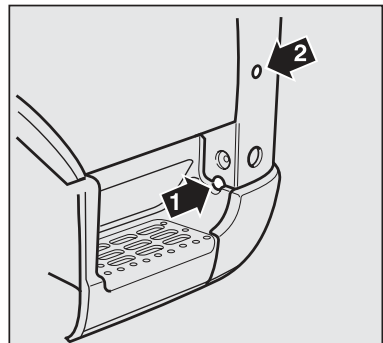

J8008489

- 5 Press in the lower part of the switch.  
The indicator lamp in the switch lights up.
- 6 Fit the socket spanner (3) in the switch (2).
- 7 Turn the switch (2) clockwise to stop.
- 8 Hold the switch (2) in the stop position until the cab is completely tilted.
- 9 Release the switch (2).

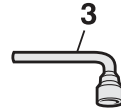

J0008203



J0008202

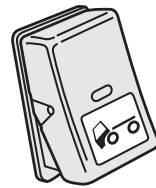

J0008204

## Tilting back

- 1 Fit the socket spanner (3) into the valve of the hydraulic pump (1).
- 2 Turn anticlockwise to the stop position. The valve is open.
- 3 Fit the socket spanner (3) in the switch (2).
- 4 Turn the switch (2) clockwise to stop.
- 5 Keep the circuit breaker (2) in the stop position until the cab has been tilted completely back and is locked in driving position.
- 6 Release the switch (2).
- 7 Check that the lamp showing unlocked cab does not light up when the engine is running.
- 8 Put the tools away.
- 9 Push in the upper part of the switch.



J0008208

Open valve (drive position)

If the cab is tilted electrically more than twice running an overheating protection can be activated. Therefore



## 358 Cab

---

allow the motor in the electric hydraulic pump to cool for 15 minutes. If the pump does not work after 15 minutes check the fuse in the fuse box.

If the electric cab tilting mechanism still does not work the cab can be tilted mechanically. If the cab will not tilt it can be because of air in the system or because the cab is too heavily loaded.

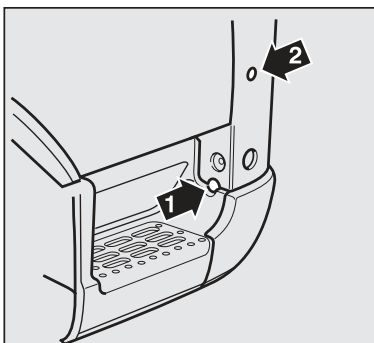

J8008489



J3014610

Control lamp for tilted cab.



J0008204

Switch for electric tilting.

### **Note!**

If the pressure in the cab tilting hydraulic system does not increase, despite pumping, there is probably air in the system.

## To bleed the hydraulic system

- 1 Set the control valve to position "down".
- 2 Pump the hydraulic pump 30 times.
- 3 Tilt the cab.
- 4 Tilt the cab back again.
- 5 Check the oil level.  
The oil should cover the pump piston when the pump piston is in the lower position.



J8006515

### Note!

Never put oil in the hydraulic system when the cab is tilted.

## Mobile telephone, communication equipment

Incorrect connection and installation of accessory equipment or use of portable mobile phones without exterior antennae can influence the truck's electronic system. Always contact your Volvo dealer before mounting accessories.

## Alarm on

Press the LOCK symbol on the remote control. The direction indicators light up.

Make sure that all doors and hatches are properly closed before the alarm is activated.

The alarm is not activated if you lock with the key or with the internal door lock.

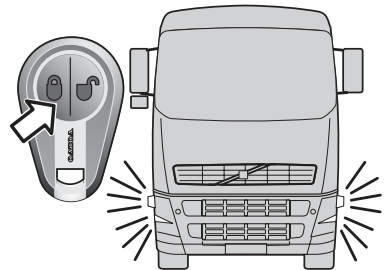

J3017345

# 360 Cab

When the alarm is armed, a diode in the instrument panel's front edge flashes.

The alarm is set off when someone tries to open one of the doors, the hatch to the luggage compartment or the grille. The alarm is also set off if the cab is tipped, if someone moves around in the cab or if the battery is disconnected.

If the alarm is triggered, a siren sounds and the direction indicators begin to flash. The siren will continue to sound and the direction indicators keep flashing for as long as they are being triggered, but not for longer than five minutes.

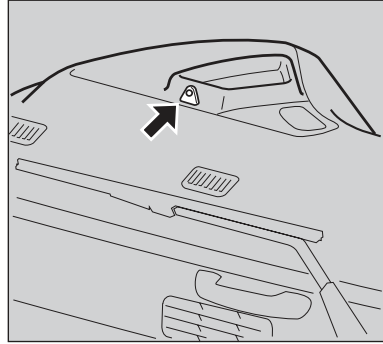

J0011038

## Alarm without motion detectors

The alarm can be activated even if you are still in the cab, if you first of all switch off the motion detectors in the cab.

- 1 Press the switch in the cab
- 2 Check that the lamp in the switch lights
- 3 Press the LOCK symbol on the remote control  
The direction indicators light up

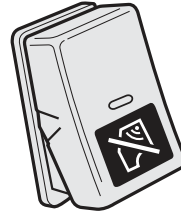

J0011039

- or
- 1 Turn the key to the radio position
  - 2 Press the LOCK symbol on the remote control  
The direction indicators light

If the direction indicators do not light up when the alarm is activated, a door, the hatch to the luggage compartment or the grille might be open. Make sure that all doors and hatches are properly closed before the alarm is activated. If not, the alarm will be set off when the open door or hatch is closed.

The alarm is not activated if you lock with the key or with the internal door lock.

When the alarm is on, a diode in the instrument panel's front edge flashes.

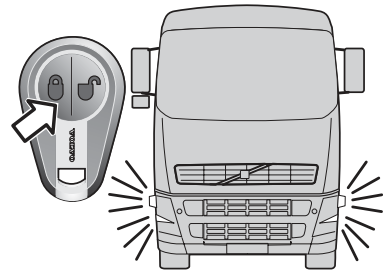

J3017345

The alarm is set off when someone tries to open one of the doors, the hatch to the luggage compartment or the grille.

If the alarm is triggered, a siren sounds and the direction indicators begin to flash. The siren will continue to sound and the direction indicators keep flashing for as long as they are being triggered, but not longer than five minutes.

## Alarm off

Press the UNLOCK symbol on the remote control.  
The diode in the windscreen goes out.

If the direction indicators flash and the diode in the windscreen flashes faster, the alarm has been triggered at some time since the alarm was activated.

If a door or hatch is opened within 2 minutes from deactivation the alarm will be activated again.

The alarm is off when the diode in the windscreen is not lit up.

If the battery in the remote control is discharged, you can turn the alarm off by opening the door with the key. The alarm will then be set off, but will stop when the correct starter key is put in the start lock and the ignition is switched on.

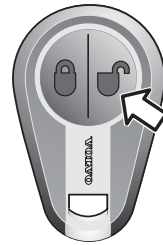

J3017346

## Starting the assault alarm

Hold the switch down for two seconds, The siren sounds

It is possible to lock or unlock the doors and to drive off despite the fact that the assault alarm is activated.

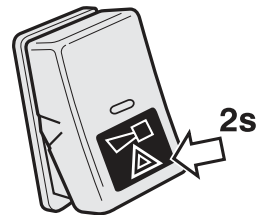

J0011041

## Switching off the assault alarm

Hold the switch down for two seconds. The siren stops.

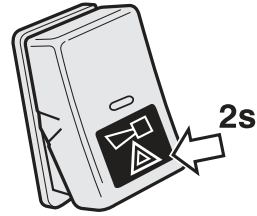

J0011041

## Go into service mode

When the alarm is in service mode, the battery and various parts of the alarm system can be disconnected without the alarm being set off. A symbol on the display shows that the alarm is in service mode.

- 1 Turn the starter key to drive position
- 2 Hold the switch down to switch off the motion detectors
- 3 Press the LOCK symbol on the remote control
- 4 Check that the LED on the instrument panel lights up



J3016334

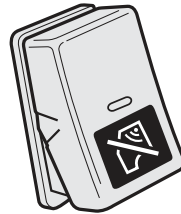

J0011039

The symbol for service mode is shown in the display as long as the starter key is in drive position.



J3017347

## To get out of service mode

- 1 Turn the starter key to drive position
- 2 Hold the switch down to switch off the motion detectors
- 3 Press the UNLOCK symbol on the remote control.
- 4 Check that the LED on the instrument panel goes out

The symbol for service mode in the display goes out.

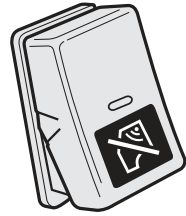

J0011039

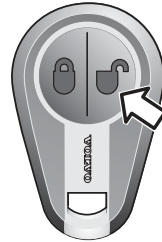

J3017346

### **Note!**

The alarm may be in service mode at delivery.

## Assistance button

An assistance button is located on the instrument panel or radio shelf. The assistance button must be held depressed for at least three seconds for an emergency message to be sent to the office and/or VAS (Volvo Action Service).



J3011613

### **Note!**

The assistance button only functions when the system is switched on.

## Safety instructions

- Under no circumstances interfere with the refrigerant circuit
- The refrigerator box is not intended for storing corrosive material or solvent
- Never cover the air channels or the ventilation openings
- Defrost in good time when you find ice forming in the refrigerator box
- Never use sharp tools to remove ice or to get out objects which have become frozen in
- Never use detergent which contains abrasive agents, acid or solvent
- When the refrigerator box is to be discarded a specialist should be consulted regarding the recycling of the components included in it
- A quick charger may only be connected to the vehicle's battery when the refrigerator box is disconnected

## General

The refrigerator has a refrigerated space for storing drinks and other food which needs cooling. The temperature is adjustable as desired by using the control panel located in the door. The normal setting is five blue LEDs lit, which gives a temperature of about +6°C in the coolbox at normal surrounding temperatures.

## Usage

The refrigerator box is designed to cool foodstuffs. If you wish to use it to cool medicines you must check that they meet the special requirements in force for cooling medical products. All material included in the refrigerator box is approved for contact with food. The refrigerant is freon free.

## Starting the refrigerator

Hold the switched marked "ON/OFF" (1) in for about 1 second. The green LED (2) lights up and the compressor starts. The compressor will only start when the battery voltage exceeds 24.2 Volts. If the battery voltage is lower than this, the green light diode (2) begins to flash.

Adjust the temperature by holding down the temperature selector marked "TEMP" (3). The blue LEDs (4) light one after the other and continue as long as the temperature selector is held in. Select temperature by releasing the temperature selector when the correct number of LEDs light. The greater the number of blue LEDs that are lit, the lower the temperature in the refrigerator. The normal setting is five blue LEDs lit, which gives a temperature of about +6°C in the coolbox at normal surrounding temperatures.

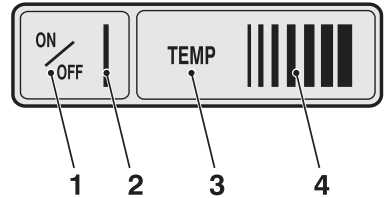

J0010488

## Turning off the refrigerator

Hold the switched marked "ON/OFF" in for about 1 second. The green light diode goes out and the compressor stops. If the refrigerator is not going to be used for a period of time, it should be cleaned thoroughly. After cleaning, the door should be held wide open for at least 24 hours so that all the vapour vanishes and no bad smells occur.

## Voltage protector

To protect the battery from deep discharging, the compressor is automatically turned off if the voltage becomes too low. If the battery voltage is or has been too low, the LED flashes green on the control panel and the compressor does not start. The voltage monitor disconnects at 22.8 V and reconnects again at 24.2 V. If the LED flashes green despite the battery voltage being normal, it is due to the voltage having been too



## 366 Refrigerator

---

low earlier. Start the engine to generate a voltage boost that automatically resets the voltage monitor.

### Tilting the cab

Before the cab is tilted, the refrigerator should be emptied of its contents and switched off.

### Cleaning

Clean the refrigerator with a cloth with lukewarm water and ordinary washing-up liquid. Make sure that it does not force water into the gasket or into the switch. Then dry with a dry cloth. Clean the refrigerator both inside and outside at regular intervals or as soon as it becomes dirty.

### Defrosting

The moisture in the air can cause ice to form on the refrigerator walls, which reduces the refrigerating capacity. Defrost in good time by taking out all food and putting it another refrigerator or freezer compartment so that it keeps cold. Turn off the refrigerator and leave the door open. When the ice melts, most of the water runs out through the draining hole in the rear centre of the refrigerator. Check that the draining hole is not blocked. Then dry up the remaining water thoroughly. Clean with a cloth with lukewarm water and ordinary washing-up liquid, and it is ready for use.

### Interior lighting

The refrigerator has interior lighting which lights up automatically when the door is opened. The lamp is replaced by releasing the entire lighting assembly with a twist to the left. The lamp is type C5W 24V SV 8.5.

## Fault tracing

If the refrigerator does not work, first check that the voltage monitor is not triggered. If the fault persists, contact your Volvo dealer.

## Tips on saving energy

- Let warm goods cool down properly before you put them in the refrigerator
- Defrost as soon as you discover ice formation on the refrigerator walls
- Do not keep the refrigerator at too low a temperature
- Do not open the door except when necessary
- Never leave the door open during normal operation

## Technical specifications

Power requirement	24V/3A
Volume	25 litres
Cooling performance	40°C below ambient temperature (Applies at 32° ambient temperature)
Refrigerant	R134a, 60 g

## Safety instructions

- Under no circumstances interfere with the refrigerant circuit
- The refrigerator box is not intended for storing corrosive material or solvent
- Never cover the air channels or the ventilation openings
- Defrost in good time when you find ice forming in the refrigerator box
- Never use sharp tools to remove ice or to get out objects which have become frozen in
- Never use detergent which contains abrasive agents, acid or solvent
- When the refrigerator box is to be discarded a specialist should be consulted regarding the recycling of the components included in it
- A quick charger may only be connected to the vehicle's battery when the refrigerator box is disconnected

## General

The temperature is adjusted according to your own requirements by using the control panel with digital display which is located to the right of the refrigerator box. Using the plus and minus buttons, temperatures can be selected within the range +2 °C to +12 °C for the refrigerator box.

## Usage

The refrigerator box is designed for storage of cooled food and beverages. If you wish to use it to cool medicines, you must check that it meets the special requirements that apply for cooling medical products. All material included in the refrigerator box is approved for contact with food. The refrigerant is freon-free.

## Starting the refrigerator box

Hold in the switch (2) for about one second. The green LED (3) lights up and the compressor starts. The compressor will only start if the battery voltage is higher than 24.2 V. If the battery voltage is lower, the LED (3) will start to flash red. For further information, see “Voltage monitor”.

Adjust the temperature by holding down the temperature selectors marked “-” (4) or “+” (5). The selected temperature is shown in the digital display (1) and flashes twice before the display shows the current temperature in the refrigerator box. The LED continues to flash green until the selected temperature is reached. Once the selected temperature is reached, the LED lights green continuously. When the temperature rises to a level above the selected temperature, the compressor starts and the LED flashes green as long as the compressor is running.

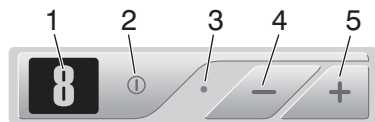

J209124

## Switching off the refrigerator box

Hold in the switch (2) for about 1 second. The green LED goes out and the compressor stops. If the refrigerator box is not going to be used for a period of time, it should be cleaned thoroughly. See “Cleaning”. After cleaning, the cover should be held wide open for at least 24 hours so that all the vapour vanishes and no bad smells occur.

## Voltage protector

To protect the battery from over-discharging, the compressor is automatically turned off if the voltage becomes too low. If the battery voltage is or has been too low, the LED flashes red and the compressor does not start. See also heading “Fault tracing”. The voltage monitor breaks at 22.8 V and restarts again at 24.2 V. If the LED flashes red with a lightning flash despite the battery voltage being normal, this is because the voltage has earlier been too low. Start the engine to

## 370 Fridge

---

generate a voltage boost that automatically resets the voltage monitor.

### Tilting the cab

Before the cab is tilted, the refrigerator box should be emptied of its contents and switched off. Close the refrigerator door before tilting the cab.

### Cleaning

Clean the refrigerator box with a cloth with lukewarm water and ordinary washing-up liquid. Make sure that it does not force water into the packing or into the switch. Then dry with a dry cloth. Clean the refrigerator box both inside and outside at regular intervals or as soon as it becomes dirty.

### Defrosting

Air humidity can cause ice formation that reduces the cooling effect. Defrost in good time by taking out all food and putting it another refrigerator or freezer compartment so that it keeps cold. Turn off the refrigerator and leave the door open. Let the ice melt and then dry up the water thoroughly. Clean with a cloth with lukewarm water and ordinary washing-up liquid, and it is ready for use.

### Fault tracing

If the refrigerator box does not work, first check that the voltage monitor is not triggered. See “Voltage monitor” for actions. If the fault remains, check the fault codes below and contact your Volvo dealer.

If the prism on the outside of the refrigerator box shows green, the unit is operating correctly. If the prism shows red, there is a fault in the refrigerator box and the drawer must then be pulled out so that the fault code on the PCB panel can be checked.

- Faults are indicated by the LED flashing RED a number of times. Each flash will last a ¼ of a second
- After the number of flashes that indicate a fault, there will be a delay with no flashes. The sequence is repeated every fourth second.
- The LED always lights GREEN continuously when the selected temperature has been reached. The LED flashes GREEN while the compressor is running in order to reach the selected temperature.
- If the LED flashes RED with a frequency that is higher than 4 flashes per second and E1 or E2 are displayed, then there is a fault in the NTC-sensor.

E3 Fault codes	
Number of flashes	Type of fault
1	The voltage guard has released
2	The condenser fan circuit is overloaded
3	The compressor does not start
4	Compressor speed is too low
5	The electronic unit's overheating protection has released

## Tips on saving energy

- Let warm goods cool down properly before you put them in the refrigerator box
- Defrost as soon as you discover ice formation in the refrigerator
- Do not keep the refrigerator/freezer space at too low a temperature
- Do not open the door except when necessary
- Never leave the door open during normal operation

# 372 Fridge

---

## Technical specifications

Power requirement	12/24 V / 48 W
Volume, refrigerator	26 litres
Cooling performance	45 °C below the ambient temperature (Applies with an ambient temperature of 32 °C)
Refrigerant	R134a, 37 g

## Start up

1 Turn the key ON-OFF to operate the hand unit.

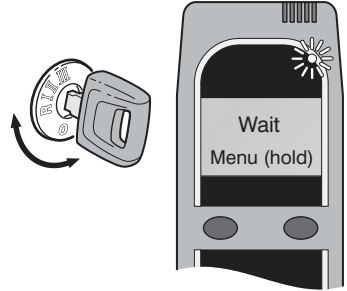

J138920

### Note!

The ignition key should be in the OFF position when the handset is warming up.

2 Wait until the hand unit shows "Blow for 5 seconds".  
The status LED flashes green.

Depending on the ambient temperature, you may need to wait for a few seconds (approx. 15 seconds at 20 °C, approx. 1 minute at 0 °C).

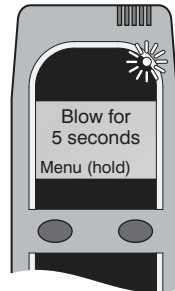

J138921



**3** Fit a nozzle to the hand unit. New users should use a new nozzle.

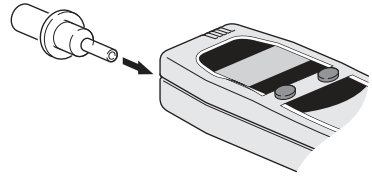

J138922

**4** Blow sufficiently hard into the nozzle. The ALCOLOCK gives a continuous tone to indicate the air flow is sufficient. Continue to blow until you hear a peep and the handset clicks. The LCD display should then show "Wait".

If you blow incorrectly, the LCD screen will show either "Blow less hard" or "Blow longer and harder". Wait until the handset shows "Blow for 5 seconds" before trying again.

Note the test result on the hand unit.

**5A** If "Start engine" is shown in the LCD display and the status lamp shows a green light, then you have managed the test. The measured alcohol level is between 0.00 and 0.10 %.

You have 5 minutes to start the vehicle.

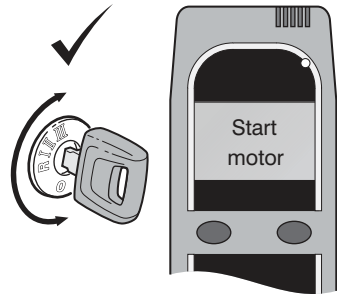

J138923

**5B** If “Warning” is shown in the LCD display and the status lamp lights yellow, you have managed the test but there are traces of alcohol. The measured alcohol level is between 0.11 and 0.19 ‰. You have two alternatives:

- Press the right-hand button to drive despite the risk. You have 5 minutes to start the vehicle.
- Wait for 5 minutes. Carry out a new test.

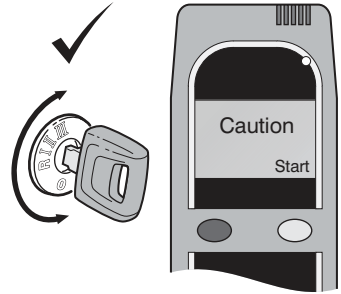

J138924

**5C** If “Lock 0:60” is shown in the display and the status lamp shows a red light, you have exceeded the limit 0.20 ‰. You cannot start the vehicle.

Wait for 60 seconds until the lock timer stops. Carry out a new test.

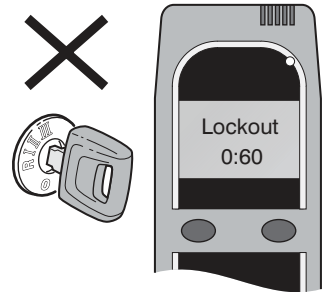

J138925

## Restarting the vehicle

If the motor was turned OFF for less than 30 minutes, you can restart the motor without performing another breath test. This is a safety feature which allows you to quickly restart the motor if it stalls on the road. It is also convenient for making frequent short stops.

Observe the message displayed on the handset

# 376 Alcolock

---

**1A** If “Restart possible” is shown in the display you can restart the vehicle without a new breath test.

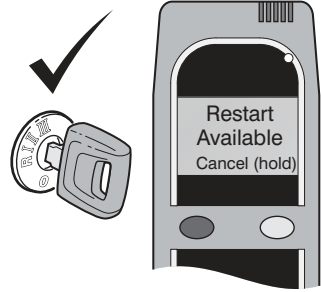

J138926

## Note!

To cancel the restart, press and hold the right button.

**1B** If “Blow for 5 seconds” is shown in the display, the restart period has expired and you must manage a new breath test before you can restart the vehicle.

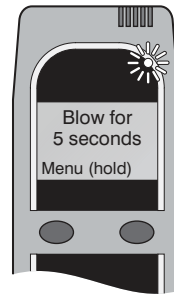

J138921

## Sharing a vehicle

Drivers with their own personal handset can operate the same vehicle without reprogramming the ALCOLOCK. All the custom settings are downloaded into the ALCOLOCK ECU every time a new handset is plugged in.

The handset can be exchanged while the ignition is ON or OFF.

It is strongly recommended you do not exchange the handset while the vehicle is ON. You will be required to conduct a breath test which may distract your attention from the road.

In the interest of your own safety, you should only exchange handsets when the vehicle is parked and the ignition is OFF. To replace the handset while the ignition is OFF, simply unplug the old handset and plug in the new one, as described below.

**1** Squeeze on both sides of the contact on the hand unit's lower part to disconnect the hand unit from the hand unit cable.

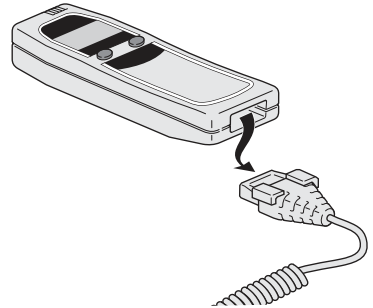

J138928

 **Warning!**

Do not pull the hand unit cable. The contact is similar to a RJ-45-telephone connector and requires you to squeeze lightly on the release tags.

**2** The LCD screen goes out when the cable is released as shown in the figure to the left.

## 378 Alcolock

---

**3** Connect an ALCOLOCK hand unit to the hand unit cable by plugging in the cable to the hand unit's lower part. You should hear a weak click sound.

All personal settings are downloaded to the ALCOLOCK'S CONTROL UNIT.

The ALCOLOCK is now ready for normal operation.

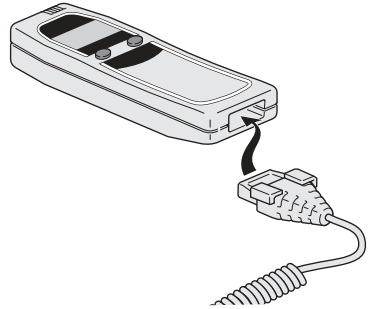

J138929

**The following steps must be taken if the handset was exchanged while the ignition was ON.**

**1** Disconnect the ALCOLOCK'S hand unit cable from the hand unit.

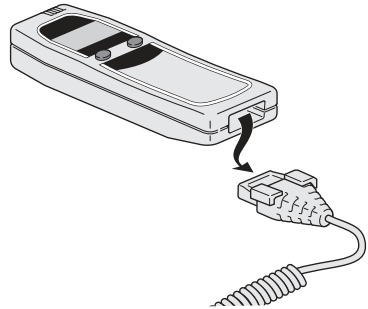

J138928

**2** ALCOLOCK'S CONTROL UNIT peeps twice every 15th second to remind the driver that the hand unit has been disconnected while the engine is running.

**3** Use reasonable power to press in the new hand unit cable into the ALCOLOCK'S hand unit contact. You should hear a weak click sound.

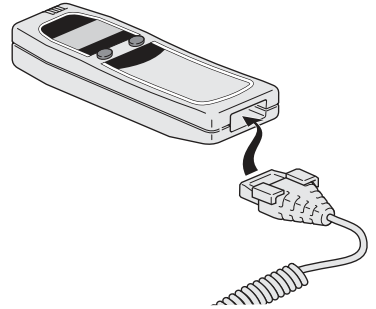

J138929

**4** Depending on the ambient temperature, you may need to wait for a few seconds. During this time “Wait” is shown.

Wait until the hand unit shows “Test again”. The status LED flashes green.



J138930

**5** Fit a new nozzle to the hand unit.

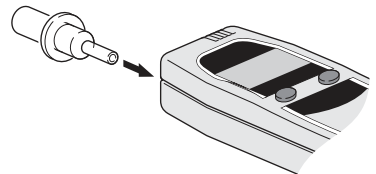

J138922

6 Blow sufficiently hard into the nozzle. Continue to blow until you hear a peep and the handset clicks. The LCD display should then show “Wait”.

If you blow incorrectly, the LCD screen will show either “Blow less hard” or “Blow longer and harder”. Wait until the hand unit shows “Test again”.

Note the message on the handset.

- If “Drive safely” is shown in the LCD display and the status lamp shows a green light, you have managed the test. You can continue to drive the vehicle.
- If “Stop, Switch off engine” is shown in the LCD display and the status lamp flashes red, you have exceeded the permillage limit. You must stop the vehicle safely and switch OFF the engine. Wait until the restart and lock timer stop before you do a new breath test.

## Energy conservation

The ALCOLOCK can be placed into sleep mode after the motor has been turned OFF. In sleep mode, the ALCOLOCK will operate at minimum power to conserve energy in your vehicle battery.

To place the ALCOLOCK into sleep mode, simply press and hold both buttons. Alternatively, you can wait until the sleep timer expires. You can choose from 4 sleep times as described below.

**1** Press and hold the left button to access the user menu.

Step to the Standby position using the left button.

Press the right-hand button to choose the alternative.



J138931

**2** The sub-menu Standby contains 4 pre-programmed standby times: 5, 30, 60 and 90 minutes.

Use the left-hand button to browse

**3** Press and hold down the right-hand button to save and leave the standby menu.

Enter End to return to the normal mode.

## Volume control

Audio tones have been added to the handset to improve the user experience. The volume of these tones can be set inside the user menu.

### **Note!**

The volume setting only applies to the hand unit. These settings do not apply to the ALCOLOCK'S CONTROL UNIT.



## 382 Alcolock

---

**1** Press and hold the left button to access the user menu.

Use the left button to scroll to Volume.

Press the right button to select this option

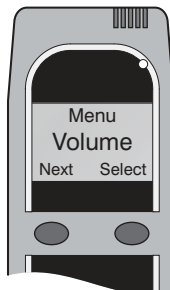

**2** Use the pushbuttons to adjust the volume of the handset.

**3** Press and hold the right button to save and exit the Volume submenu.

Select Exit to return to normal operations.

### **Note!**

Left button decreases the volume.

Right button increases it.

## **Language selection**

The ALCOLOCK can display text messages in several languages. Access the user menu to change the display language.

**1** Press and hold the left button to access the user menu.

Use the left button to scroll to Language.

Press the right button to select this option.



**2** Use the left button to browse through the available languages.

**3** Press and hold the right button to save and exit the Language submenu.

Select Exit to return to normal operations.

## Dates

As with other breath alcohol testers, the ALCOLOCK handset must be calibrated every 12 months to maintain its accuracy. Failure to calibrate the ALCOLOCK within the designated period will disable the breath testing feature.

A service reminder will be displayed on the handset 14 days before the calibration period expires. The calibration expiry date can also be viewed in the user menu as described below.

Additional important dates such as current clock date and time, service date and lockout date can be found in this menu.

**1** Press and hold the left button to access the user menu.

Use the left button to scroll to Dates.

Press the right button to select this option.

**2** Press the left button until the calibration expiry date appears on the LCD.

**3** After you have finished reviewing the date, press and hold the right button to exit the dates submenu.

Select Exit to return to normal operations.

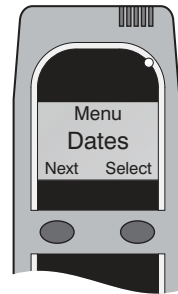

## General messages and errors

### 1 Calibration Expired

After one year of operation the ALCOLOCK will require calibration. Once the calibration period has expired the vehicle can be started without a breath test. Press the right button and turn the key in the normal sequence and the motor will be allowed to start.

### 2 ADR Incompatible

### Note!

Calibrate the handset yearly

Your VOLVO ALCOLOCK is safe to use in ADR—applications. Always make sure that an ADR compatible handset is used.

Newer non ADR compatible ALCOLOCK V3 handsets will temporarily display “ADR incompatible” when they are first connected along with a warning tone. These handsets will operate correctly, but the vehicle will no longer be allowed to transport hazardous goods.

### 3 Other errors

The handset may not accept a breath test for various reasons and messages such as Invalid Sample, Cancelled Try again, communication error, RF (radio frequency) detected, Incorrect or Low voltage. To minimize errors, ensure that the handset is connected properly and cabling, connectors and vehicle battery are in good condition. Turn mobile phones off. Attempt the test again.

### 4 If the ALCOLOCK should brake

If there is any problem to start the truck after a stand still, the ALCOLOCK can be over rided with a 4-digit code. This code is available at Volvo Action Service. The code is changed every day and should not be used for a long time. The truck should be taken to the workshop so the ALCOLOCK can be repaired.

## Technical messages and errors

### 1 Clock Error

The VOLVO ALCOLOCK receives its time signal from the vehicle’s tachograph. Should the tachograph fail or be removed for servicing, a “Clock error” message will be displayed for several seconds. The handset will operate correctly, but dates will not be correctly displayed until a properly functioning tachograph is connected.

### 2 Technical Error

Should the handset detect an internal power failure “Technical error” will be displayed.

In this state, the motor can be started by pressing the right button and turning the key in the normal sequence. No breath test is required when a technical error is detected.

### **3 Error codes**

The handset will display error code 10, 20, 30, 40, 45 or 50 if a technical fault is detected. The handset will reset to allow the user to attempt another breath test. If the condition persists the ALCOLOCK will require servicing.

## Safe Operation of the Radio

The driving conditions today require that the driver pays full attention to the road at all times. It is advised that when using this radio while driving the driver maintain full concentration on the road. Therefore it is strongly advised to do the following:

- Never Change a CD or read CD labels while driving.
- Always Ensure the Volume of the Audio System is set so that outside acoustics can also be heard.
- Use when possible the Steering wheel controls. It is a feature to make it both easy and safe to handle the radio while driving.

## Introduction

The following instructions explain the general functions and operations of the Volvo Radio.

Radio information is displayed through the LCD display on the radio.

The radio is commanded by:

- The Faceplate.
- By the Remote Control.
- By the Steering Wheel Controls.

The main functions of the audio unit are:

- Radio Mode.
- CD

The main functions of the audio unit are:

- Radio Mode.
- CD (supporting MP3 and WMA).
- USB (supporting MP3 and WMA).
- iPod.
- Auxiliary audio input.

- Hands free (Bluetooth Phone Operation).

## General Overview

### Radio/CD Controls Quick Reference Guide

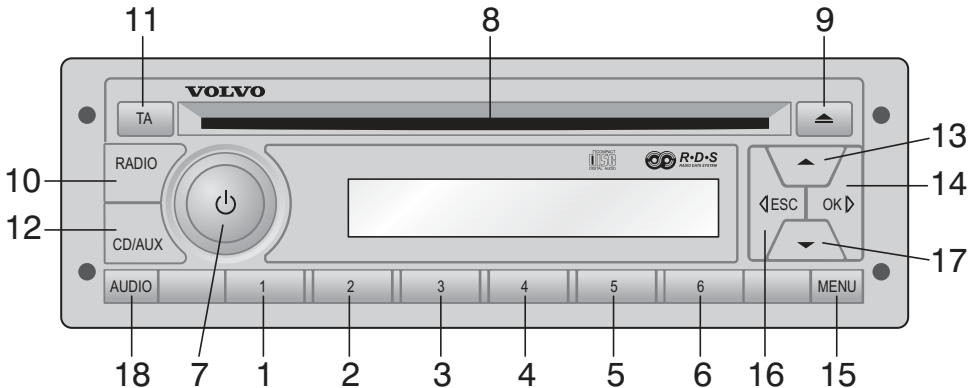

J171284

- 1 “Preset 1” Button**  
**Radio:** Push and release: Recall Preset Station  
**Radio:** Push and hold: Store Preset Station
- 2 “Preset 2” Button**  
**Radio:** Push and release: Recall Preset Station  
**Radio:** Push and hold: Store Preset Station
- 3 “Preset 3” Button**  
**Radio:** Push and release: Recall Preset Station  
**Radio:** Push and hold: Store Preset Station
- 4 “Preset 4” Button**  
**Radio:** Push and release: Recall Preset Station  
**Radio:** Push and hold: Store Preset Station
- 5 “Preset 5” Button**  
**Radio:** Push and release: Recall Preset Station  
**Radio:** Push and hold: Store Preset Station
- 6 “Preset 6” Button**  
**Radio:** Push and release: Recall Preset Station

- Radio:** Push and hold: Store Preset Station
- 7 **“Rotary Knob/PWR” Button**
  - Push:** Power On and Off
  - Turn:** Volume Adjust & Audio Value Update
- 8 **CD Slot**
  - CD:** Insert / Remove CD
- 9 **“Eject CD” Button**
  - CD:** Eject CD
- 10 **Radio Select Mode**
  - Radio:** Choose from FM & AM Bands
- 11 **Information (Traffic / News)**
  - Radio:** Switch Traffic on or off
  - Radio:** Cancel ongoing Traffic or News message
- 12 **CD/ Mode Select**
  - CD:** Switch to CD
- 13 **Up Button**
  - Radio:** Manual tuning up
- 14 **(Fast) Forward >> Button**
  - Radio:** Seek
  - CD:** Push and release: Select Next Track
  - CD:** Push and hold: Fast Forward
- 15 **Menu Button**
  - Radio:** Push and release: Menu Access
- 16 **(Fast) Reverse << Button**
  - Radio:** Seek
  - CD:** Push and release: Select previous Track
  - CD:** Push and hold: Fast Reverse
- 17 **Down Button**
  - Radio:** Manual tuning down
- 18 **Audio Button**
  - General:** Audio Settings

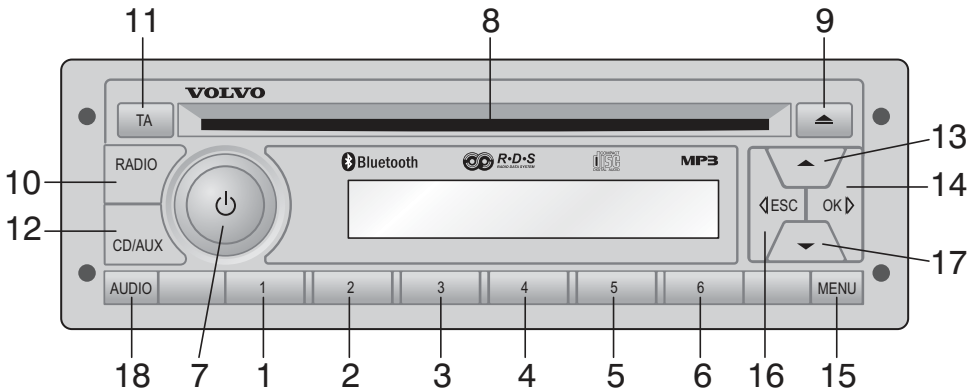

J170065

- 1 **“Preset 1” Button**  
**Radio:** Push and release: Recall Preset Station  
**Radio:** Push and hold: Store Preset Station
- 2 **“Preset 2” Button**  
**Radio:** Push and release: Recall Preset Station  
**Radio:** Push and hold: Store Preset Station
- 3 **“Preset 3” Button**  
**Radio:** Push and release: Recall Preset Station  
**Radio:** Push and hold: Store Preset Station
- 4 **“Preset 4” Button**  
**Radio:** Push and release: Recall Preset Station  
**Radio:** Push and hold: Store Preset Station
- 5 **“Preset 5” Button**  
**Radio:** Push and release: Recall Preset Station  
**Radio:** Push and hold: Store Preset Station
- 6 **“Preset 6” Button**  
**Radio:** Push and release: Recall Preset Station  
**Radio:** Push and hold: Store Preset Station
- 7 **“Rotary Knob/PWR” Button**  
**Push:** Power On and Off  
**Turn:** Volume Adjust & Audio Value Update
- 8 **CD Slot**  
**CD:** Insert / Remove CD
- 9 **“Eject CD” Button**



**CD:** Eject CD

10 **Radio Select Mode**

**Radio:** Choose from FM & AM Bands

11 **Information (Traffic / News)**

**Radio:** Switch Traffic on or off

**Radio:** Cancel ongoing Traffic or News message

12 **CD/Aux Mode Select**

**CD/USB:** Switch between sources other than radio

13 **Up Button**

**Radio:** Manual tuning up

14 **(Fast) Forward >> Button**

**Radio:** Seek CD/USB: Push and release: Select Next Track

**CD/USB:** Push and hold: Fast Forward

**Bluetooth Phone:** Accept incoming call

15 **Menu Button**

**Radio:** Push and release: Menu Access

16 **(Fast) Reverse << Button**

**Radio:** Seek

**CD/USB:** Push and release: Select previous Track

**CD/USB:** Push and hold: Fast Reverse

**Bluetooth Phone:** Reject incoming call or hang up

**iPod:** Push and hold: Enter iPod menu

17 **Down Button**

**Radio:** Manual tuning down

18 **Audio Button**

**General:** Audio Settings

## Steering Wheel Controls Quick Reference Guide

- 1 **“Next” Button**  
**Radio:** Push and release: Seek  
**Radio:** Push and hold: Manual tune up  
**CD/USB:** Push and release: Select next track  
**CD/USB:** Push and hold: Fast forward
- 2 **“Previous” Button**  
**Radio:** Push and release: Seek  
**Radio:** Push and hold: Manual tune down  
**CD/USB:** Push and release: Select previous track  
**CD/USB:** Push and hold: Fast reverse
- 3 **“YES” Button**  
**Bluetooth phone:** Accept incoming call
- 4 **“NO” Button**  
**Bluetooth phone:** Reject incoming call or hang up
- 5 **“Vol +” Button**  
**General:** Increase Sound Volume
- 6 **“Vol —” Button**  
**General:** Decrease Sound Volume

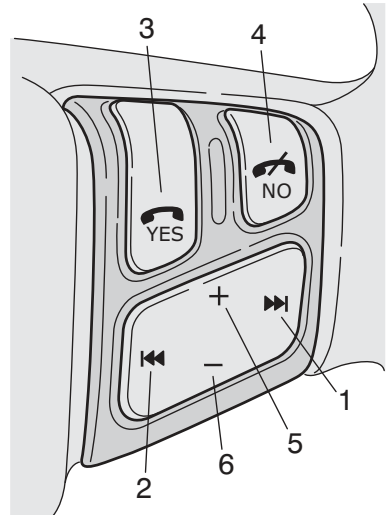

J170066

## Remote Control Quick Reference Guide

- 1 **“Band” Button**  
**Radio:** Select between FM & AM Bands
- 2 **“PWR” Button**  
**General:** Turns the Radio On and Off
- 3 **“Seek” Button**  
**Radio:** Seek  
**CD/USB:** Next or previous track
- 4 **“Mute / Pause” Button**  
**General:** Mute or Pause the source of audio
- 5 **“Aux” Button**  
**Source:** Select between USB, iPod or AUX
- 6 **“CD Select” Button**  
**CD:** Select CD
- 7 **Volume buttons**  
**Radio/CD:** Adjust the volume up and down
- 8 **Preset 1 to 6**  
**Radio:** Select a Preset Station

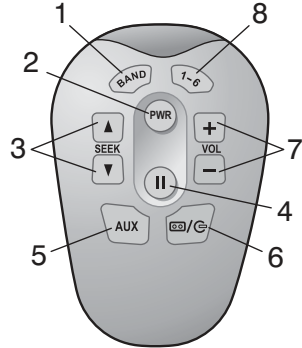

J170068

## Display Quick Reference Guide

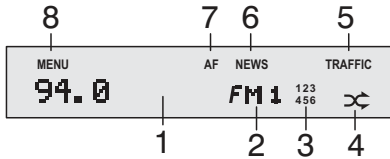

J192785

- 1 **Text Display**  
**Radio:** Displays radio frequency and station name  
**CD:** Displays track, time and music when available
- 2 **Source display**  
**Radio:** Displays radio band (FM1, FM2, FM3 or AM)  
**CD:** Displays CD
- 3 **Preset Number**  
**Radio:** Displays Preset Number
- 4 **Random**  
**CD:** Displayed when random is on
- 5 **Traffic Info**  
**General:** Indicates that the Traffic function is on
- 6 **News Info**  
**General:** Indicates that the News function is on
- 7 **AF**  
**General:** Indicates that the AF (Alternative frequency) function is on
- 8 **Menu**  
**General:** Displayed when in Menu

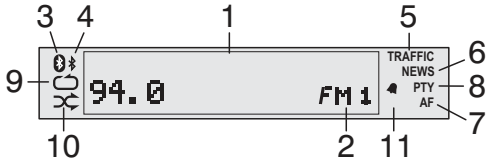

J170070

- 1 **Text Display**  
**Radio:** Displays radio frequency and station name  
**CD/USB:** Displays track, time and music when available
- 2 **Source display**  
**Radio:** Displays radio band (FM1, FM2, FM3 or AM)  
**CD/USB:** Displays other source than radio
- 3 **Phone connected**  
**General:** Indicates that the phone is connected
- 4 **Bluetooth on**  
**General:** Indicates that the Bluetooth function is on
- 5 **Traffic Info**  
**General:** Indicates that the Traffic function is on
- 6 **News Info**  
**General:** Indicates that the News function is on
- 7 **AF**  
**General:** Indicates that the AF (Alternative frequency) function is on
- 8 **PTY**  
**General:** Indicates that the PTY (Program type) function is on
- 9 **Repeat**  
**CD/USB:** Display when Repeat is on
- 10 **Random**  
**CD/USB:** Display when Random is on
- 11 **Alarm**

**CD/USB:** Indicates that the Alarm clock function is on

## Main Functions

Many functions are controlled or adjusted through the radio Menu. If the Menu screen is open and the radio experiences no activity for a 10 second period, the radio will cancel any incomplete actions, close the Menu screen and return to normal operation. The radio will save all completed changes.

## Power

### Switching On & Off, Mute and Pause of the Audio System

The audio system is switched on or off by pressing the “Rotary Knob/PWR” Button. If the driver wants to quickly mute the audio system sound, press the “Rotary Knob/PWR” Button.

## Radio Mode

### Band Selection (FM and AM)

To select the radio as the play mode, turn the radio on and press the “RADIO” button . The radio will then be active on the last used radio band (AM, FM etc.).

To switch between the bands (AM/FM1/FM2/FM3) use the “RADIO” button .

### Seek in radio mode

There are two ways to seek for a radio station:

- 1 Use the Seek buttons to seek up or down on the radio. Once a station is found the seek function will stop. OR
- 2 Use the Seek buttons of the Steering Wheel Control to seek up or down on the radio. Once a station is found the seek function will stop. (Optional feature)

## Manuel tuning

Manual Tuning can be performed in two ways:

- 1 Push Up button or Down button to tune up or down respectively. OR
- 2 Push and hold the Seek buttons of the Steering Wheel Control, to tune up or down respectively. (Optional feature)

## Presets (Storing Radio Stations)

Up to 12 FM and 6 AM radio stations can be stored for fast access. There are three sets of FM radio preset bands, which are FM1, FM2, FM3 and one AM radio preset band. Each preset band can store 6 stations on buttons 1 to 6. To store a specific station into a preset button, do the following:

- 1 Push the “RADIO” button until the required frequency band is active (AM, FM1, FM2, FM3)
- 2 Tune the radio to the desired station.
- 3 Push and hold the desired preset button (1–6).
- 4 There will be a short delay as the station is stored. When audio returns the process is completed.

## Presets (Selecting a Stored Radio Station)

To select one of the preset stations, perform the following:

- 1 Push “RADIO” button to select the required band (AM, FM1, FM2, FM3).
- 2 Push and release the required preset button (1–6) to activate the desired station.

## Scan mode

The scan feature allows the user to perform a radio station search without having to toggle manually to the stations. When in scan mode, each station found will play for 10 seconds to give the user a chance to sample the station program or music. The scan will then

continue on to the next available station unless the user chooses to stop the scan and stay at the present station.

To enter scan mode, perform the following:

- 1 Press “MENU” button on the radio.
- 2 Select “SCAN” by pressing “OK”.

To exit scan mode and stay at the present station perform:

- 1 Press the “RADIO” button.

### **Radio Data System (RDS)**

RDS is used by many radio stations throughout Europe. The system provides features such as Automatic frequency changing (AF) and trigger signals for Traffic announcements (TA) and News.

### **Alternative Frequency (AF)**

The range for FM stations is quite limited. For this reason many stations transmit on alternative frequencies in different areas. By using the AF function, the driver can listen to such a station continuously without retuning the radio manually between the areas.

Some stations transmit different programs in different areas during some part of the day. To avoid tuning away from a locally sent program, the AF function can be set to stay with that program by using AF LOC (local).

When travelling long distances the reception of a locally sent program may be lost. In such case, using the AF REG (regional) will allow the radio to tune to other transmitters within that station.

When a radio search is performed the first time after activating AF, the radio creates an internal list of available stations. An additional search will be done due to that list, which makes the search faster. The list is sorted with respect to the stations’ RDS codes and the stations may not be tuned in frequency order in an AF search.



## AF Activation

To activate or deactivate AF, perform the following:

- 1 Push the “MENU” button.
- 2 Push Up button or Down button until “AF” is displayed.
- 3 Select the AF status by pressing the “OK” button.

When AF is active, the display shows the AF icon.

## Traffic Announcement (TA) and News

This feature allows the radio to play traffic or news announcements even if the radio is in CD mode. To ensure that the message is heard, the volume will be automatically adjusted to the highest of the three following volume levels:

- Volume level 10.
- The present normal volume level.
- A retained TA/News volume level.

The TA/News volume is set by adjusting the volume during a TA/News announcement. The radio will retain this TA/News volume setting.

## Traffic Activation

There are two ways to activate the Traffic function:

- 1 Push and release the information TA button.

OR

- 1 Press the “MENU” button on the radio.
- 2 Push Up button or Down button until “TRAFFIC” is displayed.
- 3 Activate “TRAFFIC” by pressing “OK” button.

When Traffic is active, the display shows the Traffic icon.

## Note!

If Traffic is active, then the AF function will be active.

## News Activation

To activate the News function, perform the following:

- 1 Press the “MENU” button on the radio.
- 2 Push Up button or Down button until “NEWS” is displayed.
- 3 Activate “NEWS” by pressing “OK” button.

When News is active, the display shows the News icon.

### **Note!**

If News is active, then the AF function will be active.

## Traffic / News Announcement Rejection

To reject a current Traffic or News announcement, Push and release the information TA button.

## Enhanced Information Concerning Other Networks (EON)

A network of stations may transmit News or Traffic announcements on just one of its stations. The RDS feature EON ensures that this information is received by doing an automatic frequency change. After the announcement the radio will return to the previous station.

### **Note!**

The Traffic and/or News functions need to be active for this feature to work.

## Emergency Announcement - Alarm

In the event of a major disaster, an emergency announcement may be transmitted on the radio. When such is received, "ALARM" is displayed and the Volume is adjusted as for TA/News announcements.

## CD Mode

The radio is designed to work with standard CD format on CD-R as well as CD-RW discs.

## Switching to CD Mode

There are two ways to switch to the CD mode:

- 1 Push the “CD” button until CD shows on display.  
OR
- 2 Insert a CD into the CD slot.

## **Eject a CD**

To eject a CD press the Eject button. When CD is ejected the radio will play the previous audio source. If the CD is not removed from the CD slot, it will automatically reload after 15 seconds.

## **Changing a Track on a CD**

There are two ways to change a track on a CD:

- 1 Push and release the “OK” button or the “ESC” button on the radio to move to the next or previous track respectively. OR
- 2 Using the steering wheel controls: Push and release Seek buttons to move to the previous or next track respectively. (Optional feature)

## **Fast Forward or Fast Reverse on a CD**

Fast forwarding or reversing a CD can be performed in one of two ways:

- 1 Push and hold the “OK” button or the “ESC” button on the radio to fast forward or fast reverse respectively. OR
- 2 Using the steering wheel controls: Push and release Seek buttons to move to fast reverse or fast forward respectively. (Optional feature)

## **Playing Tracks on a CD or in Random Order**

There are two possible Random settings for a CD: Random All and Random Folder (If the content of the CD is stored in folders). To play tracks in random order, do the following:

- 1 Press the “MENU” button
- 2 Push Up button or Down button until “RANDOM” is displayed.
- 3 Activate Random by pressing the “OK” button.

## Scan a CD

When CD is scanned, the first 10 seconds of each track is played. To activate Scan, do the following:

- 1 Press the “MENU” button.
- 2 Select “SCAN” by pressing “OK” button.

Scanning will stop if

- 1 The “ESC” or “OK” button is pressed. OR
- 2 All tracks are browsed through.

## Audio Settings

### Adjusting Volume Up and Down

The audio systems volume can be adjusted up by turning the Rotary knob in a clockwise direction and adjusted down by turning the knob in a counter-clockwise direction.

It can also be adjusted up and down by using the + and — on the steering wheel controls respectively.

### Adjusting Bass Up and Down

The audio systems bass can be adjusted by pressing the “AUDIO” button until “BASS” shows on the display. The bass is then adjusted up by turning the Rotary knob in a clockwise direction and adjusted down by turning the knob in a counter-clockwise direction. It can also be adjusted up and down by using the “OK” button or the “ESC” button on the radio respectively.

### Adjusting Treble Up and Down

The audio systems treble can be adjusted by pressing the “AUDIO” button until “TREBLE” shows on the display. The treble is then adjusted up by turning the Rotary knob in a clockwise direction and adjusted down by turning the Rotary knob in a counter-clockwise direction. It can also be adjusted up and down by using the “OK” button or the “ESC” button on the radio respectively.

## Adjusting Balance Left and Right

The audio systems balance can be adjusted by pressing the “AUDIO” button until “BALANCE” shows on the display. The balance is then adjusted right by turning the Rotary knob in a clockwise direction and adjusted left by turning the Rotary knob in a counter-clockwise direction. It can also be adjusted right and left by using the “OK” button or the “ESC” button on the radio respectively.

## Adjusting Fader Front and Back

The audio systems fader can be adjusted by pressing the “AUDIO” button until “FADER” shows on the display. The fader is then adjusted front by turning the Rotary knob in a clockwise direction and adjusted back by turning the Rotary knob in a counter-clockwise direction. It can also be adjusted front and back by using the “OK” button or the “ESC” button on the radio respectively.

## Speakers Selection

(Optional feature)

The audio system can be adjusted to 4 or 2 speaker mode by performing the following:

- 1 Press the “MENU” button.
- 2 Push Up button or Down button until “ADVANCE” is displayed.
- 3 Press the “OK” button to enter the Advance submenu.
- 4 Push Up button or Down button until “SPEAKERS” is displayed.
- 5 Change between 2CH and 4CH by pressing the “OK” button.

## Clock

### Displaying the Time

By default, the time of day is displayed only when the ignition is ON and the radio is OFF. The Clock can be

set to show the time also when radio is ON, by doing the following:

- 1 Push the “MENU” button.
- 2 Push Up button or Down button until “CLOCK” is displayed.
- 3 Push the “OK” button to enter Clock sub menu.
- 4 Push Up button or Down button until “VISIBLE” is displayed.
- 5 Push the “OK” button to change between ON/OFF status.

### **12- or 24-Hour Format**

The clock can be set to 12-hour or 24-hour mode. The 12-hour mode distinguishes between AM and PM. To change the time format, do the following:

- 1 Push the “MENU” button.
- 2 Push Up button or Down button until “CLOCK” is displayed.
- 3 Push the “OK” button to enter Clock sub menu.
- 4 Push Up button or Down button until “12/24 HR” is displayed.
- 5 Push the “OK” button to change between 12H or 24H options.

### **Setting the Clock**

To set the clock manually, do the following:

- 1 Push the “MENU” button.
- 2 Push Up button or Down button until “CLOCK” is displayed.
- 3 Push the “OK” button to enter Clock sub menu.
- 4 Push Up button or Down button until “SET TIME” is displayed.
- 5 Push the “OK” button to enter the Set time sub menu.
- 6 Push Up button or Down button to adjust the hours up or down respectively.

### **Note!**

Normally the time is set automatically by the trucks system. The option to manually set the time will then not be available.

- 7 Push the “OK” button to set the hour and toggle to the minute adjustment.
- 8 Push Up button or Down button to adjust the minutes up or down respectively.
- 9 Push the “OK” button to save the time and finish the process.

## Anti Theft Code (Guard)

The radio unit is set to function with only one vehicle. The Guard feature prohibits operation of the radio anywhere else. The Guard is automatic and no manual handling is normally needed.

### In case of malfunction

If, by some reason, the radio fails in detecting the required vehicle, the user will be prompted to enter the Anti Theft Code (sticker found in Drivers Handbook). The display will then show "CODE 0000". Please note that this is a malfunction and should be checked at an authorized workshop. To enter the code, do the following:

- 1 For the current (blinking) digit, turn the volume knob until the right number is shown.
- 2 Press the power button to enter the digit. The next digit will start to blink.
- 3 Repeat step 1 and 2 until all four digits has been entered.

The user has three tries to enter the code. If these are unsuccessful the radio will be locked for 60 minutes until three new tries are allowed.

### Deactivating Guard

It is possible to deactivate Guard, but (is) not recommended. To deactivate the Guard function, do the following:

- 1 Push the “MENU” button.
- 2 Push Up button or Down button until “ADVANCE” is displayed.

- 3 Push the “OK” button to enter Advance sub menu.
- 4 Push Up button or Down button until “GUARD” is displayed.
- 5 Push the “OK” button to enter.
- 6 Push the “OK” button to set Guard ON or OFF.

The user will be requested for the Anti Theft Code to deactivate or activate Guard. The display will then show "CODE 0000" with the first digit blinking. To enter the code, do the following:

- 1 For the current (blinking) digit, turn the volume knob until the right number is shown.
- 2 Press the power button to enter the digit. The next digit will start to blink.
- 3 Repeat step 1 and 2 until all four digits has been entered.

The user has three tries to enter the code. If these are unsuccessful the radio will be locked for 60 minutes until three new tries are allowed.

## **Tips and Tricks**

### **CD, MP3, and WMA**

- A CD with MP3 or WMA will take several seconds to read before it starts playing.
- For best performance, a MP3/WMA CD should not contain other file types than MP3, WMA, M3U and PLS.

## **Main Functions**

Many functions are controlled or adjusted through the radio Menu. If the Menu screen is open and the radio experiences no activity for a 10 second period, the radio will cancel any incomplete actions, close the Menu screen and return to normal operation. The radio will save all completed changes.



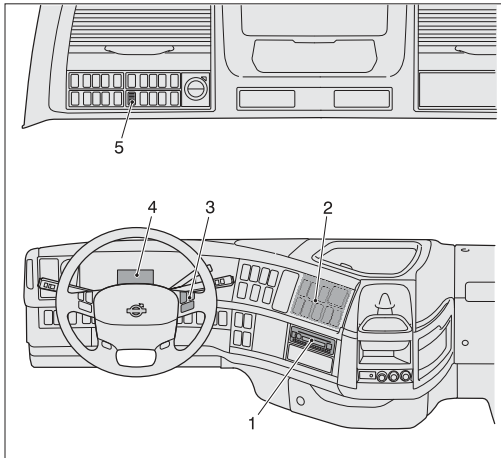

- 1 Radio
- 2 USB port
- 3 Steering wheel controls
- 4 Driver Information Display
- 5 Microphone

## Power

### Switching On & Off, Mute and Pause of the Audio System

The audio system is switched on or off by pressing the “Rotary Knob/PWR” Button. If the driver wants to quickly mute the audio system sound, press the “Rotary Knob/PWR” Button.

## Radio Mode

### Band Selection (FM and AM)

To select the radio as the play mode, turn the radio on and press the “RADIO” button . The radio will then be active on the last used radio band (AM, FM etc.).

To switch between the bands (AM/FM1/FM2/FM3) use the “RADIO” button .

## Seek in radio mode

There are two ways to seek for a radio station:

- 1 Use the Seek buttons to seek up or down on the radio. Once a station is found the seek function will stop. OR
- 2 Use the Seek buttons of the Steering Wheel Control to seek up or down on the radio. Once a station is found the seek function will stop.

## Manuel tuning

Manual Tuning can be performed in two ways:

- 1 Push Up button or Down button to tune up or down respectively. OR
- 2 Push and hold the Seek buttons of the Steering Wheel Control, to tune up or down respectively.

## Presets (Storing Radio Stations)

Up to 12 FM and 6 AM radio stations can be stored for fast access. There are three sets of FM radio preset bands, which are FM1, FM2, FM3 and one AM radio preset band. Each preset band can store 6 stations on buttons 1 to 6. To store a specific station into a preset button, do the following:

- 1 Push the “RADIO” button until the required frequency band is active (AM, FM1, FM2, FM3)
- 2 Tune the radio to the desired station.
- 3 Push and hold the desired preset button (1–6).
- 4 There will be a short delay as the station is stored. When audio returns the process is completed.

## Presets (Selecting a Stored Radio Station)

To select one of the preset stations, perform the following:

- 1 Push “RADIO” button to select the required band (AM, FM1, FM2, FM3).

- 2 Push and release the required preset button (1–6) to activate the desired station.

## Scan mode

The scan feature allows the user to perform a radio station search without having to toggle manually to the stations. When in scan mode, each station found will play for 10 seconds to give the user a chance to sample the station program or music. The scan will then continue on to the next available station unless the user chooses to stop the scan and stay at the present station. To enter scan mode, perform the following:

- 1 Press “MENU” button on the radio.
- 2 Select “SCAN” by pressing “OK”.

To exit scan mode and stay at the present station perform:

- 1 Press the “RADIO” button. OR
- 2 Press the Previous button or the Next button on the steering wheel.

## Radio Data System (RDS)

RDS is used by many radio stations throughout Europe. The system provides features such as Automatic frequency changing (AF) and trigger signals for Traffic announcements (TA) and News.

## Alternative Frequency (AF)

The range for FM stations is quite limited. For this reason many stations transmit on alternative frequencies in different areas. By using the AF function, the driver can listen to such a station continuously without retuning the radio manually between the areas.

Some stations transmit different programs in different areas during some part of the day. To avoid tuning away from a locally sent program, the AF function can be set to stay with that program by using AF LOC (local).

When travelling long distances the reception of a locally sent program may be lost. In such case, using the AF REG (regional) will allow the radio to tune to other transmitters within that station.

When a radio search is performed the first time after activating AF, the radio creates an internal list of available stations. An additional search will be done due to that list, which makes the search faster. The list is sorted with respect to the stations' RDS codes and the stations may not be tuned in frequency order in an AF search.

## **AF Activation**

To activate or deactivate AF, perform the following:

- 1 Push the "MENU" button.
- 2 Push Up button or Down button until "AF" is displayed.
- 3 Select the AF status by pressing the "OK" button.

When AF is active, the display shows the AF icon.

## **Traffic Announcement (TA) and News**

This feature allows the radio to play traffic or news announcements even if the radio is in CD mode. To ensure that the message is heard, the volume will be automatically adjusted to the highest of the three following volume levels:

- Volume level 10.
- The present normal volume level.
- A retained TA/News volume level.

The TA/News volume is set by adjusting the volume during a TA/News announcement. The radio will retain this TA/News volume setting.

## **Traffic Activation**

There are two ways to activate the Traffic function:

- 1 Push and release the information TA button.

OR

### **Note!**

If Traffic is active, then the AF function will be active.

# 410 Radio/CD

---

- 1 Press the “MENU” button on the radio.
- 2 Push Up button or Down button until “TRAFFIC” is displayed.
- 3 Activate “TRAFFIC” by pressing “OK” button.

When Traffic is active, the display shows the Traffic icon.

## News Activation

To activate the News function, perform the following:

- 1 Press the “MENU” button on the radio.
- 2 Push Up button or Down button until “NEWS” is displayed.
- 3 Activate “NEWS” by pressing “OK” button.

When News is active, the display shows the News icon.

## Note!

If News is active, then the AF function will be active.

## Traffic / News Announcement Rejection

To reject a current Traffic or News announcement, Push and release the information TA button.

## Enhanced Information Concerning Other Networks (EON)

A network of stations may transmit News or Traffic announcements on just one of its stations. The RDS feature EON ensures that this information is received by doing an automatic frequency change. After the announcement the radio will return to the previous station.

## Note!

The Traffic and/or News functions need to be active for this feature to work.

## Emergency Announcement - Alarm

In the event of a major disaster, an emergency announcement may be transmitted on the radio. When such is received, "ALARM" is displayed and the Volume is adjusted as for TA/News announcements.

## Program type (PTY)

Some stations transmit common program types, e.g. Sports, Drama and Finance, along with an identifying

signal. This allows the user to search for such programs.

## **PTY Activation / Deactivation**

To activate the PTY function, perform the following:

- 1 Press the “MENU” button on the radio.
- 2 Push Up button or Down button until “PTY” sub menu and activate/deactivate by pushing the “OK” button.
- 3 Activate “PTY” by pressing “OK” button.

When PTY is active, the display shows the PTY icon. When a search is performed, this is indicated by displaying the chosen Program type.

## **CD Mode**

The radio is designed to work with standard CD format and MP3 and WMA files. The CD player will accept CD-R as well as CD-RW discs.

## **Switching to CD Mode**

There are two ways to switch to the CD mode:

- 1 Push the “CD” button until CD shows on display.  
OR
- 2 Insert a CD into the CD slot.

## **Eject a CD**

To eject a CD press the Eject button. When CD is ejected the radio will play the previous audio source. If the CD is not removed from the CD slot, it will automatically reload after 15 seconds.

## **Changing a Track on a CD**

There are two ways to change a track on a CD:

- 1 Push and release the “OK” button or the “ESC” button on the radio to move to the next or previous track respectively. OR

- 2 Using the steering wheel controls: Push and release Seek buttons to move to the previous or next track respectively.

## **Fast Forward or Fast Reverse on a CD**

Fast forwarding or reversing a CD can be performed in one of two ways:

- 1 Push and hold the “OK” button or the “ESC” button on the radio to fast forward or fast reverse respectively. OR
- 2 Using the steering wheel controls: Push and release Seek buttons to move to fast reverse or fast forward respectively.

## **Playing Tracks on a CD or in Random Order**

There are two possible Random settings for a CD: Random All and Random Folder (If the content of the CD is stored in folders). To play tracks in random order, do the following:

- 1 Press the “MENU” button
- 2 Push Up button or Down button until “RANDOM” is displayed.
- 3 Activate Random by pressing the “OK” button.
- 4 Push Up button or Down button to choose between All and Folder.
- 5 Push “OK” button to activate the desired Random mode.

## **Repeating Tracks on a CD**

There are three possible Repeat settings for a CD: Repeat All, Repeat track and Repeat Folder (If the content of the CD is stored in folders). By default, Repeat All is active.

To change the repeat setting, do the following:

- 1 Press the “MENU” button
- 2 Push Up button or Down button until “REPEAT” is displayed.

- 3 Enter Repeat Sub menu by pressing “OK” button.
- 4 Push Up button or Down button to choose between All, Track and Folder.
- 5 Push “OK” button to activate the desired Repeat mode.

## Changing to another Folder on a CD

If the content of the CD is stored in folders, it is possible to change folders directly. To do this, push either the Up button or the Down button to move to the next or previous album/folder respectively.

## Scan a CD

When CD is scanned, the first 10 seconds of each track is played. To activate Scan, do the following:

- 1 Press the “MENU” button.
- 2 Select “SCAN” by pressing “OK” button.

Scanning will stop if

- 1 The “ESC” or “OK” button is pressed. OR
- 2 All tracks are browsed through.

## External audio input

There are three possible external audio input modes, USB, iPod and Aux. A USB and an AUX device can be connected and accessible at the same time.

However, if an iPod is connected the USB and the AUX devices will be disabled as an available source.

## USB Mode

The radio is designed to work with USB devices formatted with the USB Mass Storage Device Class standard. Other USB devices may still work with the radio though. If a USB device doesn't work properly, try reconnecting the device which may solve the problem in some cases.

A USB device must be connected prior to operating in this mode.



## Switching to USB Mode

There are two ways to switch to USB mode.

- 1 Push the CD/AUX button until USB shows on the display. Or
- 2 Connect a USB device.

## Disconnecting a USB device

No special preparations are needed to disconnect the USB device. When USB device is removed the radio will play the previous audio source.

## Changing a Track on a USB Device

There are two ways to change a track on a USB:

- 1 Push and release the “OK” button or the “ESC” button on the radio to move to the next or previous track respectively. OR
- 2 Using the steering wheel controls: Push and release Seek buttons to move to the previous or next track respectively.

## Fast Reverse or Fast Forward on a USB Device

Fast forwarding or reversing can be performed in one of two ways:

- 1 Push and hold the “OK” button or the “ESC” button on the radio to fast forward or fast reverse respectively. OR
- 2 Using the steering wheel controls: Push and hold Seek buttons to move to fast reverse or fast forward respectively.

## Playing Tracks on a USB Device in Random Order

There are two possible Random settings for a USB device: Random All and Random Folder (If the content of the USB device is stored in folders).

To play tracks in random order, do the following:

- 1 Press the “MENU” button
- 2 Push Up button or Down button until “RANDOM” is displayed.
- 3 Enter Random Sub menu by pressing “OK” button.
- 4 Push Up button or Down button to choose between All and Folder.
- 5 Push “OK” button to activate the desired Random mode.

### **Repeating Tracks on a USB Device**

There are three possible Repeat settings for a USB device: Repeat All, Repeat track and Repeat Folder (If the content of the USB device is stored in folders). By default, Repeat All is active.

To change the repeat setting, do the following:

- 1 Press the “MENU” button
- 2 Push Up button or Down button until “REPEAT” is displayed.
- 3 Enter Repeat Sub menu by pressing "OK" button.
- 4 Push Up button or Down button to choose between All, Track and Folder.
- 5 Push “OK” button to activate the desired Repeat mode.

### **Changing to another Folder on a USB**

If the content of the CD is stored in folders, it is possible to change folders directly. To do this, push either the Up button or Down button to move to the next or previous album/folder respectively.

### **Scan a USB**

When USB is scanned, the first 10 seconds of each track is played.

To activate Scan, do the following:

- 1 Press the “MENU” button.
- 2 Select “SCAN” by pressing “OK” button.

Scanning will stop when:

- 1 The “ESC” or “OK” button is pressed. OR
- 2 All tracks are browsed through.

## **iPod Mode**

The radio supports iPod Classic, iPod Video, and iPod nano. The iPod settings, e.g. Shuffle or Repeat, used prior to connecting the iPod to the radio will be used by the radio. An iPod device must be connected prior to operating in this mode.

## **Connecting the iPod**

Connecting the iPod can be done with two different cable sets:

- A split cable from the iPod 30-pin connector to a USB connector and a 3.5 mm audio connector.
- A separate iPod/USB cable plus a 3.5 mm male/male stereo audio cable connected to the iPod earphone output. The iPod volume should in this case be set to maximum prior to connecting to the radio.

When the iPod is connected to the radio, the iPod’s controls will lock. All control of the iPod is done by the radio buttons. When in this state, the iPod will display a Volvo logotype.

## **Switching to iPod Mode**

There are two ways to switch to iPod mode:

- 1 Push the CD/AUX button until iPod shows on the display. OR
- 2 Connect an iPod device.

## **Disconnecting the iPod device**

No special preparations are needed to disconnect the iPod device. When the iPod device is removed the radio will play the previous audio source.

## iPod Menu

When iPod is connected and source, the user can push and hold the “ESC” button to enter the iPod Menu.

This Menu contains some of the most common functions used in the iPod. E.g. the user can search for Artists and Albums, as well as starting a Playlist.

Push and hold the “ESC” button for 1 second to enter the iPod Menu at last used level.

Push and hold the “ESC” button for 2 seconds to enter the iPod Menu at top level.

## Changing a Track on iPod

There are two ways to change a track:

- 1 Push and release the “OK” button or the “ESC” button on the radio to move to the next or previous track respectively. OR
- 2 Using the steering wheel controls: Push and release Seek buttons to move to the previous or next track respectively.

## Fast Reverse or Fast Forward on an iPod

Fast forwarding or reversing can be performed in one of two ways:

- 1 Push and hold the “OK” button to fastforward. OR
- 2 Using the steering wheel controls: Push and hold Seek buttons to move to fast reverse or fast forward respectively.

### **Note!**

Push and hold the “ESC” button will enter the iPod menu.

## Playing Tracks on iPod in Random Order

There are two possible Random settings for iPod: Random Album and Random All.

To play songs in random order, do the following:

- 1 Press the “MENU” button
- 2 Push Up button or Down button until “RANDOM” is displayed.

- 3 Enter Random Sub menu by pressing “OK” button.
- 4 Push Up button or Down button to choose between All and Album.
- 5 Push “OK” button to activate the desired Random mode.

## Repeating a Track on iPod

There are two possible Repeat settings for iPod: Repeat One, and Repeat All.

To change the repeat setting, do the following:

- 1 Press the “MENU” button
- 2 Push Up button or Down button until “REPEAT” is displayed.
- 3 Enter Repeat Sub menu by pressing “OK” button.
- 4 Push Up button or Down button to choose between All, track and folder.
- 5 Push “OK” button to activate the desired Repeat mode.

## Scan iPod

When iPod is scanned, the first 10 seconds of each track is played.

To activate Scan, do the following:

- 1 Press the “MENU” button.
- 2 Select “SCAN” by pressing “OK” button.

Scanning will stop when:

- 1 The “ESC” or “OK” button is pressed. OR
- 2 All tracks are browsed through.

## AUX Mode

To select an auxiliary audio input:

Push the “CD/AUX” button until “Aux” shows on the display.

An auxiliary audio input may be selected except when in iPod mode. The output volume of the Aux device should be set to maximum. Please note that for an Aux device, changing tracks, fast forwarding etcetera must be done directly on the Aux device.

## Audio Settings

### Adjusting Volume Up and Down

The audio systems volume can be adjusted up by turning the Rotary knob in a clockwise direction and adjusted down by turning the knob in a counter-clockwise direction.

It can also be adjusted up and down by using the + and — on the steering wheel controls respectively.

### Adjusting Bass Up and Down

The audio systems bass can be adjusted by pressing the “AUDIO” button until “BASS” shows on the display. The bass is then adjusted up by turning the Rotary knob in a clockwise direction and adjusted down by turning the knob in a counter-clockwise direction. It can also be adjusted up and down by using the “OK” button or the “ESC” button on the radio respectively.

### Adjusting Treble Up and Down

The audio systems treble can be adjusted by pressing the “AUDIO” button until “TREBLE” shows on the display. The treble is then adjusted up by turning the Rotary knob in a clockwise direction and adjusted down by turning the Rotary knob in a counter-clockwise direction. It can also be adjusted up and down by using the “OK” button or the “ESC” button on the radio respectively.

### Adjusting Balance Left and Right

The audio systems balance can be adjusted by pressing the “AUDIO” button until “BALANCE” shows on the display. The balance is then adjusted right by turning the Rotary knob in a clockwise direction and adjusted

# 420 Radio/CD

---

left by turning the Rotary knob in a counter-clockwise direction. It can also be adjusted right and left by using the “OK” button or the “ESC” button on the radio respectively.

## **Adjusting Fader Front and Back**

The audio systems fader can be adjusted by pressing the “AUDIO” button until “FADER” shows on the display. The fader is then adjusted front by turning the Rotary knob in a clockwise direction and adjusted back by turning the Rotary knob in a counter-clockwise direction. It can also be adjusted front and back by using the “OK” button or the “ESC” button on the radio respectively.

## **Adjusting Mid (Medium Frequency Range) Up and Down**

The audio systems fader can be adjusted by pressing the “AUDIO” button until “MID” shows on the display. The mid is then adjusted up by turning the Rotary knob in a clockwise direction and adjusted down by turning the Rotary knob in a counter-clockwise direction. It can also be adjusted up and down by using the “OK” button or the “ESC” button on the radio respectively.

## **Speakers Selection fmfh mid**

The audio system can be adjusted to 4 or 2 speaker mode by performing the following:

- 1 Press the “MENU” button.
- 2 Push Up button or Down button until “ADVANCE” is displayed.
- 3 Press the “OK” button to enter the Advance submenu.
- 4 Push Up button or Down button until “SPEAKERS” is displayed.
- 5 Change between 2CH and 4CH by pressing the “OK” button.

### **Activate Speed Dependant Volume (ASC)**

The audio systems volume can be set to increase with the speed of the vehicle. This is sometimes preferred to compensate for road and engine sounds. The feature can be set to three levels of sensitivity, LOW, MID and HIGH.

To activate ASC, perform the following:

- 1 Press the “MENU” button.
- 2 Push Up button or Down button until “ADVANCE” is displayed.
- 3 Press the “OK” button to enter the Advance submenu.
- 4 Push Up button or Down button until “ASC” is displayed.
- 5 Press the “OK” button to enter the ASC submenu.
- 6 Push Up button or Down button to choose between LOW, MID and HIGH.
- 7 Press the “OK” button to enter the desired ASC setting.

### **Bluetooth Hands free Phone Mode**

The radio is designed to work with mobile phones that support the Bluetooth Hands Free Profile 1.5. Other Bluetooth capable mobile phones may still work with the radio though.

To connect a mobile phone to the radio through Bluetooth, the following steps must be completed on the radio.

- 1 Activate the Bluetooth function.
- 2 Add the Phone.

### **Bluetooth Activation**

The purpose of this process is to make a Bluetooth connection possible.

- 1 Push the “MENU” button.

#### **Note!**

Corresponding steps have to be taken on the mobile phone. An added phone will be stored in a list for quick access when connecting at another time.



## 422 Radio/CD

---

- 2 Push Up button or Down button until “Hands Free” is displayed.
- 3 Push the “OK” button to enter the Hands Free sub menu.
- 4 Push the “OK” button to activateBluetooth.

When Bluetooth is active, the display shows an icon.

### Adding a Phone

The purpose of this process is to make a connection between the radio and a phone as well as to add a phone to the radio phone list, in which the radio can store up to 16 different phones.

- 1 Push the “MENU” button.
- 2 Push Up button or Down button until “Hands Free” is displayed.
- 3 Push the “OK” button to enter the Hands Free sub menu.
- 4 Push Up button or Down button until “Add phone” is displayed.
- 5 Push the “OK” button to initiate the phone connection.

The radio will now do a search for a blue tooth phone. This is indicated by the Bluetooth icon blinking. Note that the phone must be in a corresponding connecting state during this process. When a connection is established, the user will be prompted to enter a code on the phone. Enter code 0000 to verify connection.

### Activating another Phone

The purpose of this process is to disconnect a present bluetooth phone and establish a connection to another phone in the phone list.

- 1 Push the “MENU” button.
- 2 Push Up button or Down button until “Hands Free” is displayed.
- 3 Push the “OK” button to enter the Hands Free sub menu.

### Note!

If the phone list already contains 16 different phones, the message "PHONE LIST FULL" will be shown in the display.

- 4 Push Up button or Down button until the display shows “ChangePhName” (where “PhName” will be the name of the presently connected phone).
- 5 Push the “OK” button to enter the Change phone sub menu.
- 6 Push Up button or Down button until the phone name that is to be connected is displayed.
- 7 Push the “OK” button to connect to the other phone.

### **Deleting a Phone**

The purpose of this process is to delete a specific phone from the phone list in the radio.

- 1 Push the “MENU” button.
- 2 Push Up button or Down button until “Hands Free” is displayed.
- 3 Push the “OK” button to enter the Hands Free sub menu.
- 4 Push Up button or Down button until “Edit Phone” is displayed.
- 5 Push the “OK” button to enter the Edit phone sub menu.
- 6 Push Up button or Down button until the phone name that is to be deleted is displayed.
- 7 Push the “OK” button to delete the phone.
- 8 The display will show “Delete?”. Push the “OK” button to verify.

### **Deleting all Phones**

The purpose of this process is to delete all phones from the phone list in the radio.

- 1 Push the “MENU” button.
- 2 Push Up button or Down button until “Hands Free” is displayed.
- 3 Push the “OK” button to enter the Hands Free sub menu.

- 4 Push Up button or Down button until “Edit Phone” is displayed.
- 5 Push the “OK” button to enter the Edit phone sub menu.
- 6 Push Up button or Down button until “Delete All” is displayed.
- 7 Push the “OK” button to delete all phones.
- 8 The display will show “Are U sure?”. Push the “OK” button to verify.

### **Accept call**

To answer an incoming phone:

- 1 Press the “OK” button. OR
- 2 Press the “YES” button on the steering wheel.

### **Outgoing call**

Use your mobile phone to dial/connect the call. If the mobile phone is connected to the Handsfree system the call will be automatically transferred to the Handsfree system.

### **Transfer call between Bluetooth Handsfree and mobile phone**

Press the “AUDIO” button to transfer the phone call back and forth between the Handsfree and the mobile phone.

### **Note!**

When leaving the truck during a call via Bluetooth Handsfree, the call should be manually transferred to the mobile phone.

### **End or reject call**

To end a call or to reject an incoming call:

- 1 Press the “ESC” button. OR
- 2 Press the “NO” button on the steering wheel.

## Clock

### Displaying the Time

By default, the time of day is displayed only when the ignition is ON and the radio is OFF. The Clock can be set to show the time also when radio is ON, by doing the following:

- 1 Push the “MENU” button.
- 2 Push Up button or Down button until “CLOCK” is displayed.
- 3 Push the “OK” button to enter Clock sub menu.
- 4 Push Up button or Down button until “VISIBLE” is displayed.
- 5 Push the “OK” button to change between ON/OFF status.

### 12- or 24-Hour Format

The clock can be set to 12-hour or 24-hour mode. The 12-hour mode distinguishes between AM and PM. To change the time format, do the following:

- 1 Push the “MENU” button.
- 2 Push Up button or Down button until “CLOCK” is displayed.
- 3 Push the “OK” button to enter Clock sub menu.
- 4 Push Up button or Down button until “12/24 HR” is displayed.
- 5 Push the “OK” button to change between 12H or 24H options.

### Setting the Clock

To set the clock manually, do the following:

- 1 Push the “MENU” button.
- 2 Push Up button or Down button until “CLOCK” is displayed.
- 3 Push the “OK” button to enter Clock sub menu.

#### **Note!**

Normally the time is set automatically by the trucks system. The option to manually set the time will then not be available.

- 4 Push Up button or Down button until “SET TIME” is displayed.
- 5 Push the “OK” button to enter the Set time sub menu.
- 6 Push Up button or Down button to adjust the hours up or down respectively.
- 7 Push the “OK” button to set the hour and toggle to the minute adjustment.
- 8 Push Up button or Down button to adjust the minutes up or down respectively.
- 9 Push the “OK” button to save the time and finish the process.

### **Turning the alarm ON or OFF**

To set turn On or Off the Alarm time, do the following:

- 1 Push the “MENU” button.
- 2 Push Up button or Down button until “Wake Up Alarm” is displayed.
- 3 Push the “OK” button to enter Wake up alarm sub menu.
- 4 Push Up button or Down button until “On/Off” is displayed.
- 5 Push the “OK” button to change the alarm status.

### **Setting the Alarm**

To set the Alarm time, do the following:

- 1 Push the “MENU” button.
- 2 Push Up button or Down button until “Wake up alarm” is displayed.
- 3 Push the “OK” button to enter Wake up alarm sub menu.
- 4 Push Up button or Down button until “SET TIME” is displayed.
- 5 Push the “OK” button to enter the Set time sub menu

- 6 Push Up button or Down button to adjust the hours up or down respectively.
- 7 Push the “OK” button to set the hour and toggle to the minute adjustment.
- 8 Push Up button or Down button to adjust the minutes up or down respectively.
- 9 Push the “OK” button to save the time and finish the process.

## **Anti Theft Code (Guard)**

The radio unit is set to function with only one vehicle. The Guard feature prohibits operation of the radio anywhere else. The Guard is automatic and no manual handling is normally needed.

### **In case of malfunction**

If, by some reason, the radio fails in detecting the required vehicle, the user will be prompted to enter the Anti Theft Code (sticker found in Drivers Handbook). The display will then show "CODE 0000". Please note that this is a malfunction and should be checked at an authorized workshop. To enter the code, do the following:

- 1 For the current (blinking) digit, turn the volume knob until the right number is shown.
- 2 Press the power button to enter the digit. The next digit will start to blink.
- 3 Repeat step 1 and 2 until all four digits has been entered.

The user has three tries to enter the code. If these are unsuccessful the radio will be locked for 60 minutes until three new tries are allowed.

### **Deactivating Guard**

It is possible to deactivate Guard, but (is) not recommended. To deactivate the Guard function, do the following:

- 1 Push the “MENU” button.

- 2 Push Up button or Down button until “ADVANCE” is displayed.
- 3 Push the “OK” button to enter Advance sub menu.
- 4 Push Up button or Down button until “GUARD” is displayed.
- 5 Push the “OK” button to enter.
- 6 Push the “OK” button to set Guard ON or OFF.

The user will be requested for the Anti Theft Code to deactivate or activate Guard. The display will then show "CODE 0000" with the first digit blinking. To enter the code, do the following:

- 1 For the current (blinking) digit, turn the volume knob until the right number is shown.
- 2 Press the power button to enter the digit. The next digit will start to blink.
- 3 Repeat step 1 and 2 until all four digits has been entered.

The user has three tries to enter the code. If these are unsuccessful the radio will be locked for 60 minutes until three new tries are allowed.

## Tips and tricks

### USB and MP3

- WMA and MP3 are the only formats readable by the device.
- Playlist must be in .PLS or .M3U format.
- If the USB device does not work together with the radio, please try to reconnect the USB device which in some cases solves the problem.
- Some USB devices comes with extra software installed which makes them not compatible with the USB Mass Storage Device Class Standard. If this is the case, formatting the USB device can sometimes solve the problem.

### **Note!**

Formatting the unit will erase all data on the USB device, so make a back-up of the data before trying this action.

## Bluetooth

- Compatible with standard 1.5. (In order to see if your phone supports the Bluetooth Hands-Free Profile 1.5 please visit the Bluetooth organization homepage, <https://www.bluetooth.org/tpg/listings.cfm>, and search for the detailed specifications of your phone. (Note that the link above could change if the structure of the Bluetooth homepage is updated.)) You can also contact your cellular supplier to get the details directly from them.
- More information at [www.bluetooth.org](http://www.bluetooth.org).

## iPod

- The radio is designed to support the following iPod models (note that both older and newer generations of these iPods may also work): iPod nano - 1st, 2nd, and 3rd generation iPod classic - 5th and 6th generation
- iPod adapter can be found at e.g. [www.sendstation.com](http://www.sendstation.com).
- For best performance, the iPod firmware should be recently updated [www.apple.com](http://www.apple.com).

## CD, MP3, and WMA

- A CD with MP3 or WMA will take several seconds to read before it starts playing.
- For best performance, a MP3/WMA CD should not contain other file types than MP3, WMA, M3U and PLS.



# 430 Telephone

---

## Getting started

### Turning on the telephone

- 1 Turn the ignition key to drive or radio position.
- 2 Hold ON/OFF in until the green lamp lights



J3014429

### Turning off the telephone

Hold ON/OFF until the telephone is turned off. The green lamp in the button goes out.

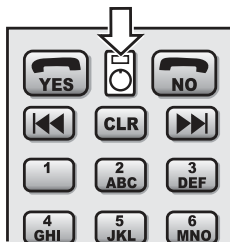

J3014429

## Insert the SIM card

The telephone can be used with a mini-SIM card only. The SIM card is provided by your network operator.

The SIM card can be mounted in only one way round in the card slot.



J3015501

## Enter your PIN code.

You will receive a PIN code together with your SIM card that in some cases is activated when the SIM card is inserted for the first time. You must enter your PIN code in order to use the telephone. This code must be entered every time the telephone is turned on. You can turn off this code in menu 5.4

- 1 Enter the code
- 2 Press YES

If the wrong PIN code is entered too many times in succession, the telephone will request a PUK code instead. The PUK code is also supplied together with your SIM card.

## Change language

- 1 Go to telephone mode (YES)
- 2 Press in rapid succession (within three seconds):  
>>  
5  
3

# 432 Telephone

---

3 Select the desired language from the list

## Telephone position

Once the telephone has been turned on, the driver's display will show information concerning the telephone; the driver's display will be in telephone mode.

Return to information mode by pressing NO on the keypad or from the steering wheel by pressing the ESC stalk switch.

The driver's display must be in telephone mode before the telephone can be used. Go to telephone mode by pressing YES on the keypad or from the steering wheel, or by entering a telephone number on the keypad.

Go to radio mode from information mode by pressing >> or << on the steering wheel.

Go from telephone mode to

- the telephone directory with <<
- the menus with >>
- the latest dialled number with YES



The symbol that is shown when the display is in telephone mode.



The symbol that is shown when the display is in radio mode.

## Calling

### Making a call

1 Go to telephone mode (YES)

2 Dial the number, including the area code

If it is wrong:

- Delete the last dialled number with CLR
- Delete a figure in the middle of the number by stepping with the arrows until the cursor is beneath the figure and press CLR.

3 Press YES or lift the handset

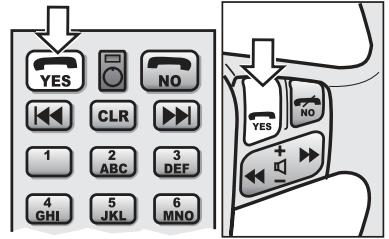

J3014428

## Answering a call

Press YES or lift the handset

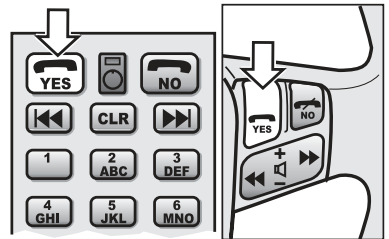

J3014428

## Finishing a call

Press NO or replace the handset

Your sound system will return to the same volume as before the call.

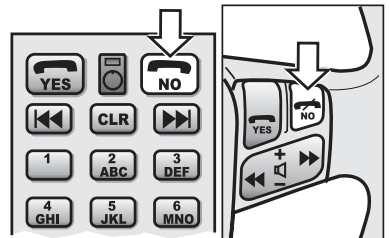

J3014427

## Making an emergency call

You can always make an emergency call, even without the ignition key and without a SIM card. The truck's main switch must be turned on.

1 Hold ON/OFF in until the green lamp lights

# 434 Telephone

---

- 2 Dial the SOS number (112 in EU)  
You can even dial the alarm number in the PIN code menu.
- 3 Press YES on the button pad or lift the handset

## Last dialled numbers

The telephone stores the last dialled number or name automatically.

- 1 Go to telephone mode (YES)
- 2 Press YES to show the numbers
- 3 Move to the right number with >> and <<
- 4 Press YES to call the number

## Telephone directory

The telephone directory can store 99 names and numbers. Additional names and numbers can be stored on the SIM card.

### Search the directory

- 1 Go to telephone mode
- 2 Press <<
- 3 Press YES
- 4 Step through the numbers until you find the number you want to call
- 5 Press YES

### Search for a name

- 1 Go to telephone mode
- 2 Press <<
- 3 Enter the first letter or letters of the name
- 4 Press YES
- 5 Step through the names using the arrow keys until you find the right one
- 6 Press YES to ring up

## While making a call

### Change volume

The volume can be adjusted using + and - on the steering wheel.

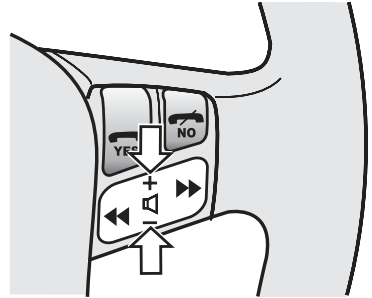

J6008661

### Respond to call waiting during a call

Press YES to answer the call.

Press NO to decline from answering the call.

The busy tone is given to the person ringing you.

### Call menu

The call menu can be accessed during a call by pressing << or >>. Press NO to return to showing telephone number and call time.

Menu	Note
Confidential	Turn off the microphone so that the caller cannot hear what is being said.
Hold	Disconnect the caller temporarily so that you can call a third party. When the third party has answered, one can switch between the calls using "Switch" or connect them together with "Connect".
Handset	Use the handset
Handsfree	Using handsfree.
Memory	Go to the telephone directory.
Connect	Talk to both parties at the same time. (If two calls are being made.)

# 436 Telephone

---

Menu	Note
Switch	Switch between two calls. (If two calls are being made.)

## Managing messages

There are more message functions than those described here. See the section about menus for a list of all the functions under menu 2, Messages. You cannot manage messages while driving.

## Write and send messages

1 Go to telephone mode (YES)

Operator  << Memory Menu >>
--------------------------------

2 Go to menu 2, "Messages"

Menu 2  << Messages>>
--------------------------

3 Press YES

4 Go to menu 22, "Write"

Menu 22  << Write >>
-------------------------

5 Press YES

6 Write the message:

Press the key with the letter you want to write. Press once for the first letter, twice for the second and so on.

Delete with "CLR".

Button	Character
1	[ ] 1 - ? ! , . : " ' ( )
2	a b c 2 ä å à á â æ ç

Button	Character
3	d e f 3 è é é ê
4	g h i 4 î ï ð
5	j k l 5
6	m n o 6 ñ ò ó ô õ
7	p q r s 7 ß
8	t u v 8 ü ú û û
9	w x y z 9
*	Space
0	+ 0 @ * # & \$ £ / %
#	Change between lower to upper case

**7** Press YES

**8** Select "Send" or "Save"

Saved messages can be found under menu 21, "Read", and can be sent later.

Press several times on NO or hold NO to return to telephone mode.

## Read a message

An envelope on the display indicates an incoming message.



Symbol for message

**1** Go to menu 2, "Messages"

**2** Press YES

**3** Go to menu 21, "Read"

**4** Press YES

**5** Select which message you want to read. New messages are marked with "N", read messages with "R" and saved messages with "S". In addition to whether the message is new, read or saved, the sender of the message and when it arrived is also shown.



# 438 Telephone

---

**6** Press YES

**7** Read message

**8** Press YES

**9** Choose between delete, answer, edit, send, ring sender or save number.

**10** Press YES to select

or

Press NO to not select any alternative.

Press several times on NO or hold NO to return to telephone mode.

## Menus

### Step between the menus

Go to telephone mode (YES). Press >> to access the menus.

- Step between submenus with >> and <<
- Step from one menu to a submenu with YES
- Confirm or select by pressing YES
- Undo or say no to an alternative by pressing NO briefly.
- Return to telephone mode by holding down NO

Example:

You are in telephone mode and want to change the ring signal.

- 1 Press >> to access the menus
- 2 Step through with >> or << until you come to menu 5, settings
- 3 Press YES to select the settings menu
- 4 Step through until you come to the sounds submenu
- 5 Select the sounds submenu
- 6 Step through to the ring signal submenu
- 7 Select the ring signal submenu
- 8 Step through to the desired ring signal
- 9 Select the desired ring signal

You have now changed the ring signal. Press several times on NO or hold NO to return to telephone mode.

## Jump directly to a menu

Instead of stepping through all the menus, you can jump directly to a menu by entering the menu number rapidly (within three seconds).

- 1 Press >> to access the menu system.
- 2 Press the number of the desired main menu.
- 3 Press the number of the desired submenu.

Example:

You are in telephone mode and want to change the ring signal. Press rapidly:

>>

5

6

2

Change to the desired ring signal

## Menus, overview

Only some of the menus are available when driving.

# 440 Telephone

---

Menu	Note
<b>1 Call log</b>	Information on incoming and outgoing calls is stored here.
11 Missed calls	Choose between ring, save, or delete each number.
12 Received calls	Choose between ring, save, or delete each number.
13 Called numbers	Choose between ring, save, or delete each number.
14 Delete list	
141 All	
142 Missed	
143 Received	
144 Ringed	
15 Message length	
151 Last call	
152 Number of calls	
153 Total time	
154 Reset	To reset the call information, you must enter the telephone code. The code is 1234 for a new telephone but can be changed in menu 552.

Menu	Note
<b>2 Messages</b>	If Dynafleet is on, the menu "Messages" is inhibited and all managing of messages is then via Dynafleet.
21 Read	New messages are marked with "N", read messages with "R" and saved messages with "S". Any message can be deleted, answered, edited and forwarded. The sender can be called and the number can be saved.
22 Write	
23 Speech message	Enter the number of your voice mailbox.
24 Settings	
241 SMSC number	The SMSC number is to your operator's message centre and is provided together with the SIM card.
242 Validity	Specify how long the message is to be saved in the message centre. The telephone operator will try to send the message to your telephone for as long as the message is saved at the message centre.

Menu	Note
243 Type	Specify the type of message to send.

Menu	Note
<b>3 Edit memory</b>	
31 Add	Add a name and telephone number. Choose to save it to the telephone memory or the SIM-card memory.
32 Search	Search using the first letter(s) of a name. Choose to edit, delete, copy or move the number. Copying implies that the number is copied so that it is in both telephone memory and SIM-card memory. Moving implies that the number is moved from the telephone memory to the SIM-card memory or visa-versa.
33 Speed dial	Stores a number on a rapid dial button. First choose the speed dial button (1-9) then search for the number in the memory to be stored on it.
34 Empty SIM	Delete all numbers stored on the SIM-card.
35 Empty memory	Delete all numbers stored in the telephone memory.
36 Status	Shows the number of used memory slots in the telephone and SIM-card memories. The maximum number of memory slots is shown in brackets.

Menu	Note
<b>4 Call functions</b>	
41 Send number	Select if your telephone number should be seen by the receiver when calling from the phone.
42 Call waiting	Choose whether to answer other calls while talking in the telephone.
43 Auto-answer	Select if the telephone should answer all incoming calls automatically.
44 Auto-redial	With auto re-dial the telephone will automatically try to redial if a number is busy.
45 Speed dial	Choose whether to allow dialling with speed dial.
46 Forwarding	Select if the call should be forwarded and to which number.
461 All calls	
462 When busy	

# 442 Telephone

---

Menu	Note
463 No reply	Forwarding with no reply. The number of ring signals permitted depends on your operator.
464 Unavailable	Forwarding if the telephone is in an area of poor coverage.
465 Fax poll	Forwarding when the call comes from a fax.
466 Data poll	Forwarding when the call comes from a computer, i.e. if GSM-data is transferred to the telephone.
467 Cancel all	Cancel all forwarding.

Menu	Note
<b>5 Settings</b>	
51 Factory settings	Resets the telephone to the settings that applied from the factory (affects language, operator, ring volume, ring signal, button click, speed-dependent volume, radio auto-mute, Dynafleet)
52 Operator	Choose if the telephone should search for another operator when it cannot find own operator or if you should select between operators available.
53 Language	Choose language.
54 SIM-security	With SIM-security "On", the PIN code must be entered every time the telephone is switched on. With SIM-security "Off" the PIN code never needs to be entered when the telephone is switched on. With SIM-security "Auto" the PIN code only needs to be entered when the telephone is switched on if the SIM-card is changed.
55 Change codes	
551 PIN code	You will receive a PIN code together with your SIM card. The PIN code can be changed here. The PIN code can be 4-8 numbers.
552 Telephone code	The telephone code is 1234 when the vehicle is delivered. You can change the telephone code here.
56 Sound	
561 Ring volume	Select the volume of the ring signal here. Change volume with << and >>. Go back to menu "Sound" with NO.
562 Ring signal	Select ring signal.
563 Button click	Select button click on or off.

Menu	Note
564 Speed-dependent volume	If Speed-dependent volume is on, then the volume will increase as the speed increases.
565 Radio auto-mute	If Radio auto-mute is on, the radio volume is reduced to zero when the phone rings.
57 Dynafleet status	Select if Dynafleet is connected or not. If Dynafleet status is set to connected, all messages are managed via Dynafleet. The telephone's menu 2 is not then available.

## Measures with malfunctions

### No contact with the display

If, for any reason the telephone loses contact with the display, it will function anyway. To dial a number, enter the number and press YES.

### Faulty handsfree or handset

If the handsfree does not function, the telephone automatically shuts off the handsfree and only the handset can be used. The same applies if the handset does not function.

## **Booster**

Volvo's multi-channel booster VA 400.8 is a premium-class eight-channel power amplifier for motor vehicles. It has integrated cross-overs for all channels and a number of sub-woofer controls for individual adjustments. The booster is factory installed and preset to give a natural and well balanced sound.

## **Installation**

Volvo's multi-channel booster VA 400.8 is factory installed according to Volvo's demands, which guarantees safe use for all types of operation. Any modifications of the factory installation can cause damage to the booster and void the guarantee.

## **Methods of use**

Volvo's multi-channel booster VA 400.8 is safe to use within these specifications according to Volvo's specified methods of use.

## **Fuses**

Volvo's multi-channel booster VA 400.8 is equipped with external fuses of 2×15 A. If the fuses should blow, contact Volvo Action Service or a Volvo workshop.

## **Indicator lamps**

Volvo's multi-channel booster VA 400.8 has a green lamp for POWER and a red lamp for PROTECTION (protected mode). The green lamp lights when the booster is turned on and functions normally. The red lamp lights if the booster is in protected mode. If the red lamp does not reset automatically after a certain time, contact Volvo Action Service or a Volvo workshop.

## Subwoofer controls and switch

It is possible to make adjustments to Volvo's multi-channel booster VA 400.8 to optimize the subwoofer performance in different vehicles.

**Volume:** Scale range: 0 dB–12 dB steplessly adjustable

The dot on the scale is Volvo's reference setting.

**LPF:** Scale range: 50 Hz–120 Hz steplessly adjustable

The dot on the scale is Volvo's reference setting.

**Phase adjustment:** Scale range: 0°–180° steplessly adjustable

The dot on the scale is Volvo's reference setting.

**Phase switch:** Positions: NORMAL – INVERSE

NORMAL position is Volvo's reference setting.

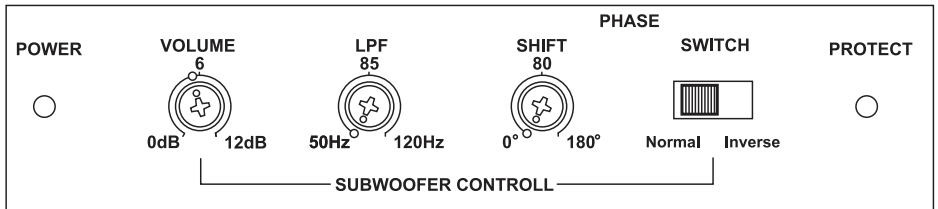

J8011992

## Fault tracing

**Fault:** The sound is shut off after a period of normal use.

**Information:** After a very high sound level for a long period and/or high temperature in the baggage/storage area, the booster can go to protected mode due to overheating. The sound is shut off and the red lamp lights.

**Action:** Lower the volume on the main unit to level 10 and wait for the sound to return.



## 446 **Booster**

---

If the sound does not return or if Volvo's multi-channel booster VA 400.8 should not function due to another reason, contact Volvo Action Service or a Volvo workshop.

## Dynafleet

Dynafleet is a system for transport planning combined with vehicle planning, message handling and automatic reporting of vehicle status and driver times.

The driver communicates continually with the office. The traffic officer in the office can direct the vehicle to various places for various missions. The driver can send messages to other drivers, to the office or privately. Contact between the driver and the office means that much of the order administration can be administered in a simple way and more effective manning of transport is achieved. Communication with the central office takes place via the GSM mobile phone network.

The system collects information from the tachograph and the engine control unit. Dynafleet provides the driver with information about the vehicle and driving activities. This makes it possible to have a better transport administration and follow-up of the running costs of the vehicle, the work contribution of the driver and how economically the driver drives.

The section "Design and function" describes the most basic functions that all drivers must be familiar with. In the "System management" section there is a system overview and a description of how the system is started. The remaining sections describe the system functions in more detail.

## Technical description

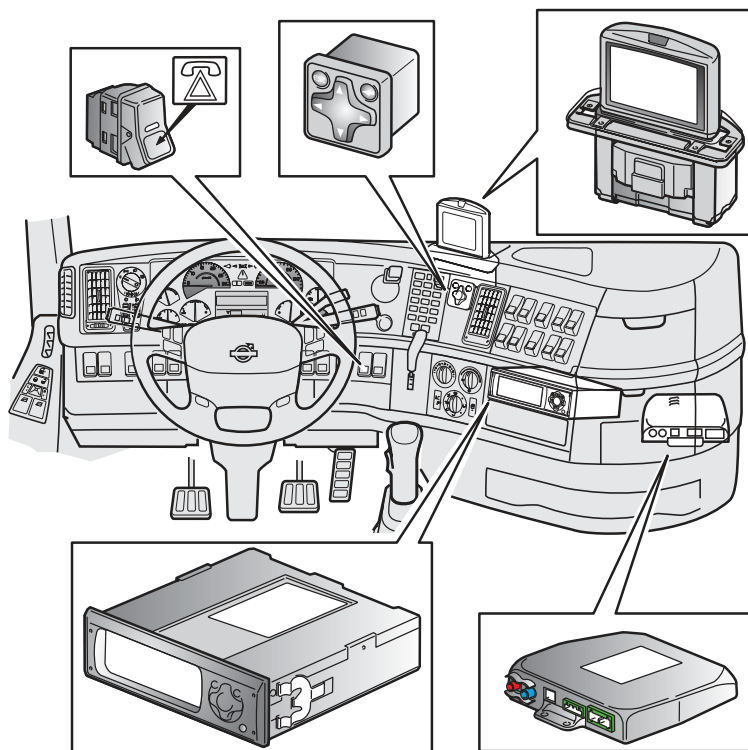

J3019628

Dynafleet comprises two units, Dynafleet Gateway and Dynafleet Driver Tool. Dynafleet Gateway has an assistance button located on the instrument panel.

Dynafleet Driver Tool has a keyboard and also has a separate colour display as an option. The Dynafleet unit is connected to various electronic control units and the tachograph via the vehicle's electronic network. Communication with the central office takes place via the GSM mobile phone network.

The Dynafleet Driver Tool is located in the instrument panel beneath the radio. The screen is located above

the dashboard. Dynafleet Gateway is located in the electrical distribution box.

Driver data is logged as four different types of activity: driving time, rest time, working time and waiting time. While the vehicle is in motion, the activity is automatically logged as driving time. When stationary, the logged activity is determined by the settings on the tachograph for driver 1. Information is taken directly from the tachograph.

All data is transferred to the office for further processing and follow-up. Transfer of vehicle data to the office is performed via the GSM network. If there is poor coverage, the information is stored temporarily in the Dynafleet system. Basic data reports are also transferred when required by the central office. The GPS receiver provides the system with correct system time and position.

### **Reduced functionality**

The system is developed for Volvo's FH and FM vehicles, but can be installed in any vehicle. This will, however, limit some of the functionality due to other vehicles having different types of tachograph, different electronic systems, etc., than the vehicles for which the system has been developed.

## Controls

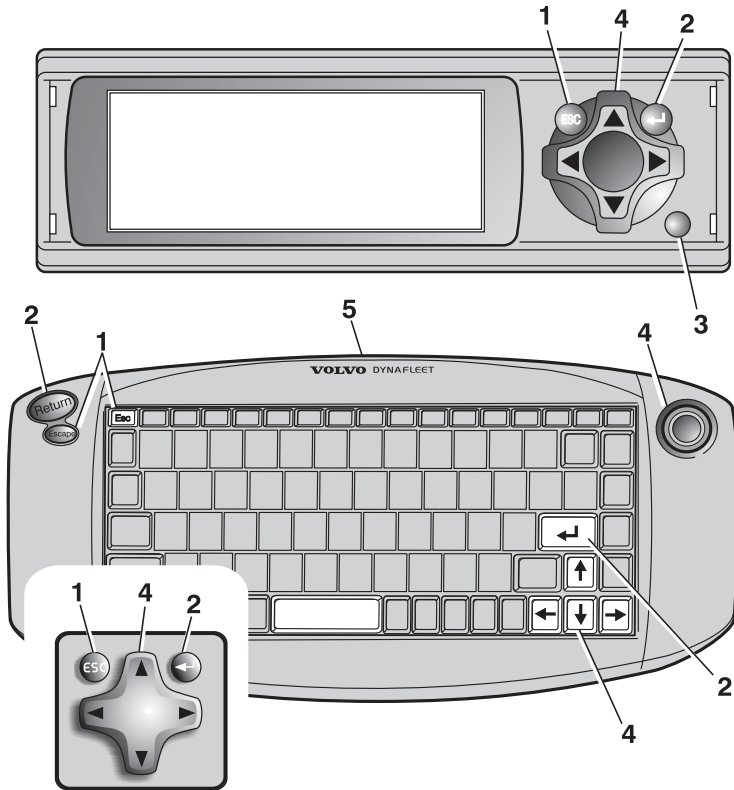

J3019842

- 1 "Esc" has two functions depending on the situation:
  - In forms where you can choose between different values, pressing "Esc" means that you cancels the setting.
  - In other cases, pressing "Esc" moves you up a level in the menu tree.
- 2 "Select" has three functions depending on the situation:

- With a question, pressing “Select” indicates a Yes answer to the question.
  - In forms where you can choose between different values, pressing “Select” means that you confirm and accept the current setting.
  - In a menu, pressing “Select” moves you to the active option, i.e. the highlighted submenu with white text on a black background.
- 3 IR receiver, receives signals from the keypad.
  - 4 “Arrow keys, right, left, up and down”, moves the cursor in the selected direction.
  - 5 IR transmitter, transmits signals to the Dynafleet unit.

## Keyboard

Use the keyboard to type messages. Do not expose the keyboard to sunlight, damp, moisture or dirt.

The IR transmitter on the keyboard must be directed towards the IR receiver on the Dynafleet unit when you type.

To switch between QWERTY and Cyrillic on the keyboard, press ALT and SHIFT at the same time, or CTRL and SHIFT at the same time.

## Note!

The keypad can only be used while the truck is stationary. Store the keypad in the glove compartment in the radio shelf while travelling. The keypad is then protected against the sun and will not move when braking suddenly or in a collision.

## Four-way directional cross

The standard functions in Dynafleet can be performed using the joystick which is located on the dashboard, near the steering wheel.

## Care of the plastic casing and IR transmitter/receiver

Clean with ordinary cleaning agents for vehicle interiors. Try first on a small area that is not visible so that the surface is not damaged.

Check that the lenses on the IR transmitter and the IR receiver are clean, if the system does not react to keyboard messages. The lenses should be cleaned with a soft, clean and slightly damp cloth.

## Emergency alarm button

There is an emergency alarm button in the instrument panel or on the radio shelf. The button must be held pressed in for at least three seconds for an alarm message to be sent. Depending on the settings for the office the request is sent to the office and VAS (Volvo Action Service) or Security Services. If the tool Dynafleet Driver is installed in the vehicle, pop-up messages inform the driver of status updates for the ongoing request.

### Extra equipment:

After using the emergency button or writing an assistance request you will always be called by an operator on a telephone number specified in the Dynafleet online portal. The intention of the call is to get confirmation of the action you initiated. If you do not receive such call within reasonable time, your initial request might have failed because of influences beyond our control. We then recommend trying to reach our services via more conventional methods.



J3011613

### Note!

The emergency assistance button only functions when the system is switched on or during standby. We advise adjusting the standby time to a suitable level to secure availability of the feature. (Standby time is configurable in the Dynafleet online portal. Check with the administrator to make these changes).

## Display

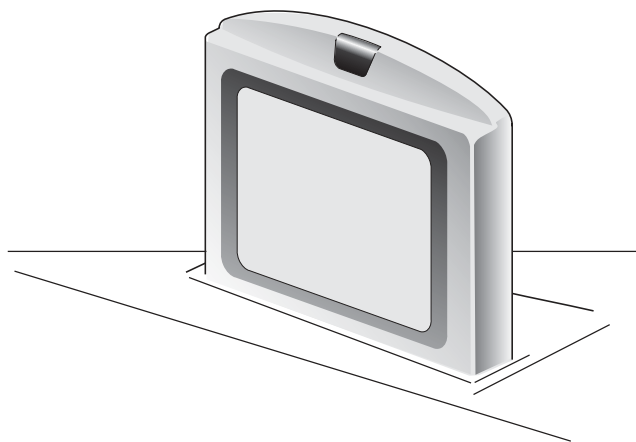

J3015818

The screen is mounted above the dashboard. The screen pops up or drops down automatically when the system is started or stopped.

Use a clean, soft and slightly damp cloth to clean the screen glass. Other plastic components can be cleaned with ordinary cleaning agents for car interiors.

**Note!**

Make sure the screen is not exposed to fluids.

## Menus and symbols

The menus vary in appearance. The relevant symbols and functions are described below.

### Standard menu

- 1 Symbol that indicates which part of the system you are viewing, i.e. Mail, Log, or Settings Menu.
- 2 Unread messages, shows that there are one or more messages in the message list.
- 3 The lower icon shows the GSM signal strength and the upper shows GPRS signal strength.
- 4 The currently active alternative is shown as white text on a black background.
- 5 Scroll-strip that shows if there is more information available. Depress "down" to show the information.



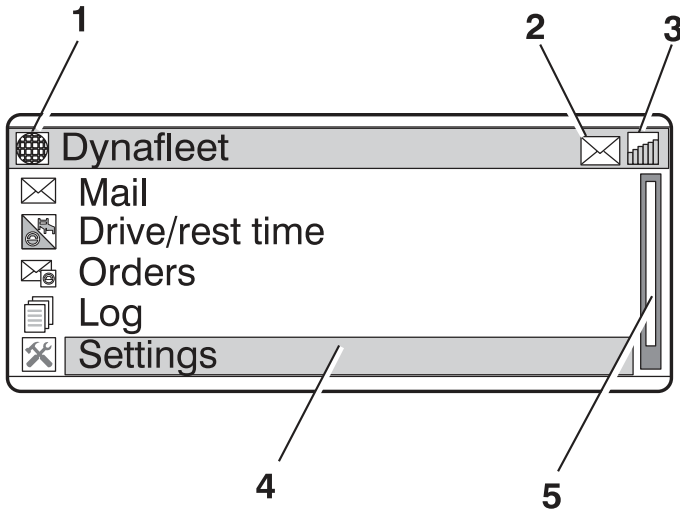

J3019630

## Using the menus

The example below describes how the menus in Dynafleet are used. The example shows how to send an SMS.

- 1 Set the cursor on "Mail" using the arrow keys.
- 2 Press "Select" to activate the mail menu.
- 3 Set the cursor on "Write new" using the arrow keys.
- 4 Press "Select" to continue.
- 5 Set the cursor on "SMS (standard characters)" using the arrow keys.
- 6 Press "Select" to write a new SMS.
- 7 Type in telephone number and message. Move the cursor between the different fields using the arrow keys.
- 8 Move the cursor to "Send" using the arrow keys.

- 9 Press "Select" to send the message.

## Starting the system

- 1 Turn the starter key. The system will start automatically when the key is in the radio position. The colour screen rises.
- 2 The system will automatically identify the driver by reading the driver card in the digital tachograph.
- 3 After the greeting you can begin to work with the system.

- 1 Turn the starter key. The system will start automatically when the key is in the radio position.
- 2 The system will automatically identify the driver by reading the driver card in the digital tachograph.
- 3 After the greeting you can begin to work with the system.

- 1 Turn the starter key. The system will start automatically when the key is in the radio position. The colour screen rises.
- 2 If the truck has an analogue tachograph, the driver is identified by logging in on the Dynafleet Driver Toolunit with information from the office.
- 3 After the greeting you can begin to work with the system.

- 1 Turn the starter key. The system will start automatically when the key is in the radio position.
- 2 If the truck has an analogue tachograph, the driver is identified by logging in on the Dynafleet Driver Toolunit with information from the office.

- 3 After the greeting you can begin to work with the system.

## Shutting off the system — stand by

When the key is turned to 0, the system goes to the standby mode. The screen shuts off and drops down if it is not already down. The system continues to log data when it is in the standby mode. After 2 hours (or some other time decided by the office) in standby mode, the system goes to a rest mode and stops logging data. The system can thereafter be woken up by an SMS, e.g. with temperature logging or location logging (the system is woken up by GSM communication).

The system is shut down completely only when the main switch is turned off. In this state, Dynafleet cannot receive GSM communications.



### Caution!

Wait for 3 minutes after you have stopped driving before you switch off the main electrical supply, otherwise data can be lost. Read more about how you switch off the main electrical supply in the “Driver instructions” section.

## Transferring data

The data collected and saved in the system is transferred to the fleet office where it is compiled and documented. Information is transferred to the office via the GSM network.

## General

The main menu consists of the following menu choices:

### Mail

Receive, send and manage messages.

### Drive/rest time

Shows driving and rest times.

### Orders

Receive and manage incoming orders.

### Log

Shows the vehicle's log.

### Emergency & Assist.

Shows status of on going Emergency assistance call.  
Send, view status of an Assistance call.

### Tacho. Remote dl.

Initiates driver card data or tachograph mass memory remote download and displays data transfer statuses.

### Settings

Managing settings in Dynafleet.

### Shut down

Puts Dynafleet in standby mode

Dynafleet
Mail
Drive/rest time
Orders
Log
Emergency & Assist.
Tacho. Remote dl.
Settings
Shut down

## Mail

In the mail menu, the driver can receive, send and manage messages.

When the Dynafleet-unit has received one or more messages, the symbol for new message is shown in the upper right of the display and the speaker sounds if it is switched on.

It is always possible to send simple text messages between the vehicle and the office. The office can decide to activate SMS, E-mail or formatted messages (predefined form to fill out).



## Mail menu

The mail menu consists of the following menu selections:

### Write new

Write a new mail. Choose between message to office, SMS or E-mail.

### Inbox

Read and manage received messages. Navigate to the position information if the GPS coordinator is connected to the mail menu (see the Navigation section).

### Outbox

Read and manage sent messages.

### Draft

Manage drafts.

### Sent

Manage sent messages.

### Address book

Manage contacts in the address book.

Meddelanden
Write new
Inbox
Outbox
Draft
Sent
Address book

## Two types of SMS characters that can be used

There are two types of text messages that can be used.

- Standard characters - Uses standard GSM characters which are not supported in all languages but are compatible with all mobile phones.
- Extended characters - Uses unicode which supports all languages. The message is shorter and the user should make sure that the receiver's mobile phone is compatible to receive this type of SMS message.

## Navigate to destination using navigation

The Dynafleet unit needs to be connected to a compatible navigation device. Contact your local dealer for more information.

If a message from the office contains position information, this can be sent to the navigation device from the unit. This is done from the message menu (press enter when viewing the message): a "Navigate to..." command can be selected to push the destination to the navigation device.

## General driving and resting times

The "Drive/rest time" menu is used to facilitate the observance of driving time regulations. The function is adapted to work in accordance with EU driving time regulations together with the tachograph. The settings can be changed and allow different driving times from the office.

### Main menu – Drive/rest time

The Drive/rest time menu consists of the following menu items:

**Show driver activities**, shows the times for all ongoing and accumulated times for driver activities.

**Enter detailed driver activities**, used by the driver to set a detailed activity while he is not driving.

The lower part of the display shows ongoing activities:  
TCO: current activity on the tachograph, accumulated activity time and ongoing activity time.

DTJ: current activity, accumulated activity time and ongoing activity time.

## Main menu – View driver activities

If any regulation is about to be broken, a warning is shown in the display. The office unit can be used to set how long before a regulation is broken a warning should be given.

Show driver activities	
Break time	01:00
Continuous driving	04:15
Continuous resting	00:30
Daily driving	08:45
1 week driving time	20:0
2 week driving time	75:0
Daily resting	01:30

### Break time

Time with activity Resting or Waiting since the current break period was started. A new break period starts when activity Driving or Working is detected.

### Continuous driving

Sum of Driving time since last qualified break time. It shall not exceed 4h30. It is reset to zero after 45 minutes or 15+30minutes of break time.

### Continuous resting

Duration of qualified break time. It adds times when exceeding the minimum breaks times (15, 30 or 45 minutes).

### Daily driving

Sum of Driving time since the current driving session was started. A new daily driving session starts the first time activity Driving is detected after the daily rest condition is fulfilled.

### 1 week driving time

Displays the total driving time for the current week. Starts after a weekly rest. The maximum is 6 continuous driving sessions within a week.

## 2 weeks driving time

Displays the total driving time for two weeks (last and current week). The time is not to exceed 90 hours.

## Daily resting

Cumulated resting time between two driving sessions. Shall be at least 9h (short daily rest) or 11h.

## Detailed driver activity

The detailed driver activity must first be enabled by the office before it can be used. It allows the driver to specify activity in addition to the tachograph resting/waiting/working activities. The select activity is reported back to the office. It can be selected in the "Set driver activity detail" menu or in the pop up window when turning key off. The activity ends when selecting another one or on driving.

Calculation of driving times at not affected by the selection of a detailed driver activity with the exception of "Ferry". The "Ferry" activity should be selected before going on ferry or train to comply with EU regulations.

## Orders

An order consists of the assignment, location, allocation status, planned arrival time and planned departure time. An order can be accepted or rejected by the driver. The driver can also report about an order's progress through the order status. When an order is received, an icon is shown at the top of the screen.

The appearance of the orders is decided individually by each office.



J200701

## Navigation (accessory)

The Dynafleet unit must be connected to a compatible navigation unit. Contact your local dealer for more information.



If an order from the office contains position information, this can be sent to the navigation system from the unit. This is done from the menu where the order is accepted. This selection is only available if the order has been accepted. The selection is made by pressing “Select” when the destination address is highlighted.

## Logs

Go to the journal menus by pressing the function key with the journal symbol or via the main menu.

From the main menu in the journal you can reach all accessible journals in the system .

Log
Trip log 1
Trip log 2
Vehicle long-term log
Temperature
1 Reset: 2008-06-03, 09:49 Vehicle log active
2 Reset: 2008-06-03, 15:02 Vehicle log paused

## Vehicle log 1 and 2

Shows accumulated vehicle data in absolute values and % of the distance since the last reset while active (not paused).

Trip log 1	
Distance	438.1 km
Fuel	163.2 litres
Average fuel consumption	37.2 l/100 km
Idling	21%
PTO	0%
AdBlue	6.2 litres
Economy zone	69%
Overspeed zone	1%
Rolling with engine disengaged	9%
Cruise control	22%
Speed limit exceeded	2%
Top gear	42%

## Vehicle long-term log

The vehicle long-term log shows the accumulated values for distance, fuel consumption and average fuel consumption.

Vehicle long-term log	
Distance	11523.2 km
Consumption	36814.8 l
Average fuel consumption	37.3 l/100 km

## Temperature

Requires extra equipment connected to Dynafleet unit.  
Contact your local dealer for more information.

This shows the temperature in the trailer. Up to four different temperatures can be shown, depending on how many sensors there are.

If a sensor has an alarm function, this is shown in red figures or with an exclamation mark (!), depending on which display the truck is fitted with

Temperature	
Temperature 1	-18 °C
Temperature 2	-7 °C
Temperature 3	+4 °C
Temperature 4	+12 °C !
Trailer doors	Closed
Defroster status	On

## Reset: 2008-06-02, 09:49

Shows the latest resetting date/time and allows the driver to reset the corresponding vehicle log.

## Vehicle log active or vehicle log paused

Used by the driver to change between paused and active vehicle log.

## Driver coaching

Driver coaching must first be activated by the office. It helps the driver to improve the fuel consumption by suggesting different actions in the pop-up window such as e.g.

- “You have been idling too long. Please turn off ignition.”
- “Shift up to improve fuel economy”
- “You are driving too fast. Please slow down.”

## Emergency & Assistance

### Assistance request

Send a request for assistance. Enter necessary information in the free-text field.

### Assistance status

This shows the status for sent assistance request: time it has been initiated, time received by office, time it has been attended to and the requesting driver name.

### Emergency status

This shows the status for sent emergency assist request: time it has been initiated, time received by office, time it has been attended to and the requesting driver name. Read more about the emergency assistance button, “Emergency assistance button” on page 452.

Statuses are erased 7 days after a request is initiated. The message is then “No ongoing request”.

On any status change, a pop up window will inform the driver of the new status.

Emergency & Assistance
Assistance request
Assistance status
Emergency status

## Tachograph download menu

### Tacho. Remote dl.

Go to the tachograph remote download menus via the main menu.

This function requires to have a digital tachograph supporting the remote download feature installed in the vehicle and the service to be enabled. Contact your local dealer for more information. This menu is not displayed if the function is not available.

An icon on the status bar informs the user of an ongoing remote download process running in the background. If the process fails, a specific icon is displayed and details are available in Driver or Tachograph data status menus.

Tacho. Remote dl.
Initiate driver card dl.
Driver data status
Initiate tacho. mem. dl.
Tachograph data status



This icon informs the user of an ongoing remote download process in the background.



This icon shows that the download process failed. Details are available in Driver or Tachograph data status menus.

## **Initiate driver card dl.**

Initiates a driver card data download from the tachograph to the office. A maximum of one transfer per day is allowed. Once initiated the process runs in the background and status is reported through popups and Driver data status menu.

This function requires the driver to be logged in on the Driver Tool using his driver card inserted in the tachograph (driver slot).

Greyed menu item means this function is disabled by office.

EU regulations require at least one transfer every 28 days or more frequent depending on country specific regulations.

## **Driver data status**

This menu informs the driver about driver data transfers:

- Current ongoing transfer: which driver has initiated the transfer and current status.
- Date of last successful transfer.
- Days since last data available at the office.
- Last warning message and date it was received.

## **Initiate tacho. mem. dl.**

Initiates a tachograph mass memory download from the tachograph to the office. A maximum of one transfer per day is allowed. Once initiated the process runs in the background and status is reported through popups and Tachograph data status menu.

Greyed menu item means this function is disabled by office.

EU regulations require at least one transfer every 90 days.

**Tachograph data status**

This menu informs the driver about tachograph mass memory transfers:

- Current ongoing transfer: which driver has initiated the transfer and current status.
- Date of last successful transfer.
- Days since last data available at the office.
- Last warning message and date it was received.

**Settings**

The settings menu gives access to all adjustable system parameters. To alter a setting, press “Select” on the setting that is to be altered and scroll between the alternatives shown using the arrow keys. Press “Select” to accept the highlighted setting. The following alternatives can be selected in the settings menu:

**Screen saver**, adjusts the delay before the screen saver is activated or turns the function off.

**Language**, selects desired language

**Units**, selects between European, British or American units.

**Volume**, adjusts the speaker volume.

**Brightness**, adjusts the screen brightness.

**Back lighting**, adjusts the screen backlight.

**Keyboard**, selects the keyboard layout.

**System information**, shows the hardware version, software version, serial number, information about tachograph, information about connected USB units and information about connected navigation devices.

Settings	
Screen saver	▼
Language	▼
Units	▼
Volume	▼
Brightness	▼
Backlight	▼
Keyboard	▼
System information	

## System errors and warnings

If a fault occurs, a fault message is shown on the screen. Usually you acknowledge that you have read a fault, warning or message by pressing "Esc". The message will then disappear although the problem will still be present and should be rectified as soon as possible.

### Driver Time Warning pop ups

A "Driver Time Warning" pop up appears showing the rule about to be broken (rule name and remaining time) or already broken (rule followed by "broken" and exceeding time). Supported warnings are:

- Continuous driving time
- Daily driving time
- 1 week driving time
- 2 week driving time
- Daily resting

### Driver Time Information pop ups

- You must make up rest time during the week.
- Normal daily rest is 11 hours. This period was a reduced daily rest period.

### Driver Time Management pop ups

- Was last rest a weekly rest?
- Normal weekly rest is 45 hours. OK to consider this rest period as a weekly rest?

### Tachograph download warning pop ups

A "Driver data warning" pop up appears when no driver data have been successfully transferred to office since a long time (threshold is setup by office):

- Driver data has not been transferred since more than XX days. Proceed now?

A "Tachograph data warning" pop up appears when no tachograph data have been successfully transferred to office since a long time (threshold is setup by office):

- Tachograph data has not been transferred since more than xx days. Proceed now?

## **Tachograph download information pop ups**

- Remote download process is being initiated. Please wait...
- Data transfer is only allowed once a day. Proceed now?
- Transfer ongoing, refer to status menu for further updates.

## **Tachograph download error pop ups**

- No link with office. Please retry later!
- Failed: login with driver card is required to perform data transfer.
- Failed: data has already been transferred today.



## Roof air deflector, setting instructions

The following requirements must be met to obtain correct adjustment and effect from the roof spoiler:

- The truck must be parked on a flat surface.
- The tyres must have the correct tyre pressure.
- Trucks with air suspension must have the correct pressure in the compressed air system.
- The cab hinges must be intact.
- Neither driver or passenger may be inside the cab during adjustment of settings.

### Clarifications

**H** = difference between H1 and H2.

**H1** = height of body. Measurement should be made from the top of the chassis, or from the ground to the top of the body.

**H2** = cab height. Measurement should be made from the top of the chassis (compare H1) and to the upper edge of the rain gutter on the rear of the cab.

**G** = distance between the cab rear side (at rain gutter) and body front side.

**A** = adjustment stay.

**A1** = top hole of stay.

### Calculation example

An FH with long low cab has:

$H1 = 3700, H2 = 2750$

$H = H1 - H2 = 950$

$G = 700$

Enter the values in the diagram for an FH with long low cab and read off. In this case field A4. Therefore use hole A4. If the read-off point approaches the upper border line of the field, choose the next field.

### Note!

If any of the values are changed, a new setting of the spoiler must be made.

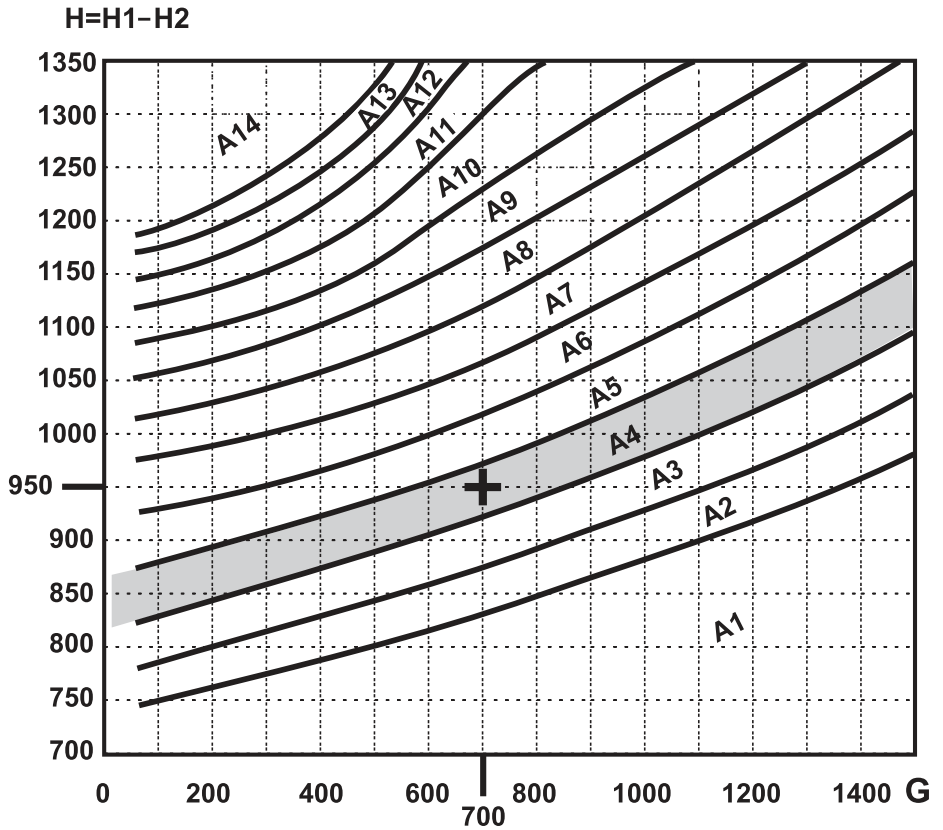

# 472 External equipment

## Short low cab FH

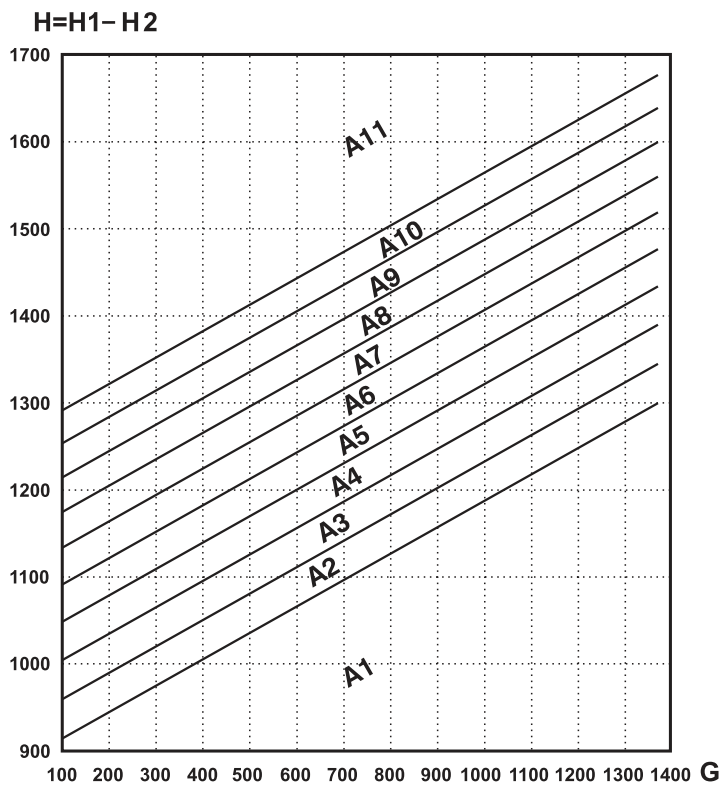
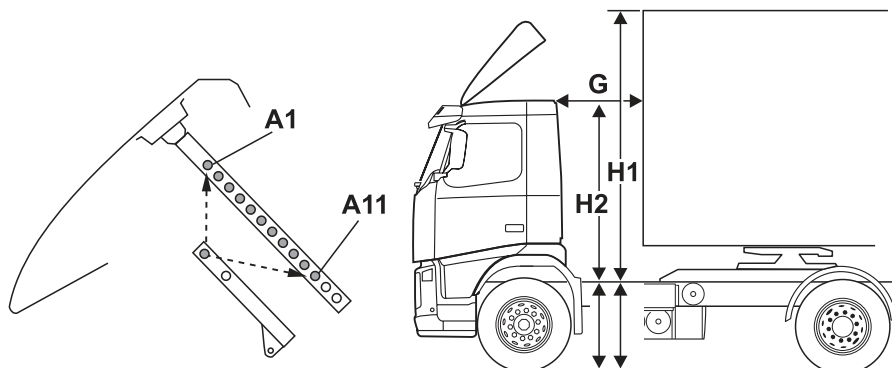

Long low cab FH

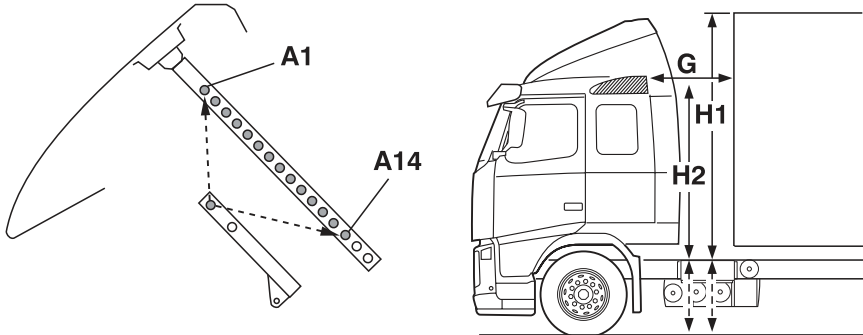

$H = H1 - H2$

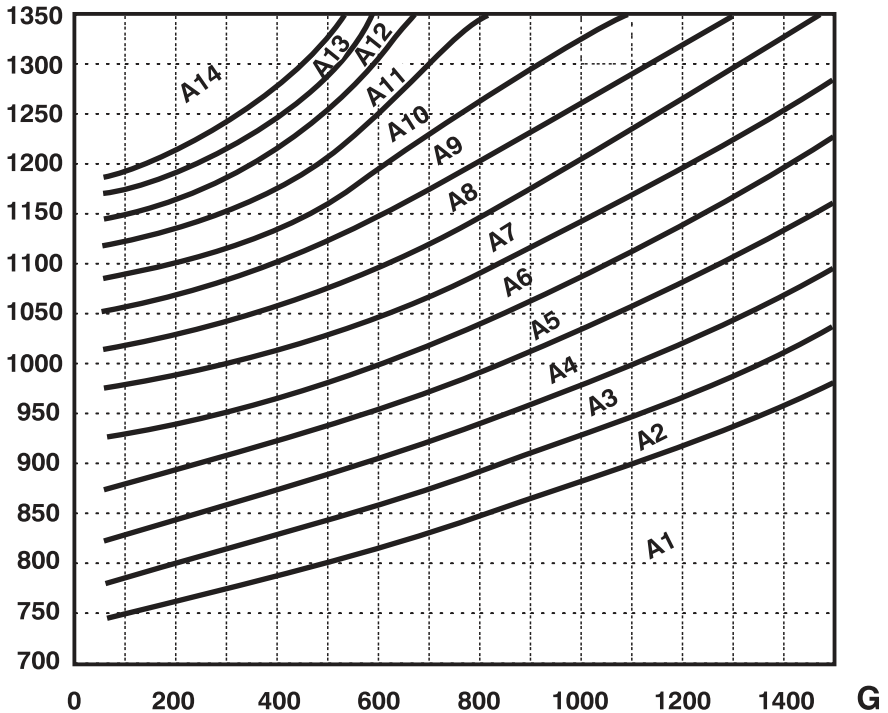

## Globetrotter FH

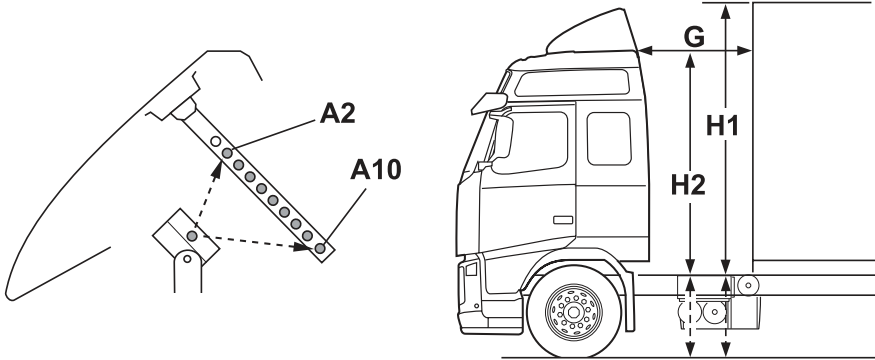

$$H = H1 - H2$$

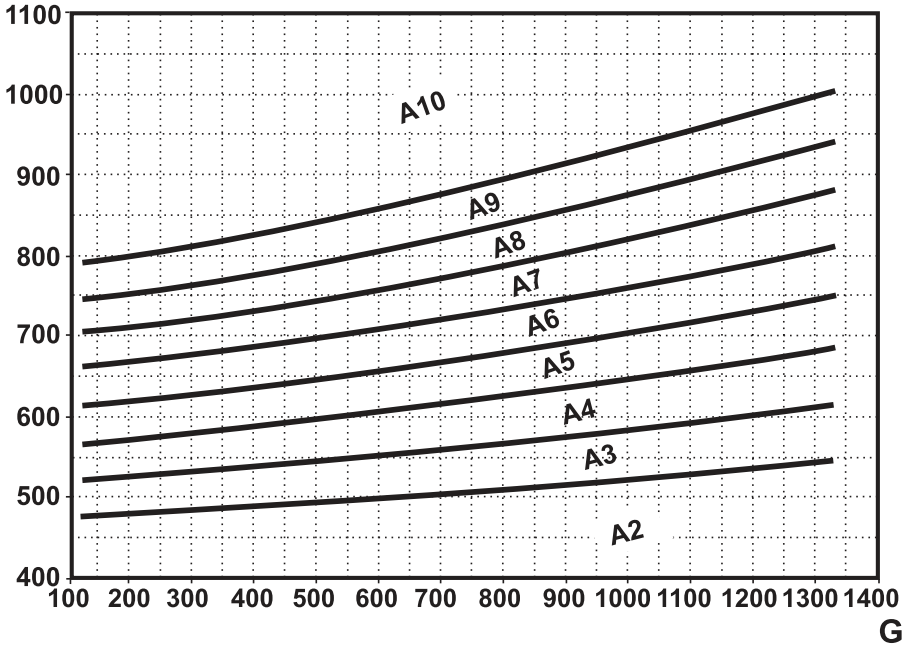

Low roof spoiler

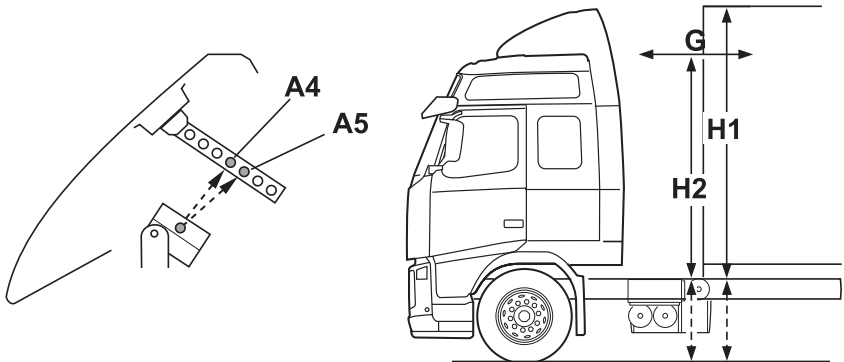

$$H = H1 - H2$$

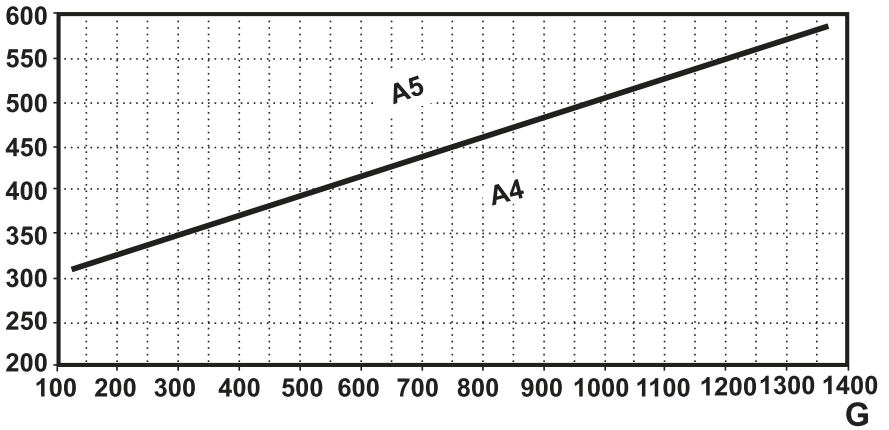

## Roof air deflector, setting instructions

The following requirements must be met to obtain correct adjustment and effect from the roof spoiler:

- The truck must be parked on a flat surface.
- The tyres must have the correct tyre pressure.
- Trucks with air suspension must have the correct pressure in the compressed air system.
- The cab hinges must be intact.
- Neither driver or passenger may be inside the cab during adjustment of settings.

### Clarifications

**H** = difference between H1 and H2.

**H1** = height of body. Measurement should be made from the top of the chassis, or from the ground to the top of the body.

**H2** = cab height. Measurement should be made from the top of the chassis (compare H1) and to the upper edge of the rain gutter on the rear of the cab.

**G** = distance between the cab rear side (at rain gutter) and body front side.

**A** = adjustment stay.

**A1** = top hole of stay.

### Calculation example

An FH with long low cab has:

$$H1 = 3700, H2 = 2750$$

$$H = H1 - H2 = 950$$

$$G = 700$$

Enter the values in the diagram for an FH with long low cab and read off. In this case field A4. Therefore use hole A4. If the read-off point approaches the upper border line of the field, choose the next field.

### Note!

If any of the values are changed, a new setting of the spoiler must be made.

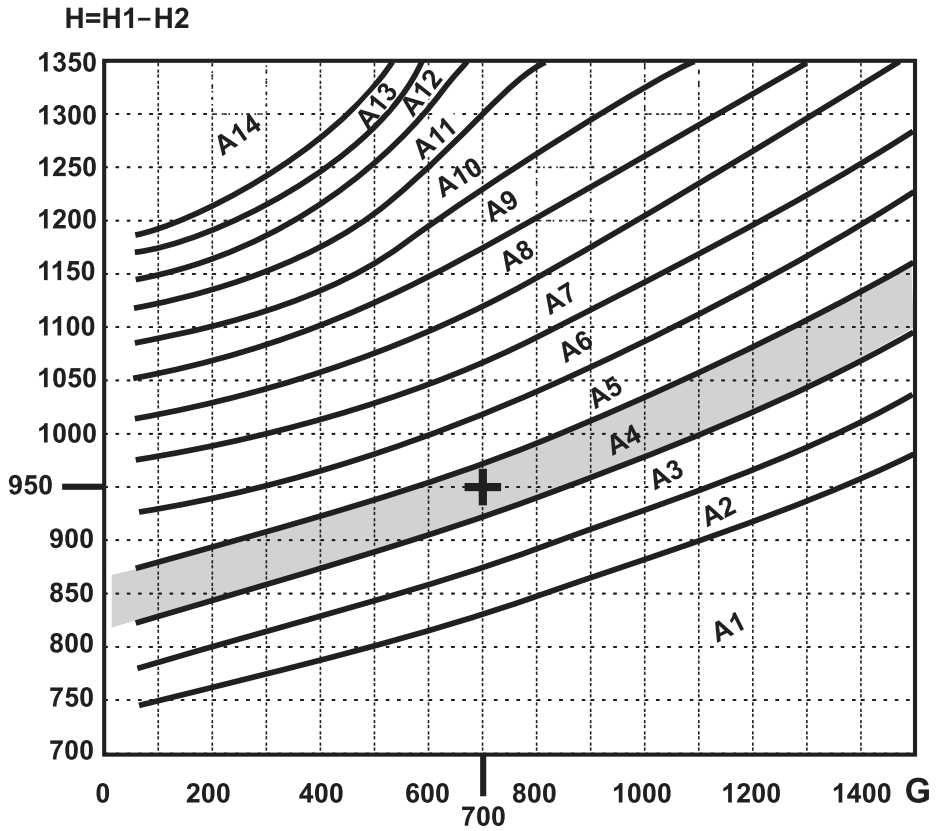



# 478 External equipment

## Globetrotter XL FH

First choose which diagram to use:

A = "With accessory parts"

B = "With supplied upper stay"

C = "Lower stay in normal position"

D = "Lower stay in delivery position"

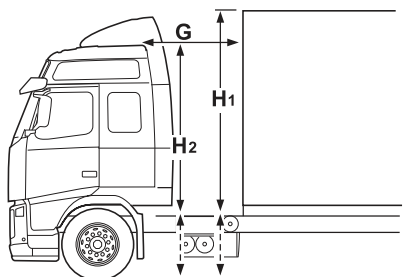

$$H = H1 - H2$$

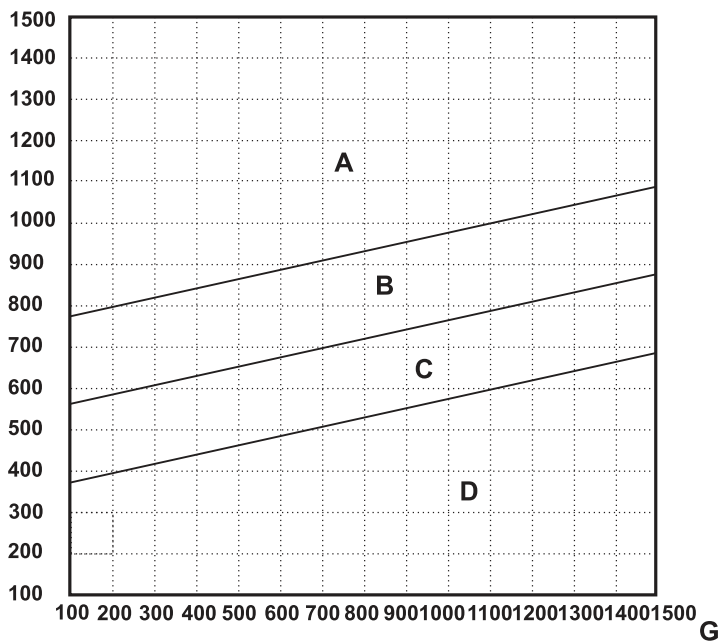

Lower stay in delivery position

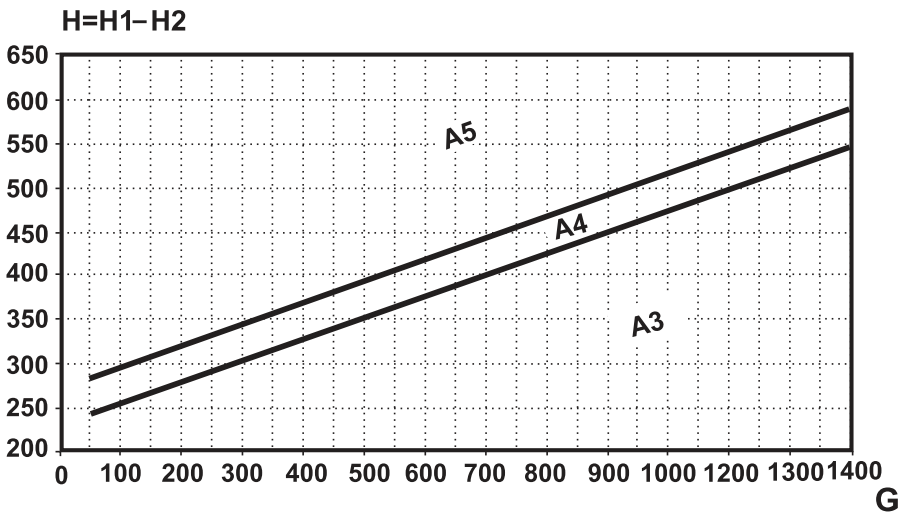
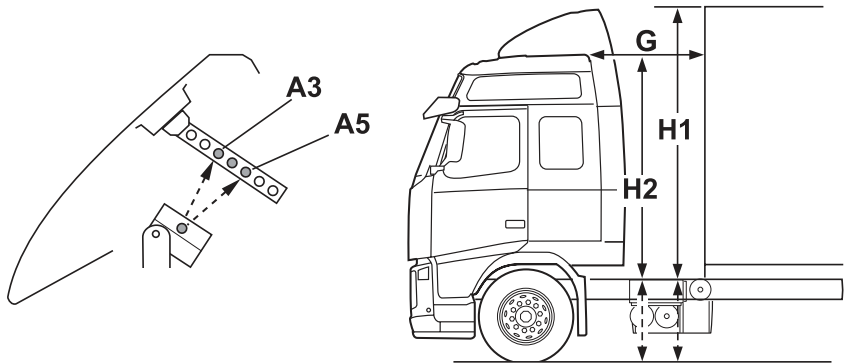

# 480 External equipment

Lower stay in normal position

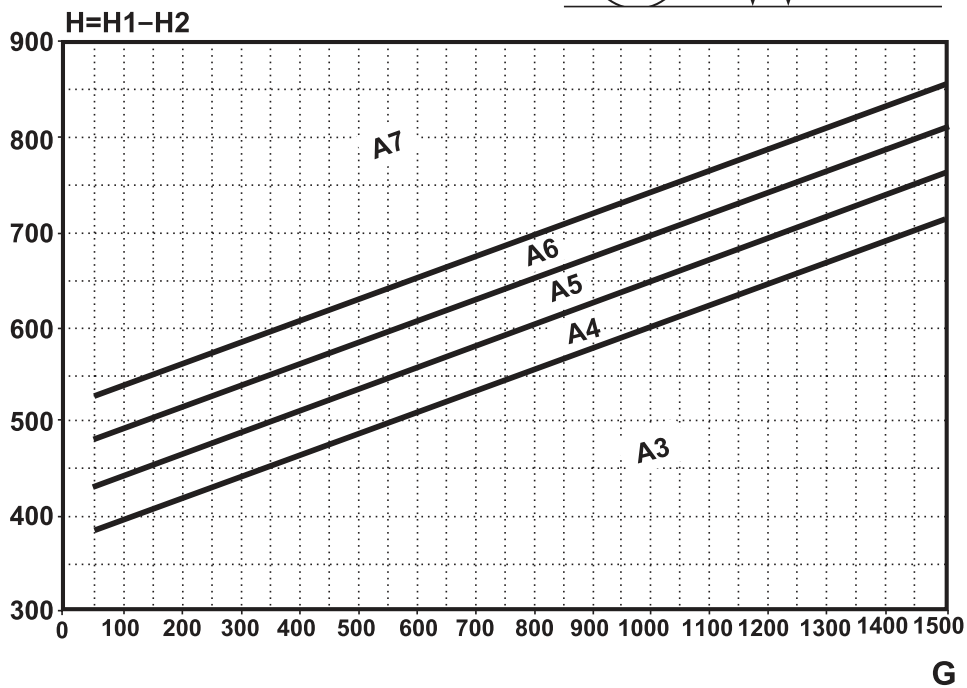
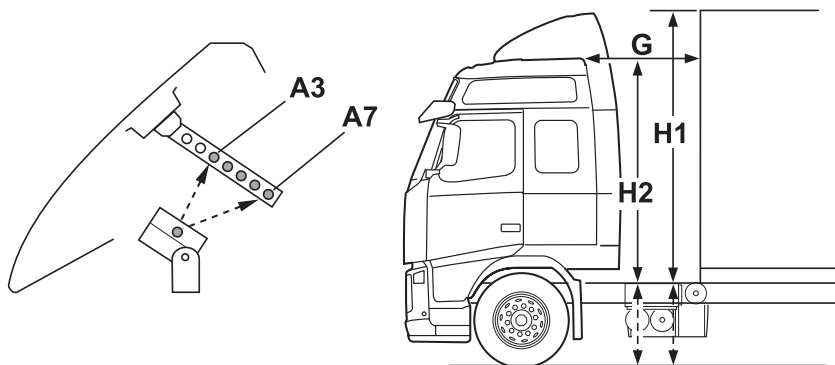

With supplied upper stay

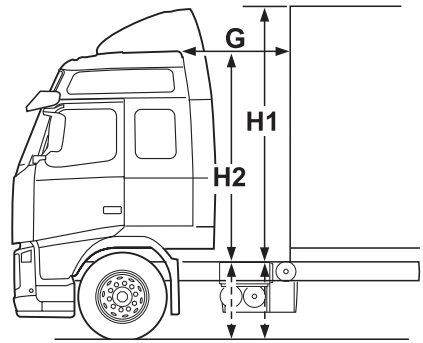
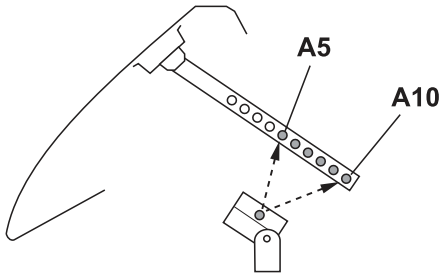

$$H = H1 - H2$$

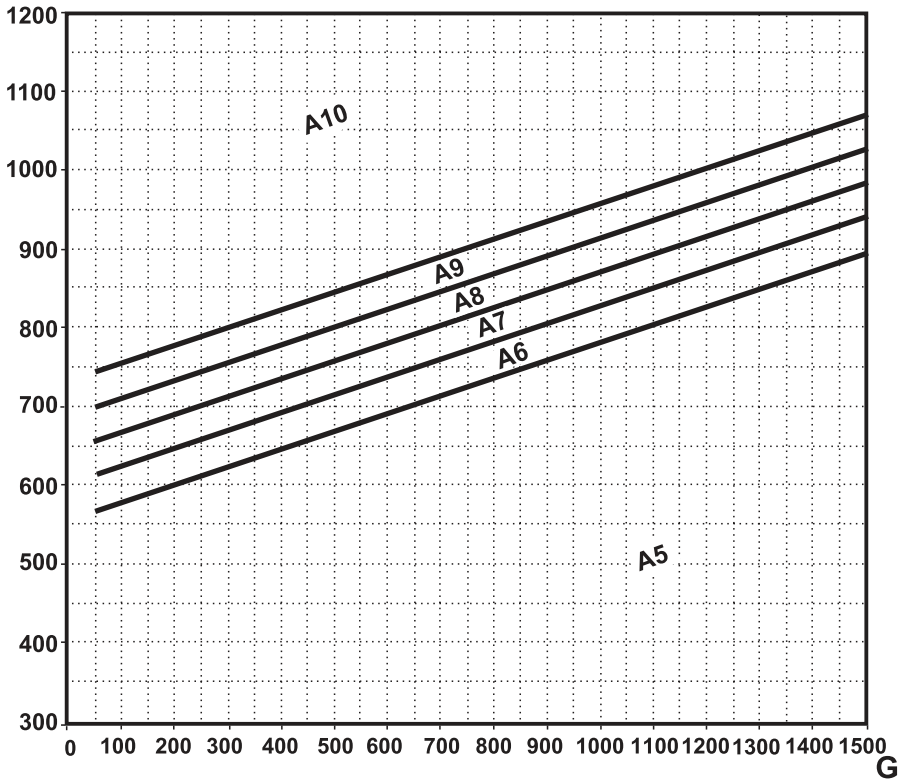

# 482 External equipment

With accessory parts

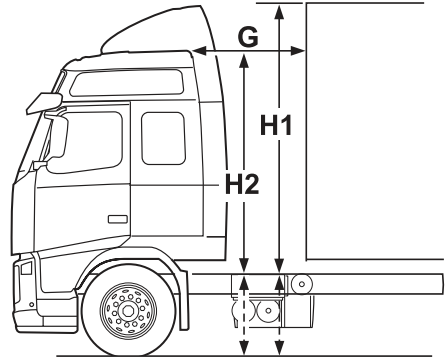
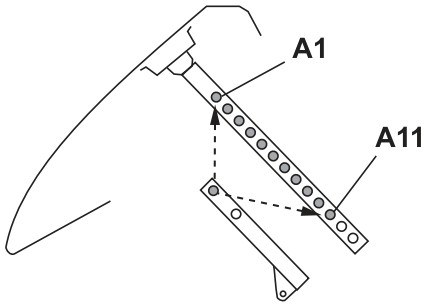

$$H = H1 - H2$$

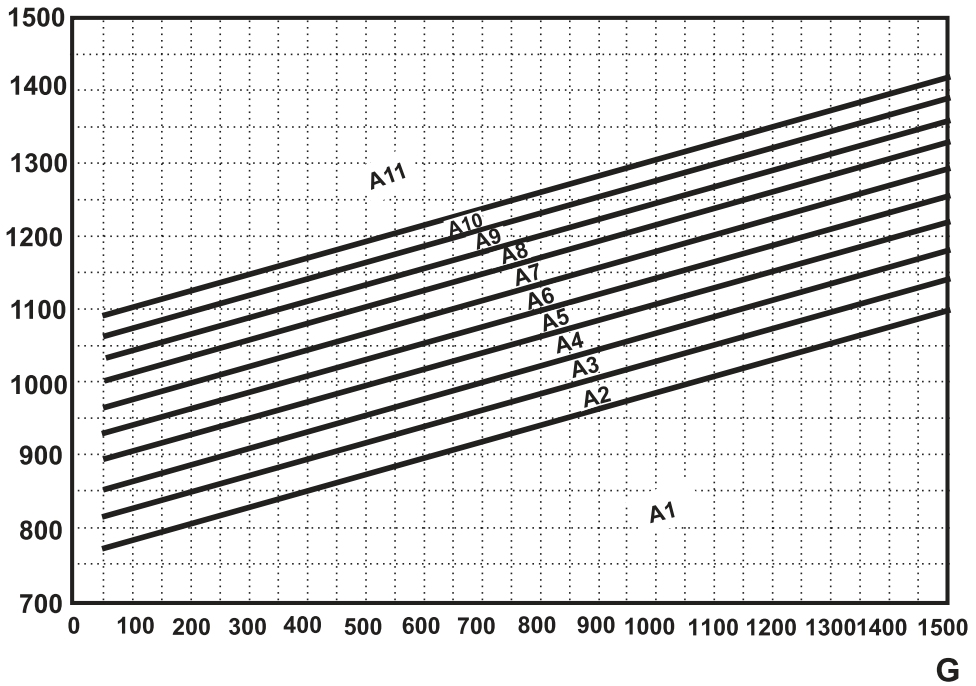

## Roof air deflector, setting instructions

The following requirements must be met to obtain correct adjustment and effect from the roof spoiler:

- The truck must be parked on a flat surface.
- The tyres must have the correct tyre pressure.
- Trucks with air suspension must have the correct pressure in the compressed air system.
- The cab hinges must be intact.
- Neither driver or passenger may be inside the cab during adjustment of settings.

### Clarifications

**H** = difference between H1 and H2.

**H1** = height of body. Measurement should be made from the top of the chassis, or from the ground to the top of the body.

**H2** = cab height. Measurement should be made from the top of the chassis (compare H1) and to the upper edge of the rain gutter on the rear of the cab.

**G** = distance between the cab rear side (at rain gutter) and body front side.

**A** = adjustment stay.

**A1** = top hole of stay.

### Calculation example

An FM with long low cab has:

$H1 = 3700$ ,  $H2 = 2750$

$H = H1 - H2 = 950$

$G = 700$

Enter the values in the diagram for an FM with long low cab and read off. In this case it is field A2.

Therefore use hole A2. If the read-off point approaches the upper border line of the field, choose the next field.

### Note!

If any of the values are changed, a new setting of the spoiler must be made.

# 484 External equipment

$$H=H1 - H2$$

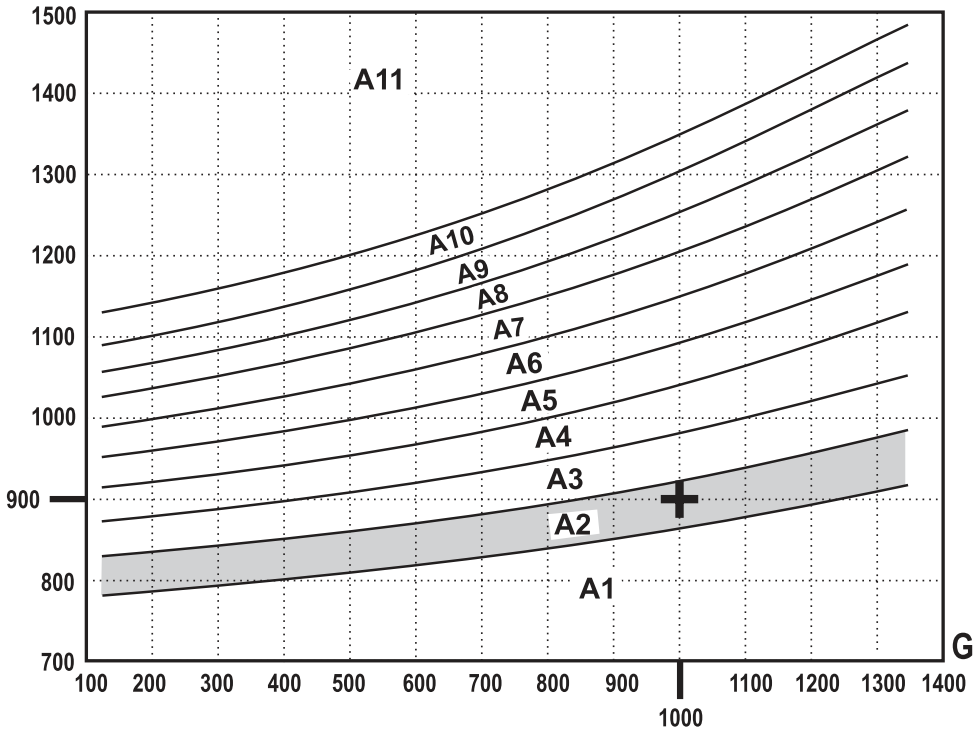

J8010118

Short low cab FM

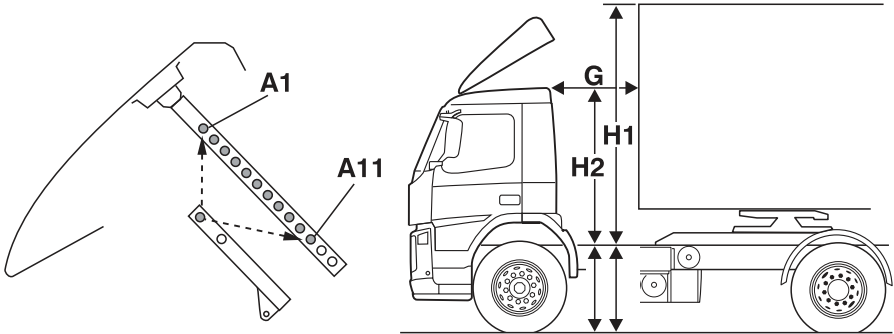

$H = H1 - H2$

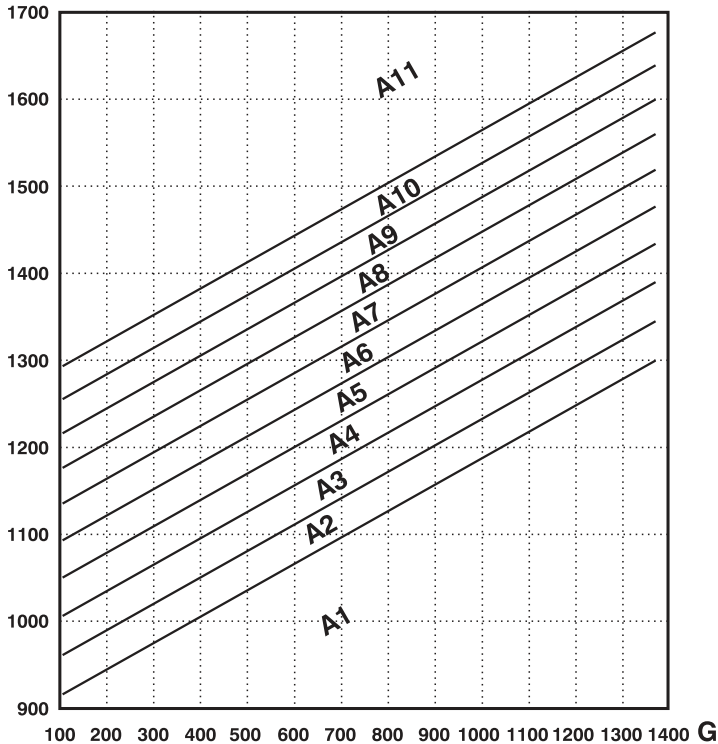



## Long low cab FM

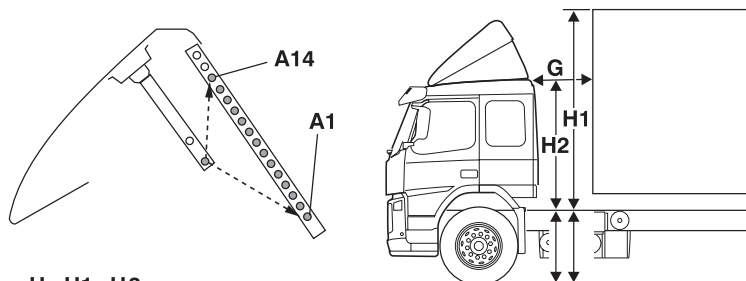

$$H = H1 - H2$$

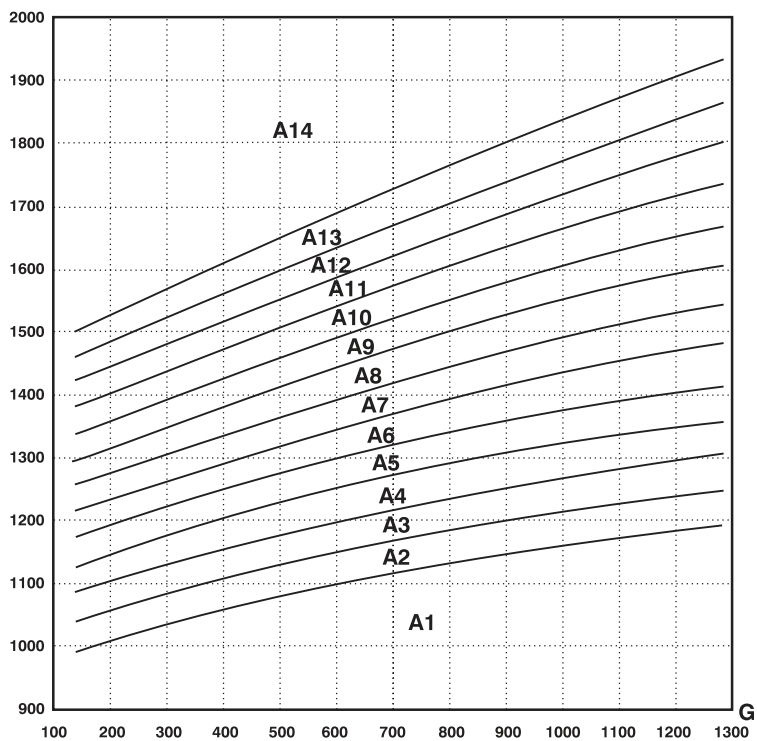

Globetrotter FM

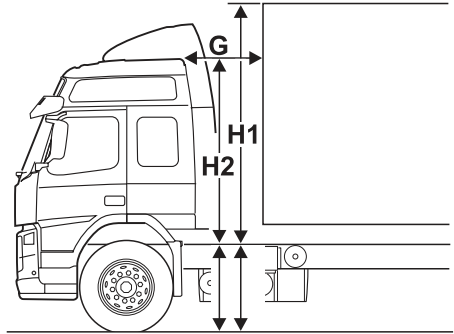
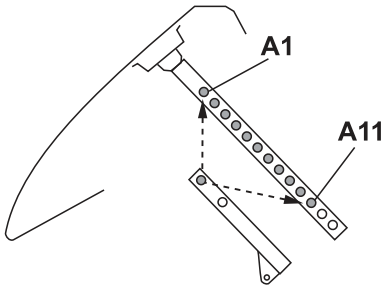

$$H = H1 - H2$$

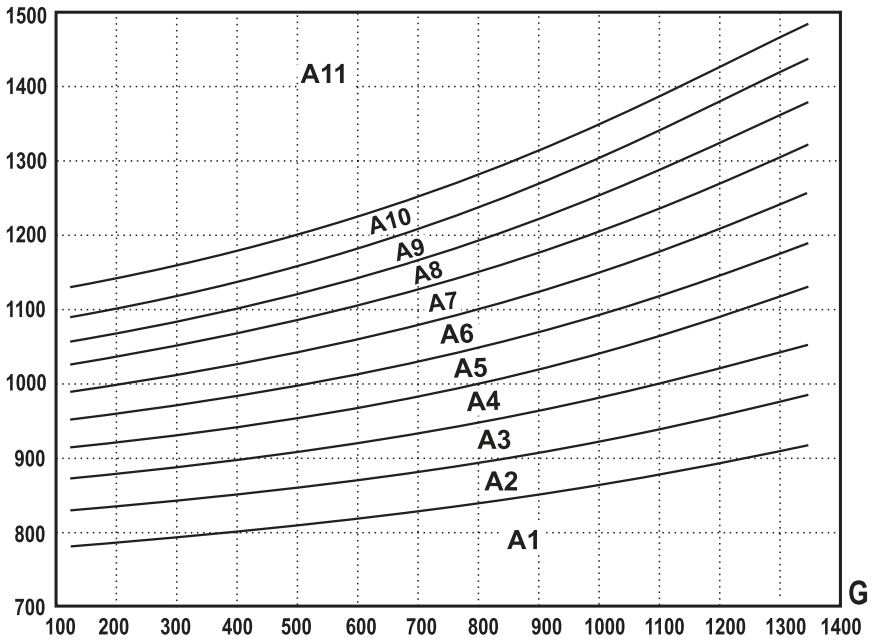

## Globetrotter LXL FM

(Standard)

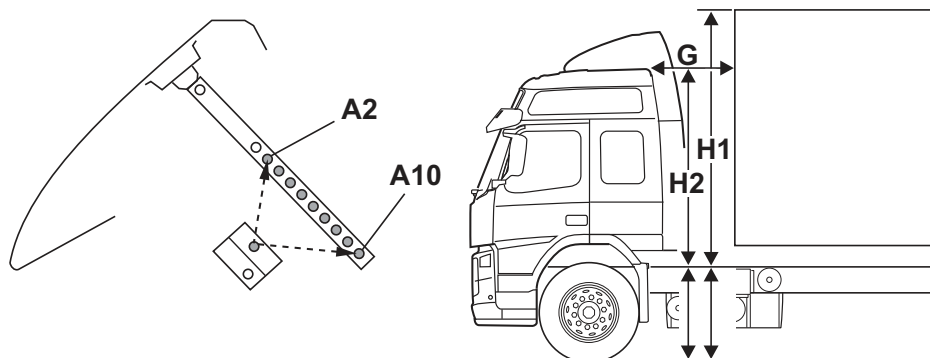

$$H = H1 - H2$$

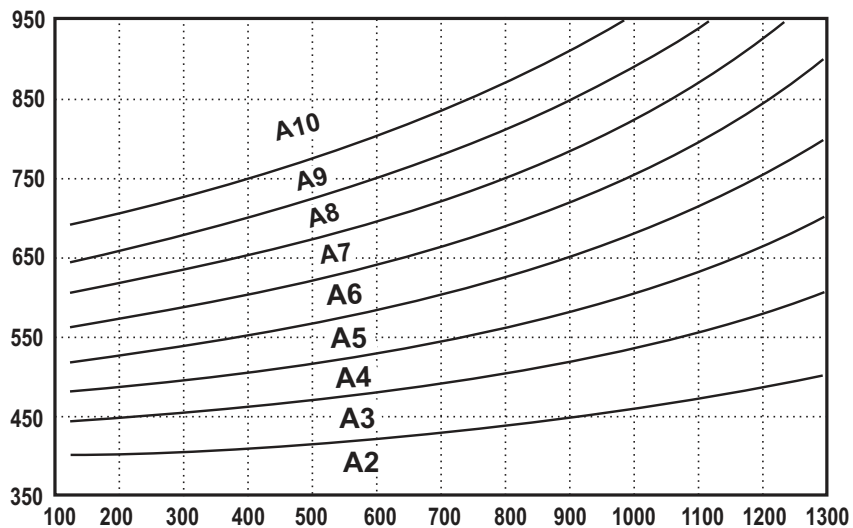

G

(Long stanchions. Only in certain markets.)

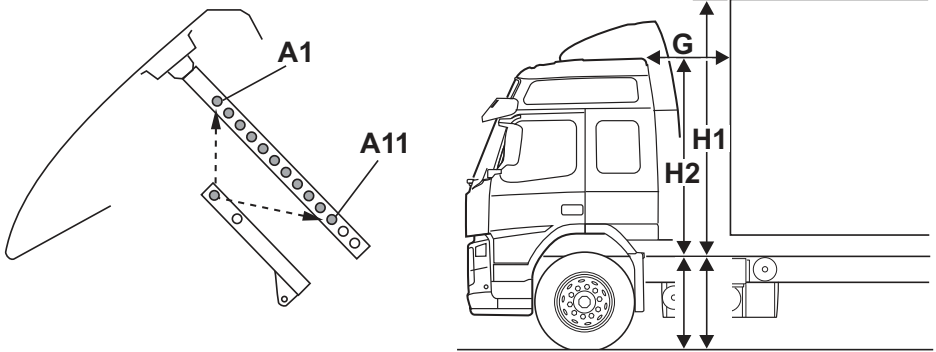

$$H = H1 - H2$$

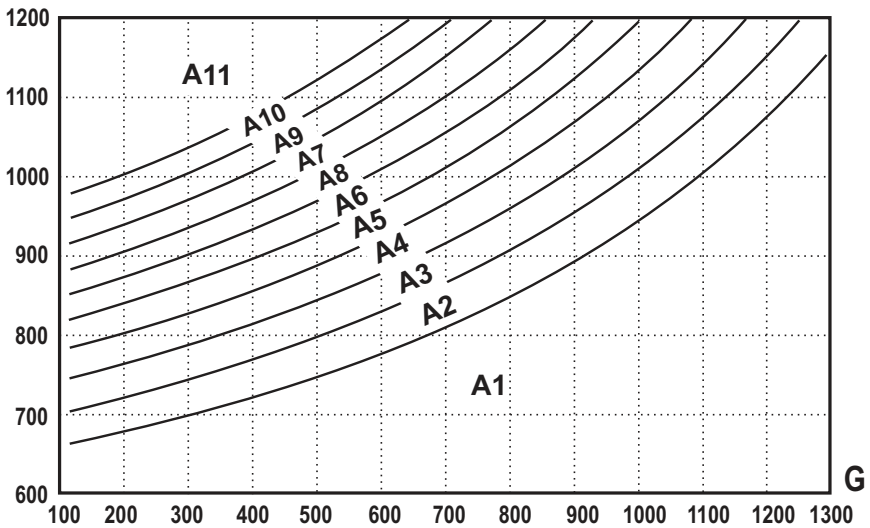

### Front mirror

When machine washing the cab, make sure the front mirror is not damaged. The mirror, sun shade and roof of the cab can be damaged in a machine wash with a front brush. To avoid this, strap the mirror in place to e.g. a handle on the front of the cab.

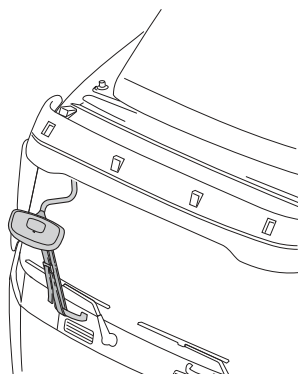
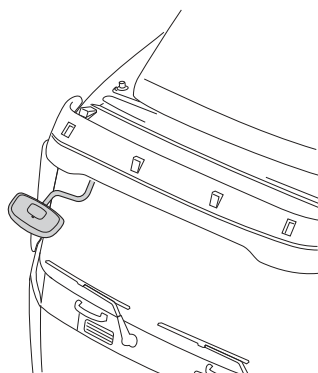

## Ladder

**Important !** Fix the ladder securely.

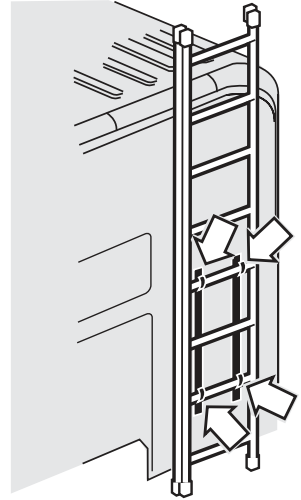

J8008441



J8008440



## Warning!

You should **never** climb on the ladder when it is mounted on the cab.

## Side underrun guard

### Extend the side underrun guard

- 1 Pull up the pins
- 2 Extend the side underrun guard

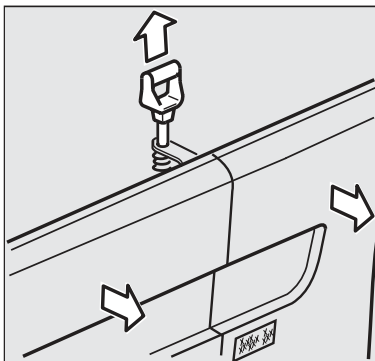

J0010429

### Note!

Do not pull on the side skirt.

## Remove the side underrun guard

- 1 Extend the side underrun guard
- 2 Remove any lamps fitted to the side skirt
- 3 Loosen the wire holding the side underrun guard
- 4 Pull the side underrun guard straight up

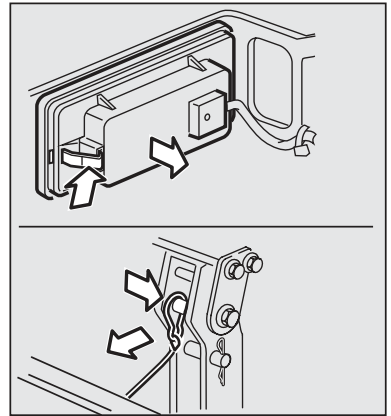

J0010431

### **Note!**

If the truck is to be driven without the side underrun guard, remove the rear bracket as well.

## Install the side underrun guard

Check that:

- the guard fits down into the lower groove properly
- the wires are in place
- the locking pins fit into the holes correctly



### Lower the spare wheel

First check that the tensioning strap

- is mounted
- is intact, including the seams
- has a knot in the roller
- is properly coiled on the roller
- tighten the strap if required

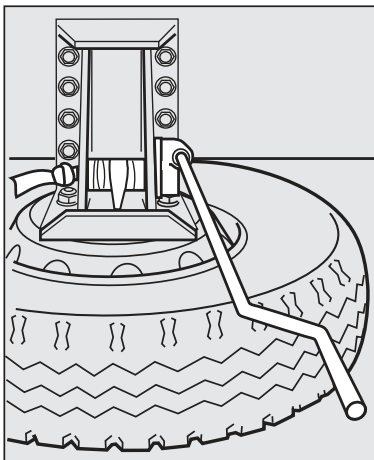

J0010180

Stand outside the wheel's radius.

Loosen all four nuts.

A sleeve for loosening the nuts and a crank for lowering the wheel are in the vehicle's tool equipment.

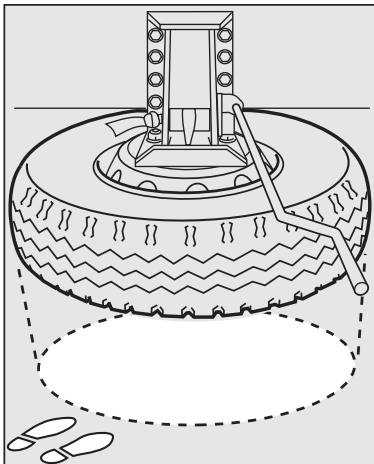

J0010182

## Raise the spare wheel

First check that the tensioning band

- is mounted
- is complete, including the seam
- has a knot in the roller
- is properly coiled on the roller

Tighten the band if necessary.

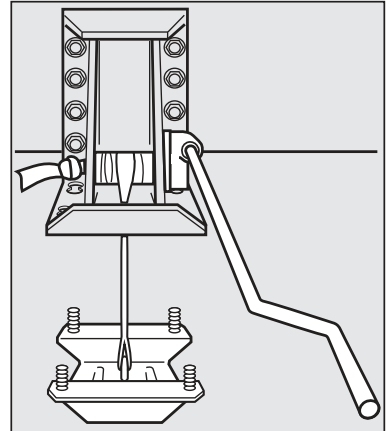

J0010181

If the vehicle has a side underrun guard or chassis skirt, use the inner hole (A) on the holder.

Lay the wheel straight under the holder. Do not pull it in with the winch.

Tighten all four nuts to 400 Nm.

A crank for lifting up the wheel, and sleeve for tightening the nuts are in the vehicle's tool equipment.

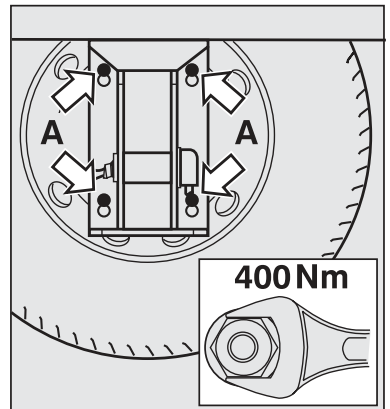

J0010183

## Spare wheel retainer behind the cab

The spare wheel retainer is mounted behind the cab and the spare wheel is winched down on the right-hand side of the truck.

In the event of a puncture, try to park the truck on level, solid ground, leaving sufficient space to be able to winch down the wheel.

Take care not to slip when standing on the chassis frame.

- 1 Tubular stay
- 2 Attachment cross
- 3 Winch
- 4 Strap
- 5 Attachment bar
- 6 Clevis pin and split pin

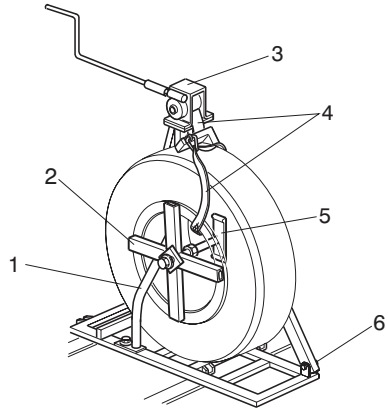

Check that the strap is undamaged and that the stitching is not broken.

Check the knot in the winch roller.

Check the clevis pin and split pin which holds the lever.

Check that the strap does not lie in the split in the rim or has fastened round the air valve.

Check that the strap is correctly wound onto the winch. Tension the strap if necessary. The crank is included in the truck tool kit.

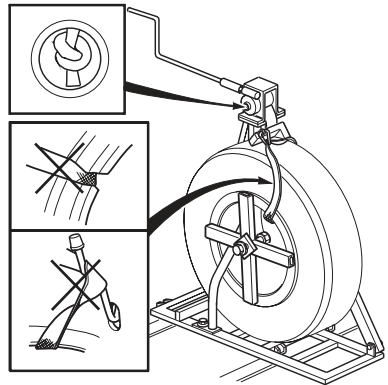

- 1 Unscrew the M20 bolt on the attachment cross approx. 15 mm.  
Turn the attachment bar 90° and pass it between the spare wheel retainer stays.

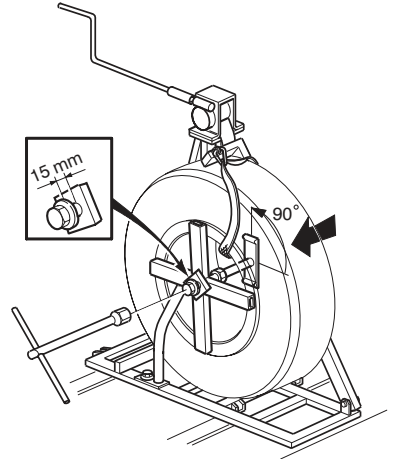

 **Caution!**

Hold the socket and T-bar at right angles to the bolt to avoid it slipping and causing possible injury.

 **Caution!**

The wheel may move, depending on the angle of the parked truck. Take care that hands etc are not trapped.

# 498 External equipment

- 2 Remove the three M10 bolts which hold the tubular stay. Remove the stay.

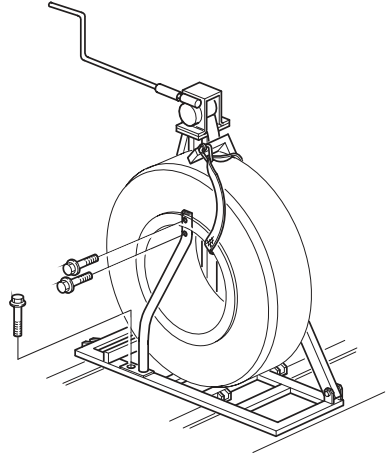

- 3 Unwind the strap on the winch so that the wheel can be rolled out to the edge of the retainer. The strap should be stretched in this position. Check that the wheel can be winched down to the ground without any risk of passing traffic.

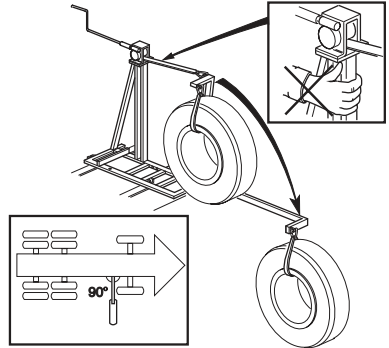

## **Caution!**

Avoid holding a hand on the upper edge of the retainer (under the winch) as there is a risk of fingers being trapped by the lever.

- 4 Winch the wheel down to the ground. Remove the support strap.

## Winching up and securing the wheel

Place the support strap round the wheel.

Carry out similar function checks to those prior to lowering the wheel.

Place the wheel at right angles to the truck direction of travel.

Winch up the wheel until it rests steadily on the retainer.

Do not remove the support strap from the wheel.

Move the wheel into position. Make sure that the complete wheel stands upright against the spare wheel retainer stays. Wind in the strap.

Fit the attachment bar and attachment cross against the retractor and rim.

Check that the lugs that hold the attachment bar in place are outside the spare wheel retainer stays.

Torque-tighten the bolt to  $80 \pm 20$  Nm.

Fit the tubular stay to the spare wheel retainer.

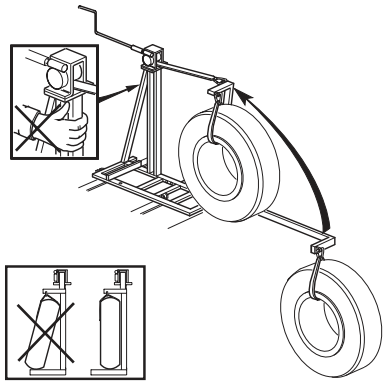

### **Caution!**

Avoid holding a hand on the upper edge of the retainer (under the winch) as there is a risk of fingers being trapped by the lever.

## Turntable, general advice

Volvo use turntables from several different manufacturers. An instruction for the turntable is attached to the turntable handle when the truck is supplied from the factory. If the instructions are missing, contact your Volvo dealer who can help you get hold of a new instruction. Follow the general advice in this instruction until you receive the instructions from the supplier.

### **Note!**

Only use the general instructions until you receive the instructions from the supplier.

## Operation

Turntables can have somewhat different designs, depending on the manufacturer. A common feature is that all have a handle for releasing the trailer coupling and a safety inhibitor to prevent the handle from accidentally releasing the coupling. Make sure that the handle is secured by the inhibitor before driving away.

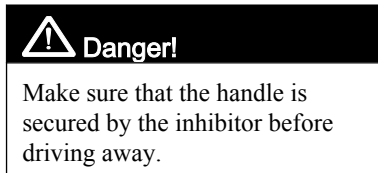

## Care

Turntables made from steel plate or with surfaces of another metallic material shall be greased before the first coupling. The surface shall be completely covered in grease and more grease shall be added if the metal surface becomes visible. Follow the advice in the suppliers instructions when you receive them. The turntable requires a lithium-based grease with NLGI 2 consistency, e.g. Volvo grease 2 EP.

## Couple the trailer

On trucks with the battery box at the rear it is especially important to follow these instructions when coupling or uncoupling a trailer.

## Couple a trailer

- 1 Position the tractor and trailer on a level, even surface.
- 2 Make sure the trailer cannot roll.
- 3 Unlock the fifth wheel.
- 4 Make sure the trailer's slide plate is 20–50 mm lower than the truck's fifth wheel. See the illustration on the right.
- 5 Reverse the truck.
- 6 Make sure the fifth wheel is properly locked, and to check, jerk the truck forward just once.
- 7 Fold up the support legs.
- 8 Connect the air and electricity supplies.

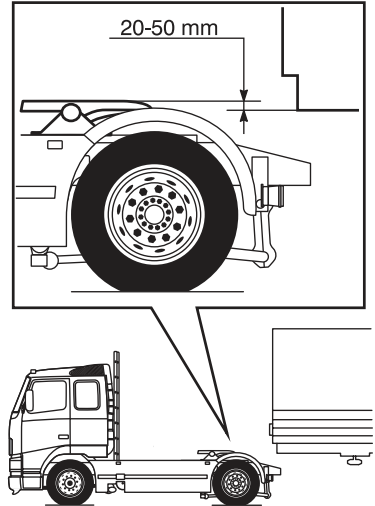

J9008577



## 502 External equipment

### Uncoupling a trailer

- 1 Position the tractor and trailer on a level, even surface.
- 2 Make sure the trailer cannot roll.
- 3 Lower the support legs to the correct position.
- 4 Lower the truck's rear air suspension so that a space of 20–50 mm is created between the fifth wheel and the trailer sliding plate. See the illustration on the right.
- 5 Disconnect the air and electricity supplies.
- 6 Unlock the fifth wheel.

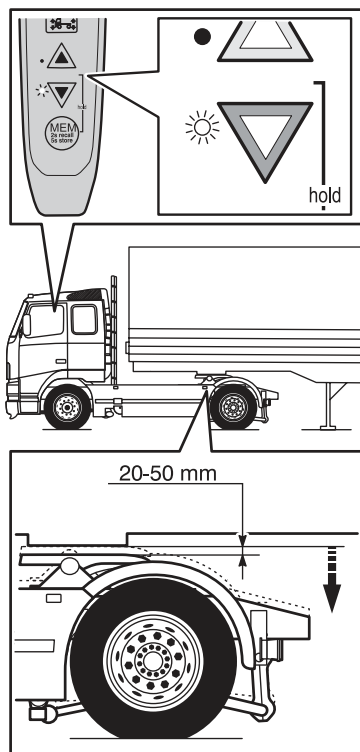

J9008576

### Moving the turntable

- 1 Release the inhibitor with the switch in the cab
- 2 Keep the trailer stationary with the trailer brake
- 3 Move the truck carefully



J9008326



Make sure that there is no one between the tractor and the trailer before you move the turntable.

## General information

Driver instruction Maintenance contains information about preventive measures that the driver should take in order for the truck to be used in traffic in a safe way with maximum reliability. The maintenance in this instruction is however not totally inclusive. Many more points are included in the service provided by Volvo's workshops.

When a truck is purchased, a maintenance program is created. The program is based on vehicle type, driving conditions, oil grades, etc and is unique for every truck. If the conditions that applied when the maintenance program was created should change, the maintenance program must also be changed. Contact your Volvo dealer.

For complete information about lubrication points, oils and fluids, service intervals, Basic service and Full service, refer to Volvo's service literature which can be ordered from your Volvo dealer together with Volvo's complete assortment of lubricants.

## Checks before driving

These points are included in the daily inspection. See "Driver service" in the folder's plastic sleeve for the check list.

- Apply the parking brake
- Switch on the lighting
- Turn on the hazard warning lights

**1** Control and warning lamps on the instrument panel shall work

**2** Headlights and other lighting shall function

**3** There shall not be any stones in the tyres

4 There shall not be any condensation in the air tanks

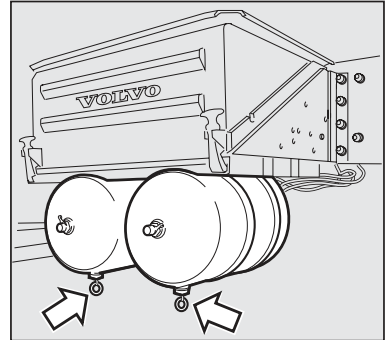

Drain the air tanks to check that there is no condensation water. Water in the air tanks is a sign that the air drier is not functioning.

5 There shall not be water in the fuel water-separator, if such is fitted. The symbol for water-in-fuel shall not light in the display. If the symbol should light, the water separator must be drained

6 Windscreens and rear view mirrors shall be whole and clean

7 The trailer coupling shall be in good condition

8 The load shall be properly secured

9 The coolant level

The coolant level with a cold engine shall lie between the MIN and MAX marks on the expansion tank. Fill with coolant, Volvo recommend ready-mixed Volvo Coolant VCS. If there is good quality water available, concentrated Volvo Coolant VCS mixed with water can be used instead.

**Always use Volvo Coolant VCS**, which contains an anti-corrosion agent especially adapted to suit Volvo engines. Mixing with other types of coolant can result in inferior anti-corrosive properties resulting in damage to the engine.

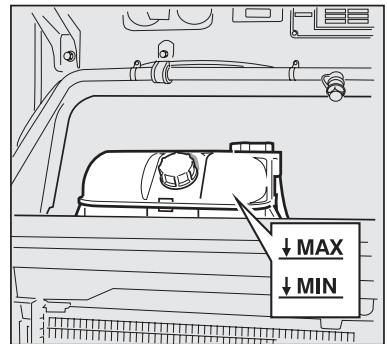

## 9 The coolant level

The coolant level with a cold engine shall lie between the MIN and MAX marks on the expansion tank. Fill with coolant, Volvo recommend ready-mixed Volvo Coolant VCS. If there is good quality water available, concentrated Volvo Coolant VCS mixed with water can be used instead.

**Always use Volvo Coolant VCS**, which contains an anti-corrosion agent especially adapted to suit Volvo engines. Mixing with other types of coolant can result in inferior anti-corrosive properties resulting in damage to the engine.

### **Note!**

Never mix Volvo Coolant VCS with other coolants or anti-corrosive agents. This could damage the engine.

Make sure the filler and pressure caps are tightened securely by hand.

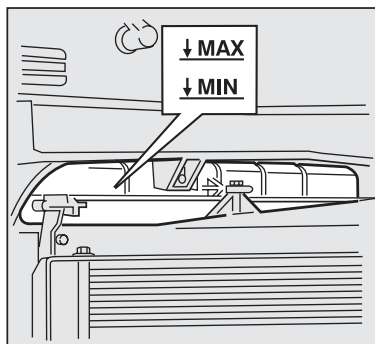

J2017422

Tilt the cab for filling.

### **Note!**

Never mix Volvo Coolant VCS with other coolants or anti-corrosive agents. This could damage the engine.

Make sure the filler and pressure caps are tightened securely by hand.

## 10 Engine oil level

The dipstick is secured. Bend the dipstick slightly downwards and then pull it out. Make sure the dipstick is secured again after checking the oil level.

The distance between markings on the dipstick corresponds to 6-8 litres of oil depending on the version.

The oil level can also be checked on the driver information display.

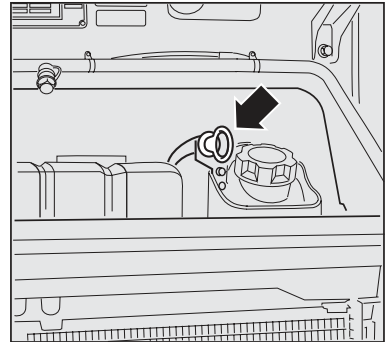

J2017384

### Note!

The level must never drop below the bottom mark! Top up with oil when the level approaches the bottom mark. **Do not overfill!**

On a run-in engine, the normal oil level is between the min and max marks on the dipstick.

## 10 Engine oil level

The dipstick is secured. Bend the dipstick slightly downwards and then pull it out. Make sure the dipstick is secured again after checking the oil level.

The distance between markings on the dipstick corresponds to 6-8 litres of oil depending on the version.

The oil level can also be checked on the driver information display.

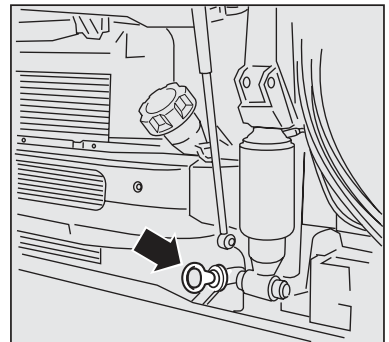

J2017385

## 11 Washer fluid level

The washer fluid tank serves both the headlight and windscreen washers. The tank holds 15 litres of washer fluid. Use Volvo washer fluid, available from Volvo dealers. Follow the directions on the package.

12 Instruments shall be complete and there shall be no cracks in the glass

13 All controls shall be complete and easily operated

14 No faults shall be active in the driver display

15 No faults shall be active on the tachograph

16 The brake pressure shall be sufficiently high

## Checks when fuelling

Always fill up the tank! (Double tanks, connected to each other, should be filled up separately.) Fill up the tank(s) after the days work to avoid condensation in the fuel tanks, due to temperature variations.

### Note!

The level must never drop below the bottom mark! Top up with oil when the level approaches the bottom mark. **Do not overfill!**

On a run-in engine, the normal oil level is between the min and max marks on the dipstick.

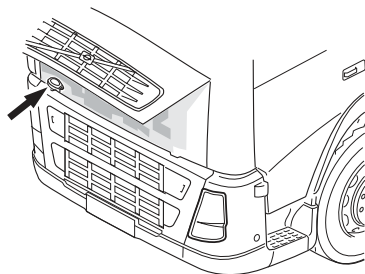

J1007366

The washer liquid tank is under the service hatch.

## 1 Clutch fluid level

Check that the fluid level is between the min and max marks. Top up with fluid as necessary. Dirty or incorrect fluid may cause serious faults.

Fill up with the correct clutch fluid: Brake fluid as per standard DOT 4 (SAE J 1703)



J0008165

### Note!

Fill the fluid carefully. Tighten the reservoir cap well. Any fluid that runs out can damage the paintwork.

## 2 Tyre pressure (at least every fortnight)

For tyre pressures, refer to “Recommended tyre pressures”

## Changing wiper blades

- 1 Lift the wipers off the windscreen.
- 2 Press in the plastic catch (1).
- 3 Push the wipers away from the wiper arm (2). Push down the washer nozzle if it is in the way.

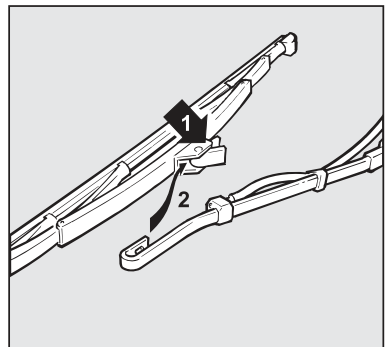

J0008264



## Replace the battery in the remote control

The remote control for the central locking system and possibly an alarm uses a 3 volt battery, type CR 2032.

Replace the battery once a year.

Batteries can be purchased at your local Volvo dealer.

Old batteries should be left for recycling.

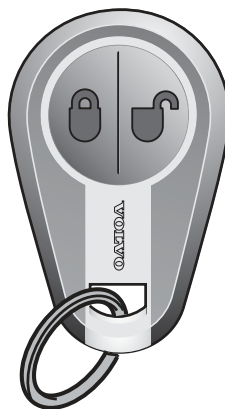

J8010734

## Changing bulbs

### Headlights

- 1 Switch off the main electrical supply.
- 2 Open the door.
- 3 Open the hatch by the upper foot step.
- 4 Pull the locking tab towards you and press in the clips in the hatch (so that the headlamp releases).
- 5 Tilt the headlamp forward.
- 6 Release the cabling.
- 7 Remove the headlamp.
- 8 Fit the new headlamp and refit the other parts.

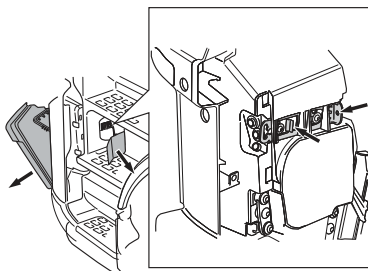

J206384

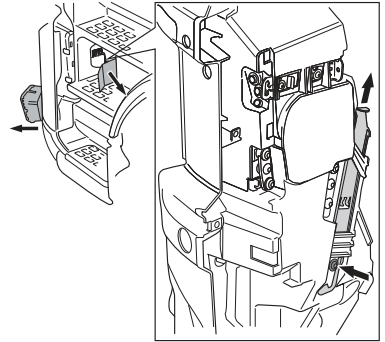

J200364

**Note!**

Never touch the new bulb with your fingers. Grease, oil and the like evaporate from the heat of the bulb and can damage the reflector. This applies especially to headlamp bulbs.

**Note!**

Never wash a truck when the headlamps are tilted forward!

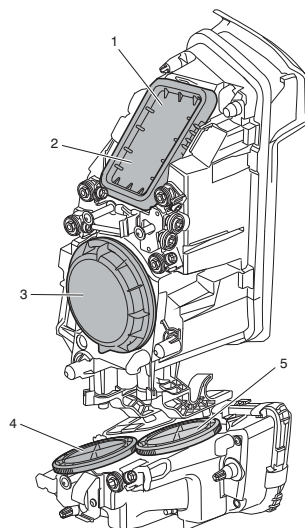

J201644

Number	Function	Watts (W)	Base
1	Direction indicators	21	BAu 15 s
2	Main beam	70	H7 PX 26 d
3	Dipped beam Alternative dipped beam	70 Gas discharge HID	H7 PX 26 d
4	Fog light	70	H3
5	Static Corner Light	70	H7 PX 26 d

## Replace gas-discharge tube

- 1 Open the door.
- 2 Open the hatch by the upper foot step.
- 3 Pull the locking tab towards you and press in the clips in the hatch (so that the headlamp releases).
- 4 Tilt the headlamp forward.
- 5 Loosen the cover over the gas discharge lamp and remove it.



### Caution!

Turn off the lighting, turn off the ignition, remove the key from the ignition lock and disconnect the main power.

- 6 Turn the connector and release the wiring.
- 7 Untighten the clamp that holds the gas discharge lamp and remove the lamp.
- 8 Fit the new gas discharge lamp and clamp it securely.
- 9 Turn the connector to secure it, and fit the cabling.
- 10 Fit the cover over the gas discharge lamp
- 11 Move the headlamp back into place.

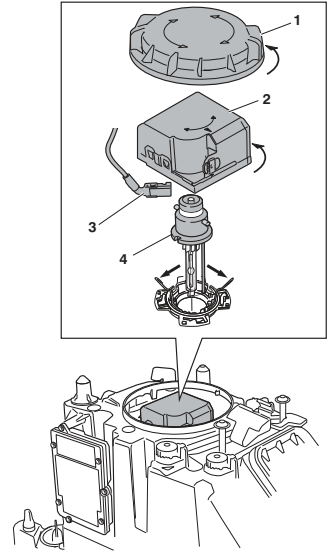

J201684

### **Note!**

Gas discharge lamps contain mercury and must not be thrown away with garbage. Gas discharge lamps must be left for recycling.

### **Note!**

To not touch the glass of the gas discharge lamp. Grease, oil and the like evaporate from the heat of the bulb and can damage the reflector.

### **Note!**

Change both lamps on the same occasion! This is to prevent the lamps from having different tints.

 **Caution!**

Be careful when handling broken gas discharge lamps as they contain mercury, which can be dangerous. Wear gloves, breathing mask and provide good ventilation when replacing lamps with broken casings.

## Rear lights

- 1 Remove the screws securing the lens
- 2 Press the old bulb inwards and turn anticlockwise
- 3 Press in the new bulb and turn clockwise
- 4 Fit the lens

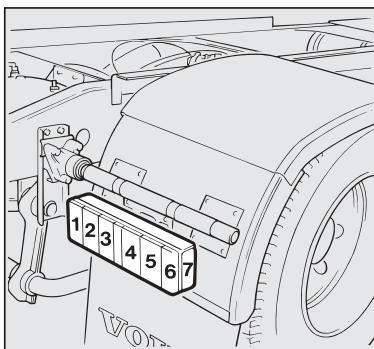

J0008265

Number	Function	Watts (W)	Base
1	Reversing light	21	BA 15 s
2	Rear fog lamp (certain markets)	21	BA 15 s
3	Tail lamp and number plate lighting	5	BA 15 s
4	Brake lights	21	BA 15 s
5	Flashers	21	BA 15 s
6	Tail lights	5	BA 15 s
7	Side marker lamps	5	BA 15 s

- 1 Remove the screws securing the lens
- 2 Press the old bulb inwards and turn anticlockwise
- 3 Press in the new bulb and turn clockwise
- 4 Fit the lens

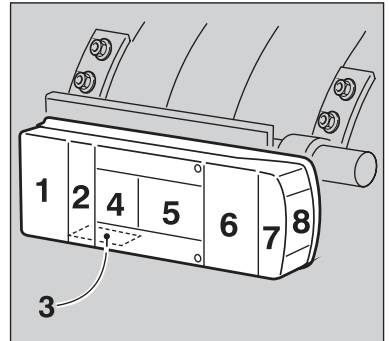

J0010818

Number	Function	Watts (W)	Base
1	Rear fog lamp (certain markets)	21	BA 15 s
2	Tail lights	5	BA 15 s
3	Number plate lighting	5	BA 15 s
4	Reversing light	21	BA 15 s
5	Flashers	21	BA 15 s
6	Brake lights	21	BA 15 s
7	Tail lights	5	BA 15 s
8	Side marker lamps	5	BA 15 s

## Other lighting

### Changing the direction indicator bulbs.

- 1 Remove the screw from bottom of the lens
- 2 Remove the lens
- 3 Press the old bulb inwards and turn anticlockwise
- 4 Press in the new bulb and turn clockwise
- 5 Replace the lens and the screw

# 516 Maintenance

---

Replacement bulbs		Watts (W)	Base
Side flashers		21	BAY 9 s
Position marking lights		5	BA 15 s
Courtesy lamp,	above the bed	10	BA 15 s
	Courtesy lamp, general lighting	10	BA 15 s
	roof, "spot" lamps	10	BA 15 s
	doors	5	BA 15 s
Cigarette lighter illumination		1,2	E15
Ashtray illumination		2	E20

## Engine wash

Use hot water when washing the engine and use a high-pressure washer with caution. Avoid flushing water on electrical components.

## Washing the chassis

The chassis should, as well as the cab, be washed as soon as it has become dirty. Be especially careful, when washing with high pressure, of axles, joints and other moving parts where water and dirt can be forced in. Avoid flushing away any lubrication. If this should happen, be extra careful to re-lubricate the components.

### **Note!**

Never flush water directly on sealings/gaskets.

## Wash the cab

The vehicle should be washed as soon as it becomes dirty, especially during the winter when road salt and dampness otherwise cause corrosion.

To avoid paint damage and to achieve good results when washing, the following should be paid attention to:

Washing method: Use a high pressure washer if available. For dirt that cannot be removed with this

method, you could try to remove carefully with a brush or sponge and with cleaning agents of the type that is best suitable for the particular type of dirt. You risk scratching the paintwork using brush washers without first carefully washing with a high-pressure washer or by using brush washers that are badly maintained (worn, dirty brushes etc.)

**Washing agents, general:** Different cleaning agents are recommended for different types of dirt. Always follow the manufacturer's recommendations with regard to area of use, dosage and maximum temperature. Avoid allowing chemicals to dry on the paintwork.

**Cleaning agents:** Avoid using strong alkaline agents (pH >12). Do not wash the vehicle in direct sunlight. Flush generously with cold water before chemicals are applied if the temperature is above 30 °C. Wash smaller areas and flush clean to avoid long exposure times or the chemicals drying in.

## Polishing and waxing

### Painted surfaces

After a time, the paintwork can lose its lustre. You can delay this process by waxing the cab regularly. If the cab paint surface becomes mat, use a mild polish. Follow the product manufacturer's recommendations and general guidelines. First wash the vehicle according to the above and allow to dry. Then use a polishing agent or deep cleansing agent with only a small amount of abrasive components. Wax with a liquid wax. Use only clean cloths/rags, etc. Work across the paintwork with mild pressure.

### Chrome plated parts

First wash the chrome with the same agent used for the rest of the cab. Use concentrated washer liquid to remove any film. The chrome can then be waxed with the same wax as the rest of the cab. Never use cleaning agents containing abrasives on chrome parts.



## Care of upholstery

### Washing upholstery

#### Textiles

First vacuum clean to remove loose dirt. Then use a foam cleaning agent to lift away remaining dirt. Avoid scrubbing with hard brushes. When all of the textile surfaces are treated, let them dry overnight. Vacuum clean thoroughly to remove the dry foam and remaining dirt.

For the seats, beds and textile mats, water and a synthetic washing agent can be used. However, never use water or water-based cleaning agents on the headlining and wall panels.

#### Leather

Vacuum clean. Use special cleaners for leather upholstery.

#### Vinyl

Water and a synthetic washing agent can be used.

### Headlining and wall panels

Never use water or water-based cleaning agents.

#### Seat belt

Water and a synthetic washing agent can be used.

### Floor mats and engine cover upholstery

Vacuum clean and brush clean. Wash with water occasionally, especially during the winter.

### Removing stains

Treat stains as quickly as possible!

#### Textiles

Remove loose particles of stains. Pick up as much as possible with dry rags. Vacuum clean around the stain

so that dirt around the stain is not dissolved. Treat the stain from the outside inwards towards the middle, with stain remover. Dry off parts of the stain that are dissolved. Treat the stain again and dry off dissolved parts. Continue until the whole stain is removed.

Be very careful with the amount of stain remover, to avoid the stain dissolving and becoming larger.

## **Leather**

Use lukewarm, mild soapy water. Never scrape or rub. Never use strong solvents such as petrol, white spirit or alcohol.

## **Vinyl**

Never scrape or rub. Never use strong solvents such as petrol, white spirit or alcohol.

## **Paintwork damage**

The paintwork is an important part of the truck's protection against rust, and should therefore be checked regularly for damage. Damage to paintwork requires immediate attention to ensure that rust does take hold. The most common types of paintwork damage, and the damage you can repair yourself are:

- Small paint damage and scratches
- Wear on wing edges and door thresholds

**When touching up, the vehicle should be well cleaned and dry and have a temperature above +15°C.**

### **Touching up small paint damage**

Material:

- Rust remover (cold phosphating agent) – tube or can.
- Undercoat – can
- Spray paint or touch-up pen (the top of the pen contains abrasive paste for after treatment.)
- Penknife or similar

- Brush

**If the damage has not reached the underlying metal** and a damaged paint layer is still in place, the paint can be applied directly after light scraping to remove any dirt.

If the damage has reached the underlying metal proceed as follows:

**1** Scrape the damaged surface down to bare metal and chamfer the edges of the paint with a penknife or similar (figure 1).

**2** Apply rust remover (mind your eyes and skin), wait a few minutes and then flush thoroughly with water. Dry quickly!

**3** Stir the undercoat (primer) well and apply several coats using a fine brush or match (figure 2).

**4** When the undercoat is dry, apply the top coat with a brush. Make sure the paint is stirred well and apply several thin coats and let dry between applications.

**5** For scratches, work as above but to protect the undamaged paint it may be necessary to mask off (figure 3).

**6** Wait a few days and then apply the after treatment. The top of the pen contains abrasive paste for polishing the touched up surfaces. Use a soft cloth and small amount of abrasive paste.

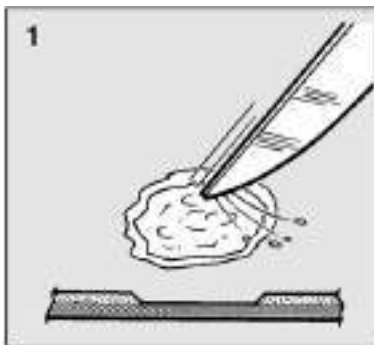

J0008158

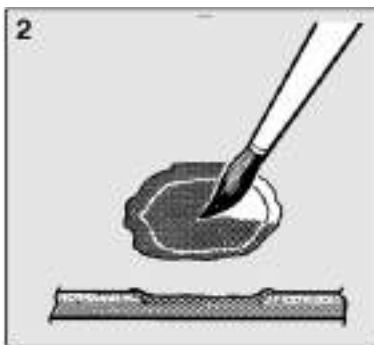

J0008159

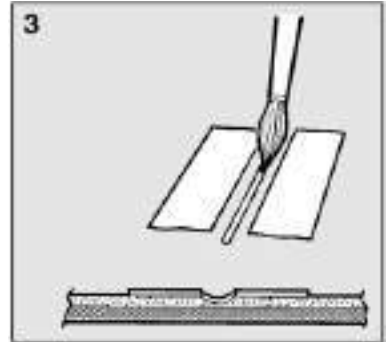

J0008160

## Care of aluminium rims

Aluminium rims are often exposed to different types of dirt such as road dirt, oil, asphalt, tar and brake dust. To protect the rims from discolouration, oxidation and unnecessary wear, regular maintenance is required. For additional protection a protective wax must be used, e.g. when driving is slush, salted roads or environments close to the sea.

Clean the aluminium rims regularly. First flush with water, preferably using a high pressure washer. Use a brush to clean the rim. For difficult dirt, a cleaning agent for aluminium rims may be used. Rinse with clean water afterwards.

To maintain the rim's shine, a polish for aluminium rims should be used after cleaning.

Clean the aluminium rims regularly. Flush with water, preferably using a high pressure washer. Use a sponge or rag to clean the rim. A mild cleaning agent may be used to remove stubborn dirt.

Polish or cleaning agents with abrasive action must not be used as this will damage the rim's surface.

## Care of steel rims

Steel rims are often exposed to different types of dirt such as road dirt, oil, asphalt, tar and brake dust. To

## 522 Maintenance

protect the rims from discolouration, oxidation and unnecessary wear, regular maintenance is required. For additional protection a protective wax must be used, e.g. when driving in slush, salted roads or environments close to the sea.

Damage to the rim's paint must be remedied immediately to prevent corrosion.

Clean the rims regularly. First flush with water, preferably using a high pressure washer. Use a brush or sponge to clean the rim.

For stubborn dirt, an alkaline cleaning agent (pH>7) may be used.

### Tools

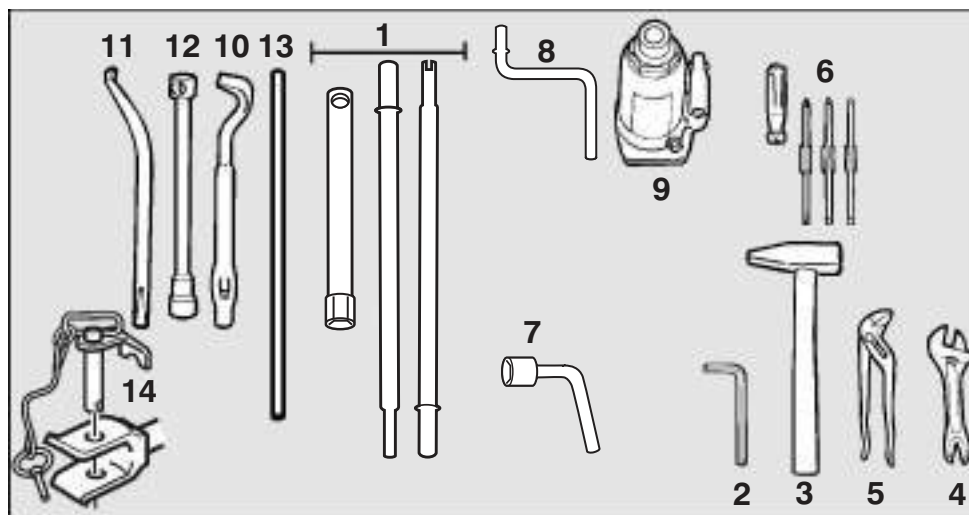

J199126

- 1 Socket for changing wheels and two combination pliers (only for vehicles with disc wheels)
- 2 Socket head key for oil plugs (extra equipment)
- 3 Hammer
- 4 Adjustable wrench (extra equipment)
- 5 Polygrip pliers (extra equipment)

- 6 Combination screwdriver (extra equipment)
- 7 Socket wrench for tilting cab
- 8 Crank handle
- 9 Jack
- 10 Opening lever for changing tyres (only trucks with spoked wheels)
- 11 Closing lever for changing tyres (only trucks with spoked wheels)
- 12 Socket wrench for changing wheels (only trucks with spoked wheels)
- 13 Handle for changing wheels (only trucks with spoked wheels)
- 14 Drawbar for towing

## General information about oils and greases

Lubricating service is very important when it comes to service and maintenance of the truck. Vehicle components such as the engine, gearbox, rear axles, etc., must be lubricated with either oil or grease. The following information about oils and greases is important. Your Volvo dealer has more information on the complete range of Volvo lubricants.

### Oils

For components that are lubricated with oil, the **grade**, **viscosity and service interval** are very important. The type of oil to be used for a specific component depends on the oil's **grade and viscosity**. This information can be found on the container and/or on the oil's product information sheet. When a specific part number is recommended, the part will always have the correct grade and viscosity for the purpose.

### Synthetic oil

Synthetic oil is being used increasingly for the lubrication of vehicles. The raw material for these oils is the same as for mineral based oils, raw oil, but the

manufacturing processes are rather different. As a rule, synthetic oil has better temperature stability and cold properties but its friction properties sometimes result in synchronisation faults. Synthetic oil can also have a negative effect on sealing materials. It is therefore important that approved synthetic oil is used.

A synthetic oil is not necessarily better than a mineral oil. This is however a common misunderstanding and extended oil replacement intervals are therefore assumed. The service interval recommended by Volvo apply irrespective of whether the oil is mineral-based or synthetic.

### **Grade**

A large number of grade designations are used. Different oil types have different grade designations.

### **Viscosity**

Viscosity is a very important property in an oil. It is a measure of the runability of the oil, which effects the thickness of the oil film and fuel consumption. The ambient temperature in the area where the truck is used, determines which viscosity is recommended. There are two systems, called SAE viscosity grade classifications, which divide oils into viscosity grades (such as SAE 10W, SAE 80W-90 etc.) Engine oils and transmission oils belong to two different systems. It is therefore always important to know within which system the viscosity grade is specified. For example, engine oil with a viscosity grade SAE 40 has approximately the same viscosity as transmission oil with the viscosity grade SAE 90. However, in both systems a higher number indicates a higher viscosity.

### **Service interval**

When it has been decided which oil should be used (i.e. the quality and viscosity are known), the recommended service interval is fixed.

## Grease

For components that are lubricated with grease, the **grease type** and **service intervals** are very important. The type of grease to be used for a particular component is given under each component respectively. The information can be found on the grease container and/or on the grease's product information sheet. In some cases, using grease with a particular Volvo part number is recommended. If this grease is used, the correct type is automatically obtained.

### Grease types

Type of grease is determined by a number of different properties, for example:

- Type of thickener, which can be lithium, lithium complex, polymer or clay.
- Grease consistency, specified by the NLGI number.
- The presence of EP additives.
- The occurrence of solid lubricants, such as graphite, copper or molybdenum sulfide

### Service interval

When it has been decided which oil should be used the recommended service interval is fixed.

## Engine

### Oil recommendations

Low-emission engines put great demands on the engine oil. In order to ensure a long life span with maintained low emissions and low fuel and oil consumption, it is necessary to use engine oil that is better than that normally used in older engine generations.

Volvo has developed the earlier VDS and VDS-2 specifications and modified them for Euro 3 engines.



# 526 Maintenance

This new specification is called Volvo Drain Specification-3 (VDS-3). VDS-3 consists of still stricter requirements for piston cleanliness and cylinder polishing compared to VDS-2, to ensure the engines' durability and reliability. In VDS-3, the quality requirement for ACEA E7 is included, which ensures the performance requirements not covered by VDS-3 field test. VDS-3 comprises not only the field test of Volvo D12 engines, but also the most strict engine requirements covered by the ACEA E7 requirement specification.

VDS-3 also covers the same viscosity classes as VDS-2, i.e. 5W-30, 5W-40, 10W-30, 10W-40, 15W-30 and 15W-40. VDS and VDS-2 oils can of course be used in Euro 3 engines as well but with shorter oil change intervals.

## Oil grade

VDS, VDS-2, VDS-3

alternatively API CF, CF-4, CG-4, CH-4, CI-4 or ACEA E2, E3, E4, E5, E7

Note that the combination of several of the above mentioned qualities is required in some cases.

## Viscosity

The viscosity is selected in accordance with the table. The temperature values refer to constant ambient temperatures.

1) Only VDS-2 or VDS-3 oils.

VDS-3 approved oils in viscosity class 5W-30 can be used up to +30 °C.

## Note!

Extra oil additives must not be used. This includes engine and metal treatment additives added to the engine oil.

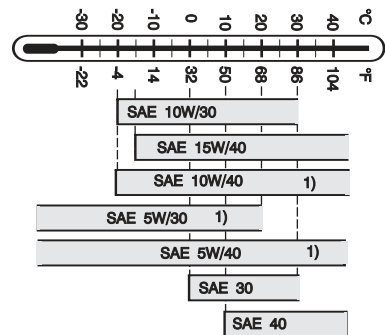

## Note!

When using 10W/30, fuel consumption can be lower than when 15W/40 is used. Be aware, however, of the temperature interval recommended for 10W/30.

## Fill with oil

Check the oil level with the truck standing on a level surface and after the engine has been turned off for at least 30 minutes. Top up the oil when the level approaches the lower mark. **Do not overfill!**

Top up with oil through the filler pipe behind the service hatch.

Fill carefully so that the oil does not run outside. Oil that runs outside can damage other parts of the engine.

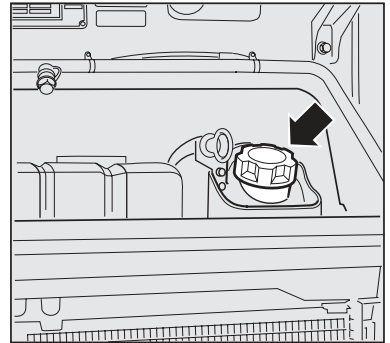

## Fill with oil

Check the oil level with the truck standing on a level surface and after the engine has been turned off for at least 30 minutes. Top up the oil when the level approaches the lower mark. **Do not overfill!**

Top up with oil through the filler pipe behind the service hatch.

Use the side filler pipe on the left of the engine when the cab is tilted.

Fill carefully so that the oil does not run outside. Oil that runs outside can damage other parts of the engine.

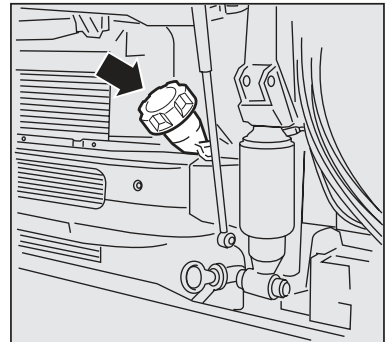

## Change engine oil

The drain plug (A) is located in the bottom of the sump. Drain the oil directly after a trip while it is still thin. Always replace the full-flow filter (B) and the bypass filter (C) at the same time as the oil is changed. Use only Volvo original oil filters.

- 1 Remove any sound baffles underneath the engine
- 2 Clean around the drain plug
- 3 Remove the drain plug
- 4 Drain the oil
- 5 Clean the filters and filter brackets externally to prevent dirt from entering when the new filters are fitted
- 6 Loosen the existing oil filters and dispose of them. The oil filters are of the disposable type and should always be scrapped after use
- 7 Clean the sealing surface (2) for the oil filter seal and the surrounding surfaces on the filter bracket thoroughly
- 8 If the oil filter bracket has been designed with a protective edge (1) for the oil filters, clean the inside of the protective edge carefully as well
- 9 Apply a thin film of oil to the rubber seals on the new oil filters
- 10 Screw on the oil filters by hand until the rubber seals just touch the sealing surfaces
- 11 Then turn an additional 1/2 to 3/4 turn (or as specified by the marking on the filter)
- 12 Fit the drain plugs with new gaskets and fill with fresh oil. Use the side filler on the engine to fill with oil
- 13 Put back the sound baffles underneath the engine if previously removed

### Caution!

Hot oil can cause burns. Take care to avoid spilling oil when topping up. Oil spilt on the engine can affect cooling performance.

### Note!

The filters must not be cleaned, replacement is the only measure that may be taken. Always replace the filters when the oil is changed.

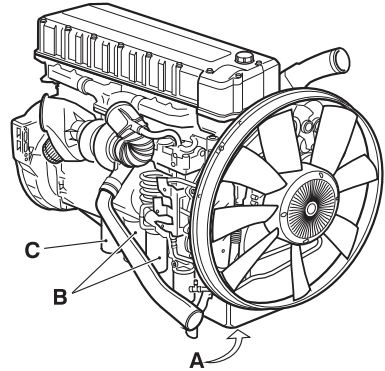

J1007362

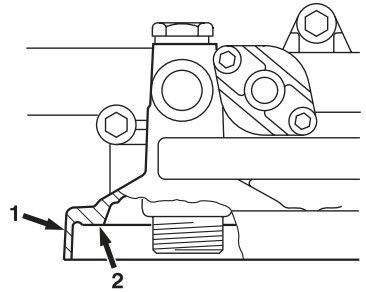

J1007781

## Oil change volumes

Engine type	Oil change volume (litres) including approximate volume for oil filter	Oil volume in litres between dipstick Max-Min marks
D9A	28	6
D9A/D9B OILS-ST, D9B OILS-PL	33	5
D11A (EU-III)	36.5	5
D11B (EU-IV)	36.5	5
D13A/D13B OILS-PL	33	8
D13A/D13B OILS-ST	37	6
D16C, D16E	42	9

## Service intervals

The interval for engine oil replacement varies considerably depending on how the truck is equipped, what it is used for, the type of terrain where it is driven, the grade of engine oil, the quality of the diesel fuel, fuel consumption, the weight of the truck combination, etc, etc. Ask your Volvo dealer for the service schematic for your own truck.

# 530 Maintenance

---

The first oil and filter change is at the warranty service after 10 000 km or 4 weeks, whichever occurs first. The exceptions are all FM and FH trucks made in Europe. They do not need warranty service on their engines.

## **Limitations in the service intervals for D9B, D11A/D11B, D13A and D16E**

- No oil change interval may exceed 12 months for these engines.
- If the sulphur content of the fuel exceeds 0.05 per cent by weight, the oil change interval should be reduced to 2/3 taking into account the distance driven and engine running hours.
- If the sulphur content of the fuel exceeds 0.5 per cent by weight, the oil change interval should be reduced to 1/3 taking into account the distance driven and engine running hours.

## **Limitations in the service intervals for other engines**

- No oil change interval is allowed to exceed 6 months.
- If the sulphur content of the fuel exceeds 0.5 per cent by weight, the oil change interval should be halved. This is to be applied irrespective of mileage, engine hours or fuel volume consumed. Fuels with an extremely low sulphur content, e.g. environmentally classified fuels, do not allow lengthening of service intervals.
- Long life full-flow filters, must be used if the oil change intervals exceed 30,000 km.

## **Fuel system**

REMEMBER to always observe cleanliness when working with the diesel engine fuel system. Make sure the tank is as full as possible to avoid condensation.

## **Note!**

These restrictions in sulphur content and oil change intervals can even be used on older engines, but it is not a demand.

This applies without regard to distance, engine hours, calendar time and fuel consumption. Fuel with an extremely low sulphur content, i.e. environmentally classified fuel, does not allow lengthening of service intervals.

Ensure the area around the filler opening and the filler cap is clean when refueling. Take care to filter fuel being taken from your own tank or drum and make sure all receptacles are clean.

## Diesel fuel— quality and function

### General quality requirements

The composition of fuel plays a vital role in the function, service life and emission spectrum of an engine. In order to achieve specified levels of performance with regard to power and fuel economy and to fulfil emission requirement legislation, only fuel fulfilling legal requirements and national and international standards may be used. These standards are the minimum requirements for commercial fuel and are frequently prepared in consultation with the oil companies and the automotive industry. Examples are:

- EN590 (with nationally adapted cold requirements)
- ASTM D 975 No 1–D and 2–D
- JIS KK 2204

Some countries have more stringent demands for environmental reasons than is required by the basic standards, such as in the following countries:

- Sweden – Environmental class 1 and 2
- Finland – So called City-diesel
- Denmark – Special qualities for buses and distribution vehicles
- California – CARB specification

These fuels exhibit **better exhaust emissions** than standard fuels and can therefore be recommended. They may give slightly lower engine power and a slight increase in fuel consumption.

### Sulphur content

The sulphur content of diesel fuels should be **as low as possible**. Sulphur is converted to sulphur dioxide in the engine and is then converted to sulphuric acid in

### Note!

The injection equipment **must not** be adjusted to compensate for any loss of power.

the atmosphere, which contributes to acid rain. The particle emissions increase with the sulphur content. The sulphur content of the fuel affects the oil change intervals. Fuels with extremely low sulphur content, such as environmentally classified fuels, do not permit the oil change interval to be extended.

## **Viscosity and density**

Viscosity and density have a direct influence on the performance, emissions and service life of an engine. Low viscosity and density reduce engine power. Unusually high viscosity and density effects exhaust emissions negatively and can shorten the life of the injection equipment.

Recommended values:

- viscosity: 1.5 cSt —4.5 cSt at 40°C
- density: 810— 860 kg/m<sup>3</sup> at 15°C

## **Lubricity**

Volvo recommends a lubricity limit not exceeding 460 µm at 60°C, according to the HFRR test (ISO12156).

## **Ignition properties, cetane number**

A short ignition delay (high cetane rating) is important for low emissions, particularly in low emission engines. With low cetane numbers (40-43), the content of hydrocarbons (smell), nitrous oxides and particles will increase, as will the engine noise. The starting ability of the engine is also considerably reduced. Volvo recommends that the cetane number should exceed 45 with regard to technical aspects and should exceed 53 with regard to emissions.

## **Water and particles**

You must ensure that water and particles do not get into the fuel or the fuel tank, since they cause corrosion and wear to the fuel injection equipment. Water also facilitates the growth of bacteria and mould in the tank, which can cause filter blockage. In cold weather, water that has not been dispersed in the fuel

can freeze and block the fuel supply. On markets where water and particles are commonly found, a pre-filter and water separator must be fitted.

### Properties at low temperatures

The resistance of the fuel to low temperatures is limited by its ability to pass a filter. The low temperature requirements for fuel in various geographical regions and seasons are defined in national standards. **Oil companies are responsible** for ensuring that low temperature properties are acceptable at all times of the year.

### Additives

It is always the oil companies who are responsible for ensuring that the correct proportions of additives are present in the fuel as regards ignition ability, lubrication and low temperature properties. Volvo do not allow using other fuel additives and other types of fuels. Volvo do not allow addition of additives or other fuels in the tank. The only exception is kerosene, see the recommendation below.

### Paraffin/Kerosene

Paraffin (kerosene) may only be used to improve low temperature properties when necessary. This should be done in consultation with the oil company that markets the diesel fuel in question. Low temperature properties are improved by about 2–3 °C per 10% addition of paraffin. **It is not permitted to add more than 20% paraffin (kerosene)**, since the viscosity, density and cetane rating fall, which reduces engine power and the starting ability of the engine. In addition, the exhaust emissions will increase.

Note that the max. limit for the mixture's lubricating ability of 460 µm at 60 °C must never be exceeded. For example, it is not permitted to mix paraffin with Swedish environmentally classified fuels. If you change fuel quality to environmentally classified fuels or if you add paraffin, old deposits in the fuel tank and fuel pipes can be dissolved and can accelerate filter



blockage, with subsequent performance impairment and possible malfunction.

### Gasoline and alcohol

Petrol and alcohol are not fuels for diesel engines. Petrol (gasoline) and alcohol raise the octane rating and lower the cetane rating (ignition properties). In addition, the lubricity is considerably impaired. The components in the fuel system can be damaged by petrol (gasoline) and alcohol. In addition, petrol (gasoline) and alcohol lower the flash point, which affects the explosion limit and fire safety. Because of the lower boiling point, the risk of vapour lock in the system is increased since the fuel can boil in the cylinder head etc.

### Diesel boosters

Many manufacturers of commercially available additives (so called diesel boosters) promise reduced fuel consumption and improved lubricity, although they do not have any demonstrable effect whatsoever on either fuel consumption or lubricity.

Volvo does not accept any responsibility for warranty claims if these additives have been used and it is not Volvo's policy to test or evaluate these additives.

### FAME

FAME (Fatty Acid Methyl Esters), also called "biodiesel" are available on certain markets both as in its pure state and as a mixture in diesel fuel. FAME is also known as e.g. rapeseed methyl ester (RME) and sunflower/Soya methyl ester (SME). When mixed in normal diesel fuel, the concentration of FAME is maximum 5%, in accordance with EN590.

**Raw vegetable oil or animal oils do not fulfil EN14214 and shall not be used as a fuel or a mixture component for diesel engines. These products are not approved by Volvo and the use of unapproved products voids the guarantee.**

When using FAME:



### Caution!

Petrol (gasoline) and alcohol must never be mixed with diesel fuel!

### Note!

It is not permissible to add diesel boosters to the fuel.

- **the specific FAME service intervals and maintenance intervals apply. These are shorter than the normal intervals. Contact your Volvo workshop for complete information concerning care, maintenance and guarantees when using FAME.**
- can fuel consumption increase somewhat.
- can engine power be reduced somewhat.
- fuel consumption data is not shown in the driver's display or Dynafleet correctly, since calculations are based on use of ordinary diesel fuel.
- the vehicle can smell different and some smoke can be emitted at start up.

Cold weather characteristics for FAME are not good. The high viscosity at low temperatures can increase the risk for damage to the fuel injection system or that the fuel filter is blocked. Using a fuel heater can improve the characteristics somewhat. During cold weather conditions it is therefore recommended to contact the supplier of FAME concerning the temperature recommendations that apply. With problems starting during the winter, use normal diesel fuel.

Think of the following when using FAME:

- Regular checks of the oil level are necessary since the oil can be diluted with unburnt fuel.
- FAME has certain solvent properties and e.g. dissolves dirt and deposits in the tank. If the vehicle has previously been run on diesel or if one suspects that the tank can contain dirt or deposits, then a number of fuel filter replacements are recommended. The tank may also need to be cleaned out. Contact your Volvo Workshop for more detailed information.
- FAME is more sensitive for bacteria and water contaminants than diesel fuel. Specific conditions therefore apply to storage of FAME, contact your fuel supplier for instructions.

- Use up most of the fuel in the tank before changing to a new fuel. This is to avoid bacteria spreading in the tank.
- If the vehicle is not used for a period of at least 4 weeks, the system should be flushed through with diesel by driving on at least one full tank.
- Engine/cab heaters are not adapted to run on FAME, so a separate diesel tank must be fitted. Engine/cab heaters shall only use diesel in accordance with EN590.
- FAME is aggressive to paint and certain types of rubber and plastic. If FAME comes into contact with a painted surface, wash it off immediately and thoroughly to avoid damage.

## Used oil

Used oil and two-stroke oil considerably shorten the service life of the injection equipment. In addition, the exhaust emissions increase if these oils are used.

## Fuel at airports and military operations

It is normal practice that trucks at airports and in military operations use aircraft jet fuel or various military grades of diesel. It is important to monitor the specifications of the fuel in question and it is essential to find out correct data about all the additives that have been put into the fuel in question. **If you have a question, contact Volvo Trucks!**

## Changing fuel filter

Change the fuel filter when doing an oil change, or as required, for example if:

- the fuel pressure drops
- the power output decreases
- the fuel quality is uneven
- the symbol for blocked fuel filter starts to light

1 Clean the filter bracket thoroughly

## Note!

It is not permissible to add used oil or two-stroke oil to the fuel tank.



### Caution!

Take care not to allow fuel to run over and damage electrical components.

- 2 Remove the filter using a filter wrench
- 3 Moisten the new filter gaskets with diesel
- 4 Screw on the filter by hand until the gasket contacts the sealing surface
- 5 Then turn an additional 3/4 to 1 turn (or as specified by the marking on the filter).
- 6 Bleed the fuel system
- 7 Start the engine
- 8 Make sure the filter is not leaking

**Note!**

The new filter must be empty when it is mounted. Under no conditions may it be filled with fuel before mounting.

**Note!**

If there is a water separator fitted, change the filter in this at the same time as changing the fuel filter. At the same time clean the water level sensor in the plastic bowl under the filter using a soft cloth.

## Filter for fuel tank ventilation

The filter is used in certain markets and should be replaced every 24th month. Under certain conditions the filter may need changing more often, e.g. when driving in dusty environments.

## Priming the fuel system

### Vent the fuel system

Vent the fuel system if:

- The engine has been stationary for a long period.
- The tank has been run dry.

**Note!**

Never prime the system using the starter motor.

### Venting

- 1 Stop the vehicle
- 2 Apply the parking brake
- 3 Tilt the cab
- 4 Remove sound insulation over the left chassis member
- 5 Pump using the hand pump on the fuel filter bracket, pump 200–300 times, until resistance is

felt. Venting is complete. It is not necessary to open any nipples.

- 6 Start the engine and run it at idle.
- 7 If the engine is difficult to start, repeat the venting.
- 8 Let the engine run at idle
- 9 Check for any leakage
- 10 Check that the engine runs evenly
- 11 Fit the sound insulation

## Venting

- 1 Stop the vehicle
- 2 Apply the parking brake
- 3 Turn the key to the R-position
- 4 Press the switch for venting  
A symbol is shown in the display.
- 5 Start the engine and let it run at idle
- 6 If the engine is difficult to start, repeat venting
- 7 Check for any leakage
- 8 Check that the engine runs evenly

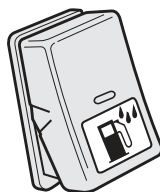

## Draining the fuel tank

Drain the fuel tank of any sludge and condensation annually. By doing this, the risk of water getting into the engine and causing running problems is avoided.

- 1 Place a receptacle under the bottom plug of the fuel tank
- 2 Undo the plug and screw it out a few turns, so that sediment and condensation water start to run out of the drain hole in the plug. Do not remove the plug, or all the fuel will also be drained
- 3 Leave it to run until pure fuel appears
- 4 Screw in the bottom plug
- 5 Empty the container in a place where it will not constitute a risk to the environment

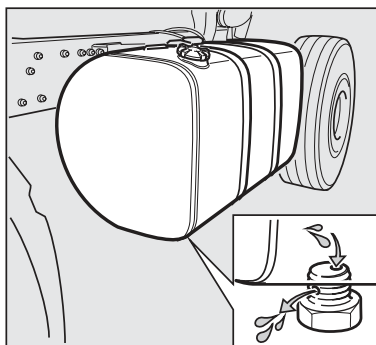

## Changing filter

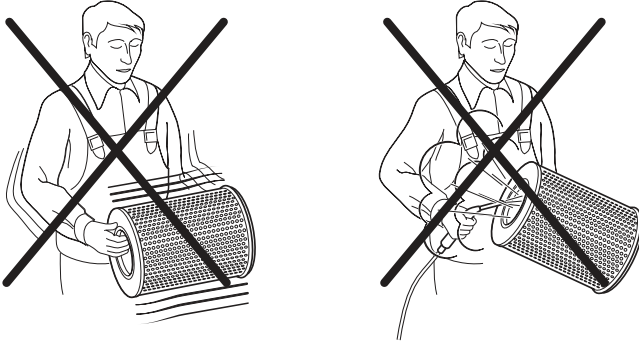

J2018385

### The following general directions apply:

- **The air cleaner filter insert may only be removed for replacement**
- **Filter inserts must not be cleaned**

The filter element may not be removed for inspection, cleaning, etc. since dust and dirt particles can always get into the inlet system's clean side when the filter element is removed.

Any attempts at cleaning such as shaking, blowing with compressed air, etc., will always entail a change in the structure of the filter surface and result in deterioration in its efficiency.

## Changing primary filter

A symbol on the display will be shown to indicate that the primary filter must be changed. The primary filter must be changed at least every 24 months.

When the symbol lights, first check that the net in the air intake is not blocked.



J3014483

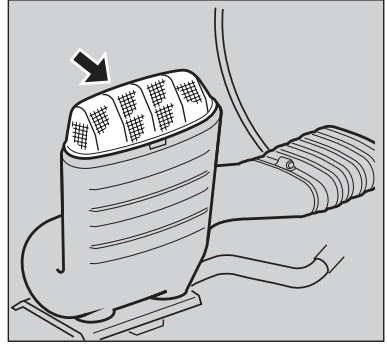

J0011030

- 1 Tilt the cap
- 2 Unscrew the four bolts holding the filter and the filter cover
- 3 Pull out the filter. It may be difficult to grip the filter
- 4 Clean inside the filter housing with a damp cloth. Take special care to ensure that the sealing surface on the corrosion-resistant outlet pipe is clean
- 5 If there is a secondary filter, mark on the secondary filter end that the primary filter has been changed
- 6 Lubricate the new filter seal with the accompanying silicon grease
- 7 Lubricate the cleaned sealing surface on the end of the outlet pipe in the same way. Use only silicon grease! Mineral oils will ruin the seal
- 8 Install the new filter
- 9 Make sure the filter enters the outlet pipe
- 10 Press in the filter hard
- 11 Fit the cover
- 12 Tighten the four retaining bolts
- 13 Write the date of the change on the end of the filter

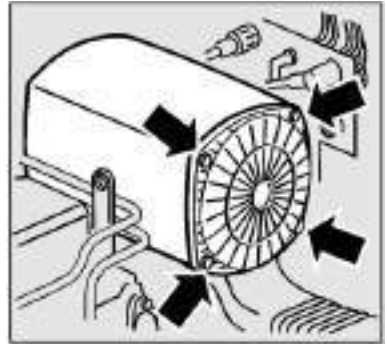

J0008113

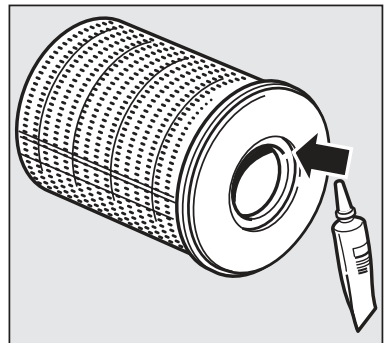

J0008357

- 14 Check that the hoses to and from the filter housing are not damaged and that hose clips are tight
- 15 Check that the rubber bellows between the cab and the chassis are tight against the mating surface
- 16 Check that the rubber valves are intact

**Note!**

Do not touch the filter unnecessarily. The filter must not be reused!

**Note!**

If the control lamp lights after a primary filter change, then even the secondary filter shall be changed, if fitted.

## Changing secondary filter

Change the secondary filter after changing every third primary filter or at least every 48 months.

- 1 Loosen the hose clip that is securing the filter element (see illustration)
- 2 Pull out the filter element
- 3 Lubricate the steel pipe end with the accompanying silicon grease. Lubricate the part to be mounted in the rubber filter housing connection as well as the sealing surface for the primary filter. Use only silicon grease. Mineral oils will ruin the seal and the rubber connection
- 4 Put in the new secondary filter
- 5 Press in the filter until it bottoms
- 6 Write the date of the change on the end of the filter
- 7 Fit the primary filter
- 8 Fit the cover
- 9 Tighten the retaining bolts
- 10 Tighten the hose clip that is securing the secondary filter in the air cleaner

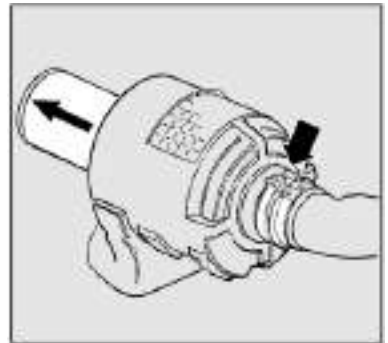

J0008170



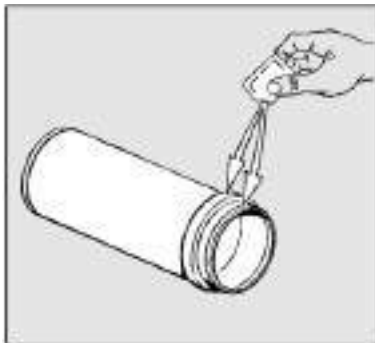

J0008151

## Drain the cooling system

Remove the expansion tank cap to facilitate draining.

All drain points must be open to completely drain the cooling system.

Drain in the following order:

- 1 Radiator
- 2 Cylinder block  
Once the system is empty, also:
- 3 Any gearbox oil cooler, see below

Drainage point on oil cooler for gearbox:

Drain also the oil cooler for the gearbox when draining the cooling system.

Detach the hoses and drain.

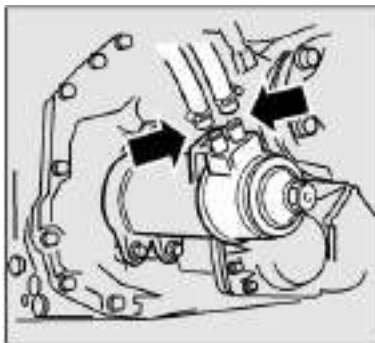
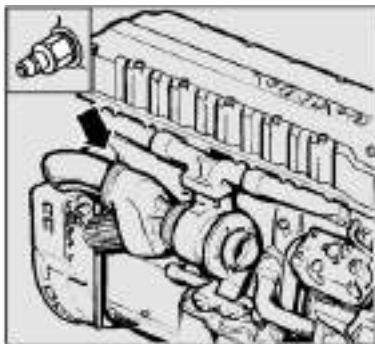

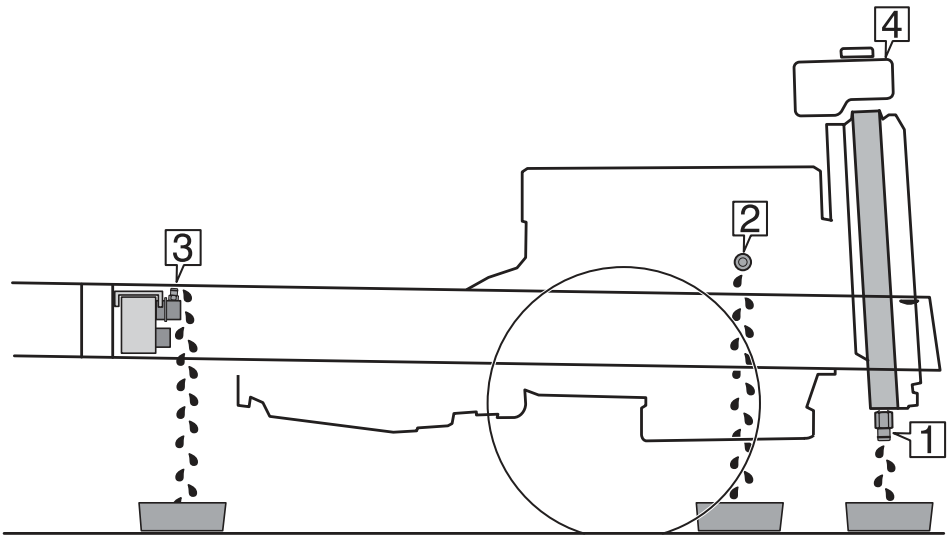

J2019327

Remove the expansion tank cap (4) to facilitate draining.

All drain points must be open to completely drain the cooling system.

Drain in the following order:

- 1 Radiator
- 2 Engine  
The drain plug is at the front edge on the right side of the engine.
- 3 Extra radiator if fitted

## Service intervals

	Coolant change	Other
Volvo Coolant VCS	500 000 km or every 48th month.	Volvo Coolant VCS shall not be used with a coolant filter.

Note that Volvo Coolant VCS cannot be mixed with other coolants and anti-corrosive agents.

## Anti-freeze

The mixing ratio with Volvo coolant VCS shall be 40 - 60 %.

Protection against freezing down to:	Mixture of concentrated antifreeze
-25°C	40 %
-30°C	46 %
-38°C	54 %
-46°C	60 %

### **Note!**

−46 °C is the maximum freezing point depression. Increasing the concentration above this depletes the frost protection.

### **Note!**

Mixing with other types of concentrated coolant can result in inferior anti-corrosive properties resulting in damage to the engine.

The system must be flushed carefully during coolant replacement.

The table shows the approximate quantity of concentrated antifreeze required for frost protection to the stated temperature.

## Fill with coolant in an empty system

- 1 Stop the engine
- 2 Set the heater control to warm
- 3 Fill coolant to MAX in the expansion tank
- 4 Run the engine warm
- 5 Allow the engine to cool down
- 6 Check the coolant level

### **Note!**

Only a guideline, depends on vehicle settings and equipment.

The cooling system is ventilated automatically.

Engine	Coolant volume (litres)
D9A FM9, D9B FM, D11A, D11B	37
D13 FH	44
D13 FM	42
D16C, FH16	52

## Viscous fan

The vehicle must be driven directly to a garage if the coolant temperature or coolant level warning diode comes on while driving and there is a fault with the fan so that the fan can be checked.

### **Note!**

**Never cover the radiator.** The engine is fitted with a charge air cooler and is therefore very sensitive to air flow blockage (overheating and reduced power). Do not therefore cover the radiator (charge air cooler) with boards, radiator blinds etc.

## Electrically controlled fan

On electrically controlled fans, it is not just the coolant temperature that decides when the fan should start.

The fan may therefore start when a thermostatically controlled fan would not start.

## Check the drive belts (Multi-V)

Check the engine drive belts. Replace belts if any pieces of the groove have broken off.

The fan belts are tensioned automatically, which reduces the risk of slip and increases service life. The generator/compressor (air conditioning) drive belts are not tensioned automatically and their tension must therefore be checked. Contact your Volvo-garage.

## Working on the electrical system

There are a number of jobs on the electrical system which the driver may need to do himself, such as changing fuses.

**The truck has an alternator and when working on the electrical system the following should be observed:**

- 1 When putting in batteries make sure they are correctly connected
- 2 Never run the alternator with a disconnected battery. The batteries and alternator must not be disconnected while the engine is running
- 3 The negative terminal on the battery should always be disconnected first and connected last, for example, when changing the battery. This reduces the risk for short circuits and sparks which can be dangerous due to hydrogen gas
- 4 Help-start batteries must be correctly connected to prevent damage to the rectifiers in the alternator, positive to positive and negative to negative
- 5 When charging the batteries at least one of the battery cables (negative or positive) must be disconnected
- 6 When working on the electrical system of the truck, the current must be switched off

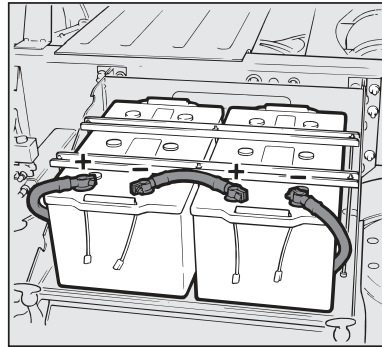

J0008252



### Caution!

So-called start help units must not be connected, because these can give very high voltages, which can in turn damage control units.

## Instructions for electrical welding

These instructions generally apply to all types of electric welding work on vehicles.

Welding must be carried out with great accuracy to achieve a satisfactory joint. Great care must be taken to avoid damage, personal injuries and accidents.

When carrying out welding, it is important that the following measures are taken in order to avoid personal injuries or damage to the vehicle:

- The welder must have sufficient knowledge of welding on vehicles. For this reason, a trade education is necessary
- It is important to prepare the welding area carefully. Heat sensitive parts such as cabling and air ducting shall be protected or removed
- The welding area and the location of the welding machine's earth connection must be clean. I.e. paint, corrosion, oil, grease and dirt etc shall be removed.
- The cable clip should be in contact with the material to be welded to prevent damage to any electrical components. The connecting clip must also make good contact with the material being welded. This is to prevent damaging electrical components. If two parts are to be welded together, it is essential that both of these are connected to the welding machine's earth connection.
- Ensure that no electrical casings (e.g. the control unit) come into contact with the welding electrode or the welding machine's earth connection.
- A direct current is generally used for welding
- When carrying out welding in a cab, the airbag should be disconnected to avoid personal injuries
- When carrying out welding in a cab, put the starter key in stop mode and disconnect connectors to instrument cluster and other control units

After completed welding — paint the welded area.

## Connection of electrical accessories

- Always use the stipulated size of fuse and the correct wire cross-section. Dimension continual loads on fuses to not more than 80% of their rated current
- When working on the electrical system of the truck, the power must be switched off
- Always use Volvo original connectors (terminals, insulators, fuses etc.)

### **Note!**

Fire risk if fuses are too large.

### **Cigarette lighter as a power point**

The cigarette lighter point is designed to heat up the cigarette lighter and is dimensioned for loads of up to ca. **4 Ampere** . It is strongly recommended that you do not use the socket as a power point. Your Volvo dealer can give you information about the connection of other types of electrical sockets.

### **12 volt electrical outlet**

The electrical outlet beside the cigarette lighter may be loaded to max. **10 Ampere** .

### **Connection of prepared equipment**

Use the premounted cable harnesses for connecting e.g. telephone chargers and coffee makers. Contact a Volvo workshop if you are uncertain.

### **Connection of non-prepared equipment**

Non-prepared equipment refers to equipment for which the cable harnesses have not been factory installed and supplied with the truck. Please ask your Volvo dealer to arrange for connection.

## Checking electrolyte level in batteries

The level should be 5 – 10 mm above the plates.

Fill with battery water if required. Do not fill more than 10mm above the cell plates.

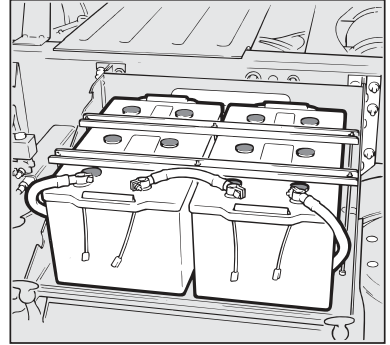

J0008268

### Note!

Battery electrolyte contains corrosive sulfuric acid. Remove electrolyte spill immediately from skin. Wash with soap and plenty of water. Seek medical help if the electrolyte comes into contact with eyes or any other sensitive part of the body. Remember that batteries contain oxyhydrogen gas and are extremely explosive. Short circuits, naked flames or sparks in the vicinity of a battery may cause a powerful explosion resulting in personal injury and material damage.



Use protective goggles when working on batteries.



## Charge status

It is useful to know how discharged a battery is before it is charged, to be able to charge it in the best manner.

The ambient temperature plays a part in both the charging ability and capacity, not until at +25 °C does the battery give 100 % of its capacity. The battery cannot be charged especially well below 0 °C, see table.

The batteries must not be left uncharged. Every third to fifth week, even a “charged” battery needs a maintenance charge, due to self-discharge and possible small consumers <40mA (clocks, tachograph etc.) if the vehicle does not have a main switch. If there is a main switch and a properly connected solution, one can stretch to five weeks between maintenance charging.

Temperature	-18°C	0°C	+25°C
Capacity 20 h (Ah)	50%	85%	100%
Charge acceptance (A)	6%	25%	100%

An alternator can never charge the battery to 100%; in favourable circumstances a maximum level of 90% can be achieved. Complete recharging can only be done with a battery charger over a long period of time (1-2 days). Increased power demand from the alternator and battery may result in the battery being discharged. The easiest way to check the charge is with a voltmeter, but an aerometer (specific gravity gauge) together with a voltmeter gives a more correct result. The diagram below shows the rest potential and state of charge compared with the specific gravity of the acid.

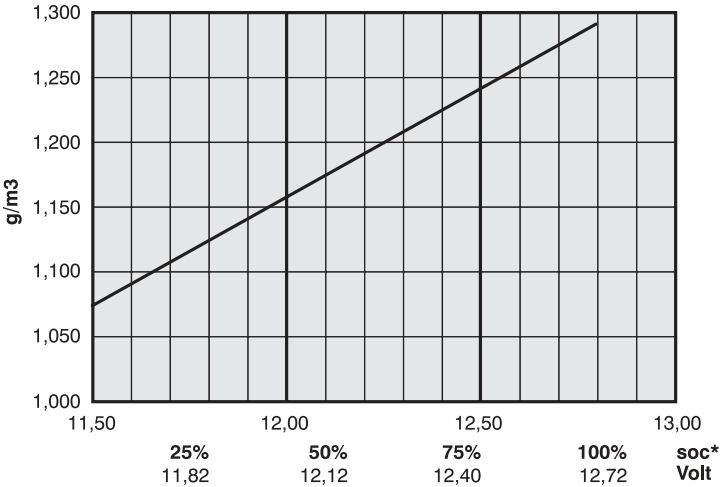

J0010460

\* State of Charge (Charge status)

### Specifications for the electrical system

System voltage		24V
Battery	number	2
	voltage	12 Volt
	capacity	D9: 140, 170 or 225 Ah D12: 170 or 225 Ah

<b>Electrolyte specific weight:</b>	
fully charged battery	1.265-1.290 g/cm <sup>3</sup>
half charged	1.25 g/cm <sup>3</sup>
charge necessary	1.20 g/cm <sup>3</sup>

## Manual gearbox and I-shift

<b>Gearbox</b>	<b>Approximate replacement volume in litres</b>
AT2412C	16
AT2512C	16
ATO2512 C	16
VT1708B	11,5
VT2009B	12
VT2214B	13,5
VT2412B	13
VT2514B	13,5
VT2814B	13,5
VTO2214 B	13,5
VTO2514 B	13,5
VTO2814 B	13,5

If the gearbox has a rear PTO or oil cooler, extra oil must be added as per the following table.

Component	Additional oil volume in litres
Single power take-off BKU/ PTR	0,8
Double power take-off DBKU/ PTRD	0,8
Oil cooler TC-MWO (Cool TW and T1, old designations)	0,1
Oil cooler TC-MWOH (Cool TWH and T1H, old designations)	0,8
Oil cooler TC-MAOH	0,8
Oil cooler TC-MWOH2	0,8
Oil cooler TC-MAOH2	0,8

For several different reasons these gearboxes cannot have the same service recommendations. They have therefore been divided into service categories. The service categories, numbers or letters, can be found on the ID plate on the gearbox. The categories are G, 1, 2, 3 and 4.

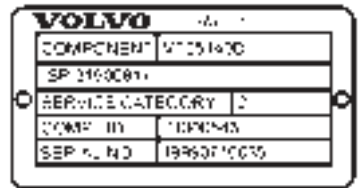

J1006942

### Note!

If the gearbox has no entry under service category on the ID plate, it belongs to service category G.

Two different service recommendations can be applied for the gearboxes:

- **Standard service recommendation**
- **Alternative service recommendation**

The alternative service recommendation provides longer service intervals than standard service

recommendation. The alternative service recommendation demands the use of special oil.

The standard service recommendation and alternative service recommendation both consist of three parts. The three parts are **oil grade**, **viscosity** and **service intervals**. These can be found in the same order on the following pages. The following procedure can be very useful when deciding which oil to use.

- 1 Find out which service category the component belongs to
- 2 Use the information in the table under **Service intervals** and determine the service recommendation to be used
- 3 Use the information under **Oil grade** and **Viscosity** to determine which oil to use

### Oil grade

- 1 Transmission oils: Volvo transmission oils 97305, 97307 or 97315.
- 2 Engine oils: API CE or CF; ACEA E2 or E3.

### **Note!**

Only monograde oils.

### **Note!**

The choice of oil grade affects the service interval; see the table below.

## Viscosity

Viscosity is selected in accordance with the diagram.

Temperatures refer to constant ambient temperatures.

1) Applies to engine oils: Note that multigrade oils are NOT to be used in manual gearboxes. Use only monograde engine oil SAE 30, SAE 40 or SAE 50.

If oil cooler TC-MAOH/-MAOH2 is fitted, engine oil SAE 50 or Volvo Transmission oil 97315 must be used.

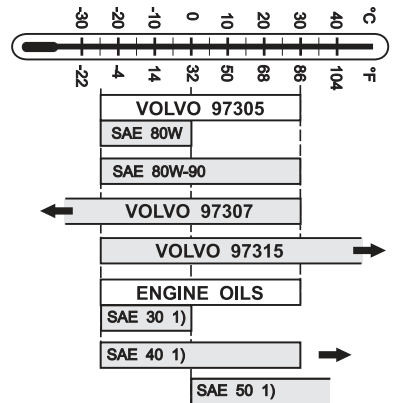

J1008787

## Note!

If the temperature is below  $-25^{\circ}\text{C}$ , use Volvo Transmission oil 97307.

Gearboxes with oil cooler TC-MWO, TC-RWO, TC-MWOH, TC-MWOH2 can be run in ambient temperatures above  $+30^{\circ}\text{C}$  with engine oil SAE 30, SAE 40 or SAE 80W90 or Volvo Transmission oil 97307.

## Service intervals

The service category of the gearbox is dependant on where the vehicle was manufactured. In some markets there can be vehicles with gearboxes belonging to different service categories, and in these cases special care must be taken with the planning of the first oil and oil filter change.

# 556 Maintenance

---

Service category	Intervals
Service categories 1 and 3	First oil and filter change after 10,000 km or 4 weeks, whichever occurs first.
Service categories 2 and 4	First oil and filter change after 400,000 km or three years, whichever occurs first.

Oil grade	Service category		
	G	1 and 2	3 and 4
	Oil and filter change interval (km)		
Volvo Transmission oil 97305 Engine oil SAE30 or 40	120 000/12 months		-
Engine oil SAE50	120 000/12 months	120 000/12 months	120 000/12 months
Volvo Transmission oil 97307	180,000/12 months	400,000/36 months	-
Volvo Transmission oil 97315	180,000/12 months	400,000/36 months	400,000/36 months

- For TRAPP-HD and use on building sites with very hilly terrain, corresponding to VS (Very severe) and VS+ (Very severe+) driving conditions, according to the definitions for "Engine operating conditions (EOC)" which describes the degree of loading on the engine, then transmission oil 97315 or engine oil SAE 50 must be used. The oil exchange interval for transmission oil 97315 is max 2500 driving hours, and for engine oil SAE 50, max 600 driving hours.
- If a PTO or split gear is used for more than 50 % of the driving time, the oil must be changed after max 2500 driving hours for transmission oil 97307, and after max 600 driving hours for engine oil SAE 50 (or SAE 40 or SAE 30).

- If the total weight for the combination exceeds 80 ton and the ambient temperature is above 30°C for more than 1 month per year, the oil change intervals shall be halved.

## Replenishing oil level in gearbox

When the oil level in a gearbox is too low, it must be topped up with oil. The following then applies:

- If the same oil is used to top up the gearbox as the one already in the gearbox, there is no limit to how much oil can be filled or how many times the oil level can be replenished.
- If approved oil other than the one already in the gearbox is used for topping up, then no more than one litre may be used. This applies regardless of how many times the oil is topped up to the correct level. If more oil needs to be added, carry out a complete oil change instead

## Oil and filter changes after a repair to the gearbox

If a component has been repaired or renovated, or if the gearbox has been opened, an extra oil and filter change must be carried out. This change must be carried out at 10,000 km or 4 weeks, whichever is first, after a component has been repaired, overhauled or opened. When the extra oil and filter change has been completed, the component's normal service recommendation applies.

## Checking the oil level

- 1 Remove the sound baffle, if fitted, from underneath the gearbox
- 2 Check that the oil level is between the centre and the maximum level on the transparent level plug in the gearbox (A) (maximum and minimum oil level, see picture)
- 3 Top up with oil as necessary, but first clean round the filler plug (B)

### **Note!**

Do not undo the transparent level plug.



- 4 Remove the air vent hose from the filler plug (B) and unscrew the plug
- 5 Fill with new oil until the level reaches the top half of the maximum and minimum oil levels on the transparent level plug (A) (max and min oil levels, see illustration)
- 6 Apply a layer of thread sealant to the threads of the filler plug (B) and screw the plug on. The pipe on the plug should have the same orientation (pointing diagonally upwards) as before removal
- 7 Install the air vent hose
- 8 Refit any sound baffles under the gearbox

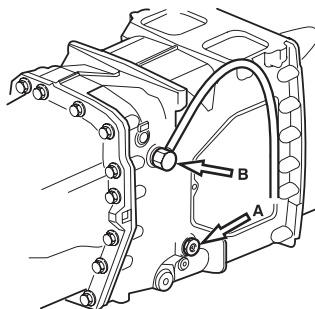

J1006732

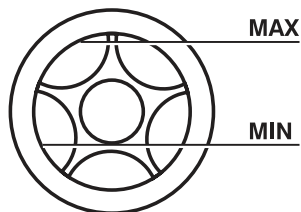

J1007661

## Change oil and filter

Drain the oil immediately after driving. Then it has low viscosity.

- 1 Untighten the drain plug.
- 2 Unscrew the screws holding the oil filter housing (1).
- 3 Remove the filter housing (1).
- 4 Pull out the old filter (2).
- 5 Clean the sealing surface between the filter housing and the gearbox.
- 6 Replace the gasket.
- 7 Fit the new filter.
- 8 Screw on the filter housing.
- 9 Fit the drain plug.



**Caution!**

Hot oil can cause burns.

## Note!

The support tube in the centre of the filter must not be removed / replaced.

- 10 Fill the gearbox with new oil up to the maximum oil level on the transparent level plug (see illustration).
- 11 Run the gearbox for at least one minute in neutral with the clutch pedal released.
- 12 Check the oil level again.
- 13 If the level has dropped, top up with more oil and run the gearbox for another minute.
- 14 Repeat the check and top up until the level does not drop after running the gearbox.

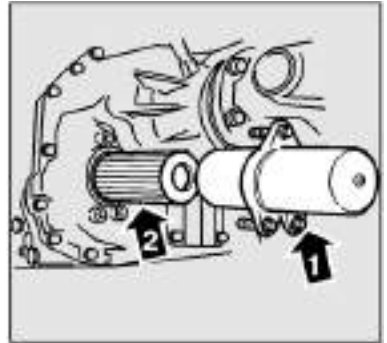

J0008163

- 1 Filter housing
- 2 Filter

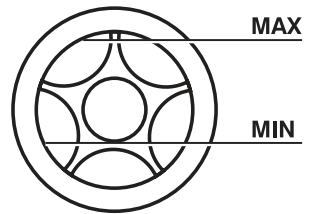

J1007661

Level plug

**Note!**

Do not untighten the level plug.

## Automatic gearbox

**Oil grade**

Transmission oils fulfilling quality requirements of both Dexron III and Allison C4 shall be used.

Gearbox	Oil change volume, approx. litres
VT1705PT	35

Gearbox	Oil change volume, approx. litres
VT1706PT	35
VT1906PT	35
VT2006PT	35
VT2206PT	35
VT2506PT	35

## Viscosity

Transmission oils fulfilling quality requirements of both Dexron III and Allison C4 shall be used. This automatically provides oils of the correct viscosity. These oils must be used irrespective of ambient temperatures.

## Service intervals

- First filter change after 10,000 km or 4 weeks, whichever occurs first. The oil level must be checked after changing the filter. **No oil change shall be performed**
- After the first filter change has been done, the oil and filter shall be changed every 90 000 km or once a year, whichever occurs first
- Under some gearbox operating conditions, shorter change intervals may be necessary. Examples of such are extreme heat and much use of the retarder
- The change interval must be halved for heavy driving or frequent driving under hilly road conditions
- All these types of gearboxes are equipped with a **ventilation filter**, which ensures that air pressure does not build up in the gearbox. The ventilation filter must be kept clean and open, and therefore it must **normally be changed after 24 months**. If the gearbox is operating under very dusty and dirt conditions, it will be necessary to reduce the replacement intervals for the ventilation filter

## Checking the oil level

Check the oil level with the gearbox at operating temperature, 70–90°C to ensure that the oil level is correct.

- 1 Clean round the oil filler cap and dipstick
- 2 Park on a flat surface, apply the parking brake and start the engine
- 3 Put the gear selector in neutral with the engine running at about 1000 rpm
- 4 Wipe the dipstick on a clean lint-free paper
- 5 Check the oil level with the dipstick and top up with the correct grade of oil as necessary. The level should be between the markings on the dipstick. If the oil level is too high it may cause a high oil temperature in the gearbox

**Pay attention to the cleanliness of the oil!**

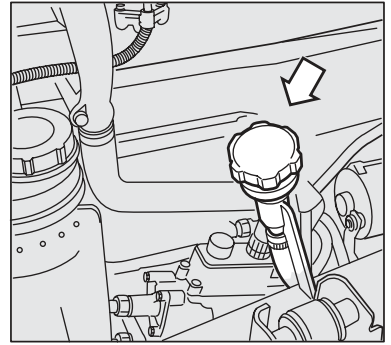

J1007408

## Change oil and filter

- 1 Clean the gearbox and the external oil filters.
- 2 Drain the oil through the sump drain plug (B).
- 3 Unscrew the old oil filters (A).
- 4 Clean the mating surfaces for the oil filters on the gearbox.
- 5 Oil the rubber gaskets on the new oil filters and tighten them by hand in accordance with the instructions on the filters.
- 6 Fit the drain plug (B) with a new sealing.
- 7 Clean round the oil filler cap and dipstick, and fill new oil in the gearbox.

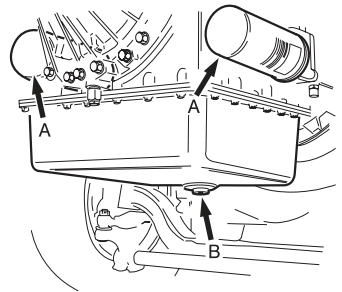

J1006796

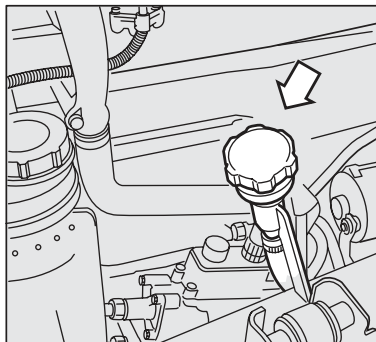

J1007408

## Transfer gearbox

### Oil recommendations

On transfer boxes with a transparent level plug the oil level shall be between the centre and the maximum level on the transparent level plug .

On transfer boxes without transparent level plug, the oil is to be filled up to the edge of the level hole.

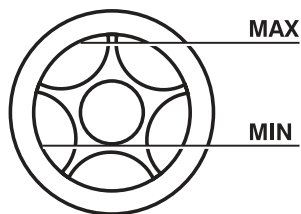

J1007661

Transfer box	Oil change volume, approx. litres
FD7	5,5
VT2501TB	5,5

### Oil grade

- 1 Transmission oils: Volvo Transmission oils 97305, 97307 or 97315.
- 2 Engine oils: API CE or CF; ACEA E2 or E3.

### Note!

Only monograde oils.

## Note!

The choice of oil grade affects the service interval; see the table.

## Viscosity

Viscosity is selected according to the diagram below.

1) For components that are run at stable ambient temperatures higher than +30 °C. Applies to engine oils: note that multigrade oils MUST NOT be used.

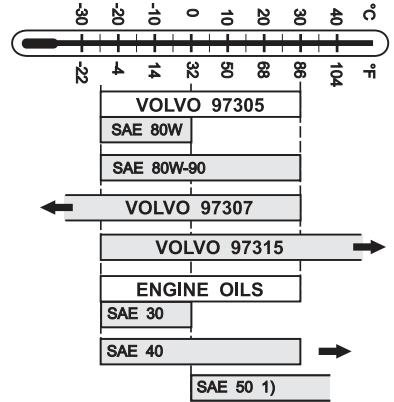

J1008789

## Note!

If the temperature is below -25°C, use Volvo Transmission oil 97307.

## Service interval

First oil change after 10,000 km or 4 weeks, whichever occurs first.

Apply the service intervals in the table:

Oil grade	Service interval, km/months
Engine oil Transmission oil 97305	120 000 / 12
Transmission oils 97307, 97315	180 000 / 12

## Replenishing oil level in transfer gearbox

When the oil level in the transfer box is too low, it must be topped up with oil. The following then applies:

- If the same oil is used to top up the transfer box as the one already in the transfer box, there is no limit to how much oil can be filled or how many times the oil level can be replenished.
- If approved oil other than the one already in the transfer box is used for topping up, then no more than 0.5 litre may be used. This applies regardless of how many times the oil is topped up to the correct level. If more oil needs to be added, carry out a complete oil change instead

## Oil change after repair of transfer box

If a component has been repaired, renovated or opened, an extra oil change must be carried out. This oil change must be carried out at 10,000 km or 4 weeks, whichever is first, after a component has been repaired, overhauled or opened. When the extra oil change has been completed, the component's normal service recommendation applies.

## Checking the oil level

- 1 Check that the oil level is between the centre and the maximum level on the transparent level plug in the transfer gearbox (A) (maximum and minimum oil level, see picture)
- 2 Top up with oil as necessary, but first clean round the filler plug (B)
- 3 Unscrew the filler plug (B) and fill with oil until the oil level is between the centre and the maximum level on the transparent level plug (A) (maximum and minimum oil level, see picture)
- 4 Refit the filler plug (B). If the seal ring on the plug is damaged, change the seal ring

### **Note!**

Do not undo the transparent level plug.

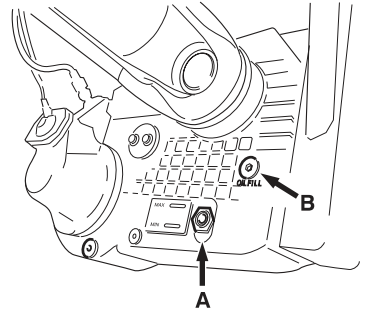

J1007655

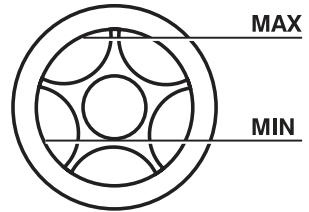

J1007661

## Oil change

- 1 Clean around the drain plug (C) and the filler plug (B).
- 2 Unscrew the drain plug (C) and drain the oil. Unscrew the filler plug (B).
- 3 Fit the drain plug (C). If the sealing ring on the plug is damaged, it must be replaced.
- 4 Fill new oil into the transfer gearbox until the oil level reaches the centre of the transparent level plug (A) (maximum and minimum oil level, see illustration).
- 5 Refit the filler plug (B). If the sealing ring on the plug is damaged, it must be replaced.

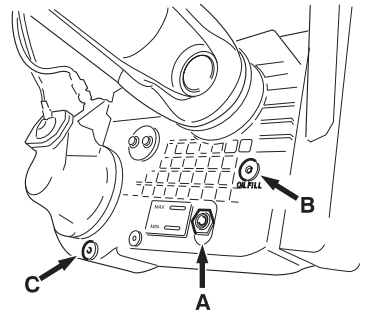

J1007656



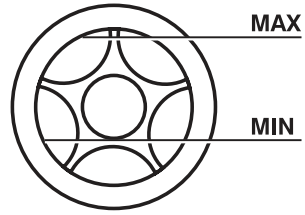

J1007661

### Notel

Do not remove the transparent level plug.

## Driving front axle

### Oil recommendations

Driving front axle	Change volume approx. litres
FS0910HZ	11.5 Note that the hub's change volume is not included. Each hub change volume is approx. 1.5 litres.

### Oil grade

Transmission oil API GL-5.

### Viscosity

Viscosity is selected in accordance with the diagram.

Temperatures refer to constant ambient temperatures.

1) When driving in severe condition or frequently driving on inclines, we recommend SAE 80W/140, SAE 85W/140 or SAE 140 (instead of the normal SAE 90)

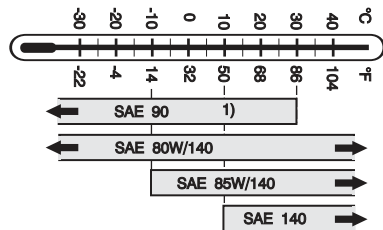

**Note!**

SAE 80W/90 must not be used.

**Service intervals**

- First oil change after 10,000 km or 4 weeks, whichever occurs first.
- After the first oil change, the oil should be changed every 120,000 km or every 12 months, whichever occurs first

**Oil change after repair of driving front axle**

If a component has been repaired, renovated or opened, an extra oil change must be carried out. This oil change must be carried out at 10,000 km or 4 weeks, whichever is first, after a component has been repaired, overhauled or opened.

When the extra oil change has been completed, the component's normal service recommendation applies.

**When replenishing the oil level in the driving front axle**

When the oil level in the driving front axle is too low, it must be topped up with oil. The following then applies:

- If the same oil is used for topping up as the one already in the driving front axle, there is no limit to how much oil can be filled or how many times the oil level can be replenished in the driving front axle
- If approved oil other than the one already used in the driving front axle is used for topping up, then no more than one litre may be used. This applies regardless of how many times the oil is topped up to the correct level. If more oil needs to be added, carry out a complete oil change instead

## Checking the oil level

### Front axle wheel gears

The front axle should be raised.

- 1 Clean around the level/filler plugs (A) for the wheel gears
- 2 Turn the wheel so that the level mark on the level/filling hole is horizontal
- 3 Remove the level/filler plug and check that the oil level reaches up to the edge of the filling hole
- 4 Top up with oil as necessary
- 5 Install the level/filler plugs for the wheel gears. If a seal on any of the plugs is damaged, the seal ring must be changed

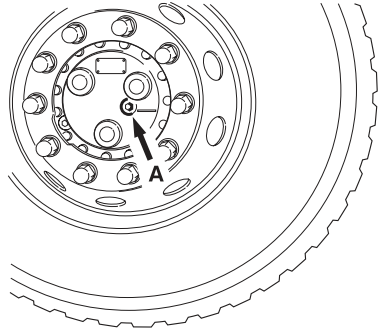

J1007657

### Front axle differential carrier

- 1 Clean around the level/filler plug (A).
- 2 Remove the level/filler plug (A), and check that the oil level reaches up to the edge of the filler hole.
- 3 Top up with oil as necessary.
- 4 Refit the level/filler plug (A).

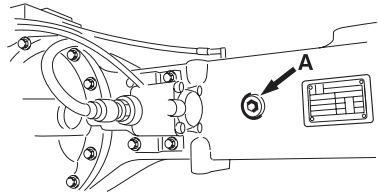

J1007658

If the filler plug has a sealing washer, the sealing washer must be replaced.

## Change oil

### Front axle wheel gears

- 1 Clean the connections for the drain plug (A) and the level/filler plug (B).
- 2 Position the wheel so that the drain plug (B) is at the bottom.
- 3 Remove the drain plug and drain the oil from the wheel gear housing. Remove also the level/filler plug (A) to facilitate draining.
- 4 Refit the drain plug (B). If the drain plug's sealing ring is damaged, it must be replaced.
- 5 Position the wheel so that the level mark by the level/filler hole (A) is horizontal.
- 6 Fill each wheel gear housing with new oil to the edge of the level hole.
- 7 Refit the level/filler plug (A). If the level/filler plug's sealing ring is damaged, it must be replaced.

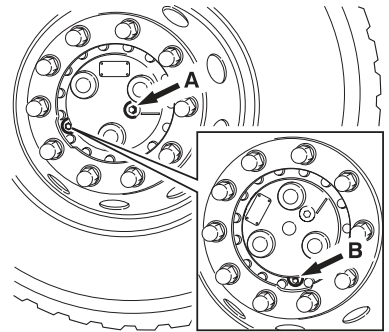

J1007659

The front axle must be raised

### Front axle differential carrier

- 1 Clean around the drain plug (B) and the level/filler plug (A).
- 2 Remove the drain plug (B) and drain the oil. Remove the level/filler plug (A).
- 3 Refit the drain plug (B). If the plug has a sealing washer, the sealing washer must be replaced.
- 4 Fill the differential carrier with new oil to the edge of the filler hole.
- 5 Refit the level/filler plug (A). If the plug has a sealing washer, the sealing washer must be replaced.

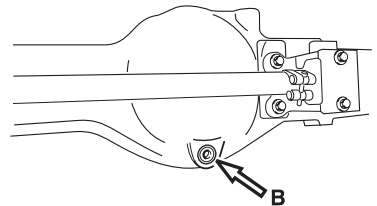

J4017902

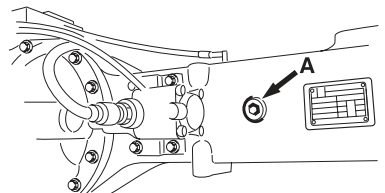

J1007658

## Flywheel mounted power take-off

Power take-off	Approximate change volume in litres
PTOFLY	5

### Oil grade

#### Transmission oil:

Volvo transmission oil 97305.

#### Engine oil:

API CE, CF or ACEA E2, E3.

### Viscosity

Viscosity is selected in accordance with the diagram:

1) For components without oil cooler that are run at a stable ambient temperature higher than +30°C.

Applies to engine oils: note that multi-grade oils SHALL NOT be used.

Components with an oil cooler can be run in an ambient temperature above +30°C when using oils SAE 80W-90 or SAE 40.

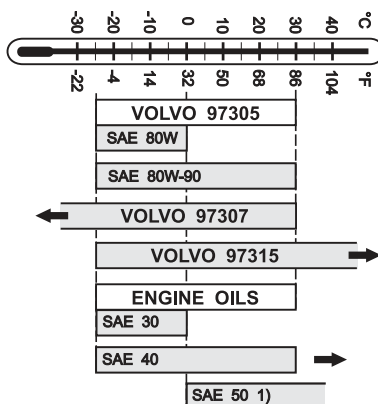

J1008789

### Service intervals

- First oil and filter change after 10,000 km or 4 weeks, whichever occurs first
- After the first oil and filter change, the oil should be changed every 120,000 km or every 12 months, whichever occurs first.

## Compact retarder

### Oil change volumes

Retarder		Oil volume, litre		
Volvo design	Voith design	Production filling	Service filling	Heat exchanger, completely drained from oil
RET-TH VR3250	VR 3250	6,1	5,4	6,1

In order to perform the service in a correct way, the type of retarder must be known. The information can be obtained by reading the type plate, see figure.

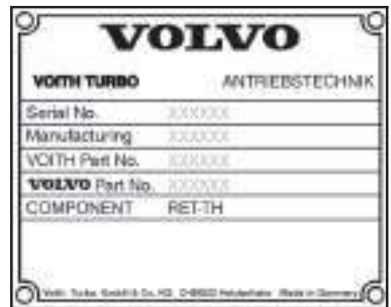

J5011336

### Note!

The name of the retarder is not marked on the type plate in some cases. In such cases the retarder is of type RET-RTH.

### Grade

Approved oils for use, see Voiths homepage:  
[http://www.voithturbo.de/vt\\_en\\_paa\\_road\\_retarder\\_service\\_oellist.htm](http://www.voithturbo.de/vt_en_paa_road_retarder_service_oellist.htm)

### Viscosity

Approved oils for use, see Voiths homepage:  
[http://www.voithturbo.de/vt\\_en\\_paa\\_road\\_retarder\\_service\\_oellist.htm](http://www.voithturbo.de/vt_en_paa_road_retarder_service_oellist.htm)

# 572 Maintenance

EOC (Engine Operating Condition )		L	M	H	S	VS	VS+
Model	Oil grade	km/max month					
RET-TH/ VR 3250	Voith Type A	120 000 / 24 <sup>1</sup>			60 000 / 24 <sup>1</sup>	45 000 / 24 <sup>1</sup>	
	Voith Type B	135 000 / 24 <sup>1</sup>			90 000 / 24 <sup>1</sup>	65 000 / 24 <sup>1</sup>	
	Voith Type C	180 000 / 24 <sup>1</sup>			135 000 / 24 <sup>1</sup>	90 000 / 24 <sup>1</sup>	
See information about applicable EOC definitions for each engine type, pages 7-23, Service bulletin 175-09, Lubrication service and oil change.							
Approved oils for use, see Voiths homepage: <a href="http://www.voithturbo.de/vt_en_paa_road_retarder_service_oellist.htm">http://www.voithturbo.de/vt_en_paa_road_retarder_service_oellist.htm</a>							
<sup>1</sup> Whichever occurs first.							

For Light/Medium/Heavy-applications where at least one of the following conditions apply, the service interval for Severe applications shall be used:

- use in areas with high ambient temperatures, such as in Saudi Arabia
- continuous driving at altitudes above 1500m above sea level
- continuous driving in extremely hilly topography
- use of the retarder in position 1–3 or B more than once per km
- use of the retarder in position 1–3 or B more than 10% of driving time

The service interval, repairs or inspected components are the same as for new components.

## Checking the oil level

The oil level in the retarder normally only needs to be checked when there is a problem with the retarder, such as low braking torque, oil leakage or in certain cases when an oil change has been done on the retarder. To ensure the correct oil level in the retarder, it is most suitable to perform the oil level check after driving, when the oil is hot. The vehicle must be standing horizontally.

### Warning!

The retarder must be disengaged when you check the oil level. Hot oil can otherwise be forced out from the retarder and cause burns. Use protective gloves.

### Note!

It is important for retarder function that the oil level is correct.

- 1 Clean around the drain plugs (C), oil filler plug (A) and breather plug (B).
- 2 Place a suitable vessel under the retarder to collect the oil.
- 3 Remove the drain plugs, the oil filler plug and the breather plug and let the oil run out of the retarder.
- 4 Check the sealing rings on the drain plugs. If they are damaged, the plugs must be replaced. Refit the drain plugs and tighten them to 16 Nm.
- 5 Measure the collected oil volume, if necessary correct it to the right oil volume, or refill the retarder with new oil measured to the right volume. For the correct oil change volume, see Oil change volumes. For the correct oil grade, see Oil grades.
- 6 Fill with oil through the filler hole. The filling time should be at least 3 minutes to allow the retarder system to ventilate through the breather passage.
- 7 Check the sealing ring on the oil filler plug. If it is damaged, the plug must be replaced. Refit the oil filler plug and tighten it to 50 Nm.

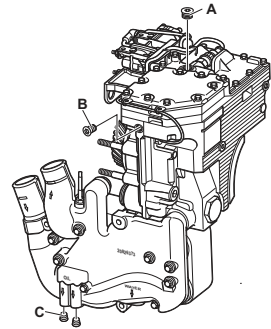

J206945



# 574 Maintenance

---

- 8 Check the sealing ring on the breather plug. If the sealing ring is damaged, replace it. Refit the breather plug and tighten it to 13 Nm.
- 9 After filling oil, drive with an approx. speed of 50 km/h. Engage the retarder 5 times in position 2 for about 5 seconds each time. Most suitably done in connection with road test.

## Oil change

### Oil change volume:

5.4 litres.

Oil change is best done immediately after driving when the oil is hot and has lower viscosity.

Use oil according to “Oil recommendations”

The vehicle must be standing horizontally.



### Warning!

The retarder must be disengaged when changing oil. Hot oil can otherwise be forced out of the retarder and cause burn injuries. Wear protective gloves.

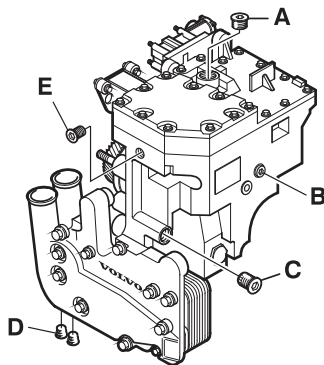

J0008610

- 1 Remove any sound baffles from under the gearbox.
- 2 Clean around the drain plugs (D), filler plug (A) and breather plug (E).
- 3 Remove the drain plugs (D), filler plug (A) and breather plug (E) and let the oil run out of the retarder.
- 4 Clean around the plug (C) and remove the plug with strainer.
- 5 Wash and blow clean the strainer in the plug (C) with compressed air.
- 6 Refit the plug (C) with strainer. If the sealing ring is damaged, replace it. Torque tighten the plug to 100 Nm.
- 7 Refit the drain plugs (D). If the sealing rings are damaged, they must be replaced. Torque tighten the plugs to 20 Nm.
- 8 Fill the retarder with exactly the correct amount of oil. Pour the oil carefully into the filler hole (A). The filling time should be at least 3 minutes to allow the retarder system to ventilate through the breather passage (E).
- 9 Refit the filler plug (A). If the sealing ring is damaged, it must be replaced. Torque tighten the plug to 50 Nm.
- 10 Refit the breather plug (E). If the sealing ring is damaged, it must be replaced. Torque tighten the plug to 13 Nm.
- 11 Check-tighten the retarder's top cover screws according to the tightening diagram. Tightening torque 30 Nm. Applies only to the first retarder oil change.
- 12 Refit any sound baffles under the gearbox.

## Note!

After the oil change, drive at about 50 km/h. Apply the retarder 5 times in position 2 for about 5 seconds each time. This is done most suitably when road testing.

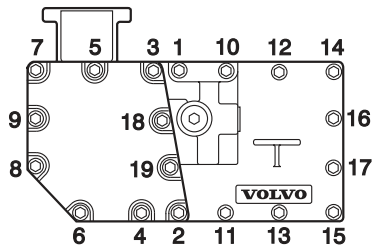

J0008979

Tightening diagram

## Air drier, general

The purpose of the air drier is to dry and clean the compressed air from moisture and oil, which could otherwise cause malfunctions. The air drier is

regenerated (dried) by allowing a certain amount of the pumped air to flow back through the drier. The system pressure drops during this process. If the compressor has pumped a large amount of air, the compressor may start up again before the required amount of air has flowed back. This will result in a number of compressor charging and regeneration phases in sequence, until the required amount of air has flowed back. **This is quite normal.**

## Checking the air drier

Drain the primary and circuit tanks at least once a week, or when the symbol for moisture is displayed. If any of the tanks contain water, the desiccant must be replaced and the air drier checked at a Volvo workshop.

The desiccant in the braking system shall be replaced every other year or when the symbol for replacement of desiccant is displayed. If this function is not activated, the replacement interval is every 12 months.

Use only Volvo original desiccant inserts, which have a built-in oil filter .

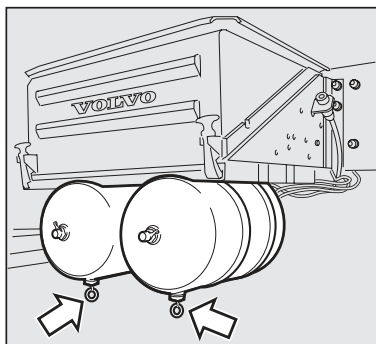

J5012263



J5013654

The symbol has several meanings, see section Display. In order to find out why the symbol is lit, look up the fault message in the display diagnostic menu.

### **Note!**

Do not use frost protection (alcohol) in trucks with air driers.

## Charging with air from an external compressed air source

Always use the test nipple on the air drier. Charging with air in any other way may allow moisture to enter into the system.

The test nipple and the air drier are located in the wheel housing on the passenger side.

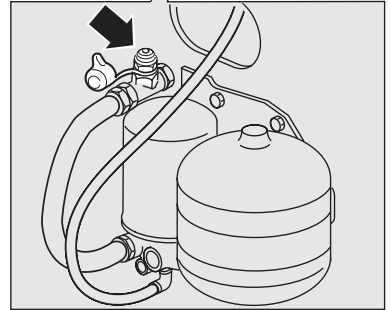
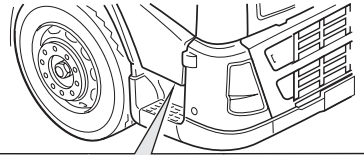

J0010459

Tilt the cab to access the test nipple.

## Brake lining

Each brake caliper is fitted with an electric wear sensor that shows the average thickness of both brake linings. A yellow warning lamp will come on and an error code will be set when only 20% of the brake linings is remaining. The brake pads must then be replaced. Brake lining wear can also be read using the wear pin on the brake caliper. The line on the measuring pin indicates the amount of outer brake lining that is left. The marks correspond to 25, 50, 75 and 100 percent of lining thickness. When the linings are new, 20 mm of the wear pin is visible. When 4 mm of the wear pin is visible then the lining is approximately 4 mm thick; worn out. Replace brake pads on both wheels on the same axle at the same time. The electric wear sensor must be recalibrated at a Volvo garage after the brake pads have been changed.

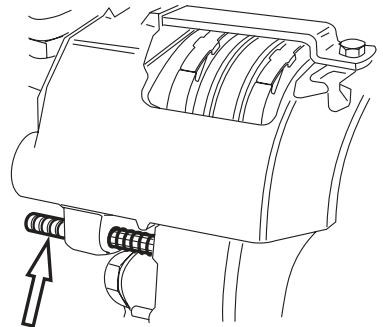

J5011012

## Note!

Brake lining wear can also be read using the wear pin on the brake caliper at every basic service, as a complement to the electronic sensor.

## Servo steering

### Oil recommendations

	Oil grade	Oil volume	Oil change	Filter change
Servo steering PSS-SING PSS-DUAL	ATF oil, type Dexron III	approx. 5.0 litres approx. 9.0 litres	Only in connection with repairs.	Once per year.
Steering system, hydraulically steered pusher axle and hydraulically steered trailing wheel axle	ATF oil, type Dexron III	approx. 6.0 litres	Only in connection with repairs	

### Checking the oil level

- 1 Clean around the cap and dipstick
- 2 Check the oil level. With the engine stationary, the level should be on the MAX marking on the dipstick
- 3 Top up with oil as necessary

Some trucks with 2-circuit steering systems have twin oil reservoirs for the servo steering.



J0008138

## Replacing filter

Change oil immediately after carrying out repairs.

- 1 Clean round the cap and the dipstick before the cap is removed
- 2 Press down and unscrew the locking device for the filter
- 3 Lift up the old filter and keep one finger under the filter's centre hole, so that impurities from inside the filter do not enter the oil reservoir
- 4 Transfer the locking device to the new filter and insert it into the oil reservoir
- 5 Check that the filter is positioned correctly and is locked in place securely
- 6 Check the oil level and top up with oil to the MAX marking
- 7 Fit the cover



## Hydraulic pusher axle and trailing wheel axle

### Checking the oil level

- 1 Clean around the cap and dipstick
- 2 Unplug the connector on the electrical cable to the dipstick. Check the oil level. With the engine stationary, the level should be on the MAX marking on the dipstick
- 3 Top up with oil as necessary

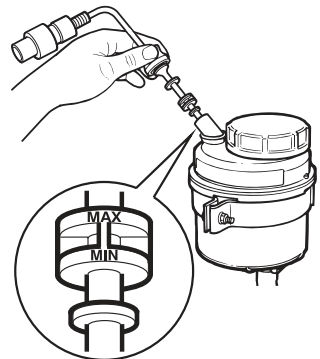

## Rear axle

### Oil recommendations

On vehicles with single gear, the oil is filled up to the edge of the level hole.

On vehicles with hub reduction, the hub is first filled with oil in accordance with the table above. The differential is then filled with oil up to the edge of the level hole.

For a number of reasons not all rear axles can have the same service recommendations. They have therefore been divided into service categories.

The service categories, numbers or letters, can be found on the ID plate on the final drive. The categories are G, 1 and 2.

Two different service recommendations can be applied to rear axles:

- Standard service recommendation
- Alternative service recommendation

The alternative service recommendation provides longer service intervals than standard service recommendation. The alternative service recommendation demands the use of special oil.

The standard service recommendation and alternative service recommendation both consist of three parts. The three parts are oil grade, viscosity and service intervals. These can be found in the same order on the following pages.

The following procedure can be very useful when deciding which oil to use.

- 1 Find out which service category the component belongs to
- 2 Use the information in the table under Service intervals and decide which service recommendation will be used

### Note!

If the rear axle has no entry under service category on the ID plate, it belongs to service category G.

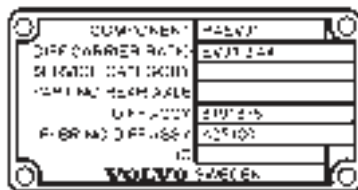

J1006943

3 Use the information under Oil grade and Viscosity to determine which oil to use

Rear axle	Approximate change volume in litres		
	Final drive	Every hub	Total
RAEV80	12		12
RSS1344B	12,5		12,5
RS1356SV Leaf springs	8,5		8,5
RS1356SV Air suspension	9		9
RS1352HV <sup>1</sup>	19	1,5	22
RS1352HV Leaf springs	20	3	26
RS1352HV Air suspension	16	3	22
RS1365HV	22	3	28
RS1370HV <sup>1</sup>	19	1,5	22
RS1370HV Leaf springs	20	3	26
RS1370HV Air suspension	16	3	22
RSH1370C (S5 hub)	17,3	0,6	18,5
CTEV87 (front axle) Leaf springs	20		20
CTEV87 (rear axle) Leaf springs	9		9
CTEV87 (front axle) Air suspension	16		16

<sup>1</sup> Oil volume 1.5 litre only for hub reduction casings with part number 1524851 or 1524852. This marking can be seen on the hub reduction casings.



# 582 Maintenance

Rear axle	Approximate change volume in litres		
	Final drive	Every hub	Total
CTEV87 (rear axle) Air suspension	7,5		7,5
CTN372 (front axle)	26,5	3	32,5
CTN372 (rear axle)	23,5	3	29,5
CTN372, BGT32TR (front axle)	22	3	28
CTN372, BGT32TR (rear axle)	20	3	26
CTN472 (front axle)	28	3	34
CTN472 (rear axle)	25	3	31
RT2610HV (front axle) Leaf springs	23	3	29
RT2610HV (rear axle) Leaf springs	19	3	25
RT2610HV (front axle) Air suspension	23	3	29
RT2610HV (rear axle) Air suspension	19	3	25
RT3210HV (front axle) <sup>1</sup>	22,5	1,5	25,5

<sup>1</sup> Oil volume 1.5 litre only for hub reduction casings with part number 1524851 or 1524852. This marking can be seen on the hub reduction casings.

Rear axle	Approximate change volume in litres		
	Final drive	Every hub	Total
RT3210HV (front axle) Leaf springs	22,5	3	28
RT3210HV (rear axle) <sup>1</sup>	1,8	1,5	21,5
RT3210HV (rear axle) Leaf springs	18,5	3	24
RTH2610B (front axle) Leaf springs	23	3	30
RTH2610B (rear axle) Leaf springs	19	3	26
RTS2370A (front axle)	20		20
RTS2370A (rear axle)	14		14

<sup>1</sup> Oil volume 1.5 litre only for hub reduction casings with part number 1524851 or 1524852. This marking can be seen on the hub reduction casings.

## Oil grade

- 1 SAE J 2360 or APL GL-5
- 2 Volvo Transmission oil 97312

## Note!

The choice of oil grade affects the service interval; see the table.

## Viscosity

Viscosity is selected in accordance with the diagram. Temperatures refer to constant ambient temperatures.

- 1) When driving in severe conditions or frequently driving in very hilly road conditions, SAE 80W-140, SAE 85W-140 or SAE 140 are recommended
- 2) SAE 90 may not be used in rear axle RAN281

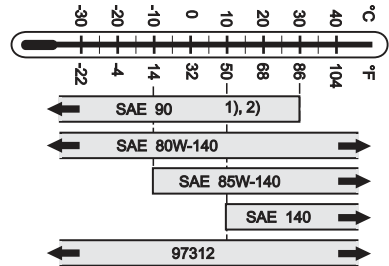

J1008788

## Note!

SAE 80W/90 must not be used.

## Service interval

The service category of the rear axle is dependant on where the vehicle was manufactured. In some markets there can be vehicles with rear axles belonging to different service categories, and in these cases special care must be taken when planning the first oil change.

Service category	Interval
Service categories 1 and G	First oil change after 10 000 km or 4 weeks, whichever occurs first.
Service category 2	First oil and oil filter change after 400 000 km or three years, whichever occurs first.

Oil grade	Service category	
	G	1 and 2
	Oil change interval (km)	
<sup>1</sup> This recommendation is not applicable to RAN281.		

Oil grade	Service category	
API GL-5 and/or SAE J2360	120 000/12 months	120 000/12 months
Volvo Transmission oil 97312	180,000/12 months <sup>1</sup>	400,000/36 months
<sup>1</sup> This recommendation is not applicable to RAN281.		

- With construction site driving in extremely hilly conditions the oil shall be changed after 2500 driving hours when using transmission oil 97312, and after max 600 driving hours when using any other oil
- For vehicles with hub reduction axles which are frequently driven at more than 90 km/h the service interval shall be halved
- If the total weight for the combination exceeds 80 ton and the ambient temperature is above 30°C for more than 1 month per year, the oil change intervals shall be halved

### When replenishing oil level in rear axle

When the oil level in a rear axle is too low, it must be topped up with oil. The following then applies:

- If the same oil is used to top up the rear axle as the one already in the rear axle, there is no limit to how much oil can be filled or how many times the oil level can be replenished
- If approved oil other than the one already in the rear axle is used for topping up, then no more than one litre may be used. This applies regardless of how many times the oil is topped up to the correct level. If more oil needs to be added, carry out a complete oil change instead

## Check the oil level

If there is any oil leakage from the rear axle and/or hub reduction hubs, or if there is any doubt about the rear axle oil level, check as follows:

If there is a bogie, it must be lowered.

- 1 Clean around the level plug/filler plug (1)
- 2 Remove the level/filler plug (1) and check that the oil level reaches up to the edge of the filling hole
- 3 Top up with oil as necessary
- 4 Install the level/filler plug (1)

If the filler plug has a seal washer, the seal washer must be changed.

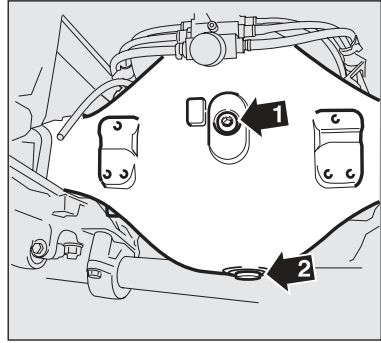

J4017799

- 1 Level/filler plug
- 2 Drain plug

## Change oil

Drain the oil immediately after driving. Then it has low viscosity.

Drain the oil by unscrewing the drain plug in the rear axle casing. Replace the sealing if it is damaged.

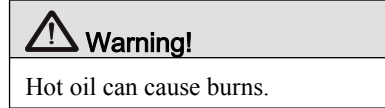

**Warning!**

Hot oil can cause burns.

## Note!

If the vehicle has a rear axle with hub reduction, the hubs must be drained separately, see “Rear axle with hub reduction”.

**Note!**

Oil can run down to the anti-roll bar and spread out. Use a large vessel to collect the oil. Place a piece of sheet metal between the rear axle and the anti-roll bar that the oil can run on to when draining the rear axle. Clean the anti-roll bar after the oil change if oil has run onto it.

## Rear axle with hub reduction

**Change oil in the hub**

Fill each hub first and then fill the remaining oil into the rear axle casing. See “Oil recommendations” for the correct oil volume.

The level mark must be horizontal when checking the oil.

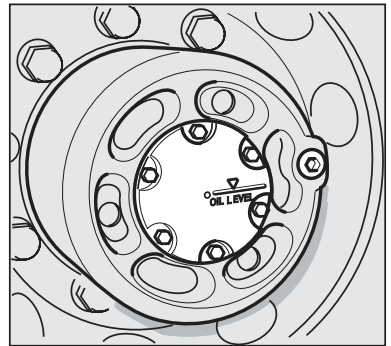

J4017800

The plug (1) must be in its lowest position when oil is being drained.

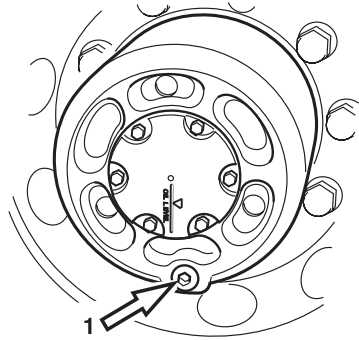

J1007412

## Tyres

### Some advice on avoiding unnecessary tyre wear

- Keep the correct air pressure, not too high and not too low
- Remember that wear increases with speed
- Do not exert excess pressure on the tyres with uneven loads
- Do not drive with imbalanced tyres
- Check front wheel toe-in regularly
- Do not shift tyres unnecessarily

### Single drive wheels

Trucks with single tyres on the driving axle shall be equipped with tyre pressure monitoring (TPM) and electronic stability program (ESP). TPM warns the driver if a tyre is leaking air, which could cause the tyre to explode due to overheating. If an explosion should occur, ESP provides an important function and helps the driver keep control of the truck. From a safety point of view, it is important that these systems function correctly. If a fault in ESP, the braking

system or TPM is indicated, drive carefully with reduced speed, especially on curves. The speed should not exceed 60km/h. Lower the speed even further in sharp curves. Rectify the fault as soon as possible.

## Dual wheels

Use only tyres of the same type on dual mounted wheels. The tyres may have max. 6 mm difference in diameter.

## Checking tyre pressure

Check the tyre pressures when refueling, or at least every fortnight. Suit the pressures to the type of truck and axle load, not to the technical maximum load. Remember to also check the pressure in the spare tyre occasionally.

## Recommended tyre pressures

**Follow the tyre manufacturer's recommendations.**

If there is no recommendation, a temporary solution is to use the tyre pressures in the diagram below.

### Note!

The tyre pressures in the diagram below are taken from ETRTO's (European Tyre and Rim Technical Organisation) standard manual. All the larger tyre manufacturers are members of ETRTO and use the standard manual as a guide.



# 590 Maintenance

Dual mounting

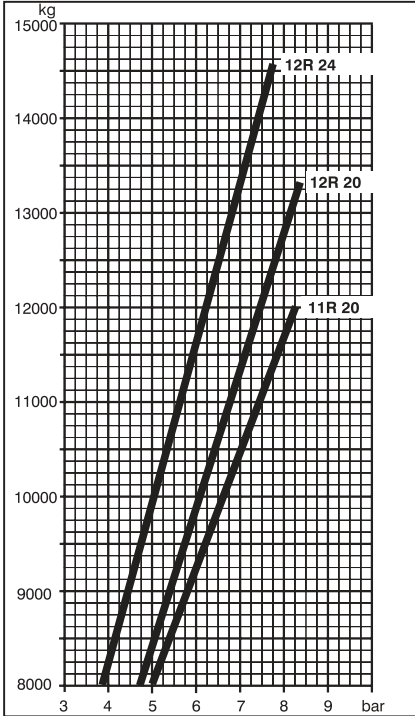

Single mounting

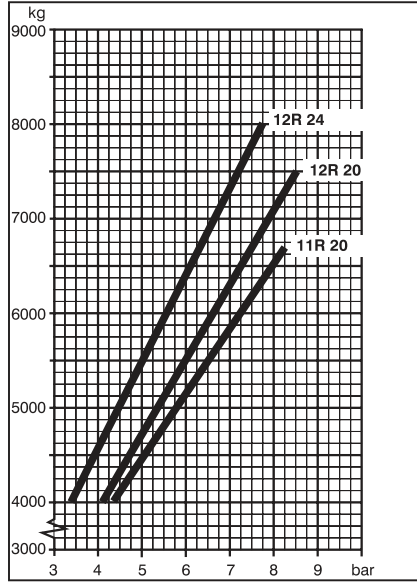

Dual mounting

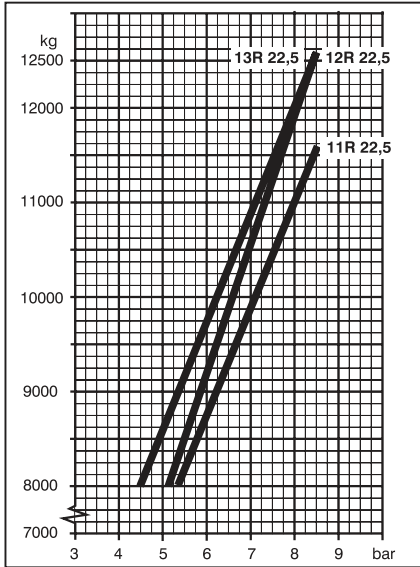

Single mounting

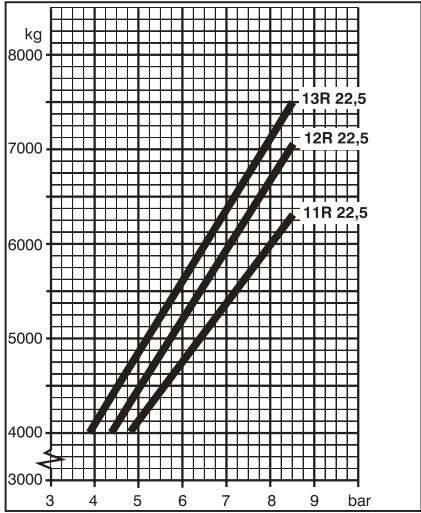

# 592 Maintenance

Dual mounting

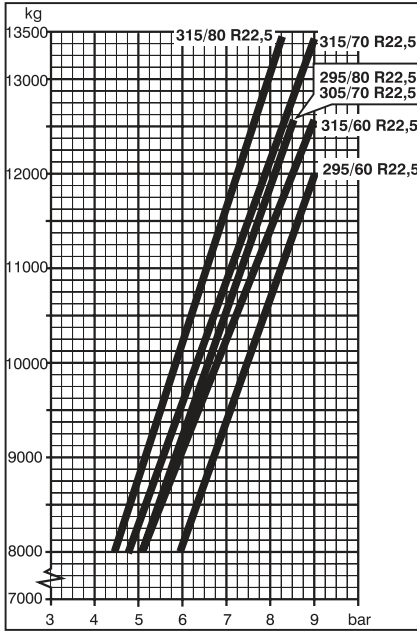

Single mounting

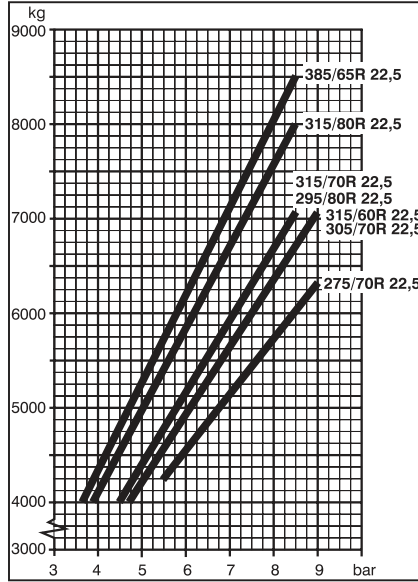

## Changing wheels

### Removing the wheel

- 1 Chock the wheel that is to remain on the ground
- 2 Ensure that the brake is not applied to the wheel that is to be removed
- 3 Place the jack under the axle, as close to the wheel as possible
- 4 Undo the wheel nuts a couple of turns
- 5 Lift the truck so that the wheel loses contact with the ground (Lift one side at a time.)
- 6 Remove the wheel nuts completely
- 7 Lift off the wheel



#### **Warning!**

Never crawl under the vehicle while it is raised on a jack!

Place the jack on a solid, horizontal and non-slippery surface!

Chock the wheels that are to remain on the ground with substantial wooden blocks or large stones. Chock both in front of and behind the wheel

Release the brake on the wheel that is to be removed

#### **Note!**

The jack shall not press against the shock absorber bracket or the anti-roll bar bracket.

### Fit the wheel

#### **Note!**

Always use wheel bolts and wheel nuts intended for the type of wheel. Different types of wheel require different types of wheel bolts and wheel nuts.

## Disc wheel

- 1 Clean and lubricate the wheel bolt threads with oil only
- 2 Clean the contact surfaces of the wheel, brake drum and hub
- 3 Release the brakes (Otherwise the brake drum can become oval.)
- 4 Torque tighten the wheel nuts to  $200 \pm 8$  Nm. Tightening sequence according to illustration
- 5 After torque tightening, angle tighten the wheel nuts  $90^\circ \pm 10^\circ$ . Tightening sequence according to illustration. Check-tighten the wheel nuts after driving the vehicle a short distance (approx. 200 km)

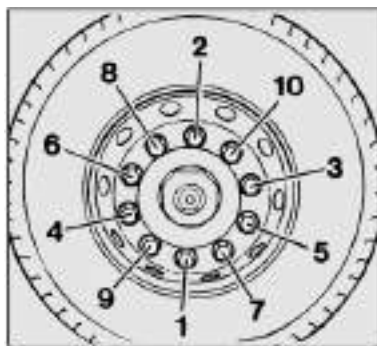

J0008154

Tightening order, disc wheels

### Note!

If the torque when re-tightening is less than 670 Nm on any of the wheel nuts, then all the wheel nuts must be released and then be torque-tightened and angle tightened according to the tightening sequence. **Every 6 months:** Check and re-tighten all wheel nuts irrespective of whether the wheel has been removed or not.

### Note!

Note that the size of the wheel bolts is M22x1.5, and not 7/8"-14 with a UNF thread as on older Volvo models.

## Spoked wheel, single wheel

- 1 Clean and lubricate the wheel bolt threads with oil only.
- 2 Clean the contact surface of the wheel and spoked hub
- 3 Lift the wheel onto the hub. Make sure the valve and both stops on the wheel rim are positioned between two spokes
- 4 Fit two clamp shoes and nuts opposite each other
- 5 Gently tighten the nuts so that the wheel is centred
- 6 Fit the remaining clamp shoes and nuts
- 7 Torque-tighten the nuts in steps to tightening torque  $330 \pm 30$  Nm. Tightening sequence as illustrated
- 8 Retighten the nuts to 330 Nm after driving the vehicle a short distance (approx. 200 km)

**Every 6 months:** Check and re-tighten all wheel nuts irrespective of whether the wheel has been removed or not.

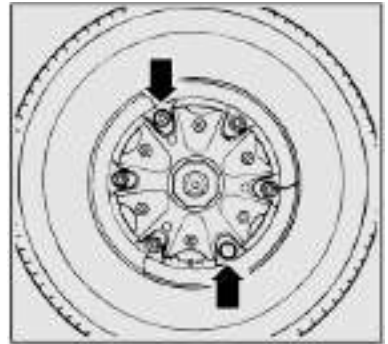

J0008155

Single wheel, centring

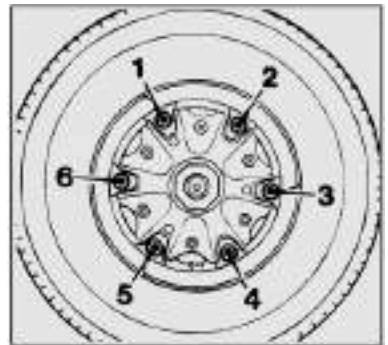

J0008156

Tightening order, spoke wheels

## Spoked wheels, double wheels

- 1 Clean and lubricate the wheel bolt threads with oil only.
- 2 Clean the contact surface of the wheel and spoked hub
- 3 Fit the inboard wheel so that the valve and both stops on the wheel rim are positioned between two spokes (see figure)
- 4 Push on the spacer ring so that it is tight against the inboard wheel rim. The spacer ring stop must be placed between two spokes. Make sure the stop does not obscure the valve on the inboard tyre and the centring heels of the spacer ring are on top of the spokes (see figure)
- 5 Lift the outboard wheel and press it against the spacer ring. Make sure the valve on the outboard tyre is located diagonally opposite the one on the inboard tyre. Fit both upper clamps shoes and nuts. Tighten the nuts enough to centre the wheel
- 6 Fit the remaining clamps and nuts. Tighten the nuts in the correct order around the edge of the wheel rim. Torque-tighten the nuts in steps according to the illustration to  $330 \pm 30$  Nm. Tightening sequence as illustrated
- 7 Retighten the wheel nuts to 330 Nm after driving the vehicle a short distance (approx. 200 km)  
**Every 6 months:** Check and re-tighten all wheel nuts irrespective of whether the wheel has been removed or not.

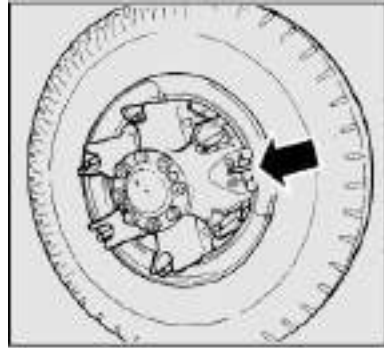

J0008177

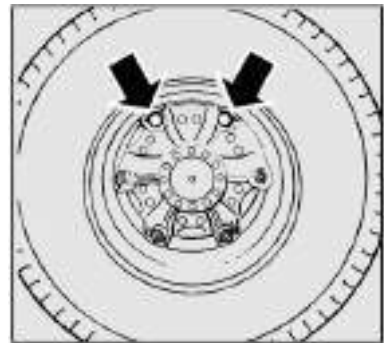

J0008157

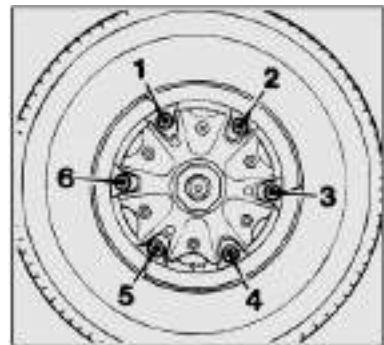

J0008156

## Changing front wheel on a fully air suspended truck

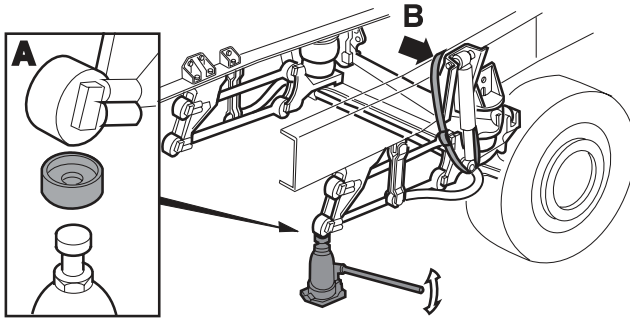

J0007843

- 1 Put the starter key in drive position
- 2 Lock the wheels which will be left on the ground.  
Use chocks, heavy blocks of wood or large stones
- 3 Take the jack out
- 4 Tilt the cab
- 5 Lift the front of the chassis by means of the air suspension so that the jack fits exactly under the front reaction rod (A)
- 6 Lower the front suspension as far as possible with the air suspension
- 7 Set the starter key in stop position
- 8 Put the control switch (the top one on the control box) in the centre position
- 9 Take out the load retention strap
- 10 Tighten the load retention strap around the anti-roll bar and chassis (B)
- 11 Loosen the wheel nuts (several turns)
- 12 Lift up the truck with a jack
- 13 Put a block of wood underneath the front axle
- 14 Remove the wheel
- 15 Install the spare wheel



- 16 Remove the block of wood from under the front axle
- 17 Lower the jack
- 18 Remove the load retention strap
- 19 Put the starter key in drive position
- 20 Raise the vehicle with the air suspension
- 21 Remove the jack
- 22 Tighten the wheel nuts
- 23 Lower the cab
- 24 Remove the chocks

## Removing a wheel on all wheel drive truck

### Raising the front axle on all wheel drive trucks

- 1 Chock the wheel that is to remain on the ground
- 2 Ensure that the brake is not applied to the wheel that is to be removed
- 3 Undo the wheel nuts a couple of turns
- 4 Take out the wooden blocks that are kept in the cab
- 5 Put the large wooden block under the spring unit attachment to the front axle casing
- 6 Place the jack on the wooden block
- 7 Screw up the jack until it makes contact with the axle casing
- 8 Lift the front axle up using the jack
- 9 Place the other wooden block standing upright on the horizontal wooden block
- 10 Lower the axle so the axle casing rests on the standing wooden block
- 11 Lower the jack's hydraulic piston
- 12 Screw up the jack until it makes contact with the axle casing
- 13 Raise the axle with the jack so that the wheel is free from the ground

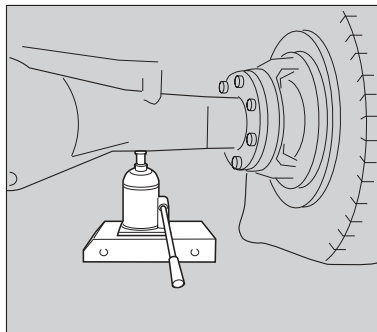

J7009728

- 14 Leave the standing wooden block in place until the spare wheel is fitted
- 15 Remove the wheel bolts completely
- 16 Lift off the wheel

Lower the axle by first lowering it onto the standing wooden block. Then screw down the adjustable part of the jack and lift the axle sufficiently to remove the standing wooden block. Lower the axle completely.

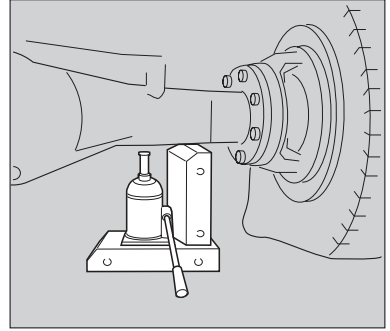

J7009730

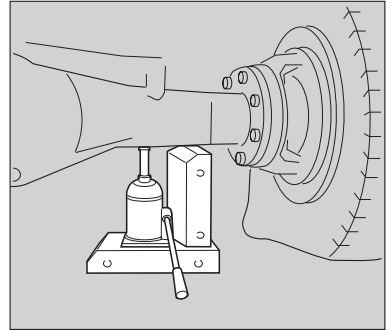

J7009729

### Raising the rear axle on all wheel drive trucks

- 1 Chock the wheel that is to remain on the ground
- 2 Ensure that the brake is not applied to the wheel that is to be removed
- 3 Undo the wheel nuts a couple of turns
- 4 Take out the wooden blocks that are kept in the cab
- 5 Place the jack under the rear axle
- 6 Screw up the jack until it makes contact with the axle casing
- 7 Raise the rear axle with the jack
- 8 Put the large wooden block under the axle casing
- 9 Lower the axle so the axle casing rests on the standing wooden block

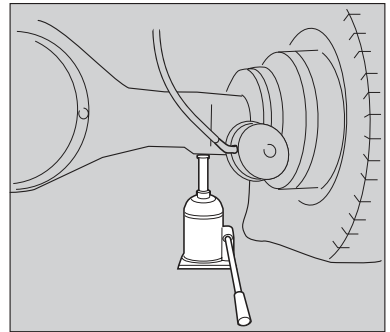

J7009731

# 600 Maintenance

- 10 Lower the jack's hydraulic piston
- 11 Screw down the adjustable part of the jack
- 12 Place the other wooden block under the axle casing
- 13 Place the jack on the wooden block
- 14 Screw up the jack's adjustable part until it makes contact with the support surface under the axle
- 15 Raise the axle with the jack so that the wheel is free from the ground
- 16 Leave the standing wooden block in place until the spare wheel is fitted
- 17 Remove the wheel bolts completely
- 18 Lift off the wheel

Lower the axle by first lowering it onto the standing wooden block. Remove the lying wooden block. Then screw up the adjustable part of the jack and lift the axle sufficiently to remove the standing wooden block. Lower the axle completely.

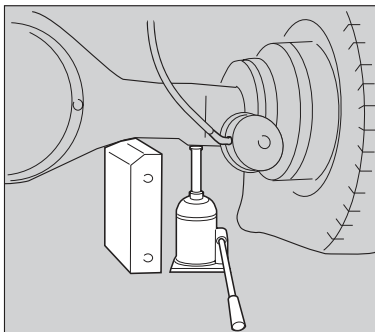

J7009732

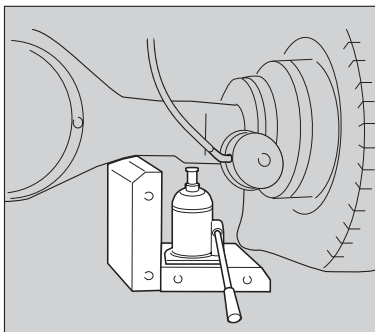

J7009733

## Disc wheel for disc brakes

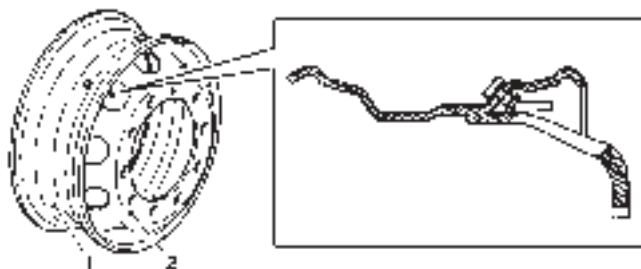

- 1 Rim
- 2 Disc

J7008363

The wheel can also be used on vehicles with drum brakes.

 **Caution!**

Use only disc wheels with exterior valve location on vehicles with disc brakes.

## Painting rims

 **Caution!**

Protect the mating surfaces between the hub and brake drum when painting to keep them free from paint.

**Disc wheels:** Only primer and original finishing paint is allowed on the wheel mating surfaces, both on the outside and the inside. There is a risk of the wheel nuts coming loose if the paint layer is too thick.

**Spoke wheels:** The sloping top of the spokes must be completely free from paint, etc.

## Spare wheel in Combi-box

- 1 Tension the wheel in place with the tensioning band
- 2 Fit the lever from the jack in the lever arm  
Press the lever arm down as far as it will go
- 3 Fix the lever arm with the wingnut

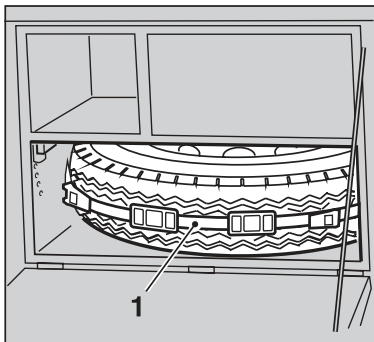

J7009509

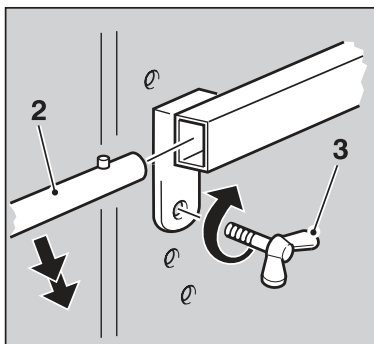

J7009510

## Snow chains

Snow chains on the front axle should if possible be placed on the passenger side. On the drivers side, there is a risk that snow chains will damage the link rod.

## Hydraulic bogie lift

### Oil recommendations

	Oil grade	Oil volume	Oil change
Bogie lift	Hydraulic oil BLV or oil that fulfills Standard MIL-H-5606F.	5.5 litres	Once per year.

### Checking the oil level

The bogie must be lowered and the bogie lift operated to the end position.

- 1 Check that the oil level is between the markings on the oil reservoir
- 2 Top up with oil as necessary

### Changing oil

Drain the oil through the bottom plug (A). Refit the plug and fill with oil.

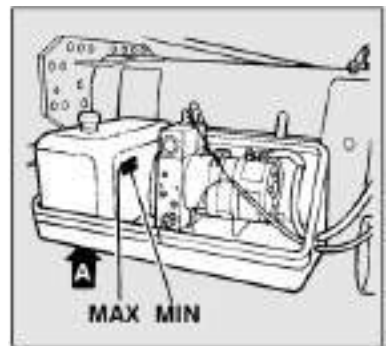

J0008137

## Bodywork

### Oil recommendations

Refer to the body builder's information for oil recommendations and oil changes and for other information about how the bodywork functions. Be careful not to mix different types of hydraulic oil without first having cleaned the hydraulic system or after having asked the supplier of hydraulic oil for advice.

## Cab tilt pump

### Oil recommendations

	Oil grade	Oil change
Cab tilt pump	Hydraulic oil BLV	Only in connection with repairs.

### Checking the oil level

Check the oil level with the cab in the driving position.

- 1 To check the oil level in the cab tilt pump, the panel in front of the foot step must be removed
- 2 Place the pump rod for the cab tilt pump in its rearmost position
- 3 Check that the oil level for the cab tilt pump is in the centre of the level glass (B)
- 4 Top up with oil as necessary. Filler plug at (A)

The oil only needs to be changed in connection with repairs.

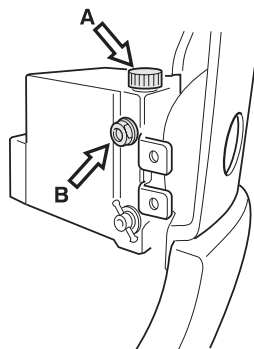

J1007364

## Central lubrication

The central lubrication provides automatic lubrication, which would otherwise be done at service intervals. The advantages of this is that you get a more even lubrication at all locations and the service occasions are fewer.

The lubrication takes place during driving at 9 hour intervals. The lubrication is also activated if the vehicle has been stationary for more than 48 hours.

### Manual lubrication

The central lubrication can be activated manually with a switch under the pump's plastic cover on the main unit.

If in doubt of the function of the central lubrication, check the fuse and do manual lubrication.

- 1 Start the engine.
- 2 Press in the switch under the plastic cover on the central lubrication's main unit.
- 3 The pump motor should now run for approx. 2 minutes.

## Replenishing lubricant

**Important!** It is extremely important to use the correct equipment and quality of grease when replenishing to avoid dirt getting into the system. Filling up is done via the nipple, under the pump's plastic casing on the central unit, with the tool intended for this.

**Filling intervals:** every six months or when the grease level has decreased to the "MIN" mark

**Grease consistency:** NLGI 00 or NLGI 000 (For more information about approved greases, contact an authorised Volvo dealer.)

### System volume:

Tractor: approx. 2.7 kg

Others: approx. 6 kg

## Changing air filter for air conditioning system

Change air filter every 12 months. Never shake or brush clean the filter if it becomes fouled any earlier. Never wash the filter.

- 1 Unscrew the filter retainer
- 2 Dismantle the filter retainer
- 3 Discard the old filter
- 4 Clean the filter retainer
- 5 Fit the new filter
- 6 Assemble the filter retainer
- 7 Refit and screw on the filter retainer

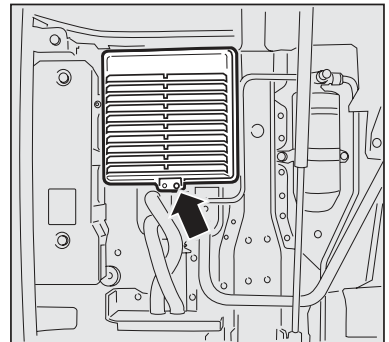

J8008460



## Refrigerant



### Caution!

Refrigerant is a health hazard.  
The air conditioning system may only be serviced by authorised personnel.

## Parking heater

- Check that the combustion air and exhaust openings are not blocked
- Check that the heater fuel pipes are carefully installed and clamped
- To avoid harmful deposits, the heater should be started once a month, even in summer, and should then be allowed to run for 15 minutes. Do not forget to set the thermostat and heat controls
- When the coolant is changed or topped up, the engine must be warmed up until the thermostat opens and the cooling system has been vented before the heater can be started. If the heater is started too early, there is a risk that the overheating guard in the heater could be tripped
- Perform an annual check of the heater in good time before the winter season starts. Contact your Volvo workshop

## Chassis lubrication

Chassis lubrication includes the lubrication of all grease nipples using a grease gun and check or change of oils.

### Note!

Always make sure each grease point is well lubricated. Grease until new grease is forced out and becomes visible. If no grease forces its way out there is something wrong and action must be taken immediately.

## Cab lubrication

Lubrication points	Lubricant
1 Lock and hinge	Grease, oil
2 Top footstep	Oil
3 Lower footstep	Oil
4 Door stop	Grease
5 Key hole	Lock oil
6 Striker plate, lock lug	Paraffin
7 Locks, baggage hatches	Paraffin
8 Cab lock	Grease

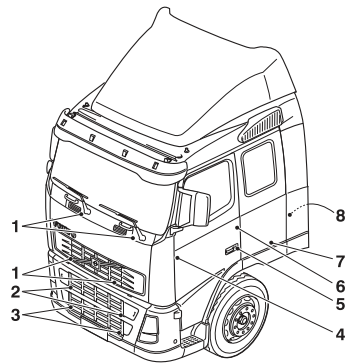

J1007404

## Symbols

- 1 Engine oil
- 2 Gearbox oil or engine oil
- 3 Rear axle oil
- 4 ATF oil
- 5 Hydraulic oil
- 6 Brake fluid or clutch fluid
- 7 Lubricating grease

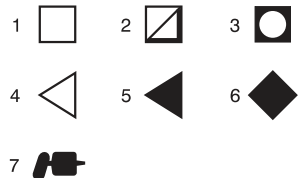

J1006475

## Grease quality

Lithium based grease with EP additives and of consistency NLGI no. 2. Check the following fluid levels in connection with lubrication service:

- batteries
- cooling system
- washer reservoirs

## 4x2, 6x2, 8x2 vehicles with hydraulically controlled bogies

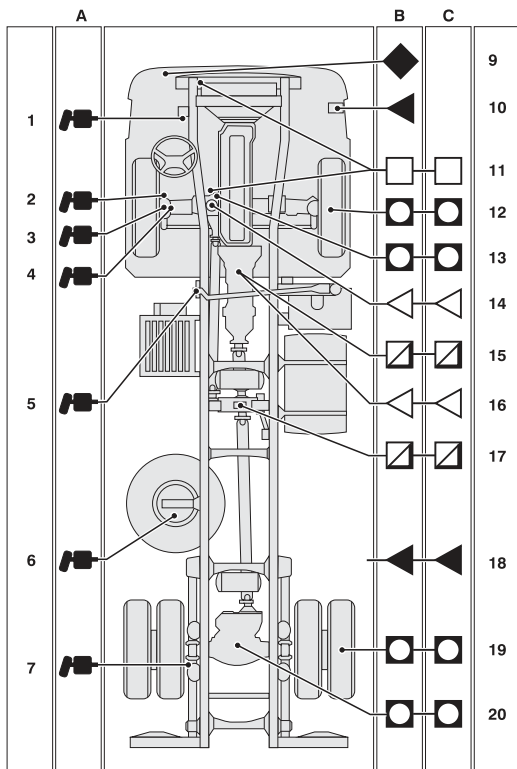

J1007420

**A=Lubrication points**

**B=Fluid level check**

## C=Oil change and filter change

- 1 Brake cam (one on each wheel, not included on disc brakes)
- 2 Steering arm, 8x2 and 8x4
- 3 Spare wheel holder
- 4 Spring anchorage (2 pcs for 6x2 and 8x2)
- 5 Cylinder, bogie lift (2 pcs)
- 6 Axle, bogie lift (4 pcs)
- 7 Roller, balance arms (2 pcs)
- 8 Roller, bogie lift
- 9 Balance arms (6 pcs).  
First, grease the grease nipple in the centre until grease is forced out by the sealing ring or the overflow hole. Then grease both the other grease nipples until grease is forced out.
- 10 Cradle (2 pcs, not included on air suspension).  
Grease until grease is forced out.
- 11 Clutch fluid reservoir
- 12 Pump for cab tilt
- 13 Motor
- 14 Steering servo reservoir
- 15 Steering servo reservoir for dual servo systems (certain versions of 8x2 and 8x4)
- 16 Manual gearbox
- 17 Automatic gearbox
- 18 Hydraulic oil tank (some variants)
- 19 Rear axle (2 pcs for 6x4 and 8x4)
- 20 Bogie lift (must be lowered when changing oil or checking oil level)

The parking brake must be released when lubricating so that grease can be forced in properly to the brake cams. (Applies to vehicles with drum brakes.) Chock a wheel with wooden blocks or similar, so that the vehicle cannot start moving during service work.

# 610 Maintenance

Besides the lubrication points in the lubrication scheme, the joints for controls and levers should regularly be lubricated with thin engine oil.

## Rear assembly 6X4, 8X4

**A=Lubrication points**

**B=Fluid level check**

**C=Oil and filter change**

- 1 Brake cam (one on each wheel, not included on disc brakes)
- 10 Cradle (2 pcs, not included on air suspension and not for RADD-BR with RSH-STD or RSH-HIG).  
Lubricate until grease is forced out.
- 19 Rear axle (2 pcs for 6x4 and 8x4)

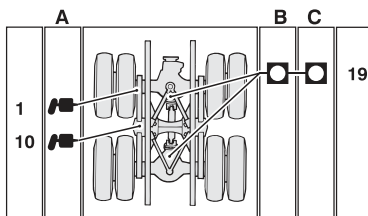

J1008539

## Rear assembly, hydraulically steered pusher axle

**A=Lubrication points**

**B=Fluid level check**

**C=Oil and filter change**

- 1 Brake cam (one on each wheel, not included on disc brakes)
- 19 Rear axle (2 pcs for 6x4 and 8x4)

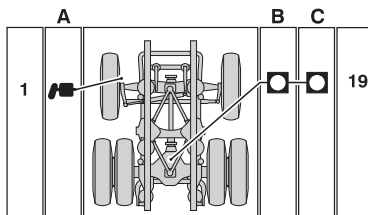

J1008538

4x4, 6x6 vehicles

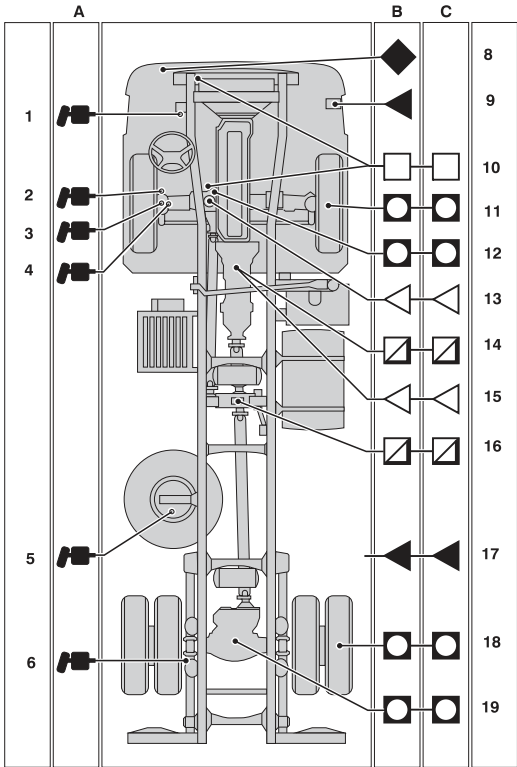

# 612 Maintenance

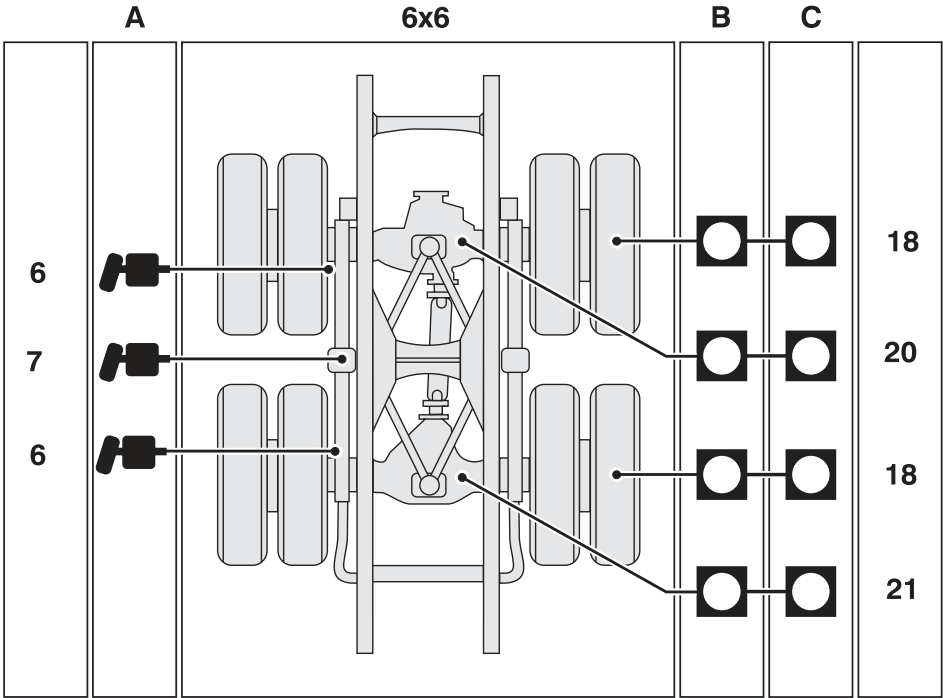

J1008540

**A = Lubrication points**

**B = Fluid level check**

**C = Oil and filter change**

- 1 Intermediate arm (2 pcs)
- 2 Brake cams (2 pcs on each front wheel, not included on disc brakes)
- 3 Steering knuckle bearing upper and lower (2 pcs on each front wheel)
- 4 Universal joint (2 pcs per side)
- 5 Spare wheel holder (1 pce)
- 6 Brake cam (one on each rear wheel, not included on disc brakes)
- 7 Cradle (1 pce per side). Relieve the cradle when lubricating. Lubricate until grease is forced

out.

- 8 Clutch fluid reservoir
- 9 Pump for cab tilt
- 10 Motor
- 11 Wheel gear (2 pcs)
- 12 Differential carrier, driving front axle
- 13 Steering servo reservoir
- 14 Manual gearbox
- 15 Automatic gearbox
- 16 Transfer gearbox
- 17 Hydraulic oil tank (some types)
- 18 Hub reduction (2 pcs)
- 19 Rear axle
- 20 Rear axle, front
- 21 Rear axle, rear

The parking brake must be released during lubrication, so that the grease can be forced into the brake cams. (Applies to vehicles with drum brakes) Chock a wheel with a wooden block or similar, so that the vehicle cannot move while being serviced.

Besides the lubrication points in the lubrication chart, the joints for all controls and levers should be oiled regularly with thin engine oil.



## Central lubrication system

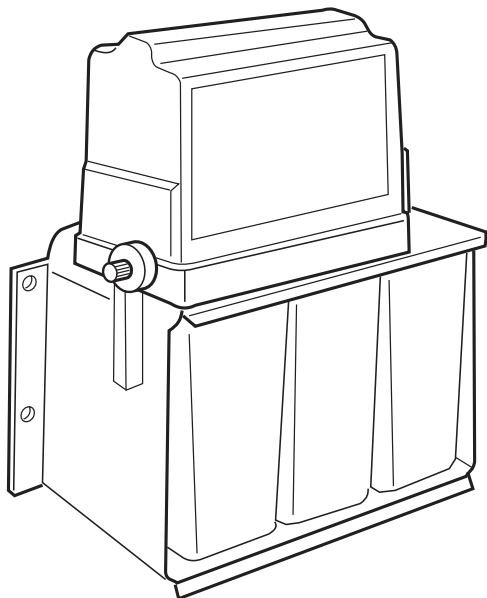

J9007322

## Grease quality

Part	Part number	Note
Volvo Grease 00CS	3093926	
Volvo Grease 00 CSBD	3093927	Bio-degradable

For other approved grease qualities, contact a Volvo dealer.

## Filling intervals

The filling interval for the central lubrication system is every 6th month or when the level has dropped to the min. mark on the reservoir.

The volume is 2.7 kg for tractors and 6 kg for others.

## Type plates, location

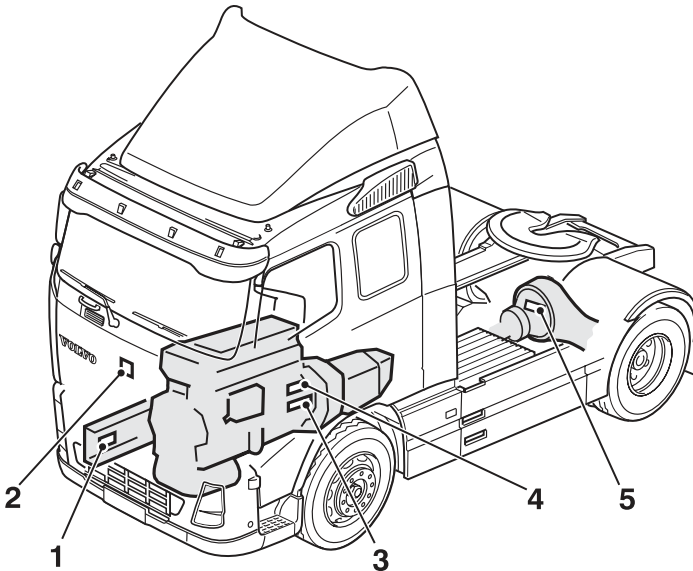

J0009598

- 1 The chassis number is punched on the outside of the right-hand frame member and is also found on the type plate
- 2 The product identification plate is behind the service hatch on FH trucks, and on the inside of the right-hand door on FM trucks. The dimensions plate is next to the product identification plate and the cab number plate is located on the right-hand B pillar
- 3 The engine designation is stamped on the left-hand side of the engine block above the starter motor (plus certain information concerning the ECU or on the valve cover)
- 4 Gearbox plate (right side, clutch housing)
- 5 Rear axle identification plate

# 616 Maintenance

---

The compressed air tanks also have type plates which state:

- Manufacturer
- Part number
- Serial number
- Max operating pressure
- Max operating temperature
- Min operating temperature
- Tank capacity

## General

The truck's fuses and relays are located under the cover in the middle of the instrument panel and in front of the passenger seat.

**The are decals under the cover which show the location of fuses and relays and what they are used for.**

The ordinary exterior lighting of the truck is controlled by a lighting control unit. This contains control functions for each lighting circuit respectively. There are no melt fuses for these functions. If a circuit is broken, for example, due to overloading or a short circuit, the driver will be informed by a message in the instrument. The function is restored once the fault has been remedied.

### Electrical distribution unit, left-hand drive trucks

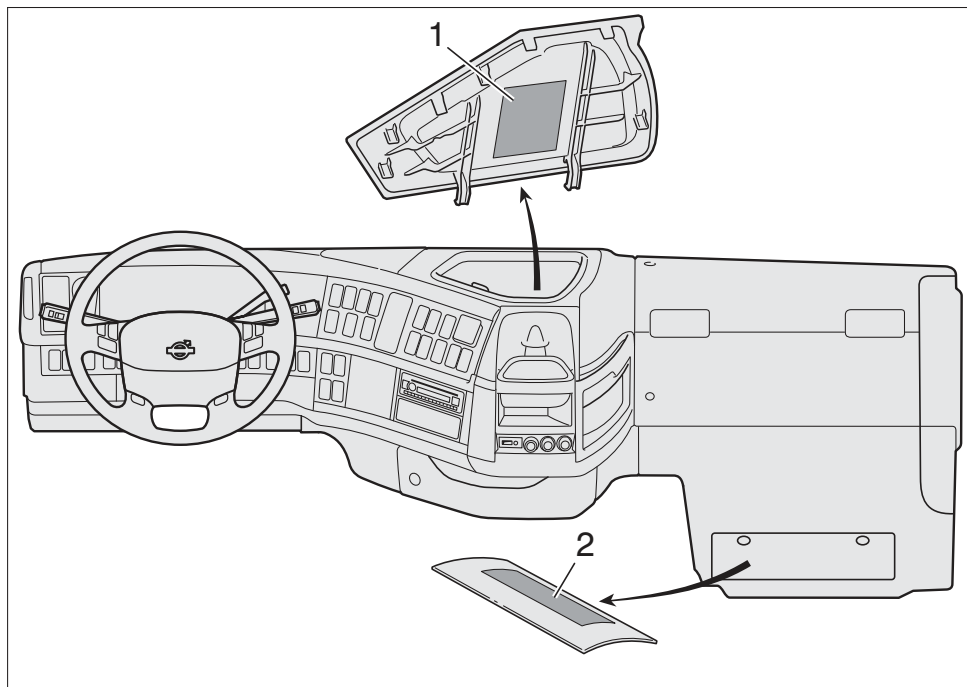

J175064

Under the cover of each electrical distribution unit is a decal with information about the location of the fuses and relays and what they are used for.

- 1 Relay and fuse central with surrounding relays
- 2 Fuses and relays for bodywork

## Electrical distribution unit, right-hand drive trucks

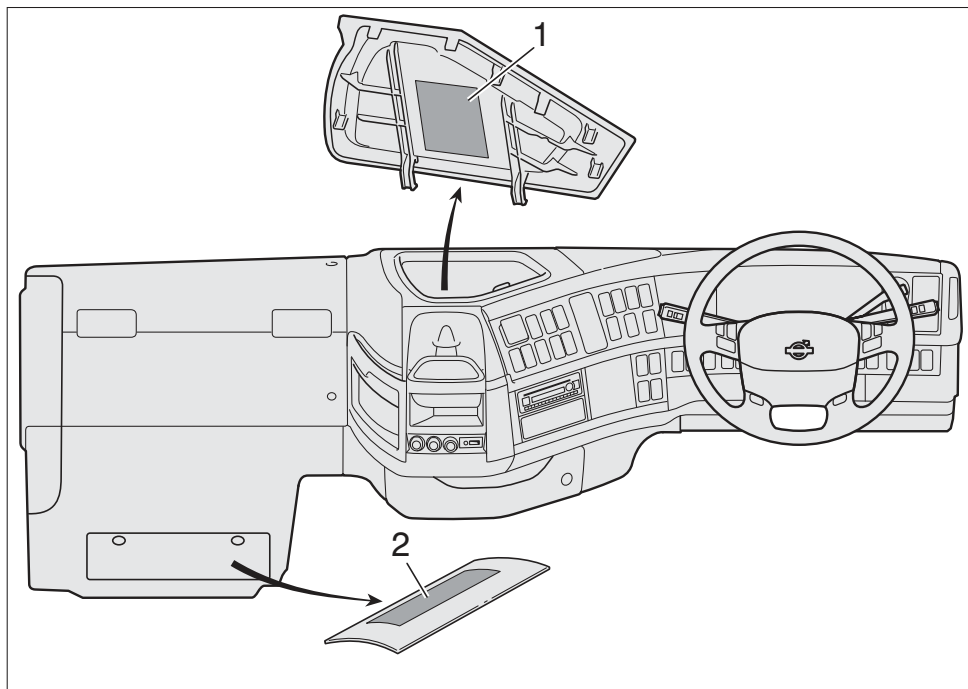

J175044

There is a decal under the cover of each electrical distribution unit with information about the location of the fuses and relays and what they are used for.

- 1 Relay and fuse central with surrounding relays
- 2 Fuses and relays for bodywork

## Main fuses

The main fuses are located in the main fuse box inside the battery box on the chassis. The four fuses are screwed into the fuse box with spring washers and nuts. It is important that the nuts are tightened to the correct torque, see table. If they are not tightened enough, heat can be generated. Too high torque can cause deformation and cracks.



### Warning!

Use the correct tightening torque.  
Do not forget the spring washers.

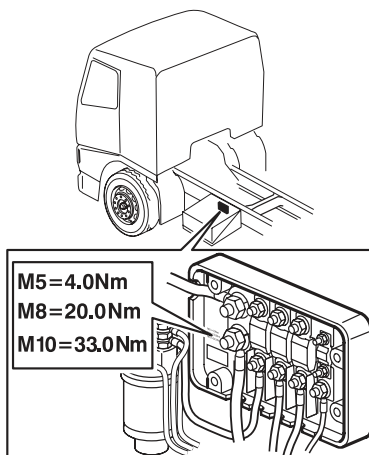

J3014566

Dimensions	Tightening torques
M5	4.0 Nm +/- 5%
M8	20.0 Nm +/- 5%
M10	33.0 Nm +/- 5%

Normally the fuses last as long as the truck without blowing. Should a fuse blow, the truck should be taken in to the workshop for a check of the electrical system.

Size	Use
1 125 A	Preheating

	Size	Use
2	200 A	Hydraulic bogie lift / Superstructure
3	125 A	Cab
4	40 A	Secondary lighting supply



## In relay and fuse box

The fuses in the electrical distributor unit are of the blade fuse type, two different types are used. If a fuse in the same fuse holder has to be changed frequently, the truck should be taken to the workshop for a check on the electrical system.



### Warning!

Always use the stipulated size of fuse. Never use a higher fuse.

### Note!

Switch off the current before changing a fuse. The fuse holder can burn up if the current is on.

## Blade fuses

Fuse no.	Use	Fuse rating
F 1	TPM	10 A
F 2	Lighting, cargo area	10 A
F 3	Loading lamp, fifth-wheel lighting	10 A
F 4	Electrically adjustable seat, cab tilt pump, loading and fifth-wheel lighting	5 A
F 5	Instrumentation (kl. 30)	5 A
F 6	Air drier	5 A
F 7	Vehicle control unit, electronic immobilizer	5 A
F 8	Instrumentation, TPM	5 A
F 9	Range interlock, area interlock (in gearbox)	5 A
F10	NOx sensor, road toll	5 A
F11	Control unit gear shifter	5 A
F12	Control unit transmission/retarder	10 A
F13	Windscreen wiper	15 A
F14	Cigarette lighter, lamp storage compartment, centre section	10 A

Fuse no.	Use	Fuse rating
F15	Water separator, fuel filter heater, water drain valve	10 A
F16	Differential lock, power take-off	5 A
F17	Control unit external lighting	5 A
F18	Horn, solenoid valve for compressed air horn	10 A
F19	Climate unit, FMS gateway	5 A
F20	Central locking, parking heater	10 A
F21	Fan, climate unit	15 A
F22	Courtesy light	10 A
F23	Air suspension	5 A
F24	Air drier, parking heater ADR, electrically heated rear view mirrors	10 A
F25	Power supply, ABS/EBS trailer	20 A
F26	Bodywork fuse box	30 A
F27	Electric window lift left side, electrically heated rear view mirrors	20 A
F28	ABS/EBS	20 A
F29	Coffee maker	30 A
F30	Electric window lift right side	20 A
F31	Main fuse for fuses 95–97	20 A
F32	Climate unit	20 A
F33	Electric cab tilting	30 A
F34	Amplifier	30 A
F35	Electrically adjustable seat	20 A
F36	Circuit for reversing lights, trailer	15 A
F37	Telephone, Dynafleet	5 A
F38	Entry lamps	5 A
F39	Electrically adjustable rear view mirrors	5 A

## 624 Fuses and relays

---

Fuse no.	Use	Fuse rating
F40	Engine control unit	15 A
F41	Solenoid valves on engine, electric fuel pump	10 A
F42	Pre-heating relay engine, electrically controlled cooling fan	5 A
F43	Body builder control unit BBM	5 A
F44	Voltage converter for radio/12 V outlet	15 A
F45	Voltage converter for 12 V outlet	15 A
F46	Rotating beacon	15 A
F47	ACC	5 A
F48	ABS/EBS, switch EBS	5 A
F49	Air suspension/A-ride	3 A
F50	Phone	5 A
F51	Hydraulically steered axle	5 A
F52	Air intake heating, relief relay radio position	10 A
F53	Illuminated sign on roof	10 A
F54	Dynafleet, FMS gateway	10 A
F55	Airbag, seat belt tensioner	5 A
F56	Free	5 A
F57	Control unit gear shifter/Retarder	3 A
F58	D+ short circuit relay, only ADR	5 A
F59	Reversing camera, Dynafleet	5 A
F60	Hydraulically steered axle	5 A
F61	Theft alarm, Volvo link (SAM), Folding rear view mirror arm, Japan	5 A
F62	Free	15 A
F63	Alcolock system	10 A
F64	Toll system	10 A
F65	Central lubrication system	10 A

Fuse no.	Use	Fuse rating
F66	Sun roof	10 A
F67	Bunk lamps, reading lamps	10 A
F68	Refrigerator	10 A
F69	12 Volt outlet	10 A
F70	ABS/EBS, trailer (kl. 15)	5 A
F71	Extra equipment	10 A
F72	Level adjustment system, headlamps	5 A
F73	Hydraulically steered axle	5 A
F74	Headlamp washer (high pressure)	15 A
F75	Electrically heated seats	15 A
F76	ADR D+ short circuit relay, Fan instrument panel	5 A
F77	24 V Power outlet, instrument panel	10 A
F78	24 V Power outlet, beside bunk	10 A
F79	12 V for TV	10 A
F95	Central locking	10 A
F96	Burglar alarm	5 A
F97	Parking heater	15 A

## LCM fuses

1	Direction Indicator lights trailer, Brake Lights and Headlight dipped beam, right side, Reversing Lights, Parking Lights rear	25 A
2	Headlight main beam left side, Fog Lights, Warning light, Warning signal	25 A
3	Brake Lights trailer and Direction Indicator lights rear, left side, Headlight main beam right side	25 A
4	Parking Lights trailer and Direction Indicator lights rear, right side, Brake Light left side	25 A
5	Reverse Lights trailer, Parking Lights front right side, Headlight dipped beam and Direction Indicator lights trailer, left side	25 A
6	Parking Lights trailer and Parking Lights front, left side, Direction Indicator lights front	25 A

# 626 Fuses and relays

---

## Fuses in the battery box

1	Tachograph	5 A
2	Main fuses F95–F97	20 A
3	AdBlue system	20 A

## To superstructure

### 56 X. Fuses for superstructure

	Use	Fuse size
1	Kl.30, B+	15A
2	Kl.30, B+	15A
3	Kl.15, driving position	15A
4	Kl.15, driving position	15A
5	Kl.61, alternator	10A
6	Free	10A

### 56 P. Fuses for superstructure (options)

	Use	Fuse size
1	Kl.30, B+	15A
2	Kl.30, B+	15A
3	Kl.30, B+	15A
4	Kl.30, B+	15A
5	Free	10A
6	Free	10A

## Relays for bodywork, in front of passenger seat

Loc.	Function:
37	Parking lights
38	Pressure selection, dumper trailer
39	Free, for body builder
40	Free, for body builder
41	Free, for body builder
42	Spotlights
43	External engine start
44	Reversing light
45	Brake application (reverse lock)
46	Free, for body builder
47	Free, for body builder

### **Note!**

The continuous load on a fuse may not exceed 80 % of the rated current. Fuses must always be replaced with genuine fuses.

## Air suspension in locked mode

If there is a fault, the air suspension may go into the locked mode. This disconnects the automatic ride height.

### Note!

The vehicle should be taken to the workshop as soon as possible, but can be used in the mean time.

## To adjust the height

### 1 Control both sides at the same time

In the driving position, both sides are controlled at the same time. The air in the bogie axle's bellows is adjusted at the same time as the air in the drive axle is adjusted.

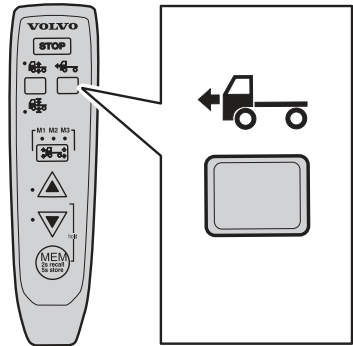

J7009822

### 2 Use the axle switch to select the axle to be adjusted:

- M1 for the front axle.  
The air in the bogie axle's bellows is adjusted at the same time as the air in the drive axle is adjusted.
- M2 for both front and rear axles.  
The air in the bogie axle's bellows is adjusted at the same time as the air in the drive axle is adjusted.
- M3 for rear axle.  
The air in the bogie axle's bellows is adjusted at the same time as the air in the drive axle is adjusted.

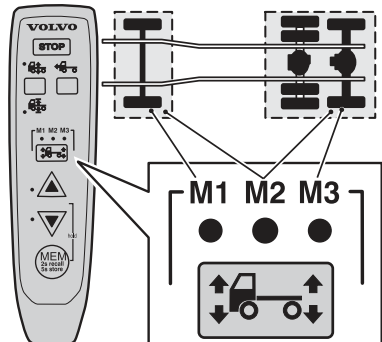

J7009818

3 Adjust the height with the adjustment switch.

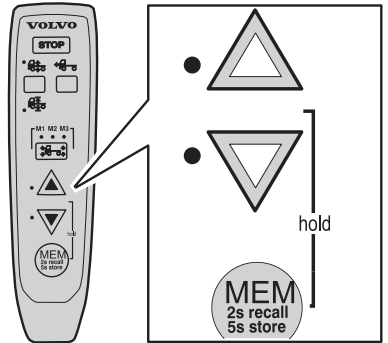

J7009819

## Adjust the amount of air in the bogie axle's lifting bellows

Drain the lifting bellows by pressing on the lower part of the bogie switch.

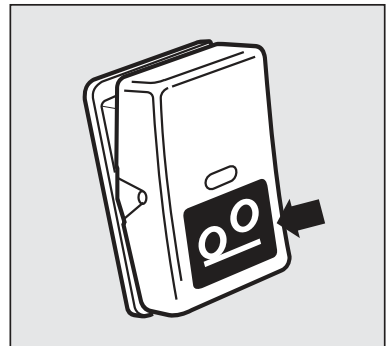

J7008415



## Airbag

The air bag is to be inspected and if necessary replaced, by an authorised Volvo workshop at **the year and month** noted on the label mounted on the door frame. This must be done to ensure full functionality after the stated date. Do not do any work on this system yourself.

### When is the airbag inflated?

The airbag inflates only in the case of a **head-on collision** with a fixed or heavy object.

If the airbag has inflated:

- Tow the truck to a Volvo workshop. Do **not** drive with a deployed airbag.
- Have an authorised Volvo workshop change the components in the system.
- Only Volvo original spares should be used when components are changed (airbag, belts etc.).

### When is the airbag not inflated?

- In the case of a collision with a soft object, such as a snow drift or thicket.
- In the case of a collision at low speed.
- In the case of a collision from the side, being driven into from the rear or if the truck should overturn.

Superficial damage to the bodywork is not an indication of whether the system functioned or not.

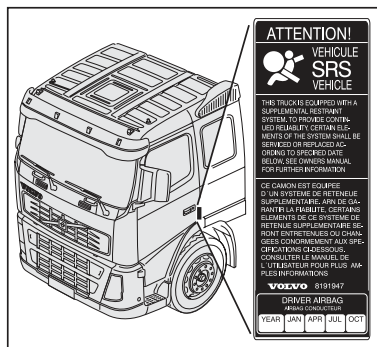

J8008485



### Warning!

If the truck is equipped with an air bag, this is **not** a replacement for the ordinary seat belt! The airbag is **not** inflated during a rear-end collision, side collision or if the truck rolls over.

**Always use the seat belt!**



### Caution!

Never drive with a deployed airbag. By hanging out, it can make steering the vehicle difficult. Other safety systems may also be damaged. The smoke and dust caused by triggering the airbag can cause skin and eye irritation with long-term exposure.

## **Warning!**

You should **never** try to repair any part of the system yourself. All interference with the system can cause malfunction and serious personal injury and may only be carried out by an authorised Volvo workshop.

## Warning signs and first-aid

The truck has two warning triangles. The warning triangles are stored in the space behind the left hand seat. Certain trucks also have first aid kits, warning flares and high visibility vests.

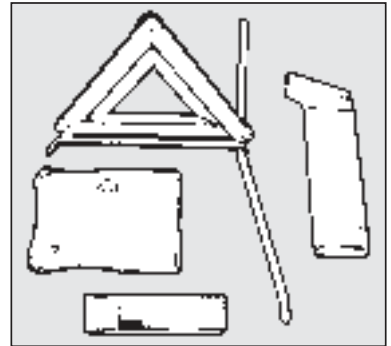

J0008197

## Fire extinguisher

If there is a fire extinguisher, it is located near the driver's seat.

The fire extinguisher must, once a month, be taken out and turned upside down to prevent the powder from settling.

### Starting with starting cables

Always use another vehicle or other batteries to help start the engine.

- 1 Turn the ignition key to the 0 position.
- 2 Make sure that the help start battery has 24 V total voltage or 24 V system voltage.
- 3 Switch off the engine of the assisting vehicle and make sure that the vehicles do not touch one another.
- 4 Connect one of the clamps on the red cable to the positive terminal on the help battery. The positive pole is marked in red, P or +.
- 5 Connect the other clamp on the red cable to the positive terminal on the battery of the vehicle that needs help. The positive pole is marked in red, P or +.
- 6 Connect one clamp on the black cable to the negative terminal of the help battery marked in blue, N or -.
- 7 Connect the other clamp on the black cable to a place - an earth - some distance from the battery of the vehicle which needs help.
- 8 Start the engine on the "assisting vehicle". Let the engine run for some minutes at a higher speed than normal (about 1000 rpm).
- 9 Start the engine on the other vehicle.
- 10 Remove the clamp on the black cable from the earth point.
- 11 Remove the clamp on the black cable from the negative terminal on the help battery.
- 12 Remove the red cable.



#### Caution!

So-called start help units must not be connected, because these can give very high voltages, which can in turn damage control units.

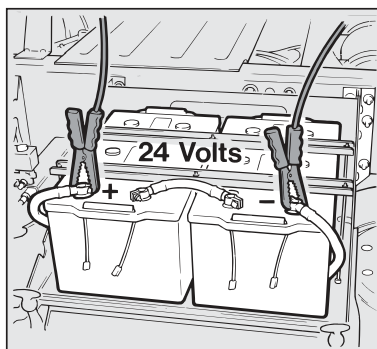

J0008254

#### Note!

After the truck has been started by using starting cables, the batteries should be charged with a battery charger. It takes about 20 hours to fully charge a battery. An alternator can never charge the battery to 100%; in favourable circumstances a maximum level of 90% can be achieved.

## Note!

Batteries contain acid which is corrosive and poisonous. It is therefore important that batteries are handled in an environmentally safe manner. Let your Volvo dealer help you.

### **Warning!**

Batteries contain oxyhydrogen gas which is very explosive. A spark, which can ignite if you connect the starting cables incorrectly, or if they are moved around during the starting procedure, is sufficient for the battery to explode and cause serious damage and injury. Batteries contain sulphuric acid which can give serious burns. If the acid gets in your eyes, skin or clothes, rinse with large amounts of water. If the acid gets in your eyes, get medical attention at once. Do not lean over the batteries.

## Battery box rear

Always use another vehicle or other batteries to help start the engine.

The starting cables shall be able to handle 1000 A for at least 30 seconds.

- 1 Turn the ignition key to the 0 position.
- 2 Make sure that the help start battery has 24 V total voltage or 24 V system voltage.

### **Caution!**

So-called start help units must not be connected, because these can give very high voltages, which can in turn damage control units.

## 634 If something happens

---

- 3 Switch off the engine of the assisting vehicle and make sure that the vehicles do not touch one another.
- 4 Connect one of the clamps on the red cable to the positive terminal on the help battery. The positive pole is marked in red, P or +.
- 5 Connect the other clamp on the red cable to the positive terminal on the battery of the vehicle that needs help. The positive pole is marked in red, P or +.
- 6 Connect one clamp on the black cable to the negative terminal of the help battery marked in blue, N or -.
- 7 Connect the other clamp on the black cable to a place - an earth - some distance from the battery of the vehicle which needs help.
- 8 Start the engine on the "assisting vehicle". Let the engine run for some minutes at a higher speed than normal (about 1000 rpm).
- 9 Start the engine on the other vehicle.
- 10 Remove the clamp on the black cable from the earth point.
- 11 Remove the clamp on the black cable from the negative terminal on the help battery.
- 12 Remove the red cable.

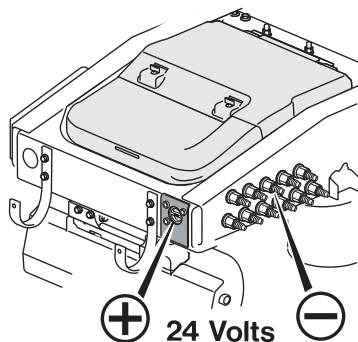

### Note!

Batteries contain acid which is corrosive and poisonous. It is therefore important that batteries are handled in an environmentally safe manner. Let your Volvo dealer help you.

### Note!

After the truck has been started by using starter cables, the battery should be charged with a battery charger. It takes about 20 hours to fully charge a battery. An alternator can never charge the battery to 100 %; in favourable circumstances a maximum level of 90% can be achieved. See the "Electrical system" section in the "Driver's Manual" for more information.

## Warning!

Batteries contain oxyhydrogen gas which is very explosive. A spark, which can ignite if you connect the starting cables incorrectly, or if they are moved around during the starting procedure, is sufficient for the battery to explode and cause serious damage and injury. Batteries contain sulphuric acid which can give serious burns. If the acid gets in your eyes, skin or clothes, rinse with large amounts of water. If the acid gets in your eyes, get medical attention at once. Do not lean over the batteries.

## Towing

### Procedure before towing

- Remove the propshaft
- Insert the towing brace and towing pin
- Applying chocks to the wheels before the hand-operated parking brake is disengaged
- Turn off TCS. Otherwise the system may activate and the truck become disconnected from the towing vehicle.
- Start the engine and let it run during the entire towing operation. Lift up the bogie axle so that the wheels do not turn when the truck is being reversed.

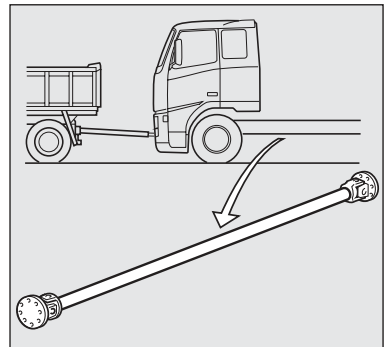

J4018161

Use a tow rod.

The power steering does not operate during towing and the vehicle will be heavy to steer.

### Caution!

The gearbox can be damaged if the propshaft is not removed. When shunting (a few hundred meters) a vehicle with a manual gearbox, the propshaft can remain in place if high gear is engaged.

### Warning!

Always use a towing brace and towing pin when towing. Never tow from the forward underrun guard. The underrun guard is not designed to withstand this sort of force.

## Insertion of towing brace and towing pin

Use towing brace (1) and towing pin (2) for towing.

- 1 Get out the towing brace (1) and the towing pin (2)  
They are in the storage space or behind the seats
- 2 Separate the towing brace (1) and the towing pin (2)
- 3 Open the hatch by the footstep
- 4 Push in the towing brace (1)
- 5 Turn the towing brace (1) a quarter revolution
- 6 Pull out the brace (1) to the correct position
- 7 Engage the towing pin
- 8 Push the towing pin (2) through the towing brace (1) flange
- 9 Push the locking pin through the towing pin
- 10 Lock the pin with the ring (3)

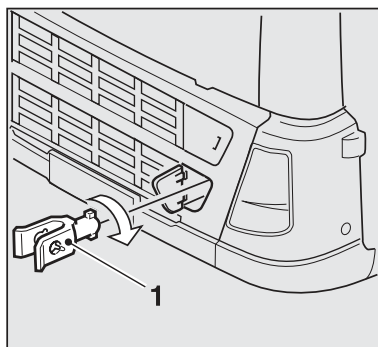

J9007790

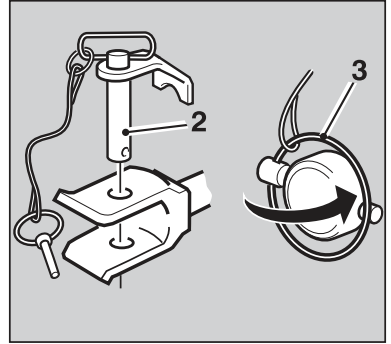

J0010970

 **Warning!**

The towing brace may only be used when towing on good roads. It is not intended for recovery.

**Note!**

Lock the towing pin by turning the handle 60° clockwise. Each towing brace may be loaded from straight ahead with half the gross weight of the truck.

## Towing backwards

Tow from the rear axle, rear spring anchorage or trailer hitch hook.

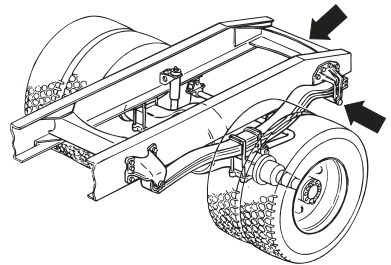

J0006679



### Towing sideways

Choose a point close to the axle attachment, e.g. the spring bracket or reaction rod bracket. Otherwise the chassis could be subjected to such heavy loading that it could be deformed.



#### Caution!

Do not use the anti-roll bar or torque stay for towing.

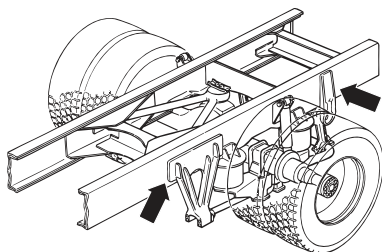

### Disengage the hand-operated parking brake

If the engine will not start there are two ways of disengaging the hand-operated parking brake. Either replenish the air in the compressed air system, for example from another vehicle, or disengage the hand-operated parking brake mechanically.



#### Warning!

Always start by applying chocks to the wheels, so that the truck cannot roll away. This is very important for all work underneath the truck.

## Putting air in the compressed air system

Always use the test nipple on the air drier. Tilt the cab to access the test nipple.

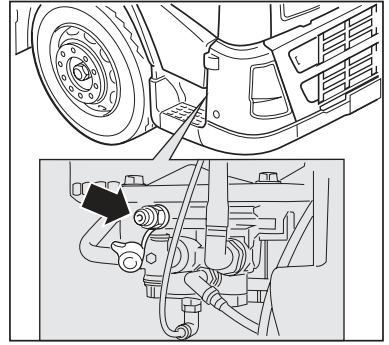

J5012251

## Mechanically disengaging the hand-operated parking brake

Remove any plastic cap from the back of the cylinder. Unscrew the nut which then becomes visible, using the intended tool from the tool box, until the brake is released. Either the entire screw will come out or just the nut will be visible.

### **Note!**

Some vehicles have parking brake cylinders for both front and rear axles.

### **Note!**

Always put air in the tanks for the hand-operated parking brakes, when available, and loosen the hand-operated parking brake to make the nut easier to screw. This protects the brake cylinder from unnecessary wear.

## 640 If something happens



### Caution!

Never loosen or tighten the nut mechanically when loosening or replacing the hand-operated parking brake. The cylinder can be damaged.

### The entire screw comes out

Unscrew the nut until the brake releases. The nut and screw come out of the brake cylinder.

Screw the screw back in and replace the plastic cap after towing.

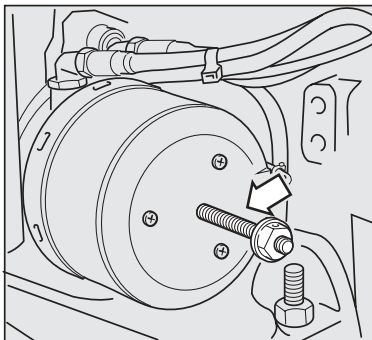

J0009318

### Only the nut shows

When you start to unscrew the nut, a red plastic button comes out of the centre of the nut. After about four turns it is completely out but another 45 turns or so are required for the brake to be completely released.

After towing: Screw the screw back in until the red plastic button goes all the way in.

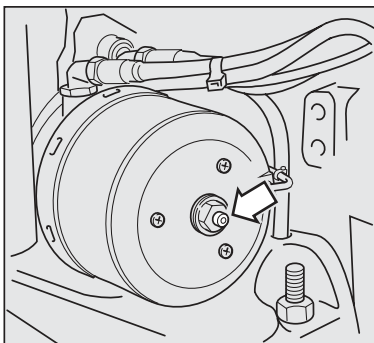

J0009317

## Back-up function

Even if a fault should occur within the electrical braking pressure control, it is still possible to brake the vehicle. A built-in back-up function guarantees brake operation via partial or complete pneumatically controlled operation. The brake pedal travel will in this case, be somewhat greater than normal and higher brake pedal pressure may be required to achieve the same stopping power. In back-up mode, the ABS system is disengaged partly or wholly, depending on where the fault occurred.

When EBS is disconnected the "stop message" lamp on the display lights continuously (red). The information on the display shows the text "Stop Brake ECU failure".

## In case of gearbox malfunction

An "L" on the display and a yellow information lamp indicate that a data link to the engine has been broken. The Powertronics system then activates Limp home. This function makes it possible to drive the vehicle for short distances in case of a malfunction, to the closest garage for example.

When Limp home is activated, only manual gear changing is possible. The driver can change gears when the gear selector is in position M or R by using the up/down button.

Power take-offs are shut off automatically when Limp home is activated. It is possible to re-engage it as long as the engine speed is kept below 1000 rpm. All special functions on the vehicle will be terminated and cannot be activated.

When the fault on the truck has been rectified Limp home is turned off automatically.

### **Note!**

The accelerator pedal must be released before changing gear so that the engine torque is reduced. This also applies when engaging the lock-up function.

### **Note!**

The auxiliary brakes must be turned off when changing down.

## 642 If something happens

---

### **If the vehicle gets stuck**

If the truck gets stuck it may be possible to "rock it free" by moving the gear selector between R and A positions with light accelerator pressure. This may only be done at low engine speeds (below 1100 rpm) and a maximum road speed of 5 km/h.

**A**

About ACC ..... 197  
 ABS fails ..... 152  
 ACC, change speed ..... 199  
 ACC, driving on bends ..... 201  
 Activate ACC ..... 198  
 Adaptive Cruise Control ..... 197  
 AdBlue, filling ..... 297  
 AdBlue, gauge ..... 49  
 AdBlue, tank cleaning ..... 299  
 AdBlue, with spillage ..... 298  
 AdBlue ..... 293  
 Adjusting the seat ..... 309, 310  
 Adjusting the steering wheel ..... 313  
 ADR ..... 193  
 Air cleaner, change filter ..... 539  
 Air conditioning, maintenance ..... 605  
 Air conditioning, replace air filter ..... 605  
 Air conditioning ..... 318, 326  
 Air distribution ..... 320, 324, 326  
 Air pressure gauge, front braking circuit ..... 18  
 Air pressure gauge, rear braking circuit . 18  
 Air suspension, Symbols ..... 40, 87, 308  
 Air suspension ..... 1  
 Airbag ..... 630  
 Alarm clock ..... 52  
 Alarm ..... 359  
 Alcolock, additional features ..... 381  
 Alcolock, energy conservation ..... 380  
 Alcolock, messages and errors ..... 383  
 Alcolock, start up ..... 373  
 All wheel drive ..... 135  
 Aluminium rims ..... 521  
 Ammeter sensor calibration ..... 66  
 Ammeter ..... 47  
 Amplifier ..... 2, 444  
 Anti Theft Code (Guard), radio .... 404, 427  
 Assistance button ..... 363  
 ATS ..... 58  
 Audio settings, radio ..... 401, 419  
 Automatic cut-off ..... 331

Automatic engagement of the differential lock ..... 146  
 Automatic gear change ..... 241  
 Automatic gear changing ..... 209  
 Automatic shut-off ..... 332  
 Autoneutral ..... 211  
 Aux mode, radio ..... 418  
 Auxiliary brakes, Powertronic ..... 212  
 Auxiliary brakes ..... 148  
 Available gears ..... 240  
 Average speed ..... 50  
 Axle load, increase ..... 167

**B**

Backlight ..... 53, 63, 94, 132  
 Back-up function, EBS ..... 641  
 Battery for the smoke detector ..... 354  
 Black Panel ..... 53, 93  
 Blocking valve ..... 27  
 Bluetooth hands free phone mode ..... 421  
 Bogie lamp ..... 159, 308  
 Bogie lift, maintenance ..... 603  
 Bogie lift, oil recommendations ..... 603  
 Bogie lift ..... 158  
 Bogie ..... 159  
 Booster ..... 2, 444  
 Brake Blending ..... 152  
 Brake interlock ..... 211  
 Brake lining wear ..... 77  
 Brake lining, status ..... 72  
 Brake lining ..... 154, 577  
 Brake protection ..... 202  
 Brake temperature ..... 78  
 Braking program ..... 244  
 Braking system, maintenance ..... 575  
 Bunk net, lower bunk ..... 353  
 Bunk net, upper bunk ..... 352  
 Burglar alarm ..... 359  
 Buttons, gear shifter, Up/Down changing ..... 206  
 Buttons ..... 238

**C**

Cab heater (ADR) ..... 328, 333

- Cab tilt pump, maintenance ..... 604  
Cab, equipment ..... 303  
Calibration ID ..... 99  
Calling ..... 432  
Camera ..... 131  
CD mode ..... 399, 411  
Central locking ..... 316  
Central lubrication ..... 604  
Change a setting in the display ..... 45  
Change air filter ..... 539  
Change idle speed ..... 11  
Change language, display ..... 104  
Change time gap ..... 200  
Changing front wheel on a fully  
air suspended truck ..... 597  
Changing wheels ..... 593  
Charge pressure gauge ..... 17  
Chassis lubrication ..... 607  
CHECK lamp ..... 103  
Check oil level, Powertronic ..... 215  
Climate control system ..... 323  
Clock, radio ..... 402, 425  
Clutch ..... 7  
Clutch-independent PTO ..... 177  
Communication equipment ..... 359  
Compact retarder, oil  
recommendations ..... 571  
Compact retarder ..... 148  
Constant engine speed control ..... 170  
Construction site driving ..... 251  
Container handling ..... 284  
Container, collect ..... 284  
Container, leave ..... 286  
Contrast, setting ..... 63  
Control box ..... 303  
Control of engine torque ..... 153  
Controls, Dynafleet ..... 450  
Cooling system, drain ..... 542  
Couple the trailer ..... 500  
Crawler gear ..... 155  
Cruise control with braking ..... 151  
Cruise control, disengage ..... 169  
Cruise control, engage ..... 169  
Cruise control ..... 169
- D**
- Daily inspection ..... 504  
DAS ..... 64  
Data log ..... 72  
Date, setting ..... 62, 96  
Date ..... 51  
Day Running Light ..... 22  
Day running lights automatic, setting ..... 68  
Day running lights, setting ..... 97  
Derating (power reduction) ..... 292  
Diagnostics ..... 69, 97  
Diesel particulate filter ..... 58, 299  
Diff Lock Control ..... 146  
Differential lock, automatic  
engagement ..... 146  
Differential lock, engage ..... 140  
Differential lock ..... 136  
Differential locks, engage ..... 143  
Disengage ACC ..... 199  
Disengage cruise control ..... 199  
Disengage the cruise control ..... 169  
Disengaging ..... 251  
Display control stalk ..... 82, 102  
Display lighting, setting ..... 63  
Display symbols ..... 36  
Display, general ..... 33  
Display, I-Shift ..... 239  
Display, overview ..... 81  
Display, Powertronic ..... 207  
Display, setting ..... 61  
Display, settings ..... 94  
Display ..... 80, 102  
Distribute the load ..... 166  
Doors, Door lock ..... 314  
Draining ..... 68, 97  
Drive belts, maintenance ..... 546  
Drive/rest time, Dynafleet ..... 459  
Drive/rest time ..... 459  
Driver Alert Support ..... 174  
Driver coaching, Dynafleet ..... 464  
Driving a vehicle with ACC ..... 201  
Driving and resting time ..... 53

Driving at low speed ..... 203  
 Driving front axle, maintenance ..... 567  
 Driving front axle, oil  
 recommendations ..... 566  
 Driving on rollers ..... 254  
 Driving Powertronic, Driving  
 programs ..... 209  
 Driving programs ..... 239, 244  
 Driving support system ..... 170  
 Driving tips ..... 248  
 Driving, I-shift ..... 222, 232  
 Dual driver stations ..... 212  
 Dynafleet, main menu ..... 457  
 Dynafleet ..... 2, 447

**E**

EBS, general ..... 1  
 Economy program ..... 244  
 Economy/Power (E/P) ..... 206, 238  
 Electric trailer brake ..... 29  
 Electric welding ..... 547  
 Electric window lifters ..... 316  
 Electrical power outlet ..... 351  
 Electrical system, maintenance ..... 546  
 Electrically controlled rear view  
 mirrors ..... 315  
 Electrically heated rear view mirrors ... 315  
 Electronic Stability Program ..... 153  
 Emergency alarm & Assistance,  
 Dynafleet ..... 465  
 Emergency alarm & Assistance ..... 465  
 Emergency alarm button ..... 452  
 Engage differential lock ..... 137  
 Engage the cruise control ..... 169  
 Engaging a gear ..... 246  
 Engine brake ..... 249, 253  
 Engine heater (ADR) ..... 333  
 Engine oil, filling ..... 527  
 Engine oil, replace ..... 528  
 Engine wash ..... 516  
 Engine, oil recommendations ..... 525  
 Engine-mounted power take-off ..... 177  
 ESP ..... 153  
 Estimated time of arrival ..... 51

Euro 4 ..... 291  
 Exhaust cleaning, SCR ..... 291  
 Exhaust cleaning ..... 293  
 Exhaust ..... 296

**F**

Fault code, non-deletable ..... 292  
 Fault codes, EBS ..... 78  
 Fault diagnostics ..... 69  
 Fault Diagnostics ..... 97  
 Favourite Display ..... 54  
 Filling with AdBlue ..... 297  
 Fire extinguisher ..... 631  
 First Aid ..... 631  
 Fleet ID, setting ..... 66  
 Fleet limits, setting ..... 64  
 Fog light ..... 22  
 Freewheel, I-Roll ..... 242  
 Freewheel ..... 248  
 Fridge ..... 368  
 Front mirror ..... 490  
 Front wheel drive, engage ..... 135  
 Fuel consumption ..... 48  
 Fuel Data ..... 90  
 Fuel economy driving ..... 248  
 Fuel filter, replace ..... 536  
 Fuel gauge ..... 18  
 Fuel heater ..... 12  
 Fuel system, maintenance ..... 530  
 Fuses and relays, general ..... 617  
 Fuses, booster ..... 444  
 Fuses ..... 620, 622

**G**

Gauges ..... 17, 89  
 Gear position ..... 48  
 Gear selector ..... 217  
 Gear shift lever lock ..... 236  
 Gear shift lever position ..... 237  
 Gear shifter, Gear shift lever ..... 205  
 Gear shifter ..... 236  
 Gearbox, maintenance ..... 552, 559, 560  
 Gearbox, oil recommendations ..... 554  
 Gearbox ..... 154, 217, 232



Gearbox-mounted power take-off .....	178
Grease .....	523
Greatest possible down-change .....	249

## H

Headlights, replace light bulb .....	510
Headlights .....	22
Heavily loaded vehicle .....	155
Heavy starts .....	252
High range lock-up .....	179, 181
High speed range .....	155
High split .....	157
Hill start assist .....	130
Hill start .....	250
Hydraulic bogie lift, oil recommendations .....	603
Hydraulic oil .....	603
Hydraulic system, purge .....	359

## I

Idle speed .....	11
Idling speed .....	213
Idling .....	296
If the heater stops .....	340
Information messages .....	35
Instrument panel cluster self test .....	70
Instrument, symbols .....	19
Instrumentation .....	13
Instruments and controls, I-shift .....	217
Instruments and controls, I-Shift .....	236
iPod mode, radio .....	416
I-Roll .....	248
I-shift, driving .....	222, 232
I-shift, general .....	217
I-Shift, general .....	232
I-shift, Instruments and controls .....	217
I-Shift, Instruments and controls .....	236
I-shift .....	217

## J

Jerk starting .....	252
---------------------	-----

## K

Keys .....	7
Kickdown .....	210, 245

## L

Ladder .....	491
Lane Change Support .....	172
Lane Keeping Support .....	170
Language, numerical .....	102
Language, setting .....	61
Language, settings .....	94
LCS .....	64, 172
Leg data .....	49
Lift the bogie .....	158
Lifting the axle .....	165
Light bulb, replace .....	510
Lighting .....	22, 344, 345
Limp home .....	212, 239, 248, 641
Load distribution .....	166
Load indicator .....	72, 287
Locking gear .....	243
Locking the doors .....	317
Logs, Dynafleet, Dynafleet, logs .....	462
Low speed range .....	155
Low speed, disengagement .....	203
Low split .....	157
Lower bogie axle .....	158
Lower bunk .....	352
Lower the axle .....	165
Lubrication .....	604
Luggage compartment hatch .....	343
Luggage compartment, lighting .....	343
LVD system .....	1
LVD-system .....	1

## M

Mail menu, Dynafleet .....	458
Main fuses .....	620
Main menu, Dynafleet .....	457
Main switch .....	318
Maintenance .....	504
Manual braking .....	202
Manual changing .....	246
Manual gear changing .....	210
Manual gearbox .....	154
Marshalling .....	213
Memory for seat position .....	309

Menus when driving .....	42, 104	Passenger seat .....	311
Menus when stationary .....	43	Password, change .....	63
Menus .....	42	Password .....	74
Message .....	82	P-Heater Timer, setting .....	60
Messages, general .....	34	P-heater timer, Setting .....	96
Mobil telephone .....	359	Poly-V .....	546
Monitoring of the wheel brakes .....	78	Poor starting conditions .....	155
<b>N</b>		Power program .....	244
Night mode .....	63	Power take-off, flywheel mounted .....	570
Night/Day .....	56, 94	Power take-off, maintenance .....	570
Non-deletable fault code .....	292	Power take-off .....	176
Number tag .....	7	Power, radio .....	395, 406
Numerical language .....	102	Powertronic, High range lock-up .	179, 181
Numerical translation table .....	116	Powertronic, Instruments and controls .	207
<b>O</b>		Powertronic .....	205
OBD .....	294	Pressure, primary tank .....	48
Office packet .....	352	Prevents down-changing .....	249
Off-road driving .....	251	Prevents up-changing .....	249
Oil filter, Powertronic .....	215	Primary tank, pressure .....	48
Oil level .....	72	Priming .....	68, 97
Oil pressure gauge .....	17	Procedure before towing .....	635
Oil pressure, Powertronic .....	215	Program packages .....	232
Oil recommendations, engine .....	525	Purge the hydraulic system .....	359
Oil temperature, Powertronic .....	214	<b>Q</b>	
Oils .....	523	Queue driving .....	203, 250
Orders, Dynafleet .....	461	<b>R</b>	
<b>P</b>		Radio mode .....	395, 406
Panic Alarm .....	361	Rain sensor .....	25
Panic braking function .....	154	Range gear .....	155
Parking brake, release .....	638	Rear axle, maintenance .....	580, 584
Parking brake .....	26	Rear axle, oil recommendations .....	580
Parking heater (ADR) .....	328	Rear view mirror, electric heating .....	315
Parking heater(ADR) .....	333	Rear view mirror .....	315
Parking heater, maintenance .....	606	Rear view mirrors .....	315
Parking heater, start with time		Recirculation .....	319, 323, 326
delay (ADR) .....	329	Reference pressure .....	57
Parking heater, temperature .....	328	Refrigerator box, tilt cab .....	370
Parking heater, time delayed		Refrigerator .....	364
starting (ADR) .....	336	Refuelling .....	508
Parking heater, time delayed starting ...	329	Regeneration .....	299
Parking .....	7	Relay and fuse box .....	622
Part number .....	71, 99	Release, parking brake .....	638

Remaining fuel .....	49
Remote control, replace battery .....	510
Remove mist and ice from windows .....	322, 325, 327
Replace engine oil .....	528
Replace fuel filter .....	536
Replace wiper blade .....	509
Reset data .....	58
Reset trip data .....	74
Reset, p-heater timer .....	61
Rest heater .....	341
Retarder temperature, Powertronic .....	214
Reverse camera .....	131
Reverse gear .....	154
Reverse gears .....	247
Reversing Warner .....	133
Reversing Warning .....	133
Reversing with loads .....	212
Rims .....	521
Rocking free .....	213, 251
Roof air deflector .....	470, 476, 483
Roof hatch, Electrically controlled roof hatch .....	344
Running in .....	4

## S

SCR, exhaust cleaning .....	291
Seats .....	309, 310
Select starting gear .....	210
Selected gear .....	240
Service reminder, forewarning .....	75, 99
Service reminder, warning .....	76, 100
Service reminder .....	75, 99
Servo steering, maintenance .....	578
Servo steering, oil recommendations ...	578
Set speed .....	198
Setting the temperature .....	321, 325, 327
Settings menu, Dynafleet .....	467
Shutting off the system, Dynafleet .....	456
Side underrun guard .....	492
Smoke detector .....	353
Snow chains .....	602
Spare wheel retainer behind the cab .....	496
Spare wheel .....	494

Split control .....	157
Split .....	157
Stalk for auxiliary brake .....	150
Start and stop, Compressed air, gearbox ...	5
Start and stop, I-Shift .....	5
Start and stop .....	5
Start engine heater only .....	339
Start the engine .....	8
Start the rest heater .....	341
Starting on hills .....	130
Starting the heater .....	328
Starting when stuck .....	251
Starting with starting cables .....	632, 633
Status symbols .....	40
Steel rims .....	521
Steered rear axle .....	168
Steering wheel adjustment .....	313
Steering, filter replace .....	579
Steering .....	578
Step between the menus .....	45
Stop lamp .....	103
Stop message .....	36, 103
Stop symbol .....	103
Subwoofer .....	2, 444
Superstructure, fuses .....	626
Superstructure, oil recommendations ...	603
Swap body handling .....	276
Swap body platform .....	276
Swap body, collect .....	276
Swap body, leave .....	281
Switch off the main switch .....	318
Switching off the TCS .....	134
Symbol for ACC .....	198
Symbols for air suspension .....	40, 87, 308
Symbols in the instrument .....	19
Symbols, Air suspension .....	40, 87, 308
Symbols .....	36, 84

## T

Tachometer .....	17
TCS .....	133
Telephone .....	430
Temperature gauge for coolant .....	18
Temperature, engine oil .....	47

Temperature, gearbox ..... 47  
 Temperature, outside ..... 47  
 Terrain-TCS ..... 133  
 Text strings ..... 103  
 Tilt the cab ..... 355  
 Tilting the cab ..... 366  
 Tilting the gear shift lever ..... 237  
 Time gap, change ..... 200  
 Time, setting ..... 62, 95  
 Time/Distance ..... 91  
 Time ..... 51  
 Tips and tricks, radio ..... 405, 428  
 To close the window ..... 316  
 To unlock with the key ..... 317  
 Tools ..... 522  
 Total value ..... 73  
 Towing brace and towing pin ..... 636  
 Towing ..... 635  
 Traction Control System ..... 133  
 Traction control, setting ..... 64  
 Traction Control, settings ..... 97  
 Trailer brake ..... 29  
 Trailer detection ..... 67  
 Transfer gearbox, maintenance .... 562, 563  
 Transfer gearbox, oil  
 recommendations ..... 562  
 Tridem ..... 165  
 Trip data ..... 73  
 Trip meter ..... 50  
 Turn off the power, ADR ..... 193  
 Turn on the main switch ..... 318  
 Turning off the heater ..... 331  
 Turning off the parking heater ..... 340  
 Turning off the rest heater ..... 342  
 Turntable ..... 502  
 Type plates, location ..... 615  
 Tyre pressure ..... 56  
 Tyres, maintenance ..... 588

**U**

Units, distance ..... 61  
 Units, fuel consumption ..... 62  
 Units, pressure ..... 62  
 Units, setting ..... 95

Units, temperature ..... 62  
 Unlocking ..... 316  
 Up/Down-changing ..... 238  
 Upper bunk ..... 351  
 USB mode, radio ..... 413

**V**

VEB ..... 253  
 Vehicle care ..... 516  
 Vehicle data ..... 72, 287  
 Vehicle ID ..... 72  
 Vehicle Messages ..... 56  
 Vehicle setting ..... 64  
 Vehicle settings ..... 97  
 Voltmeter ..... 47

**W**

Warming up, engine ..... 11  
 Warming up, gearbox ..... 11  
 Warning devices ..... 631  
 Warning messages ..... 35  
 Warning triangles ..... 631  
 Washing the chassis ..... 516  
 Welding ..... 547  
 Wheel ID ..... 57  
 Wheels, maintenance ..... 588  
 Winching up and securing the  
 spare wheel ..... 499  
 Window lifters ..... 316  
 Windscreen wiper ..... 25  
 Windscreen wipers ..... 25  
 Wiper blade, replace ..... 509