

---

## Electrical Circuit Diagrams

**PayStar® 5900**

**Engine Family: MaxxForce® 11/13, 15L, N13 or ISX15 Engines with SCR**

**Navistar, Inc.**

2701 Navistar Drive, Lisle, IL 60532 USA



## TABLE OF CONTENTS

<b>2. INSTRUCTIONS AND CHARTS (CHAPTER 2).....</b>	<b>1</b>
2.1. ABBREVIATIONS, P. 1.....	1
2.2. ACRONYMS, P. 2.....	2
2.3. CIRCUIT DIAGRAM INSTRUCTIONS, P. 3.....	3
2.4. CIRCUIT NUMBER IDENTIFICATION AND COLOR, P. 4.....	4
2.5. CIRCUIT NUMBER IDENTIFICATION AND COLOR (CONT.), P. 5.....	5
2.6. CIRCUIT NUMBER IDENTIFICATION AND COLOR (CONT.), P. 6.....	6
2.7. LAMP BULB CHART, P. 7.....	7
2.8. RELAY FUNCTION AND WIRING GUIDE, P. 8.....	8
2.9. SCHEMATIC SYMBOL CHART, P. 9.....	9
2.10. SCHEMATIC SYMBOL CHART (CONT.), P. 10.....	10
2.11. SCHEMATIC SYMBOL CHART (CONT.), P. 11.....	11
2.12. SCHEMATIC SYMBOL CHART (CONT.), P. 12.....	12
<b>3. 12 VOLT POWER DISTRIBUTION (CHAPTER 3).....</b>	<b>13</b>
3.1. BATTERY FEED WITH ENGINE BRAKE, P. 1.....	13
3.2. BATTERY FEED WITH ENGINE BRAKE WITH 500K BAUD RATE, P. 1A.....	14
3.3. BATTERY FEED WITH ENGINE BRAKE (CONT.), P. 2.....	15
3.4. BATTERY FEED WITH ENGINE BRAKE WITH 500K BAUD RATE (CONT.), P. 2A.....	16
3.5. BATTERY FEED WITH ENGINE BRAKE (CONT.), P. 3.....	17
3.6. BATTERY FEED WITH ENGINE BRAKE WITH 500K BAUD RATE (CONT.), P. 3A.....	18
3.7. BATTERY FEED WITHOUT ENGINE BRAKE, P. 4.....	19
3.8. BATTERY FEED WITHOUT ENGINE BRAKE WITH 500K BAUD RATE, P. 4A.....	20
3.9. BATTERY FEED WITHOUT ENGINE BRAKE, P. 5.....	21
3.10. BATTERY FEED WITHOUT ENGINE BRAKE WITH 500K BAUD RATE (CONT.), P. 5A.....	22
3.11. IGNITION FEED, P. 6.....	23
3.12. IGNITION FEED WITH 500K BAUD RATE, P. 6A.....	24
3.13. IGNITION FEED (CONT.), P. 7.....	25
3.14. IGNITION FEED WITH 500K BAUD RATE (CONT.), P. 7A.....	26
3.15. POWER FEED, P. 8.....	27
3.16. ACCESSORY FEED, P. 9.....	28
3.17. ACCESSORY FEED WITH 500K BAUD RATE, P. 9A.....	29
3.18. J1939 DATA LINK WITH IBB ENGINE, P. 10.....	30
3.19. J1939 DATA LINK WITH IBB ENGINE (CONT.), P. 11.....	31
3.20. J1939 DATA LINK WITH IBB ENGINE (CONT.), P. 11A.....	32
3.21. DIAGNOSTIC DATA LINK, P. 12.....	33
3.22. GROUND, P. 13.....	34
3.23. GROUND (CONT.), P. 14.....	35
3.24. GROUND (CONT.), P. 15.....	36
3.25. GROUND (CONT.), P. 16.....	37
3.26. GROUND CHASSIS, P. 16A.....	38
3.27. ZERO VOLT REFERENCE, P. 17.....	39
3.28. PANEL LIGHT ADAPTER, P. 18.....	40
3.29. ECA POWER, P. 19.....	41
3.30. J1939 DATA LINK WITH 15L ISX 2013, P. 20.....	42
3.31. CAB J1939 DATA LINK WITH 11 / 13L IBB SCR, P. 21.....	43
3.32. ECM SWITCH GND SPLICE, P. 22.....	44
3.33. ECM SWITCH GND SPLICE 2, P. 23.....	45
3.34. 250K J1939 CAB DATA LINK WITH 500K REGULATORY UPDATE, P. 24.....	46
3.35. J1939 DATA LINK WITH 500K BAUD RATE (CONT.), P. 25.....	47

## TABLE OF CONTENTS (CONT.)

<b>4. CAB ACCESSORIES (CHAPTER 4)</b> .....	<b>48</b>
4.1. CIGAR LIGHTER, P. 1.....	48
4.2. ELECTRIC WINDOW – RIGHT AND LEFT, P. 2.....	49
4.3. ELECTRIC WINDOW – RIGHT, P. 3.....	50
4.4. DEFROSTER FAN(S), P. 4.....	51
4.5. HORN, P. 5.....	52
4.6. MIRROR LIGHTS AND HEATED MIRRORS, P. 6.....	53
4.7. LEFT AND RIGHT MOTORIZED MIRRORS, P. 7.....	54
4.8. DUAL AXIS MOTORIZED MIRRORS, P. 8.....	55
4.9. POWER SOURCE (CB), P. 9.....	56
4.10. RADIO - CB ACCOMMODATION PACKAGE, P. 10.....	57
4.11. RADIO – CAB SPEAKERS, P. 11.....	58
4.12. ELECTRIC LOCK – RIGHT AND LEFT, P. 12.....	59
4.13. TEMPERATURE / COMPASS DISPLAY, P. 13.....	60
4.14. ROAD RELAY IV, P. 14.....	61
4.15. HEATED SEAT – DRIVER, P. 15.....	62
4.16. HEATED SEAT – PASSENGER, P. 16.....	63
4.17. ELECTRIC WINDSHIELD WIPER WITH INTERMITTENT WIPE AND WASH, P. 17.....	64
4.18. DEF GAUGE, P. 18.....	65
4.19. HEWITT MOTION SENSOR, P. 19.....	66
<b>5. CHARGING AND CRANKING (CHAPTER 5)</b> .....	<b>67</b>
5.1. STARTER INTERLOCK WITH IBB ENGINES, P. 1.....	67
5.2. STARTER INTERLOCK WITH IBB ENGINES WITH 500K BAUD RATE, P. 1A.....	68
5.3. STARTER INTERLOCK WITH IBB ENGINES, P. 2.....	69
5.4. STARTER INTERLOCK WITH IBB ENGINES, P. 2A.....	70
<b>6. FANS WIRING (CHAPTER 6)</b> .....	<b>71</b>
6.1. FAN WIRING – IBB ENGINE, P. 1.....	71
6.2. FAN WIRING – IBB ENGINE (CONT.), P. 1A.....	72
6.3. FAN WIRING – IBB ENGINE (CONT.), P. 2.....	73
<b>7. ENGINE SYSTEMS (CHAPTER 7)</b> .....	<b>74</b>
7.1. ELECTRONIC ENGINE CONTROLS (2010 IBB ENGINE), P. 1.....	74
7.2. ELECTRONIC ENGINE CONTROLS (2010 IBB ENGINE) (CONT.), P. 2.....	75
7.3. ELECTRONIC ENGINE CONTROLS (2010 IBB ENGINE) (CONT.), P. 3.....	76
7.4. ELECTRONIC ENGINE CONTROLS (2010 IBB ENGINE) (CONT.), P. 3A.....	77
7.5. ELECTRONIC ENGINE CONTROLS (2010 IBB ENGINE) (CONT.), P. 4.....	78
7.6. FAN DRIVE PROTECTION JUMPER, P. 4A.....	79
7.7. ELECTRONIC ENGINE CONTROLS (2010 IBB ENGINE) (CONT.), P. 5.....	80
7.8. ELECTRONIC ENGINE CONTROLS (2010 IBB ENGINE) (CONT.), P. 6.....	81
7.9. ELECTRONIC ENGINE CONTROLS (2010 IBB ENGINE) (CONT.), P. 7.....	82
7.10. ELECTRONIC ENGINE CONTROLS (2010 IBB ENGINE) (CONT.), P. 8.....	83
7.11. AFTERTREATMENT CONTROL, P. 9.....	84
7.12. SART MODULE, P. 9A.....	85
7.13. AFTERTREATMENT CONTROL (CONT.), P. 10.....	86
7.14. AFTERTREATMENT CONTROL WITH 500K BAUD RATE, P. 10A.....	87
7.15. AFTERTREATMENT CONTROL WITH 500K BAUD RATE (CONT.), P. 10B.....	88
7.16. ELECTRONIC ENGINE CONTROLS (15L ENG) ISX 2013, P. 11.....	89
7.17. ELECTRONIC ENGINE CONTROLS (15L ENG) ISX 2013 (CONT.), P. 12.....	90
7.18. 15L ENG & CRUISE CONTROL – ISX 2013, P. 13.....	91

**TABLE OF CONTENTS (CONT.)**

7.19.	ELECTRONIC ENGINE CONTROLS (IBB ENGINE) – SCR EFFECTS, P. 14.....	92
7.20.	ELECTRONIC ENGINE CONTROLS (IBB ENGINE) – SCR EFFECTS (CONT.), P. 15.....	93
7.21.	ELECTRONIC ENGINE CONTROLS (IBB ENGINE) – SCR EFFECTS (CONT.), P. 16.....	94
7.22.	ELECTRONIC ENGINE CONTROLS (IBB ENGINE) – SCR EFFECTS (CONT.), P. 17.....	95
7.23.	11L / 13L IBB ENG CRUISE CONTROL – SCR EFFECTS, P. 18.....	96
7.24.	ISX 2013 DEF & AFTERTREATMENT (15L), P. 19.....	97
7.25.	ISX 2013 DEF & AFTERTREATMENT (15L) (CONT.), P. 20.....	98
7.26.	ISX 2013 DEF & AFTERTREATMENT (15L) (CONT.), P. 21.....	99
7.27.	ISX 2013 DEF & AFTERTREATMENT (15L) (CONT.), P. 22.....	100
7.28.	ISX 2013 DEF & AFTERTREATMENT (15L) (CONT.), P. 23.....	101
7.29.	DEF & AFTERTREATMENT (IBB SCR ENG), P. 24.....	102
7.30.	DEF & AFTERTREATMENT (IBB SCR ENG) (CONT.), P. 25.....	103
7.31.	15L ISX & IBB SCR ENG THROTTLE POSITION, P. 26.....	104
7.32.	DEF & AFTERTREATMENT (SCR ENGINE), P. 27.....	105
7.33.	DEF & AFTERTREATMENT (SCR ENGINE) (CONT.), P. 27A.....	106
7.34.	DEF & AFTERTREATMENT (SCR ENGINE) (CONT.), P. 28.....	107
7.35.	DEF & AFTERTREATMENT (SCR ENGINE) (CONT.), P. 29.....	108
<b>8.</b>	<b>GAUGES AND WARNING LIGHTS (CHAPTER 8).....</b>	<b>109</b>
8.1.	LOW FUEL LEVEL WARNING, LOW AIR PRESSURE WARNING LIGHTS, P. 1.....	109
8.2.	ENGINE OIL PRESSURE, ENGINE WATER TEMPERATURE WARNING LIGHTS, ENGINE AMBIENT AIR TEMP, P. 2.....	110
8.3.	POWER DIVIDER LOCK (PDL) WARNING LIGHT AND BUZZER, IBB WAIT TO START LIGHT, P. 3.....	111
8.4.	AIR SUSPENSION RELEASE WARNING LIGHT, P. 4.....	112
8.5.	TRANSMISSION OIL TEMPERATURE GAUGE, AXLE FORWARD-REAR AND REAR-REAR TEMPERATURE GAUGE, P. 5.....	113
8.6.	MANIFOLD PRESSURE GAUGE, P. 6.....	114
8.7.	PYROMETER GAUGE, P. 7.....	115
8.8.	VOLTMETER AND FUEL LEVEL GAUGE, P. 8.....	116
8.9.	ENGINE WATER TEMPERATURE, ENGINE OIL PRESSURE, SPEEDOMETER AND TACHOMETER GAUGE, P. 9.....	117
8.10.	ETHER START, P. 10.....	118
8.11.	RED STOP LAMP BUZZER SYSTEM, P. 11.....	119
<b>9.</b>	<b>LIGHTING SYSTEM (CHAPTER 9).....</b>	<b>120</b>
9.1.	BACKUP LIGHTS, P. 1.....	120
9.2.	CAB AND TRAILER LIGHT SWITCH AND RELAY, P. 2.....	121
9.3.	CAB CLEARANCE LIGHTS, P. 3.....	122
9.4.	WORK LIGHT WITHOUT SLEEPER, P. 4.....	123
9.5.	CAB DOME, READING AND COURTESY LIGHTS, P. 5.....	124
9.6.	DAYTIME RUNNING LIGHTS, P. 6.....	125
9.7.	FOG LIGHTS, P. 7.....	126
9.8.	HEADLIGHT SWITCH AND DIMMER SWITCH, P. 8.....	127
9.9.	HEADLIGHTS, P. 9.....	128
9.10.	HEADLIGHTS (CONT.), P. 9A.....	129
9.11.	PANEL LIGHTS, P. 10.....	130
9.12.	PARK / TURN / SIDE MARKER LIGHTS WITH AUXILIARY HEADLIGHTS, P. 11.....	131
9.13.	STOP, TAIL, TURN AND HAZARD SIGNAL LIGHTS WITH FLASHER, P. 12.....	132
9.14.	BEACON LIGHT, P. 13.....	133

**TABLE OF CONTENTS (CONT.)**

<b>10. CHASSIS ACCESSORIES (CHAPTER 10)</b> .....	<b>134</b>
10.1. AIR DRYER, P. 1.....	134
10.2. BENDIX AIR ABS 4CH WITH ATC, P. 2.....	135
10.3. BENDIX AIR ABS 4CH WITH ATC, P. 3.....	136
10.4. BENDIX AIR ABS 4CH WITH ATC WITH HSA, P. 4.....	137
10.5. BENDIX AIR ABS 4CH WITH ATC, P. 5.....	138
10.6. BENDIX AIR ABS 6CH WITH ATC, P. 6.....	139
10.7. BENDIX AIR ABS 6CH WITH ATC, P. 7.....	140
10.8. BENDIX AIR ABS 6CH WITH ATC WITH HSA, P. 8.....	141
10.9. BENDIX AIR ABS 6CH WITH ATC, P. 9.....	142
10.10. ABS BENDIX AIR 6S / 6M (6X4), P. 10.....	143
10.11. BENDIX AIR ABS WITH ATC, P. 11.....	144
10.12. BENDIX ADVANCE AIR ABS, P. 12.....	145
10.13. BENDIX ADVANCE AIR ABS (CONT.), P. 13.....	146
10.14. BENDIX ADVANCE AIR ABS (CONT.), P. 14.....	147
10.15. BENDIX ADVANCE AIR ABS FOR 6CH, P. 15.....	148
10.16. TRAILER CONNECTION WITH FOUR WHEEL TRAILER FRAME MOUNTED, P. 16.....	149
10.17. TRUCK BODY CONNECTION, P. 17.....	150
10.18. TRAILER CONNECTION WITHOUT SLEEPER BACK OF CAB MOUNTED WITH TRACTOR ABS, P. 18.....	151
10.19. INTENTIONALLY LEFT BLANK, P. 19.....	152
10.20. INTENTIONALLY LEFT BLANK, P. 20.....	153
10.21. INTENTIONALLY LEFT BLANK, P. 21.....	154
10.22. INTENTIONALLY LEFT BLANK, P. 22.....	155
10.23. APADS MODULE FOR ISX 2013 ENGINES, P. 23.....	156
10.24. BODY BUILDER CONNECTIONS WITH IBB ENG (SCR EFFECTS), P. 24.....	157
10.25. BODY BUILDER CONNECTIONS WITH 15L ENG (ISX 2013), P. 25.....	158
10.26. TRI AXLE DIFFERENTIAL LOCK, P. 26.....	159
<b>11. TRANSMISSION CONTROL MODULE (CHAPTER 11)</b> .....	<b>160</b>
11.1. ALLISON TRANSMISSION, P. 1.....	160
11.2. ALLISON TRANSMISSION (CONT.), P. 1A.....	161
11.3. ALLISON TRANSMISSION (CONT.), P. 2.....	162
11.4. ALLISON TRANSMISSION (CONT.), P. 3.....	163
11.5. ALLISON TRANSMISSION (CONT.), P. 3A.....	164
11.6. ALLISON TRANSMISSION WITH AUTO NEUTRAL, P. 4.....	165
11.7. ALLISON TRANSMISSION WITH AUTO NEUTRAL (CONT.), P. 4A.....	166
11.8. ALLISON TRANSMISSION WITH RETARDER, P. 5.....	167
11.9. ALLISON TRANSMISSION WITH RETARDER (CONT.), P. 6.....	168
11.10. ALLISON TRANSMISSION WITH RETARDER (CONT.), P. 7.....	169
11.11. ALLISON TRANSMISSION WITH RETARDER (CONT.), P. 7A.....	170
11.12. ALLISON TRANSMISSION WITH RETARDER (CONT.), P. 7B.....	171
11.13. ALLISON TRANSMISSION WITH RETARDER (CONT.), P. 7C.....	172
11.14. ALLISON TRANSMISSION WITH RETARDER (CONT.), P. 7D.....	173
11.15. EATON ULTRASHIFT GEN III TRANSMISSION, P. 8.....	174
11.16. EATON ULTRASHIFT PLUS GEN III TRANSMISSION, P. 8A.....	175
11.17. EATON ULTRASHIFT GEN III TRANSMISSION (CONT.), P. 9.....	176
11.18. EATON ULTRASHIFT PLUS GEN III TRANSMISSION (CONT.), P. 9A.....	177
11.19. EATON ULTRASHIFT GEN III WITH PUSHBUTTON SHIFT, P. 10.....	178
11.20. EATON ULTRASHIFT GEN III WITH PUSHBUTTON SHIFT, P. 10A.....	179
11.21. AUTOSHIFT GEN III WITH COBRA SHIFTER, P. 11.....	180

## TABLE OF CONTENTS (CONT.)

11.22. EATON ULTRASHIFT PLUS GEN III WITH COBRA SHIFTER, P. 11A.....	181
11.23. ALLISON TRANSMISSION WITH RETARDER WITH ISX ENGINE, P. 12.....	182
11.24. ALLISON TRANSMISSION WITH 500K CAN BUS, P. 12A.....	183
11.25. ALLISON TRANSMISSION WITH RETARDER WITH ISX ENGINE (CONT.), P. 13.....	184
<b>12. HVAC (CHAPTER 12).....</b>	<b>185</b>
12.1. AIR CONDITIONER – CAB, P. 1.....	185
12.2. HEATER – CAB, P. 2.....	186
12.3. LOWERED HEATER – CAB, P. 3.....	187
<b>13. CONNECTOR COMPOSITES (CHAPTER 13).....</b>	<b>188</b>
13.1. CONNECTOR COMPOSITES (1), P. 1.....	188
13.2. CONNECTOR COMPOSITES (2 / 2M), P. 2.....	189
13.3. CONNECTOR COMPOSITES (2), P. 2A.....	190
13.4. CONNECTOR BODY COMPOSITE (2), P. 2B.....	191
13.5. CONNECTOR COMPOSITES (3F / 3M), P. 3.....	192
13.6. CONNECTOR COMPOSITES (4M / 5 / 9 / 15M), P. 4.....	193
13.7. CONNECTOR COMPOSITES (20 / 40M / 41M / 43M / 65 / 65F), P. 5.....	194
13.8. CONNECTOR COMPOSITES (66F / 71 / 72 / 76M), P. 6.....	195
13.9. CONNECTOR COMPOSITES (77 / 82 / 83F / 90M / 100 / 100A), P. 7.....	196
13.10. CONNECTOR COMPOSITES (100), P. 8.....	197
13.11. CONNECTOR COMPOSITES (100F / 101F / 102F / 100M3), P. 8A.....	198
13.12. CONNECTOR COMPOSITES (105), P. 9.....	199
13.13. CONNECTOR COMPOSITES (105F), P. 10.....	200
13.14. CONNECTOR COMPOSITES (105M), P. 10A.....	201
13.15. CONNECTOR COMPOSITES (106F / 107M / 108F), P. 11.....	202
13.16. CONNECTOR COMPOSITES (108M), P. 12.....	203
13.17. CONNECTOR COMPOSITES (112 / 113 / 115), P. 13.....	204
13.18. CONNECTOR COMPOSITES (127A / 128 / 137M / 141F), P. 14.....	205
13.19. CONNECTOR COMPOSITES (141F / 142M / 143M / 144M), P. 15.....	206
13.20. CONNECTOR COMPOSITES (145M / 146M / 147M), P. 16.....	207
13.21. CONNECTOR COMPOSITES (148M / 149M / 152M), P. 17.....	208
13.22. CONNECTOR COMPOSITES (152M / 153A / 153M / 161M / 162F), P. 18.....	209
13.23. CONNECTOR COMPOSITES (165 / 167M / 170M / 171M), P. 19.....	210
13.24. CONNECTOR COMPOSITES (190), P. 20.....	211
13.25. CONNECTOR COMPOSITES (200M / 201M), P. 21.....	212
13.26. CONNECTOR COMPOSITES (201M / 202M / 203 / 203G), P. 22.....	213
13.27. CONNECTOR COMPOSITES (201M / 204 / 205), P. 22A.....	214
13.28. CONNECTOR COMPOSITES (205G / 205M), P. 22B.....	215
13.29. CONNECTOR COMPOSITES (209 / 211M / 214 / 221), P. 23.....	216
13.30. CONNECTOR COMPOSITES (227 / 228 / 230 / 236 / 236F / 244F), P. 24.....	217
13.31. CONNECTOR COMPOSITES (267M / *275 / 289F / 290F / 291), P. 25.....	218
13.32. CONNECTOR COMPOSITES (291F / 292F / 294A / 294F), P. 26.....	219
13.33. CONNECTOR COMPOSITES (296M / 298 / 299 / 303F), P. 27.....	220
13.34. CONNECTOR COMPOSITES (303M / 311 / 312 / 313 / 314M), P. 28.....	221
13.35. CONNECTOR COMPOSITES (320 / 325 / 340), P. 29.....	222
13.36. CONNECTOR COMPOSITES (345M / 351 / 352), P. 29A.....	223
13.37. CONNECTOR COMPOSITES (353 / 354 / 355), P. 30.....	224
13.38. CONNECTOR COMPOSITES (360 / 393 / 393B / 412A / 420M), P. 31.....	225
13.39. CONNECTOR COMPOSITES (421M / 422M), P. 32.....	226
13.40. CONNECTOR COMPOSITES (423M / 424M), P. 33.....	227

## TABLE OF CONTENTS (CONT.)

13.41. CONNECTOR COMPOSITES (425M / 426 / 426M / 427 / 480F), P. 34.....	228
13.42. CONNECTOR COMPOSITES (428F / 429F / 430), P. 35.....	229
13.43. CONNECTOR COMPOSITES (433M / 434M / 435M), P. 36.....	230
13.44. CONNECTOR COMPOSITES (436M / 437M / 438M / 440M), P. 37.....	231
13.45. CONNECTOR COMPOSITES (441 / 442 / 453M), P. 38.....	232
13.46. CONNECTOR COMPOSITES (454M / 455M), P. 39.....	233
13.47. CONNECTOR COMPOSITES (456M / 457M / 460F), P. 40.....	234
13.48. CONNECTOR COMPOSITES (462M), P. 41.....	235
13.49. CONNECTOR COMPOSITES (462M), P. 42.....	236
13.50. CONNECTOR COMPOSITES (462M), P. 43.....	237
13.51. CONNECTOR COMPOSITES (462M), P. 44.....	238
13.52. CONNECTOR COMPOSITES (463M), P. 45.....	239
13.53. CONNECTOR COMPOSITES (463M), P. 46.....	240
13.54. CONNECTOR COMPOSITES (464M), P. 47.....	241
13.55. CONNECTOR COMPOSITES (464M), P. 48.....	242
13.56. CONNECTOR COMPOSITES (464M), P. 49.....	243
13.57. CONNECTOR COMPOSITES (464M), P. 50.....	244
13.58. CONNECTOR COMPOSITES (464M), P. 51.....	245
13.59. CONNECTOR COMPOSITES (464M), P. 52.....	246
13.60. CONNECTOR COMPOSITES (465M / 466M / 468F / 469ML), P. 53.....	247
13.61. CONNECTOR COMPOSITES (471), P. 54.....	248
13.62. CONNECTOR COMPOSITES (471), P. 55.....	249
13.63. CONNECTOR COMPOSITES (471), P. 55A.....	250
13.64. CONNECTOR COMPOSITES (471), P. 55B.....	251
13.65. CONNECTOR COMPOSITES (471A), P. 55C.....	252
13.66. CONNECTOR COMPOSITES (471AF / 480F / 480M / 481M / 482M / 489), P. 56.....	253
13.67. CONNECTOR COMPOSITES (491F / 492M / 494M), P. 57.....	254
13.68. CONNECTOR COMPOSITES (495M / 497M), P. 58.....	255
13.69. CONNECTOR COMPOSITES (498M / 499M), P. 59.....	256
13.70. CONNECTOR COMPOSITES (501M / 503M), P. 60.....	257
13.71. CONNECTOR COMPOSITES (504M / 506M), P. 61.....	258
13.72. CONNECTOR COMPOSITES (509M / 511M / 512F), P. 62.....	259
13.73. CONNECTOR COMPOSITES (513M / 514M), P. 63.....	260
13.74. CONNECTOR COMPOSITES (515M / 517M / 520 / 521), P. 64.....	261
13.75. CONNECTOR COMPOSITES (522 / 523 / 524 / 528 / 529), P. 65.....	262
13.76. CONNECTOR COMPOSITES (530 / 531 / 562M / 600M), P. 66.....	263
13.77. CONNECTOR COMPOSITES (608 / 640 / 649M / 659M / 662M / 665B), P. 67.....	264
13.78. CONNECTOR COMPOSITES (668M / 670 / 670A), P. 67A.....	265
13.79. CONNECTOR COMPOSITES (670G / *671 / 671A / 672 / 673), P. 67B.....	266
13.80. CONNECTOR COMPOSITES (674), P. 67C.....	267
13.81. CONNECTOR COMPOSITES (674D / 674E / 675 / 676), P. 67D.....	268
13.82. CONNECTOR COMPOSITES (677 / 678 / 679), P. 67E.....	269
13.83. CONNECTOR COMPOSITES (*679 / 680), P. 67F.....	270
13.84. CONNECTOR COMPOSITES (*680 / *681), P. 67G.....	271
13.85. CONNECTOR COMPOSITES (685), P. 67H.....	272
13.86. CONNECTOR COMPOSITES (686 / 687), P. 67I.....	273
13.87. CONNECTOR COMPOSITES (690 / 691 / 694M), P. 68.....	274
13.88. CONNECTOR COMPOSITES (695F / 723M / 741F / 742F / 753), P. 69.....	275
13.89. CONNECTOR COMPOSITES (766 / 768 / 769), P. 70.....	276
13.90. CONNECTOR COMPOSITES (770 / 771 / 774 / 775), P. 71.....	277
13.91. CONNECTOR COMPOSITES (776 / 777 / 778 / 800F), P. 72.....	278



## TABLE OF CONTENTS (CONT.)

13.92. CONNECTOR COMPOSITES (800M / 808M / 809F), P. 73.....	279
13.93. CONNECTOR COMPOSITES (823M / 851 / *851M / 854), P. 74.....	280
13.94. CONNECTOR COMPOSITES (873 / 875M / 876M / 878F), P. 75.....	281
13.95. CONNECTOR COMPOSITES (879M / 881F / 884F / 887), P. 76.....	282
13.96. CONNECTOR COMPOSITES (887M / 907M / 931F), P. 76A.....	283
13.97. CONNECTOR COMPOSITES (922M / 923F / 925), P. 77.....	284
13.98. CONNECTOR COMPOSITES (926 / 934M / 935), P. 78.....	285
13.99. CONNECTOR COMPOSITES (946 / 950 / 950F), P. 79.....	286
13.100. CONNECTOR COMPOSITES (958 / 958F / 961), P. 80.....	287
13.101. CONNECTOR COMPOSITES (1000 / 1027), P. 81.....	288
13.102. CONNECTOR COMPOSITES (1033F / 1034F / 1039 / 1040), P. 82.....	289
13.103. CONNECTOR COMPOSITES (1041 / 1042 / 1043 / 1044), P. 83.....	290
13.104. CONNECTOR COMPOSITES (1045 / 1046 / 1047 / 1048F), P. 84.....	291
13.105. CONNECTOR COMPOSITES (1049F / 1050M / 1051 / 1052 / 1054M), P. 85.....	292
13.106. CONNECTOR COMPOSITES (1056M / 1057M / 1058M / 1059M / 1060M), P. 86.....	293
13.107. CONNECTOR COMPOSITES (1065M / 1085M / 1087M / 1090 / 1095F), P. 87.....	294
13.108. CONNECTOR COMPOSITES (1095F / 1097 / 1097F / 1098F), P. 88.....	295
13.109. CONNECTOR COMPOSITES (1099 / 1110 / 1125 / 1126), P. 89.....	296
13.110. CONNECTOR COMPOSITES (1127 / 1128), P. 90.....	297
13.111. CONNECTOR COMPOSITES (1135M / 1137), P. 90A.....	298
13.112. CONNECTOR COMPOSITES (1157F / 1158M / 1160F / 1161F, 1162F, 1163F, 1164F), P. 91.....	299
13.113. CONNECTOR COMPOSITE (1171M / 1190 / 1190F), P. 91A.....	300
13.114. CONNECTOR COMPOSITES (1217M / 1240 / 1258F / 1260F / 1262), P. 92.....	301
13.115. CONNECTOR COMPOSITES (1281M / 1282M / 1283 / 1284 / 1285F), P. 93.....	302
13.116. CONNECTOR COMPOSITES (1286F / 1308 / 1309M / 1329M / 1330 / 1331F / 1332F), P. 94.....	303
13.117. CONNECTOR COMPOSITES (1329M / 1330 / 1331F / 1332F), P. 94A.....	304
13.118. CONNECTOR COMPOSITES (1339 / 1342 / 1348), P. 95.....	305
13.119. CONNECTOR COMPOSITES (1349 / 1350), P. 96.....	306
13.120. CONNECTOR COMPOSITES (1351 / 1360), P. 96A.....	307
13.121. CONNECTOR COMPOSITES (1361 / 1363 / 1364), P. 97.....	308
13.122. CONNECTOR COMPOSITES (1366 / 1367 / 1368F / 1369), P. 98.....	309
13.123. CONNECTOR COMPOSITES (1370 / 1378 / 1386 / 1387), P. 99.....	310
13.124. CONNECTOR COMPOSITES (1402 / 1403 / 1404 / 1405), P. 99A.....	311
13.125. CONNECTOR COMPOSITES (1406 / 1407 / 1415), P. 99B.....	312
13.126. CONNECTOR COMPOSITES (1431 / 1449F / 1449M / 1450 / 1451 / 1455 / 1456 / 1461M / 1610), P. 99C.....	313
13.127. CONNECTOR COMPOSITES (1600 / 1601), P. 99D.....	314
13.128. CONNECTOR COMPOSITES (1602 / 1604 / 1606 / 1610), P. 99E.....	315
13.129. CONNECTOR COMPOSITES (1874A / 1874B / 1874C / 1874D / 2000M / 4322 / 4328), P. 99F.....	316
13.130. CONNECTOR COMPOSITES (4087 / 4705 / 4706), P. 99G.....	317
13.131. CONNECTOR COMPOSITES (5501 / 5701L / 6000), P. 100.....	318
13.132. CONNECTOR COMPOSITES (6000 / 6001), P. 101.....	319
13.133. CONNECTOR COMPOSITES (6018), P. 102.....	320
13.134. CONNECTOR COMPOSITES (6019), P. 103.....	321
13.135. CONNECTOR COMPOSITES (6033 / 6200 / 6195), P. 104.....	322
13.136. CONNECTOR COMPOSITES (6260VH / 6260VL / 6260VM / 6260VN / 6401 / 6300), P. 105.....	323
13.137. CONNECTOR COMPOSITES (6420 / 6703 / 6704B / 6704D), P. 106.....	324

## TABLE OF CONTENTS (CONT.)

13.138.CONNECTOR COMPOSITES (6705B / 6715), P. 107.....	325
13.139.CONNECTOR COMPOSITES (6720 / 6720A), P. 108.....	326
13.140.CONNECTOR COMPOSITES (6720B / 6730 / 6748 / 7000), P. 109.....	327
13.141.CONNECTOR COMPOSITES (7104 / 7001), P. 110.....	328
13.142.CONNECTOR COMPOSITES (7105 / 7110), P. 111.....	329
13.143.CONNECTOR COMPOSITES (7150), P. 112.....	330
13.144.CONNECTOR COMPOSITES (7211 / 7212 / 7213 / 7250), P. 113.....	331
13.145.CONNECTOR COMPOSITES (7500W / 7501 / 7600 / 7601 / 7603 / 7608), P. 114.....	332
13.146.CONNECTOR COMPOSITES (7615 / 7704 / 7905), P. 115.....	333
13.147.CONNECTOR COMPOSITES (8102 / 8103 / 8104 / 8107 / 8410), P. 116.....	334
13.148.CONNECTOR COMPOSITES (8500 / 9762 / 9763 / 9764 / 9765 / 9766), P. 117.....	335
13.149.CONNECTOR COMPOSITES (351A / 352A / 353A / 354A), P. 118.....	336
13.150.CONNECTOR COMPOSITES (445 / 453 / 580M / 690A), P. 119.....	337
13.151.CONNECTOR COMPOSITES (1362 / 9510F / 9513), P. 120.....	338

## INSTRUCTIONS AND CHARTS (CHAPTER 2)

### 2.1. ABBREVIATIONS, P. 1

<b>NAVISTAR, INC</b>				<b>ELECTRICAL CIRCUIT DIAGRAM</b>	
THIS PRINT IS PROVIDED ON A RESTRICTED BASIS AND IS NOT TO BE USED IN ANY WAY DETRIMENTAL TO THE INTEREST OF NAVISTAR, INC.				<b>CHAPTER 2</b>	
				ABBREVIATIONS	
ABBREVIATION	DESCRIPTION	ABBREVIATION	DESCRIPTION	ABBREVIATION	DESCRIPTION
ACCESS	ACCESSORY	CUR	CURRENT	PRESS	PRESSURE
AC	AIR CONDITIONING	DPNL	DASHBOARD	RAD	RADIO
AIR CLNR	AIR CLEANER	DFTR	DEFLECTOR	RR	REAR
ALT	ALTERNATOR	DFR	DEFROSTER	RLY	RELAY
AC	ALTERNATING CURRENT	DEG	DEGREE	RES	RESISTOR
AFTR	AFTERTREATMENT	DIAG	DIAGRAM	R	RIGHT
AMM	AMMETER	DSL	DIESEL	RTR	ROTOR
AMP	AMPERE	DIFF	DIFFERENTIAL	SNSR	SENSOR
AMP HR	AMPERE HOUR	DIMR	DIMMER	SHLD	SHIELD
AMPL	AMPLIFIER	ELEC	ELECTRICAL	SHFT	SHIFTER
ARM	ARMATURE	ELEX	ELECTRONICS	SLPR	SLEEPER
ARSR	ARRESTER	ENG	ENGINE	SLV	SLEEVE
ASSY	ASSEMBLY	EXH	EXHAUST	SPKR	SPEAKER
AUX	AUXILIARY	FL	FLUID	SPR	SPRING
B/U	BACK-UP	FWD	FORWARD	STD	STANDARD
BTRY	BATTERY	FR	FRONT	STRG	STEERING
BM	BENCHMARKING	FREQ	FREQUENCY	STLITE	SATELLITE
BLK	BLOCK	GA	GAUGE	SUNSH	SUNSHADE
BOOS	BOOSTER	GEN	GENERATOR	SW	SWITCH
BOT	BOTTOM	GND	GROUND	SYS	SYSTEM
BK	BRAKE	HARN	HARNESS	TACH	TACHOMETER
BRKR	BREAKER	HDLP	HEADLAMP	TEMP	TEMPERATURE
BRTHR	BREATHER	HTD	HEATED	TERM	TERMINAL
BRI	BRIGHT	HT TR	HEAT TREAT	THROT	THROTTLE
BUZ	BUZZER	HTR	HEATER	THRU	THROUGH
CA	CABLE	HP	HORSEPOWER	TRLR	TRAILER
CD	CANDELA	HYD	HYDRAULIC	XDCR	TRANSDUCER
CP	CANDLEPOWER	ID	IDENTIFICATION	XFER	TRANSFER
CAP	CAPACITOR	IGN	IGNITION	XFMR	TRANSFORMER
CAT	CATERPILLAR	ILLUM	ILLUMINATION	XSTR	TRANSISTOR
CHAS	CHASSIS	IND	INDICATOR	XMSN	TRANSMISSION
CH	CHOKE	INST	INSTRUMENT	XMTR	TRANSMITTER
CIRC	CIRCUIT	INT	INTERMITTENT	TRK	TRUCK
CLK	CLOCK	L	LEFT	UPR	UPPER
CW	CLOCKWISE	LT	LIGHT	VLV	VALVE
CLSTR	CLUSTER	LTR	LIGHTER	VERT	VERTICAL
CL	CLUTCH	LWR	LOWER	VM	VOLTMETER
COL	COLUMN	MAG	MAGNET	VOL	VOLUME
COMM	COMMUTATOR	MOD	MODULATOR	WSHR	WASHER
CMPNT	COMPONENT	MDL	MODULE	WHL	WHEEL
CPRSR	COMPRESSOR	MOT	MOTOR	WDO	WINDOW
CONN	CONNECT	MTD	MOUNTED	WSHLD	WINDSHIELD
CONT	CONTINUED	NEG	NEGATIVE	WPR	WIPER
CSL	CONSOLE	N/	NOT WITH	W/	WITH
CONT	CONTACT	NO.	NUMBER	W/O	WITHOUT
CONT	CONTROL	PASS	PASSENGER		
CONV	CONVERTER	POSN	POSITION		
CLR	COOLER	POS	POSITIVE		
CTSY	COURTESY	POT	POTENTIOMETER		
CRUS	CRUISE	PWR	POWER		

CHK	DATE	CHANGE	REV	REFERENCE	DRAWN	NAME	
DLV1	11JAN11	INITIAL RELEASE.	A	61879Y	300011	CIRCUIT DIAGRAM, PAYSTAR	
					RELEASE NO.	DATE	PART NO. SHEET
					61879Y	12MAY09	AE08058081 001

Figure 1 Abbreviations

2.2. ACRONYMS, P. 2

NAVISTAR, INC				ELECTRICAL CIRCUIT DIAGRAM CHAPTER 2																																																																																																																																							
THIS PRINT IS PROVIDED ON A RESTRICTED BASIS AND IS NOT TO BE USED IN ANY WAY DETRIMENTAL TO THE INTEREST OF NAVISTAR, INC.				ACRONYMS																																																																																																																																							
<table border="1" style="width: 100%; border-collapse: collapse;"> <thead> <tr> <th style="width: 80%;">DESCRIPTION</th> <th style="width: 20%;">ACRONYM</th> </tr> </thead> <tbody> <tr><td>ANTILOCK BRAKING SYSTEM</td><td>ABS</td></tr> <tr><td>ANTENNA COMMUNICATION UNIT</td><td>ACU</td></tr> <tr><td>ALTERNATING CURRENT</td><td>AC</td></tr> <tr><td>AXLE TO BACK OF CAB</td><td>AC</td></tr> <tr><td>AXLE TO FRAME</td><td>AF</td></tr> <tr><td>ACCELERATOR PEDAL MODULE</td><td>APM</td></tr> <tr><td>ACCELERATOR POSITION SENSOR</td><td>APS</td></tr> <tr><td>AUXILIARY POWER UNIT</td><td>APU</td></tr> <tr><td>AUTOMATIC TRACTION CONTROL</td><td>ATC</td></tr> <tr><td>AUDIO VIDEO INTERFACE</td><td>AVI</td></tr> <tr><td>BRAKE HORSEPOWER</td><td>BHP</td></tr> <tr><td>BACK OF CAB</td><td>BOC</td></tr> <tr><td>CITIZEN BAND</td><td>CB</td></tr> <tr><td>COLD CRANKING AMPERES</td><td>CCA</td></tr> <tr><td>CLEAN POWER ELECTRICAL CONNECTOR</td><td>CEC</td></tr> <tr><td>CAB OVER ENGINE</td><td>COE</td></tr> <tr><td>DIRECT CURRENT</td><td>DC</td></tr> <tr><td>DRIVER CONTROL MODULE</td><td>DCM</td></tr> <tr><td>DIGITAL DATA LINK</td><td>DDL</td></tr> <tr><td>DIESEL OXIDATION CATALYST INLET TEMPERATURE</td><td>DOCT</td></tr> <tr><td>DIESEL PARTICULATE FILTER</td><td>DPF</td></tr> <tr><td>DIESEL TURBOCHARGED</td><td>DT</td></tr> <tr><td>DAY TIME RUNNING LIGHTS</td><td>DTRL</td></tr> <tr><td>ELECTRONIC CONTROL MODULE</td><td>ECM</td></tr> <tr><td>ELECTRONIC CONTROL UNIT</td><td>ECU</td></tr> <tr><td>EXHAUST GAS RECIRCULATION</td><td>EGR</td></tr> <tr><td>EXHAUST GAS TEMPERATURE</td><td>EGT</td></tr> <tr><td>ELECTRO MAGNETIC INTERFACE</td><td>EMI</td></tr> <tr><td>END OF FRAME</td><td>EOF</td></tr> <tr><td>ELECTRIC TRAILER BRAKE</td><td>ETB</td></tr> <tr><td>FRONT AXLE</td><td>FA</td></tr> <tr><td>FRONT END</td><td>FE</td></tr> <tr><td>FRONT OF DASH</td><td>FOD</td></tr> <tr><td>FULL POWER BRAKE</td><td>FPB</td></tr> <tr><td>GLOBAL POSITIONING SYSTEM</td><td>GPS</td></tr> <tr><td>HYDRAULIC CONTROL UNIT</td><td>HCU</td></tr> <tr><td>HEAVY DUTY</td><td>HD</td></tr> <tr><td>HEAVY DUTY DIESEL</td><td>HDD</td></tr> <tr><td>HIGH PERFORMANCE TRUCK</td><td>HPT</td></tr> <tr><td>HEATING, VENTILATION, AND AIR CONDITIONING</td><td>HVAC</td></tr> </tbody> </table>				DESCRIPTION	ACRONYM	ANTILOCK BRAKING SYSTEM	ABS	ANTENNA COMMUNICATION UNIT	ACU	ALTERNATING CURRENT	AC	AXLE TO BACK OF CAB	AC	AXLE TO FRAME	AF	ACCELERATOR PEDAL MODULE	APM	ACCELERATOR POSITION SENSOR	APS	AUXILIARY POWER UNIT	APU	AUTOMATIC TRACTION CONTROL	ATC	AUDIO VIDEO INTERFACE	AVI	BRAKE HORSEPOWER	BHP	BACK OF CAB	BOC	CITIZEN BAND	CB	COLD CRANKING AMPERES	CCA	CLEAN POWER ELECTRICAL CONNECTOR	CEC	CAB OVER ENGINE	COE	DIRECT CURRENT	DC	DRIVER CONTROL MODULE	DCM	DIGITAL DATA LINK	DDL	DIESEL OXIDATION CATALYST INLET TEMPERATURE	DOCT	DIESEL PARTICULATE FILTER	DPF	DIESEL TURBOCHARGED	DT	DAY TIME RUNNING LIGHTS	DTRL	ELECTRONIC CONTROL MODULE	ECM	ELECTRONIC CONTROL UNIT	ECU	EXHAUST GAS RECIRCULATION	EGR	EXHAUST GAS TEMPERATURE	EGT	ELECTRO MAGNETIC INTERFACE	EMI	END OF FRAME	EOF	ELECTRIC TRAILER BRAKE	ETB	FRONT AXLE	FA	FRONT END	FE	FRONT OF DASH	FOD	FULL POWER BRAKE	FPB	GLOBAL POSITIONING SYSTEM	GPS	HYDRAULIC CONTROL UNIT	HCU	HEAVY DUTY	HD	HEAVY DUTY DIESEL	HDD	HIGH PERFORMANCE TRUCK	HPT	HEATING, VENTILATION, AND AIR CONDITIONING	HVAC	<table border="1" style="width: 100%; border-collapse: collapse;"> <thead> <tr> <th style="width: 80%;">DESCRIPTION</th> <th style="width: 20%;">ACRONYM</th> </tr> </thead> <tbody> <tr><td>INJECTOR DRIVE MODULE</td><td>IDM</td></tr> <tr><td>INPUT/OUTPUT</td><td>I/O</td></tr> <tr><td>INTEGRATED MOBILE COMMUNICATIONS TERMINAL</td><td>IMCT</td></tr> <tr><td>INSTRUMENT PANEL</td><td>I/P</td></tr> <tr><td>INDEPENDENT POWER TAKE-OFF</td><td>IPTO</td></tr> <tr><td>LIGHT COMMERCIAL TRANSMISSION</td><td>LCT</td></tr> <tr><td>MEDIUM DUTY</td><td>MD</td></tr> <tr><td>MALFUNCTION INDICATION LAMP</td><td>MIL</td></tr> <tr><td>MULTIPLEX SWITCH MODULE</td><td>MSM</td></tr> <tr><td>PYROMETER AMMETER MODULE</td><td>PAM</td></tr> <tr><td>PROGRAMMABLE LOGIC CONTROLLER</td><td>PLC</td></tr> <tr><td>POWER TAKE-OFF</td><td>PTO</td></tr> <tr><td>PULSE WIDTH MODULATION</td><td>PWM</td></tr> <tr><td>REAR AXLE</td><td>RA</td></tr> <tr><td>RADIO FREQUENCY</td><td>RF</td></tr> <tr><td>ROLL STABILITY PROGRAMM</td><td>RSP</td></tr> <tr><td>SEVERE SERVICE</td><td>SS</td></tr> <tr><td>TRANSMISSION CONTROL MODULE</td><td>TCM</td></tr> <tr><td>TERRESTRIAL COMMUNICATION UNIT</td><td>TCU</td></tr> <tr><td>TERRESTRIAL MOBILE COMMUNICATIONS TERMINAL</td><td>TMCT</td></tr> <tr><td>THERMAL OVERCRANK PROTECTION</td><td>TOCP</td></tr> <tr><td>THROTTLE POSITION SENSOR</td><td>TPS</td></tr> <tr><td>VEHICLE INTERFACE MODULE</td><td>VIM</td></tr> <tr><td>ZERO VOLT REFERENCE</td><td>ZVR</td></tr> </tbody> </table>				DESCRIPTION	ACRONYM	INJECTOR DRIVE MODULE	IDM	INPUT/OUTPUT	I/O	INTEGRATED MOBILE COMMUNICATIONS TERMINAL	IMCT	INSTRUMENT PANEL	I/P	INDEPENDENT POWER TAKE-OFF	IPTO	LIGHT COMMERCIAL TRANSMISSION	LCT	MEDIUM DUTY	MD	MALFUNCTION INDICATION LAMP	MIL	MULTIPLEX SWITCH MODULE	MSM	PYROMETER AMMETER MODULE	PAM	PROGRAMMABLE LOGIC CONTROLLER	PLC	POWER TAKE-OFF	PTO	PULSE WIDTH MODULATION	PWM	REAR AXLE	RA	RADIO FREQUENCY	RF	ROLL STABILITY PROGRAMM	RSP	SEVERE SERVICE	SS	TRANSMISSION CONTROL MODULE	TCM	TERRESTRIAL COMMUNICATION UNIT	TCU	TERRESTRIAL MOBILE COMMUNICATIONS TERMINAL	TMCT	THERMAL OVERCRANK PROTECTION	TOCP	THROTTLE POSITION SENSOR	TPS	VEHICLE INTERFACE MODULE	VIM	ZERO VOLT REFERENCE	ZVR
DESCRIPTION	ACRONYM																																																																																																																																										
ANTILOCK BRAKING SYSTEM	ABS																																																																																																																																										
ANTENNA COMMUNICATION UNIT	ACU																																																																																																																																										
ALTERNATING CURRENT	AC																																																																																																																																										
AXLE TO BACK OF CAB	AC																																																																																																																																										
AXLE TO FRAME	AF																																																																																																																																										
ACCELERATOR PEDAL MODULE	APM																																																																																																																																										
ACCELERATOR POSITION SENSOR	APS																																																																																																																																										
AUXILIARY POWER UNIT	APU																																																																																																																																										
AUTOMATIC TRACTION CONTROL	ATC																																																																																																																																										
AUDIO VIDEO INTERFACE	AVI																																																																																																																																										
BRAKE HORSEPOWER	BHP																																																																																																																																										
BACK OF CAB	BOC																																																																																																																																										
CITIZEN BAND	CB																																																																																																																																										
COLD CRANKING AMPERES	CCA																																																																																																																																										
CLEAN POWER ELECTRICAL CONNECTOR	CEC																																																																																																																																										
CAB OVER ENGINE	COE																																																																																																																																										
DIRECT CURRENT	DC																																																																																																																																										
DRIVER CONTROL MODULE	DCM																																																																																																																																										
DIGITAL DATA LINK	DDL																																																																																																																																										
DIESEL OXIDATION CATALYST INLET TEMPERATURE	DOCT																																																																																																																																										
DIESEL PARTICULATE FILTER	DPF																																																																																																																																										
DIESEL TURBOCHARGED	DT																																																																																																																																										
DAY TIME RUNNING LIGHTS	DTRL																																																																																																																																										
ELECTRONIC CONTROL MODULE	ECM																																																																																																																																										
ELECTRONIC CONTROL UNIT	ECU																																																																																																																																										
EXHAUST GAS RECIRCULATION	EGR																																																																																																																																										
EXHAUST GAS TEMPERATURE	EGT																																																																																																																																										
ELECTRO MAGNETIC INTERFACE	EMI																																																																																																																																										
END OF FRAME	EOF																																																																																																																																										
ELECTRIC TRAILER BRAKE	ETB																																																																																																																																										
FRONT AXLE	FA																																																																																																																																										
FRONT END	FE																																																																																																																																										
FRONT OF DASH	FOD																																																																																																																																										
FULL POWER BRAKE	FPB																																																																																																																																										
GLOBAL POSITIONING SYSTEM	GPS																																																																																																																																										
HYDRAULIC CONTROL UNIT	HCU																																																																																																																																										
HEAVY DUTY	HD																																																																																																																																										
HEAVY DUTY DIESEL	HDD																																																																																																																																										
HIGH PERFORMANCE TRUCK	HPT																																																																																																																																										
HEATING, VENTILATION, AND AIR CONDITIONING	HVAC																																																																																																																																										
DESCRIPTION	ACRONYM																																																																																																																																										
INJECTOR DRIVE MODULE	IDM																																																																																																																																										
INPUT/OUTPUT	I/O																																																																																																																																										
INTEGRATED MOBILE COMMUNICATIONS TERMINAL	IMCT																																																																																																																																										
INSTRUMENT PANEL	I/P																																																																																																																																										
INDEPENDENT POWER TAKE-OFF	IPTO																																																																																																																																										
LIGHT COMMERCIAL TRANSMISSION	LCT																																																																																																																																										
MEDIUM DUTY	MD																																																																																																																																										
MALFUNCTION INDICATION LAMP	MIL																																																																																																																																										
MULTIPLEX SWITCH MODULE	MSM																																																																																																																																										
PYROMETER AMMETER MODULE	PAM																																																																																																																																										
PROGRAMMABLE LOGIC CONTROLLER	PLC																																																																																																																																										
POWER TAKE-OFF	PTO																																																																																																																																										
PULSE WIDTH MODULATION	PWM																																																																																																																																										
REAR AXLE	RA																																																																																																																																										
RADIO FREQUENCY	RF																																																																																																																																										
ROLL STABILITY PROGRAMM	RSP																																																																																																																																										
SEVERE SERVICE	SS																																																																																																																																										
TRANSMISSION CONTROL MODULE	TCM																																																																																																																																										
TERRESTRIAL COMMUNICATION UNIT	TCU																																																																																																																																										
TERRESTRIAL MOBILE COMMUNICATIONS TERMINAL	TMCT																																																																																																																																										
THERMAL OVERCRANK PROTECTION	TOCP																																																																																																																																										
THROTTLE POSITION SENSOR	TPS																																																																																																																																										
VEHICLE INTERFACE MODULE	VIM																																																																																																																																										
ZERO VOLT REFERENCE	ZVR																																																																																																																																										
CHK	DATE	CHANGE	REV	REFERENCE	DRAWN	NAME																																																																																																																																					
DLV1	11JAN11	INITIAL RELEASE.	A	61879Y	300011	CIRCUIT DIAGRAM, PAYSTAR																																																																																																																																					
					RELEASE NO.	DATE	PART NO.																																																																																																																																				
					61879Y	12MAY09	AE08058081																																																																																																																																				
							SHEET 002																																																																																																																																				

Figure 2 Acronyms

2.3. CIRCUIT DIAGRAM INSTRUCTIONS, P. 3

**NAVISTAR, INC**

THIS PRINT IS PROVIDED ON A RESTRICTED BASIS AND IS NOT TO BE USED IN ANY WAY DETRIMENTAL TO THE INTEREST OF NAVISTAR, INC.

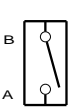
**ELECTRICAL CIRCUIT DIAGRAM**

**CHAPTER 2**

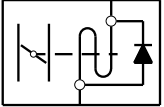
**CIRCUIT DIAGRAM INSTRUCTIONS**

---

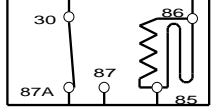
**A - SWITCH AND RELAY POSITIONS AS SHOWN ON CIRCUIT DIAGRAMS INDICATE NORMAL POSITION WITH IGNITION OFF UNLESS OTHERWISE NOTED.**



SWITCH, MECHANICAL



SOLENOID



RELAY - SUPPRESSED

**B - MULTIPLE CONNECTIONS ARE DISPLAYED ON SCHEMATIC AS SHOWN WITH R/D NUMBER & CAVITY NUMBER. REFER TO CONNECTOR COMPOSITE FOR MORE INFORMATION**

R/D NUMBER

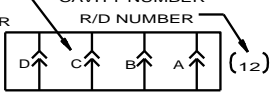
CAVITY NUMBER

(12-A)

AND/OR

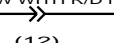
CAVITY NUMBER

R/D NUMBER



(12)

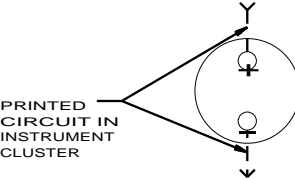
SINGLE IN-LINE CONNECTORS DISPLAYED AS SHOWN BELOW WITH R/D NUMBER




(12)

---

**C - PHANTOM LINES INDICATE PRINTED CIRCUITS OR BUSSED CIRCUITS. THESE CIRCUITS EXIST IN THE INSTRUMENT CLUSTER AND FUSE / CIRCUIT BREAKER CONNECTORS.**

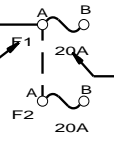


PRINTED CIRCUIT IN INSTRUMENT CLUSTER



VOLTMETER

**LOCATION / CIRCUIT NUMBER**  
**WIRE GAUGE / WIRE COLOR**



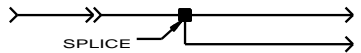
**LOCATION IN FUSE / CIRCUIT BREAKER CONNECTION**

**FUSE RATING**

20A

---

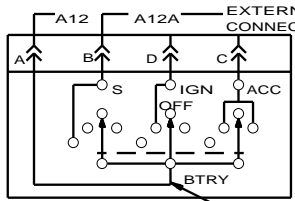
**D - MULTIPLE CIRCUIT NUMBERS ON A LINE INDICATE ONE CIRCUIT DISTRIBUTING CURRENT TO TWO CIRCUITS.**



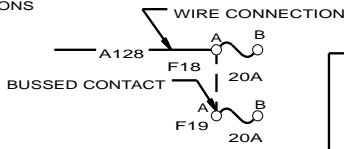
SPLICE

---

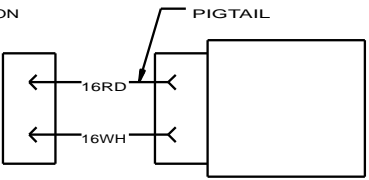
**E - SWITCHES, RELAYS AND COMPONENTS INDICATE EXTERNAL WIRE CONNECTIONS AND / OR INTERNAL CONNECTIONS.**



KEY SWITCH (1101M)



WIRE CONNECTION



PIGTAIL

BODY CONTROLLER (1602)

**EXTERNAL WIRE CONNECTIONS**

**INTERNAL CONNECTION**

**BUSED CONTACT**

---

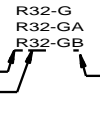
**F - CIRCUIT "11" DENOTES ANY COMMON GROUND (MORE THAN ONE CIRCUIT). ANY INDIVIDUAL GROUND CIRCUIT IS IDENTIFIED WITH THAT PARTICULAR CIRCUIT NUMBER. (E.G. CIRCUIT 32 CRUISE CONTROL IS IDENTIFIED AS PER EXAMPLE)**

11-G  
11-GA  
11-GB

COMMON GROUND CIRCUIT NUMBER

SUFFIX BEGINNING WITH G INDICATES A GROUND CIRCUIT

**INDIVIDUAL GROUND CIRCUIT NUMBER**



**SUFFIX BEGINNING WITH G INDICATES A GROUND CIRCUIT**

NOTE: FOR CIRCUIT DESCRIPTION OTHER THAN GROUNDS NEITHER THE LETTER "G" NOR THE COLOR WHITE SHALL BE USED

CHK	DATE	CHANGE	REV	REFERENCE	DRAWN	NAME
					300011	CIRCUIT DIAGRAM, PAYSTAR
0486	29DEC11	REVISED SECTION B.	B	80616P	RELEASE NO.	DATE
					61879Y	12MAY09
					PART NO.	SHEET
					AE08058081	003

Figure 3 Circuit Diagram Instructions

2.4. CIRCUIT NUMBER IDENTIFICATION AND COLOR, P. 4

NAVISTAR, INC		ELECTRICAL CIRCUIT DIAGRAM CHAPTER 2	
THIS PRINT IS PROVIDED ON A RESTRICTED BASIS AND IS NOT TO BE USED IN ANY WAY DETRIMENTAL TO THE INTEREST OF NAVISTAR, INC.		CIRCUIT NUMBER IDENTIFICATION AND COLOR	
CIRCUIT NUMBER	COLOR	DESCRIPTION	
1	LTBL	ALTERNATOR - FIELD	
2	RD	ALTERNATOR - CHARGE	
3	DKBL	SERIAL / DATA COMMUNICATION J1587 / J1708 (+)	
	GY	SERIAL / DATA COMMUNICATION J1587 / J1708 (-)	
4	DKBL	SERIAL / DATA COMMUNICATION J1922 (+)	
	GY	SERIAL / DATA COMMUNICATION J1922 (-)	
5	YL	SERIAL / DATA COMMUNICATION J1939/11 / J1939/15 (+)	
	GN	SERIAL / DATA COMMUNICATION J1939/11 / J1939/15 (-)	
6	GY	LOW VOLTAGE ELECTRONIC FEED (LESS THAN 9 VOLTS)	
7	RD	ALTERNATOR - RESISTANCE	
8			
9	GY	LOW VOLTAGE ELECTRONIC GROUND	
10	WH	CHASSIS / ENGINE GROUND	
11	WH	CAB / SLEEPER GROUND	
12	LTBL	ACCESSORY FEED	
13	PK	IGNITION FEED	
	BK	IGNITION FEED (BODY BUILDER CONNECTOR)	
14	RD	BATTERY FEED	
15	RD	KEY SWITCH FEED	
16			
17	PK	STARTER CONTROL	
18	PK	GLOW PLUG / PREHEATER	
19	GY	ENGINE SHUTDOWN	
20	LTGN	REMOTE POWER MODULE	
21	TN	COLD START CONTROLS (ETHER)	
22	TN	TIRE PRESSURE MONITORING / CONTROL	
23	TN	ENGINE FAN / SHUTTERS	
24	GY	ENGINE EXHAUST BRAKE	
25	TN	PYROMETER	
26	TN	AMMETER	
27	TN	VOLTMETER	
28	TN	INSTRUMENTS AND GAUGES	
29	TN	ENGINE WATER TEMPERATURE	
30	TN	ENGINE OIL TEMPERATURE	
31	TN	TRANSMISSION OIL TEMPERATURE	
32	TN	AXLE OIL TEMPERATURE	
33	TN	ENGINE OIL LEVEL	
34	TN	COOLANT LEVEL	
35	TN	ENGINE OIL PRESSURE	
36	TN	FUEL LEVEL	
37	TN	FUEL PUMP	
38	GY	LIFT AXLE	
39	GY	AIR DRYER HEATER	
40	GY	LOW AIR PRESSURE WARNING	

CHK	DATE	CHANGE	REV	REFERENCE	DRAWN	NAME
DLV1	11JAN11	INITIAL RELEASE.	A	61879Y	300011	CIRCUIT DIAGRAM, PAYSTAR
					RELEASE NO.	DATE
					61879Y	12MAY09
					PART NO.	SHEET
					AE08058081	004

Figure 4 Circuit Number Identification and Color

2.5. CIRCUIT NUMBER IDENTIFICATION AND COLOR (CONT.), P. 5

<b>NAVISTAR, INC</b>				<b>ELECTRICAL CIRCUIT DIAGRAM 2</b>			
THIS PRINT IS PROVIDED ON A RESTRICTED BASIS AND IS NOT TO BE USED IN ANY WAY DETRIMENTAL TO THE INTEREST OF NAVISTAR, INC.				<b>CHAPTER 2</b>			
				CIRCUIT NUMBER IDENTIFICATION AND COLOR (CONT)			
CIRCUIT NUMBER	COLOR	DESCRIPTION					
41	TN	AIR TEMPERATURE					
42	GY	FRONT AXLE ENGAGED					
43	GY	POWER DIVIDER LOCK (PDL) WARNING					
44	GY	PARK BRAKE WARNING					
45	LTGN	ANTITHEFT WARNING					
46	GY	POWER TAKEOFF WARNING					
47	GY	SPEEDOMETER					
48	GY	TACHOMETER					
49	GY	DIFFERENTIAL LOCK WARNING					
50	YL	LIGHT SWITCH FEED					
51	YL	DIMMER SWITCH FEED					
52	YL	HEADLIGHT HI - BEAM					
53	YL	HEADLIGHT LO - BEAM					
54	BN	PARKING / MARKER LIGHTS					
55	OR	TURN SIGNAL - FEED					
56	OR	TURN SIGNAL LIGHTS - LEFT					
	YL	TURN SIGNAL LIGHTS - LEFT (BODY BUILDER CONNECTION)					
57	OR	TURN SIGNAL LIGHTS - RIGHT					
	LTGN	TURN SIGNAL LIGHTS - RIGHT (BODY BUILDER CONNECTION)					
58	BN	CLEARANCE / IDENTIFICATION LIGHTS					
59	GY	SOLENOID					
60	OR	HAZARD LIGHTS					
61	GY	AIR SUSPENSION					
62	DKBL	PANEL LIGHTS					
63	DKBL	COURTESY / DOME LIGHTS					
64	YL	FOG / DRIVING LIGHTS					
65	OR	CAB REAR FLOOD LIGHTS					
66	YL	DAYTIME RUNNING LIGHT					
67	GY	OBSTACLE AVOIDANCE / REMOTE SENSOR					
68	BN	TAIL LIGHTS					
69	BN	LICENSE PLATE LIGHT					
	OR	STOP LIGHTS					
70	RD	STOP LIGHTS (BODY BUILDER CONNECTION)					
	OR	BACKUP - LIGHTS					
71	LTBL	BACKUP - LIGHTS (BODY BUILDER CONNECTION)					
	OR	TRAILER AUXILIARY FEED - BATTERY					
72	OR	TRAILER AUXILIARY FEED - BATTERY					
73	LTGN	PWM					
74	LTGN	HEATER RECIRC MOTOR					
75	LTGN	HEATER BLOWER MOTOR					
76	LTGN	AUXILIARY FAN					
77	LTGN	AIR CONDITIONER					
78	LTGN	MIRRORS - HEATED, MOTORIZED					
79	GY	SEAT BELTS					
80	BK	SLEEPER BOX RELAY - FEED					

CHK	DATE	CHANGE	REV	REFERENCE	DRAWN	NAME
DLV1	11JAN11	INITIAL RELEASE.	A	61879Y	300011	CIRCUIT DIAGRAM, PAYSTAR
					RELEASE NO.	DATE
					61879Y	12MAY09
					PART NO.	SHEET
					AE08058081	005

Figure 5 Circuit Number Identification and Color (Cont.)

2.6. CIRCUIT NUMBER IDENTIFICATION AND COLOR (CONT.), P. 6

<b>NAVISTAR, INC</b>				<b>ELECTRICAL CIRCUIT DIAGRAM</b>																																																																																																																																														
THIS PRINT IS PROVIDED ON A RESTRICTED BASIS AND IS NOT TO BE USED IN ANY WAY DETRIMENTAL TO THE INTEREST OF NAVISTAR, INC.				<b>CHAPTER 2</b>																																																																																																																																														
				<b>CIRCUIT NUMBER IDENTIFICATION AND COLOR (CONT)</b>																																																																																																																																														
<table border="1" style="width: 100%; border-collapse: collapse; margin-top: 10px;"> <thead> <tr> <th style="width: 15%;">CIRCUIT NUMBER</th> <th style="width: 15%;">COLOR</th> <th style="width: 70%;">DESCRIPTION</th> </tr> </thead> <tbody> <tr><td>81</td><td>LTGN</td><td>POWER DOOR LOCKS</td></tr> <tr><td>82</td><td>GY</td><td>WINDSHIELD WIPER</td></tr> <tr><td>83</td><td>LTGN</td><td>POWER WINDOWS</td></tr> <tr><td>84</td><td>LTGN</td><td>CIGAR LIGHTER</td></tr> <tr><td>85</td><td>GY</td><td>HORN</td></tr> <tr><td>86</td><td>LTGN</td><td>RADIO - ENTERTAINMENT / CLOCK</td></tr> <tr><td>87</td><td>GY</td><td>WINDSHIELD WASHER</td></tr> <tr><td>88</td><td>LTGN</td><td>CLOCK / HOURMETER</td></tr> <tr><td>89</td><td>VT</td><td>AIR BAG</td></tr> <tr><td>90</td><td>GY</td><td>HYDRAULIC BRAKE PUMP</td></tr> <tr><td>91</td><td>VT</td><td>INTERCOMMUNICATION</td></tr> <tr><td>92</td><td>TN</td><td>TRANSMISSION CONTROLS - ELECTRONICS</td></tr> <tr><td>93</td><td>TN</td><td>AXLE SHIFT CONTROL</td></tr> <tr><td>94</td><td>GY</td><td>ANTILOCK BRAKE SYSTEM</td></tr> <tr><td>95</td><td>TN</td><td>EXHAUST EMISSION</td></tr> <tr><td>96</td><td>YL</td><td>SNOW PLOW LIGHTS / CRUISE CONTROLS</td></tr> <tr><td>97</td><td>VT</td><td>ENGINE CONTROLS - ELECTRONIC</td></tr> <tr><td>98</td><td>BK</td><td>DATALINK AND DIAGNOSTICS</td></tr> <tr><td>99</td><td>VT</td><td>ACCELERATOR POSITION SENSOR (APS)</td></tr> <tr><td>100</td><td>GY</td><td>AIR HORN (ELECTRIC SOLENOID ACTUATED)</td></tr> <tr><td>101</td><td>TN</td><td>BRAKE APPLICATION AIR</td></tr> <tr><td>102</td><td>YL</td><td>FLASH TO PASS</td></tr> <tr><td>103</td><td>LTGN</td><td>BODY BUILDER AUXILIARY FEED</td></tr> <tr><td>104</td><td>DKBL</td><td>REMOTE START / STOP</td></tr> <tr><td>105</td><td>LTGN</td><td>HEATED SEATS</td></tr> <tr><td>106</td><td>OR</td><td>HIGH VOLTAGE ALTERNATOR AC CHARGE</td></tr> <tr><td>107</td><td>GY</td><td>INSTRUMENT CLUSTER ELECTRONIC FEED (5V)</td></tr> <tr><td>108</td><td>GY</td><td>BRAKE PAD WEAR SENSOR</td></tr> <tr><td>109</td><td>GY</td><td>BRAKE STROKE / SLACK ADJUSTER</td></tr> <tr><td>110</td><td>GY</td><td>INSTRUMENT CLUSTER ELECTRONIC GROUND</td></tr> <tr><td>111</td><td>TN</td><td>FUEL FILTER RESTRICTION TRANSDUCER</td></tr> <tr><td>112</td><td>GY</td><td>LIFT GATE</td></tr> </tbody> </table> <table border="1" style="width: 100%; border-collapse: collapse; margin-top: 10px;"> <thead> <tr> <th style="width: 10%;">PREFIX</th> <th style="width: 90%;">LOCATION</th> </tr> </thead> <tbody> <tr><td>A</td><td>CAB - INSTRUMENT PANEL MODULE</td></tr> <tr><td>B</td><td>CAB - DRIVER CONTROL MODULE</td></tr> <tr><td>C</td><td>CAB - HEADER / CLEARANCE LIGHTS</td></tr> <tr><td>D</td><td>CAB - ROOF / REAR PANEL</td></tr> <tr><td>E</td><td>CAB - LEFT DOOR / DOORS</td></tr> <tr><td>F</td><td>CAB - RIGHT DOOR / DOORS</td></tr> <tr><td>H</td><td>CAB - SLEEPER</td></tr> <tr><td>J</td><td>CAB - DASH (OUTSIDE)</td></tr> <tr><td>K</td><td>ENGINE / RADIATOR</td></tr> <tr><td>L</td><td>TRANSMISSION</td></tr> <tr><td>M</td><td>CHASSIS / FRONT END (CAB DASH PANEL FORWARD)</td></tr> <tr><td>N</td><td>CHASSIS / CENTER SECTION (CAB DASH PANEL TO CAB REAR XMBR)</td></tr> <tr><td>P</td><td>CHASSIS / WHEEL BASE SECTION</td></tr> <tr><td>R</td><td>CHASSIS / SUSPENSION / REAR AXLE / AXLES</td></tr> <tr><td>S</td><td>CHASSIS / AF SECTION / STOP / TAIL / TURN LIGHTS</td></tr> <tr><td>T</td><td>TRAVEL DOORS</td></tr> <tr><td>U</td><td>HOOD MTD HEADLIGHTS / MARKER LIGHTS</td></tr> <tr><td>V</td><td>SLEEPER ROOF / BACK PANEL WIRING</td></tr> <tr><td>W</td><td>WARDROBE CABINET WIRING</td></tr> </tbody> </table>								CIRCUIT NUMBER	COLOR	DESCRIPTION	81	LTGN	POWER DOOR LOCKS	82	GY	WINDSHIELD WIPER	83	LTGN	POWER WINDOWS	84	LTGN	CIGAR LIGHTER	85	GY	HORN	86	LTGN	RADIO - ENTERTAINMENT / CLOCK	87	GY	WINDSHIELD WASHER	88	LTGN	CLOCK / HOURMETER	89	VT	AIR BAG	90	GY	HYDRAULIC BRAKE PUMP	91	VT	INTERCOMMUNICATION	92	TN	TRANSMISSION CONTROLS - ELECTRONICS	93	TN	AXLE SHIFT CONTROL	94	GY	ANTILOCK BRAKE SYSTEM	95	TN	EXHAUST EMISSION	96	YL	SNOW PLOW LIGHTS / CRUISE CONTROLS	97	VT	ENGINE CONTROLS - ELECTRONIC	98	BK	DATALINK AND DIAGNOSTICS	99	VT	ACCELERATOR POSITION SENSOR (APS)	100	GY	AIR HORN (ELECTRIC SOLENOID ACTUATED)	101	TN	BRAKE APPLICATION AIR	102	YL	FLASH TO PASS	103	LTGN	BODY BUILDER AUXILIARY FEED	104	DKBL	REMOTE START / STOP	105	LTGN	HEATED SEATS	106	OR	HIGH VOLTAGE ALTERNATOR AC CHARGE	107	GY	INSTRUMENT CLUSTER ELECTRONIC FEED (5V)	108	GY	BRAKE PAD WEAR SENSOR	109	GY	BRAKE STROKE / SLACK ADJUSTER	110	GY	INSTRUMENT CLUSTER ELECTRONIC GROUND	111	TN	FUEL FILTER RESTRICTION TRANSDUCER	112	GY	LIFT GATE	PREFIX	LOCATION	A	CAB - INSTRUMENT PANEL MODULE	B	CAB - DRIVER CONTROL MODULE	C	CAB - HEADER / CLEARANCE LIGHTS	D	CAB - ROOF / REAR PANEL	E	CAB - LEFT DOOR / DOORS	F	CAB - RIGHT DOOR / DOORS	H	CAB - SLEEPER	J	CAB - DASH (OUTSIDE)	K	ENGINE / RADIATOR	L	TRANSMISSION	M	CHASSIS / FRONT END (CAB DASH PANEL FORWARD)	N	CHASSIS / CENTER SECTION (CAB DASH PANEL TO CAB REAR XMBR)	P	CHASSIS / WHEEL BASE SECTION	R	CHASSIS / SUSPENSION / REAR AXLE / AXLES	S	CHASSIS / AF SECTION / STOP / TAIL / TURN LIGHTS	T	TRAVEL DOORS	U	HOOD MTD HEADLIGHTS / MARKER LIGHTS	V	SLEEPER ROOF / BACK PANEL WIRING	W	WARDROBE CABINET WIRING
CIRCUIT NUMBER	COLOR	DESCRIPTION																																																																																																																																																
81	LTGN	POWER DOOR LOCKS																																																																																																																																																
82	GY	WINDSHIELD WIPER																																																																																																																																																
83	LTGN	POWER WINDOWS																																																																																																																																																
84	LTGN	CIGAR LIGHTER																																																																																																																																																
85	GY	HORN																																																																																																																																																
86	LTGN	RADIO - ENTERTAINMENT / CLOCK																																																																																																																																																
87	GY	WINDSHIELD WASHER																																																																																																																																																
88	LTGN	CLOCK / HOURMETER																																																																																																																																																
89	VT	AIR BAG																																																																																																																																																
90	GY	HYDRAULIC BRAKE PUMP																																																																																																																																																
91	VT	INTERCOMMUNICATION																																																																																																																																																
92	TN	TRANSMISSION CONTROLS - ELECTRONICS																																																																																																																																																
93	TN	AXLE SHIFT CONTROL																																																																																																																																																
94	GY	ANTILOCK BRAKE SYSTEM																																																																																																																																																
95	TN	EXHAUST EMISSION																																																																																																																																																
96	YL	SNOW PLOW LIGHTS / CRUISE CONTROLS																																																																																																																																																
97	VT	ENGINE CONTROLS - ELECTRONIC																																																																																																																																																
98	BK	DATALINK AND DIAGNOSTICS																																																																																																																																																
99	VT	ACCELERATOR POSITION SENSOR (APS)																																																																																																																																																
100	GY	AIR HORN (ELECTRIC SOLENOID ACTUATED)																																																																																																																																																
101	TN	BRAKE APPLICATION AIR																																																																																																																																																
102	YL	FLASH TO PASS																																																																																																																																																
103	LTGN	BODY BUILDER AUXILIARY FEED																																																																																																																																																
104	DKBL	REMOTE START / STOP																																																																																																																																																
105	LTGN	HEATED SEATS																																																																																																																																																
106	OR	HIGH VOLTAGE ALTERNATOR AC CHARGE																																																																																																																																																
107	GY	INSTRUMENT CLUSTER ELECTRONIC FEED (5V)																																																																																																																																																
108	GY	BRAKE PAD WEAR SENSOR																																																																																																																																																
109	GY	BRAKE STROKE / SLACK ADJUSTER																																																																																																																																																
110	GY	INSTRUMENT CLUSTER ELECTRONIC GROUND																																																																																																																																																
111	TN	FUEL FILTER RESTRICTION TRANSDUCER																																																																																																																																																
112	GY	LIFT GATE																																																																																																																																																
PREFIX	LOCATION																																																																																																																																																	
A	CAB - INSTRUMENT PANEL MODULE																																																																																																																																																	
B	CAB - DRIVER CONTROL MODULE																																																																																																																																																	
C	CAB - HEADER / CLEARANCE LIGHTS																																																																																																																																																	
D	CAB - ROOF / REAR PANEL																																																																																																																																																	
E	CAB - LEFT DOOR / DOORS																																																																																																																																																	
F	CAB - RIGHT DOOR / DOORS																																																																																																																																																	
H	CAB - SLEEPER																																																																																																																																																	
J	CAB - DASH (OUTSIDE)																																																																																																																																																	
K	ENGINE / RADIATOR																																																																																																																																																	
L	TRANSMISSION																																																																																																																																																	
M	CHASSIS / FRONT END (CAB DASH PANEL FORWARD)																																																																																																																																																	
N	CHASSIS / CENTER SECTION (CAB DASH PANEL TO CAB REAR XMBR)																																																																																																																																																	
P	CHASSIS / WHEEL BASE SECTION																																																																																																																																																	
R	CHASSIS / SUSPENSION / REAR AXLE / AXLES																																																																																																																																																	
S	CHASSIS / AF SECTION / STOP / TAIL / TURN LIGHTS																																																																																																																																																	
T	TRAVEL DOORS																																																																																																																																																	
U	HOOD MTD HEADLIGHTS / MARKER LIGHTS																																																																																																																																																	
V	SLEEPER ROOF / BACK PANEL WIRING																																																																																																																																																	
W	WARDROBE CABINET WIRING																																																																																																																																																	
CHK	DATE	CHANGE	REV	REFERENCE	DRAWN	NAME																																																																																																																																												
DLV1	11JAN11	INITIAL RELEASE.	A	61879Y	300011	CIRCUIT DIAGRAM, PAYSTAR																																																																																																																																												
					RELEASE NO.	DATE	PART NO.																																																																																																																																											
					61879Y	12MAY09	AE08058081																																																																																																																																											
							SHEET 006																																																																																																																																											

Figure 6 Circuit Number Identification and Color (Cont.)



2.7. LAMP BULB CHART, P. 7

<b>NAVISTAR, INC</b> <small>THIS PRINT IS PROVIDED ON A RESTRICTED BASIS AND IS NOT TO BE USED IN ANY WAY DETRIMENTAL TO THE INTEREST OF NAVISTAR, INC.</small>		<b>ELECTRICAL CIRCUIT DIAGRAM</b> <b>CHAPTER 2</b> <b>LAMP BULB CHART</b>	
<b>BULB APPLICATION</b>	<b>CANDLE POWER OR WATT</b>	<b>BULB TRADE NUMBER</b>	
BACK-UP LIGHT	32 CP	GE1156	
CLEARANCE & IDENTIFICATION	3 CP	GE168	
COURTESY LIGHT	21 CP	1142	
DOVE LIGHTS	21 CP	1142	
FOG LIGHT	100 WATT	4921-1	
LOW BEAMS	55 WATT	GE9007	
HIGH BEAMS	65 WATT	GE9007	
CIGAR LIGHTER	1 CP	1455	
GAUGE BACKLIGHT	2 CP	194	
GAUGE WARNING LED (RED)	2 CP	194	
COLD AMBIENT PROTECTION LED (RED)	2 CP	194	
FUEL FILTER LED (YELLOW)	2 CP	194	
WARN ENGINE LED (YELLOW)	2 CP	194	
STOP ENGINE LED (RED)	2 CP	194	
BRAKE PRESSURE LED	2 CP	194	
CHECK TRANSMISSION LED	2 CP	194	
TRAILER ABS LED	2 CP	194	
LEFT TURN SIGNAL LED (GREEN)	2 CP	194	
TRACTION CONTROL LED (GREEN)	2 CP	194	
WATER IN FUEL LED (YELLOW)	2 CP	194	
PARK FLUID LED (RED)	2 CP	194	
CHECK ELECTRICAL SYSTEM LED (YELLOW)	2 CP	194	
PARK BRAKE LED (RED)	2 CP	194	
CRUISE CONTROL ACTIVE LED (YELLOW)	2 CP	194	
ANTILOCK BRAKING SYSTEM LED (YELLOW)	2 CP	194	
RIGHT TURN LED (GREEN)	2 CP	194	
COOLANT LEVEL LED (RED)	2 CP	194	
SEAT BELT LED (RED)	2 CP	194	
HIGH BEAM ICON LED (BLUE)	2 CP	194	
CHECK AIR CONDITIONER LED (YELLOW)	2 CP	82S272109-4	
MAP LIGHT	3 CP	1816	
SIDE MARKER	-	2548	
STOP & TURN/TAIL & LICENSE PLATE	32/3 CP	3157	
TURN SIGNAL/MARKER (FENDER)	32/3 CP	3157	
TURN SIGNAL & MARKER LIGHT	-	2356	
WORK (TRAILER HOOK)	35 WATT	4411	
BACK-UP LIGHTS-UPPER AND LOWER BUNK READING LIGHT	15 CP	1003	
CABINET / WARDROBE LIGHT	5 WATT	7575	
UNDER BUNK LIGHT	21 CP / 2 (12CP)	577 / 211	
ACCENT LIGHT	2 (12CP)	211	
DOVE LIGHT	15 WATT	F15T8-CW	
SLEEPER FLOOR LIGHT	4 CP	W5W	
HEATER AND AIR CONDITIONER CONTROL	3 CP	168	
LUGGAGE COMPARTMENT LIGHT	6 CP	99	
READING LIGHT	15 CP	1003	

CHK	DATE	CHANGE	REV	REFERENCE	DRAWN	NAME
DLV1	11JAN11	INITIAL RELEASE.	A	61879Y	300011	CIRCUIT DIAGRAM, PAYSTAR
					RELEASE NO.	DATE
					61879Y	12MAY09
					PART NO.	SHEET
					AE08058081	007

Figure 7 Lamp Bulb Chart

2.8. RELAY FUNCTION AND WIRING GUIDE, P. 8

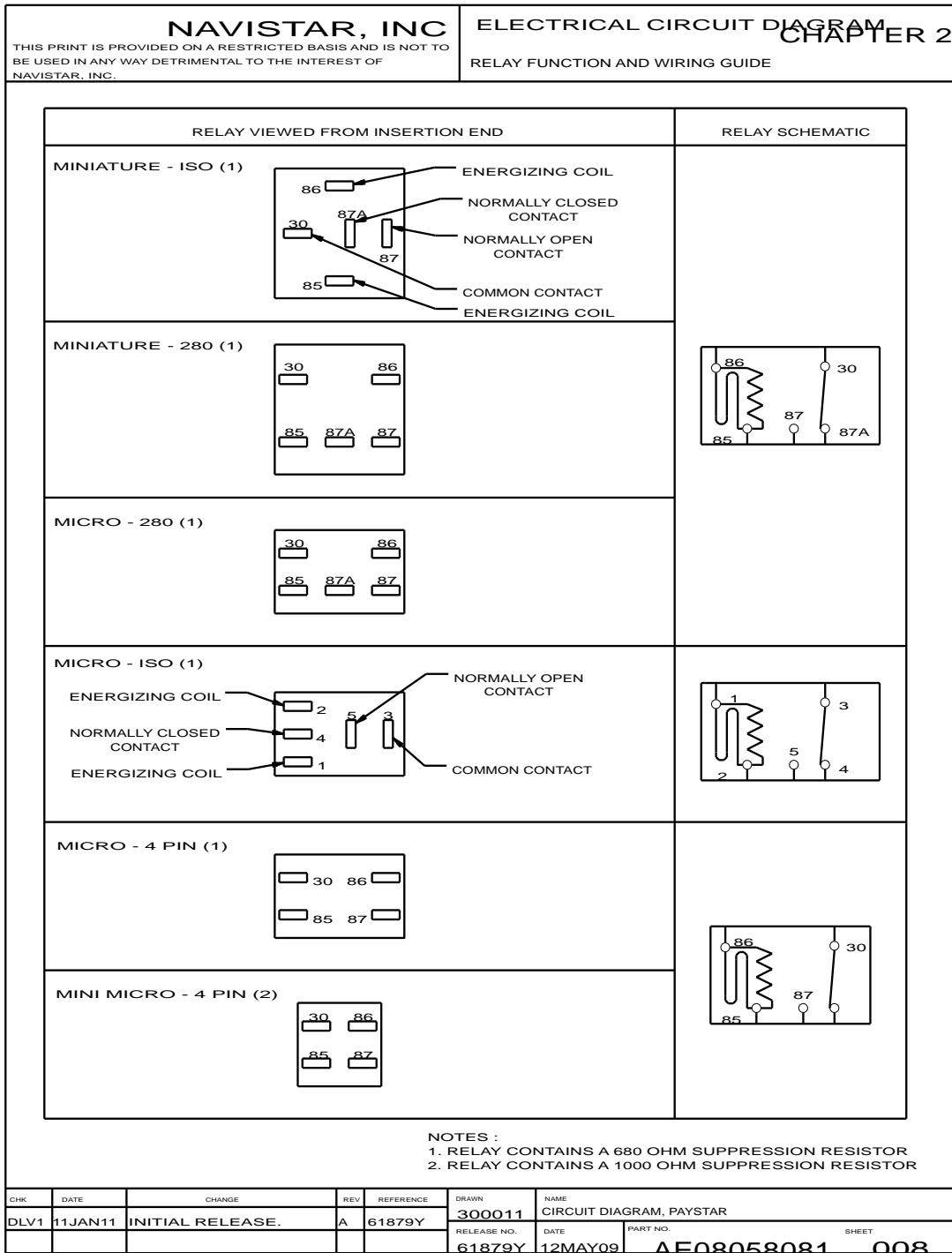


Figure 8 Relay Function and Wiring Guide

2.9. SCHEMATIC SYMBOL CHART, P. 9

<b>NAVISTAR, INC</b> <small>THIS PRINT IS PROVIDED ON A RESTRICTED BASIS AND IS NOT TO BE USED IN ANY WAY DETRIMENTAL TO THE INTEREST OF NAVISTAR, INC.</small>				<b>ELECTRICAL CIRCUIT DIAGRAM</b> <b>CHAPTER 2</b> SCHEMATIC SYMBOL CHART			
		AIR DRYER				CIGAR LIGHTER	
		ALARM		TYPE 1    TYPE 2 OR 3 		CIRCUIT BREAKER	
		ALTERNATOR				DIODE	
		AMMETER				DIODE, LIGHT EMITTING	
		BATTERY				FAN SOLENOID	
		BLUNT CUT CIRCUIT				FEMALE TERMINAL	
		BUSBAR				FUSE	
CHK	DATE	CHANGE	REV	REFERENCE	DRAWN	NAME	
DLV1	11JAN11	INITIAL RELEASE.	A	61879Y	300011	CIRCUIT DIAGRAM, PAYSTAR	
					RELEASE NO.	DATE	PART NO. SHEET
					61879Y	12MAY09	AE08058081 009

Figure 9 Schematic Symbol Chart

2.10. SCHEMATIC SYMBOL CHART (CONT.), P. 10

NAVISTAR, INC					ELECTRICAL CIRCUIT DIAGRAM				
THIS PRINT IS PROVIDED ON A RESTRICTED BASIS AND IS NOT TO BE USED IN ANY WAY DETRIMENTAL TO THE INTEREST OF NAVISTAR, INC.					CHAPTER 2 SCHEMATIC SYMBOL CHART (CONT)				
SYMBOL		DESCRIPTION			SYMBOL		DESCRIPTION		
		FUSES W/ BUSBAR					HORN		
		FUSIBLE LINK					KEY SWITCH		
		GROUND N/ STUD					KEY SWITCH, COMPLEX		
		GROUND W/ STUD					LIGHT W/ SWITCH		
		HEATER					LIGHT, DOUBLE FILAMENT		
		HOLDER, FUSE W/ BUSBAR					LIGHT, SINGLE FILAMENT		
CHK	DATE	CHANGE	REV	REFERENCE	DRAWN	NAME			
DLV1	11JAN11	INITIAL RELEASE.	A	61879Y	300011	CIRCUIT DIAGRAM, PAYSTAR			
					RELEASE NO.	DATE	PART NO.	SHEET	
					61879Y	12MAY09	AE08058081	010	

Figure 10 Schematic Symbol Chart (Cont.)

2.11. SCHEMATIC SYMBOL CHART (CONT.), P. 11

<b>NAVISTAR, INC</b> <small>THIS PRINT IS PROVIDED ON A RESTRICTED BASIS AND IS NOT TO BE USED IN ANY WAY DETRIMENTAL TO THE INTEREST OF NAVISTAR, INC.</small>				<b>ELECTRICAL CIRCUIT DIAGRAM</b> <b>CHAPTER 2</b> <b>SCHEMATIC SYMBOL CHART (CONT)</b>			
SYMBOL		DESCRIPTION		SYMBOL		DESCRIPTION	
		MALE TERMINAL				RESISTOR	
		MOTOR				SENDER - FUEL, OIL, TEMP, WATER	
		PASS THRU CONNECTION				SENSOR, PRESSURE. ABS 6	
		PRESSURE SWITCH				SENSOR, MAGNETIC	
		RELAY, FIVE TERMINAL				SENSOR, YAW	
		RELAY, FOUR TERMINAL				SOLENOID	
		RELAY, LATCHING				SOLENOID W/ DIODE	
CHK	DATE	CHANGE	REV	REFERENCE	DRAWN	NAME	
DLV1	11JAN11	INITIAL RELEASE.	A	61879Y	300011	CIRCUIT DIAGRAM, PAYSTAR	
					RELEASE NO.	DATE	PART NO. SHEET
					61879Y	12MAY09	AE08058081 011

Figure 11 Schematic Symbol Chart (Cont.)

2.12. SCHEMATIC SYMBOL CHART (CONT.), P. 12

NAVISTAR, INC					ELECTRICAL CIRCUIT DIAGRAM				
THIS PRINT IS PROVIDED ON A RESTRICTED BASIS AND IS NOT TO BE USED IN ANY WAY DETRIMENTAL TO THE INTEREST OF NAVISTAR, INC.					CHAPTER 2				
					SCHEMATIC SYMBOL CHART (CONT)				
SYMBOL		DESCRIPTION			SYMBOL		DESCRIPTION		
		SPEAKER					SWITCH, PUSH BUTTON		
		SPLICE					TERMINATING RESISTOR		
		STUD					THERMOSTAT		
		START MOTOR W/ TOCP					VALVE, ETHER BOTTLE		
		SWITCH, MECHANICAL (NORMALLY OPEN)					VALVE, MODULATOR		
		SWITCH, MECHANICAL (NORMALLY CLOSED)					THERMISTOR		
CHK	DATE	CHANGE	REV	REFERENCE	DRAWN	NAME			
DLV1	11JAN11	INITIAL RELEASE.	A	61879Y	300011	CIRCUIT DIAGRAM, PAYSTAR			
					RELEASE NO.	DATE	PART NO.	SHEET	
					61879Y	12MAY09	AE08058081	012	

Figure 12 Schematic Symbol Chart (Cont.)

# 12 VOLT POWER DISTRIBUTION (CHAPTER 3)

## 3.1. BATTERY FEED WITH ENGINE BRAKE, P. 1

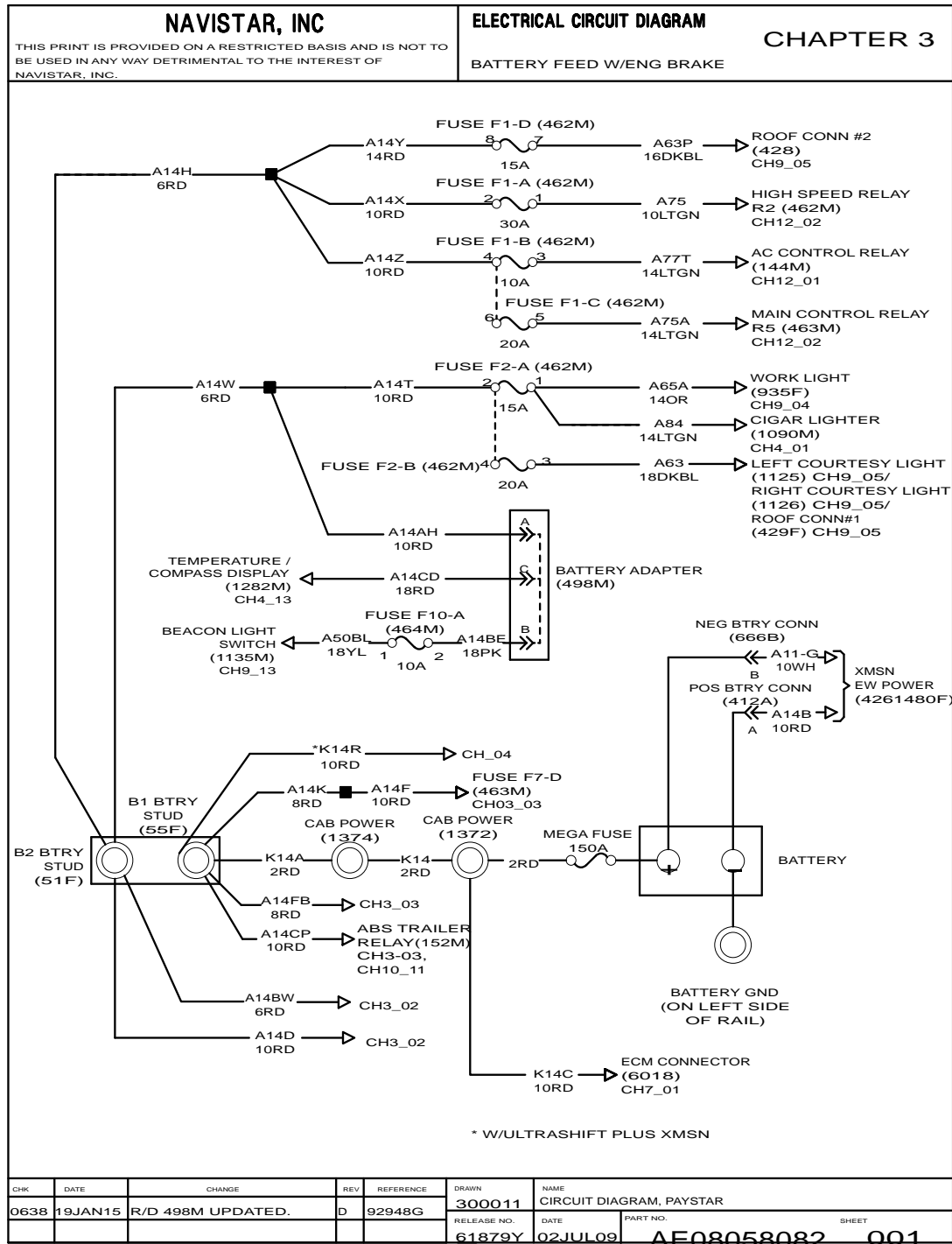


Figure 13 Battery Feed with Engine Brake

3.2. BATTERY FEED WITH ENGINE BRAKE WITH 500K BAUD RATE, P. 1A

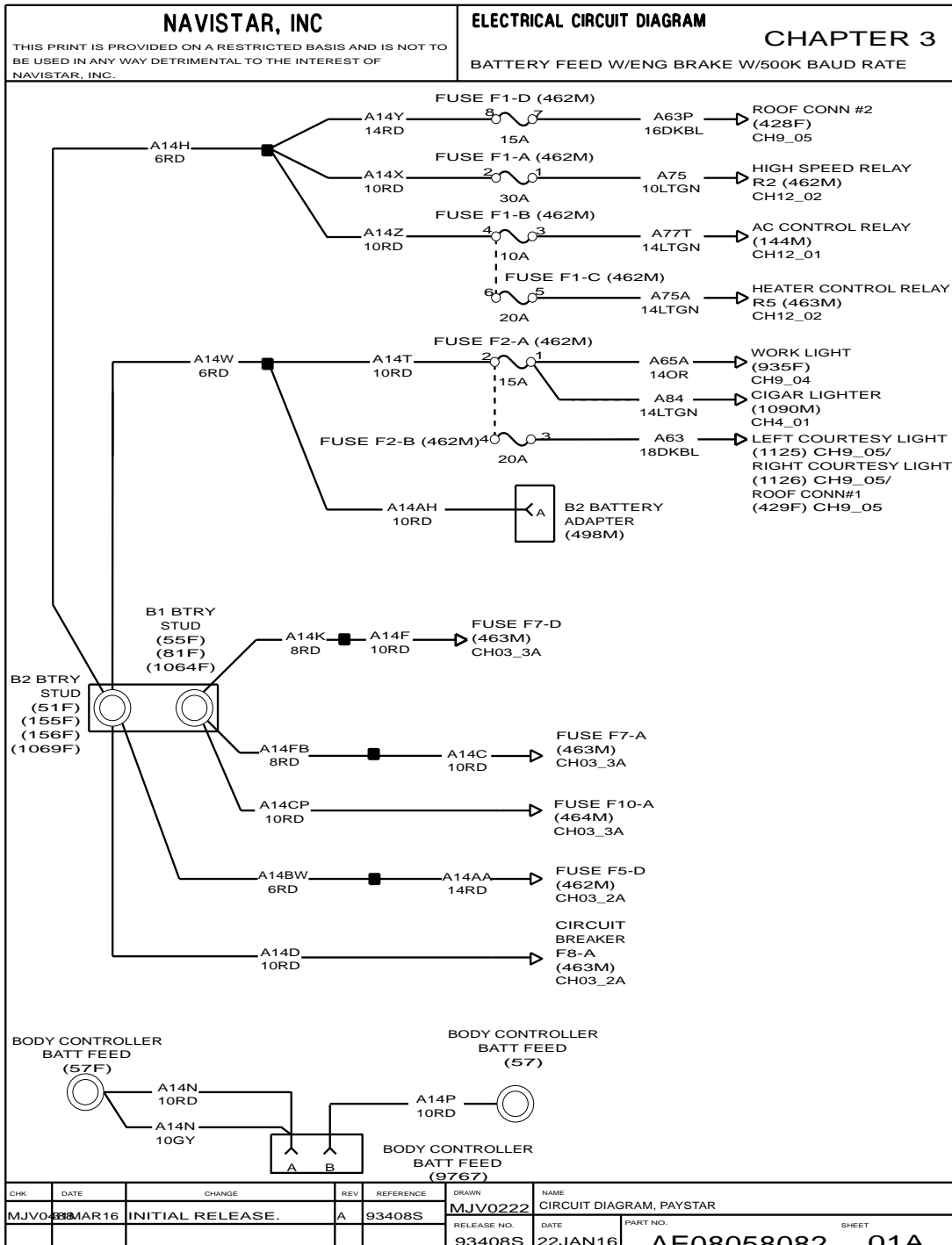


Figure 14 Battery Feed with Engine Brake with 500K Baud Rate



3.3. BATTERY FEED WITH ENGINE BRAKE (CONT.), P. 2

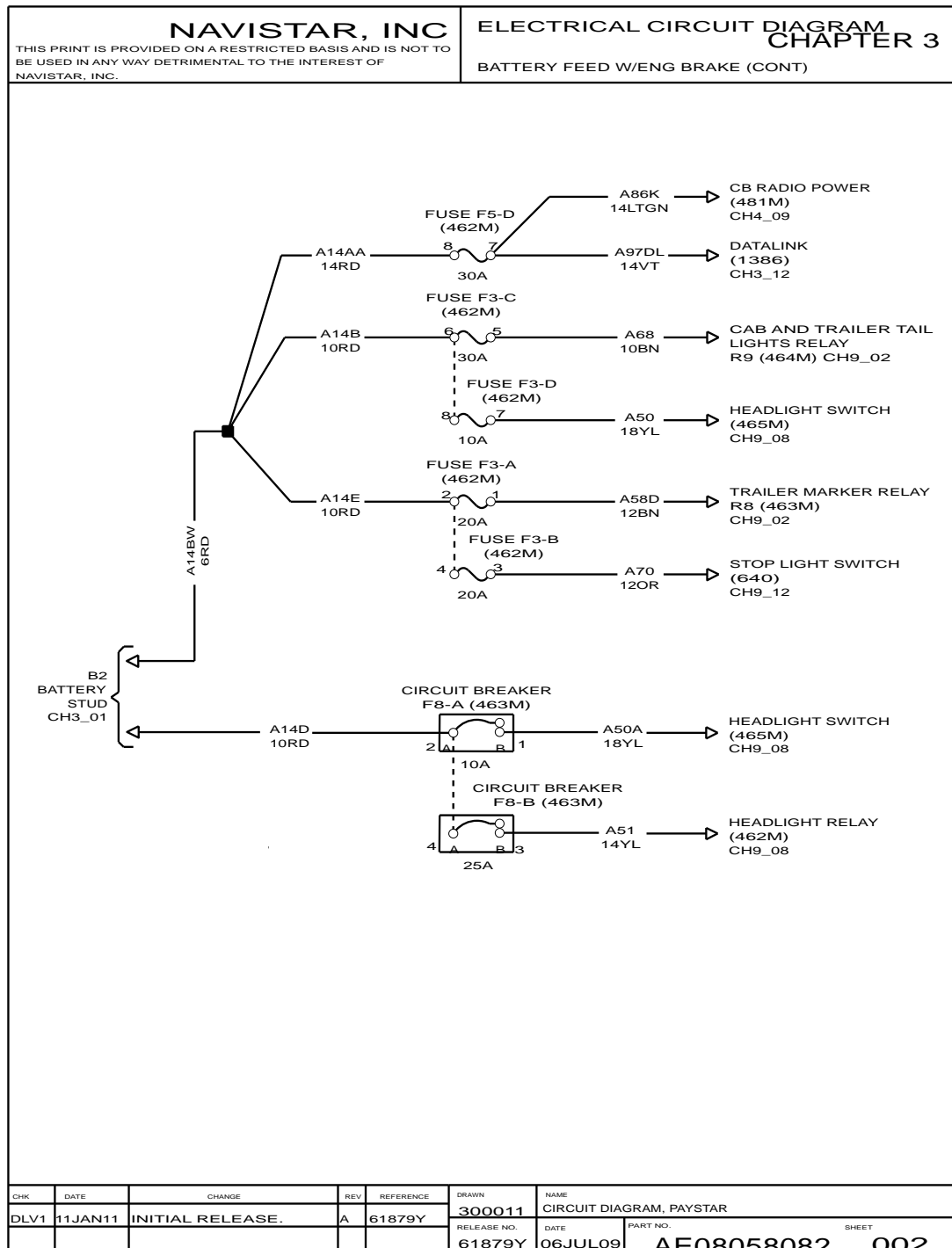


Figure 15 Battery Feed with Engine Brake (Cont.)

3.4. BATTERY FEED WITH ENGINE BRAKE WITH 500K BAUD RATE (CONT.), P. 2A

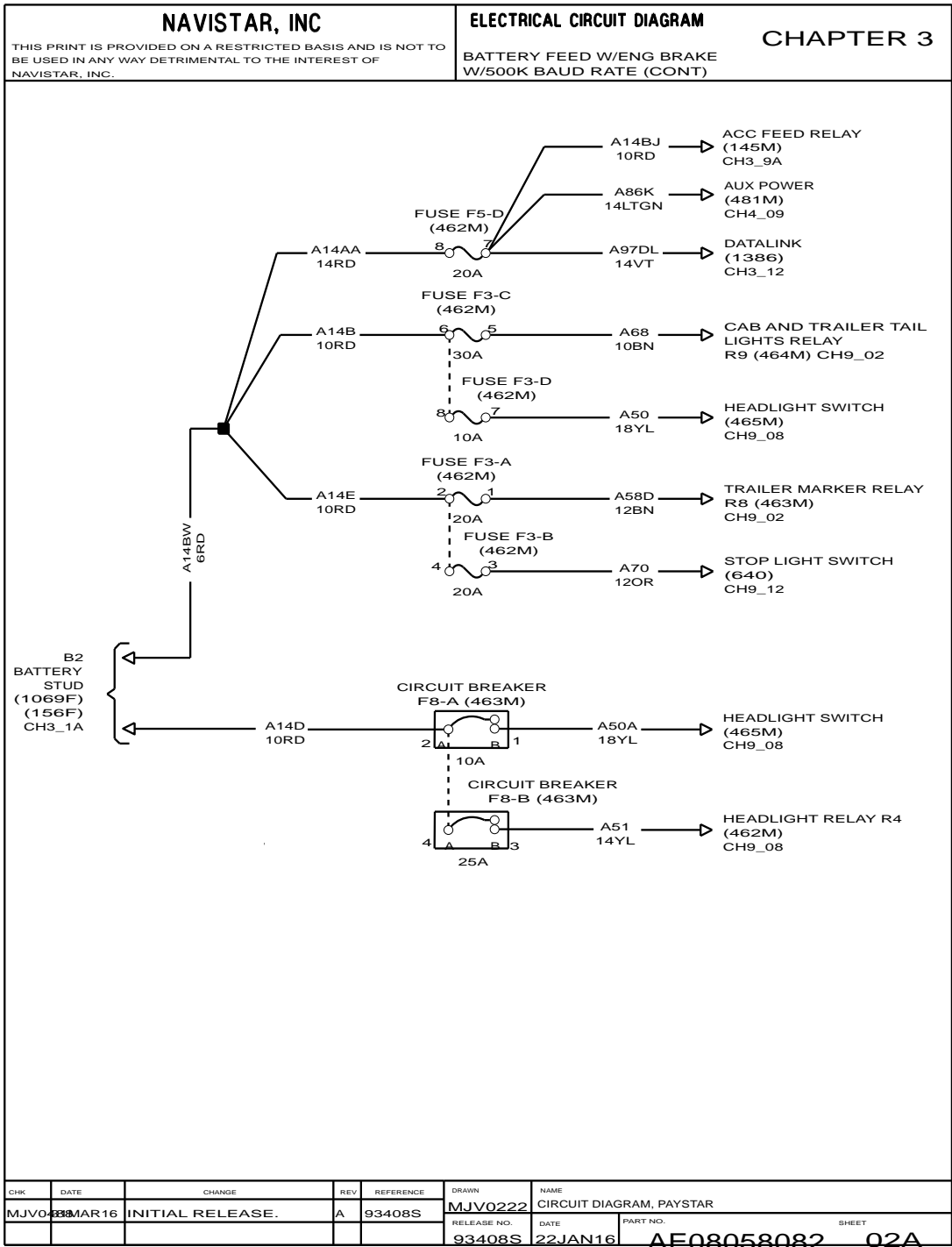


Figure 16 Battery Feed with Engine Brake with 500K Baud Rate (Cont.)

3.5. BATTERY FEED WITH ENGINE BRAKE (CONT.), P. 3

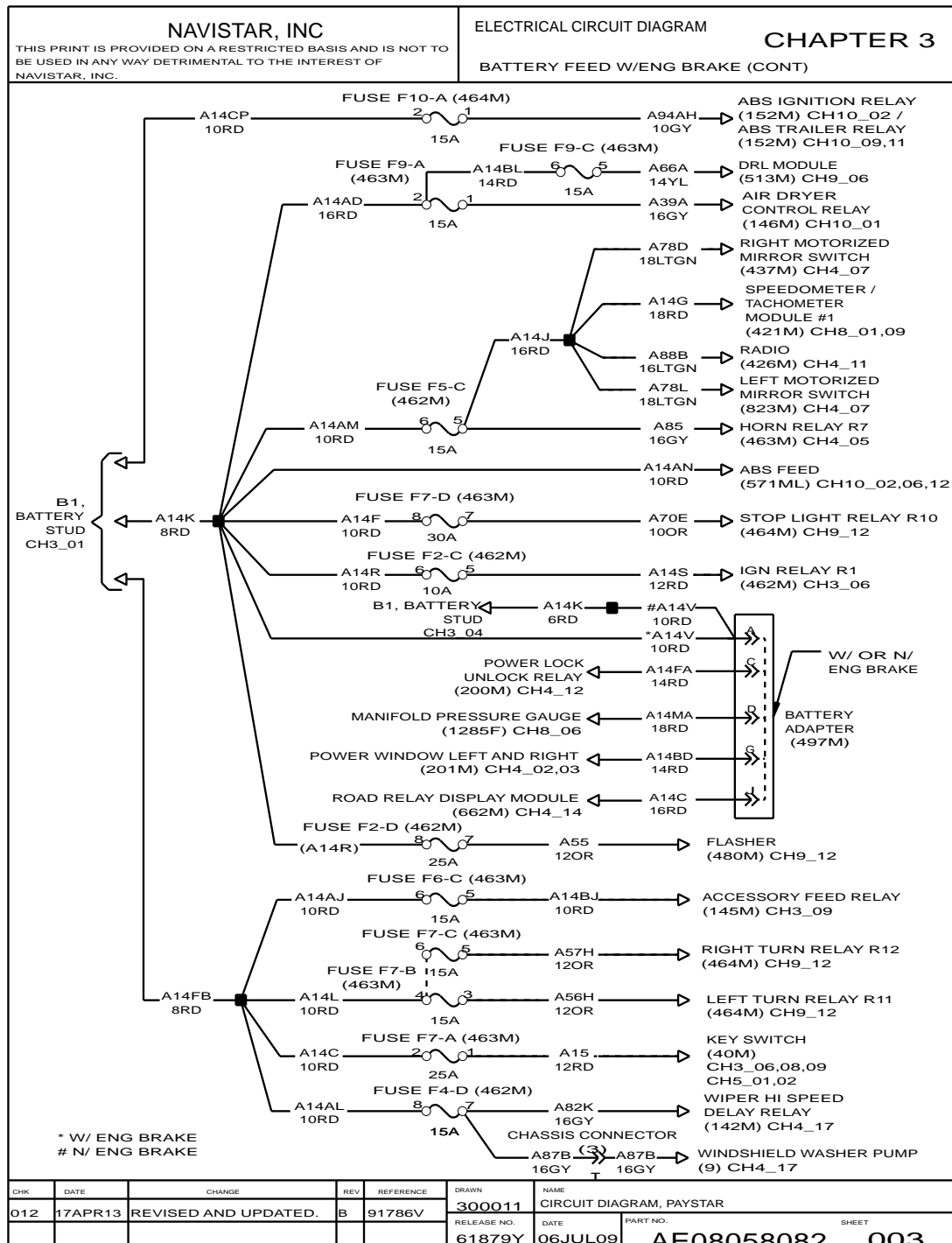


Figure 17 Battery Feed with Engine Brake (Cont.)

3.6. BATTERY FEED WITH ENGINE BRAKE WITH 500K BAUD RATE (CONT.), P. 3A

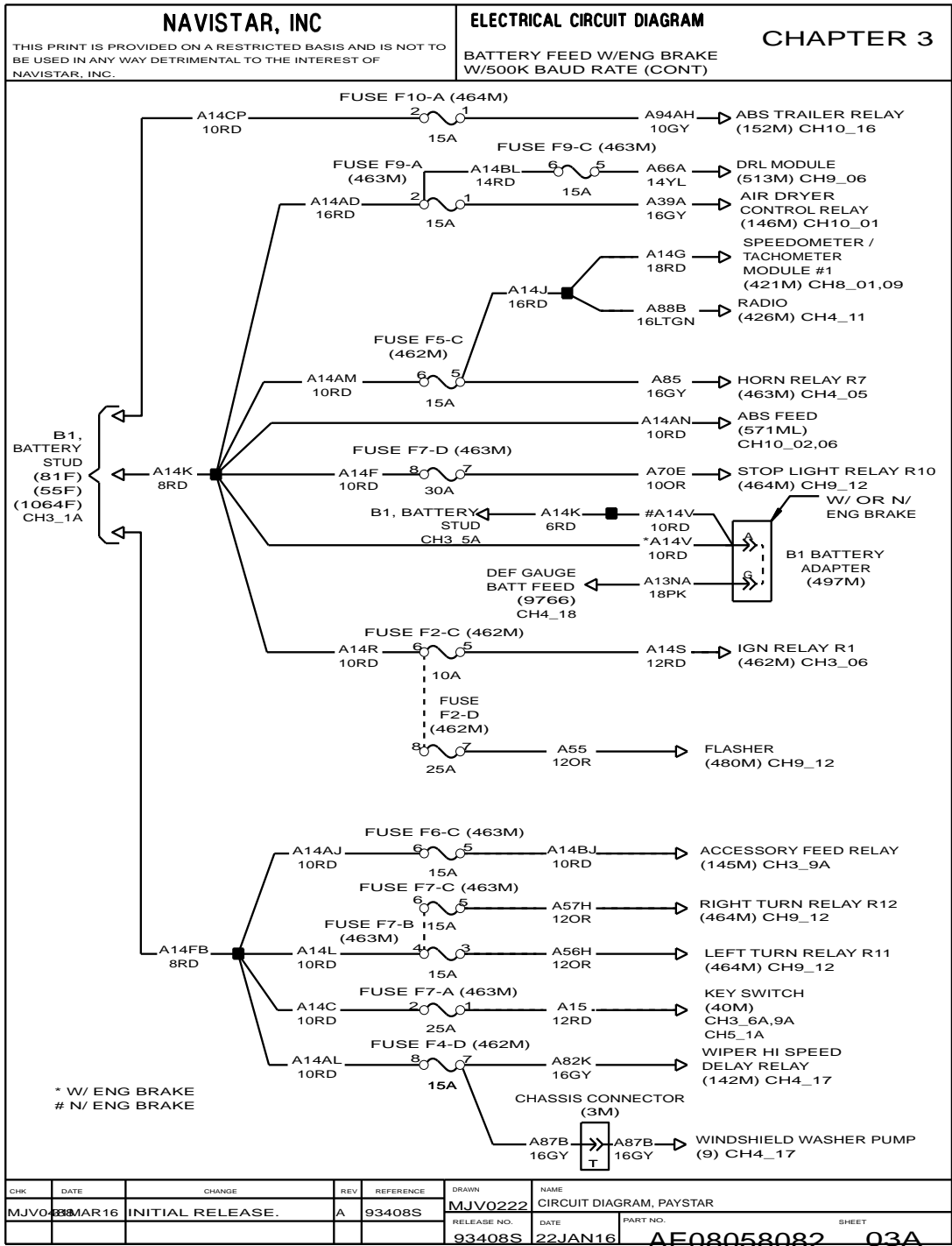


Figure 18 Battery Feed with Engine Brake with 500K Baud Rate (Cont.)

3.7. BATTERY FEED WITHOUT ENGINE BRAKE, P. 4

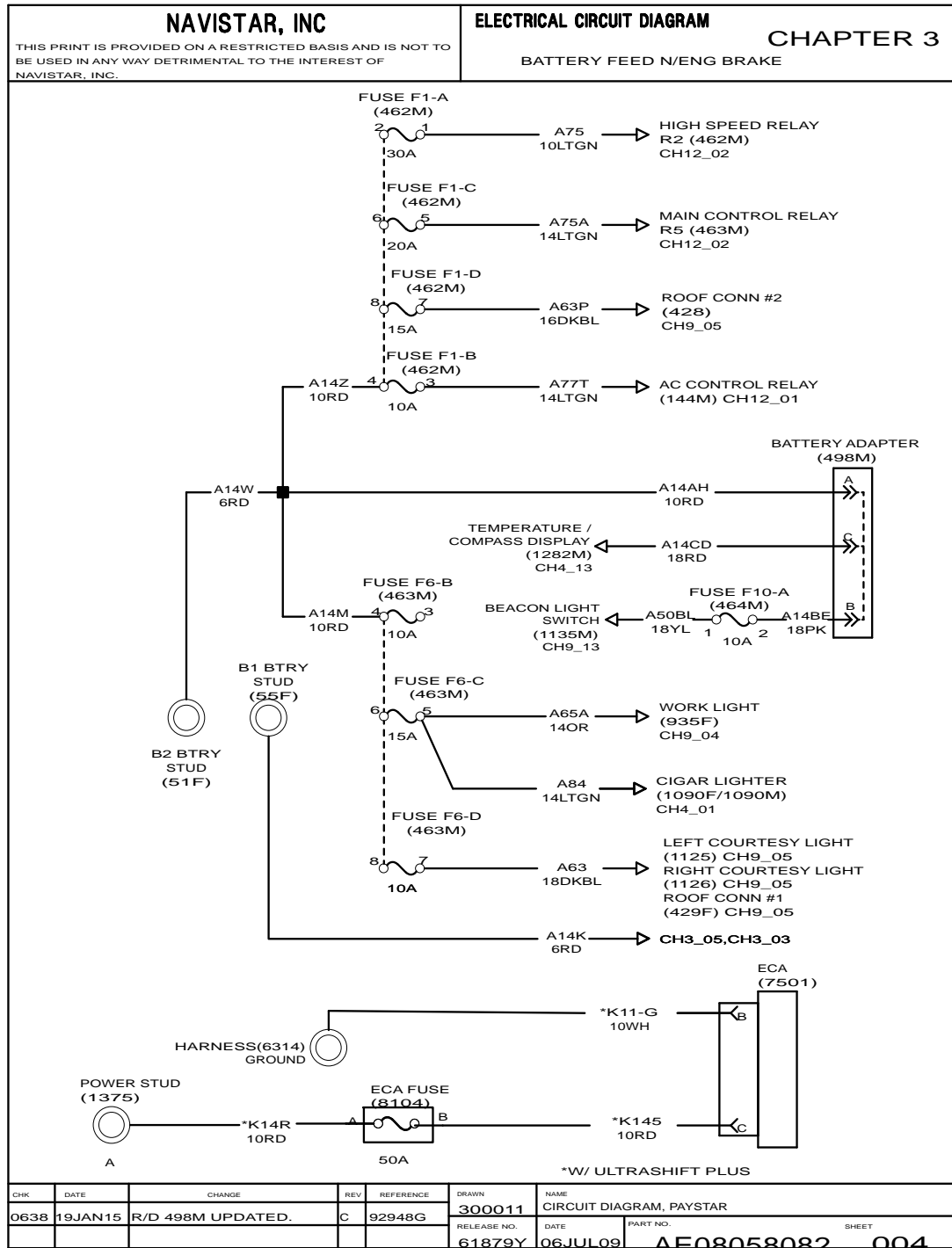


Figure 19 Battery Feed without Engine Brake

3.8. BATTERY FEED WITHOUT ENGINE BRAKE WITH 500K BAUD RATE, P. 4A

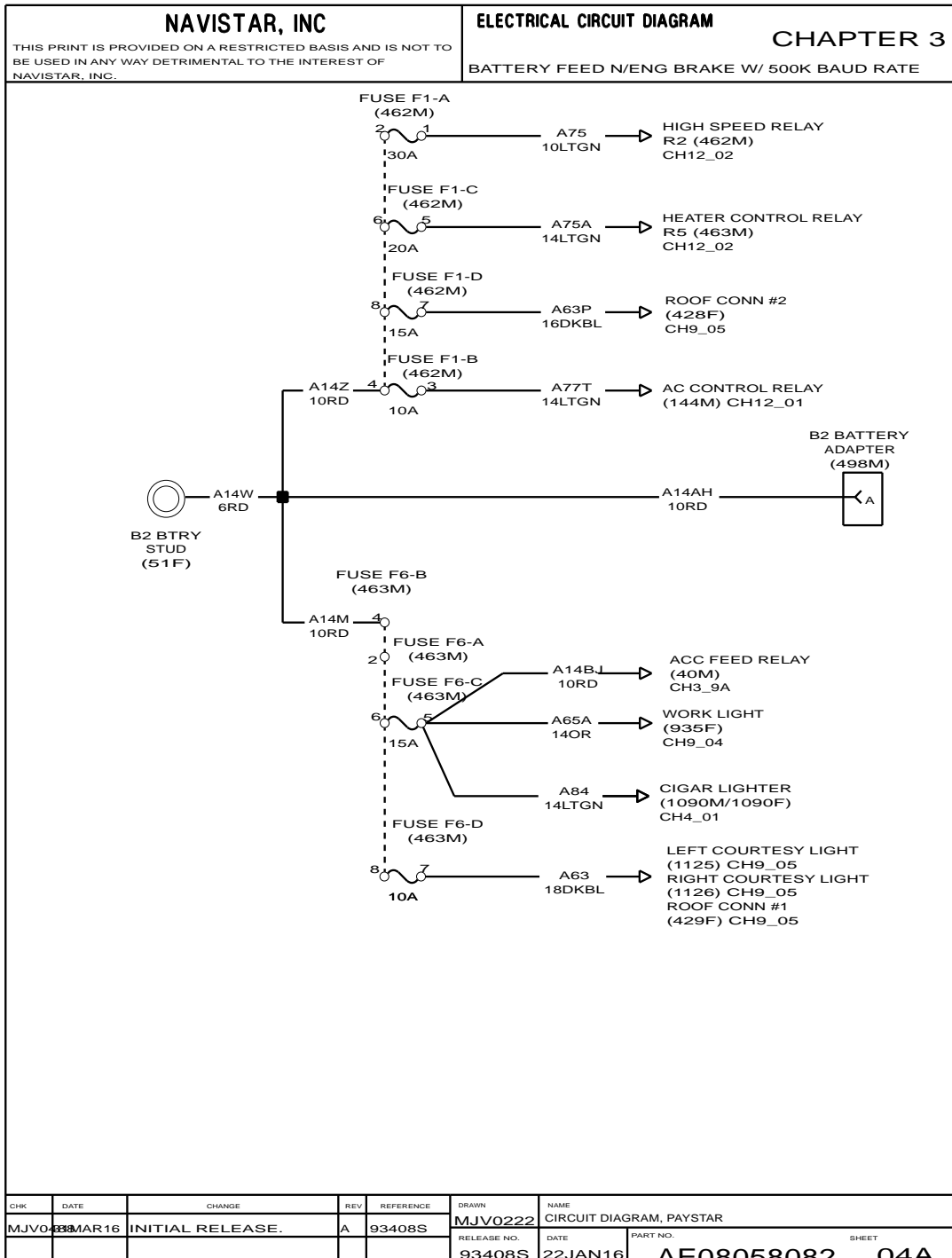


Figure 20 Battery Feed without Engine Brake with 500K Baud Rate

3.9. BATTERY FEED WITHOUT ENGINE BRAKE, P. 5

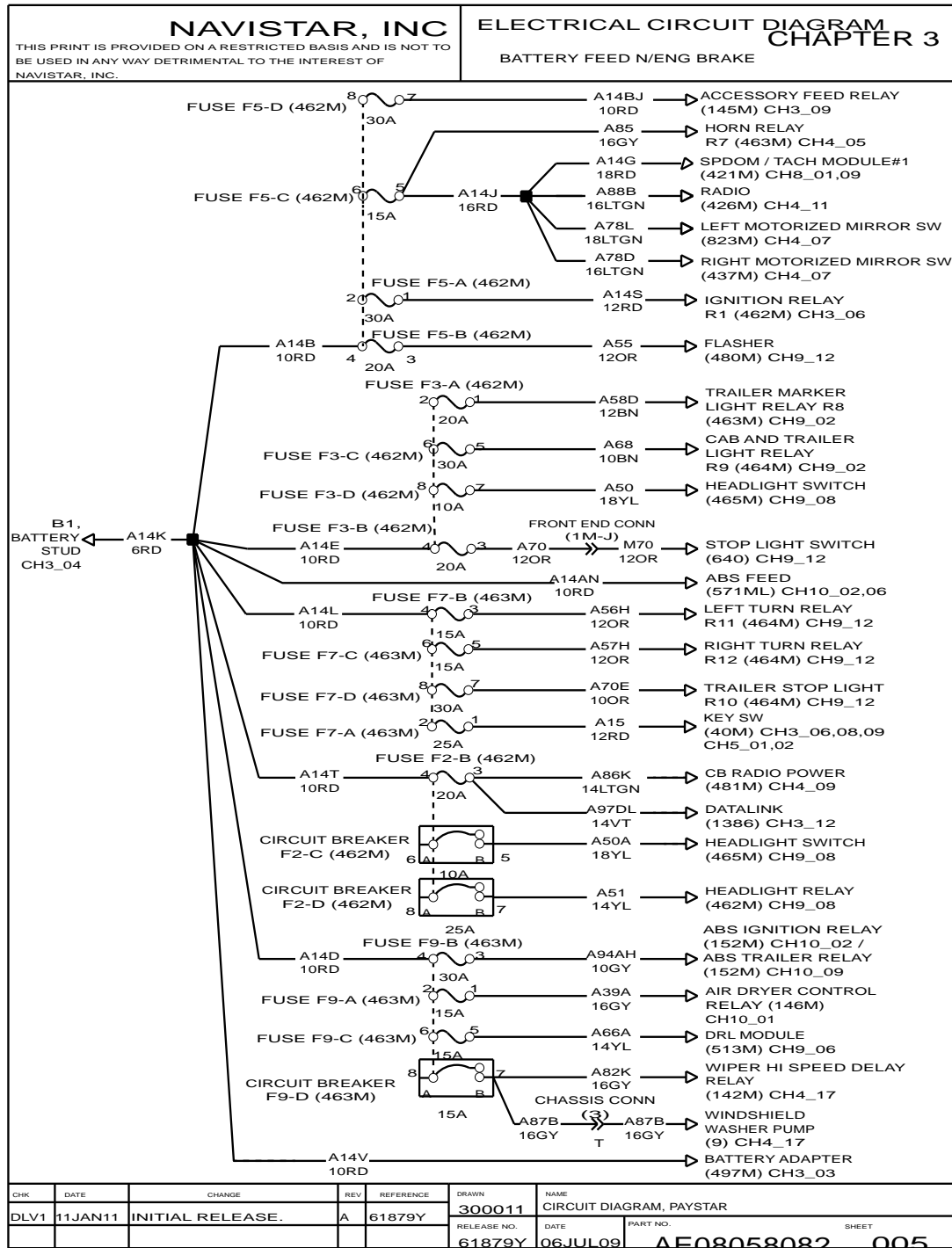


Figure 21 Battery Feed without Engine Brake

3.10. BATTERY FEED WITHOUT ENGINE BRAKE WITH 500K BAUD RATE (CONT.), P. 5A

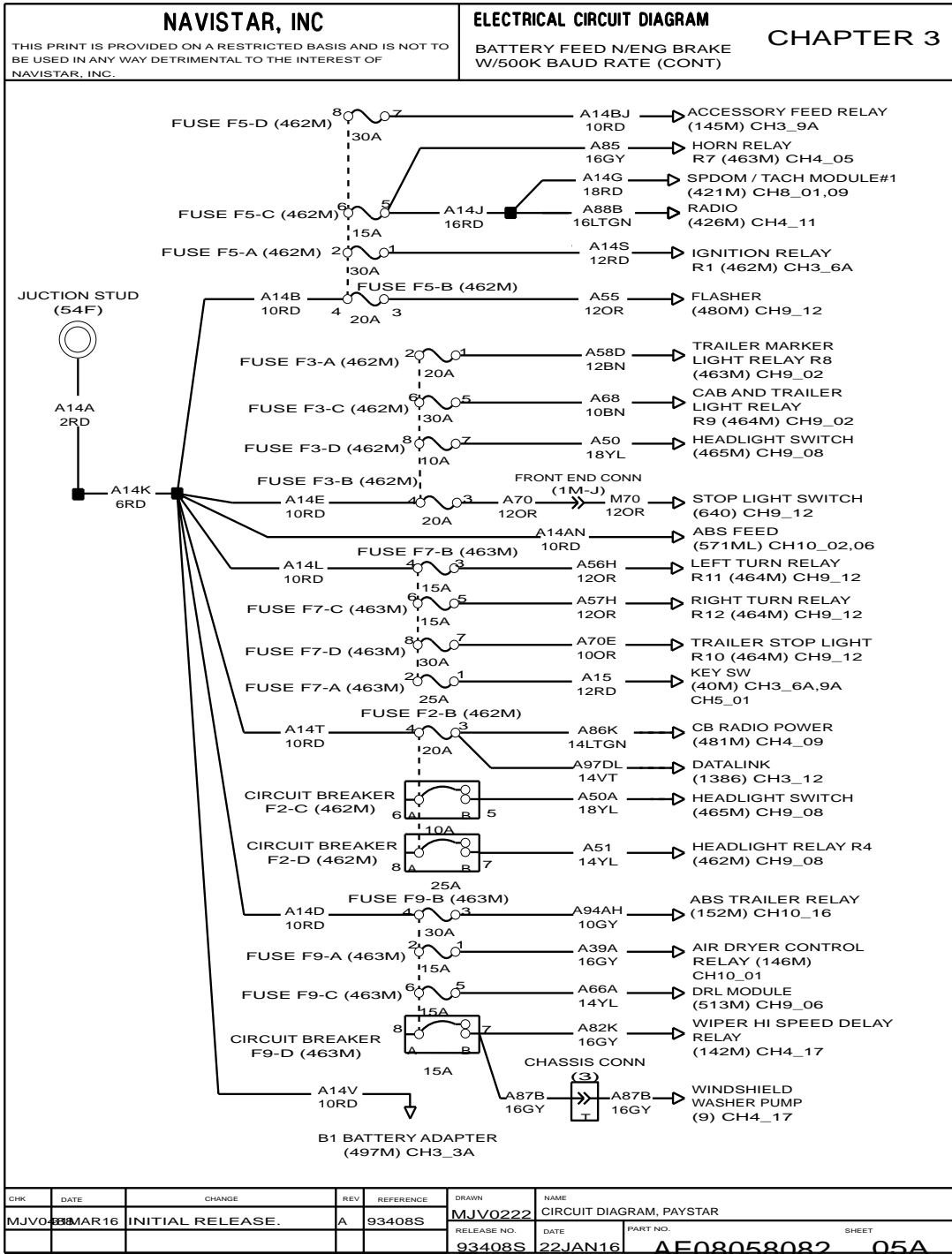


Figure 22 Battery Feed without Engine Brake with 500K Baud Rate (Cont.)



3.11. IGNITION FEED, P. 6

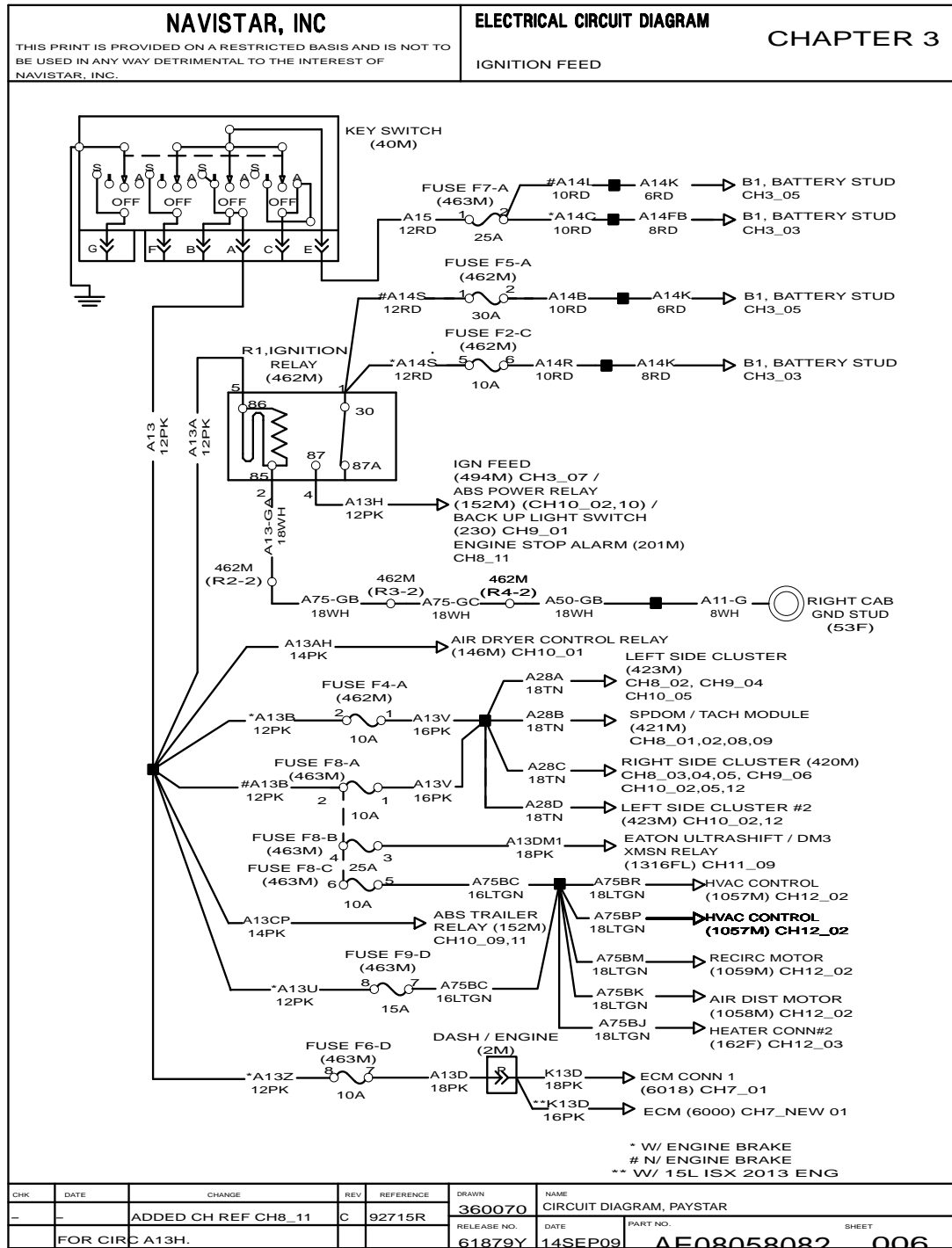


Figure 23 Ignition Feed

3.12. IGNITION FEED WITH 500K BAUD RATE, P. 6A

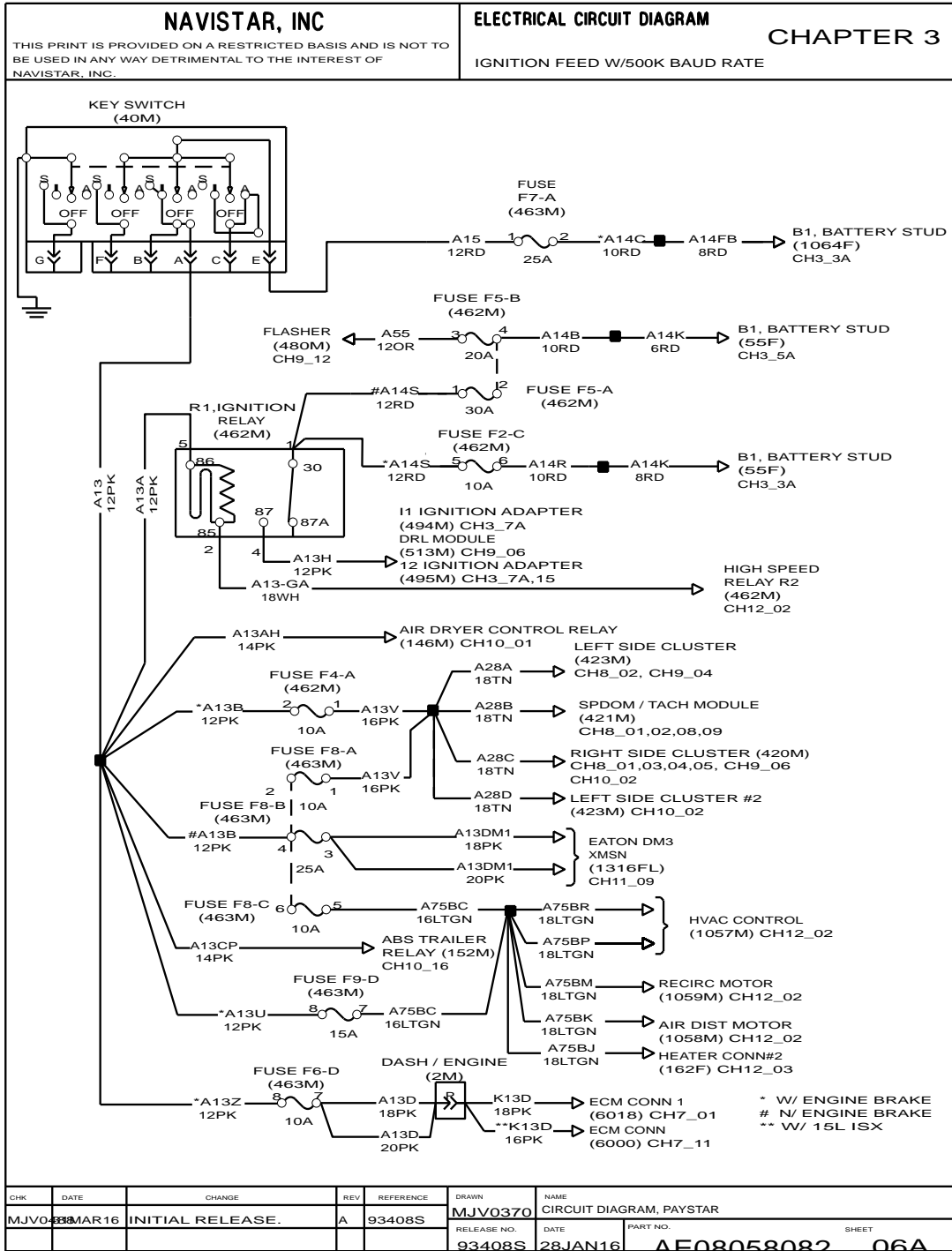


Figure 24 Ignition Feed with 500K Baud Rate

3.13. IGNITION FEED (CONT.), P. 7

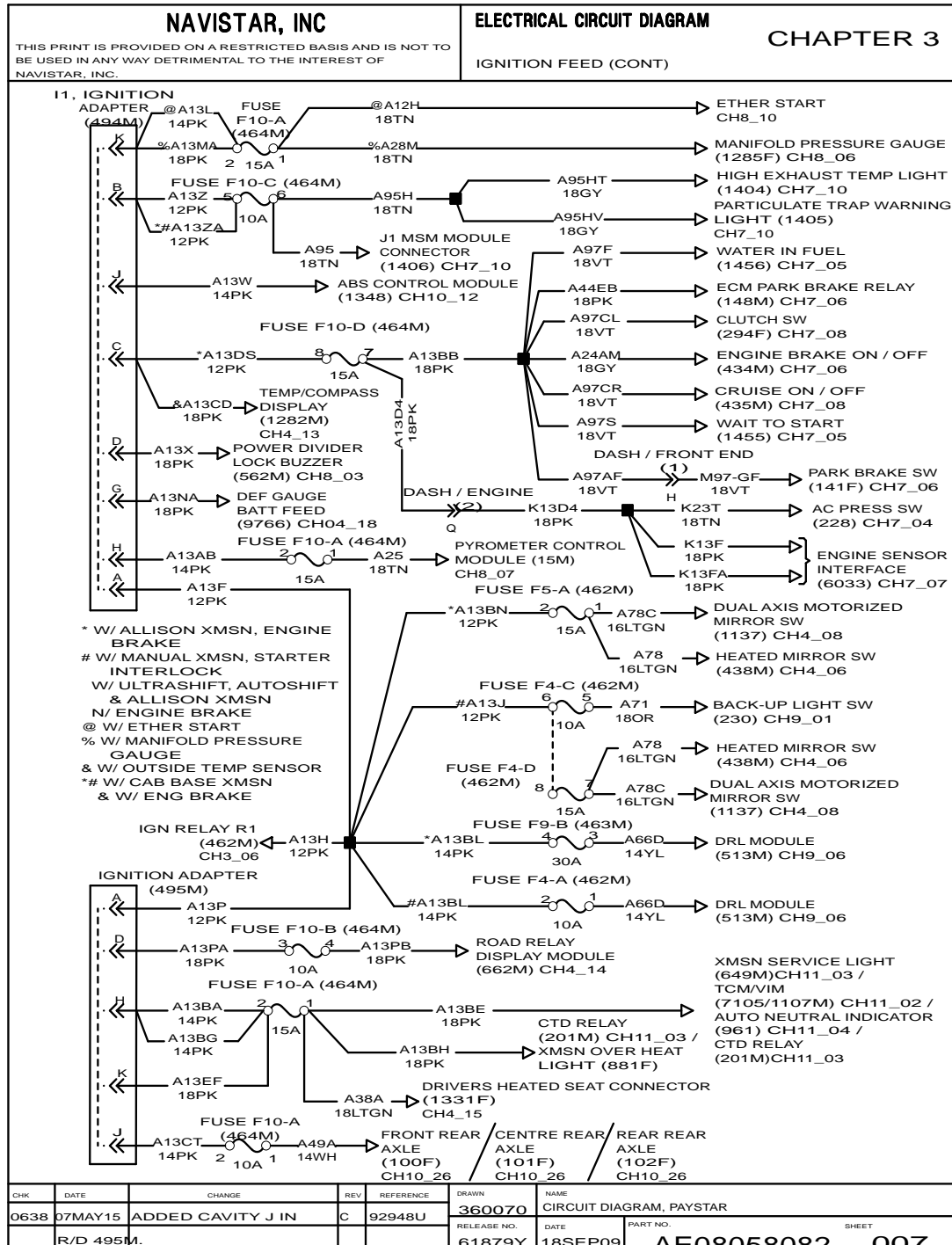


Figure 25 Ignition Feed (Cont.)

3.14. IGNITION FEED WITH 500K BAUD RATE (CONT.), P. 7A

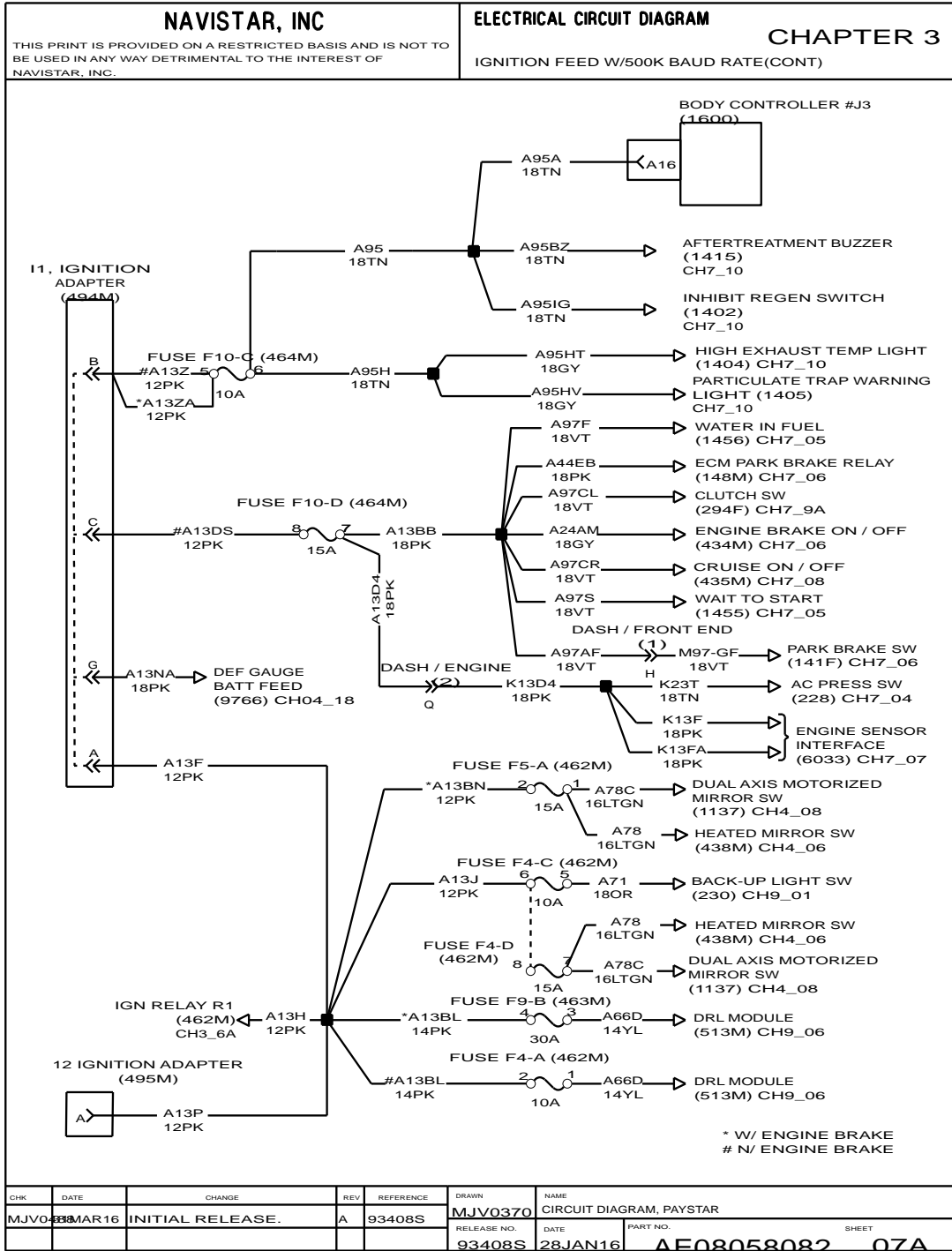


Figure 26 Ignition Feed with 500K Baud Rate (Cont.)

3.15. POWER FEED, P. 8

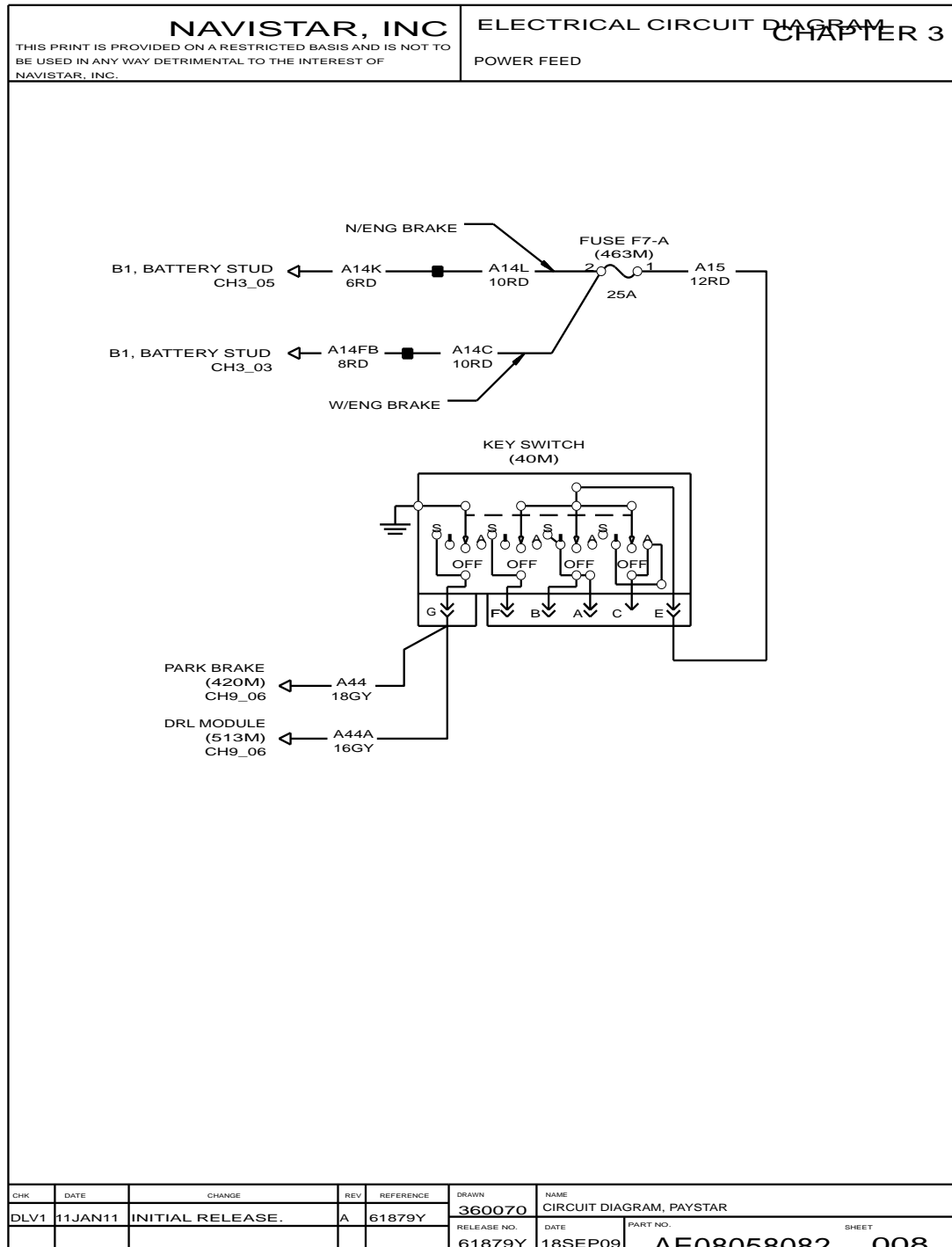


Figure 27 Power Feed

3.16. ACCESSORY FEED, P. 9

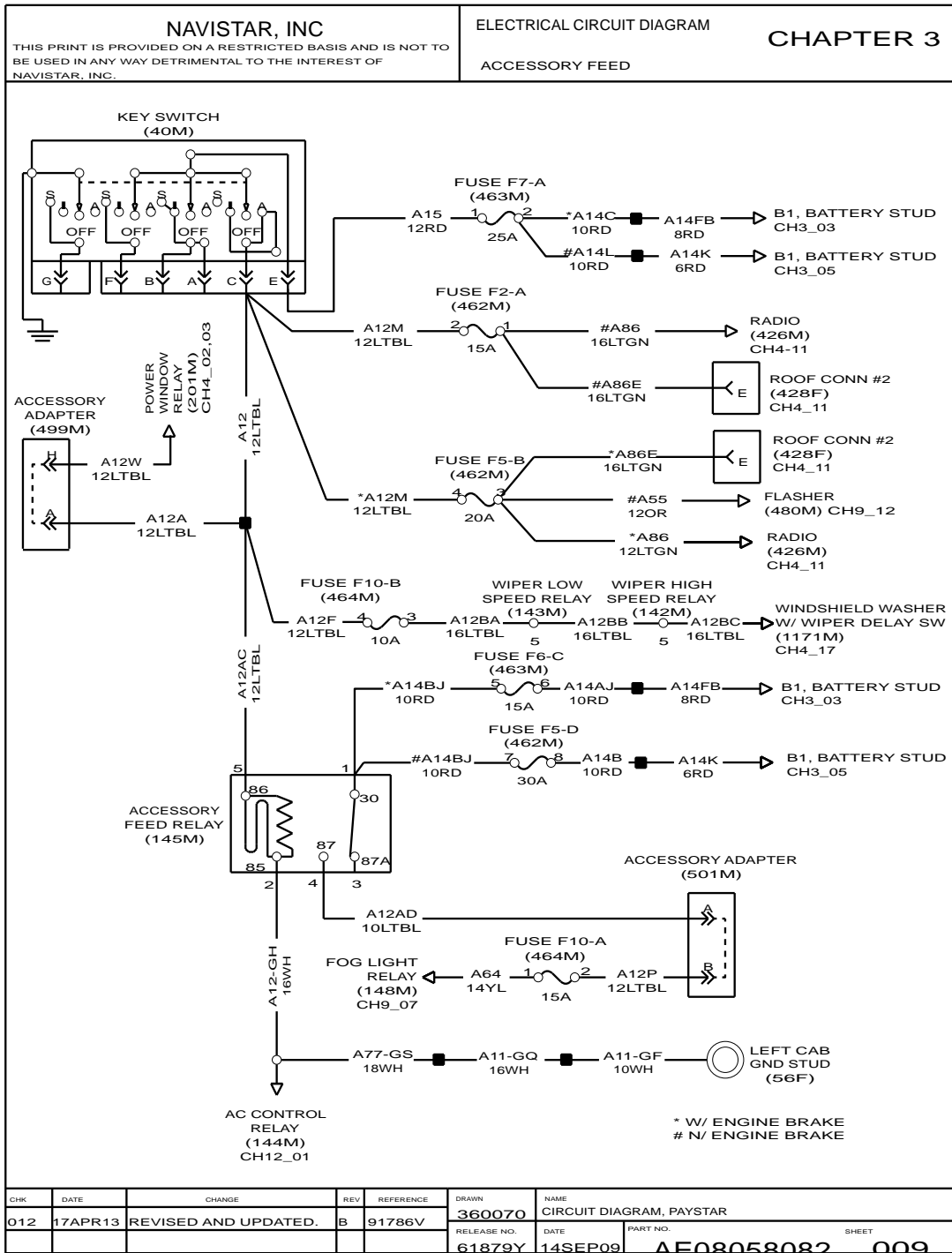


Figure 28 Accessory Feed



3.18. J1939 DATA LINK WITH IBB ENGINE, P. 10

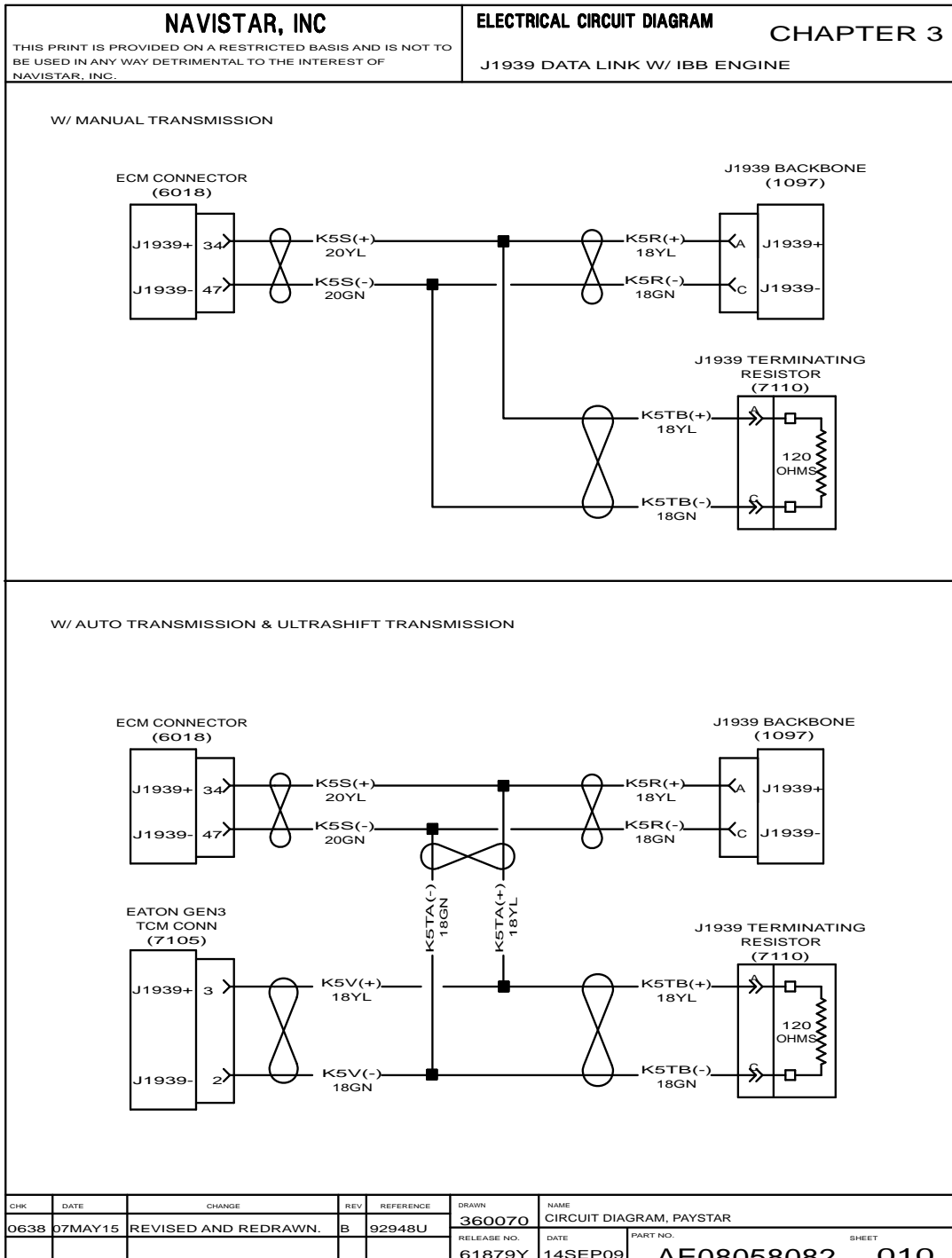


Figure 30 J1939 Data Link with IBB Engine



3.19. J1939 DATA LINK WITH IBB ENGINE (CONT.), P. 11

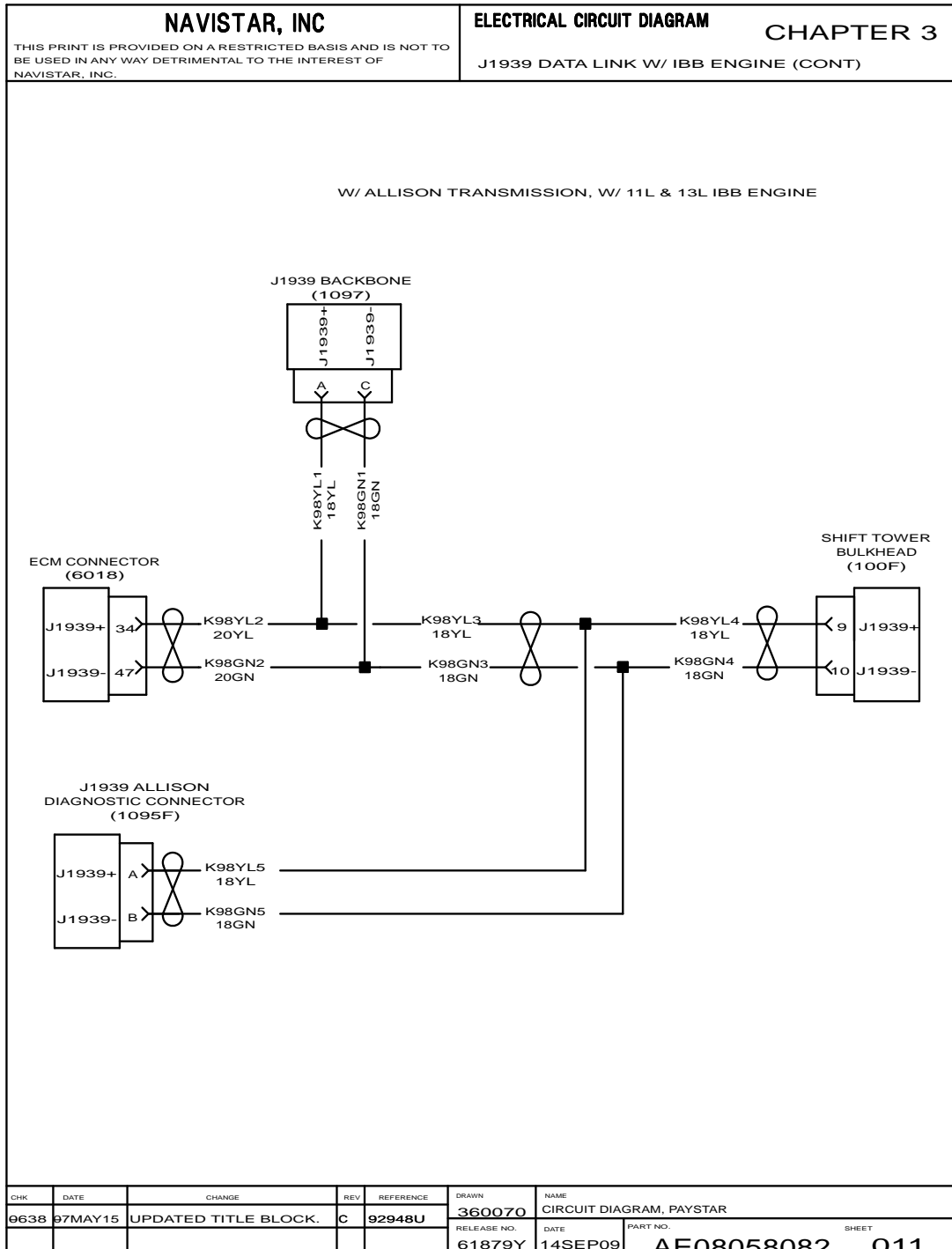


Figure 31 J1939 Data Link with IBB Engine (Cont.)

3.20. J1939 DATA LINK WITH IBB ENGINE (CONT.), P. 11A

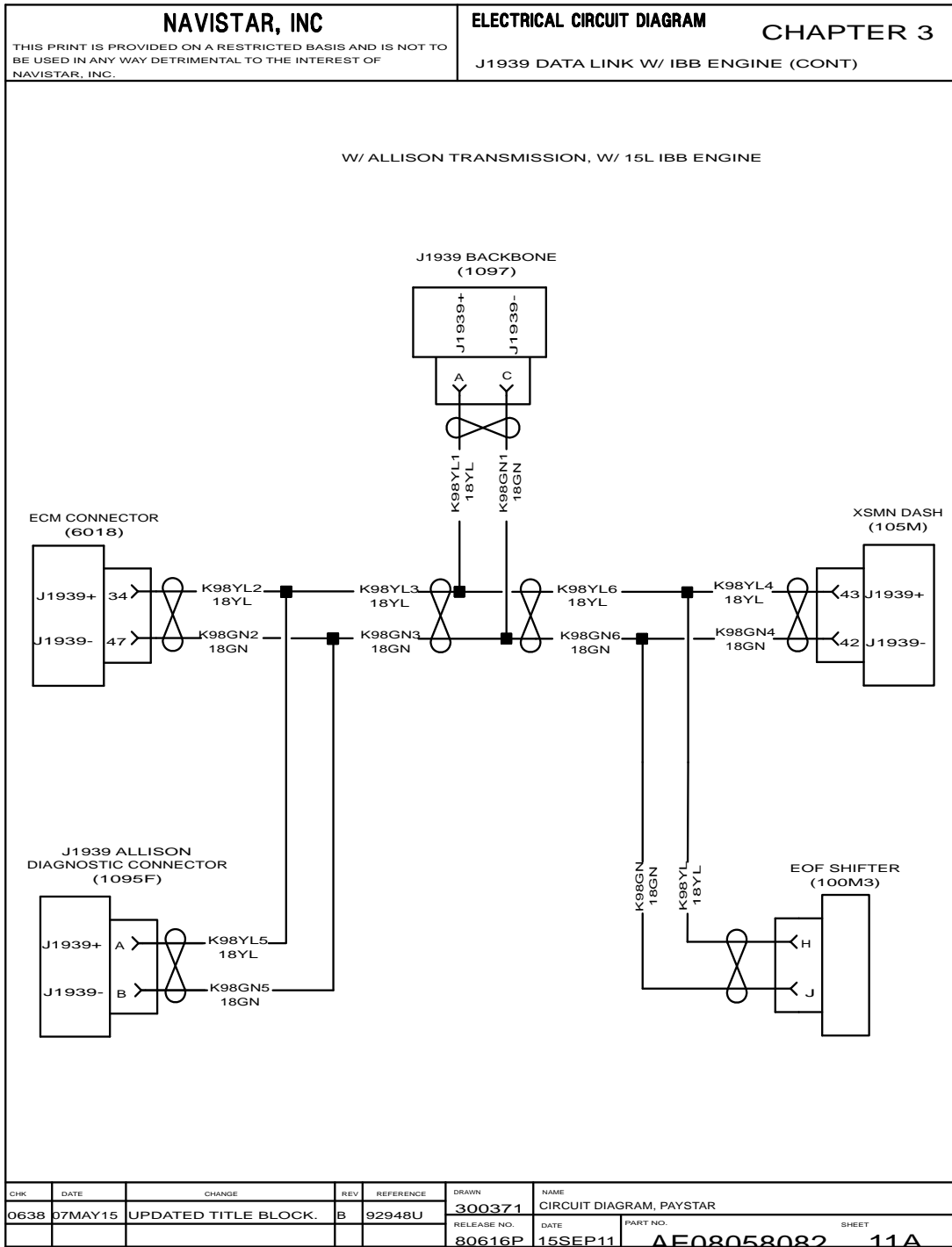


Figure 32 J1939 Data Link with IBB Engine (Cont.)

3.21. DIAGNOSTIC DATA LINK, P. 12

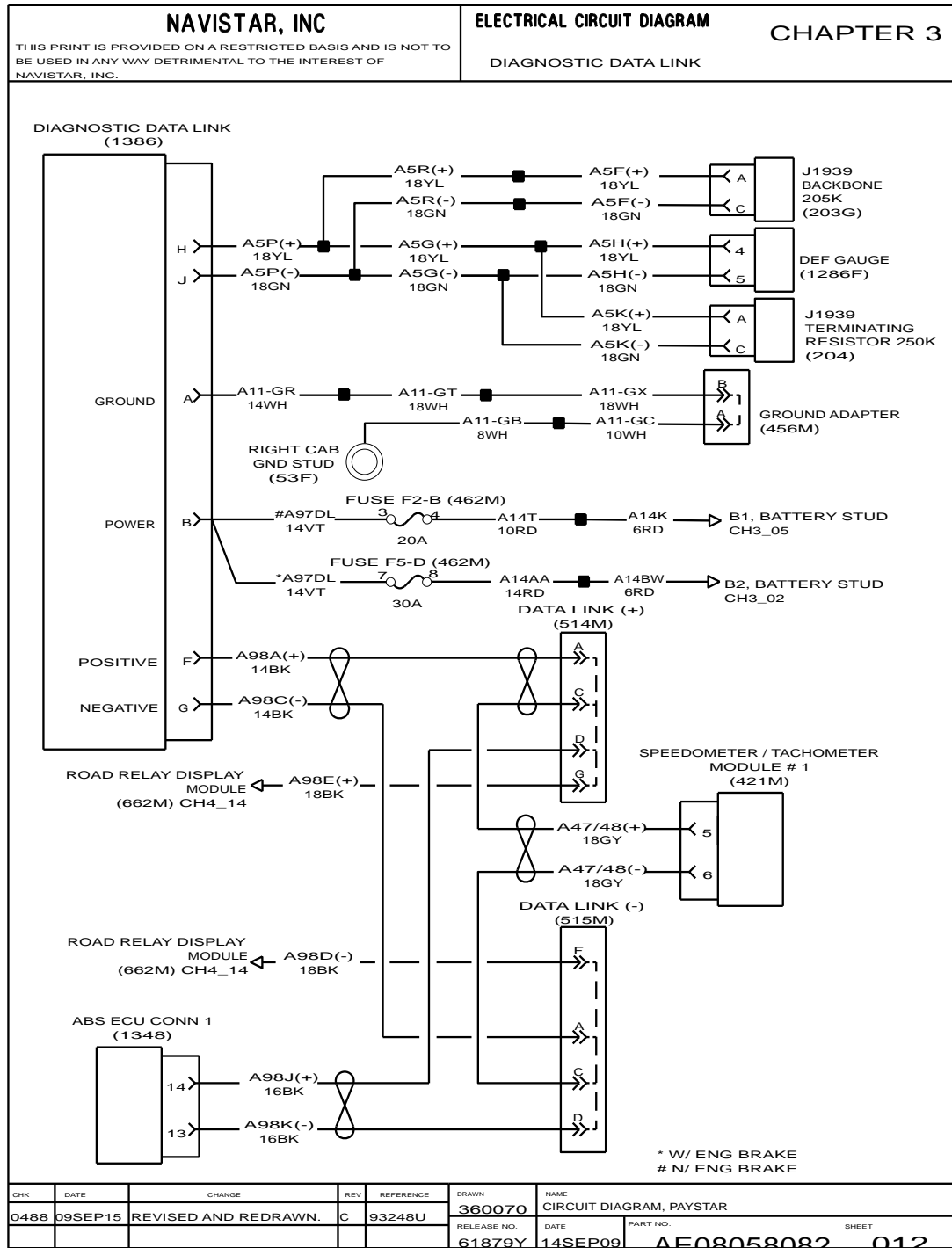


Figure 33 Diagnostic Data Link

3.22. GROUND, P. 13

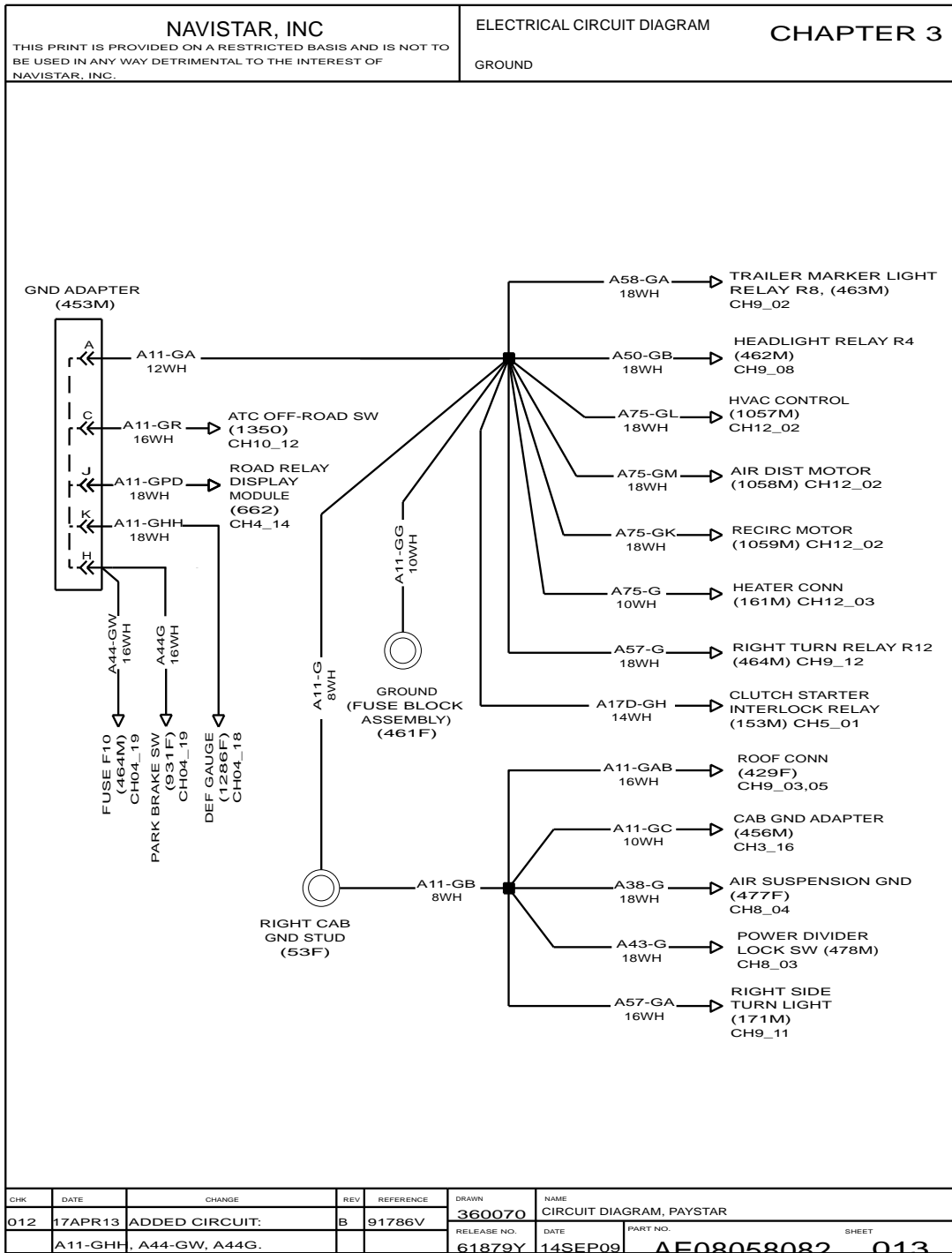


Figure 34 Ground

3.23. GROUND (CONT.), P. 14

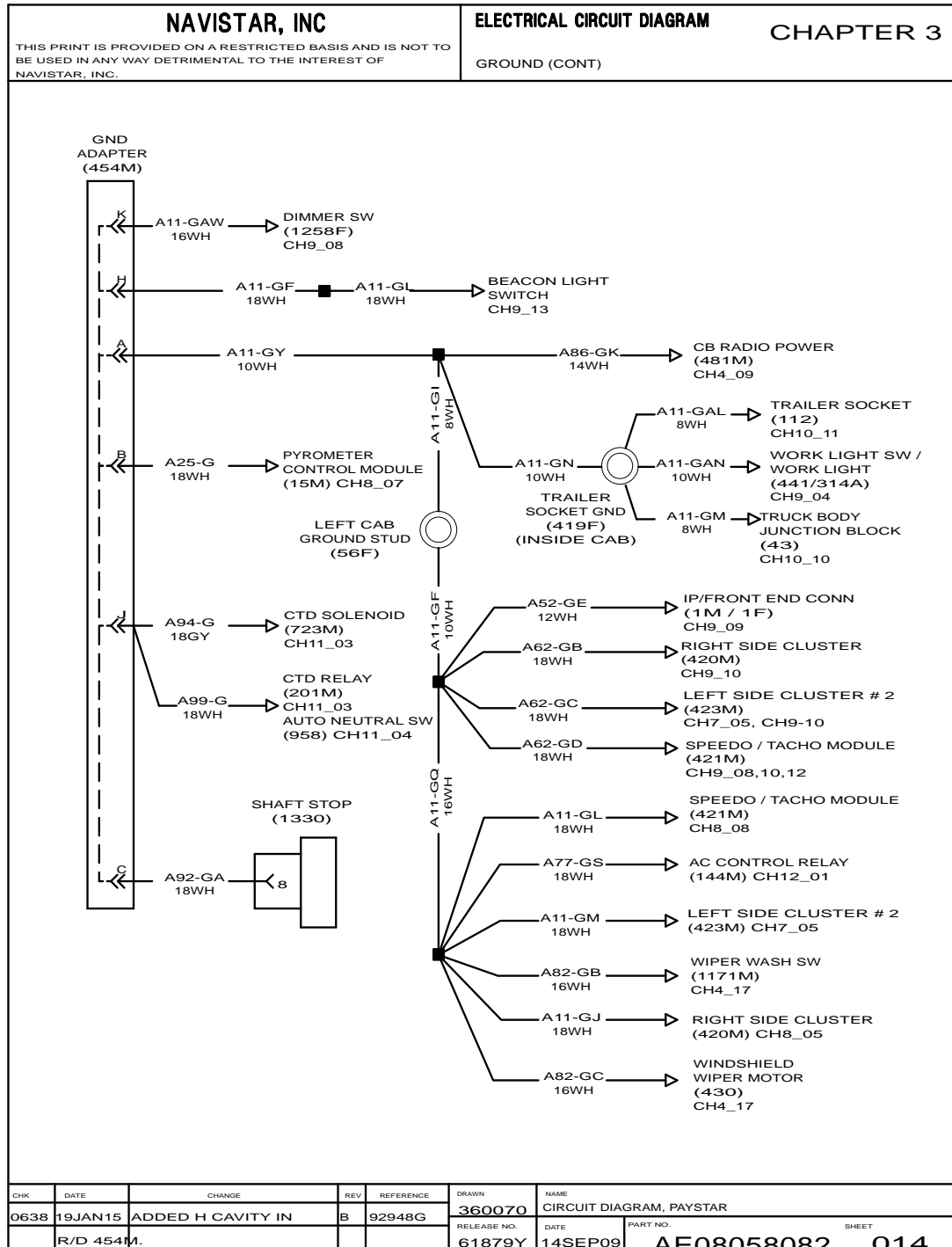


Figure 35 Ground (Cont.)

3.24. GROUND (CONT.), P. 15

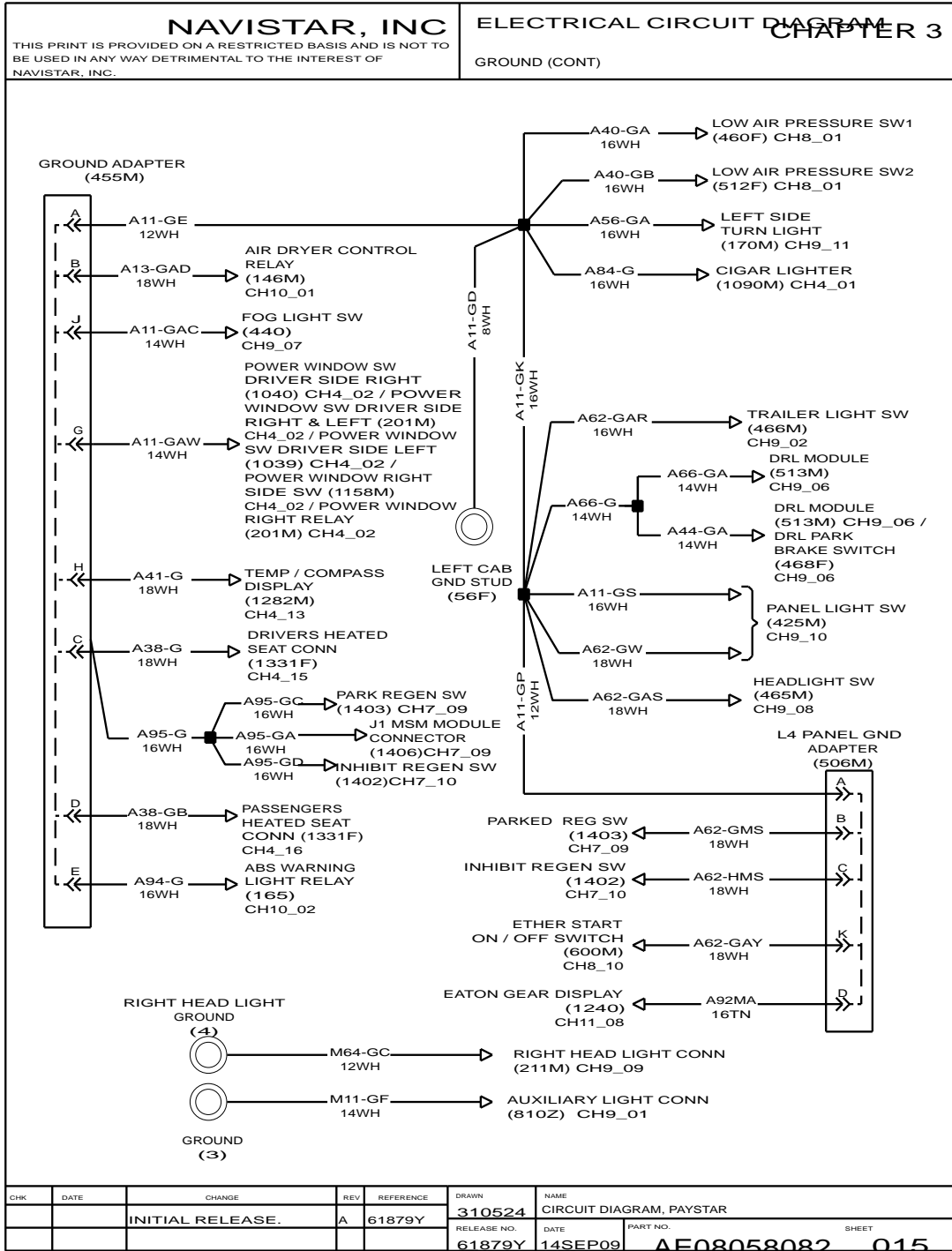


Figure 36 Ground (Cont.)

3.25. GROUND (CONT.), P. 16

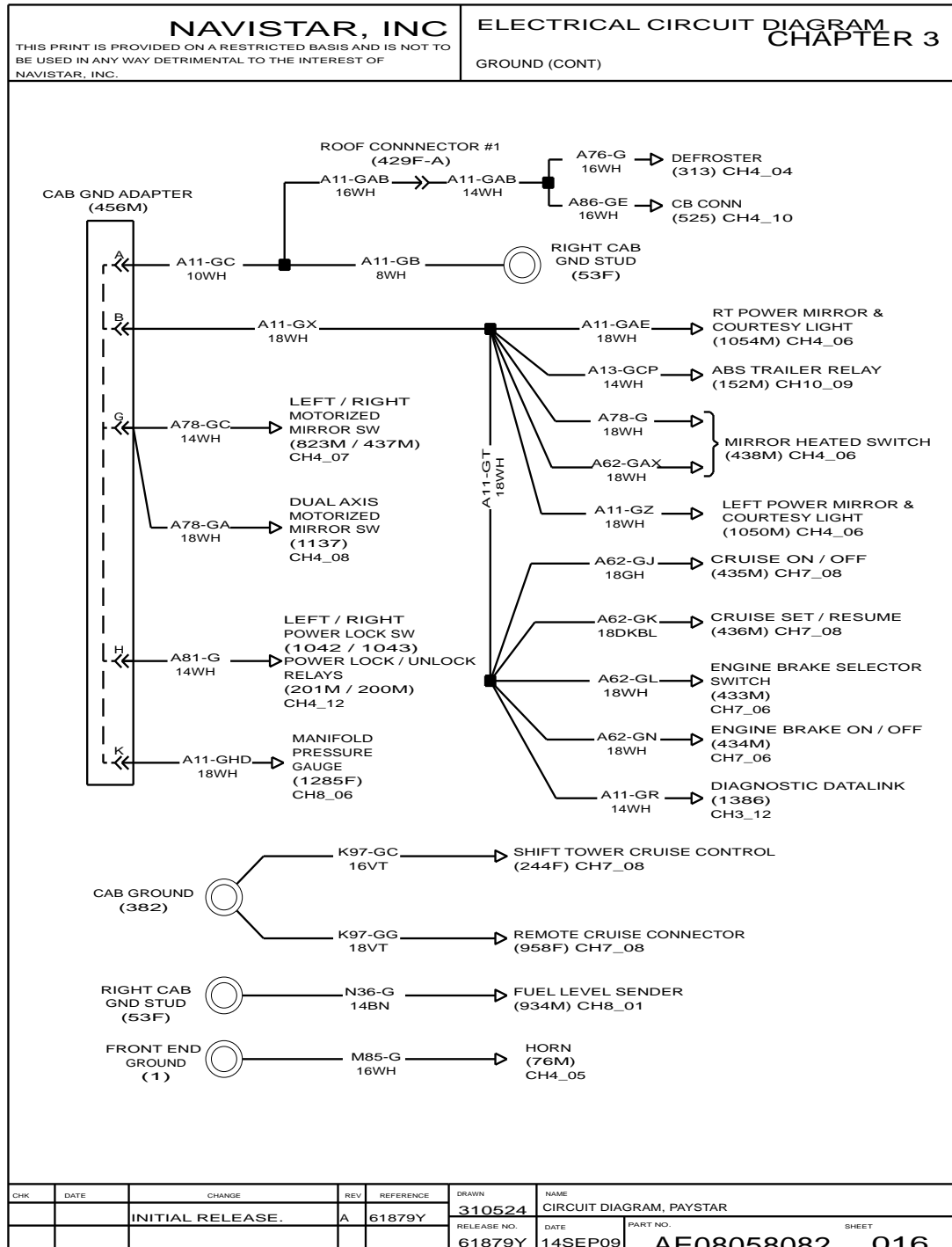


Figure 37 Ground (Cont.)

3.26. GROUND CHASSIS, P. 16A

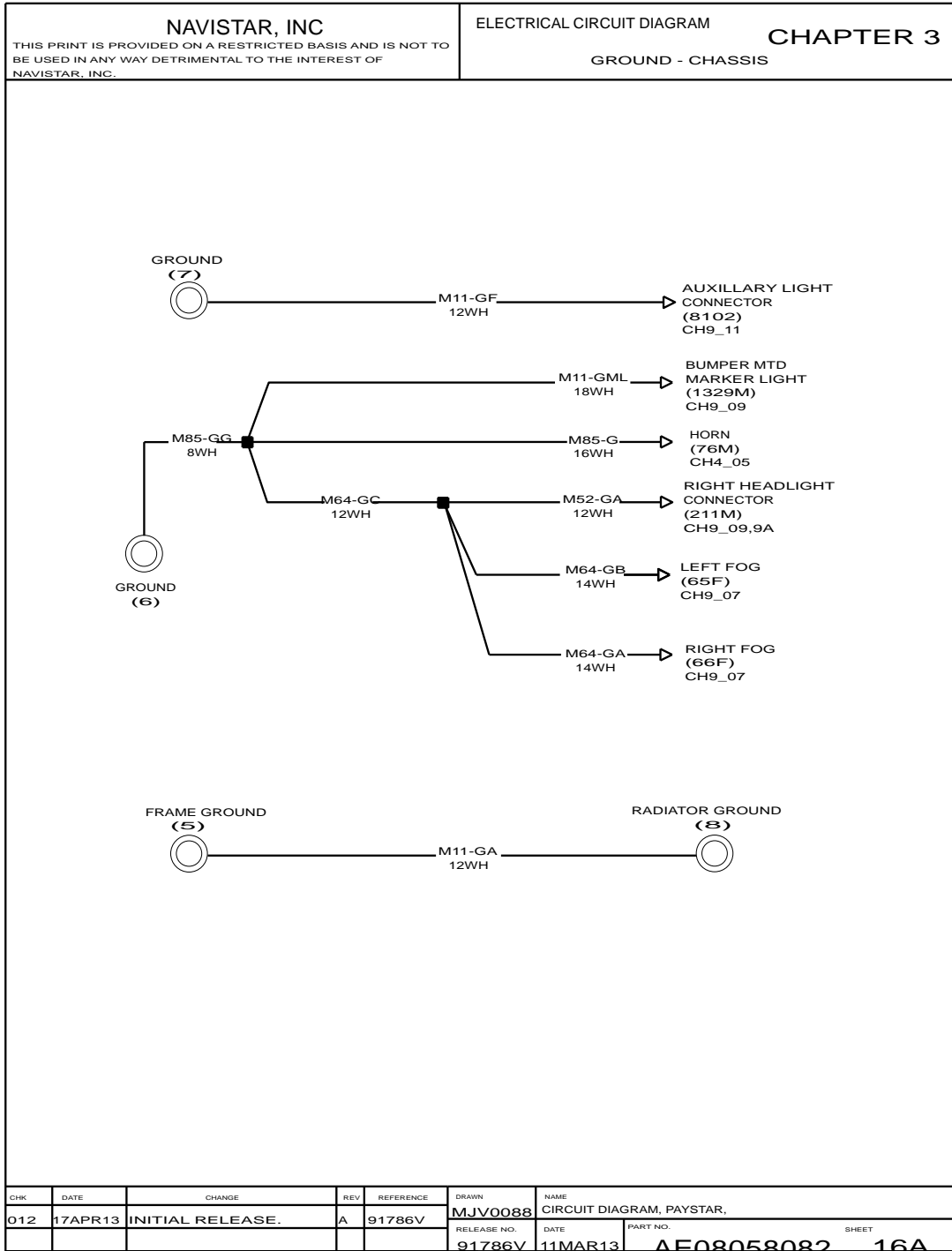


Figure 38 Ground Chassis





3.28. PANEL LIGHT ADAPTER, P. 18

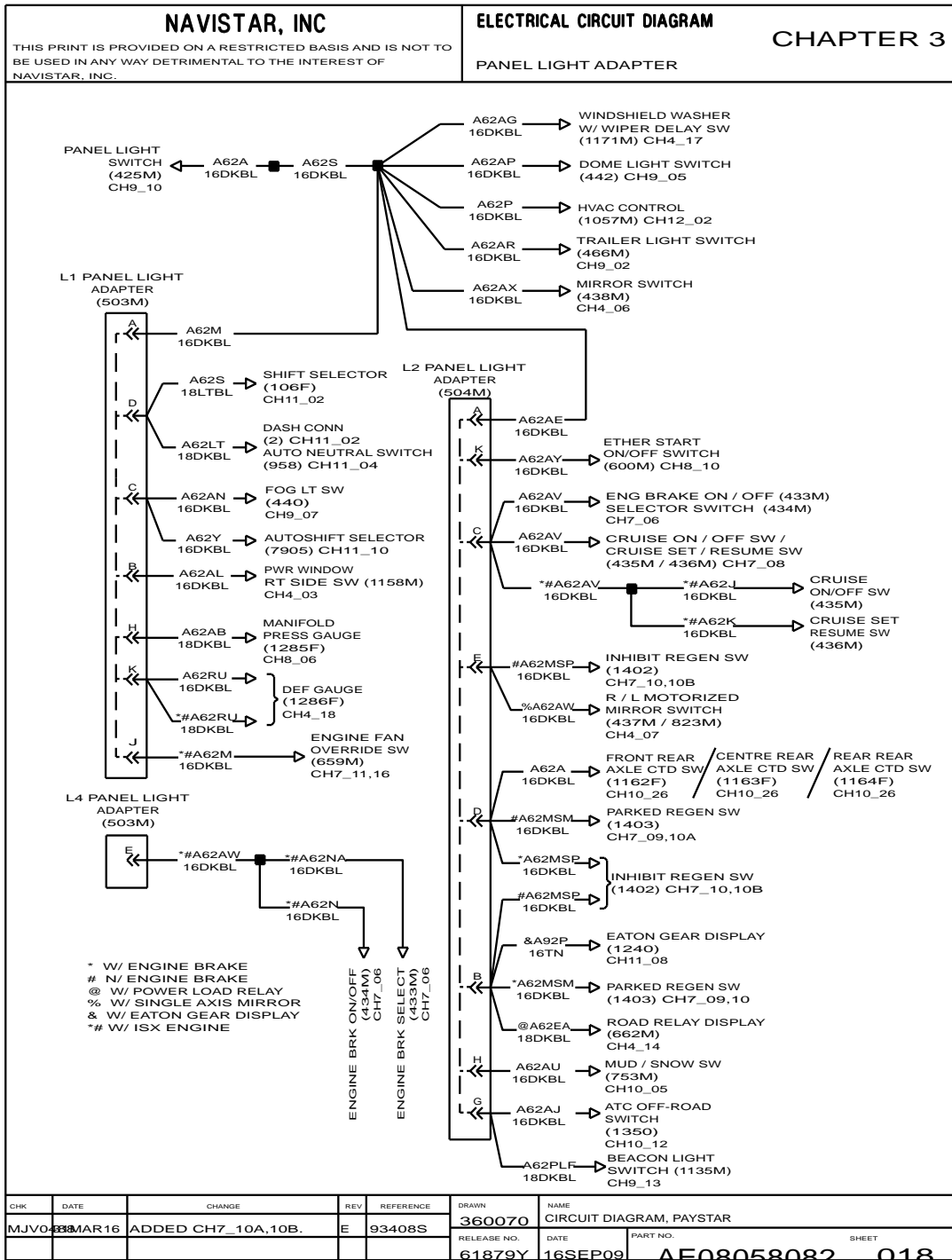


Figure 40 Panel Light Adapter

3.29. ECA POWER, P. 19

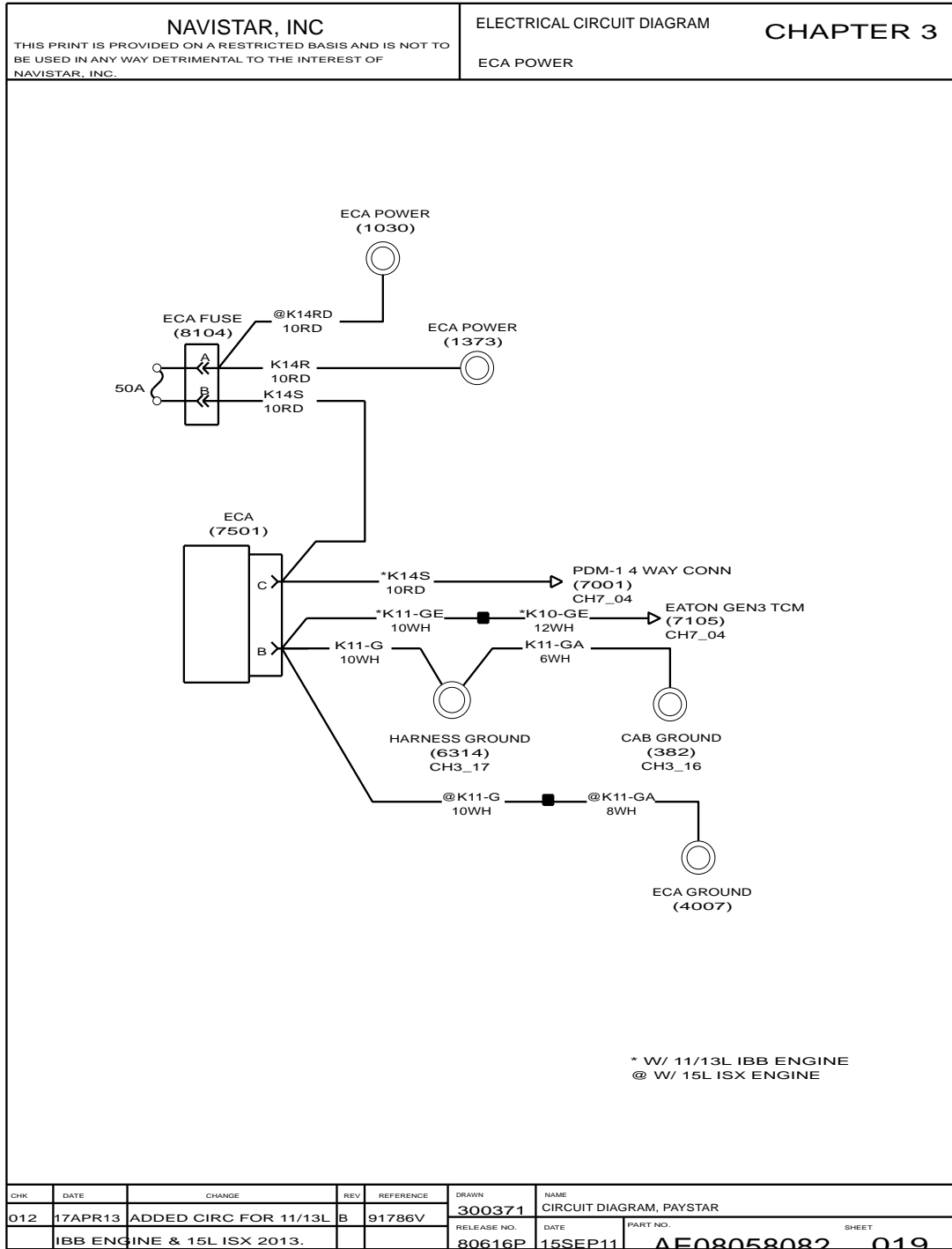


Figure 41 ECA Power

3.30. J1939 DATA LINK WITH 15L ISX 2013, P. 20

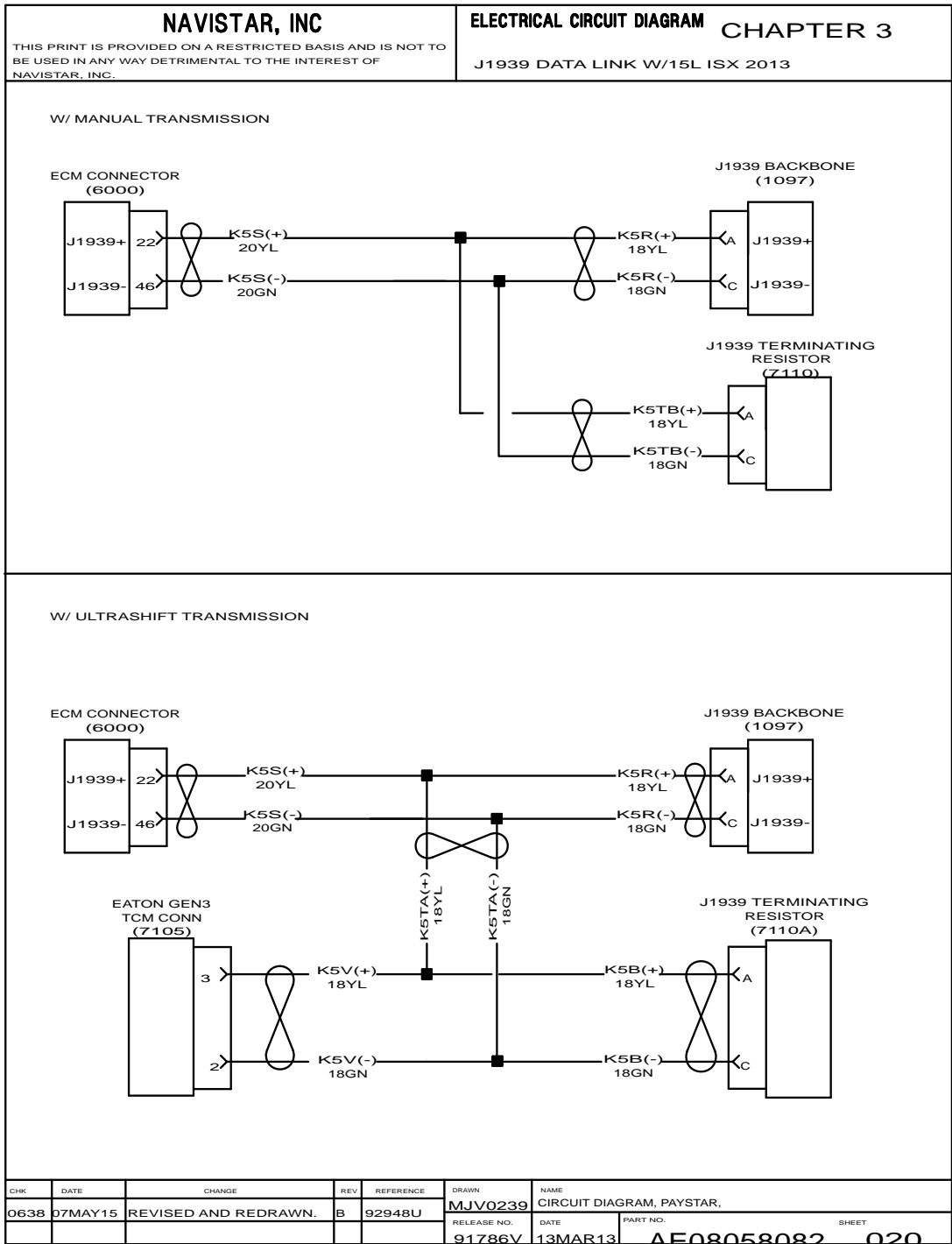


Figure 42 J1939 Data Link with 15L ISX 2013

3.31. CAB J1939 DATA LINK WITH 11 / 13L IBB SCR, P. 21

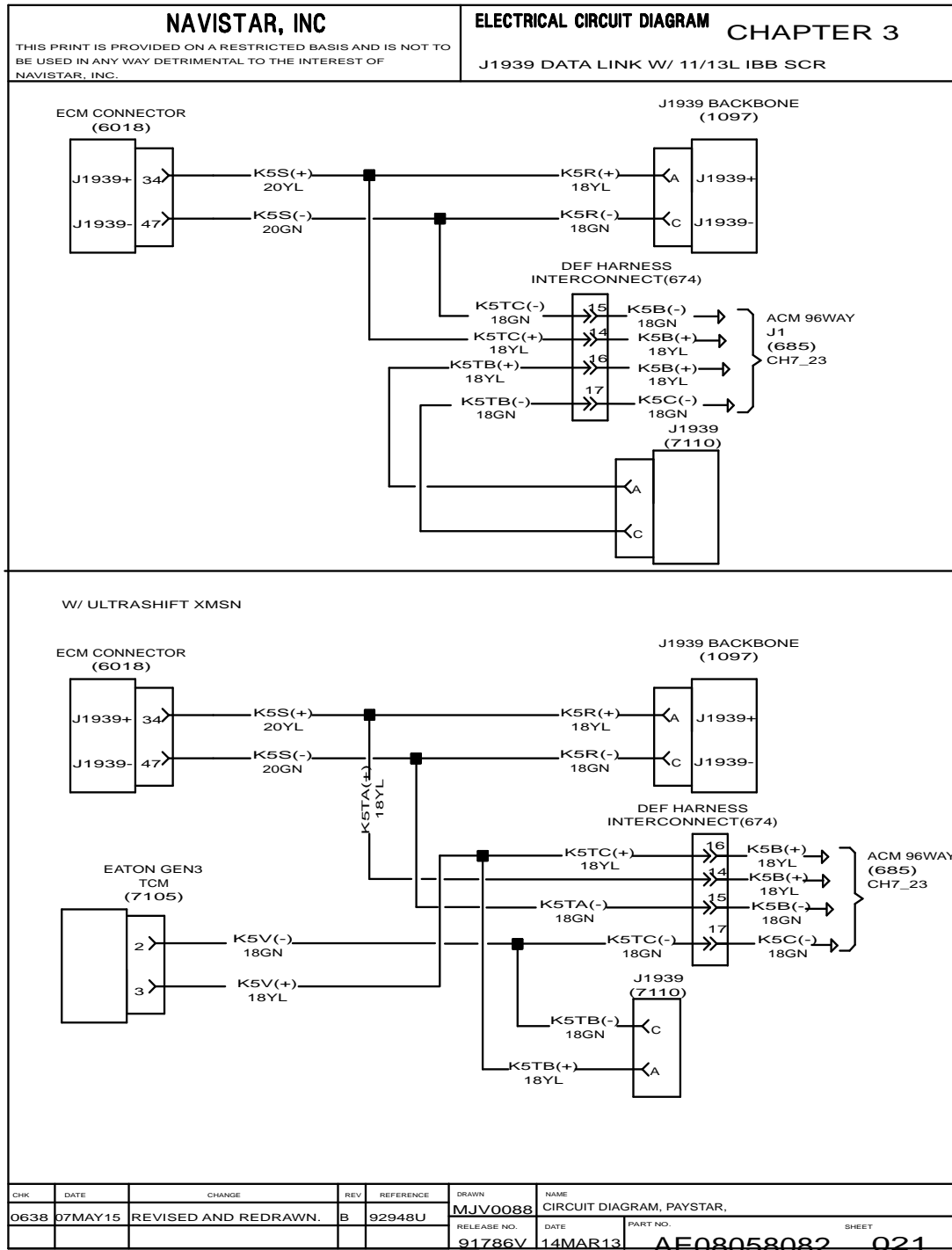


Figure 43 Cab J1939 Data Link with 11 / 13L IBB SCR

3.32. ECM SWITCH GND SPLICE, P. 22

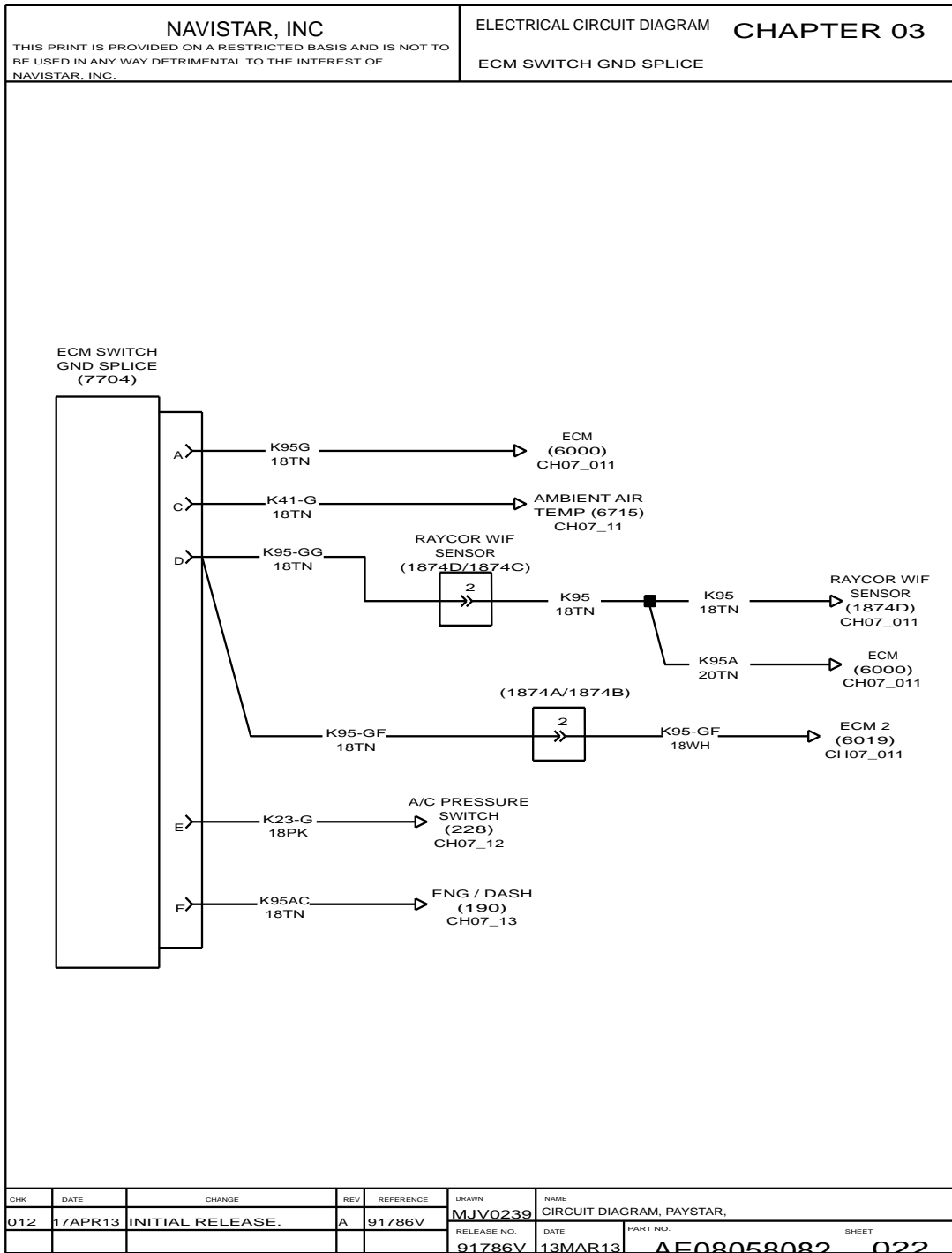


Figure 44 ECM Switch GND Splice

3.33. ECM SWITCH GND SPLICE 2, P. 23

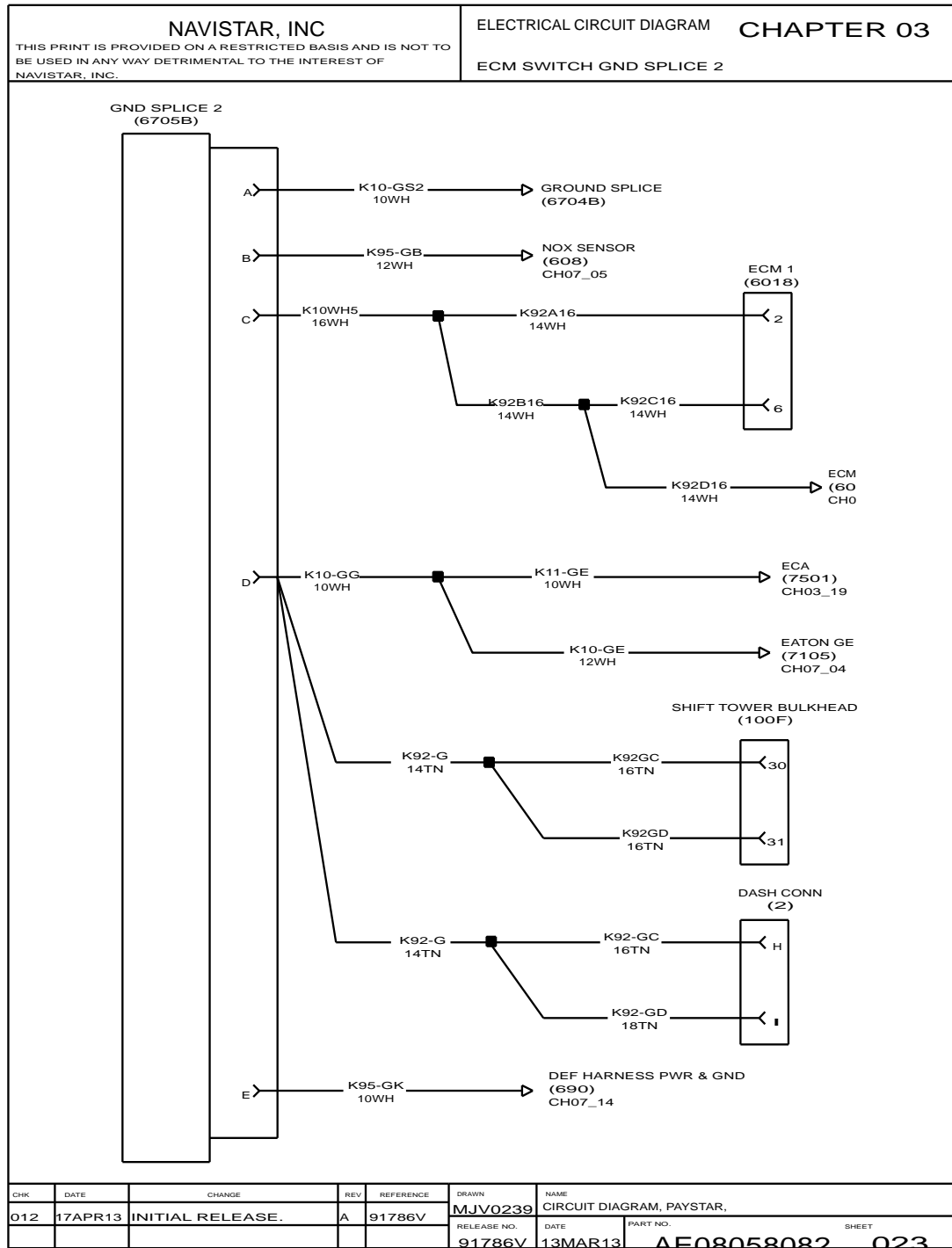


Figure 45 ECM Switch GND Splice 2

3.34. 250K J1939 CAB DATA LINK WITH 500K REGULATORY UPDATE, P. 24

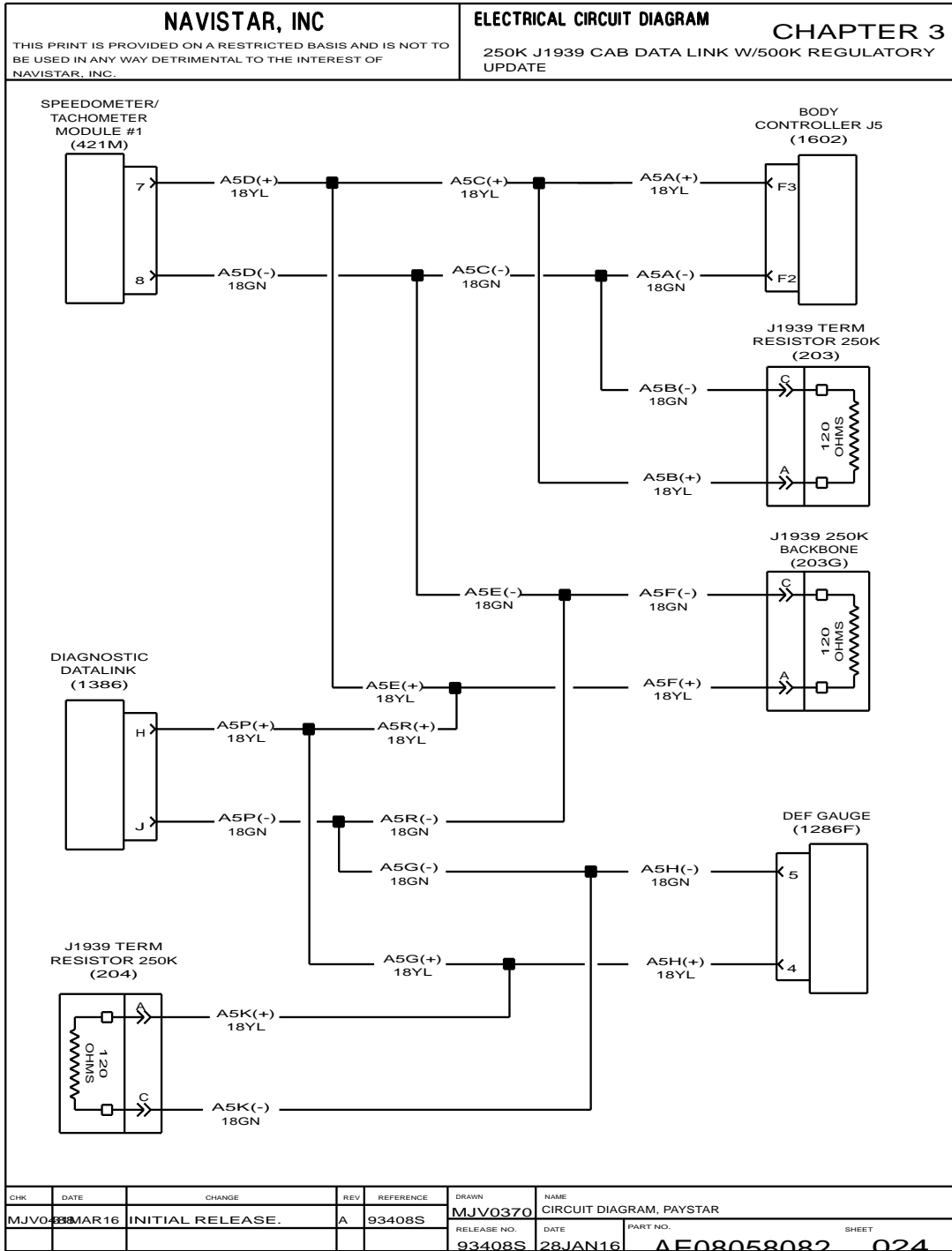


Figure 46 250K J1939 Cab Data Link with 500K Regulatory Update



3.35. J1939 DATA LINK WITH 500K BAUD RATE (CONT.), P. 25

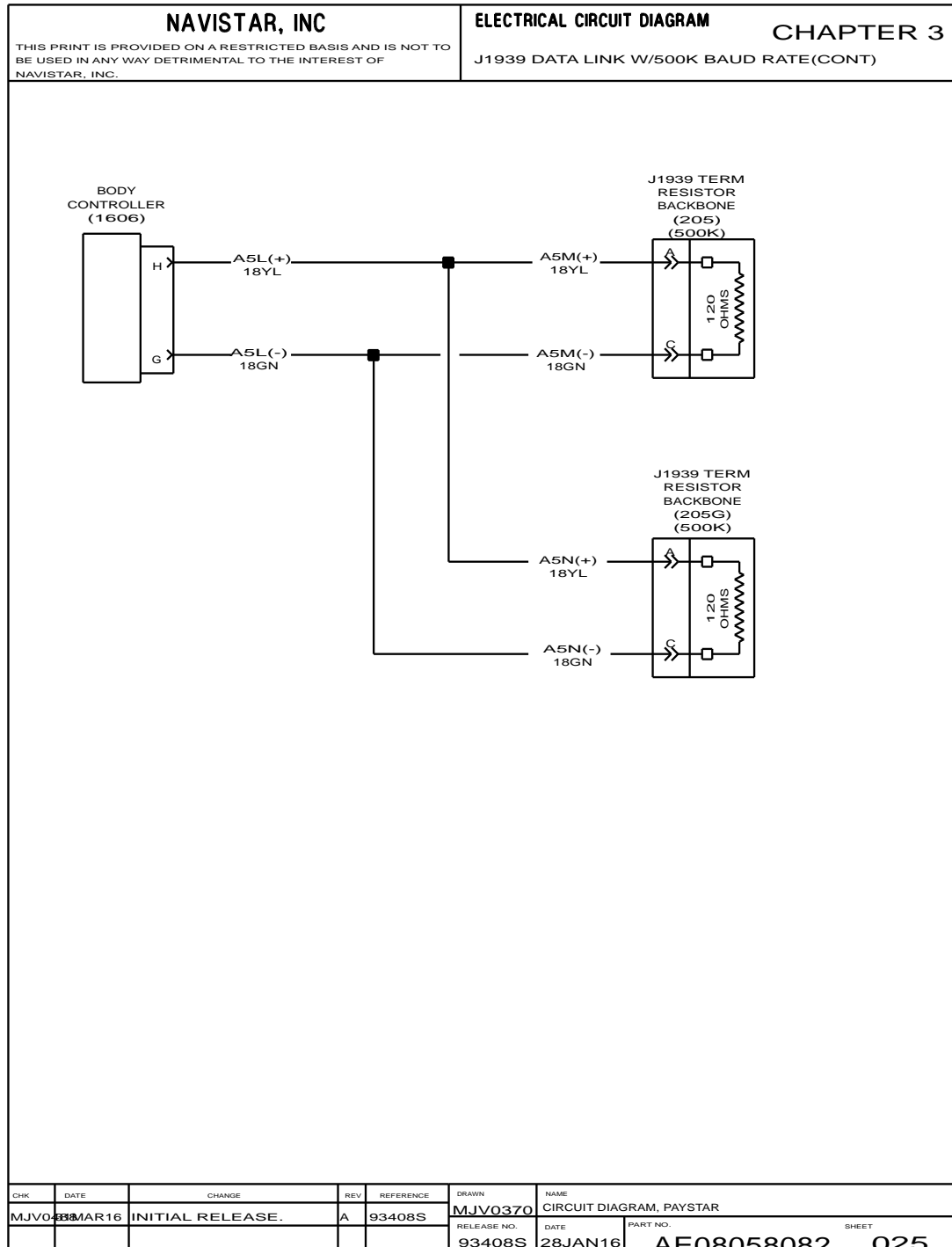


Figure 47 J1939 Data Link with 500K Baud Rate (Cont.)



4.2. ELECTRIC WINDOW – RIGHT AND LEFT, P. 2

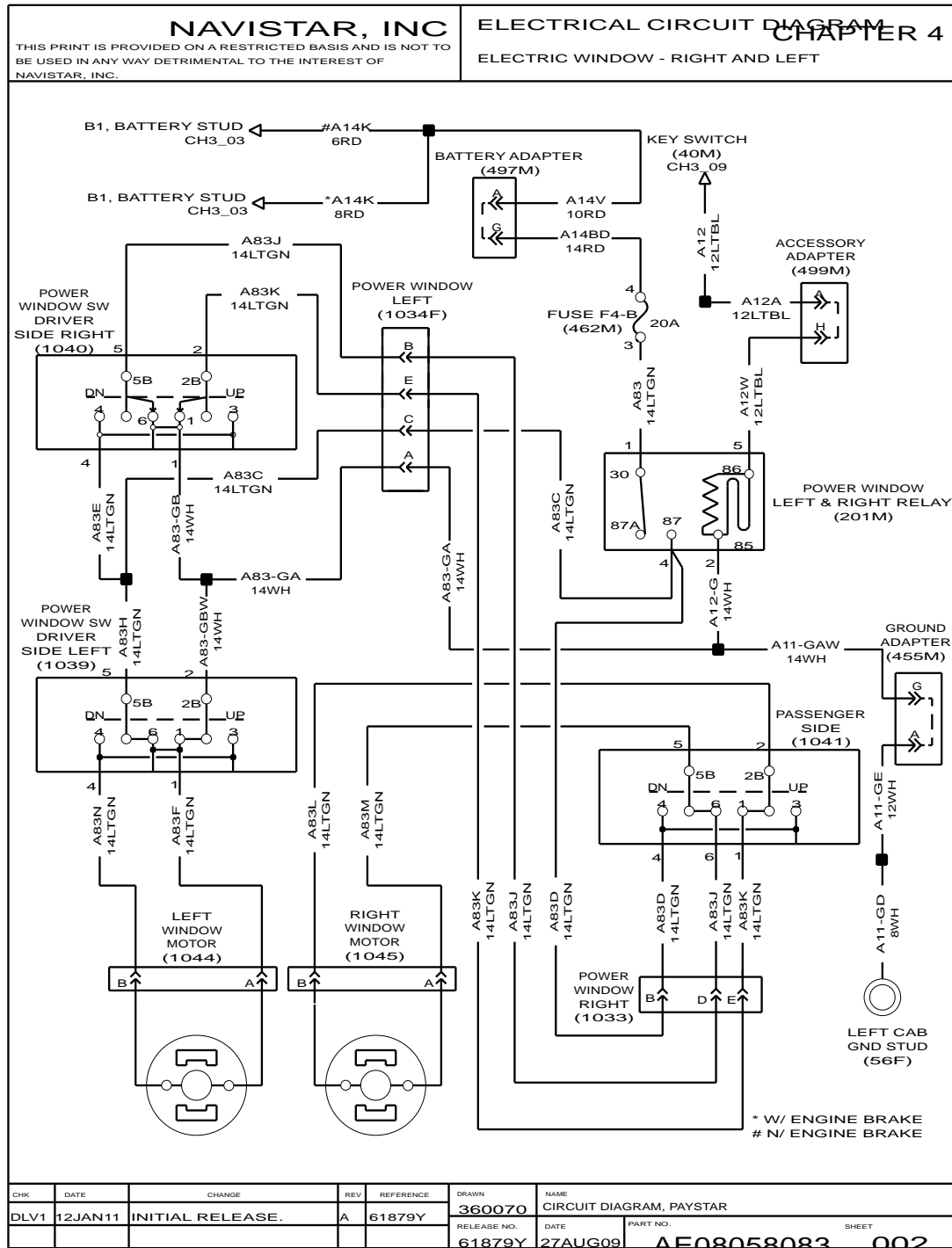


Figure 49 Electric Window – Right and Left

4.3. ELECTRIC WINDOW – RIGHT, P. 3

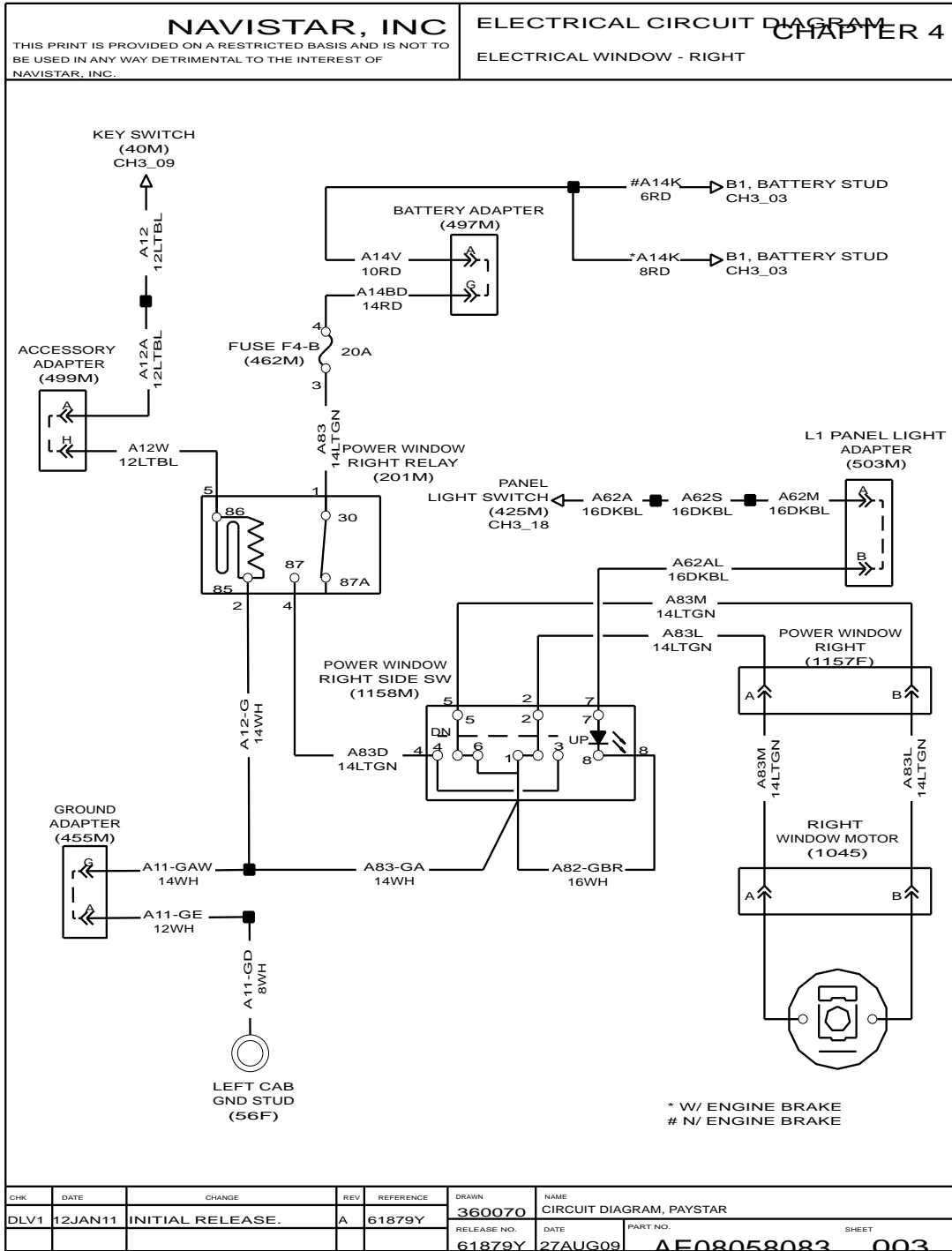


Figure 50 Electric Window – Right

4.4. DEFROSTER FAN(S), P. 4

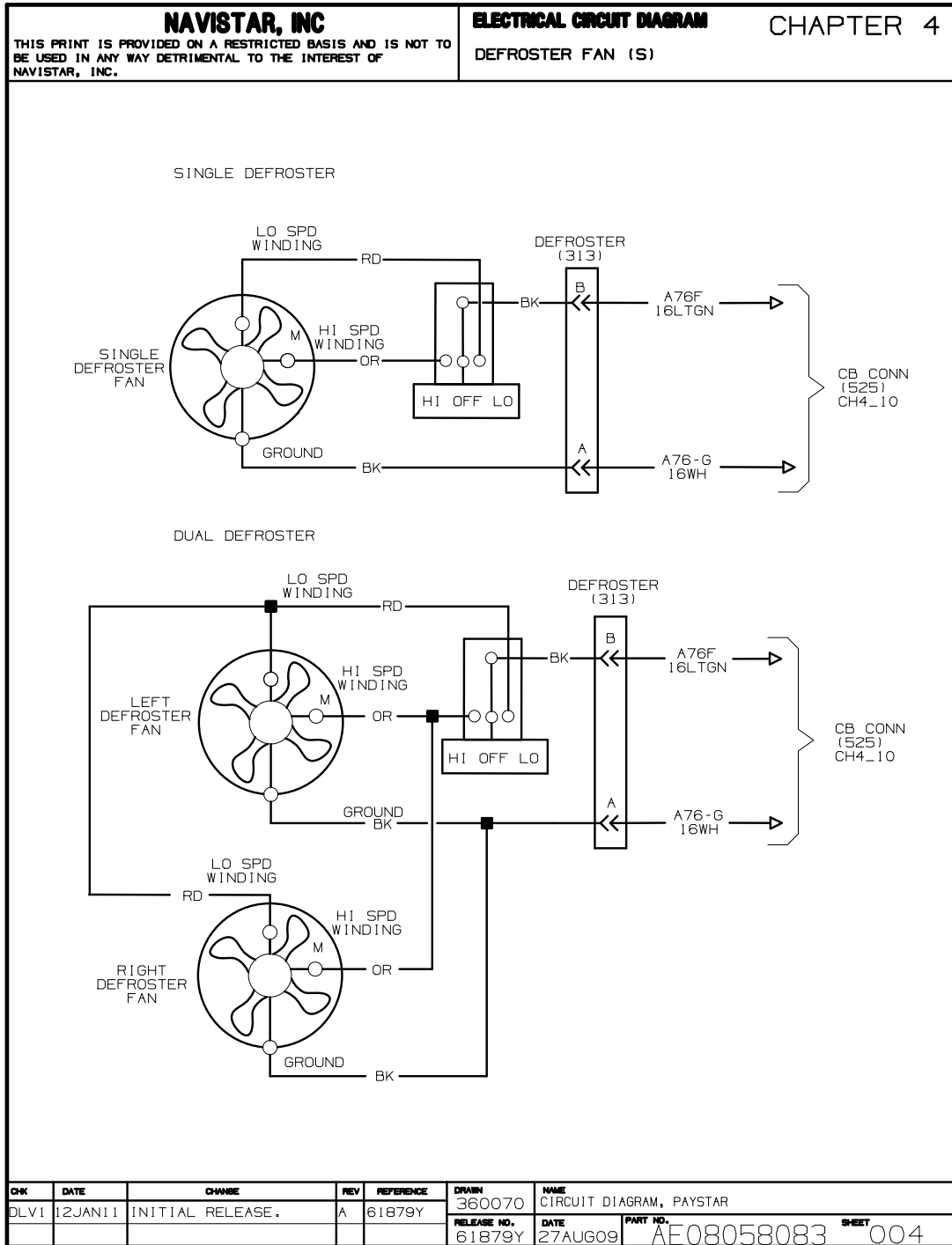


Figure 51 Defroster Fan(s)

4.5. HORN, P. 5

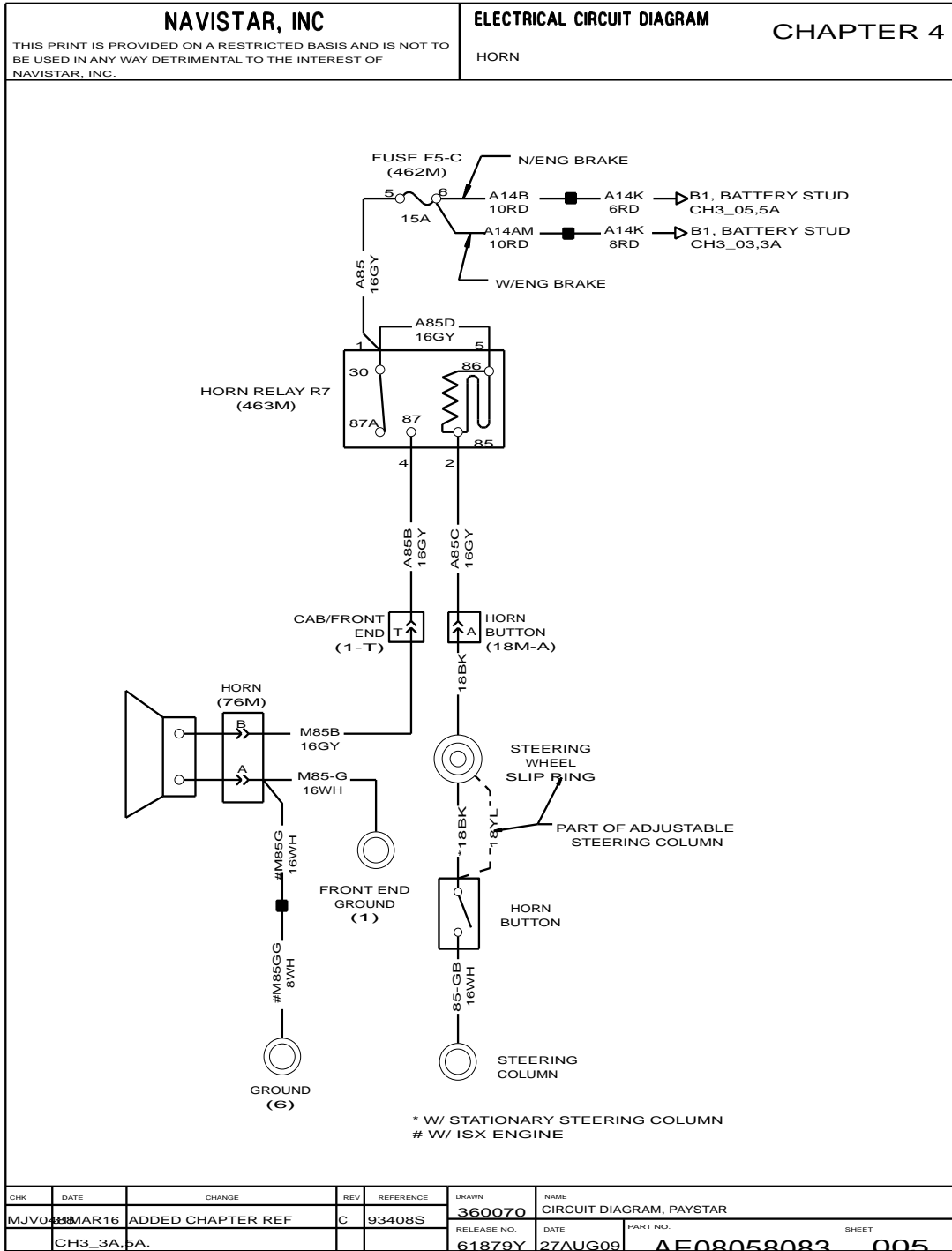


Figure 52 Horn

4.6. MIRROR LIGHTS AND HEATED MIRRORS, P. 6

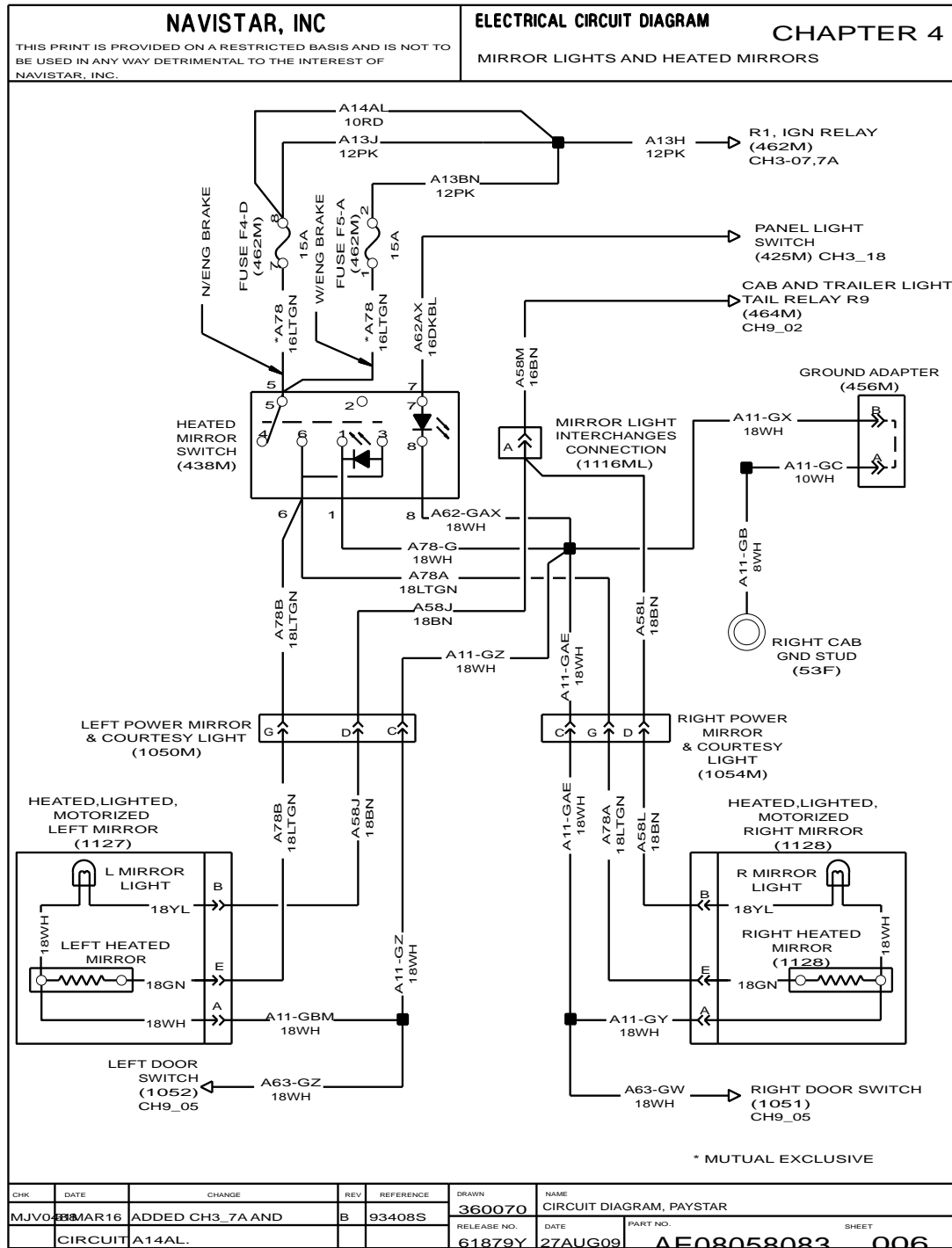


Figure 53 Mirror Lights and Heated Mirrors

4.7. LEFT AND RIGHT MOTORIZED MIRRORS, P. 7

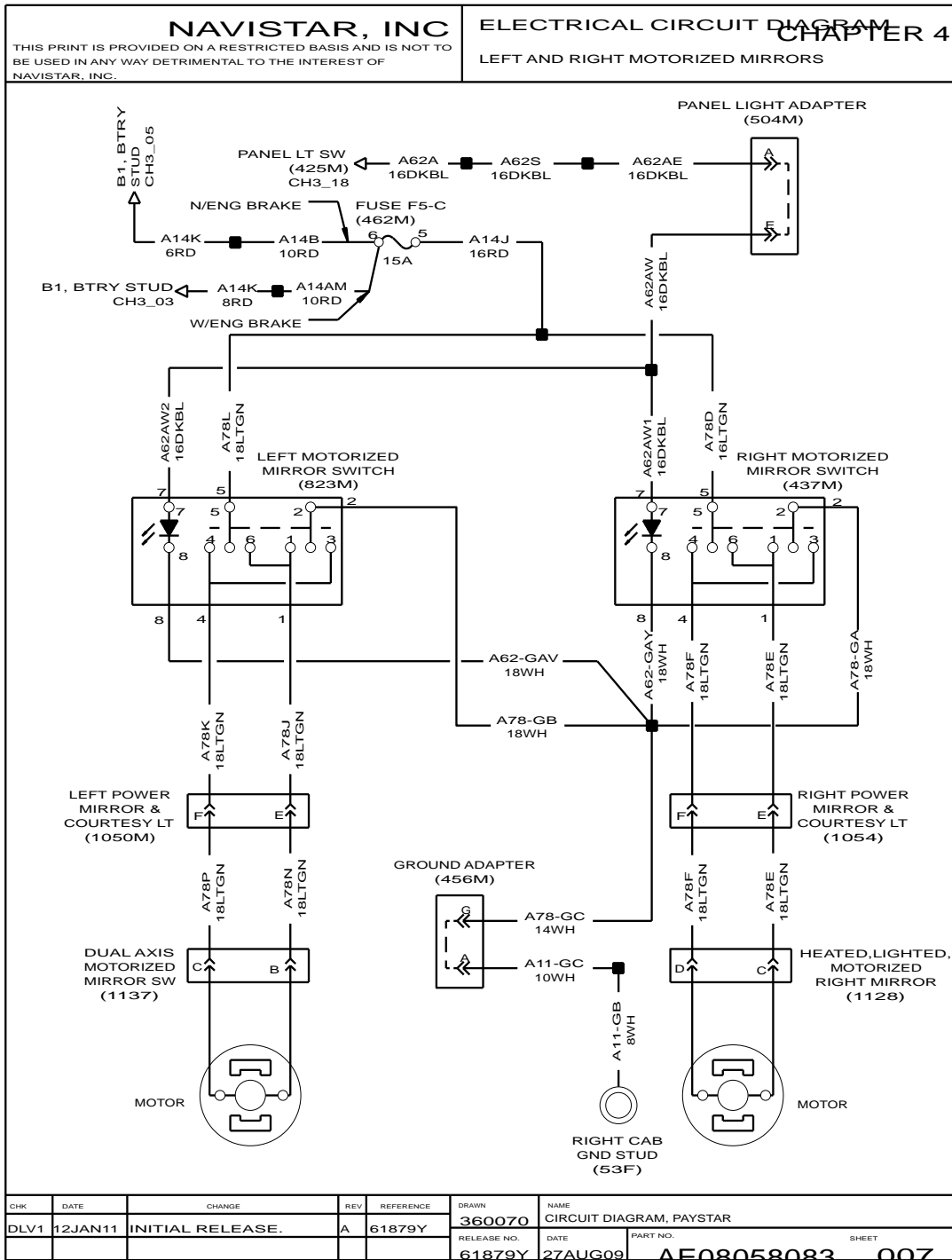


Figure 54 Left and Right Motorized Mirrors



4.8. DUAL AXIS MOTORIZED MIRRORS, P. 8

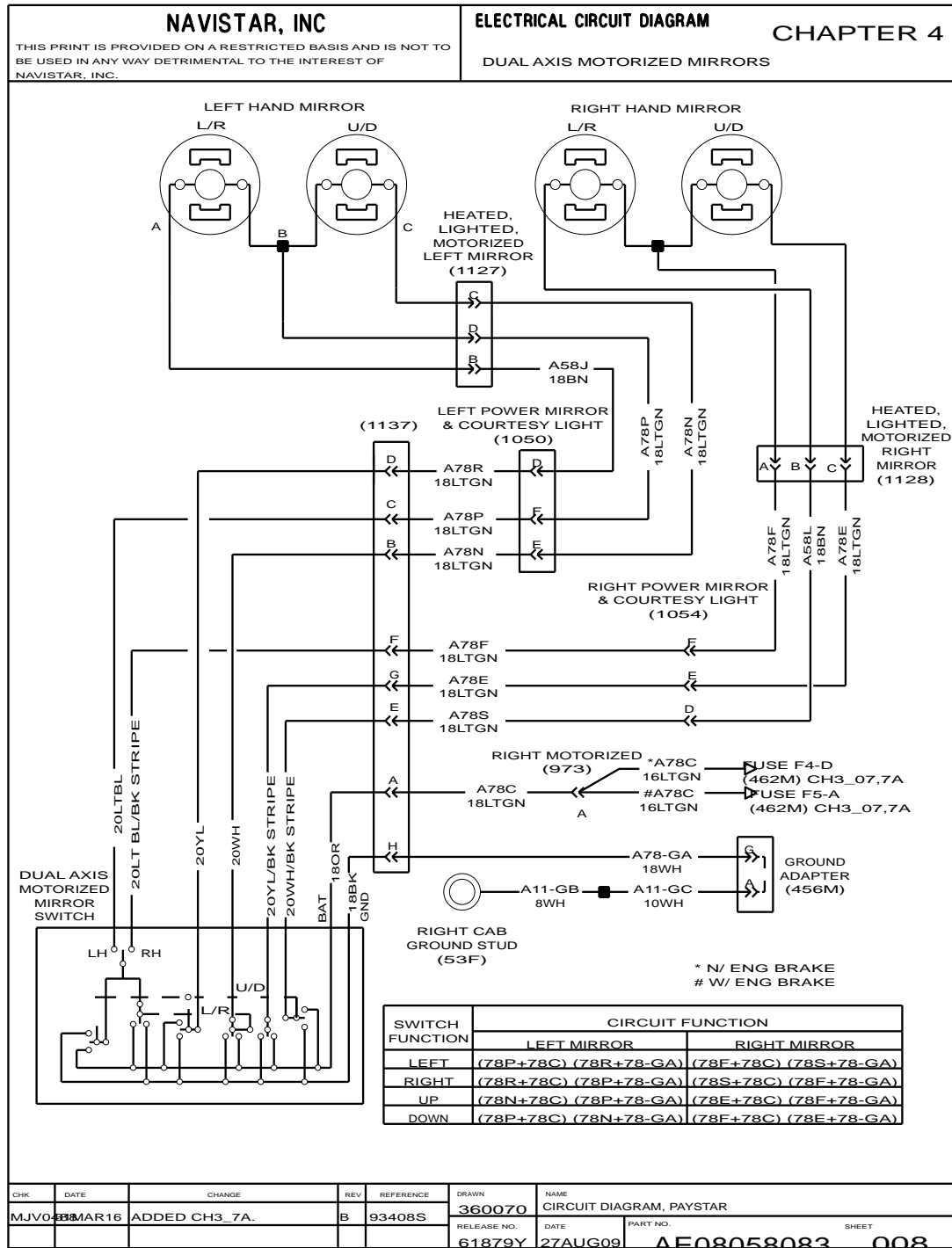


Figure 55 Dual Axis Motorized Mirrors

4.9. POWER SOURCE (CB), P. 9

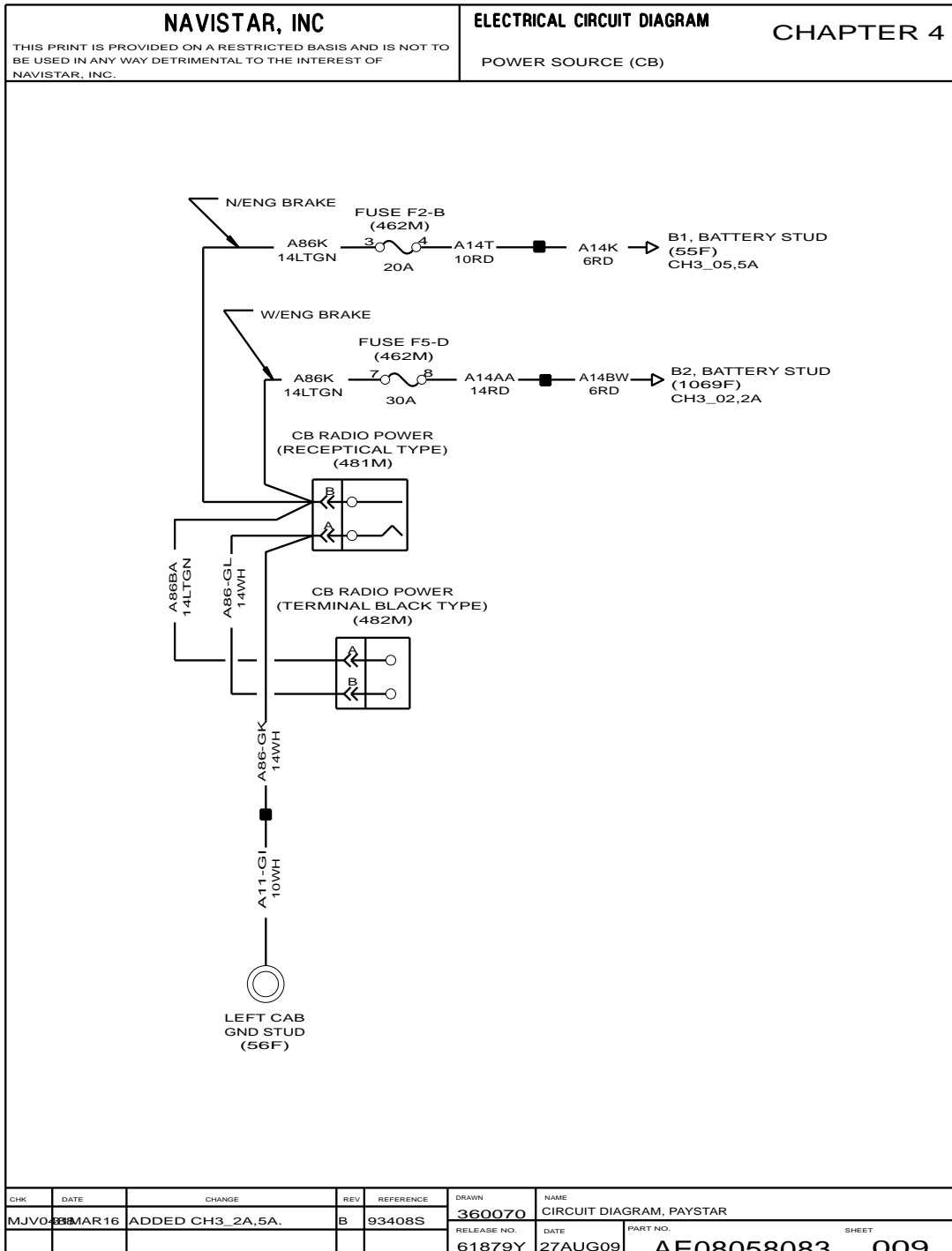


Figure 56 Power Source (CB)

4.10. RADIO - CB ACCOMMODATION PACKAGE, P. 10

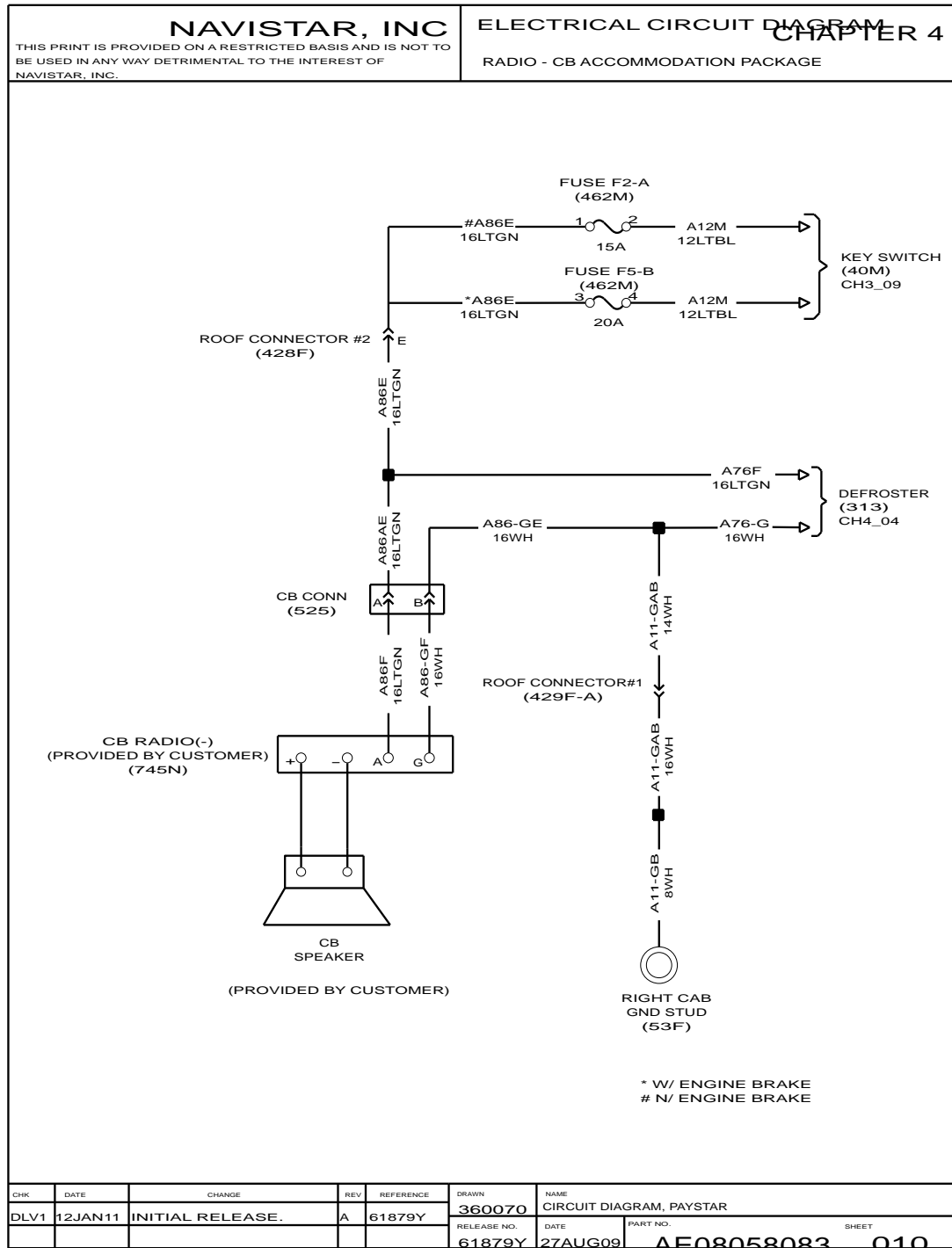


Figure 57 Radio - CB Accommodation Package

4.11. RADIO – CAB SPEAKERS, P. 11

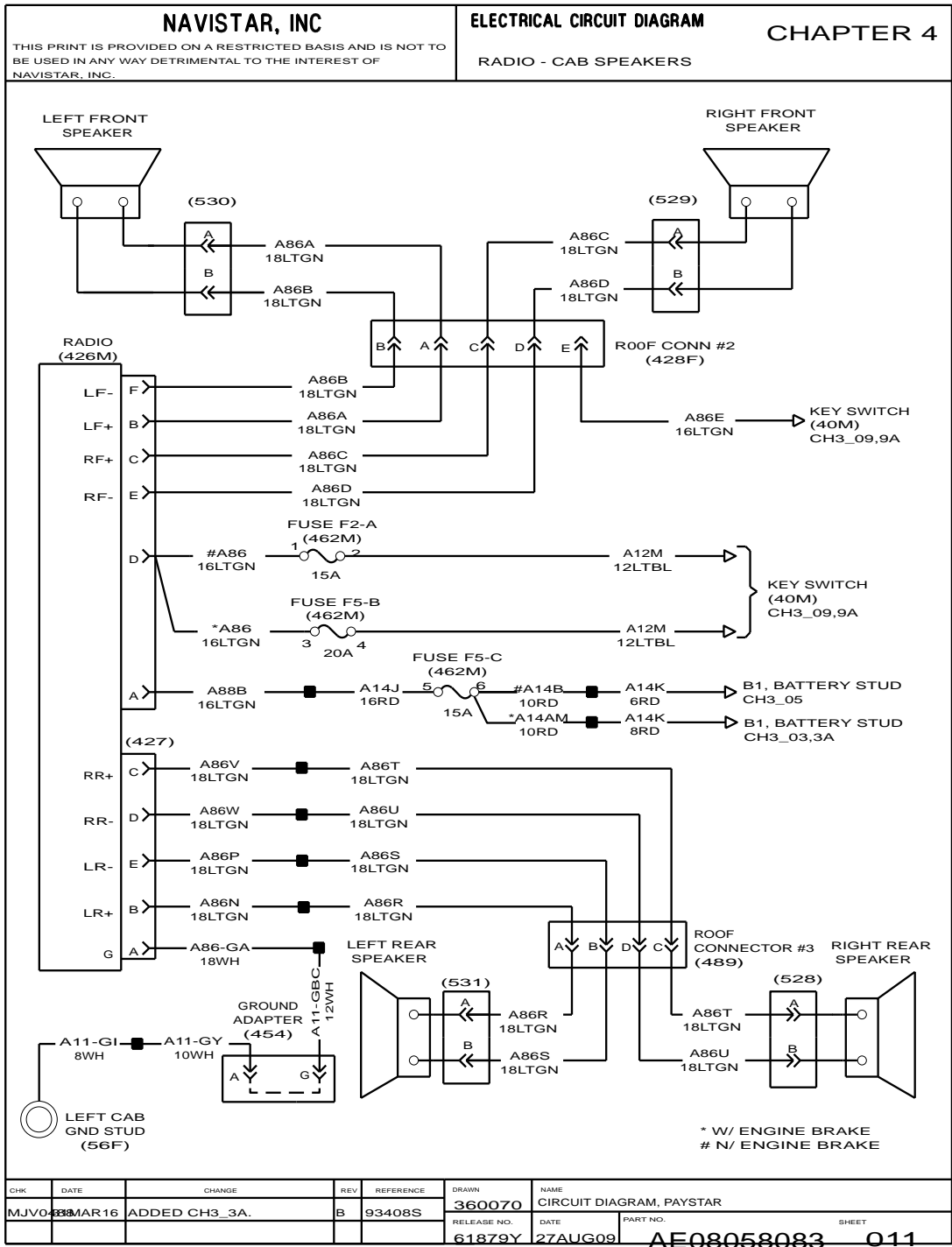


Figure 58 Radio – Cab Speakers

4.12. ELECTRIC LOCK – RIGHT AND LEFT, P. 12

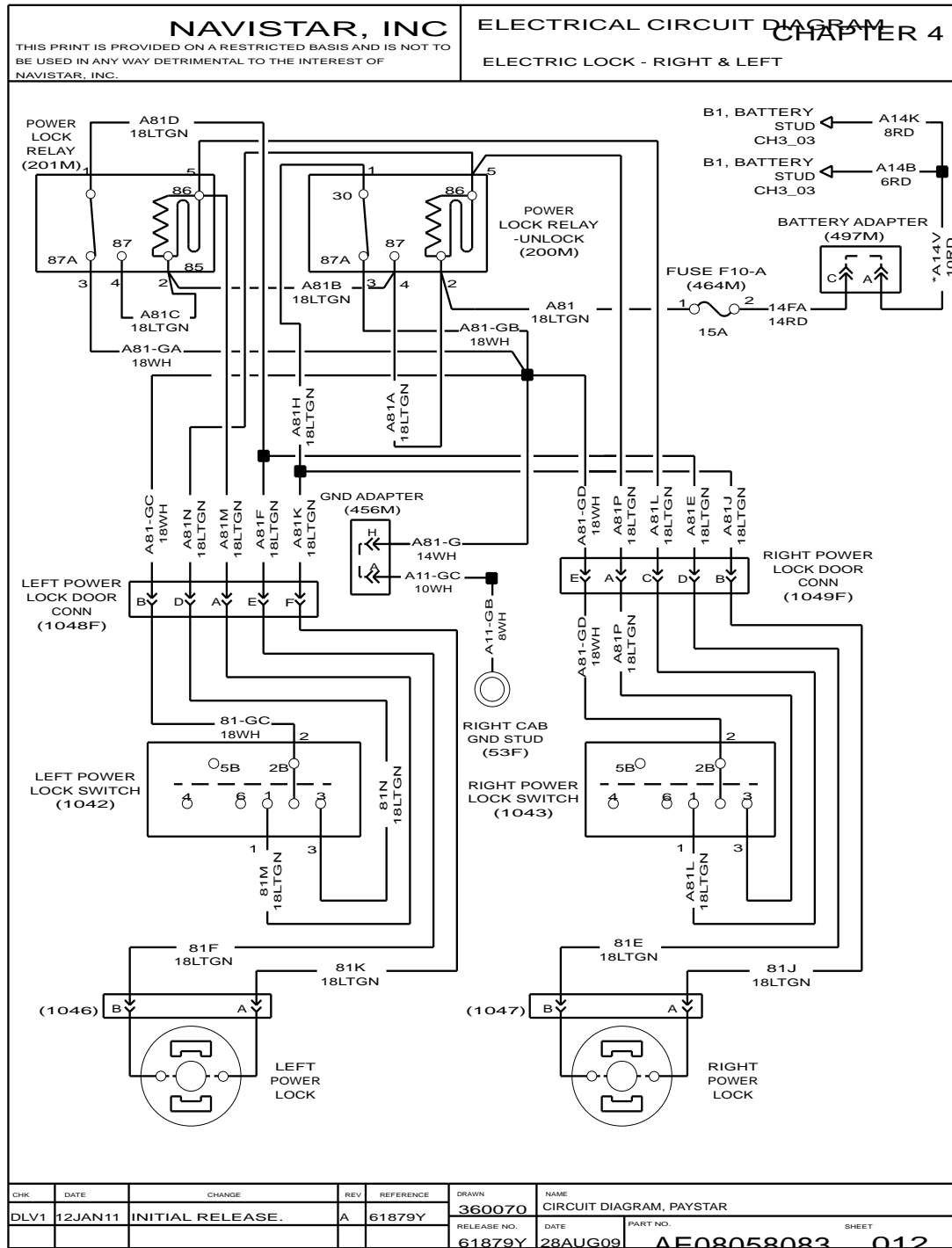


Figure 59 Electric Lock – Right and Left

4.13. TEMPERATURE / COMPASS DISPLAY, P. 13

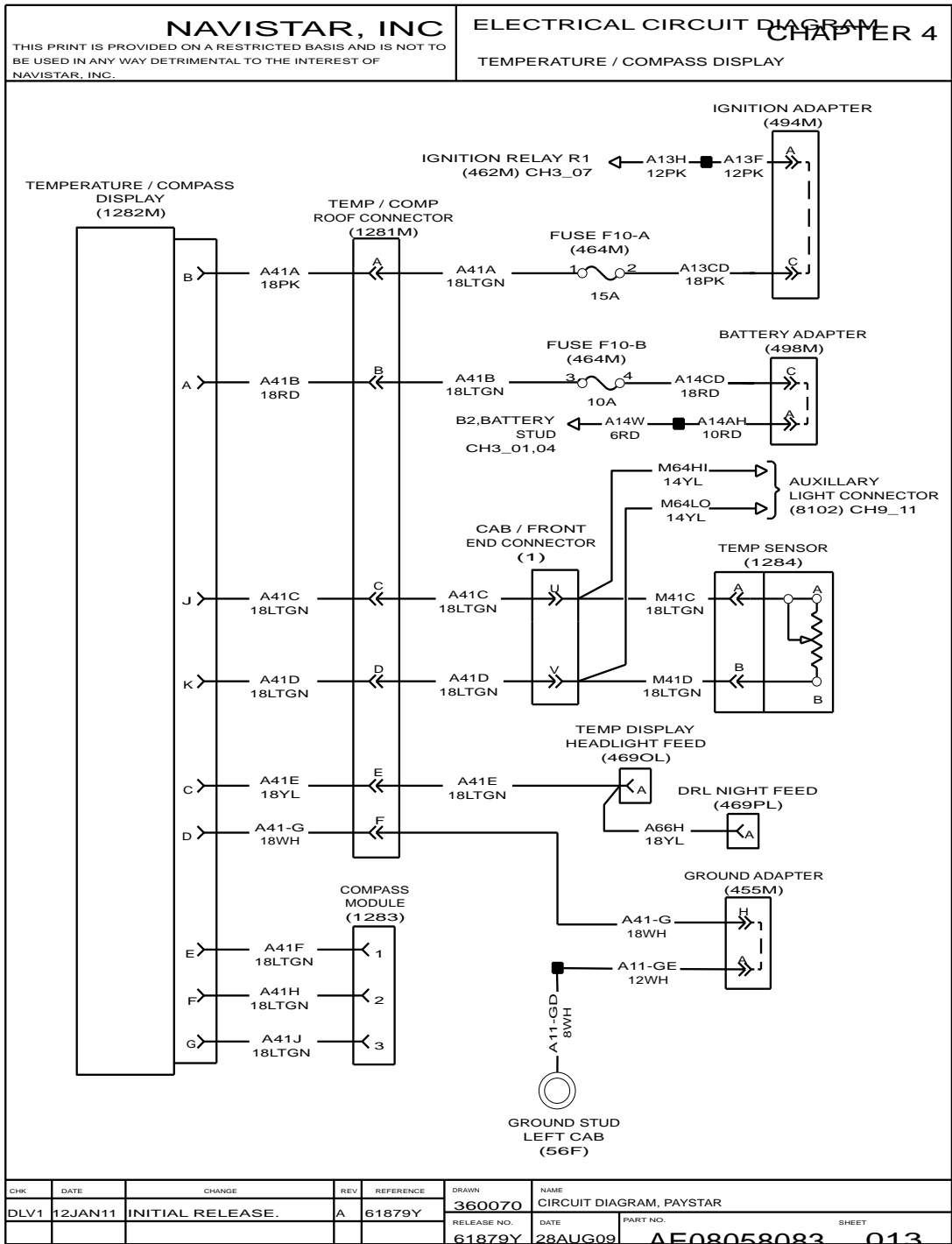


Figure 60 Temperature / Compass Display

4.14. ROAD RELAY IV, P. 14

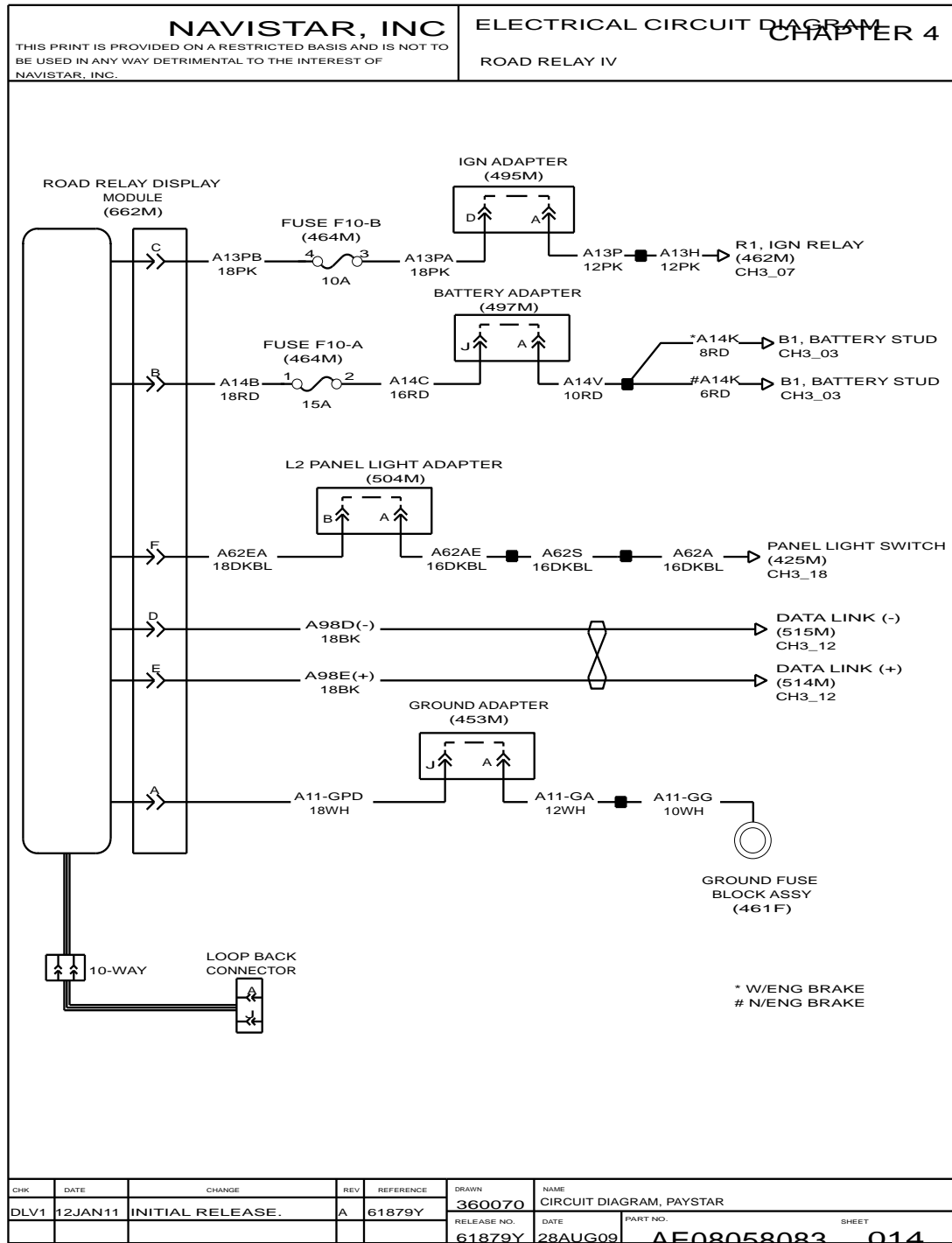


Figure 61 Road Relay IV

4.15. HEATED SEAT – DRIVER, P. 15

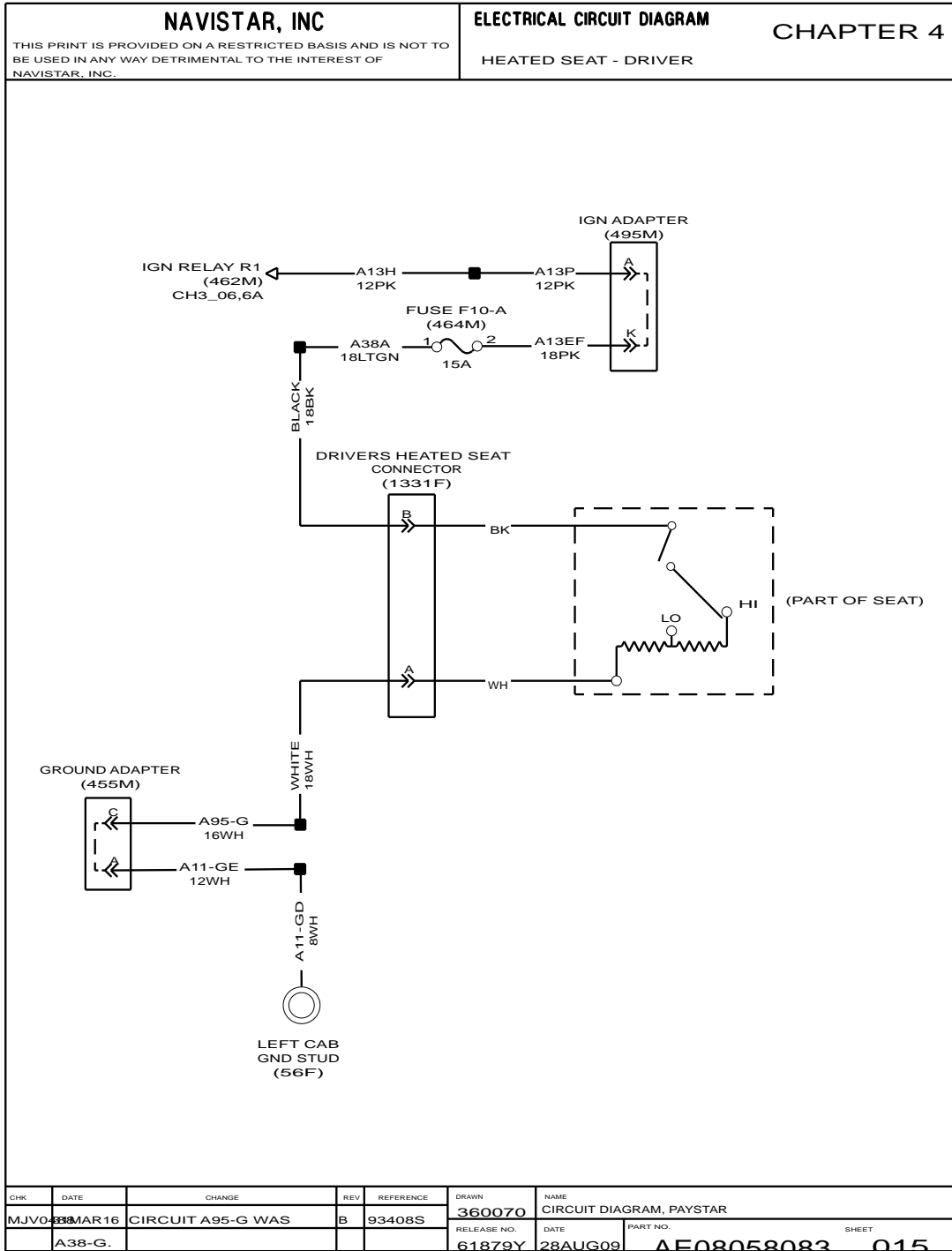


Figure 62 Heated Seat – Driver



4.16. HEATED SEAT – PASSENGER, P. 16

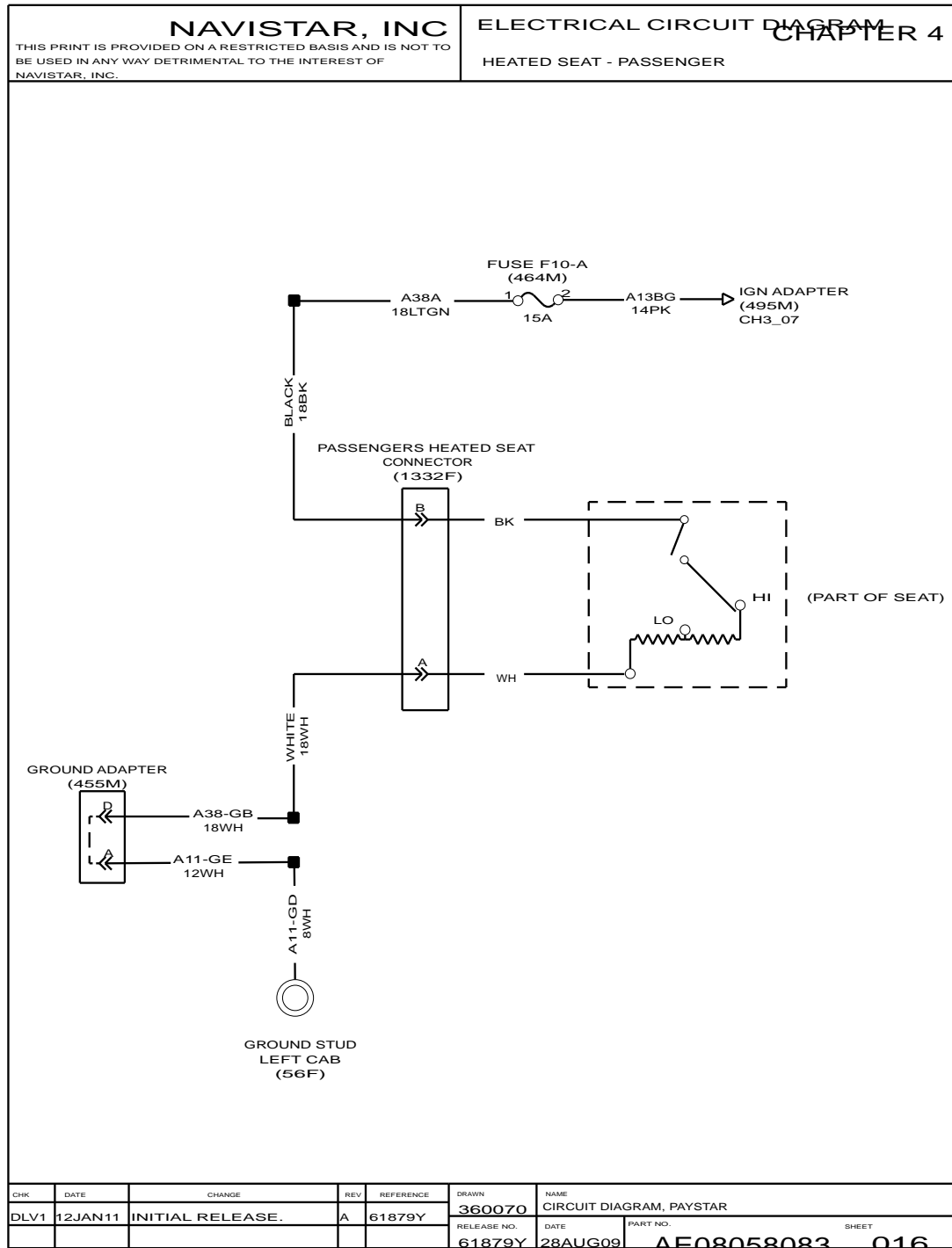


Figure 63 Heated Seat – Passenger

4.17. ELECTRIC WINDSHIELD WIPER WITH INTERMITTENT WIPE AND WASH, P. 17

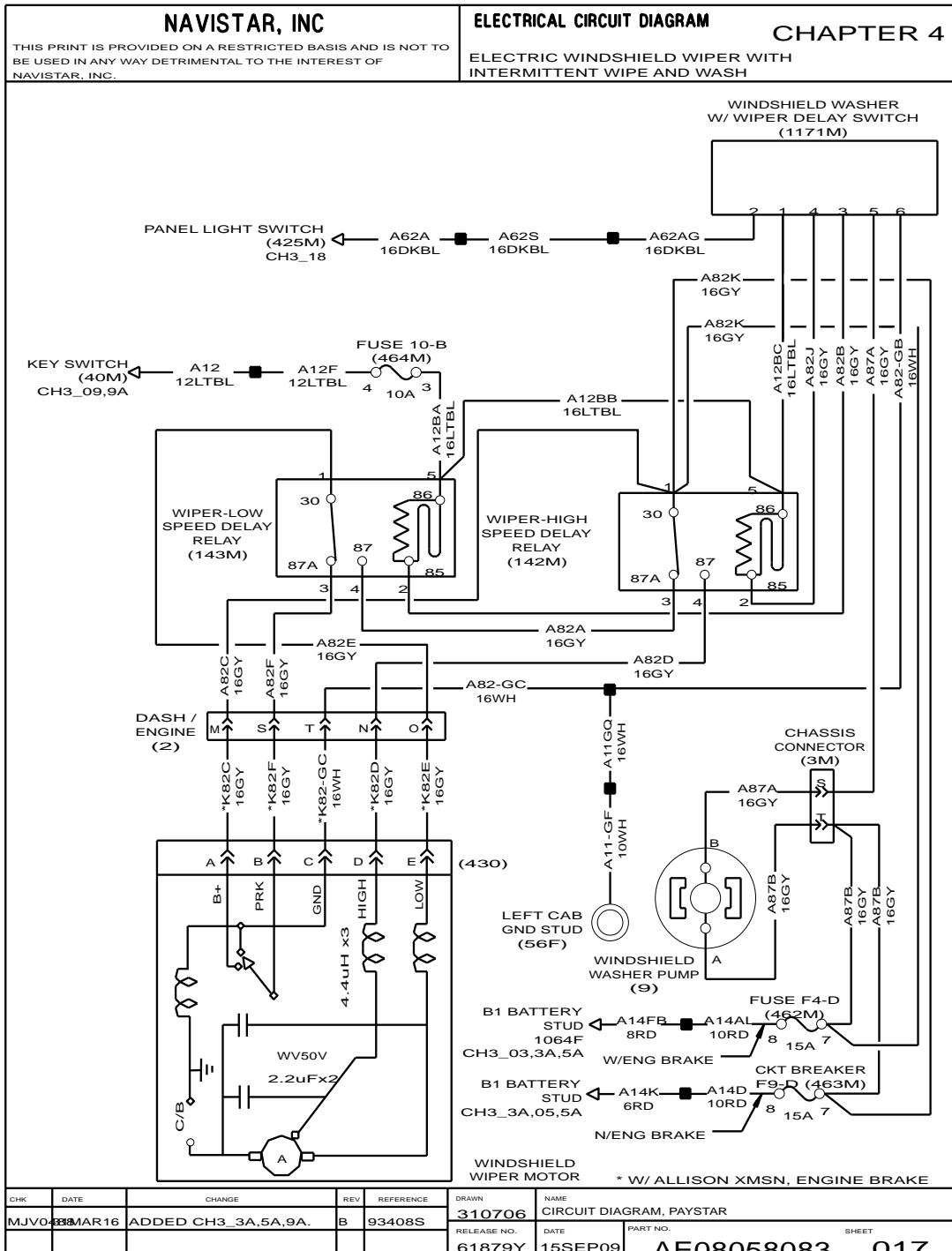


Figure 64 Electric Windshield Wiper with Intermittent Wipe and Wash

4.18. DEF GAUGE, P. 18

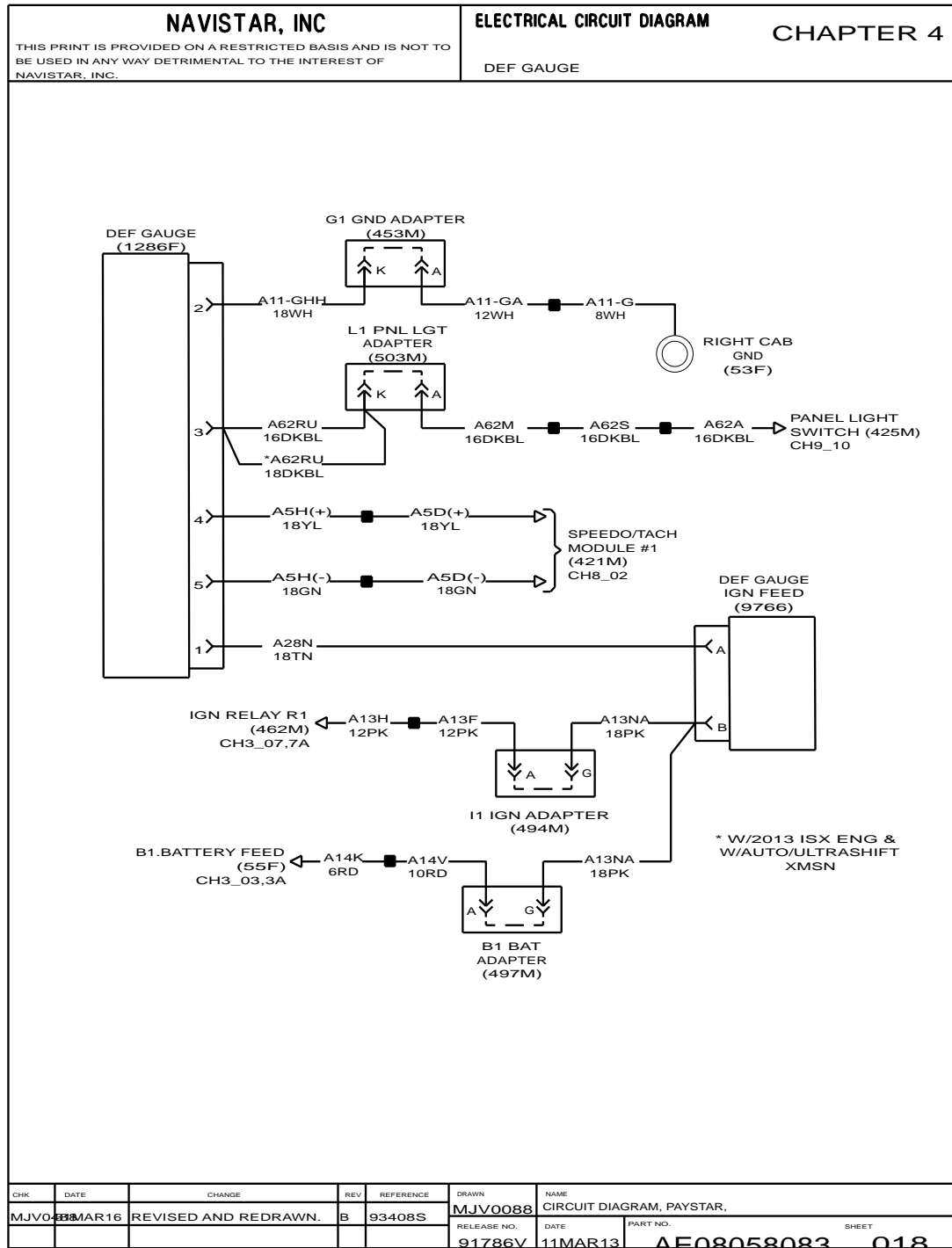


Figure 65 DEF Gauge

4.19. HEWITT MOTION SENSOR, P. 19

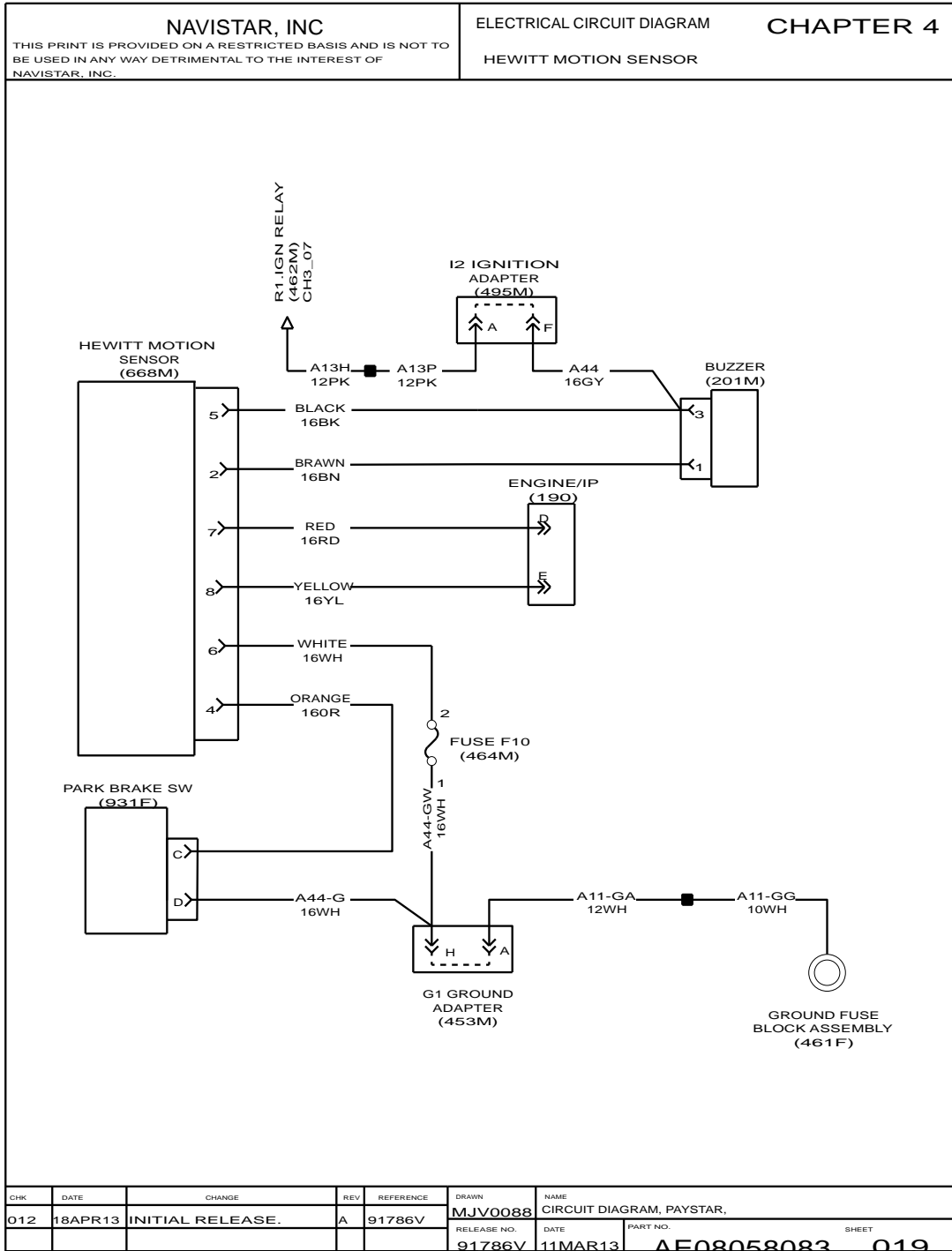


Figure 66 Hewitt Motion Sensor

## CHARGING AND CRANKING (CHAPTER 5)

### 5.1. STARTER INTERLOCK WITH IBB ENGINES, P. 1

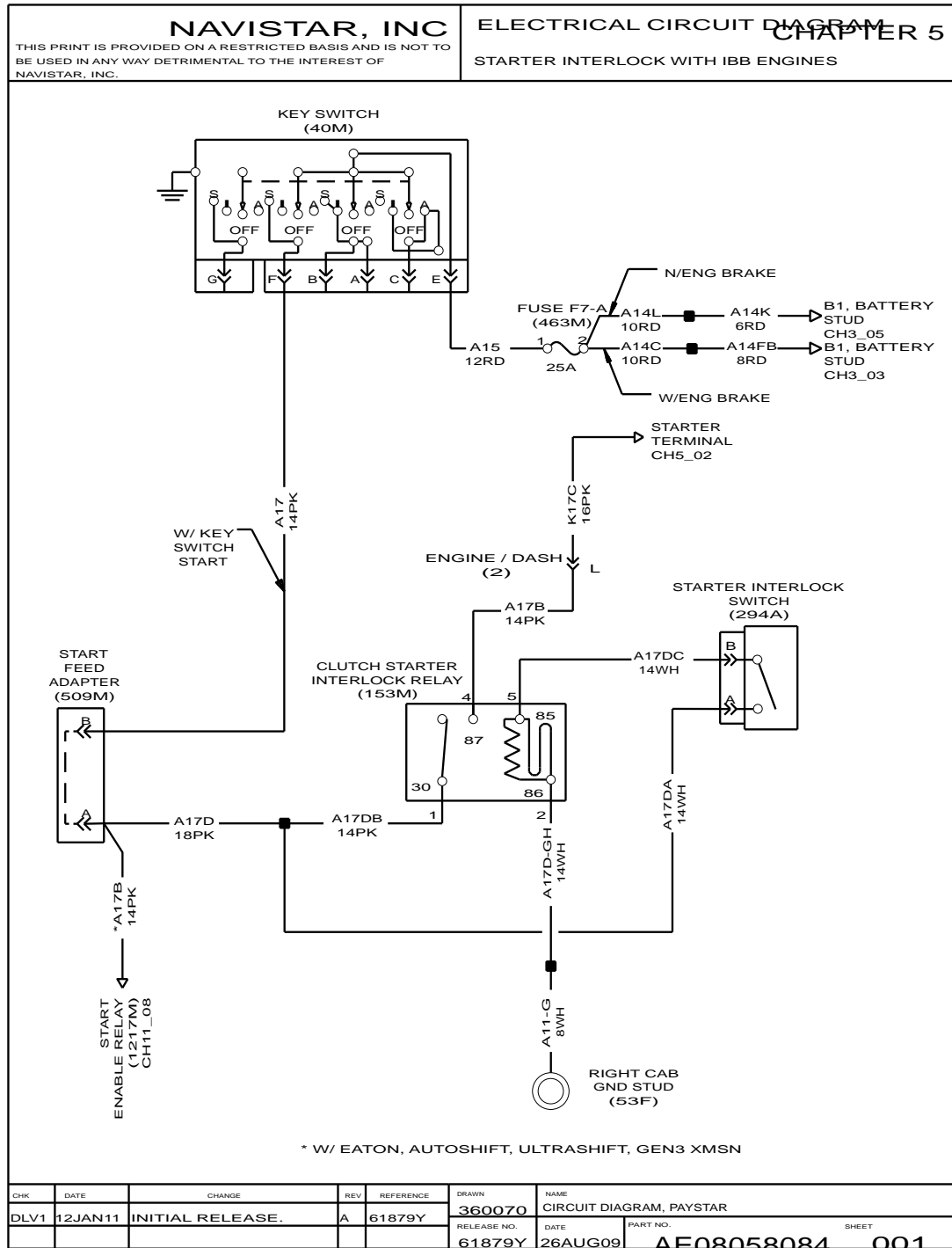


Figure 67 Starter Interlock with IBB Engines

5.2. STARTER INTERLOCK WITH IBB ENGINES WITH 500K BAUD RATE, P. 1A

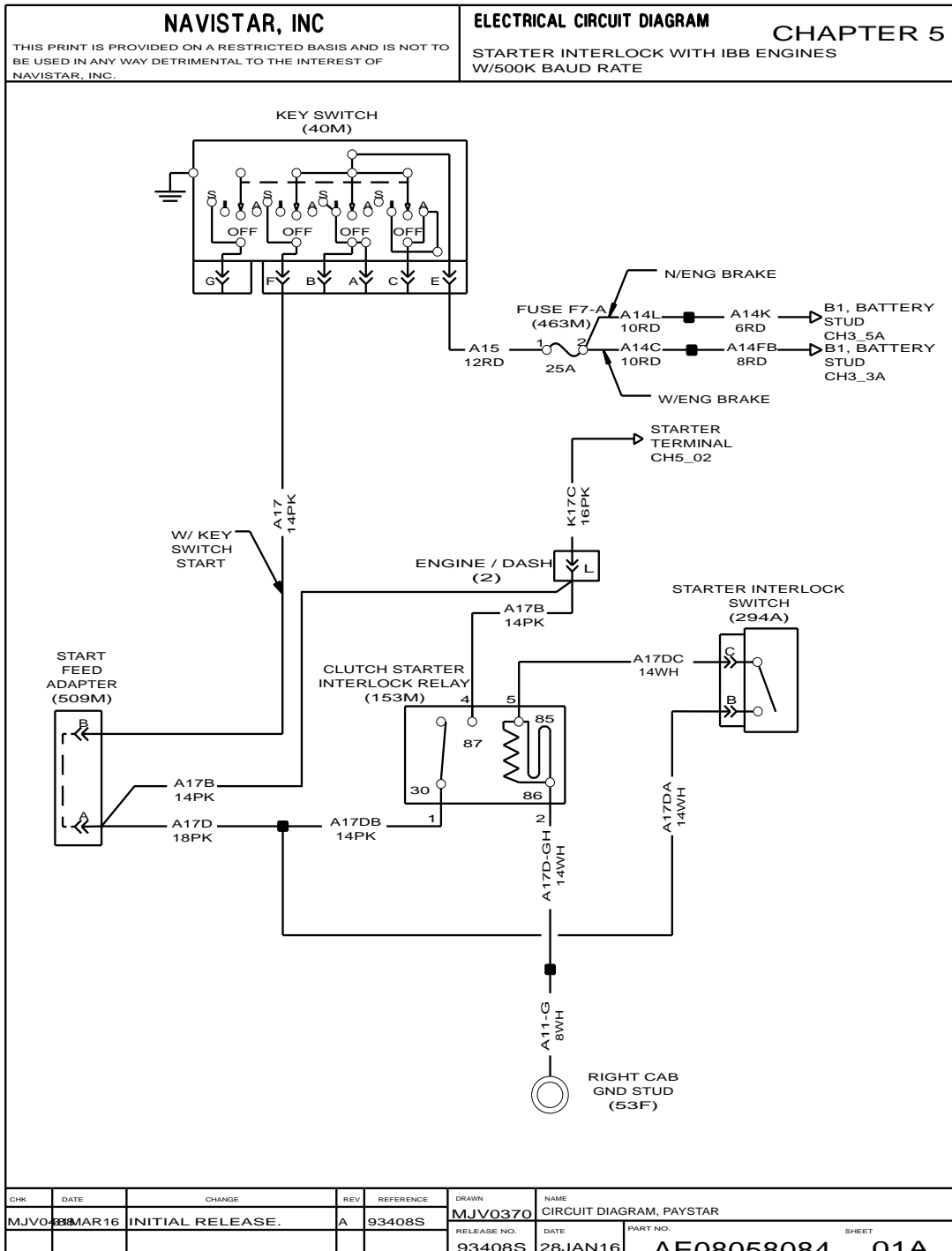


Figure 68 Starter Interlock with IBB Engines with 500K Baud Rate

5.3. STARTER INTERLOCK WITH IBB ENGINES, P. 2

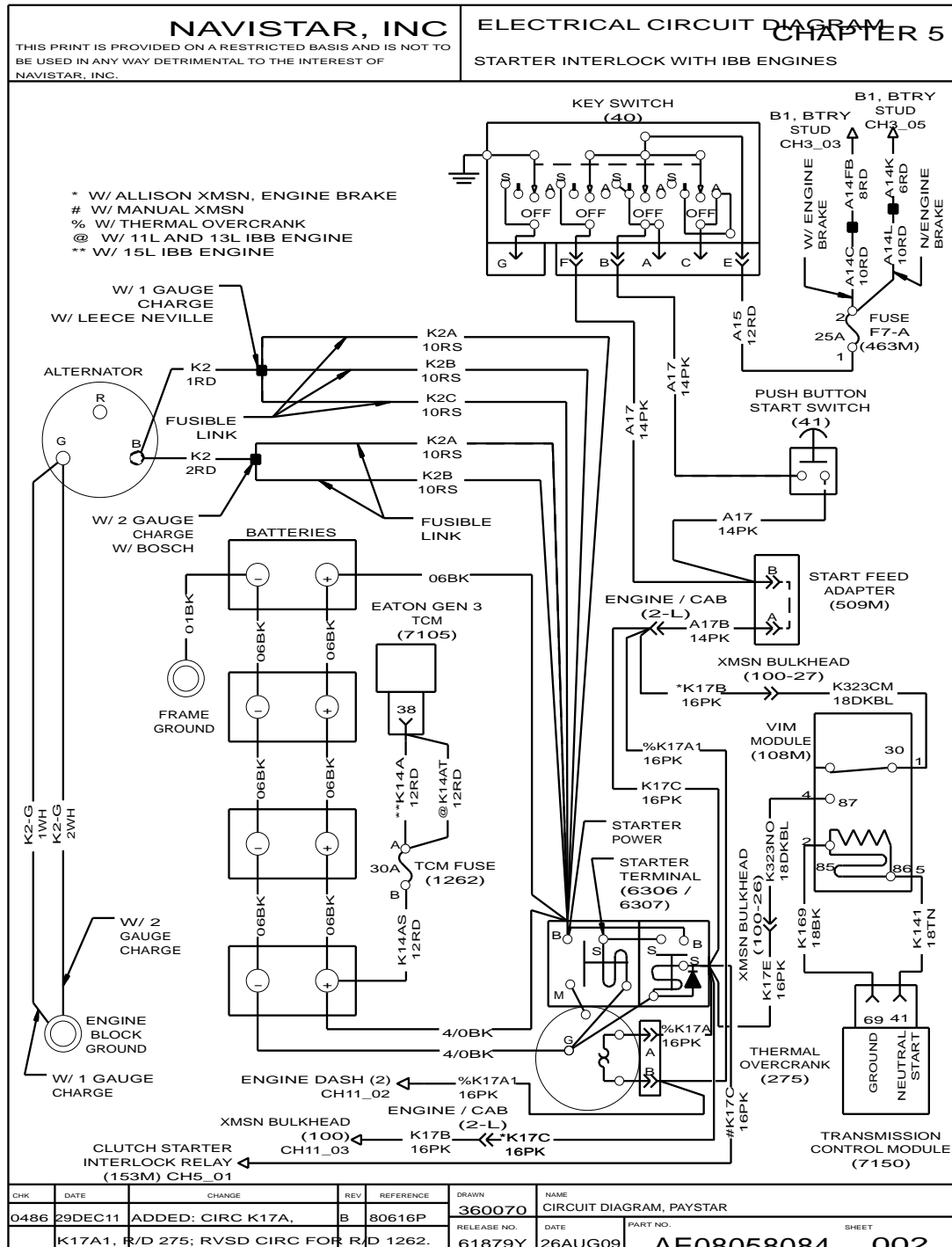


Figure 69 Starter Interlock with IBB Engines

5.4. STARTER INTERLOCK WITH IBB ENGINES, P. 2A

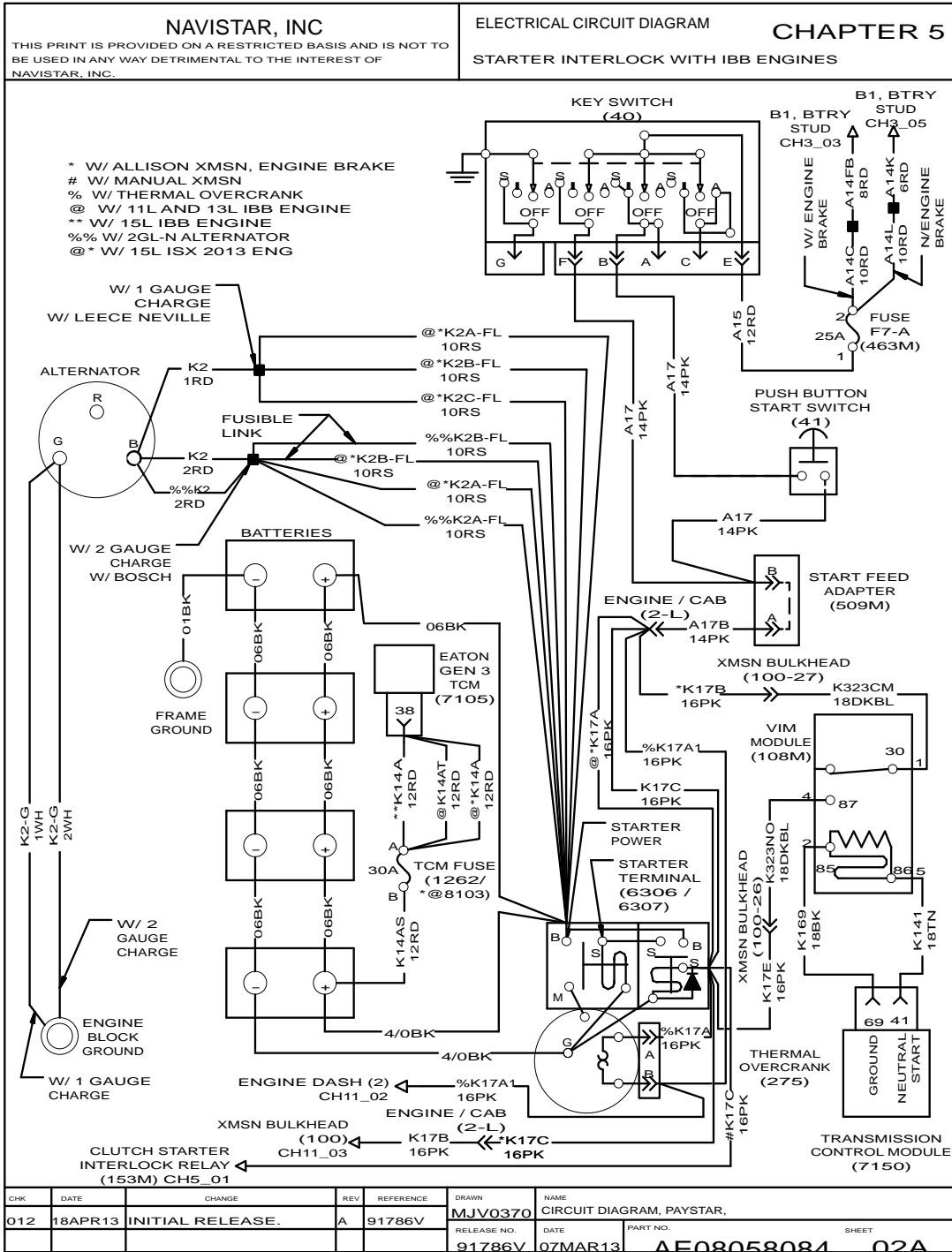


Figure 70 Starter Interlock with IBB Engines



## FANS WIRING (CHAPTER 6)

### 6.1. FAN WIRING – IBB ENGINE, P. 1

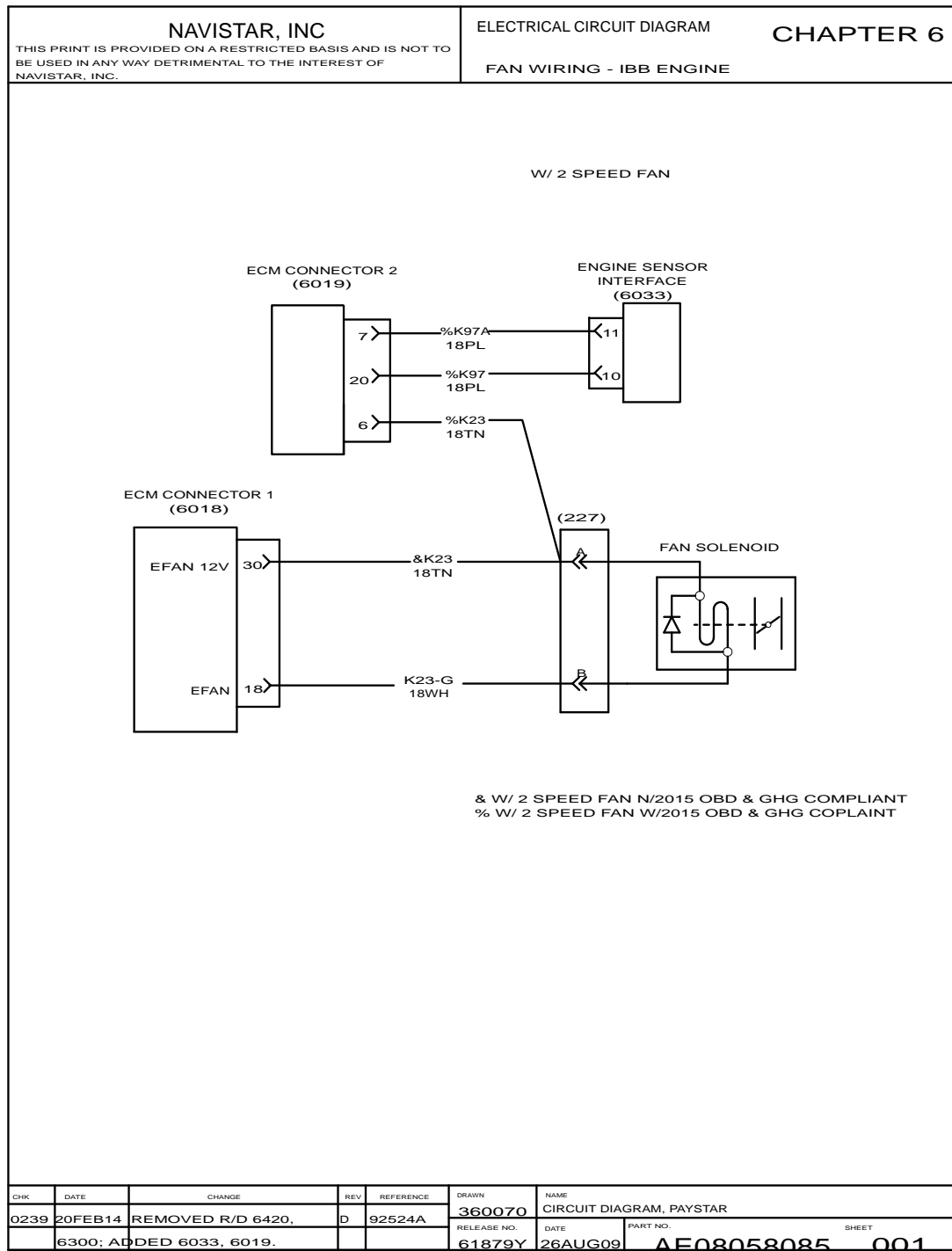


Figure 71 Fan Wiring – IBB Engine

6.2. FAN WIRING – IBB ENGINE (CONT.), P. 1A

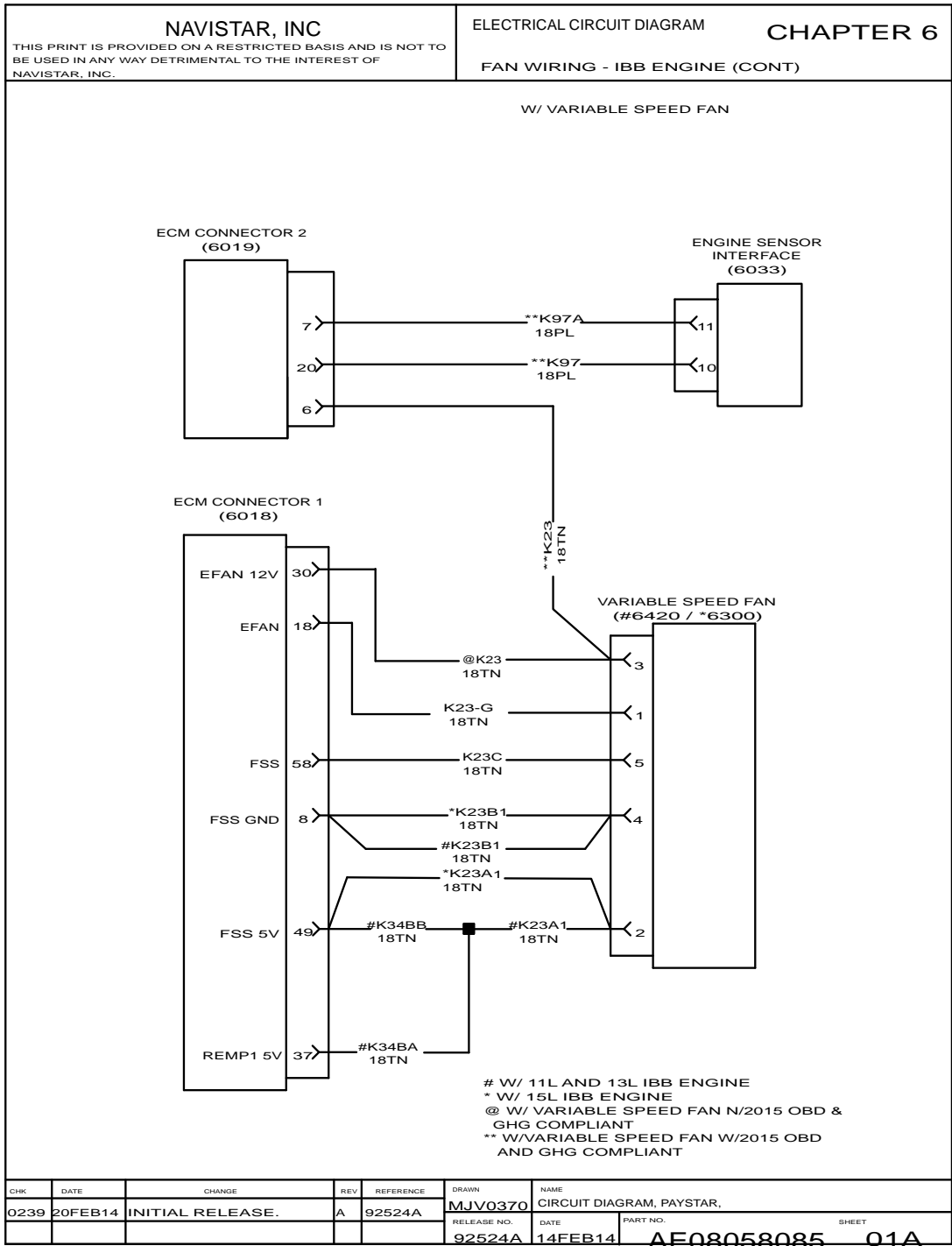


Figure 72 Fan Wiring – IBB Engine (Cont.)

6.3. FAN WIRING – IBB ENGINE (CONT.), P. 2

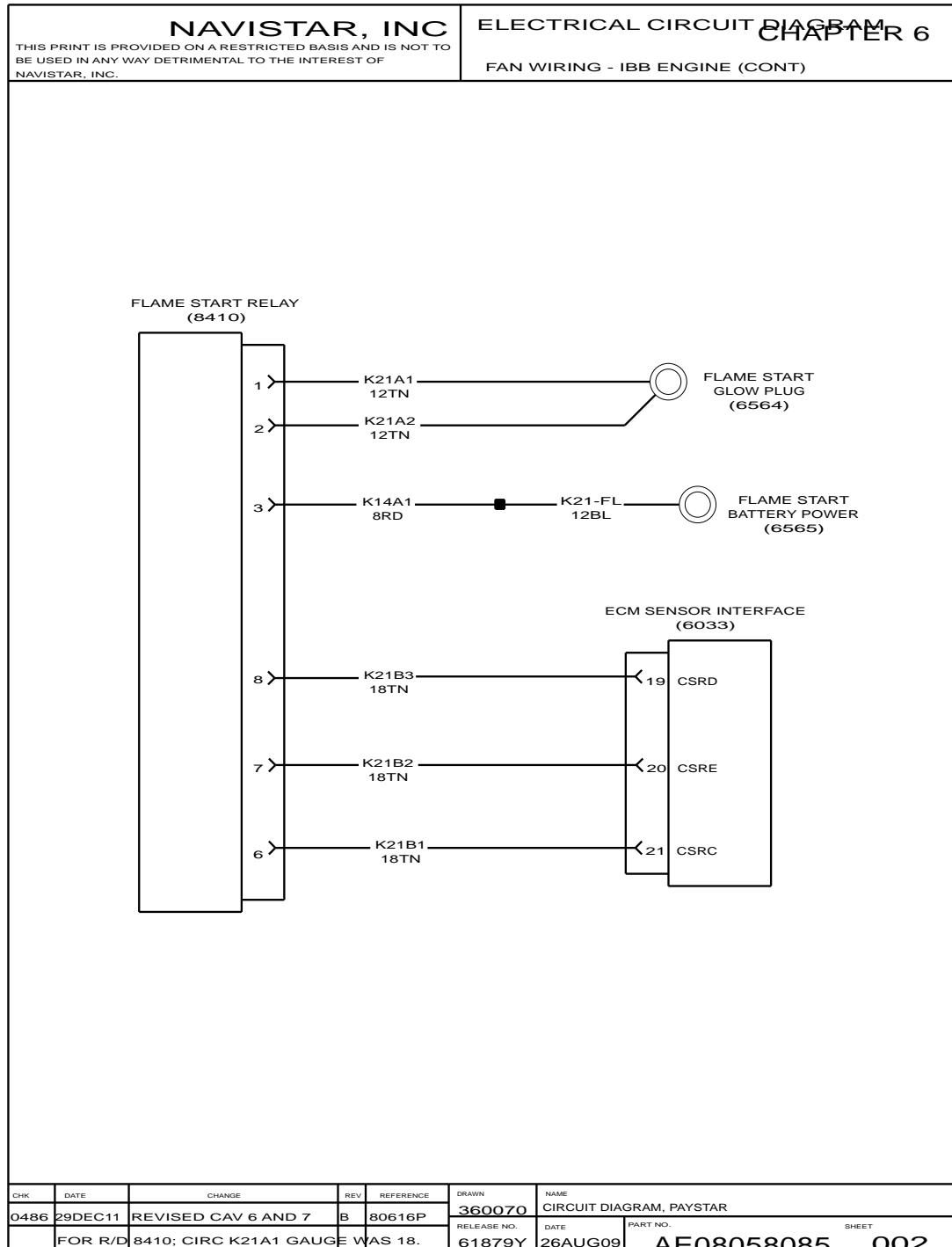


Figure 73 Fan Wiring – IBB Engine (Cont.)

# ENGINE SYSTEMS (CHAPTER 7)

## 7.1. ELECTRONIC ENGINE CONTROLS (2010 IBB ENGINE), P. 1

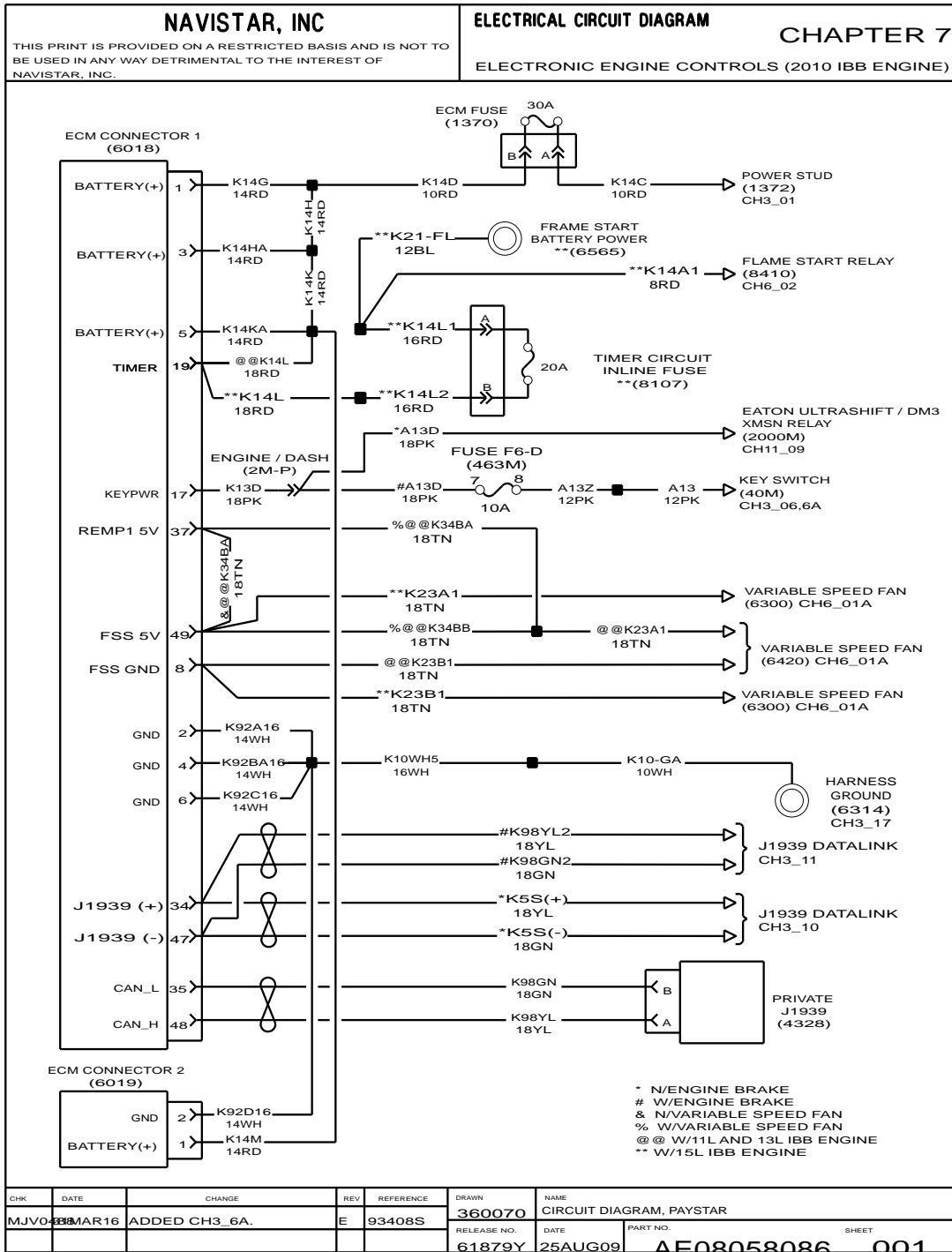


Figure 74 Electronic Engine Controls (2010 IBB Engine)

7.2. ELECTRONIC ENGINE CONTROLS (2010 IBB ENGINE) (CONT.), P. 2

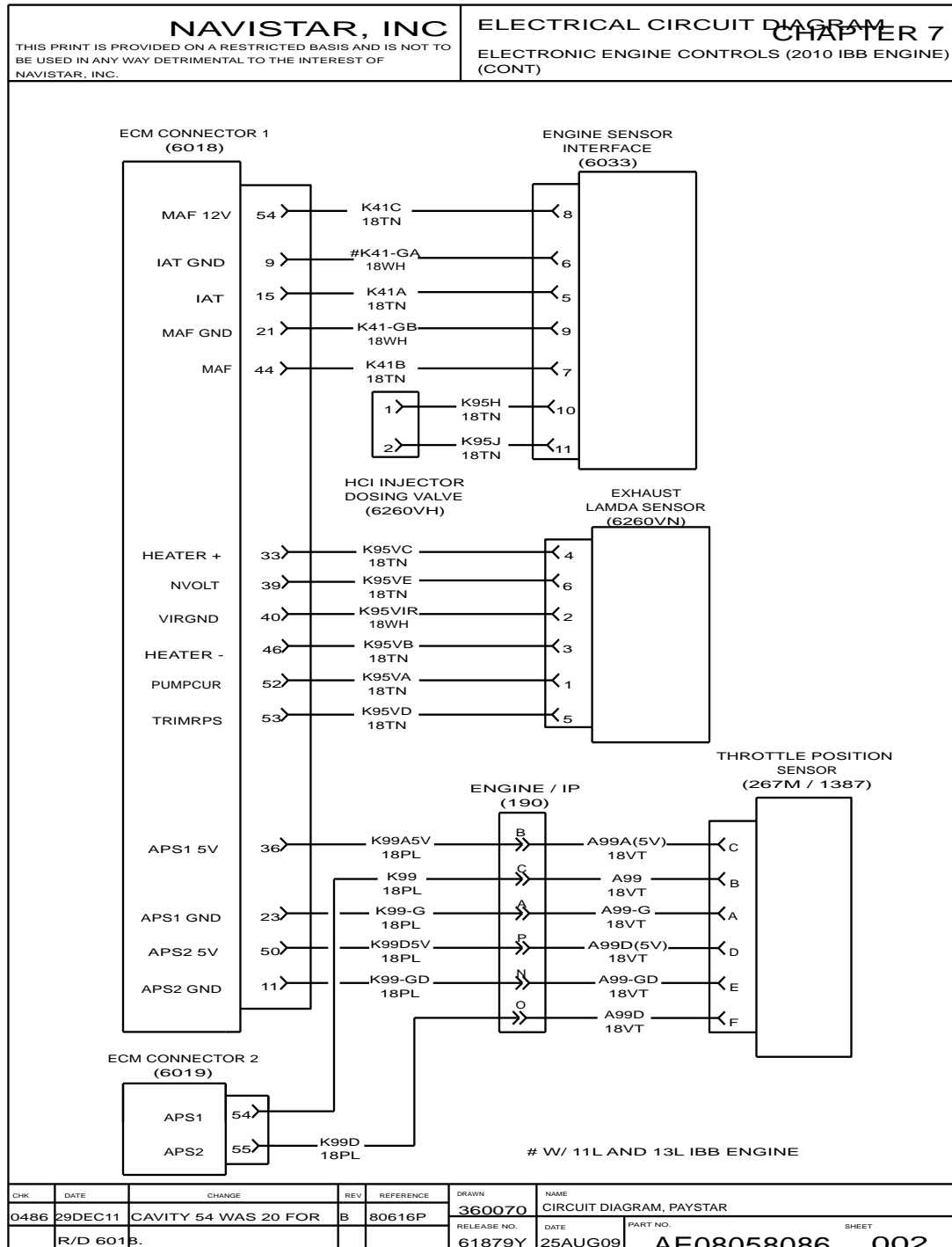


Figure 75 Electronic Engine Controls (2010 IBB Engine) (Cont.)

7.3. ELECTRONIC ENGINE CONTROLS (2010 IBB ENGINE) (CONT.), P. 3

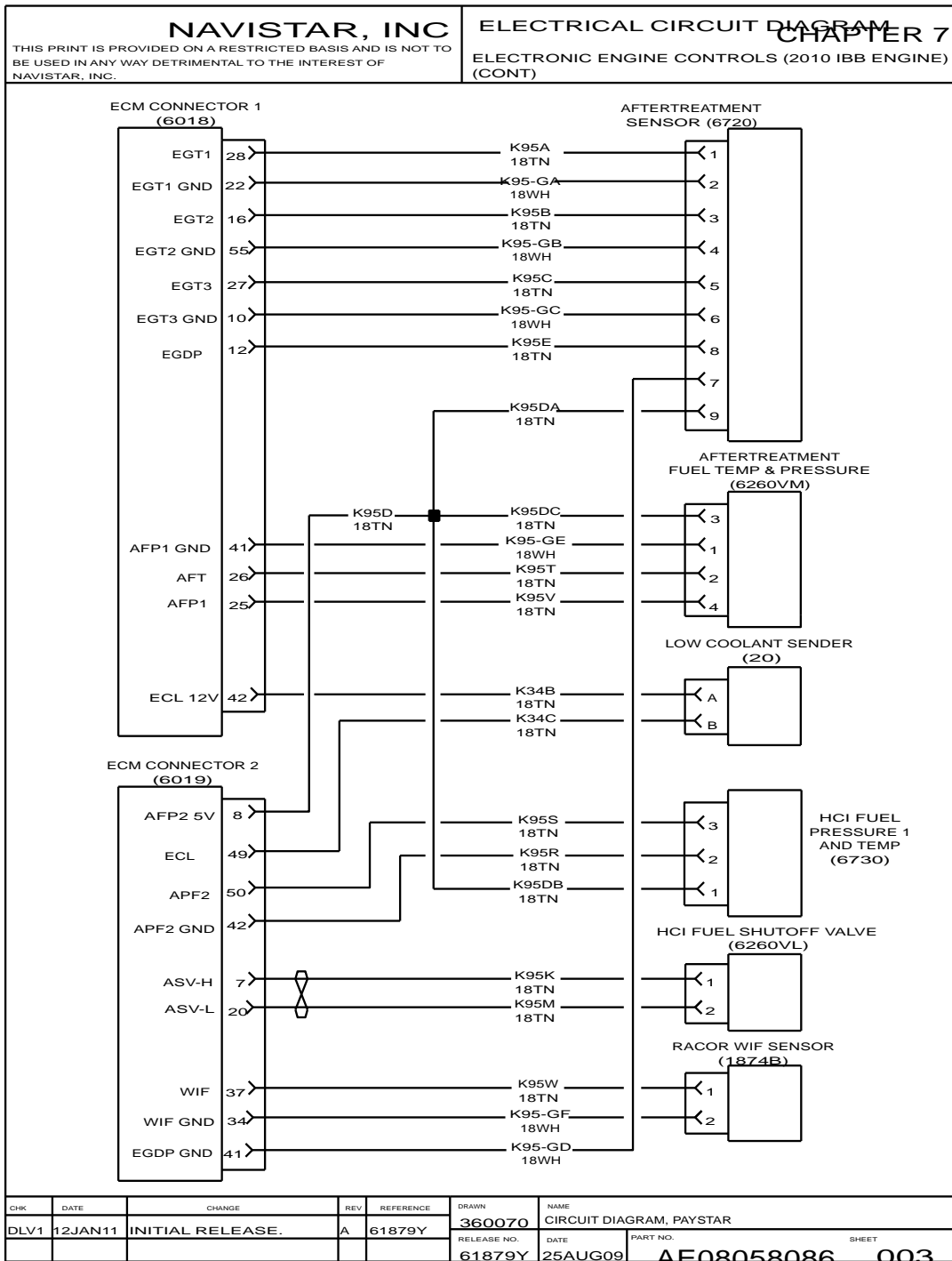


Figure 76 Electronic Engine Controls (2010 IBB Engine) (Cont.)

7.4. ELECTRONIC ENGINE CONTROLS (2010 IBB ENGINE) (CONT.), P. 3A

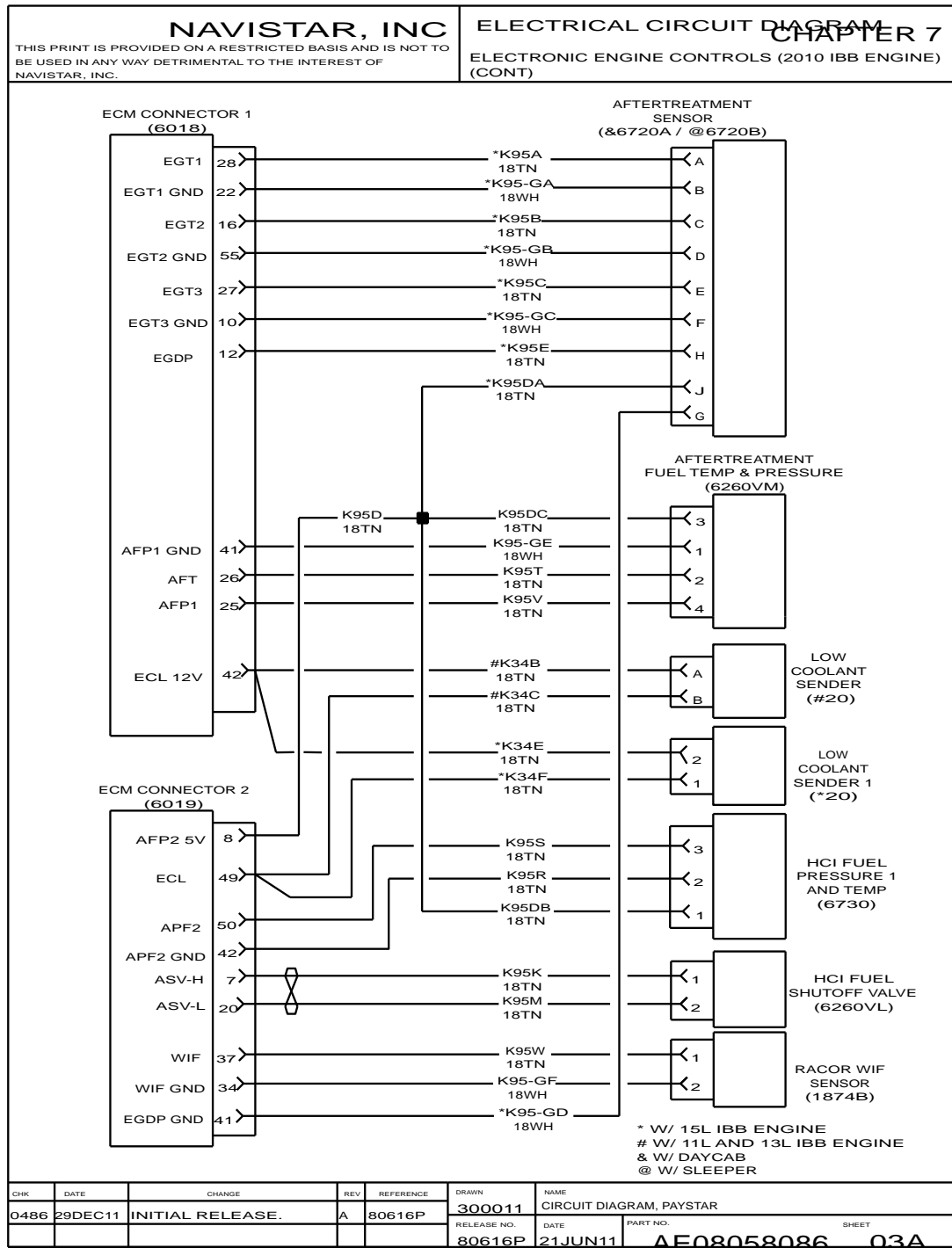


Figure 77 Electronic Engine Controls (2010 IBB Engine) (Cont.)

7.5. ELECTRONIC ENGINE CONTROLS (2010 IBB ENGINE) (CONT.), P. 4

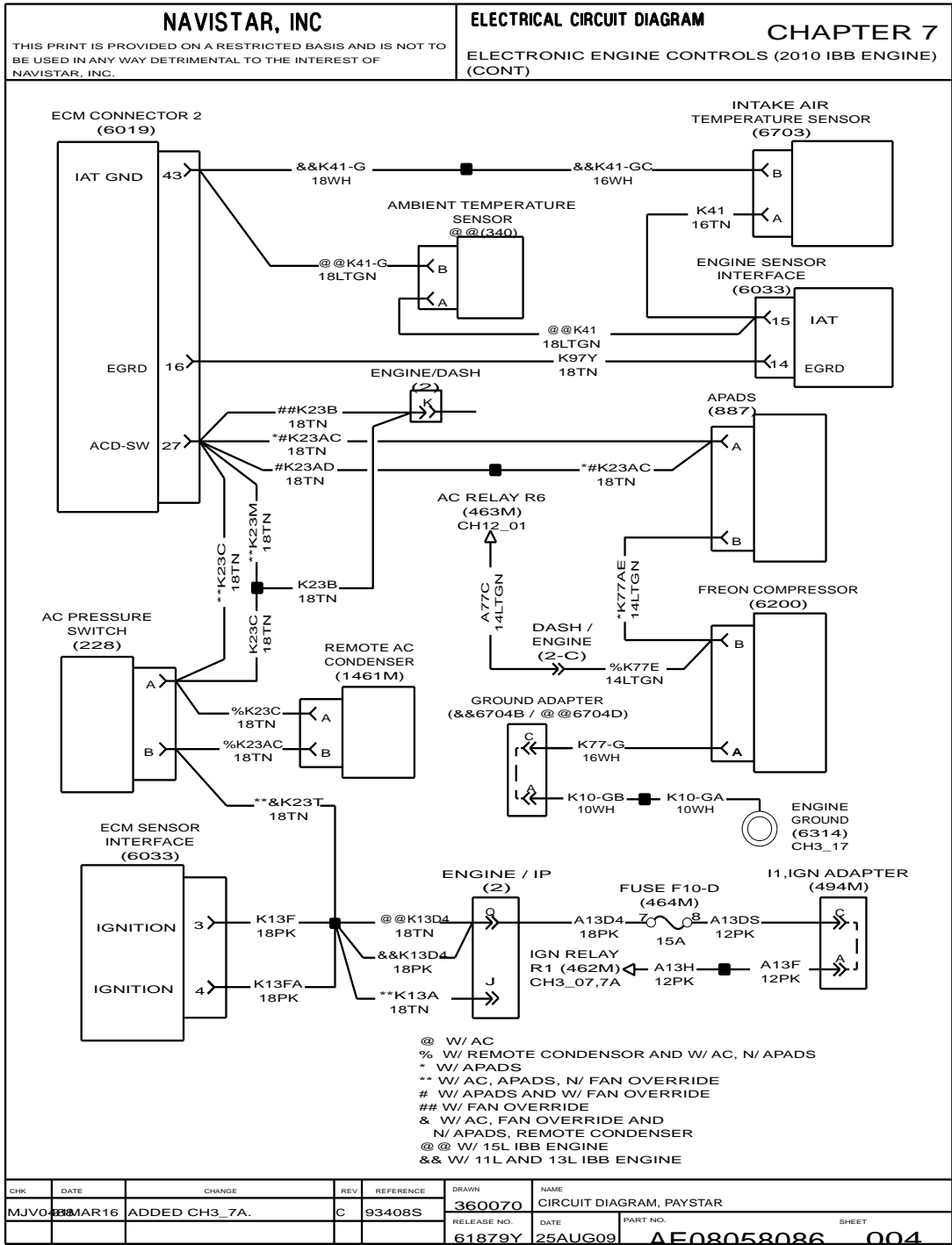


Figure 78 Electronic Engine Controls (2010 IBB Engine) (Cont.)



7.6. FAN DRIVE PROTECTION JUMPER, P. 4A

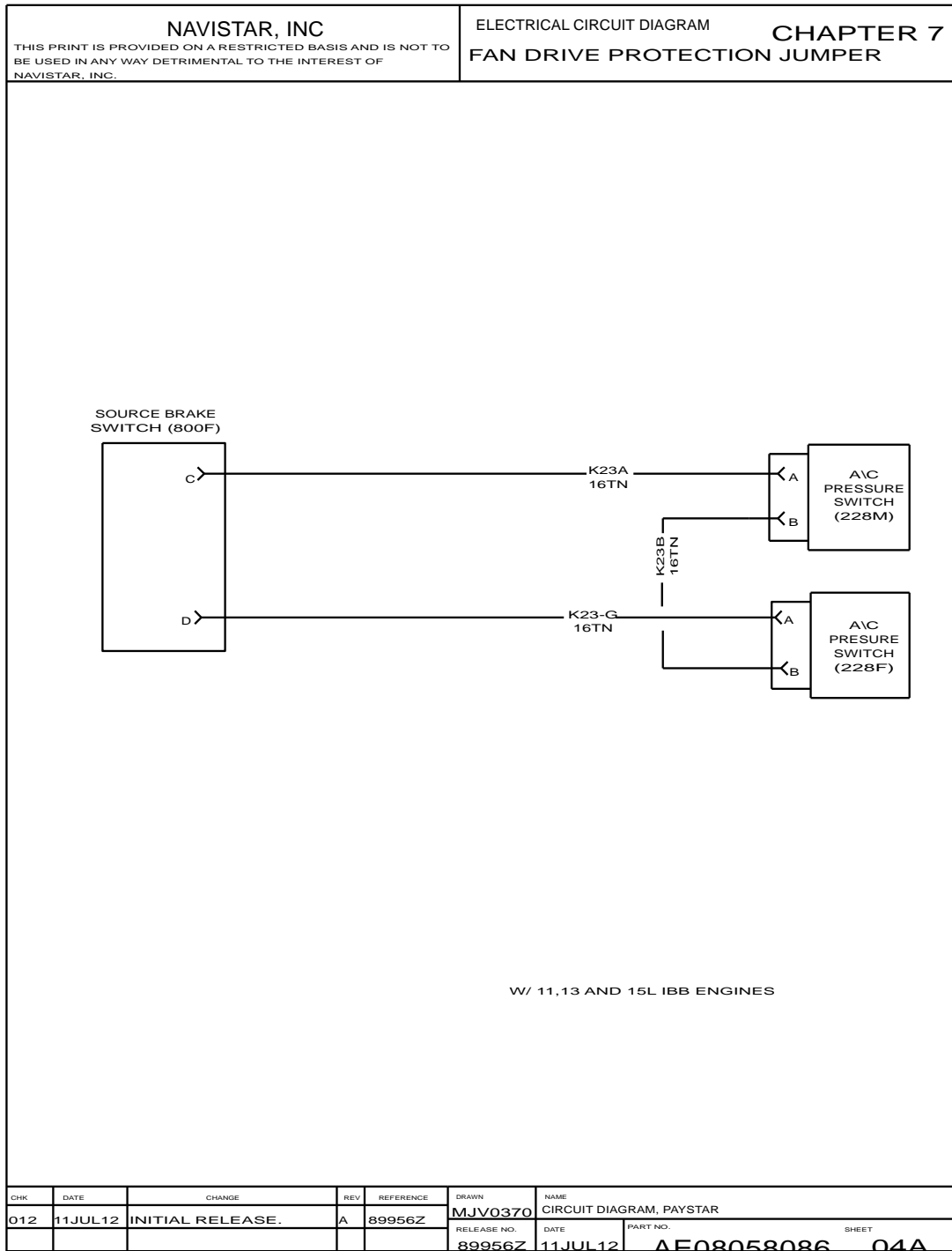


Figure 79 Fan Drive Protection Jumper

7.7. ELECTRONIC ENGINE CONTROLS (2010 IBB ENGINE) (CONT.), P. 5

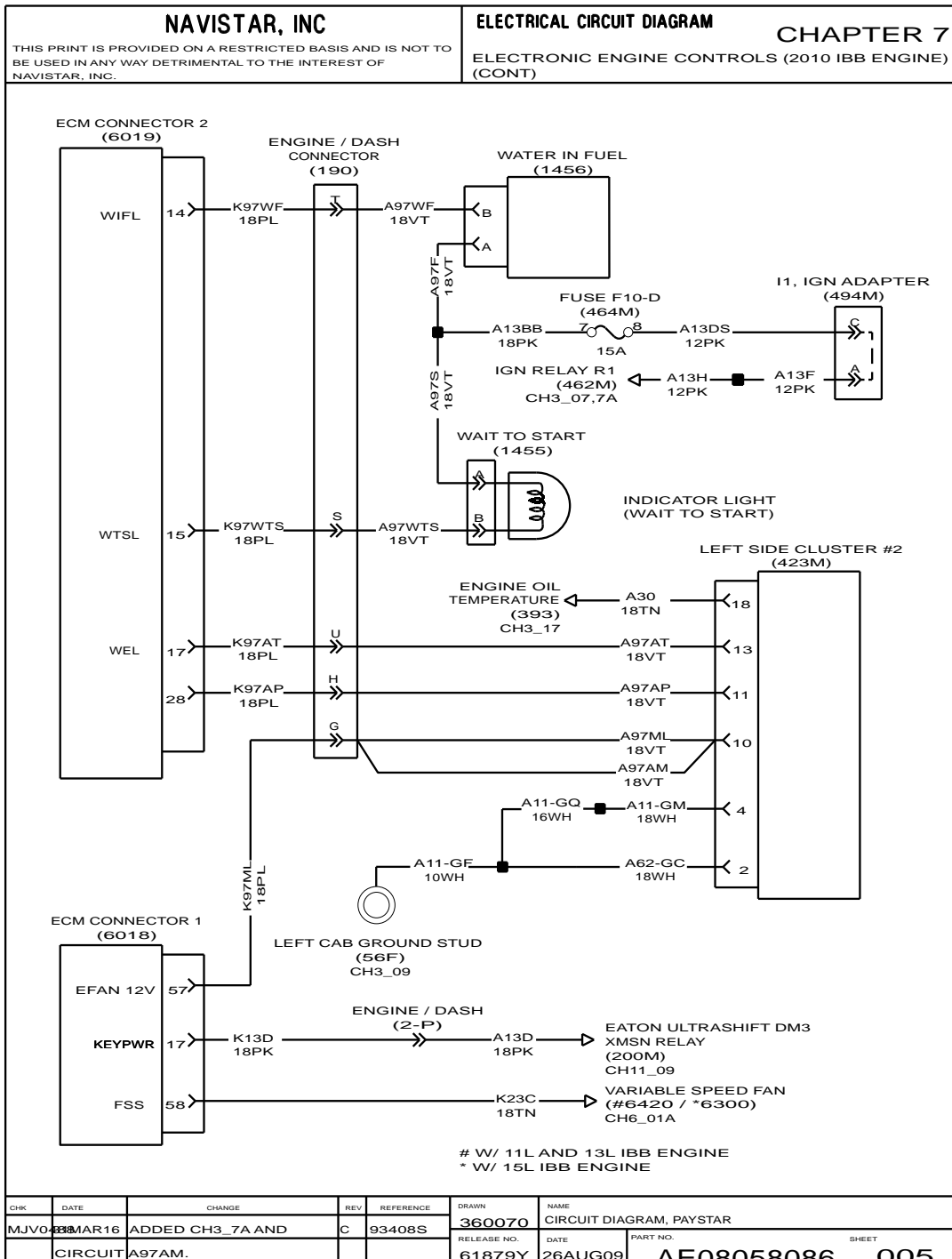


Figure 80 Electronic Engine Controls (2010 IBB Engine) (Cont.)

7.8. ELECTRONIC ENGINE CONTROLS (2010 IBB ENGINE) (CONT.), P. 6

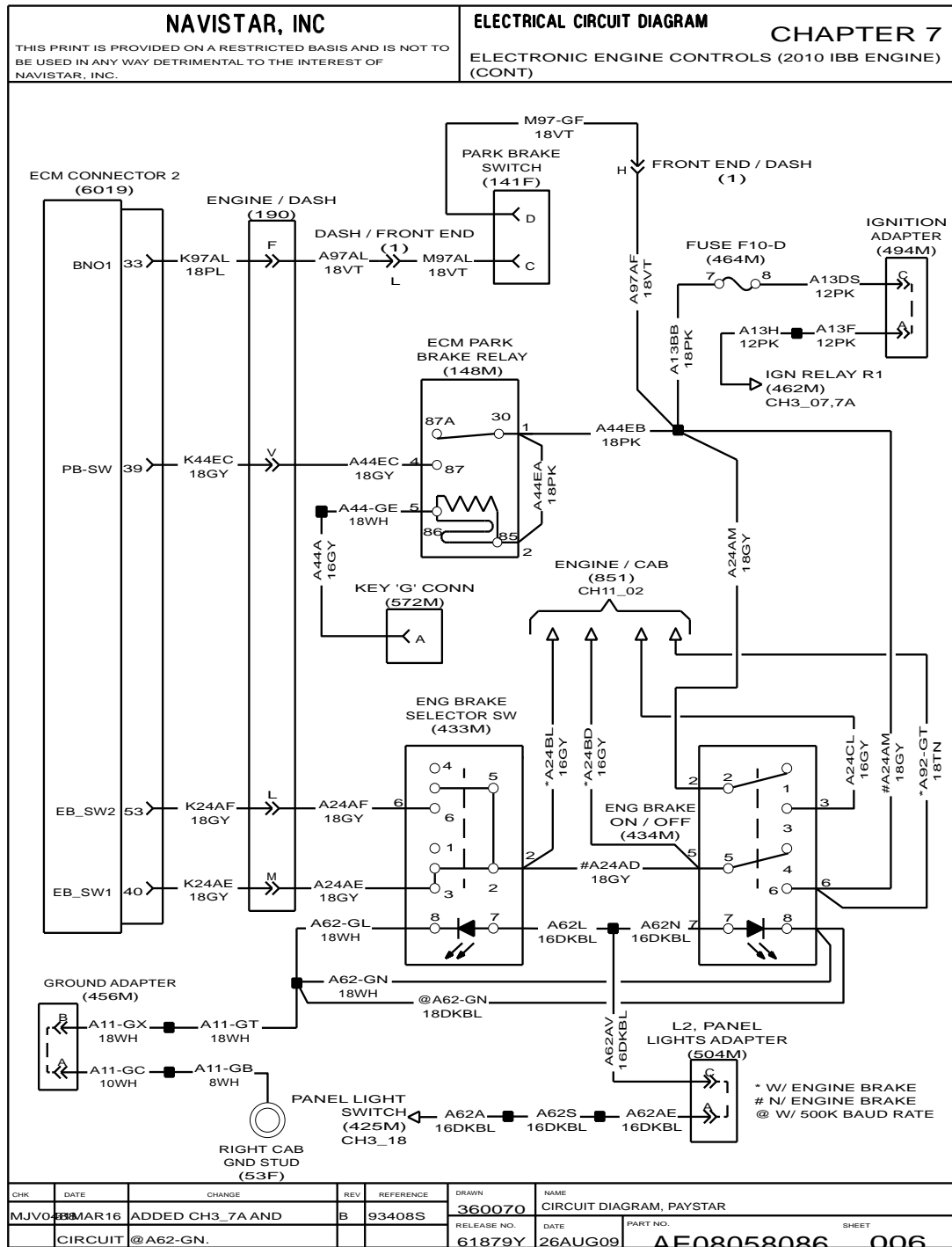


Figure 81 Electronic Engine Controls (2010 IBB Engine) (Cont.)

7.9. ELECTRONIC ENGINE CONTROLS (2010 IBB ENGINE) (CONT.), P. 7

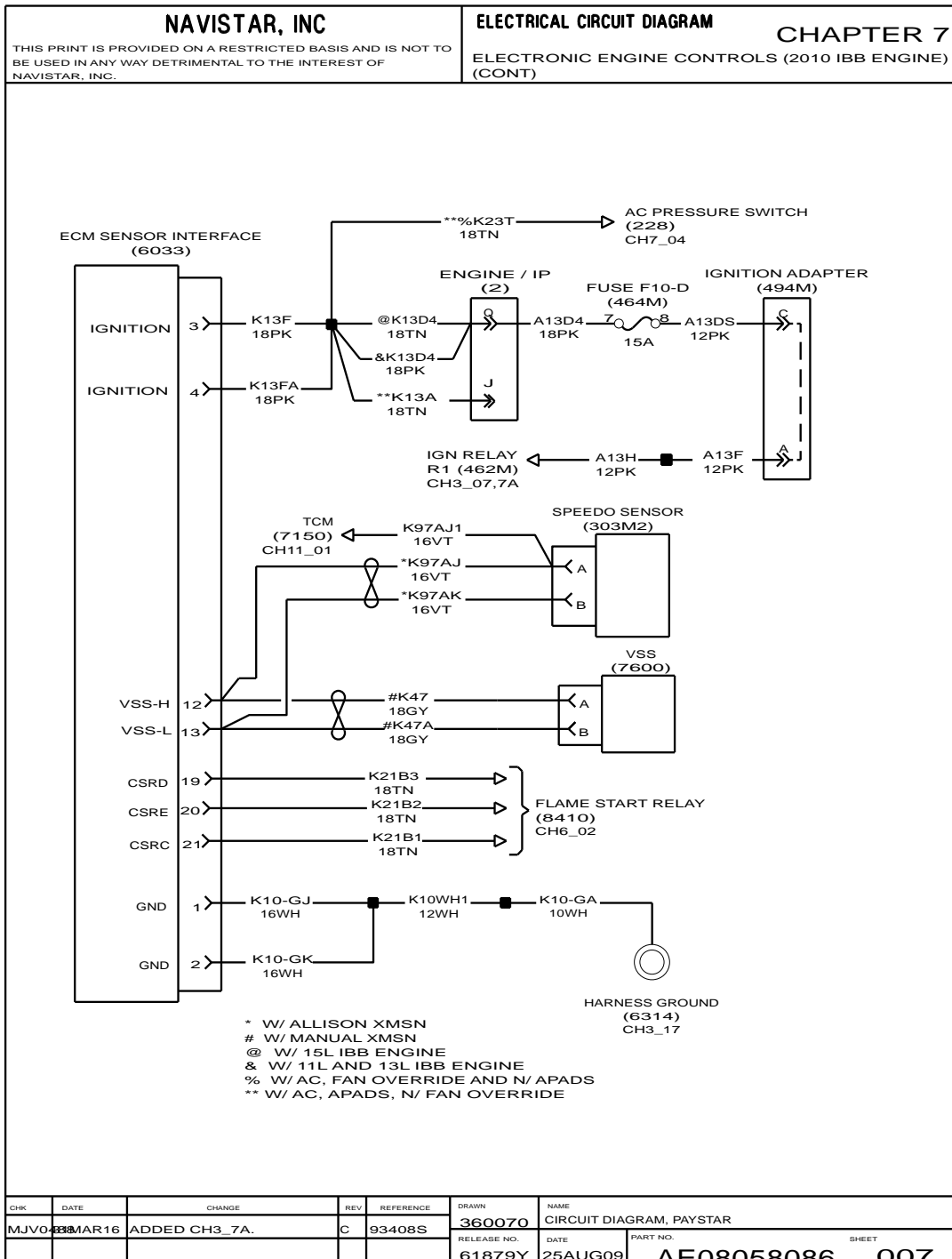


Figure 82 Electronic Engine Controls (2010 IBB Engine) (Cont.)

7.10. ELECTRONIC ENGINE CONTROLS (2010 IBB ENGINE) (CONT.), P. 8

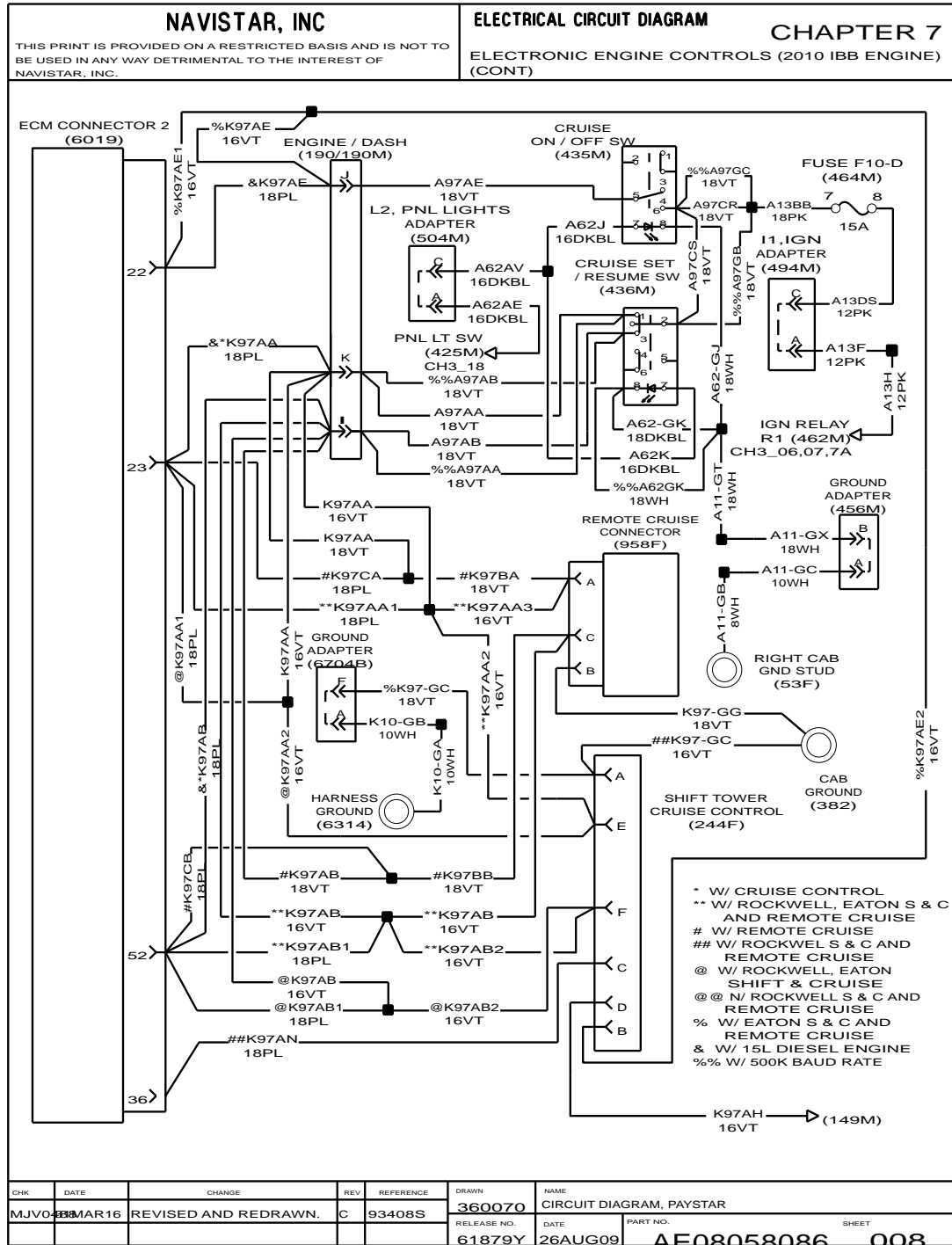


Figure 83 Electronic Engine Controls (2010 IBB Engine) (Cont.)

7.11. AFTERTREATMENT CONTROL, P. 9

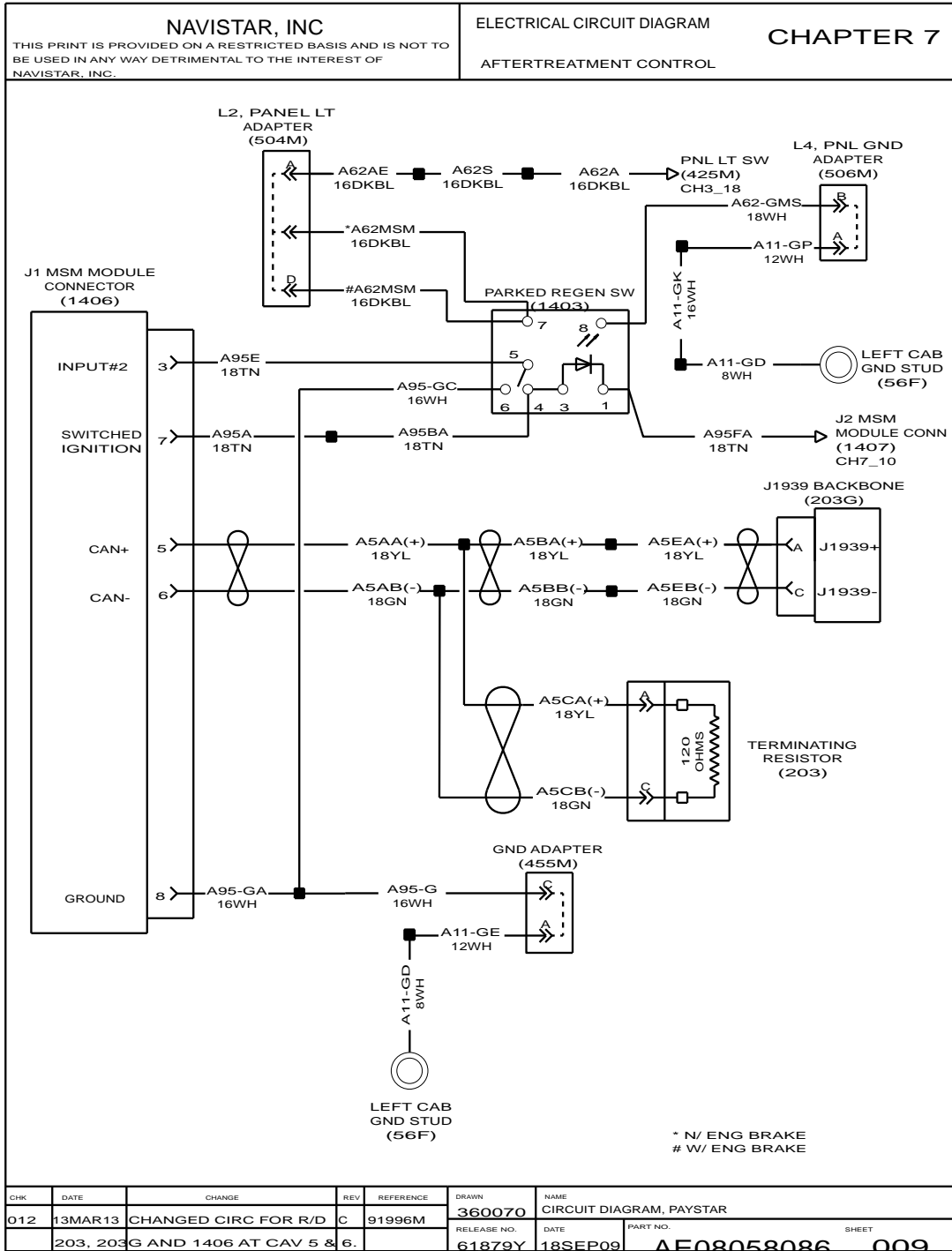


Figure 84 Aftertreatment Control

7.12. SART MODULE, P. 9A

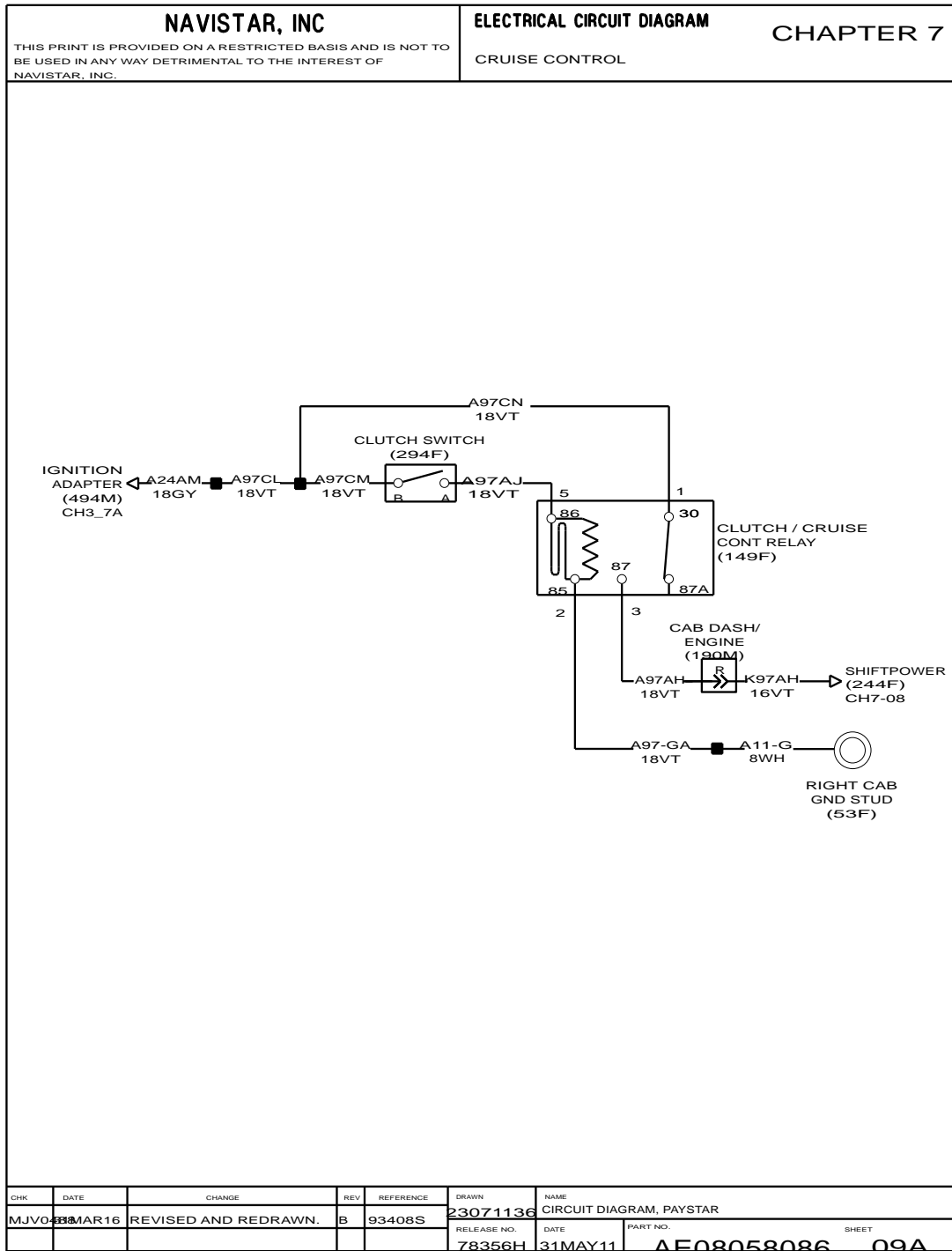


Figure 85 SART Module

7.13. AFTERTREATMENT CONTROL (CONT.), P. 10

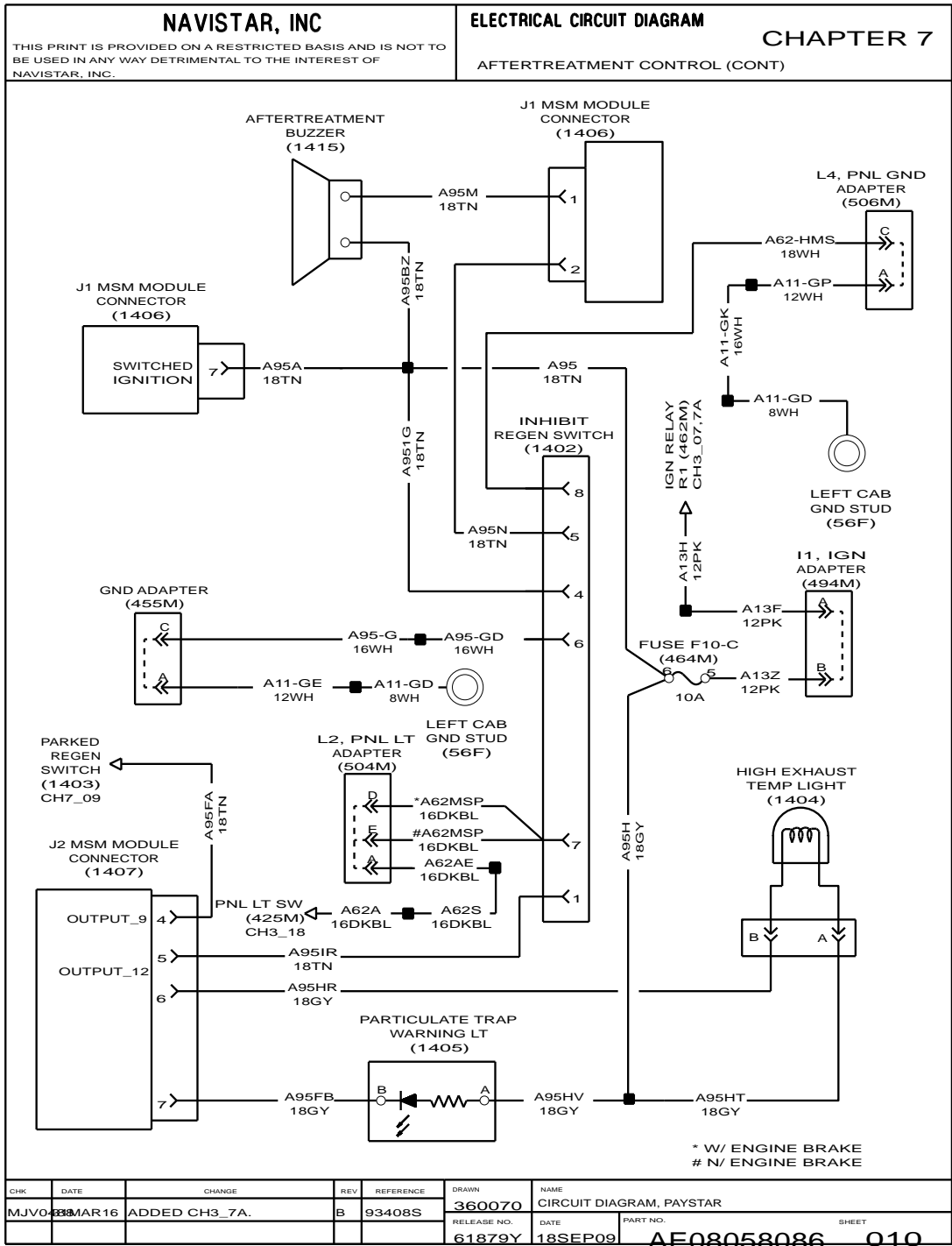


Figure 86 Aftertreatment Control (Cont.)



7.14. AFTERTREATMENT CONTROL WITH 500K BAUD RATE, P. 10A

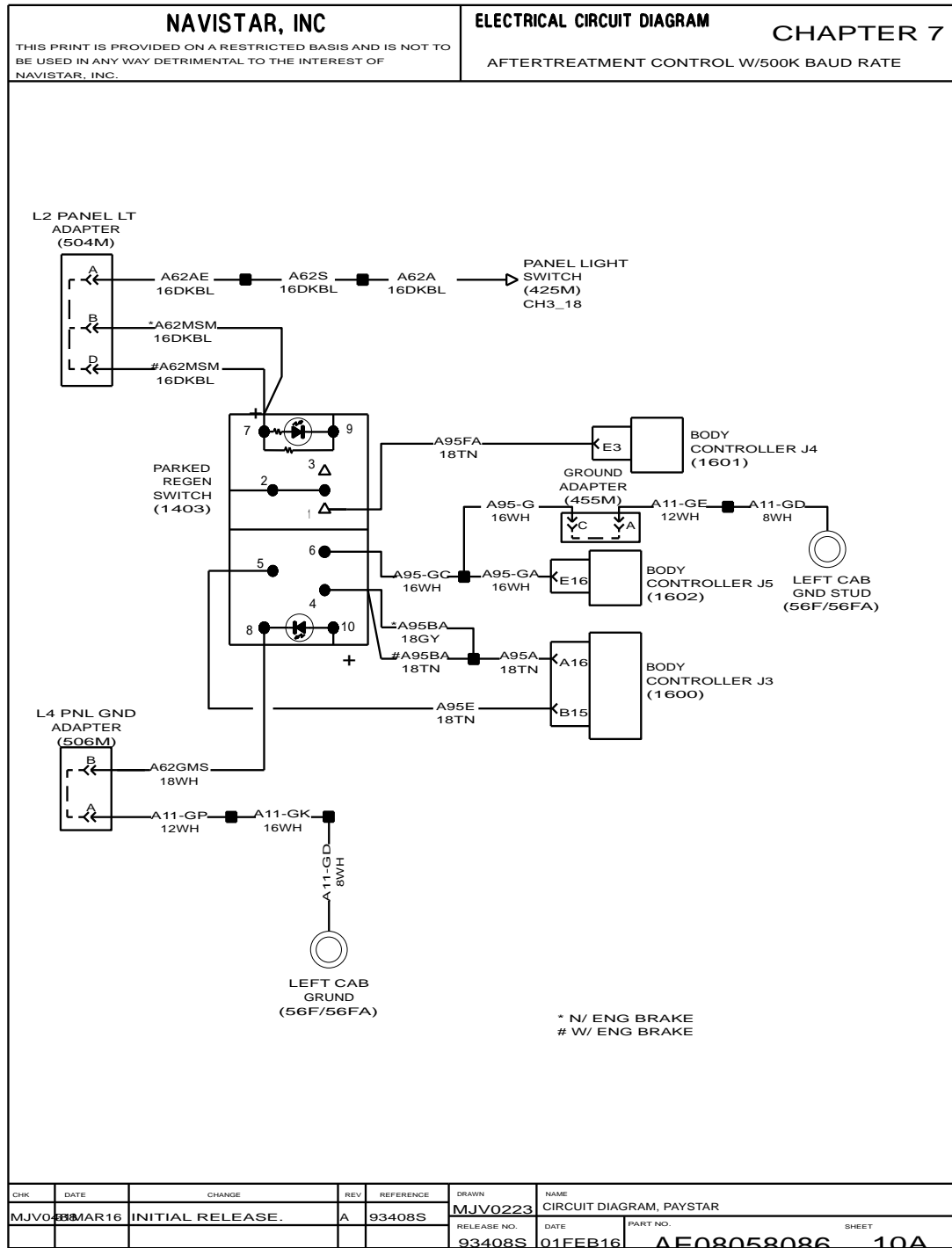


Figure 87 Aftertreatment Control with 500K Baud Rate

7.15. AFTERTREATMENT CONTROL WITH 500K BAUD RATE (CONT.), P. 10B

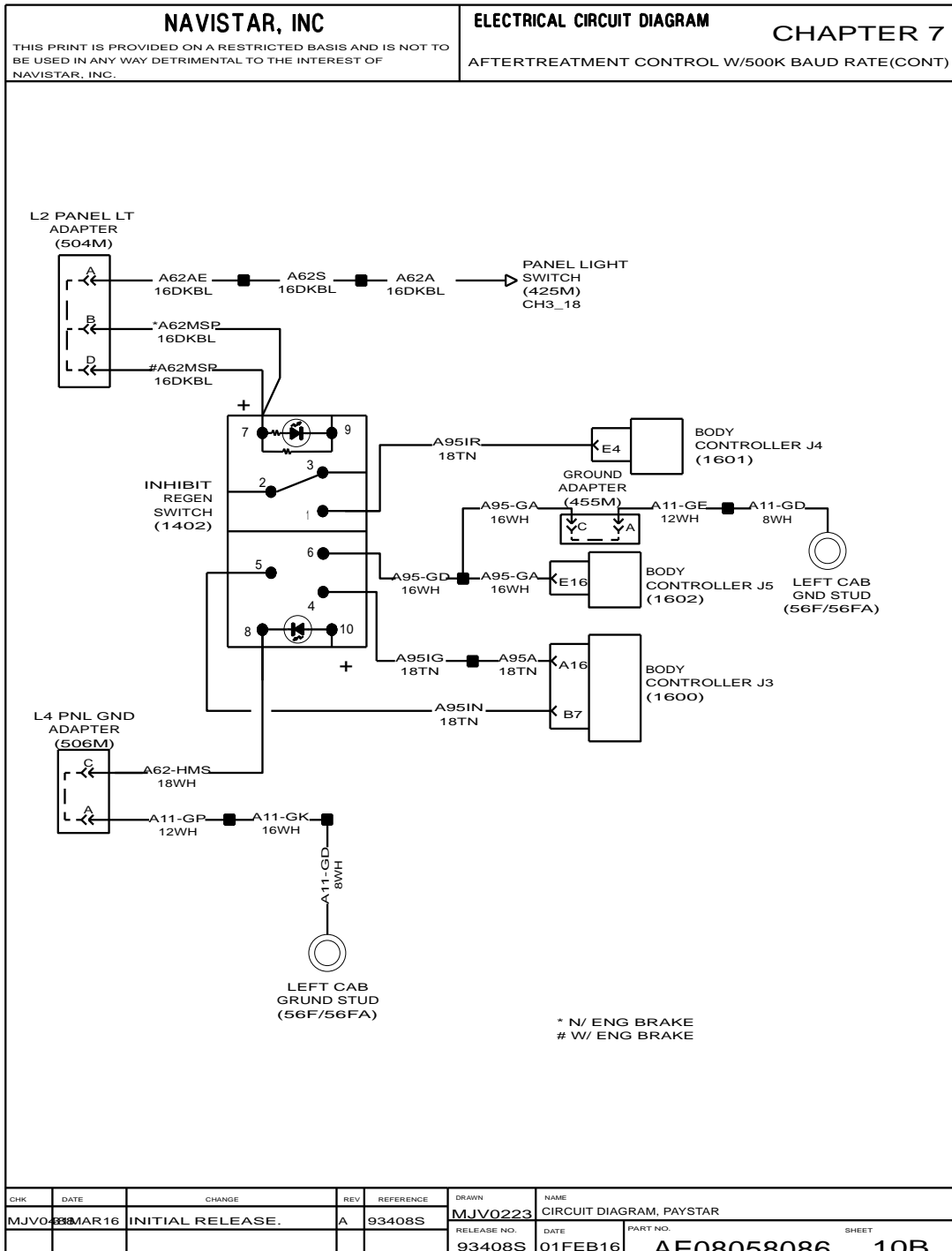


Figure 88 Aftertreatment Control with 500K Baud Rate (Cont.)

7.16. ELECTRONIC ENGINE CONTROLS (15L ENG) ISX 2013, P. 11

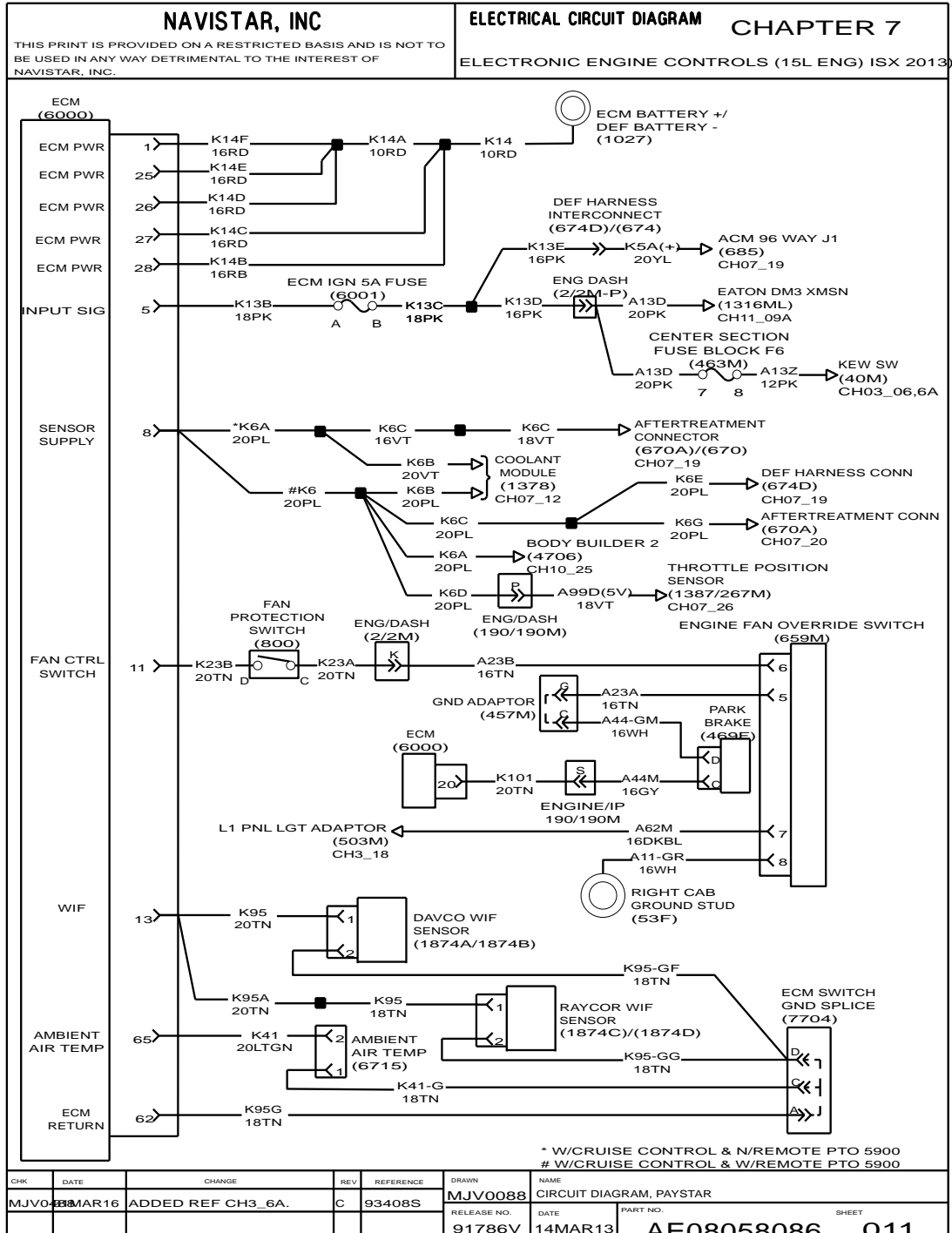


Figure 89 Electronic Engine Controls (15L Eng) ISX 2013

7.17. ELECTRONIC ENGINE CONTROLS (15L ENG) ISX 2013 (CONT.), P. 12

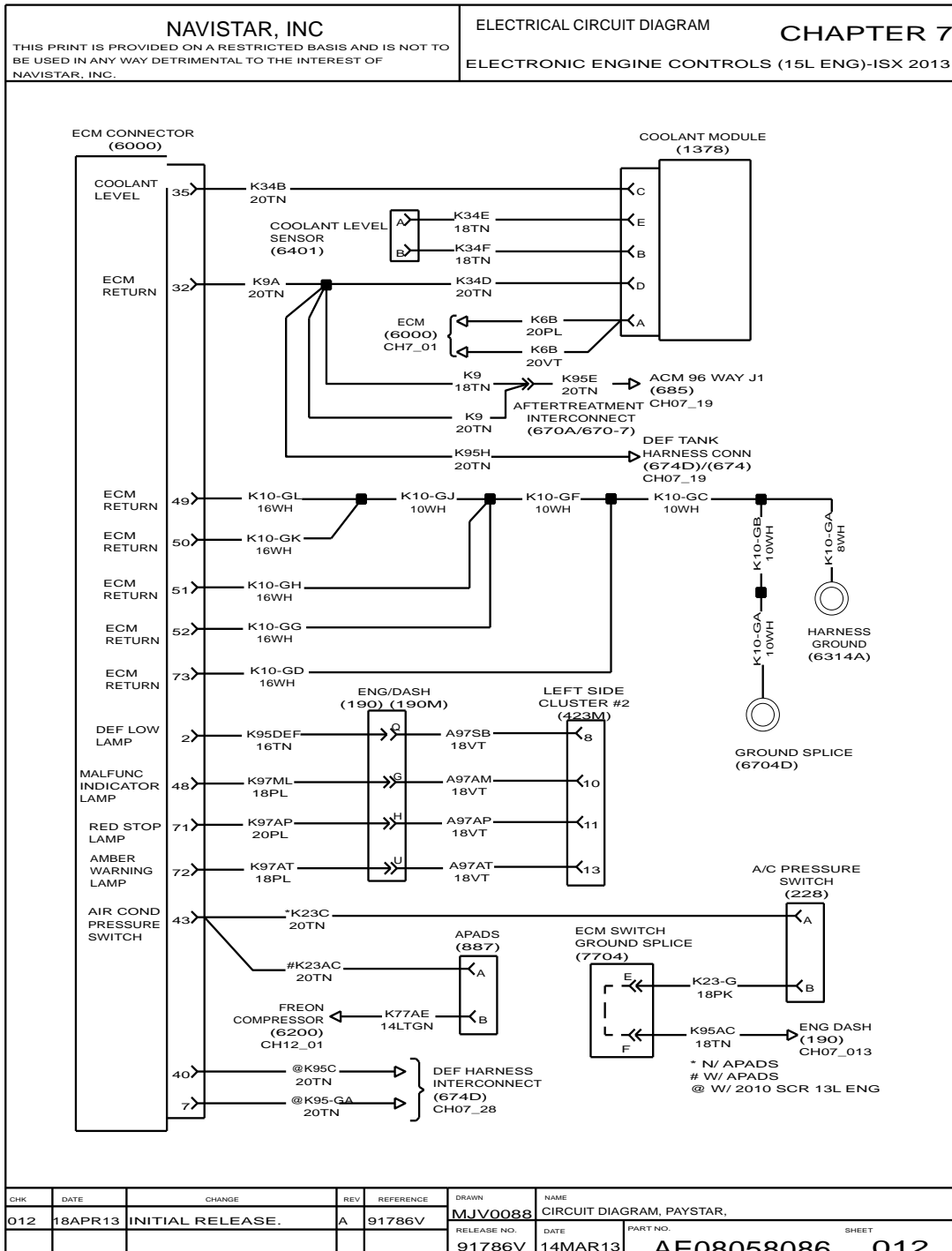


Figure 90 Electronic Engine Controls (15L Eng) ISX 2013 (Cont.)

7.18. 15L ENG & CRUISE CONTROL – ISX 2013, P. 13

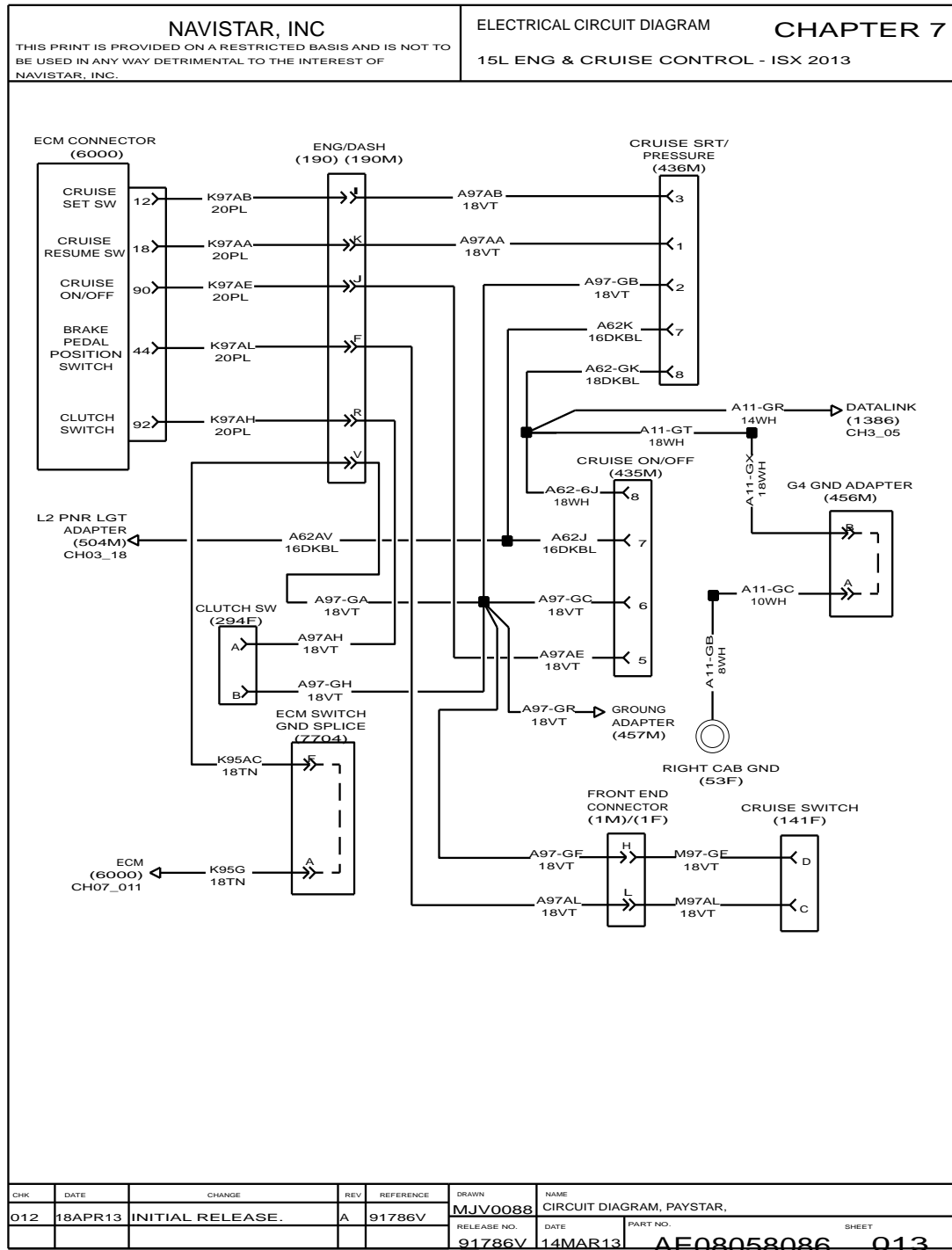


Figure 91 15L Eng & Cruise Control – ISX 2013

7.19. ELECTRONIC ENGINE CONTROLS (IBB ENGINE) – SCR EFFECTS, P. 14

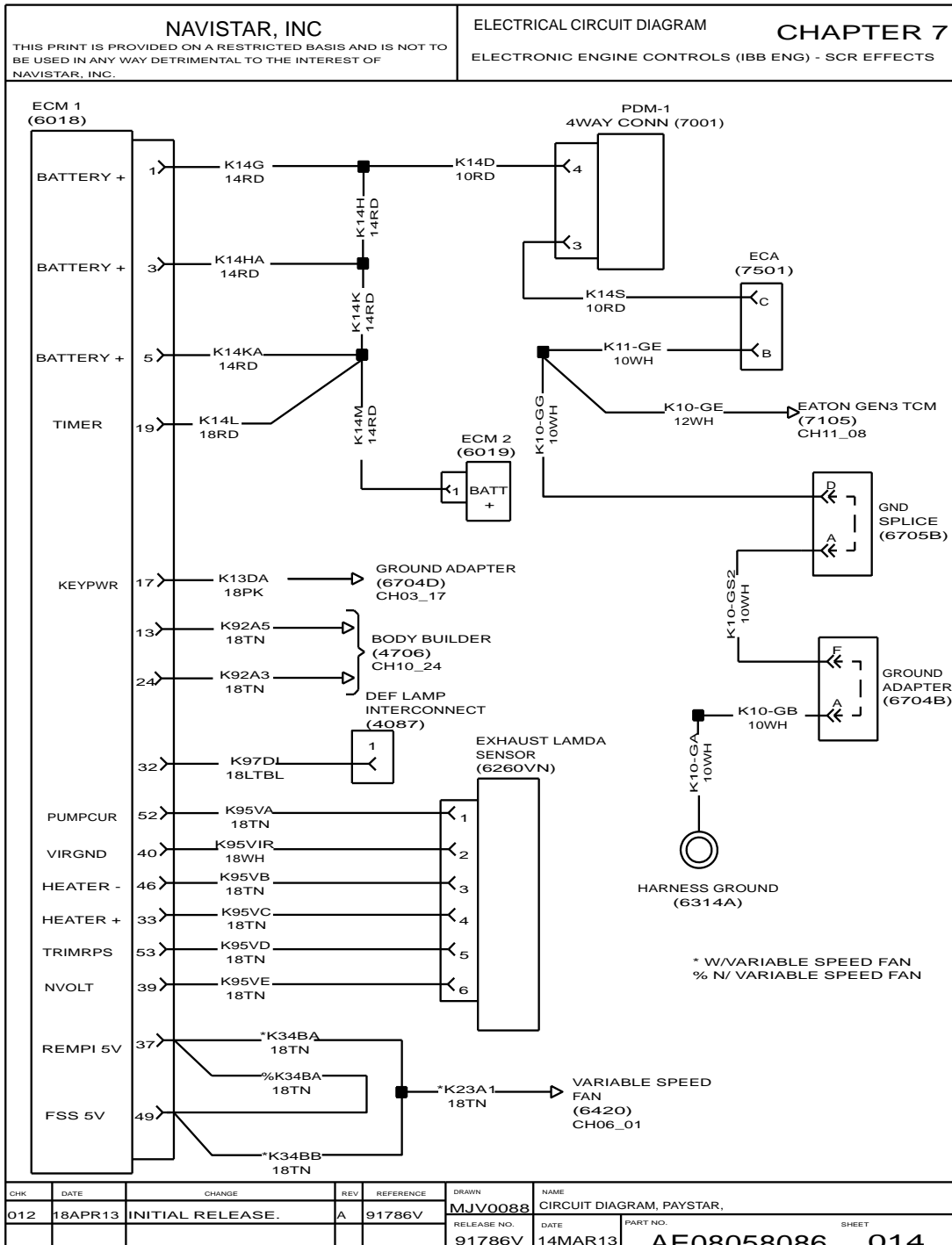


Figure 92 Electronic Engine Controls (IBB Engine) – SCR Effects

7.20. ELECTRONIC ENGINE CONTROLS (IBB ENGINE) – SCR EFFECTS (CONT.), P. 15

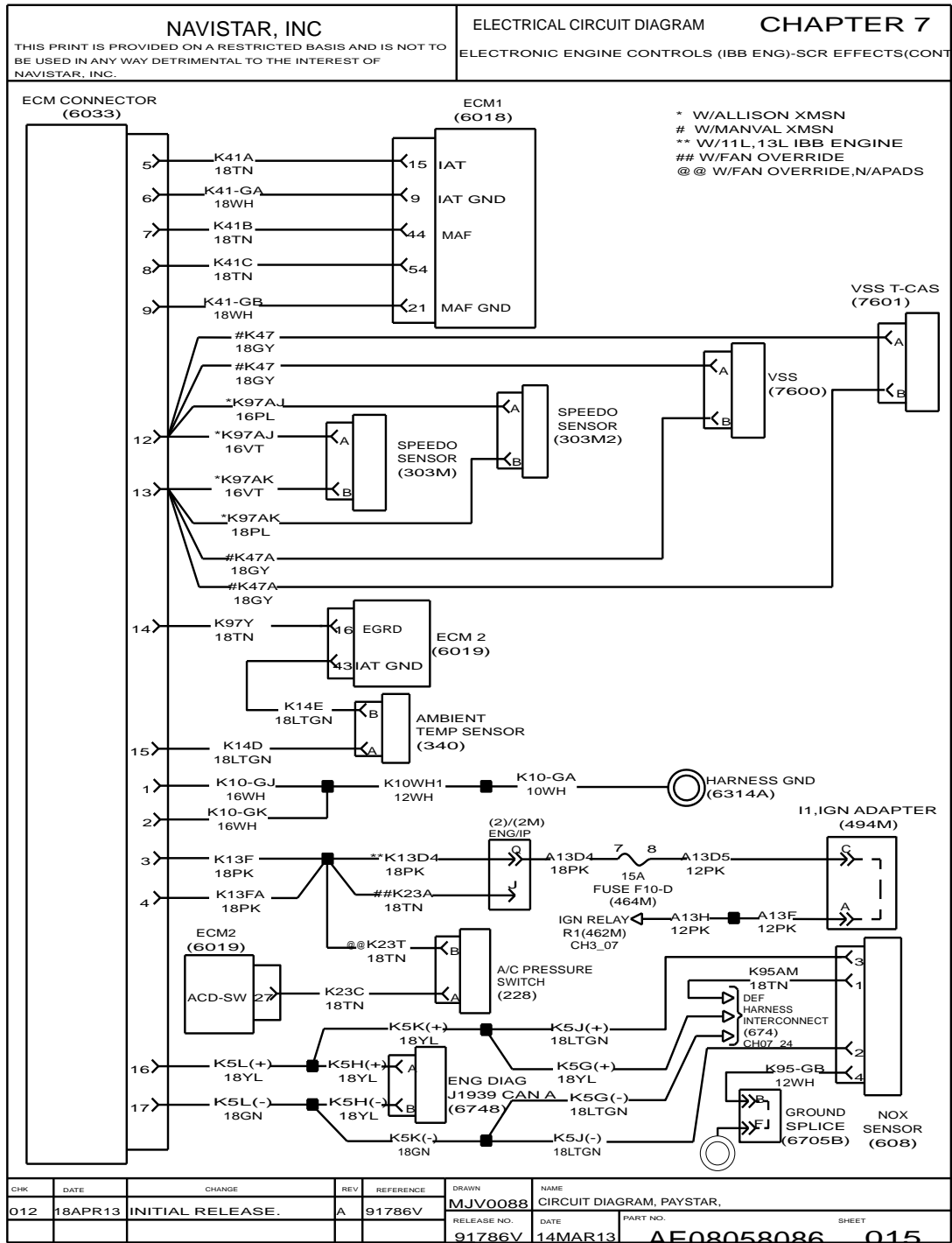


Figure 93 Electronic Engine Controls (IBB Engine) – SCR Effects (Cont.)

7.21. ELECTRONIC ENGINE CONTROLS (IBB ENGINE) – SCR EFFECTS (CONT.), P. 16

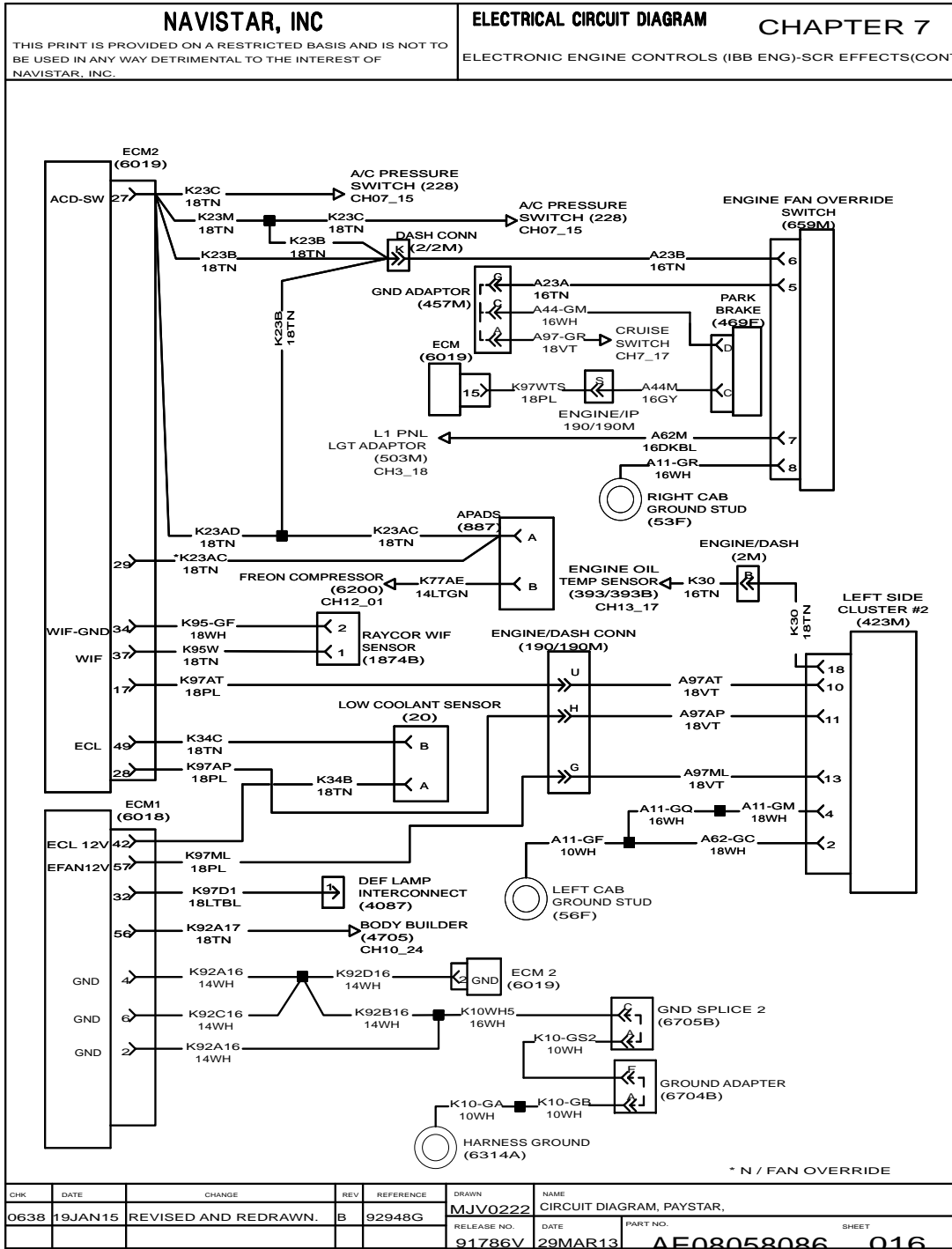


Figure 94 Electronic Engine Controls (IBB Engine) – SCR Effects (Cont.)



7.22. ELECTRONIC ENGINE CONTROLS (IBB ENGINE) – SCR EFFECTS (CONT.), P. 17

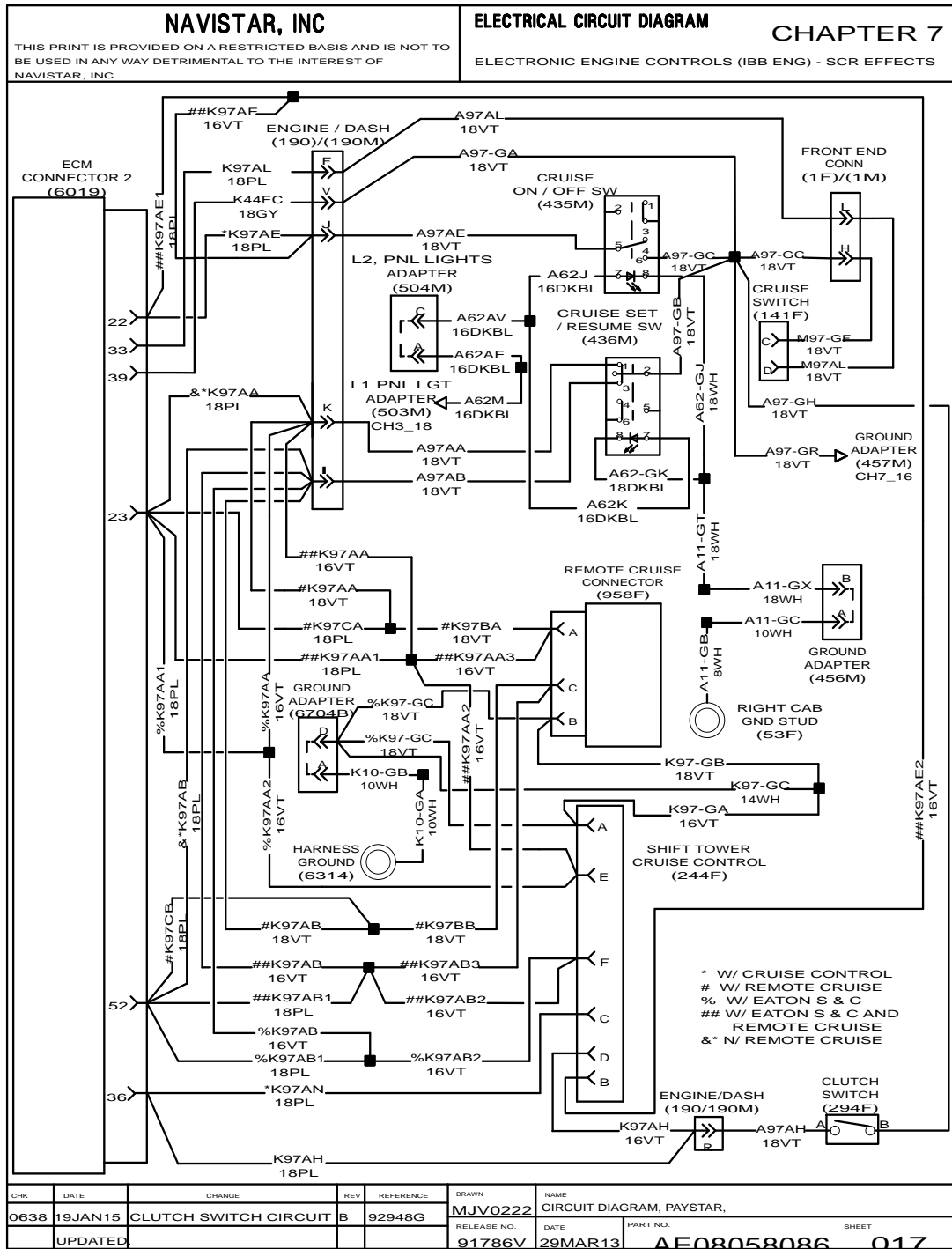


Figure 95 Electronic Engine Controls (IBB Engine) – SCR Effects (Cont.)

7.23. 11L / 13L IBB ENG CRUISE CONTROL – SCR EFFECTS, P. 18

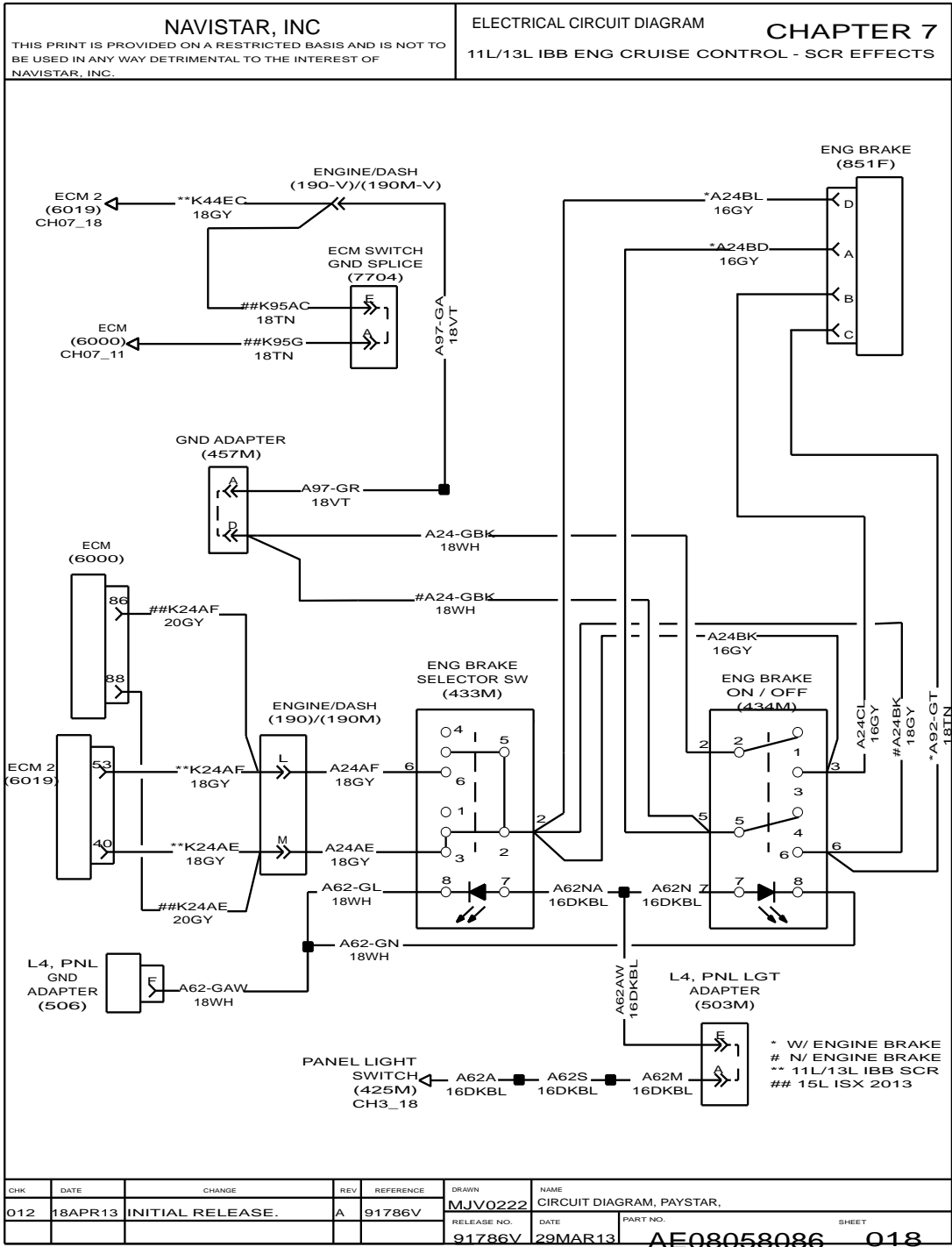


Figure 96 11L / 13L IBB Eng Cruise Control – SCR Effects

7.24. ISX 2013 DEF & AFTERTREATMENT (15L), P. 19

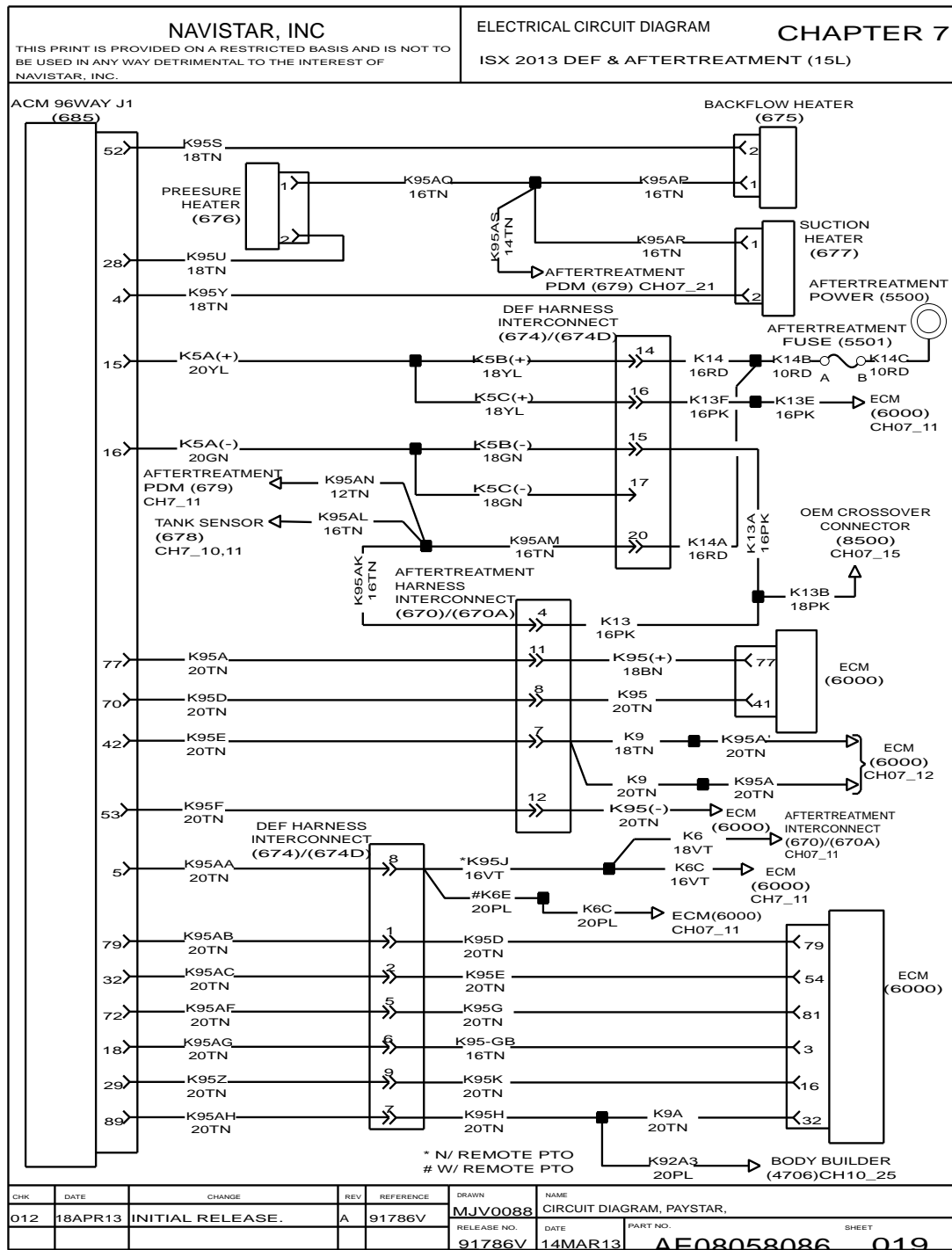


Figure 97 ISX 2013 DEF & Aftertreatment (15L)

7.25. ISX 2013 DEF & AFTERTREATMENT (15L) (CONT.), P. 20

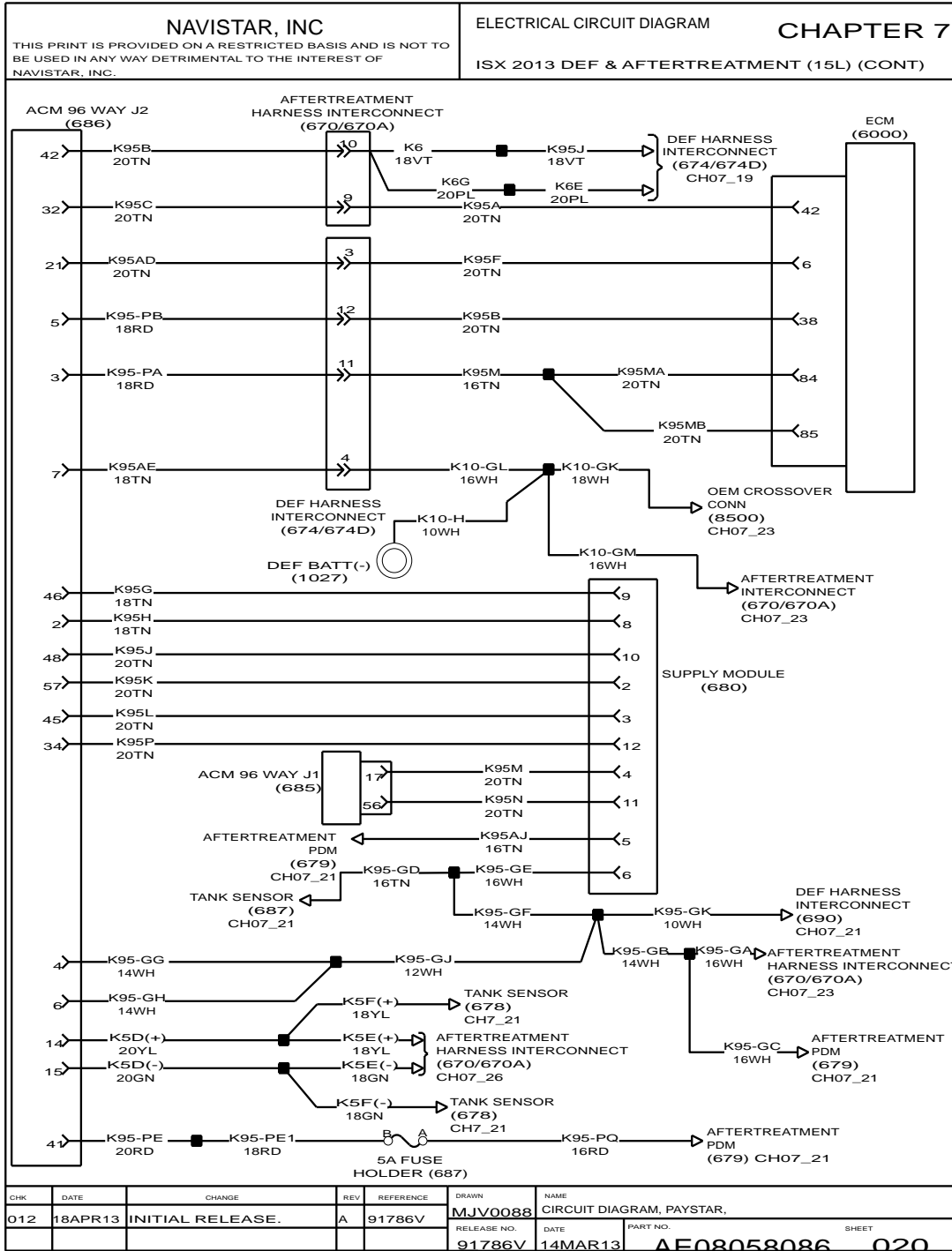


Figure 98 ISX 2013 DEF & Aftertreatment (15L) (Cont.)

7.26. ISX 2013 DEF & AFTERTREATMENT (15L) (CONT.), P. 21

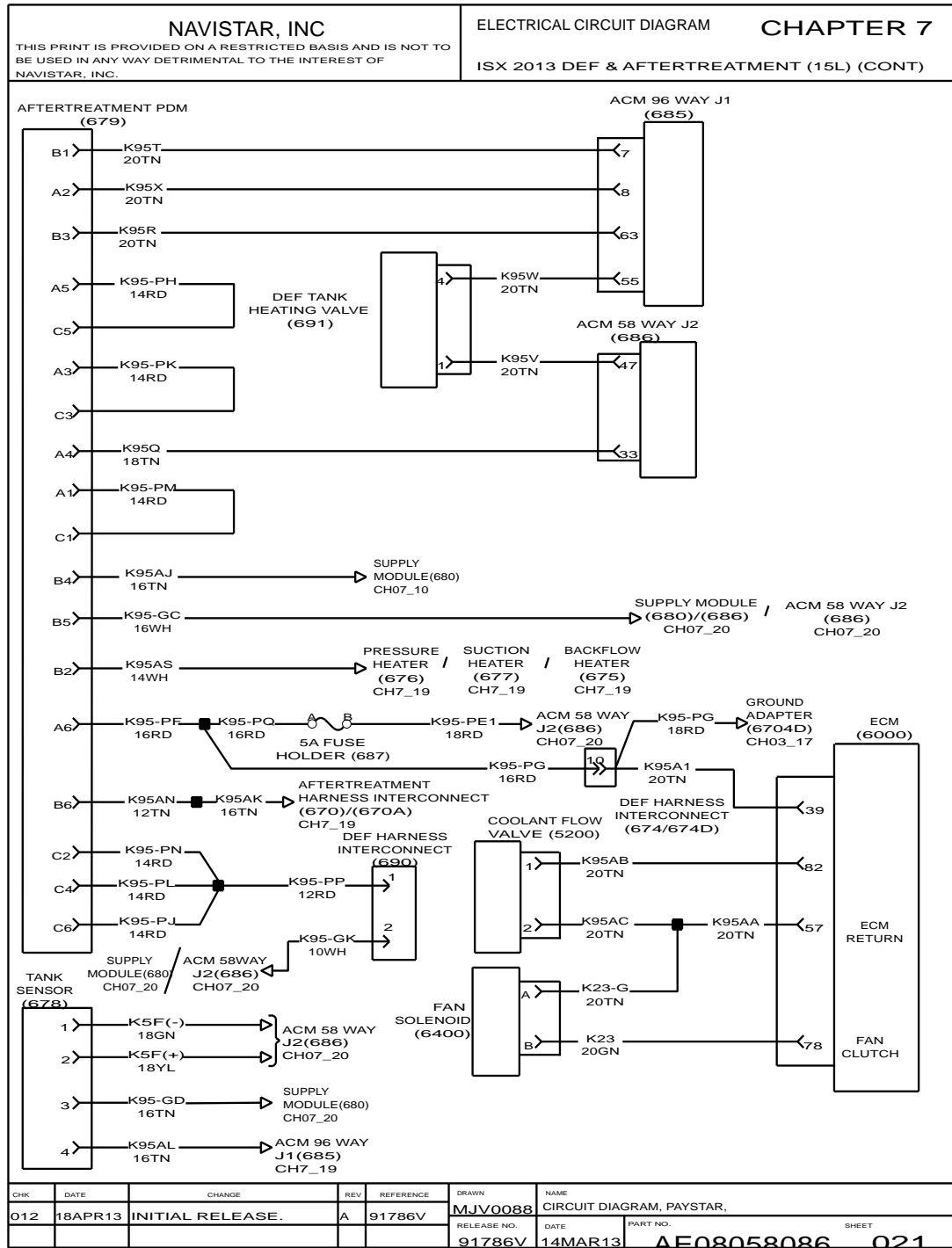


Figure 99 ISX 2013 DEF & Aftertreatment (15L) (Cont.)

7.27. ISX 2013 DEF & AFTERTREATMENT (15L) (CONT.), P. 22

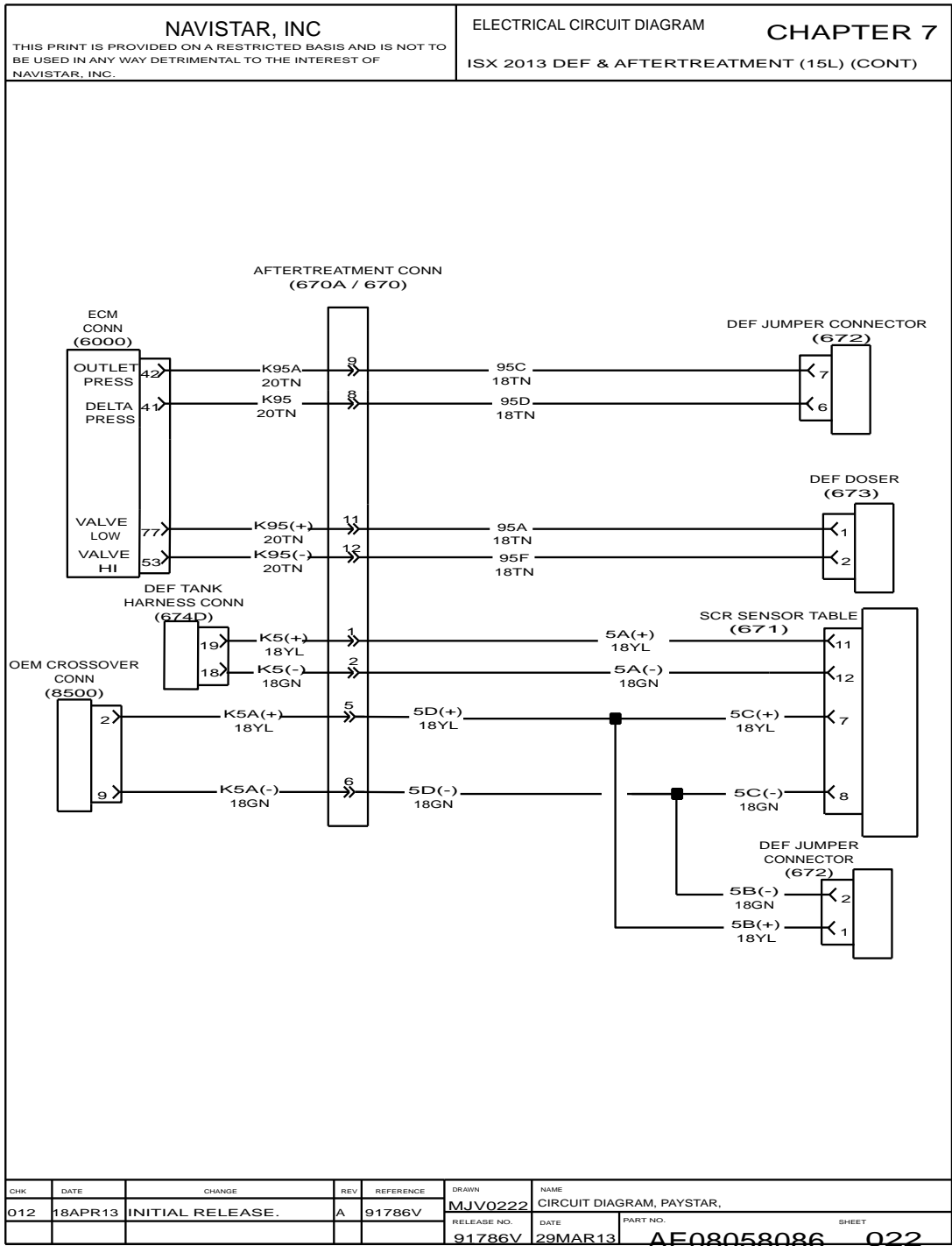


Figure 100 ISX 2013 DEF & Aftertreatment (15L) (Cont.)

7.28. ISX 2013 DEF & AFTERTREATMENT (15L) (CONT.), P. 23

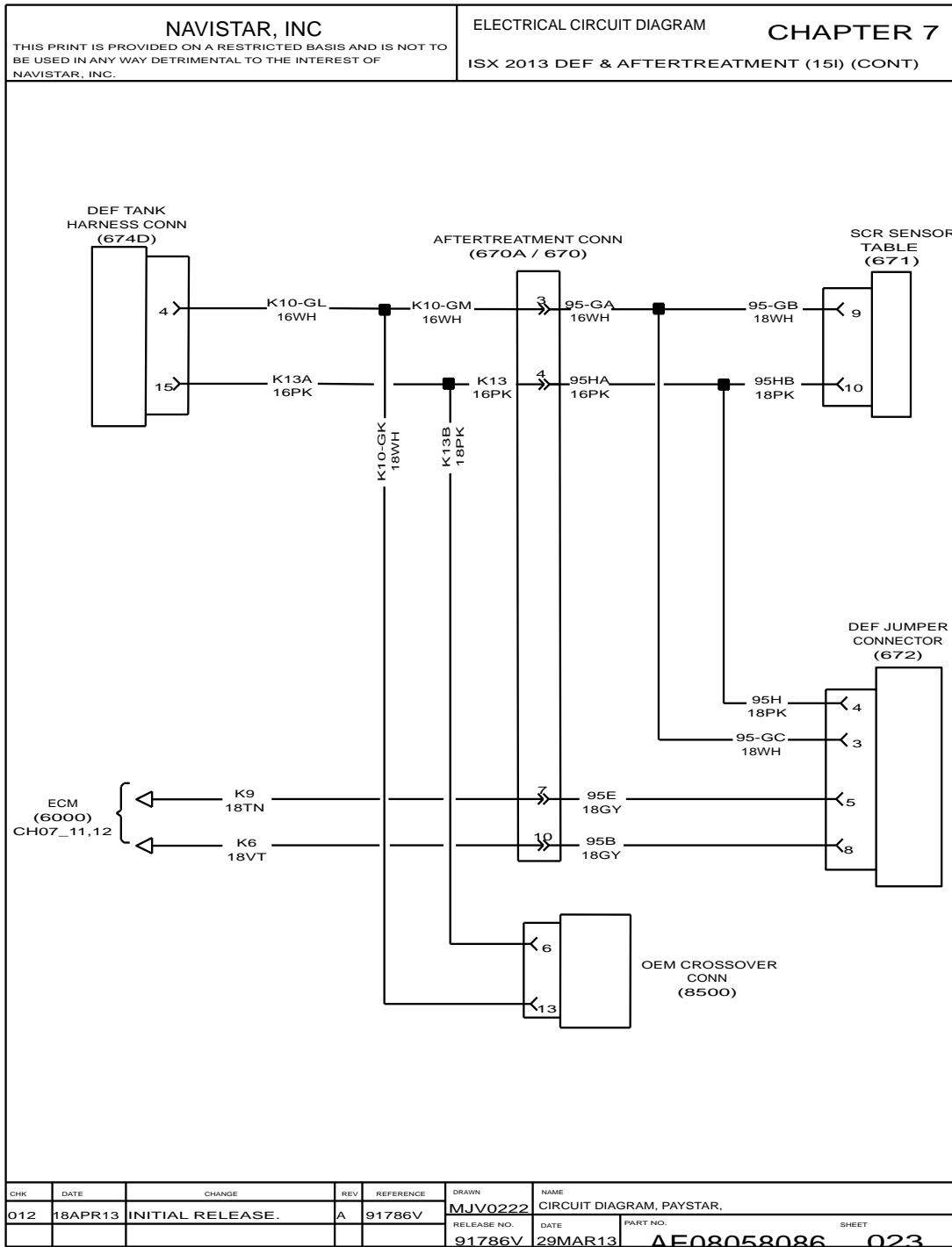


Figure 101 ISX 2013 DEF & Aftertreatment (15L) (Cont.)

7.29. DEF & AFTERTREATMENT (IBB SCR ENG), P. 24

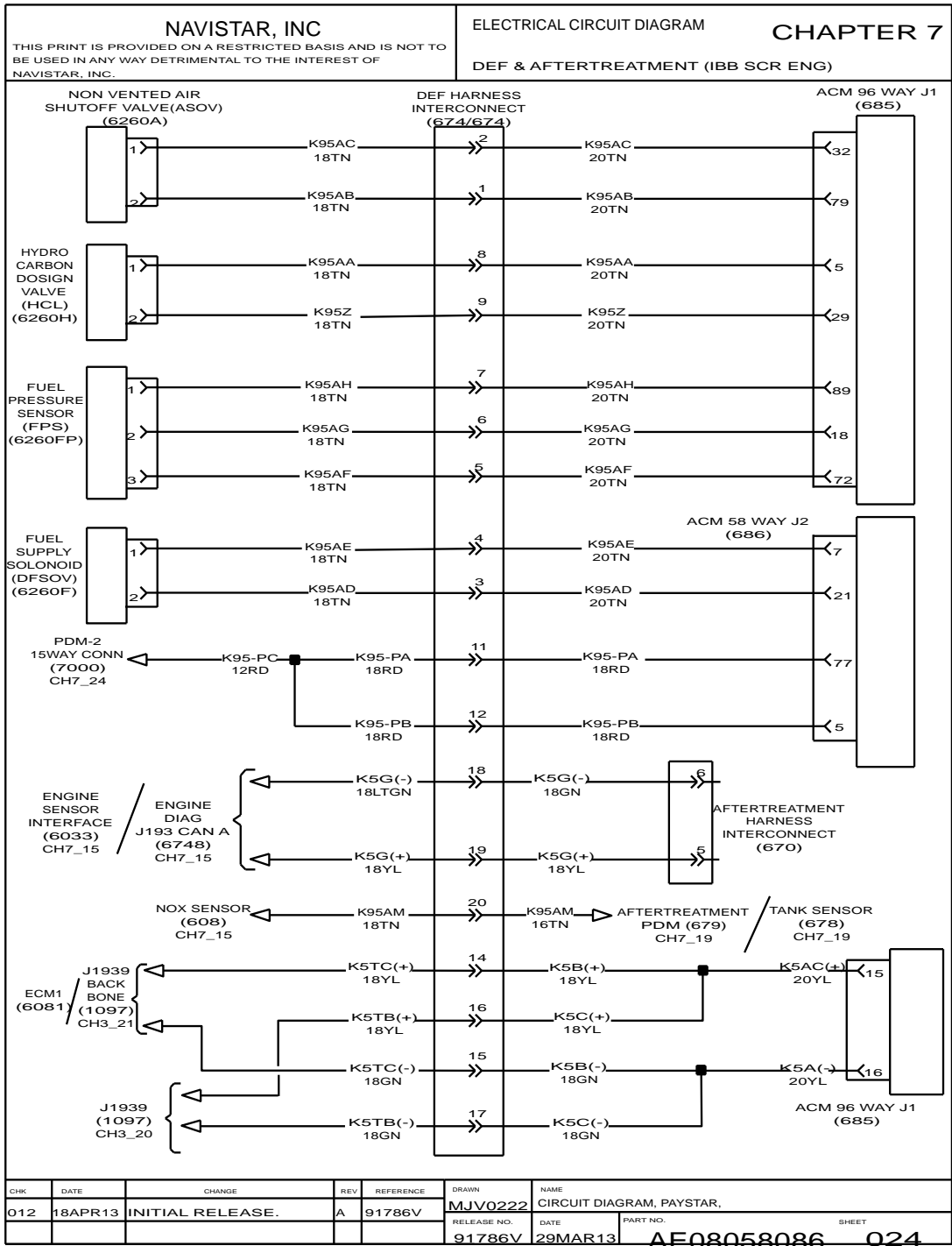


Figure 102 DEF & Aftertreatment (IBB SCR ENG)



7.30. DEF & AFTERTREATMENT (IBB SCR ENG) (CONT.), P. 25

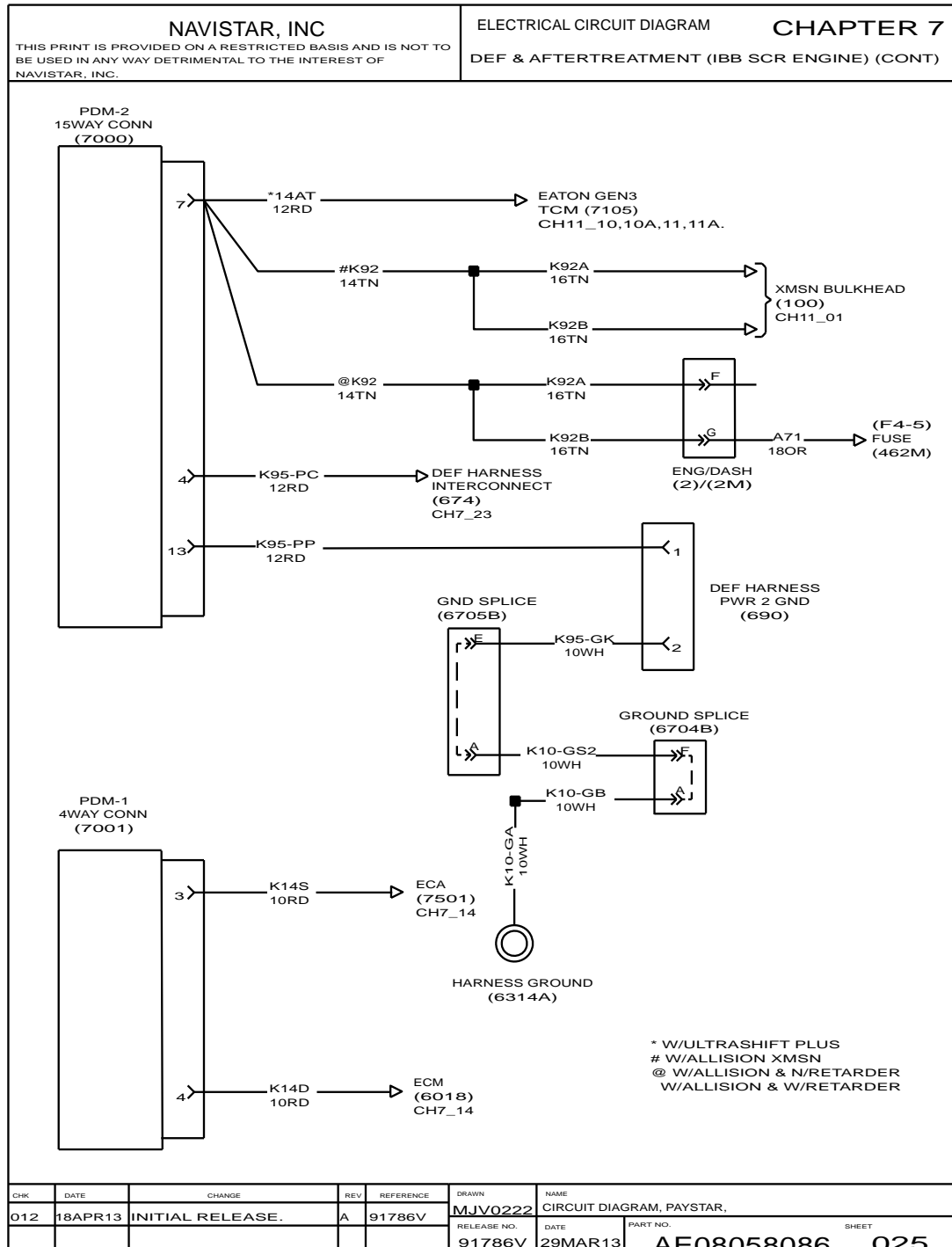


Figure 103 DEF & Aftertreatment (IBB SCR ENG) (Cont.)

7.31. 15L ISX & IBB SCR ENG THROTTLE POSITION, P. 26

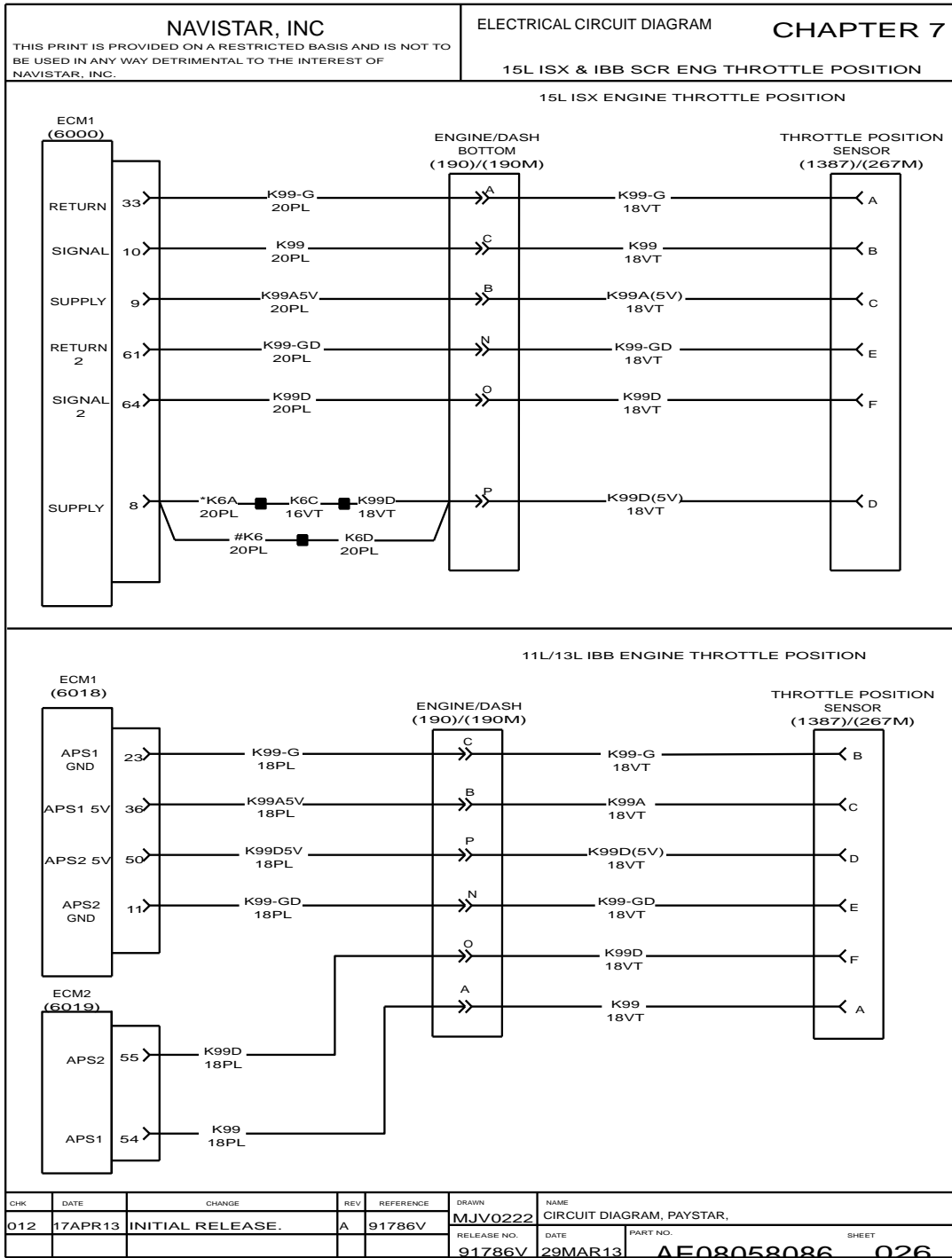


Figure 104 15L ISX & IBB SCR ENG Throttle Position

7.32. DEF & AFTERTREATMENT (SCR ENGINE), P. 27

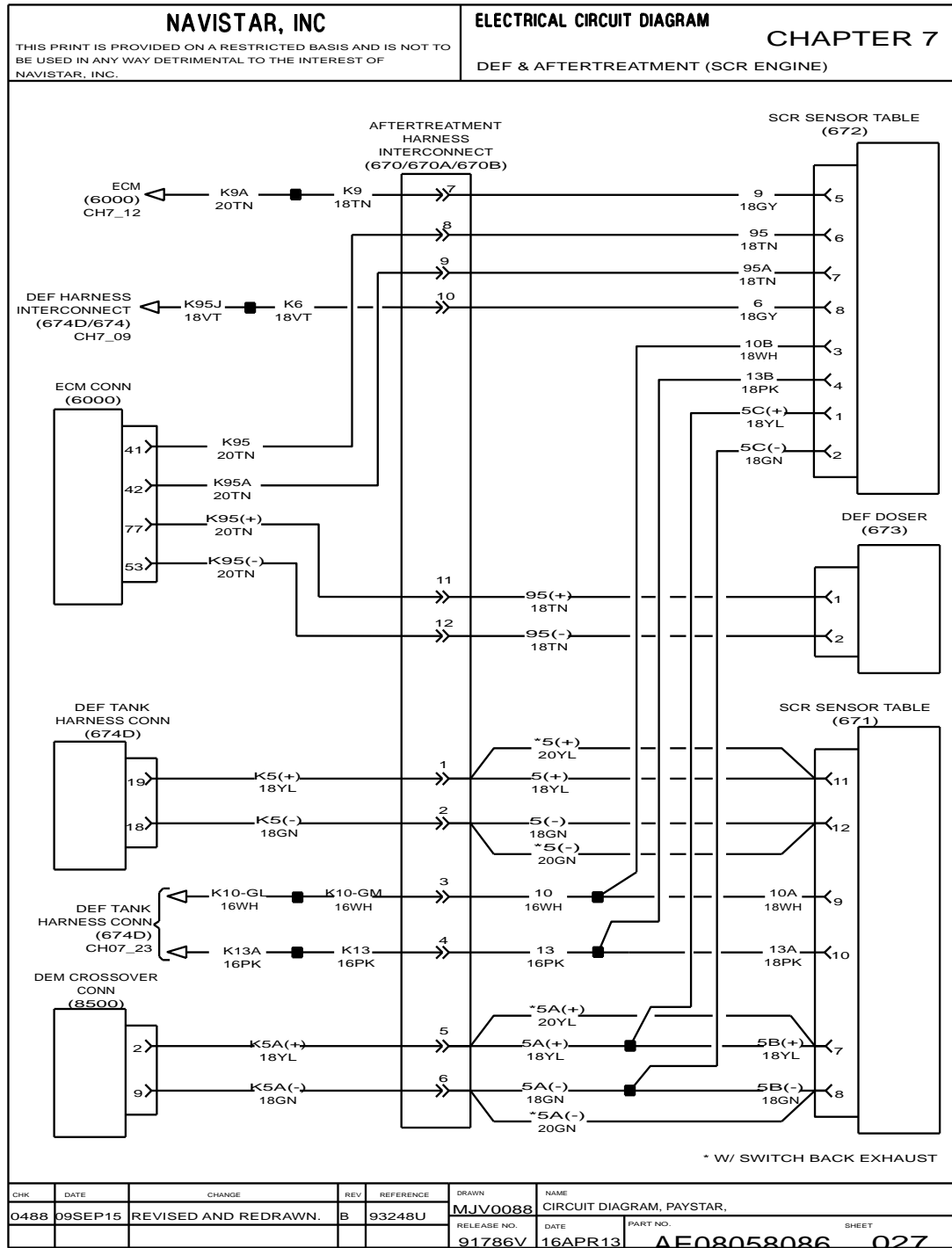


Figure 105 DEF & Aftertreatment (SCR Engine)

CHK	DATE	CHANGE	REV	REFERENCE	DRAWN	NAME		
0488	09SEP15	REVISED AND REDRAWN.	B	93248U	MJV0088	CIRCUIT DIAGRAM, PAYSTAR,		
					RELEASE NO.	DATE	PART NO.	SHEET
					91786V	16APR13	AE08058086	027

7.33. DEF & AFTERTREATMENT (SCR ENGINE) (CONT.), P. 27A

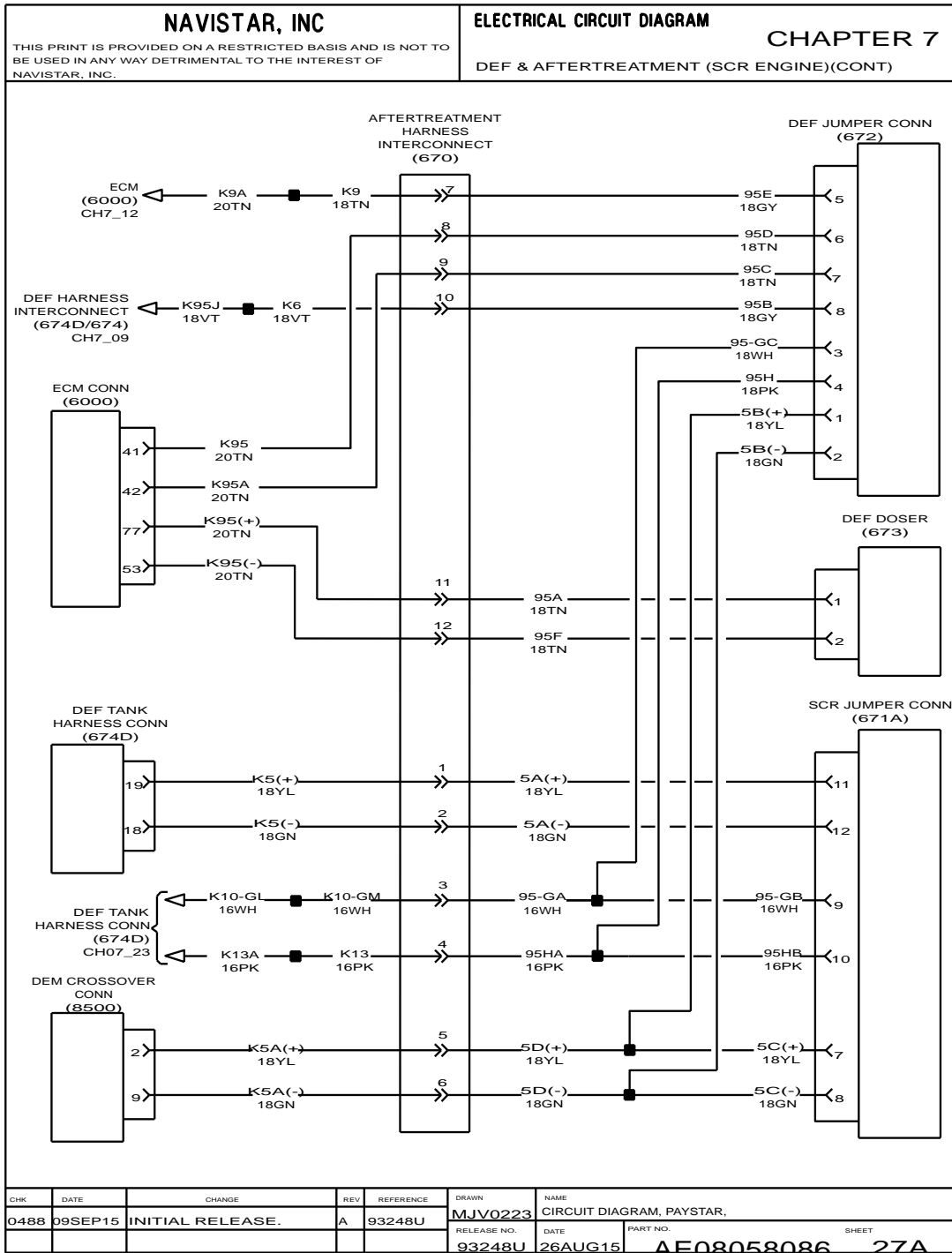


Figure 106 DEF & Aftertreatment (SCR Engine) (Cont.)

7.34. DEF & AFTERTREATMENT (SCR ENGINE) (CONT.), P. 28

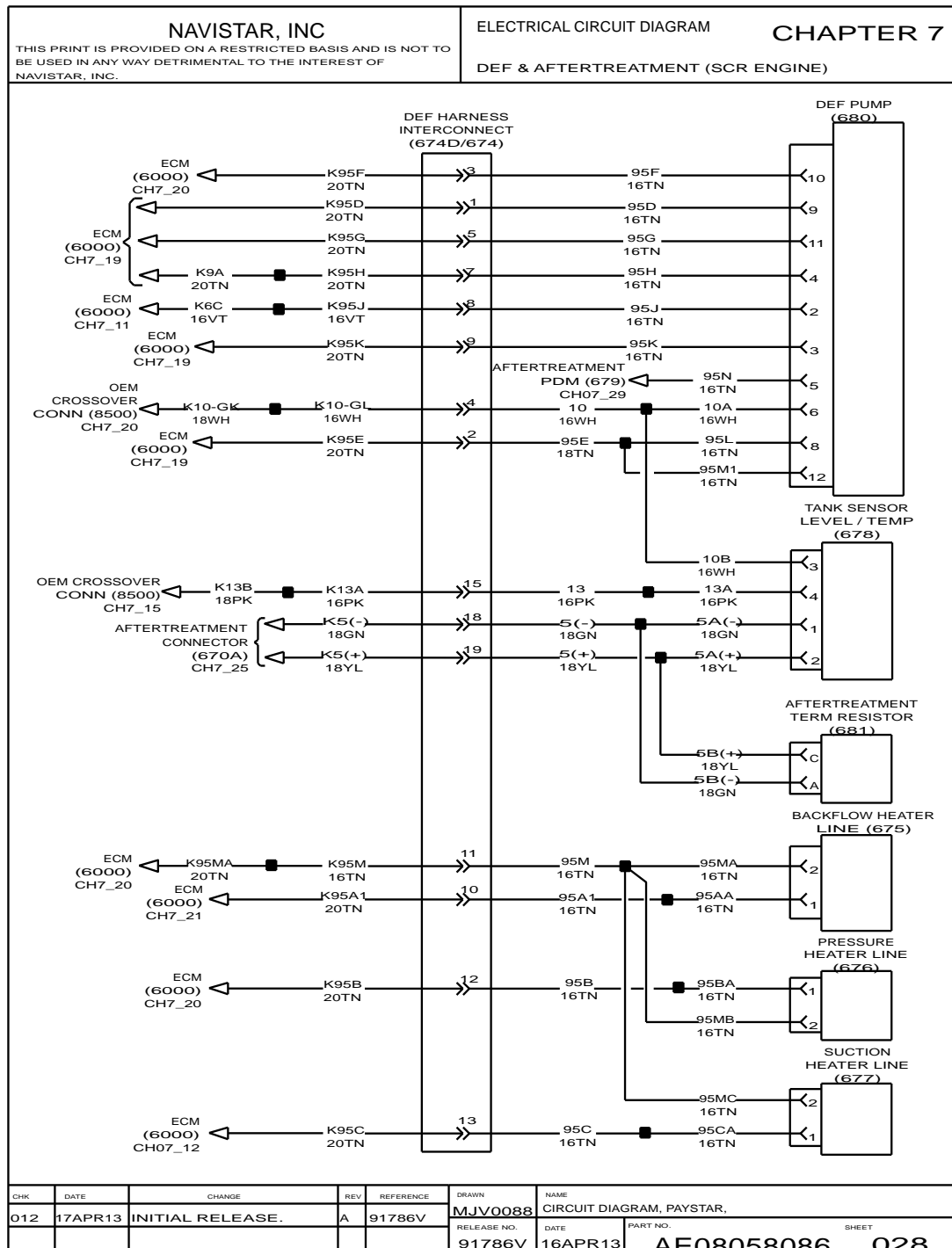


Figure 107 DEF & Aftertreatment (SCR Engine) (Cont.)

7.35. DEF & AFTERTREATMENT (SCR ENGINE) (CONT.), P. 29

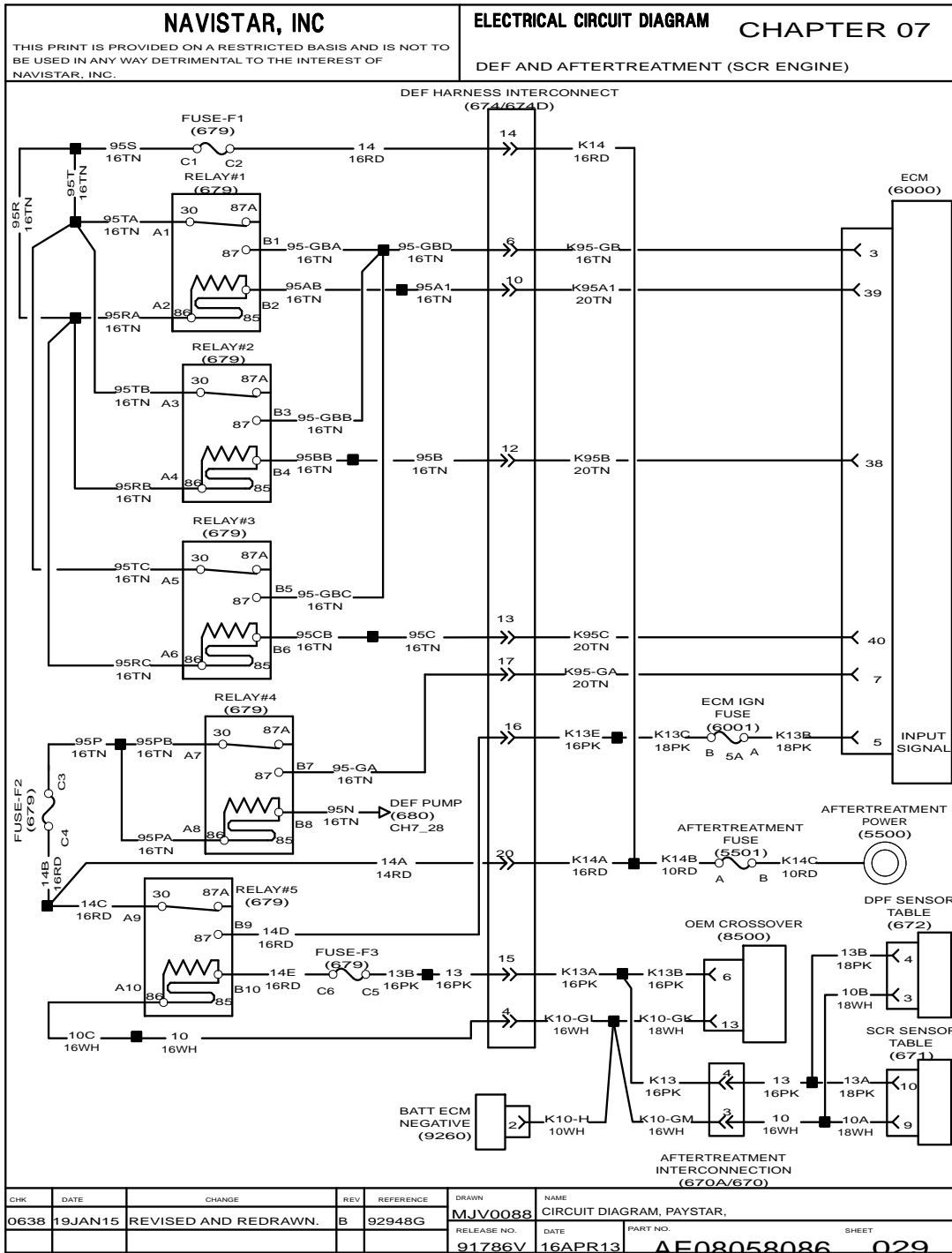


Figure 108 DEF & Aftertreatment (SCR Engine) (Cont.)

## GAUGES AND WARNING LIGHTS (CHAPTER 8)

### 8.1. LOW FUEL LEVEL WARNING, LOW AIR PRESSURE WARNING LIGHTS, P. 1

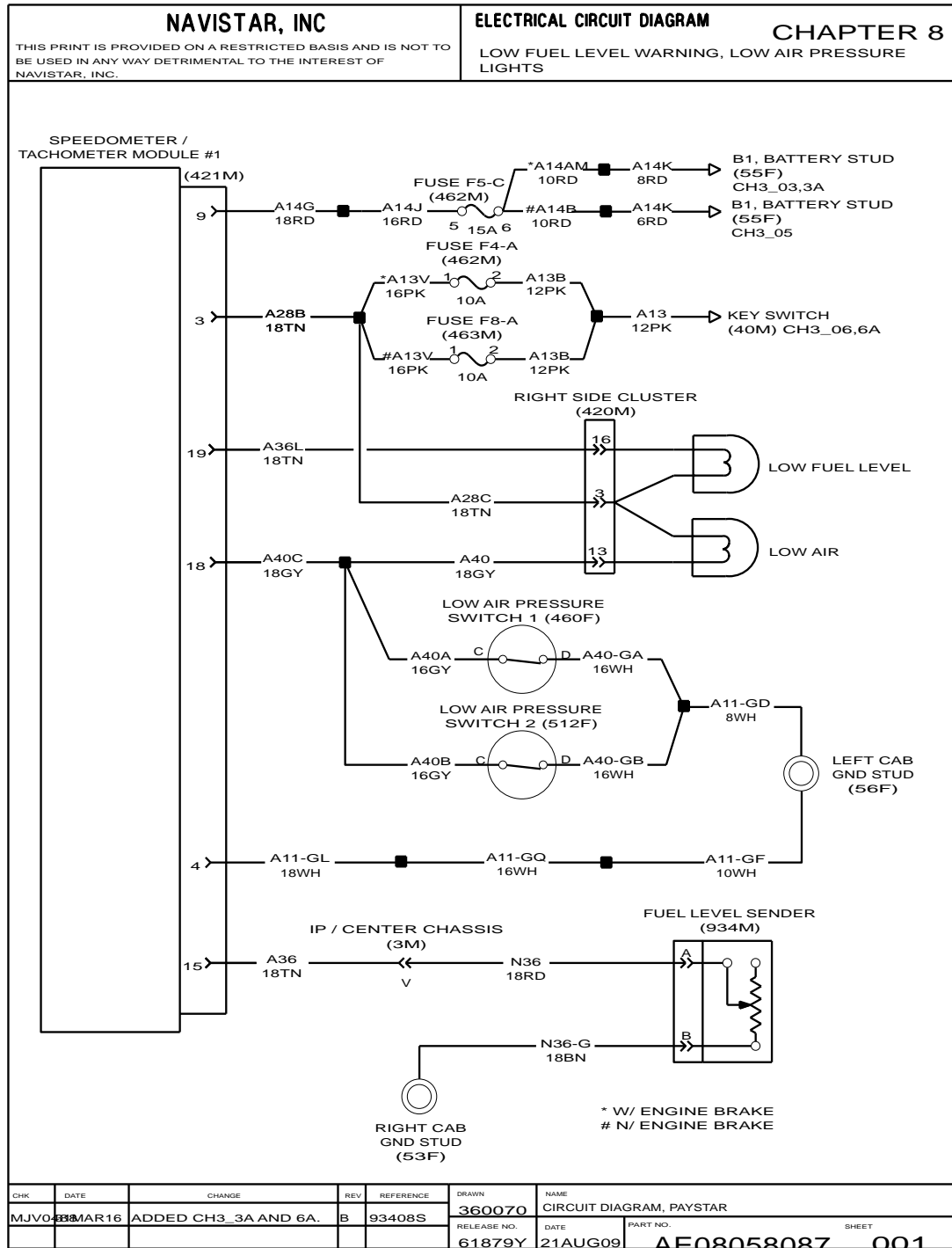


Figure 109 Low Fuel Level Warning, Low Air Pressure Warning Lights

8.2. ENGINE OIL PRESSURE, ENGINE WATER TEMPERATURE WARNING LIGHTS, ENGINE AMBIENT AIR TEMP, P. 2

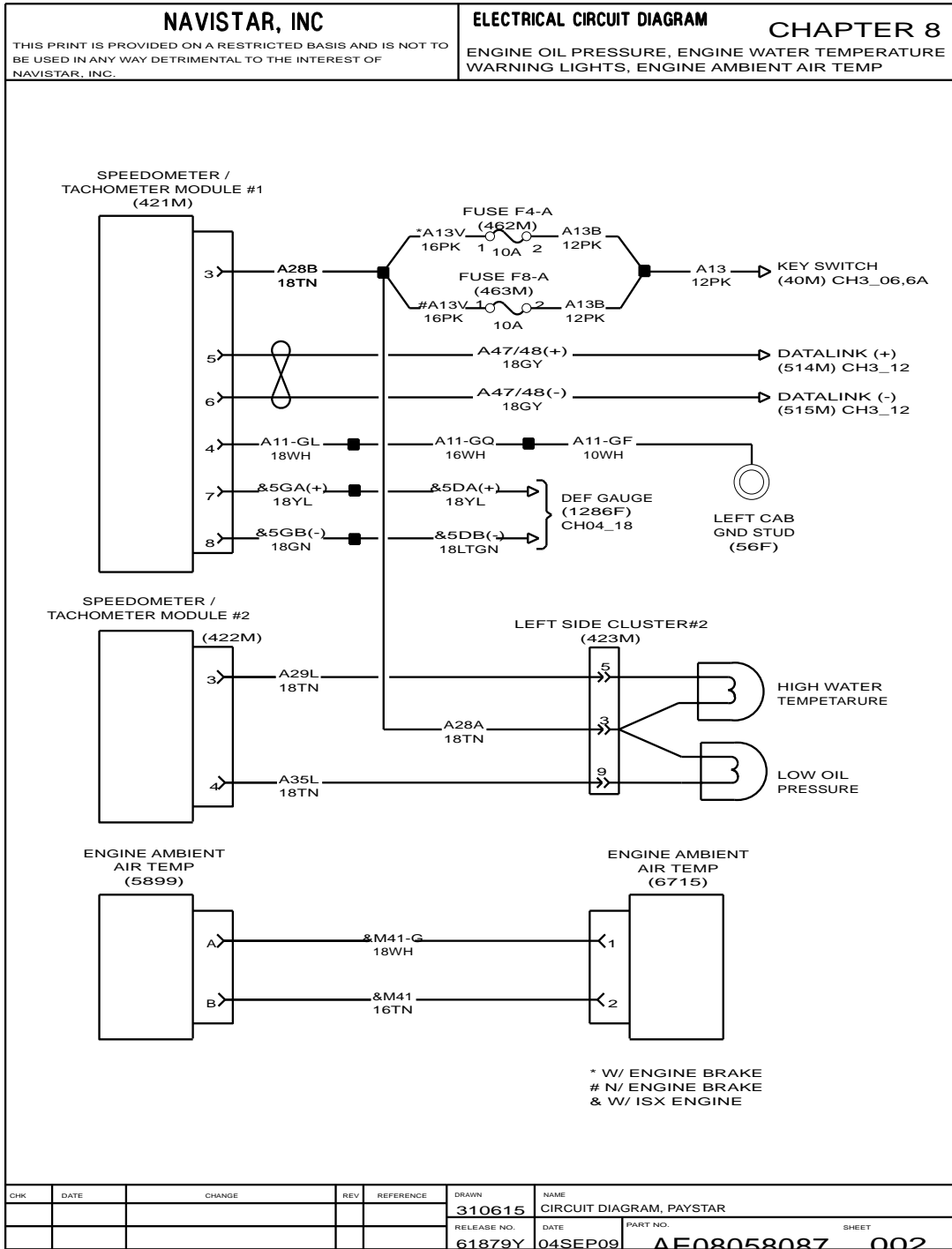


Figure 110 Engine Oil Pressure, Engine Water Temperature Warning Lights, Engine Ambient Air Temp



8.3. POWER DIVIDER LOCK (PDL) WARNING LIGHT AND BUZZER, IBB WAIT TO START LIGHT, P. 3

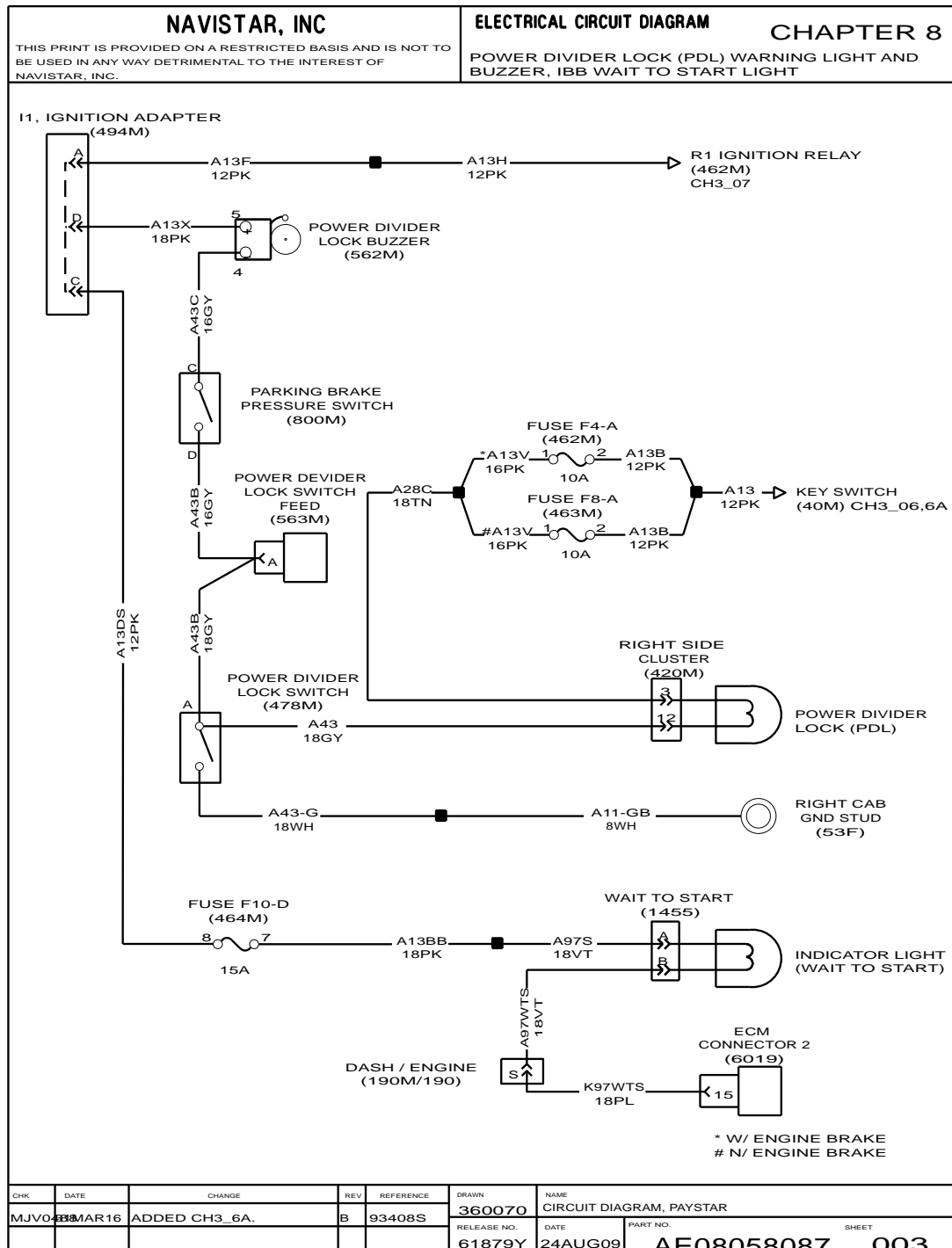


Figure 111 Power Divider Lock (PDL) Warning Light and Buzzer, IBB Wait To Start Light

8.4. AIR SUSPENSION RELEASE WARNING LIGHT, P. 4

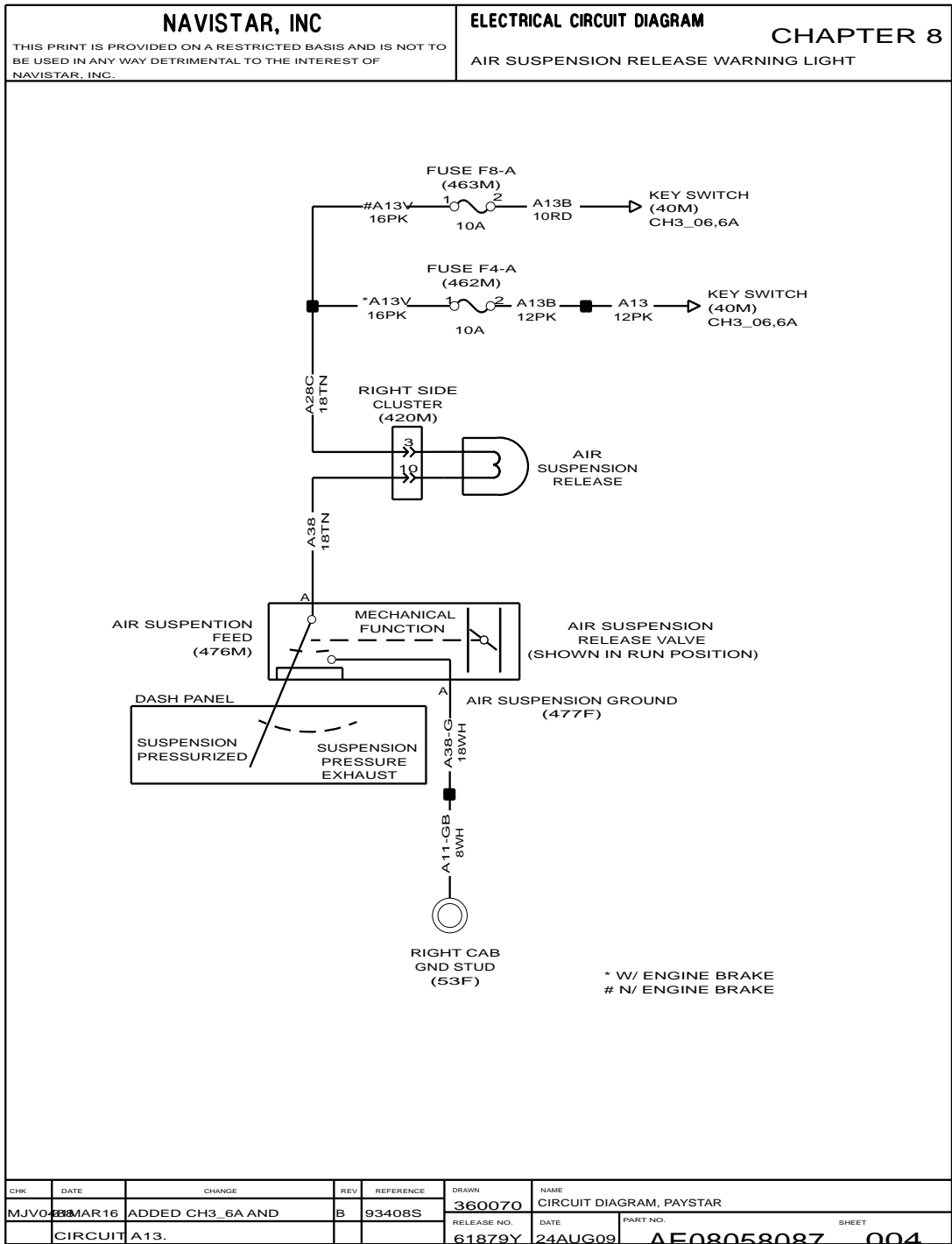


Figure 112 Air Suspension Release Warning Light

8.5. TRANSMISSION OIL TEMPERATURE GAUGE, AXLE FORWARD-REAR AND REAR-REAR TEMPERATURE GAUGE, P. 5

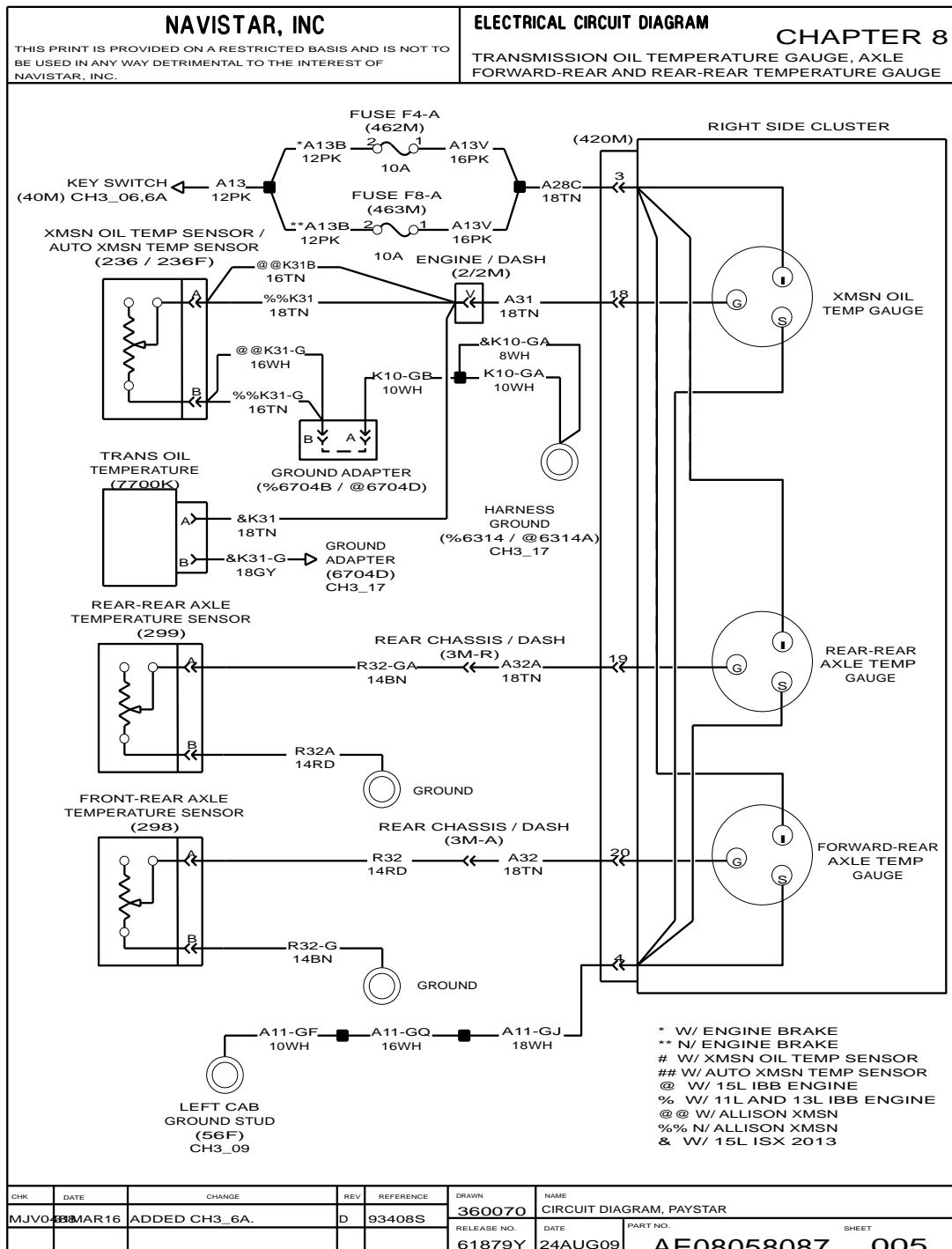


Figure 113 Transmission Oil Temperature Gauge, Axle Forward-Rear and Rear-Rear Temperature Gauge

8.6. MANIFOLD PRESSURE GAUGE, P. 6

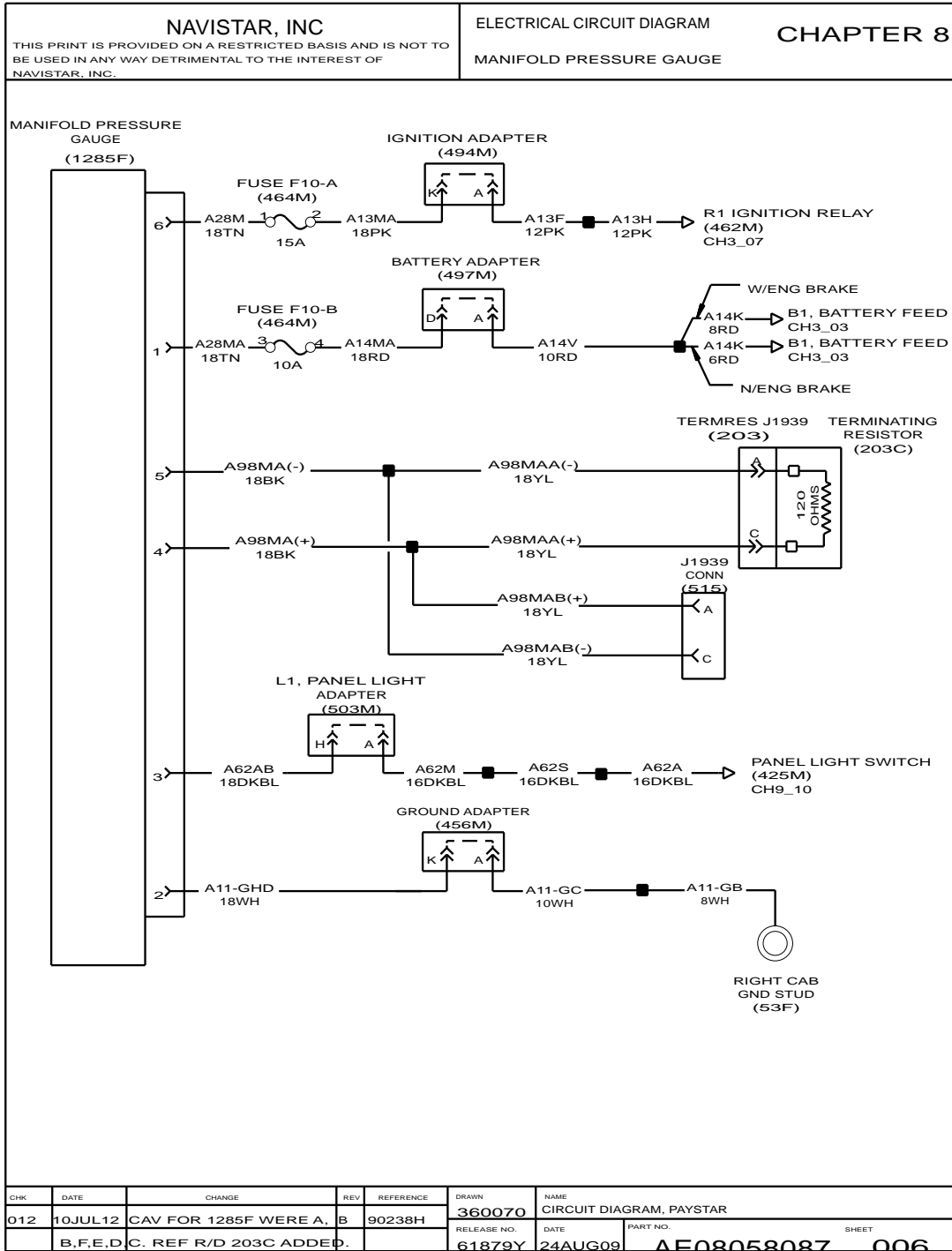


Figure 114 Manifold Pressure Gauge

8.7. PYROMETER GAUGE, P. 7

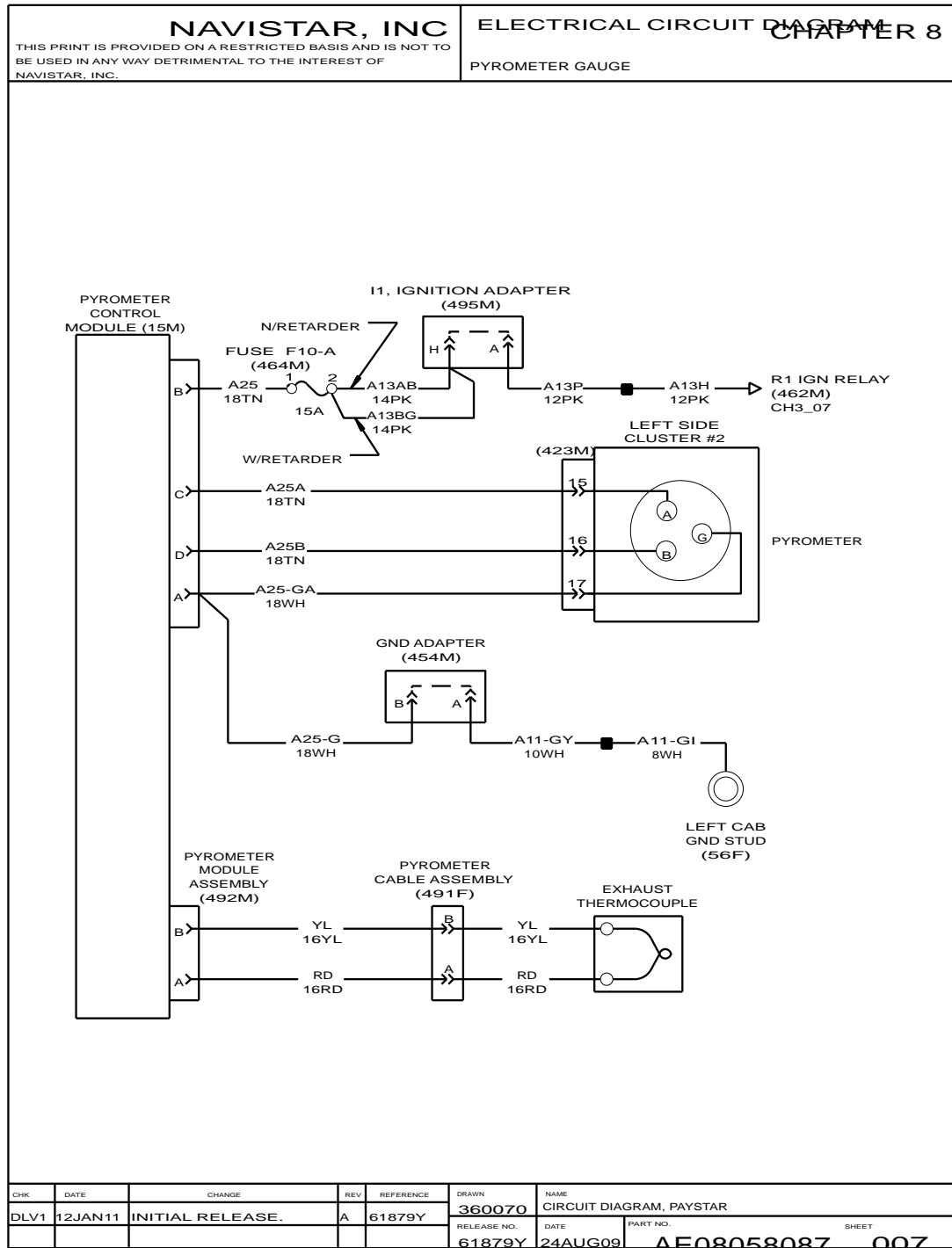


Figure 115 Pyrometer Gauge

8.8. VOLTMETER AND FUEL LEVEL GAUGE, P. 8

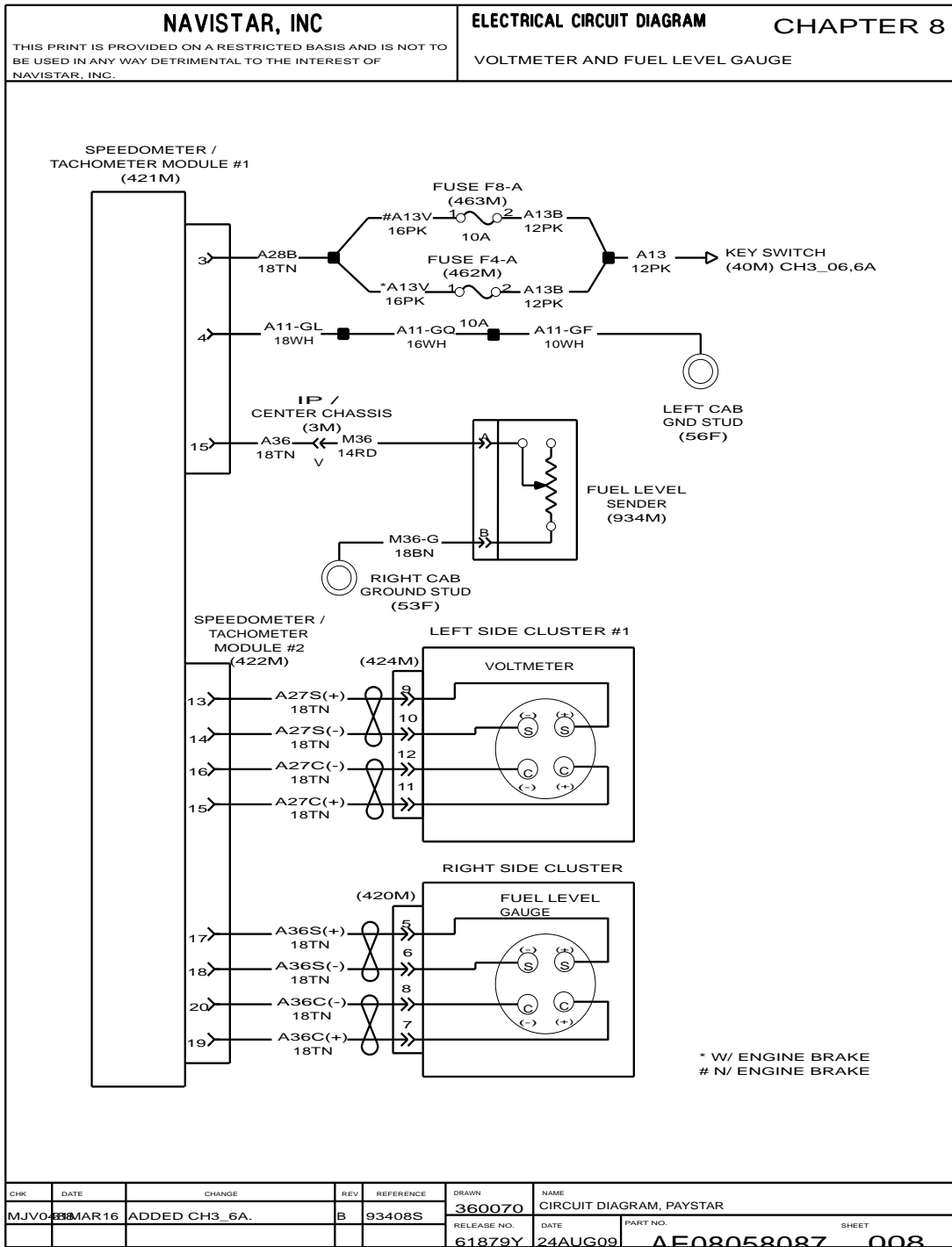


Figure 116 Voltmeter and Fuel Level Gauge

8.9. ENGINE WATER TEMPERATURE, ENGINE OIL PRESSURE, SPEEDOMETER AND TACHOMETER GAUGE, P. 9

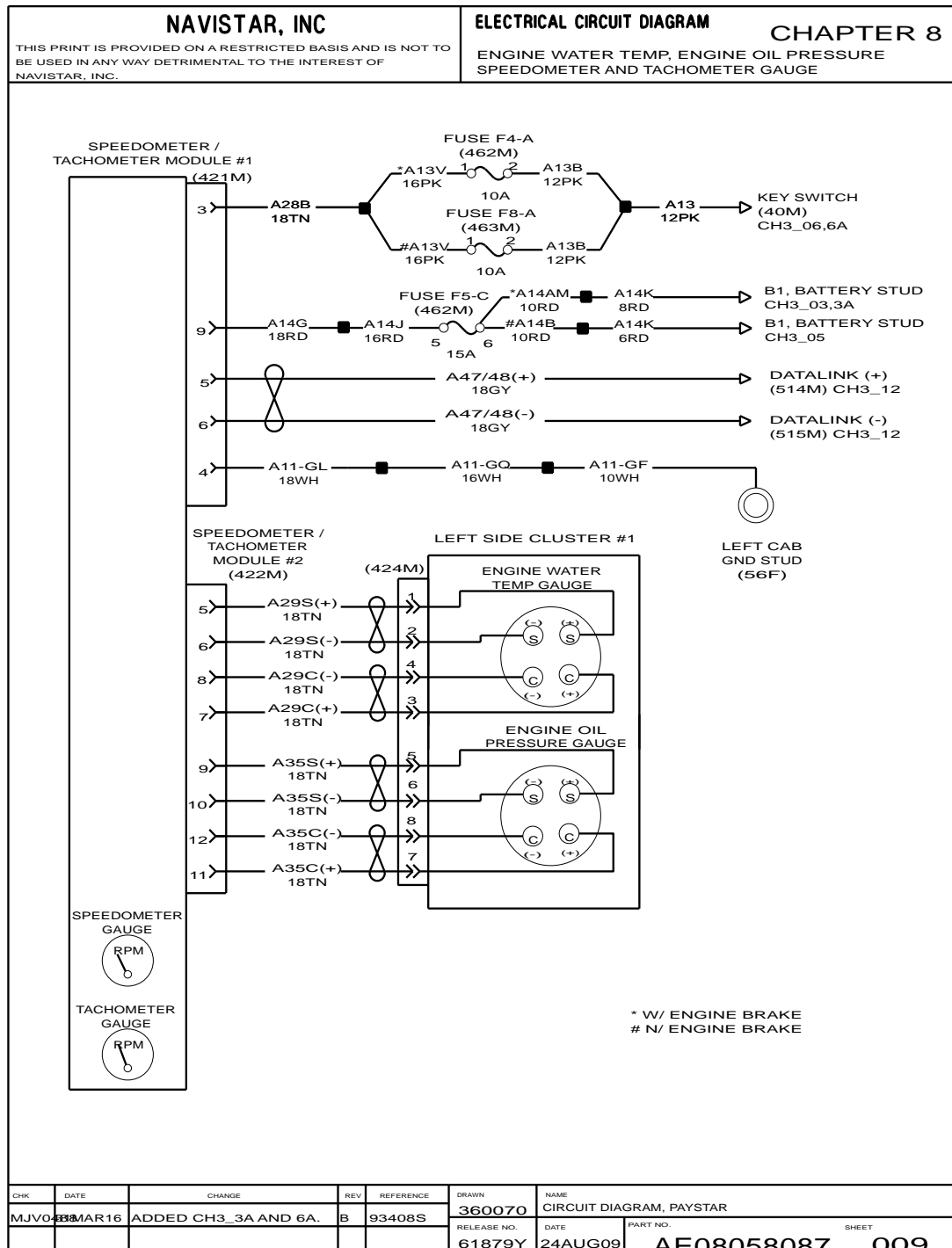


Figure 117 Engine Water Temperature, Engine Oil Pressure, Speedometer and Tachometer Gauge

8.10. ETHER START, P. 10

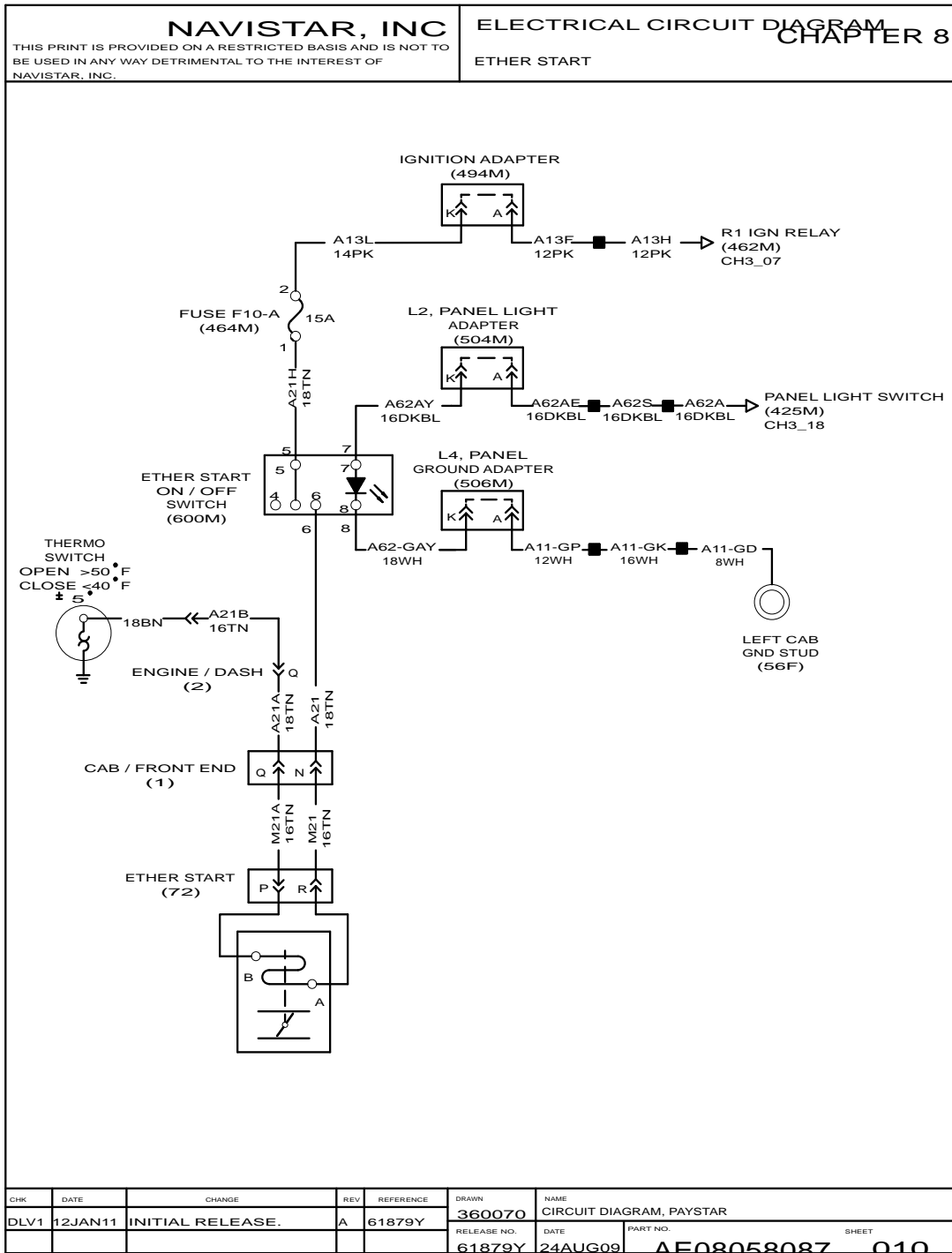


Figure 118 Ether Start



8.11. RED STOP LAMP BUZZER SYSTEM, P. 11

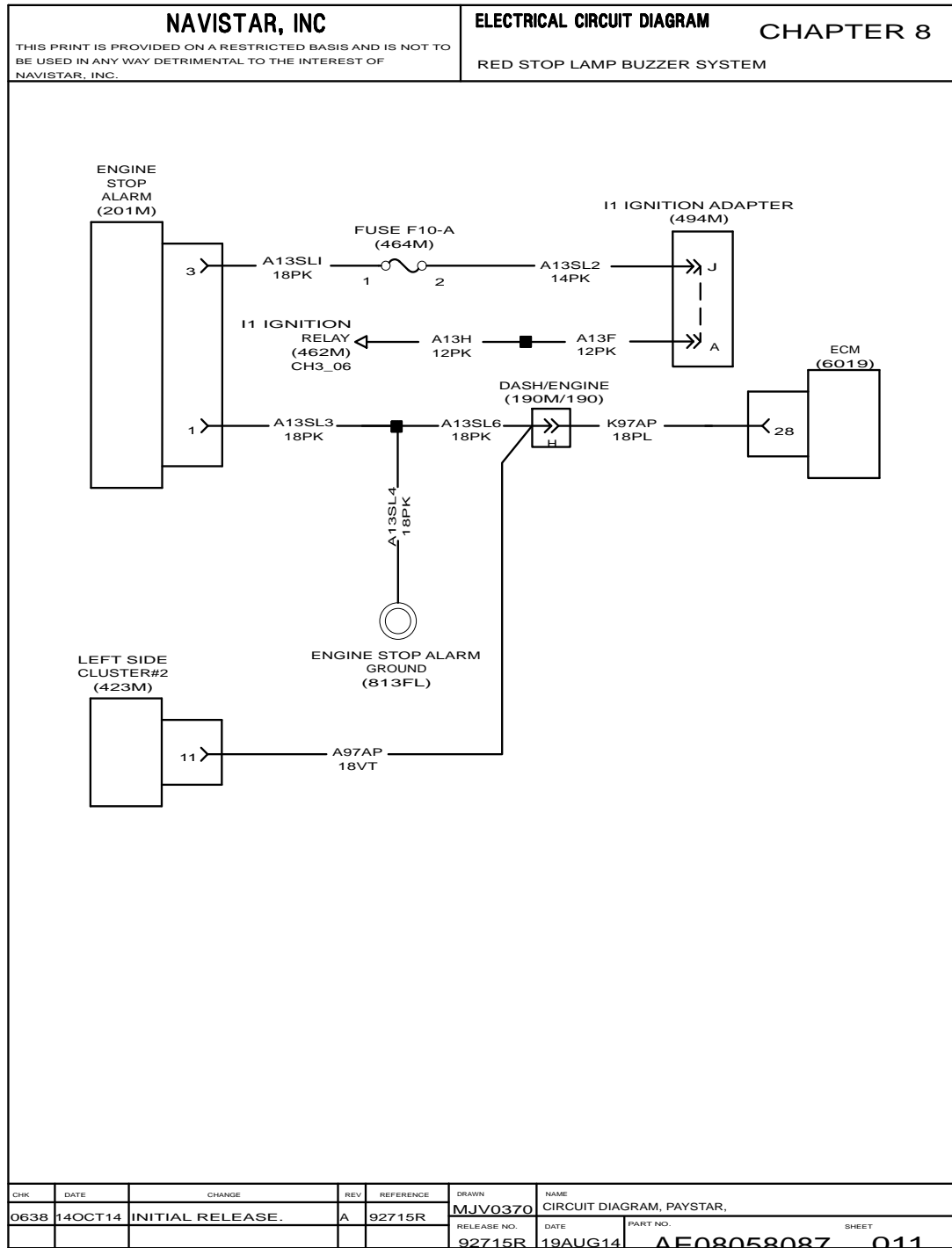
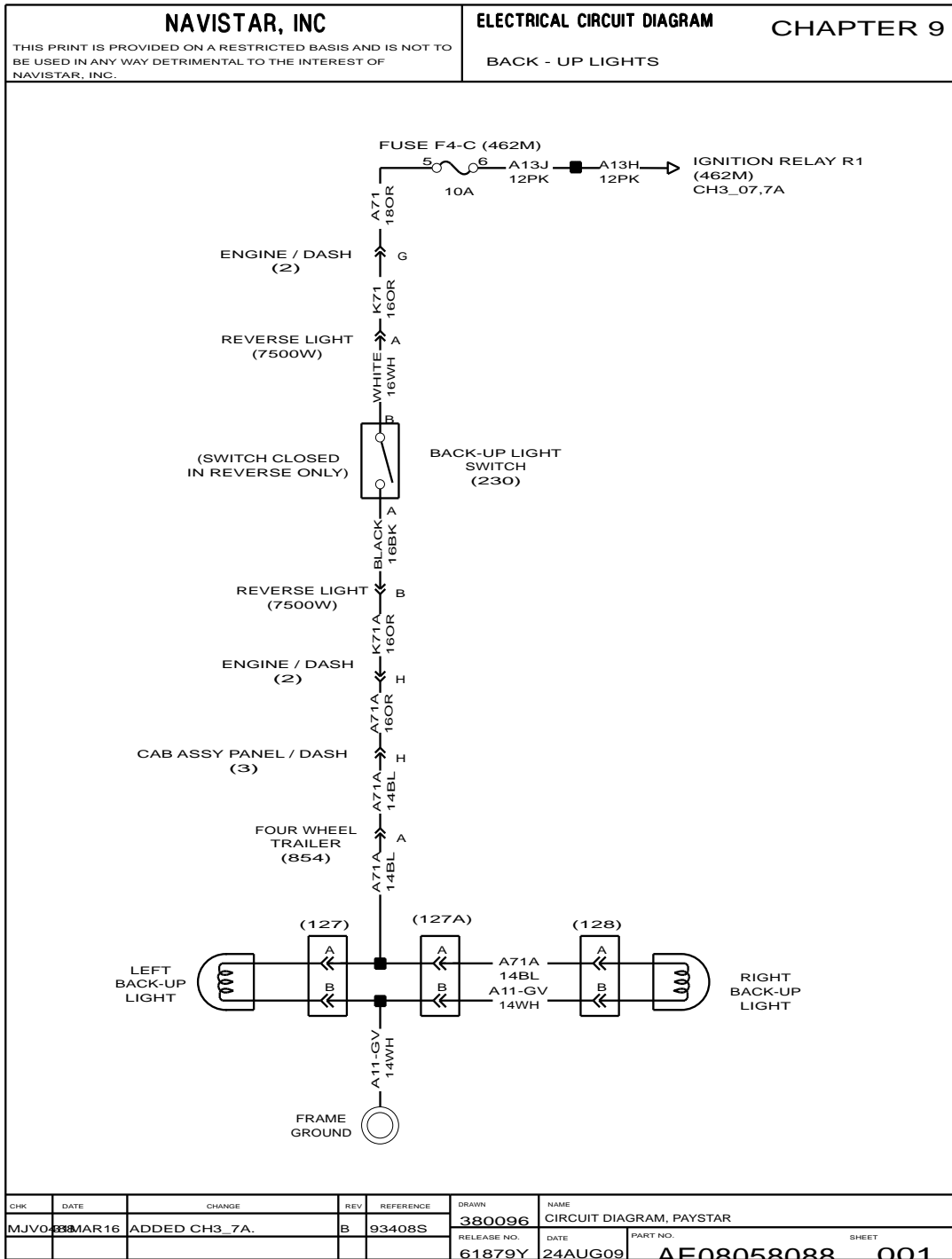


Figure 119 Red Stop Lamp Buzzer System

CHK	DATE	CHANGE	REV	REFERENCE	DRAWN	NAME
0638	14OCT14	INITIAL RELEASE.	A	92715R	MJV0370	CIRCUIT DIAGRAM, PAYSTAR,
					RELEASE NO.	DATE
					92715R	19AUG14
					PART NO.	SHEET
					AE08058087	011

# LIGHTING SYSTEM (CHAPTER 9)

## 9.1. BACKUP LIGHTS, P. 1



9.2. CAB AND TRAILER LIGHT SWITCH AND RELAY, P. 2

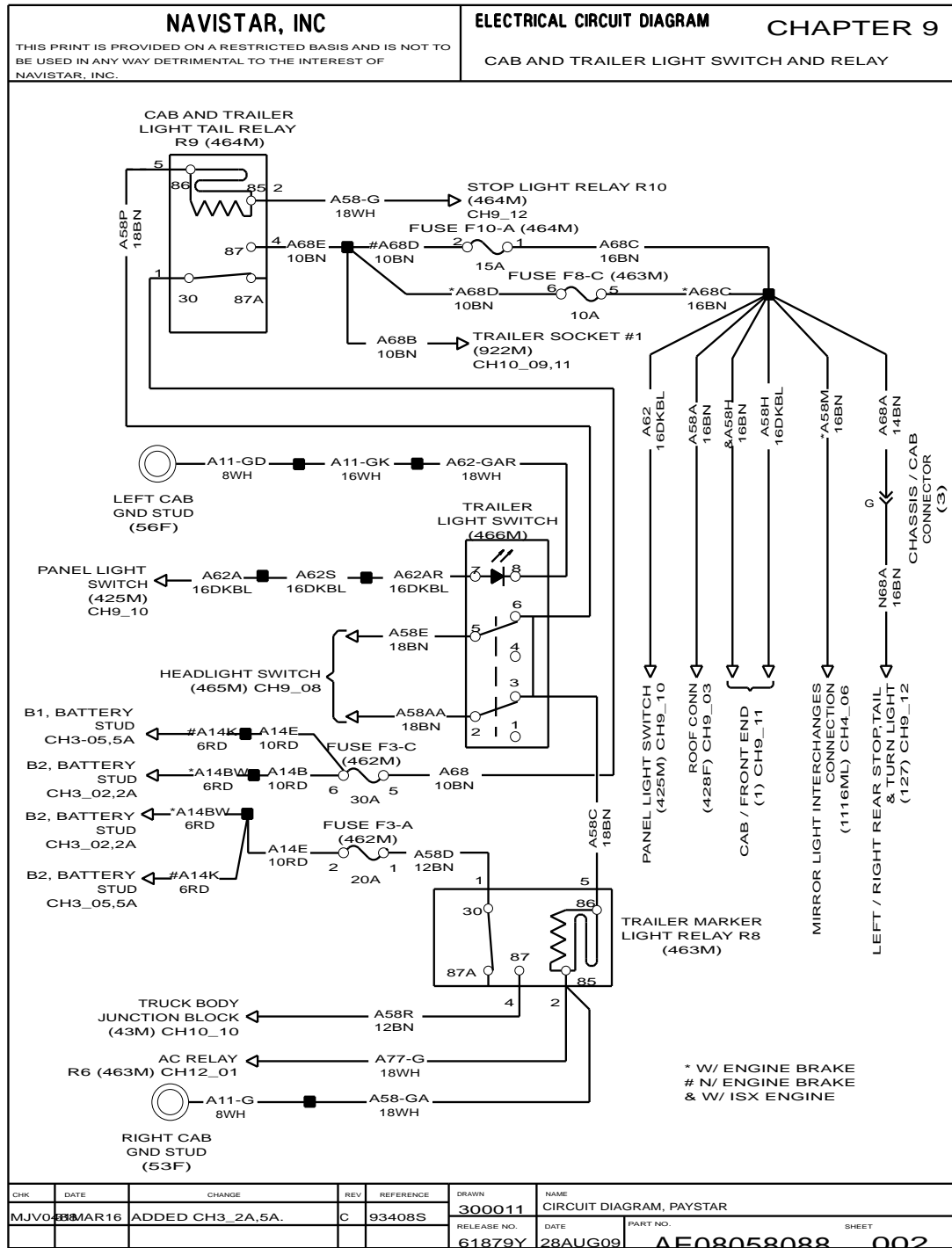


Figure 121 Cab and Trailer Light Switch and Relay

9.3. CAB CLEARANCE LIGHTS, P. 3

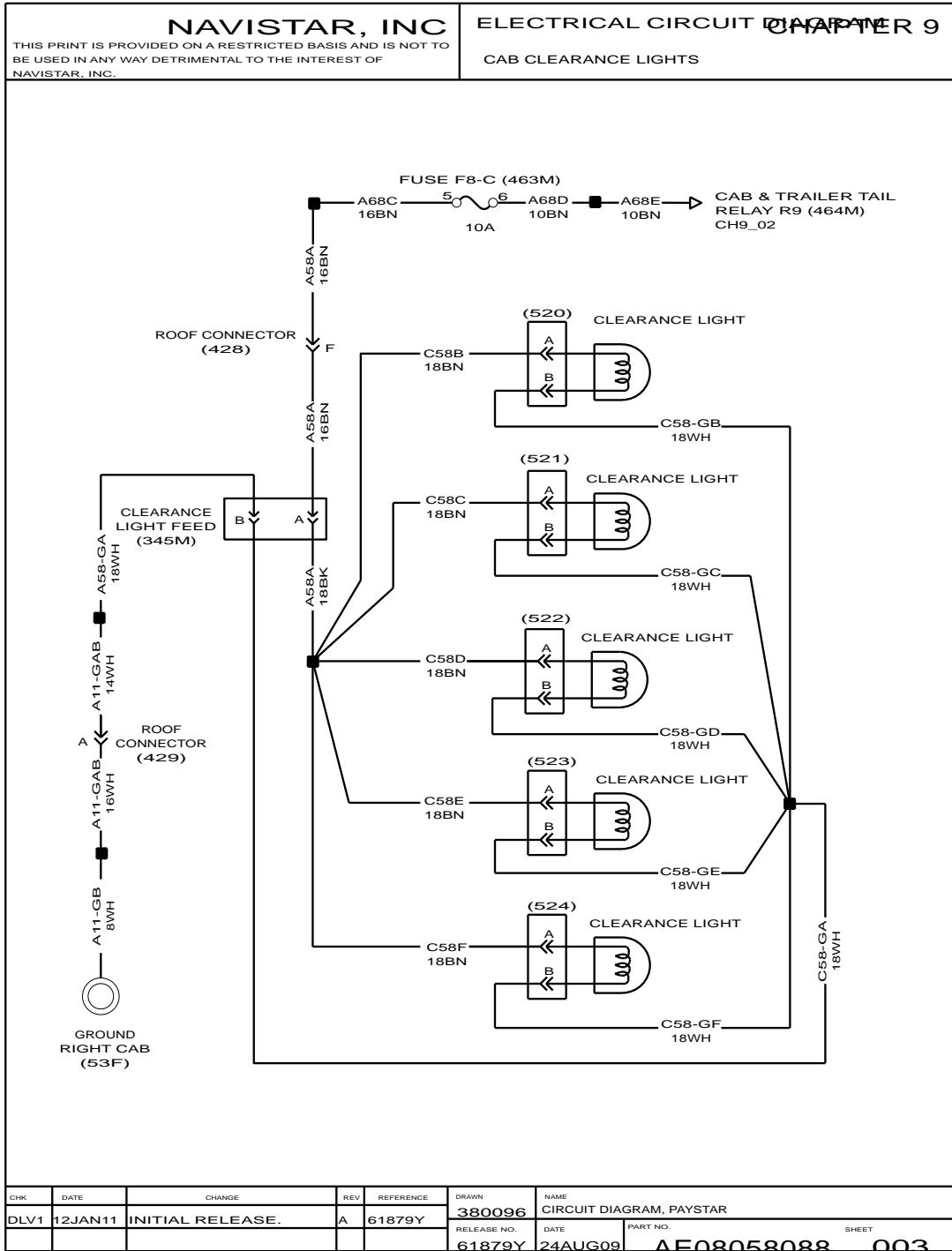


Figure 122 Cab Clearance Lights

9.4. WORK LIGHT WITHOUT SLEEPER, P. 4

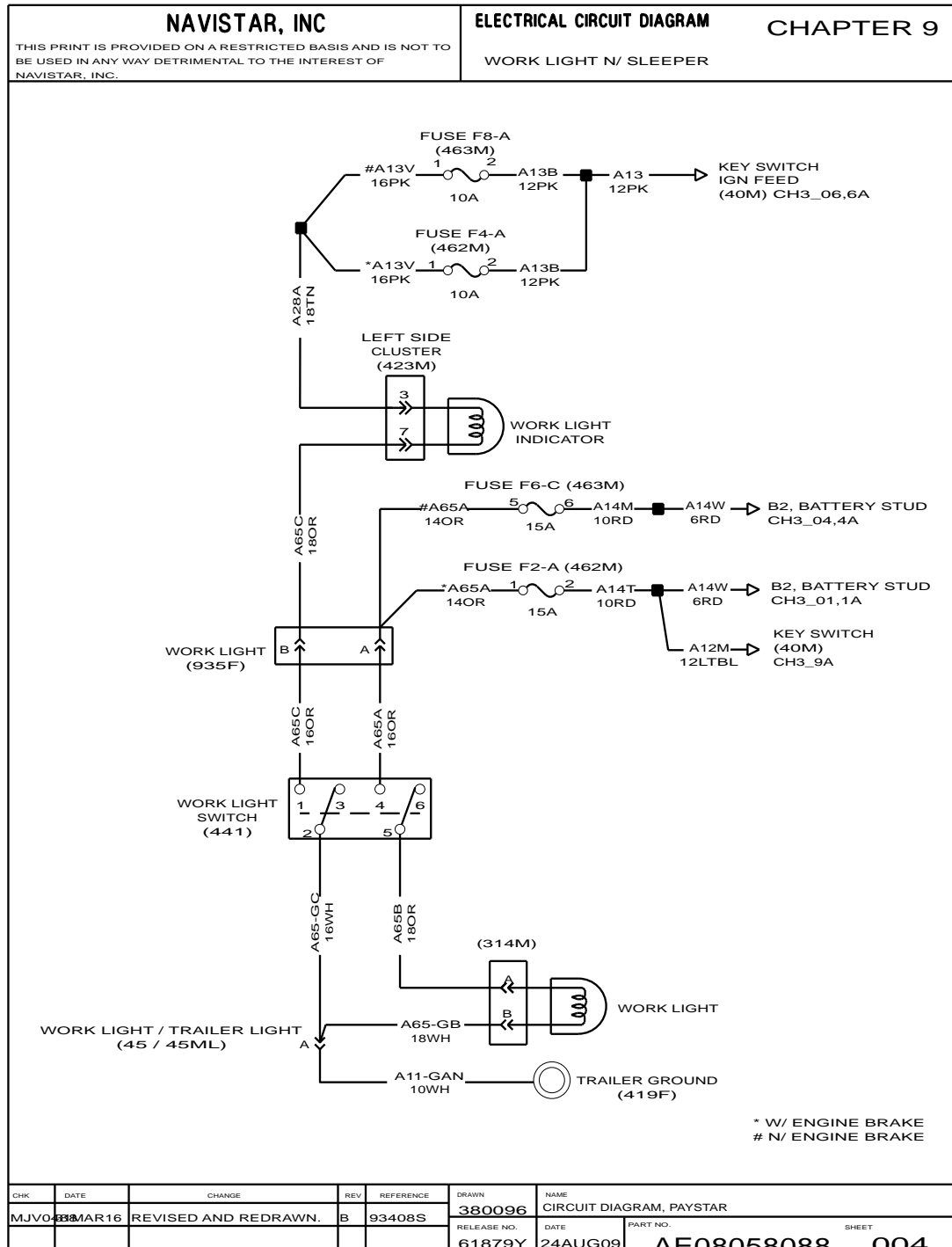


Figure 123 Work Light without Sleeper

9.5. CAB DOME, READING AND COURTESY LIGHTS, P. 5

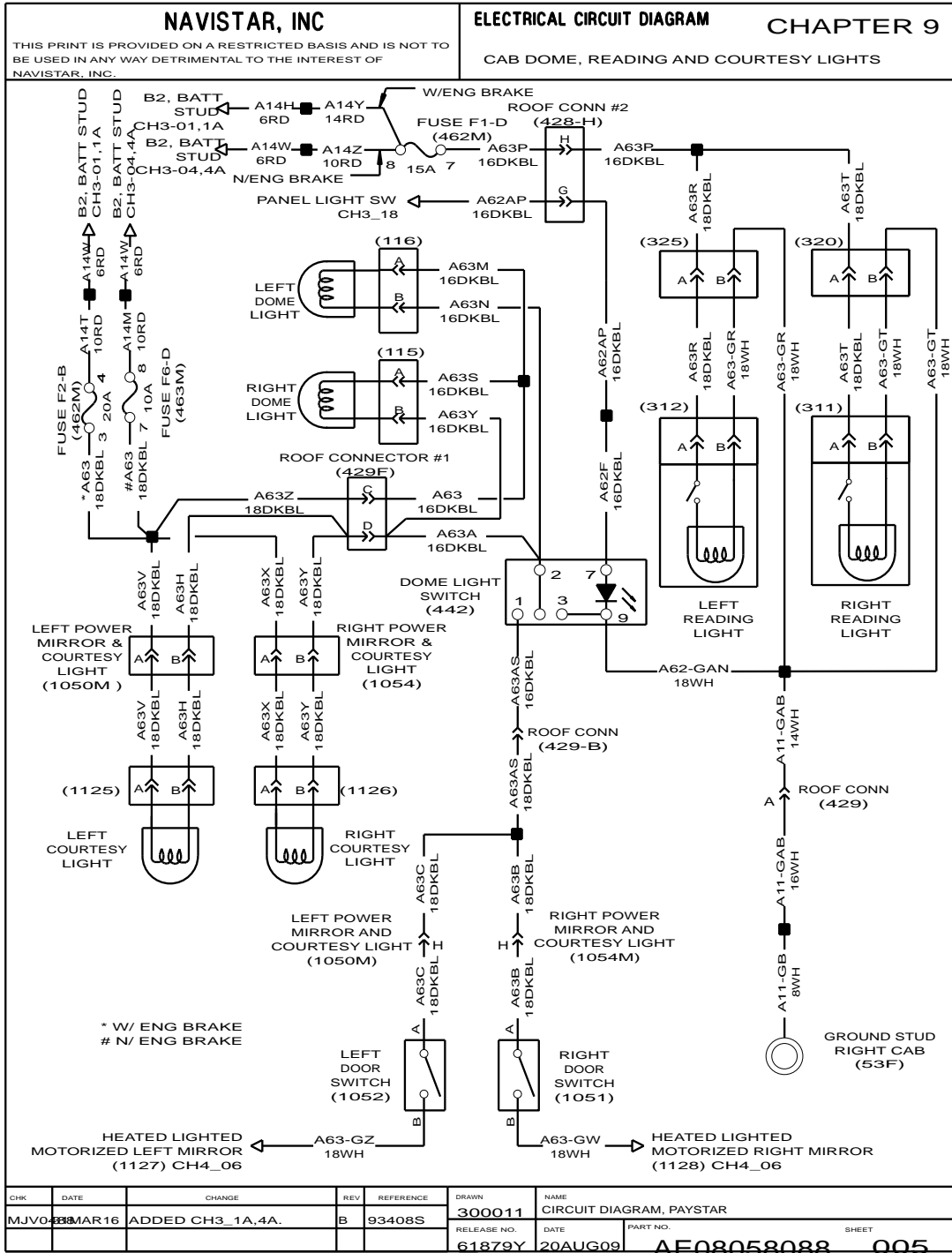


Figure 124 Cab Dome, Reading and Courtesy Lights

9.6. DAYTIME RUNNING LIGHTS, P. 6

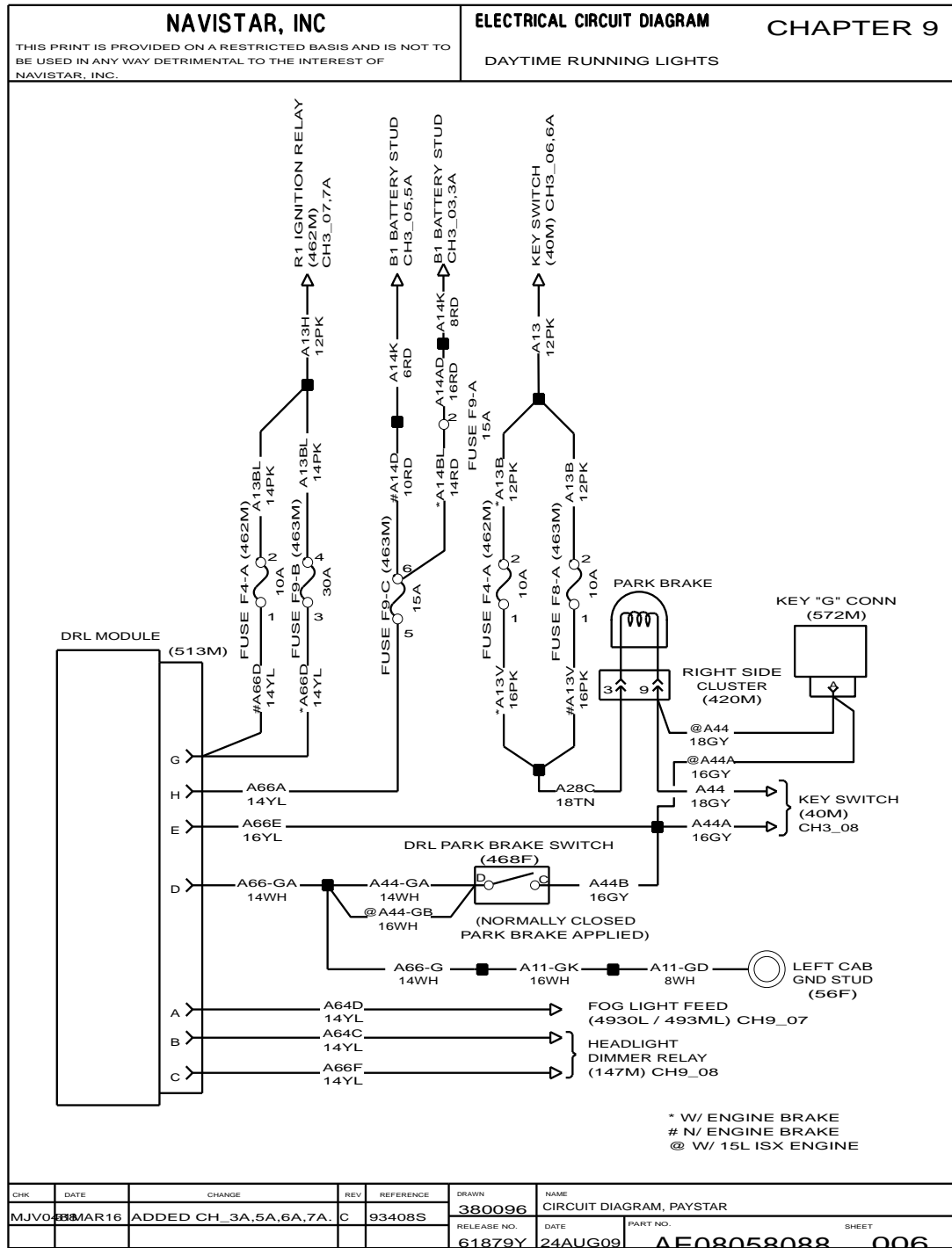


Figure 125 Daytime Running Lights

9.7. FOG LIGHTS, P. 7

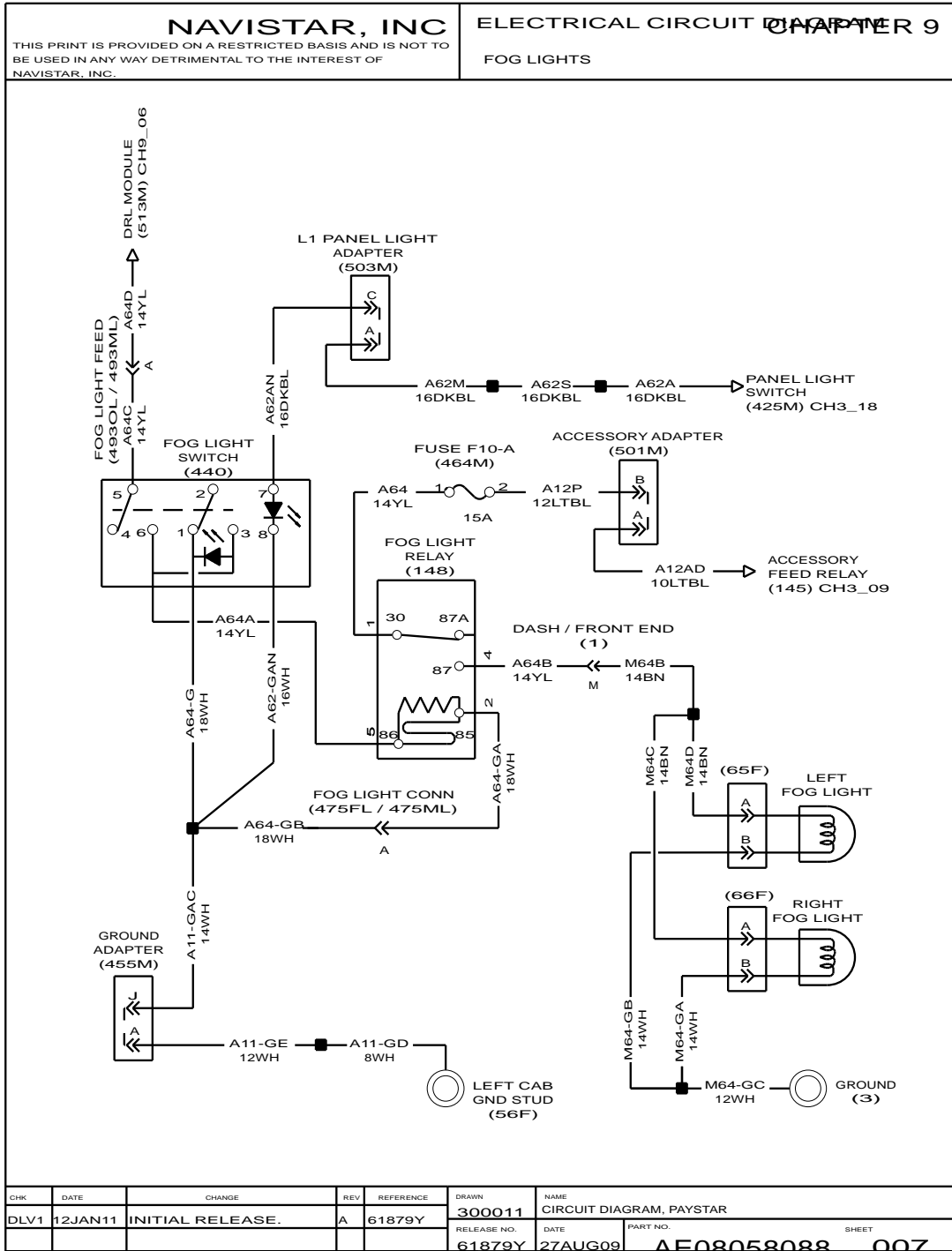


Figure 126 Fog Lights



9.8. HEADLIGHT SWITCH AND DIMMER SWITCH, P. 8

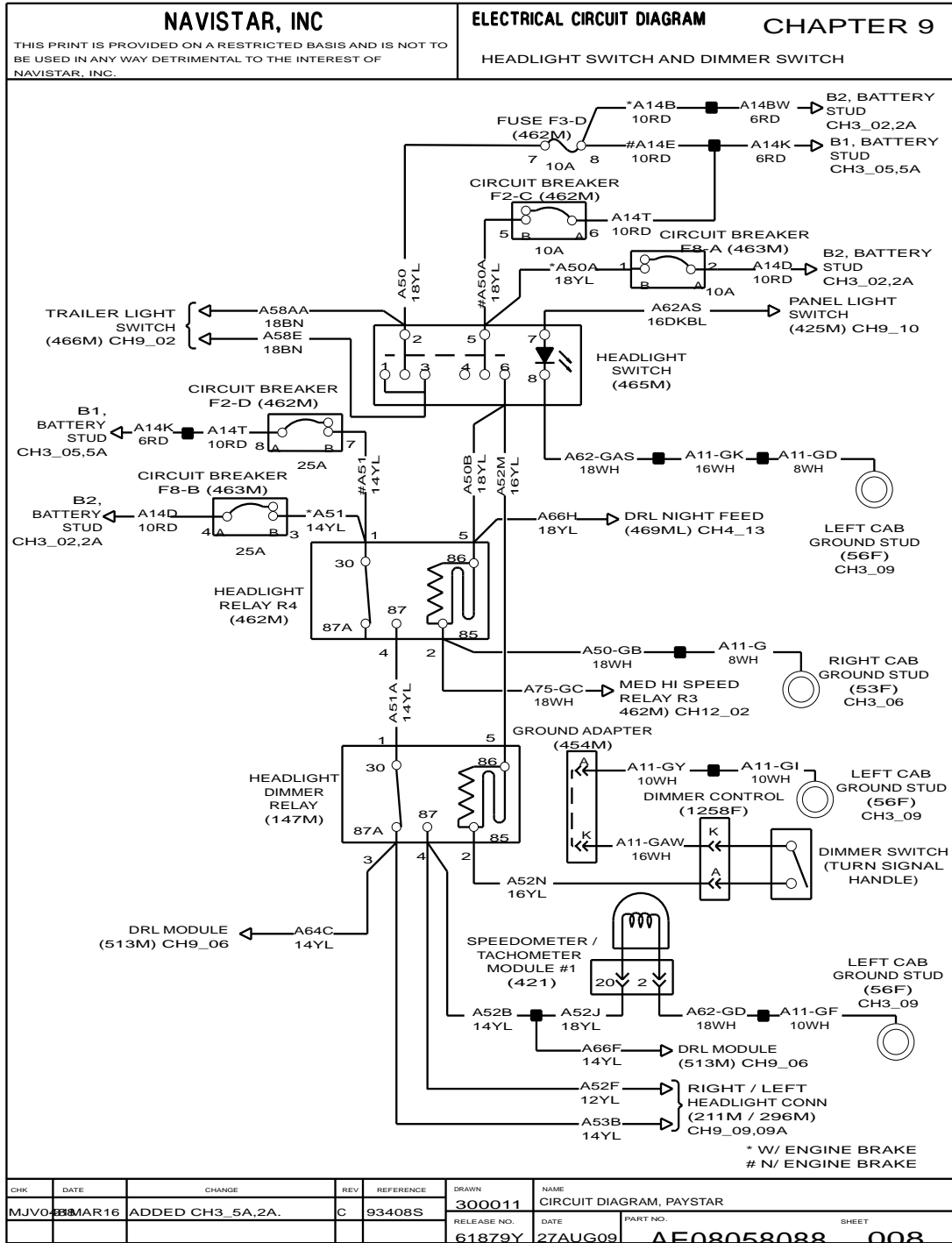


Figure 127 Headlight Switch and Dimmer Switch

9.9. HEADLIGHTS, P. 9

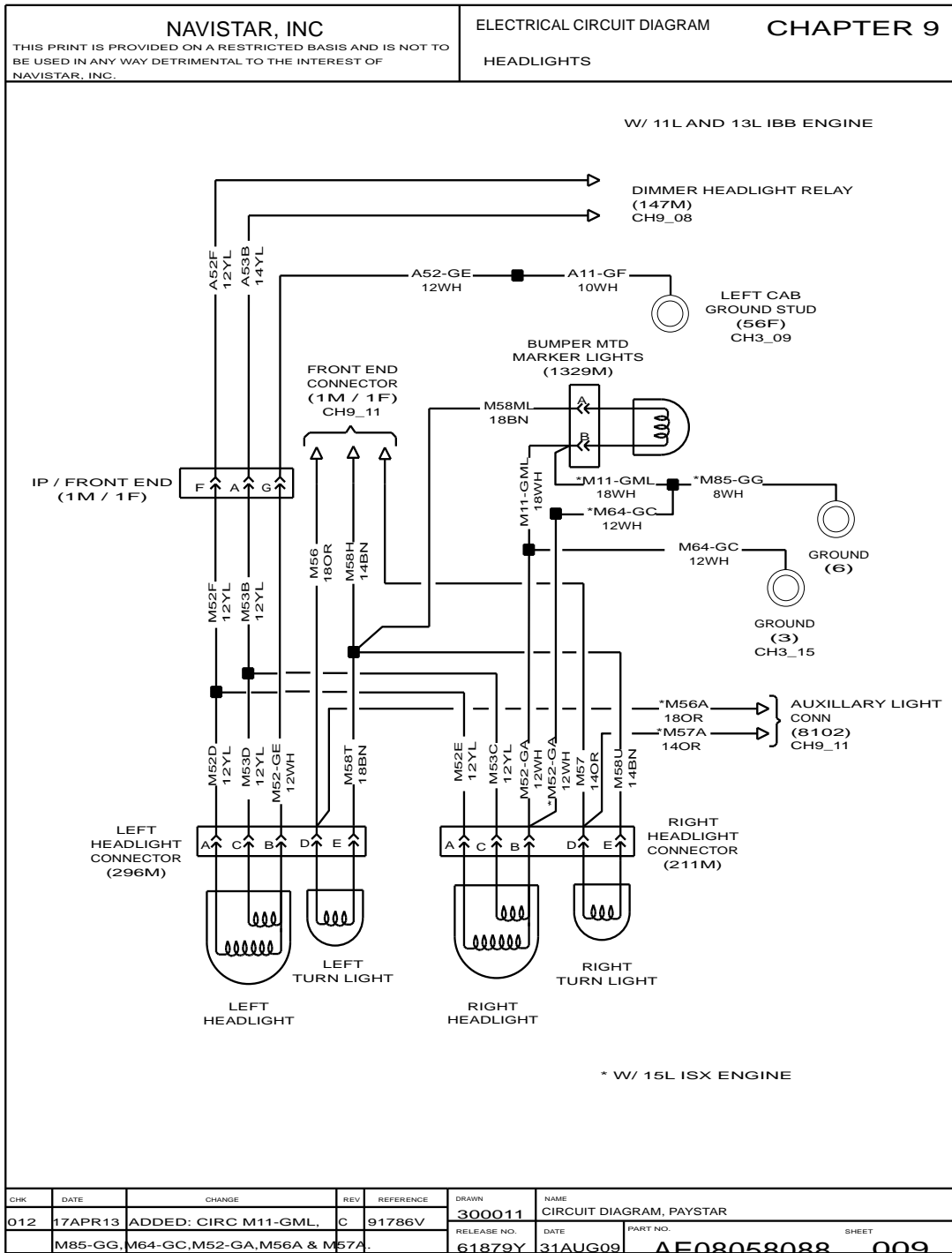


Figure 128 Headlights

9.10. HEADLIGHTS (CONT.), P. 9A

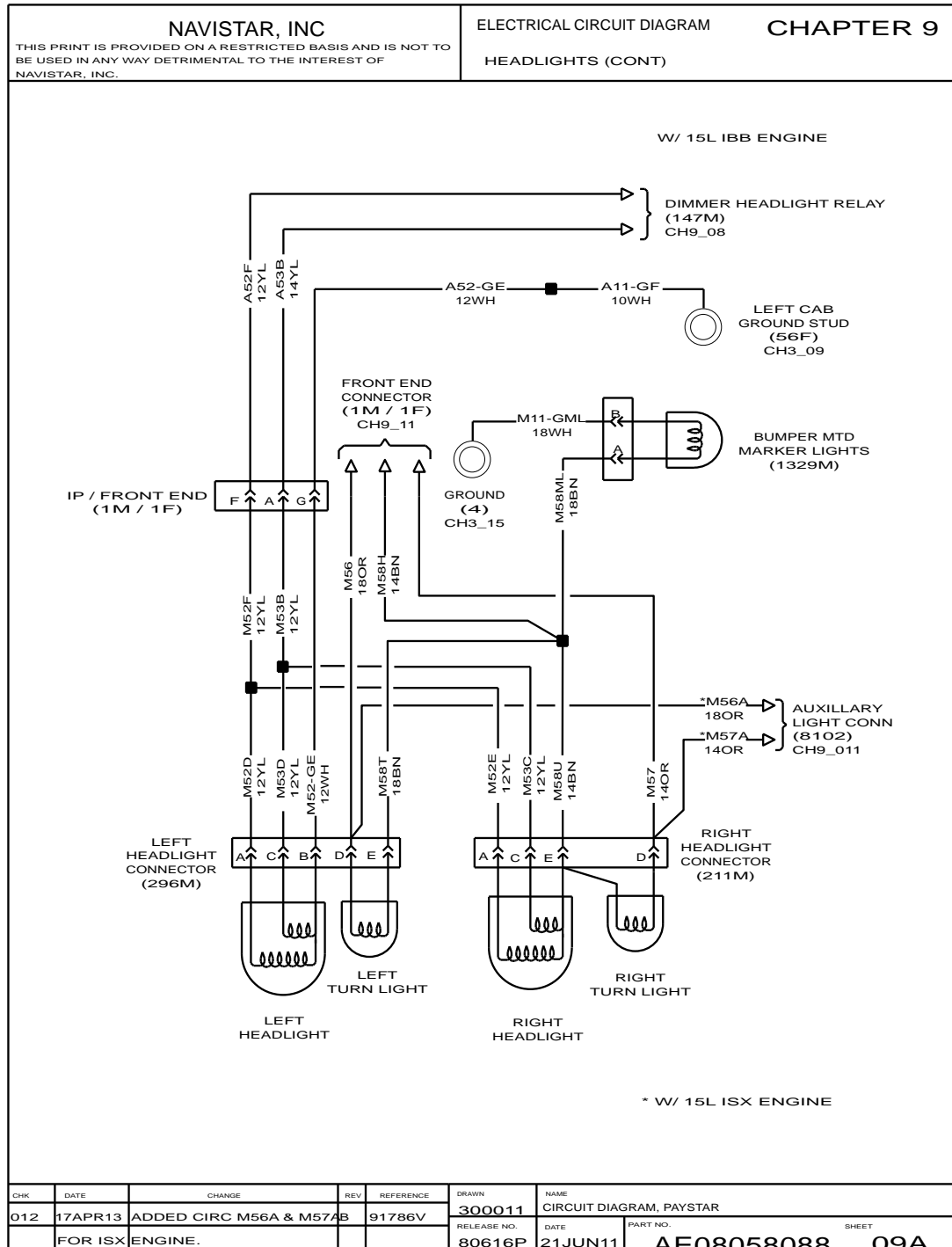


Figure 129 Headlights (Cont.)

9.11. PANEL LIGHTS, P. 10

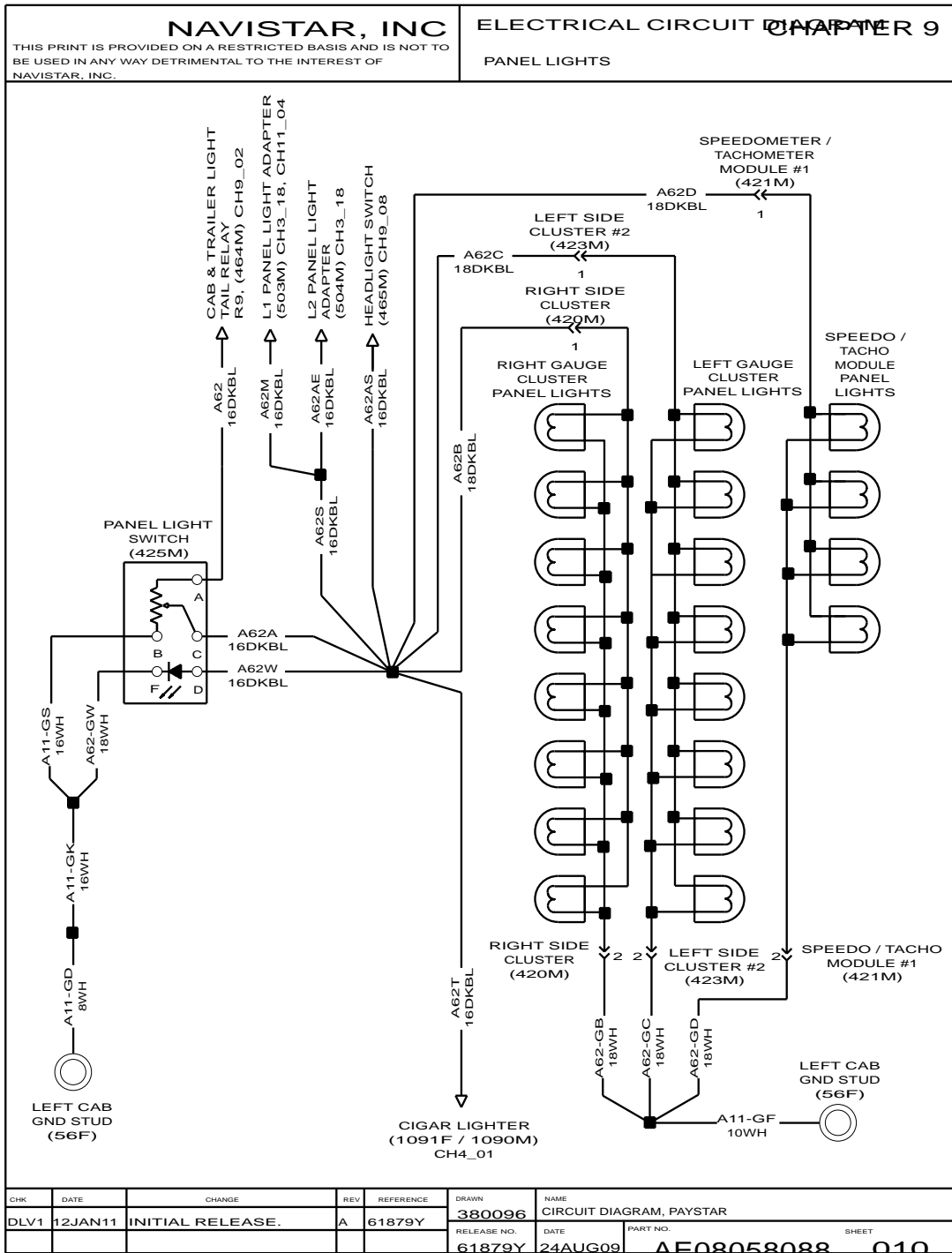


Figure 130 Panel Lights

9.12. PARK / TURN / SIDE MARKER LIGHTS WITH AUXILIARY HEADLIGHTS, P. 11

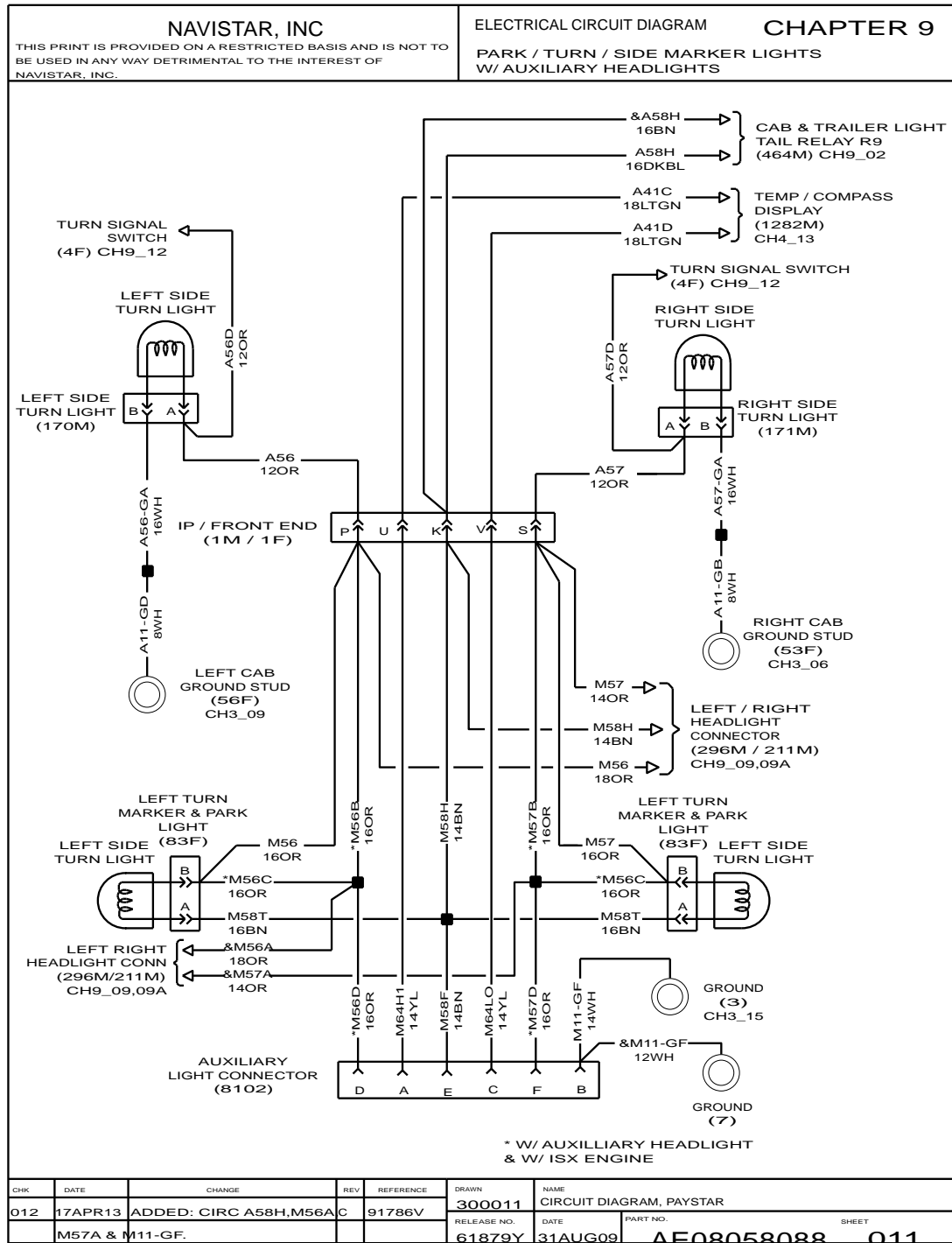


Figure 131 Park / Turn / Side Marker Lights with Auxiliary Headlights

9.13. STOP, TAIL, TURN AND HAZARD SIGNAL LIGHTS WITH FLASHER, P. 12

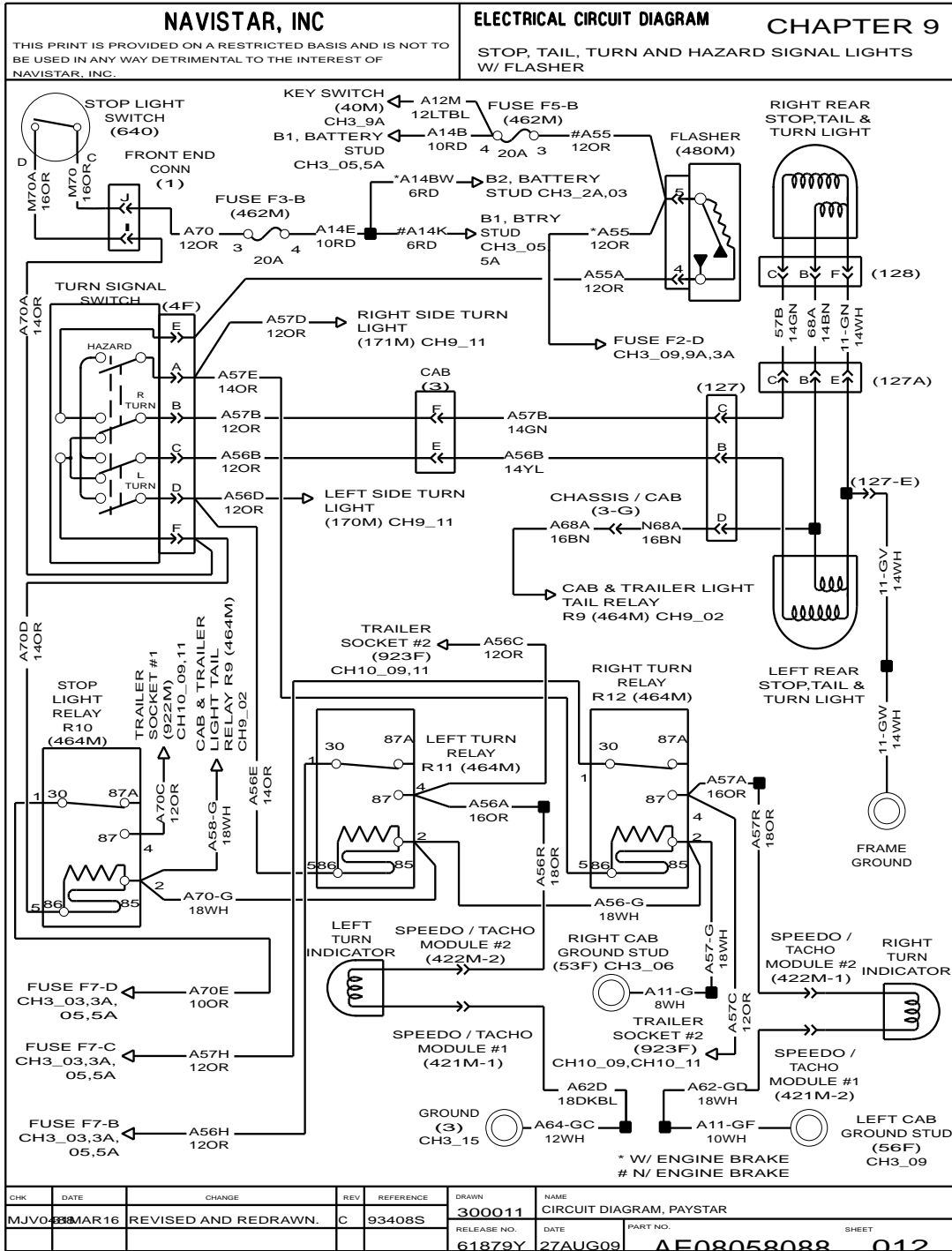


Figure 132 Stop, Tail, Turn and Hazard Signal Lights with Flasher

9.14. BEACON LIGHT, P. 13

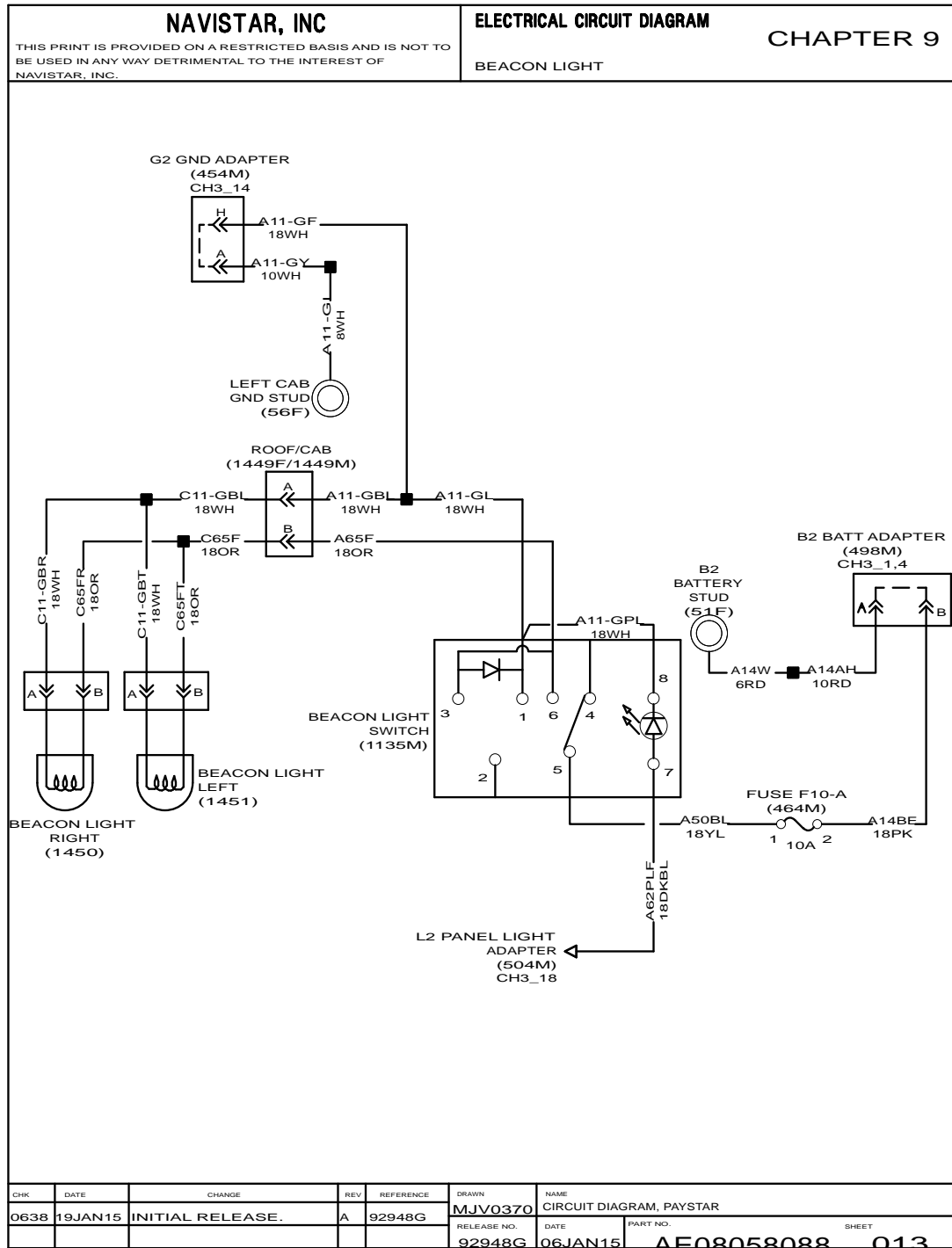


Figure 133 Beacon Light





10.2. BENDIX AIR ABS 4CH WITH ATC, P. 2

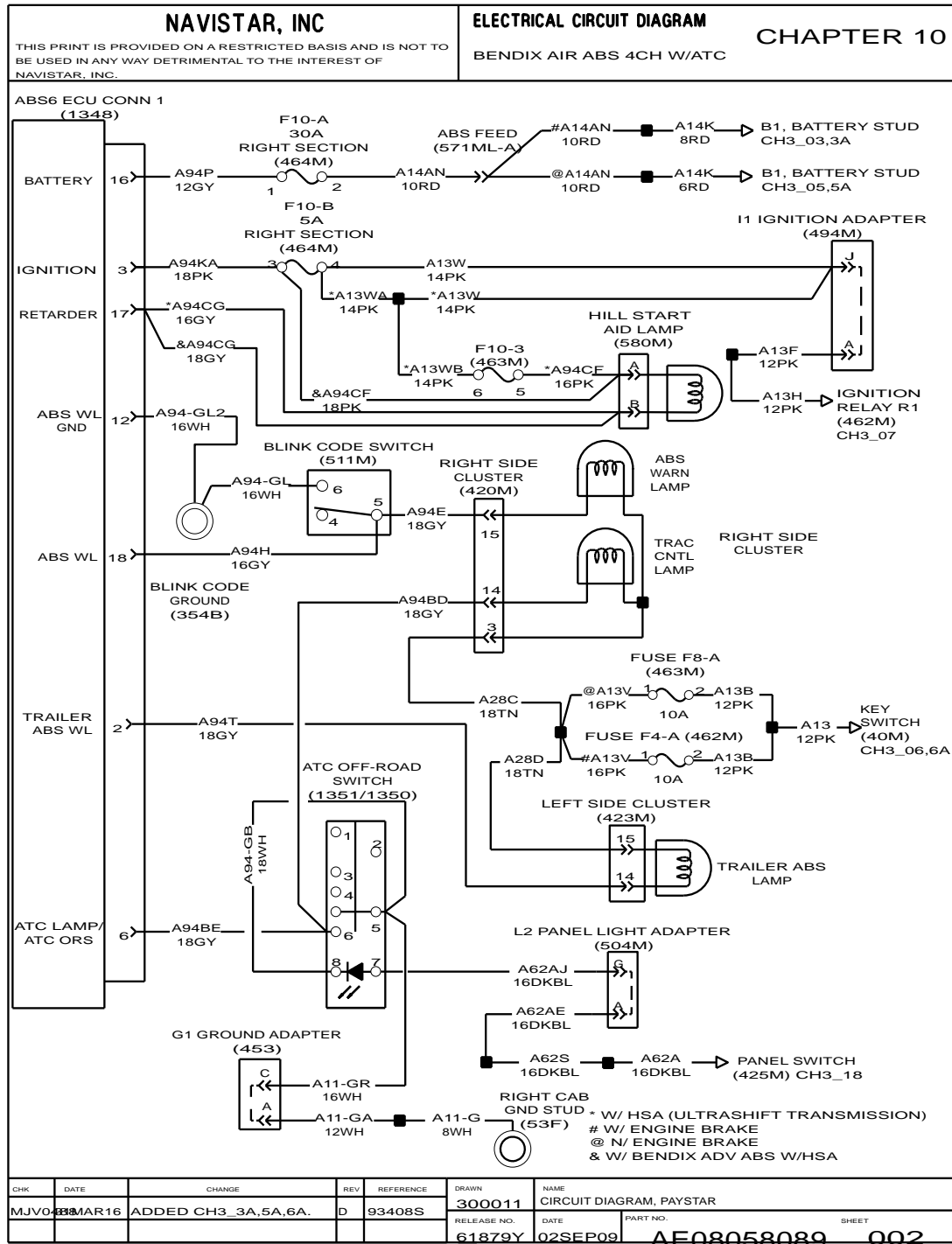


Figure 135 Bendix Air ABS 4CH with ATC

10.3. BENDIX AIR ABS 4CH WITH ATC, P. 3

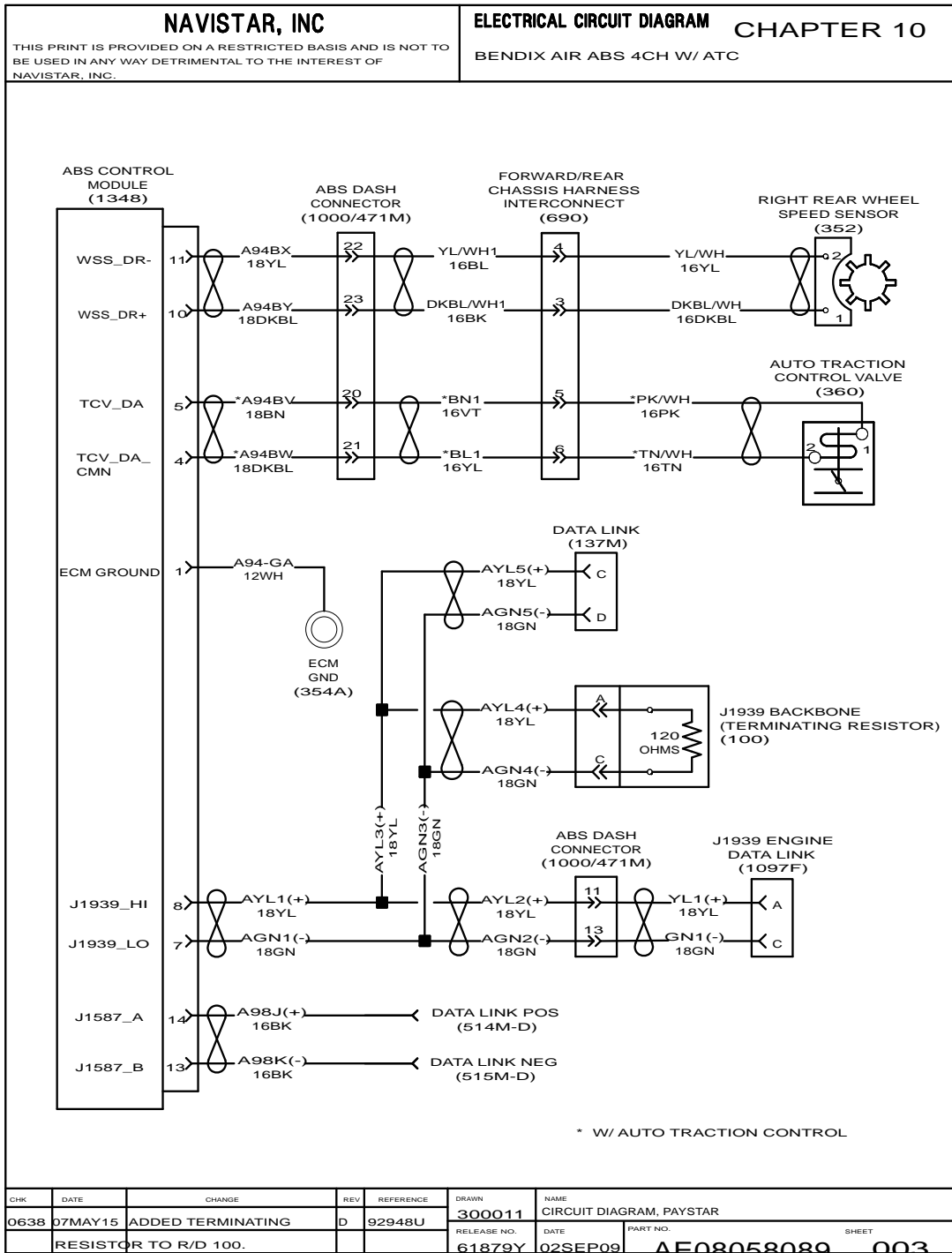


Figure 136 Bendix Air ABS 4CH with ATC

10.4. BENDIX AIR ABS 4CH WITH ATC WITH HSA, P. 4

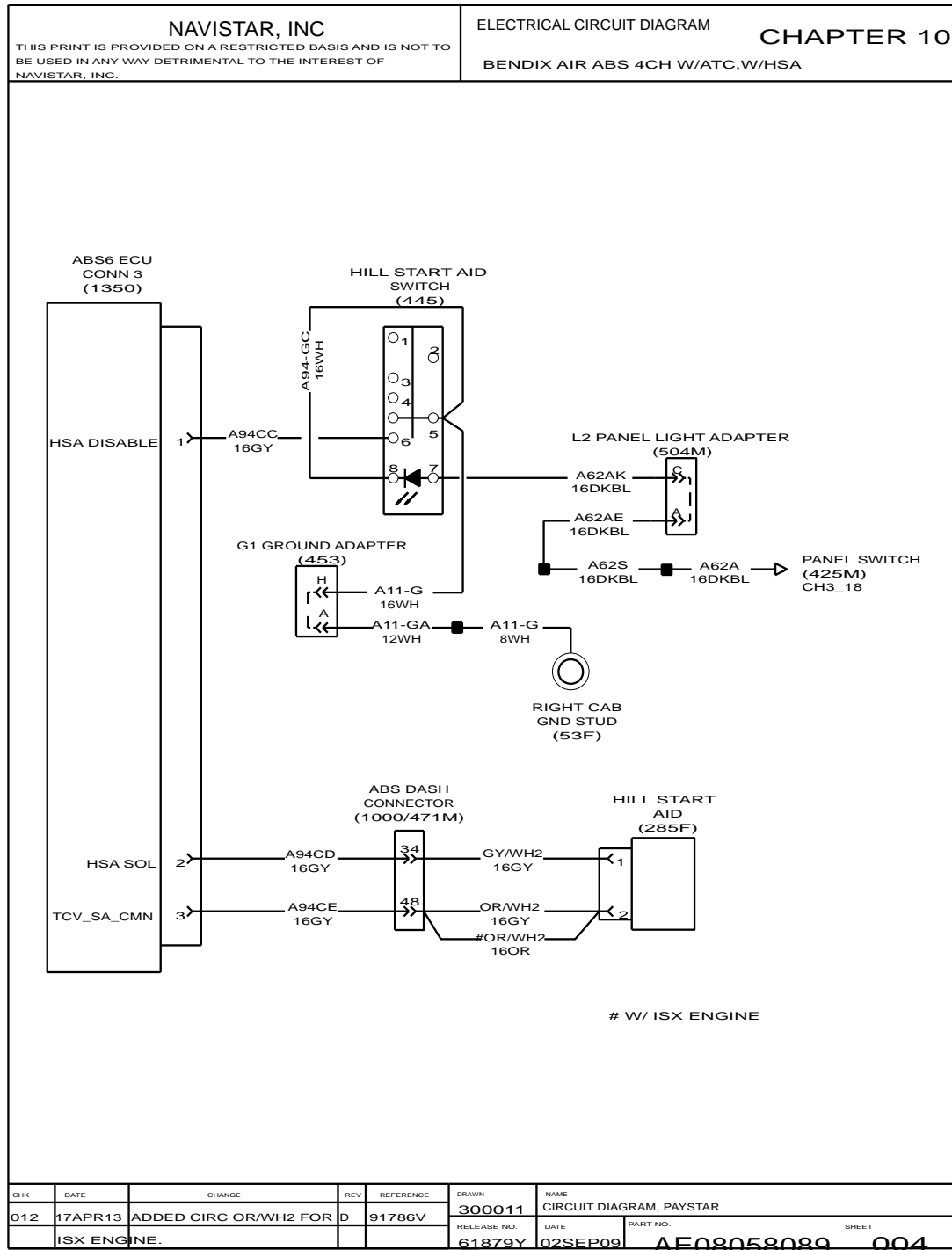


Figure 137 Bendix Air ABS 4CH with ATC with HSA

10.5. BENDIX AIR ABS 4CH WITH ATC, P. 5

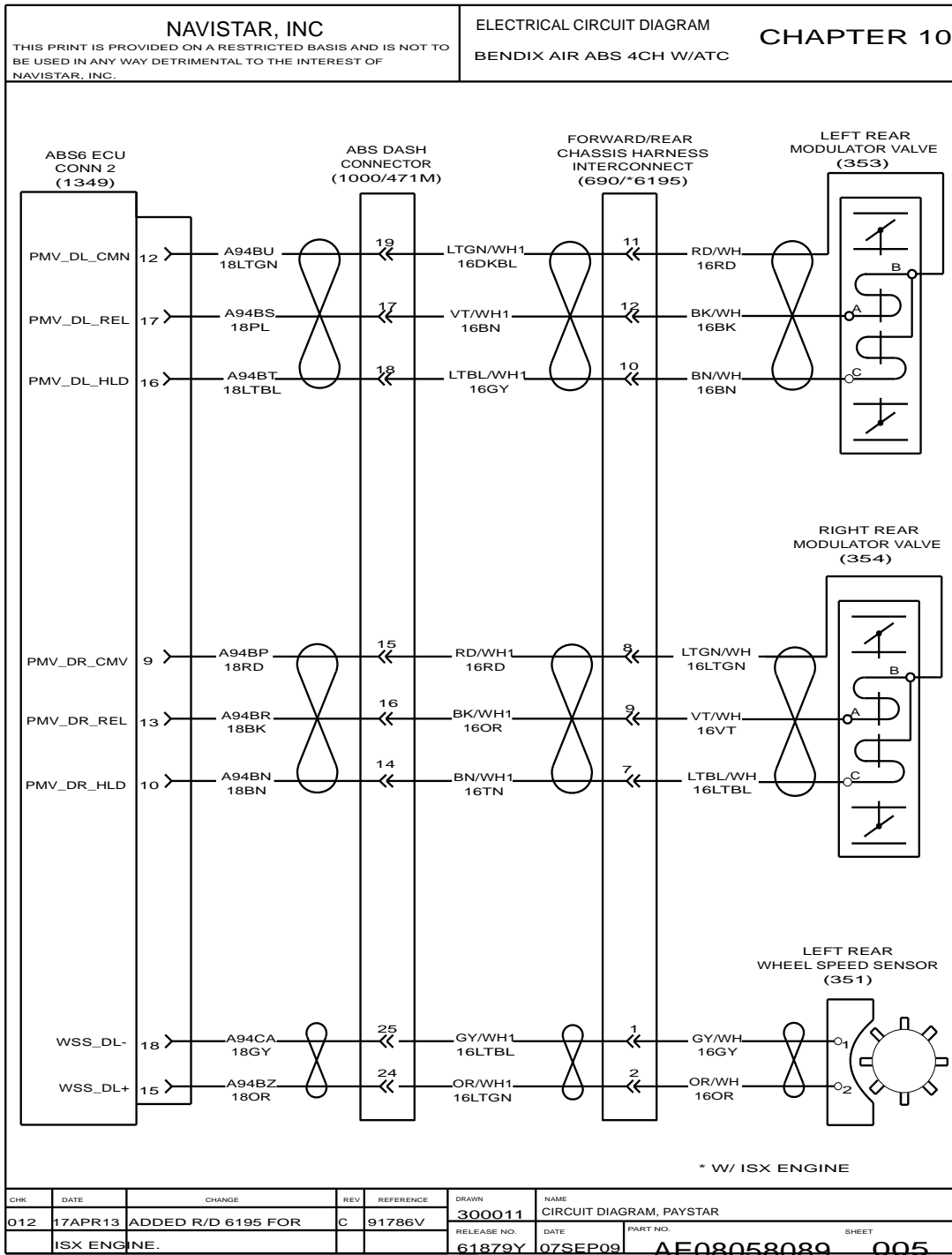


Figure 138 Bendix Air ABS 4CH with ATC

10.6. BENDIX AIR ABS 6CH WITH ATC, P. 6

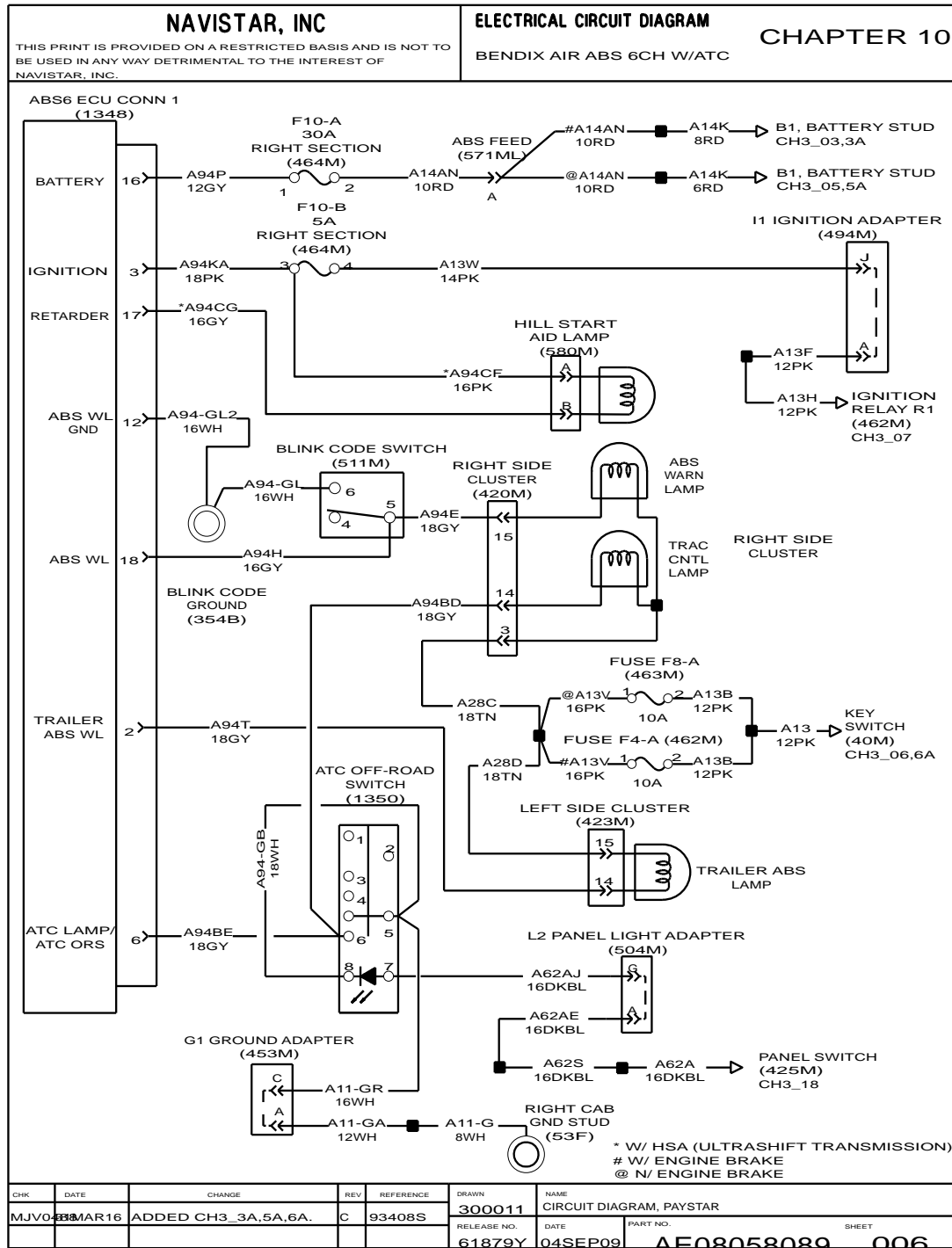


Figure 139 Bendix Air ABS 6CH with ATC

10.7. BENDIX AIR ABS 6CH WITH ATC, P. 7

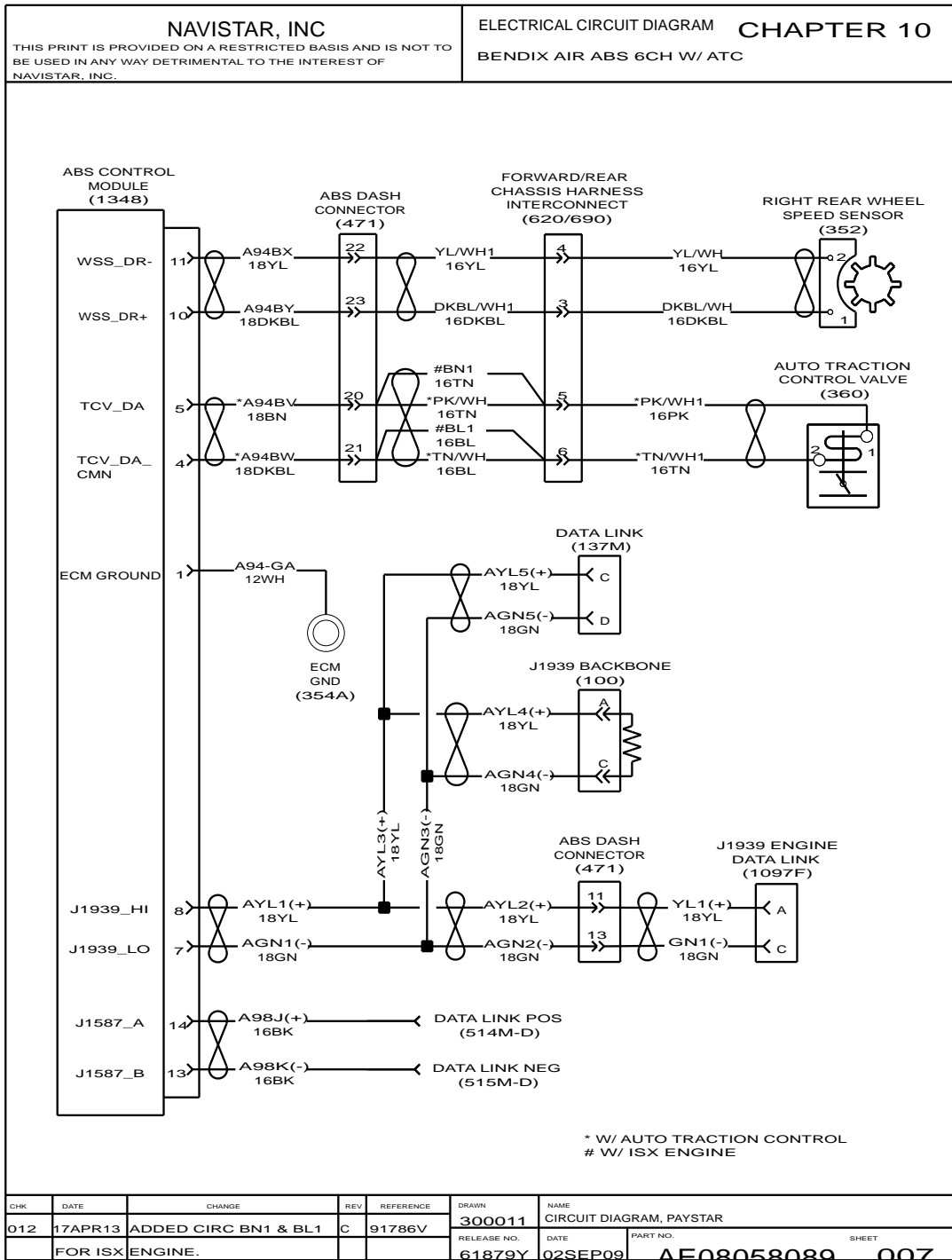


Figure 140 Bendix Air ABS 6CH with ATC

10.8. BENDIX AIR ABS 6CH WITH ATC WITH HSA, P. 8

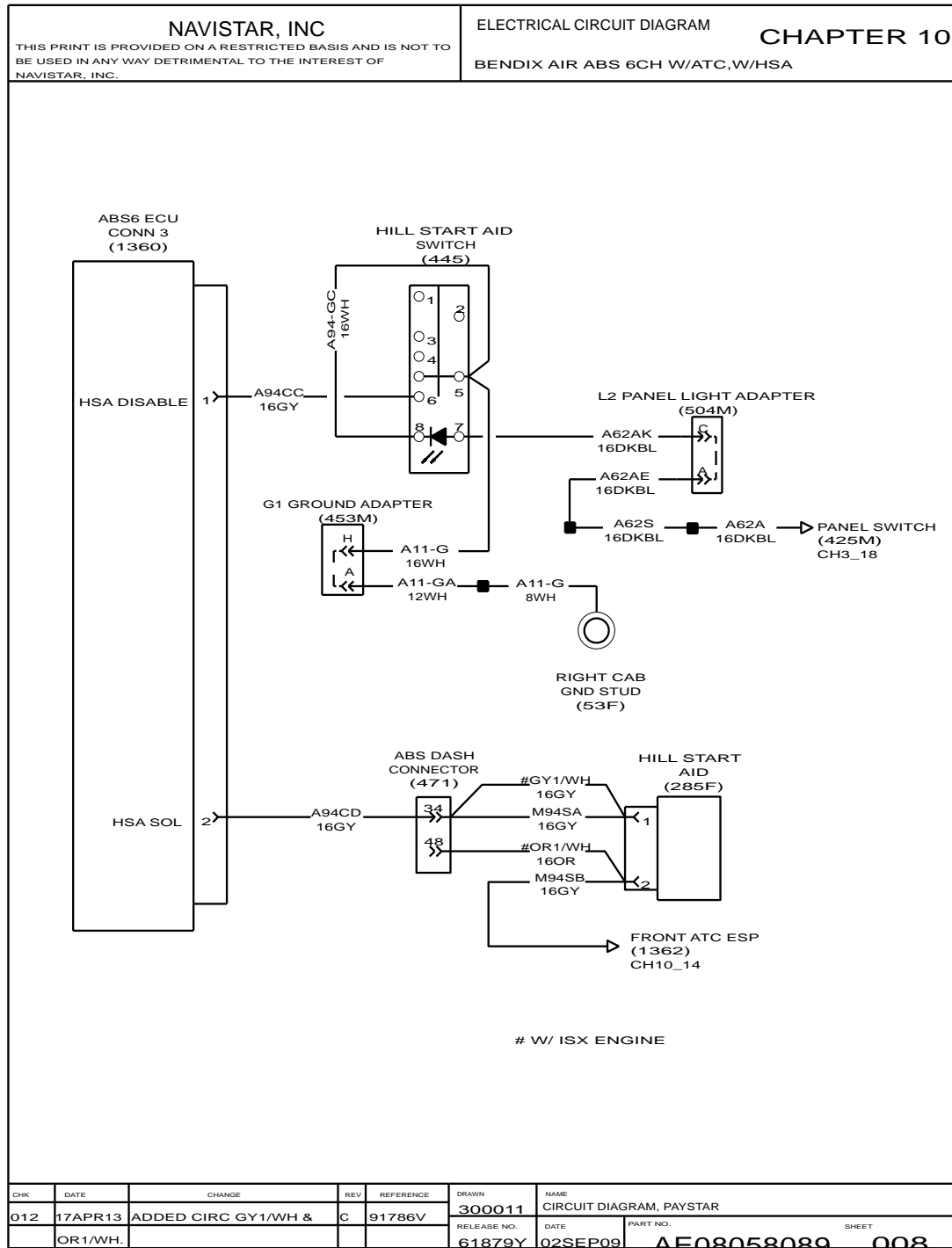


Figure 141 Bendix Air ABS 6CH with ATC with HSA

10.9. BENDIX AIR ABS 6CH WITH ATC, P. 9

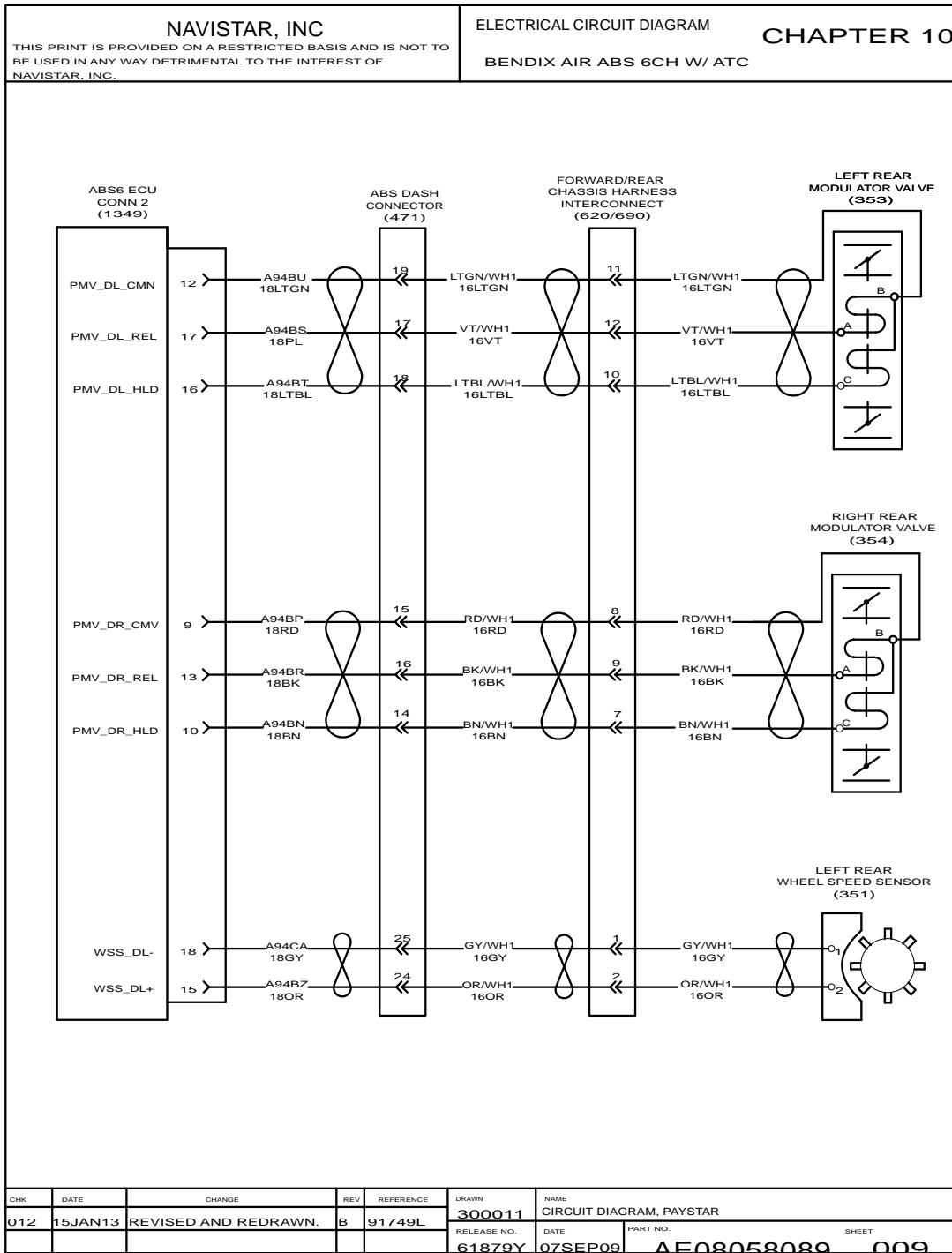


Figure 142 Bendix Air ABS 6CH with ATC



10.10. ABS BENDIX AIR 6S / 6M (6X4), P. 10

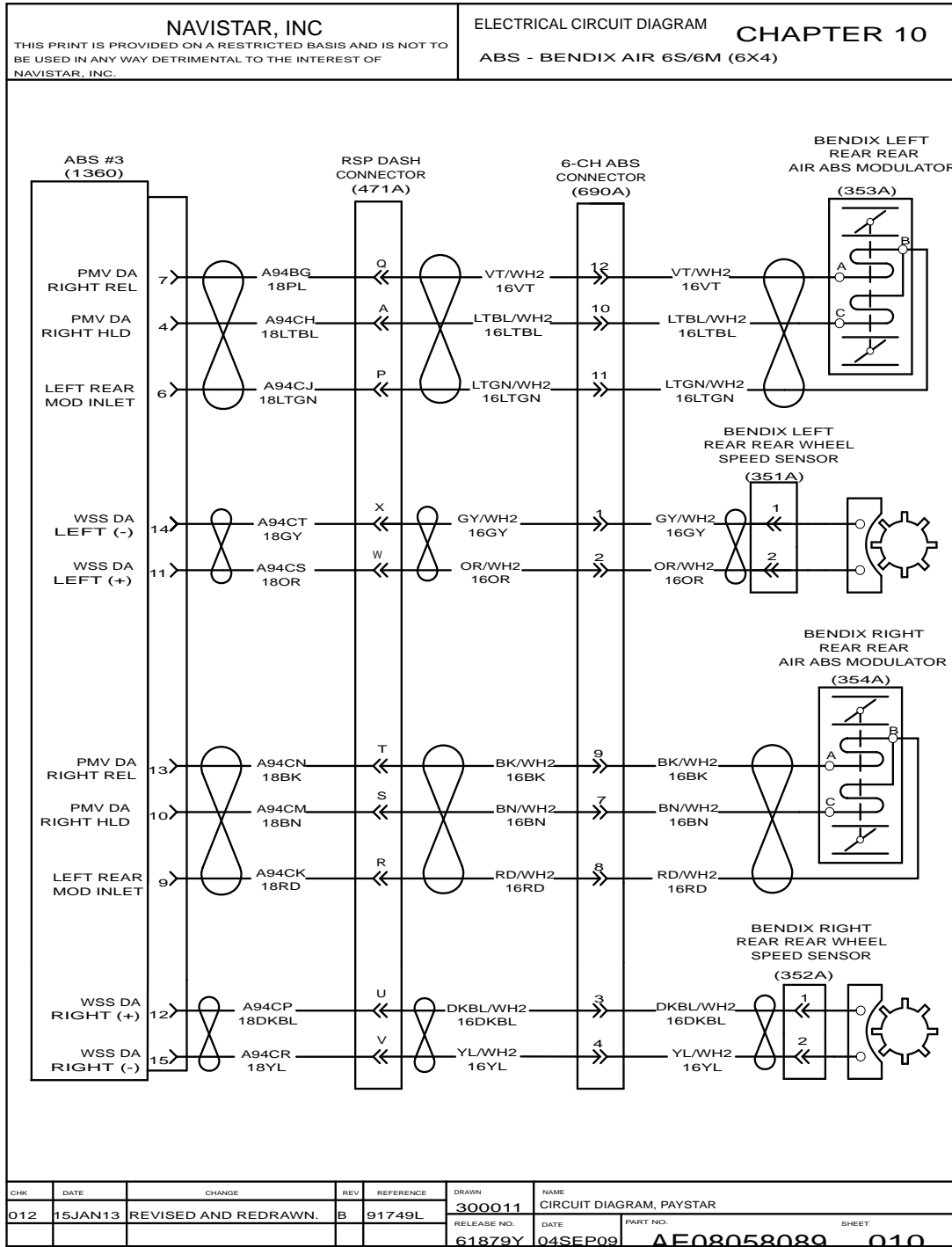


Figure 143 ABS Bendix Air 6S / 6M (6X4)

10.11. BENDIX AIR ABS WITH ATC, P. 11

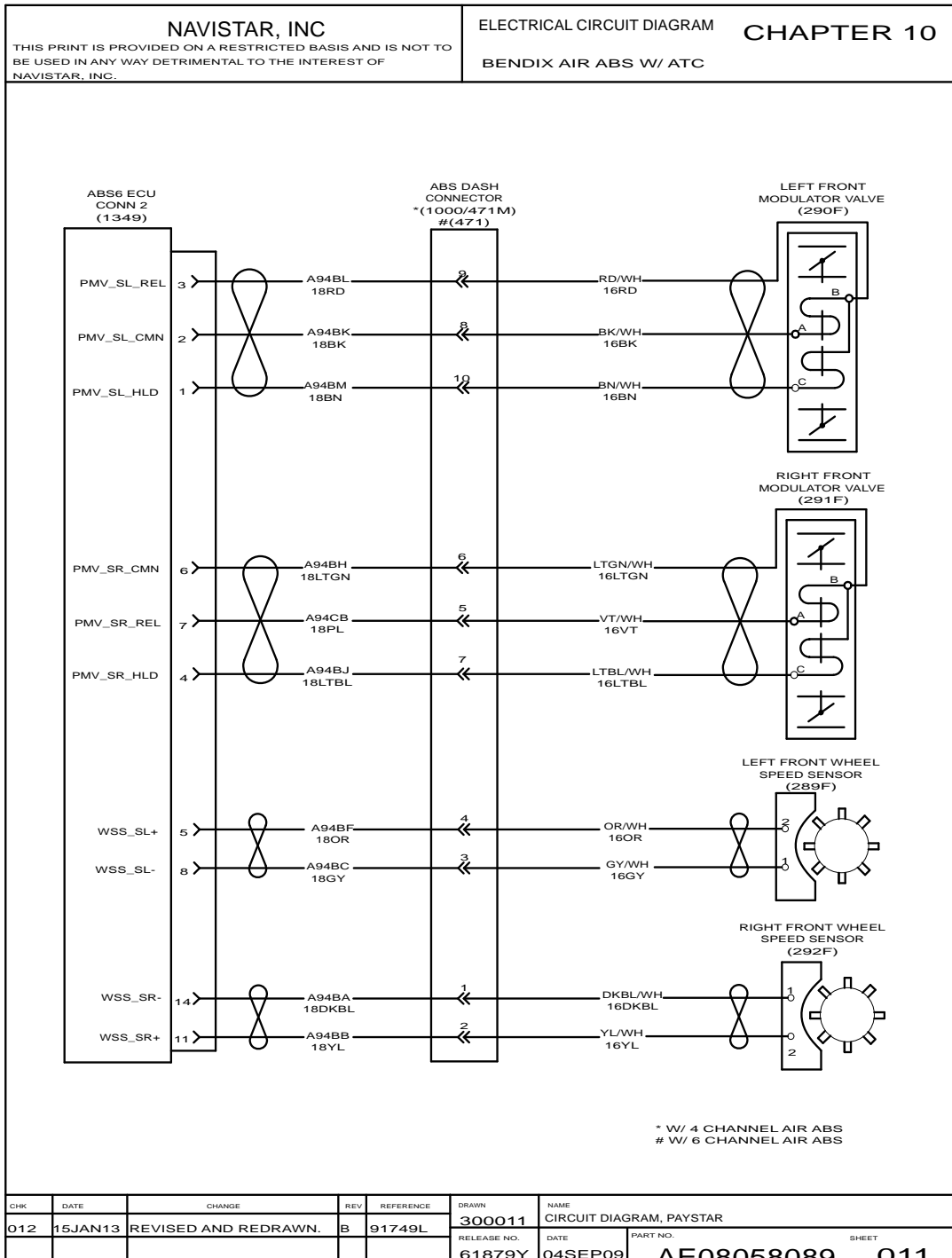


Figure 144 Bendix Air ABS with ATC

10.12. BENDIX ADVANCE AIR ABS, P. 12

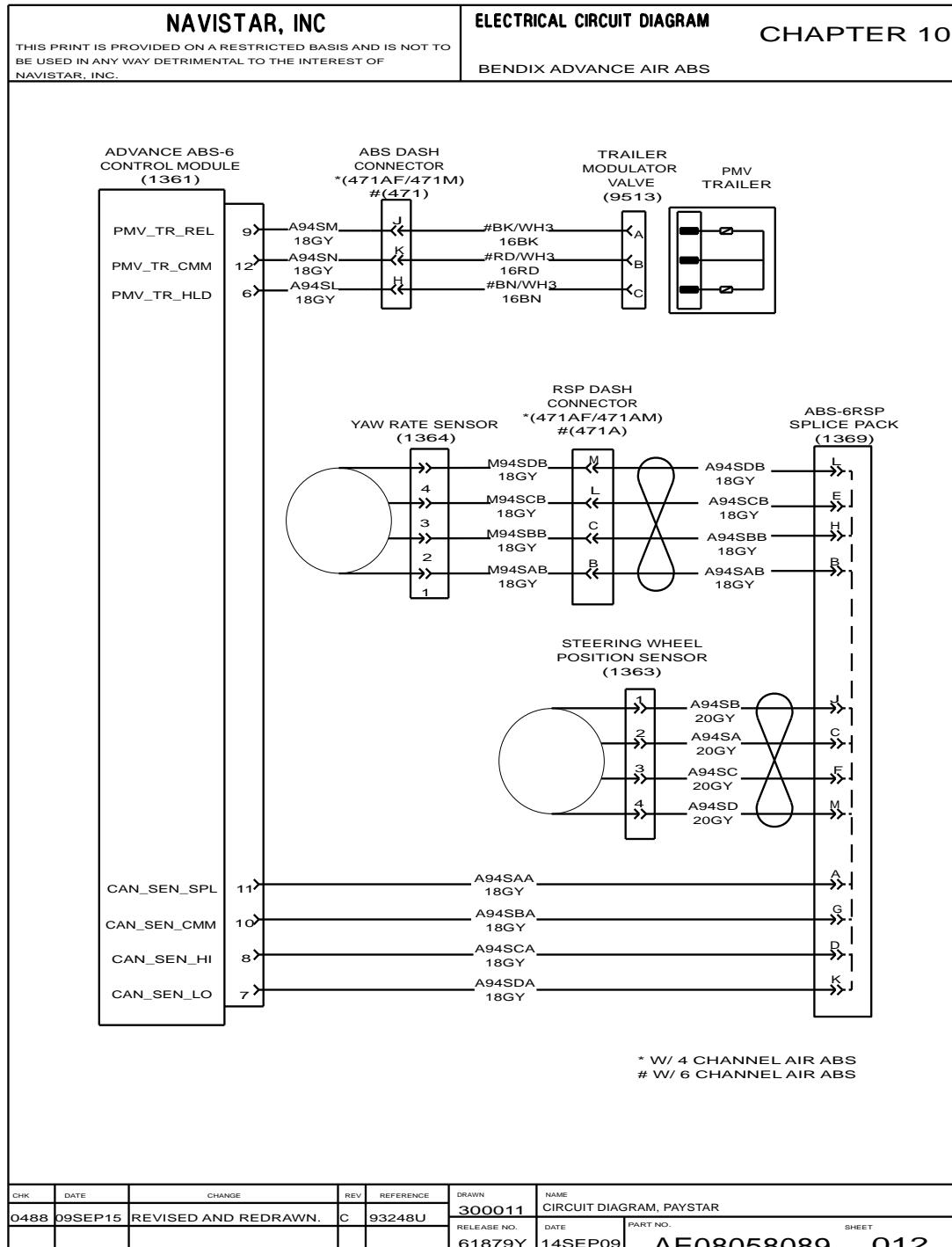


Figure 145 Bendix Advance Air ABS

10.13. BENDIX ADVANCE AIR ABS (CONT.), P. 13

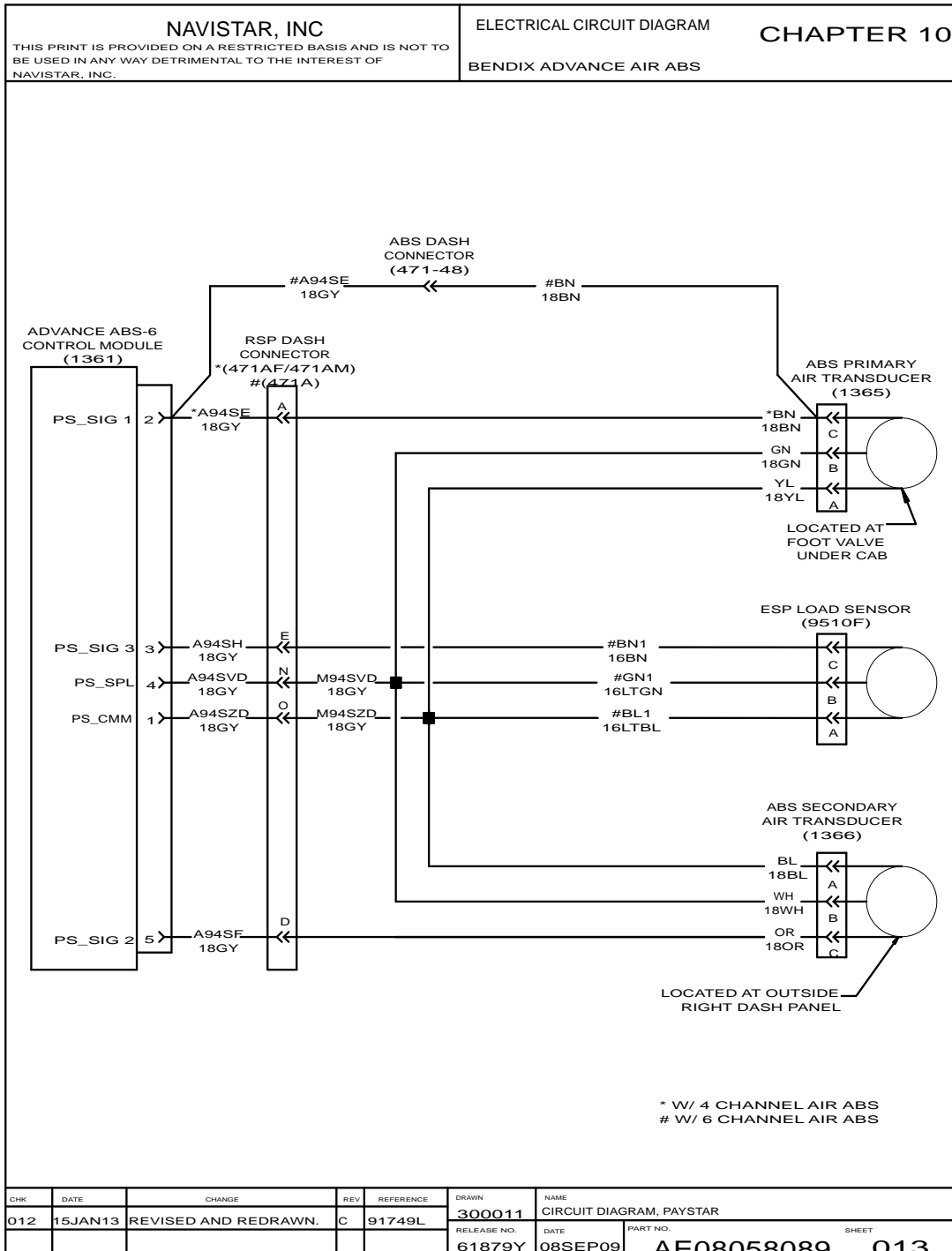


Figure 146 Bendix Advance Air ABS (Cont.)

10.14. BENDIX ADVANCE AIR ABS (CONT.), P. 14

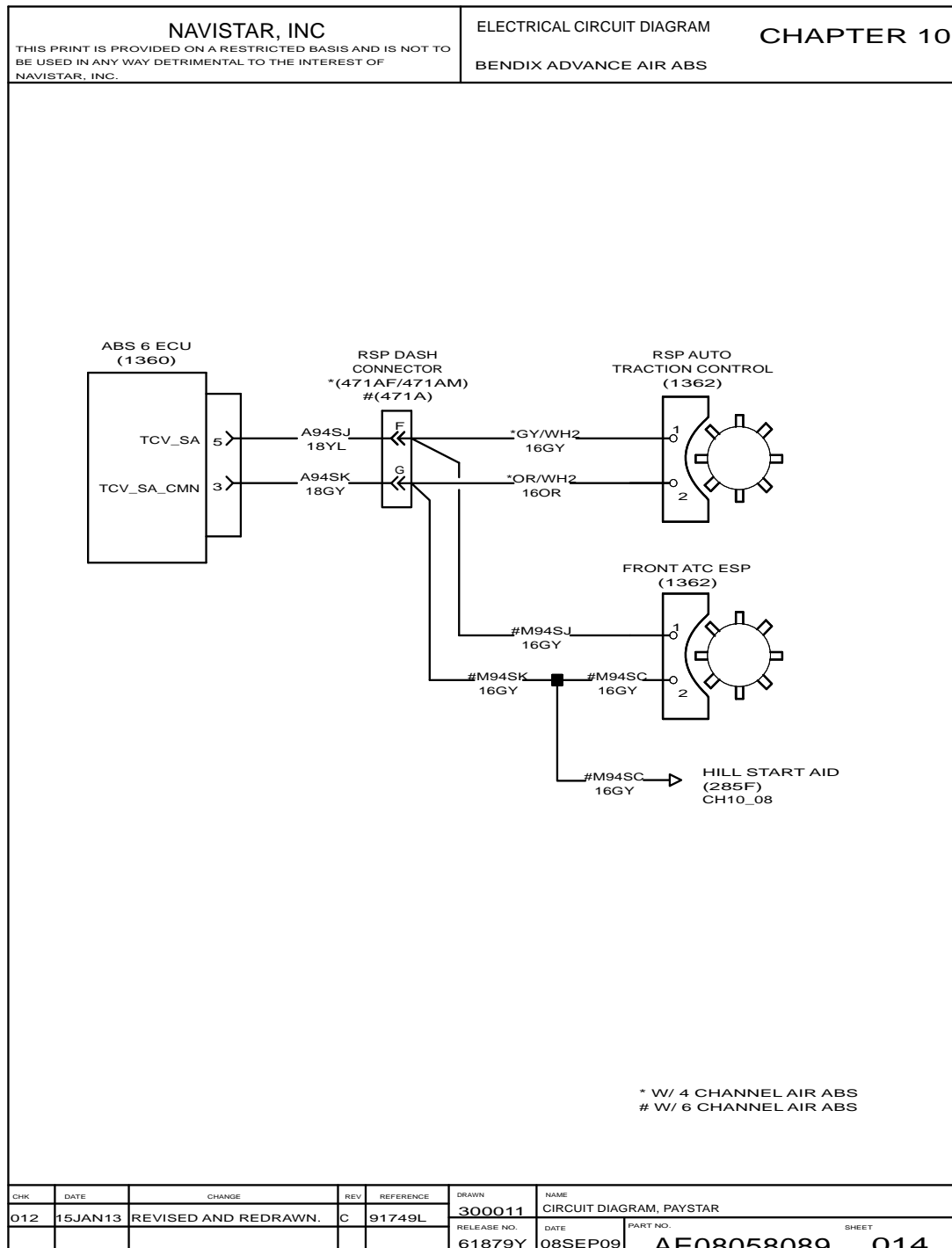


Figure 147 Bendix Advance Air ABS (Cont.)

10.15. BENDIX ADVANCE AIR ABS FOR 6CH, P. 15

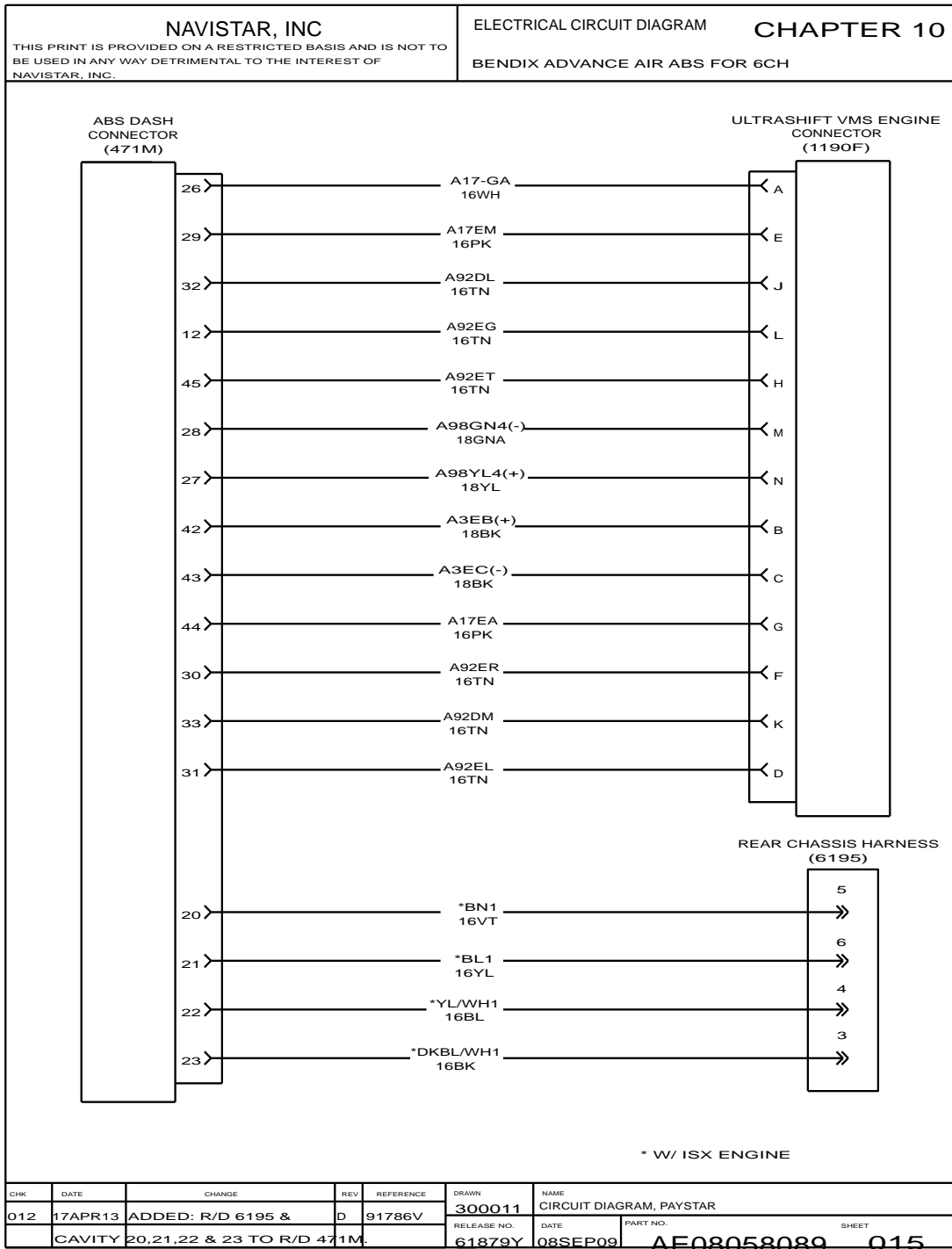


Figure 148 Bendix Advance Air ABS for 6CH

10.16. TRAILER CONNECTION WITH FOUR WHEEL TRAILER FRAME MOUNTED, P. 16

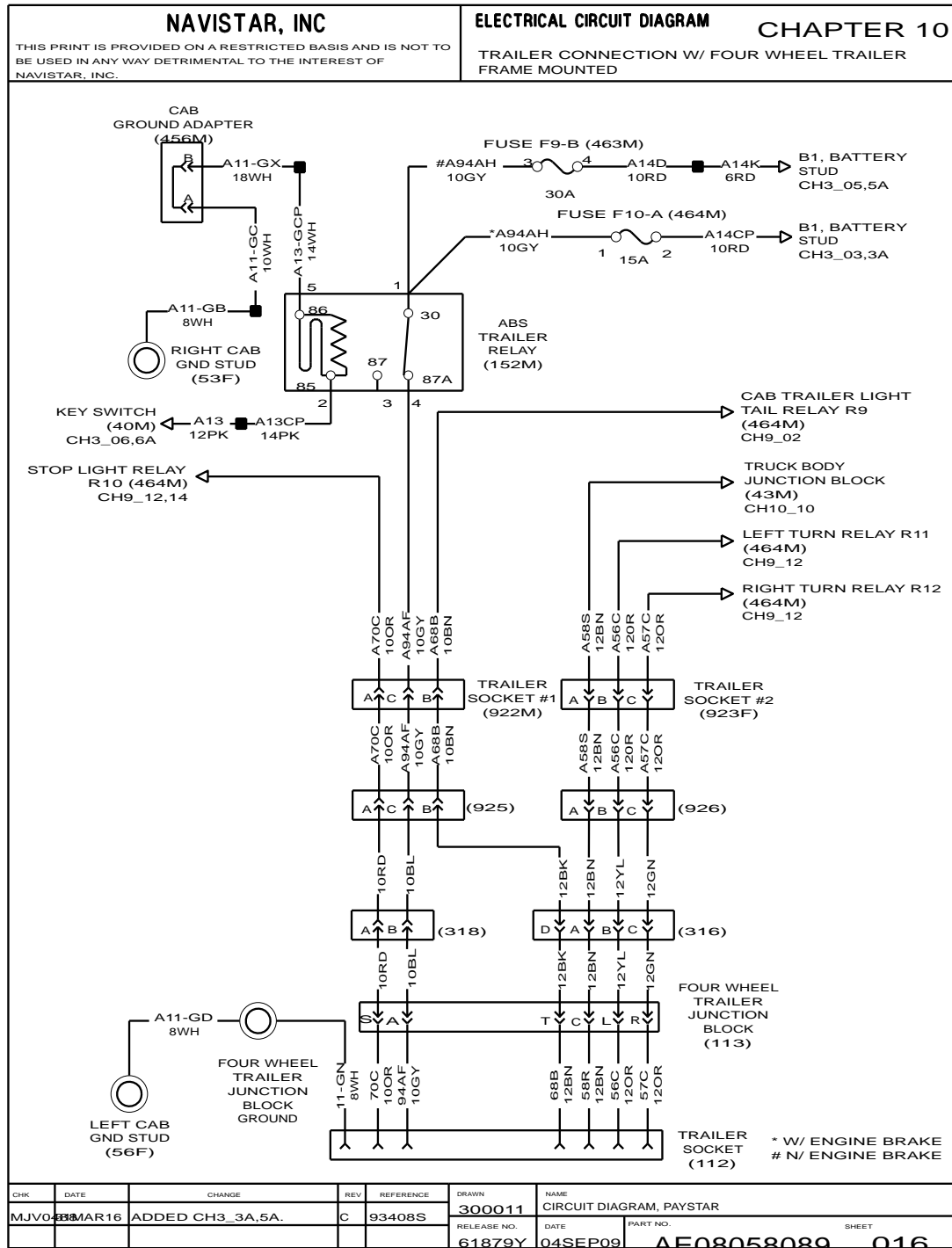


Figure 149 Trailer Connection with Four Wheel Trailer Frame Mounted

10.17. TRUCK BODY CONNECTION, P. 17

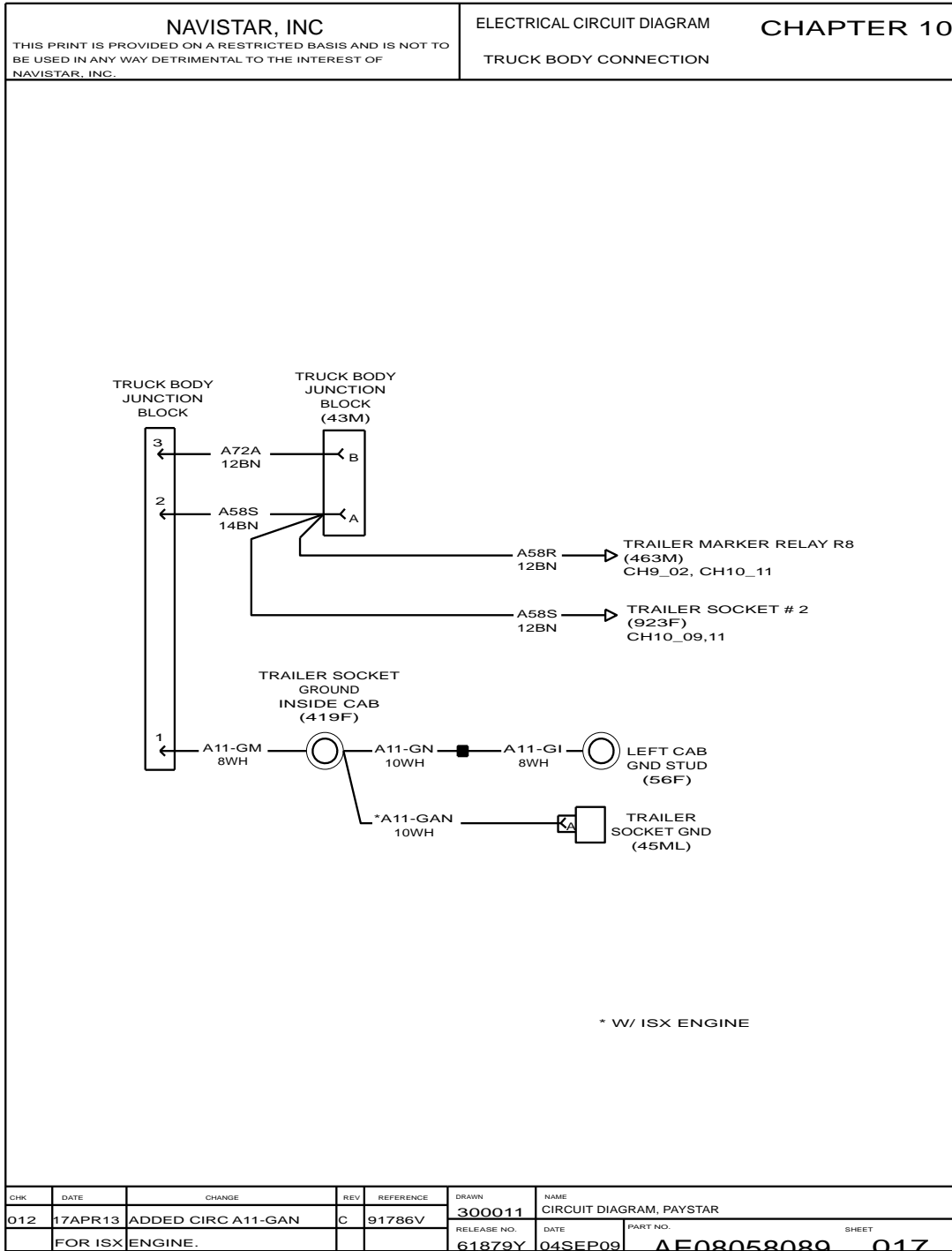


Figure 150 Truck Body Connection



10.18. TRAILER CONNECTION WITHOUT SLEEPER BACK OF CAB MOUNTED WITH TRACTOR ABS, P. 18

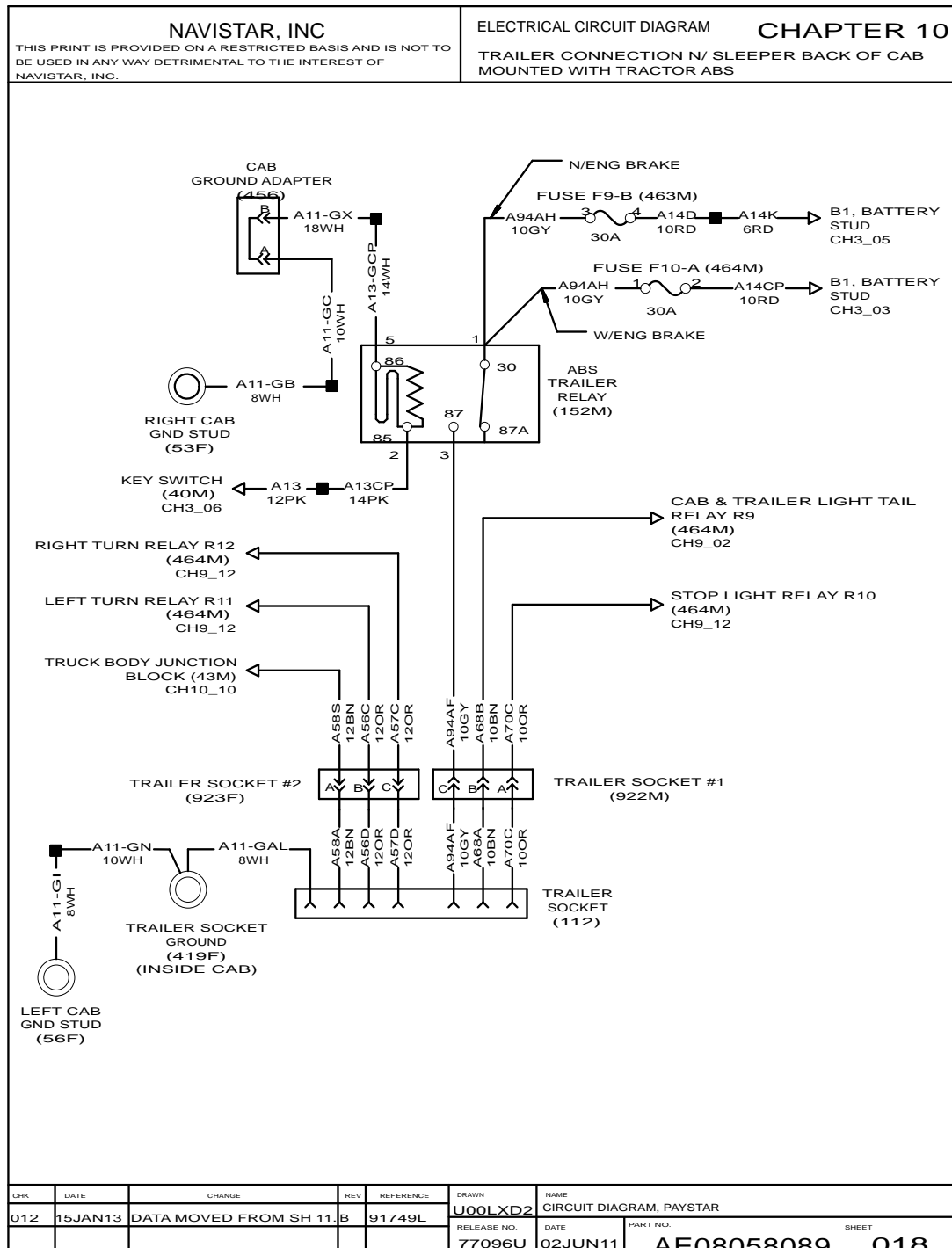


Figure 151 Trailer Connection without Sleeper Back of Cab Mounted with Tractor ABS

10.19. INTENTIONALLY LEFT BLANK, P. 19

NAVISTAR, INC <small>THIS PRINT IS PROVIDED ON A RESTRICTED BASIS AND IS NOT TO BE USED IN ANY WAY DETRIMENTAL TO THE INTEREST OF NAVISTAR, INC.</small>				ELECTRICAL CIRCUIT DIAGRAM <b>CHAPTER 10</b>				
<p style="font-size: 24px; margin: 0;">GEOMETRY REMOVED</p>								
CHK	DATE	CHANGE	REV	REFERENCE	DRAWN	NAME		
012	18JAN13	GEOMETRY REMOVED.	B	91922L	U00LXD2	CIRCUIT DIAGRAM, PAYSTAR		
					RELEASE NO.	DATE	PART NO.	SHEET
					77096U	02JUN11	AE08058089	019

Figure 152 Intentionally Left Blank

10.20. INTENTIONALLY LEFT BLANK, P. 20

<b>NAVISTAR, INC</b> <small>THIS PRINT IS PROVIDED ON A RESTRICTED BASIS AND IS NOT TO BE USED IN ANY WAY DETRIMENTAL TO THE INTEREST OF NAVISTAR, INC.</small>				ELECTRICAL CIRCUIT DIAGRAM <b>CHAPTER 10</b>			
<p style="font-size: 24px; margin: 0;">GEOMETRY REMOVED</p>							
CHK	DATE	CHANGE	REV	REFERENCE	DRAWN	NAME	
012	18JAN13	GEOMETRY REMOVED.	B	91922L	U00LXD2	CIRCUIT DIAGRAM, PAYSTAR	
					RELEASE NO.	DATE	
					77096U	31MAY11	
						PART NO.	
						AE08058089	
						SHEET	
						020	

Figure 153 Intentionally Left Blank

10.21. INTENTIONALLY LEFT BLANK, P. 21

<b>NAVISTAR, INC</b> <small>THIS PRINT IS PROVIDED ON A RESTRICTED BASIS AND IS NOT TO BE USED IN ANY WAY DETRIMENTAL TO THE INTEREST OF NAVISTAR, INC.</small>				ELECTRICAL CIRCUIT DIAGRAM <b>CHAPTER 10</b>			
<p style="font-size: 24px; margin: 0;">GEOMETRY REMOVED</p>							
CHK	DATE	CHANGE	REV	REFERENCE	DRAWN	NAME	
012	18JAN13	GEOMETRY REMOVED.	B	91922L	U00LXD2	CIRCUIT DIAGRAM, PAYSTAR	
					RELEASE NO.	DATE	
					77096U	01JUN11	
						PART NO.	
						AE08058089	
						SHEET	
						021	

Figure 154 Intentionally Left Blank

10.22. INTENTIONALLY LEFT BLANK, P. 22

<b>NAVISTAR, INC</b> <small>THIS PRINT IS PROVIDED ON A RESTRICTED BASIS AND IS NOT TO BE USED IN ANY WAY DETRIMENTAL TO THE INTEREST OF NAVISTAR, INC.</small>				ELECTRICAL CIRCUIT DIAGRAM <b>CHAPTER 10</b>			
<p style="font-size: 24px; margin: 0;">GEOMETRY REMOVED</p>							
<small>CHK</small>	<small>DATE</small>	<small>CHANGE</small>	<small>REV</small>	<small>REFERENCE</small>	<small>DRAWN</small>	<small>NAME</small>	
		GEOMETRY REMOVED.				CIRCUIT DIAGRAM, PAYSTAR	
					<small>RELEASE NO.</small>	<small>DATE</small>	
						<small>PART NO.</small> <b>AE08058089</b> <small>SHEET</small> <b>022</b>	

Figure 155 Intentionally Left Blank

10.23. APADS MODULE FOR ISX 2013 ENGINES, P. 23

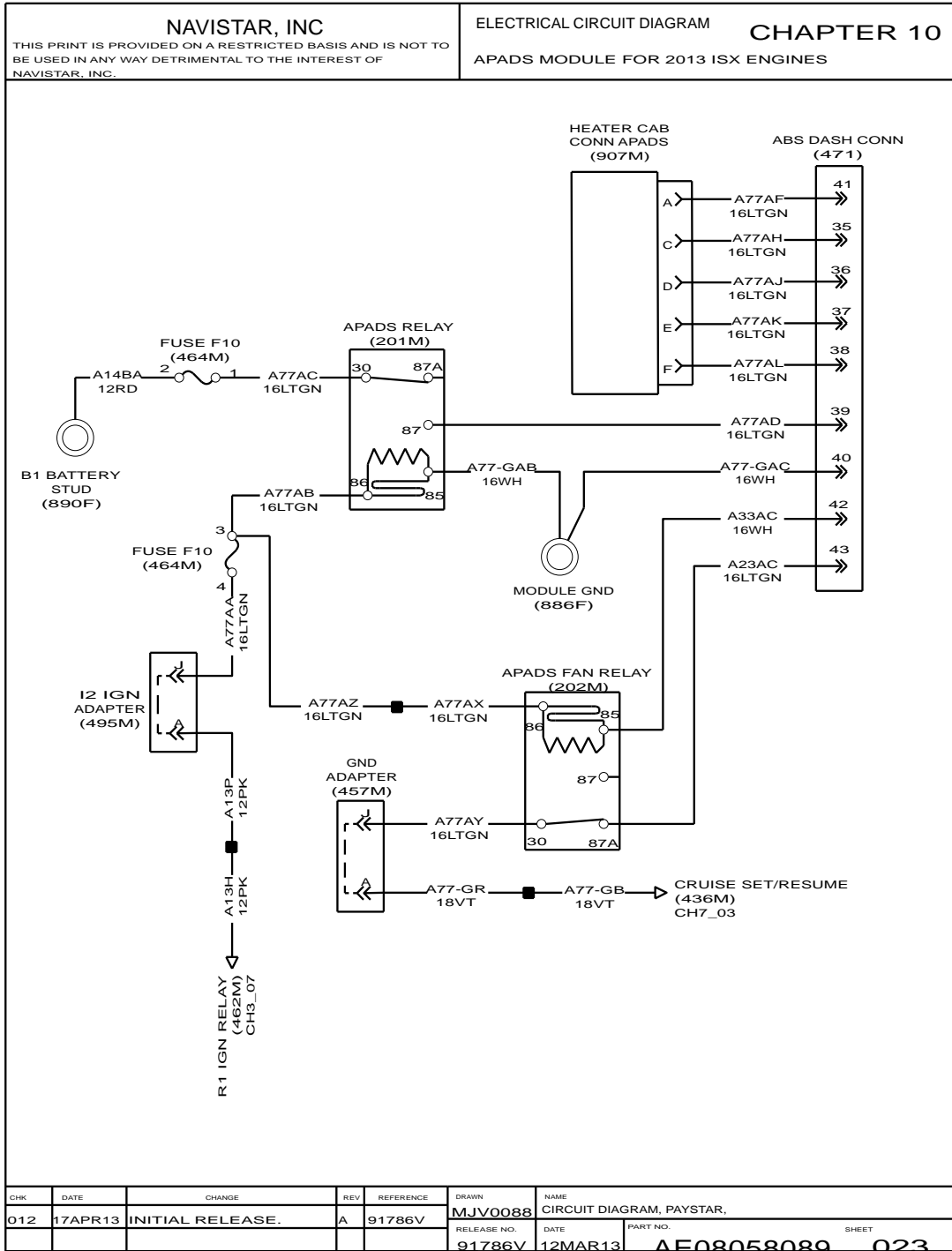


Figure 156 APADS Module for ISX 2013 Engines

10.24. BODY BUILDER CONNECTIONS WITH IBB ENG (SCR EFFECTS), P. 24

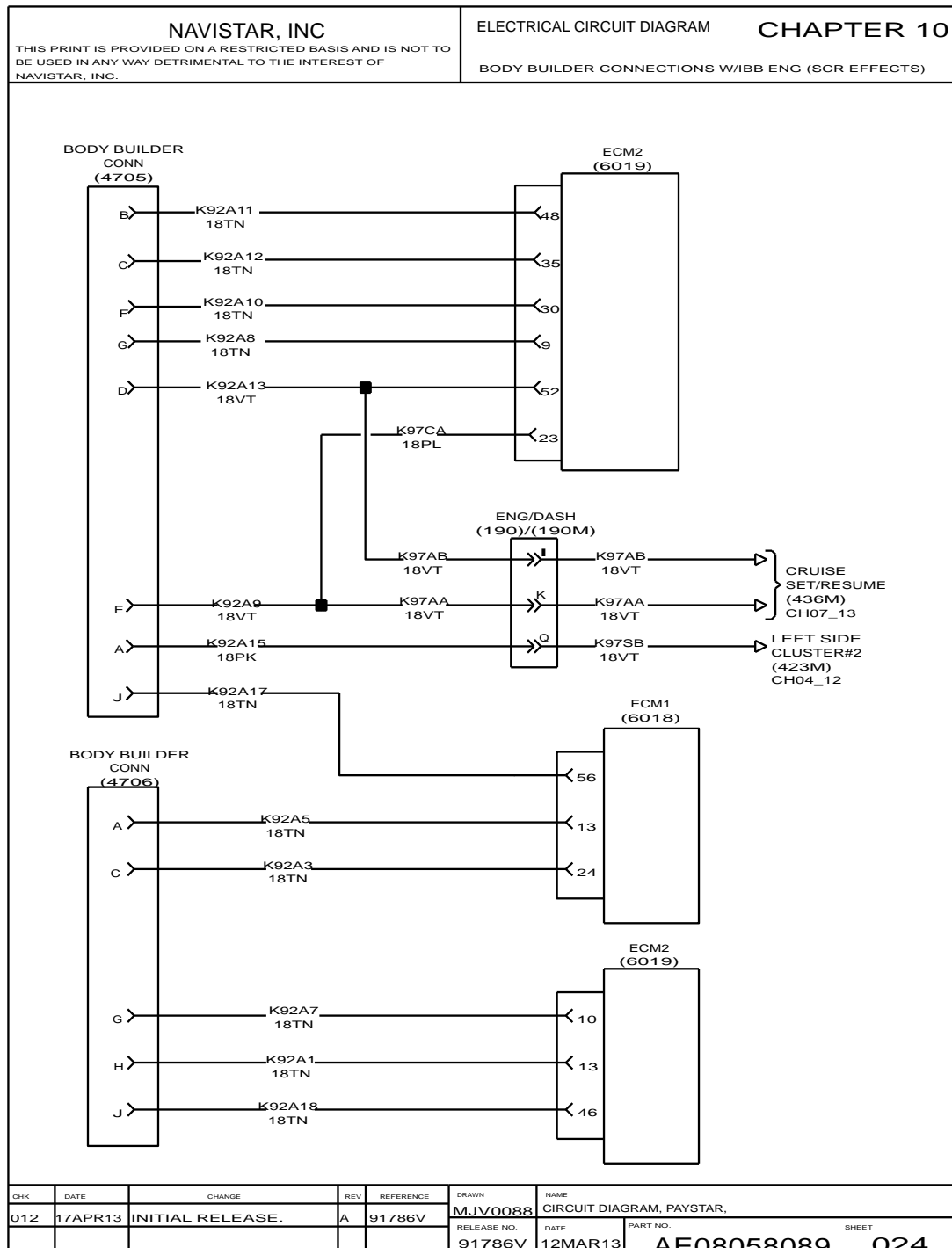


Figure 157 Body Builder Connections with IBB ENG (SCR Effects)

10.25. BODY BUILDER CONNECTIONS WITH 15L ENG (ISX 2013), P. 25

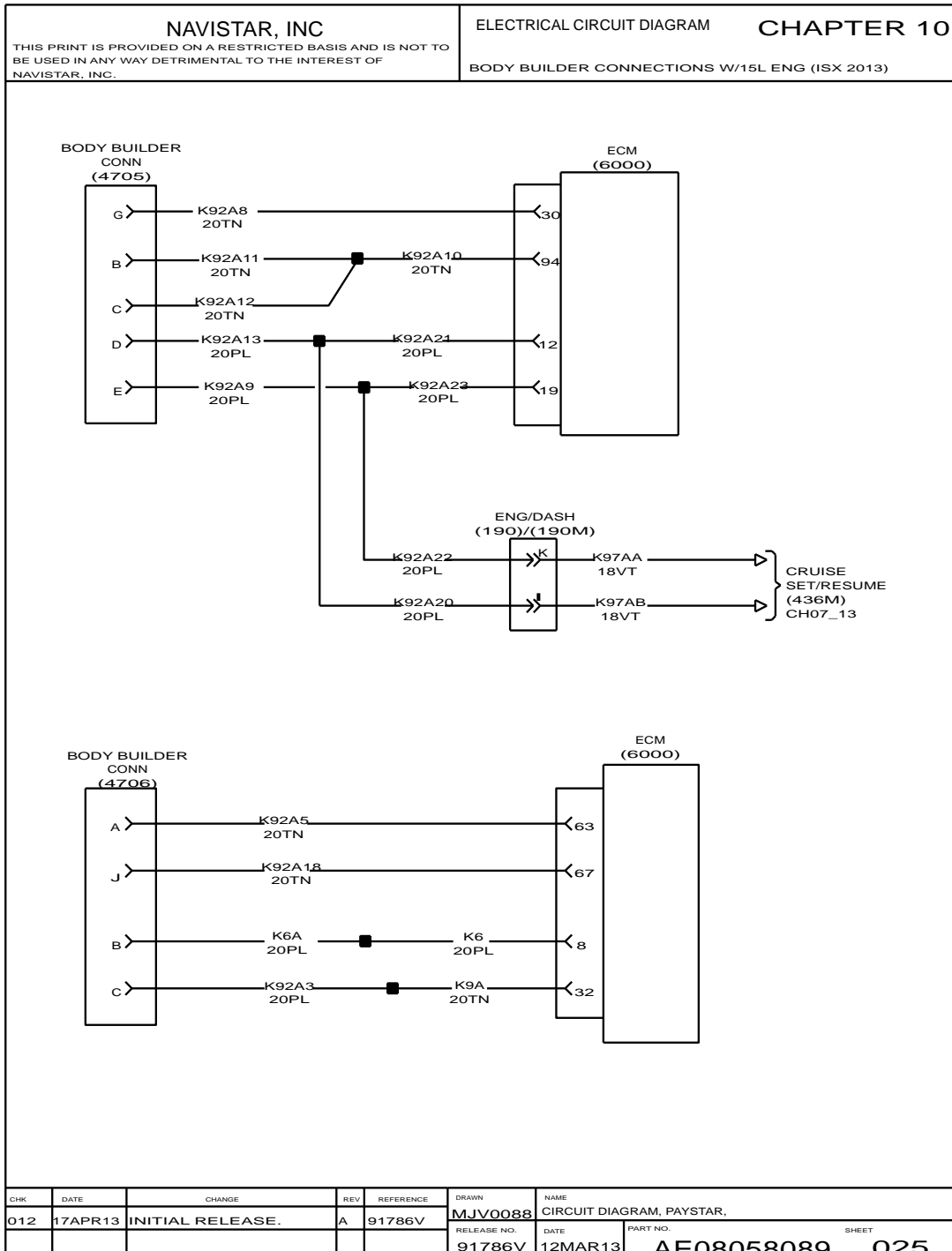


Figure 158 Body Builder Connections with 15L ENG (ISX 2013)



10.26. TRI AXLE DIFFERENTIAL LOCK, P. 26

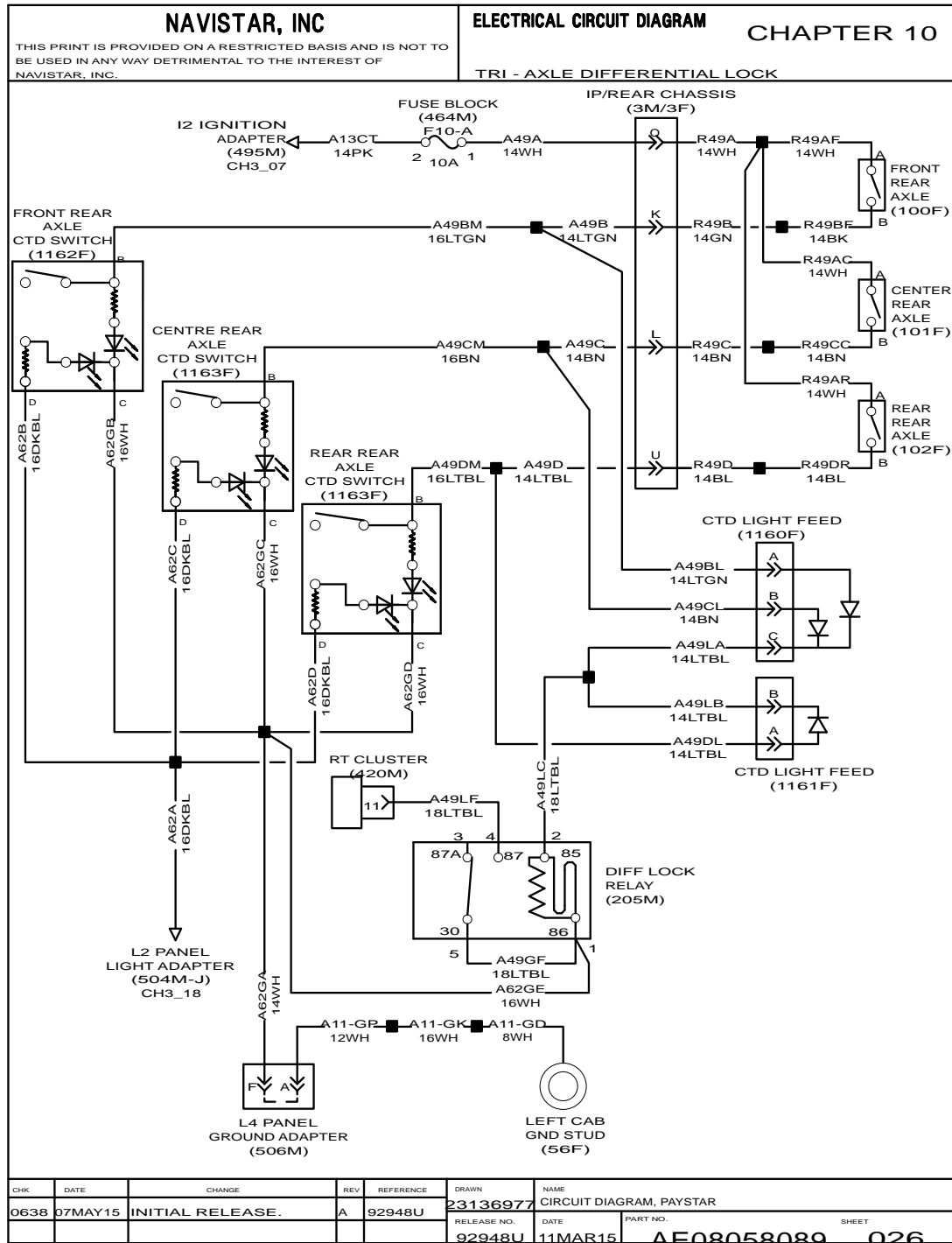


Figure 159 Tri Axle Differential Lock

# TRANSMISSION CONTROL MODULE (CHAPTER 11)

## 11.1. ALLISON TRANSMISSION, P. 1

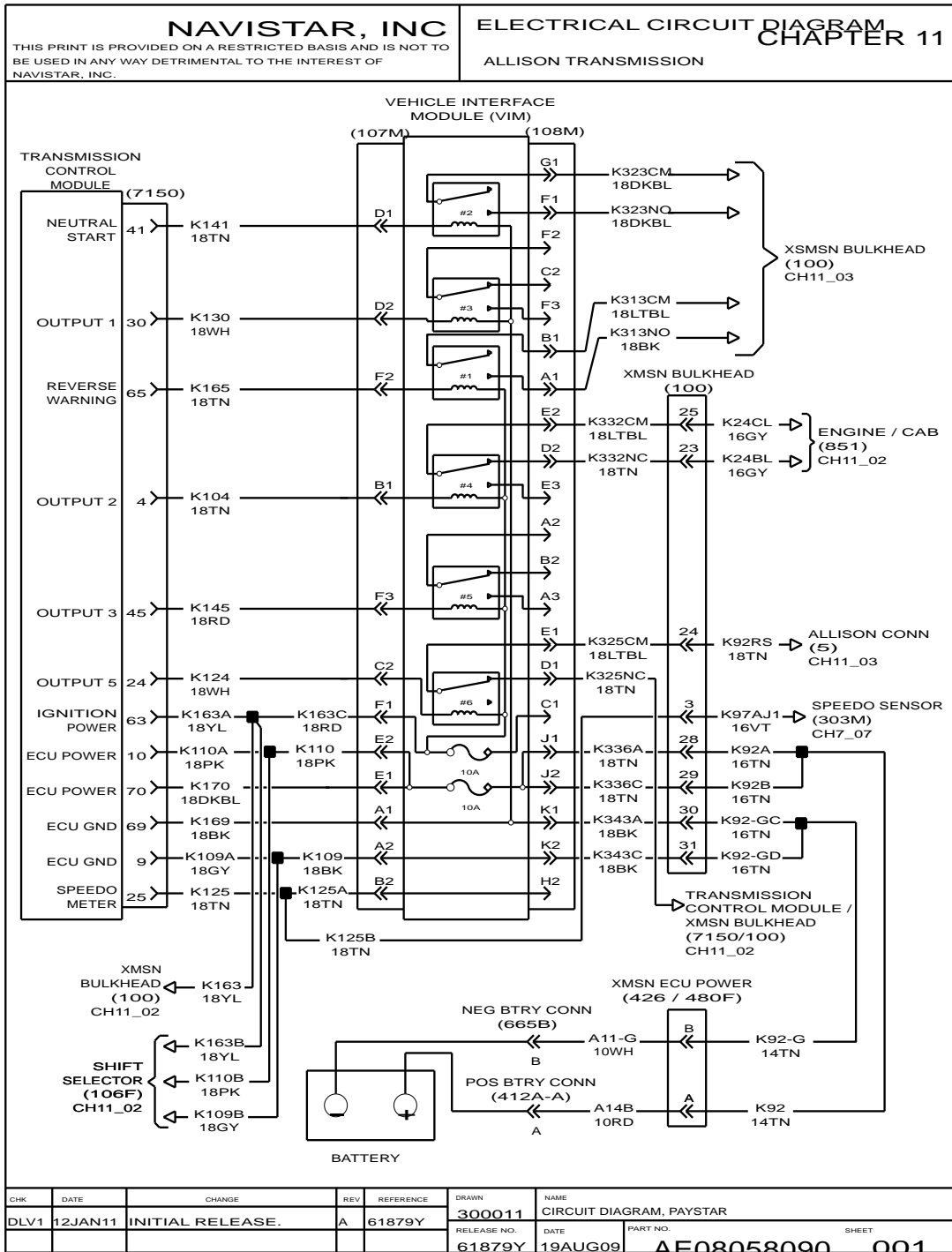


Figure 160 Allison Transmission

11.2. ALLISON TRANSMISSION (CONT.), P. 1A

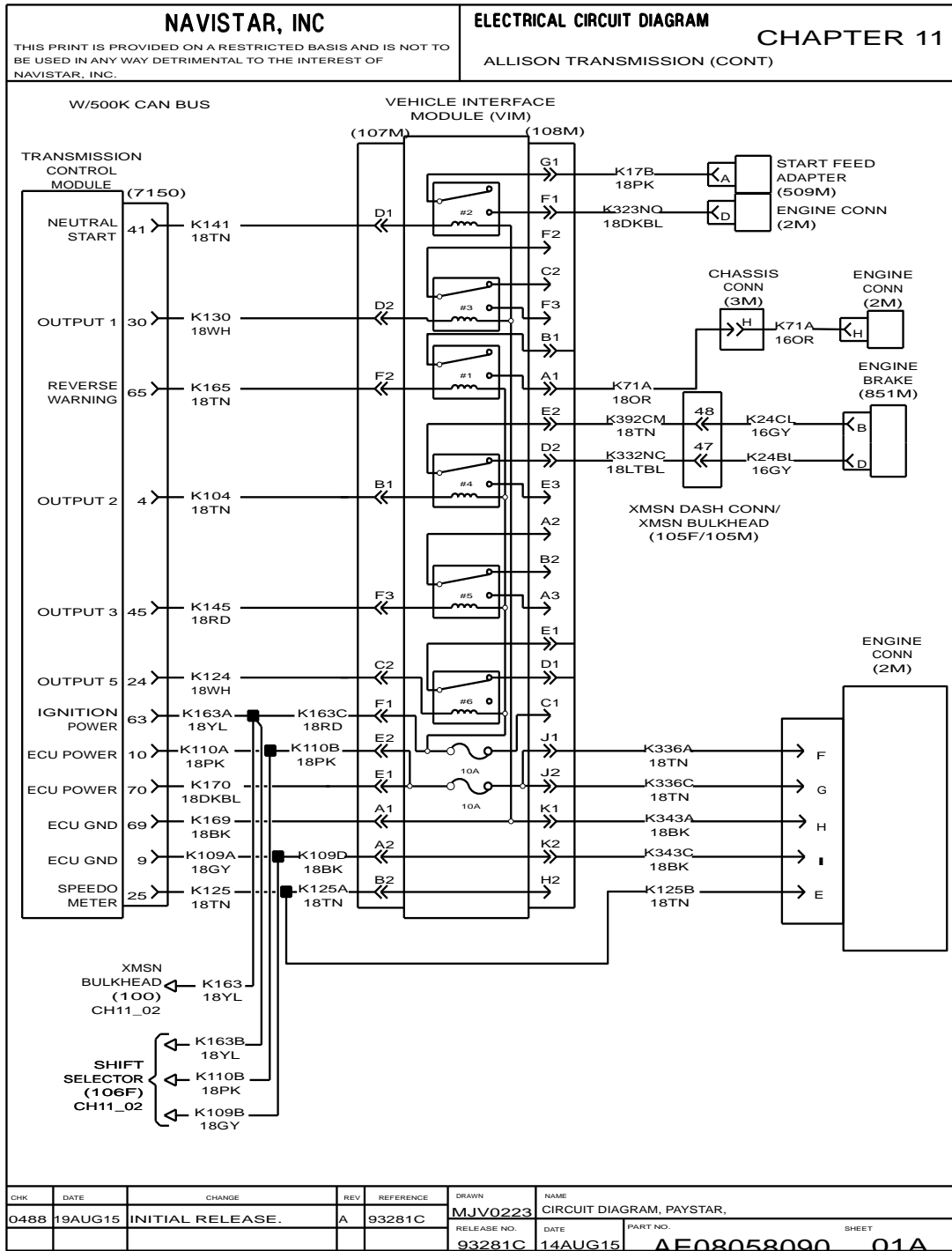


Figure 161 Allison Transmission (Cont.)

11.3. ALLISON TRANSMISSION (CONT.), P. 2

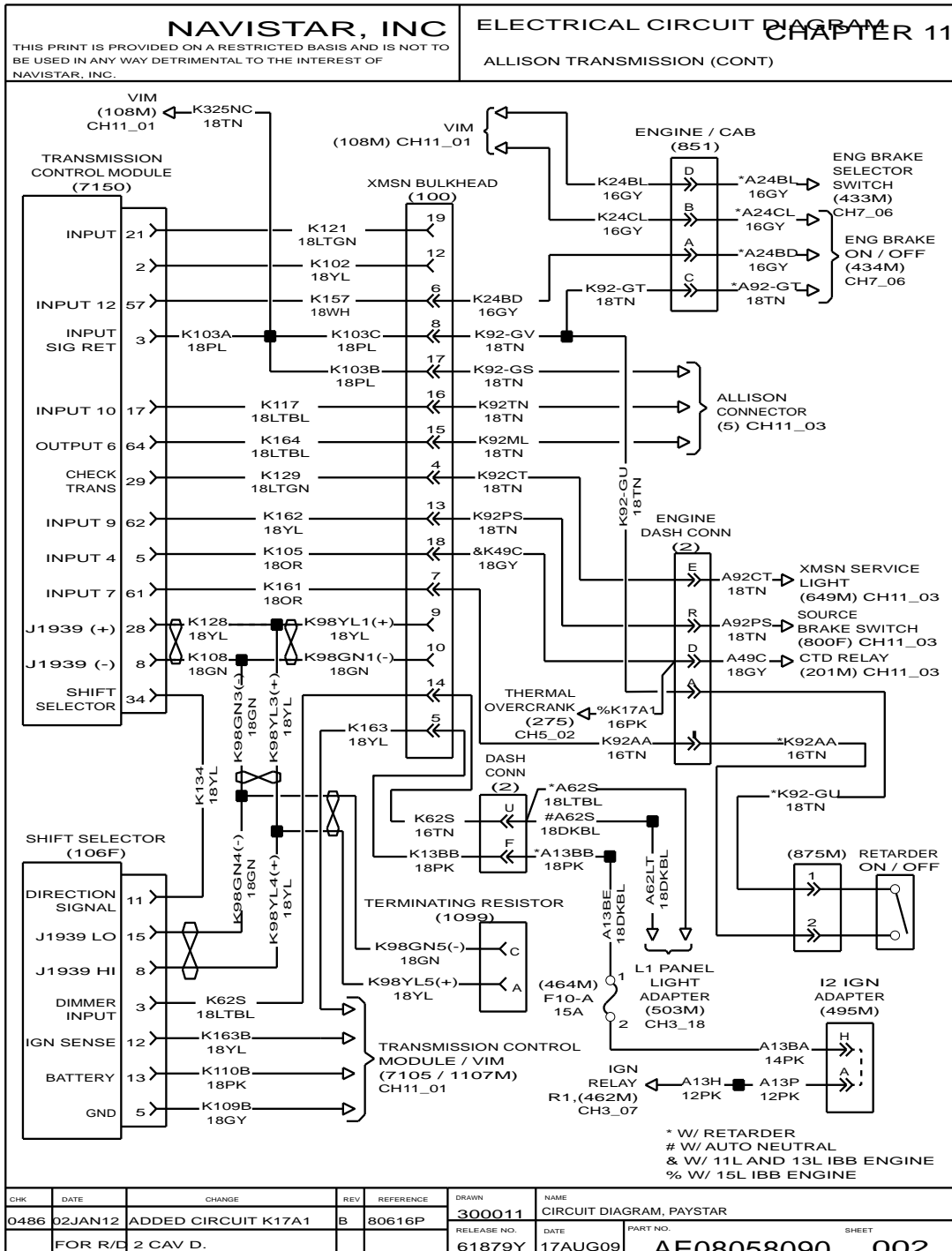


Figure 162 Allison Transmission (Cont.)

11.4. ALLISON TRANSMISSION (CONT.), P. 3

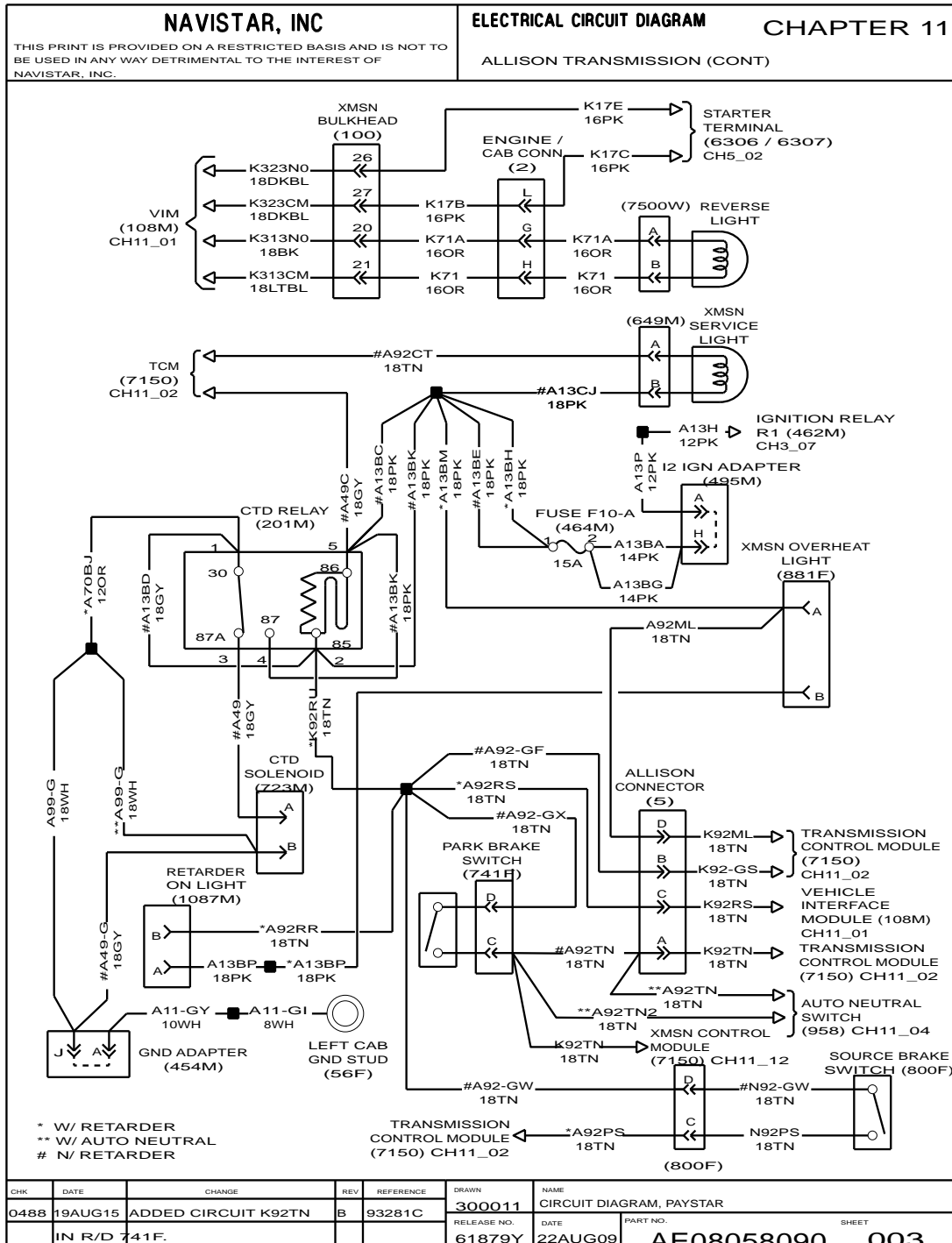


Figure 163 Allison Transmission (Cont.)

11.5. ALLISON TRANSMISSION (CONT.), P. 3A

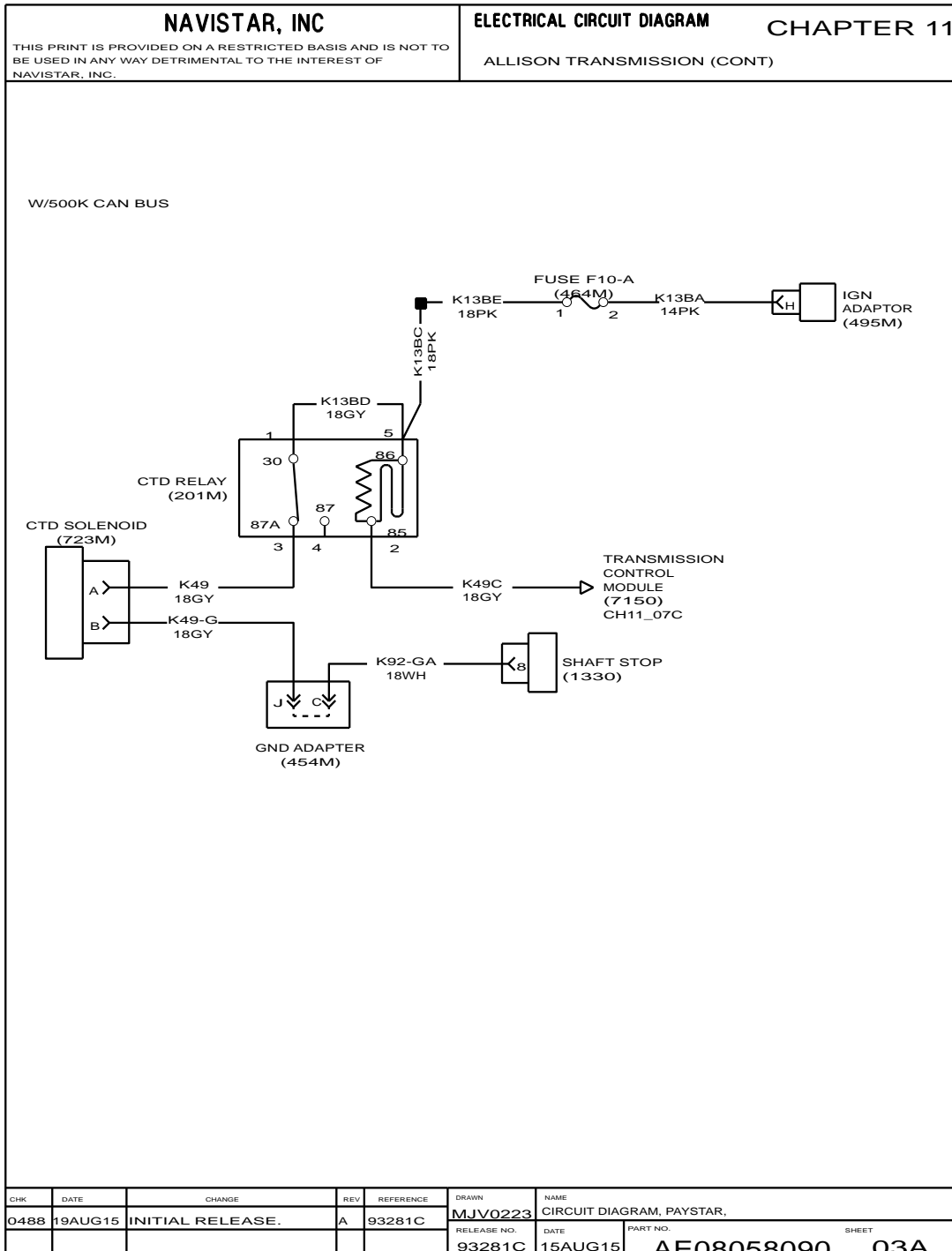


Figure 164 Allison Transmission (Cont.)

11.6. ALLISON TRANSMISSION WITH AUTO NEUTRAL, P. 4

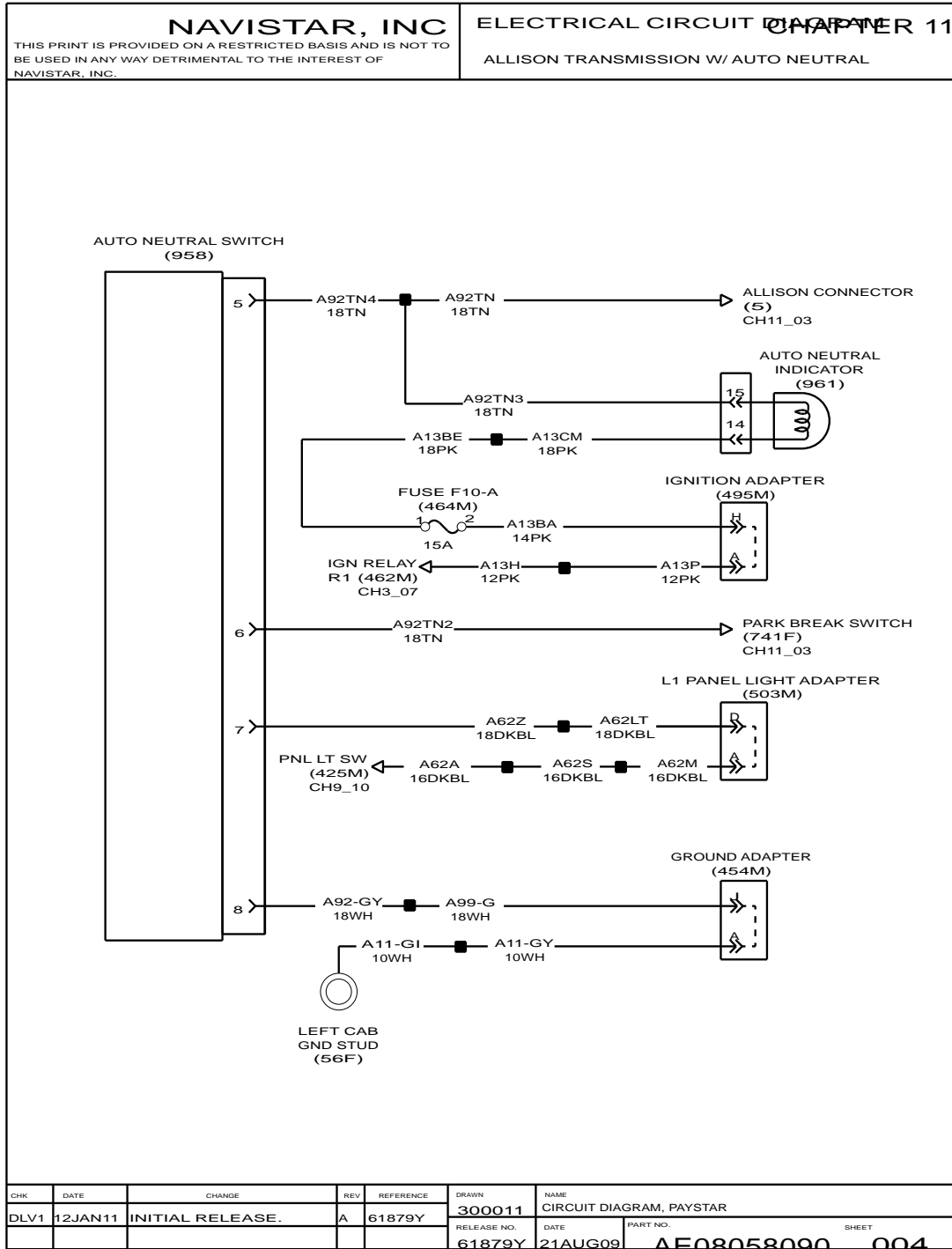


Figure 165 Allison Transmission with Auto Neutral

11.7. ALLISON TRANSMISSION WITH AUTO NEUTRAL (CONT.), P. 4A

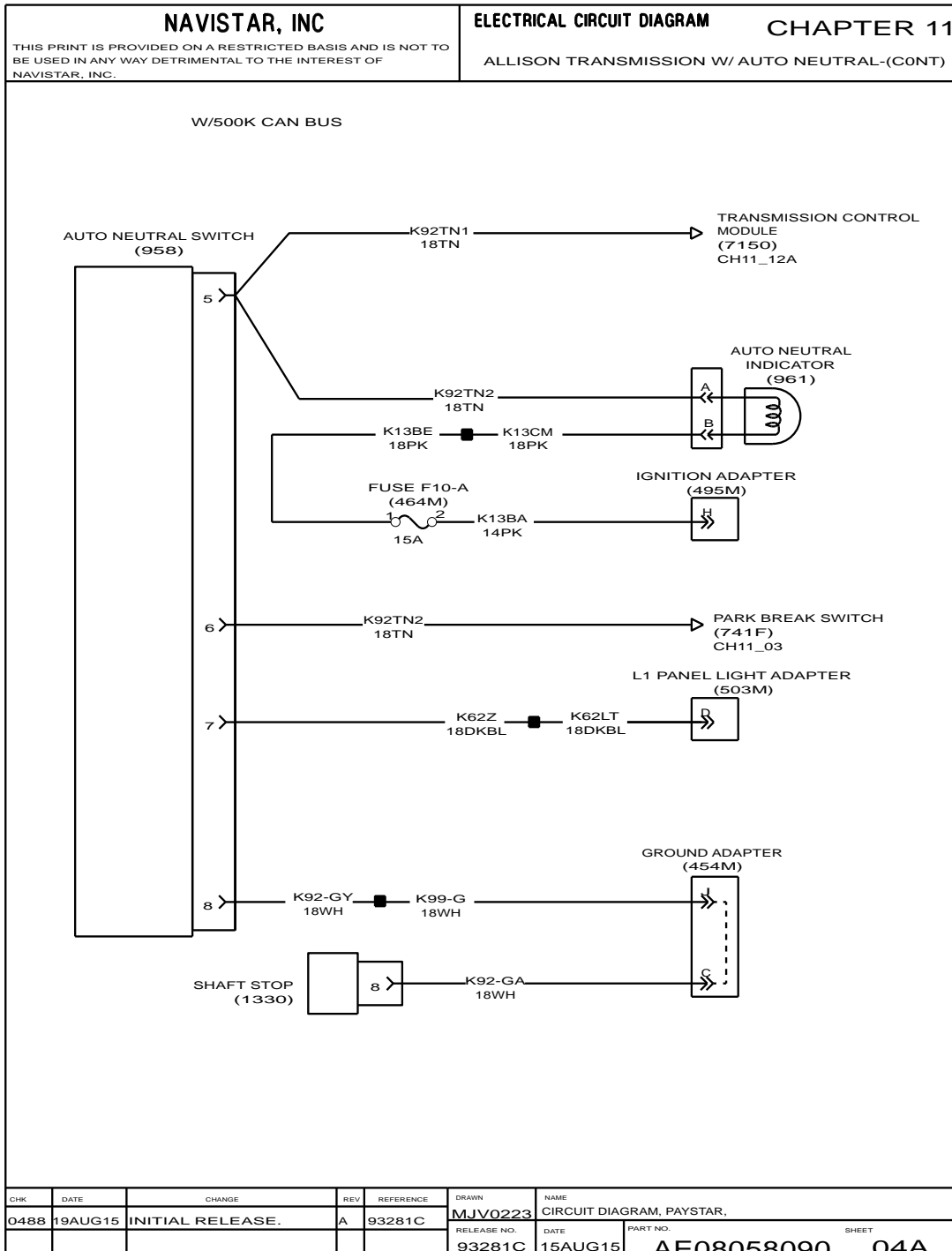


Figure 166 Allison Transmission with Auto Neutral (Cont.)



11.8. ALLISON TRANSMISSION WITH RETARDER, P. 5

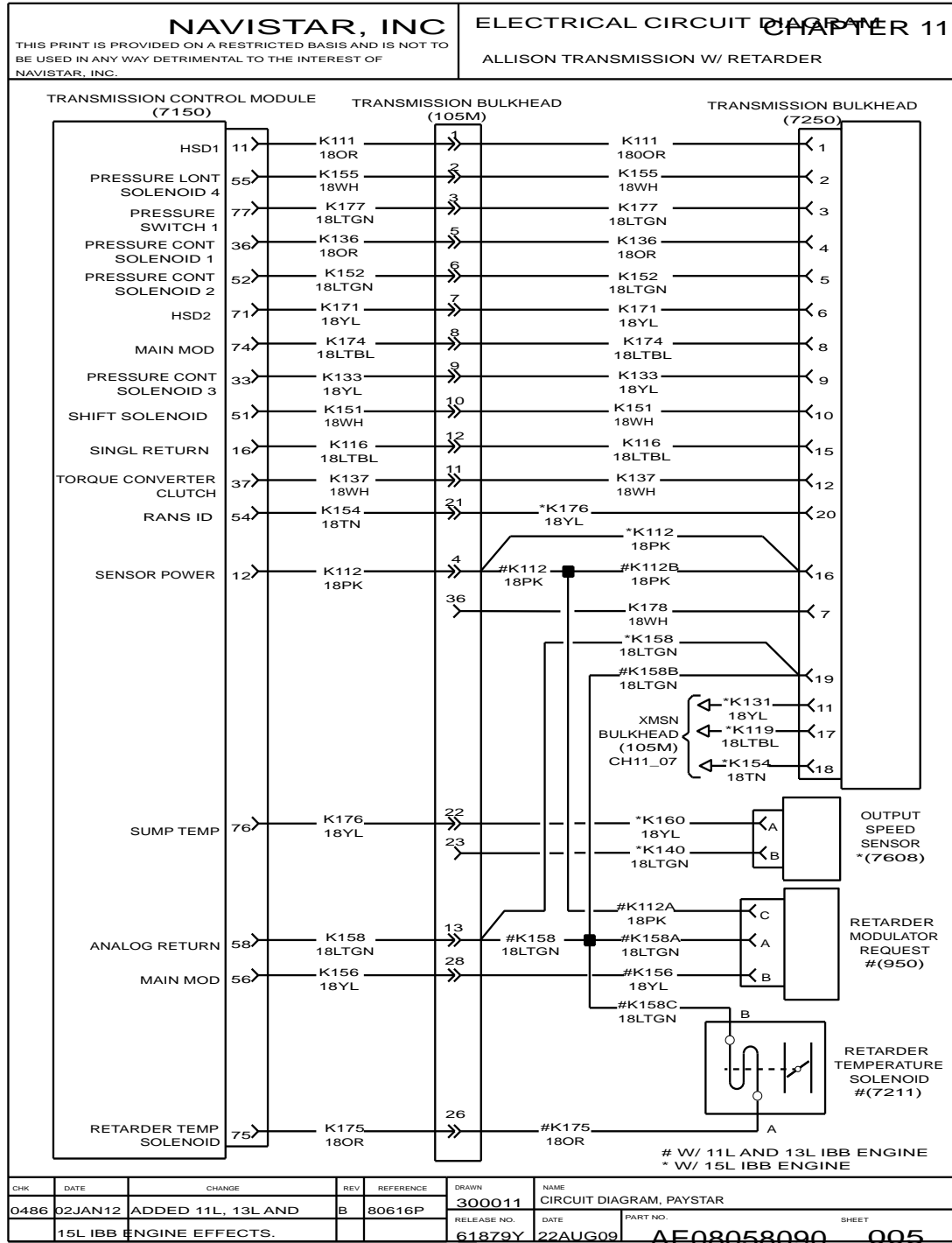


Figure 167 Allison Transmission with Retarder

11.9. ALLISON TRANSMISSION WITH RETARDER (CONT.), P. 6

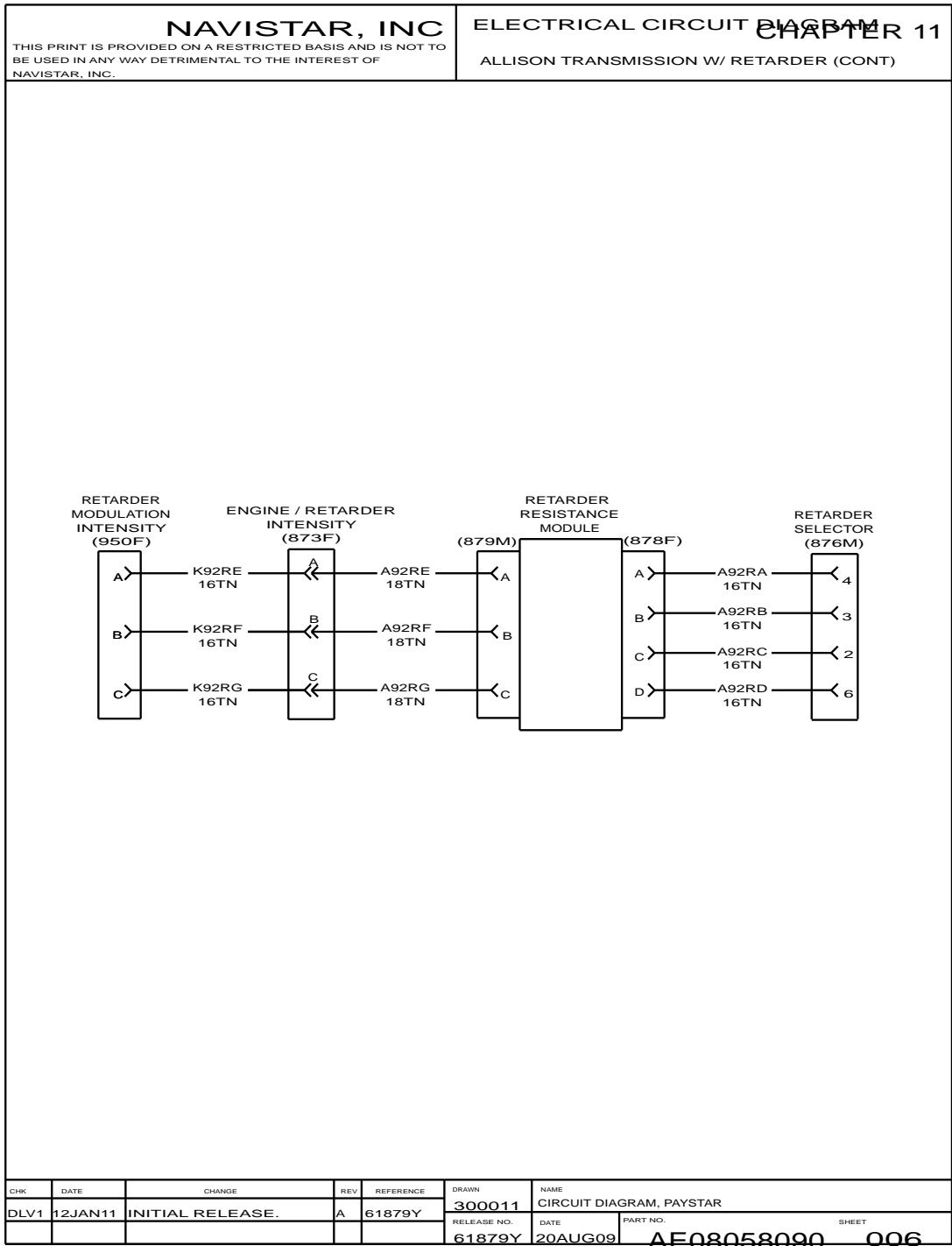


Figure 168 Allison Transmission with Retarder (Cont.)

11.10. ALLISON TRANSMISSION WITH RETARDER (CONT.), P. 7

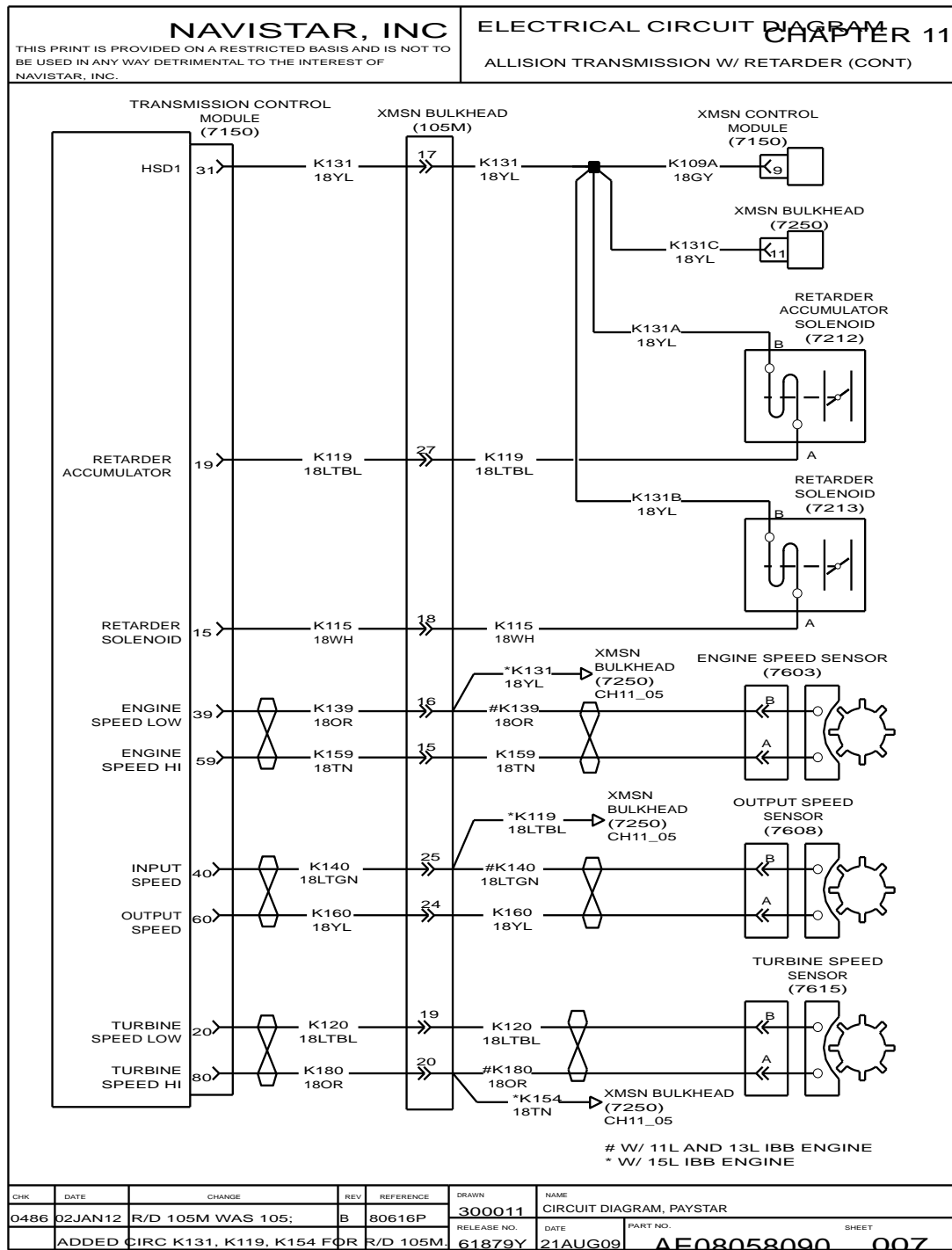


Figure 169 Allison Transmission with Retarder (Cont.)

11.11. ALLISON TRANSMISSION WITH RETARDER (CONT.), P. 7A

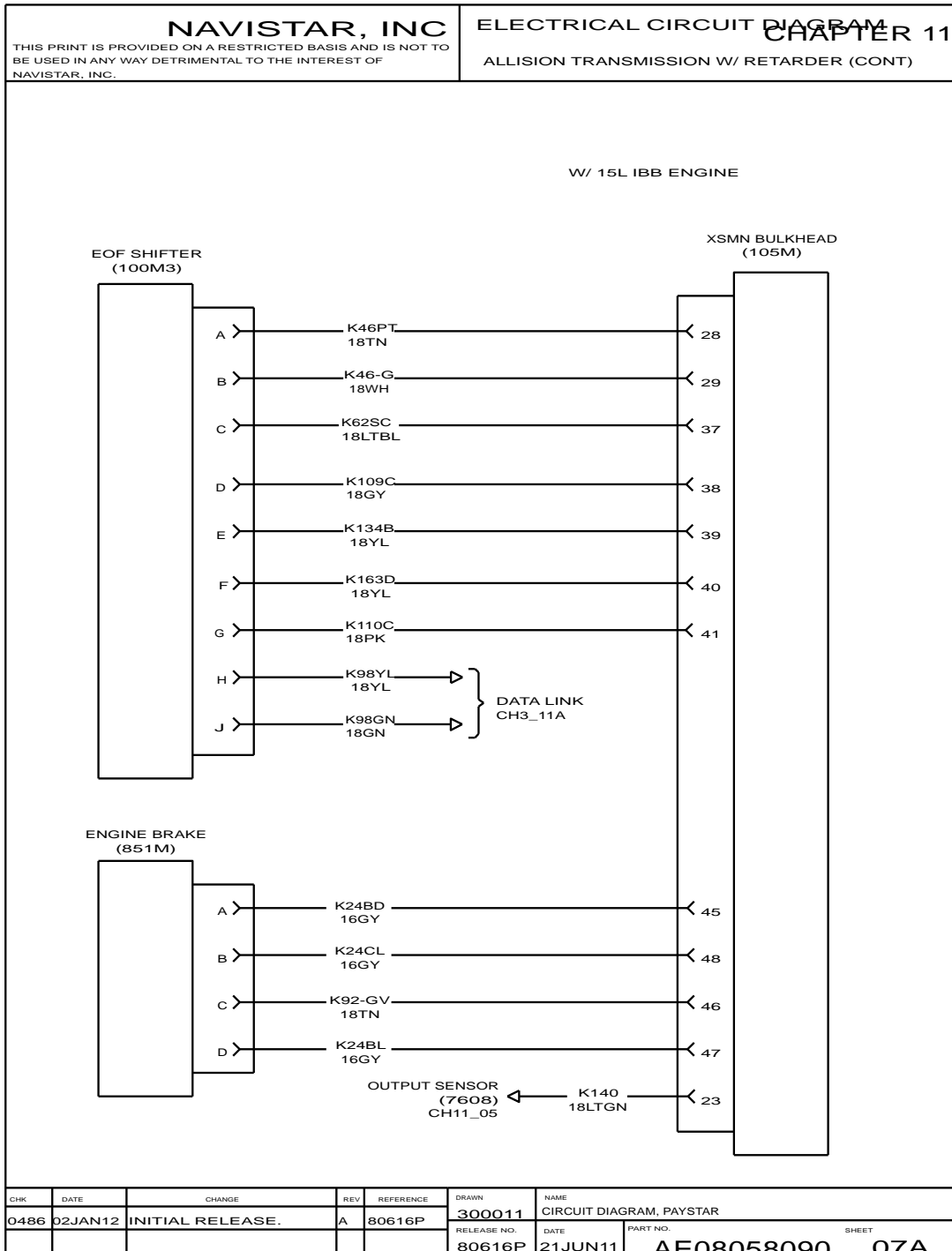


Figure 170 Allison Transmission with Retarder (Cont.)

11.12. ALLISON TRANSMISSION WITH RETARDER (CONT.), P. 7B

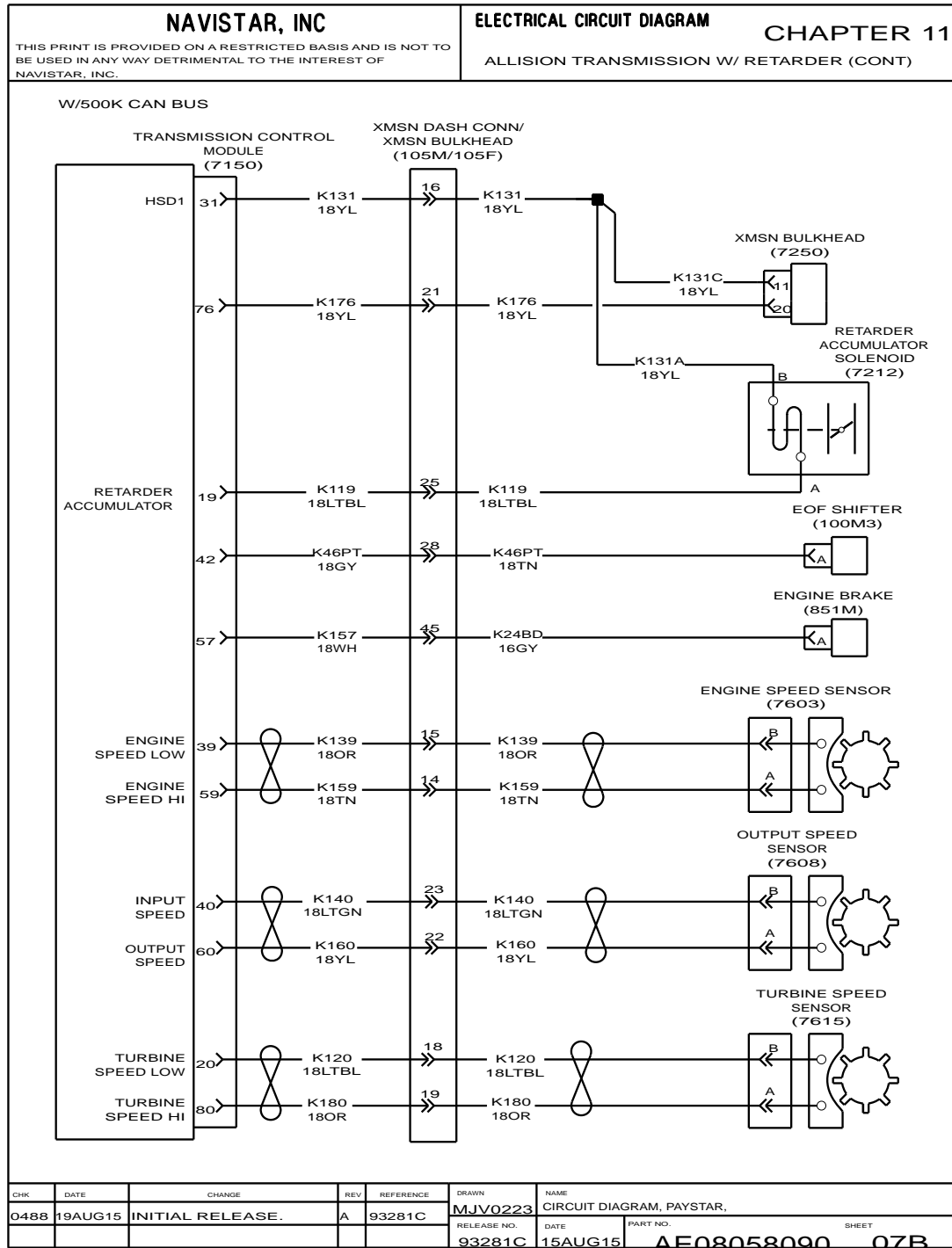


Figure 171 Allison Transmission with Retarder (Cont.)

11.13. ALLISON TRANSMISSION WITH RETARDER (CONT.), P. 7C

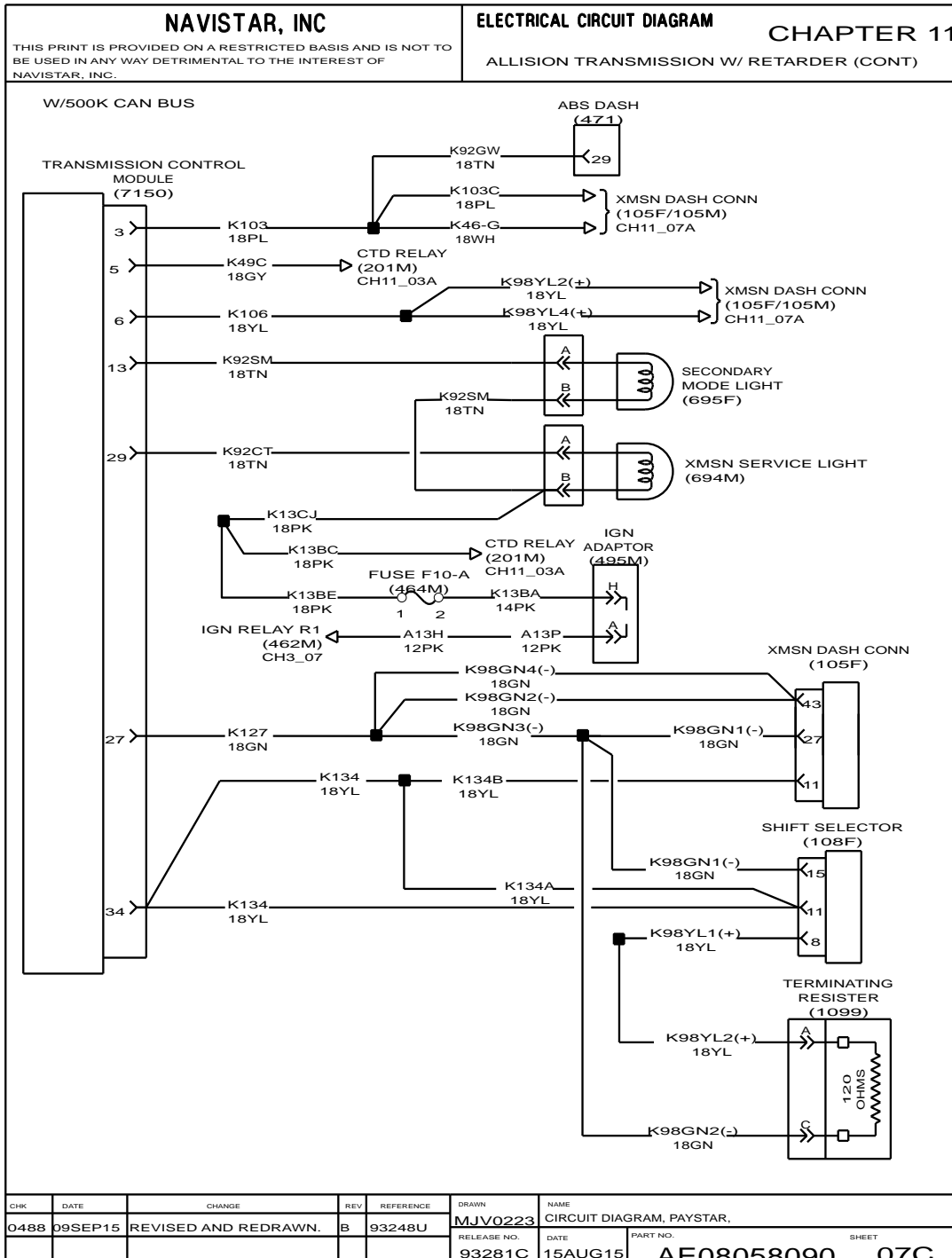


Figure 172 Allison Transmission with Retarder (Cont.)

11.14. ALLISON TRANSMISSION WITH RETARDER (CONT.), P. 7D

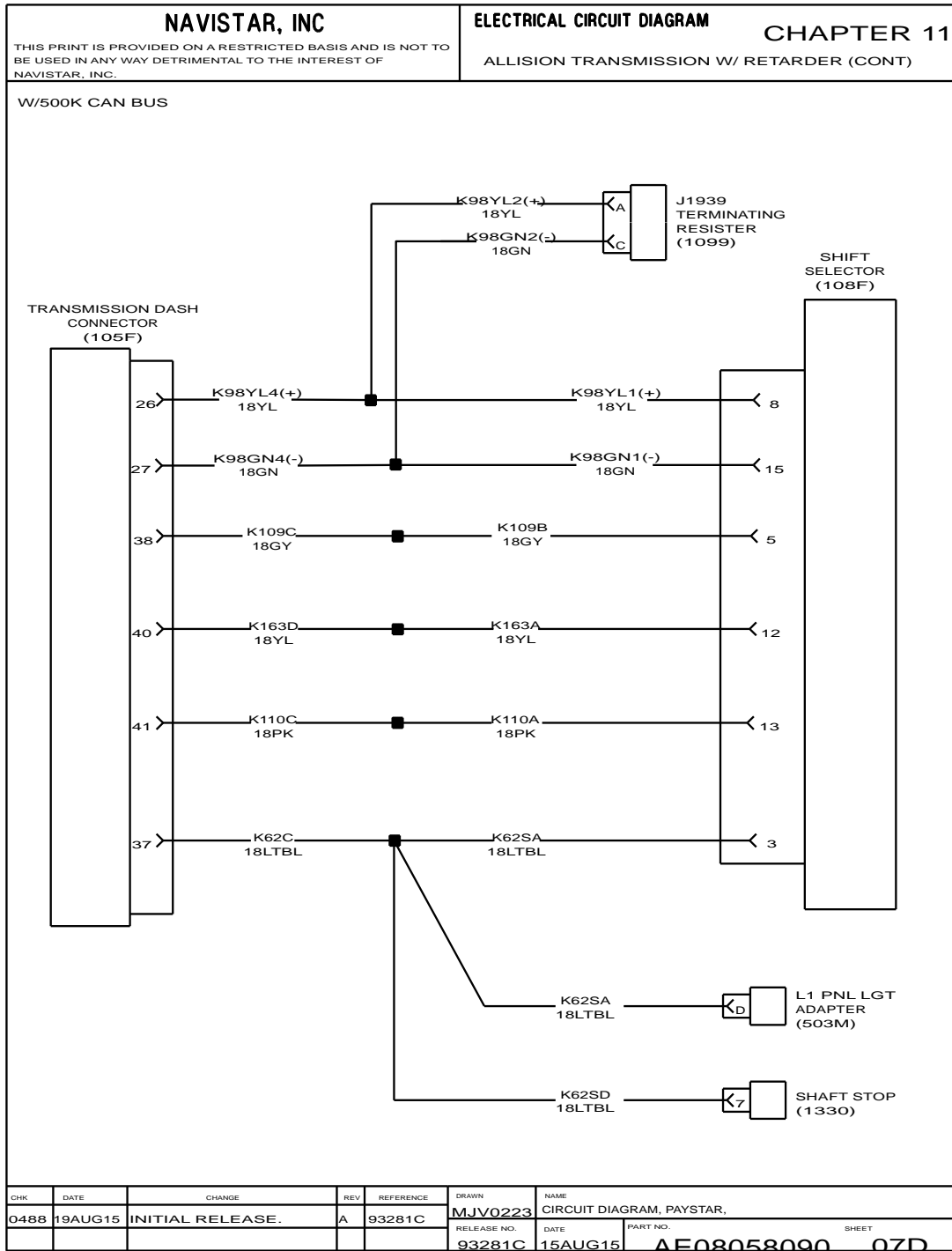


Figure 173 Allison Transmission with Retarder (Cont.)





11.16. EATON ULTRASHIFT PLUS GEN III TRANSMISSION, P. 8A

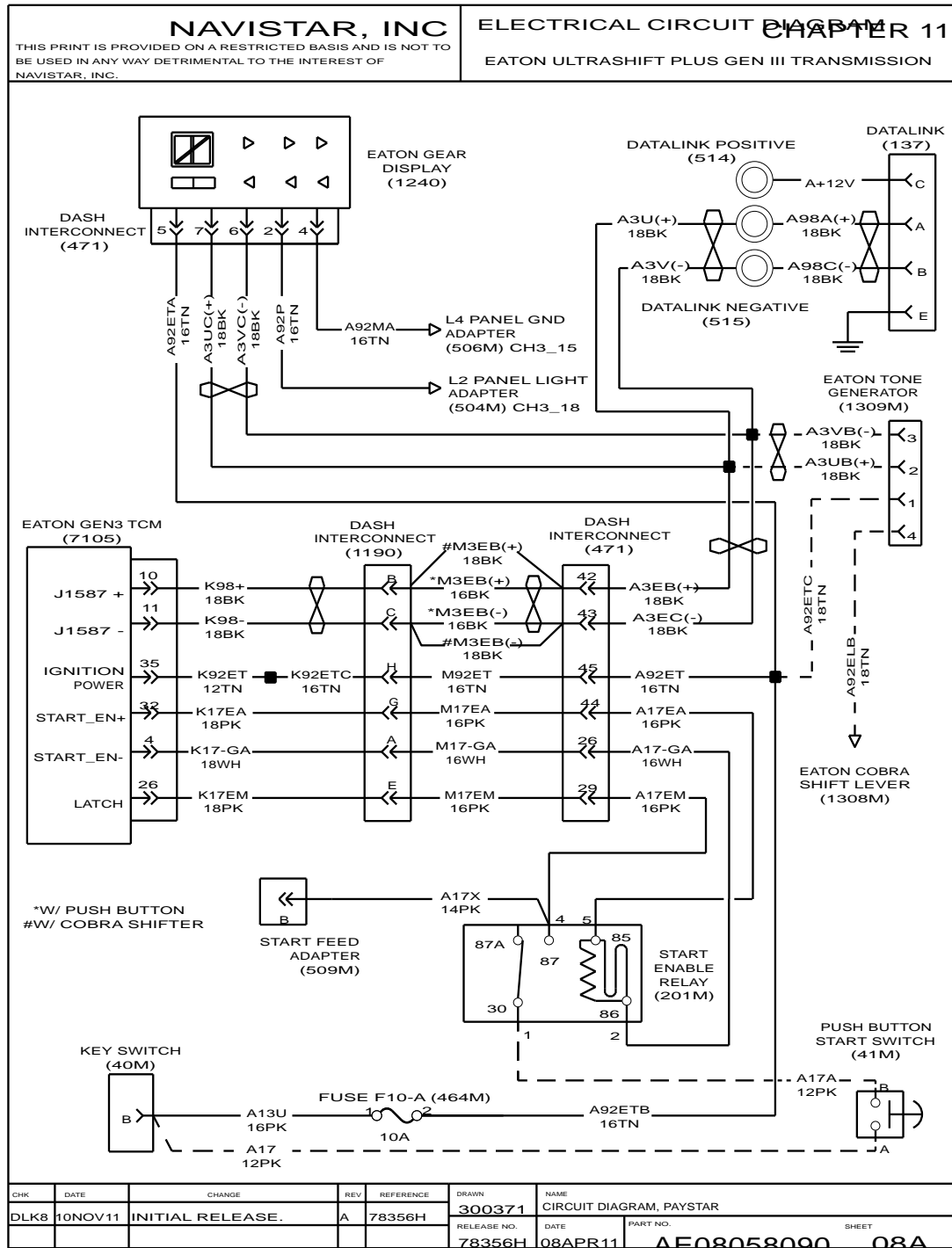


Figure 175 Eaton Ultrashift Plus GEN III Transmission

11.17. EATON ULTRASHIFT GEN III TRANSMISSION (CONT.), P. 9

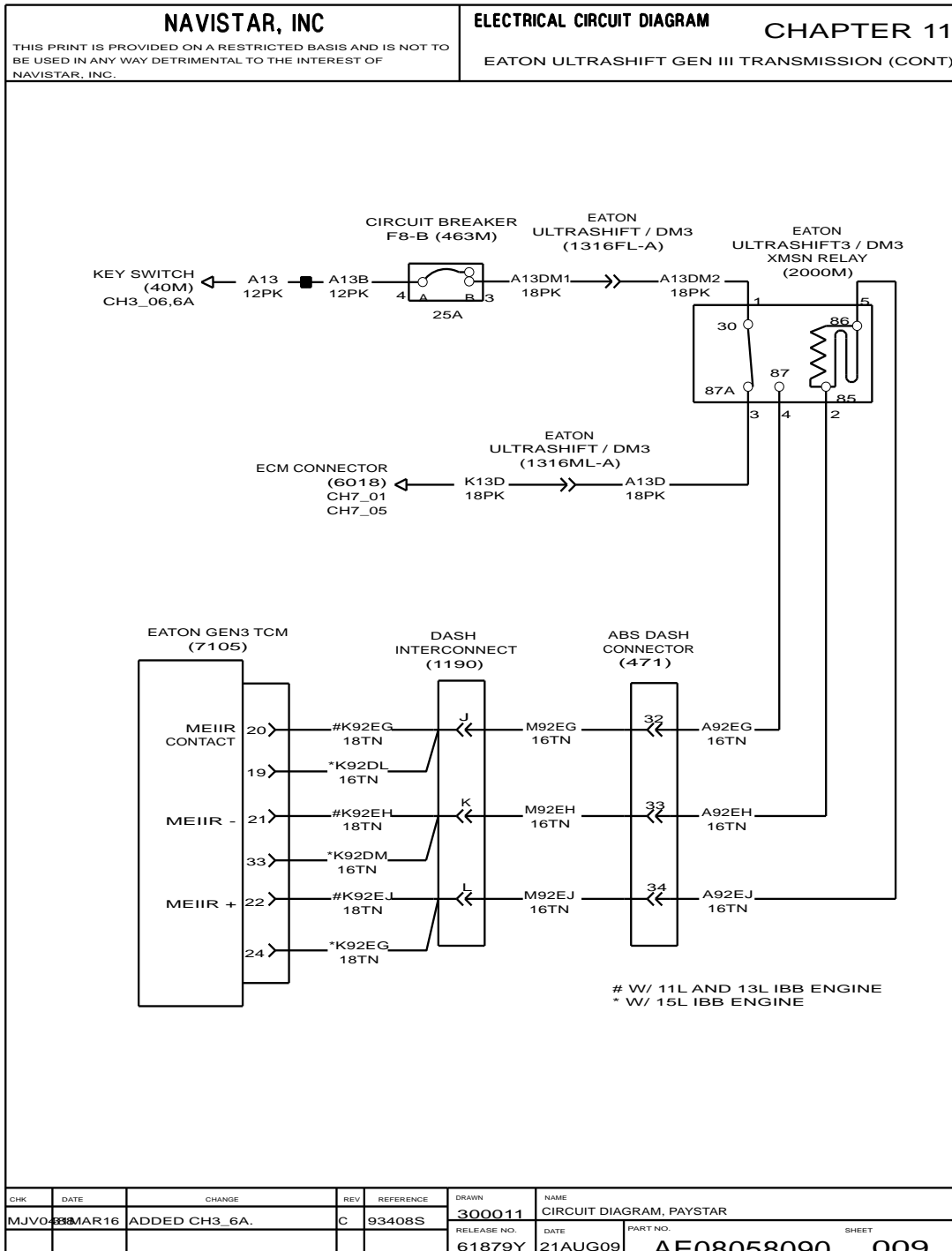


Figure 176 Eaton Ultrashift GEN III Transmission (Cont.)

11.18. EATON ULTRASHIFT PLUS GEN III TRANSMISSION (CONT.), P. 9A

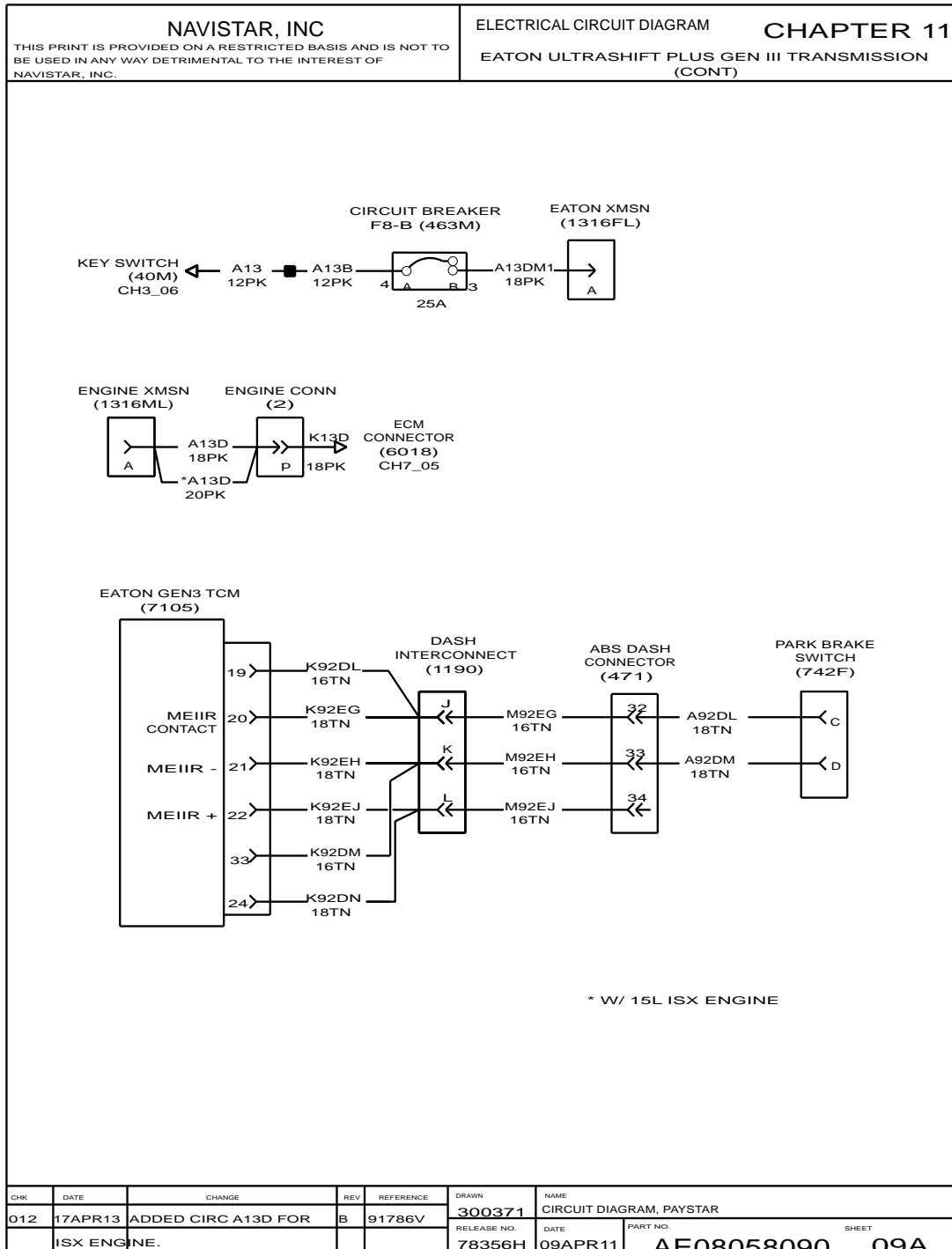


Figure 177 Eaton Ultrashift Plus GEN III Transmission (Cont.)

11.19. EATON ULTRASHIFT GEN III WITH PUSHBUTTON SHIFT, P. 10

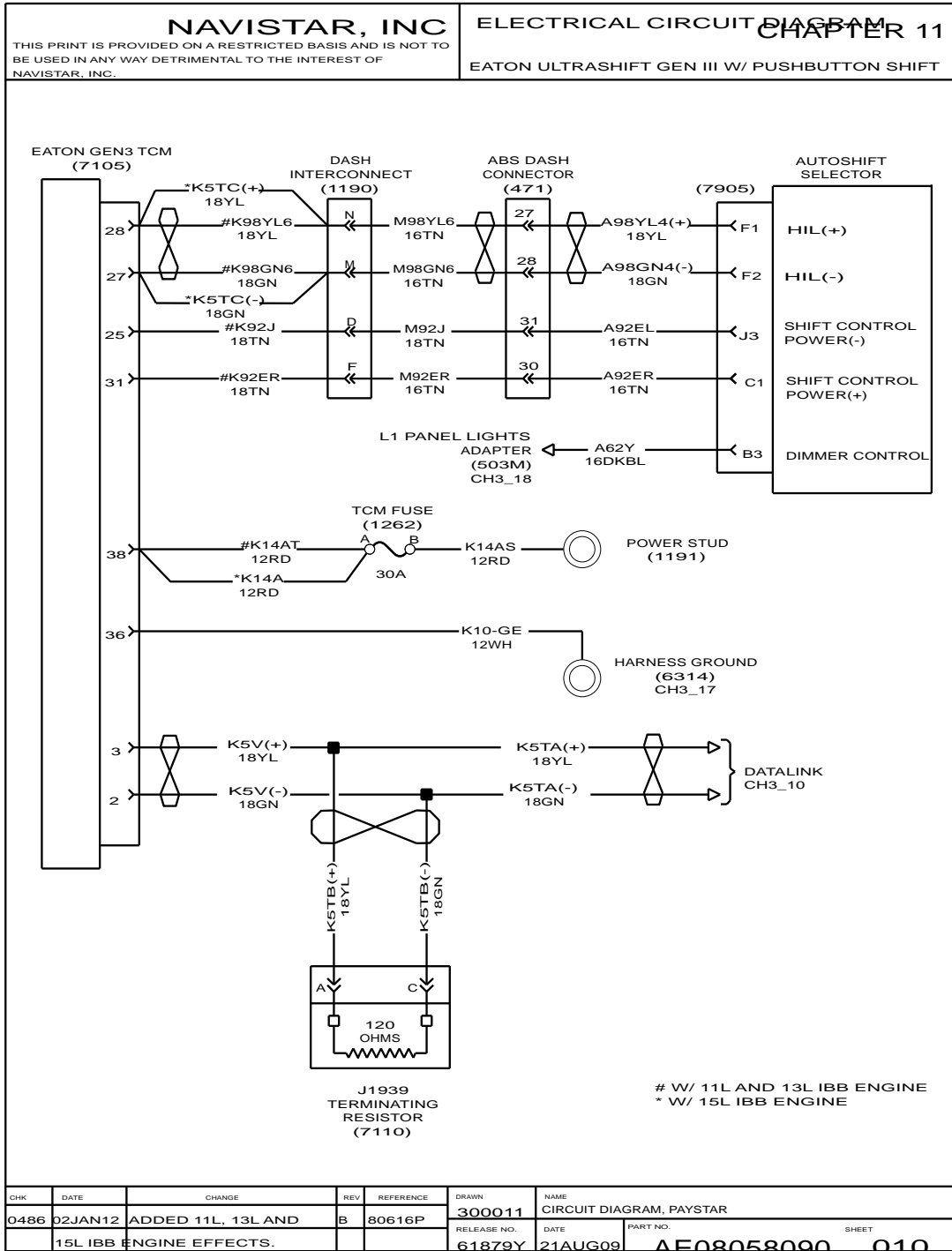


Figure 178 Eaton Ultrashift GEN III with Pushbutton Shift

11.20. EATON ULTRASHIFT GEN III WITH PUSHBUTTON SHIFT, P. 10A

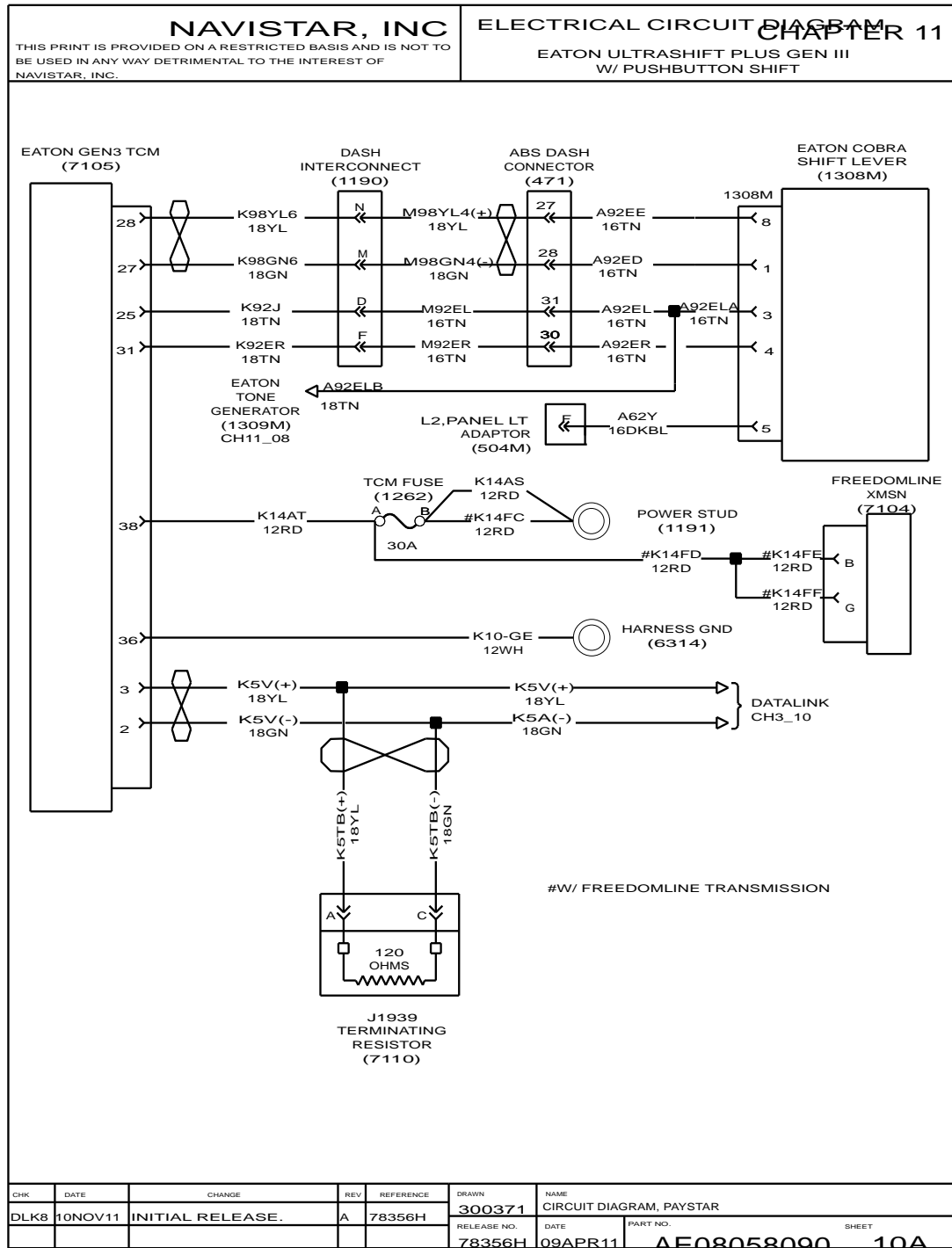


Figure 179 Eaton Ultrashift GEN III with Pushbutton Shift

11.21. AUTOSHIFT GEN III WITH COBRA SHIFTER, P. 11

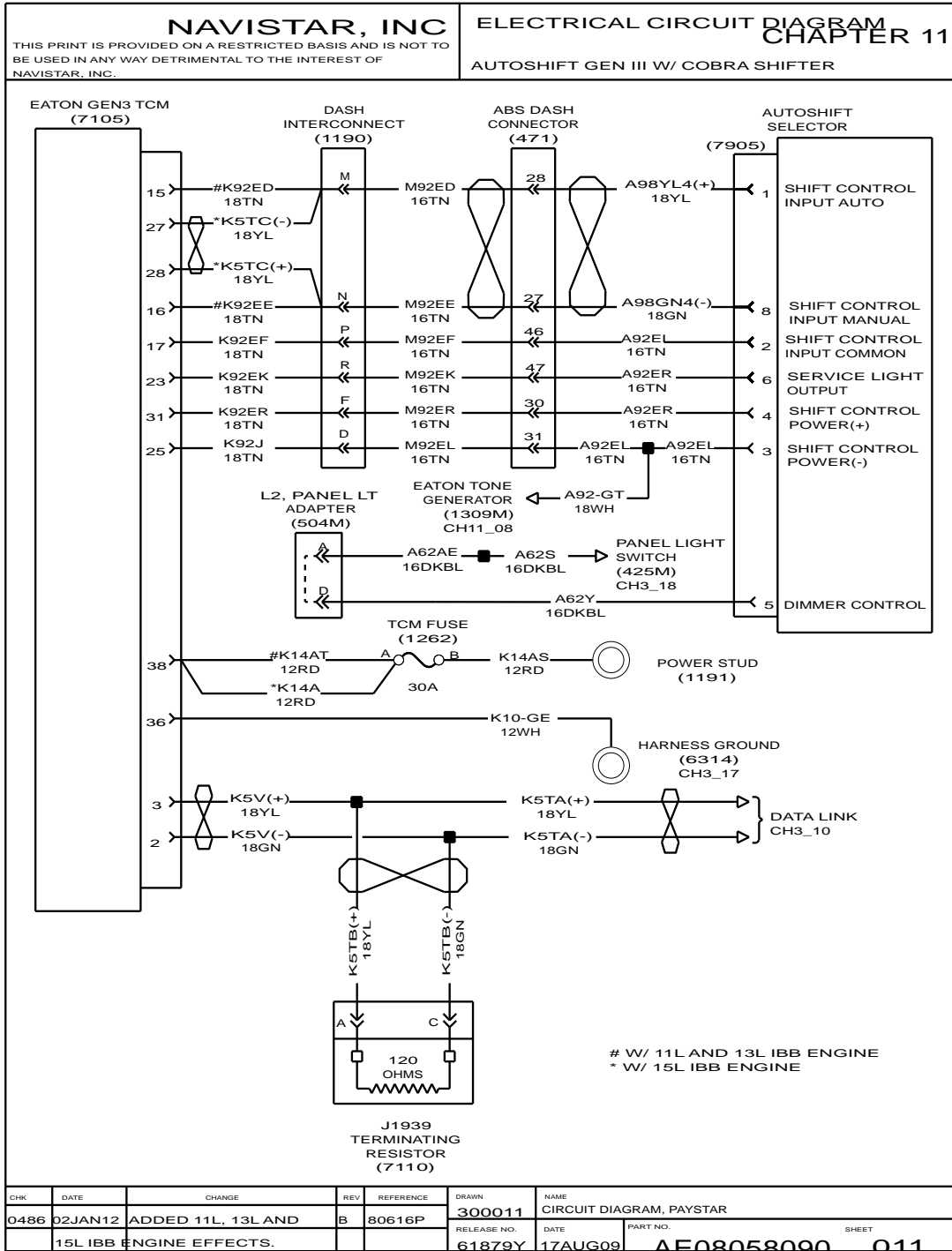


Figure 180 Autoshift GEN III with Cobra Shifter

11.22. EATON ULTRASHIFT PLUS GEN III WITH COBRA SHIFTER, P. 11A

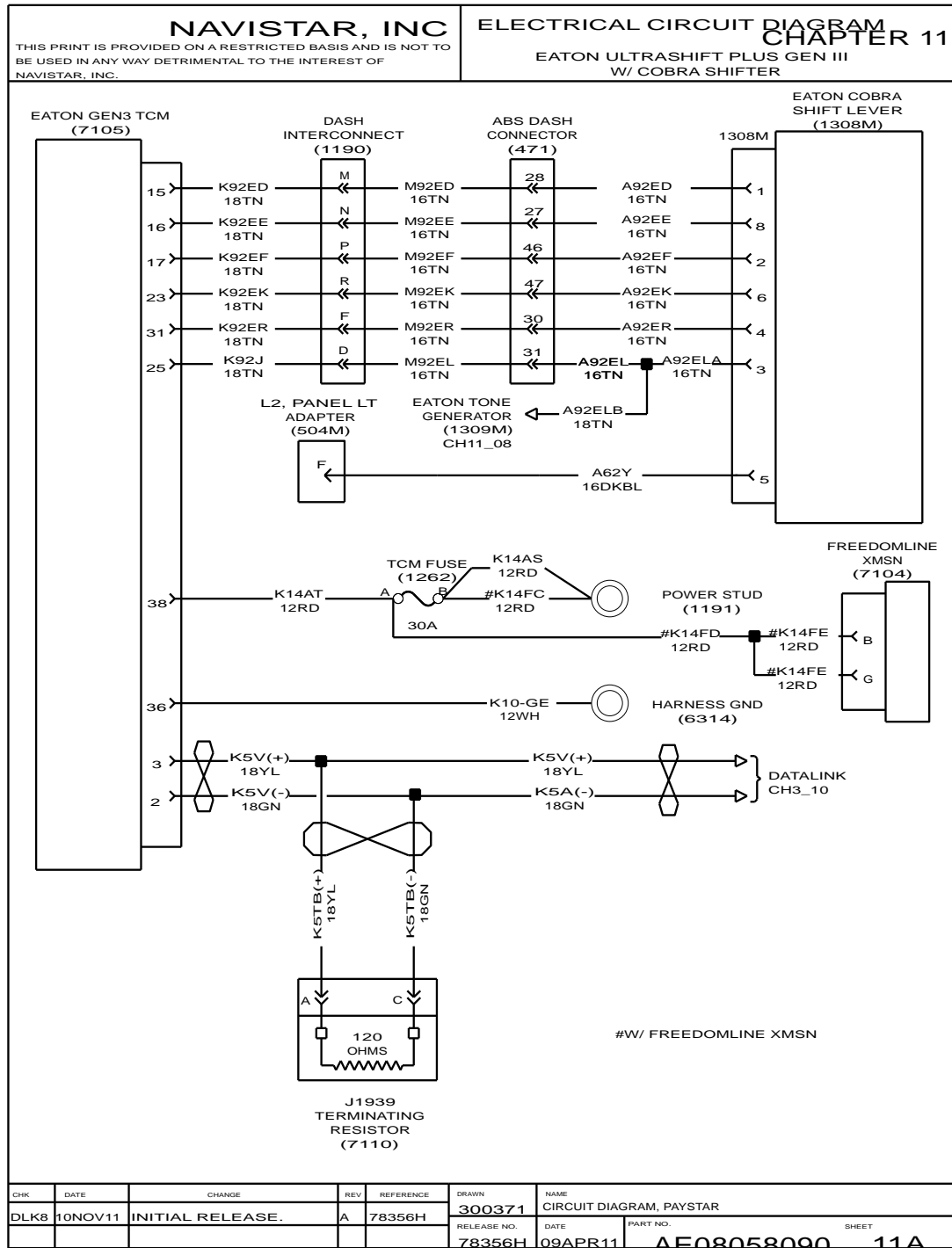


Figure 181 Eaton Ultrashift Plus Gen III with Cobra Shifter

11.23. ALLISON TRANSMISSION WITH RETARDER WITH ISX ENGINE, P. 12

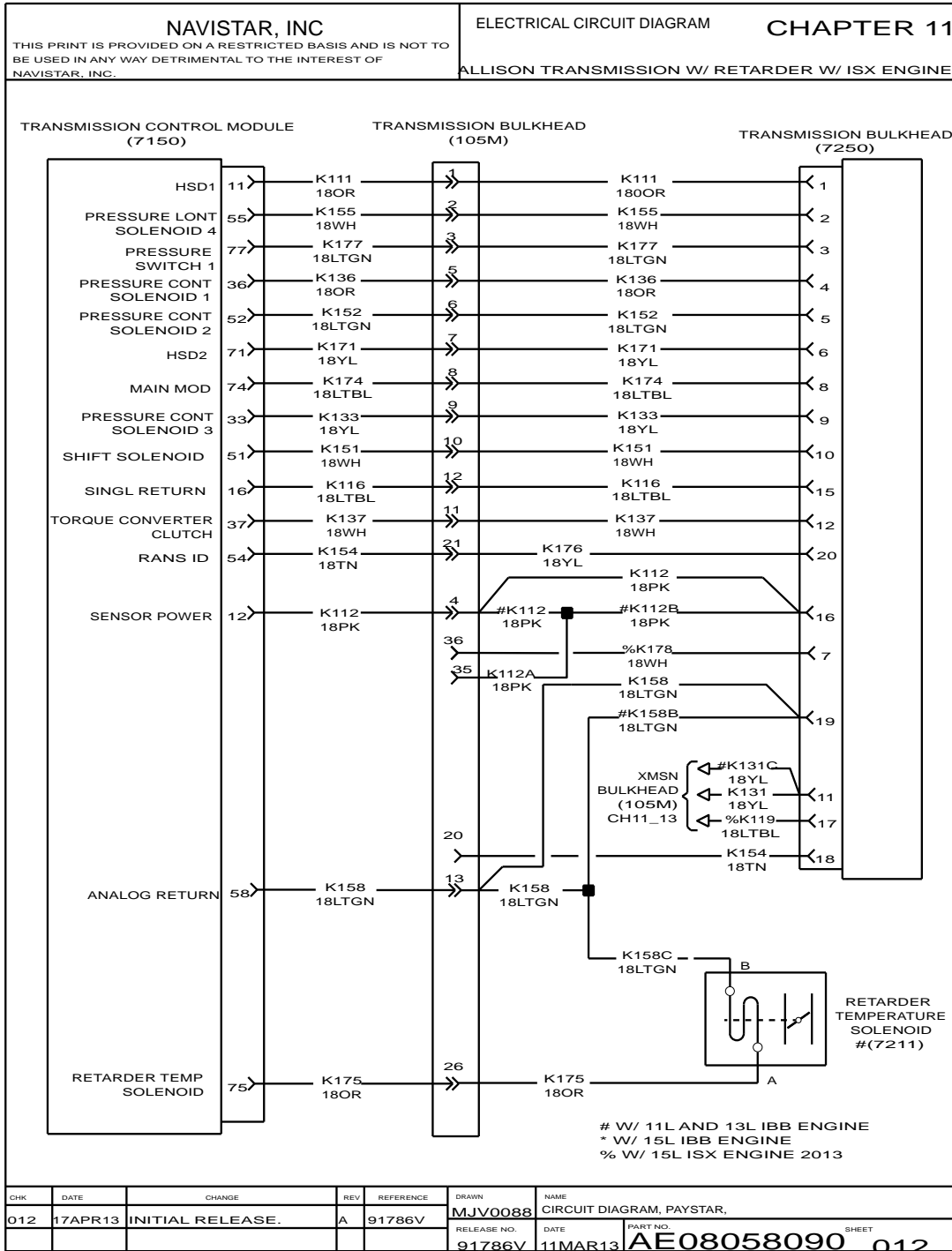


Figure 182 Allison Transmission with Retarder with ISX Engine



11.24. ALLISON TRANSMISSION WITH 500K CAN BUS, P. 12A

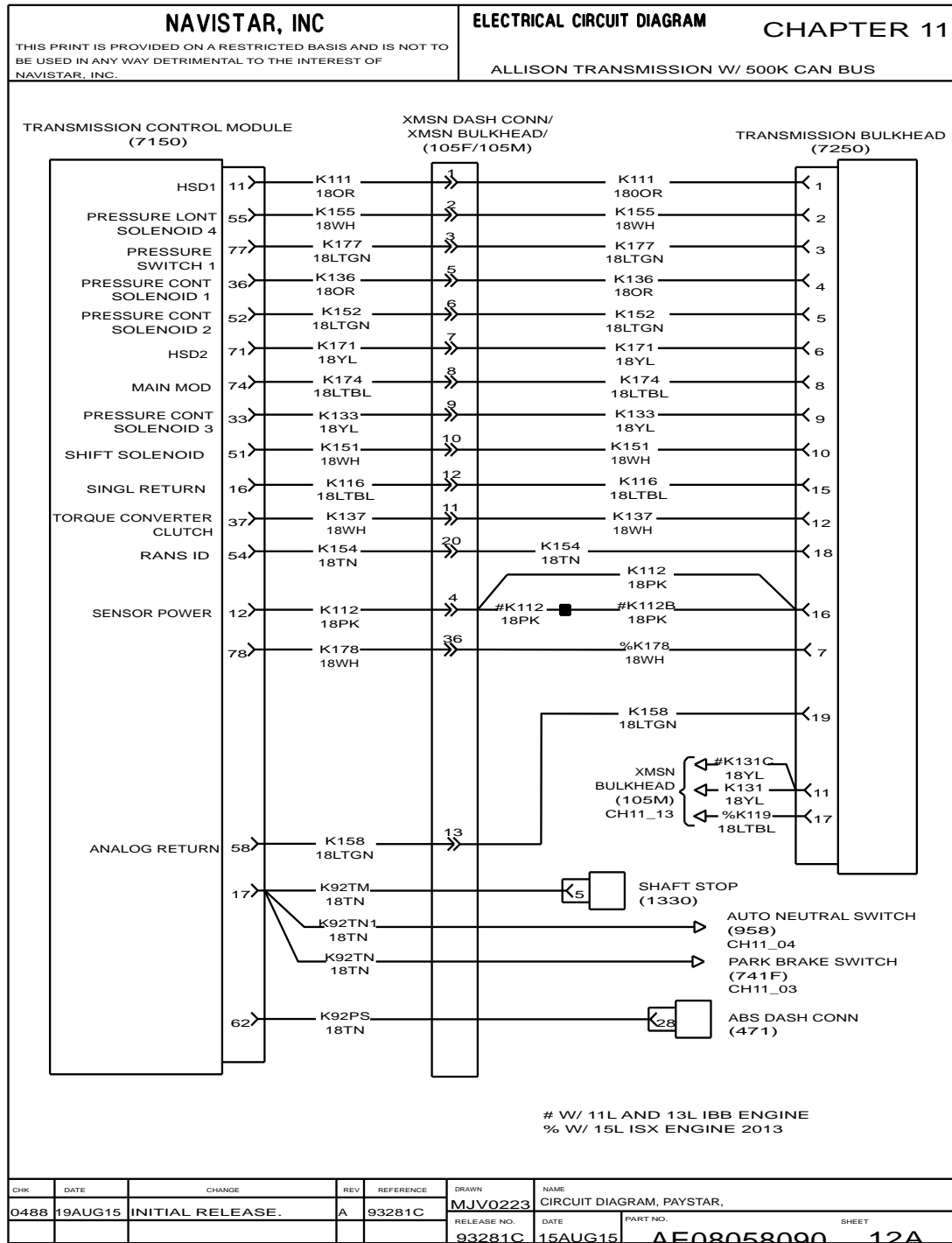


Figure 183 Allison Transmission with 500K Can Bus

11.25. ALLISON TRANSMISSION WITH RETARDER WITH ISX ENGINE (CONT.), P. 13

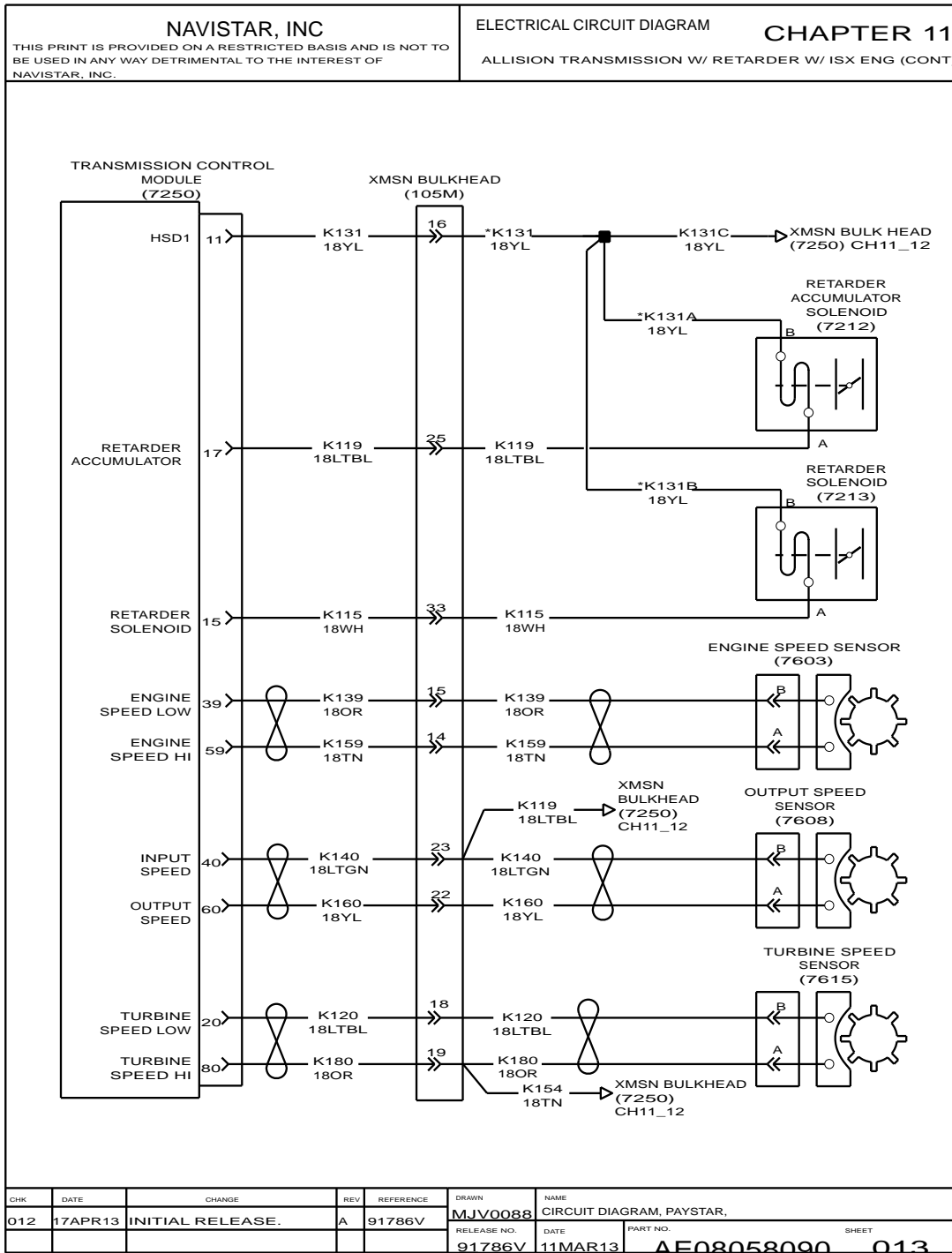


Figure 184 Allison Transmission with Retarder with ISX Engine (Cont.)

# HVAC (CHAPTER 12)

## 12.1. AIR CONDITIONER – CAB, P. 1

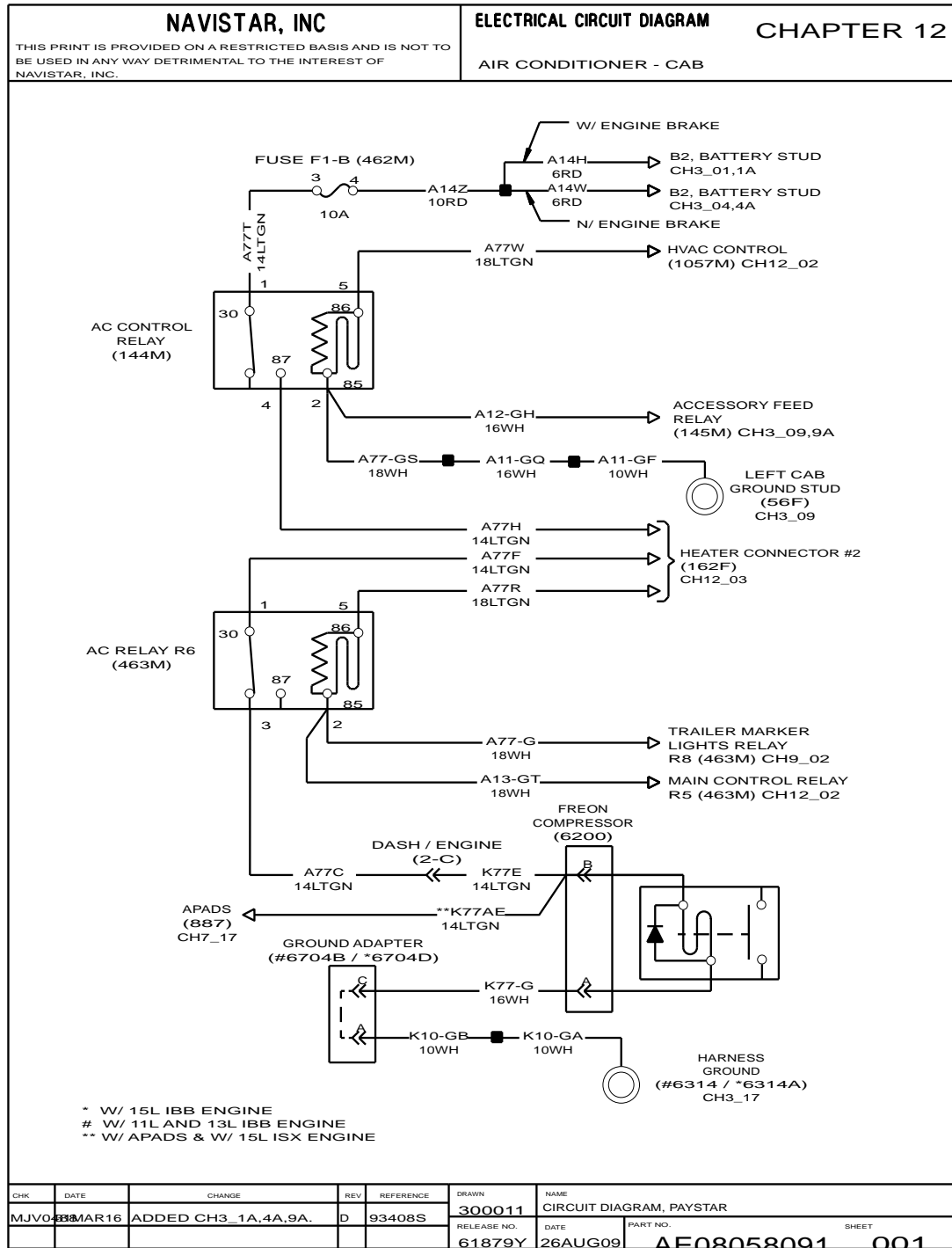


Figure 185 Air Conditioner – CAB

12.2. HEATER – CAB, P. 2

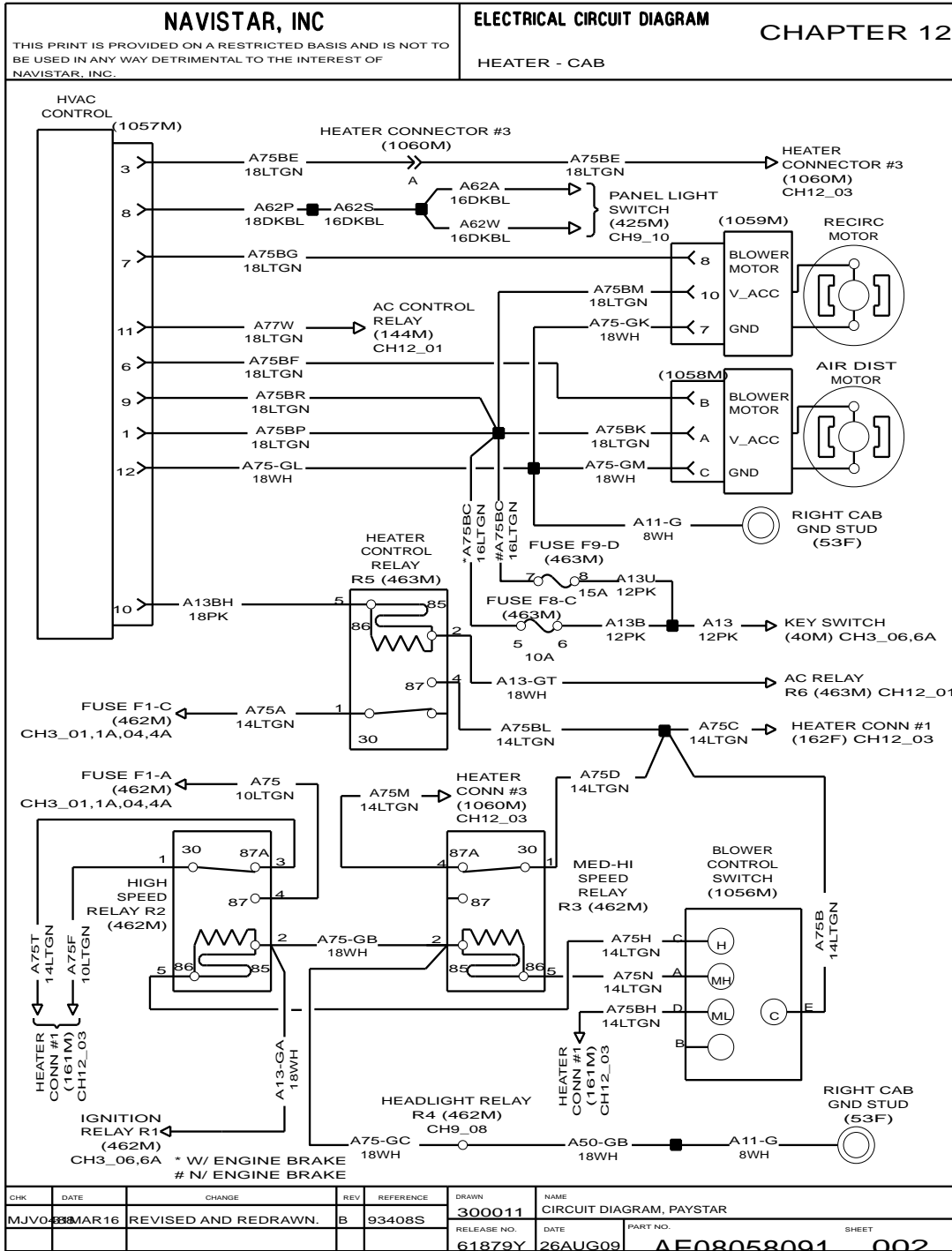


Figure 186 Heater – CAB

12.3. LOWERED HEATER – CAB, P. 3

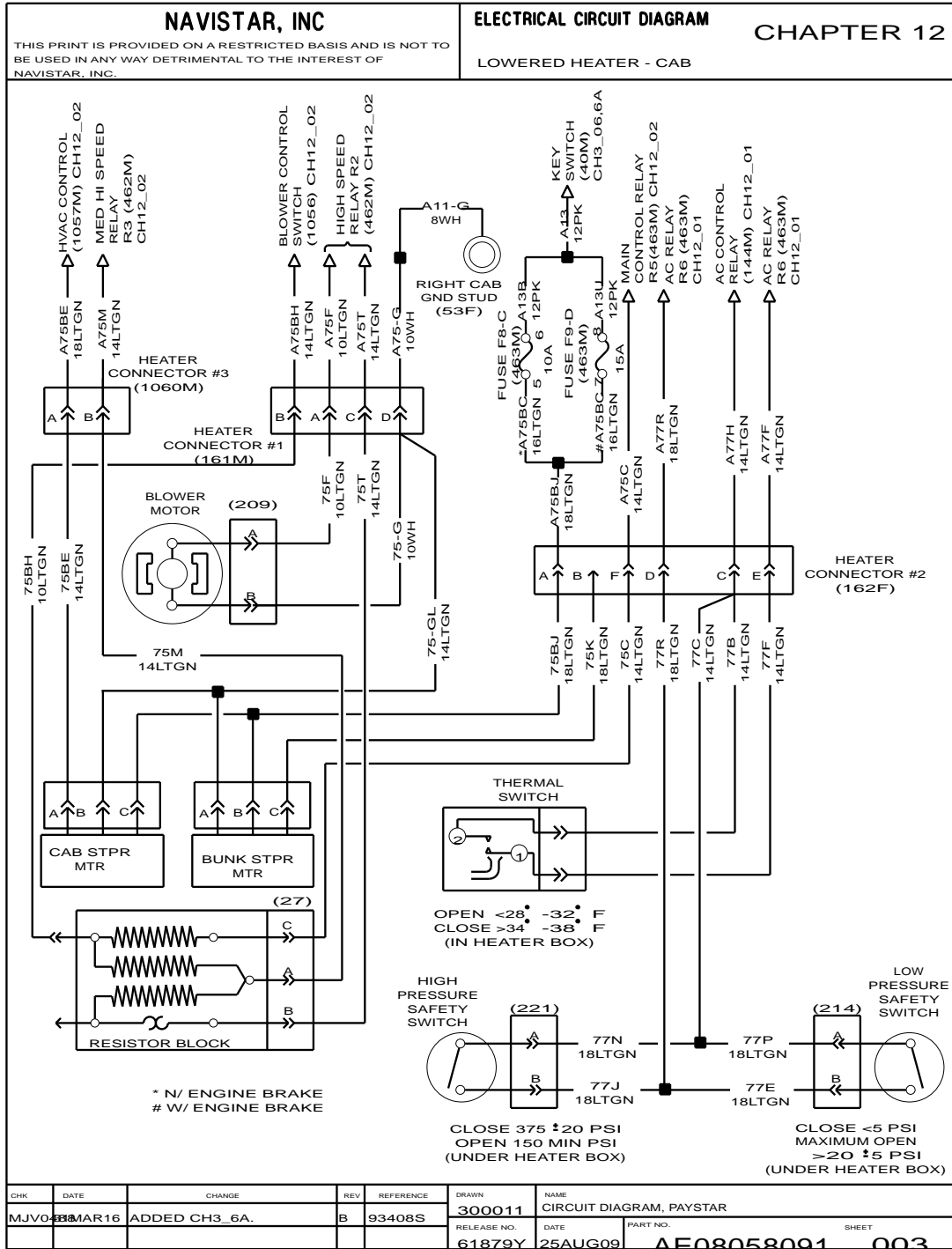


Figure 187 Lowered Heater – CAB

## CONNECTOR COMPOSITES (CHAPTER 13)

### 13.1. CONNECTOR COMPOSITES (1), P. 1

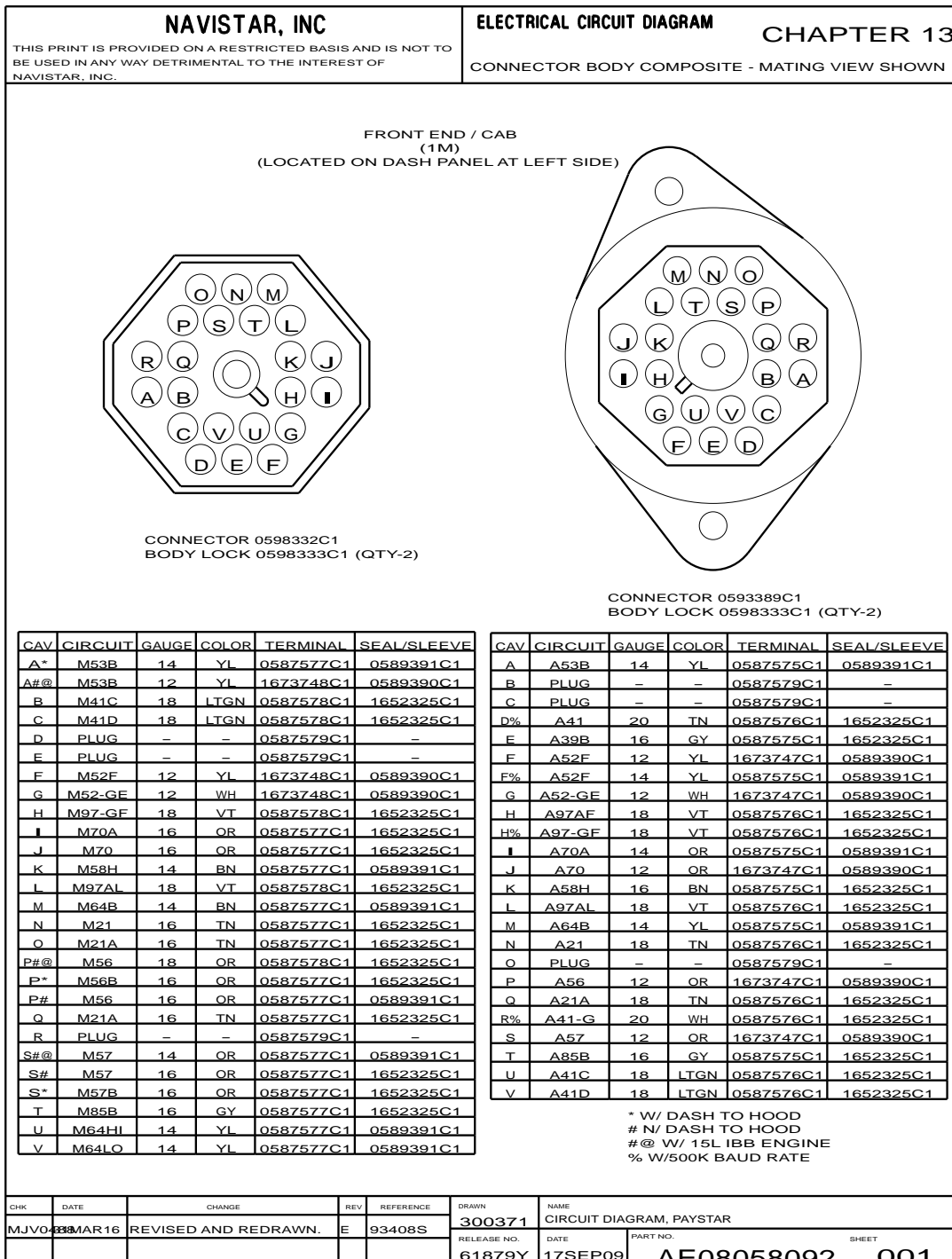


Figure 188 Connector Composites (1)

13.2. CONNECTOR COMPOSITES (2 / 2M), P. 2

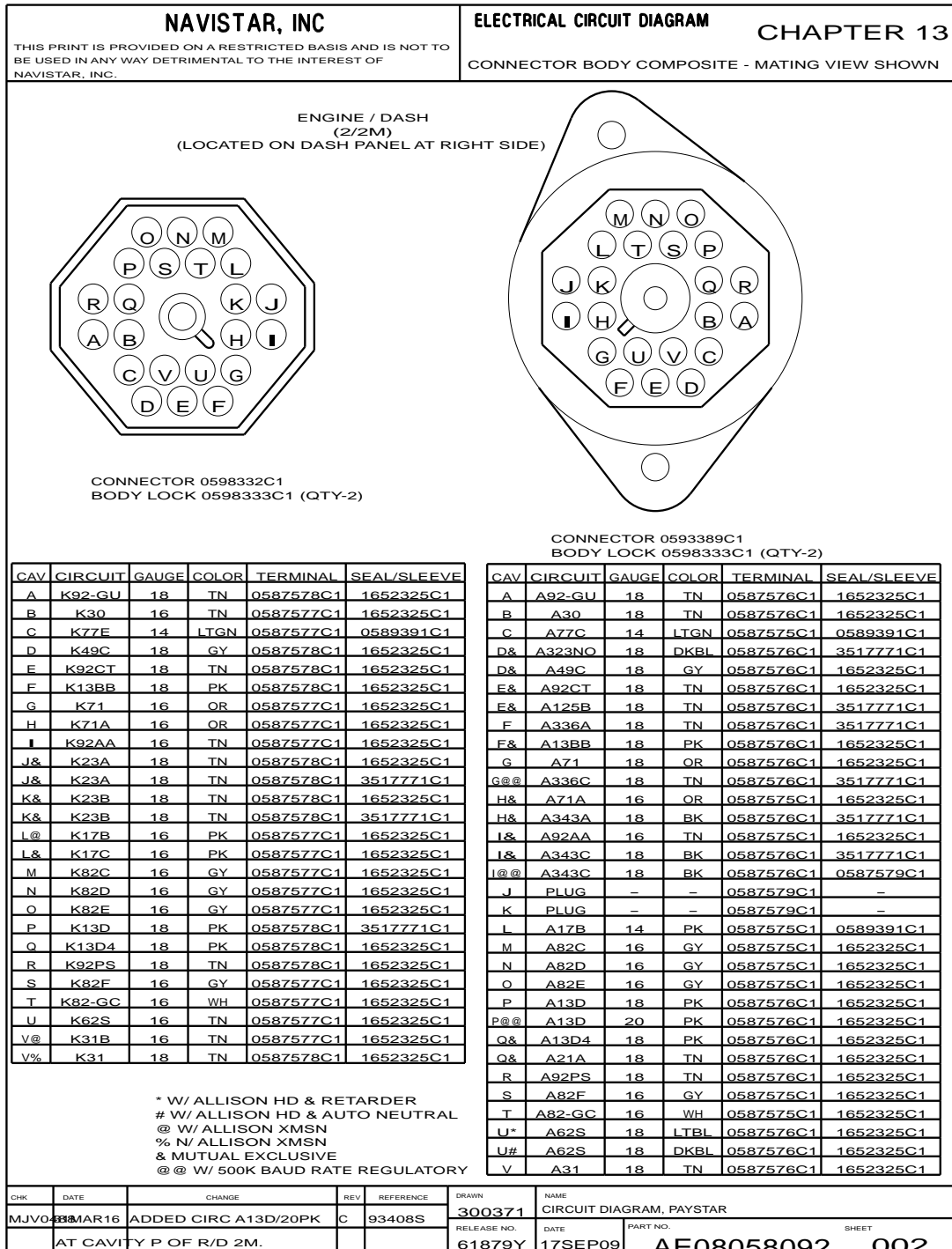


Figure 189 Connector Composites (2 / 2M)

13.3. CONNECTOR COMPOSITES (2), P. 2A

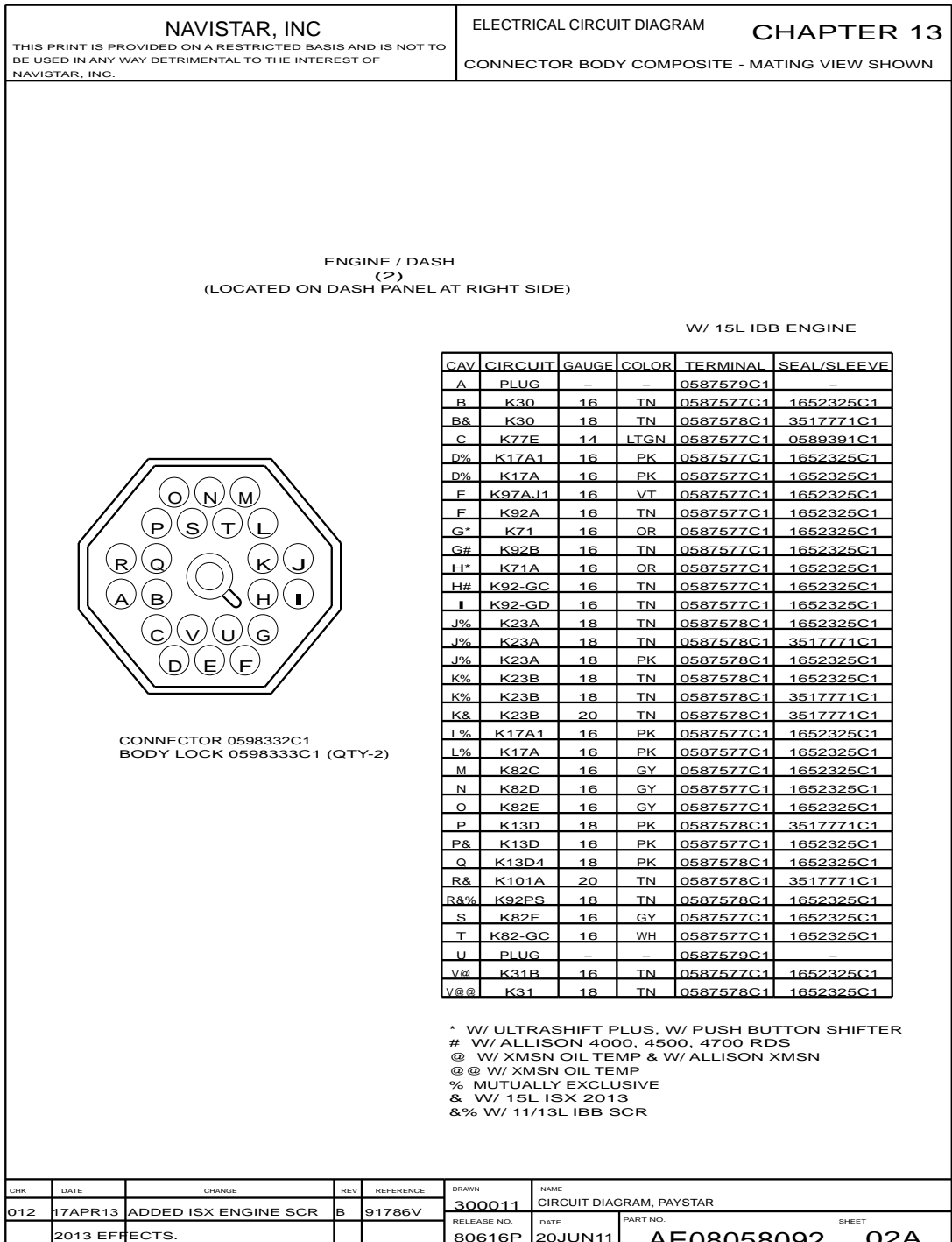


Figure 190 Connector Composites (2)



13.4. CONNECTOR BODY COMPOSITE (2), P. 2B

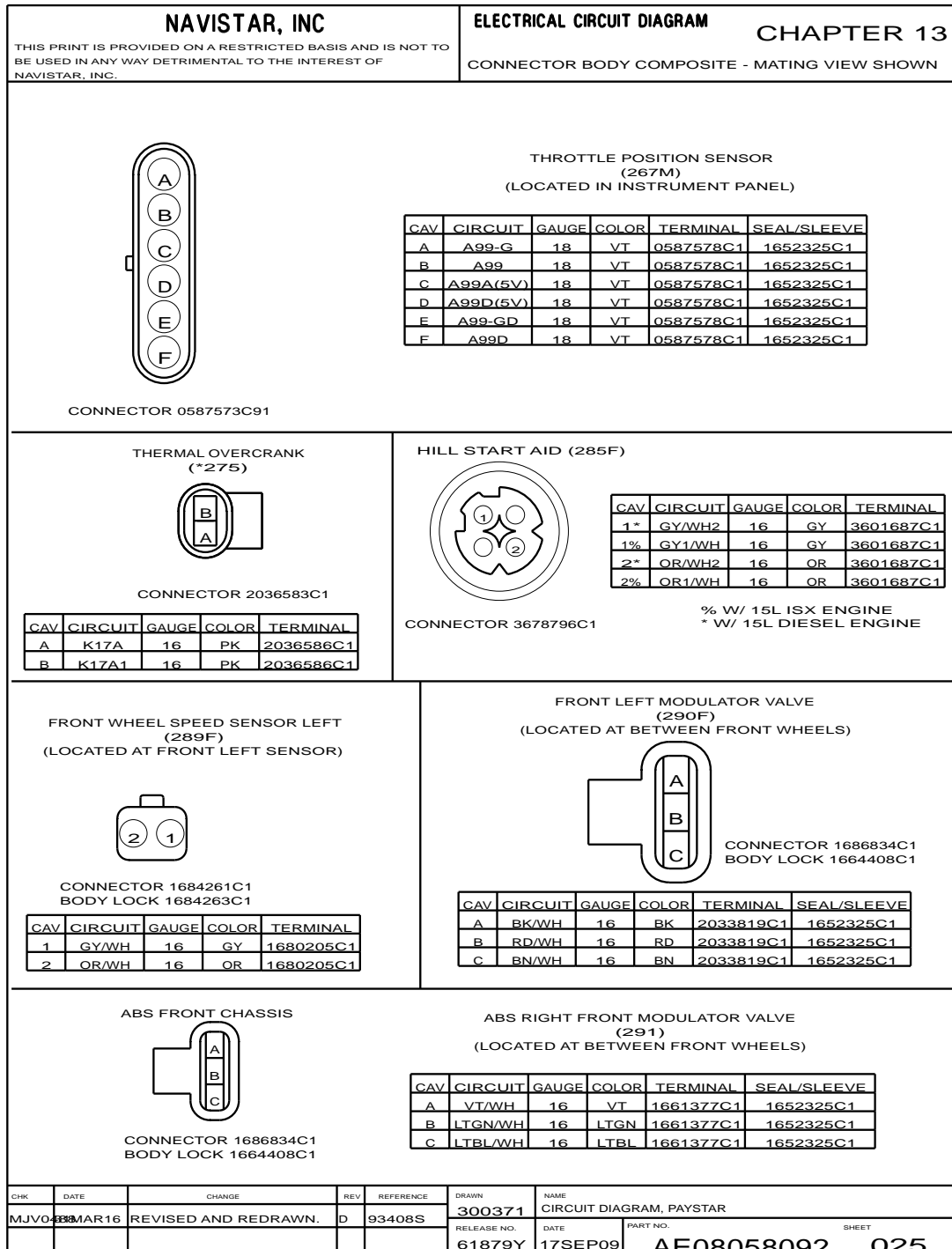


Figure 191 Connector Composites (2)

13.5. CONNECTOR COMPOSITES (3F / 3M), P. 3

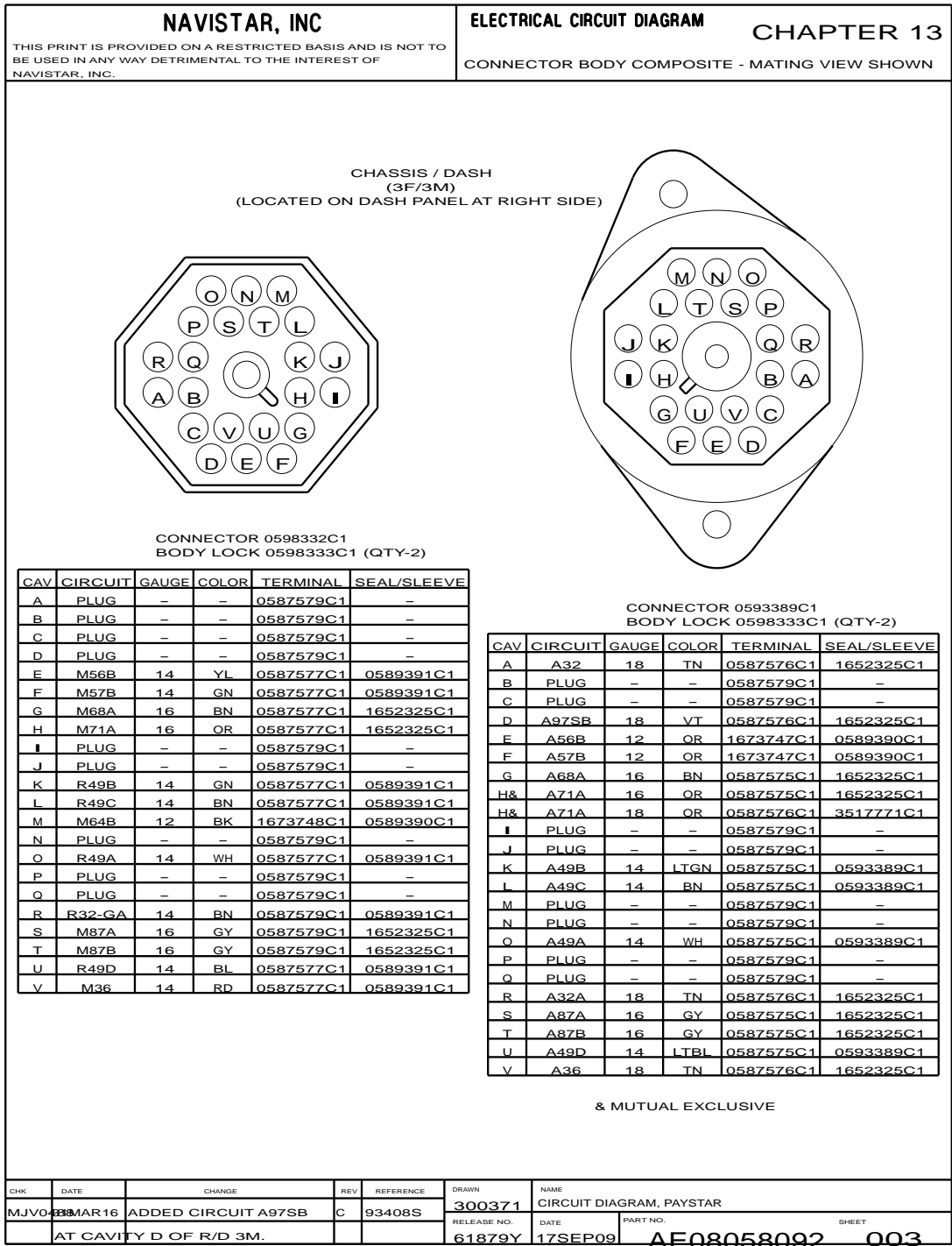


Figure 192 Connector Composites (3F / 3M)

13.6. CONNECTOR COMPOSITES (4M / 5 / 9 / 15M), P. 4

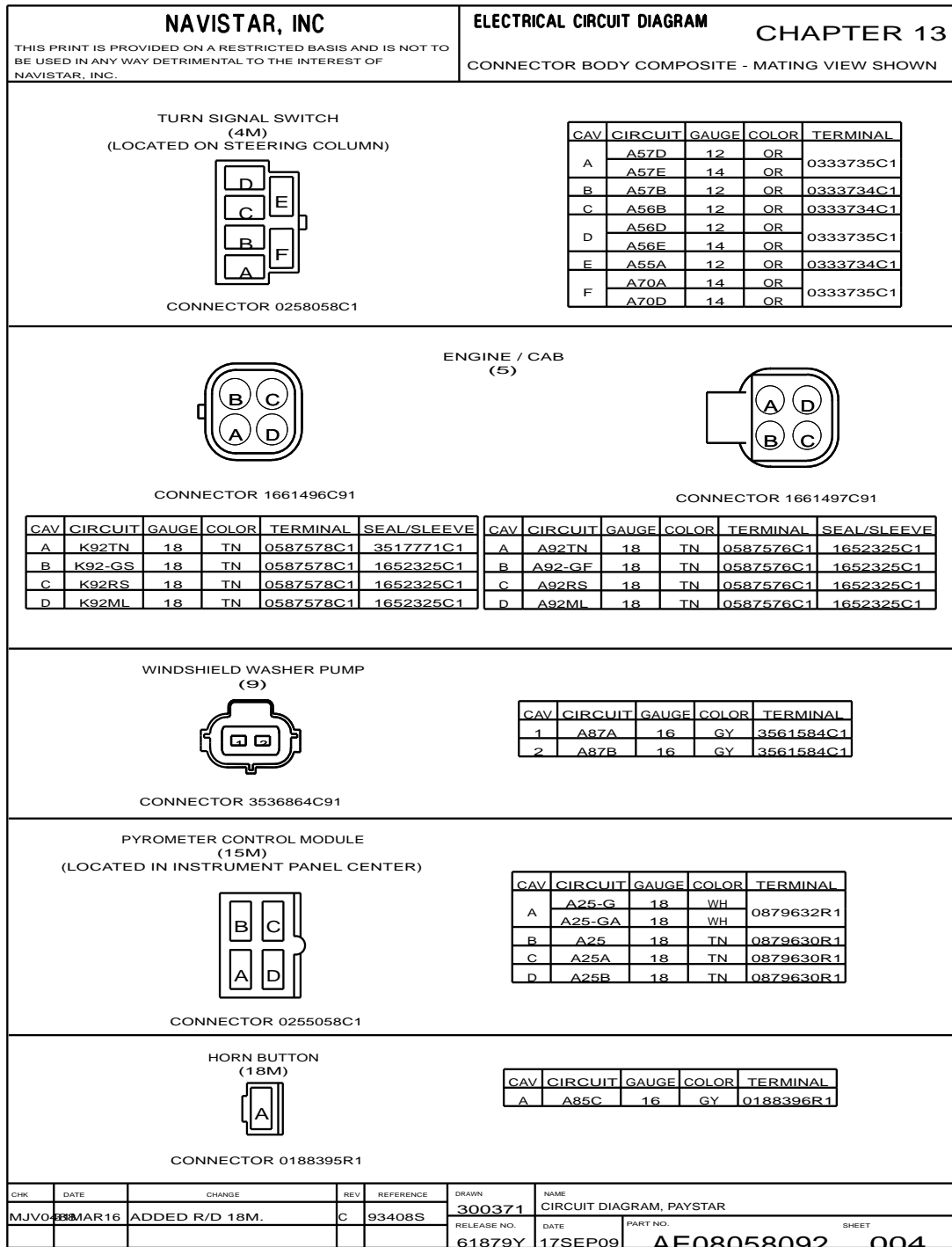


Figure 193 Connector Composites (4M / 5 / 9 / 15M)

13.7. CONNECTOR COMPOSITES (20 / 40M / 41M / 43M / 65 / 65F), P. 5

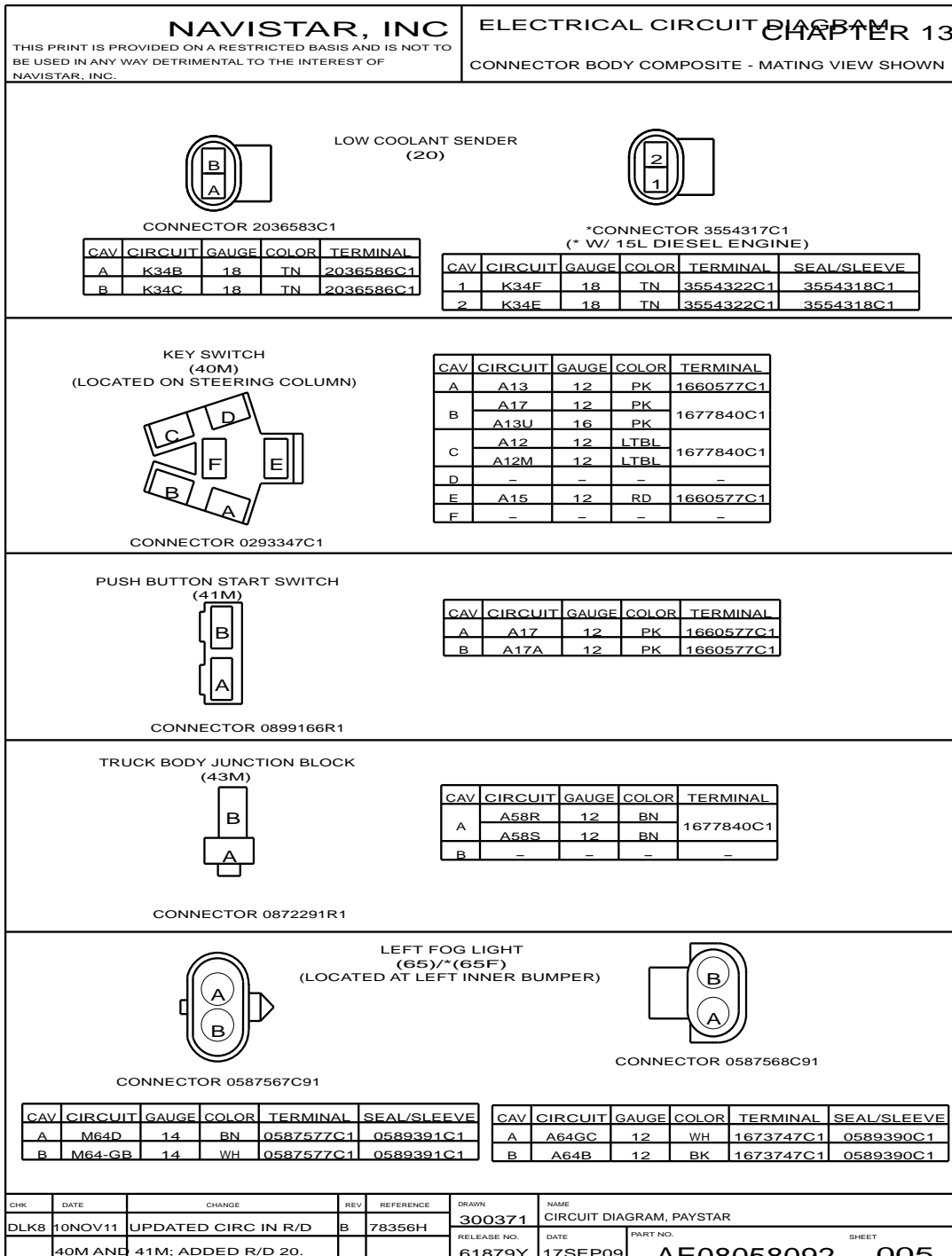


Figure 194 Connector Composites (20 / 40M / 41M / 43M / 65 / 65F)

13.8. CONNECTOR COMPOSITES (66F / 71 / 72 / 76M), P. 6

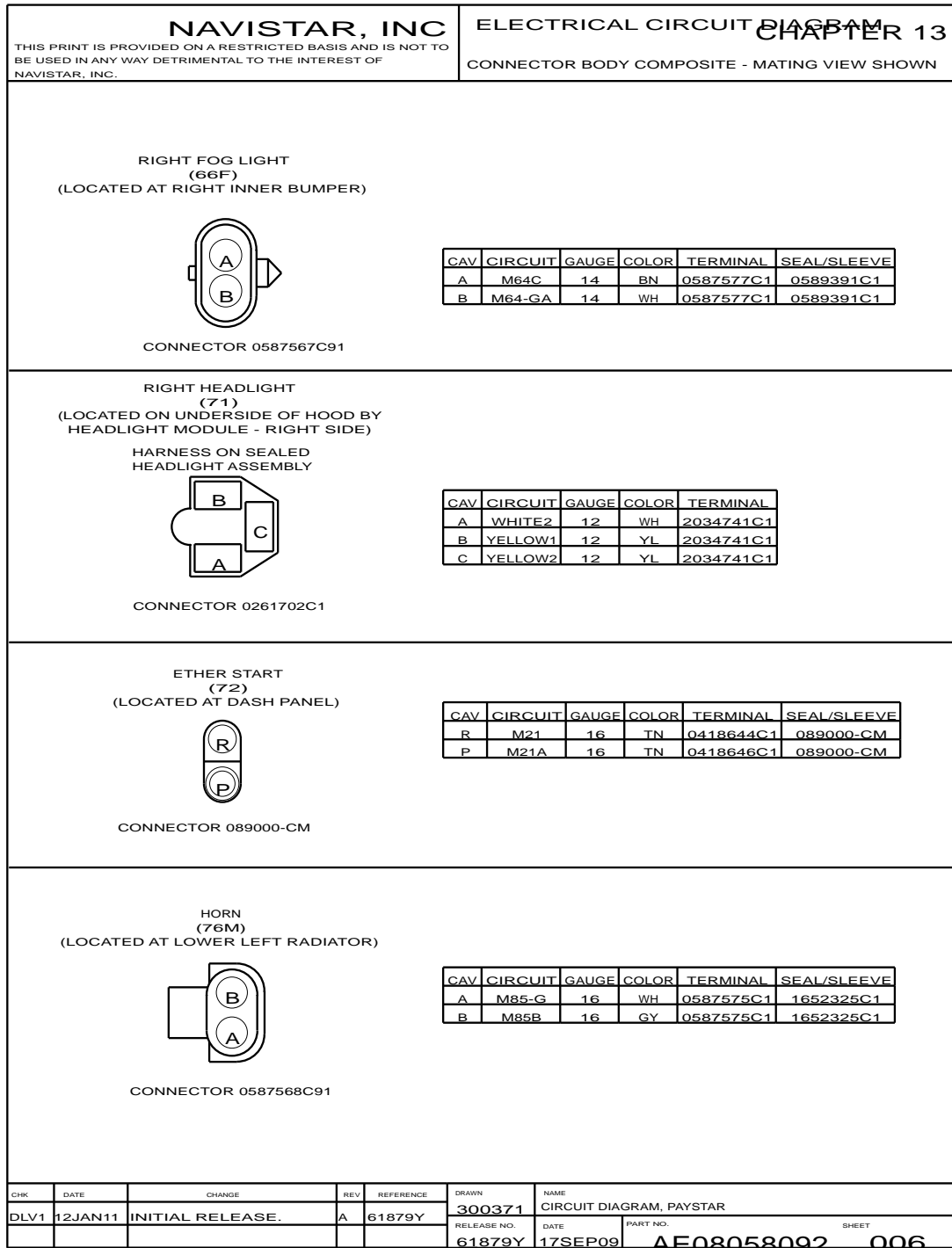


Figure 195 Connector Composites (66F / 71 / 72 / 76M)

13.9. CONNECTOR COMPOSITES (77 / 82 / 83F / 90M / 100 / 100A), P. 7

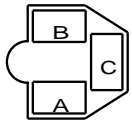
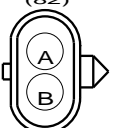
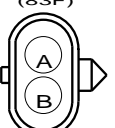

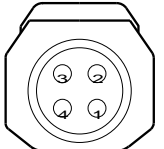

<b>NAVISTAR, INC</b>		<b>ELECTRICAL CIRCUIT DIAGRAM</b>		<b>CHAPTER 13</b>																										
THIS PRINT IS PROVIDED ON A RESTRICTED BASIS AND IS NOT TO BE USED IN ANY WAY DETRIMENTAL TO THE INTEREST OF NAVISTAR, INC.		CONNECTOR BODY COMPOSITE - MATING VIEW SHOWN																												
HARNESS ON SEALED HEADLIGHT ASSEMBLY  CONNECTOR 0261702C1		LEFT HEADLIGHT (W/ 9200, 9400 ONLY) (77) (LOCATED ON UNDERSIDE OF HOOD BY HEADLIGHT MODULE-LEFTSIDE)																												
		<table border="1" style="width:100%; border-collapse: collapse; font-size: x-small;"> <thead> <tr> <th>CAV</th> <th>CIRCUIT</th> <th>GAUGE</th> <th>COLOR</th> <th>TERMINAL</th> </tr> </thead> <tbody> <tr> <td>A</td> <td>WHITE2</td> <td>12</td> <td>WH</td> <td>2034741C1</td> </tr> <tr> <td>B</td> <td>YELLOW2</td> <td>12</td> <td>YL</td> <td>2034741C1</td> </tr> <tr> <td>C</td> <td>YELLOW2</td> <td>12</td> <td>YL</td> <td>2034741C1</td> </tr> </tbody> </table>				CAV	CIRCUIT	GAUGE	COLOR	TERMINAL	A	WHITE2	12	WH	2034741C1	B	YELLOW2	12	YL	2034741C1	C	YELLOW2	12	YL	2034741C1					
CAV	CIRCUIT	GAUGE	COLOR	TERMINAL																										
A	WHITE2	12	WH	2034741C1																										
B	YELLOW2	12	YL	2034741C1																										
C	YELLOW2	12	YL	2034741C1																										
RIGHT TURN, MARKER & PARK LIGHT (82)  CONNECTOR 0587567C91		<table border="1" style="width:100%; border-collapse: collapse; font-size: x-small;"> <thead> <tr> <th>CAV</th> <th>CIRCUIT</th> <th>GAUGE</th> <th>COLOR</th> <th>TERMINAL</th> <th>SEAL/SLEEVE</th> </tr> </thead> <tbody> <tr> <td>A</td> <td>M58U</td> <td>16</td> <td>BN</td> <td>0587577C1</td> <td>1652325C1</td> </tr> <tr> <td>B#</td> <td>M57</td> <td>16</td> <td>OR</td> <td>0587577C1</td> <td>1652325C1</td> </tr> <tr> <td>B*</td> <td>M57C</td> <td>16</td> <td>OR</td> <td>0587577C1</td> <td>1652325C1</td> </tr> </tbody> </table> <p style="font-size: x-small; text-align: center;">* W/ AUXILIARY LIGHTS # N/ AUXILIARY LIGHTS</p>				CAV	CIRCUIT	GAUGE	COLOR	TERMINAL	SEAL/SLEEVE	A	M58U	16	BN	0587577C1	1652325C1	B#	M57	16	OR	0587577C1	1652325C1	B*	M57C	16	OR	0587577C1	1652325C1	
CAV	CIRCUIT	GAUGE	COLOR	TERMINAL	SEAL/SLEEVE																									
A	M58U	16	BN	0587577C1	1652325C1																									
B#	M57	16	OR	0587577C1	1652325C1																									
B*	M57C	16	OR	0587577C1	1652325C1																									
LEFT TURN, MARKER & PARK LIGHT (83F)  CONNECTOR 0587567C91		<table border="1" style="width:100%; border-collapse: collapse; font-size: x-small;"> <thead> <tr> <th>CAV</th> <th>CIRCUIT</th> <th>GAUGE</th> <th>COLOR</th> <th>TERMINAL</th> <th>SEAL/SLEEVE</th> </tr> </thead> <tbody> <tr> <td>A</td> <td>M58T</td> <td>16</td> <td>BN</td> <td>0587577C1</td> <td>1652325C1</td> </tr> <tr> <td>B#</td> <td>M56</td> <td>16</td> <td>OR</td> <td>0587577C1</td> <td>1652325C1</td> </tr> <tr> <td>B*</td> <td>M56C</td> <td>16</td> <td>OR</td> <td>0587577C1</td> <td>1652325C1</td> </tr> </tbody> </table> <p style="font-size: x-small; text-align: center;">* W/ AUXILIARY LIGHTS # N/ AUXILIARY LIGHTS</p>				CAV	CIRCUIT	GAUGE	COLOR	TERMINAL	SEAL/SLEEVE	A	M58T	16	BN	0587577C1	1652325C1	B#	M56	16	OR	0587577C1	1652325C1	B*	M56C	16	OR	0587577C1	1652325C1	
CAV	CIRCUIT	GAUGE	COLOR	TERMINAL	SEAL/SLEEVE																									
A	M58T	16	BN	0587577C1	1652325C1																									
B#	M56	16	OR	0587577C1	1652325C1																									
B*	M56C	16	OR	0587577C1	1652325C1																									
CIGAR LIGHTER LIGHT (90M)  CONNECTOR 0188395R1		W/ 500K BAUD RATE REGULATORY <table border="1" style="width:100%; border-collapse: collapse; font-size: x-small;"> <thead> <tr> <th>CAV</th> <th>CIRCUIT</th> <th>GAUGE</th> <th>COLOR</th> <th>TERMINAL</th> </tr> </thead> <tbody> <tr> <td>A</td> <td>62AA</td> <td>16</td> <td>DKBL</td> <td>0188396R1</td> </tr> </tbody> </table>				CAV	CIRCUIT	GAUGE	COLOR	TERMINAL	A	62AA	16	DKBL	0188396R1															
CAV	CIRCUIT	GAUGE	COLOR	TERMINAL																										
A	62AA	16	DKBL	0188396R1																										
BACKBONE J1939 (ENGINE CONNECTION) (100A)  CONNECTOR 3537127C1		W/ BENDIX ABS <table border="1" style="width:100%; border-collapse: collapse; font-size: x-small;"> <thead> <tr> <th>CAV</th> <th>CIRCUIT</th> <th>GAUGE</th> <th>COLOR</th> <th>TERMINAL</th> </tr> </thead> <tbody> <tr> <td>1</td> <td>YL2(+)</td> <td>18</td> <td>YL</td> <td>3537131C1</td> </tr> <tr> <td>2</td> <td>PLUG</td> <td>-</td> <td>-</td> <td>3537132C1</td> </tr> <tr> <td>3</td> <td>GN2(-)</td> <td>14</td> <td>LTGN</td> <td>1661231C1</td> </tr> <tr> <td>4</td> <td>PLUG</td> <td>-</td> <td>-</td> <td>3537131C1</td> </tr> </tbody> </table>				CAV	CIRCUIT	GAUGE	COLOR	TERMINAL	1	YL2(+)	18	YL	3537131C1	2	PLUG	-	-	3537132C1	3	GN2(-)	14	LTGN	1661231C1	4	PLUG	-	-	3537131C1
CAV	CIRCUIT	GAUGE	COLOR	TERMINAL																										
1	YL2(+)	18	YL	3537131C1																										
2	PLUG	-	-	3537132C1																										
3	GN2(-)	14	LTGN	1661231C1																										
4	PLUG	-	-	3537131C1																										
J1939 BACK BONE (100)  CONNECTOR 1667741C1 BODY LOCK 1667771C1		<table border="1" style="width:100%; border-collapse: collapse; font-size: x-small;"> <thead> <tr> <th>CAV</th> <th>CIRCUIT</th> <th>GAUGE</th> <th>COLOR</th> <th>TERMINAL</th> <th>SEAL/SLEEVE</th> </tr> </thead> <tbody> <tr> <td>A</td> <td>YL(+)</td> <td>18</td> <td>YL</td> <td>1661875C1</td> <td>3568570C1</td> </tr> <tr> <td>B</td> <td>PLUG</td> <td>-</td> <td>-</td> <td>2025431C1</td> <td>-</td> </tr> <tr> <td>C</td> <td>GN(-)</td> <td>18</td> <td>GN</td> <td>1661875C1</td> <td>3568570C1</td> </tr> </tbody> </table>				CAV	CIRCUIT	GAUGE	COLOR	TERMINAL	SEAL/SLEEVE	A	YL(+)	18	YL	1661875C1	3568570C1	B	PLUG	-	-	2025431C1	-	C	GN(-)	18	GN	1661875C1	3568570C1	
CAV	CIRCUIT	GAUGE	COLOR	TERMINAL	SEAL/SLEEVE																									
A	YL(+)	18	YL	1661875C1	3568570C1																									
B	PLUG	-	-	2025431C1	-																									
C	GN(-)	18	GN	1661875C1	3568570C1																									
CHK	DATE	CHANGE	REV	REFERENCE	DRAWN	NAME																								
0488	09SEP15	ADDED R/D 100 AND	C	93248U	300371	CIRCUIT DIAGRAM, PAYSTAR																								
REMOVED	R/D 100R.				RELEASE NO.	DATE																								
					61879Y	17SEP09																								
					PART NO.	SHEET																								
					AE08058092	007																								

Figure 196 Connector Composites (77 / 82 / 83F / 90M / 100 / 100A)

13.10. CONNECTOR COMPOSITES (100), P. 8

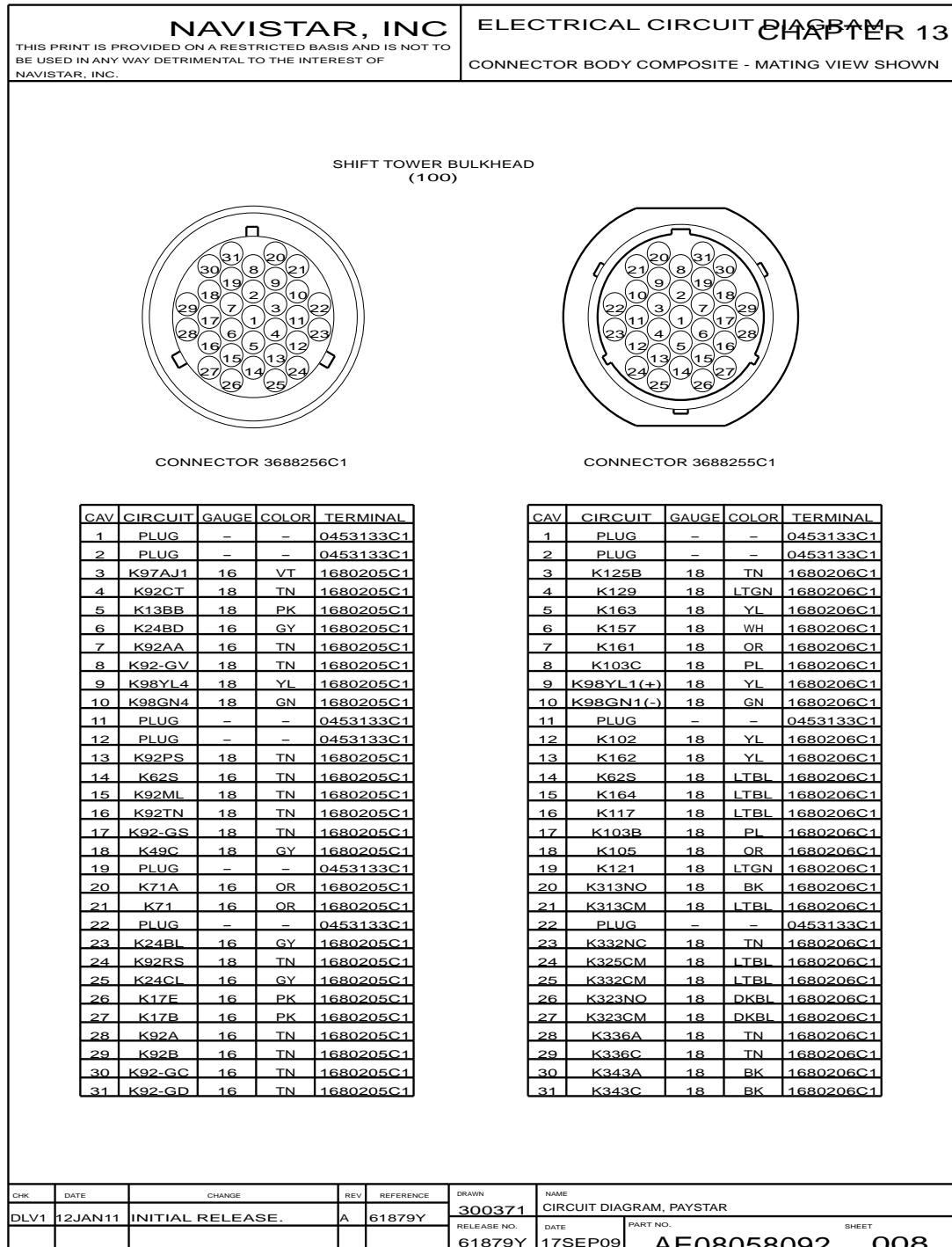


Figure 197 Connector Composites (100)

13.11. CONNECTOR COMPOSITES (100F / 101F / 102F / 100M3), P. 8A

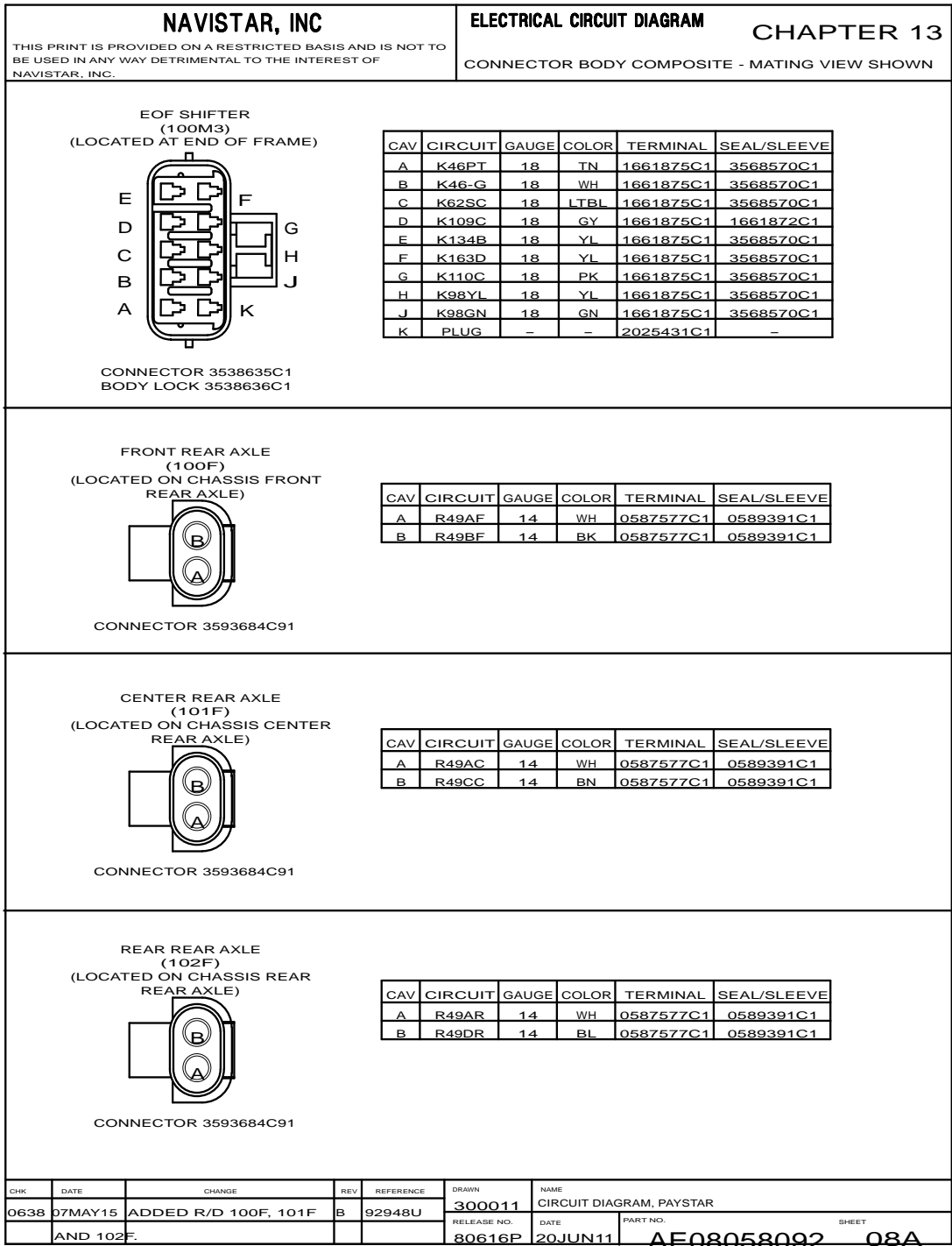


Figure 198 Connector Composites (100F / 101F / 102F / 100M3)



13.12. CONNECTOR COMPOSITES (105), P. 9

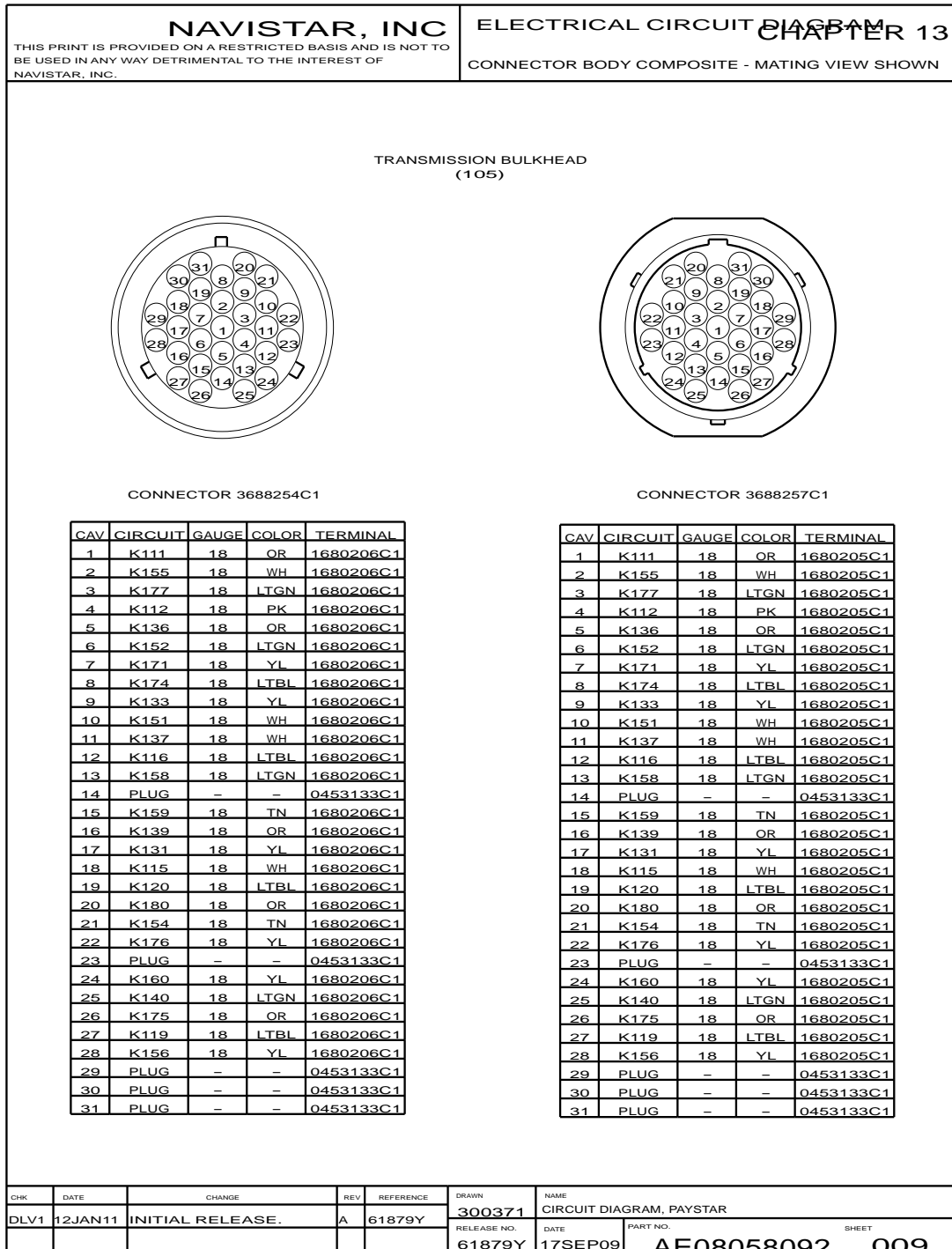


Figure 199 Connector Composites (105)

13.13. CONNECTOR COMPOSITES (105F), P. 10

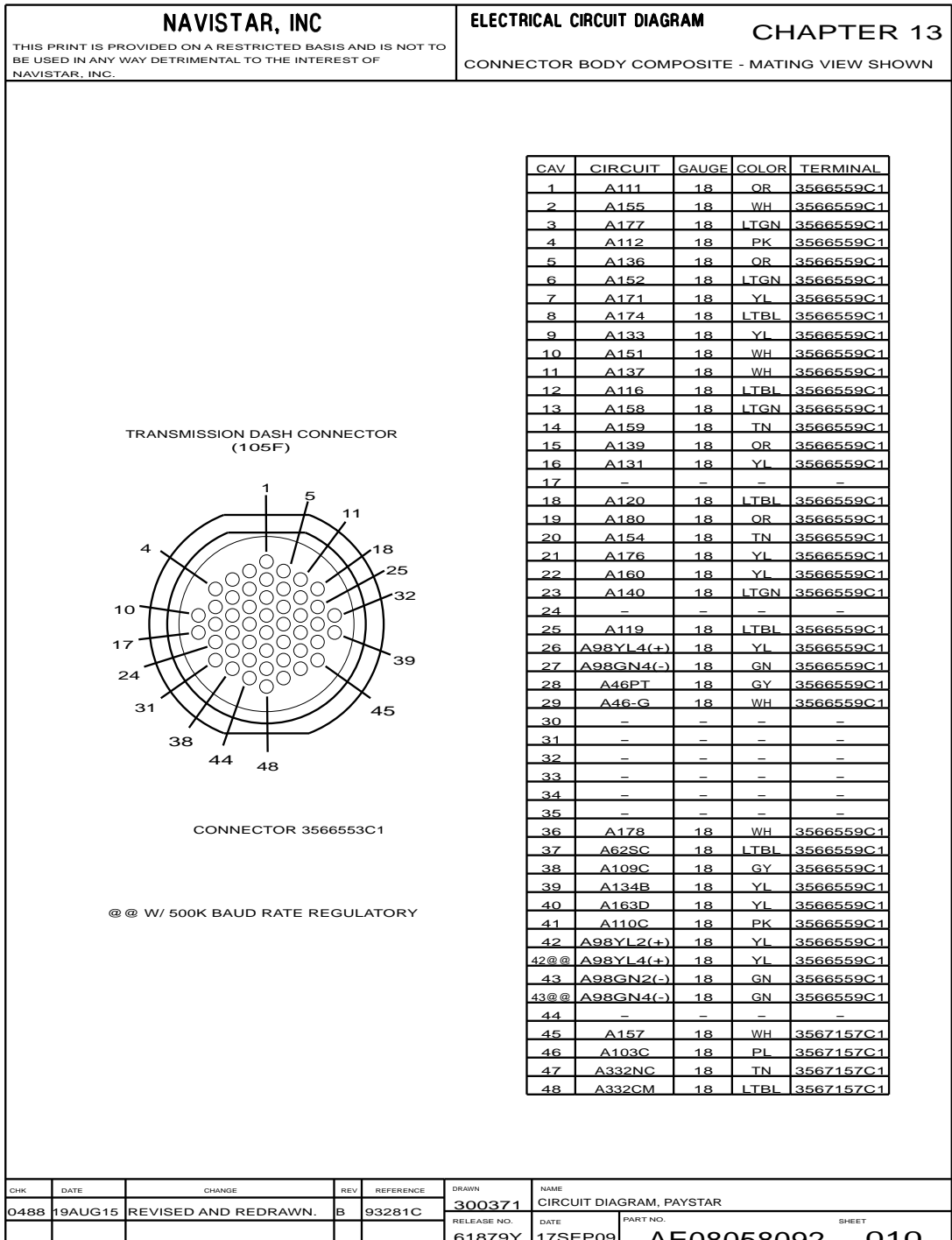


Figure 200 Connector Composites (105F)

13.14. CONNECTOR COMPOSITES (105M), P. 10A

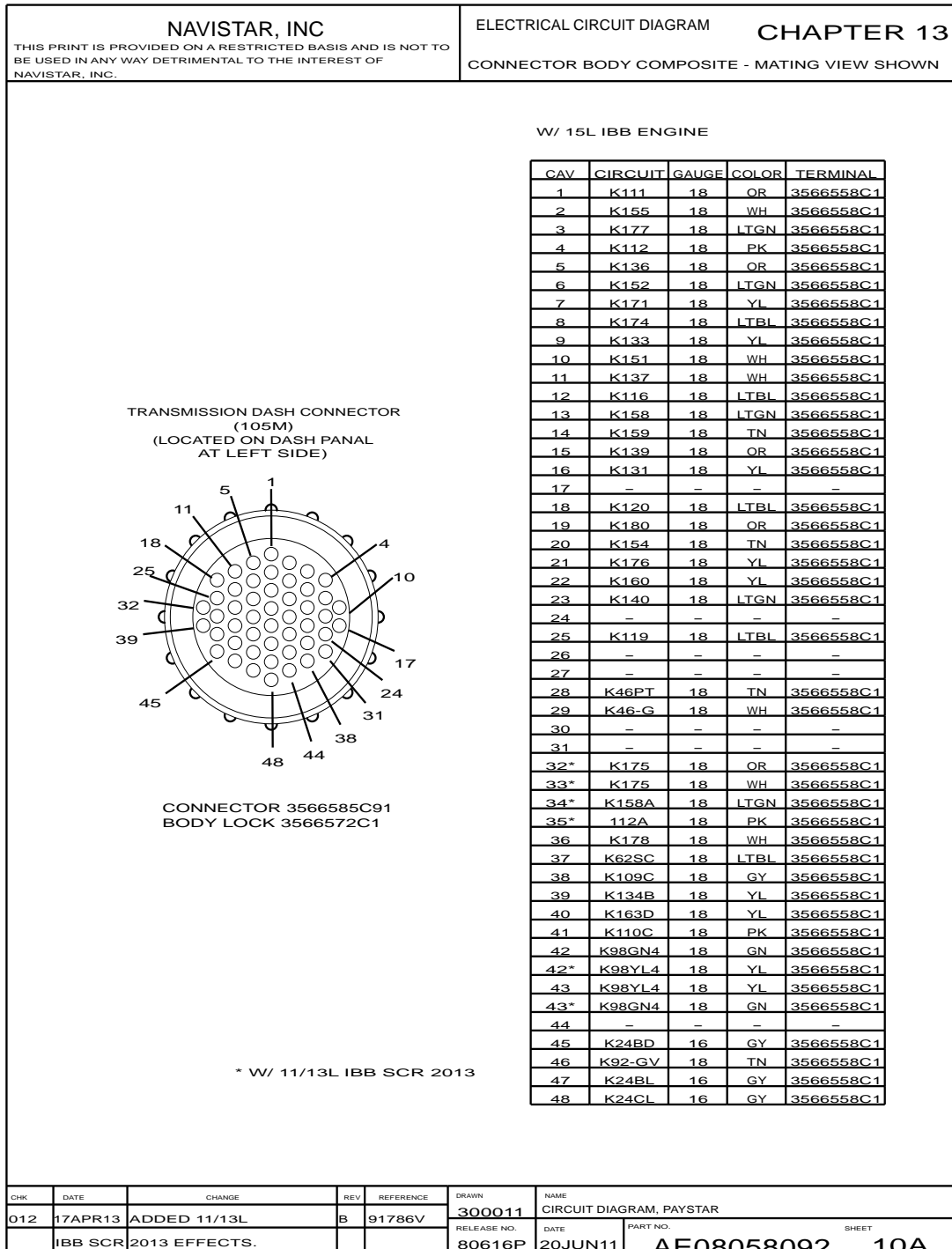


Figure 201 Connector Composites (105M)

13.15. CONNECTOR COMPOSITES (106F / 107M / 108F), P. 11

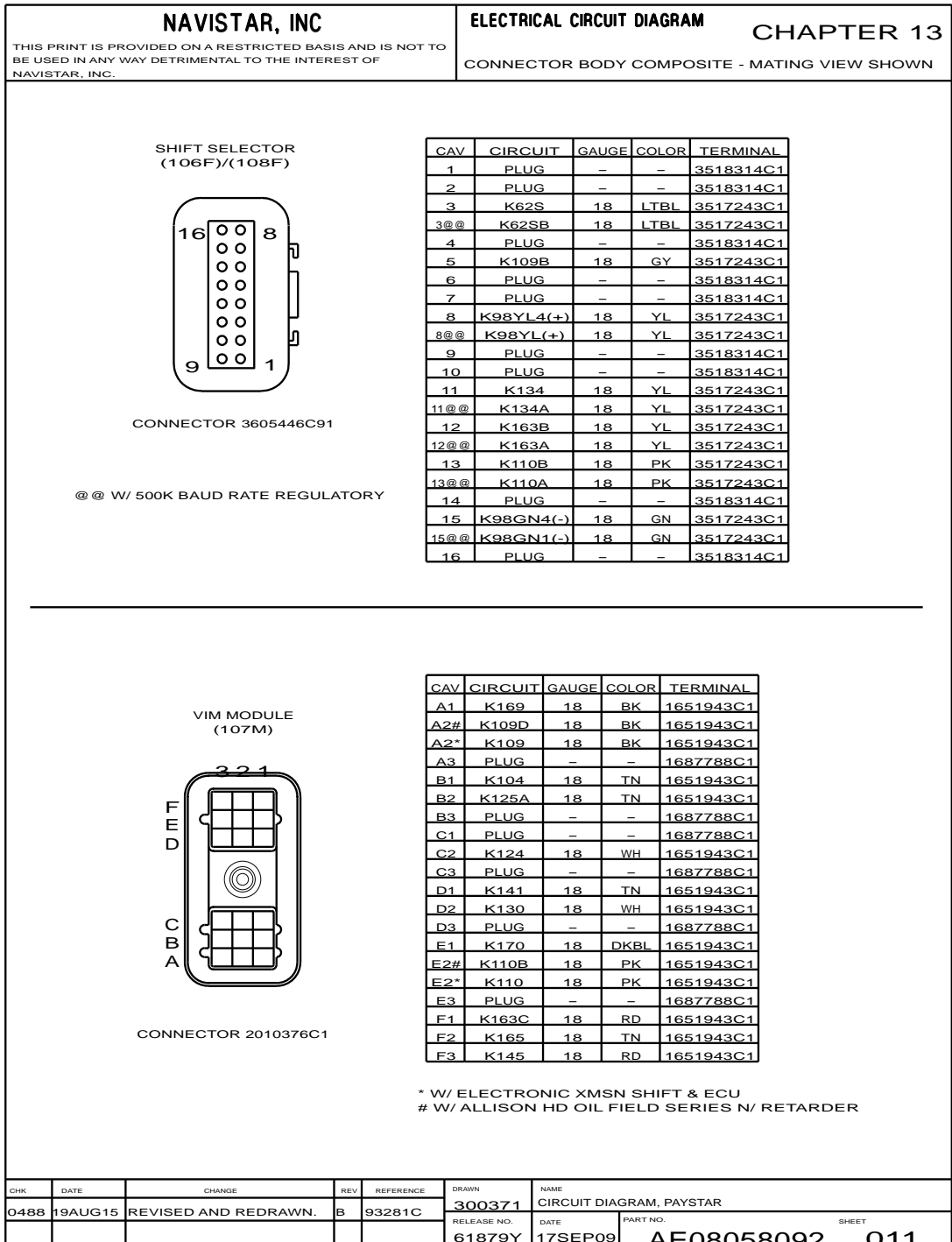


Figure 202 Connector Composites (106F / 107M / 108F)

13.16. CONNECTOR COMPOSITES (108M), P. 12

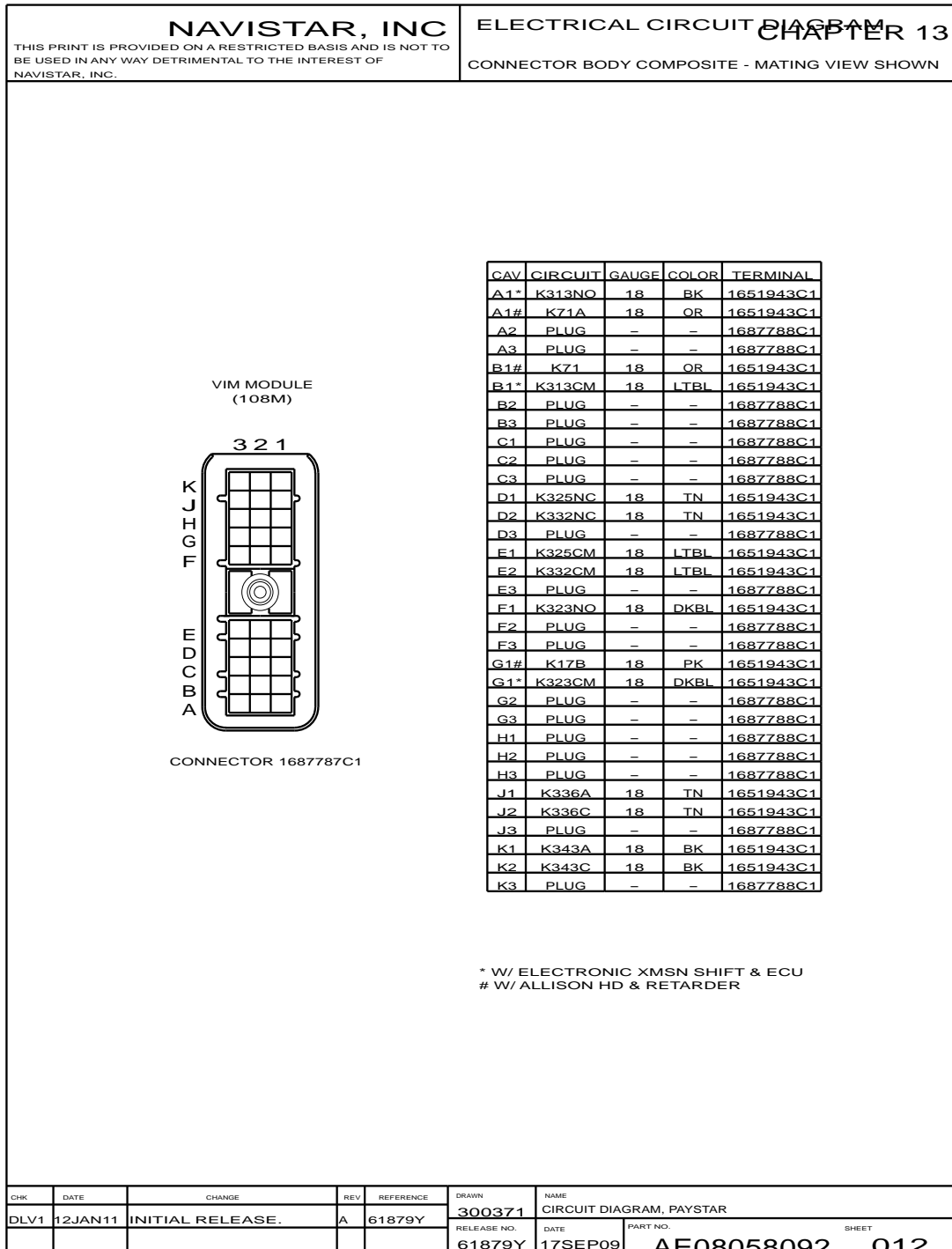


Figure 203 Connector Composites (108M)

13.17. CONNECTOR COMPOSITES (112 / 113 / 115), P. 13

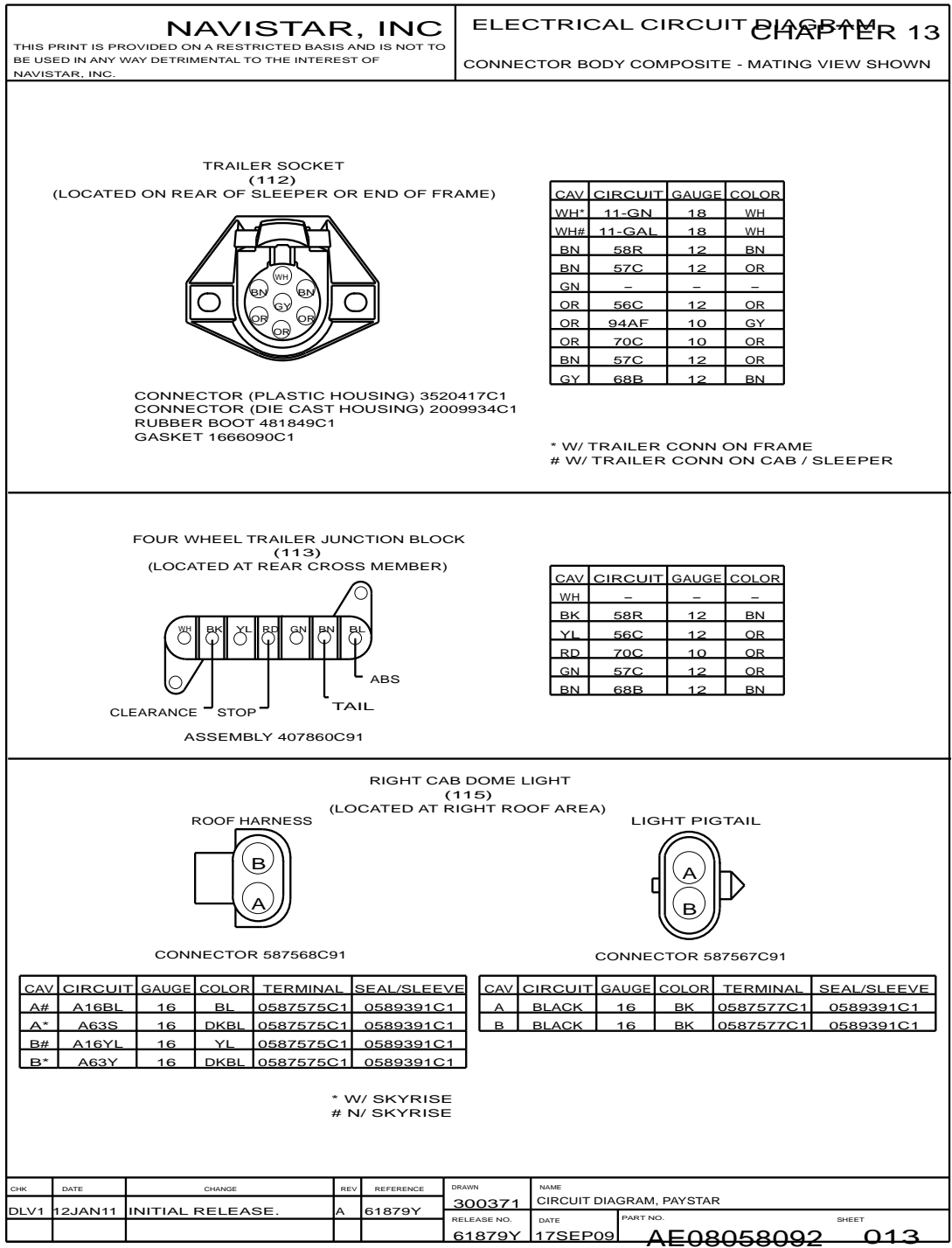


Figure 204 Connector Composites (112 / 113 / 115)

13.18. CONNECTOR COMPOSITES (127A / 128 / 137M / 141F), P. 14

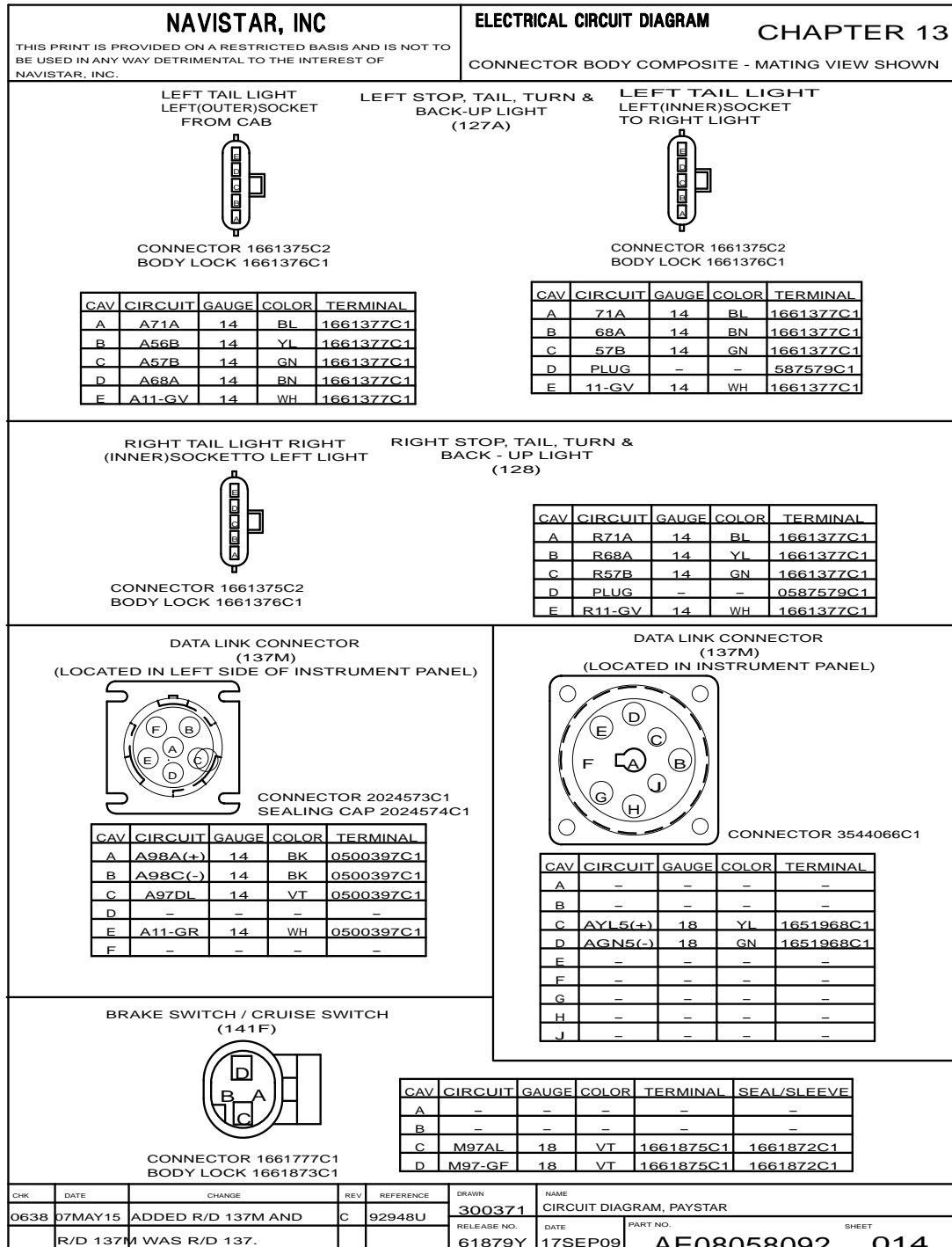


Figure 205 Connector Composites (127A / 128 / 137M / 141F)

13.19. CONNECTOR COMPOSITES (141F / 142M / 143M / 144M), P. 15

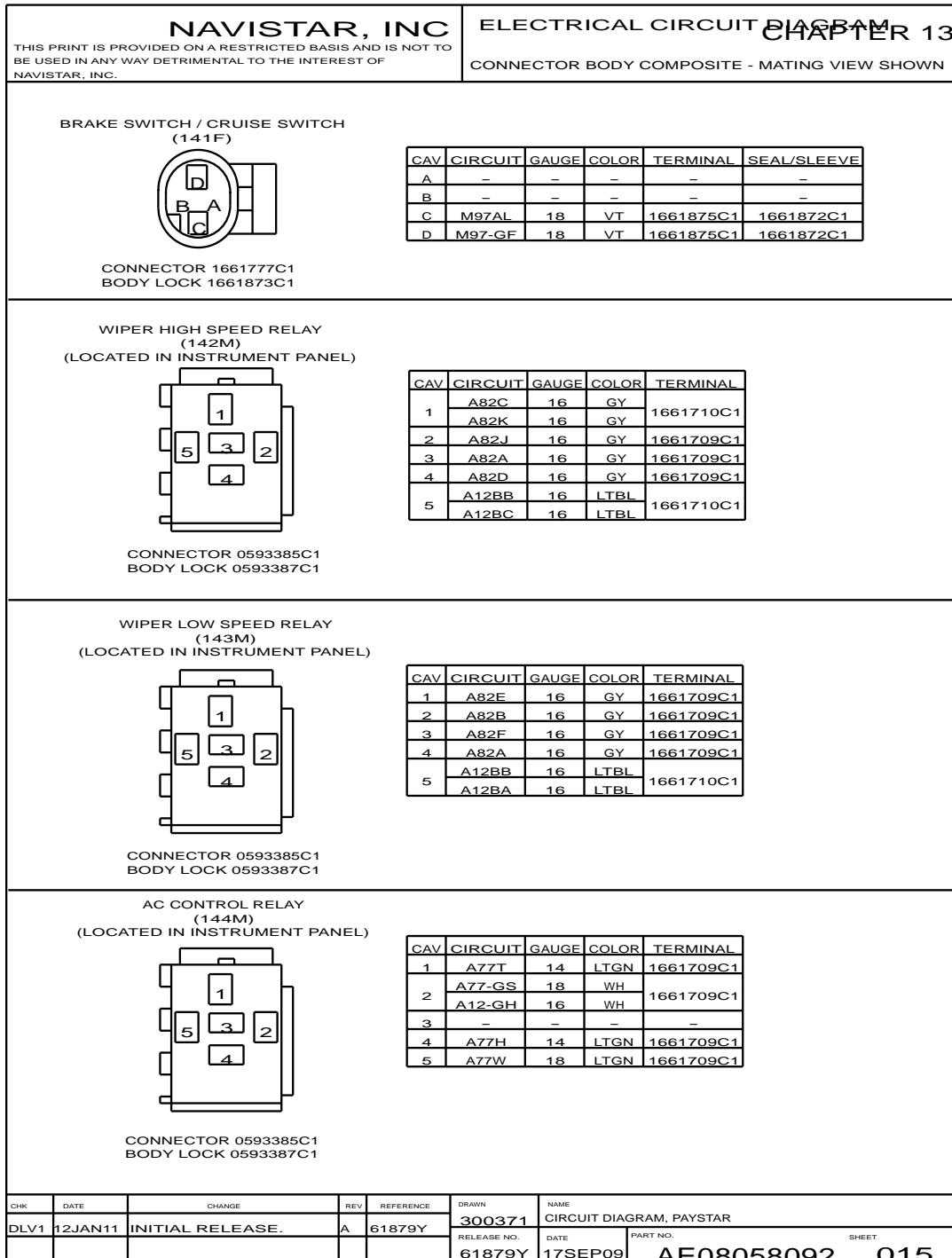


Figure 206 Connector Composites (141F / 142M / 143M / 144M)



13.20. CONNECTOR COMPOSITES (145M / 146M / 147M), P. 16

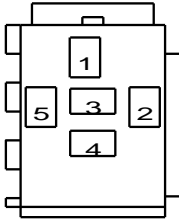
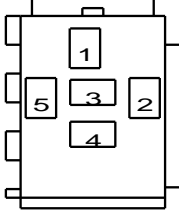
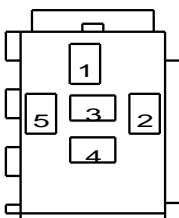
<p><b>NAVISTAR, INC</b>  <small>THIS PRINT IS PROVIDED ON A RESTRICTED BASIS AND IS NOT TO BE USED IN ANY WAY DETRIMENTAL TO THE INTEREST OF NAVISTAR, INC.</small></p>				<p><b>ELECTRICAL CIRCUIT DIAGRAM</b>  <b>CHAPTER 13</b>                  CONNECTOR BODY COMPOSITE - MATING VIEW SHOWN</p>																																					
<p><b>ACCESSORY FEED RELAY (145M)</b> (LOCATED IN INSTRUMENT PANEL)</p>  <table border="1" style="margin-left: auto; margin-right: auto; border-collapse: collapse;"> <thead> <tr> <th>CAV</th> <th>CIRCUIT</th> <th>GAUGE</th> <th>COLOR</th> <th>TERMINAL</th> </tr> </thead> <tbody> <tr> <td>1</td> <td>A14BJ</td> <td>10</td> <td>RD</td> <td>1661710C1</td> </tr> <tr> <td>2</td> <td>A12-GH</td> <td>16</td> <td>WH</td> <td>1661709C1</td> </tr> <tr> <td>3</td> <td>-</td> <td>-</td> <td>-</td> <td>-</td> </tr> <tr> <td>4</td> <td>A12AD</td> <td>10</td> <td>LTBL</td> <td>1661710C1</td> </tr> <tr> <td>5</td> <td>A12AC</td> <td>12</td> <td>LTBL</td> <td>1661710C1</td> </tr> </tbody> </table> <p style="text-align: center; margin-top: 10px;">CONNECTOR 0593385C1 BODY LOCK 0593387C1</p>						CAV	CIRCUIT	GAUGE	COLOR	TERMINAL	1	A14BJ	10	RD	1661710C1	2	A12-GH	16	WH	1661709C1	3	-	-	-	-	4	A12AD	10	LTBL	1661710C1	5	A12AC	12	LTBL	1661710C1						
CAV	CIRCUIT	GAUGE	COLOR	TERMINAL																																					
1	A14BJ	10	RD	1661710C1																																					
2	A12-GH	16	WH	1661709C1																																					
3	-	-	-	-																																					
4	A12AD	10	LTBL	1661710C1																																					
5	A12AC	12	LTBL	1661710C1																																					
<p><b>AIR DRYER RELAY (146M)</b> (LOCATED IN INSTRUMENT PANEL)</p>  <table border="1" style="margin-left: auto; margin-right: auto; border-collapse: collapse;"> <thead> <tr> <th>CAV</th> <th>CIRCUIT</th> <th>GAUGE</th> <th>COLOR</th> <th>TERMINAL</th> </tr> </thead> <tbody> <tr> <td>1</td> <td>A39A</td> <td>16</td> <td>GY</td> <td>1661709C1</td> </tr> <tr> <td>2</td> <td>A13-GAD</td> <td>18</td> <td>WH</td> <td>1659673C1</td> </tr> <tr> <td>3</td> <td>-</td> <td>-</td> <td>-</td> <td>-</td> </tr> <tr> <td>4</td> <td>A39B</td> <td>16</td> <td>GY</td> <td>1661709C1</td> </tr> <tr> <td>5</td> <td>A13AH</td> <td>14</td> <td>PK</td> <td>1661709C1</td> </tr> </tbody> </table> <p style="text-align: center; margin-top: 10px;">CONNECTOR 0593385C1 BODY LOCK 0593387C1</p>						CAV	CIRCUIT	GAUGE	COLOR	TERMINAL	1	A39A	16	GY	1661709C1	2	A13-GAD	18	WH	1659673C1	3	-	-	-	-	4	A39B	16	GY	1661709C1	5	A13AH	14	PK	1661709C1						
CAV	CIRCUIT	GAUGE	COLOR	TERMINAL																																					
1	A39A	16	GY	1661709C1																																					
2	A13-GAD	18	WH	1659673C1																																					
3	-	-	-	-																																					
4	A39B	16	GY	1661709C1																																					
5	A13AH	14	PK	1661709C1																																					
<p><b>HEADLIGHT DIMMER RELAY (147M)</b> (LOCATED IN INSTRUMENT PANEL)</p>  <table border="1" style="margin-left: auto; margin-right: auto; border-collapse: collapse;"> <thead> <tr> <th>CAV</th> <th>CIRCUIT</th> <th>GAUGE</th> <th>COLOR</th> <th>TERMINAL</th> </tr> </thead> <tbody> <tr> <td>1</td> <td>A51A</td> <td>14</td> <td>YL</td> <td>1661709C1</td> </tr> <tr> <td>2</td> <td>A52N</td> <td>16</td> <td>YL</td> <td>1661709C1</td> </tr> <tr> <td rowspan="2">3</td> <td>A53B</td> <td>14</td> <td>YL</td> <td rowspan="2">1661710C1</td> </tr> <tr> <td>A64C</td> <td>14</td> <td>YL</td> </tr> <tr> <td rowspan="2">4</td> <td>A52B</td> <td>14</td> <td>YL</td> <td rowspan="2">1661710C1</td> </tr> <tr> <td>A52F</td> <td>12</td> <td>YL</td> </tr> <tr> <td>5</td> <td>A52M</td> <td>16</td> <td>YL</td> <td>1661709C1</td> </tr> </tbody> </table> <p style="text-align: center; margin-top: 10px;">CONNECTOR 0593385C1 BODY LOCK 0593387C1</p>						CAV	CIRCUIT	GAUGE	COLOR	TERMINAL	1	A51A	14	YL	1661709C1	2	A52N	16	YL	1661709C1	3	A53B	14	YL	1661710C1	A64C	14	YL	4	A52B	14	YL	1661710C1	A52F	12	YL	5	A52M	16	YL	1661709C1
CAV	CIRCUIT	GAUGE	COLOR	TERMINAL																																					
1	A51A	14	YL	1661709C1																																					
2	A52N	16	YL	1661709C1																																					
3	A53B	14	YL	1661710C1																																					
	A64C	14	YL																																						
4	A52B	14	YL	1661710C1																																					
	A52F	12	YL																																						
5	A52M	16	YL	1661709C1																																					
CHK	DATE	CHANGE	REV	REFERENCE	DRAWN																																				
DLV1	12JAN11	INITIAL RELEASE.	A	61879Y	300371																																				
					CIRCUIT DIAGRAM, PAYSTAR																																				
					RELEASE NO. DATE PART NO. SHEET																																				
					61879Y 17SEP09 AE08058092 016																																				

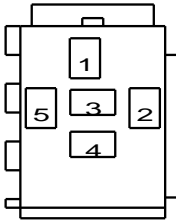
Figure 207 Connector Composites (145M / 146M / 147M)

13.21. CONNECTOR COMPOSITES (148M / 149M / 152M), P. 17

<b>NAVISTAR, INC</b>		<b>ELECTRICAL CIRCUIT DIAGRAM</b>		<b>CHAPTER 13</b>	
THIS PRINT IS PROVIDED ON A RESTRICTED BASIS AND IS NOT TO BE USED IN ANY WAY DETRIMENTAL TO THE INTEREST OF NAVISTAR, INC.		CONNECTOR BODY COMPOSITE - MATING VIEW SHOWN			

**ECM PARK BRAKE RELAY  
(148M)  
(LOCATED IN INSTRUMENT PANEL)**

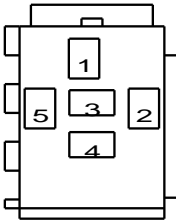


GAV	CIRCUIT	GAUGE	COLOR	TERMINAL
1	A44EB	18	PK	1661709C1
	A44EA	18	PK	1659673C1
2	A44EA	18	PK	1659673C1
3	-	-	-	-
4	A44EC	18	GY	1659673C1
5	A44-GE	18	WH	1659673C1

CONNECTOR 0593385C1  
BODY LOCK 0593387C1

**CLUTCH/CRUISE CONT. RELAY  
(149M)**

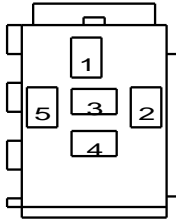


GAV	CIRCUIT	GAUGE	COLOR	TERMINAL
1	A97CN	18	VT	1659673C1
2	A97-GA	18	VT	1659673C1
3	A97AH	18	VT	1659673C1
4	-	-	-	-
5	A97AJ	18	VT	1659673C1

CONNECTOR 0593385C1  
BODY LOCK 0593387C1

**ABS TRAILER RELAY  
(152M)  
(LOCATED IN INSTRUMENT PANEL)**



GAV	CIRCUIT	GAUGE	COLOR	TERMINAL
1	A94AH	10	GY	1661710C1
2	A13CP	14	PK	1661709C1
3	-	-	-	-
4	A94AF	10	GY	1661710C1
5	A13-GCP	14	WH	1661709C1

CONNECTOR 0593385C1  
BODY LOCK 0593387C1

CHK	DATE	CHANGE	REV	REFERENCE	DRAWN	NAME
	MJV0330	MAR16		93408S	300371	CIRCUIT DIAGRAM, PAYSTAR
		PREFIX OF R/D 149M.			RELEASE NO.	DATE
					61879Y	17SEP09
						PART NO. <b>AE08058092</b> SHEET <b>017</b>

Figure 208 Connector Composites (148M / 149M / 152M)

13.22. CONNECTOR COMPOSITES (152M / 153A / 153M / 161M / 162F), P. 18

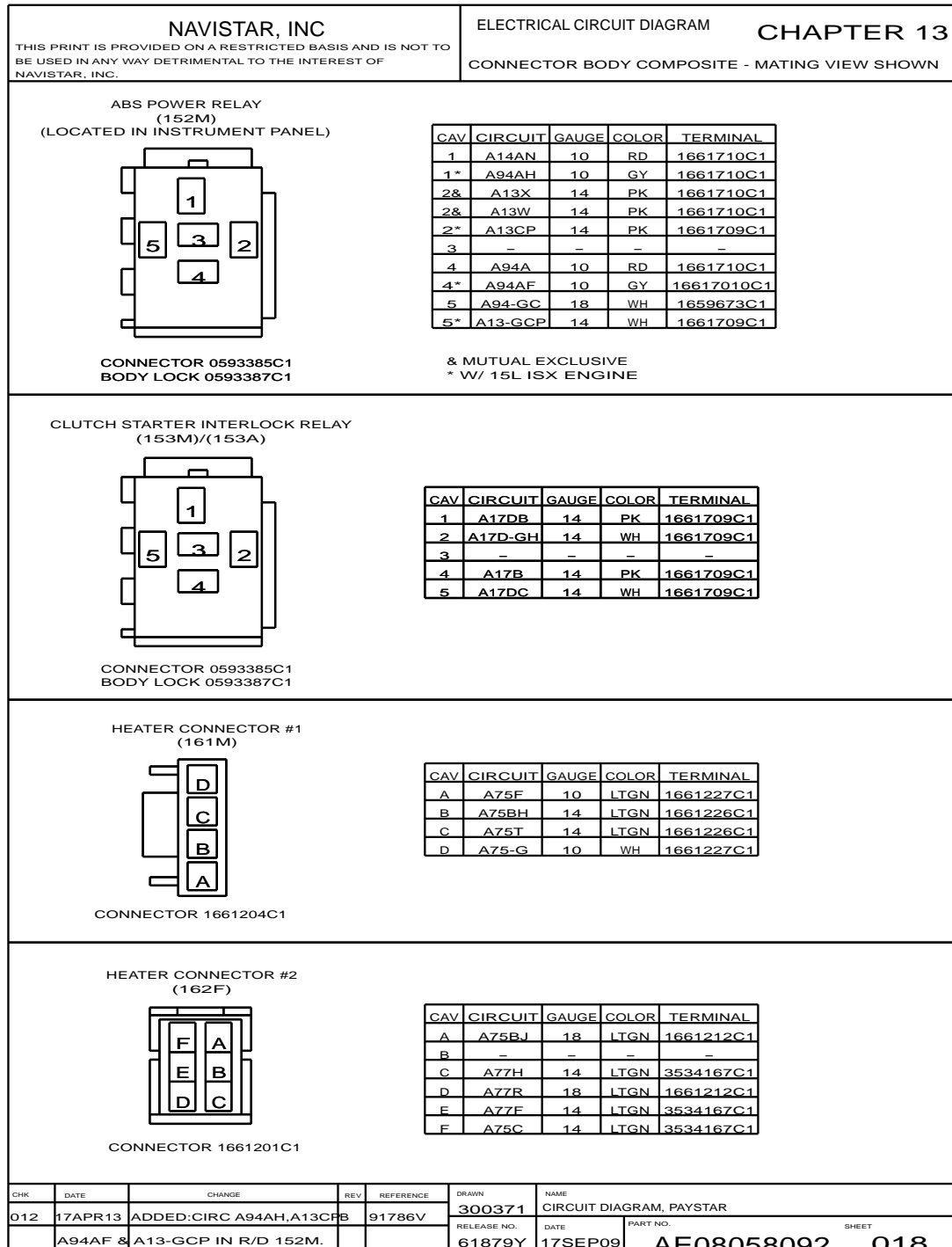


Figure 209 Connector Composites (152M / 153A / 153M / 161M / 162F)

13.23. CONNECTOR COMPOSITES (165 / 167M / 170M / 171M), P. 19

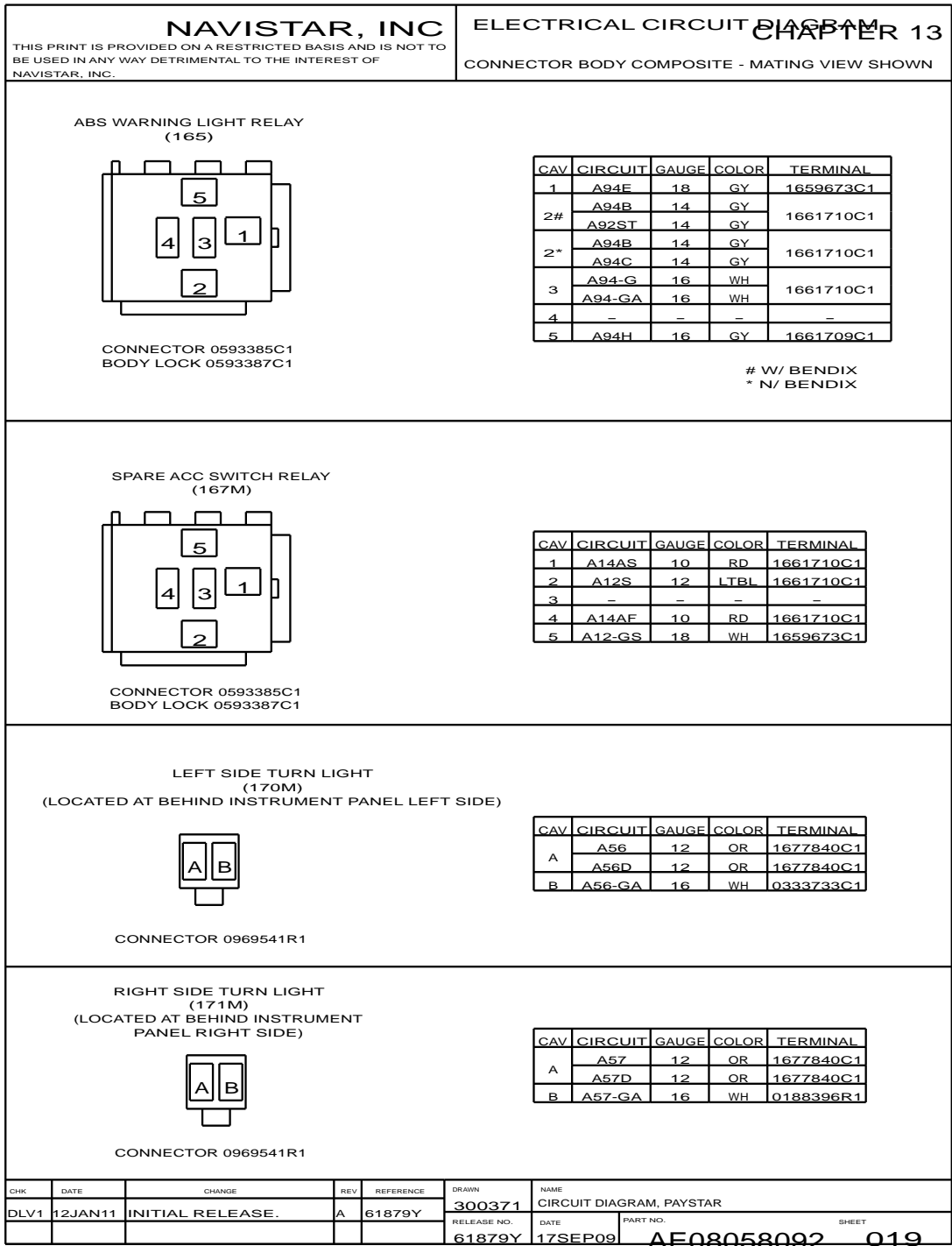


Figure 210 Connector Composites (165 / 167M / 170M / 171M)

13.24. CONNECTOR COMPOSITES (190), P. 20

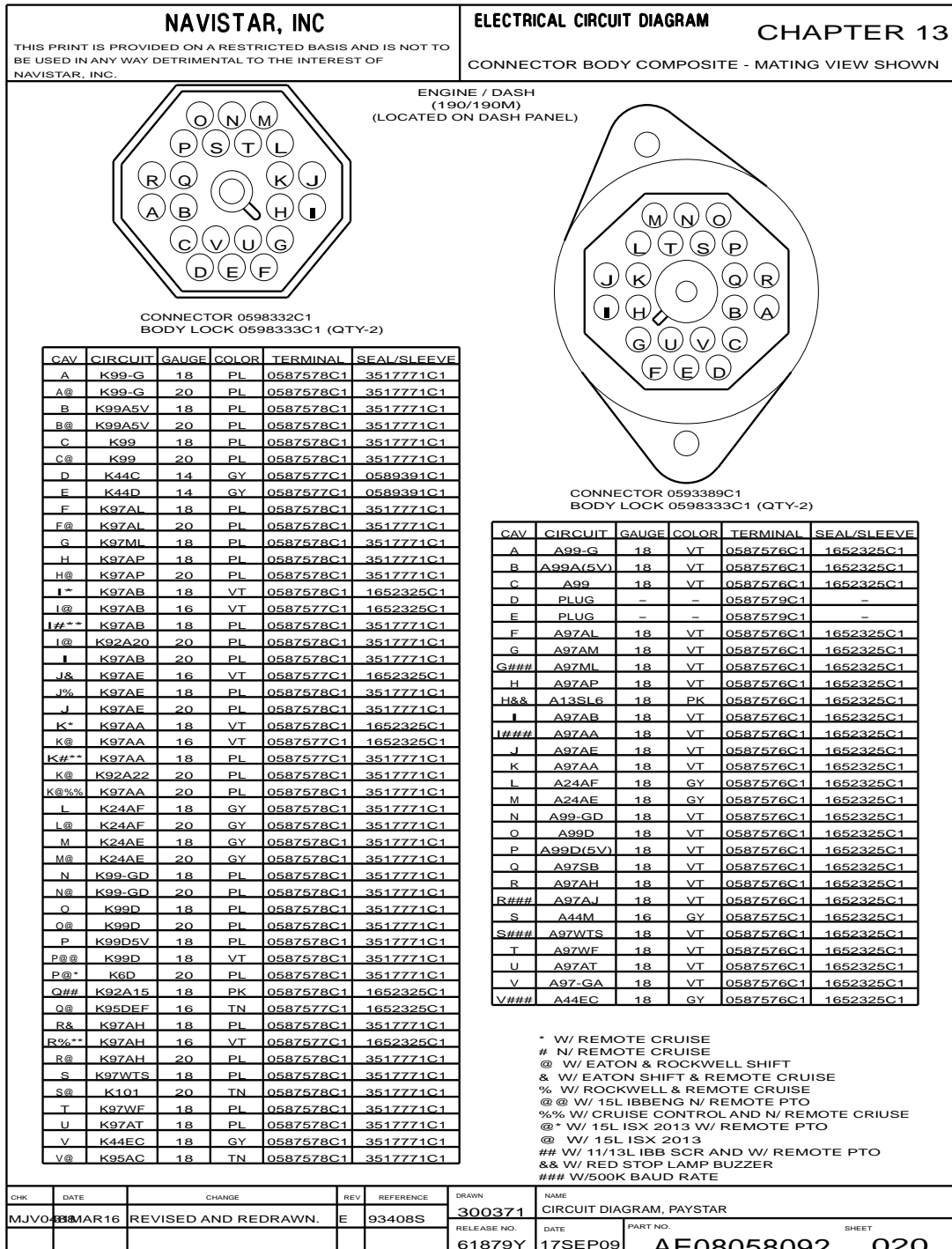


Figure 211 Connector Composites (190)

13.25. CONNECTOR COMPOSITES (200M / 201M), P. 21

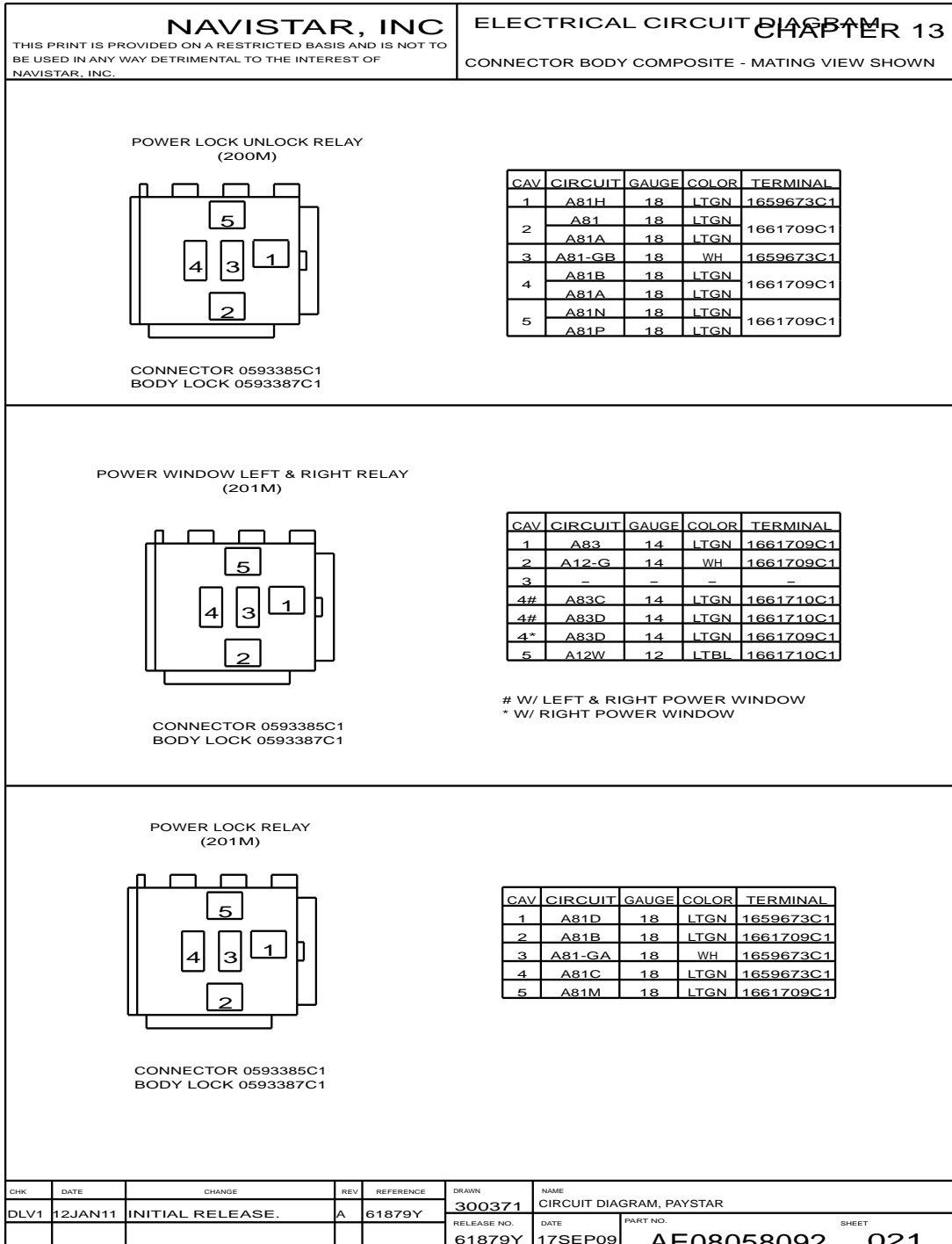


Figure 212 Connector Composites (200M / 201M)

13.26. CONNECTOR COMPOSITES (201M / 202M / 203 / 203G), P. 22

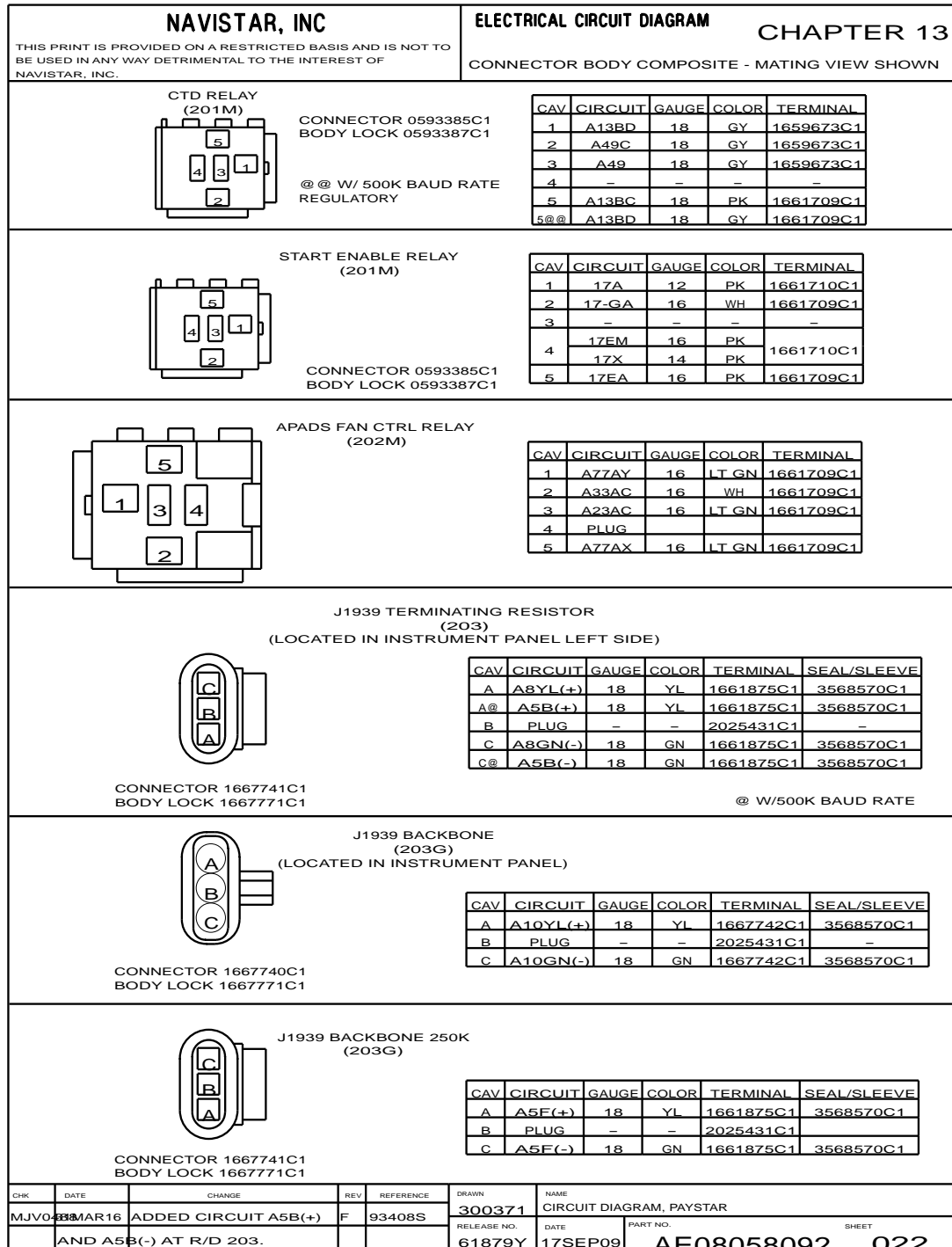


Figure 213 Connector Composites (201M / 202M / 203 / 203G)

13.27. CONNECTOR COMPOSITES (201M / 204 / 205), P. 22A

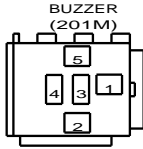
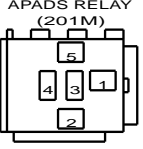
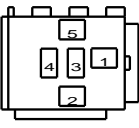

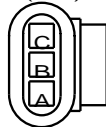
<b>NAVISTAR, INC</b>		<b>ELECTRICAL CIRCUIT DIAGRAM</b>		<b>CHAPTER 13</b>																																				
THIS PRINT IS PROVIDED ON A RESTRICTED BASIS AND IS NOT TO BE USED IN ANY WAY DETRIMENTAL TO THE INTEREST OF NAVISTAR, INC.		CONNECTOR BODY COMPOSITE - MATING VIEW SHOWN																																						
<p><b>BUZZER (201M)</b></p>  <p>CONNECTOR 0593385C1 BODY LOCK 0593387C1</p>		<table border="1" style="width:100%; border-collapse: collapse; font-size: x-small;"> <thead> <tr> <th>CAV</th> <th>CIRCUIT</th> <th>GAUGE</th> <th>COLOR</th> <th>TERMINAL</th> </tr> </thead> <tbody> <tr><td>1</td><td>BROWN</td><td>16</td><td>BN</td><td>1661709C1</td></tr> <tr><td>2</td><td>-</td><td>-</td><td>-</td><td>-</td></tr> <tr><td>3</td><td>A44</td><td>16</td><td>GY</td><td>1661710C1</td></tr> <tr><td>3</td><td>BLACK</td><td>16</td><td>BK</td><td>1661710C1</td></tr> <tr><td>4</td><td>-</td><td>-</td><td>-</td><td>-</td></tr> <tr><td>5</td><td>-</td><td>-</td><td>-</td><td>-</td></tr> </tbody> </table>				CAV	CIRCUIT	GAUGE	COLOR	TERMINAL	1	BROWN	16	BN	1661709C1	2	-	-	-	-	3	A44	16	GY	1661710C1	3	BLACK	16	BK	1661710C1	4	-	-	-	-	5	-	-	-	-
CAV	CIRCUIT	GAUGE	COLOR	TERMINAL																																				
1	BROWN	16	BN	1661709C1																																				
2	-	-	-	-																																				
3	A44	16	GY	1661710C1																																				
3	BLACK	16	BK	1661710C1																																				
4	-	-	-	-																																				
5	-	-	-	-																																				
<p><b>APADS RELAY (201M)</b></p>  <p>CONNECTOR 0593385C1 BODY LOCK 0593387C1</p>		<table border="1" style="width:100%; border-collapse: collapse; font-size: x-small;"> <thead> <tr> <th>CAV</th> <th>CIRCUIT</th> <th>GAUGE</th> <th>COLOR</th> <th>TERMINAL</th> </tr> </thead> <tbody> <tr><td>1</td><td>A77AC</td><td>16</td><td>LT GN</td><td>1661709C1</td></tr> <tr><td>2</td><td>A77-GAB</td><td>16</td><td>WH</td><td>1661709C1</td></tr> <tr><td>3</td><td>-</td><td>-</td><td>-</td><td>-</td></tr> <tr><td>4</td><td>A77AD</td><td>16</td><td>LT GN</td><td>1661709C1</td></tr> <tr><td>5</td><td>A77AB</td><td>16</td><td>PK</td><td>1661709C1</td></tr> </tbody> </table>				CAV	CIRCUIT	GAUGE	COLOR	TERMINAL	1	A77AC	16	LT GN	1661709C1	2	A77-GAB	16	WH	1661709C1	3	-	-	-	-	4	A77AD	16	LT GN	1661709C1	5	A77AB	16	PK	1661709C1					
CAV	CIRCUIT	GAUGE	COLOR	TERMINAL																																				
1	A77AC	16	LT GN	1661709C1																																				
2	A77-GAB	16	WH	1661709C1																																				
3	-	-	-	-																																				
4	A77AD	16	LT GN	1661709C1																																				
5	A77AB	16	PK	1661709C1																																				
<p><b>ENGINE STOP ALARM (201M)</b> (LOCATED IN INSTRUMENTAL PANEL)</p>  <p>CONNECTOR 0593385C1 BODY LOCK 0593387C1</p>		<table border="1" style="width:100%; border-collapse: collapse; font-size: x-small;"> <thead> <tr> <th>CAV</th> <th>CIRCUIT</th> <th>GAUGE</th> <th>COLOR</th> <th>TERMINAL</th> </tr> </thead> <tbody> <tr><td>1@</td><td>A13SL3</td><td>18</td><td>PK</td><td>1659673C1</td></tr> <tr><td>2</td><td>-</td><td>-</td><td>-</td><td>-</td></tr> <tr><td>3@</td><td>A13SL1</td><td>18</td><td>PK</td><td>1659673C1</td></tr> <tr><td>4</td><td>-</td><td>-</td><td>-</td><td>-</td></tr> <tr><td>5</td><td>-</td><td>-</td><td>-</td><td>-</td></tr> </tbody> </table> <p style="text-align: center; font-size: x-small;">@ W/ RED STOP LAMP BUZZER</p>				CAV	CIRCUIT	GAUGE	COLOR	TERMINAL	1@	A13SL3	18	PK	1659673C1	2	-	-	-	-	3@	A13SL1	18	PK	1659673C1	4	-	-	-	-	5	-	-	-	-					
CAV	CIRCUIT	GAUGE	COLOR	TERMINAL																																				
1@	A13SL3	18	PK	1659673C1																																				
2	-	-	-	-																																				
3@	A13SL1	18	PK	1659673C1																																				
4	-	-	-	-																																				
5	-	-	-	-																																				
<p><b>J1939 TERMINATING RESISTOR 250K (204)</b> (LOCATED IN INSTRUMENT PANEL)</p>  <p>CONNECTOR 1667741C1 BODY LOCK 1667771C1</p>		<table border="1" style="width:100%; border-collapse: collapse; font-size: x-small;"> <thead> <tr> <th>CAV</th> <th>CIRCUIT</th> <th>GAUGE</th> <th>COLOR</th> <th>TERMINAL</th> <th>SEAL/SLV</th> </tr> </thead> <tbody> <tr><td>A</td><td>A5K(+)</td><td>18</td><td>YL</td><td>1661875C1</td><td>3568570C1</td></tr> <tr><td>B</td><td>PLUG</td><td>-</td><td>-</td><td>-</td><td>2025431C1</td></tr> <tr><td>C</td><td>A5K(-)</td><td>18</td><td>GN</td><td>1661875C1</td><td>3568570C1</td></tr> </tbody> </table>				CAV	CIRCUIT	GAUGE	COLOR	TERMINAL	SEAL/SLV	A	A5K(+)	18	YL	1661875C1	3568570C1	B	PLUG	-	-	-	2025431C1	C	A5K(-)	18	GN	1661875C1	3568570C1											
CAV	CIRCUIT	GAUGE	COLOR	TERMINAL	SEAL/SLV																																			
A	A5K(+)	18	YL	1661875C1	3568570C1																																			
B	PLUG	-	-	-	2025431C1																																			
C	A5K(-)	18	GN	1661875C1	3568570C1																																			
<p><b>J1939 TERM RESIST BACKBONE 500K (205)</b></p>  <p>CONNECTOR 1667741C1 BODY LOCK 1667771C1</p>		<table border="1" style="width:100%; border-collapse: collapse; font-size: x-small;"> <thead> <tr> <th>CAV</th> <th>CIRCUIT</th> <th>GAUGE</th> <th>COLOR</th> <th>TERMINAL</th> <th>SEAL/SLV</th> </tr> </thead> <tbody> <tr><td>A</td><td>A5M(+)</td><td>18</td><td>YL</td><td>1661875C1</td><td>3568570C1</td></tr> <tr><td>B</td><td>PLUG</td><td>-</td><td>-</td><td>-</td><td>2025431C1</td></tr> <tr><td>C</td><td>A5M(-)</td><td>18</td><td>GN</td><td>1661875C1</td><td>3568570C1</td></tr> </tbody> </table>				CAV	CIRCUIT	GAUGE	COLOR	TERMINAL	SEAL/SLV	A	A5M(+)	18	YL	1661875C1	3568570C1	B	PLUG	-	-	-	2025431C1	C	A5M(-)	18	GN	1661875C1	3568570C1											
CAV	CIRCUIT	GAUGE	COLOR	TERMINAL	SEAL/SLV																																			
A	A5M(+)	18	YL	1661875C1	3568570C1																																			
B	PLUG	-	-	-	2025431C1																																			
C	A5M(-)	18	GN	1661875C1	3568570C1																																			
CHK	DATE	CHANGE	REV	REFERENCE	DRAWN	NAME																																		
MJVO	13MAR16	REVISED AND REDRAWN.	E	93408S	MJVO088	CIRCUIT DIAGRAM, PAYSTAR																																		
RELEASE NO.		DATE		PART NO.		SHEET																																		
91786V		12MAR13		AE08058092		22A																																		

Figure 214 Connector Composites (201M / 204 / 205)



13.28. CONNECTOR COMPOSITES (205G / 205M), P. 22B

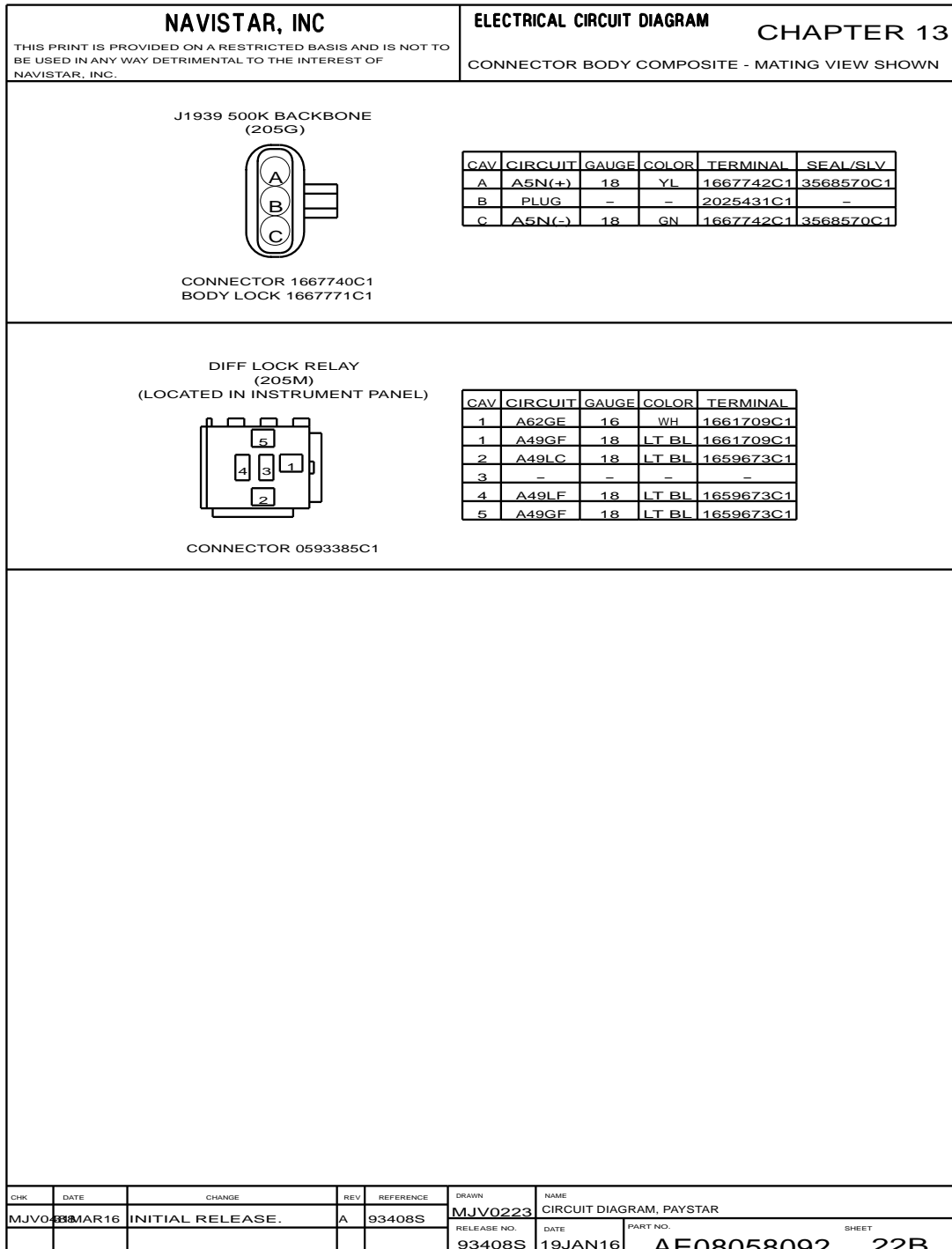


Figure 215 Connector Composites (205G / 205M)

13.29. CONNECTOR COMPOSITES (209 / 211M / 214 / 221), P. 23

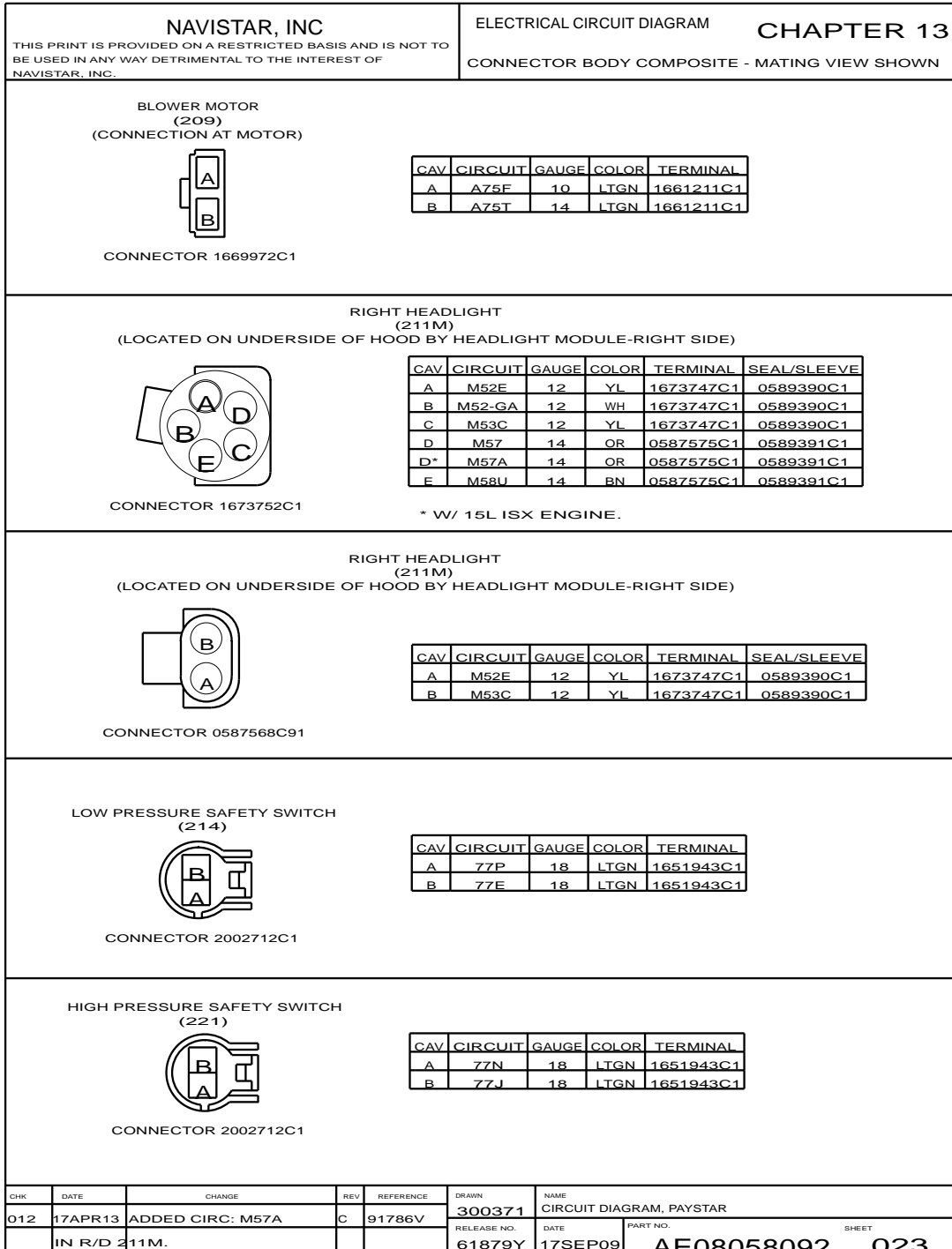


Figure 216 Connector Composites (209 / 211M / 214 / 221)

13.30. CONNECTOR COMPOSITES (227 / 228 / 230 / 236 / 236F / 244F), P. 24

<b>NAVISTAR, INC</b> <small>THIS PRINT IS PROVIDED ON A RESTRICTED BASIS AND IS NOT TO BE USED IN ANY WAY DETRIMENTAL TO THE INTEREST OF NAVISTAR, INC.</small>				ELECTRICAL CIRCUIT DIAGRAM <b>CHAPTER 13</b> CONNECTOR BODY COMPOSITE - MATING VIEW SHOWN																																																													
<p>FAN SOLENOID (227) (LOCATED ON ENGINE)</p> <p>CONNECTOR 0587568C91</p>		<p>CONNECTOR 3522068C1 BODY LOCK 1661874C1</p>		<table border="1" style="width:100%; border-collapse: collapse;"> <thead> <tr> <th>CAV</th><th>CIRCUIT</th><th>GAUGE</th><th>COLOR</th><th>TERMINAL</th><th>SEAL/SLEEVE</th></tr> </thead> <tbody> <tr> <td>A</td><td>KC23</td><td>18</td><td>TN</td><td>0587576C1</td><td>3517771C1</td></tr> <tr> <td>B</td><td>K23-G</td><td>18</td><td>WH</td><td>0587576C1</td><td>3517771C1</td></tr> </tbody> </table>		CAV	CIRCUIT	GAUGE	COLOR	TERMINAL	SEAL/SLEEVE	A	KC23	18	TN	0587576C1	3517771C1	B	K23-G	18	WH	0587576C1	3517771C1	<table border="1" style="width:100%; border-collapse: collapse;"> <thead> <tr> <th>CAV</th><th>CIRCUIT</th><th>GAUGE</th><th>COLOR</th><th>TERMINAL</th><th>SEAL/SLEEVE</th></tr> </thead> <tbody> <tr> <td>A</td><td>KC23</td><td>18</td><td>TN</td><td>1661875C1</td><td>3517771C1</td></tr> <tr> <td>B</td><td>K23-G</td><td>18</td><td>WH</td><td>1661875C1</td><td>3517771C1</td></tr> </tbody> </table>		CAV	CIRCUIT	GAUGE	COLOR	TERMINAL	SEAL/SLEEVE	A	KC23	18	TN	1661875C1	3517771C1	B	K23-G	18	WH	1661875C1	3517771C1																						
CAV	CIRCUIT	GAUGE	COLOR	TERMINAL	SEAL/SLEEVE																																																												
A	KC23	18	TN	0587576C1	3517771C1																																																												
B	K23-G	18	WH	0587576C1	3517771C1																																																												
CAV	CIRCUIT	GAUGE	COLOR	TERMINAL	SEAL/SLEEVE																																																												
A	KC23	18	TN	1661875C1	3517771C1																																																												
B	K23-G	18	WH	1661875C1	3517771C1																																																												
<p>AC PRESSURE SWITCH (228) (LOCATED ON ENGINE)</p> <p>CONNECTOR 0587568C91</p>		<table border="1" style="width:100%; border-collapse: collapse;"> <thead> <tr> <th>CAV</th><th>CIRCUIT</th><th>GAUGE</th><th>COLOR</th><th>TERMINAL</th><th>SEAL/SLEEVE</th></tr> </thead> <tbody> <tr> <td>A</td><td>K31</td><td>18</td><td>TN</td><td>2036586C1</td><td>-</td></tr> <tr> <td>*A</td><td>K23C</td><td>18</td><td>TN</td><td>0587576C1</td><td>1652325C1</td></tr> <tr> <td>#A</td><td>K23C</td><td>18</td><td>TN</td><td>0587576C1</td><td>3517771C1</td></tr> <tr> <td>A@</td><td>K23C</td><td>20</td><td>TN</td><td>0587576C1</td><td>3517771C1</td></tr> <tr> <td>B</td><td>K31-G</td><td>16</td><td>TN</td><td>2036586C1</td><td>-</td></tr> <tr> <td>*B</td><td>K23T</td><td>18</td><td>TN</td><td>0587576C1</td><td>1652325C1</td></tr> <tr> <td>#B</td><td>K23T</td><td>18</td><td>TN</td><td>0587576C1</td><td>3517771C1</td></tr> <tr> <td>B@</td><td>K23-G</td><td>18</td><td>PK</td><td>0587576C1</td><td>1652325C1</td></tr> </tbody> </table> <p style="text-align: center;">* W/AIR CONDITIONING &amp; W/ FANOVERVERRIDE &amp; N/ APADS # W/AIRCONDITIONING &amp; N/FAN OVERRIDE;APADS @ W/15L ISX 2013M</p>				CAV	CIRCUIT	GAUGE	COLOR	TERMINAL	SEAL/SLEEVE	A	K31	18	TN	2036586C1	-	*A	K23C	18	TN	0587576C1	1652325C1	#A	K23C	18	TN	0587576C1	3517771C1	A@	K23C	20	TN	0587576C1	3517771C1	B	K31-G	16	TN	2036586C1	-	*B	K23T	18	TN	0587576C1	1652325C1	#B	K23T	18	TN	0587576C1	3517771C1	B@	K23-G	18	PK	0587576C1	1652325C1						
CAV	CIRCUIT	GAUGE	COLOR	TERMINAL	SEAL/SLEEVE																																																												
A	K31	18	TN	2036586C1	-																																																												
*A	K23C	18	TN	0587576C1	1652325C1																																																												
#A	K23C	18	TN	0587576C1	3517771C1																																																												
A@	K23C	20	TN	0587576C1	3517771C1																																																												
B	K31-G	16	TN	2036586C1	-																																																												
*B	K23T	18	TN	0587576C1	1652325C1																																																												
#B	K23T	18	TN	0587576C1	3517771C1																																																												
B@	K23-G	18	PK	0587576C1	1652325C1																																																												
<p>BACK - UP LIGHT SWITCH (230) (LOCATED ON TOP OF TRANSMISSION)</p> <p>CONNECTOR AM-89000 #7</p>		<table border="1" style="width:100%; border-collapse: collapse;"> <thead> <tr> <th>CAV</th><th>CIRCUIT</th><th>GAUGE</th><th>COLOR</th><th>TERMINAL</th><th>SEAL/SLEEVE</th></tr> </thead> <tbody> <tr> <td>A</td><td>BLACK</td><td>16</td><td>BK</td><td>1661875C1</td><td>1661872C1</td></tr> <tr> <td>B</td><td>WHITE</td><td>16</td><td>WH</td><td>1661875C1</td><td>1661872C1</td></tr> <tr> <td>C</td><td>-</td><td>-</td><td>-</td><td>-</td><td>-</td></tr> </tbody> </table>				CAV	CIRCUIT	GAUGE	COLOR	TERMINAL	SEAL/SLEEVE	A	BLACK	16	BK	1661875C1	1661872C1	B	WHITE	16	WH	1661875C1	1661872C1	C	-	-	-	-	-																																				
CAV	CIRCUIT	GAUGE	COLOR	TERMINAL	SEAL/SLEEVE																																																												
A	BLACK	16	BK	1661875C1	1661872C1																																																												
B	WHITE	16	WH	1661875C1	1661872C1																																																												
C	-	-	-	-	-																																																												
<p>XMSN OIL TEMP SENDER (236) (LOCATED ON XMSN)</p> <p>CONNECTOR 2036584C1</p>		<table border="1" style="width:100%; border-collapse: collapse;"> <thead> <tr> <th>CAV</th><th>CIRCUIT</th><th>GAUGE</th><th>COLOR</th><th>TERMINAL</th></tr> </thead> <tbody> <tr> <td>A</td><td>K31</td><td>18</td><td>TN</td><td>2036586C1</td></tr> <tr> <td>B</td><td>K31-G</td><td>16</td><td>TN</td><td>2036586C1</td></tr> </tbody> </table>				CAV	CIRCUIT	GAUGE	COLOR	TERMINAL	A	K31	18	TN	2036586C1	B	K31-G	16	TN	2036586C1																																													
CAV	CIRCUIT	GAUGE	COLOR	TERMINAL																																																													
A	K31	18	TN	2036586C1																																																													
B	K31-G	16	TN	2036586C1																																																													
<p>AUTO XMSN TEMP SENDER (236F) (LOCATED ON XMSN)</p> <p>CONNECTOR 2036584C1</p>		<table border="1" style="width:100%; border-collapse: collapse;"> <thead> <tr> <th>CAV</th><th>CIRCUIT</th><th>GAUGE</th><th>COLOR</th><th>TERMINAL</th></tr> </thead> <tbody> <tr> <td>A</td><td>K31</td><td>16</td><td>TN</td><td>2036586C1</td></tr> <tr> <td>*A</td><td>K31B</td><td>16</td><td>TN</td><td>2036586C1</td></tr> <tr> <td>B</td><td>K31-G</td><td>16</td><td>WH</td><td>2036586C1</td></tr> </tbody> </table> <p style="text-align: center;">* W/15L DIESEL ENGINE</p>				CAV	CIRCUIT	GAUGE	COLOR	TERMINAL	A	K31	16	TN	2036586C1	*A	K31B	16	TN	2036586C1	B	K31-G	16	WH	2036586C1																																								
CAV	CIRCUIT	GAUGE	COLOR	TERMINAL																																																													
A	K31	16	TN	2036586C1																																																													
*A	K31B	16	TN	2036586C1																																																													
B	K31-G	16	WH	2036586C1																																																													
<p>SHIFT TOWER CRUISE CONTROL (244F)</p> <p>CONNECTOR 2024437C1 BODY LOCK 2011364C1</p>		<table border="1" style="width:100%; border-collapse: collapse;"> <thead> <tr> <th>CAV</th><th>CIRCUIT</th><th>GAUGE</th><th>COLOR</th><th>TERMINAL</th><th>SEAL/SLEEVE</th></tr> </thead> <tbody> <tr> <td>A*</td><td>K97-GC</td><td>16</td><td>VT</td><td>1667742C1</td><td>1661872C1</td></tr> <tr> <td>A#</td><td>K97-GC</td><td>18</td><td>VT</td><td>1667742C1</td><td>1661872C1</td></tr> <tr> <td>A@</td><td>K97-GA</td><td>16</td><td>VT</td><td>1667742C1</td><td>1661872C1</td></tr> <tr> <td>A@</td><td>K97-GC</td><td>18</td><td>WH</td><td>1667742C1</td><td>1661872C1</td></tr> <tr> <td>B</td><td>K97AE2</td><td>16</td><td>VT</td><td>1667742C1</td><td>1661872C1</td></tr> <tr> <td>C</td><td>K97AN</td><td>18</td><td>PL</td><td>1667742C1</td><td>3568570C1</td></tr> <tr> <td>D</td><td>K97AH</td><td>16</td><td>VT</td><td>1667742C1</td><td>1661872C1</td></tr> <tr> <td>E</td><td>K97AA2</td><td>16</td><td>VT</td><td>1667742C1</td><td>1661872C1</td></tr> <tr> <td>F</td><td>K97AB2</td><td>16</td><td>VT</td><td>1667742C1</td><td>1661872C1</td></tr> </tbody> </table> <p style="text-align: center;">* W/ ROCKWELL &amp; REMOTE CRUISE # W/ REMOTE CRUISE @ W/ 11/13L IBB SCR 2013</p>				CAV	CIRCUIT	GAUGE	COLOR	TERMINAL	SEAL/SLEEVE	A*	K97-GC	16	VT	1667742C1	1661872C1	A#	K97-GC	18	VT	1667742C1	1661872C1	A@	K97-GA	16	VT	1667742C1	1661872C1	A@	K97-GC	18	WH	1667742C1	1661872C1	B	K97AE2	16	VT	1667742C1	1661872C1	C	K97AN	18	PL	1667742C1	3568570C1	D	K97AH	16	VT	1667742C1	1661872C1	E	K97AA2	16	VT	1667742C1	1661872C1	F	K97AB2	16	VT	1667742C1	1661872C1
CAV	CIRCUIT	GAUGE	COLOR	TERMINAL	SEAL/SLEEVE																																																												
A*	K97-GC	16	VT	1667742C1	1661872C1																																																												
A#	K97-GC	18	VT	1667742C1	1661872C1																																																												
A@	K97-GA	16	VT	1667742C1	1661872C1																																																												
A@	K97-GC	18	WH	1667742C1	1661872C1																																																												
B	K97AE2	16	VT	1667742C1	1661872C1																																																												
C	K97AN	18	PL	1667742C1	3568570C1																																																												
D	K97AH	16	VT	1667742C1	1661872C1																																																												
E	K97AA2	16	VT	1667742C1	1661872C1																																																												
F	K97AB2	16	VT	1667742C1	1661872C1																																																												
<table border="1" style="width:100%; border-collapse: collapse;"> <thead> <tr> <th>CHK</th><th>DATE</th><th>CHANGE</th><th>REV</th><th>REFERENCE</th></tr> </thead> <tbody> <tr> <td>012</td><td>17APR13</td><td>ADDED CIRC:K23C,K23-G</td><td>C</td><td>91786V</td></tr> <tr> <td></td><td></td><td>IN R/D 228 &amp; K97-GA,K97-GC IN R/D 244F.</td><td></td><td></td></tr> </tbody> </table>		CHK	DATE	CHANGE	REV	REFERENCE	012	17APR13	ADDED CIRC:K23C,K23-G	C	91786V			IN R/D 228 & K97-GA,K97-GC IN R/D 244F.			<table border="1" style="width:100%; border-collapse: collapse;"> <thead> <tr> <th>DRAWN</th><th>NAME</th></tr> </thead> <tbody> <tr> <td>300371</td><td>CIRCUIT DIAGRAM, PAYSTAR</td></tr> <tr> <td>RELEASE NO.</td><td>DATE</td></tr> <tr> <td>61879Y</td><td>17SEP09</td></tr> </tbody> </table>		DRAWN	NAME	300371	CIRCUIT DIAGRAM, PAYSTAR	RELEASE NO.	DATE	61879Y	17SEP09	<table border="1" style="width:100%; border-collapse: collapse;"> <thead> <tr> <th>PART NO.</th><th>SHEET</th></tr> </thead> <tbody> <tr> <td>AE08058092</td><td>024</td></tr> </tbody> </table>		PART NO.	SHEET	AE08058092	024																																	
CHK	DATE	CHANGE	REV	REFERENCE																																																													
012	17APR13	ADDED CIRC:K23C,K23-G	C	91786V																																																													
		IN R/D 228 & K97-GA,K97-GC IN R/D 244F.																																																															
DRAWN	NAME																																																																
300371	CIRCUIT DIAGRAM, PAYSTAR																																																																
RELEASE NO.	DATE																																																																
61879Y	17SEP09																																																																
PART NO.	SHEET																																																																
AE08058092	024																																																																

Figure 217 Connector Composites (227 / 228 / 230 / 236 / 236F / 244F)

13.31. CONNECTOR COMPOSITES (267M / \*275 / 289F / 290F / 291), P. 25

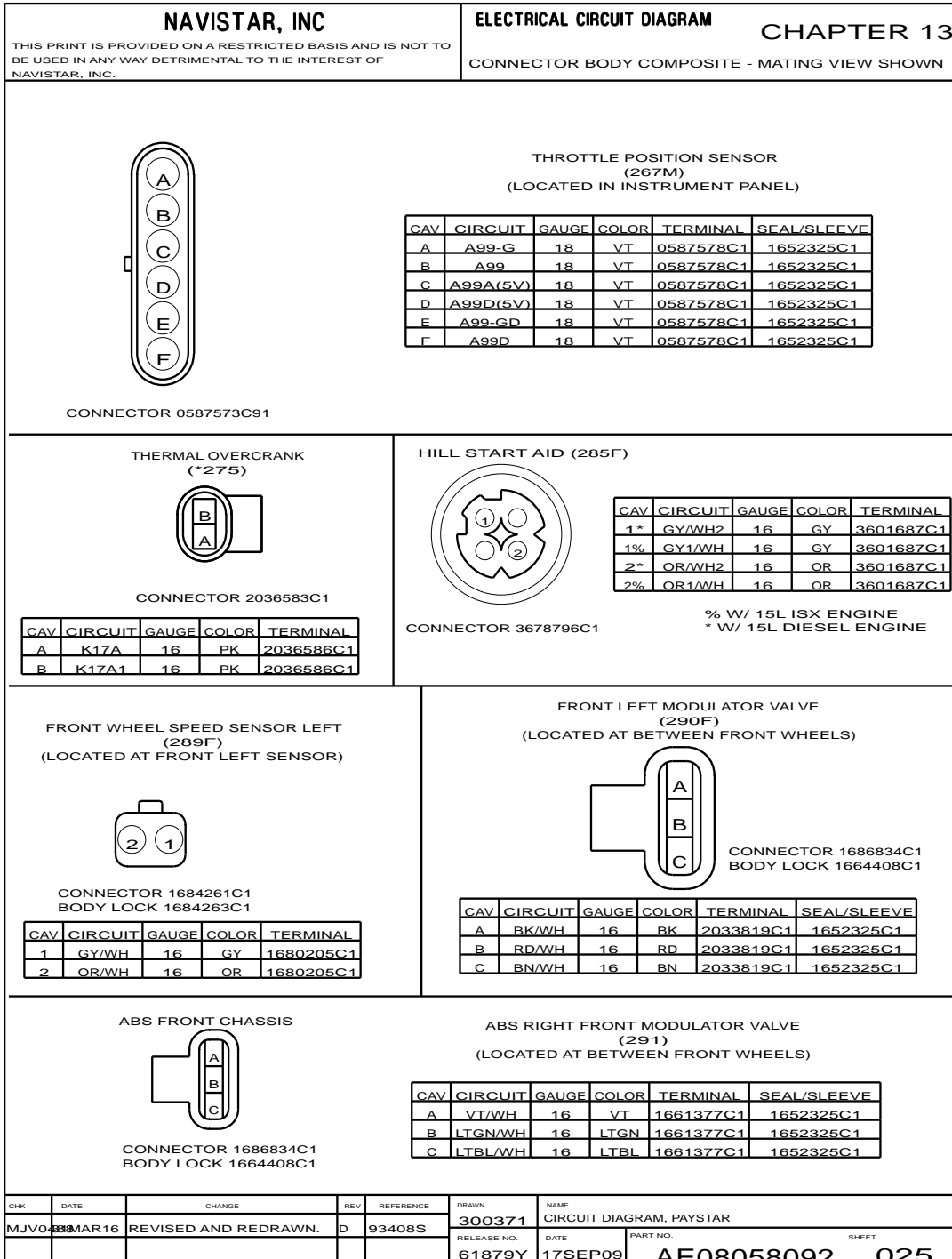


Figure 218 Connector Composites (267M / \*275 / 289F / 290F / 291)

13.32. CONNECTOR COMPOSITES (291F / 292F / 294A / 294F), P. 26

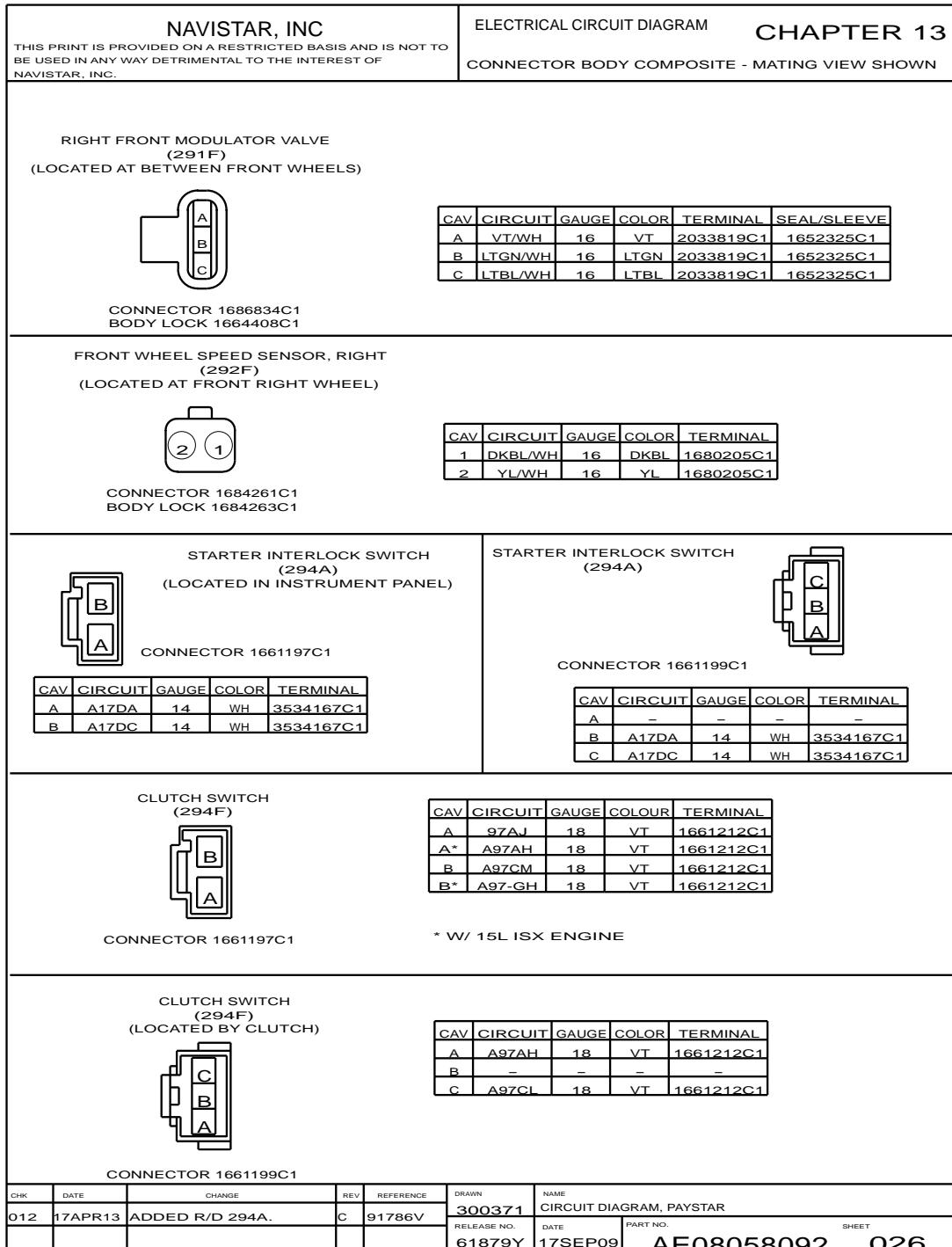


Figure 219 Connector Composites (291F / 292F / 294A / 294F)

13.33. CONNECTOR COMPOSITES (296M / 298 / 299 / 303F), P. 27

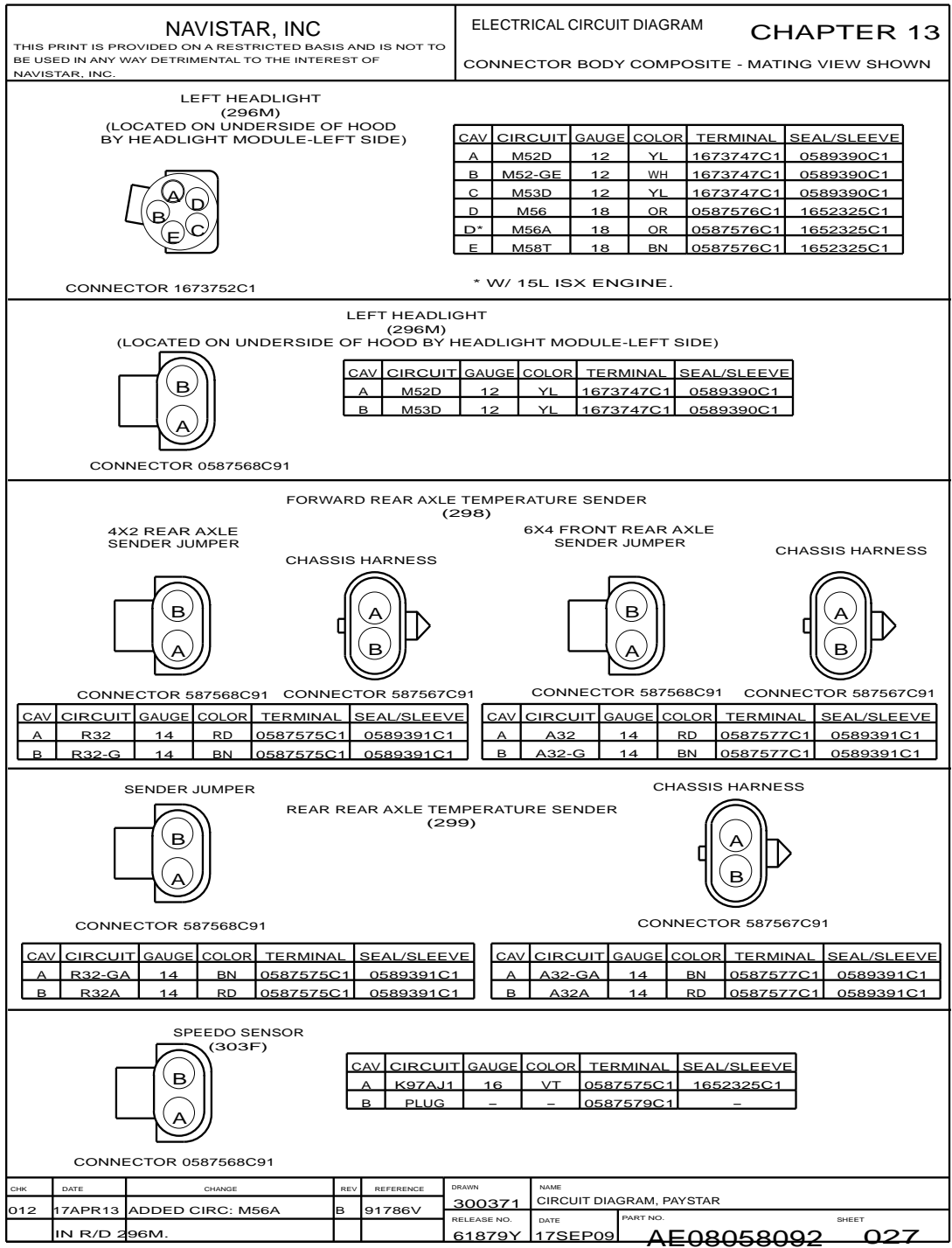


Figure 220 Connector Composites (296M / 298 / 299 / 303F)

13.34. CONNECTOR COMPOSITES (303M / 311 / 312 / 313 / 314M), P. 28

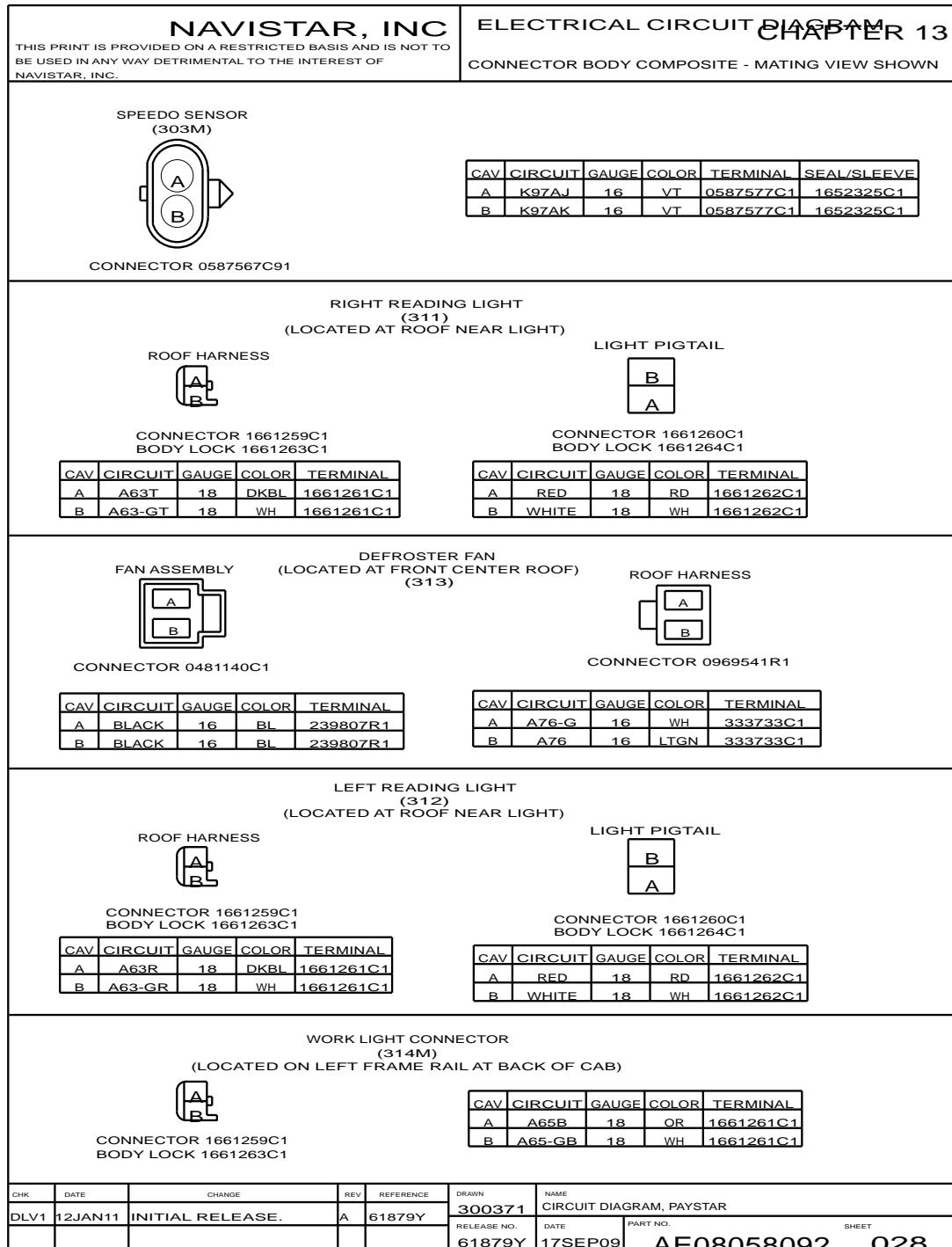


Figure 221 Connector Composites (303M / 311 / 312 / 313 / 314M)

13.35. CONNECTOR COMPOSITES (320 / 325 / 340), P. 29

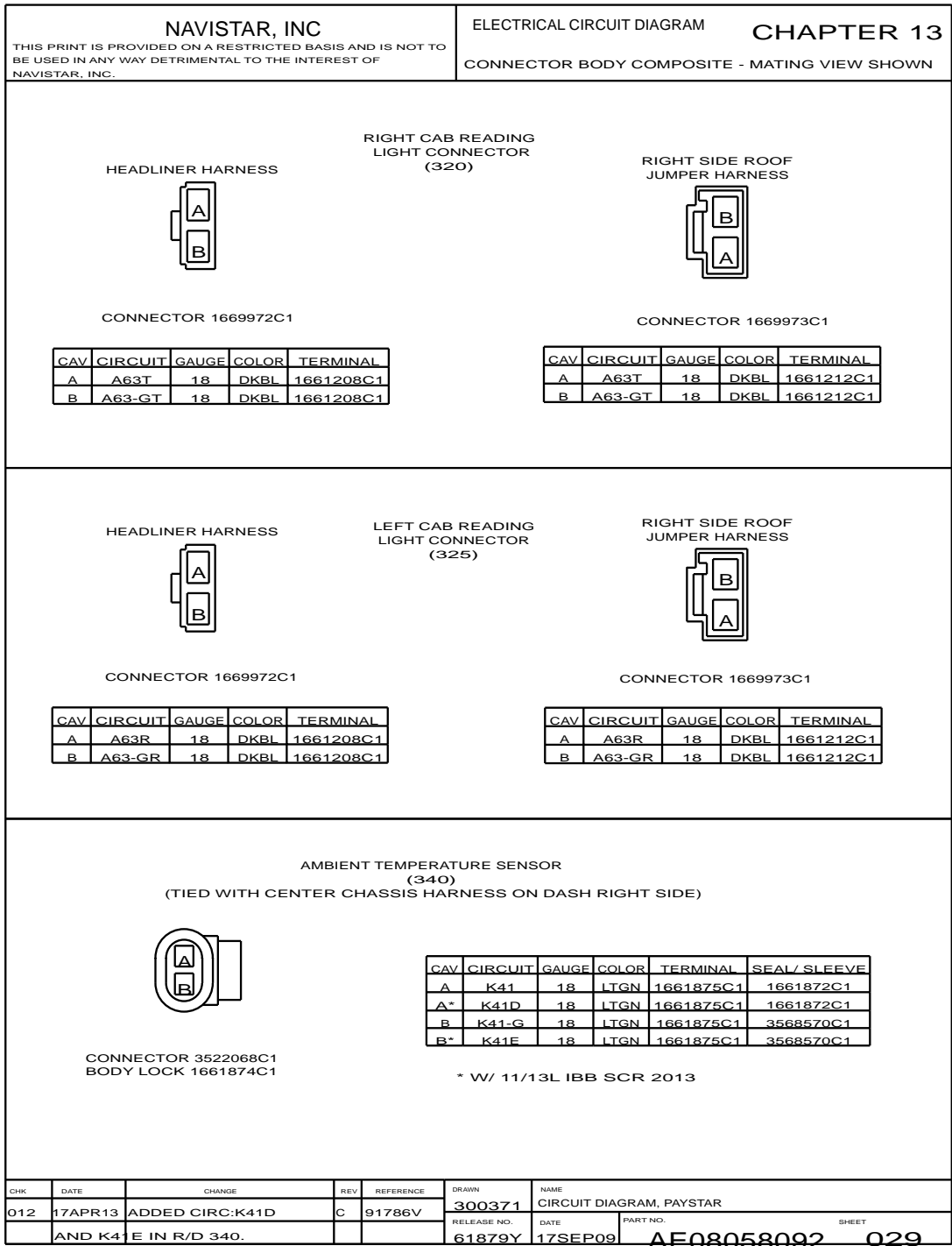


Figure 222 Connector Composites (320 / 325 / 340)



13.36. CONNECTOR COMPOSITES (345M / 351 / 352), P. 29A

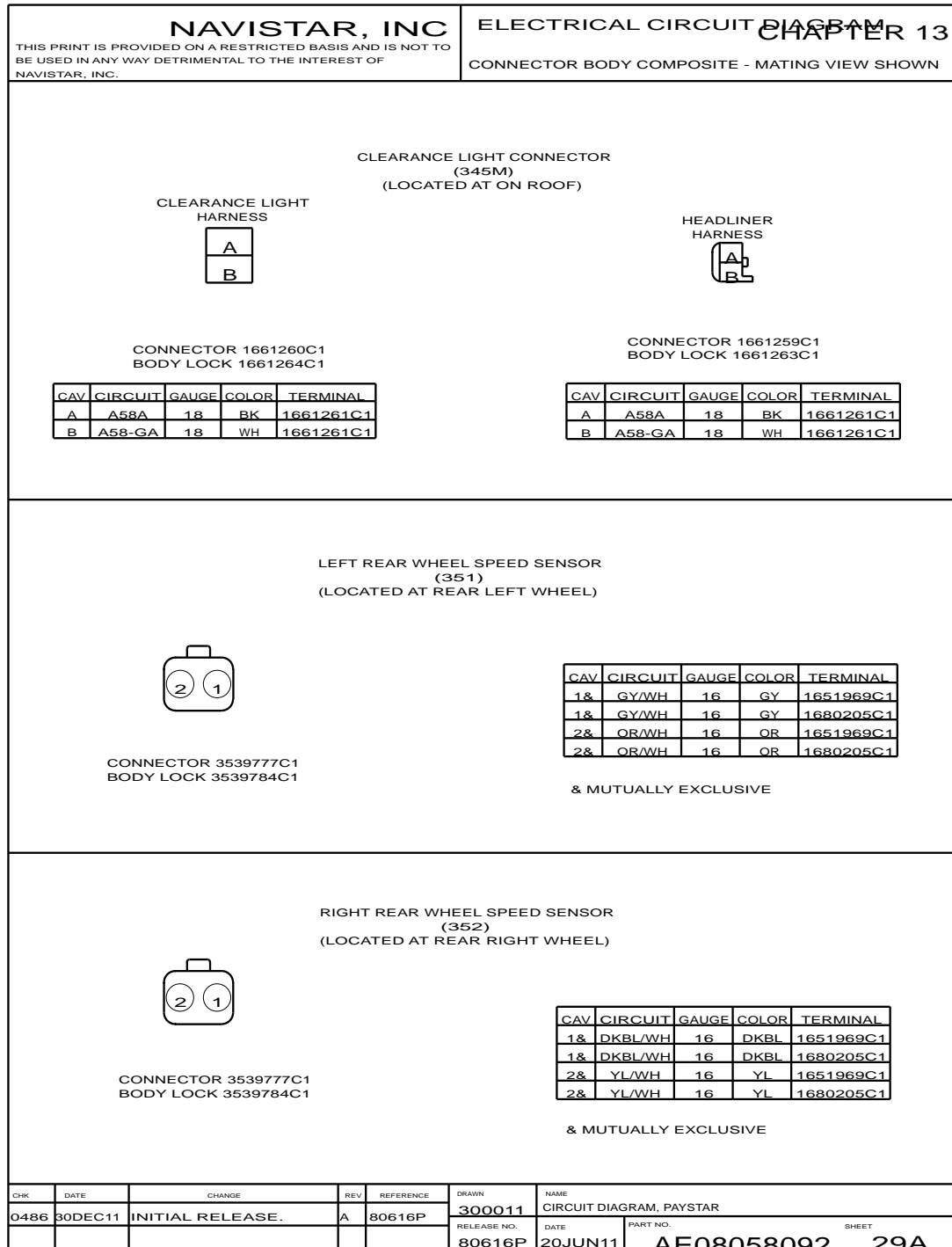


Figure 223 Connector Composites (345M / 351 / 352)

13.37. CONNECTOR COMPOSITES (353 / 354 / 355), P. 30

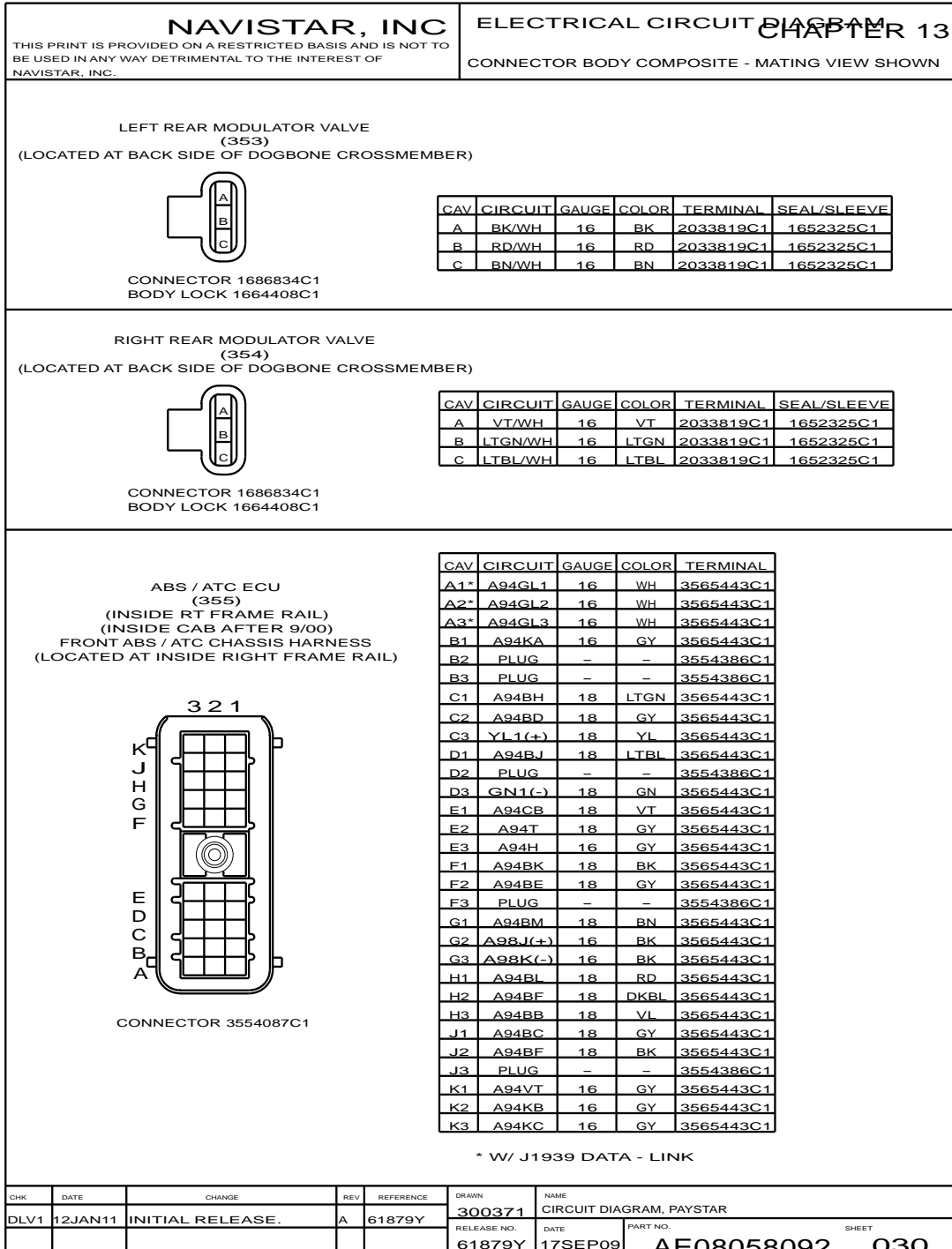


Figure 224 Connector Composites (353 / 354 / 355)

13.38. CONNECTOR COMPOSITES (360 / 393 / 393B / 412A / 420M), P. 31

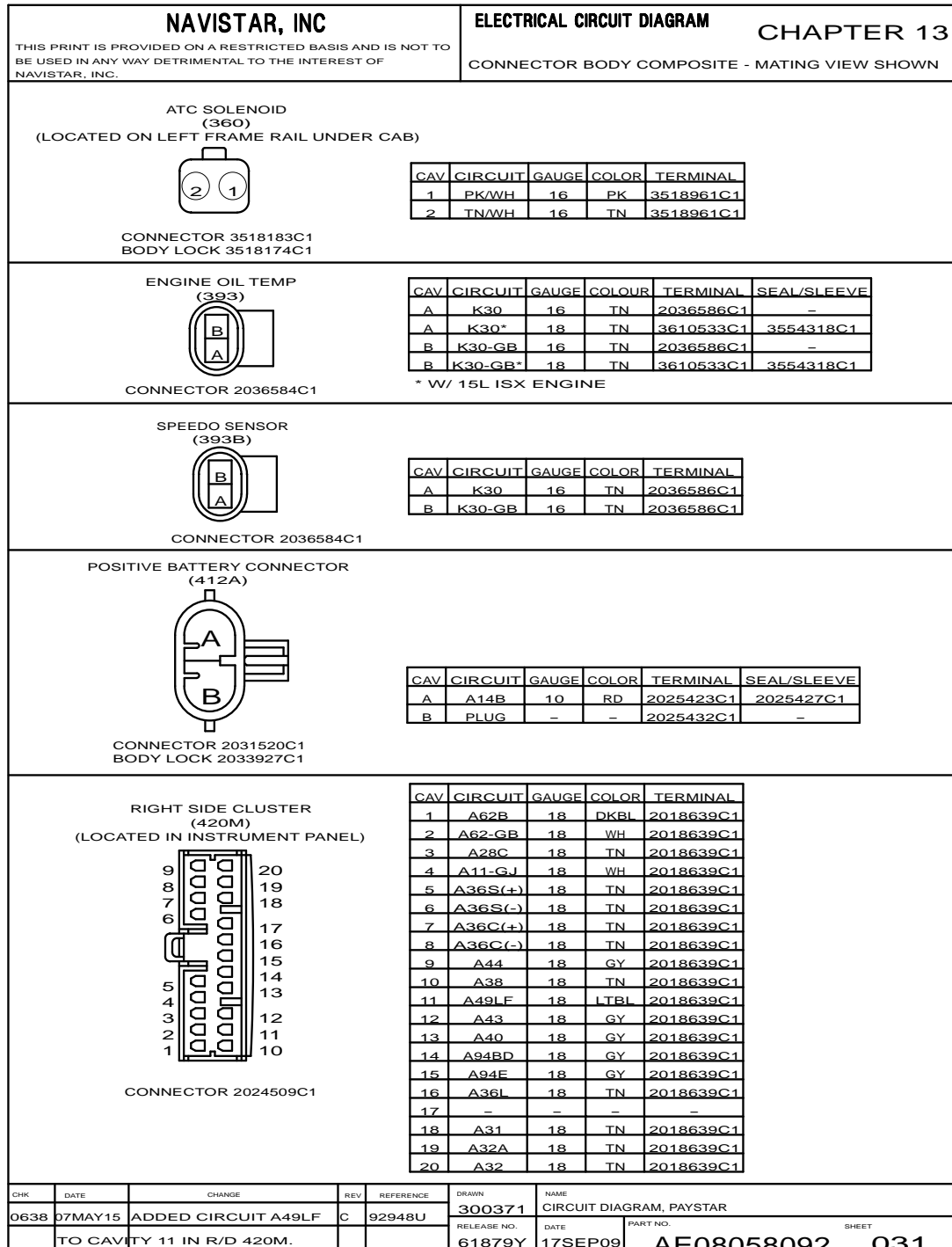


Figure 225 Connector Composites (360 / 393 / 393B / 412A / 420M)

13.39. CONNECTOR COMPOSITES (421M / 422M), P. 32

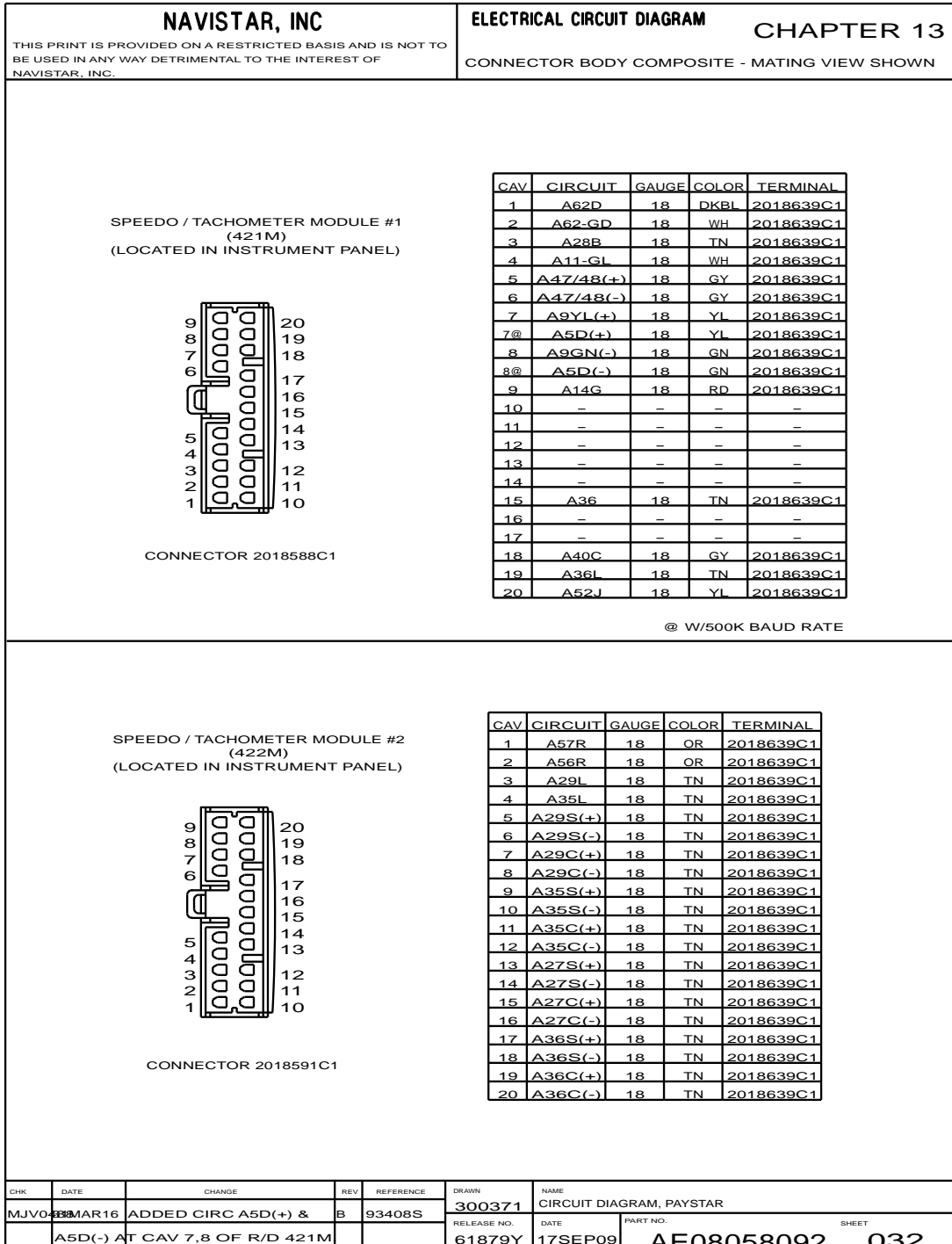


Figure 226 Connector Composites (421M / 422M)

13.40. CONNECTOR COMPOSITES (423M / 424M), P. 33

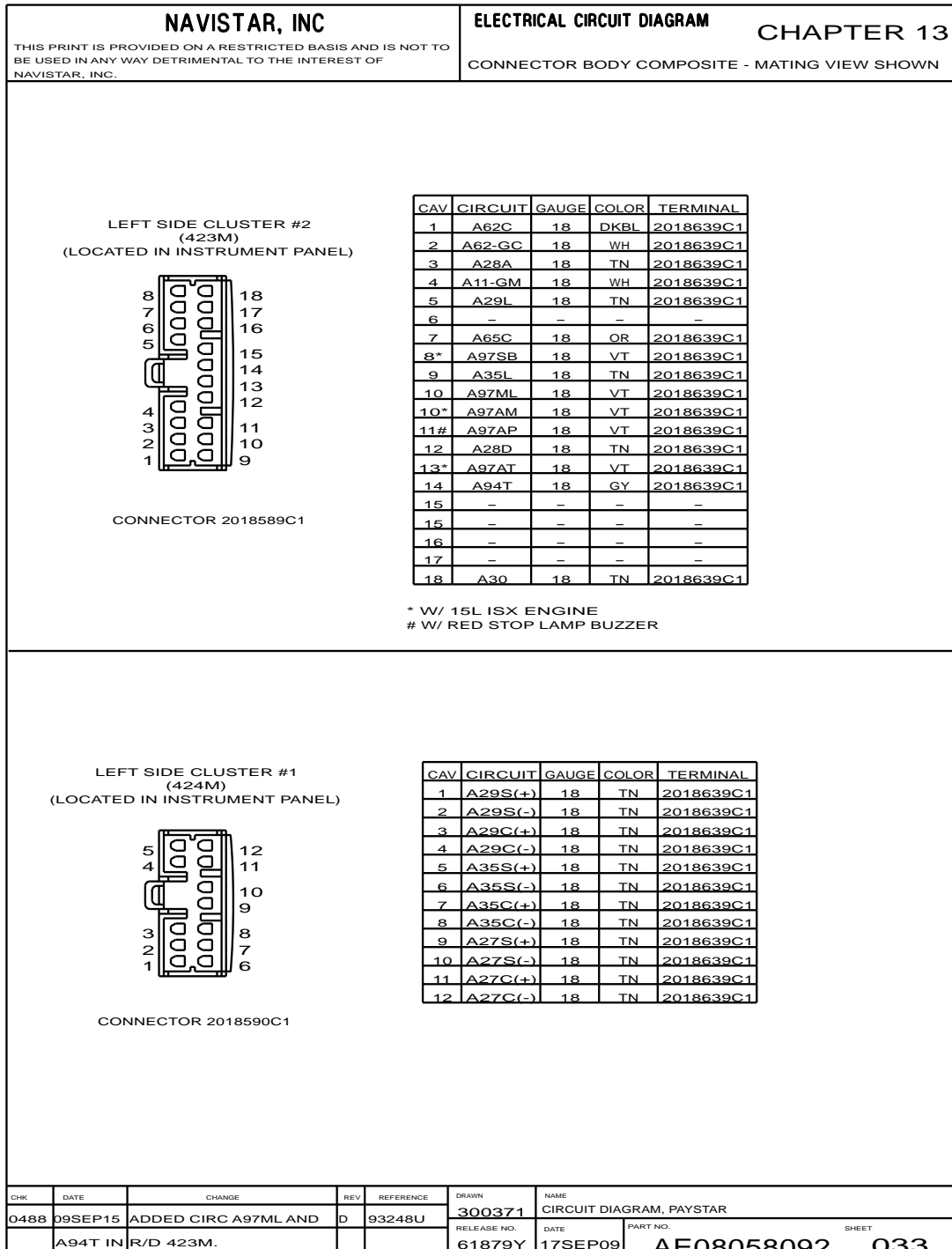


Figure 227 Connector Composites (423M / 424M)

13.41. CONNECTOR COMPOSITES (425M / 426 / 426M / 427 / 480F), P. 34

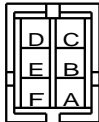
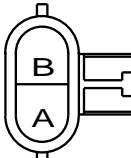
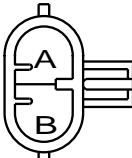
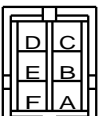
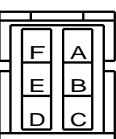
<b>NAVISTAR, INC</b>				<b>ELECTRICAL CIRCUIT DIAGRAM</b>				<b>CHAPTER 13</b>																																							
THIS PRINT IS PROVIDED ON A RESTRICTED BASIS AND IS NOT TO BE USED IN ANY WAY DETRIMENTAL TO THE INTEREST OF NAVISTAR, INC.				CONNECTOR BODY COMPOSITE - MATING VIEW SHOWN																																											
<p>PANEL LIGHT SWITCH (425M) (LOCATED IN INSTRUMENT PANEL)</p>  <p>CONNECTOR 1661200C1</p> <table border="1" style="margin-left: auto; margin-right: auto;"> <thead> <tr> <th>CAV</th><th>CIRCUIT</th><th>GAUGE</th><th>COLOR</th><th>TERMINAL</th></tr> </thead> <tbody> <tr><td>A</td><td>A62</td><td>16</td><td>DKBL</td><td>1661209C1</td></tr> <tr><td>B</td><td>A11-GS</td><td>16</td><td>WH</td><td>1661209C1</td></tr> <tr><td>C</td><td>A62A</td><td>16</td><td>DKBL</td><td>1661209C1</td></tr> <tr><td>D</td><td>A62W</td><td>16</td><td>DKBL</td><td>1661209C1</td></tr> <tr><td>E</td><td>-</td><td>-</td><td>-</td><td>-</td></tr> <tr><td>F</td><td>A62-GW</td><td>18</td><td>WH</td><td>1661208C1</td></tr> </tbody> </table>												CAV	CIRCUIT	GAUGE	COLOR	TERMINAL	A	A62	16	DKBL	1661209C1	B	A11-GS	16	WH	1661209C1	C	A62A	16	DKBL	1661209C1	D	A62W	16	DKBL	1661209C1	E	-	-	-	-	F	A62-GW	18	WH	1661208C1	
CAV	CIRCUIT	GAUGE	COLOR	TERMINAL																																											
A	A62	16	DKBL	1661209C1																																											
B	A11-GS	16	WH	1661209C1																																											
C	A62A	16	DKBL	1661209C1																																											
D	A62W	16	DKBL	1661209C1																																											
E	-	-	-	-																																											
F	A62-GW	18	WH	1661208C1																																											
<p>XMSN ECU (426 / 480F) (LOCATED IN CAB ROOF)</p>  <p>CONNECTOR 2031522C1 BODY LOCK 2033927C1</p>  <p>CONNECTOR 2031520C1 BODY LOCK 2033927C1</p> <table border="1" style="margin-left: auto; margin-right: auto;"> <thead> <tr> <th>CAV</th><th>CIRCUIT</th><th>GAUGE</th><th>COLOR</th><th>TERMINAL</th><th>SEAL/SLEEVE</th> <th>CAV</th><th>CIRCUIT</th><th>GAUGE</th><th>COLOR</th><th>TERMINAL</th><th>SEAL/SLEEVE</th> </tr> </thead> <tbody> <tr> <td>A</td><td>A14B</td><td>10</td><td>RD</td><td>2031531C1</td><td>2025427C1</td> <td>A</td><td>K92</td><td>14</td><td>TN</td><td>2025421C1</td><td>2025421C1</td> </tr> <tr> <td>B</td><td>A11-G</td><td>10</td><td>WH</td><td>2031531C1</td><td>2025427C1</td> <td>B</td><td>K92-G</td><td>14</td><td>TN</td><td>2025421C1</td><td>2025428C1</td> </tr> </tbody> </table>												CAV	CIRCUIT	GAUGE	COLOR	TERMINAL	SEAL/SLEEVE	CAV	CIRCUIT	GAUGE	COLOR	TERMINAL	SEAL/SLEEVE	A	A14B	10	RD	2031531C1	2025427C1	A	K92	14	TN	2025421C1	2025421C1	B	A11-G	10	WH	2031531C1	2025427C1	B	K92-G	14	TN	2025421C1	2025428C1
CAV	CIRCUIT	GAUGE	COLOR	TERMINAL	SEAL/SLEEVE	CAV	CIRCUIT	GAUGE	COLOR	TERMINAL	SEAL/SLEEVE																																				
A	A14B	10	RD	2031531C1	2025427C1	A	K92	14	TN	2025421C1	2025421C1																																				
B	A11-G	10	WH	2031531C1	2025427C1	B	K92-G	14	TN	2025421C1	2025428C1																																				
<p>RADIO #1 (426M)</p>  <p>CONNECTOR 1661200C1</p> <table border="1" style="margin-left: auto; margin-right: auto;"> <thead> <tr> <th>CAV</th><th>CIRCUIT</th><th>GAUGE</th><th>COLOR</th><th>TERMINAL</th></tr> </thead> <tbody> <tr><td>A</td><td>A88B</td><td>16</td><td>LTGN</td><td>1661209C1</td></tr> <tr><td>B</td><td>A86A</td><td>18</td><td>LTGN</td><td>1661208C1</td></tr> <tr><td>C</td><td>A86C</td><td>18</td><td>LTGN</td><td>1661208C1</td></tr> <tr><td>D@</td><td>A86</td><td>16</td><td>LTGN</td><td>1661209C1</td></tr> <tr><td>E</td><td>A86D</td><td>18</td><td>LTGN</td><td>1661208C1</td></tr> <tr><td>F</td><td>A86B</td><td>18</td><td>LTGN</td><td>1661208C1</td></tr> </tbody> </table> <p style="text-align: center;">@ W/500K BAUD RATE</p>												CAV	CIRCUIT	GAUGE	COLOR	TERMINAL	A	A88B	16	LTGN	1661209C1	B	A86A	18	LTGN	1661208C1	C	A86C	18	LTGN	1661208C1	D@	A86	16	LTGN	1661209C1	E	A86D	18	LTGN	1661208C1	F	A86B	18	LTGN	1661208C1	
CAV	CIRCUIT	GAUGE	COLOR	TERMINAL																																											
A	A88B	16	LTGN	1661209C1																																											
B	A86A	18	LTGN	1661208C1																																											
C	A86C	18	LTGN	1661208C1																																											
D@	A86	16	LTGN	1661209C1																																											
E	A86D	18	LTGN	1661208C1																																											
F	A86B	18	LTGN	1661208C1																																											
<p>RADIO #2 (427) (LOCATED IN CAB ROOF)</p>  <p>CONNECTOR 1661201C1</p> <table border="1" style="margin-left: auto; margin-right: auto;"> <thead> <tr> <th>CAV</th><th>CIRCUIT</th><th>GAUGE</th><th>COLOR</th><th>TERMINAL</th></tr> </thead> <tbody> <tr><td>A</td><td>A86-GA</td><td>18</td><td>WH</td><td>1661212C1</td></tr> <tr><td>B</td><td>A86N</td><td>18</td><td>LTGN</td><td>1661212C1</td></tr> <tr><td>C</td><td>A86V</td><td>18</td><td>LTGN</td><td>1661212C1</td></tr> <tr><td>D</td><td>A86W</td><td>18</td><td>LTGN</td><td>1661212C1</td></tr> <tr><td>E</td><td>A86P</td><td>18</td><td>LTGN</td><td>1661212C1</td></tr> <tr><td>F</td><td>-</td><td>-</td><td>-</td><td>-</td></tr> </tbody> </table>												CAV	CIRCUIT	GAUGE	COLOR	TERMINAL	A	A86-GA	18	WH	1661212C1	B	A86N	18	LTGN	1661212C1	C	A86V	18	LTGN	1661212C1	D	A86W	18	LTGN	1661212C1	E	A86P	18	LTGN	1661212C1	F	-	-	-	-	
CAV	CIRCUIT	GAUGE	COLOR	TERMINAL																																											
A	A86-GA	18	WH	1661212C1																																											
B	A86N	18	LTGN	1661212C1																																											
C	A86V	18	LTGN	1661212C1																																											
D	A86W	18	LTGN	1661212C1																																											
E	A86P	18	LTGN	1661212C1																																											
F	-	-	-	-																																											
CHK	DATE	CHANGE	REV	REFERENCE	DRAWN	NAME																																									
MJVO	13MAR16	ADDED CIRC A86 AT CAV	B	93408S	300371	CIRCUIT DIAGRAM, PAYSTAR																																									
					RELEASE NO.	DATE	PART NO.	SHEET																																							
					61879Y	17SEP09	AE08058092	034																																							

Figure 228 Connector Composites (425M / 426 / 426M / 427 / 480F)

13.42. CONNECTOR COMPOSITES (428F / 429F / 430), P. 35

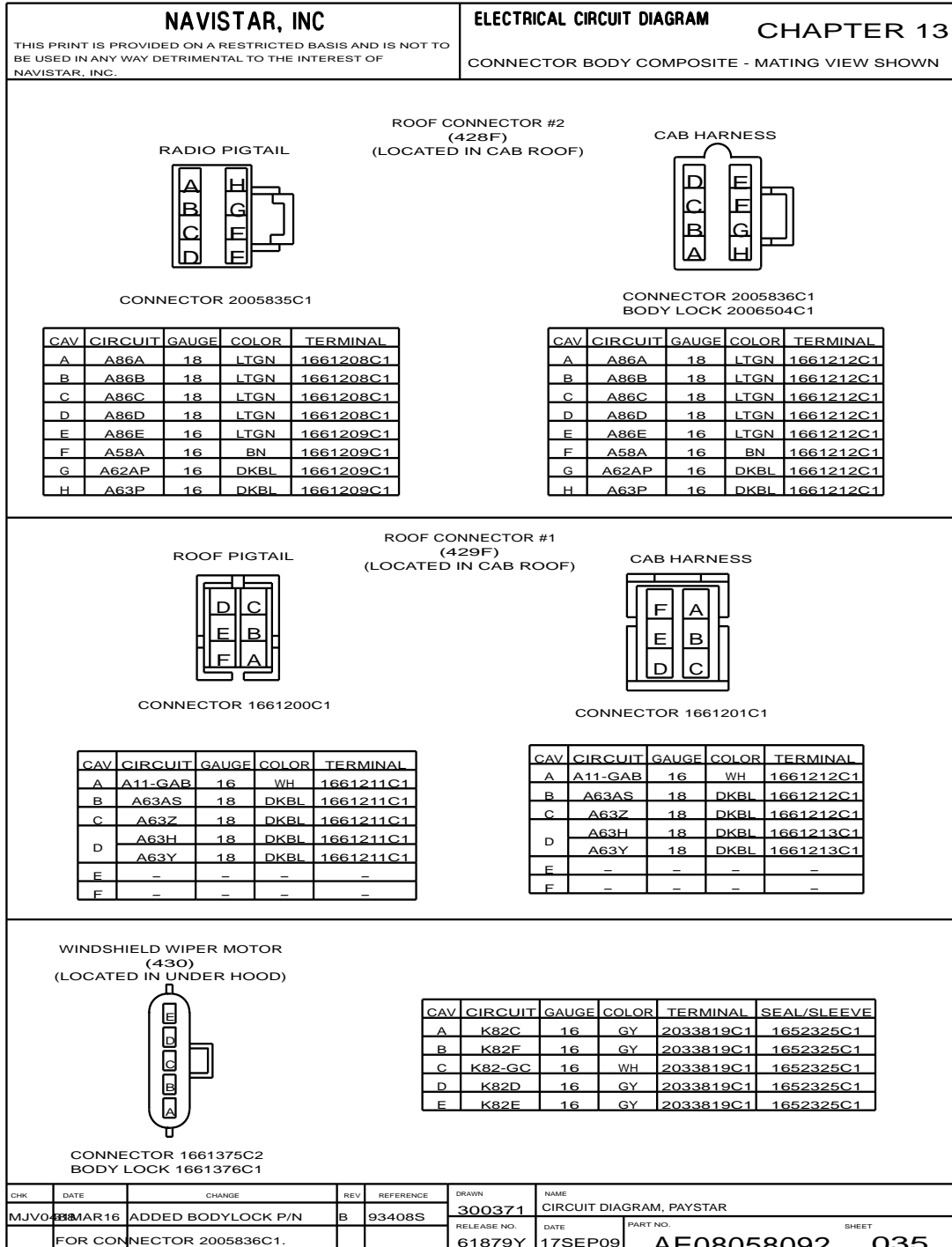


Figure 229 Connector Composites (428F / 429F / 430)

13.43. CONNECTOR COMPOSITES (433M / 434M / 435M), P. 36

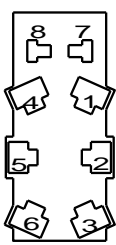
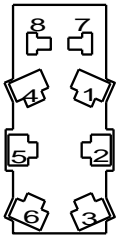
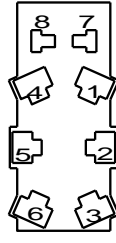
<b>NAVISTAR, INC</b> <small>THIS PRINT IS PROVIDED ON A RESTRICTED BASIS AND IS NOT TO BE USED IN ANY WAY DETRIMENTAL TO THE INTEREST OF NAVISTAR, INC.</small>				ELECTRICAL CIRCUIT DIAGRAM <b>CHAPTER 13</b> CONNECTOR BODY COMPOSITE - MATING VIEW SHOWN																																																								
<div style="display: flex; justify-content: space-between;"> <div style="width: 45%;"> <p><b>ENGINE BRAKE SELECTOR SWITCH (433M)</b></p>  <p style="text-align: center;">CONNECTOR 2009385C1</p> </div> <div style="width: 50%;"> <table border="1" style="width:100%; border-collapse: collapse; font-size: 8px;"> <thead> <tr> <th>CAV</th> <th>CIRCUIT</th> <th>GAUGE</th> <th>COLOR</th> <th>TERMINAL</th> </tr> </thead> <tbody> <tr><td>1</td><td>-</td><td>-</td><td>-</td><td>-</td></tr> <tr><td>2#</td><td>A24AD</td><td>18</td><td>GY</td><td>1661224C1</td></tr> <tr><td>2*</td><td>A24BL</td><td>16</td><td>GY</td><td>1661226C1</td></tr> <tr><td>3</td><td>A24AE</td><td>18</td><td>GY</td><td>1661224C1</td></tr> <tr><td>4</td><td>-</td><td>-</td><td>-</td><td>-</td></tr> <tr><td>5</td><td>-</td><td>-</td><td>-</td><td>-</td></tr> <tr><td>6</td><td>A24AF</td><td>18</td><td>GY</td><td>1661224C1</td></tr> <tr><td>7</td><td>A62L</td><td>16</td><td>DKBL</td><td>1661209C1</td></tr> <tr><td>8</td><td>A62-GL</td><td>18</td><td>WH</td><td>1661208C1</td></tr> </tbody> </table> <p style="text-align: center; font-size: 8px;">* W/ ENGINE BRAKE # N/ ENGINE BRAKE</p> </div> </div>						CAV	CIRCUIT	GAUGE	COLOR	TERMINAL	1	-	-	-	-	2#	A24AD	18	GY	1661224C1	2*	A24BL	16	GY	1661226C1	3	A24AE	18	GY	1661224C1	4	-	-	-	-	5	-	-	-	-	6	A24AF	18	GY	1661224C1	7	A62L	16	DKBL	1661209C1	8	A62-GL	18	WH	1661208C1					
CAV	CIRCUIT	GAUGE	COLOR	TERMINAL																																																								
1	-	-	-	-																																																								
2#	A24AD	18	GY	1661224C1																																																								
2*	A24BL	16	GY	1661226C1																																																								
3	A24AE	18	GY	1661224C1																																																								
4	-	-	-	-																																																								
5	-	-	-	-																																																								
6	A24AF	18	GY	1661224C1																																																								
7	A62L	16	DKBL	1661209C1																																																								
8	A62-GL	18	WH	1661208C1																																																								
<div style="display: flex; justify-content: space-between;"> <div style="width: 45%;"> <p><b>ENGINE BRAKE ON / OFF SWITCH (434M)</b></p>  <p style="text-align: center;">CONNECTOR 2009385C1</p> </div> <div style="width: 50%;"> <table border="1" style="width:100%; border-collapse: collapse; font-size: 8px;"> <thead> <tr> <th>CAV</th> <th>CIRCUIT</th> <th>GAUGE</th> <th>COLOR</th> <th>TERMINAL</th> </tr> </thead> <tbody> <tr><td>1</td><td>-</td><td>-</td><td>-</td><td>-</td></tr> <tr><td>2</td><td>A24AM</td><td>18</td><td>GY</td><td>1661224C1</td></tr> <tr><td>3</td><td>A24CL</td><td>16</td><td>GY</td><td>1661226C1</td></tr> <tr><td>4</td><td>-</td><td>-</td><td>-</td><td>-</td></tr> <tr><td>5#</td><td>A24AD</td><td>18</td><td>GY</td><td>1661224C1</td></tr> <tr><td>5*</td><td>A24BD</td><td>16</td><td>GY</td><td>1661226C1</td></tr> <tr><td>6#</td><td>A24AM</td><td>18</td><td>GY</td><td>1661224C1</td></tr> <tr><td>6*</td><td>A92-GT</td><td>18</td><td>TN</td><td>1661224C1</td></tr> <tr><td>7</td><td>A62N</td><td>16</td><td>DKBL</td><td>1661209C1</td></tr> <tr><td>8</td><td>A62-GN</td><td>18</td><td>WH</td><td>1661208C1</td></tr> </tbody> </table> </div> </div>						CAV	CIRCUIT	GAUGE	COLOR	TERMINAL	1	-	-	-	-	2	A24AM	18	GY	1661224C1	3	A24CL	16	GY	1661226C1	4	-	-	-	-	5#	A24AD	18	GY	1661224C1	5*	A24BD	16	GY	1661226C1	6#	A24AM	18	GY	1661224C1	6*	A92-GT	18	TN	1661224C1	7	A62N	16	DKBL	1661209C1	8	A62-GN	18	WH	1661208C1
CAV	CIRCUIT	GAUGE	COLOR	TERMINAL																																																								
1	-	-	-	-																																																								
2	A24AM	18	GY	1661224C1																																																								
3	A24CL	16	GY	1661226C1																																																								
4	-	-	-	-																																																								
5#	A24AD	18	GY	1661224C1																																																								
5*	A24BD	16	GY	1661226C1																																																								
6#	A24AM	18	GY	1661224C1																																																								
6*	A92-GT	18	TN	1661224C1																																																								
7	A62N	16	DKBL	1661209C1																																																								
8	A62-GN	18	WH	1661208C1																																																								
<div style="display: flex; justify-content: space-between;"> <div style="width: 45%;"> <p><b>CRUISE ON / OFF SWITCH (435M)</b></p>  <p style="text-align: center;">CONNECTOR 2009385C1</p> </div> <div style="width: 50%;"> <table border="1" style="width:100%; border-collapse: collapse; font-size: 8px;"> <thead> <tr> <th>CAV</th> <th>CIRCUIT</th> <th>GAUGE</th> <th>COLOR</th> <th>TERMINAL</th> </tr> </thead> <tbody> <tr><td>1</td><td>-</td><td>-</td><td>-</td><td>-</td></tr> <tr><td>2</td><td>-</td><td>-</td><td>-</td><td>-</td></tr> <tr><td>3</td><td>-</td><td>-</td><td>-</td><td>-</td></tr> <tr><td>4</td><td>-</td><td>-</td><td>-</td><td>-</td></tr> <tr><td>5</td><td>A97AE</td><td>18</td><td>VT</td><td>1661224C1</td></tr> <tr><td rowspan="2">6</td><td>A97CR</td><td>18</td><td>VT</td><td>3541250C1</td></tr> <tr><td>A97CS</td><td>18</td><td>VT</td><td></td></tr> <tr><td>6*</td><td>A97GC</td><td>18</td><td>VT</td><td>1661224C1</td></tr> <tr><td>7</td><td>A62J</td><td>16</td><td>DKBL</td><td>1661209C1</td></tr> <tr><td>8</td><td>A62-GJ</td><td>18</td><td>WH</td><td>1661208C1</td></tr> </tbody> </table> <p style="text-align: center; font-size: 8px;">* W/ 15L ISX ENGINE</p> </div> </div>						CAV	CIRCUIT	GAUGE	COLOR	TERMINAL	1	-	-	-	-	2	-	-	-	-	3	-	-	-	-	4	-	-	-	-	5	A97AE	18	VT	1661224C1	6	A97CR	18	VT	3541250C1	A97CS	18	VT		6*	A97GC	18	VT	1661224C1	7	A62J	16	DKBL	1661209C1	8	A62-GJ	18	WH	1661208C1	
CAV	CIRCUIT	GAUGE	COLOR	TERMINAL																																																								
1	-	-	-	-																																																								
2	-	-	-	-																																																								
3	-	-	-	-																																																								
4	-	-	-	-																																																								
5	A97AE	18	VT	1661224C1																																																								
6	A97CR	18	VT	3541250C1																																																								
	A97CS	18	VT																																																									
6*	A97GC	18	VT	1661224C1																																																								
7	A62J	16	DKBL	1661209C1																																																								
8	A62-GJ	18	WH	1661208C1																																																								
CHK	DATE	CHANGE	REV	REFERENCE	DRAWN	NAME																																																						
012	17APR13	ADDED CIRC: A97GC	B	91786V	300371	CIRCUIT DIAGRAM, PAYSTAR																																																						
IN R/D 435M.				RELEASE NO.	DATE	PART NO.																																																						
				61879Y	17SEP09	AE08058092																																																						
					SHEET	036																																																						

Figure 230 Connector Composites (433M / 434M / 435M)



13.44. CONNECTOR COMPOSITES (436M / 437M / 438M / 440M), P. 37

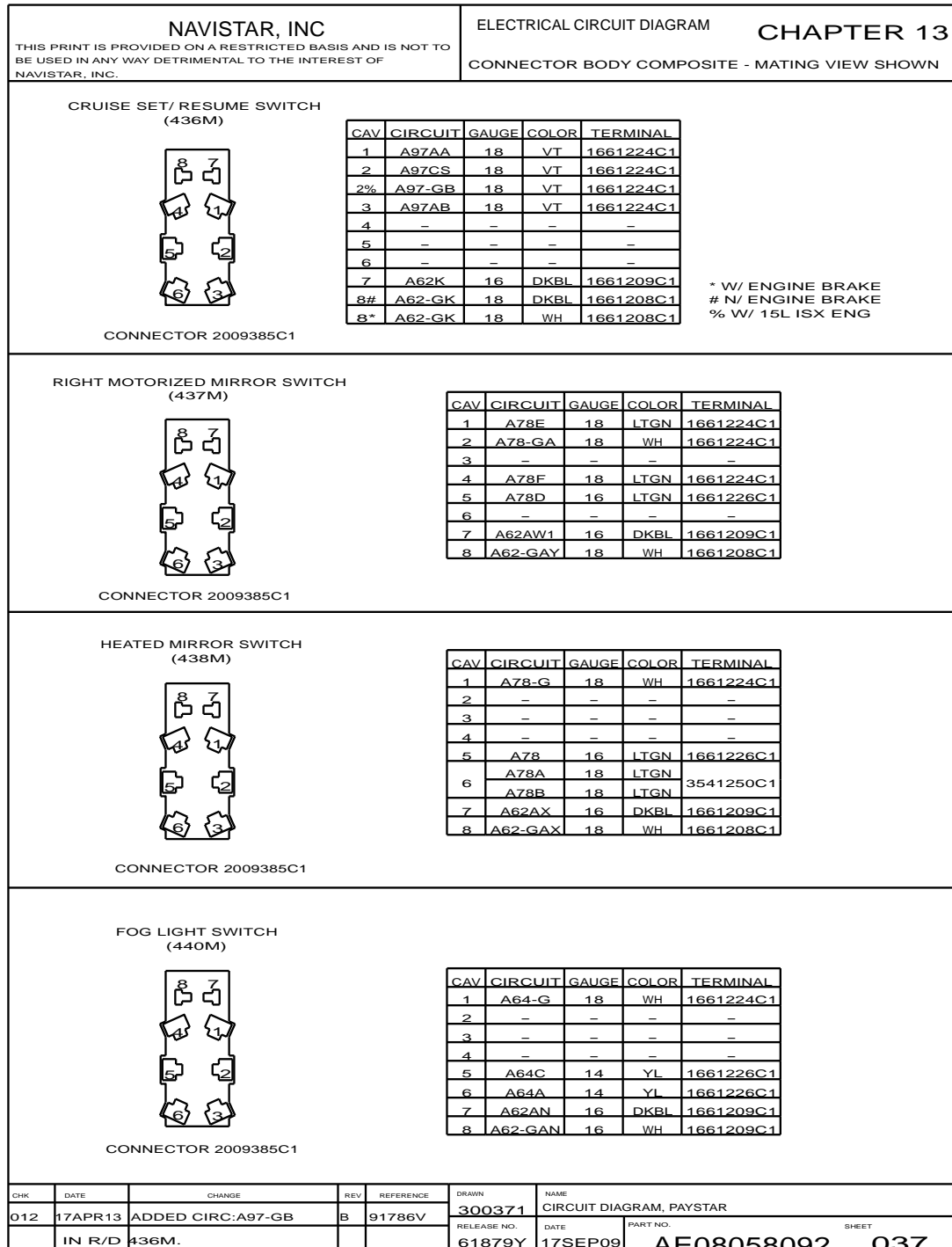


Figure 231 Connector Composites (436M / 437M / 438M / 440M)

13.45. CONNECTOR COMPOSITES (441 / 442 / 453M), P. 38

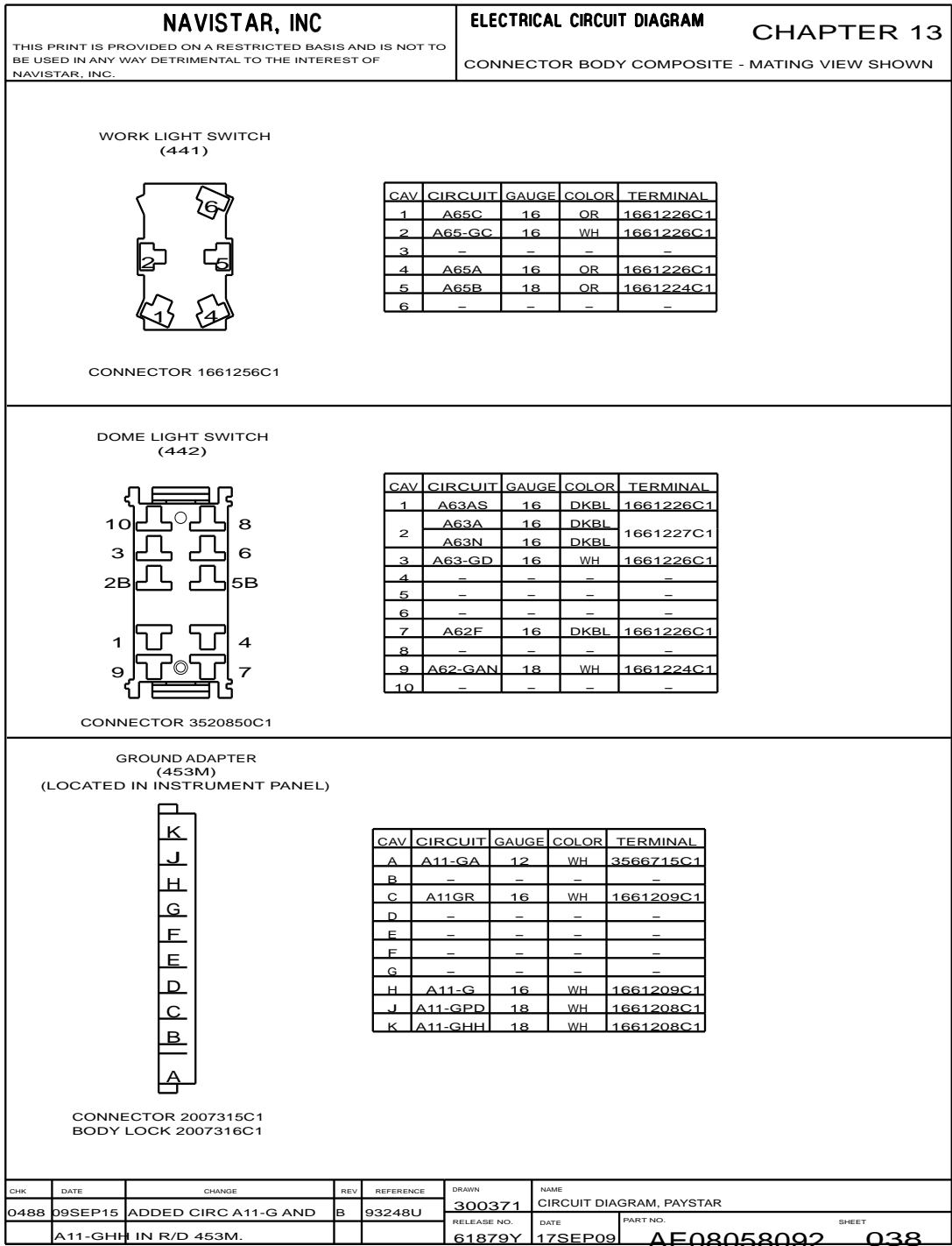


Figure 232 Connector Composites (441 / 442 / 453M)

13.46. CONNECTOR COMPOSITES (454M / 455M), P. 39

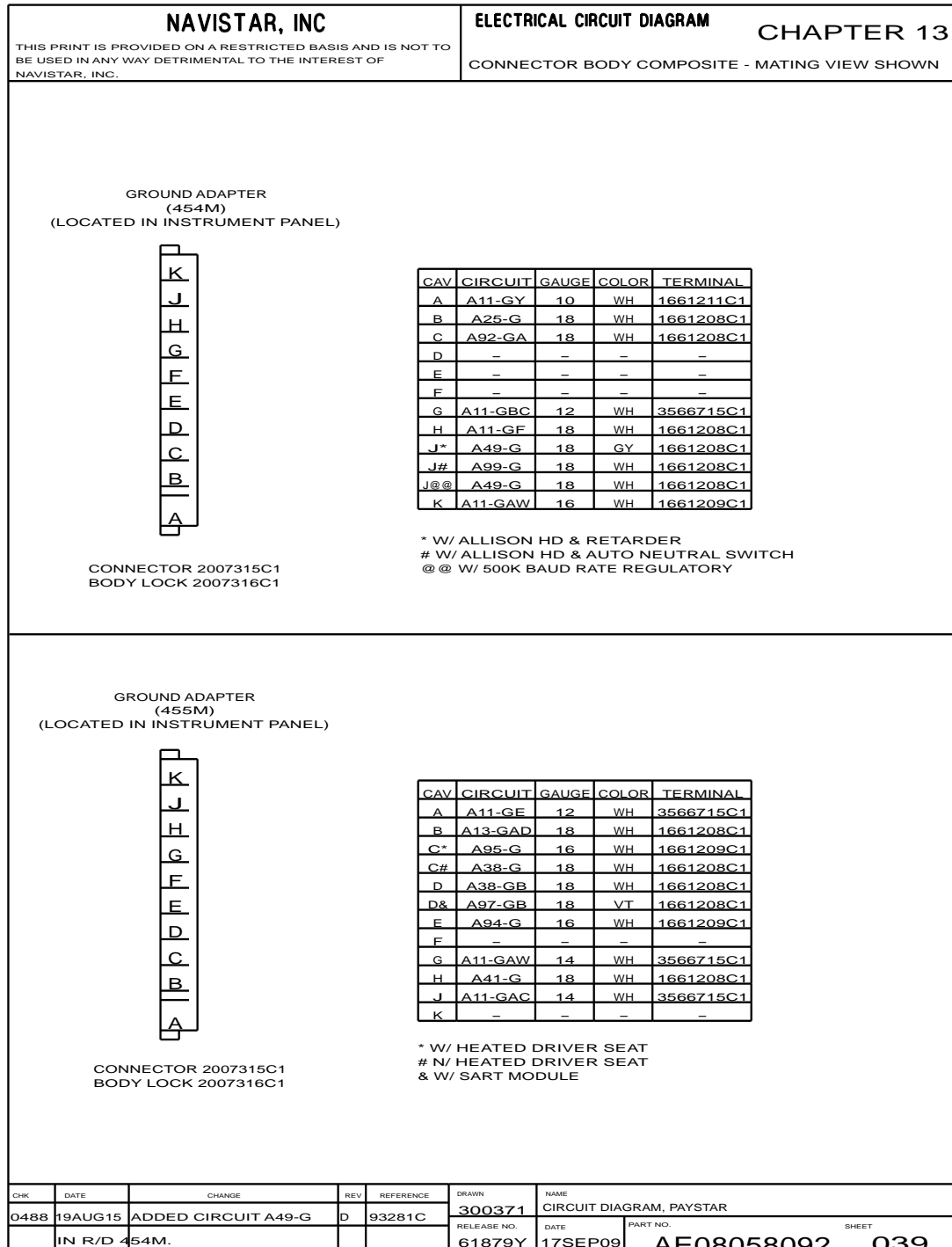


Figure 233 Connector Composites (454M / 455M)

13.47. CONNECTOR COMPOSITES (456M / 457M / 460F), P. 40

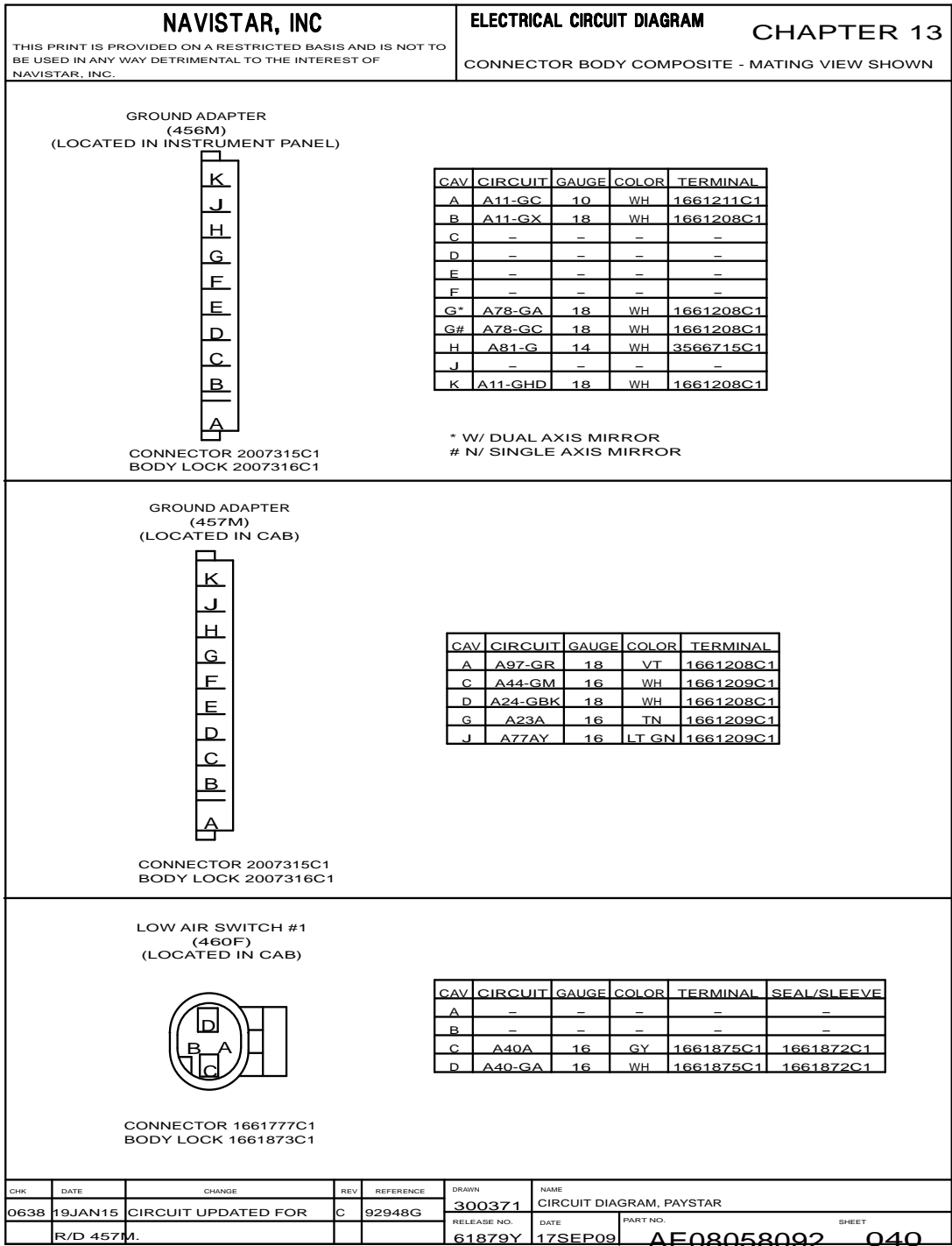


Figure 234 Connector Composites (456M / 457M / 460F)

13.48. CONNECTOR COMPOSITES (462M), P. 41

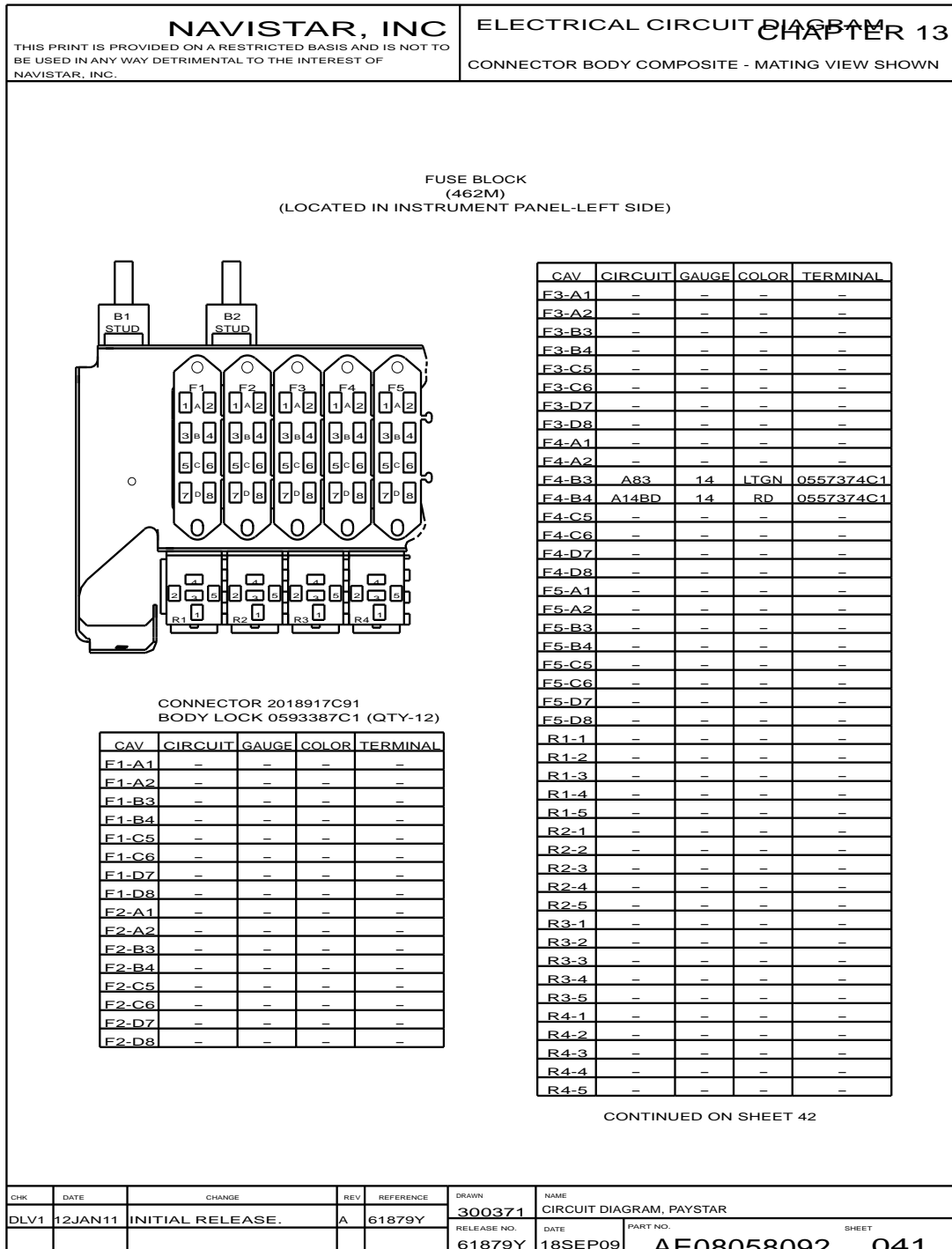


Figure 235 Connector Composites (462M)

13.49. CONNECTOR COMPOSITES (462M), P. 42

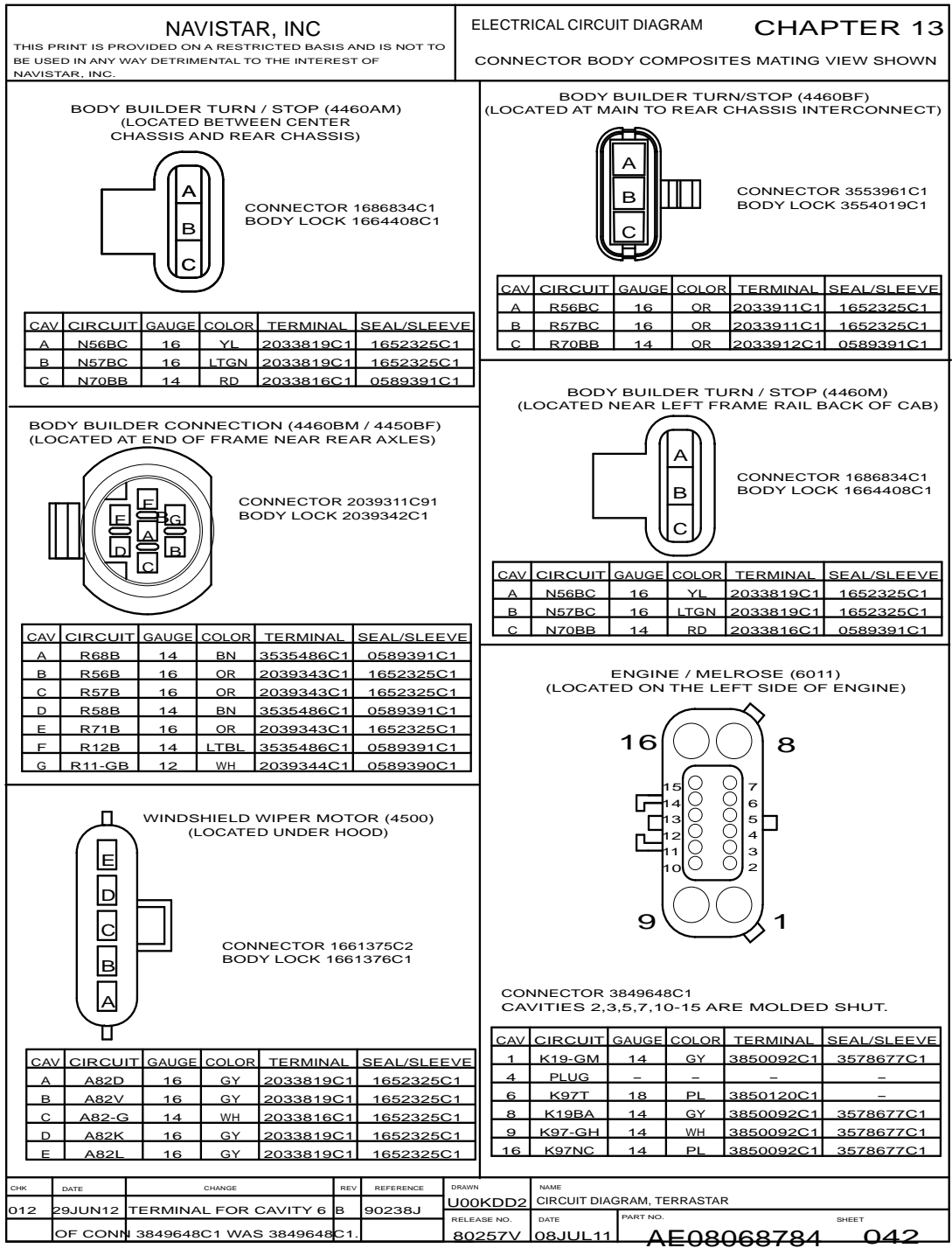


Figure 236 Connector Composites (462M)

13.50. CONNECTOR COMPOSITES (462M), P. 43

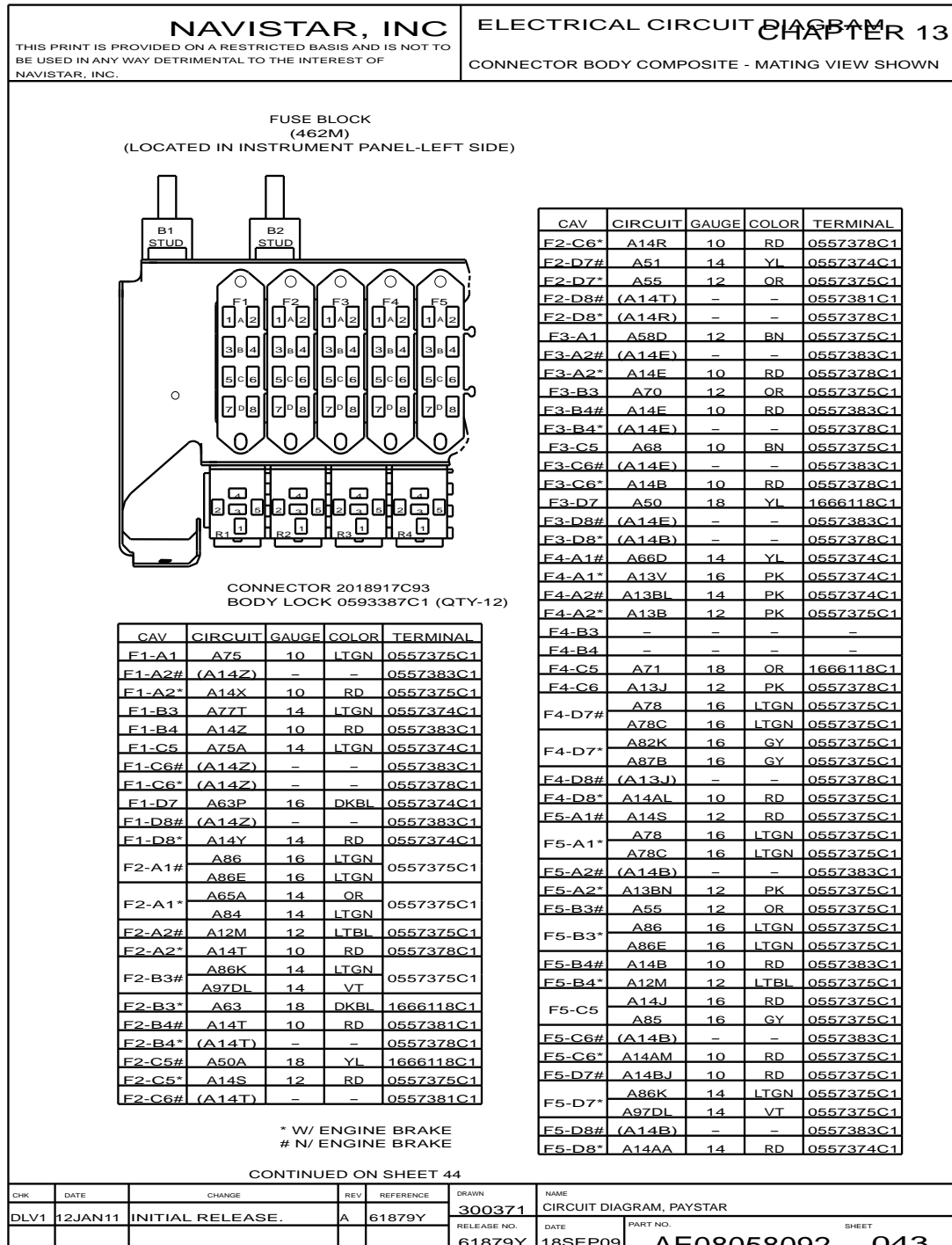


Figure 237 Connector Composites (462M)

13.51. CONNECTOR COMPOSITES (462M), P. 44

<b>NAVISTAR, INC</b>				<b>ELECTRICAL CIRCUIT DIAGRAM CHAPTER 13</b>																																																																																																																														
THIS PRINT IS PROVIDED ON A RESTRICTED BASIS AND IS NOT TO BE USED IN ANY WAY DETRIMENTAL TO THE INTEREST OF NAVISTAR, INC.				CONNECTOR BODY COMPOSITE - MATING VIEW SHOWN																																																																																																																														
<table border="1" style="width: 100%; border-collapse: collapse; margin: 10px 0;"> <thead> <tr> <th>CAV</th> <th>CIRCUIT</th> <th>GAUGE</th> <th>COLOR</th> <th>TERMINAL</th> </tr> </thead> <tbody> <tr><td>R1-1</td><td>A14S</td><td>12</td><td>RD</td><td>1661710C1</td></tr> <tr><td>R1-2</td><td>A13-GA</td><td>18</td><td>WH</td><td>1659673C1</td></tr> <tr><td>R1-3</td><td>-</td><td>-</td><td>-</td><td>-</td></tr> <tr><td>R1-4</td><td>A13H</td><td>12</td><td>PK</td><td>1661710C1</td></tr> <tr><td>R1-5</td><td>A13A</td><td>12</td><td>PK</td><td>1661710C1</td></tr> <tr><td>R2-1</td><td>A75F</td><td>10</td><td>LTGN</td><td>1661710C1</td></tr> <tr><td>R2-2&amp;</td><td>A13-GA</td><td>18</td><td>WH</td><td>1661709C1</td></tr> <tr><td>R2-2&amp;</td><td>A75-GB</td><td>18</td><td>WH</td><td>1661709C1</td></tr> <tr><td>R2-3</td><td>A75T</td><td>14</td><td>LTGN</td><td>1661709C1</td></tr> <tr><td>R2-4</td><td>A75</td><td>10</td><td>LTGN</td><td>1661710C1</td></tr> <tr><td>R2-5</td><td>A75H</td><td>14</td><td>LTGN</td><td>1661709C1</td></tr> <tr><td>R3-1</td><td>A75D</td><td>14</td><td>LTGN</td><td>1661709C1</td></tr> <tr><td>R3-2&amp;</td><td>A75-GB</td><td>18</td><td>WH</td><td>1661709C1</td></tr> <tr><td>R3-2&amp;</td><td>A75-GC</td><td>18</td><td>WH</td><td>1661709C1</td></tr> <tr><td>R3-3</td><td>-</td><td>-</td><td>-</td><td>-</td></tr> <tr><td>R3-4</td><td>A75M</td><td>14</td><td>LTGN</td><td>1661709C1</td></tr> <tr><td>R3-5</td><td>A75N</td><td>14</td><td>LTGN</td><td>1661709C1</td></tr> <tr><td>R4-1</td><td>A51</td><td>14</td><td>YL</td><td>1661709C1</td></tr> <tr><td>R4-2&amp;</td><td>A50-GB</td><td>18</td><td>WH</td><td>1661709C1</td></tr> <tr><td>R4-2&amp;</td><td>A75-GC</td><td>18</td><td>WH</td><td>1661709C1</td></tr> <tr><td>R4-3</td><td>-</td><td>-</td><td>-</td><td>-</td></tr> <tr><td>R4-4</td><td>A51A</td><td>14</td><td>YL</td><td>1661709C1</td></tr> <tr><td>R4-5&amp;</td><td>A50B</td><td>18</td><td>YL</td><td>1661709C1</td></tr> <tr><td>R4-5&amp;</td><td>A66H</td><td>18</td><td>YL</td><td>1661709C1</td></tr> </tbody> </table>						CAV	CIRCUIT	GAUGE	COLOR	TERMINAL	R1-1	A14S	12	RD	1661710C1	R1-2	A13-GA	18	WH	1659673C1	R1-3	-	-	-	-	R1-4	A13H	12	PK	1661710C1	R1-5	A13A	12	PK	1661710C1	R2-1	A75F	10	LTGN	1661710C1	R2-2&	A13-GA	18	WH	1661709C1	R2-2&	A75-GB	18	WH	1661709C1	R2-3	A75T	14	LTGN	1661709C1	R2-4	A75	10	LTGN	1661710C1	R2-5	A75H	14	LTGN	1661709C1	R3-1	A75D	14	LTGN	1661709C1	R3-2&	A75-GB	18	WH	1661709C1	R3-2&	A75-GC	18	WH	1661709C1	R3-3	-	-	-	-	R3-4	A75M	14	LTGN	1661709C1	R3-5	A75N	14	LTGN	1661709C1	R4-1	A51	14	YL	1661709C1	R4-2&	A50-GB	18	WH	1661709C1	R4-2&	A75-GC	18	WH	1661709C1	R4-3	-	-	-	-	R4-4	A51A	14	YL	1661709C1	R4-5&	A50B	18	YL	1661709C1	R4-5&	A66H	18	YL	1661709C1
CAV	CIRCUIT	GAUGE	COLOR	TERMINAL																																																																																																																														
R1-1	A14S	12	RD	1661710C1																																																																																																																														
R1-2	A13-GA	18	WH	1659673C1																																																																																																																														
R1-3	-	-	-	-																																																																																																																														
R1-4	A13H	12	PK	1661710C1																																																																																																																														
R1-5	A13A	12	PK	1661710C1																																																																																																																														
R2-1	A75F	10	LTGN	1661710C1																																																																																																																														
R2-2&	A13-GA	18	WH	1661709C1																																																																																																																														
R2-2&	A75-GB	18	WH	1661709C1																																																																																																																														
R2-3	A75T	14	LTGN	1661709C1																																																																																																																														
R2-4	A75	10	LTGN	1661710C1																																																																																																																														
R2-5	A75H	14	LTGN	1661709C1																																																																																																																														
R3-1	A75D	14	LTGN	1661709C1																																																																																																																														
R3-2&	A75-GB	18	WH	1661709C1																																																																																																																														
R3-2&	A75-GC	18	WH	1661709C1																																																																																																																														
R3-3	-	-	-	-																																																																																																																														
R3-4	A75M	14	LTGN	1661709C1																																																																																																																														
R3-5	A75N	14	LTGN	1661709C1																																																																																																																														
R4-1	A51	14	YL	1661709C1																																																																																																																														
R4-2&	A50-GB	18	WH	1661709C1																																																																																																																														
R4-2&	A75-GC	18	WH	1661709C1																																																																																																																														
R4-3	-	-	-	-																																																																																																																														
R4-4	A51A	14	YL	1661709C1																																																																																																																														
R4-5&	A50B	18	YL	1661709C1																																																																																																																														
R4-5&	A66H	18	YL	1661709C1																																																																																																																														
& MUTUAL EXCLUSIVE																																																																																																																																		
<table border="1" style="width: 100%; border-collapse: collapse; margin: 10px 0;"> <thead> <tr> <th>FUSE LOCATION</th> <th>CAVITY</th> <th>RATING IN AMP</th> <th>PART NUMBER</th> <th>DESCRIPTION</th> </tr> </thead> <tbody> <tr> <td></td> <td></td> <td></td> <td>FUSE</td> <td>BREAKER</td> </tr> <tr><td>F1-A</td><td>1-2</td><td>30</td><td>0571691C1</td><td>-</td></tr> <tr><td>F1-B</td><td>3-4</td><td>10</td><td>0131222C1</td><td>-</td></tr> <tr><td>F1-C</td><td>5-6</td><td>20</td><td>0131224C1</td><td>-</td></tr> <tr><td>F1-D</td><td>7-8</td><td>15</td><td>0509080C1</td><td>-</td></tr> <tr><td>F2-A</td><td>1-2</td><td>15</td><td>0509080C1</td><td>-</td></tr> <tr><td>F2-B</td><td>3-4</td><td>20</td><td>0131224C1</td><td>-</td></tr> <tr><td>F2-C</td><td>5-6</td><td>10</td><td>-</td><td>2007463C1</td></tr> <tr><td>F2-D</td><td>7-8</td><td>25</td><td>-</td><td>2007466C1</td></tr> <tr><td>F3-A</td><td>1-2</td><td>20</td><td>0131224C1</td><td>-</td></tr> <tr><td>F3-B</td><td>3-4</td><td>20</td><td>0131224C1</td><td>-</td></tr> <tr><td>F3-C</td><td>5-6</td><td>30</td><td>0571691C1</td><td>-</td></tr> <tr><td>F3-D</td><td>7-8</td><td>10</td><td>0131222C1</td><td>-</td></tr> <tr><td>F4-A</td><td>1-2</td><td>10</td><td>0131222C1</td><td>-</td></tr> <tr><td>F4-B</td><td>3-4</td><td>-</td><td>-</td><td>-</td></tr> <tr><td>F4-C</td><td>5-6</td><td>10</td><td>0131222C1</td><td>-</td></tr> <tr><td>F4-D</td><td>7-8</td><td>15</td><td>0509080C1</td><td>-</td></tr> <tr><td>F5-A</td><td>1-2</td><td>30</td><td>0571691C1</td><td>-</td></tr> <tr><td>F5-B</td><td>3-4</td><td>20</td><td>0131224C1</td><td>-</td></tr> <tr><td>F5-C</td><td>5-6</td><td>15</td><td>0509080C1</td><td>-</td></tr> <tr><td>F5-D</td><td>7-8</td><td>30</td><td>0571691C1</td><td>-</td></tr> </tbody> </table>						FUSE LOCATION	CAVITY	RATING IN AMP	PART NUMBER	DESCRIPTION				FUSE	BREAKER	F1-A	1-2	30	0571691C1	-	F1-B	3-4	10	0131222C1	-	F1-C	5-6	20	0131224C1	-	F1-D	7-8	15	0509080C1	-	F2-A	1-2	15	0509080C1	-	F2-B	3-4	20	0131224C1	-	F2-C	5-6	10	-	2007463C1	F2-D	7-8	25	-	2007466C1	F3-A	1-2	20	0131224C1	-	F3-B	3-4	20	0131224C1	-	F3-C	5-6	30	0571691C1	-	F3-D	7-8	10	0131222C1	-	F4-A	1-2	10	0131222C1	-	F4-B	3-4	-	-	-	F4-C	5-6	10	0131222C1	-	F4-D	7-8	15	0509080C1	-	F5-A	1-2	30	0571691C1	-	F5-B	3-4	20	0131224C1	-	F5-C	5-6	15	0509080C1	-	F5-D	7-8	30	0571691C1	-															
FUSE LOCATION	CAVITY	RATING IN AMP	PART NUMBER	DESCRIPTION																																																																																																																														
			FUSE	BREAKER																																																																																																																														
F1-A	1-2	30	0571691C1	-																																																																																																																														
F1-B	3-4	10	0131222C1	-																																																																																																																														
F1-C	5-6	20	0131224C1	-																																																																																																																														
F1-D	7-8	15	0509080C1	-																																																																																																																														
F2-A	1-2	15	0509080C1	-																																																																																																																														
F2-B	3-4	20	0131224C1	-																																																																																																																														
F2-C	5-6	10	-	2007463C1																																																																																																																														
F2-D	7-8	25	-	2007466C1																																																																																																																														
F3-A	1-2	20	0131224C1	-																																																																																																																														
F3-B	3-4	20	0131224C1	-																																																																																																																														
F3-C	5-6	30	0571691C1	-																																																																																																																														
F3-D	7-8	10	0131222C1	-																																																																																																																														
F4-A	1-2	10	0131222C1	-																																																																																																																														
F4-B	3-4	-	-	-																																																																																																																														
F4-C	5-6	10	0131222C1	-																																																																																																																														
F4-D	7-8	15	0509080C1	-																																																																																																																														
F5-A	1-2	30	0571691C1	-																																																																																																																														
F5-B	3-4	20	0131224C1	-																																																																																																																														
F5-C	5-6	15	0509080C1	-																																																																																																																														
F5-D	7-8	30	0571691C1	-																																																																																																																														
<table border="1" style="width: 100%; border-collapse: collapse; margin: 10px 0;"> <thead> <tr> <th>RELAY LOCATION</th> <th>CAVITY</th> <th>PART NUMBER</th> <th>DESCRIPTION</th> </tr> </thead> <tbody> <tr><td>R1</td><td>1, 2, 3, 4, 5</td><td>2012557C1</td><td>IGNITION RELAY</td></tr> <tr><td>R2</td><td>1, 2, 3, 4, 5</td><td>2012557C1</td><td>HIGH SPEED RELAY</td></tr> <tr><td>R3</td><td>1, 2, 3, 4, 5</td><td>2012557C1</td><td>MEDIUM HIGH SPEED RELAY</td></tr> <tr><td>R4</td><td>1, 2, 3, 4, 5</td><td>2012557C1</td><td>HEADLIGHT RELAY</td></tr> </tbody> </table>						RELAY LOCATION	CAVITY	PART NUMBER	DESCRIPTION	R1	1, 2, 3, 4, 5	2012557C1	IGNITION RELAY	R2	1, 2, 3, 4, 5	2012557C1	HIGH SPEED RELAY	R3	1, 2, 3, 4, 5	2012557C1	MEDIUM HIGH SPEED RELAY	R4	1, 2, 3, 4, 5	2012557C1	HEADLIGHT RELAY																																																																																																									
RELAY LOCATION	CAVITY	PART NUMBER	DESCRIPTION																																																																																																																															
R1	1, 2, 3, 4, 5	2012557C1	IGNITION RELAY																																																																																																																															
R2	1, 2, 3, 4, 5	2012557C1	HIGH SPEED RELAY																																																																																																																															
R3	1, 2, 3, 4, 5	2012557C1	MEDIUM HIGH SPEED RELAY																																																																																																																															
R4	1, 2, 3, 4, 5	2012557C1	HEADLIGHT RELAY																																																																																																																															
CONTINUED FROM SHEET 43																																																																																																																																		
CHK	DATE	CHANGE	REV	REFERENCE	DRAWN	NAME																																																																																																																												
DLV1	12JAN11	INITIAL RELEASE.	A	61879Y	300371	CIRCUIT DIAGRAM, PAYSTAR																																																																																																																												
					RELEASE NO.	DATE																																																																																																																												
					61879Y	18SEP09																																																																																																																												
					PART NO.	SHEET																																																																																																																												
					AE08058092	044																																																																																																																												

Figure 238 Connector Composites (462M)



13.52. CONNECTOR COMPOSITES (463M), P. 45

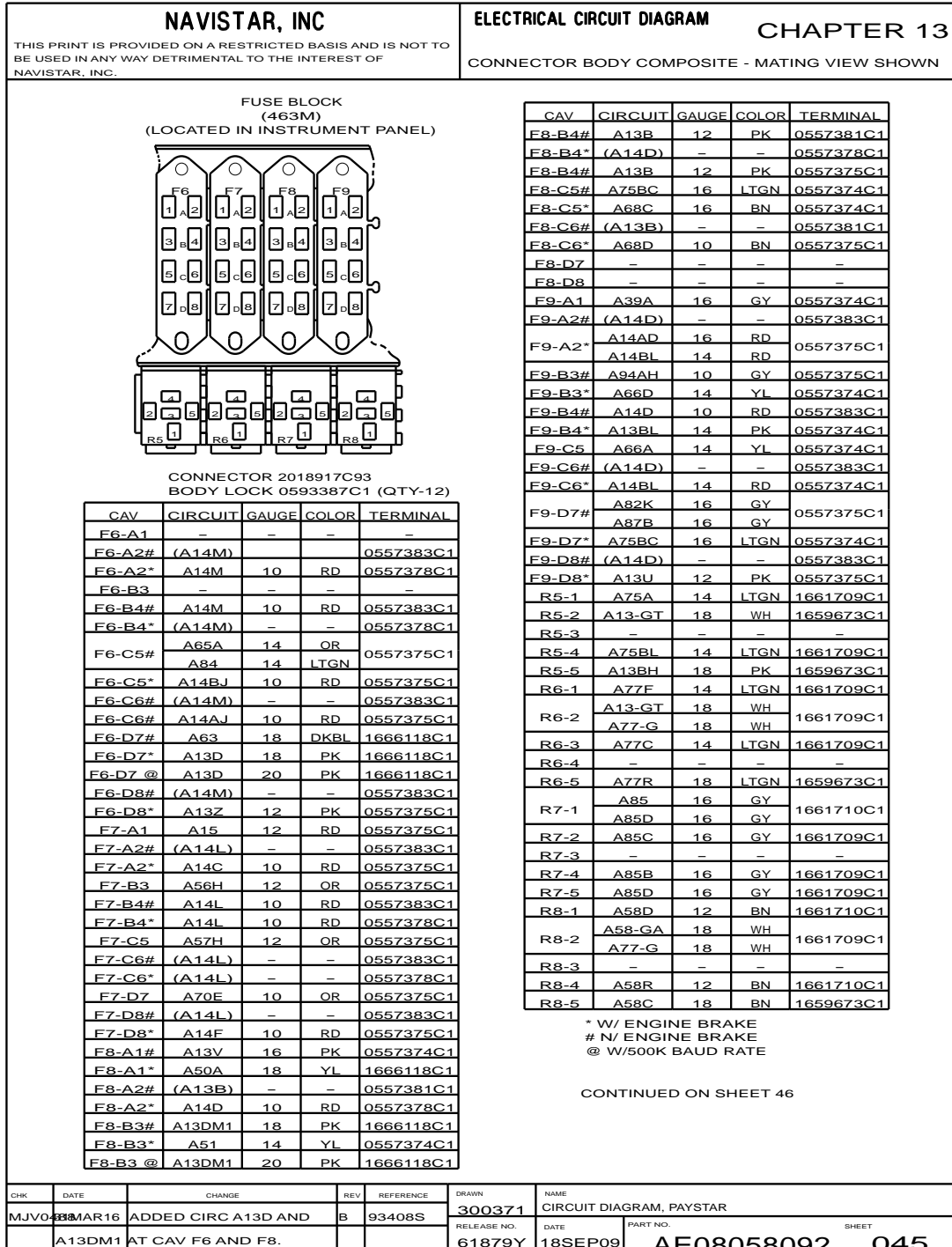


Figure 239 Connector Composites (463M)

13.53. CONNECTOR COMPOSITES (463M), P. 46

<b>NAVISTAR, INC</b> <small>THIS PRINT IS PROVIDED ON A RESTRICTED BASIS AND IS NOT TO BE USED IN ANY WAY DETRIMENTAL TO THE INTEREST OF NAVISTAR, INC.</small>				<b>ELECTRICAL CIRCUIT DIAGRAM</b> <b>CHAPTER 13</b> CONNECTOR BODY COMPOSITE - MATING VIEW SHOWN																																																																																																																													
<table border="1" style="width: 100%; border-collapse: collapse;"> <thead> <tr> <th rowspan="2">FUSE LOCATION</th> <th rowspan="2">CAVITY</th> <th rowspan="2">RATING IN AMP</th> <th colspan="2">PART NUMBER</th> <th rowspan="2">DESCRIPTION</th> </tr> <tr> <th>FUSE</th> <th>BREAKER</th> </tr> </thead> <tbody> <tr><td>F6-A</td><td>1-2</td><td>20</td><td>0131224C1</td><td>-</td><td>-</td></tr> <tr><td>F6-B</td><td>3-4</td><td>10</td><td>0131222C1</td><td>-</td><td>-</td></tr> <tr><td>F6-C</td><td>5-6</td><td>15</td><td>0509080C1</td><td>-</td><td>-</td></tr> <tr><td>F6-D</td><td>7-8</td><td>10</td><td>0131222C1</td><td>-</td><td>-</td></tr> <tr><td>F7-A</td><td>1-2</td><td>25</td><td>0131225C1</td><td>-</td><td>-</td></tr> <tr><td>F7-B</td><td>3-4</td><td>15</td><td>0509080C1</td><td>-</td><td>-</td></tr> <tr><td>F7-C</td><td>5-6</td><td>15</td><td>0509080C1</td><td>-</td><td>-</td></tr> <tr><td>F7-D</td><td>7-8</td><td>30</td><td>0571691C1</td><td>-</td><td>-</td></tr> <tr><td>F8-A</td><td>1-2</td><td>10</td><td>0131222C1</td><td>2007463C1</td><td>-</td></tr> <tr><td>F8-B</td><td>3-4</td><td>10</td><td>0131222C1</td><td>2007466C1</td><td>-</td></tr> <tr><td>F8-C</td><td>5-6</td><td>10</td><td>0131222C1</td><td>-</td><td>-</td></tr> <tr><td>F8-D</td><td>7-8</td><td>-</td><td>-</td><td>-</td><td>-</td></tr> <tr><td>F9-A</td><td>1-2</td><td>15</td><td>0509080C1</td><td>-</td><td>-</td></tr> <tr><td>F9-B</td><td>3-4</td><td>30</td><td>0571691C1</td><td>-</td><td>-</td></tr> <tr><td>F9-C</td><td>5-6</td><td>15</td><td>0509080C1</td><td>-</td><td>-</td></tr> <tr><td>F9-D</td><td>7-8</td><td>15</td><td>-</td><td>2007464C1</td><td>-</td></tr> </tbody> </table> <table border="1" style="width: 100%; border-collapse: collapse;"> <thead> <tr> <th>RELAY LOCATION</th> <th>CAVITY</th> <th>PART NUMBER</th> <th>DESCRIPTION</th> </tr> </thead> <tbody> <tr> <td>R5</td> <td>1, 2, 3, 4, 5</td> <td>2012557C1</td> <td>MAIN CONTROL RELAY</td> </tr> <tr> <td>R6</td> <td>1, 2, 3, 4, 5</td> <td>2012557C1</td> <td>AC RELAY</td> </tr> <tr> <td>R7</td> <td>1, 2, 3, 4, 5</td> <td>2012557C1</td> <td>HORN RELAY</td> </tr> <tr> <td>R8</td> <td>1, 2, 3, 4, 5</td> <td>2012557C1</td> <td>TRAILER MARKER RELAY</td> </tr> </tbody> </table>						FUSE LOCATION	CAVITY	RATING IN AMP	PART NUMBER		DESCRIPTION	FUSE	BREAKER	F6-A	1-2	20	0131224C1	-	-	F6-B	3-4	10	0131222C1	-	-	F6-C	5-6	15	0509080C1	-	-	F6-D	7-8	10	0131222C1	-	-	F7-A	1-2	25	0131225C1	-	-	F7-B	3-4	15	0509080C1	-	-	F7-C	5-6	15	0509080C1	-	-	F7-D	7-8	30	0571691C1	-	-	F8-A	1-2	10	0131222C1	2007463C1	-	F8-B	3-4	10	0131222C1	2007466C1	-	F8-C	5-6	10	0131222C1	-	-	F8-D	7-8	-	-	-	-	F9-A	1-2	15	0509080C1	-	-	F9-B	3-4	30	0571691C1	-	-	F9-C	5-6	15	0509080C1	-	-	F9-D	7-8	15	-	2007464C1	-	RELAY LOCATION	CAVITY	PART NUMBER	DESCRIPTION	R5	1, 2, 3, 4, 5	2012557C1	MAIN CONTROL RELAY	R6	1, 2, 3, 4, 5	2012557C1	AC RELAY	R7	1, 2, 3, 4, 5	2012557C1	HORN RELAY	R8	1, 2, 3, 4, 5	2012557C1	TRAILER MARKER RELAY
FUSE LOCATION	CAVITY	RATING IN AMP	PART NUMBER		DESCRIPTION																																																																																																																												
			FUSE	BREAKER																																																																																																																													
F6-A	1-2	20	0131224C1	-	-																																																																																																																												
F6-B	3-4	10	0131222C1	-	-																																																																																																																												
F6-C	5-6	15	0509080C1	-	-																																																																																																																												
F6-D	7-8	10	0131222C1	-	-																																																																																																																												
F7-A	1-2	25	0131225C1	-	-																																																																																																																												
F7-B	3-4	15	0509080C1	-	-																																																																																																																												
F7-C	5-6	15	0509080C1	-	-																																																																																																																												
F7-D	7-8	30	0571691C1	-	-																																																																																																																												
F8-A	1-2	10	0131222C1	2007463C1	-																																																																																																																												
F8-B	3-4	10	0131222C1	2007466C1	-																																																																																																																												
F8-C	5-6	10	0131222C1	-	-																																																																																																																												
F8-D	7-8	-	-	-	-																																																																																																																												
F9-A	1-2	15	0509080C1	-	-																																																																																																																												
F9-B	3-4	30	0571691C1	-	-																																																																																																																												
F9-C	5-6	15	0509080C1	-	-																																																																																																																												
F9-D	7-8	15	-	2007464C1	-																																																																																																																												
RELAY LOCATION	CAVITY	PART NUMBER	DESCRIPTION																																																																																																																														
R5	1, 2, 3, 4, 5	2012557C1	MAIN CONTROL RELAY																																																																																																																														
R6	1, 2, 3, 4, 5	2012557C1	AC RELAY																																																																																																																														
R7	1, 2, 3, 4, 5	2012557C1	HORN RELAY																																																																																																																														
R8	1, 2, 3, 4, 5	2012557C1	TRAILER MARKER RELAY																																																																																																																														
CONTINUED FROM SHEET 45																																																																																																																																	
CHK	DATE	CHANGE	REV	REFERENCE	DRAWN	NAME																																																																																																																											
DLV1	12JAN11	INITIAL RELEASE.	A	61879Y	300371	CIRCUIT DIAGRAM, PAYSTAR																																																																																																																											
					RELEASE NO.	DATE																																																																																																																											
					61879Y	18SEP09																																																																																																																											
					PART NO.	SHEET																																																																																																																											
					AE08058092	046																																																																																																																											

Figure 240 Connector Composites (463M)

13.54. CONNECTOR COMPOSITES (464M), P. 47

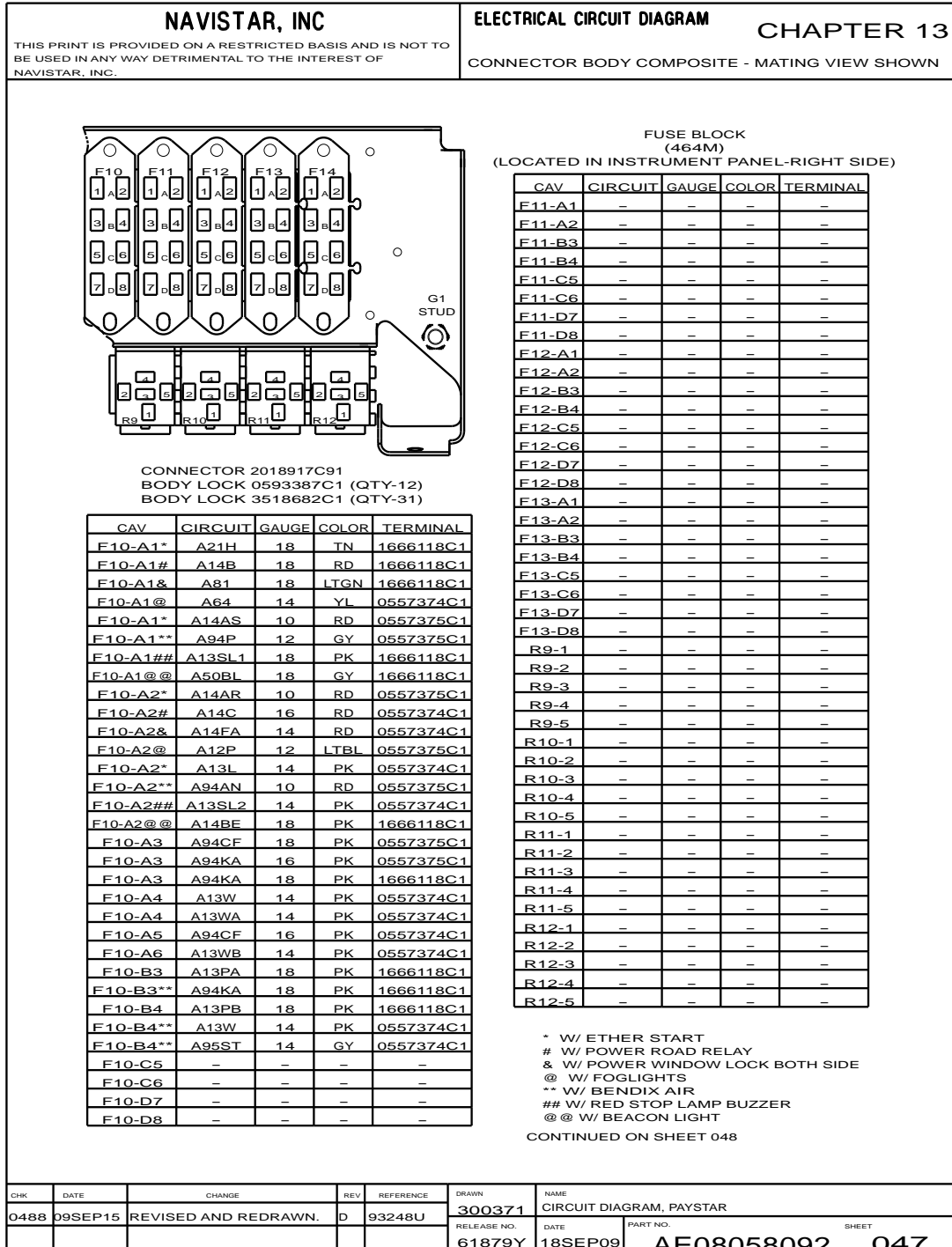


Figure 241 Connector Composites (464M)

13.55. CONNECTOR COMPOSITES (464M), P. 48

<b>NAVISTAR, INC</b>				<b>ELECTRICAL CIRCUIT DIAGRAM CHAPTER 13</b>																																																																																																																																																						
THIS PRINT IS PROVIDED ON A RESTRICTED BASIS AND IS NOT TO BE USED IN ANY WAY DETRIMENTAL TO THE INTEREST OF NAVISTAR, INC.				CONNECTOR BODY COMPOSITE - MATING VIEW SHOWN																																																																																																																																																						
<table border="1" style="width: 100%; border-collapse: collapse; margin-bottom: 20px;"> <thead> <tr> <th rowspan="2">FUSE LOCATION</th> <th rowspan="2">CAVITY</th> <th rowspan="2">RATING IN AMP</th> <th colspan="2">PART NUMBER</th> <th rowspan="2">DESCRIPTION</th> </tr> <tr> <th>FUSE</th> <th>BREAKER</th> </tr> </thead> <tbody> <tr><td>F10-A</td><td>1-2</td><td>15</td><td>0509080C1</td><td>-</td><td>-</td></tr> <tr><td>F10-B</td><td>3-4</td><td>10</td><td>0131222C1</td><td>-</td><td>-</td></tr> <tr><td>F10-C</td><td>5-6</td><td>-</td><td>-</td><td>-</td><td>-</td></tr> <tr><td>F10-D</td><td>7-8</td><td>-</td><td>-</td><td>-</td><td>-</td></tr> <tr><td>F11-A</td><td>1-2</td><td>-</td><td>-</td><td>-</td><td>-</td></tr> <tr><td>F11-B</td><td>3-4</td><td>-</td><td>-</td><td>-</td><td>-</td></tr> <tr><td>F11-C</td><td>5-6</td><td>-</td><td>-</td><td>-</td><td>-</td></tr> <tr><td>F11-D</td><td>7-8</td><td>-</td><td>-</td><td>-</td><td>-</td></tr> <tr><td>F12-A</td><td>1-2</td><td>-</td><td>-</td><td>-</td><td>-</td></tr> <tr><td>F12-B</td><td>3-4</td><td>-</td><td>-</td><td>-</td><td>-</td></tr> <tr><td>F12-C</td><td>5-6</td><td>-</td><td>-</td><td>-</td><td>-</td></tr> <tr><td>F12-D</td><td>7-8</td><td>-</td><td>-</td><td>-</td><td>-</td></tr> <tr><td>F13-A</td><td>1-2</td><td>-</td><td>-</td><td>-</td><td>-</td></tr> <tr><td>F13-B</td><td>3-4</td><td>-</td><td>-</td><td>-</td><td>-</td></tr> <tr><td>F13-C</td><td>5-6</td><td>-</td><td>-</td><td>-</td><td>-</td></tr> <tr><td>F13-D</td><td>7-8</td><td>-</td><td>-</td><td>-</td><td>-</td></tr> <tr><td>F14-A</td><td>1-2</td><td>-</td><td>-</td><td>-</td><td>-</td></tr> <tr><td>F14-B</td><td>3-4</td><td>-</td><td>-</td><td>-</td><td>-</td></tr> <tr><td>F14-C</td><td>5-6</td><td>-</td><td>-</td><td>-</td><td>-</td></tr> <tr><td>F14-D</td><td>7-8</td><td>-</td><td>-</td><td>-</td><td>-</td></tr> </tbody> </table> <table border="1" style="width: 100%; border-collapse: collapse;"> <thead> <tr> <th>RELAY LOCATION</th> <th>CAVITY</th> <th>PART NUMBER</th> <th>DESCRIPTION</th> </tr> </thead> <tbody> <tr><td>R9</td><td>1, 2, 3, 4, 5</td><td>-</td><td>-</td></tr> <tr><td>R10</td><td>1, 2, 3, 4, 5</td><td>-</td><td>-</td></tr> <tr><td>R11</td><td>1, 2, 3, 4, 5</td><td>-</td><td>-</td></tr> <tr><td>R12</td><td>1, 2, 3, 4, 5</td><td>-</td><td>-</td></tr> </tbody> </table>							FUSE LOCATION	CAVITY	RATING IN AMP	PART NUMBER		DESCRIPTION	FUSE	BREAKER	F10-A	1-2	15	0509080C1	-	-	F10-B	3-4	10	0131222C1	-	-	F10-C	5-6	-	-	-	-	F10-D	7-8	-	-	-	-	F11-A	1-2	-	-	-	-	F11-B	3-4	-	-	-	-	F11-C	5-6	-	-	-	-	F11-D	7-8	-	-	-	-	F12-A	1-2	-	-	-	-	F12-B	3-4	-	-	-	-	F12-C	5-6	-	-	-	-	F12-D	7-8	-	-	-	-	F13-A	1-2	-	-	-	-	F13-B	3-4	-	-	-	-	F13-C	5-6	-	-	-	-	F13-D	7-8	-	-	-	-	F14-A	1-2	-	-	-	-	F14-B	3-4	-	-	-	-	F14-C	5-6	-	-	-	-	F14-D	7-8	-	-	-	-	RELAY LOCATION	CAVITY	PART NUMBER	DESCRIPTION	R9	1, 2, 3, 4, 5	-	-	R10	1, 2, 3, 4, 5	-	-	R11	1, 2, 3, 4, 5	-	-	R12	1, 2, 3, 4, 5	-	-
FUSE LOCATION	CAVITY	RATING IN AMP	PART NUMBER		DESCRIPTION																																																																																																																																																					
			FUSE	BREAKER																																																																																																																																																						
F10-A	1-2	15	0509080C1	-	-																																																																																																																																																					
F10-B	3-4	10	0131222C1	-	-																																																																																																																																																					
F10-C	5-6	-	-	-	-																																																																																																																																																					
F10-D	7-8	-	-	-	-																																																																																																																																																					
F11-A	1-2	-	-	-	-																																																																																																																																																					
F11-B	3-4	-	-	-	-																																																																																																																																																					
F11-C	5-6	-	-	-	-																																																																																																																																																					
F11-D	7-8	-	-	-	-																																																																																																																																																					
F12-A	1-2	-	-	-	-																																																																																																																																																					
F12-B	3-4	-	-	-	-																																																																																																																																																					
F12-C	5-6	-	-	-	-																																																																																																																																																					
F12-D	7-8	-	-	-	-																																																																																																																																																					
F13-A	1-2	-	-	-	-																																																																																																																																																					
F13-B	3-4	-	-	-	-																																																																																																																																																					
F13-C	5-6	-	-	-	-																																																																																																																																																					
F13-D	7-8	-	-	-	-																																																																																																																																																					
F14-A	1-2	-	-	-	-																																																																																																																																																					
F14-B	3-4	-	-	-	-																																																																																																																																																					
F14-C	5-6	-	-	-	-																																																																																																																																																					
F14-D	7-8	-	-	-	-																																																																																																																																																					
RELAY LOCATION	CAVITY	PART NUMBER	DESCRIPTION																																																																																																																																																							
R9	1, 2, 3, 4, 5	-	-																																																																																																																																																							
R10	1, 2, 3, 4, 5	-	-																																																																																																																																																							
R11	1, 2, 3, 4, 5	-	-																																																																																																																																																							
R12	1, 2, 3, 4, 5	-	-																																																																																																																																																							
CONTINUED FROM SHEET 47																																																																																																																																																										
CHK	DATE	CHANGE	REV	REFERENCE	DRAWN	NAME																																																																																																																																																				
DLV1	12JAN11	INITIAL RELEASE.	A	61879Y	300371	CIRCUIT DIAGRAM, PAYSTAR																																																																																																																																																				
					RELEASE NO.	DATE																																																																																																																																																				
					61879Y	18SEP09																																																																																																																																																				
					PART NO.	SHEET																																																																																																																																																				
					AE08058092	048																																																																																																																																																				

Figure 242 Connector Composites (464M)

13.56. CONNECTOR COMPOSITES (464M), P. 49

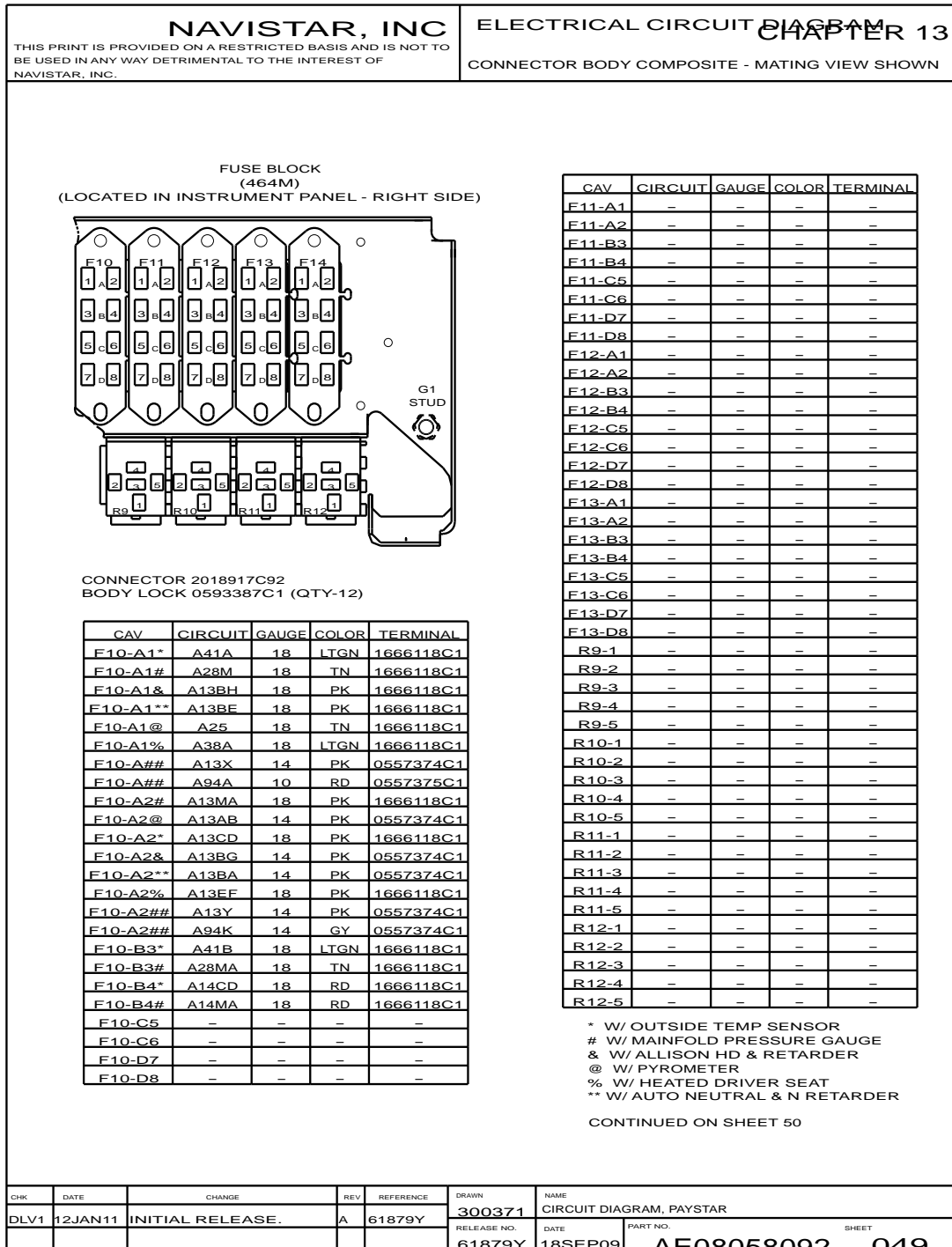


Figure 243 Connector Composites (464M)

13.57. CONNECTOR COMPOSITES (464M), P. 50

<p><b>NAVISTAR, INC</b></p> <p>THIS PRINT IS PROVIDED ON A RESTRICTED BASIS AND IS NOT TO BE USED IN ANY WAY DETRIMENTAL TO THE INTEREST OF NAVISTAR, INC.</p>	<p><b>ELECTRICAL CIRCUIT DIAGRAM</b></p> <p><b>CHAPTER 13</b></p> <p>CONNECTOR BODY COMPOSITE - MATING VIEW SHOWN</p>
--	---

FUSE LOCATION	CAVITY	RATING IN AMP	PART NUMBER		DESCRIPTION
			FUSE	BREAKER	
F10-A	1-2	15	0509080C1	-	-
F10-B	3-4	10	0131222C1	-	-
F10-C	5-6	-	-	-	-
F10-D	7-8	-	-	-	-
F11-A	1-2	-	-	-	-
F11-B	3-4	-	-	-	-
F11-C	5-6	-	-	-	-
F11-D	7-8	-	-	-	-
F12-A	1-2	-	-	-	-
F12-B	3-4	-	-	-	-
F12-C	5-6	-	-	-	-
F12-D	7-8	-	-	-	-
F13-A	1-2	-	-	-	-
F13-B	3-4	-	-	-	-
F13-C	5-6	-	-	-	-
F13-D	7-8	-	-	-	-
F14-A	1-2	-	-	-	-
F14-B	3-4	-	-	-	-
F14-C	5-6	-	-	-	-
F14-D	7-8	-	-	-	-

RELAY LOCATION	CAVITY	PART NUMBER	DESCRIPTION
R9	1, 2, 3, 4, 5	-	-
R10	1, 2, 3, 4, 5	-	-
R11	1, 2, 3, 4, 5	-	-
R12	1, 2, 3, 4, 5	-	-

CONTINUED FROM SHEET 49

CHK	DATE	CHANGE	REV	REFERENCE	DRAWN	NAME
DLV1	12JAN11	INITIAL RELEASE.	A	61879Y	300371	CIRCUIT DIAGRAM, PAYSTAR
					RELEASE NO.	DATE
					61879Y	18SEP09
					PART NO.	SHEET
					AE08058092	050

Figure 244 Connector Composites (464M)

13.58. CONNECTOR COMPOSITES (464M), P. 51

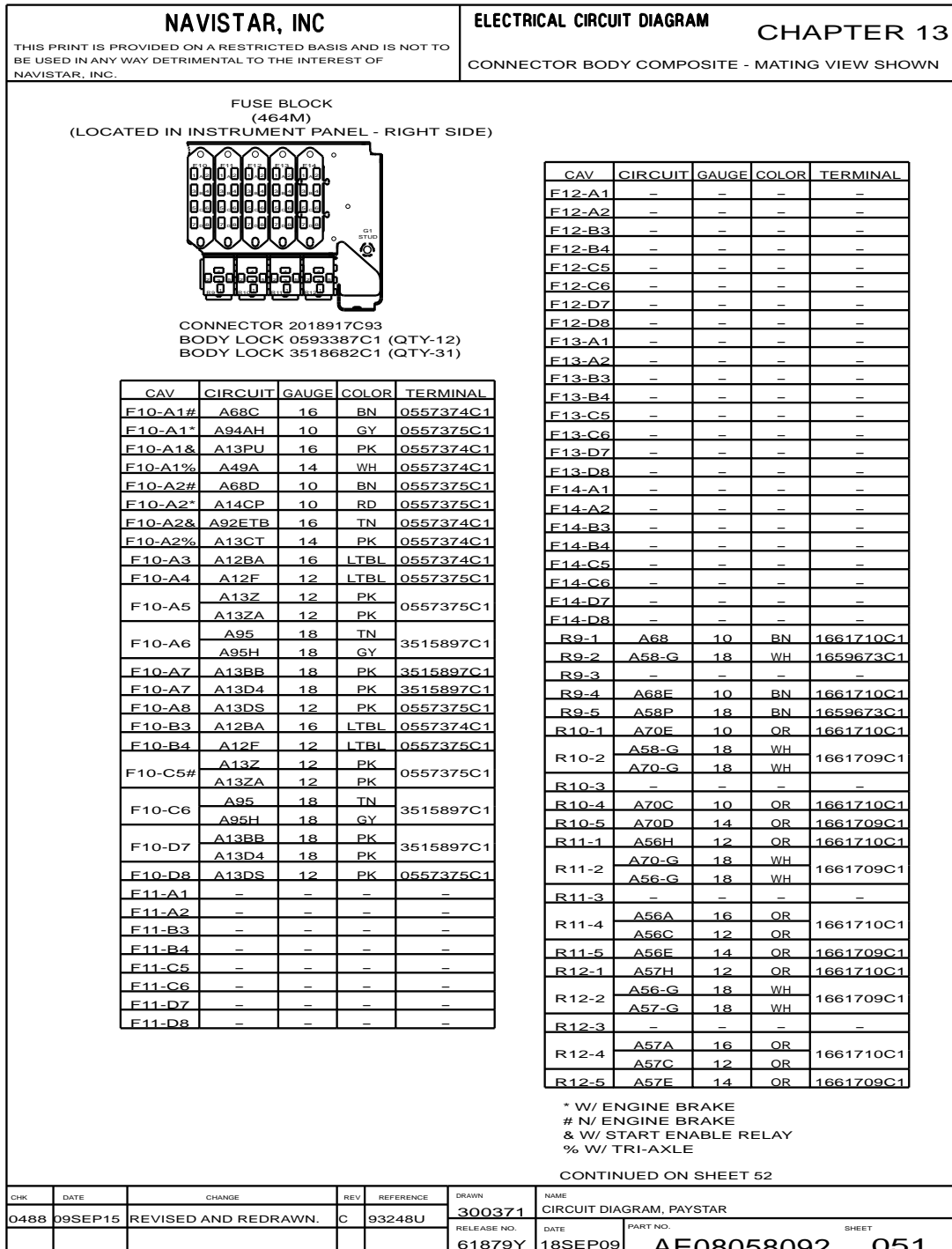


Figure 245 Connector Composites (464M)

13.59. CONNECTOR COMPOSITES (464M), P. 52

<b>NAVISTAR, INC</b>				<b>ELECTRICAL CIRCUIT DIAGRAM CHAPTER 13</b>																																																																																																																																																						
THIS PRINT IS PROVIDED ON A RESTRICTED BASIS AND IS NOT TO BE USED IN ANY WAY DETRIMENTAL TO THE INTEREST OF NAVISTAR, INC.				CONNECTOR BODY COMPOSITE - MATING VIEW SHOWN																																																																																																																																																						
<table border="1" style="width: 100%; border-collapse: collapse; margin-bottom: 20px;"> <thead> <tr> <th rowspan="2">FUSE LOCATION</th> <th rowspan="2">CAVITY</th> <th rowspan="2">RATING IN AMP</th> <th colspan="2">PART NUMBER</th> <th rowspan="2">DESCRIPTION</th> </tr> <tr> <th>FUSE</th> <th>BREAKER</th> </tr> </thead> <tbody> <tr><td>F10-A</td><td>1-2</td><td>15</td><td>0509080C1</td><td>-</td><td>-</td></tr> <tr><td>F10-B</td><td>3-4</td><td>10</td><td>0131222C1</td><td>-</td><td>-</td></tr> <tr><td>F10-C</td><td>5-6</td><td>10</td><td>0131222C1</td><td>-</td><td>-</td></tr> <tr><td>F10-D</td><td>7-8</td><td>15</td><td>0509080C1</td><td>-</td><td>-</td></tr> <tr><td>F11-A</td><td>1-2</td><td>-</td><td>-</td><td>-</td><td>-</td></tr> <tr><td>F11-B</td><td>3-4</td><td>-</td><td>-</td><td>-</td><td>-</td></tr> <tr><td>F11-C</td><td>5-6</td><td>-</td><td>-</td><td>-</td><td>-</td></tr> <tr><td>F11-D</td><td>7-8</td><td>-</td><td>-</td><td>-</td><td>-</td></tr> <tr><td>F12-A</td><td>1-2</td><td>-</td><td>-</td><td>-</td><td>-</td></tr> <tr><td>F12-B</td><td>3-4</td><td>-</td><td>-</td><td>-</td><td>-</td></tr> <tr><td>F12-C</td><td>5-6</td><td>-</td><td>-</td><td>-</td><td>-</td></tr> <tr><td>F12-D</td><td>7-8</td><td>-</td><td>-</td><td>-</td><td>-</td></tr> <tr><td>F13-A</td><td>1-2</td><td>-</td><td>-</td><td>-</td><td>-</td></tr> <tr><td>F13-B</td><td>3-4</td><td>-</td><td>-</td><td>-</td><td>-</td></tr> <tr><td>F13-C</td><td>5-6</td><td>-</td><td>-</td><td>-</td><td>-</td></tr> <tr><td>F13-D</td><td>7-8</td><td>-</td><td>-</td><td>-</td><td>-</td></tr> <tr><td>F14-A</td><td>1-2</td><td>-</td><td>-</td><td>-</td><td>-</td></tr> <tr><td>F14-B</td><td>3-4</td><td>-</td><td>-</td><td>-</td><td>-</td></tr> <tr><td>F14-C</td><td>5-6</td><td>-</td><td>-</td><td>-</td><td>-</td></tr> <tr><td>F14-D</td><td>7-8</td><td>-</td><td>-</td><td>-</td><td>-</td></tr> </tbody> </table> <table border="1" style="width: 100%; border-collapse: collapse;"> <thead> <tr> <th>RELAY LOCATION</th> <th>CAVITY</th> <th>PART NUMBER</th> <th>DESCRIPTION</th> </tr> </thead> <tbody> <tr> <td>R9</td> <td>1, 2, 3, 4, 5</td> <td>2012557C1</td> <td>CAB AND TRAILER RELAY</td> </tr> <tr> <td>R10</td> <td>1, 2, 3, 4, 5</td> <td>2012557C1</td> <td>STOP LIGHT RELAY</td> </tr> <tr> <td>R11</td> <td>1, 2, 3, 4, 5</td> <td>3607384C1</td> <td>LEFT TURN RELAY</td> </tr> <tr> <td>R12</td> <td>1, 2, 3, 4, 5</td> <td>3607384C1</td> <td>RIGHT TURN RELAY</td> </tr> </tbody> </table>							FUSE LOCATION	CAVITY	RATING IN AMP	PART NUMBER		DESCRIPTION	FUSE	BREAKER	F10-A	1-2	15	0509080C1	-	-	F10-B	3-4	10	0131222C1	-	-	F10-C	5-6	10	0131222C1	-	-	F10-D	7-8	15	0509080C1	-	-	F11-A	1-2	-	-	-	-	F11-B	3-4	-	-	-	-	F11-C	5-6	-	-	-	-	F11-D	7-8	-	-	-	-	F12-A	1-2	-	-	-	-	F12-B	3-4	-	-	-	-	F12-C	5-6	-	-	-	-	F12-D	7-8	-	-	-	-	F13-A	1-2	-	-	-	-	F13-B	3-4	-	-	-	-	F13-C	5-6	-	-	-	-	F13-D	7-8	-	-	-	-	F14-A	1-2	-	-	-	-	F14-B	3-4	-	-	-	-	F14-C	5-6	-	-	-	-	F14-D	7-8	-	-	-	-	RELAY LOCATION	CAVITY	PART NUMBER	DESCRIPTION	R9	1, 2, 3, 4, 5	2012557C1	CAB AND TRAILER RELAY	R10	1, 2, 3, 4, 5	2012557C1	STOP LIGHT RELAY	R11	1, 2, 3, 4, 5	3607384C1	LEFT TURN RELAY	R12	1, 2, 3, 4, 5	3607384C1	RIGHT TURN RELAY
FUSE LOCATION	CAVITY	RATING IN AMP	PART NUMBER		DESCRIPTION																																																																																																																																																					
			FUSE	BREAKER																																																																																																																																																						
F10-A	1-2	15	0509080C1	-	-																																																																																																																																																					
F10-B	3-4	10	0131222C1	-	-																																																																																																																																																					
F10-C	5-6	10	0131222C1	-	-																																																																																																																																																					
F10-D	7-8	15	0509080C1	-	-																																																																																																																																																					
F11-A	1-2	-	-	-	-																																																																																																																																																					
F11-B	3-4	-	-	-	-																																																																																																																																																					
F11-C	5-6	-	-	-	-																																																																																																																																																					
F11-D	7-8	-	-	-	-																																																																																																																																																					
F12-A	1-2	-	-	-	-																																																																																																																																																					
F12-B	3-4	-	-	-	-																																																																																																																																																					
F12-C	5-6	-	-	-	-																																																																																																																																																					
F12-D	7-8	-	-	-	-																																																																																																																																																					
F13-A	1-2	-	-	-	-																																																																																																																																																					
F13-B	3-4	-	-	-	-																																																																																																																																																					
F13-C	5-6	-	-	-	-																																																																																																																																																					
F13-D	7-8	-	-	-	-																																																																																																																																																					
F14-A	1-2	-	-	-	-																																																																																																																																																					
F14-B	3-4	-	-	-	-																																																																																																																																																					
F14-C	5-6	-	-	-	-																																																																																																																																																					
F14-D	7-8	-	-	-	-																																																																																																																																																					
RELAY LOCATION	CAVITY	PART NUMBER	DESCRIPTION																																																																																																																																																							
R9	1, 2, 3, 4, 5	2012557C1	CAB AND TRAILER RELAY																																																																																																																																																							
R10	1, 2, 3, 4, 5	2012557C1	STOP LIGHT RELAY																																																																																																																																																							
R11	1, 2, 3, 4, 5	3607384C1	LEFT TURN RELAY																																																																																																																																																							
R12	1, 2, 3, 4, 5	3607384C1	RIGHT TURN RELAY																																																																																																																																																							
CONTINUED FROM SHEET 51																																																																																																																																																										
CHK	DATE	CHANGE	REV	REFERENCE	DRAWN	NAME																																																																																																																																																				
DLV1	12JAN11	INITIAL RELEASE.	A	61879Y	300371	CIRCUIT DIAGRAM, PAYSTAR																																																																																																																																																				
					RELEASE NO.	DATE																																																																																																																																																				
					61879Y	18SEP09																																																																																																																																																				
					PART NO.	SHEET																																																																																																																																																				
					AE08058092	052																																																																																																																																																				

Figure 246 Connector Composites (464M)



13.60. CONNECTOR COMPOSITES (465M / 466M / 468F / 469ML), P. 53

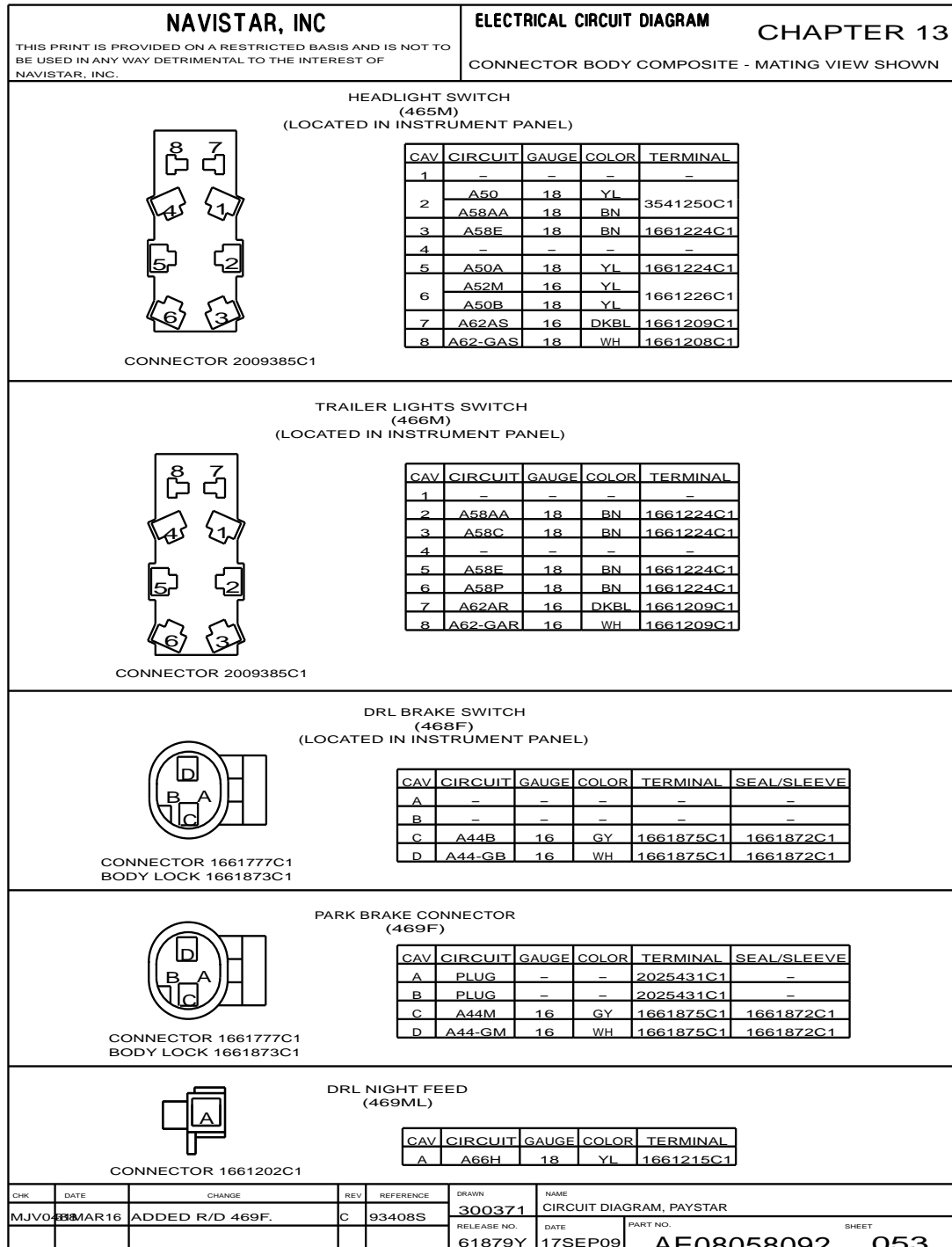


Figure 247 Connector Composites (465M / 466M / 468F / 469ML)

13.61. CONNECTOR COMPOSITES (471), P. 54

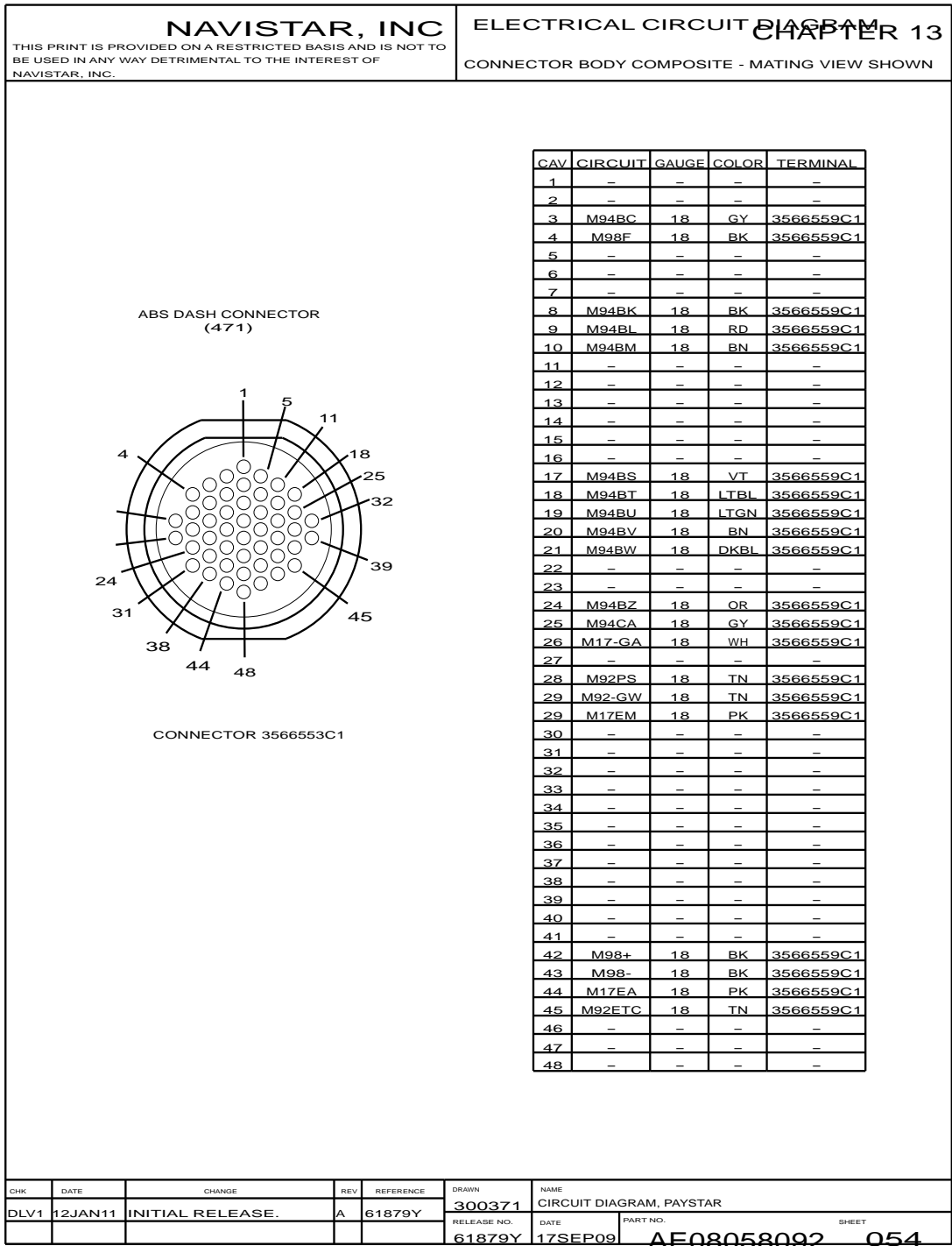


Figure 248 Connector Composites (471)

13.62. CONNECTOR COMPOSITES (471), P. 55

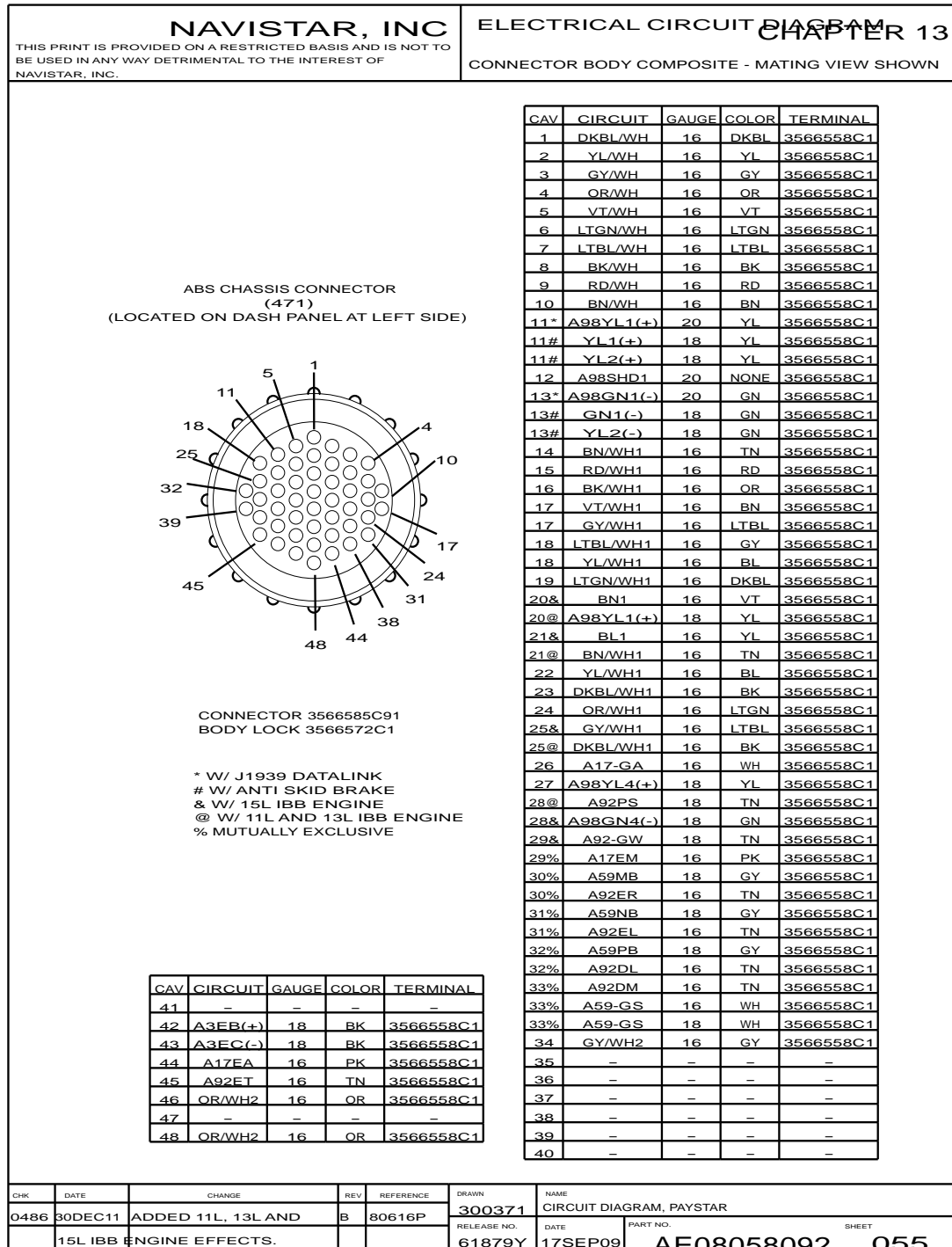


Figure 249 Connector Composites (471)

13.63. CONNECTOR COMPOSITES (471), P. 55A

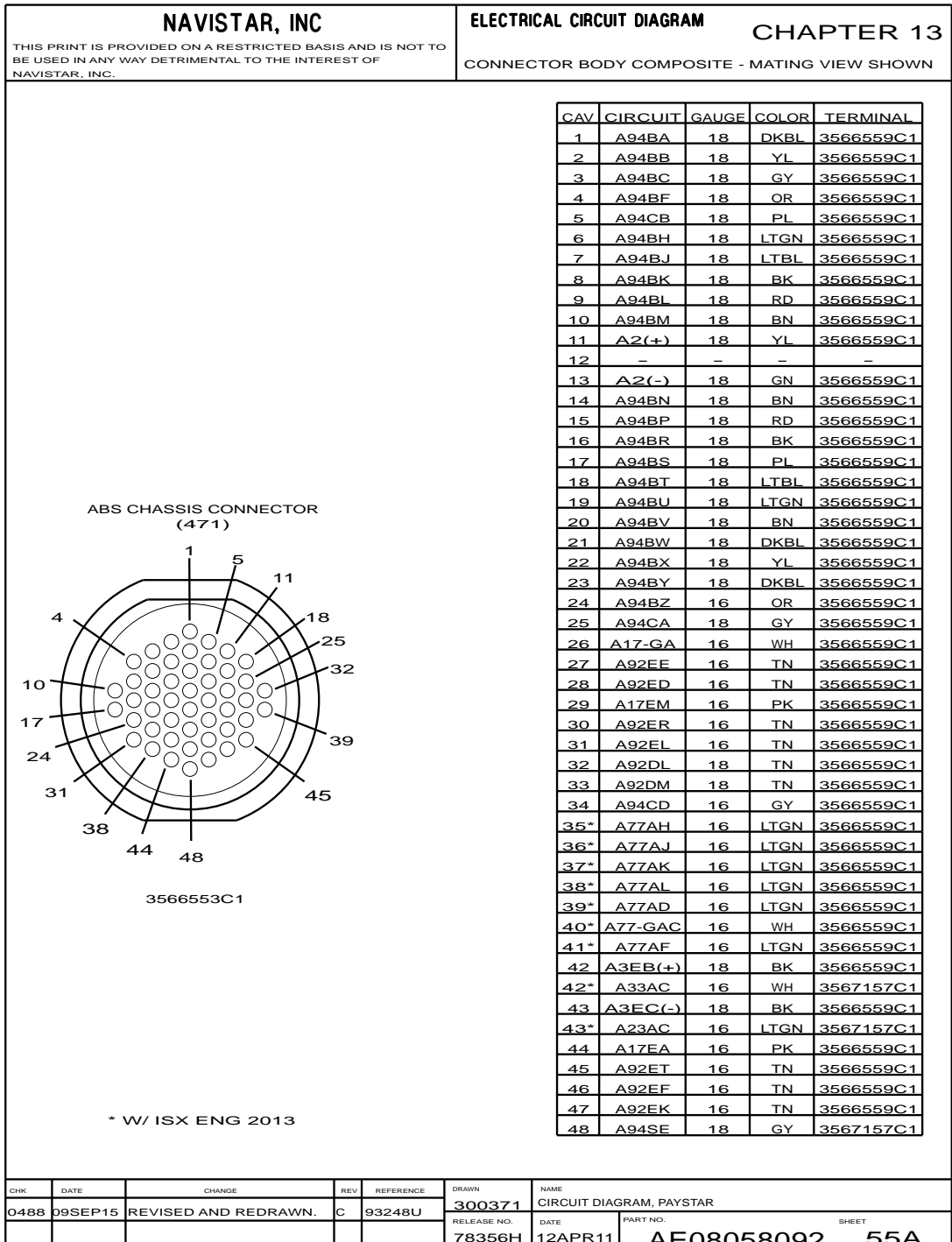


Figure 250 Connector Composites (471)

13.64. CONNECTOR COMPOSITES (471), P. 55B

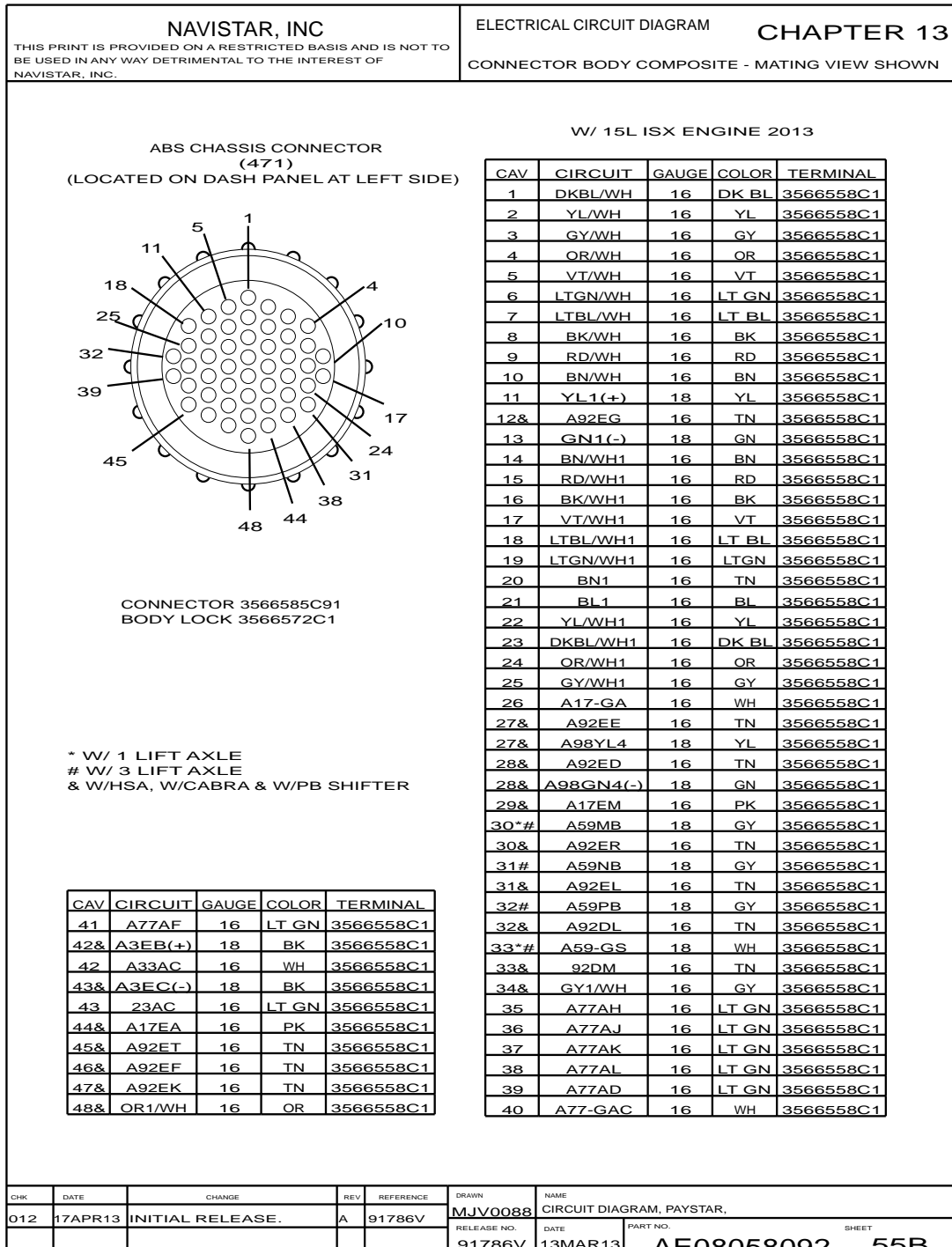


Figure 251 Connector Composites (471)

13.65. CONNECTOR COMPOSITES (471A), P. 55C

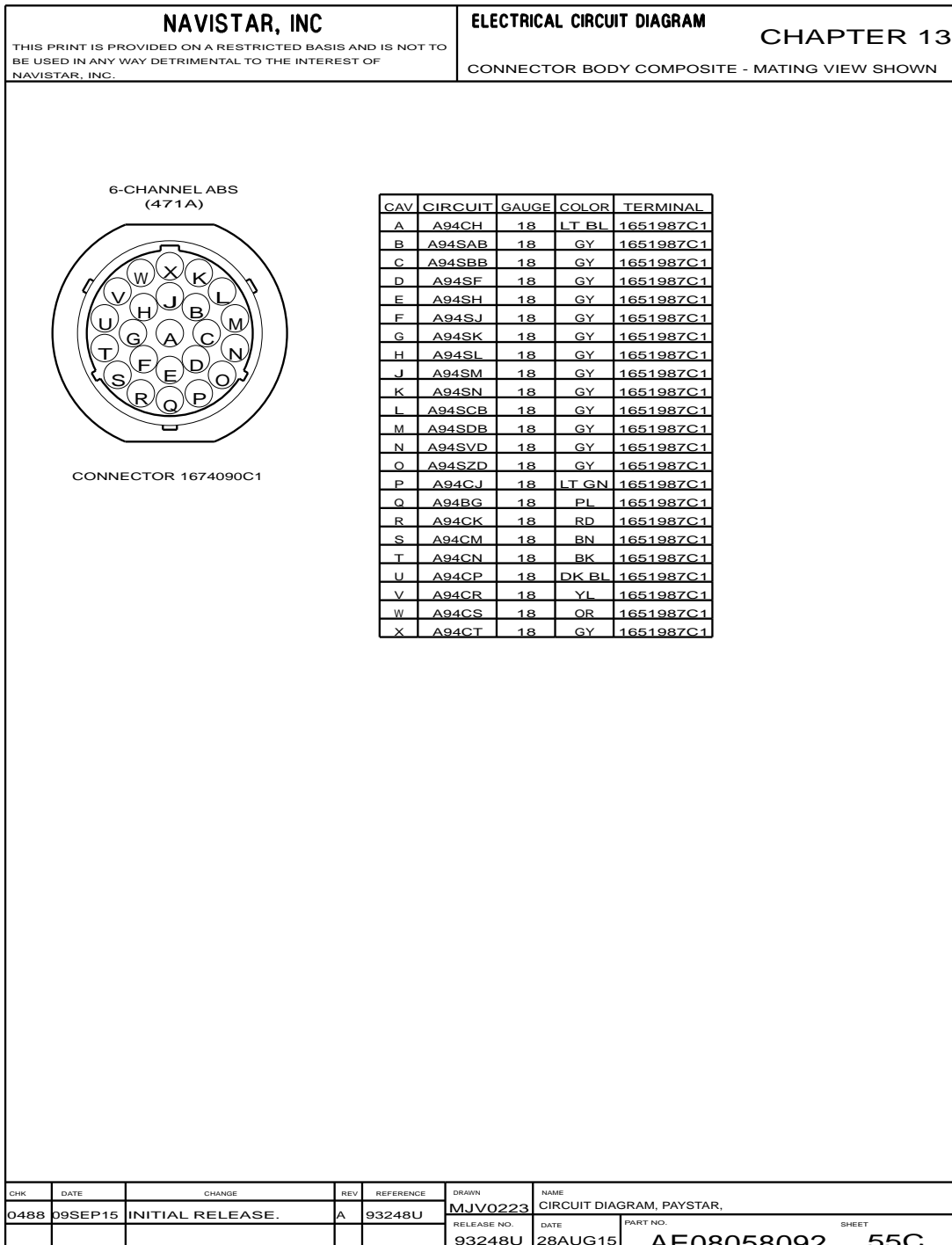


Figure 252 Connector Composites (471A)

13.66. CONNECTOR COMPOSITES (471AF / 480F / 480M / 481M / 482M / 489), P. 56

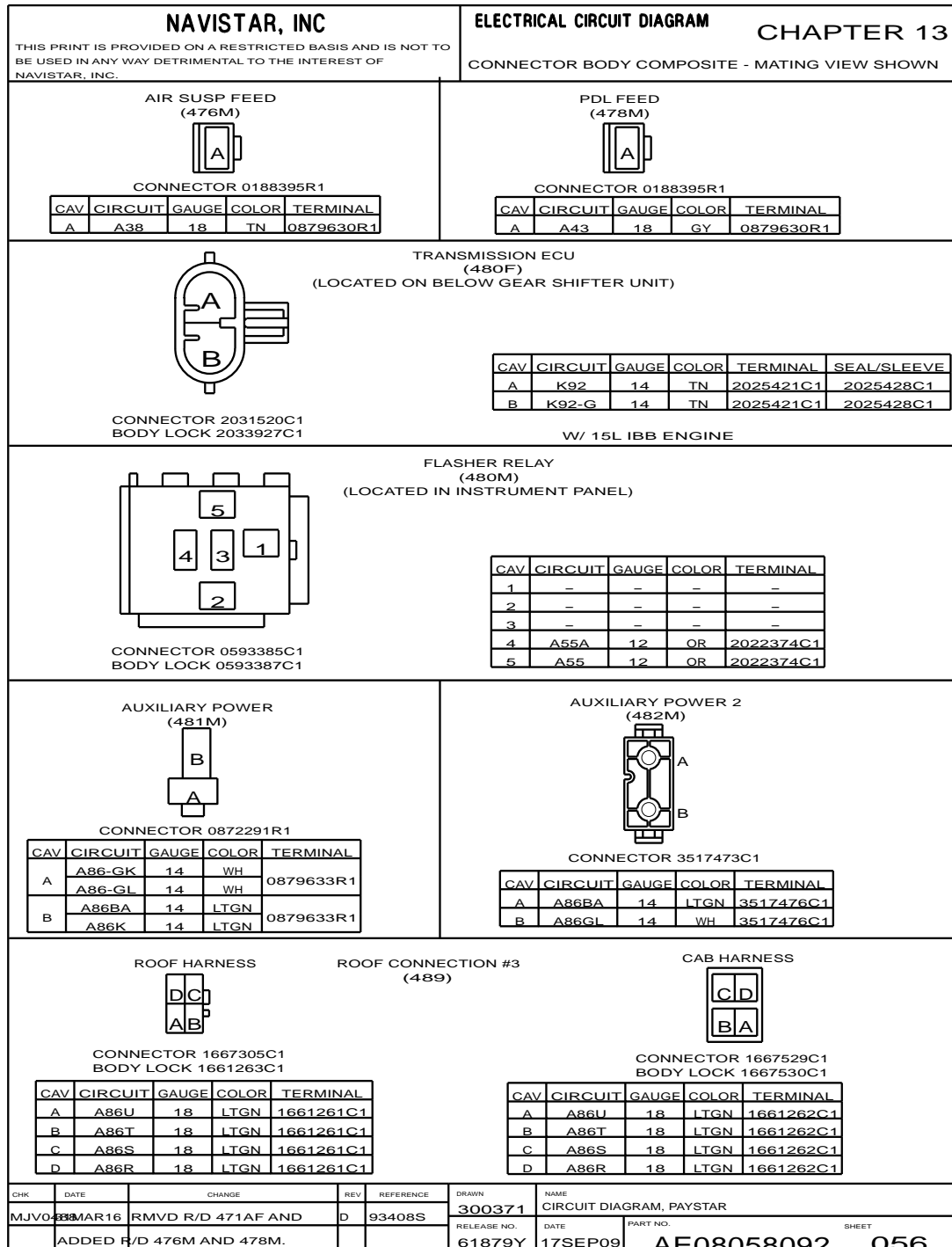


Figure 253 Connector Composites (471AF / 480F / 480M / 481M / 482M / 489)

13.67. CONNECTOR COMPOSITES (491F / 492M / 494M), P. 57

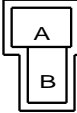
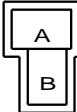


<b>NAVISTAR, INC</b>				<b>ELECTRICAL CIRCUIT DIAGRAM</b>				<b>CHAPTER 13</b>																																																																														
THIS PRINT IS PROVIDED ON A RESTRICTED BASIS AND IS NOT TO BE USED IN ANY WAY DETRIMENTAL TO THE INTEREST OF NAVISTAR, INC.				CONNECTOR BODY COMPOSITE - MATING VIEW SHOWN																																																																																		
PYROMETER CABLE ASSY (491F) (LOCATED IN INSTRUMENT PANEL - CENTER)																																																																																						
				<table border="1" style="width:100%; border-collapse: collapse; font-size: x-small;"> <thead> <tr> <th>CAV</th> <th>CIRCUIT</th> <th>GAUGE</th> <th>COLOR</th> <th>TERMINAL</th> </tr> </thead> <tbody> <tr> <td>A</td> <td>RD</td> <td>16</td> <td>RD</td> <td>ASSY</td> </tr> <tr> <td>B</td> <td>YL</td> <td>16</td> <td>YL</td> <td>ASSY</td> </tr> </tbody> </table>								CAV	CIRCUIT	GAUGE	COLOR	TERMINAL	A	RD	16	RD	ASSY	B	YL	16	YL	ASSY																																																												
CAV	CIRCUIT	GAUGE	COLOR	TERMINAL																																																																																		
A	RD	16	RD	ASSY																																																																																		
B	YL	16	YL	ASSY																																																																																		
CONNECTOR 2022397C91																																																																																						
PYROMETER MODULE ASSY (492M) (LOCATED IN INSTRUMENT PANEL - CENTER)																																																																																						
				<table border="1" style="width:100%; border-collapse: collapse; font-size: x-small;"> <thead> <tr> <th>CAV</th> <th>CIRCUIT</th> <th>GAUGE</th> <th>COLOR</th> <th>TERMINAL</th> </tr> </thead> <tbody> <tr> <td>A</td> <td>RD</td> <td>16</td> <td>RD</td> <td>ASSY</td> </tr> <tr> <td>B</td> <td>YL</td> <td>16</td> <td>YL</td> <td>ASSY</td> </tr> </tbody> </table>								CAV	CIRCUIT	GAUGE	COLOR	TERMINAL	A	RD	16	RD	ASSY	B	YL	16	YL	ASSY																																																												
CAV	CIRCUIT	GAUGE	COLOR	TERMINAL																																																																																		
A	RD	16	RD	ASSY																																																																																		
B	YL	16	YL	ASSY																																																																																		
CONNECTOR 2022397C91																																																																																						
FOG LIGHT FEED (493ML)																																																																																						
				<table border="1" style="width:100%; border-collapse: collapse; font-size: x-small;"> <thead> <tr> <th>CAV</th> <th>CIRCUIT</th> <th>GAUGE</th> <th>COLOR</th> <th>TERMINAL</th> </tr> </thead> <tbody> <tr> <td>A</td> <td>A64D</td> <td>14</td> <td>YL</td> <td>1661218C1</td> </tr> </tbody> </table>								CAV	CIRCUIT	GAUGE	COLOR	TERMINAL	A	A64D	14	YL	1661218C1																																																																	
CAV	CIRCUIT	GAUGE	COLOR	TERMINAL																																																																																		
A	A64D	14	YL	1661218C1																																																																																		
CONNECTOR 1661202C1																																																																																						
I1 IGNITION ADAPTER (494M) (LOCATED IN INSTRUMENT PANEL)																																																																																						
				<table border="1" style="width:100%; border-collapse: collapse; font-size: x-small;"> <thead> <tr> <th>CAV</th> <th>CIRCUIT</th> <th>GAUGE</th> <th>COLOR</th> <th>TERMINAL</th> </tr> </thead> <tbody> <tr> <td>A</td> <td>A13F</td> <td>12</td> <td>PK</td> <td>3566715C1</td> </tr> <tr> <td>B#</td> <td>A13Z</td> <td>12</td> <td>PK</td> <td>3566715C1</td> </tr> <tr> <td>B*</td> <td>A13ZA</td> <td>12</td> <td>PK</td> <td>3566715C1</td> </tr> <tr> <td>C&amp;</td> <td>A13DS</td> <td>12</td> <td>PK</td> <td>3566715C1</td> </tr> <tr> <td>C%</td> <td>A13CD</td> <td>18</td> <td>PK</td> <td>1661208C1</td> </tr> <tr> <td>D</td> <td>A13X</td> <td>18</td> <td>PK</td> <td>1661208C1</td> </tr> <tr> <td>E</td> <td>-</td> <td>-</td> <td>-</td> <td>-</td> </tr> <tr> <td>F</td> <td>-</td> <td>-</td> <td>-</td> <td>-</td> </tr> <tr> <td>G@@</td> <td>A13NA</td> <td>14</td> <td>PK</td> <td>3566715C1</td> </tr> <tr> <td>G##</td> <td>A13NA</td> <td>18</td> <td>PK</td> <td>1661208C1</td> </tr> <tr> <td>H</td> <td>A13AB</td> <td>14</td> <td>PK</td> <td>1661209C1</td> </tr> <tr> <td>J</td> <td>-</td> <td>-</td> <td>-</td> <td>-</td> </tr> <tr> <td>K@</td> <td>A13L</td> <td>14</td> <td>PK</td> <td>1661209C1</td> </tr> <tr> <td>K**</td> <td>A13MA</td> <td>18</td> <td>PK</td> <td>1661208C1</td> </tr> </tbody> </table>								CAV	CIRCUIT	GAUGE	COLOR	TERMINAL	A	A13F	12	PK	3566715C1	B#	A13Z	12	PK	3566715C1	B*	A13ZA	12	PK	3566715C1	C&	A13DS	12	PK	3566715C1	C%	A13CD	18	PK	1661208C1	D	A13X	18	PK	1661208C1	E	-	-	-	-	F	-	-	-	-	G@@	A13NA	14	PK	3566715C1	G##	A13NA	18	PK	1661208C1	H	A13AB	14	PK	1661209C1	J	-	-	-	-	K@	A13L	14	PK	1661209C1	K**	A13MA	18	PK	1661208C1
CAV	CIRCUIT	GAUGE	COLOR	TERMINAL																																																																																		
A	A13F	12	PK	3566715C1																																																																																		
B#	A13Z	12	PK	3566715C1																																																																																		
B*	A13ZA	12	PK	3566715C1																																																																																		
C&	A13DS	12	PK	3566715C1																																																																																		
C%	A13CD	18	PK	1661208C1																																																																																		
D	A13X	18	PK	1661208C1																																																																																		
E	-	-	-	-																																																																																		
F	-	-	-	-																																																																																		
G@@	A13NA	14	PK	3566715C1																																																																																		
G##	A13NA	18	PK	1661208C1																																																																																		
H	A13AB	14	PK	1661209C1																																																																																		
J	-	-	-	-																																																																																		
K@	A13L	14	PK	1661209C1																																																																																		
K**	A13MA	18	PK	1661208C1																																																																																		
CONNECTOR 2007315C1 BODY LOCK 2007316C1				% W/ OUTSIDE TEMPERATURE SENSOR * W/ ENGINE BRAKE # N/ ENGINE BRAKE ## W/ ISX ENGINE @ W/ ETHER START ** W/ MANIFOLD PRESSURE GAUGE & MUTUAL EXCLUSIVE @ @ W/500K BAUD RATE																																																																																		
CHK	DATE	CHANGE	REV	REFERENCE	DRAWN	NAME																																																																																
MJVO	13MAR16	REVISED AND REDRAWN.	E	93408S	300371	CIRCUIT DIAGRAM, PAYSTAR																																																																																
					RELEASE NO.	DATE	PART NO.	SHEET																																																																														
					61879Y	17SEP09	AE08058092	057																																																																														

Figure 254 Connector Composites (491F / 492M / 494M)



13.68. CONNECTOR COMPOSITES (495M / 497M), P. 58

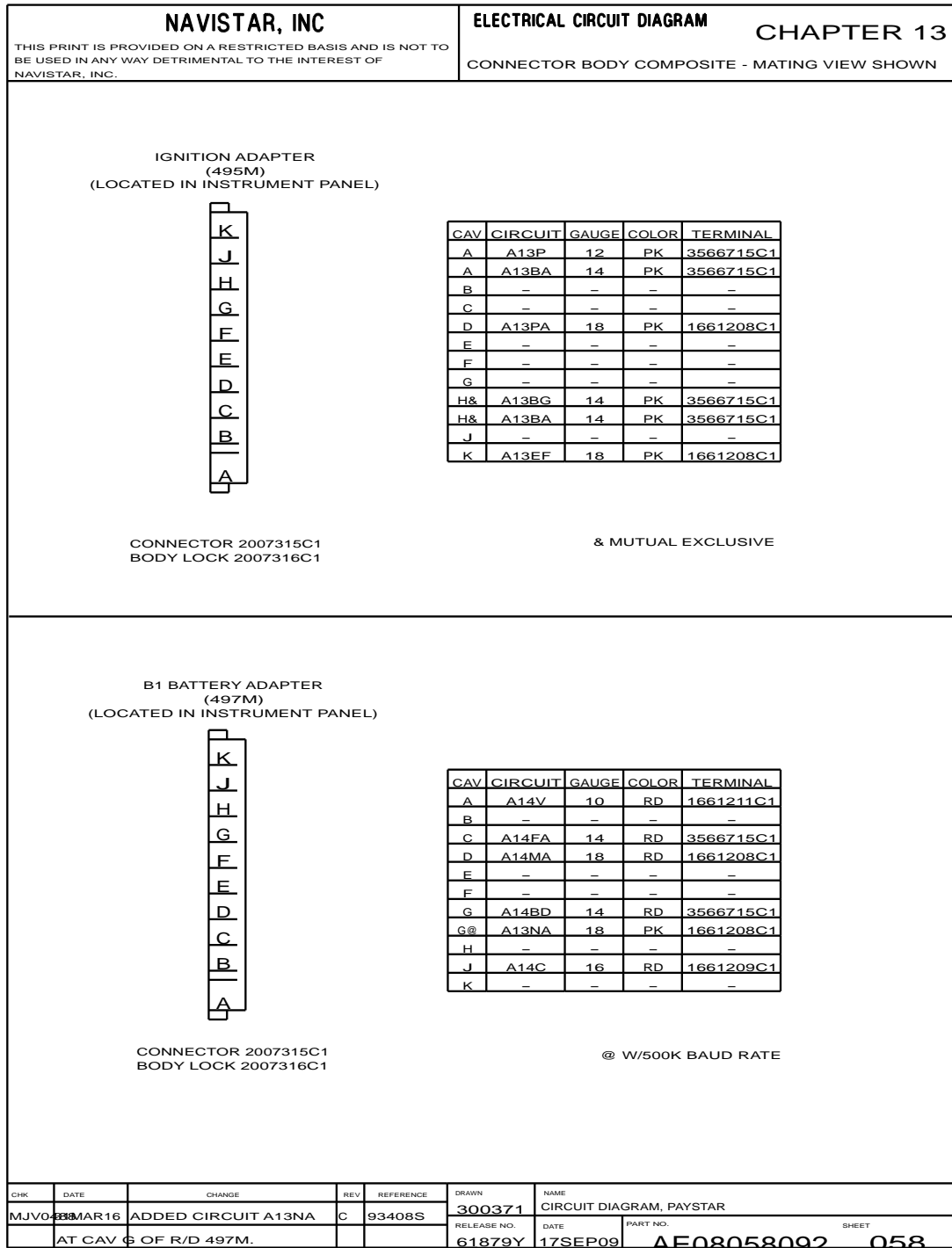


Figure 255 Connector Composites (495M / 497M)

13.69. CONNECTOR COMPOSITES (498M / 499M), P. 59

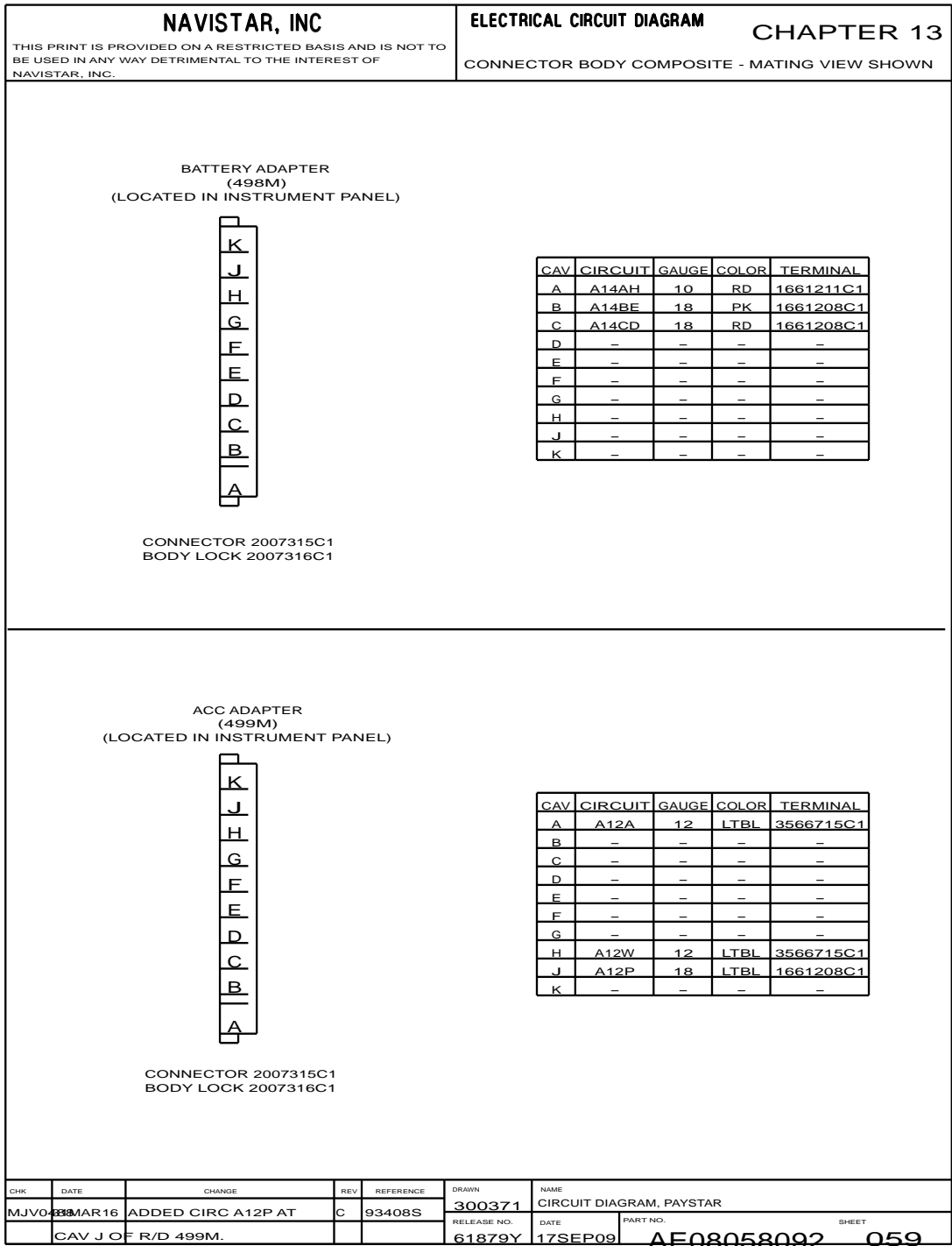


Figure 256 Connector Composites (498M / 499M)

13.70. CONNECTOR COMPOSITES (501M / 503M), P. 60

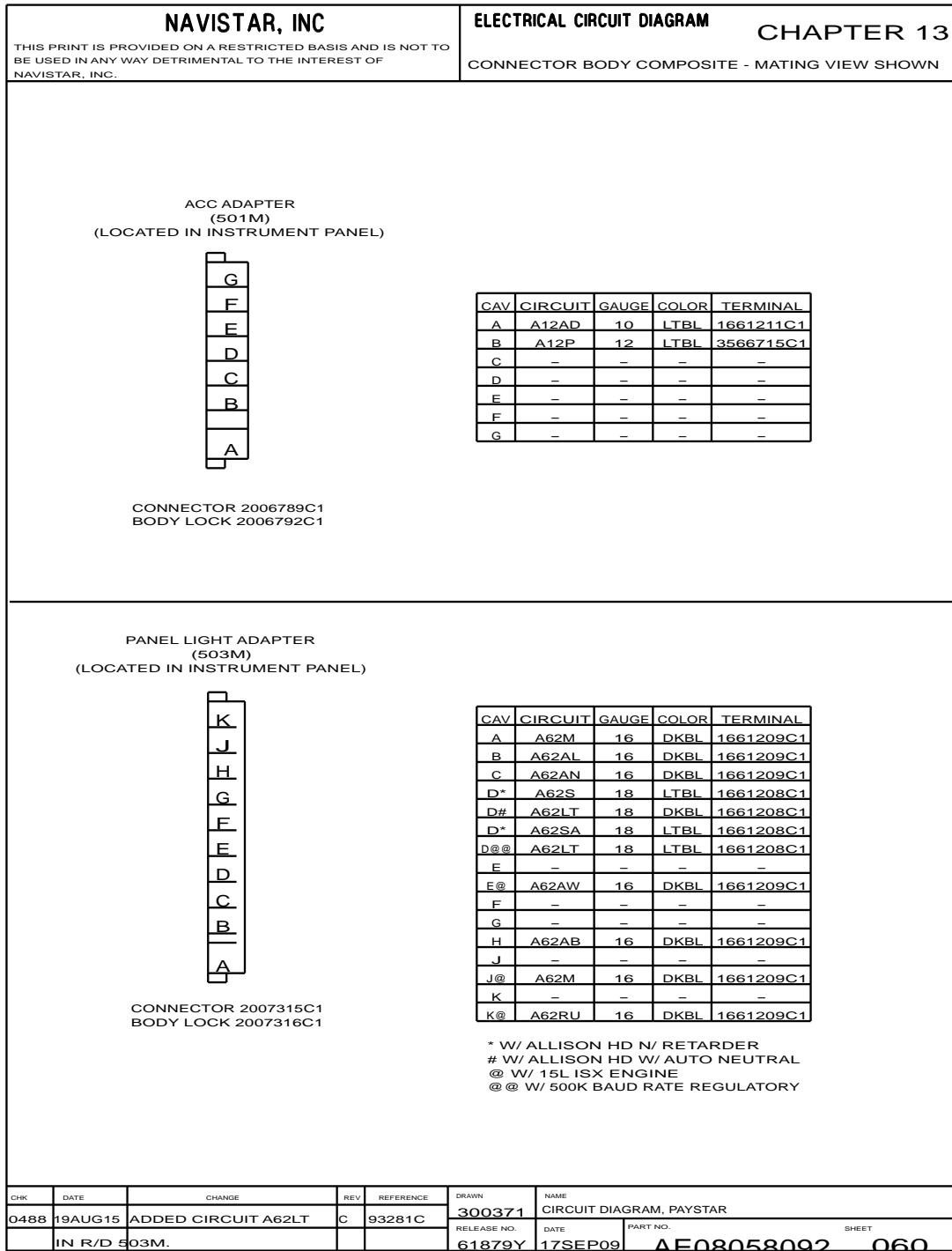



Figure 257 Connector Composites (501M / 503M)

13.71. CONNECTOR COMPOSITES (504M / 506M), P. 61

<b>NAVISTAR, INC</b>		<b>ELECTRICAL CIRCUIT DIAGRAM</b>		<b>CHAPTER 13</b>	
THIS PRINT IS PROVIDED ON A RESTRICTED BASIS AND IS NOT TO BE USED IN ANY WAY DETRIMENTAL TO THE INTEREST OF NAVISTAR, INC.		CONNECTOR BODY COMPOSITE - MATING VIEW SHOWN			

PANEL LIGHT ADAPTER  
(504M)  
(LOCATED IN INSTRUMENT PANEL)




CONNECTOR 2007315C1  
BODY LOCK 2007316C1

CAV	CIRCUIT	GAUGE	COLOR	TERMINAL
A	A62AE	16	DKBL	1661209C1
B*	A62MSM	16	DKBL	1661209C1
B@	A62EA	18	DKBL	1661208C1
B&	A92P	16	TN	1661209C1
C	A62AK	16	DKBL	1661209C1
C	A62AV	16	DKBL	1661209C1
D#	A62MSM	16	DKBL	1661209C1
D*	A62MSP	16	DKBL	1661209C1
D##	A62A	16	DKBL	1661209C1
E#	A62MSP	16	DKBL	1661209C1
E%	A62AW	16	DKBL	1661209C1
F	-	-	-	-
G	A62AJ	16	DKBL	1661209C1
G**	A62PLF	18	DKBL	1661208C1
H	A62U	16	DKBL	1661209C1
J	-	-	-	-
K	A62AY	16	DKBL	1661209C1

\* W/ ENGINE BRAKE  
# N/ ENGINE BRAKE  
@ W/ POWER ROAD RELAY  
% W/ SINGLE AXIS MIRROR  
& W/ EATON GEAR DISPLAY  
\*\* W/ BEACON LIGHT  
## W/ TRI-AXLE

PANEL GROUND ADAPTER  
(506M)  
(LOCATED IN INSTRUMENT PANEL)



CONNECTOR 2007315C1  
BODY LOCK 2007316C1

CAV	CIRCUIT	GAUGE	COLOR	TERMINAL
A	A11-GP	12	WH	3566715C1
B	A62-GMS	18	WH	1661208C1
C	A62-HMS	18	WH	1661208C1
D	A92MA	16	TN	1661209C1
E	-	-	-	-
F	A62GA	14	WH	1661209C1
G	-	-	-	-
H	A11-GAL	18	WH	1661208C1
J	-	-	-	-
K	A62-GAY	18	WH	1661208C1

CHK	DATE	CHANGE	REV	REFERENCE	DRAWN	NAME
0488	09SEP15	ADDED CIRC A62AK IN	D	93248U	300371	CIRCUIT DIAGRAM, PAYSTAR
	R/D 504M.				RELEASE NO. 61879Y	DATE 17SEP09
					PART NO. AE08058092	SHEET 061

Figure 258 Connector Composites (504M / 506M)

13.72. CONNECTOR COMPOSITES (509M / 511M / 512F), P. 62

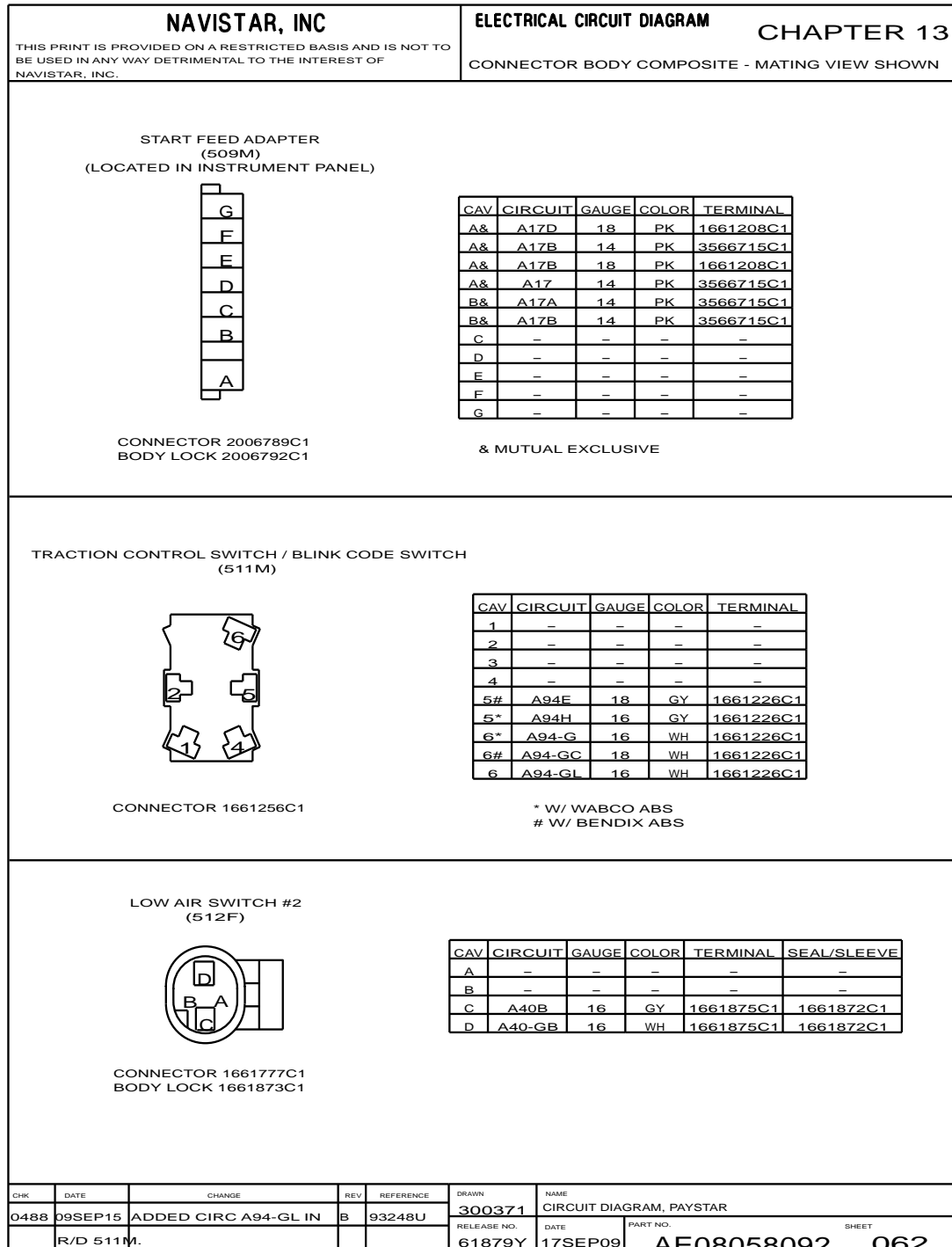


Figure 259 Connector Composites (509M / 511M / 512F)

13.73. CONNECTOR COMPOSITES (513M / 514M), P. 63

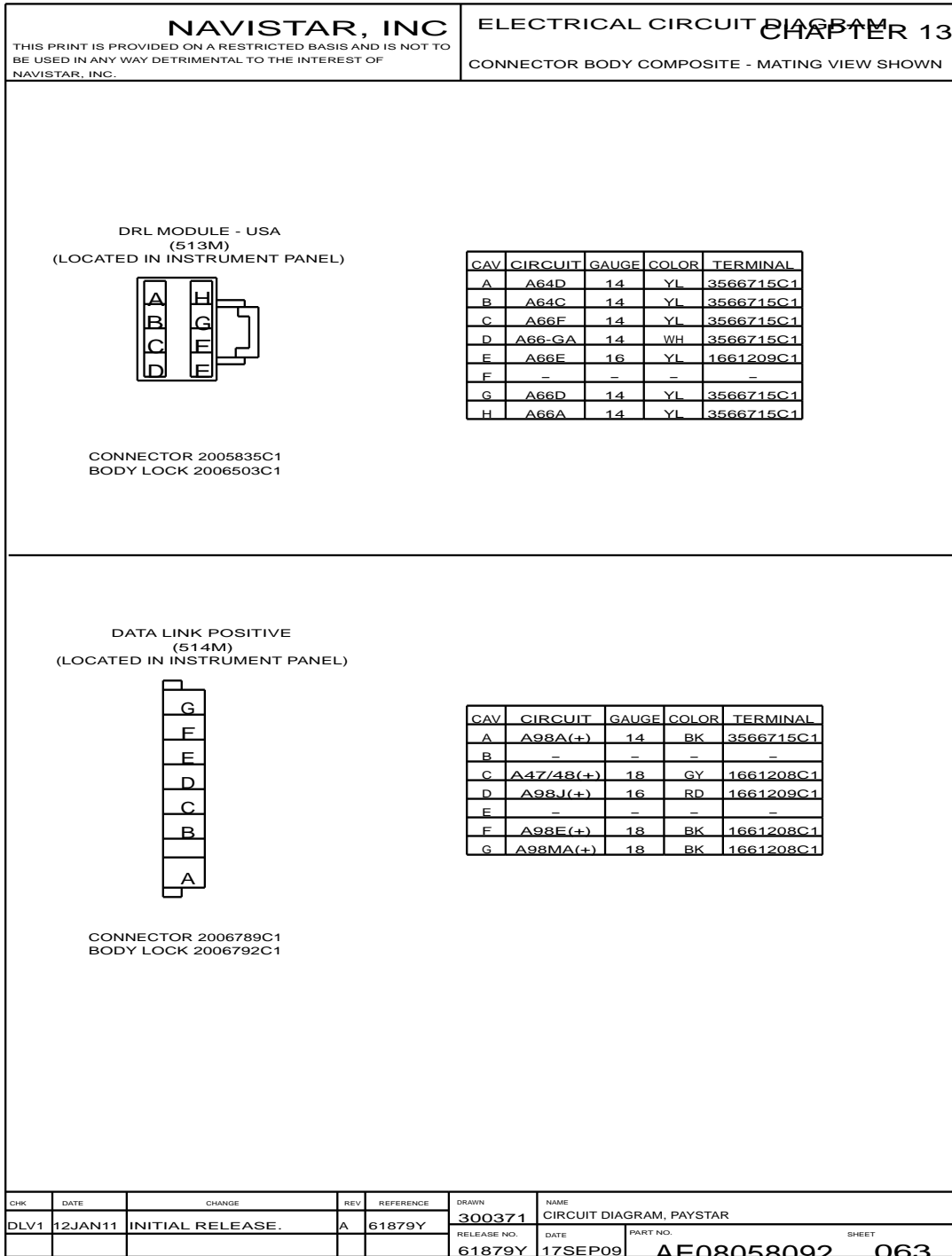


Figure 260 Connector Composites (513M / 514M)

13.74. CONNECTOR COMPOSITES (515M / 517M / 520 / 521), P. 64

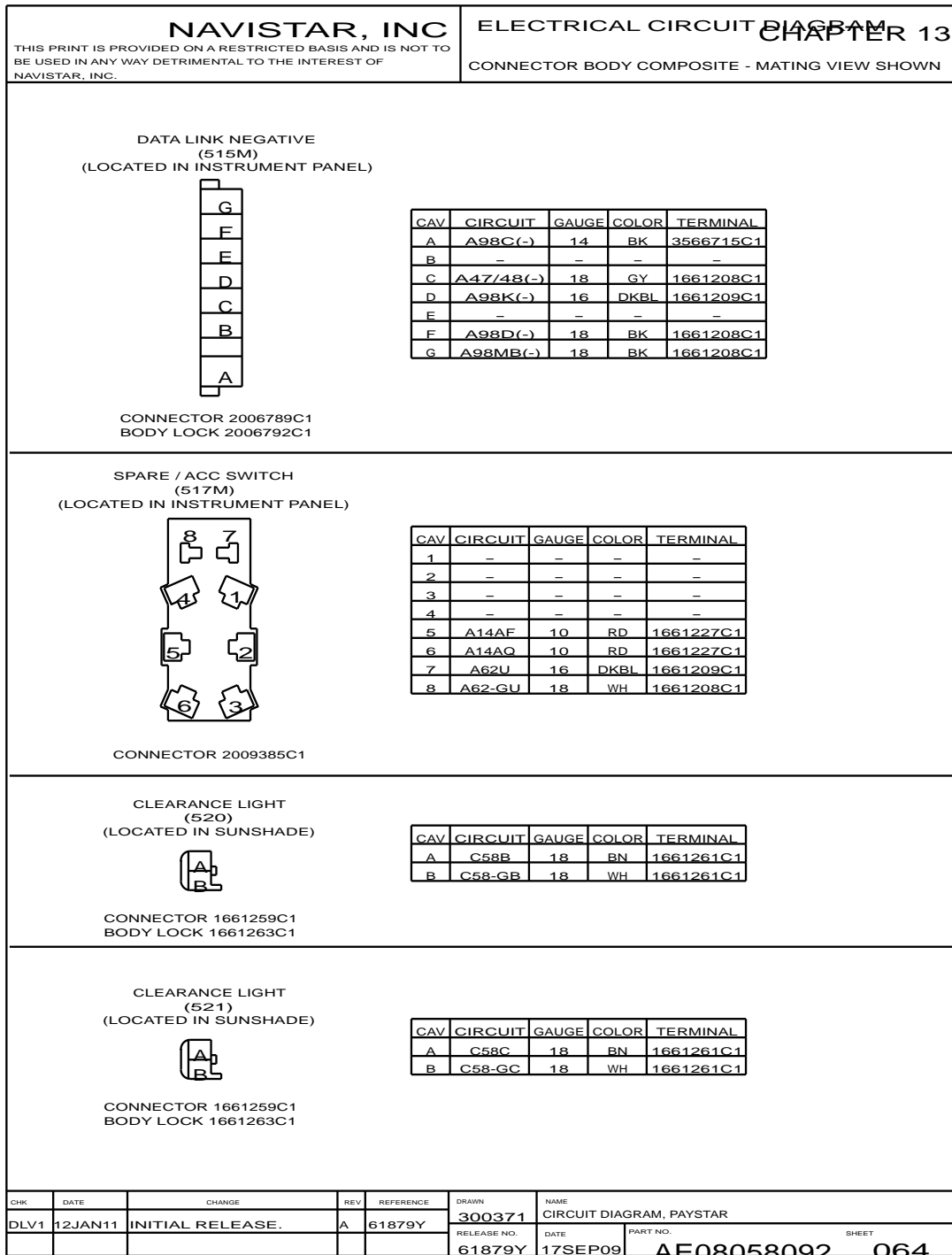


Figure 261 Connector Composites (515M / 517M / 520 / 521)

13.75. CONNECTOR COMPOSITES (522 / 523 / 524 / 528 / 529), P. 65

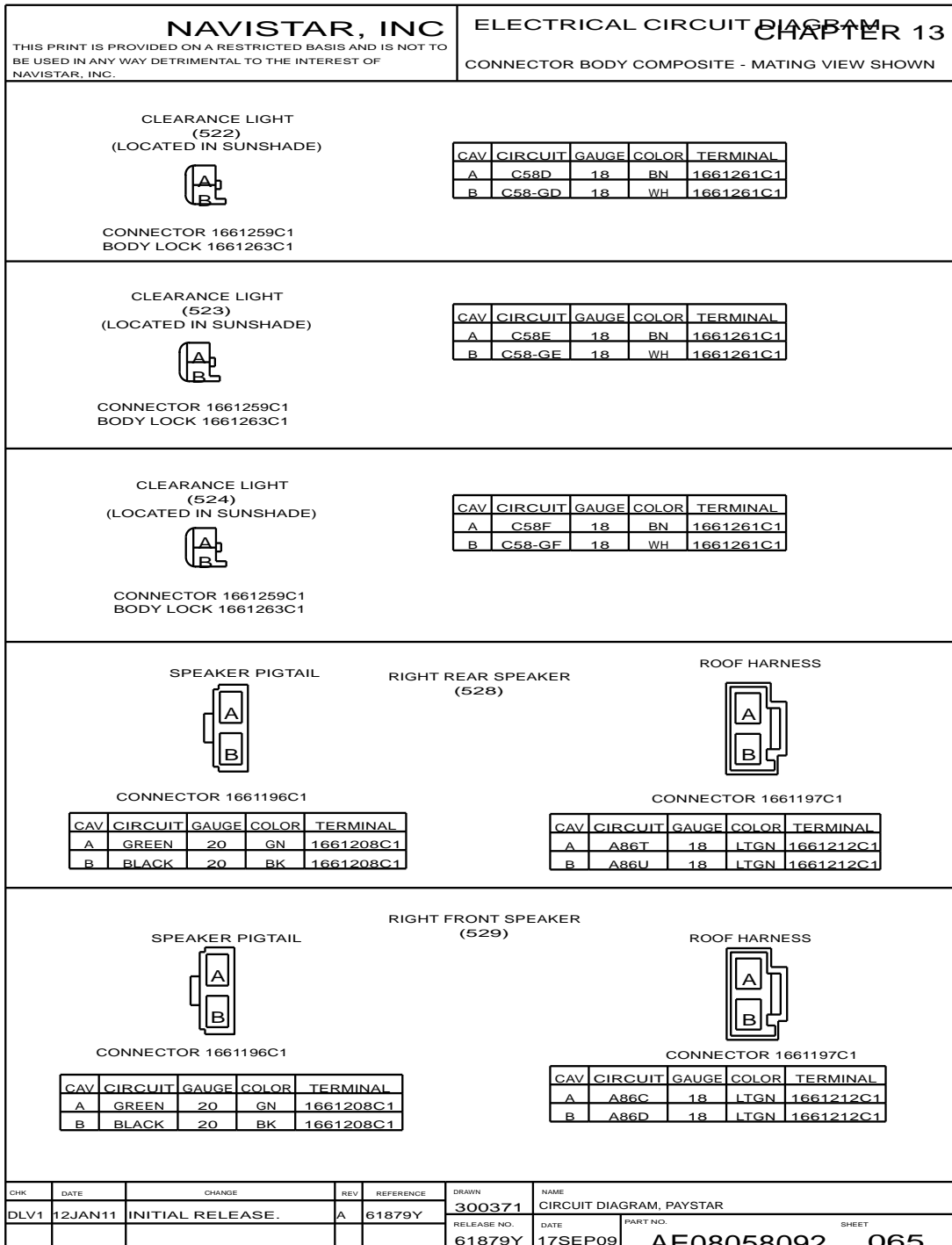


Figure 262 Connector Composites (522 / 523 / 524 / 528 / 529)



13.76. CONNECTOR COMPOSITES (530 / 531 / 562M / 600M), P. 66

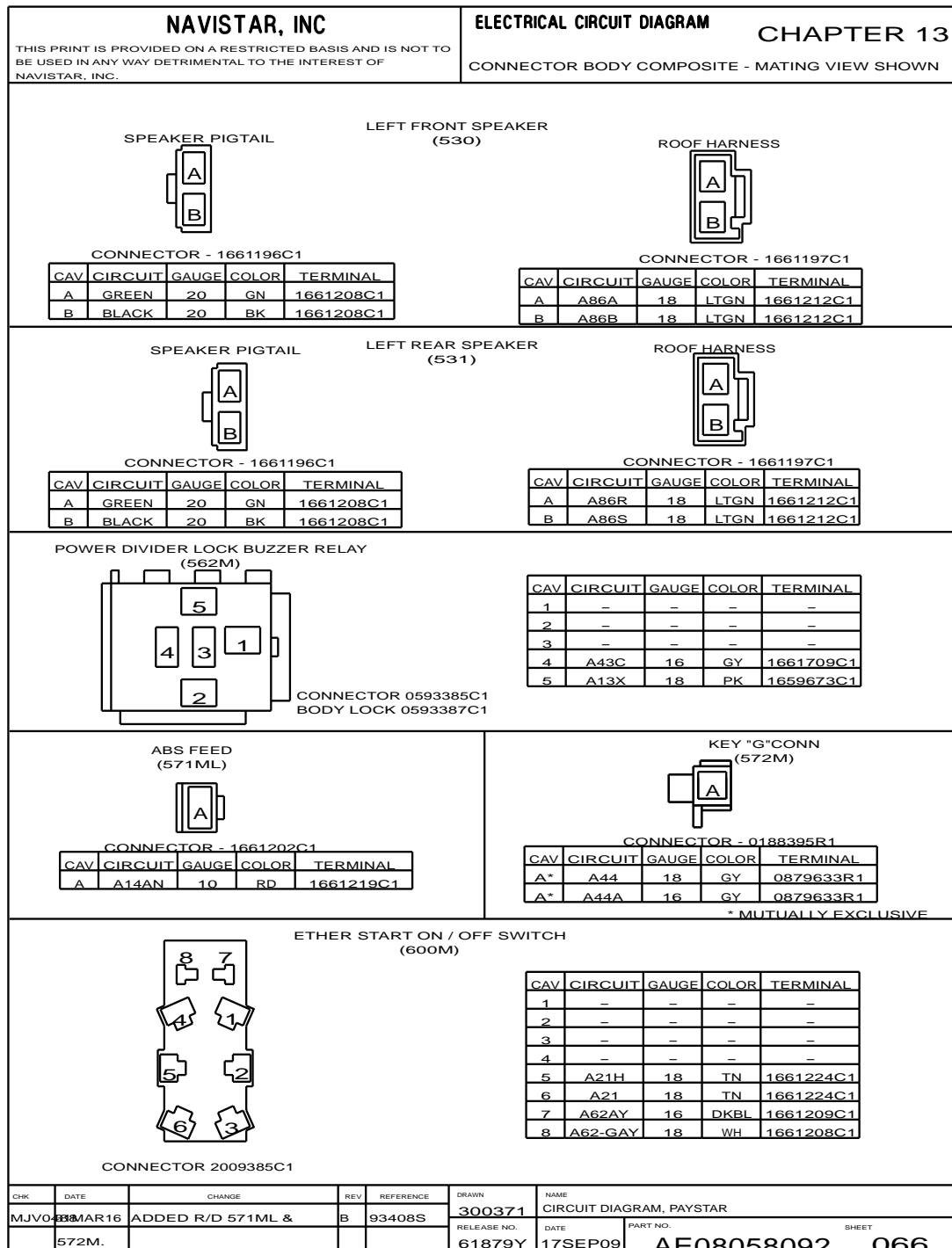


Figure 263 Connector Composites (530 / 531 / 562M / 600M)

13.77. CONNECTOR COMPOSITES (608 / 640 / 649M / 659M / 662M / 665B), P. 67

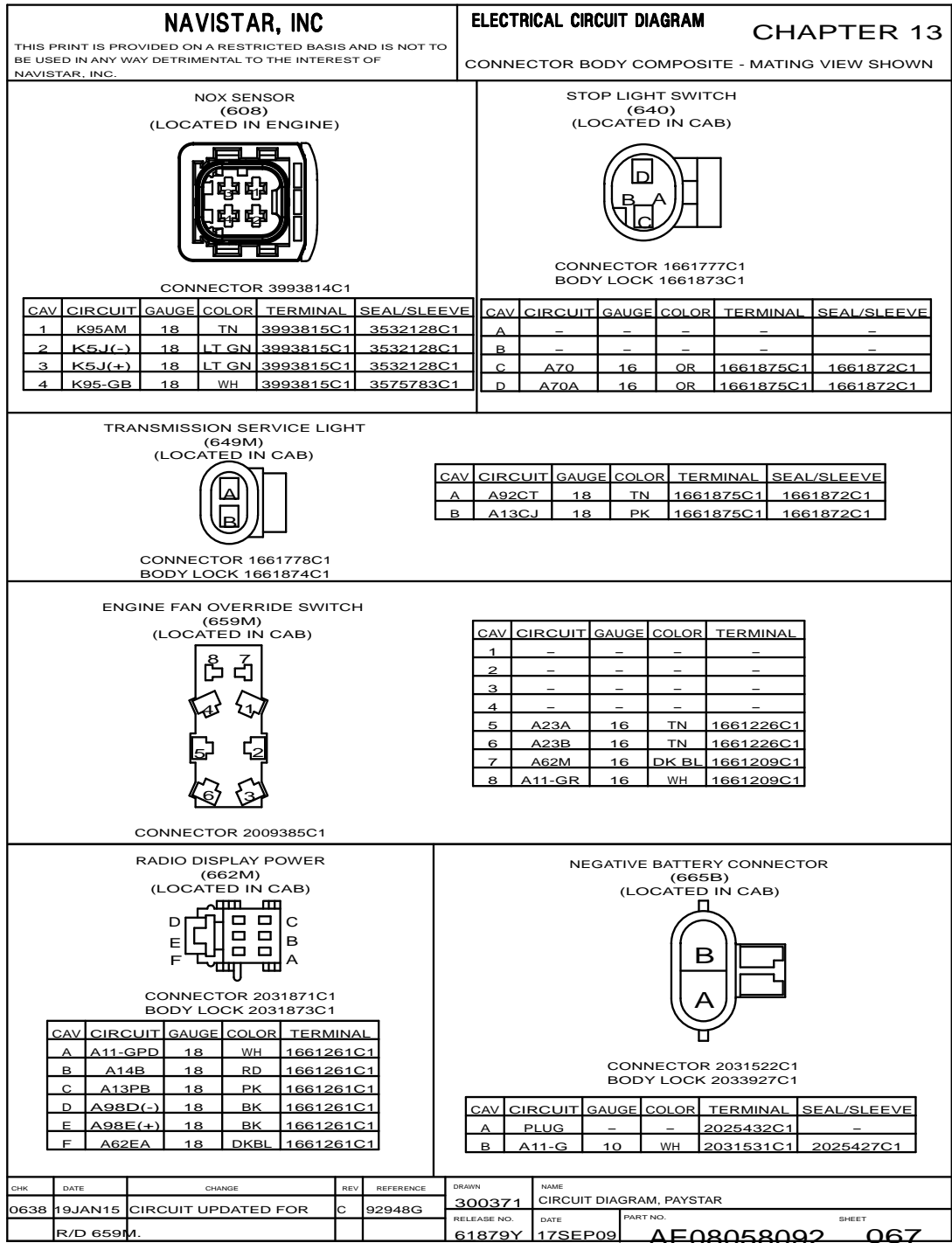


Figure 264 Connector Composites (608 / 640 / 649M / 659M / 662M / 665B)

13.78. CONNECTOR COMPOSITES (668M / 670 / 670A), P. 67A

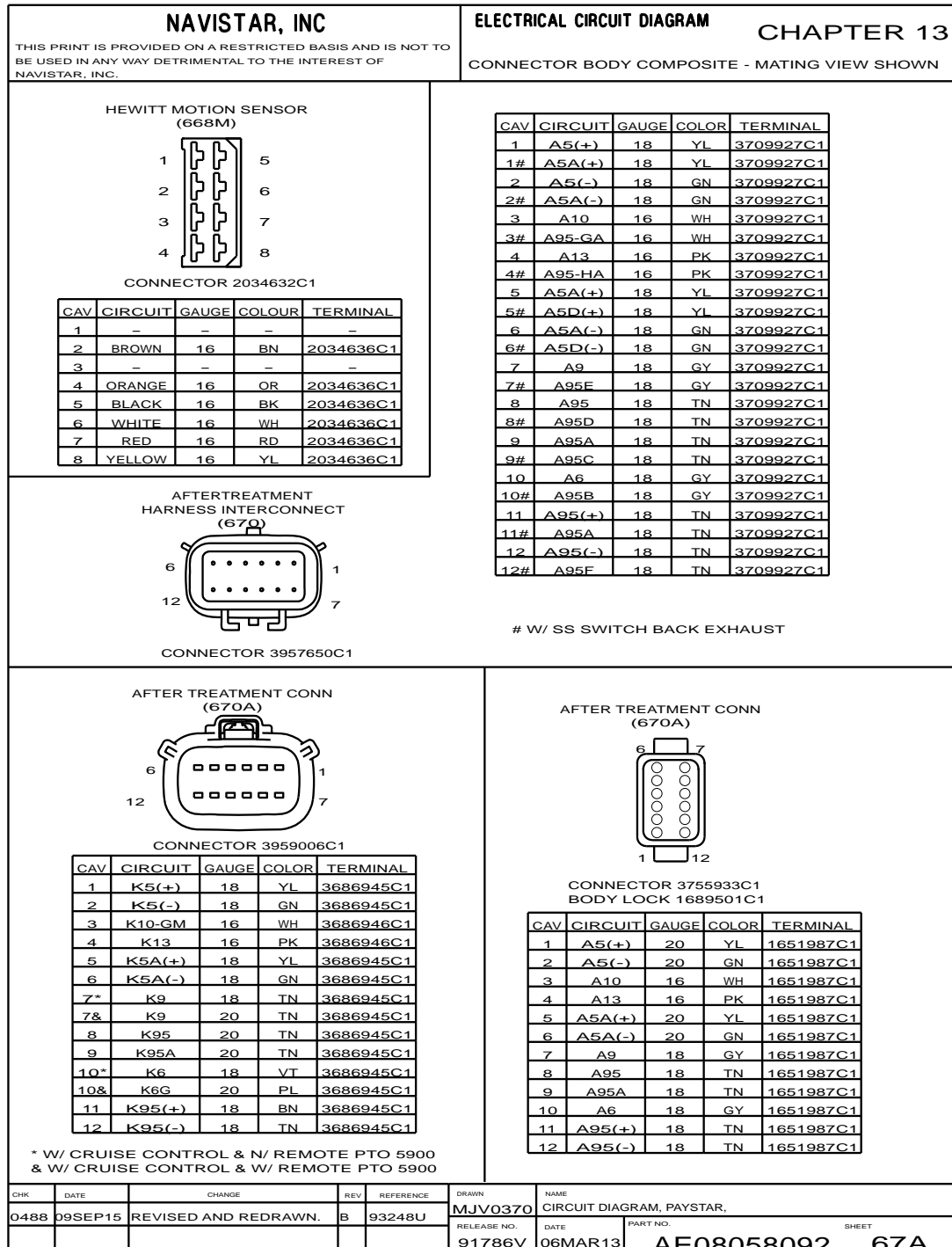
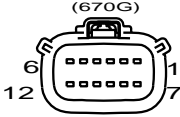
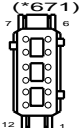
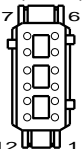
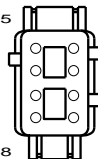


Figure 265 Connector Composites (668M / 670 / 670A)


13.79. CONNECTOR COMPOSITES (670G / \*671 / 671A / 672 / 673), P. 67B

<b>NAVISTAR, INC</b>				<b>ELECTRICAL CIRCUIT DIAGRAM</b>		<b>CHAPTER 13</b>			
THIS PRINT IS PROVIDED ON A RESTRICTED BASIS AND IS NOT TO BE USED IN ANY WAY DETRIMENTAL TO THE INTEREST OF NAVISTAR, INC.				CONNECTOR BODY COMPOSITE - MATING VIEW SHOWN					
AFTER TREATMENT CONN (670G) 				SCR SENSOR TABLE (*671) 					
CONNECTOR 3959006C1				CONNECTOR 3989896C1 BODY LOCK 3553460C1					
CAV	CIRCUIT	GAUGE	COLOUR	TERMINAL	CAV	CIRCUIT	GAUGE	COLOR	TERMINAL
1	K5(+)	18	YL	3686945C1	1	PLUG	-	-	-
2	K5(-)	18	LT GN	3686945C1	2	PLUG	-	-	-
3	K10-GM	16	WH	3686946C1	3	PLUG	-	-	-
4	K13	16	PK	3686946C1	4	PLUG	-	-	-
5	K5A(+)	18	YL	3686945C1	5	PLUG	-	-	-
6	K5A(-)	18	LT GN	3686945C1	6	PLUG	-	-	-
7	K9#	18	TN	3686945C1	7	A5B(+)	18	YL	3989895C1
7	K9@	20	TN	3686945C1	8	A5B(-)	18	GN	3989895C1
8	K95	20	TN	3686945C1	9	A10A	18	WH	3989895C1
9	K95A	20	TN	3686945C1	10	A13A	18	PK	3989895C1
10	K6#	18	VT	3686945C1	11	A5(+)	18	YL	3989895C1
10	K6G@	20	PK	3686945C1	12	A5(-)	18	GN	3989895C1
11	K95(+)	18	BN	3686945C1					
12	K95(-)	18	TN	3686945C1					

SCR JUMPER CONN (671A) 				DPF SENSOR TABLE (672) 					
CONNECTOR 3989896C1 BODY LOCK 3553460C1				CONNECTOR 3989894C1 BODY LOCK 3539144C1					
CAV	CIRCUIT	GAUGE	COLOR	TERMINAL	CAV	CIRCUIT	GAUGE	COLOR	TERMINAL
1 TO 6	PLUG	-	-	3527276C1	1	A5C(+)	18	YL	3989895C1
7	A5C(+)	18	YL	3989895C1	1#	A5B(+)	18	YL	3989895C1
8	A5C(-)	18	GN	3989895C1	2	A5C(-)	18	GN	3989895C1
9	A95-GB	16	WH	3555249C1	2#	A5B(-)	18	GN	3989895C1
10	A95HB	16	PK	3555249C1	3	A10B	18	WH	3989895C1
11	A5A(+)	18	YL	3989895C1	3#	A95-GC	18	WH	3989895C1
12	A5A(-)	18	GN	3989895C1	4	A13B	18	PK	3989895C1

DPF DOSER (673) 				# W/ SS SWITCH BACK EXHAUST					
CONNECTOR 3690364C1				# W/ SS SWITCH BACK EXHAUST					
CAV	CIRCUIT	GAUGE	COLOR	TERMINAL	SEAL/SLEEVE				
1	A95(+)	18	TN	3689960C1	3623615C1				
1#	A95A	18	TN	3689960C1	3623615C1				
2	A95(-)	18	TN	3689960C1	3623615C1				
2#	A95F	18	TN	3689960C1	3623615C1				

CHK	DATE	CHANGE	REV	REFERENCE	DRAWN	NAME		
0488	09SEP15	REVISED AND REDRAWN.	B	93248U	MJV0088	CIRCUIT DIAGRAM, PAYSTAR,		
					RELEASE NO.	DATE	PART NO.	SHEET
					91786V	17APR13	AE08058092	67B

Figure 266 Connector Composites (670G / \*671 / 671A / 672 / 673)

13.80. CONNECTOR COMPOSITES (674), P. 67C

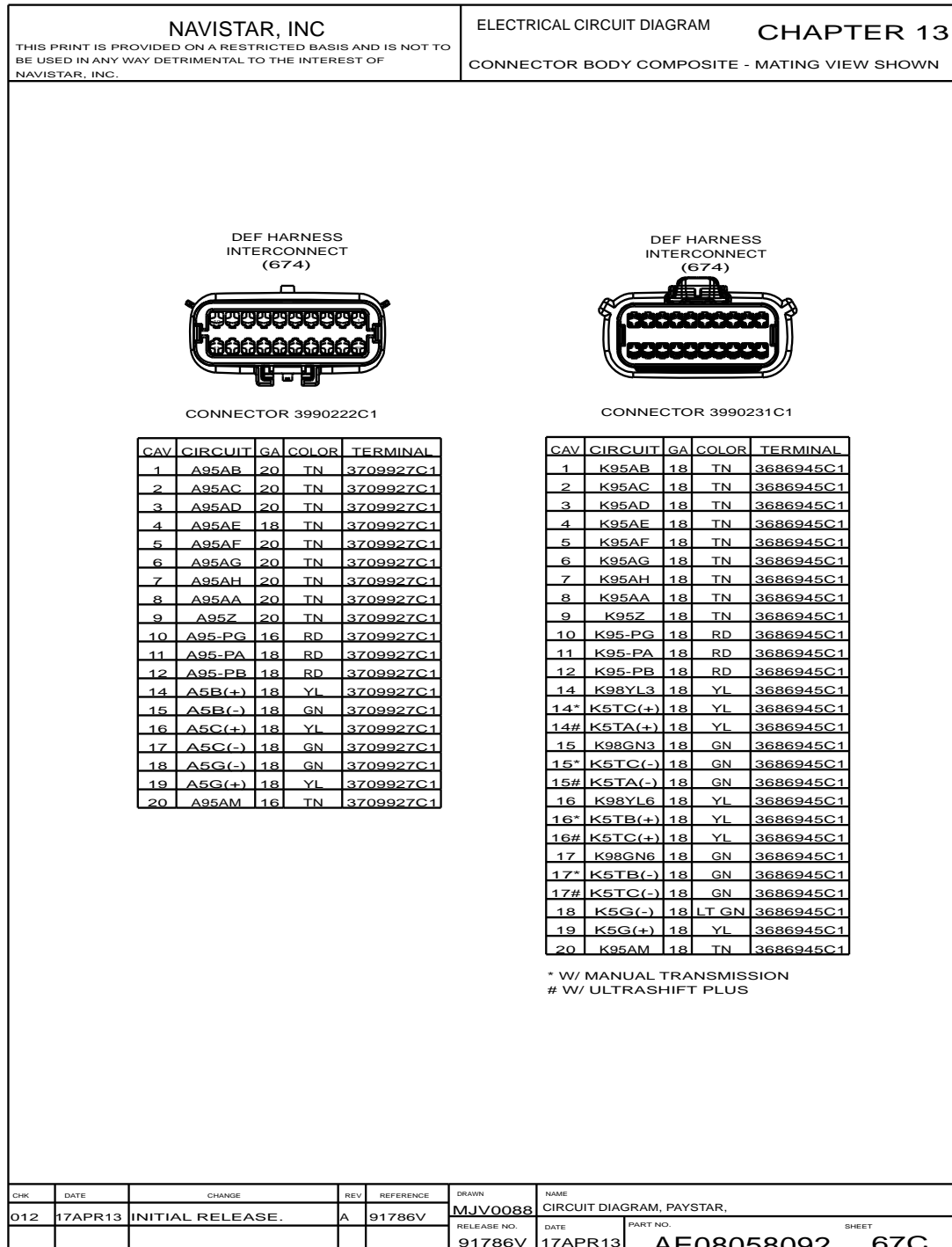


Figure 267 Connector Composites (674)

13.81. CONNECTOR COMPOSITES (674D / 674E / 675 / 676), P. 67D

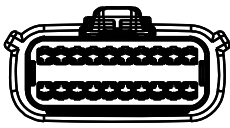
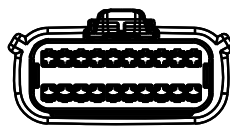


<b>NAVISTAR, INC</b> <small>THIS PRINT IS PROVIDED ON A RESTRICTED BASIS AND IS NOT TO BE USED IN ANY WAY DETRIMENTAL TO THE INTEREST OF NAVISTAR, INC.</small>				ELECTRICAL CIRCUIT DIAGRAM <b>CHAPTER 13</b> CONNECTOR BODY COMPOSITE - MATING VIEW SHOWN	
<b>DEF TANK HARNESS CONNECTOR (674D)</b> 			<b>DEF TANK (674E)</b> 		
CONNECTOR 3990231C1			CONNECTOR 3990231C1		
<b>CAV</b>	<b>CIRCUIT</b>	<b>GAUGE</b>	<b>COLOR</b>	<b>TERMINAL</b>	
1	K95D	20	TN	3686945C1	1
2	K95E	20	TN	3686945C1	2
3	K95F	20	TN	3686945C1	3
4	K10-GL	16	WH	3686946C1	4
5	K95G	20	TN	3686945C1	5
6	K95-GB	16	TN	3686946C1	6
7	K95H&	20	TN	3686945C1	7
7	K95H@	20	TN	3686945C1	7
8	K95J&	16	VT	3686946C1	8
8	K6E@	20	PL	3686945C1	8
9	K95K	20	TN	3686945C1	9
10	K95A1	20	TN	3686945C1	10
11	K95M	16	TN	3686946C1	11
12	K95B	20	TN	3686945C1	12
13	K95C	20	TN	3686945C1	13
14	K14	16	RD	3686946C1	14
15	K13A	16	PK	3686946C1	15
16	K13E	16	PK	3686946C1	16
17	K95-GA	20	TN	3686945C1	17
18	K5(-)	18	GN	3686945C1	18
19	K5(+)	18	YL	3686945C1	19
20	K14A	16	RD	3686946C1	20
& W/ CRUISE CONTROL & N/ REMOTE PTO 5900 @ W/ CRUISE CONTROL & W/ REMOTE PTO 5900					
<b>BACKFLOW HEATER (675)</b> 			<b>PRESSURE HEATER (676)</b> 		
CONNECTOR 3854665C91			CONNECTOR 3854666C91		
<b>CAV</b>	<b>CIRCUIT</b>	<b>GAUGE</b>	<b>COLOR</b>	<b>TERMINAL</b>	
1	A95AP	16	TN	1680205C1	1
*1	A95AA	16	TN	1680205C1	*1
2	A95S	18	TN	1680205C1	2
*2	A95MA	16	TN	1680205C1	*2
* W/ 2010 SCR 13L ENG					
<b>CHK</b>	<b>DATE</b>	<b>CHANGE</b>	<b>REV</b>	<b>REFERENCE</b>	<b>DRAWN</b>
012	17APR13	INITIAL RELEASE.	A	91786V	MJV0088
					<b>NAME</b>
					CIRCUIT DIAGRAM, PAYSTAR,
			<b>RELEASE NO.</b>	<b>DATE</b>	<b>PART NO.</b>
			91786V	17APR13	AE08058092
					<b>SHEET</b>
					67D

Figure 268 Connector Composites (674D / 674E / 675 / 676)

13.82. CONNECTOR COMPOSITES (677 / 678 / 679), P. 67E

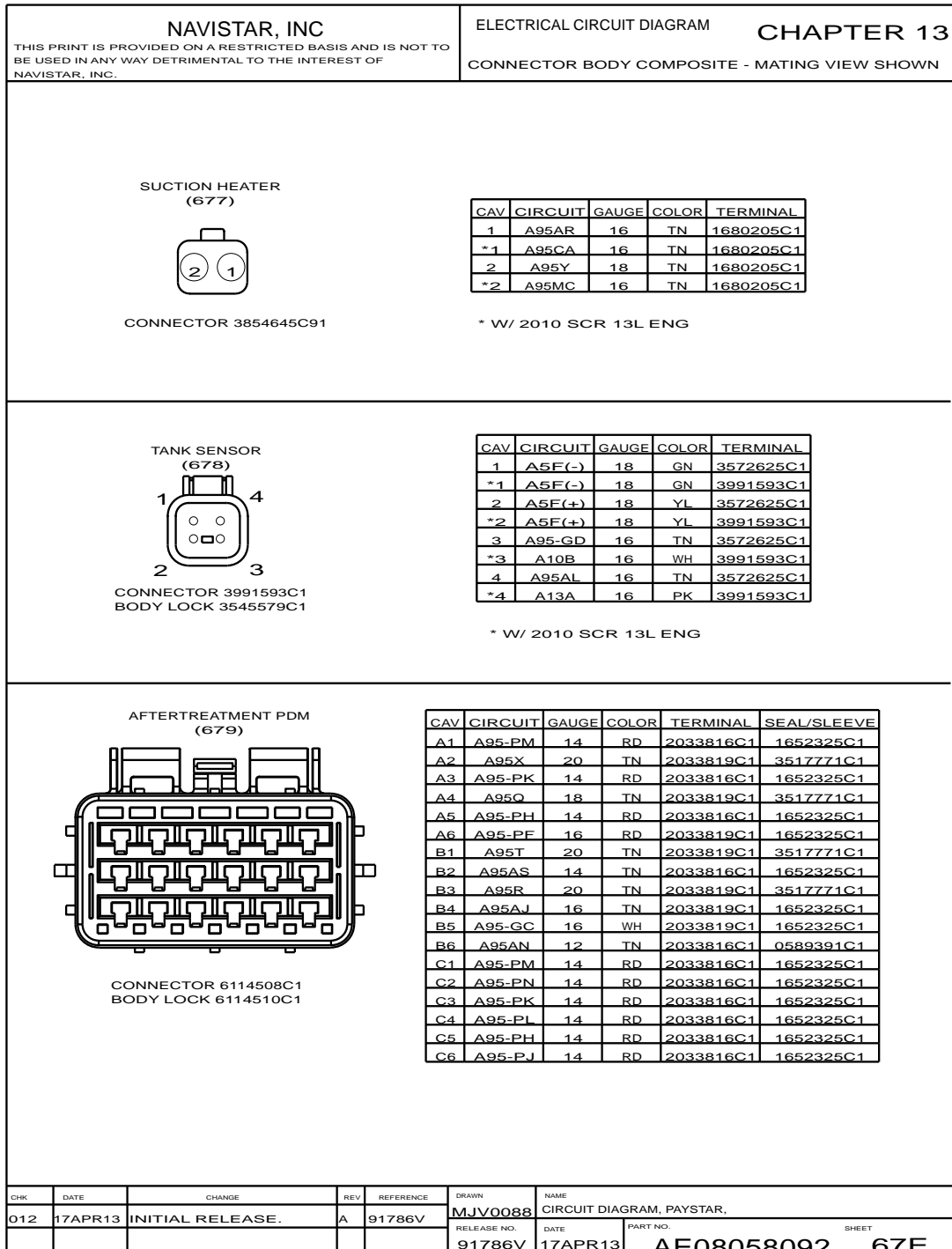


Figure 269 Connector Composites (677 / 678 / 679)

13.83. CONNECTOR COMPOSITES (\*679 / 680), P. 67F

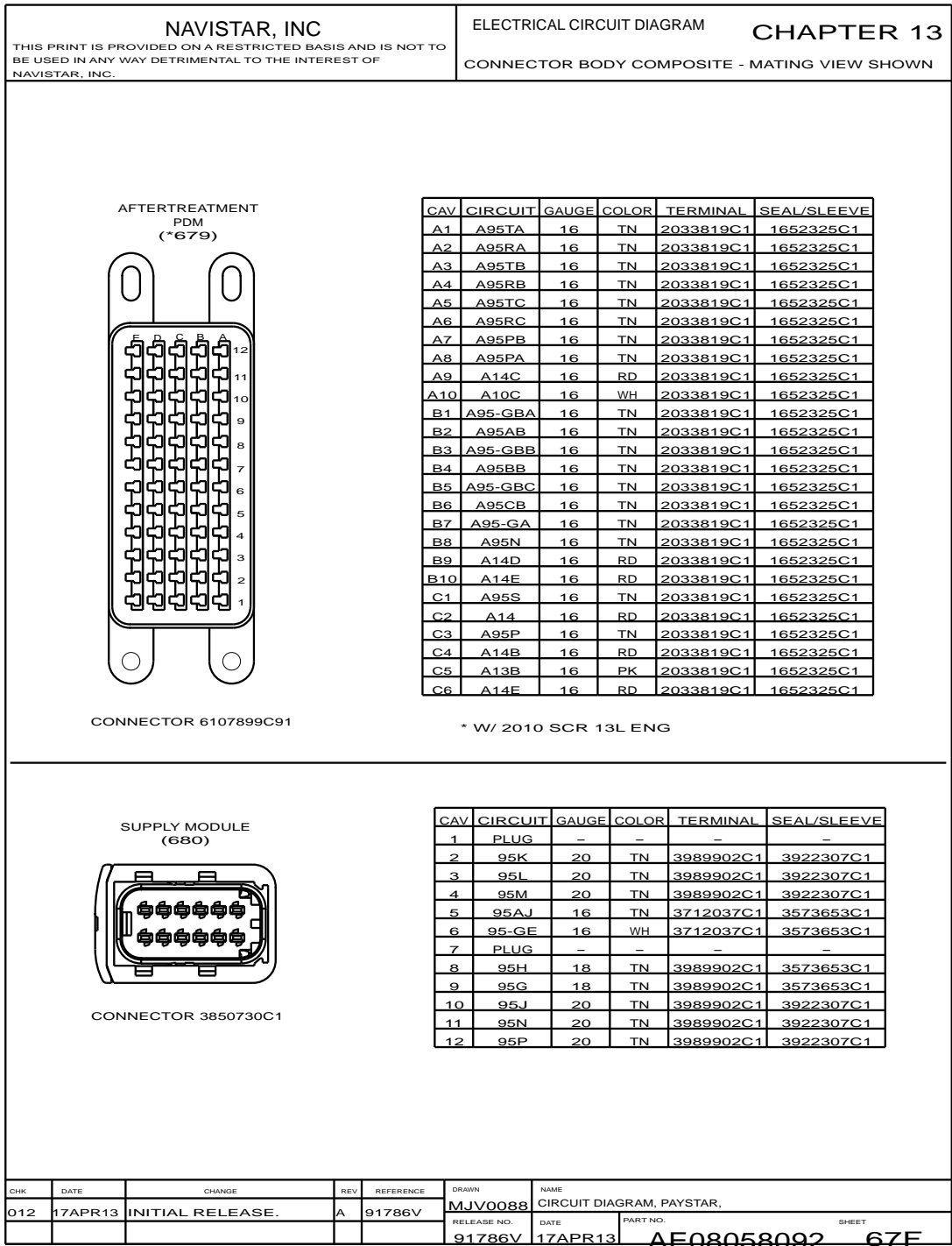


Figure 270 Connector Composites (\*679 / 680)



13.84. CONNECTOR COMPOSITES (\*680 / \*681), P. 67G

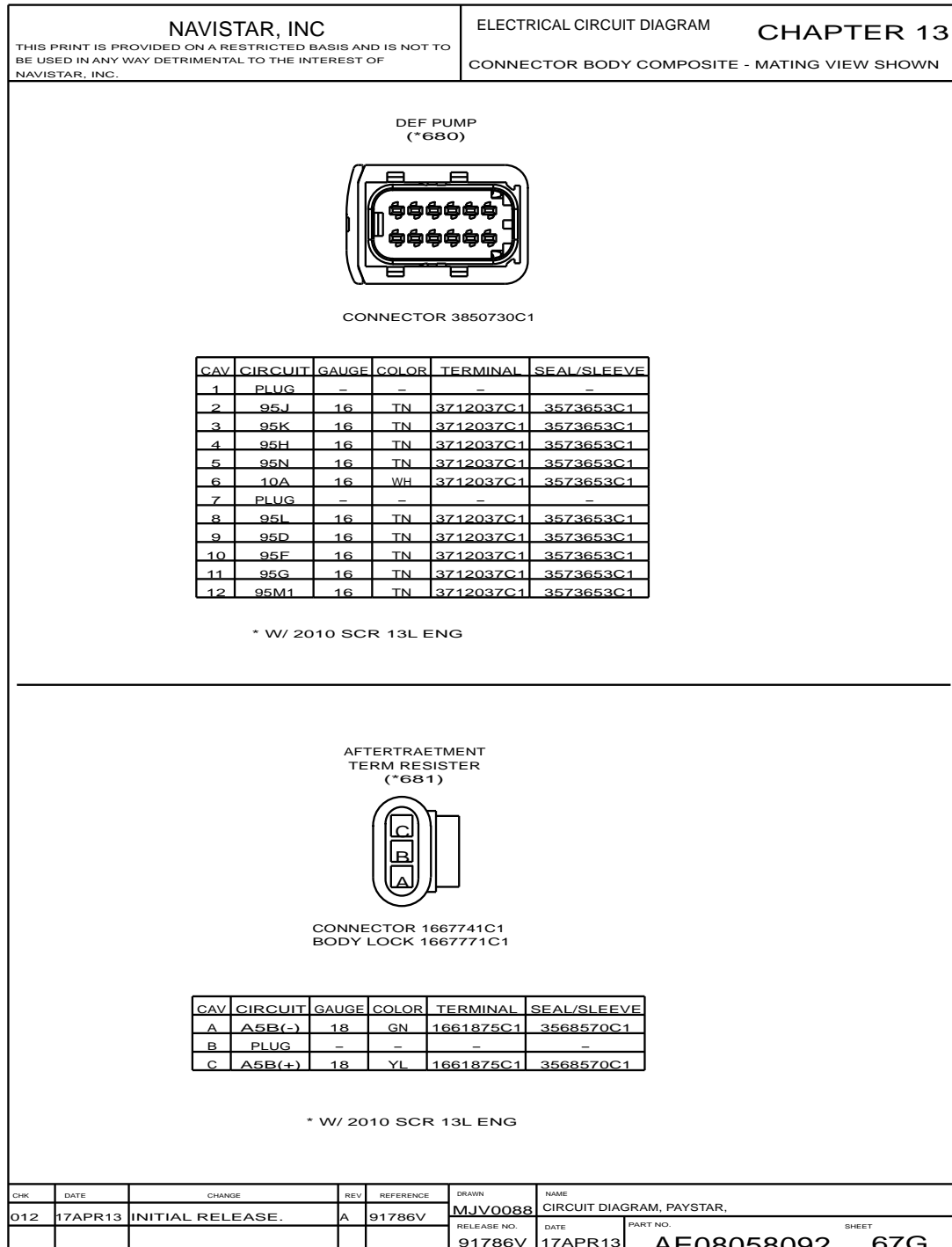


Figure 271 Connector Composites (\*680 / \*681)

13.85. CONNECTOR COMPOSITES (685), P. 67H

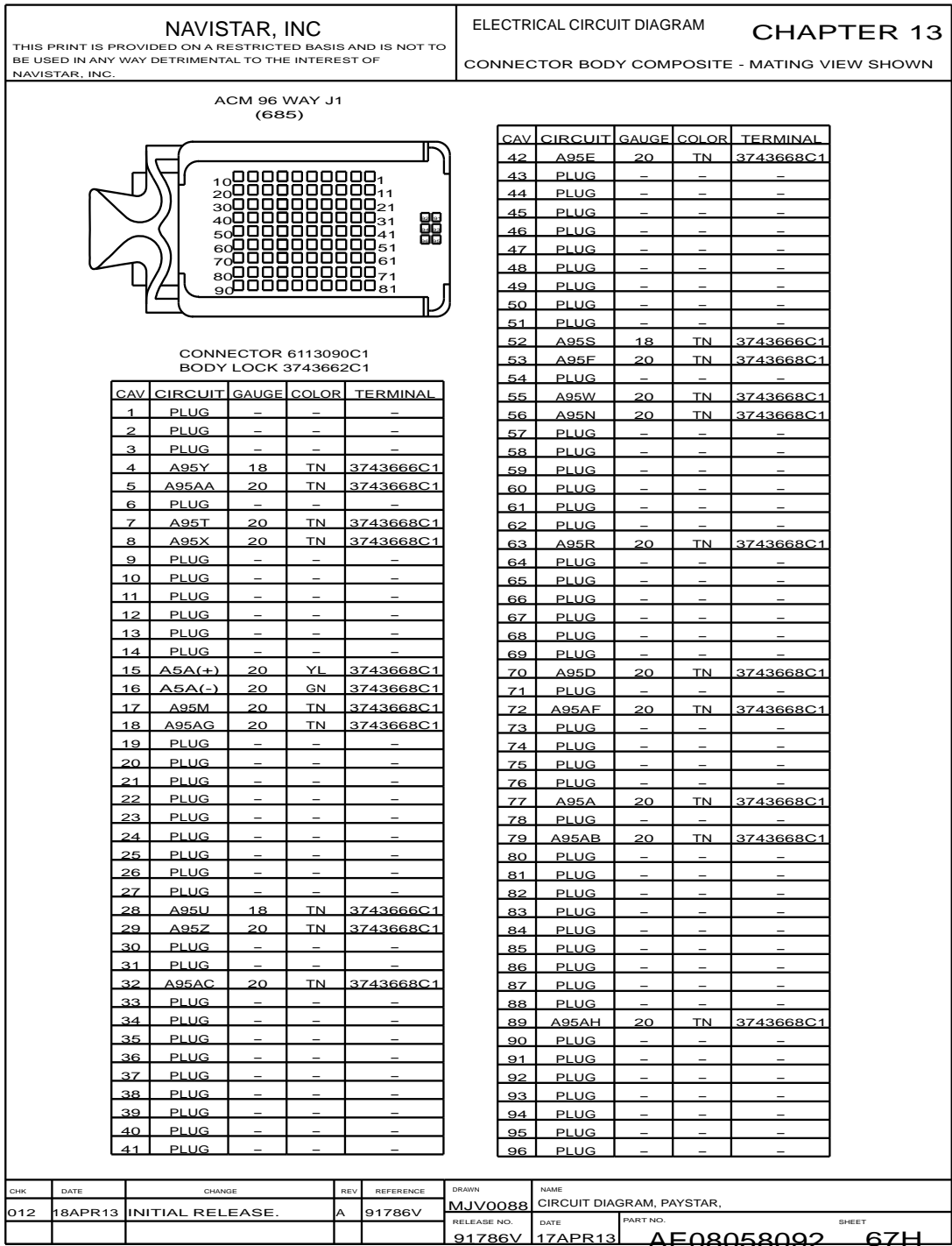


Figure 272 Connector Composites (685)

13.86. CONNECTOR COMPOSITES (686 / 687), P. 671

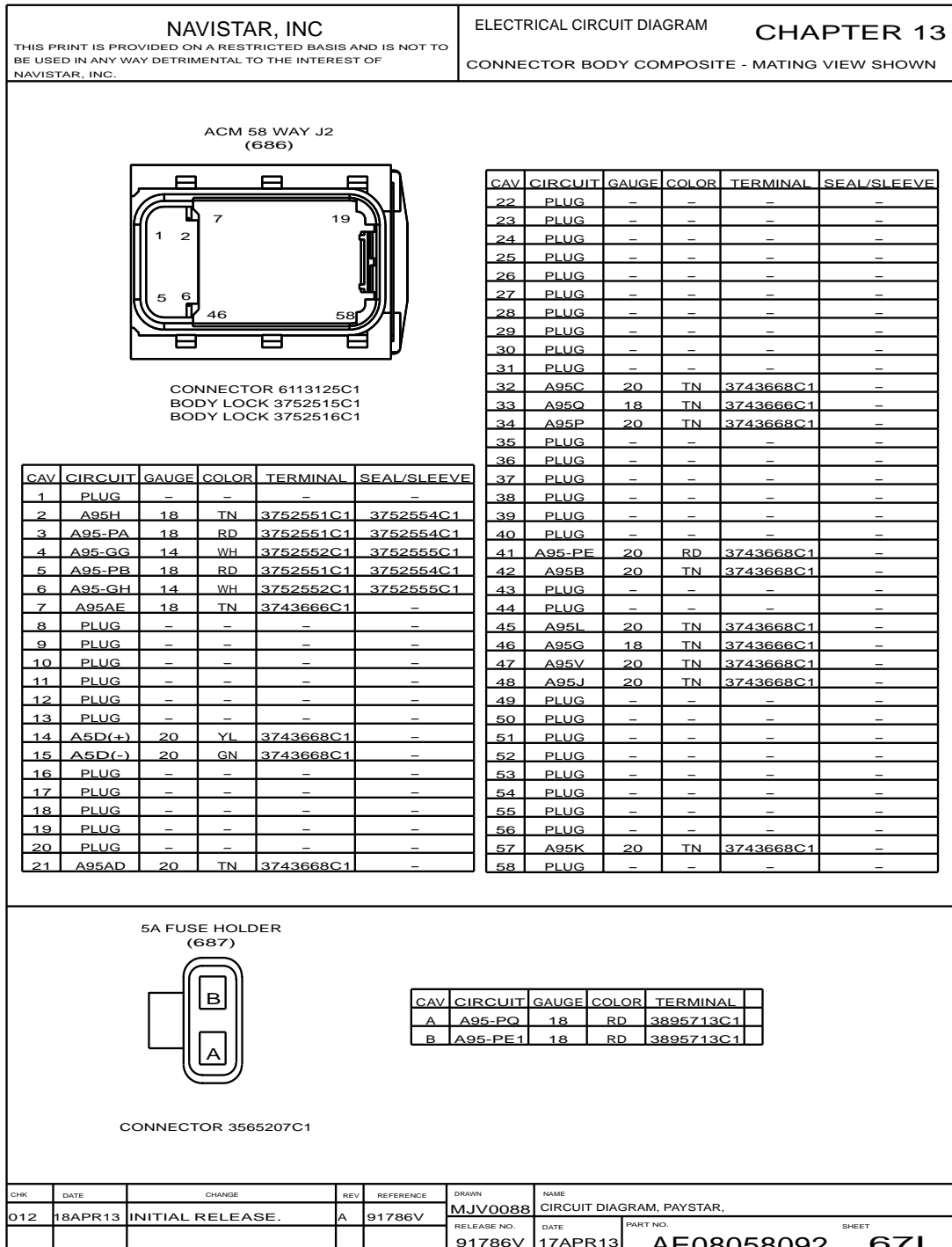


Figure 273 Connector Composites (686 / 687)

13.87. CONNECTOR COMPOSITES (690 / 691 / 694M), P. 68

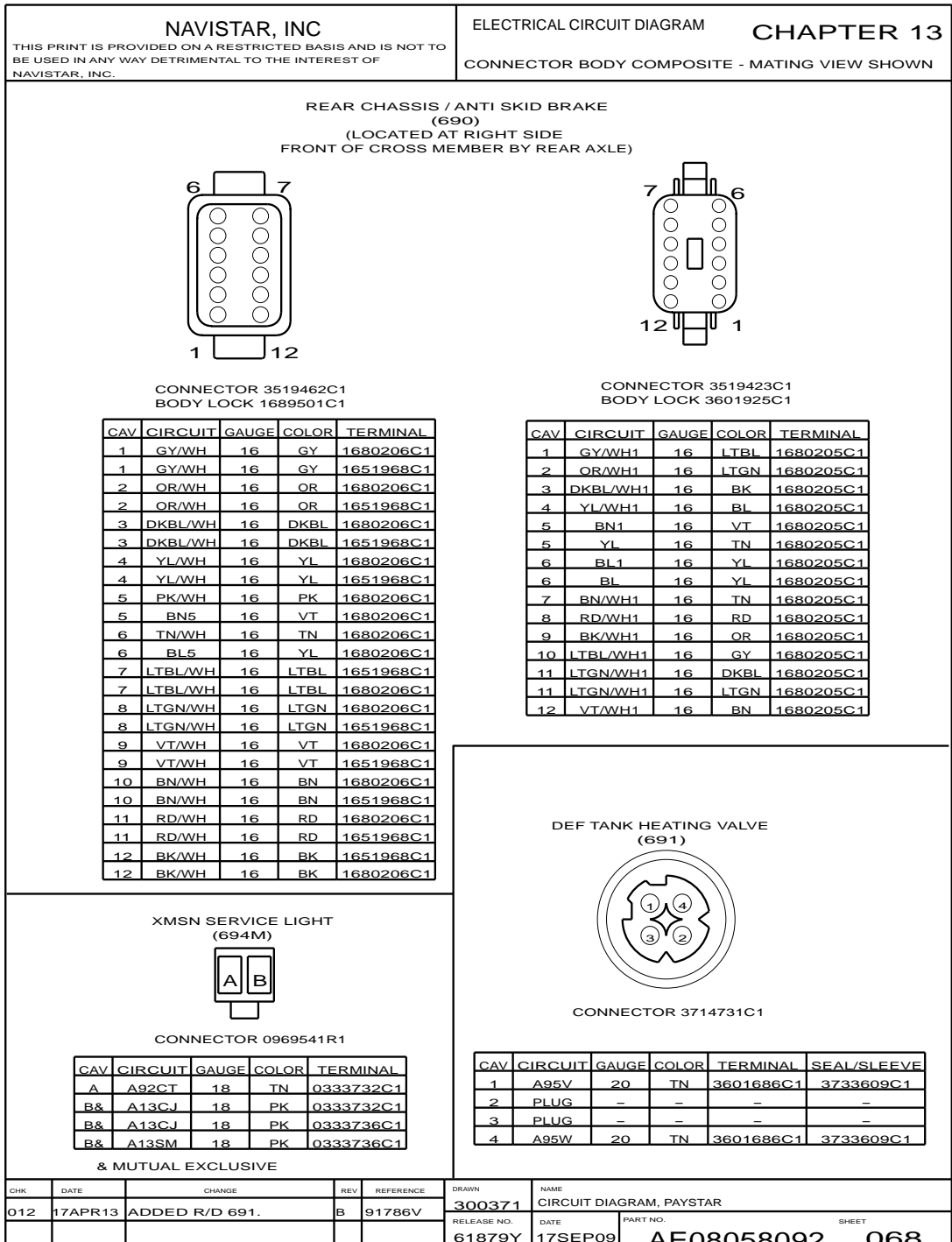


Figure 274 Connector Composites (690 / 691 / 694M)

13.88. CONNECTOR COMPOSITES (695F / 723M / 741F / 742F / 753), P. 69

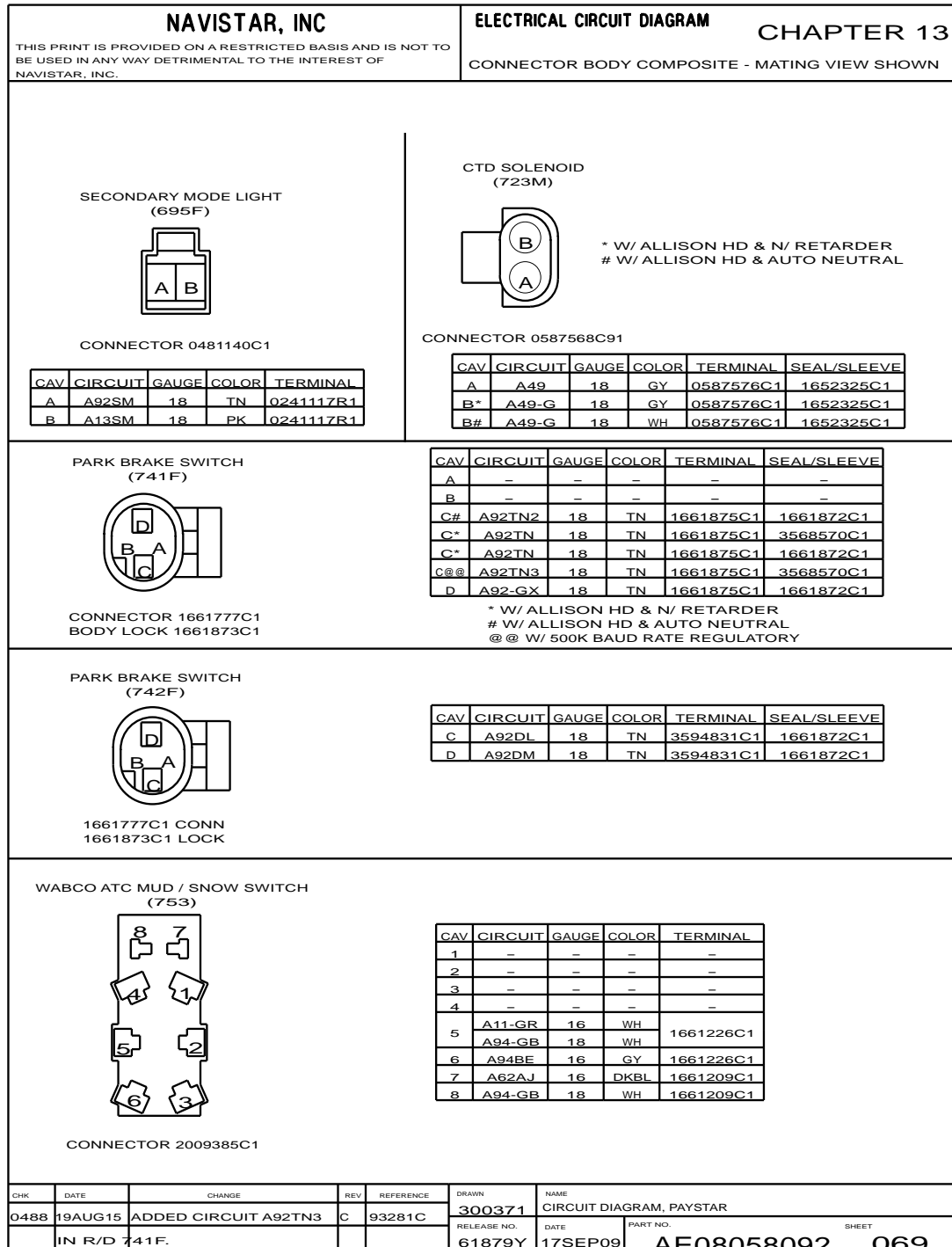


Figure 275 Connector Composites (695F / 723M / 741F / 742F / 753)

13.89. CONNECTOR COMPOSITES (766 / 768 / 769), P. 70

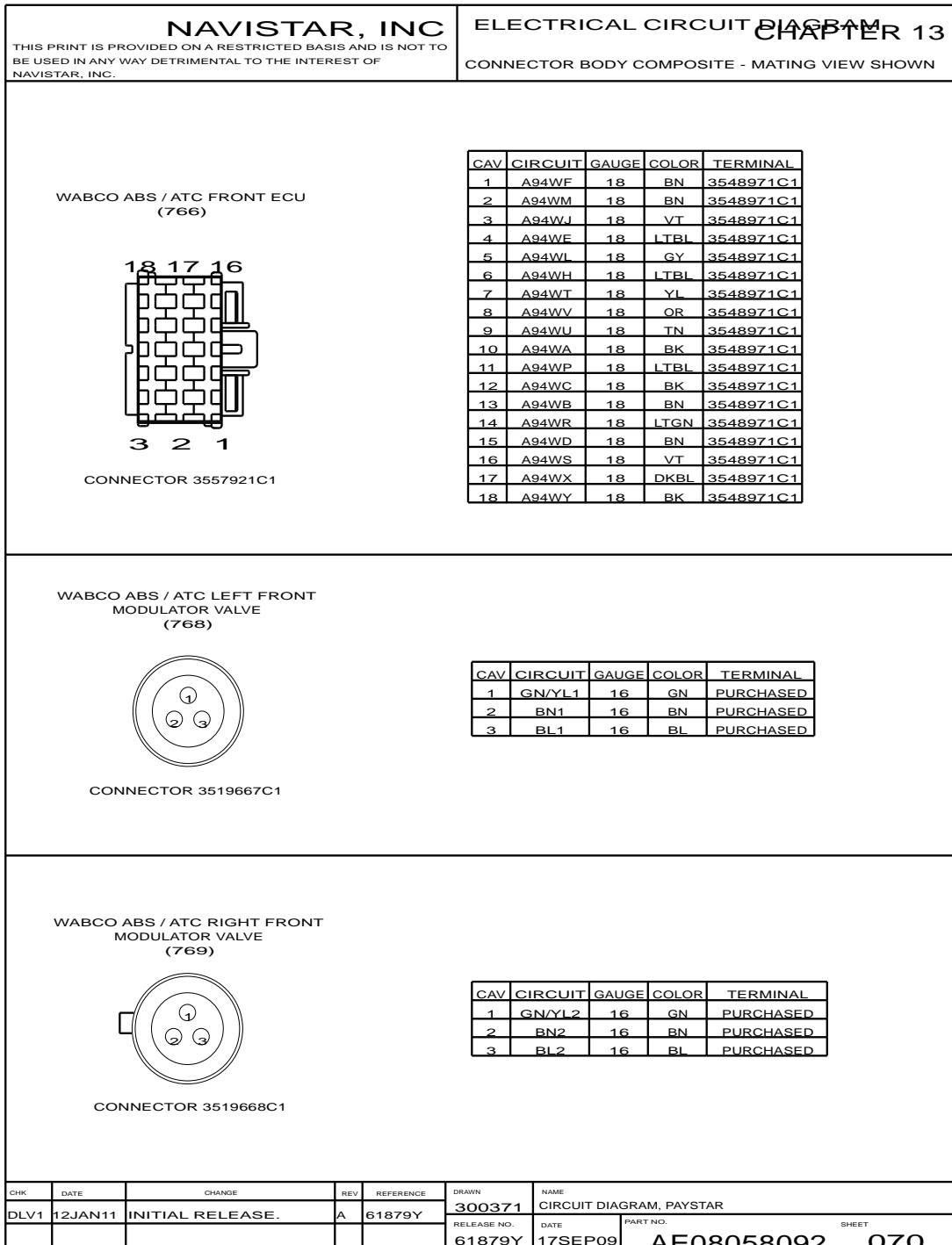


Figure 276 Connector Composites (766 / 768 / 769)

13.90. CONNECTOR COMPOSITES (770 / 771 / 774 / 775), P. 71

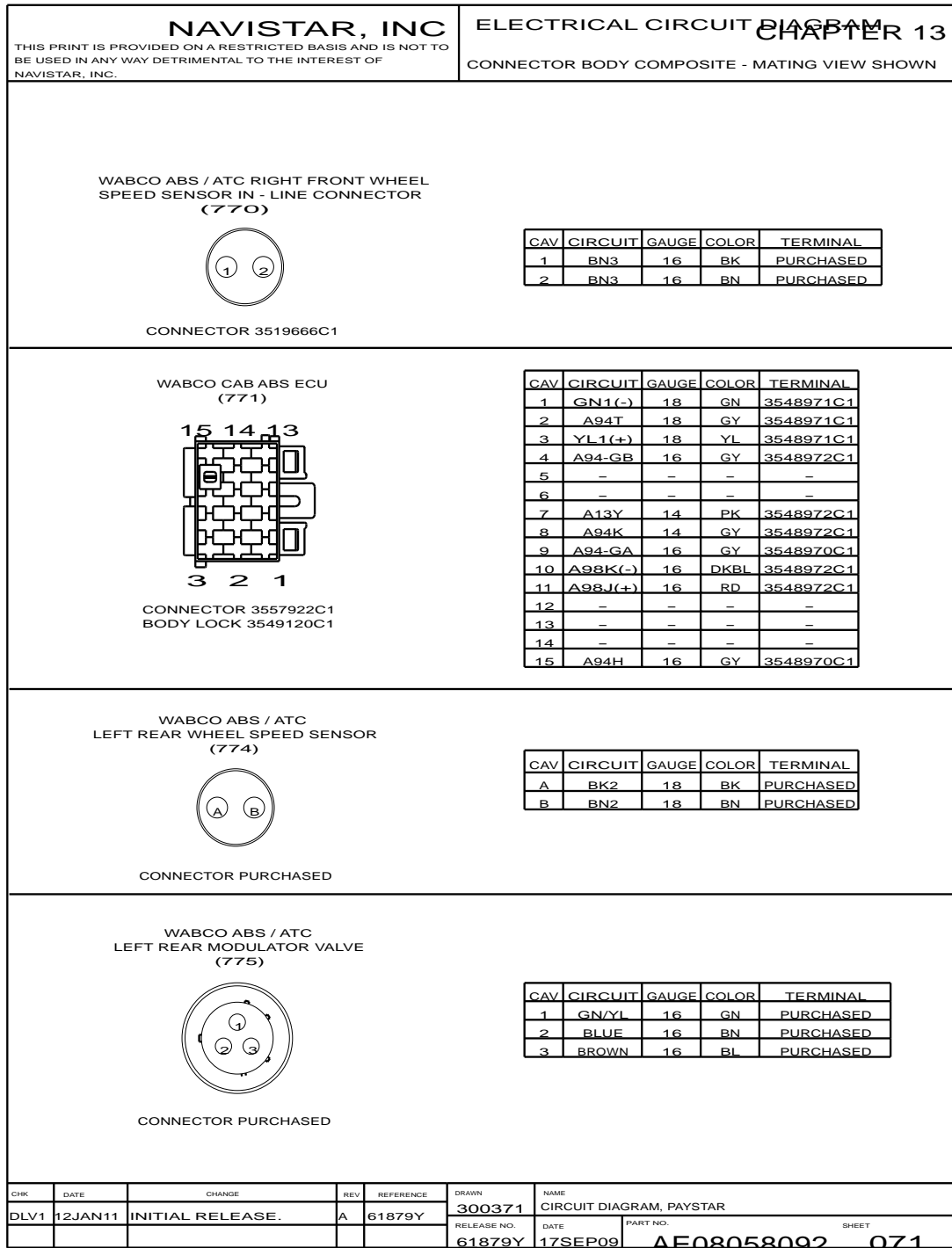


Figure 277 Connector Composites (770 / 771 / 774 / 775)

13.91. CONNECTOR COMPOSITES (776 / 777 / 778 / 800F), P. 72

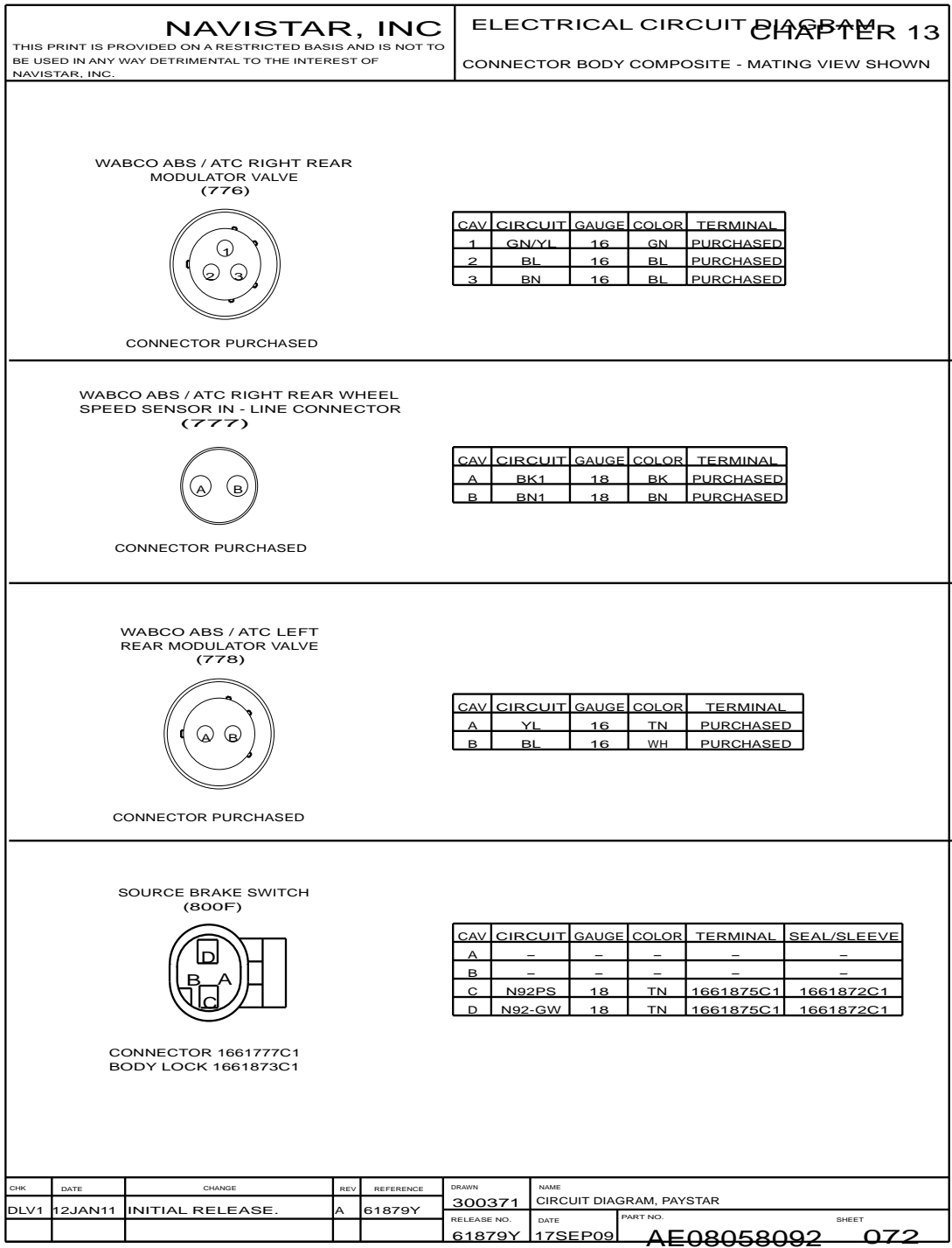


Figure 278 Connector Composites (776 / 777 / 778 / 800F)



13.92. CONNECTOR COMPOSITES (800M / 808M / 809F), P. 73

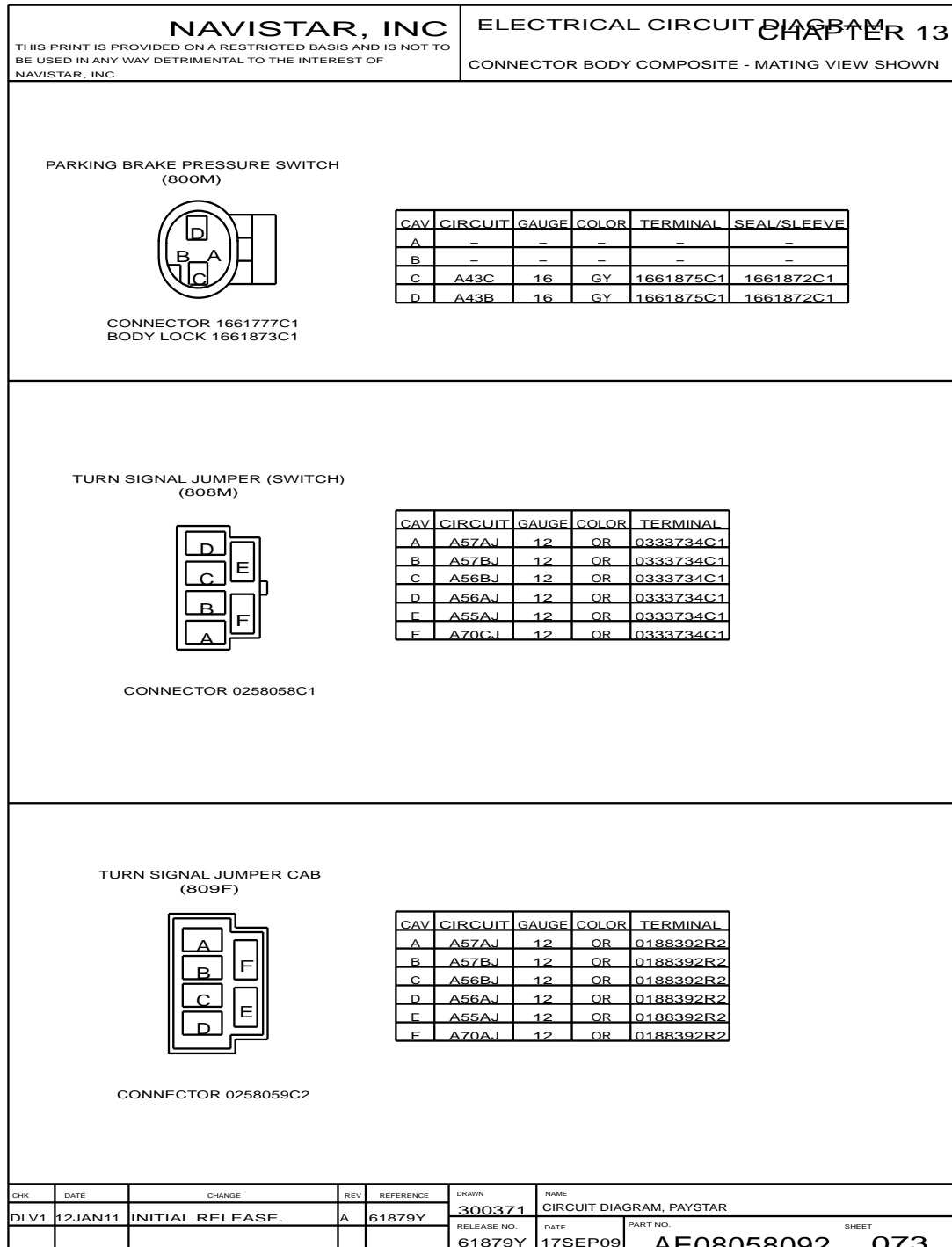


Figure 279 Connector Composites (800M / 808M / 809F)

13.93. CONNECTOR COMPOSITES (823M / 851 / \*851M / 854), P. 74

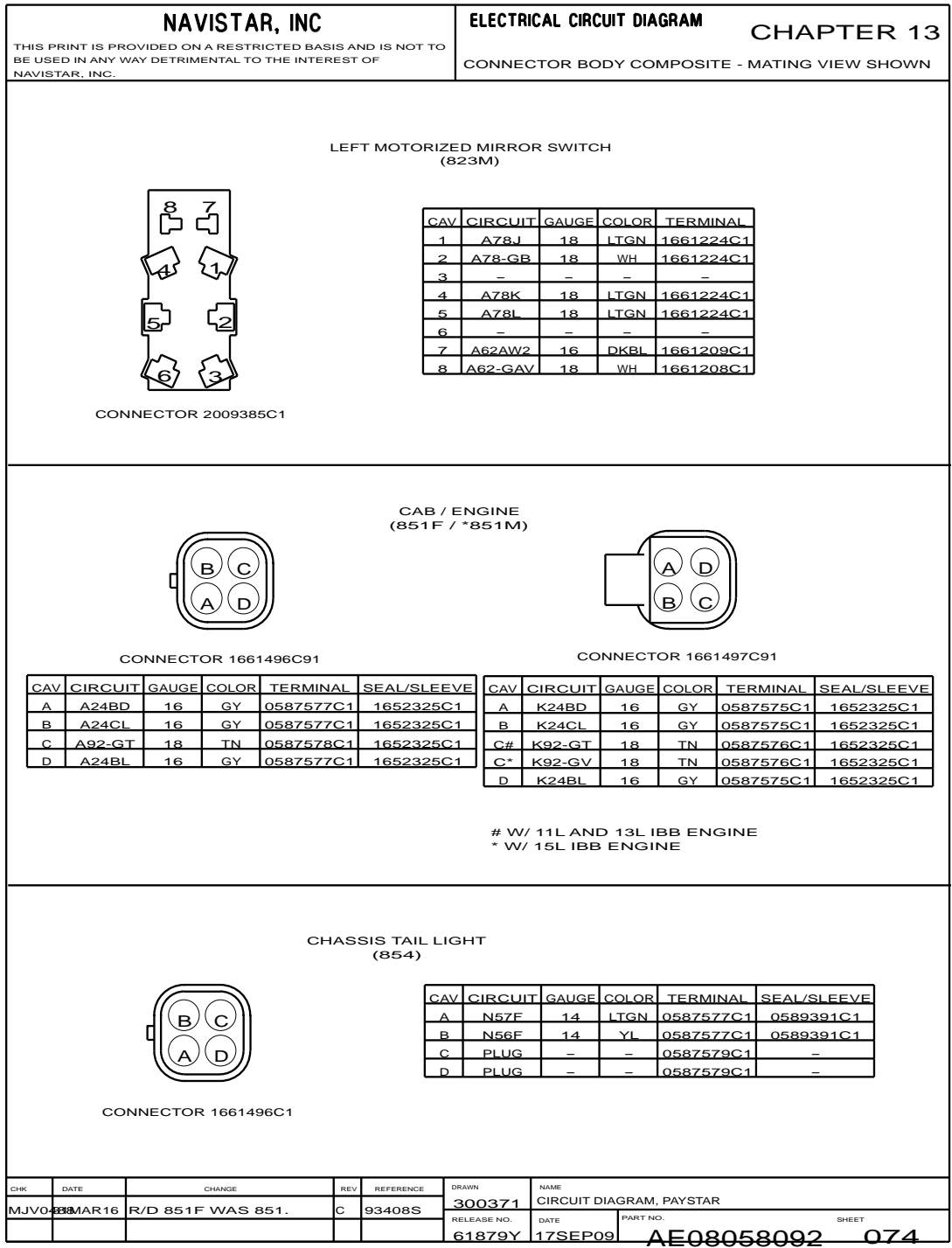


Figure 280 Connector Composites (823M / 851 / \*851M / 854)

13.94. CONNECTOR COMPOSITES (873 / 875M / 876M / 878F), P. 75

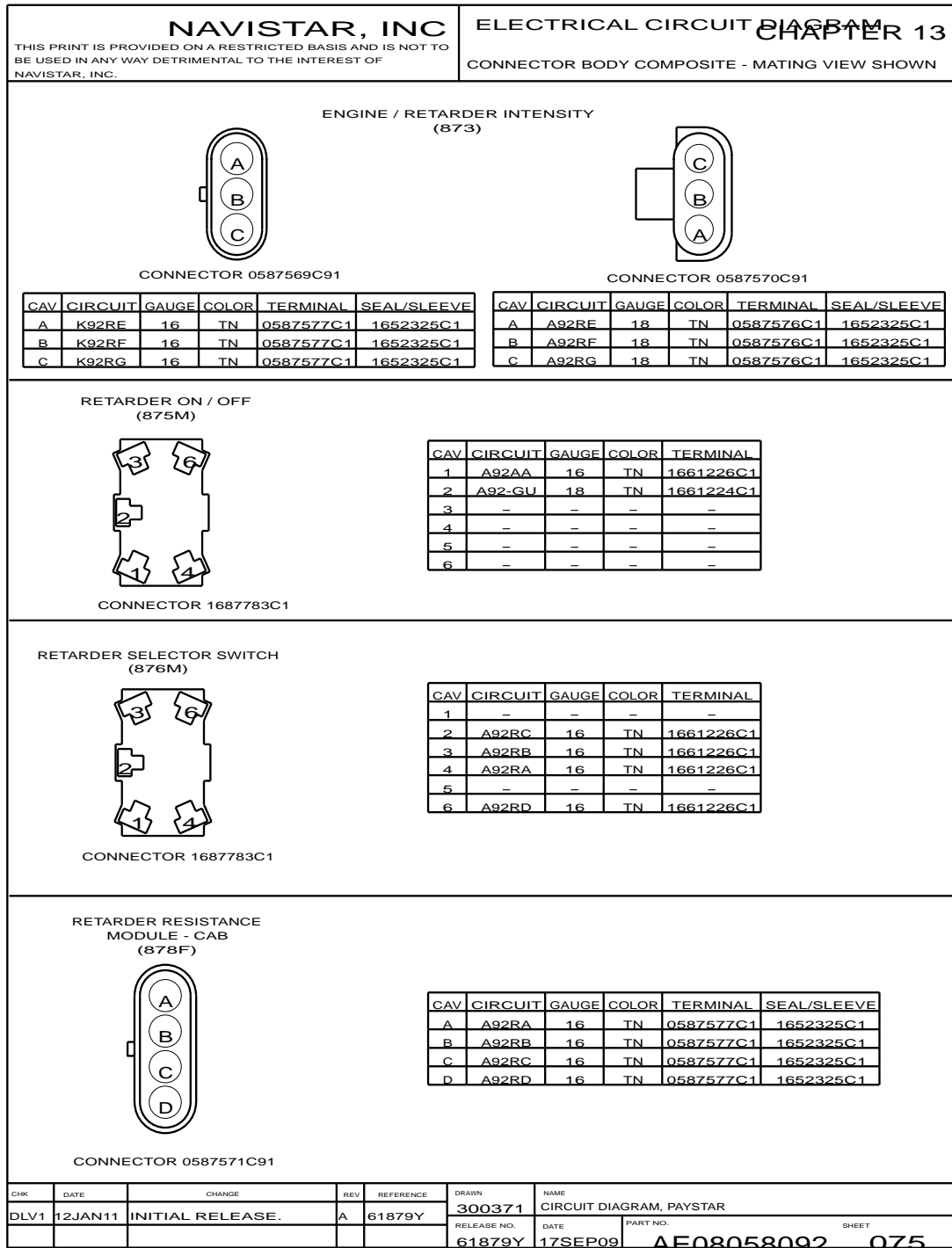


Figure 281 Connector Composites (873 / 875M / 876M / 878F)

13.95. CONNECTOR COMPOSITES (879M / 881F / 884F / 887), P. 76

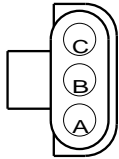

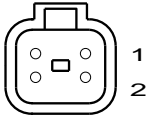
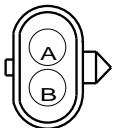
<b>NAVISTAR, INC</b> <small>THIS PRINT IS PROVIDED ON A RESTRICTED BASIS AND IS NOT TO BE USED IN ANY WAY DETRIMENTAL TO THE INTEREST OF NAVISTAR, INC.</small>				ELECTRICAL CIRCUIT DIAGRAM <b>CHAPTER 13</b> CONNECTOR BODY COMPOSITE - MATING VIEW SHOWN																										
<p>RETARDER RESISTANCE MODULE - ENGINE (879M)</p>  <table border="1" style="margin-left: auto; margin-right: auto; border-collapse: collapse;"> <thead> <tr> <th>CAV</th> <th>CIRCUIT</th> <th>GAUGE</th> <th>COLOR</th> <th>TERMINAL</th> <th>SEAL/SLEEVE</th> </tr> </thead> <tbody> <tr> <td>A</td> <td>A92RE</td> <td>18</td> <td>TN</td> <td>0587578C1</td> <td>1652325C1</td> </tr> <tr> <td>B</td> <td>A92RF</td> <td>18</td> <td>TN</td> <td>0587578C1</td> <td>1652325C1</td> </tr> <tr> <td>C</td> <td>A92RG</td> <td>18</td> <td>TN</td> <td>0587578C1</td> <td>1652325C1</td> </tr> </tbody> </table> <p>CONNECTOR 3519221C91</p>						CAV	CIRCUIT	GAUGE	COLOR	TERMINAL	SEAL/SLEEVE	A	A92RE	18	TN	0587578C1	1652325C1	B	A92RF	18	TN	0587578C1	1652325C1	C	A92RG	18	TN	0587578C1	1652325C1	
CAV	CIRCUIT	GAUGE	COLOR	TERMINAL	SEAL/SLEEVE																									
A	A92RE	18	TN	0587578C1	1652325C1																									
B	A92RF	18	TN	0587578C1	1652325C1																									
C	A92RG	18	TN	0587578C1	1652325C1																									
<p>XMSN OVERHEAT LIGHT (881F)</p>  <table border="1" style="margin-left: auto; margin-right: auto; border-collapse: collapse;"> <thead> <tr> <th>CAV</th> <th>CIRCUIT</th> <th>GAUGE</th> <th>COLOR</th> <th>TERMINAL</th> </tr> </thead> <tbody> <tr> <td>A&amp;</td> <td>A13BP</td> <td>18</td> <td>PK</td> <td>0870923R1</td> </tr> <tr> <td>A&amp;</td> <td>A13BM</td> <td>18</td> <td>PK</td> <td>0870923R1</td> </tr> <tr> <td>B</td> <td>A92ML</td> <td>18</td> <td>TN</td> <td>0241117R1</td> </tr> </tbody> </table> <p>CONNECTOR 0481140C1      &amp; MUTUAL EXCLUSIVE</p>						CAV	CIRCUIT	GAUGE	COLOR	TERMINAL	A&	A13BP	18	PK	0870923R1	A&	A13BM	18	PK	0870923R1	B	A92ML	18	TN	0241117R1					
CAV	CIRCUIT	GAUGE	COLOR	TERMINAL																										
A&	A13BP	18	PK	0870923R1																										
A&	A13BM	18	PK	0870923R1																										
B	A92ML	18	TN	0241117R1																										
<p>MODULE CONNECTOR (884F)</p>  <table border="1" style="margin-left: auto; margin-right: auto; border-collapse: collapse;"> <thead> <tr> <th>CAV</th> <th>CIRCUIT</th> <th>GAUGE</th> <th>COLOR</th> <th>TERMINAL</th> </tr> </thead> <tbody> <tr> <td>1</td> <td>A77AH</td> <td>16</td> <td>LTGN</td> <td>1680206C1</td> </tr> <tr> <td>2</td> <td>A77AJ</td> <td>16</td> <td>LTGN</td> <td>1680206C1</td> </tr> <tr> <td>3</td> <td>A77AK</td> <td>16</td> <td>LTGN</td> <td>1680206C1</td> </tr> <tr> <td>4</td> <td>A77AL</td> <td>16</td> <td>LTGN</td> <td>1680206C1</td> </tr> </tbody> </table> <p>CONNECTOR 3503598C1</p>						CAV	CIRCUIT	GAUGE	COLOR	TERMINAL	1	A77AH	16	LTGN	1680206C1	2	A77AJ	16	LTGN	1680206C1	3	A77AK	16	LTGN	1680206C1	4	A77AL	16	LTGN	1680206C1
CAV	CIRCUIT	GAUGE	COLOR	TERMINAL																										
1	A77AH	16	LTGN	1680206C1																										
2	A77AJ	16	LTGN	1680206C1																										
3	A77AK	16	LTGN	1680206C1																										
4	A77AL	16	LTGN	1680206C1																										
<p>APADS (887)</p>  <table border="1" style="margin-left: auto; margin-right: auto; border-collapse: collapse;"> <thead> <tr> <th>CAV</th> <th>CIRCUIT</th> <th>GAUGE</th> <th>COLOR</th> <th>TERMINAL</th> <th>SEAL/SLEEVE</th> </tr> </thead> <tbody> <tr> <td>A*</td> <td>K23AC</td> <td>18</td> <td>TN</td> <td>0587578C1</td> <td>1652325C1</td> </tr> <tr> <td>A#</td> <td>K23AC</td> <td>18</td> <td>TN</td> <td>0587578C1</td> <td>3517771C1</td> </tr> <tr> <td>B</td> <td>K77AE</td> <td>14</td> <td>LTGN</td> <td>0587577C1</td> <td>0589391C1</td> </tr> </tbody> </table> <p>CONNECTOR 0587567C91</p> <p style="text-align: right;">* W/ FAN OVERRIDE # N/ FAN OVERRIDE</p>						CAV	CIRCUIT	GAUGE	COLOR	TERMINAL	SEAL/SLEEVE	A*	K23AC	18	TN	0587578C1	1652325C1	A#	K23AC	18	TN	0587578C1	3517771C1	B	K77AE	14	LTGN	0587577C1	0589391C1	
CAV	CIRCUIT	GAUGE	COLOR	TERMINAL	SEAL/SLEEVE																									
A*	K23AC	18	TN	0587578C1	1652325C1																									
A#	K23AC	18	TN	0587578C1	3517771C1																									
B	K77AE	14	LTGN	0587577C1	0589391C1																									
CHK	DATE	CHANGE	REV	REFERENCE	DRAWN	NAME																								
012	17APR13	ADDED:CIRC K23C IN	B	91786V	300371	CIRCUIT DIAGRAM, PAYSTAR																								
	R/D 887	& ADDED R/D 884F.			RELEASE NO. 61879Y	DATE 17SEP09																								
						PART NO. AE08058092																								
						SHEET 076																								

Figure 282 Connector Composites (879M / 881F / 884F / 887)

13.96. CONNECTOR COMPOSITES (887M / 907M / 931F), P. 76A

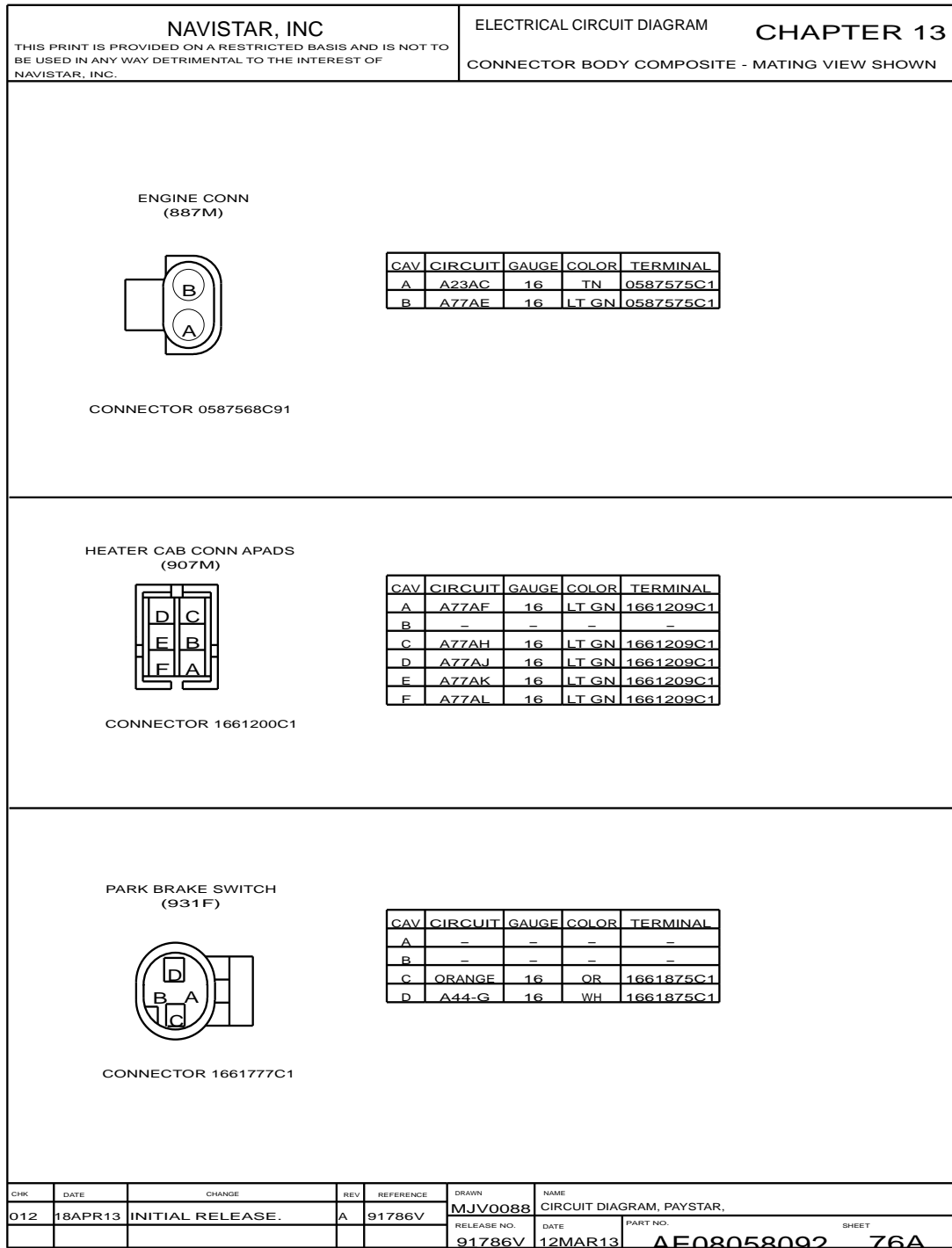


Figure 283 Connector Composites (887M / 907M / 931F)

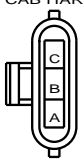
13.97. CONNECTOR COMPOSITES (922M / 923F / 925), P. 77

<b>NAVISTAR, INC</b>				<b>ELECTRICAL CIRCUIT DIAGRAM</b>				<b>CHAPTER 13</b>			
THIS PRINT IS PROVIDED ON A RESTRICTED BASIS AND IS NOT TO BE USED IN ANY WAY DETRIMENTAL TO THE INTEREST OF NAVISTAR, INC.				CONNECTOR BODY COMPOSITE - MATING VIEW SHOWN							

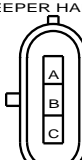
**TRAILER SOCKET #1 (922M)**  
(LOCATED BEHIND DRIVER'S SEAT AT B - PILLAR)

CAB HARNESS



CONNECTOR 1667733C1  
BODY LOCK 1667734C1

SLEEPER HARNESS



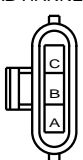
CONNECTOR 1667732C1  
BODY LOCK 1667734C1

CAV	CIRCUIT	GAUGE	COLOR	TERMINAL	SEAL/SLEEVE	CAV	CIRCUIT	GAUGE	COLOR	TERMINAL	SEAL/SLEEVE
A	A70C	10	OR	1667737C1	1667735C1	A	H70C	10	OR	2025425C1	1667739C1
B	A68B	10	BN	1667737C1	1667735C1	B	H68B	10	BN	2025425C1	1667739C1
C	A94AF	10	GY	1667737C1	1667735C1	C	H94AF	10	GY	2025425C1	1667739C1

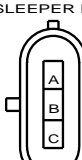
**TRAILER SOCKET #2 (923F)**  
(LOCATED BEHIND DRIVER'S SEAT AT B - PILLAR)

CAB HARNESS



CONNECTOR 1667732C1  
BODY LOCK 1667734C1

SLEEPER HARNESS



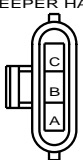
CONNECTOR 1667733C1  
BODY LOCK 1667734C1

CAV	CIRCUIT	GAUGE	COLOR	TERMINAL	SEAL/SLEEVE	CAV	CIRCUIT	GAUGE	COLOR	TERMINAL	SEAL/SLEEVE
A	A58S	12	BN	2025424C1	1671603C1	A	H58S	12	BN	1667737C1	1617603C1
B	A56C	12	OR	2025424C1	1671603C1	B	H56C	12	OR	1667737C1	1617603C1
C	A57C	12	OR	2025424C1	1671603C1	C	H57C	12	OR	1667737C1	1617603C1

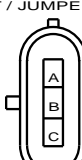
**TRAILER SOCKET #1 (925)**  
(LOCATED IN LEFT LUGGAGE COMPARTMENT)

SLEEPER HARNESS



CONNECTOR 1667733C1  
BODY LOCK 1667734C1

SOCKET / JUMPER HARNESS



CONNECTOR 1667732C1  
BODY LOCK 1667734C1

CAV	CIRCUIT	GAUGE	COLOR	TERMINAL	SEAL/SLEEVE	CAV	CIRCUIT	GAUGE	COLOR	TERMINAL	SEAL/SLEEVE
A	H70C	10	RD	1667737C1	1667739C1	A	A70C	10	OR	2025425C1	1667739C1
B	H68B	12	BK	1667737C1	1667739C1	B	A68B	10	BN	2025425C1	1667739C1
C	H94AF	10	BL	1667737C1	1667739C1	C	A94AF	10	GY	2025425C1	1667739C1

CHK	DATE	CHANGE	REV	REFERENCE	DRAWN	NAME
					300371	CIRCUIT DIAGRAM, PAYSTAR
MJVO	13MAR16	REVISED AND REDRAWN.	B	93408S	RELEASE NO.	DATE
					61879Y	17SEP09
					PART NO.	SHEET
					AE08058092	077

Figure 284 Connector Composites (922M / 923F / 925)

13.98. CONNECTOR COMPOSITES (926 / 934M / 935), P. 78

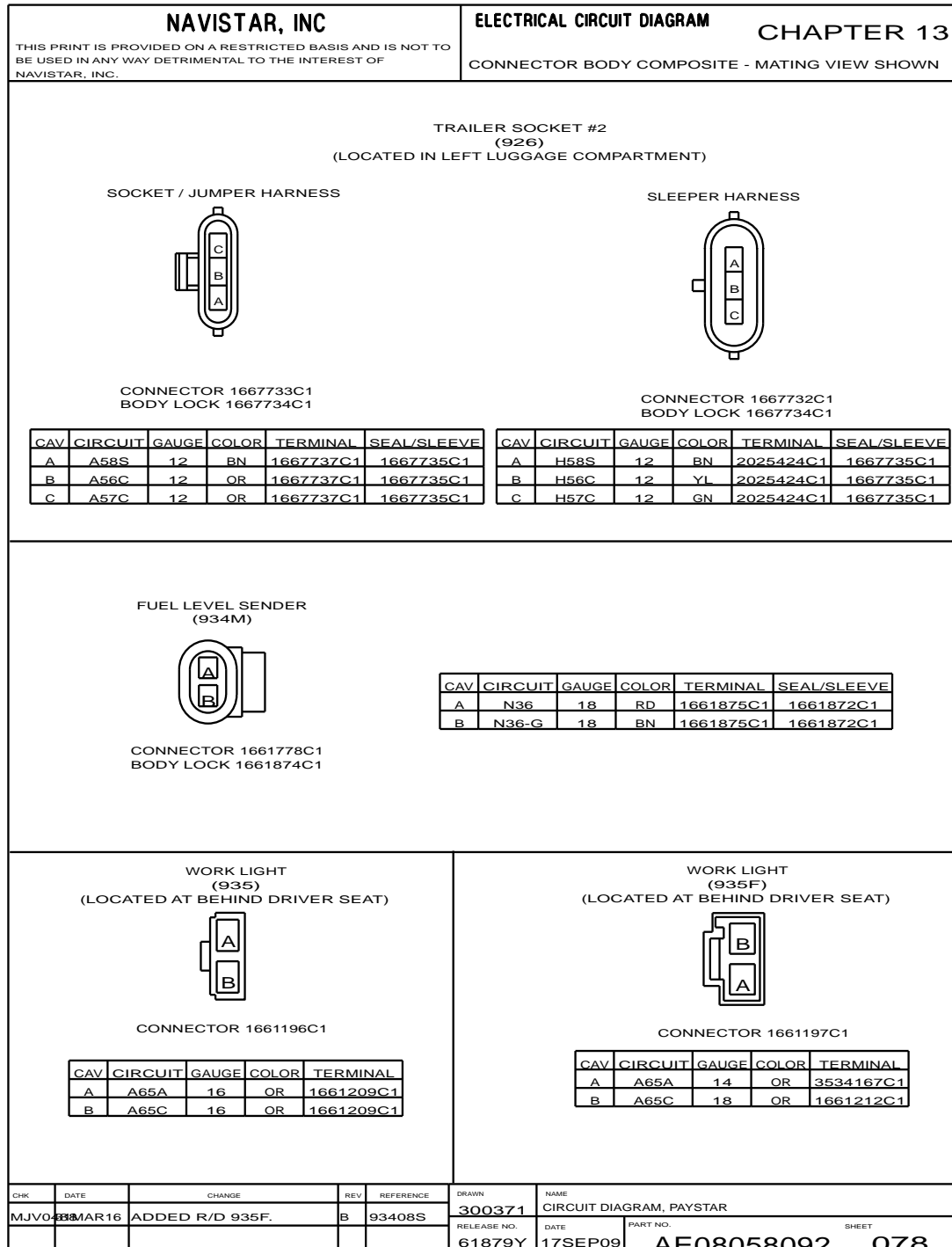


Figure 285 Connector Composites (926 / 934M / 935)

13.99. CONNECTOR COMPOSITES (946 / 950 / 950F), P. 79

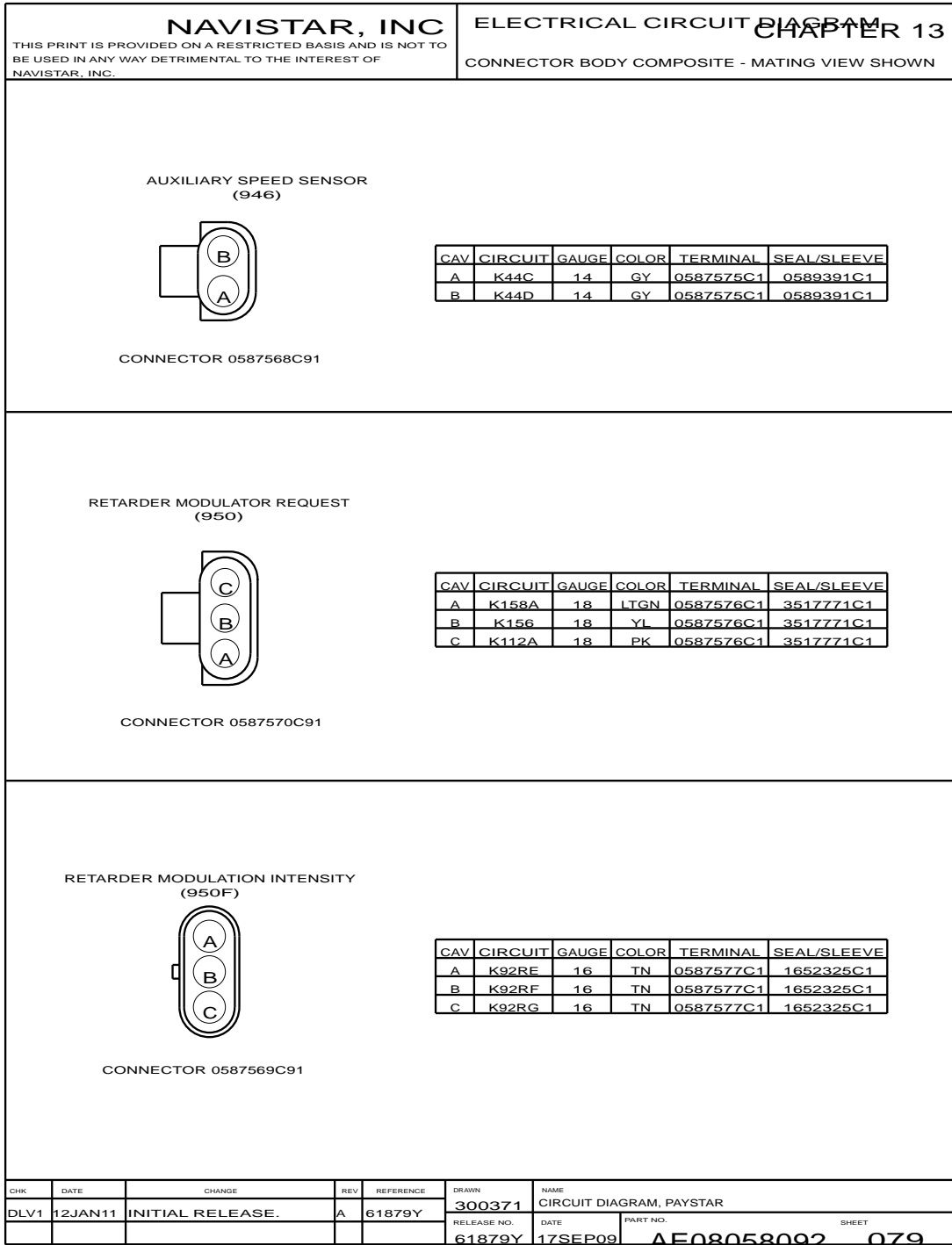


Figure 286 Connector Composites (946 / 950 / 950F)



13.100. CONNECTOR COMPOSITES (958 / 958F / 961), P. 80

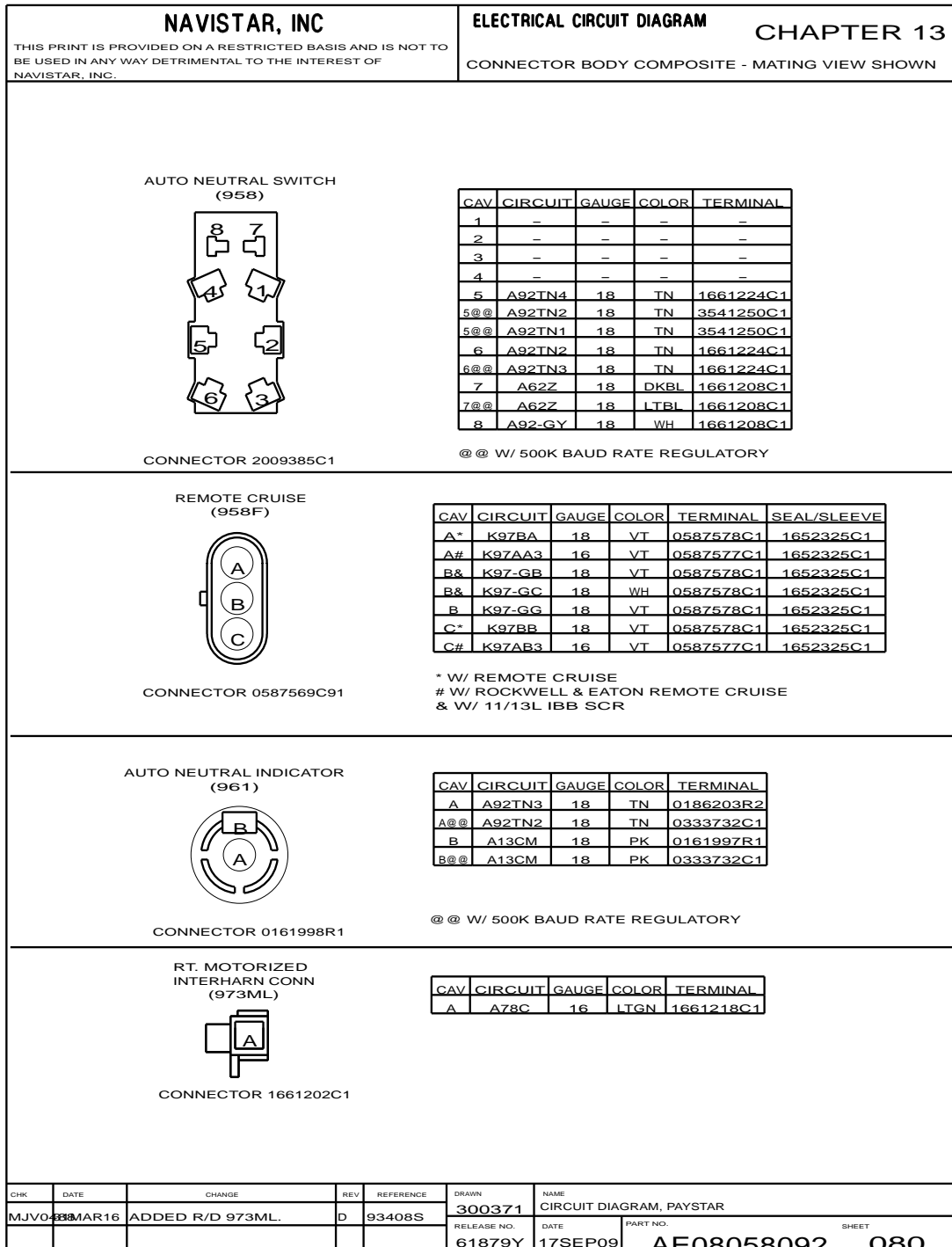


Figure 287 Connector Composites (958 / 958F / 961)

13.101. CONNECTOR COMPOSITES (1000 / 1027), P. 81

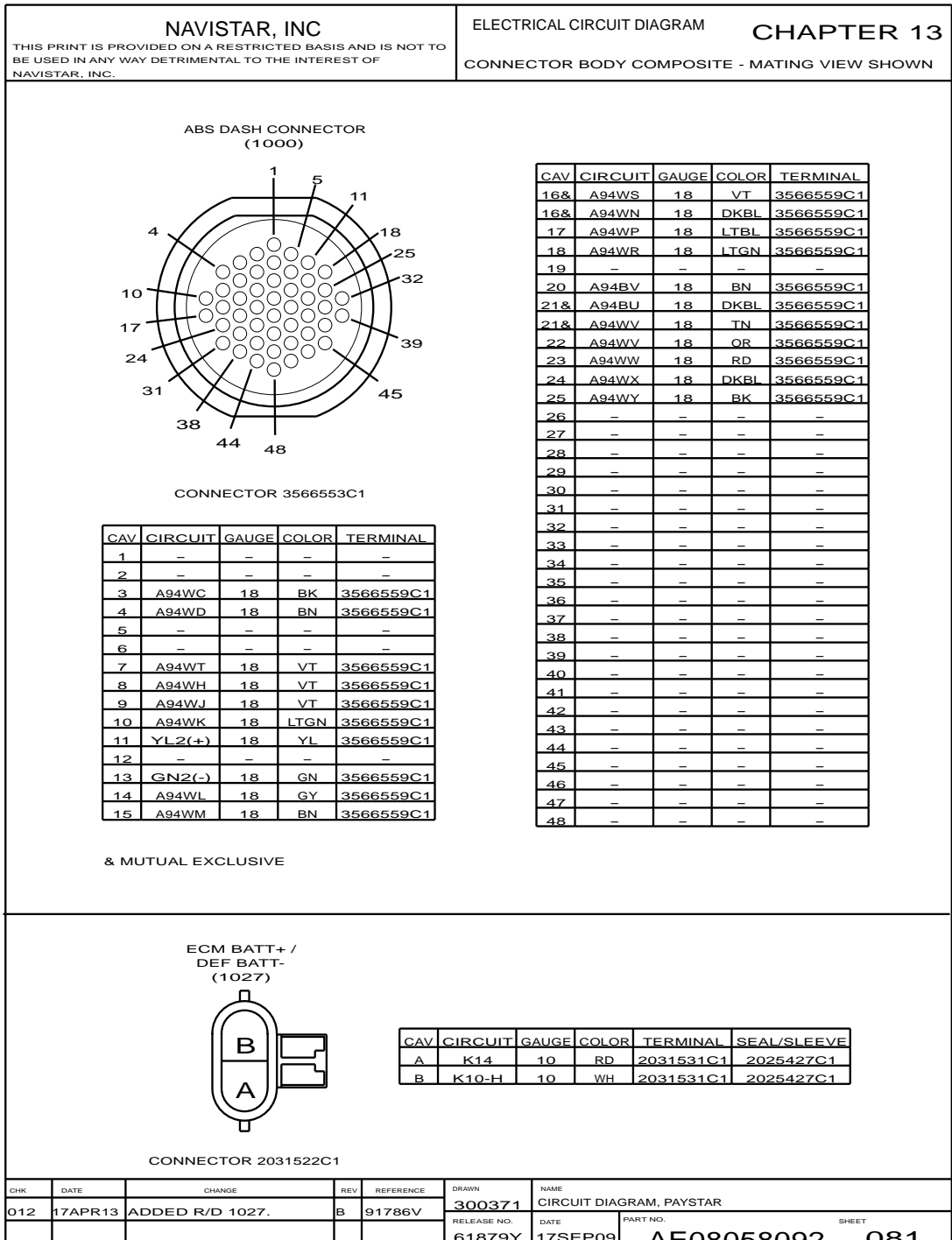


Figure 288 Connector Composites (1000 / 1027)

13.102. CONNECTOR COMPOSITES (1033F / 1034F / 1039 / 1040), P. 82

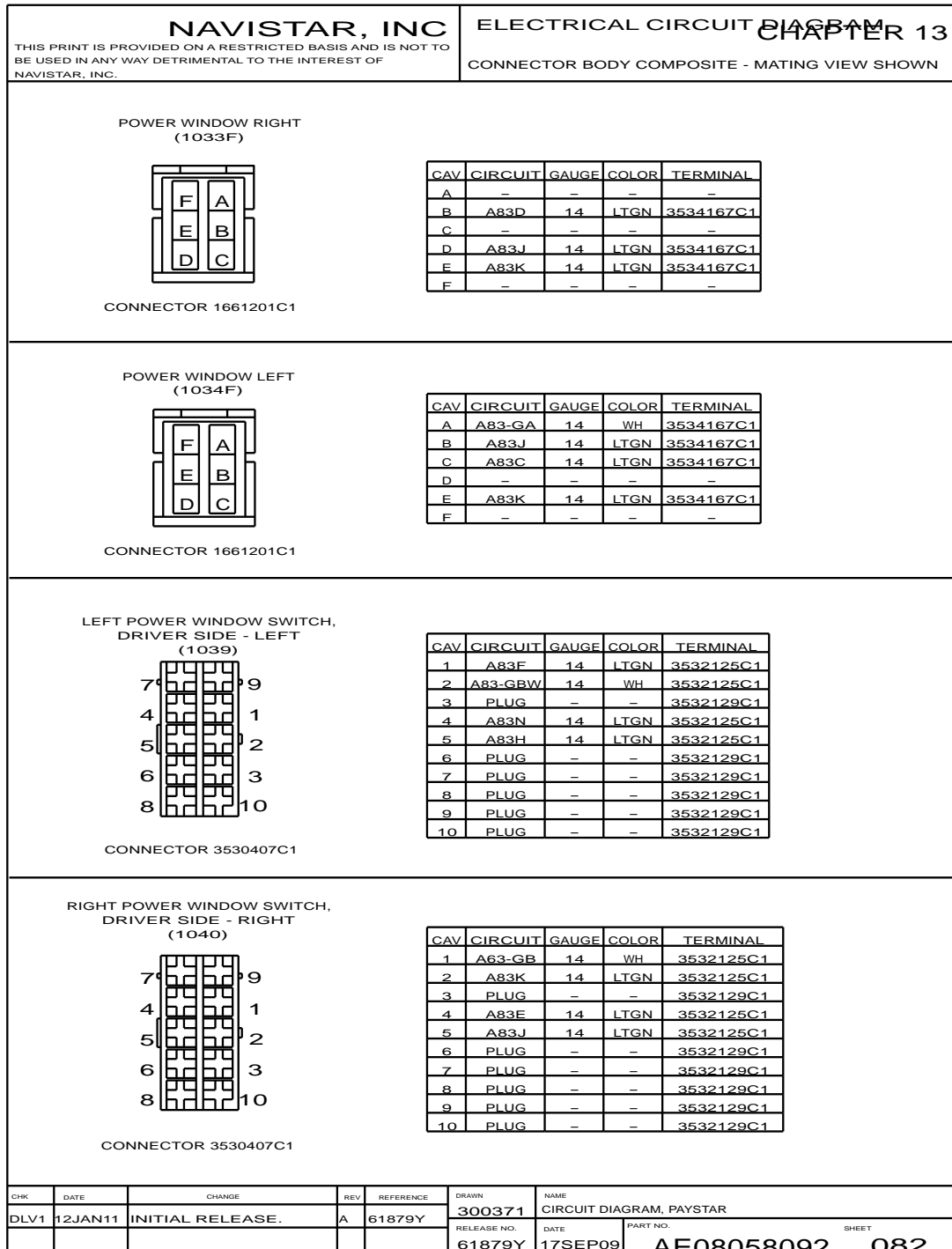


Figure 289 Connector Composites (1033F / 1034F / 1039 / 1040)

13.103. CONNECTOR COMPOSITES (1041 / 1042 / 1043 / 1044), P. 83

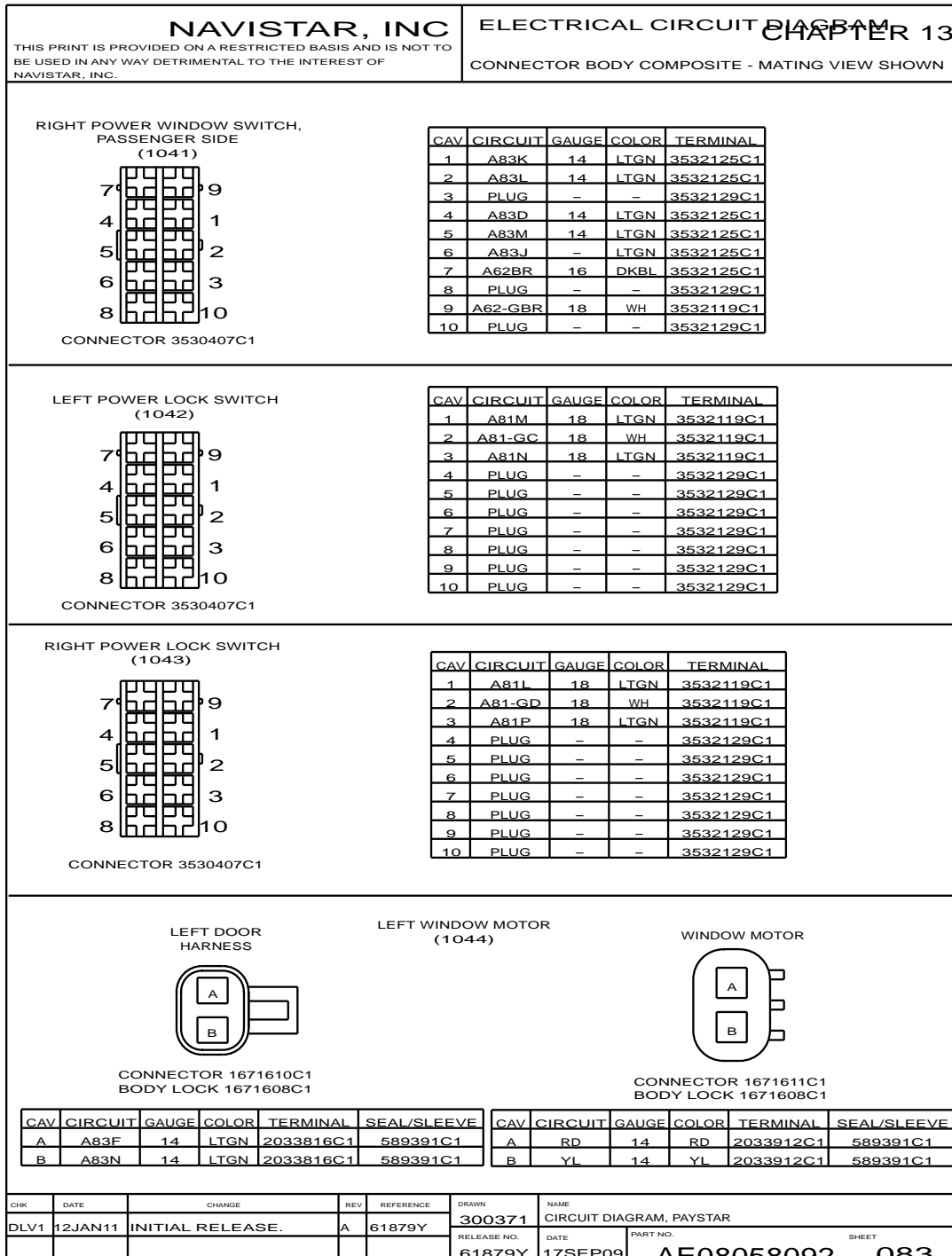


Figure 290 Connector Composites (1041 / 1042 / 1043 / 1044)

13.104. CONNECTOR COMPOSITES (1045 / 1046 / 1047 / 1048F), P. 84

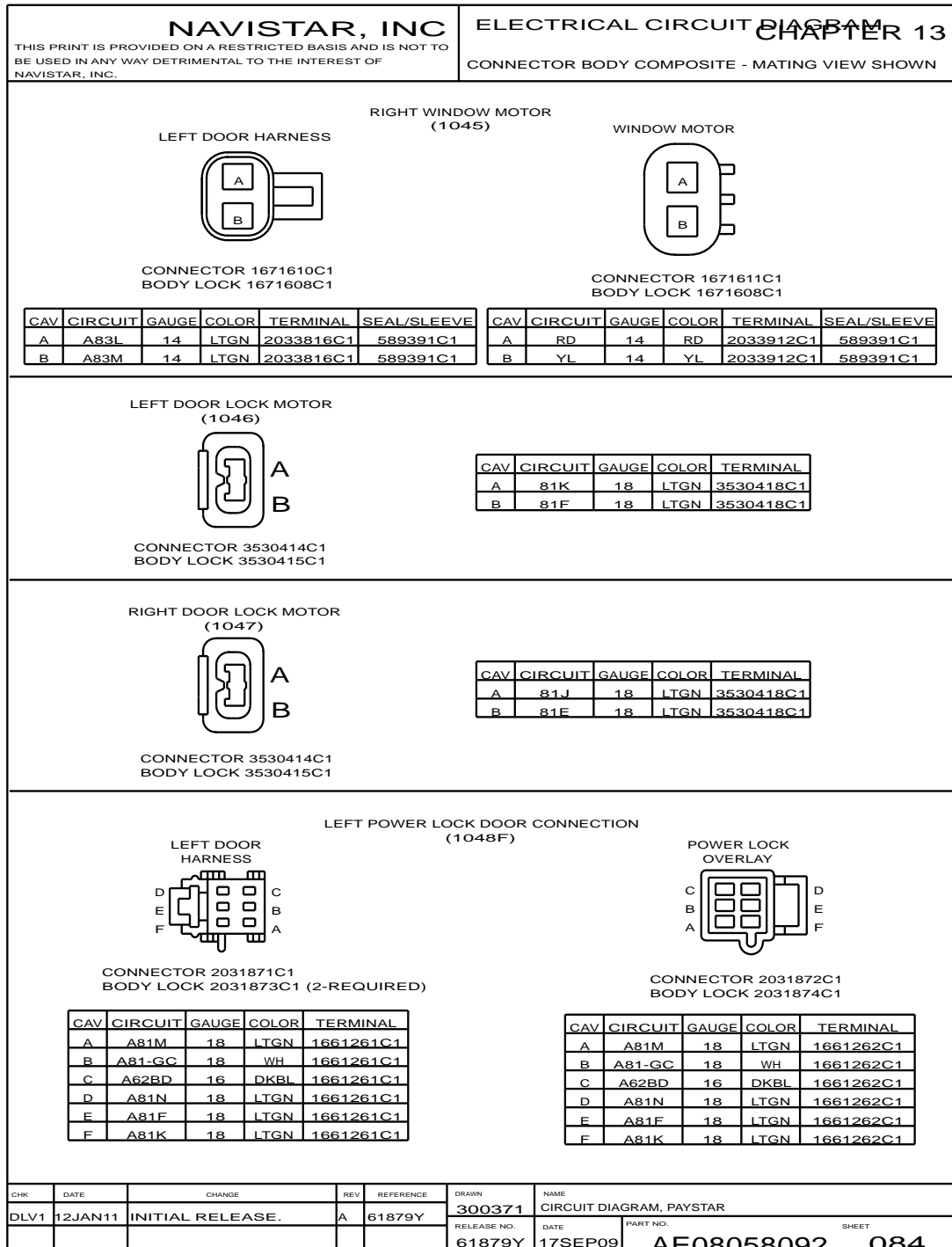


Figure 291 Connector Composites (1045 / 1046 / 1047 / 1048F)

13.105. CONNECTOR COMPOSITES (1049F / 1050M / 1051 / 1052 / 1054M), P. 85


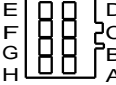


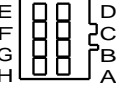
<b>NAVISTAR, INC</b> <small>THIS PRINT IS PROVIDED ON A RESTRICTED BASIS AND IS NOT TO BE USED IN ANY WAY DETRIMENTAL TO THE INTEREST OF NAVISTAR, INC.</small>				<b>ELECTRICAL CIRCUIT DIAGRAM</b> <b>CHAPTER 13</b> CONNECTOR BODY COMPOSITE - MATING VIEW SHOWN																																																															
RIGHT POWER LOCK DOOR CONNECTION (1049F)  CONNECTOR 2031872C1 BODY LOCK 2031874C1				<table border="1" style="width:100%; border-collapse: collapse;"> <thead> <tr> <th>CAV</th> <th>CIRCUIT</th> <th>GAUGE</th> <th>COLOR</th> <th>TERMINAL</th> </tr> </thead> <tbody> <tr><td>A</td><td>A81P</td><td>18</td><td>LTGN</td><td>1661262C1</td></tr> <tr><td>B</td><td>A81J</td><td>18</td><td>LTGN</td><td>1661262C1</td></tr> <tr><td>C</td><td>A81L</td><td>18</td><td>LTGN</td><td>1661262C1</td></tr> <tr><td>D</td><td>A81E</td><td>18</td><td>LTGN</td><td>1661262C1</td></tr> <tr><td>E</td><td>A81-GD</td><td>18</td><td>WH</td><td>1661262C1</td></tr> <tr><td>F</td><td>-</td><td>-</td><td>-</td><td>-</td></tr> </tbody> </table>				CAV	CIRCUIT	GAUGE	COLOR	TERMINAL	A	A81P	18	LTGN	1661262C1	B	A81J	18	LTGN	1661262C1	C	A81L	18	LTGN	1661262C1	D	A81E	18	LTGN	1661262C1	E	A81-GD	18	WH	1661262C1	F	-	-	-	-																									
CAV	CIRCUIT	GAUGE	COLOR	TERMINAL																																																															
A	A81P	18	LTGN	1661262C1																																																															
B	A81J	18	LTGN	1661262C1																																																															
C	A81L	18	LTGN	1661262C1																																																															
D	A81E	18	LTGN	1661262C1																																																															
E	A81-GD	18	WH	1661262C1																																																															
F	-	-	-	-																																																															
LEFT POWER MIRROR & COURTESY LIGHT (1050M)  CONNECTOR 3515762C1 BODY LOCK 3515764C1-2				<table border="1" style="width:100%; border-collapse: collapse;"> <thead> <tr> <th>CAV</th> <th>CIRCUIT</th> <th>GAUGE</th> <th>COLOR</th> <th>TERMINAL</th> </tr> </thead> <tbody> <tr><td>A</td><td>A63V</td><td>18</td><td>DKBL</td><td>1661261C1</td></tr> <tr><td>B</td><td>A63H</td><td>18</td><td>DKBL</td><td>1661261C1</td></tr> <tr><td>C</td><td>A11-GZ</td><td>18</td><td>WH</td><td>1661261C1</td></tr> <tr><td>D#</td><td>A78R</td><td>18</td><td>LTGN</td><td>1661261C1</td></tr> <tr><td>D*</td><td>A58J</td><td>18</td><td>BN</td><td>1661261C1</td></tr> <tr><td>E#</td><td>A78N</td><td>18</td><td>LTGN</td><td>1661261C1</td></tr> <tr><td>E*</td><td>A78J</td><td>18</td><td>LTGN</td><td>1661261C1</td></tr> <tr><td>F#</td><td>A78P</td><td>18</td><td>LTGN</td><td>1661261C1</td></tr> <tr><td>F*</td><td>A78K</td><td>18</td><td>LTGN</td><td>1661261C1</td></tr> <tr><td>G</td><td>A78B</td><td>18</td><td>LTGN</td><td>1661261C1</td></tr> <tr><td>H</td><td>A63C</td><td>18</td><td>DKBL</td><td>1661261C1</td></tr> </tbody> </table> <p style="text-align: center;">* W/ SINGLE AXIS MIRROR # W/ DUAL AXIS MIRROR</p>				CAV	CIRCUIT	GAUGE	COLOR	TERMINAL	A	A63V	18	DKBL	1661261C1	B	A63H	18	DKBL	1661261C1	C	A11-GZ	18	WH	1661261C1	D#	A78R	18	LTGN	1661261C1	D*	A58J	18	BN	1661261C1	E#	A78N	18	LTGN	1661261C1	E*	A78J	18	LTGN	1661261C1	F#	A78P	18	LTGN	1661261C1	F*	A78K	18	LTGN	1661261C1	G	A78B	18	LTGN	1661261C1	H	A63C	18	DKBL	1661261C1
CAV	CIRCUIT	GAUGE	COLOR	TERMINAL																																																															
A	A63V	18	DKBL	1661261C1																																																															
B	A63H	18	DKBL	1661261C1																																																															
C	A11-GZ	18	WH	1661261C1																																																															
D#	A78R	18	LTGN	1661261C1																																																															
D*	A58J	18	BN	1661261C1																																																															
E#	A78N	18	LTGN	1661261C1																																																															
E*	A78J	18	LTGN	1661261C1																																																															
F#	A78P	18	LTGN	1661261C1																																																															
F*	A78K	18	LTGN	1661261C1																																																															
G	A78B	18	LTGN	1661261C1																																																															
H	A63C	18	DKBL	1661261C1																																																															
RIGHT DOOR SWITCH (1051)  CONNECTOR 3527798C1 RUBBER BOOT 3527799C1				<table border="1" style="width:100%; border-collapse: collapse;"> <thead> <tr> <th>CAV</th> <th>CIRCUIT</th> <th>GAUGE</th> <th>COLOR</th> <th>TERMINAL</th> </tr> </thead> <tbody> <tr><td>A</td><td>A63B</td><td>18</td><td>DKBL</td><td>3528062C1</td></tr> <tr><td>B</td><td>A63-GW</td><td>18</td><td>WH</td><td>3528062C1</td></tr> <tr><td>C</td><td>-</td><td>-</td><td>-</td><td>-</td></tr> </tbody> </table>				CAV	CIRCUIT	GAUGE	COLOR	TERMINAL	A	A63B	18	DKBL	3528062C1	B	A63-GW	18	WH	3528062C1	C	-	-	-	-																																								
CAV	CIRCUIT	GAUGE	COLOR	TERMINAL																																																															
A	A63B	18	DKBL	3528062C1																																																															
B	A63-GW	18	WH	3528062C1																																																															
C	-	-	-	-																																																															
LEFT DOOR SWITCH (1052)  CONNECTOR 3527798C1 RUBBER BOOT 3527799C1				<table border="1" style="width:100%; border-collapse: collapse;"> <thead> <tr> <th>CAV</th> <th>CIRCUIT</th> <th>GAUGE</th> <th>COLOR</th> <th>TERMINAL</th> </tr> </thead> <tbody> <tr><td>A</td><td>A63C</td><td>18</td><td>DKBL</td><td>3528062C1</td></tr> <tr><td>B</td><td>A63-GZ</td><td>18</td><td>WH</td><td>3528062C1</td></tr> <tr><td>C</td><td>-</td><td>-</td><td>-</td><td>-</td></tr> </tbody> </table>				CAV	CIRCUIT	GAUGE	COLOR	TERMINAL	A	A63C	18	DKBL	3528062C1	B	A63-GZ	18	WH	3528062C1	C	-	-	-	-																																								
CAV	CIRCUIT	GAUGE	COLOR	TERMINAL																																																															
A	A63C	18	DKBL	3528062C1																																																															
B	A63-GZ	18	WH	3528062C1																																																															
C	-	-	-	-																																																															
RIGHT POWER MIRROR & COURTESY LIGHT (1054M)  CONNECTOR 3515762C1 BODY LOCK 3515764C1-2				<table border="1" style="width:100%; border-collapse: collapse;"> <thead> <tr> <th>CAV</th> <th>CIRCUIT</th> <th>GAUGE</th> <th>COLOR</th> <th>TERMINAL</th> </tr> </thead> <tbody> <tr><td>A</td><td>A63X</td><td>18</td><td>DKBL</td><td>1661261C1</td></tr> <tr><td>B</td><td>A63Y</td><td>18</td><td>DKBL</td><td>1661261C1</td></tr> <tr><td>C</td><td>A11-GAE</td><td>18</td><td>WH</td><td>1661261C1</td></tr> <tr><td>D#</td><td>A78S</td><td>18</td><td>LTGN</td><td>1661261C1</td></tr> <tr><td>D*</td><td>A58L</td><td>18</td><td>BN</td><td>1661261C1</td></tr> <tr><td>E</td><td>A78E</td><td>18</td><td>LTGN</td><td>1661261C1</td></tr> <tr><td>F</td><td>A78F</td><td>18</td><td>LTGN</td><td>1661261C1</td></tr> <tr><td>G</td><td>A78A</td><td>18</td><td>LTGN</td><td>1661261C1</td></tr> <tr><td>H</td><td>A63B</td><td>18</td><td>DKBL</td><td>1661261C1</td></tr> </tbody> </table> <p style="text-align: center;">* W/ SINGLE AXIS MIRROR # W/ DUAL AXIS MIRROR</p>				CAV	CIRCUIT	GAUGE	COLOR	TERMINAL	A	A63X	18	DKBL	1661261C1	B	A63Y	18	DKBL	1661261C1	C	A11-GAE	18	WH	1661261C1	D#	A78S	18	LTGN	1661261C1	D*	A58L	18	BN	1661261C1	E	A78E	18	LTGN	1661261C1	F	A78F	18	LTGN	1661261C1	G	A78A	18	LTGN	1661261C1	H	A63B	18	DKBL	1661261C1										
CAV	CIRCUIT	GAUGE	COLOR	TERMINAL																																																															
A	A63X	18	DKBL	1661261C1																																																															
B	A63Y	18	DKBL	1661261C1																																																															
C	A11-GAE	18	WH	1661261C1																																																															
D#	A78S	18	LTGN	1661261C1																																																															
D*	A58L	18	BN	1661261C1																																																															
E	A78E	18	LTGN	1661261C1																																																															
F	A78F	18	LTGN	1661261C1																																																															
G	A78A	18	LTGN	1661261C1																																																															
H	A63B	18	DKBL	1661261C1																																																															
CHK	DATE	CHANGE	REV	REFERENCE	DRAWN	NAME																																																													
DLV1	12JAN11	INITIAL RELEASE.	A	61879Y	300371	CIRCUIT DIAGRAM, PAYSTAR																																																													
					RELEASE NO.	DATE	PART NO.																																																												
					61879Y	17SEP09	AE08058092																																																												
							SHEET 085																																																												

Figure 292 Connector Composites (1049F / 1050M / 1051 / 1052 / 1054M)

13.106. CONNECTOR COMPOSITES (1056M / 1057M / 1058M / 1059M / 1060M), P. 86

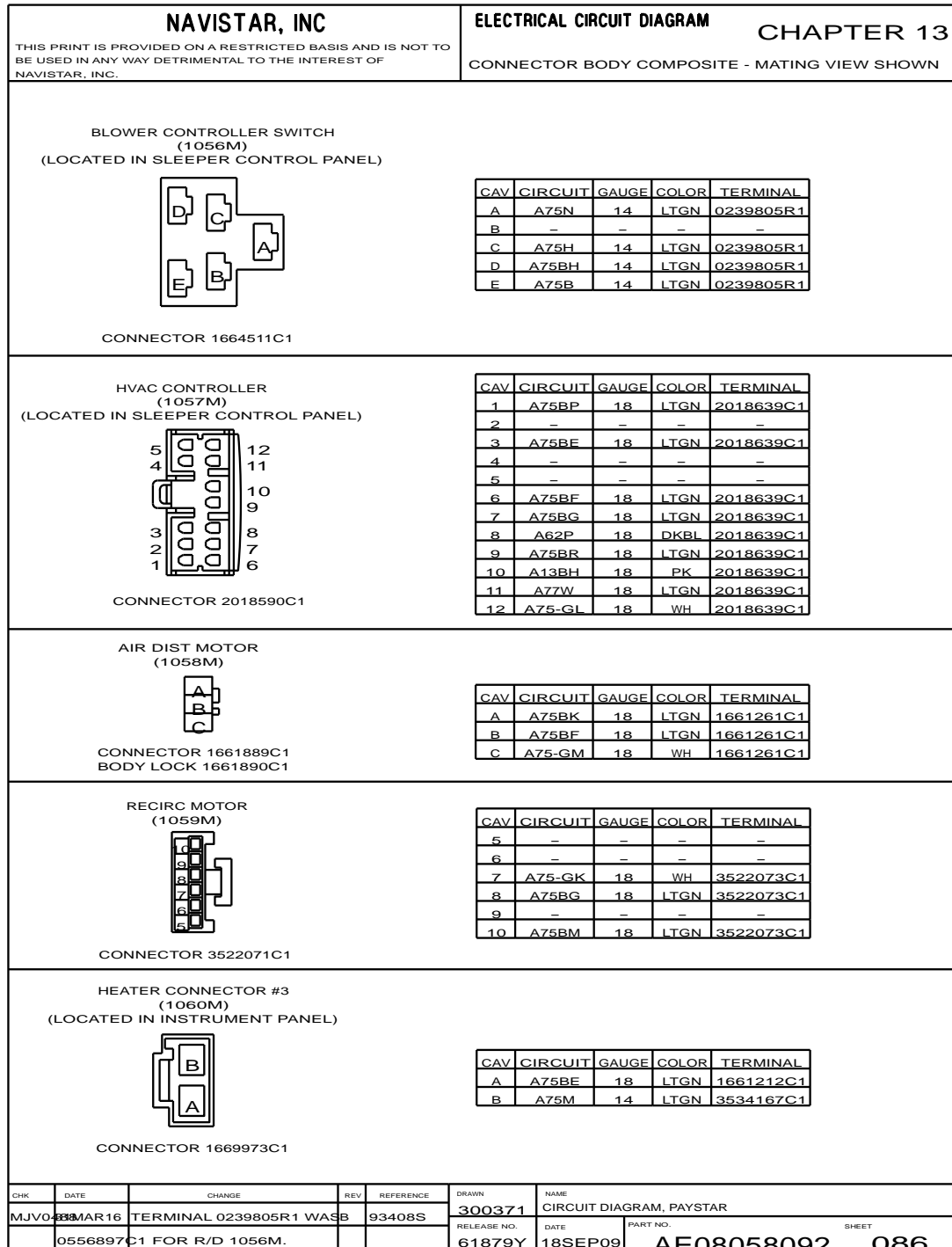


Figure 293 Connector Composites (1056M / 1057M / 1058M / 1059M / 1060M)

13.107. CONNECTOR COMPOSITES (1065M / 1085M / 1087M / 1090 / 1095F), P. 87

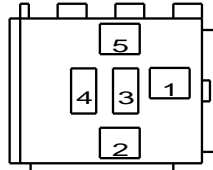
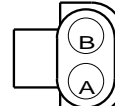

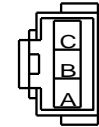

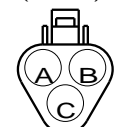
<b>NAVISTAR, INC</b>				<b>ELECTRICAL CIRCUIT DIAGRAM</b>				<b>CHAPTER 13</b>																																							
THIS PRINT IS PROVIDED ON A RESTRICTED BASIS AND IS NOT TO BE USED IN ANY WAY DETRIMENTAL TO THE INTEREST OF NAVISTAR, INC.				CONNECTOR BODY COMPOSITE - MATING VIEW SHOWN																																											
<p><b>ABS / XMSN INTERRUPT RELAY (1065M)</b></p> 																																															
<table border="1" style="width: 100%; border-collapse: collapse;"> <thead> <tr> <th>CAV</th> <th>CIRCUIT</th> <th>GAUGE</th> <th>COLOR</th> <th>TERMINAL</th> </tr> </thead> <tbody> <tr> <td>1</td> <td>A92GG</td> <td>18</td> <td>TN</td> <td>1661709C1</td> </tr> <tr> <td>2</td> <td>A94ST</td> <td>14</td> <td>GY</td> <td>1661709C1</td> </tr> <tr> <td>3</td> <td>-</td> <td>-</td> <td>-</td> <td>-</td> </tr> <tr> <td>4</td> <td>A94KP</td> <td>18</td> <td>TN</td> <td>1661709C1</td> </tr> <tr> <td>5</td> <td>A94VT</td> <td>16</td> <td>GY</td> <td>1661709C1</td> </tr> </tbody> </table>												CAV	CIRCUIT	GAUGE	COLOR	TERMINAL	1	A92GG	18	TN	1661709C1	2	A94ST	14	GY	1661709C1	3	-	-	-	-	4	A94KP	18	TN	1661709C1	5	A94VT	16	GY	1661709C1						
CAV	CIRCUIT	GAUGE	COLOR	TERMINAL																																											
1	A92GG	18	TN	1661709C1																																											
2	A94ST	14	GY	1661709C1																																											
3	-	-	-	-																																											
4	A94KP	18	TN	1661709C1																																											
5	A94VT	16	GY	1661709C1																																											
<p>CONNECTOR 0593385C1 BODY LOCK 0593387C1</p>																																															
<p><b>ABS XMSN INTERRUPT (1085M)</b></p> 																																															
<table border="1" style="width: 100%; border-collapse: collapse;"> <thead> <tr> <th>CAV</th> <th>CIRCUIT</th> <th>GAUGE</th> <th>COLOR</th> <th>TERMINAL</th> <th>SEAL/SLEEVE</th> </tr> </thead> <tbody> <tr> <td>A</td> <td>A94KP</td> <td>18</td> <td>TN</td> <td>0587576C1</td> <td>1652325C1</td> </tr> <tr> <td>B</td> <td>A92-GG</td> <td>18</td> <td>TN</td> <td>0587576C1</td> <td>1652325C1</td> </tr> </tbody> </table>												CAV	CIRCUIT	GAUGE	COLOR	TERMINAL	SEAL/SLEEVE	A	A94KP	18	TN	0587576C1	1652325C1	B	A92-GG	18	TN	0587576C1	1652325C1																		
CAV	CIRCUIT	GAUGE	COLOR	TERMINAL	SEAL/SLEEVE																																										
A	A94KP	18	TN	0587576C1	1652325C1																																										
B	A92-GG	18	TN	0587576C1	1652325C1																																										
<p>CONNECTOR 0587568C91</p>																																															
<p><b>RETARDER ON LIGHT (1087M)</b></p> 																																															
<table border="1" style="width: 100%; border-collapse: collapse;"> <thead> <tr> <th>CAV</th> <th>CIRCUIT</th> <th>GAUGE</th> <th>COLOR</th> <th>TERMINAL</th> </tr> </thead> <tbody> <tr> <td>A</td> <td>A13BP</td> <td>18</td> <td>PK</td> <td>0333732C1</td> </tr> <tr> <td>B</td> <td>A92RR</td> <td>18</td> <td>TN</td> <td>0333732C1</td> </tr> </tbody> </table>												CAV	CIRCUIT	GAUGE	COLOR	TERMINAL	A	A13BP	18	PK	0333732C1	B	A92RR	18	TN	0333732C1																					
CAV	CIRCUIT	GAUGE	COLOR	TERMINAL																																											
A	A13BP	18	PK	0333732C1																																											
B	A92RR	18	TN	0333732C1																																											
<p>CONNECTOR 0969541R1</p>																																															
				<p><b>CIGAR LIGHTER (1090F / 1090M)</b></p>																																											
<p>CONNECTOR 1661199C1</p>				<p>CONNECTOR 1661198C1</p>																																											
<table border="1" style="width: 100%; border-collapse: collapse;"> <thead> <tr> <th>CAV</th> <th>CIRCUIT</th> <th>GAUGE</th> <th>COLOR</th> <th>TERMINAL</th> </tr> </thead> <tbody> <tr> <td>A</td> <td>A62AA</td> <td>16</td> <td>DKBL</td> <td>1661212C1</td> </tr> <tr> <td>B</td> <td>A84H</td> <td>14</td> <td>LTGN</td> <td>3534167C1</td> </tr> <tr> <td>C</td> <td>A84-GH</td> <td>16</td> <td>WH</td> <td>1661212C1</td> </tr> </tbody> </table>				CAV	CIRCUIT	GAUGE	COLOR	TERMINAL	A	A62AA	16	DKBL	1661212C1	B	A84H	14	LTGN	3534167C1	C	A84-GH	16	WH	1661212C1	<table border="1" style="width: 100%; border-collapse: collapse;"> <thead> <tr> <th>CAV</th> <th>CIRCUIT</th> <th>GAUGE</th> <th>COLOR</th> <th>TERMINAL</th> </tr> </thead> <tbody> <tr> <td>A</td> <td>A62T</td> <td>16</td> <td>DKBL</td> <td>1661209C1</td> </tr> <tr> <td>B</td> <td>A84</td> <td>14</td> <td>LTGN</td> <td>3566715C1</td> </tr> <tr> <td>C</td> <td>A84-G</td> <td>16</td> <td>WH</td> <td>1661209C1</td> </tr> </tbody> </table>				CAV	CIRCUIT	GAUGE	COLOR	TERMINAL	A	A62T	16	DKBL	1661209C1	B	A84	14	LTGN	3566715C1	C	A84-G	16	WH	1661209C1
CAV	CIRCUIT	GAUGE	COLOR	TERMINAL																																											
A	A62AA	16	DKBL	1661212C1																																											
B	A84H	14	LTGN	3534167C1																																											
C	A84-GH	16	WH	1661212C1																																											
CAV	CIRCUIT	GAUGE	COLOR	TERMINAL																																											
A	A62T	16	DKBL	1661209C1																																											
B	A84	14	LTGN	3566715C1																																											
C	A84-G	16	WH	1661209C1																																											
<p><b>J1939 ALLISON DIAG (1095F)</b></p> 																																															
<table border="1" style="width: 100%; border-collapse: collapse;"> <thead> <tr> <th>CAV</th> <th>CIRCUIT</th> <th>GAUGE</th> <th>COLOR</th> <th>TERMINAL</th> </tr> </thead> <tbody> <tr> <td>A</td> <td>K98YL5</td> <td>18</td> <td>YL</td> <td>1680205C1</td> </tr> <tr> <td>B</td> <td>K98GN5</td> <td>18</td> <td>GN</td> <td>1680205C1</td> </tr> <tr> <td>C</td> <td>PLUG</td> <td>-</td> <td>-</td> <td>0453133C1</td> </tr> </tbody> </table>												CAV	CIRCUIT	GAUGE	COLOR	TERMINAL	A	K98YL5	18	YL	1680205C1	B	K98GN5	18	GN	1680205C1	C	PLUG	-	-	0453133C1																
CAV	CIRCUIT	GAUGE	COLOR	TERMINAL																																											
A	K98YL5	18	YL	1680205C1																																											
B	K98GN5	18	GN	1680205C1																																											
C	PLUG	-	-	0453133C1																																											
<p>CONNECTOR 3601919C1 BODY LOCK 3601921C1</p>																																															
CHK	DATE	CHANGE	REV	REFERENCE	DRAWN	NAME																																									
MJVO	13MAR16	R/D 1090F/1090M WAS	B	93408S	300371	CIRCUIT DIAGRAM, PAYSTAR																																									
1090.					RELEASE NO.	DATE	PART NO.	SHEET																																							
					61879Y	17SEP09	AE08058092	087																																							

Figure 294 Connector Composites (1065M / 1085M / 1087M / 1090 / 1095F)



13.108. CONNECTOR COMPOSITES (1095F / 1097 / 1097F / 1098F), P. 88

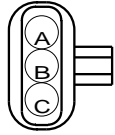
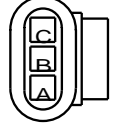
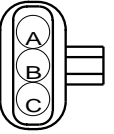
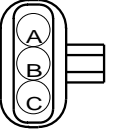
<b>NAVISTAR, INC</b> <small>THIS PRINT IS PROVIDED ON A RESTRICTED BASIS AND IS NOT TO BE USED IN ANY WAY DETRIMENTAL TO THE INTEREST OF NAVISTAR, INC.</small>				ELECTRICAL CIRCUIT DIAGRAM <b>CHAPTER 13</b> CONNECTOR BODY COMPOSITE - MATING VIEW SHOWN																																																																																																	
<b>ALLISON DIAG (1095F)</b> 																																																																																																					
CONNECTOR 1667740C1 BODY LOCK 1667771C1																																																																																																					
<table border="1" style="width:100%; border-collapse: collapse;"> <thead> <tr> <th>CAV</th> <th>CIRCUIT</th> <th>GAUGE</th> <th>COLOR</th> <th>TERMINAL</th> <th>SEAL/SLEEVE</th> </tr> </thead> <tbody> <tr> <td>A</td> <td>K98YL5</td> <td>18</td> <td>YL</td> <td>1667742C1</td> <td>3568570C1</td> </tr> <tr> <td>B</td> <td>K98GN5</td> <td>18</td> <td>GN</td> <td>1667742C1</td> <td>3568570C1</td> </tr> </tbody> </table>						CAV	CIRCUIT	GAUGE	COLOR	TERMINAL	SEAL/SLEEVE	A	K98YL5	18	YL	1667742C1	3568570C1	B	K98GN5	18	GN	1667742C1	3568570C1																																																																														
CAV	CIRCUIT	GAUGE	COLOR	TERMINAL	SEAL/SLEEVE																																																																																																
A	K98YL5	18	YL	1667742C1	3568570C1																																																																																																
B	K98GN5	18	GN	1667742C1	3568570C1																																																																																																
<b>J1939 BACKBONE (1097)</b> 																																																																																																					
CONNECTOR 1667741C1 BODY LOCK 1667771C1																																																																																																					
<table border="1" style="width:100%; border-collapse: collapse;"> <thead> <tr> <th>CAV</th> <th>CIRCUIT</th> <th>GAUGE</th> <th>COLOR</th> <th>TERMINAL</th> <th>SEAL/SLEEVE</th> </tr> </thead> <tbody> <tr> <td>A*</td> <td>K98YL1</td> <td>18</td> <td>YL</td> <td>1661875C1</td> <td>3568570C1</td> </tr> <tr> <td>A#</td> <td>K5R(+)</td> <td>18</td> <td>YL</td> <td>1661875C1</td> <td>3568570C1</td> </tr> <tr> <td>B</td> <td>PLUG</td> <td>-</td> <td>-</td> <td>2025431C1</td> <td>-</td> </tr> <tr> <td>C*</td> <td>K98GN1</td> <td>18</td> <td>GN</td> <td>1661875C1</td> <td>3568570C1</td> </tr> <tr> <td>C#</td> <td>K5R(-)</td> <td>18</td> <td>GN</td> <td>1661875C1</td> <td>3568570C1</td> </tr> </tbody> </table> <p style="font-size: small;">* W/ ALLISON XMSN # W/ AUTOSHIFT, ULTRASHIFT &amp; FREEDOMLINE XMSN</p>						CAV	CIRCUIT	GAUGE	COLOR	TERMINAL	SEAL/SLEEVE	A*	K98YL1	18	YL	1661875C1	3568570C1	A#	K5R(+)	18	YL	1661875C1	3568570C1	B	PLUG	-	-	2025431C1	-	C*	K98GN1	18	GN	1661875C1	3568570C1	C#	K5R(-)	18	GN	1661875C1	3568570C1																																																												
CAV	CIRCUIT	GAUGE	COLOR	TERMINAL	SEAL/SLEEVE																																																																																																
A*	K98YL1	18	YL	1661875C1	3568570C1																																																																																																
A#	K5R(+)	18	YL	1661875C1	3568570C1																																																																																																
B	PLUG	-	-	2025431C1	-																																																																																																
C*	K98GN1	18	GN	1661875C1	3568570C1																																																																																																
C#	K5R(-)	18	GN	1661875C1	3568570C1																																																																																																
<b>J1939 ENGINE DATALINK (1097F)</b> 																																																																																																					
CONNECTOR 1667740C1 BODY LOCK 1667771C1																																																																																																					
<table border="1" style="width:100%; border-collapse: collapse;"> <thead> <tr> <th>CAV</th> <th>CIRCUIT</th> <th>GAUGE</th> <th>COLOR</th> <th>TERMINAL</th> <th>SEAL/SLEEVE</th> </tr> </thead> <tbody> <tr> <td>A</td> <td>YL1(+)</td> <td>18</td> <td>YL</td> <td>1667742C1</td> <td>3568570C1</td> </tr> <tr> <td>B</td> <td>PLUG</td> <td>-</td> <td>-</td> <td>2025431C1</td> <td>-</td> </tr> <tr> <td>C</td> <td>GN1(-)</td> <td>18</td> <td>GN</td> <td>1667742C1</td> <td>3568570C1</td> </tr> </tbody> </table> <p style="font-size: x-small;">W/ ABS</p> <table border="1" style="width:100%; border-collapse: collapse;"> <thead> <tr> <th>CAV</th> <th>CIRCUIT</th> <th>GAUGE</th> <th>COLOR</th> <th>TERMINAL</th> <th>SEAL/SLEEVE</th> </tr> </thead> <tbody> <tr> <td>A</td> <td>K98YL1</td> <td>18</td> <td>YL</td> <td>1661875C1</td> <td>3568570C1</td> </tr> <tr> <td>B</td> <td>PLUG</td> <td>-</td> <td>-</td> <td>2025431C1</td> <td>-</td> </tr> <tr> <td>C</td> <td>K98GN1</td> <td>18</td> <td>GN</td> <td>1661875C1</td> <td>3568570C1</td> </tr> </tbody> </table> <p style="font-size: x-small;">W/ CUMMINS AHD &amp; ISM W/ CAT C10, C12 &amp; 3406E</p> <table border="1" style="width:100%; border-collapse: collapse;"> <thead> <tr> <th>CAV</th> <th>CIRCUIT</th> <th>GAUGE</th> <th>COLOR</th> <th>TERMINAL</th> <th>SEAL/SLEEVE</th> </tr> </thead> <tbody> <tr> <td>A</td> <td>98YL4(+)</td> <td>18</td> <td>YL</td> <td>1661875C1</td> <td>1661872C1</td> </tr> <tr> <td>B</td> <td>PLUG</td> <td>-</td> <td>-</td> <td>2025431C1</td> <td>-</td> </tr> <tr> <td>C</td> <td>98GN3(-)</td> <td>18</td> <td>GN</td> <td>1661875C1</td> <td>1661872C1</td> </tr> </tbody> </table> <p style="font-size: x-small;">W/ CUMMINS N14 DD 60 OR 80 SERIES</p> <table border="1" style="width:100%; border-collapse: collapse;"> <thead> <tr> <th>CAV</th> <th>CIRCUIT</th> <th>GAUGE</th> <th>COLOR</th> <th>TERMINAL</th> <th>SEAL/SLEEVE</th> </tr> </thead> <tbody> <tr> <td>A</td> <td>98YL1(+)</td> <td>18</td> <td>YL</td> <td>1667742C1</td> <td>1661872C1</td> </tr> <tr> <td>B</td> <td>PLUG</td> <td>-</td> <td>-</td> <td>2025431C1</td> <td>-</td> </tr> <tr> <td>C</td> <td>98GN1(-)</td> <td>18</td> <td>GN</td> <td>1667742C1</td> <td>1661872C1</td> </tr> </tbody> </table>						CAV	CIRCUIT	GAUGE	COLOR	TERMINAL	SEAL/SLEEVE	A	YL1(+)	18	YL	1667742C1	3568570C1	B	PLUG	-	-	2025431C1	-	C	GN1(-)	18	GN	1667742C1	3568570C1	CAV	CIRCUIT	GAUGE	COLOR	TERMINAL	SEAL/SLEEVE	A	K98YL1	18	YL	1661875C1	3568570C1	B	PLUG	-	-	2025431C1	-	C	K98GN1	18	GN	1661875C1	3568570C1	CAV	CIRCUIT	GAUGE	COLOR	TERMINAL	SEAL/SLEEVE	A	98YL4(+)	18	YL	1661875C1	1661872C1	B	PLUG	-	-	2025431C1	-	C	98GN3(-)	18	GN	1661875C1	1661872C1	CAV	CIRCUIT	GAUGE	COLOR	TERMINAL	SEAL/SLEEVE	A	98YL1(+)	18	YL	1667742C1	1661872C1	B	PLUG	-	-	2025431C1	-	C	98GN1(-)	18	GN	1667742C1	1661872C1
CAV	CIRCUIT	GAUGE	COLOR	TERMINAL	SEAL/SLEEVE																																																																																																
A	YL1(+)	18	YL	1667742C1	3568570C1																																																																																																
B	PLUG	-	-	2025431C1	-																																																																																																
C	GN1(-)	18	GN	1667742C1	3568570C1																																																																																																
CAV	CIRCUIT	GAUGE	COLOR	TERMINAL	SEAL/SLEEVE																																																																																																
A	K98YL1	18	YL	1661875C1	3568570C1																																																																																																
B	PLUG	-	-	2025431C1	-																																																																																																
C	K98GN1	18	GN	1661875C1	3568570C1																																																																																																
CAV	CIRCUIT	GAUGE	COLOR	TERMINAL	SEAL/SLEEVE																																																																																																
A	98YL4(+)	18	YL	1661875C1	1661872C1																																																																																																
B	PLUG	-	-	2025431C1	-																																																																																																
C	98GN3(-)	18	GN	1661875C1	1661872C1																																																																																																
CAV	CIRCUIT	GAUGE	COLOR	TERMINAL	SEAL/SLEEVE																																																																																																
A	98YL1(+)	18	YL	1667742C1	1661872C1																																																																																																
B	PLUG	-	-	2025431C1	-																																																																																																
C	98GN1(-)	18	GN	1667742C1	1661872C1																																																																																																
<b>J1939 DATALINK (1098F)</b> 																																																																																																					
CONNECTOR 1667740C1 BODY LOCK 1667771C1																																																																																																					
<table border="1" style="width:100%; border-collapse: collapse;"> <thead> <tr> <th>CAV</th> <th>CIRCUIT</th> <th>GAUGE</th> <th>COLOR</th> <th>TERMINAL</th> <th>SEAL/SLEEVE</th> </tr> </thead> <tbody> <tr> <td>A</td> <td>A98YL1(+)</td> <td>20</td> <td>YL</td> <td>1667742C1</td> <td>1661872C1</td> </tr> <tr> <td>B</td> <td>N98SHD1</td> <td>20</td> <td>NONE</td> <td>1667742C1</td> <td>1661872C1</td> </tr> <tr> <td>C</td> <td>A98GN1(-)</td> <td>20</td> <td>GN</td> <td>1667742C1</td> <td>1661872C1</td> </tr> </tbody> </table>						CAV	CIRCUIT	GAUGE	COLOR	TERMINAL	SEAL/SLEEVE	A	A98YL1(+)	20	YL	1667742C1	1661872C1	B	N98SHD1	20	NONE	1667742C1	1661872C1	C	A98GN1(-)	20	GN	1667742C1	1661872C1																																																																								
CAV	CIRCUIT	GAUGE	COLOR	TERMINAL	SEAL/SLEEVE																																																																																																
A	A98YL1(+)	20	YL	1667742C1	1661872C1																																																																																																
B	N98SHD1	20	NONE	1667742C1	1661872C1																																																																																																
C	A98GN1(-)	20	GN	1667742C1	1661872C1																																																																																																
CHK	DATE	CHANGE	REV	REFERENCE	DRAWN	NAME																																																																																															
012	17APR13	ADDED R/D 1095F.	B	91786V	300371	CIRCUIT DIAGRAM, PAYSTAR																																																																																															
					RELEASE NO.	DATE																																																																																															
					61879Y	17SEP09																																																																																															
					PART NO.	SHEET																																																																																															
					AE08058092	088																																																																																															

Figure 295 Connector Composites (1095F / 1097 / 1097F / 1098F)

13.109. CONNECTOR COMPOSITES (1099 / 1110 / 1125 / 1126), P. 89

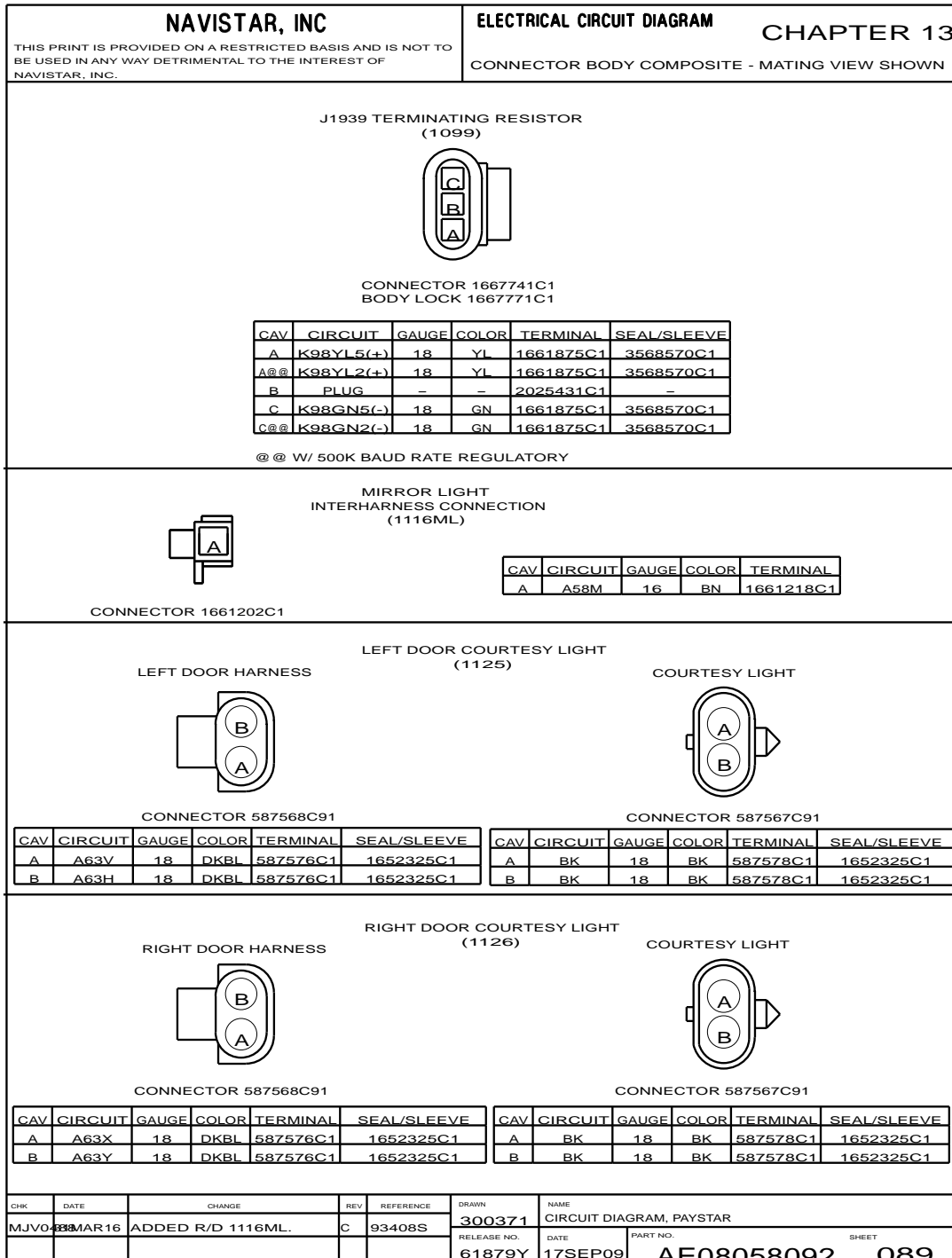


Figure 296 Connector Composites (1099 / 1110 / 1125 / 1126)

13.110. CONNECTOR COMPOSITES (1127 / 1128), P. 90

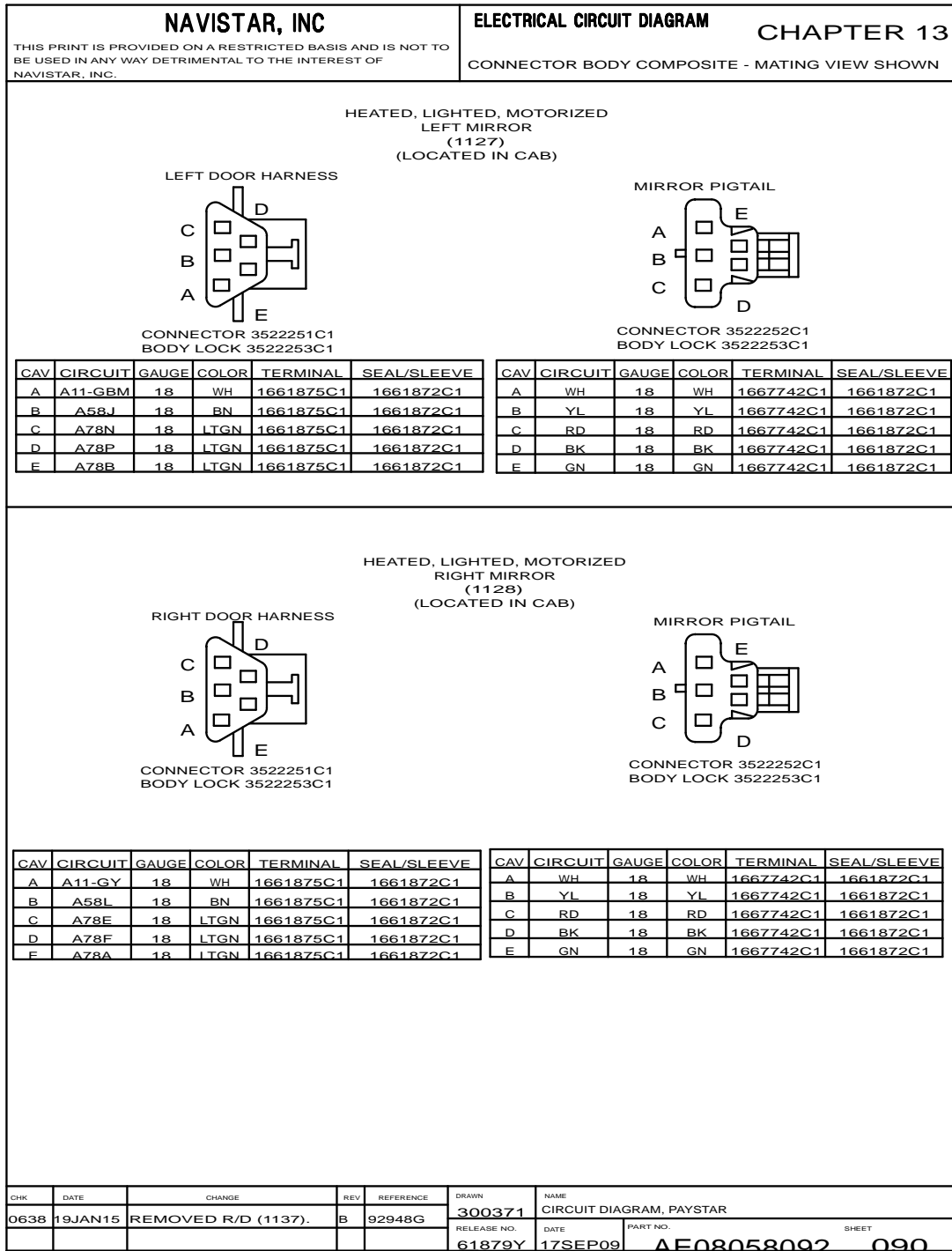


Figure 297 Connector Composites (1127 / 1128)

13.111. CONNECTOR COMPOSITES (1135M / 1137), P. 90A

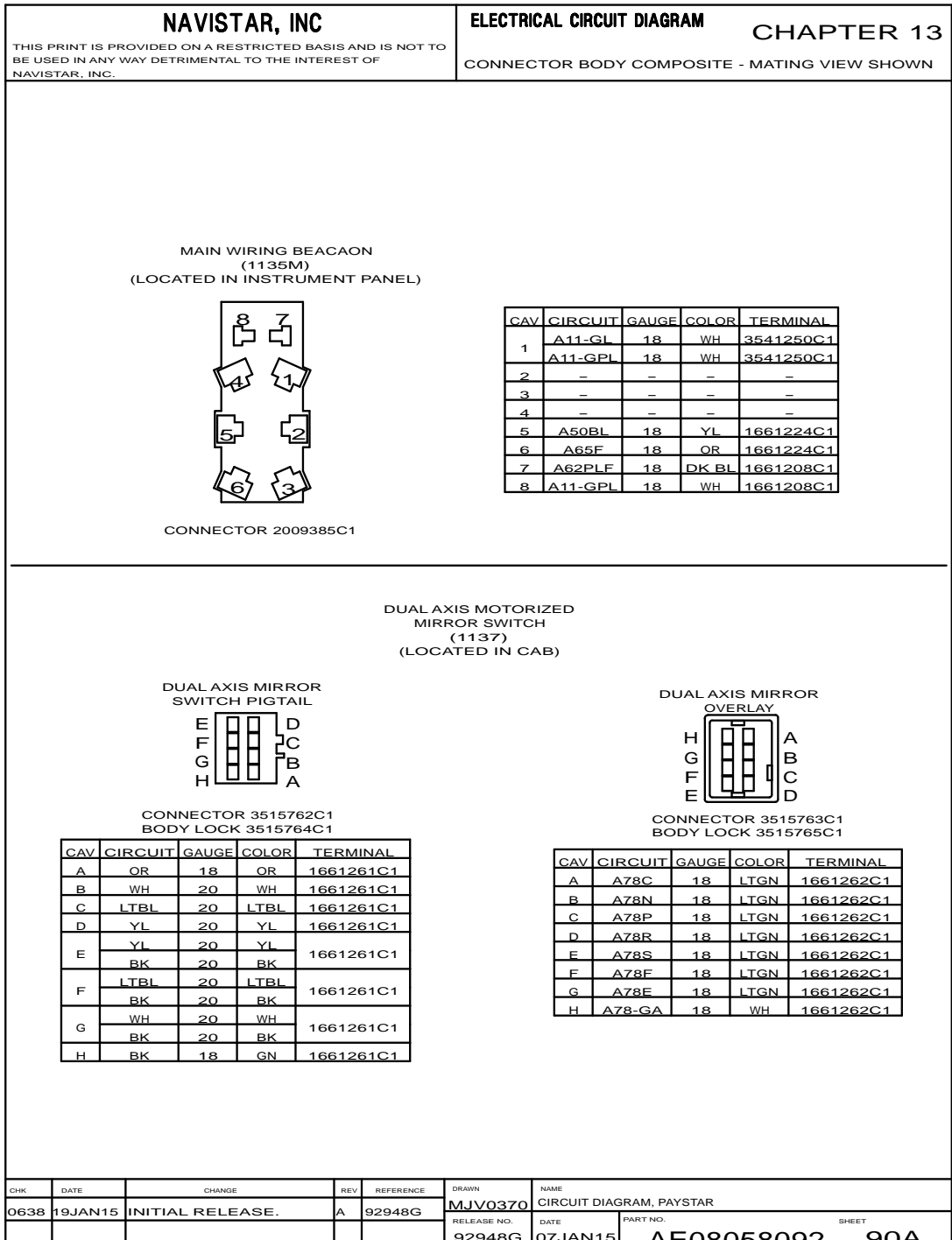


Figure 298 Connector Composites (1135M / 1137)

13.112. CONNECTOR COMPOSITES (1157F / 1158M / 1160F / 1161F, 1162F, 1163F, 1164F), P. 91

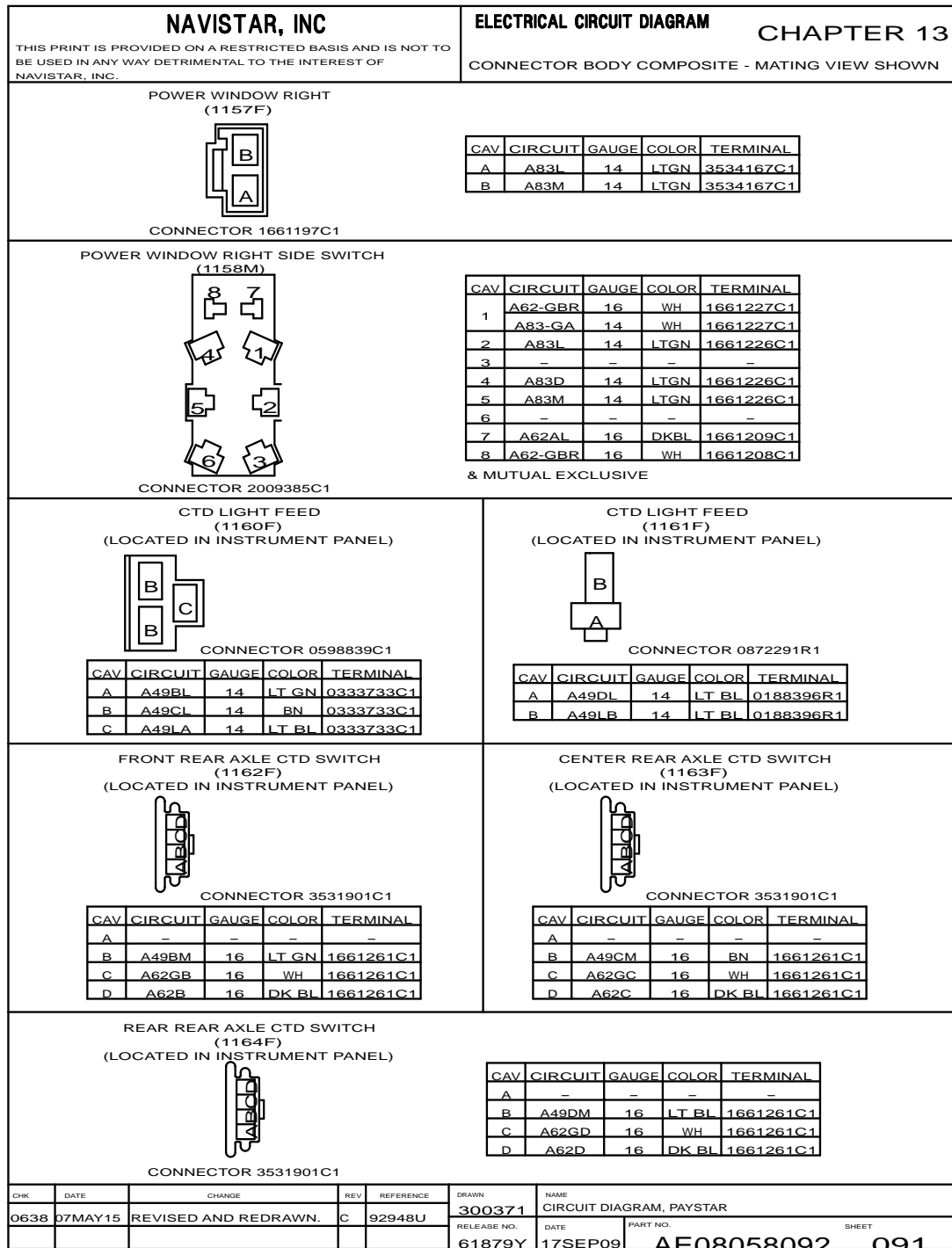


Figure 299 Connector Composites (1157F / 1158M / 1160F / 1161F, 1162F, 1163F, 1164F)

13.113. CONNECTOR COMPOSITE (1171M / 1190 / 1190F), P. 91A

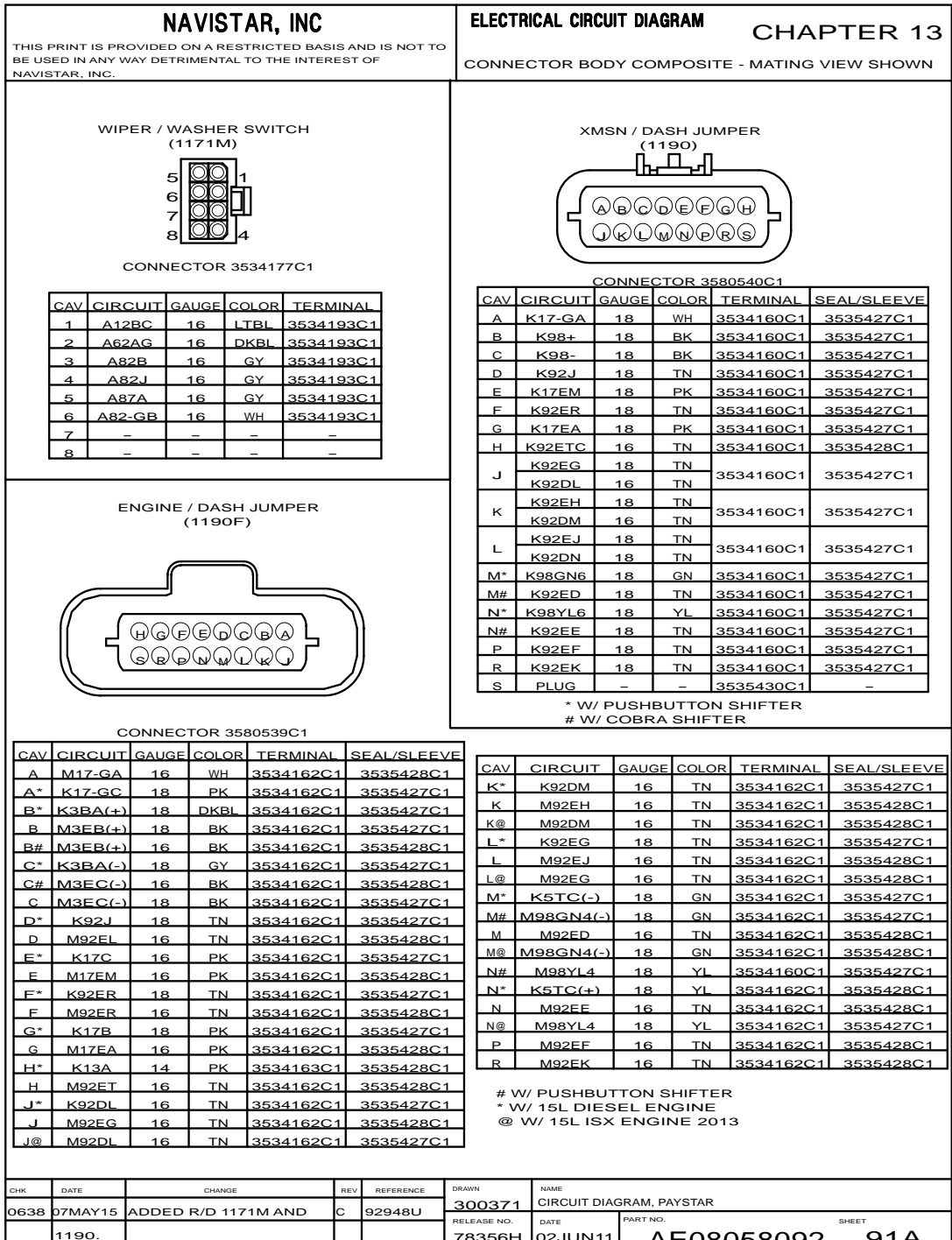


Figure 300 Connector Composite (1171M / 1190 / 1190F)

13.114. CONNECTOR COMPOSITES (1217M / 1240 / 1258F / 1260F / 1262), P. 92

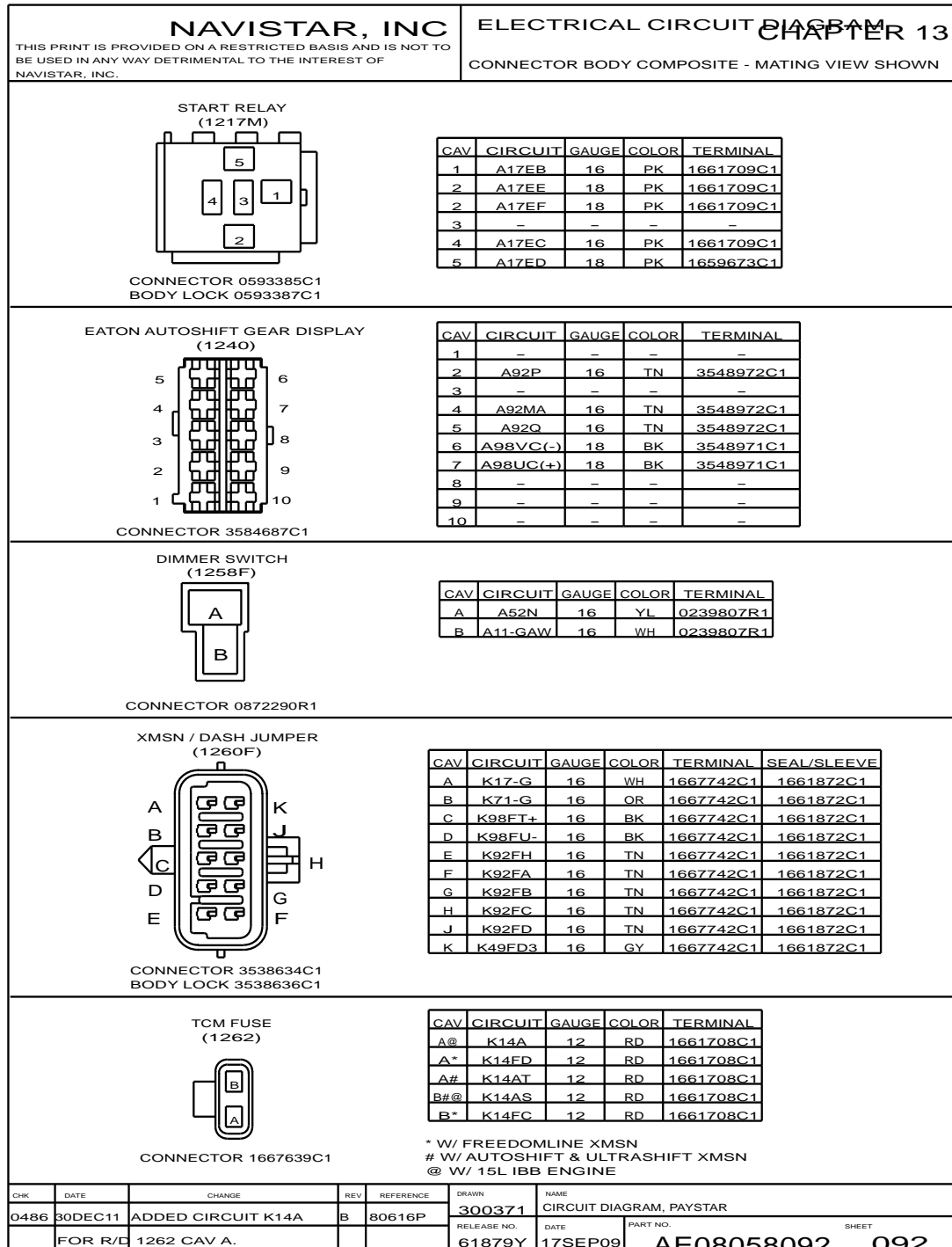


Figure 301 Connector Composites (1217M / 1240 / 1258F / 1260F / 1262)

13.115. CONNECTOR COMPOSITES (1281M / 1282M / 1283 / 1284 / 1285F), P. 93

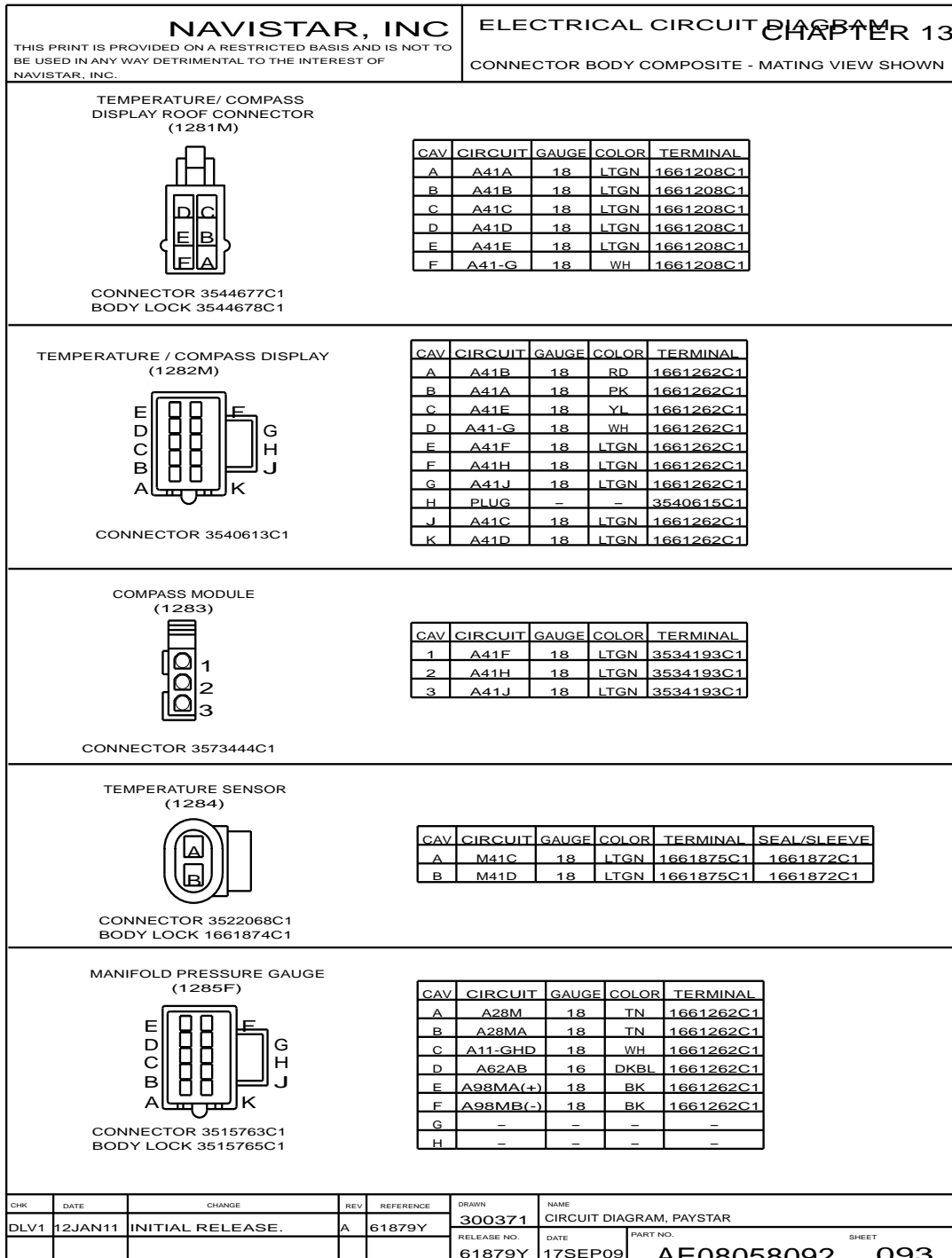


Figure 302 Connector Composites (1281M / 1282M / 1283 / 1284 / 1285F)



13.116. CONNECTOR COMPOSITES (1286F / 1308 / 1309M / 1329M / 1330 / 1331F / 1332F), P. 94

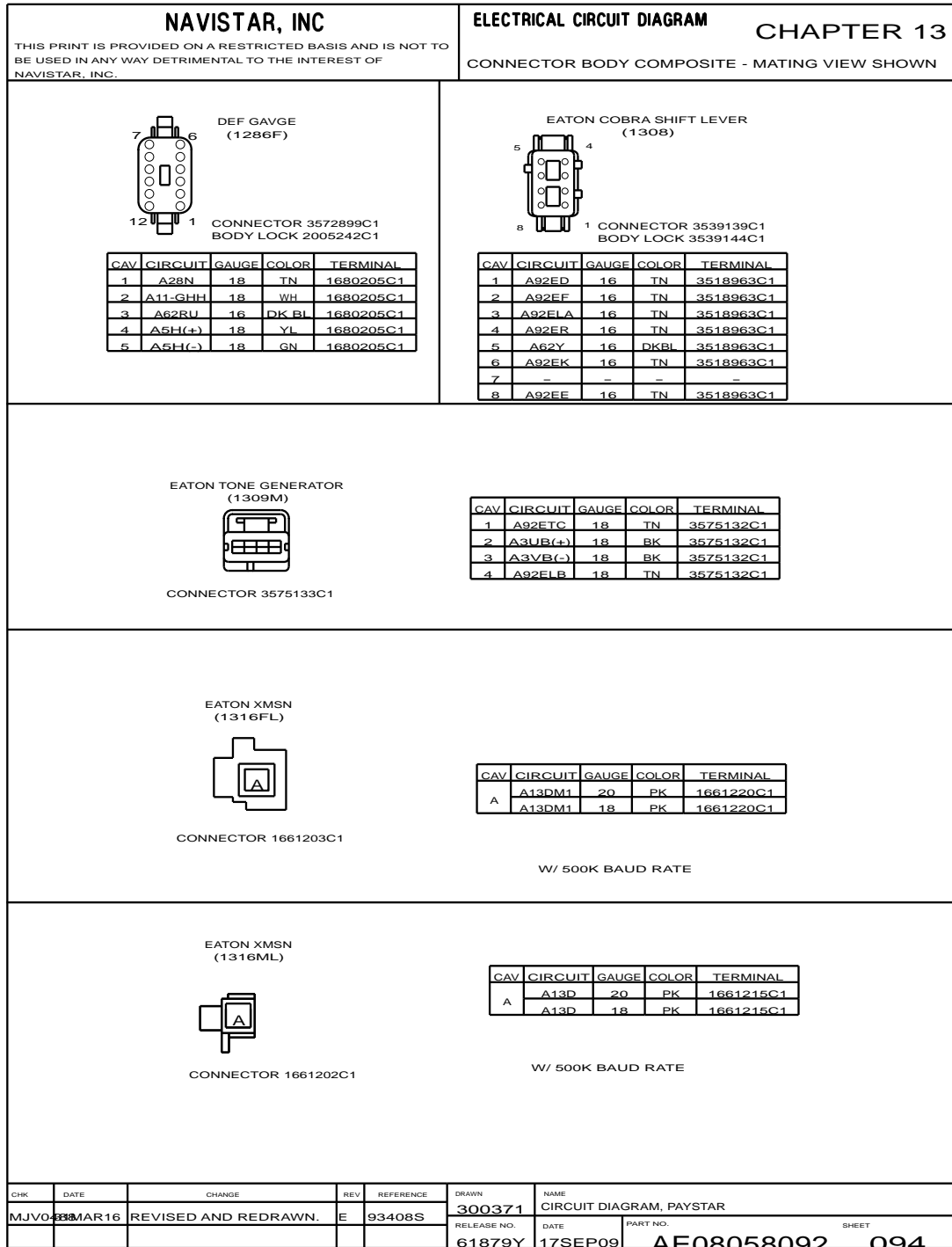


Figure 303 Connector Composites (1286F / 1308 / 1309M / 1329M / 1330 / 1331F / 1332F)

13.117. CONNECTOR COMPOSITES (1329M / 1330 / 1331F / 1332F), P. 94A





<b>NAVISTAR, INC</b>				<b>ELECTRICAL CIRCUIT DIAGRAM</b>		<b>CHAPTER 13</b>																																																							
THIS PRINT IS PROVIDED ON A RESTRICTED BASIS AND IS NOT TO BE USED IN ANY WAY DETRIMENTAL TO THE INTEREST OF NAVISTAR, INC.				CONNECTOR BODY COMPOSITE - MATING VIEW SHOWN																																																									
<p>BUMPER MTD MARKER LIGHT (1329M)</p>  <p>CONNECTOR 1671610C1 BODY LOCK 1671608C1</p>				<table border="1" style="width: 100%; border-collapse: collapse; font-size: x-small;"> <thead> <tr> <th>CAV</th> <th>CIRCUIT</th> <th>GAUGE</th> <th>COLOR</th> <th>TERMINAL</th> <th>SEAL/SLEEVE</th> </tr> </thead> <tbody> <tr> <td>*A</td> <td>M58ML</td> <td>18</td> <td>BN</td> <td>2033819C1</td> <td>1652325C1</td> </tr> <tr> <td>#A</td> <td>M58ML</td> <td>18</td> <td>BN</td> <td>2033819C1</td> <td>1652325C1</td> </tr> <tr> <td>B</td> <td>M58-GML</td> <td>18</td> <td>WH</td> <td>2033819C1</td> <td>1652325C1</td> </tr> <tr> <td>*B</td> <td>M11-GML</td> <td>18</td> <td>WH</td> <td>2033819C1</td> <td>1652325C1</td> </tr> <tr> <td>#B</td> <td>M11-GML</td> <td>18</td> <td>WH</td> <td>2033819C1</td> <td>1652325C1</td> </tr> </tbody> </table> <p style="font-size: x-small; text-align: center;">* W/ 15L DIESEL ENGINE # W/ 15L ISX ENGINE 2013</p>				CAV	CIRCUIT	GAUGE	COLOR	TERMINAL	SEAL/SLEEVE	*A	M58ML	18	BN	2033819C1	1652325C1	#A	M58ML	18	BN	2033819C1	1652325C1	B	M58-GML	18	WH	2033819C1	1652325C1	*B	M11-GML	18	WH	2033819C1	1652325C1	#B	M11-GML	18	WH	2033819C1	1652325C1																		
CAV	CIRCUIT	GAUGE	COLOR	TERMINAL	SEAL/SLEEVE																																																								
*A	M58ML	18	BN	2033819C1	1652325C1																																																								
#A	M58ML	18	BN	2033819C1	1652325C1																																																								
B	M58-GML	18	WH	2033819C1	1652325C1																																																								
*B	M11-GML	18	WH	2033819C1	1652325C1																																																								
#B	M11-GML	18	WH	2033819C1	1652325C1																																																								
<p>SHAFT STOP (1330)</p>  <p>CONNECTOR 2009385C1</p>				<table border="1" style="width: 100%; border-collapse: collapse; font-size: x-small;"> <thead> <tr> <th>CAV</th> <th>CIRCUIT</th> <th>GAUGE</th> <th>COLOR</th> <th>TERMINAL</th> <th>SEAL/SLEEVE</th> </tr> </thead> <tbody> <tr><td>1</td><td>-</td><td>-</td><td>-</td><td>-</td><td>-</td></tr> <tr><td>2</td><td>-</td><td>-</td><td>-</td><td>-</td><td>-</td></tr> <tr><td>3</td><td>-</td><td>-</td><td>-</td><td>-</td><td>-</td></tr> <tr><td>4</td><td>-</td><td>-</td><td>-</td><td>-</td><td>-</td></tr> <tr><td>5</td><td>A92TM</td><td>18</td><td>TN</td><td>1661224C1</td><td></td></tr> <tr><td>6</td><td>A92TN</td><td>18</td><td>TN</td><td>1661224C1</td><td></td></tr> <tr><td>7</td><td>A62SD</td><td>18</td><td>LTR</td><td>1661208C1</td><td></td></tr> <tr><td>8</td><td>A92-GA</td><td>18</td><td>WH</td><td>1661208C1</td><td></td></tr> </tbody> </table>				CAV	CIRCUIT	GAUGE	COLOR	TERMINAL	SEAL/SLEEVE	1	-	-	-	-	-	2	-	-	-	-	-	3	-	-	-	-	-	4	-	-	-	-	-	5	A92TM	18	TN	1661224C1		6	A92TN	18	TN	1661224C1		7	A62SD	18	LTR	1661208C1		8	A92-GA	18	WH	1661208C1	
CAV	CIRCUIT	GAUGE	COLOR	TERMINAL	SEAL/SLEEVE																																																								
1	-	-	-	-	-																																																								
2	-	-	-	-	-																																																								
3	-	-	-	-	-																																																								
4	-	-	-	-	-																																																								
5	A92TM	18	TN	1661224C1																																																									
6	A92TN	18	TN	1661224C1																																																									
7	A62SD	18	LTR	1661208C1																																																									
8	A92-GA	18	WH	1661208C1																																																									
<p>DRIVERS HEATED SEAT CONNECTOR (1331F)</p>  <p>CONNECTOR 0587567C91</p>				<table border="1" style="width: 100%; border-collapse: collapse; font-size: x-small;"> <thead> <tr> <th>CAV</th> <th>CIRCUIT</th> <th>GAUGE</th> <th>COLOR</th> <th>TERMINAL</th> <th>SEAL/SLEEVE</th> </tr> </thead> <tbody> <tr> <td>A</td> <td>WHITE</td> <td>18</td> <td>WH</td> <td>0587578C1</td> <td>1652325C1</td> </tr> <tr> <td>B</td> <td>BLACK</td> <td>18</td> <td>BK</td> <td>0587578C1</td> <td>1652325C1</td> </tr> </tbody> </table>				CAV	CIRCUIT	GAUGE	COLOR	TERMINAL	SEAL/SLEEVE	A	WHITE	18	WH	0587578C1	1652325C1	B	BLACK	18	BK	0587578C1	1652325C1																																				
CAV	CIRCUIT	GAUGE	COLOR	TERMINAL	SEAL/SLEEVE																																																								
A	WHITE	18	WH	0587578C1	1652325C1																																																								
B	BLACK	18	BK	0587578C1	1652325C1																																																								
<p>PASSENGERS HEATED SEAT CONNECTOR (1332F)</p>  <p>CONNECTOR 0587567C91</p>				<table border="1" style="width: 100%; border-collapse: collapse; font-size: x-small;"> <thead> <tr> <th>CAV</th> <th>CIRCUIT</th> <th>GAUGE</th> <th>COLOR</th> <th>TERMINAL</th> <th>SEAL/SLEEVE</th> </tr> </thead> <tbody> <tr> <td>A</td> <td>A38</td> <td>18</td> <td>WH</td> <td>0587578C1</td> <td>1652325C1</td> </tr> <tr> <td>B</td> <td>A38</td> <td>18</td> <td>RD</td> <td>0587578C1</td> <td>1652325C1</td> </tr> </tbody> </table>				CAV	CIRCUIT	GAUGE	COLOR	TERMINAL	SEAL/SLEEVE	A	A38	18	WH	0587578C1	1652325C1	B	A38	18	RD	0587578C1	1652325C1																																				
CAV	CIRCUIT	GAUGE	COLOR	TERMINAL	SEAL/SLEEVE																																																								
A	A38	18	WH	0587578C1	1652325C1																																																								
B	A38	18	RD	0587578C1	1652325C1																																																								
CHK	DATE	CHANGE	REV	REFERENCE	DRAWN	NAME																																																							
MJVO	13MAR16	INITIAL RELEASE.	A	93408S	MJV0223	CIRCUIT DIAGRAM, PAYSTAR																																																							
RELEASE NO.		DATE		PART NO.		SHEET																																																							
93408S		20JAN16		AE08058092		94A																																																							

Figure 304 Connector Composites (1329M / 1330 / 1331F / 1332F)

13.118. CONNECTOR COMPOSITES (1339 / 1342 / 1348), P. 95

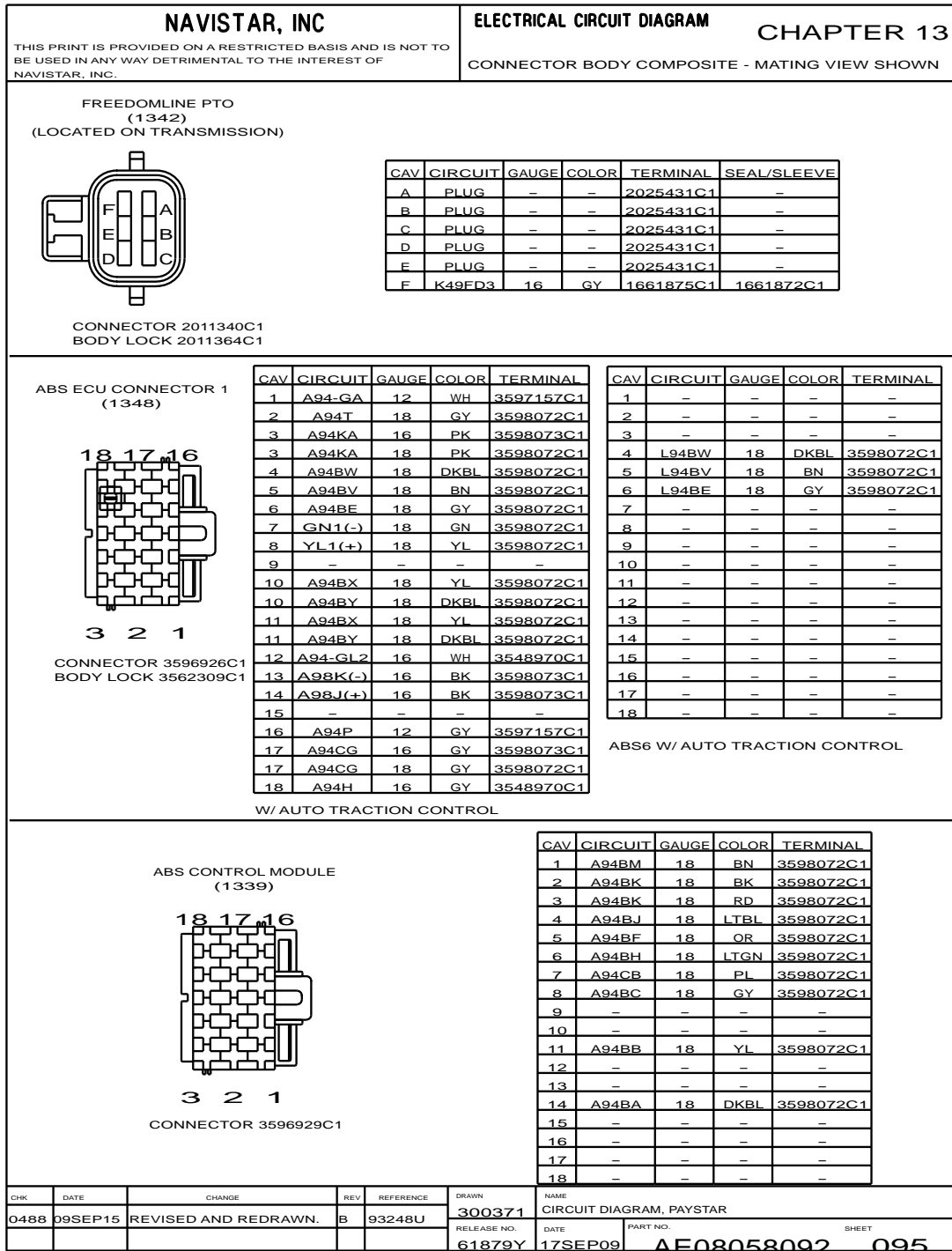


Figure 305 Connector Composites (1339 / 1342 / 1348)

13.119. CONNECTOR COMPOSITES (1349 / 1350), P. 96

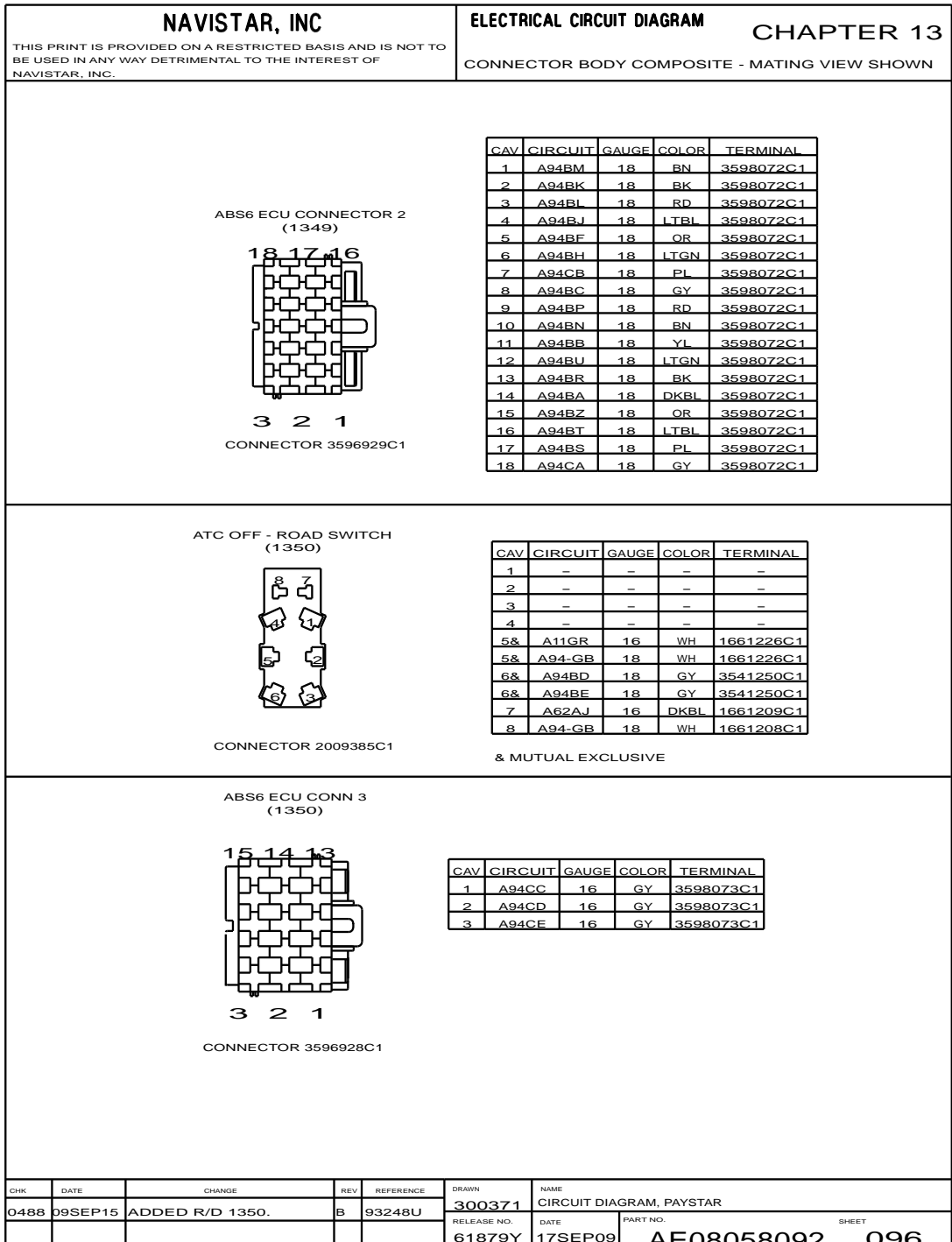


Figure 306 Connector Composites (1349 / 1350)

13.120. CONNECTOR COMPOSITES (1351 / 1360), P. 96A

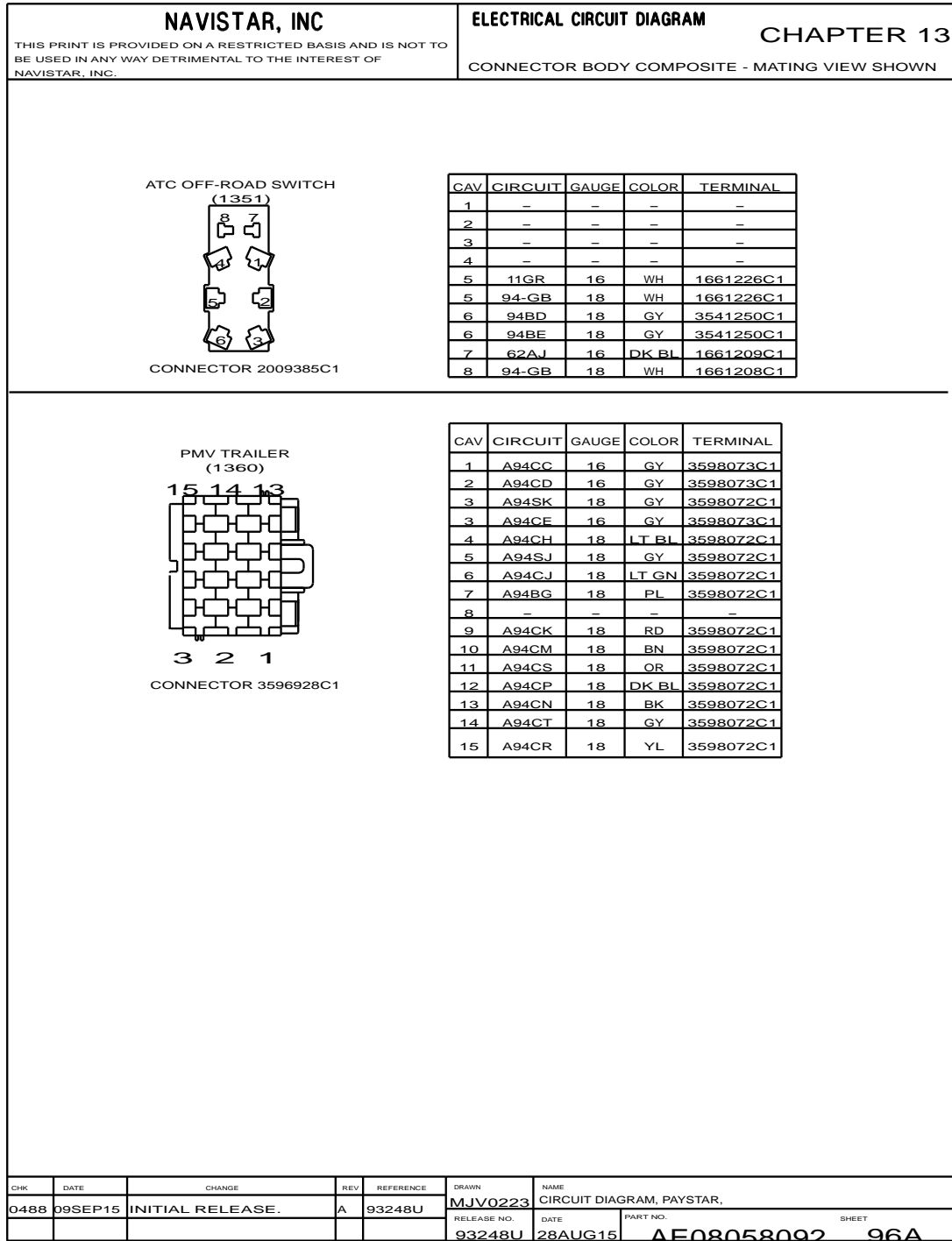


Figure 307 Connector Composites (1351 / 1360)

13.121. CONNECTOR COMPOSITES (1361 / 1363 / 1364), P. 97

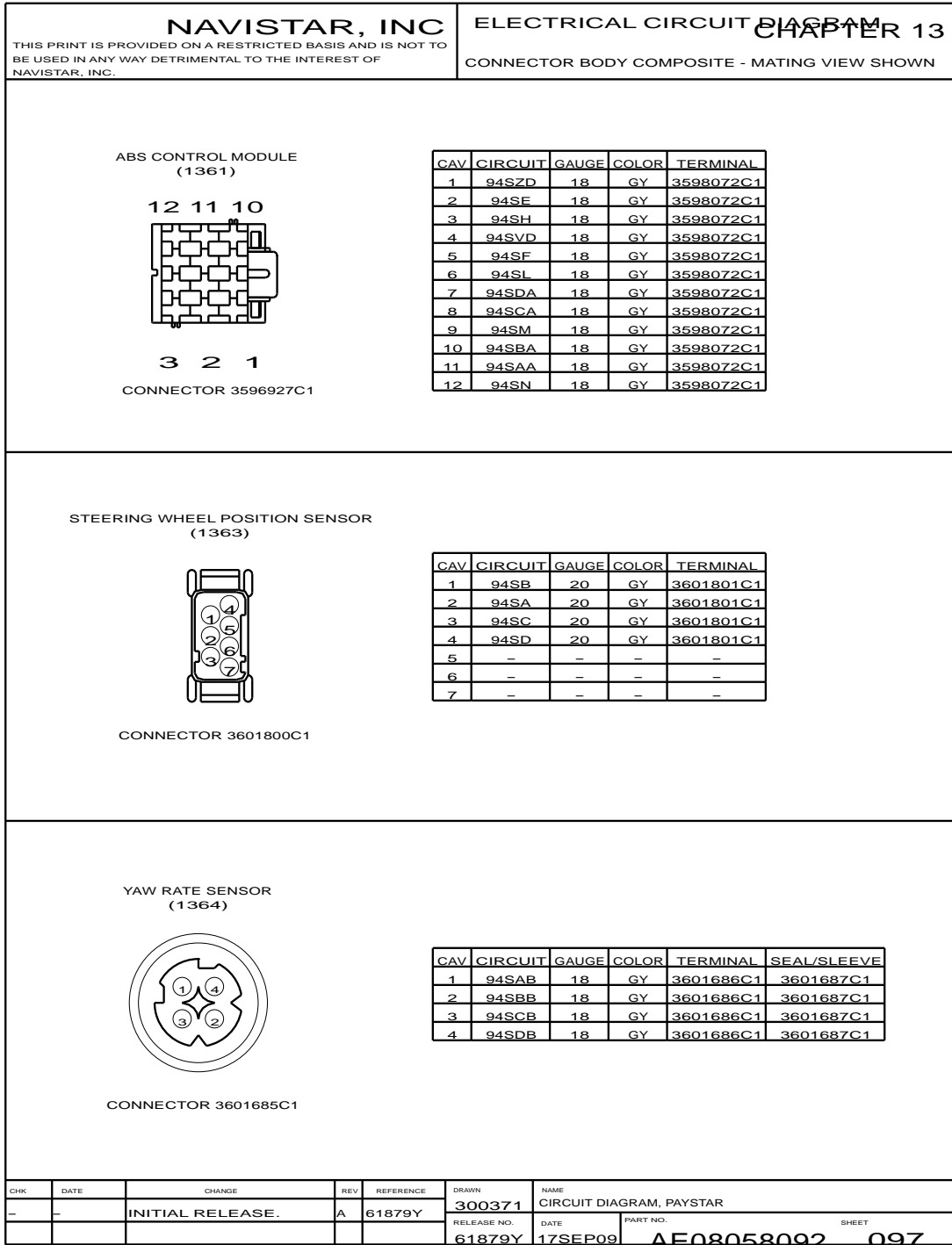


Figure 308 Connector Composites (1361 / 1363 / 1364)

13.122. CONNECTOR COMPOSITES (1366 / 1367 / 1368F / 1369), P. 98

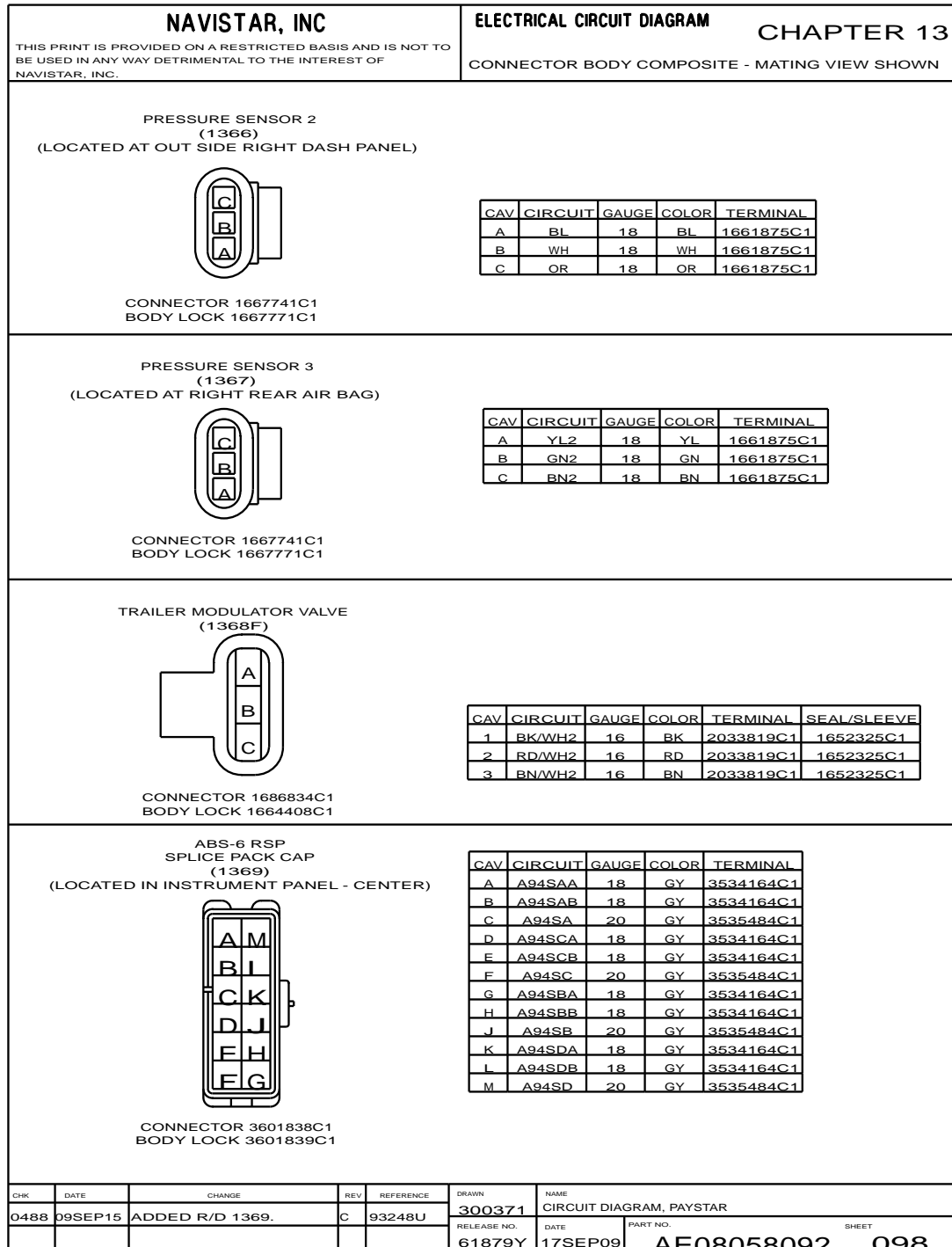


Figure 309 Connector Composites (1366 / 1367 / 1368F / 1369)

13.123. CONNECTOR COMPOSITES (1370 / 1378 / 1386 / 1387), P. 99

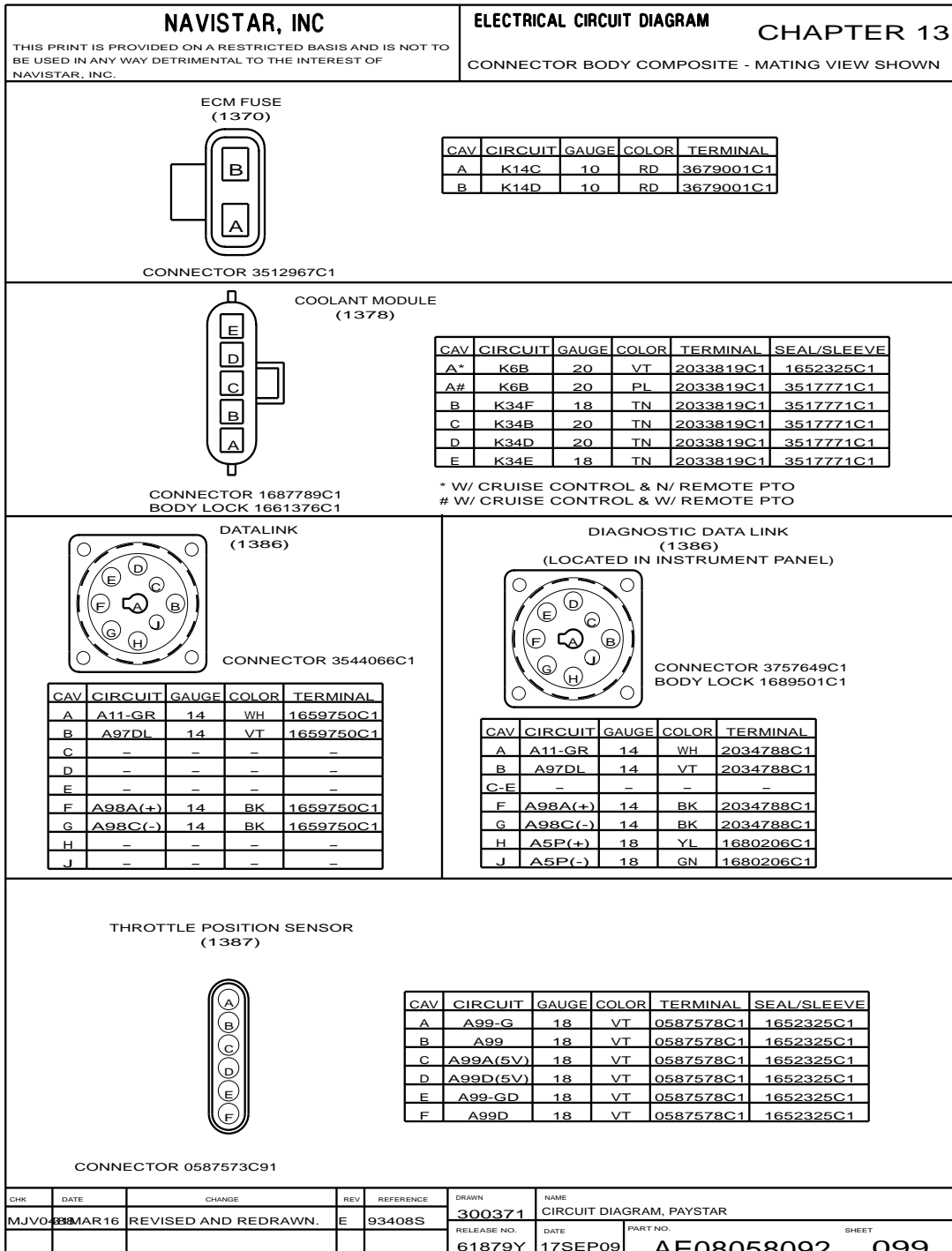


Figure 310 Connector Composites (1370 / 1378 / 1386 / 1387)



13.124. CONNECTOR COMPOSITES (1402 / 1403 / 1404 / 1405), P. 99A

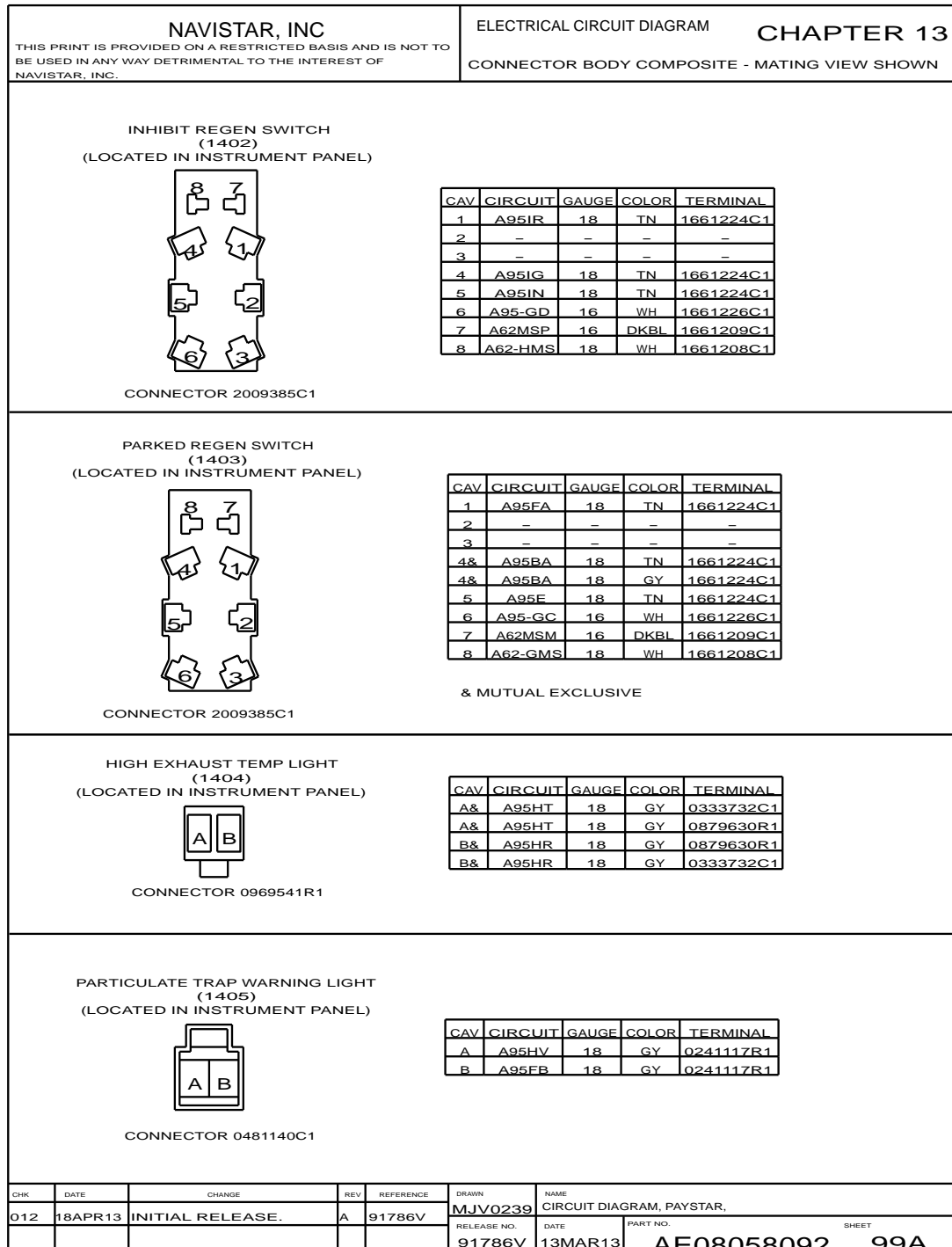


Figure 311 Connector Composites (1402 / 1403 / 1404 / 1405)

13.125. CONNECTOR COMPOSITES (1406 / 1407 / 1415), P. 99B

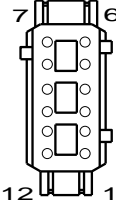
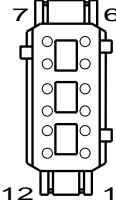
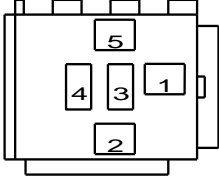
<b>NAVISTAR, INC</b> <small>THIS PRINT IS PROVIDED ON A RESTRICTED BASIS AND IS NOT TO BE USED IN ANY WAY DETRIMENTAL TO THE INTEREST OF NAVISTAR, INC.</small>				ELECTRICAL CIRCUIT DIAGRAM <b>CHAPTER 13</b> CONNECTOR BODY COMPOSITE - MATING VIEW SHOWN																																																																		
<p>J1 MULTIPLEXED SIGNAL MODULE (1406) (LOCATED IN INSTRUMENT PANEL)</p>  <p>CONNECTOR 3553404C1 BODY LOCK 3553460C1</p>		<table border="1" style="width: 100%; border-collapse: collapse;"> <thead> <tr> <th>CAV</th> <th>CIRCUIT</th> <th>GAUGE</th> <th>COLOR</th> <th>TERMINAL</th> </tr> </thead> <tbody> <tr><td>1</td><td>A95BM</td><td>18</td><td>TN</td><td>3518963C1</td></tr> <tr><td>2</td><td>A95IN</td><td>18</td><td>TN</td><td>3518963C1</td></tr> <tr><td>3</td><td>A95E</td><td>18</td><td>TN</td><td>3518963C1</td></tr> <tr><td>4</td><td>PLUG</td><td>-</td><td>-</td><td>3527276C1</td></tr> <tr><td>5</td><td>A6YL(+)</td><td>18</td><td>YL</td><td>3518963C1</td></tr> <tr><td>6</td><td>A6GN(-)</td><td>18</td><td>GN</td><td>3518963C1</td></tr> <tr><td>7</td><td>A95A</td><td>18</td><td>TN</td><td>3518963C1</td></tr> <tr><td>8</td><td>A95-GA</td><td>16</td><td>WH</td><td>3518963C1</td></tr> <tr><td>9</td><td>PLUG</td><td>-</td><td>-</td><td>3527276C1</td></tr> <tr><td>10</td><td>PLUG</td><td>-</td><td>-</td><td>3527276C1</td></tr> <tr><td>11</td><td>PLUG</td><td>-</td><td>-</td><td>3527276C1</td></tr> <tr><td>12</td><td>PLUG</td><td>-</td><td>-</td><td>3527276C1</td></tr> </tbody> </table>				CAV	CIRCUIT	GAUGE	COLOR	TERMINAL	1	A95BM	18	TN	3518963C1	2	A95IN	18	TN	3518963C1	3	A95E	18	TN	3518963C1	4	PLUG	-	-	3527276C1	5	A6YL(+)	18	YL	3518963C1	6	A6GN(-)	18	GN	3518963C1	7	A95A	18	TN	3518963C1	8	A95-GA	16	WH	3518963C1	9	PLUG	-	-	3527276C1	10	PLUG	-	-	3527276C1	11	PLUG	-	-	3527276C1	12	PLUG	-	-	3527276C1
CAV	CIRCUIT	GAUGE	COLOR	TERMINAL																																																																		
1	A95BM	18	TN	3518963C1																																																																		
2	A95IN	18	TN	3518963C1																																																																		
3	A95E	18	TN	3518963C1																																																																		
4	PLUG	-	-	3527276C1																																																																		
5	A6YL(+)	18	YL	3518963C1																																																																		
6	A6GN(-)	18	GN	3518963C1																																																																		
7	A95A	18	TN	3518963C1																																																																		
8	A95-GA	16	WH	3518963C1																																																																		
9	PLUG	-	-	3527276C1																																																																		
10	PLUG	-	-	3527276C1																																																																		
11	PLUG	-	-	3527276C1																																																																		
12	PLUG	-	-	3527276C1																																																																		
<p>J2 MULTIPLEXED SIGNAL MODULE (1407) (LOCATED IN INSTRUMENT PANEL)</p>  <p>CONNECTOR 3586750C1 BODY LOCK 3553460C1</p>		<table border="1" style="width: 100%; border-collapse: collapse;"> <thead> <tr> <th>CAV</th> <th>CIRCUIT</th> <th>GAUGE</th> <th>COLOR</th> <th>TERMINAL</th> </tr> </thead> <tbody> <tr><td>1</td><td>PLUG</td><td>-</td><td>-</td><td>3527276C1</td></tr> <tr><td>2</td><td>PLUG</td><td>-</td><td>-</td><td>3527276C1</td></tr> <tr><td>3</td><td>PLUG</td><td>-</td><td>-</td><td>3527276C1</td></tr> <tr><td>4</td><td>A95FA</td><td>18</td><td>TN</td><td>3518963C1</td></tr> <tr><td>5</td><td>A95IR</td><td>18</td><td>TN</td><td>3518963C1</td></tr> <tr><td>6</td><td>A95HR</td><td>18</td><td>GY</td><td>3518963C1</td></tr> <tr><td>7</td><td>A95FB</td><td>18</td><td>GY</td><td>3518963C1</td></tr> <tr><td>8</td><td>PLUG</td><td>-</td><td>-</td><td>3527276C1</td></tr> <tr><td>9</td><td>PLUG</td><td>-</td><td>-</td><td>3527276C1</td></tr> <tr><td>10</td><td>PLUG</td><td>-</td><td>-</td><td>3527276C1</td></tr> <tr><td>11</td><td>PLUG</td><td>-</td><td>-</td><td>3527276C1</td></tr> <tr><td>12</td><td>PLUG</td><td>-</td><td>-</td><td>3527276C1</td></tr> </tbody> </table>				CAV	CIRCUIT	GAUGE	COLOR	TERMINAL	1	PLUG	-	-	3527276C1	2	PLUG	-	-	3527276C1	3	PLUG	-	-	3527276C1	4	A95FA	18	TN	3518963C1	5	A95IR	18	TN	3518963C1	6	A95HR	18	GY	3518963C1	7	A95FB	18	GY	3518963C1	8	PLUG	-	-	3527276C1	9	PLUG	-	-	3527276C1	10	PLUG	-	-	3527276C1	11	PLUG	-	-	3527276C1	12	PLUG	-	-	3527276C1
CAV	CIRCUIT	GAUGE	COLOR	TERMINAL																																																																		
1	PLUG	-	-	3527276C1																																																																		
2	PLUG	-	-	3527276C1																																																																		
3	PLUG	-	-	3527276C1																																																																		
4	A95FA	18	TN	3518963C1																																																																		
5	A95IR	18	TN	3518963C1																																																																		
6	A95HR	18	GY	3518963C1																																																																		
7	A95FB	18	GY	3518963C1																																																																		
8	PLUG	-	-	3527276C1																																																																		
9	PLUG	-	-	3527276C1																																																																		
10	PLUG	-	-	3527276C1																																																																		
11	PLUG	-	-	3527276C1																																																																		
12	PLUG	-	-	3527276C1																																																																		
<p>AFTERTREATMENT BUZZER (1415) (LOCATED IN INSTRUMENT PANEL)</p>  <p>CONNECTOR 0593385C1 BODY LOCK 0593387C1</p>		<table border="1" style="width: 100%; border-collapse: collapse;"> <thead> <tr> <th>CAV</th> <th>CIRCUIT</th> <th>GAUGE</th> <th>COLOR</th> <th>TERMINAL</th> </tr> </thead> <tbody> <tr><td>1</td><td>A95BM</td><td>18</td><td>TN</td><td>1659673C1</td></tr> <tr><td>2</td><td>-</td><td>-</td><td>-</td><td>-</td></tr> <tr><td>3</td><td>A95BZ</td><td>18</td><td>TN</td><td>1659673C1</td></tr> <tr><td>4</td><td>-</td><td>-</td><td>-</td><td>-</td></tr> <tr><td>5</td><td>-</td><td>-</td><td>-</td><td>-</td></tr> </tbody> </table>				CAV	CIRCUIT	GAUGE	COLOR	TERMINAL	1	A95BM	18	TN	1659673C1	2	-	-	-	-	3	A95BZ	18	TN	1659673C1	4	-	-	-	-	5	-	-	-	-																																			
CAV	CIRCUIT	GAUGE	COLOR	TERMINAL																																																																		
1	A95BM	18	TN	1659673C1																																																																		
2	-	-	-	-																																																																		
3	A95BZ	18	TN	1659673C1																																																																		
4	-	-	-	-																																																																		
5	-	-	-	-																																																																		
CHK	DATE	CHANGE	REV	REFERENCE	DRAWN	NAME																																																																
012	18APR13	INITIAL RELEASE.	A	91786V	MJV0239	CIRCUIT DIAGRAM, PAYSTAR,																																																																
					RELEASE NO.	DATE	PART NO.																																																															
					91786V	13MAR13	AE08058092																																																															
							SHEET 99B																																																															

Figure 312 Connector Composites (1406 / 1407 / 1415)

13.126. CONNECTOR COMPOSITES (1431 / 1449F / 1449M / 1450 / 1451 / 1455 / 1456 / 1461M / 1610), P. 99C

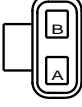

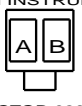
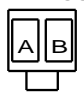




NAVISTAR, INC					ELECTRICAL CIRCUIT DIAGRAM				
THIS PRINT IS PROVIDED ON A RESTRICTED BASIS AND IS NOT TO BE USED IN ANY WAY DETRIMENTAL TO THE INTEREST OF NAVISTAR, INC.					CHAPTER 13				
					CONNECTOR BODY COMPOSITE - MATING VIEW SHOWN				
PURGE PUMP FUSE (1431) (LOCATED IN ENGINE) 					ROOF WIRING (1449F) (LOCATED IN INSTRUMENT PANEL) 				
CONNECTOR 1661639C1					CONNECTOR 0481140C1				
CAV	CIRCUIT	GAUGE	COLOR	TERMINAL	CAV	CIRCUIT	GAUGE	COLOR	TERMINAL
A	K14C	10	RD	2034787C1	A	C11-GBL	18	WH	0241117R1
B	K14D	10	RD	2034787C1	B	C65F	18	OR	0241117R1
MAIN WIRING BEACON (1449M) (LOCATED IN INSTRUMENT PANEL) 					ROOF WIRING (1450) (LOCATED IN ROOF PANEL) 				
CONNECTOR 0969541R1					CONNECTOR 1661259C1				
CAV	CIRCUIT	GAUGE	COLOR	TERMINAL	CAV	CIRCUIT	GAUGE	COLOR	TERMINAL
A	A11-GBL	18	WH	0333732C1	A	C11-GBR	18	WH	1661261C1
B	A65F	18	OR	0333732C1	B	C65FR	18	OR	1661261C1
ROOF WIRING (1451) (LOCATED IN ROOF PANEL) 					WAIT TO START (1455) (LOCATED IN INSTRUMENT PANEL) 				
CONNECTOR 1661259C1					CONNECTOR 1661260C1				
CAV	CIRCUIT	GAUGE	COLOR	TERMINAL	CAV	CIRCUIT	GAUGE	COLOR	TERMINAL
A	C11-GBT	18	WH	1661261C1	A	A97S	18	VT	1661262C1
B	C65FT	18	OR	1661261C1	B	A97WTS	18	VT	1661262C1
WATER IN FUEL (1456) (LOCATED IN INSTRUMENT PANEL) 					REMOTE AC CONDENSER (1461M) (LOCATED IN ENGINE) 				
CONNECTOR 1661259C1					CONNECTOR 0587568C91				
BODY LOCK 1661263C1									
CAV	CIRCUIT	GAUGE	COLOR	TERMINAL	CAV	CIRCUIT	GAUGE	COLOR	TERMINAL
A	A97F	18	VT	1661261C1	A	K23C	18	TN	0587576C1
B	A97WF	18	VT	1661261C1	B	K23AC	18	TN	0587576C1
CHK	DATE	CHANGE	REV	REFERENCE	DRAWN	NAME			
MJVO	13MAR16	RMVD R/D 1610.	C	93408S	MJV0239	CIRCUIT DIAGRAM, PAYSTAR			
					RELEASE NO.	DATE	PART NO.	SHEET	
					91786V	13MAR13	AE08058092	99C	

Figure 313 Connector Composites (1431 / 1449F / 1449M / 1450 / 1451 / 1455 / 1456 / 1461M / 1610)

13.127. CONNECTOR COMPOSITES (1600 / 1601), P. 99D

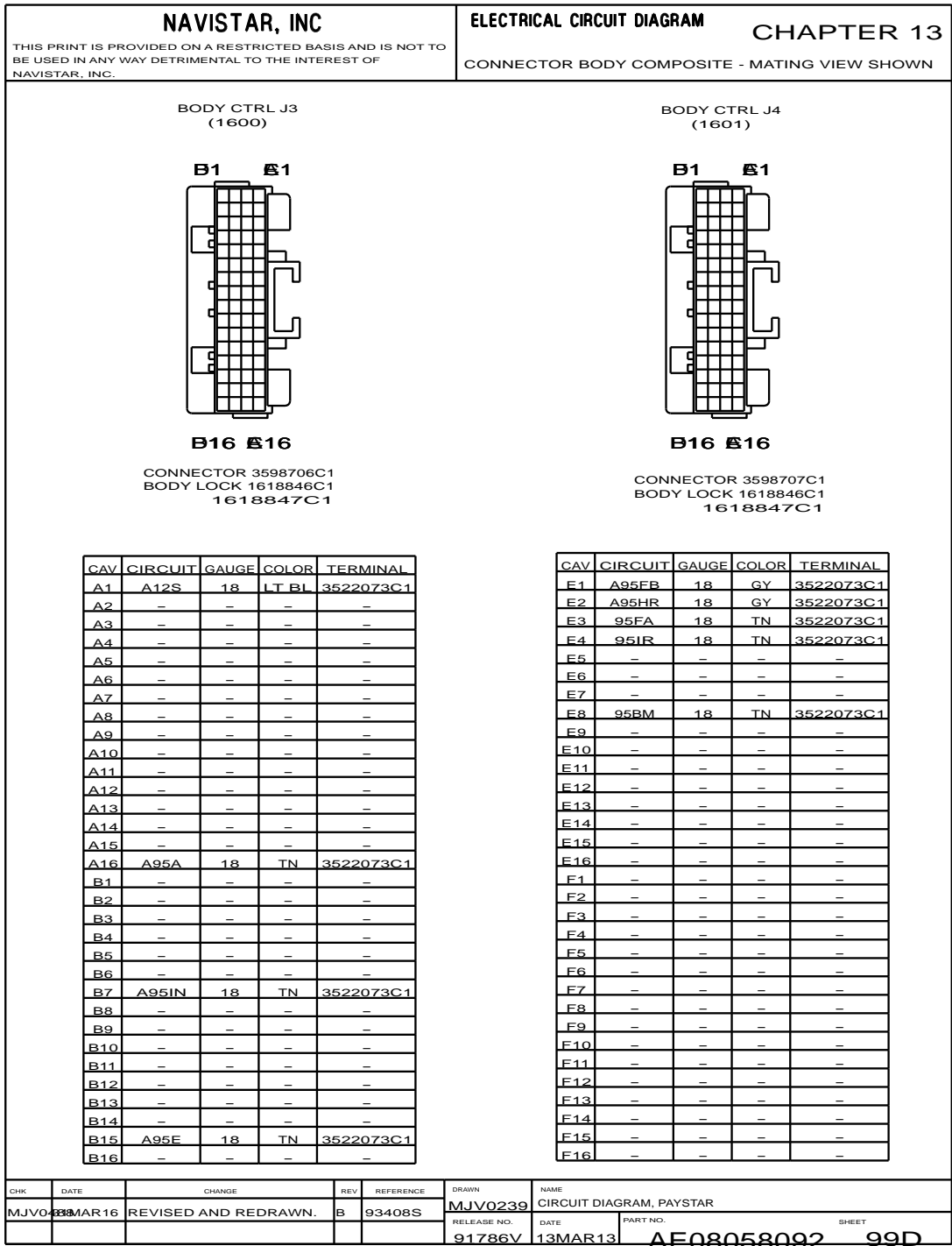


Figure 314 Connector Composites (1600 / 1601)

13.128. CONNECTOR COMPOSITES (1602 / 1604 / 1606 / 1610), P. 99E

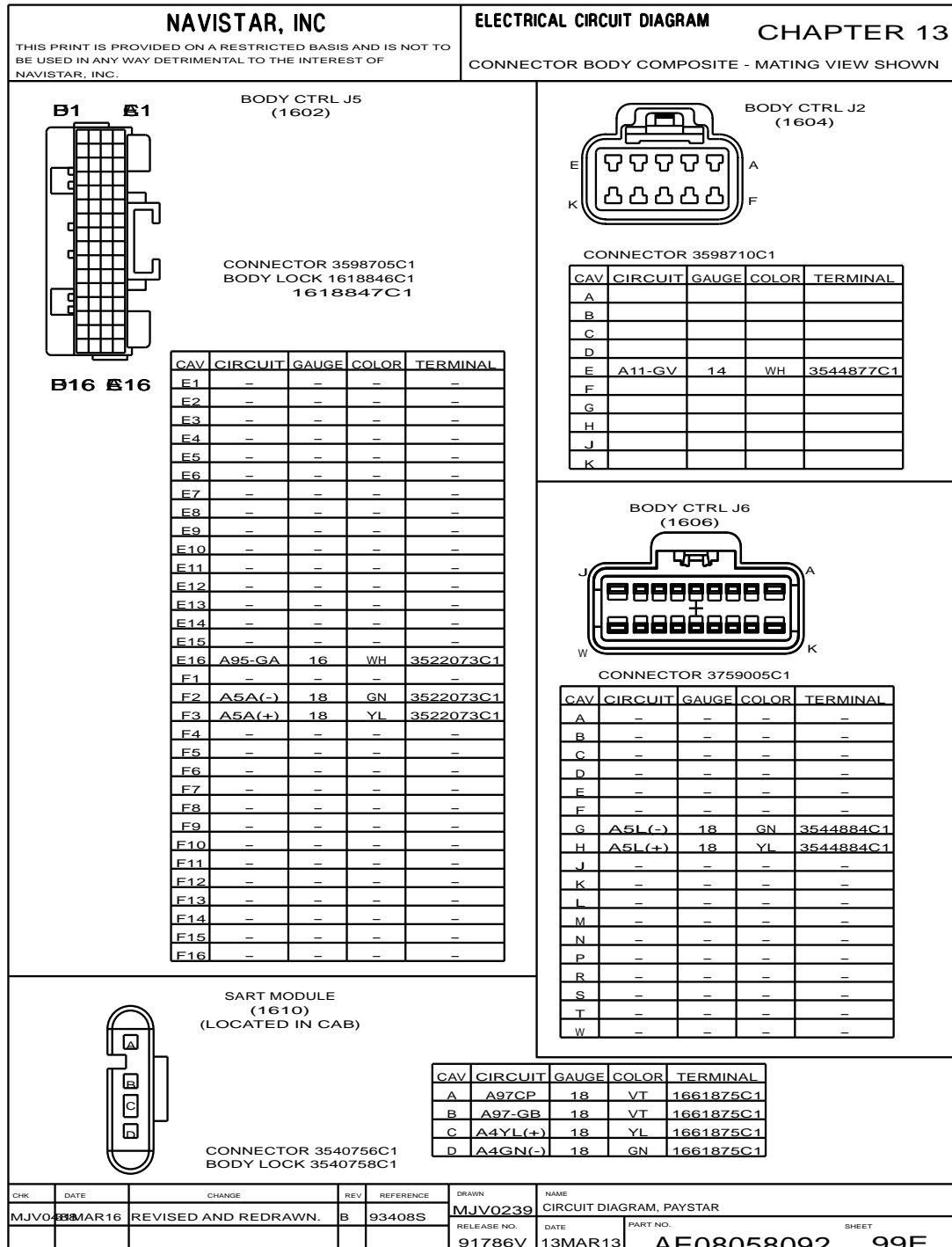


Figure 315 Connector Composites (1602 / 1604 / 1606 / 1610)

13.129. CONNECTOR COMPOSITES (1874A / 1874B / 1874C / 1874D / 2000M / 4322 / 4328), P. 99F




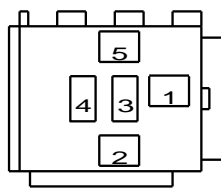


<b>NAVISTAR, INC</b>				<b>ELECTRICAL CIRCUIT DIAGRAM</b>				<b>CHAPTER 13</b>																																																			
THIS PRINT IS PROVIDED ON A RESTRICTED BASIS AND IS NOT TO BE USED IN ANY WAY DETRIMENTAL TO THE INTEREST OF NAVISTAR, INC.				CONNECTOR BODY COMPOSITE - MATING VIEW SHOWN																																																							
DAVCO WIF SENSOR (1874A)  CONNECTOR 3590390C1						RACOR WIF SENSOR (1874B) (LOCATED AT INSTRUMENT PANEL CENTER)  CONNECTOR 3590390C1																																																					
<table border="1" style="width:100%; border-collapse: collapse; font-size: x-small;"> <thead> <tr> <th>CAV</th> <th>CIRCUIT</th> <th>GAUGE</th> <th>COLOR</th> <th>TERMINAL</th> <th>SEAL/SLEEVE</th> </tr> </thead> <tbody> <tr> <td>1</td> <td>K95</td> <td>20</td> <td>TN</td> <td>3536865C1</td> <td>3536867C1</td> </tr> <tr> <td>2</td> <td>K95-GF</td> <td>18</td> <td>TN</td> <td>3536865C1</td> <td>3536868C1</td> </tr> </tbody> </table>						CAV	CIRCUIT	GAUGE	COLOR	TERMINAL	SEAL/SLEEVE	1	K95	20	TN	3536865C1	3536867C1	2	K95-GF	18	TN	3536865C1	3536868C1	<table border="1" style="width:100%; border-collapse: collapse; font-size: x-small;"> <thead> <tr> <th>CAV</th> <th>CIRCUIT</th> <th>GAUGE</th> <th>COLOR</th> <th>TERMINAL</th> <th>SEAL/SLEEVE</th> </tr> </thead> <tbody> <tr> <td>1</td> <td>K95W</td> <td>18</td> <td>TN</td> <td>3561584C1</td> <td>3536867C1</td> </tr> <tr> <td>1*</td> <td>K95W</td> <td>20</td> <td>TN</td> <td>3536865C1</td> <td>3536867C1</td> </tr> <tr> <td>2</td> <td>K95-GF</td> <td>18</td> <td>WH</td> <td>3561584C1</td> <td>3536867C1</td> </tr> <tr> <td>2*</td> <td>K95-GF</td> <td>18</td> <td>TN</td> <td>3561584C1</td> <td>3536868C1</td> </tr> </tbody> </table> <p style="text-align: center; font-size: x-small;">* W/ 15L ISX ENGINE</p>						CAV	CIRCUIT	GAUGE	COLOR	TERMINAL	SEAL/SLEEVE	1	K95W	18	TN	3561584C1	3536867C1	1*	K95W	20	TN	3536865C1	3536867C1	2	K95-GF	18	WH	3561584C1	3536867C1	2*	K95-GF	18	TN	3561584C1	3536868C1
CAV	CIRCUIT	GAUGE	COLOR	TERMINAL	SEAL/SLEEVE																																																						
1	K95	20	TN	3536865C1	3536867C1																																																						
2	K95-GF	18	TN	3536865C1	3536868C1																																																						
CAV	CIRCUIT	GAUGE	COLOR	TERMINAL	SEAL/SLEEVE																																																						
1	K95W	18	TN	3561584C1	3536867C1																																																						
1*	K95W	20	TN	3536865C1	3536867C1																																																						
2	K95-GF	18	WH	3561584C1	3536867C1																																																						
2*	K95-GF	18	TN	3561584C1	3536868C1																																																						
RAYCOR WIF SENSOR (1874C/1874D)  CONNECTOR 3977821C1						<table border="1" style="width:100%; border-collapse: collapse; font-size: x-small;"> <thead> <tr> <th>CAV</th> <th>CIRCUIT</th> <th>GAUGE</th> <th>COLOR</th> <th>TERMINAL</th> </tr> </thead> <tbody> <tr> <td>1</td> <td>K95</td> <td>18</td> <td>TN</td> <td>3526966C1</td> </tr> <tr> <td>2</td> <td>K95-GG</td> <td>18</td> <td>TN</td> <td>3526966C1</td> </tr> </tbody> </table>						CAV	CIRCUIT	GAUGE	COLOR	TERMINAL	1	K95	18	TN	3526966C1	2	K95-GG	18	TN	3526966C1																																	
CAV	CIRCUIT	GAUGE	COLOR	TERMINAL																																																							
1	K95	18	TN	3526966C1																																																							
2	K95-GG	18	TN	3526966C1																																																							
EATON ULTRASHIFT3 / DM3 XMSN RELAY (2000M)  CONNECTOR 0593385C1 BODY LOCK 0593387C1						<table border="1" style="width:100%; border-collapse: collapse; font-size: x-small;"> <thead> <tr> <th>CAV</th> <th>CIRCUIT</th> <th>GAUGE</th> <th>COLOR</th> <th>TERMINAL</th> </tr> </thead> <tbody> <tr> <td>1</td> <td>A13DM2</td> <td>18</td> <td>PK</td> <td>1659673C1</td> </tr> <tr> <td>2</td> <td>A92EH</td> <td>16</td> <td>TN</td> <td>1661710C1</td> </tr> <tr> <td>3</td> <td>A13D</td> <td>18</td> <td>PK</td> <td>1659673C1</td> </tr> <tr> <td>4</td> <td>A92EG</td> <td>16</td> <td>TN</td> <td>1661710C1</td> </tr> <tr> <td>5</td> <td>A92EJ</td> <td>16</td> <td>TN</td> <td>1661710C1</td> </tr> </tbody> </table>						CAV	CIRCUIT	GAUGE	COLOR	TERMINAL	1	A13DM2	18	PK	1659673C1	2	A92EH	16	TN	1661710C1	3	A13D	18	PK	1659673C1	4	A92EG	16	TN	1661710C1	5	A92EJ	16	TN	1661710C1																		
CAV	CIRCUIT	GAUGE	COLOR	TERMINAL																																																							
1	A13DM2	18	PK	1659673C1																																																							
2	A92EH	16	TN	1661710C1																																																							
3	A13D	18	PK	1659673C1																																																							
4	A92EG	16	TN	1661710C1																																																							
5	A92EJ	16	TN	1661710C1																																																							
FREEDOMLINE J1939 (4322)  CONNECTOR 3602454C1 BODY LOCK 1655705C1						PRIVATE J1939 (4328)  CONNECTOR 3602454C1 BODY LOCK 1655705C1																																																					
<table border="1" style="width:100%; border-collapse: collapse; font-size: x-small;"> <thead> <tr> <th>CAV</th> <th>CIRCUIT</th> <th>GAUGE</th> <th>COLOR</th> <th>TERMINAL</th> </tr> </thead> <tbody> <tr> <td>A</td> <td>K5V(+)</td> <td>18</td> <td>YL</td> <td>1680206C1</td> </tr> <tr> <td>B</td> <td>K5V(-)</td> <td>18</td> <td>GN</td> <td>1680206C1</td> </tr> <tr> <td>C</td> <td>PLUG</td> <td>-</td> <td>-</td> <td>0453133C1</td> </tr> </tbody> </table>						CAV	CIRCUIT	GAUGE	COLOR	TERMINAL	A	K5V(+)	18	YL	1680206C1	B	K5V(-)	18	GN	1680206C1	C	PLUG	-	-	0453133C1	<table border="1" style="width:100%; border-collapse: collapse; font-size: x-small;"> <thead> <tr> <th>CAV</th> <th>CIRCUIT</th> <th>GAUGE</th> <th>COLOR</th> <th>TERMINAL</th> </tr> </thead> <tbody> <tr> <td>A</td> <td>K98YL</td> <td>18</td> <td>YL</td> <td>1680206C1</td> </tr> <tr> <td>B</td> <td>K98GN</td> <td>18</td> <td>GN</td> <td>1680206C1</td> </tr> <tr> <td>C</td> <td>PLUG</td> <td>-</td> <td>-</td> <td>0453133C1</td> </tr> </tbody> </table>						CAV	CIRCUIT	GAUGE	COLOR	TERMINAL	A	K98YL	18	YL	1680206C1	B	K98GN	18	GN	1680206C1	C	PLUG	-	-	0453133C1								
CAV	CIRCUIT	GAUGE	COLOR	TERMINAL																																																							
A	K5V(+)	18	YL	1680206C1																																																							
B	K5V(-)	18	GN	1680206C1																																																							
C	PLUG	-	-	0453133C1																																																							
CAV	CIRCUIT	GAUGE	COLOR	TERMINAL																																																							
A	K98YL	18	YL	1680206C1																																																							
B	K98GN	18	GN	1680206C1																																																							
C	PLUG	-	-	0453133C1																																																							
CHK	DATE	CHANGE	REV	REFERENCE	DRAWN	NAME		CIRCUIT DIAGRAM, PAYSTAR																																																			
MJV0438	MAR16	INITIAL RELEASE.	A	93408S	MJV0223	RELEASE NO.	DATE	PART NO.	SHEET																																																		
					93408S	20JAN16	AE08058092	99F																																																			

Figure 316 Connector Composites (1874A / 1874B / 1874C / 1874D / 2000M / 4322 / 4328)

13.130. CONNECTOR COMPOSITES (4087 / 4705 / 4706), P. 99G

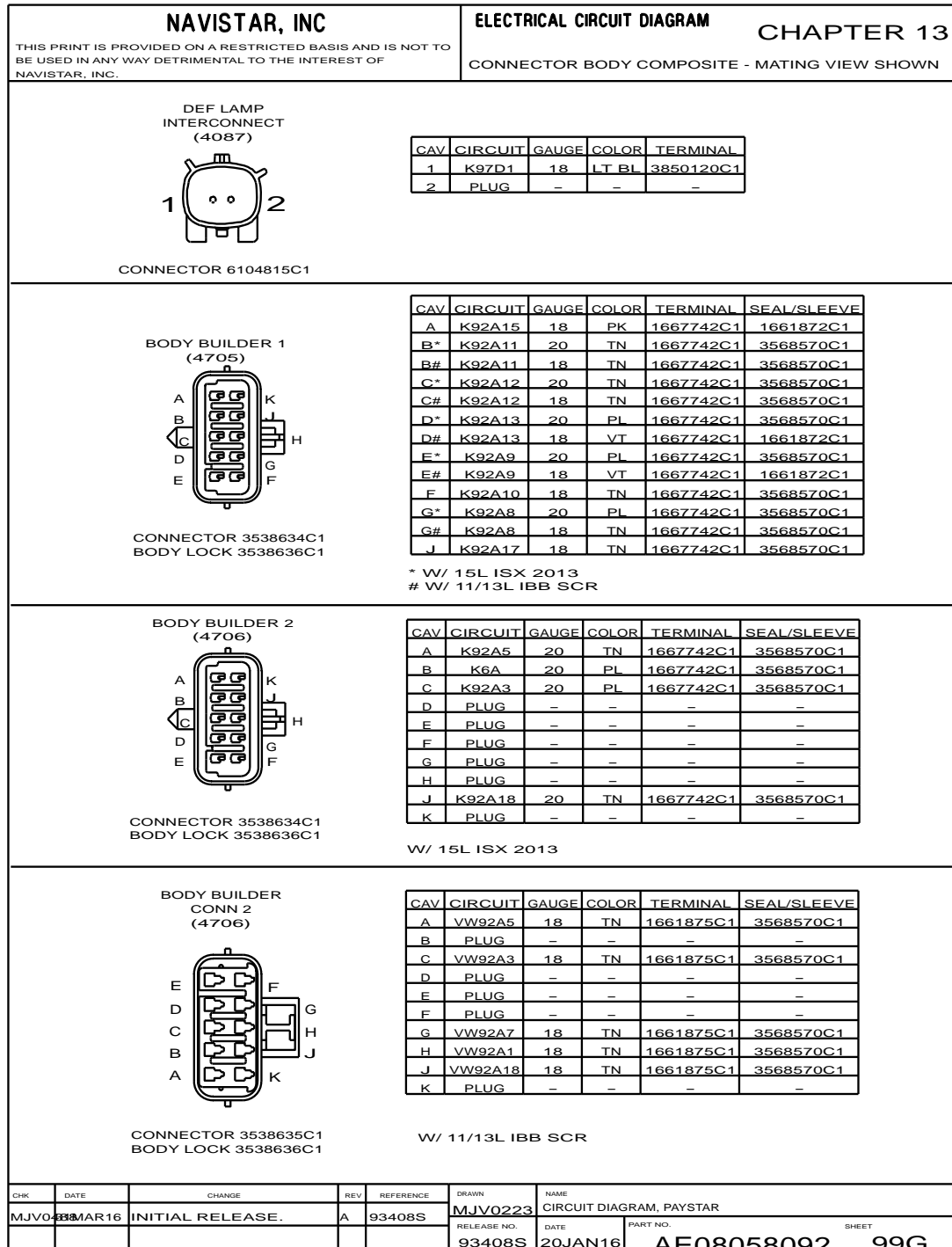


Figure 317 Connector Composites (4087 / 4705 / 4706)

13.131. CONNECTOR COMPOSITES (5501 / 5701L / 6000), P. 100

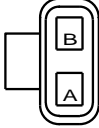

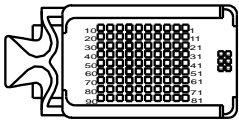
<p><b>NAVISTAR, INC</b></p> <p>THIS PRINT IS PROVIDED ON A RESTRICTED BASIS AND IS NOT TO BE USED IN ANY WAY DETRIMENTAL TO THE INTEREST OF NAVISTAR, INC.</p>	<p><b>ELECTRICAL CIRCUIT DIAGRAM</b></p> <p><b>CHAPTER 13</b></p>																																																																																																																																																																																																																																	
<p>AFTERTREATMENT FUSE (5501)</p>  <p>CONNECTOR 3512967C1</p>	<table border="1" style="width:100%; border-collapse: collapse;"> <thead> <tr> <th>CAV</th> <th>CIRCUIT</th> <th>GAUGE</th> <th>COLOR</th> <th>TERMINAL</th> </tr> </thead> <tbody> <tr> <td>A</td> <td>K14B</td> <td>10</td> <td>RD</td> <td>3679001C1</td> </tr> <tr> <td>B</td> <td>K14C</td> <td>10</td> <td>RD</td> <td>3679001C1</td> </tr> </tbody> </table>	CAV	CIRCUIT	GAUGE	COLOR	TERMINAL	A	K14B	10	RD	3679001C1	B	K14C	10	RD	3679001C1																																																																																																																																																																																																																		
CAV	CIRCUIT	GAUGE	COLOR	TERMINAL																																																																																																																																																																																																																														
A	K14B	10	RD	3679001C1																																																																																																																																																																																																																														
B	K14C	10	RD	3679001C1																																																																																																																																																																																																																														
<p>(5701L)</p>  <p>CONNECTOR 1661203C1</p>	<table border="1" style="width:100%; border-collapse: collapse;"> <thead> <tr> <th>CAV</th> <th>CIRCUIT</th> <th>GAUGE</th> <th>COLOR</th> <th>TERMINAL</th> </tr> </thead> <tbody> <tr> <td>A</td> <td>A14AN</td> <td>10</td> <td>RD</td> <td>1661627C1</td> </tr> </tbody> </table>	CAV	CIRCUIT	GAUGE	COLOR	TERMINAL	A	A14AN	10	RD	1661627C1																																																																																																																																																																																																																							
CAV	CIRCUIT	GAUGE	COLOR	TERMINAL																																																																																																																																																																																																																														
A	A14AN	10	RD	1661627C1																																																																																																																																																																																																																														
<p>ECM CONNECTOR (6000)</p>  <p>CONNECTOR 3945694C1 BODY LOCK 3743662C1</p>	<table border="1" style="width:100%; border-collapse: collapse;"> <thead> <tr> <th>CAV</th> <th>CIRCUIT</th> <th>GAUGE</th> <th>COLOR</th> <th>TERMINAL</th> </tr> </thead> <tbody> <tr><td>23</td><td>PLUG</td><td>-</td><td>-</td><td>-</td></tr> <tr><td>24</td><td>PLUG</td><td>-</td><td>-</td><td>-</td></tr> <tr><td>25</td><td>K14E</td><td>16</td><td>RD</td><td>3743666C1</td></tr> <tr><td>26</td><td>K14D</td><td>16</td><td>RD</td><td>3743666C1</td></tr> <tr><td>27</td><td>K14C</td><td>16</td><td>RD</td><td>3743666C1</td></tr> <tr><td>28</td><td>K14B</td><td>16</td><td>RD</td><td>3743666C1</td></tr> <tr><td>29</td><td>PLUG</td><td>-</td><td>-</td><td>-</td></tr> <tr><td>30</td><td>K92A8</td><td>20</td><td>TN</td><td>3743668C1</td></tr> <tr><td>30**</td><td>K92A8</td><td>20</td><td>PI</td><td>3743668C1</td></tr> <tr><td>31</td><td>PLUG</td><td>-</td><td>-</td><td>-</td></tr> <tr><td>32</td><td>K9A</td><td>20</td><td>TN</td><td>3743668C1</td></tr> <tr><td>33</td><td>K99-G</td><td>20</td><td>PL</td><td>3743668C1</td></tr> <tr><td>34</td><td>PLUG</td><td>-</td><td>-</td><td>-</td></tr> <tr><td>35</td><td>K34B</td><td>20</td><td>TN</td><td>3743668C1</td></tr> <tr><td>36</td><td>PLUG</td><td>-</td><td>-</td><td>-</td></tr> <tr><td>37</td><td>PLUG</td><td>-</td><td>-</td><td>-</td></tr> <tr><td>38</td><td>K95B</td><td>20</td><td>TN</td><td>3743668C1</td></tr> <tr><td>39</td><td>K95A1</td><td>20</td><td>TN</td><td>3743668C1</td></tr> <tr><td>40</td><td>K95C</td><td>20</td><td>TN</td><td>3743668C1</td></tr> <tr><td>41</td><td>K95</td><td>20</td><td>TN</td><td>3743668C1</td></tr> <tr><td>42</td><td>K95A</td><td>20</td><td>TN</td><td>3743668C1</td></tr> <tr><td>43@</td><td>K23AC</td><td>20</td><td>TN</td><td>3743668C1</td></tr> <tr><td>43&amp;@</td><td>K23AC</td><td>20</td><td>TN</td><td>3743668C1</td></tr> <tr><td>43</td><td>K23C</td><td>20</td><td>TN</td><td>3743668C1</td></tr> <tr><td>44</td><td>K97AL</td><td>20</td><td>PI</td><td>3743668C1</td></tr> <tr><td>45</td><td>PLUG</td><td>-</td><td>-</td><td>-</td></tr> <tr><td>46#</td><td>K98GN2</td><td>20</td><td>LT GN</td><td>3743668C1</td></tr> <tr><td>46&amp;#</td><td>K98GN2</td><td>20</td><td>LT GN</td><td>3743668C1</td></tr> <tr><td>46%&amp;</td><td>K5S(-)</td><td>20</td><td>LT GN</td><td>3743668C1</td></tr> <tr><td>46%&amp;</td><td>K5S(-)</td><td>20</td><td>LT GN</td><td>3743668C1</td></tr> <tr><td>47</td><td>PLUG</td><td>-</td><td>-</td><td>-</td></tr> <tr><td>48</td><td>K97ML</td><td>18</td><td>PI</td><td>3743666C1</td></tr> <tr><td>49</td><td>K10-GL</td><td>16</td><td>WH</td><td>3743666C1</td></tr> <tr><td>50</td><td>K10-GK</td><td>16</td><td>WH</td><td>3743666C1</td></tr> <tr><td>51</td><td>K10-GH</td><td>16</td><td>WH</td><td>3743666C1</td></tr> <tr><td>52</td><td>K10-GG</td><td>16</td><td>WH</td><td>3743666C1</td></tr> <tr><td>53</td><td>K95(-)</td><td>18</td><td>TN</td><td>3743666C1</td></tr> <tr><td>54</td><td>K95E</td><td>20</td><td>TN</td><td>3743668C1</td></tr> <tr><td>55</td><td>PLUG</td><td>-</td><td>-</td><td>-</td></tr> <tr><td>56</td><td>PLUG</td><td>-</td><td>-</td><td>-</td></tr> <tr><td>57</td><td>K95AA</td><td>20</td><td>TN</td><td>3743668C1</td></tr> <tr><td>58</td><td>PLUG</td><td>-</td><td>-</td><td>-</td></tr> <tr><td>59</td><td>K47AA</td><td>20</td><td>GY</td><td>3743668C1</td></tr> <tr><td>60</td><td>K47B</td><td>20</td><td>GY</td><td>3743668C1</td></tr> </tbody> </table>	CAV	CIRCUIT	GAUGE	COLOR	TERMINAL	23	PLUG	-	-	-	24	PLUG	-	-	-	25	K14E	16	RD	3743666C1	26	K14D	16	RD	3743666C1	27	K14C	16	RD	3743666C1	28	K14B	16	RD	3743666C1	29	PLUG	-	-	-	30	K92A8	20	TN	3743668C1	30**	K92A8	20	PI	3743668C1	31	PLUG	-	-	-	32	K9A	20	TN	3743668C1	33	K99-G	20	PL	3743668C1	34	PLUG	-	-	-	35	K34B	20	TN	3743668C1	36	PLUG	-	-	-	37	PLUG	-	-	-	38	K95B	20	TN	3743668C1	39	K95A1	20	TN	3743668C1	40	K95C	20	TN	3743668C1	41	K95	20	TN	3743668C1	42	K95A	20	TN	3743668C1	43@	K23AC	20	TN	3743668C1	43&@	K23AC	20	TN	3743668C1	43	K23C	20	TN	3743668C1	44	K97AL	20	PI	3743668C1	45	PLUG	-	-	-	46#	K98GN2	20	LT GN	3743668C1	46&#	K98GN2	20	LT GN	3743668C1	46%&	K5S(-)	20	LT GN	3743668C1	46%&	K5S(-)	20	LT GN	3743668C1	47	PLUG	-	-	-	48	K97ML	18	PI	3743666C1	49	K10-GL	16	WH	3743666C1	50	K10-GK	16	WH	3743666C1	51	K10-GH	16	WH	3743666C1	52	K10-GG	16	WH	3743666C1	53	K95(-)	18	TN	3743666C1	54	K95E	20	TN	3743668C1	55	PLUG	-	-	-	56	PLUG	-	-	-	57	K95AA	20	TN	3743668C1	58	PLUG	-	-	-	59	K47AA	20	GY	3743668C1	60	K47B	20	GY	3743668C1
CAV	CIRCUIT	GAUGE	COLOR	TERMINAL																																																																																																																																																																																																																														
23	PLUG	-	-	-																																																																																																																																																																																																																														
24	PLUG	-	-	-																																																																																																																																																																																																																														
25	K14E	16	RD	3743666C1																																																																																																																																																																																																																														
26	K14D	16	RD	3743666C1																																																																																																																																																																																																																														
27	K14C	16	RD	3743666C1																																																																																																																																																																																																																														
28	K14B	16	RD	3743666C1																																																																																																																																																																																																																														
29	PLUG	-	-	-																																																																																																																																																																																																																														
30	K92A8	20	TN	3743668C1																																																																																																																																																																																																																														
30**	K92A8	20	PI	3743668C1																																																																																																																																																																																																																														
31	PLUG	-	-	-																																																																																																																																																																																																																														
32	K9A	20	TN	3743668C1																																																																																																																																																																																																																														
33	K99-G	20	PL	3743668C1																																																																																																																																																																																																																														
34	PLUG	-	-	-																																																																																																																																																																																																																														
35	K34B	20	TN	3743668C1																																																																																																																																																																																																																														
36	PLUG	-	-	-																																																																																																																																																																																																																														
37	PLUG	-	-	-																																																																																																																																																																																																																														
38	K95B	20	TN	3743668C1																																																																																																																																																																																																																														
39	K95A1	20	TN	3743668C1																																																																																																																																																																																																																														
40	K95C	20	TN	3743668C1																																																																																																																																																																																																																														
41	K95	20	TN	3743668C1																																																																																																																																																																																																																														
42	K95A	20	TN	3743668C1																																																																																																																																																																																																																														
43@	K23AC	20	TN	3743668C1																																																																																																																																																																																																																														
43&@	K23AC	20	TN	3743668C1																																																																																																																																																																																																																														
43	K23C	20	TN	3743668C1																																																																																																																																																																																																																														
44	K97AL	20	PI	3743668C1																																																																																																																																																																																																																														
45	PLUG	-	-	-																																																																																																																																																																																																																														
46#	K98GN2	20	LT GN	3743668C1																																																																																																																																																																																																																														
46&#	K98GN2	20	LT GN	3743668C1																																																																																																																																																																																																																														
46%&	K5S(-)	20	LT GN	3743668C1																																																																																																																																																																																																																														
46%&	K5S(-)	20	LT GN	3743668C1																																																																																																																																																																																																																														
47	PLUG	-	-	-																																																																																																																																																																																																																														
48	K97ML	18	PI	3743666C1																																																																																																																																																																																																																														
49	K10-GL	16	WH	3743666C1																																																																																																																																																																																																																														
50	K10-GK	16	WH	3743666C1																																																																																																																																																																																																																														
51	K10-GH	16	WH	3743666C1																																																																																																																																																																																																																														
52	K10-GG	16	WH	3743666C1																																																																																																																																																																																																																														
53	K95(-)	18	TN	3743666C1																																																																																																																																																																																																																														
54	K95E	20	TN	3743668C1																																																																																																																																																																																																																														
55	PLUG	-	-	-																																																																																																																																																																																																																														
56	PLUG	-	-	-																																																																																																																																																																																																																														
57	K95AA	20	TN	3743668C1																																																																																																																																																																																																																														
58	PLUG	-	-	-																																																																																																																																																																																																																														
59	K47AA	20	GY	3743668C1																																																																																																																																																																																																																														
60	K47B	20	GY	3743668C1																																																																																																																																																																																																																														
<table border="1" style="width:100%; border-collapse: collapse;"> <thead> <tr> <th>CAV</th> <th>CIRCUIT</th> <th>GAUGE</th> <th>COLOR</th> <th>TERMINAL</th> </tr> </thead> <tbody> <tr><td>1</td><td>K14F</td><td>16</td><td>RD</td><td>3743666C1</td></tr> <tr><td>2</td><td>K95DEF</td><td>16</td><td>TN</td><td>3743666C1</td></tr> <tr><td>3</td><td>K95-GB</td><td>16</td><td>TN</td><td>3743666C1</td></tr> <tr><td>4</td><td>PLUG</td><td>-</td><td>-</td><td>-</td></tr> <tr><td>5</td><td>K13B</td><td>18</td><td>PK</td><td>3743666C1</td></tr> <tr><td>6</td><td>K95F</td><td>20</td><td>TN</td><td>3743668C1</td></tr> <tr><td>7</td><td>K95-GA</td><td>20</td><td>TN</td><td>3743668C1</td></tr> <tr><td>8*</td><td>K6A</td><td>20</td><td>PL</td><td>3743668C1</td></tr> <tr><td>8**</td><td>K6</td><td>20</td><td>PI</td><td>3743668C1</td></tr> <tr><td>9</td><td>K99A5V</td><td>20</td><td>PI</td><td>3743668C1</td></tr> <tr><td>10</td><td>K99</td><td>20</td><td>PI</td><td>3743668C1</td></tr> <tr><td>11</td><td>K23B</td><td>20</td><td>TN</td><td>3743668C1</td></tr> <tr><td>12</td><td>K97AB</td><td>20</td><td>PL</td><td>3743668C1</td></tr> <tr><td>12**</td><td>K92A21</td><td>20</td><td>PL</td><td>3743668C1</td></tr> <tr><td>13&amp;</td><td>K95</td><td>20</td><td>TN</td><td>3743668C1</td></tr> <tr><td>13@*</td><td>K95A</td><td>20</td><td>TN</td><td>3743668C1</td></tr> <tr><td>14</td><td>PLUG</td><td>-</td><td>-</td><td>-</td></tr> <tr><td>15</td><td>PLUG</td><td>-</td><td>-</td><td>-</td></tr> <tr><td>16</td><td>K95K</td><td>20</td><td>TN</td><td>3743668C1</td></tr> <tr><td>17</td><td>PLUG</td><td>-</td><td>-</td><td>-</td></tr> <tr><td>18</td><td>PLUG</td><td>-</td><td>-</td><td>-</td></tr> <tr><td>19</td><td>K97AA</td><td>20</td><td>PI</td><td>3743668C1</td></tr> <tr><td>19**</td><td>K92A23</td><td>20</td><td>PL</td><td>3743668C1</td></tr> <tr><td>20</td><td>K101</td><td>20</td><td>TN</td><td>3743668C1</td></tr> <tr><td>21</td><td>PLUG</td><td>-</td><td>-</td><td>-</td></tr> <tr><td>22#</td><td>K98YL2</td><td>20</td><td>YL</td><td>3743668C1</td></tr> <tr><td>22&amp;#</td><td>K98YL2</td><td>20</td><td>YL</td><td>3743668C1</td></tr> <tr><td>22%</td><td>K6S(+)</td><td>20</td><td>YL</td><td>3743668C1</td></tr> <tr><td>22%&amp;</td><td>K6S(+)</td><td>20</td><td>YL</td><td>3743668C1</td></tr> </tbody> </table> <p>* W/CRUISE CONTROL &amp; N/REMOTE PTO 5900          ** W/CRUISE CONTROL &amp; W/REMOTE PTO 5900          &amp; W/FUEL/WATER SEPARATOR-DAVCO,5900          &amp;# W/WALLISON 4000,4500,4700 RDS          % W/MANUAL TRANSMISSION          %&amp; W/ULTRASHIFT PLUS,W/PUSH BUTTON SHIFTER          @ W/AIR CONDITIONING &amp; N/FAN OVERRIDE &amp; W/APADS          &amp;@ W/AIR CONDITIONING &amp; W/FAN OVERRIDE &amp; W/APADS          @* W/FUEL/WATER SEPARATOR - RACOR, 5900</p>	CAV	CIRCUIT	GAUGE	COLOR	TERMINAL	1	K14F	16	RD	3743666C1	2	K95DEF	16	TN	3743666C1	3	K95-GB	16	TN	3743666C1	4	PLUG	-	-	-	5	K13B	18	PK	3743666C1	6	K95F	20	TN	3743668C1	7	K95-GA	20	TN	3743668C1	8*	K6A	20	PL	3743668C1	8**	K6	20	PI	3743668C1	9	K99A5V	20	PI	3743668C1	10	K99	20	PI	3743668C1	11	K23B	20	TN	3743668C1	12	K97AB	20	PL	3743668C1	12**	K92A21	20	PL	3743668C1	13&	K95	20	TN	3743668C1	13@*	K95A	20	TN	3743668C1	14	PLUG	-	-	-	15	PLUG	-	-	-	16	K95K	20	TN	3743668C1	17	PLUG	-	-	-	18	PLUG	-	-	-	19	K97AA	20	PI	3743668C1	19**	K92A23	20	PL	3743668C1	20	K101	20	TN	3743668C1	21	PLUG	-	-	-	22#	K98YL2	20	YL	3743668C1	22&#	K98YL2	20	YL	3743668C1	22%	K6S(+)	20	YL	3743668C1	22%&	K6S(+)	20	YL	3743668C1	<p style="text-align: right;">CONTINUED TO SHEET 101</p>																																																																											
CAV	CIRCUIT	GAUGE	COLOR	TERMINAL																																																																																																																																																																																																																														
1	K14F	16	RD	3743666C1																																																																																																																																																																																																																														
2	K95DEF	16	TN	3743666C1																																																																																																																																																																																																																														
3	K95-GB	16	TN	3743666C1																																																																																																																																																																																																																														
4	PLUG	-	-	-																																																																																																																																																																																																																														
5	K13B	18	PK	3743666C1																																																																																																																																																																																																																														
6	K95F	20	TN	3743668C1																																																																																																																																																																																																																														
7	K95-GA	20	TN	3743668C1																																																																																																																																																																																																																														
8*	K6A	20	PL	3743668C1																																																																																																																																																																																																																														
8**	K6	20	PI	3743668C1																																																																																																																																																																																																																														
9	K99A5V	20	PI	3743668C1																																																																																																																																																																																																																														
10	K99	20	PI	3743668C1																																																																																																																																																																																																																														
11	K23B	20	TN	3743668C1																																																																																																																																																																																																																														
12	K97AB	20	PL	3743668C1																																																																																																																																																																																																																														
12**	K92A21	20	PL	3743668C1																																																																																																																																																																																																																														
13&	K95	20	TN	3743668C1																																																																																																																																																																																																																														
13@*	K95A	20	TN	3743668C1																																																																																																																																																																																																																														
14	PLUG	-	-	-																																																																																																																																																																																																																														
15	PLUG	-	-	-																																																																																																																																																																																																																														
16	K95K	20	TN	3743668C1																																																																																																																																																																																																																														
17	PLUG	-	-	-																																																																																																																																																																																																																														
18	PLUG	-	-	-																																																																																																																																																																																																																														
19	K97AA	20	PI	3743668C1																																																																																																																																																																																																																														
19**	K92A23	20	PL	3743668C1																																																																																																																																																																																																																														
20	K101	20	TN	3743668C1																																																																																																																																																																																																																														
21	PLUG	-	-	-																																																																																																																																																																																																																														
22#	K98YL2	20	YL	3743668C1																																																																																																																																																																																																																														
22&#	K98YL2	20	YL	3743668C1																																																																																																																																																																																																																														
22%	K6S(+)	20	YL	3743668C1																																																																																																																																																																																																																														
22%&	K6S(+)	20	YL	3743668C1																																																																																																																																																																																																																														
<table border="1" style="width:100%; border-collapse: collapse;"> <thead> <tr> <th>CHK</th> <th>DATE</th> <th>CHANGE</th> <th>REV</th> <th>REFERENCE</th> <th>DRAWN</th> <th>NAME</th> </tr> </thead> <tbody> <tr> <td>0488</td> <td>09SEP15</td> <td>ADDED R/D 5701L.</td> <td>D</td> <td>93248U</td> <td>300371</td> <td>CIRCUIT DIAGRAM, PAYSTAR</td> </tr> <tr> <td></td> <td></td> <td></td> <td></td> <td></td> <td>RELEASE NO.</td> <td>DATE</td> </tr> <tr> <td></td> <td></td> <td></td> <td></td> <td></td> <td>61879Y</td> <td>17SEP09</td> </tr> <tr> <td></td> <td></td> <td></td> <td></td> <td></td> <td>PART NO.</td> <td>SHEET</td> </tr> <tr> <td></td> <td></td> <td></td> <td></td> <td></td> <td>AE08058092</td> <td>100</td> </tr> </tbody> </table>	CHK	DATE	CHANGE	REV	REFERENCE	DRAWN	NAME	0488	09SEP15	ADDED R/D 5701L.	D	93248U	300371	CIRCUIT DIAGRAM, PAYSTAR						RELEASE NO.	DATE						61879Y	17SEP09						PART NO.	SHEET						AE08058092	100																																																																																																																																																																																								
CHK	DATE	CHANGE	REV	REFERENCE	DRAWN	NAME																																																																																																																																																																																																																												
0488	09SEP15	ADDED R/D 5701L.	D	93248U	300371	CIRCUIT DIAGRAM, PAYSTAR																																																																																																																																																																																																																												
					RELEASE NO.	DATE																																																																																																																																																																																																																												
					61879Y	17SEP09																																																																																																																																																																																																																												
					PART NO.	SHEET																																																																																																																																																																																																																												
					AE08058092	100																																																																																																																																																																																																																												

Figure 318 Connector Composites (5501 / 5701L / 6000)



13.132. CONNECTOR COMPOSITES (6000 / 6001), P. 101

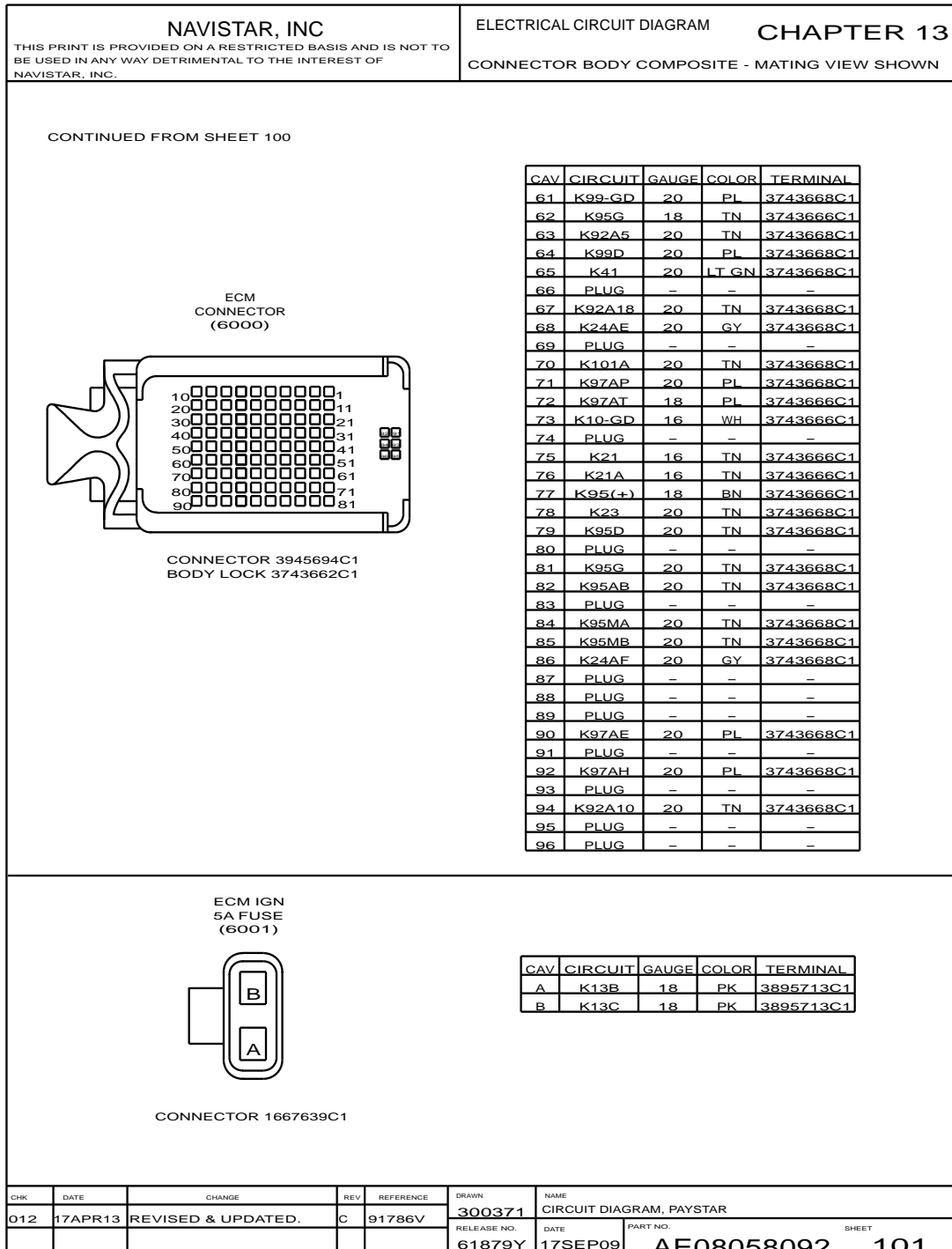


Figure 319 Connector Composites (6000 / 6001)

13.133. CONNECTOR COMPOSITES (6018), P. 102

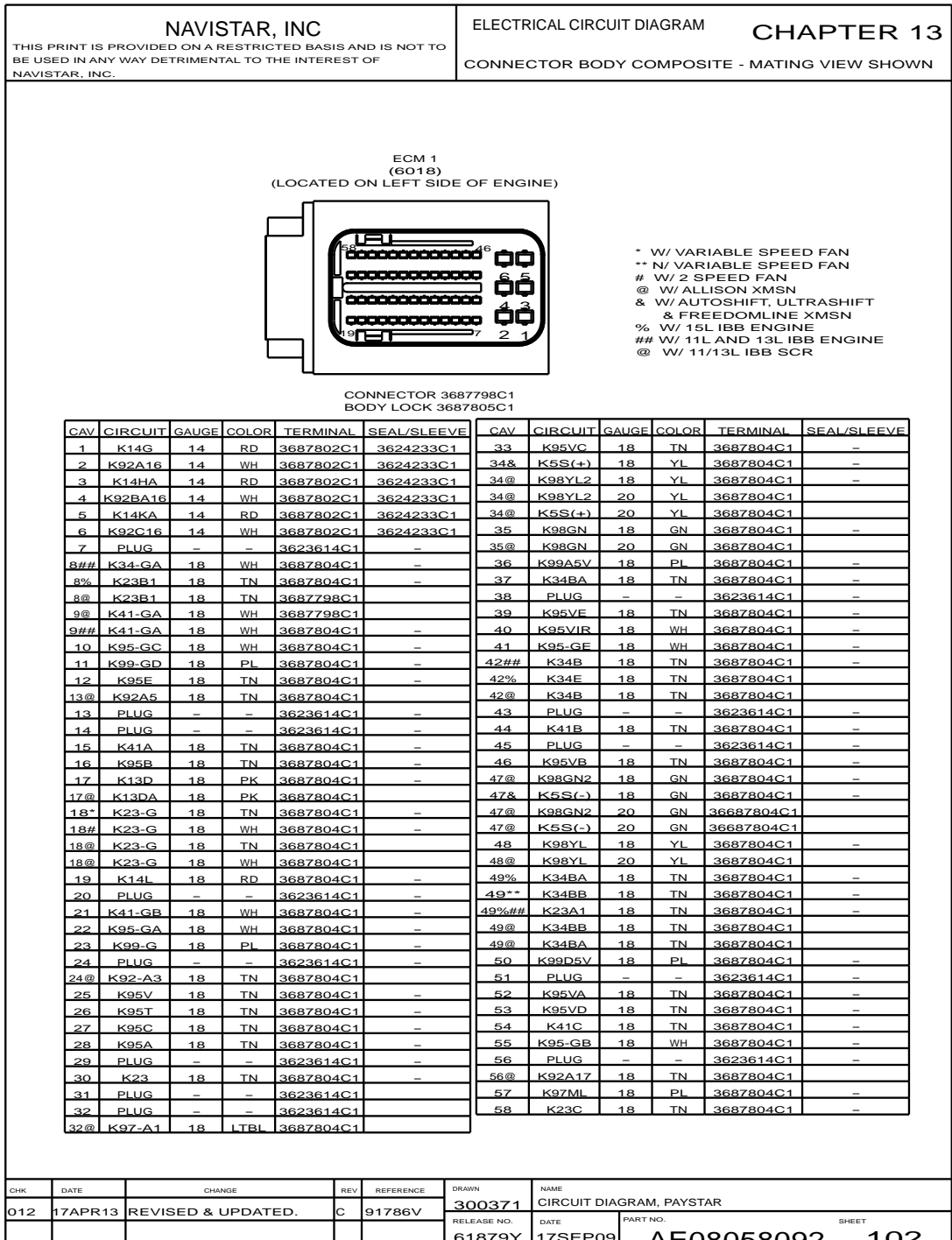


Figure 320 Connector Composites (6018)

13.134. CONNECTOR COMPOSITES (6019), P. 103

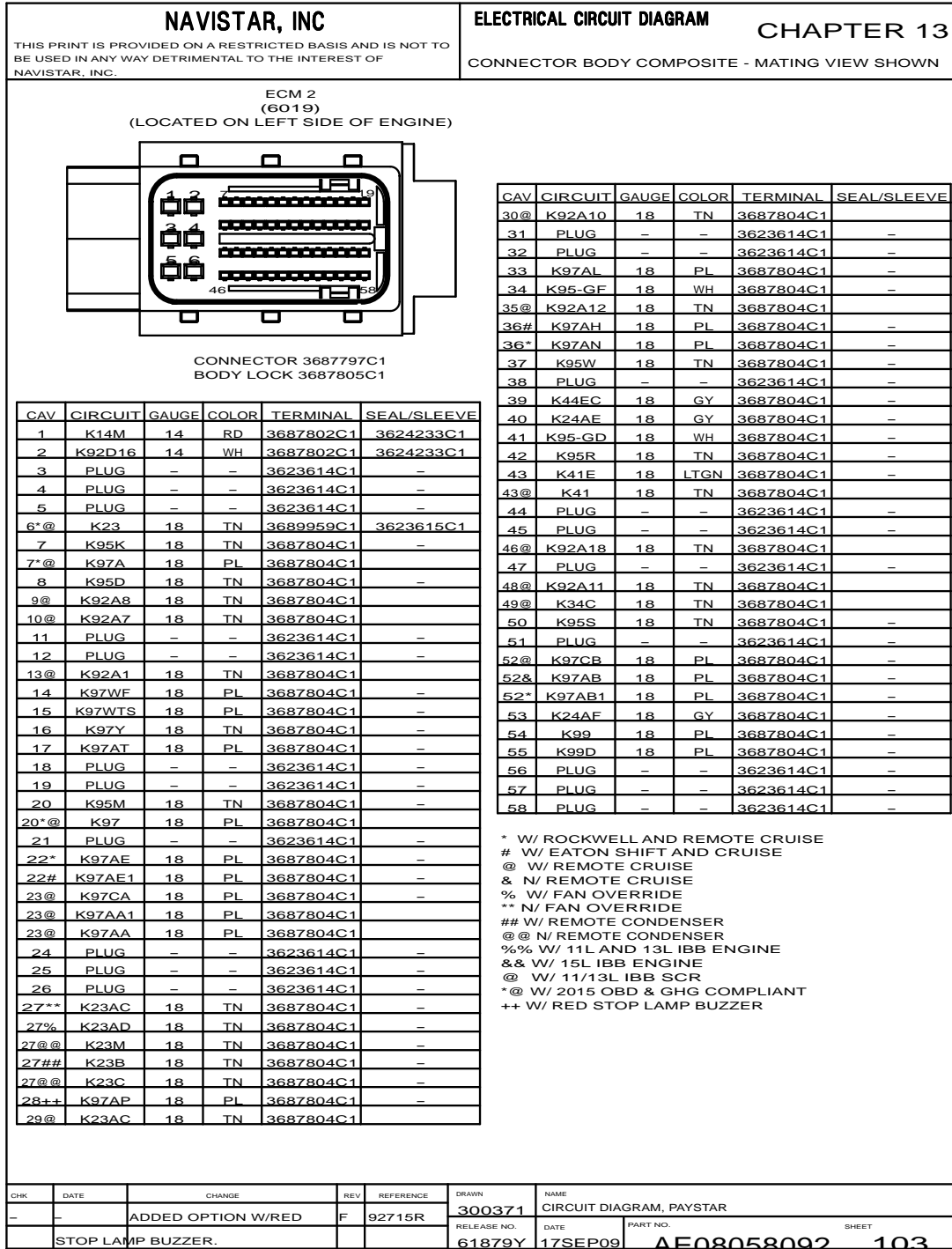


Figure 321 Connector Composites (6019)

13.135. CONNECTOR COMPOSITES (6033 / 6200 / 6195), P. 104

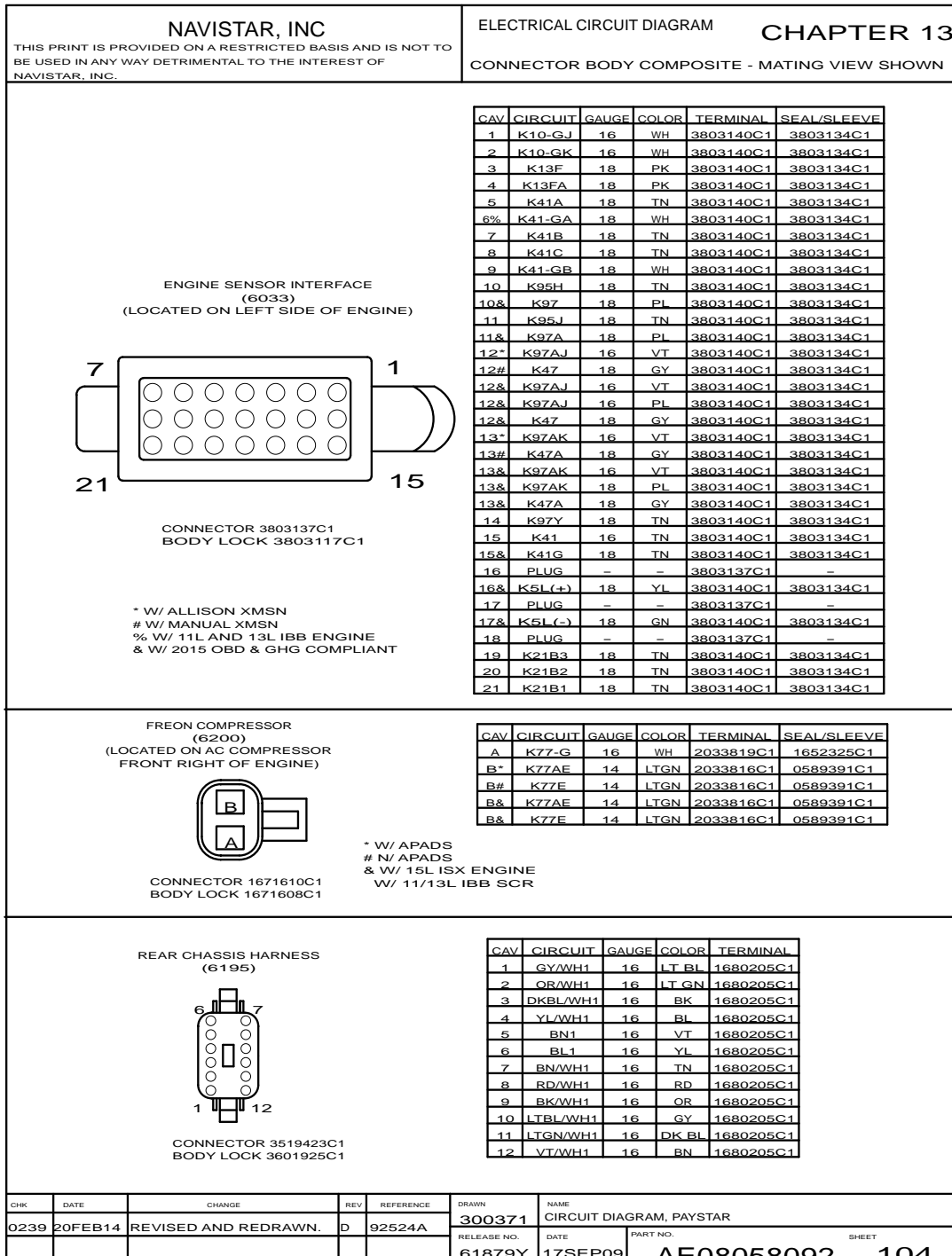


Figure 322 Connector Composites (6033 / 6200 / 6195)

13.136. CONNECTOR COMPOSITES (6260VH / 6260VL / 6260VM / 6260VN / 6401 / 6300), P. 105



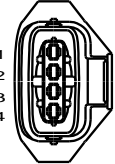

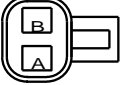

<b>NAVISTAR, INC</b> <small>THIS PRINT IS PROVIDED ON A RESTRICTED BASIS AND IS NOT TO BE USED IN ANY WAY DETRIMENTAL TO THE INTEREST OF NAVISTAR, INC.</small>				ELECTRICAL CIRCUIT DIAGRAM <b>CHAPTER 13</b> CONNECTOR BODY COMPOSITE - MATING VIEW SHOWN																																												
<b>HCI INJECTOR DOSING VALVE</b> (6260VH) (LOCATED ON LEFT SIDE OF ENGINE)																																																
		<table border="1" style="width:100%; border-collapse: collapse;"> <thead> <tr> <th>CAV</th> <th>CIRCUIT</th> <th>GAUGE</th> <th>COLOR</th> <th>TERMINAL</th> <th>SEAL/SLEEVE</th> </tr> </thead> <tbody> <tr> <td>1</td> <td>K95H</td> <td>18</td> <td>TN</td> <td>3689960C1</td> <td>3623615C1</td> </tr> <tr> <td>2</td> <td>K95J</td> <td>18</td> <td>TN</td> <td>3689960C1</td> <td>3623615C1</td> </tr> </tbody> </table>					CAV	CIRCUIT	GAUGE	COLOR	TERMINAL	SEAL/SLEEVE	1	K95H	18	TN	3689960C1	3623615C1	2	K95J	18	TN	3689960C1	3623615C1																								
CAV	CIRCUIT	GAUGE	COLOR	TERMINAL	SEAL/SLEEVE																																											
1	K95H	18	TN	3689960C1	3623615C1																																											
2	K95J	18	TN	3689960C1	3623615C1																																											
CONNECTOR 3690364C1																																																
<b>HCI FUEL SHUT OFF VALVE</b> (6260VL) (LOCATED ON LEFT SIDE OF ENGINE)																																																
		<table border="1" style="width:100%; border-collapse: collapse;"> <thead> <tr> <th>CAV</th> <th>CIRCUIT</th> <th>GAUGE</th> <th>COLOR</th> <th>TERMINAL</th> <th>SEAL/SLEEVE</th> </tr> </thead> <tbody> <tr> <td>1</td> <td>K95K</td> <td>18</td> <td>TN</td> <td>3689960C1</td> <td>3623615C1</td> </tr> <tr> <td>2</td> <td>K95M</td> <td>18</td> <td>TN</td> <td>3689960C1</td> <td>3623615C1</td> </tr> </tbody> </table>					CAV	CIRCUIT	GAUGE	COLOR	TERMINAL	SEAL/SLEEVE	1	K95K	18	TN	3689960C1	3623615C1	2	K95M	18	TN	3689960C1	3623615C1																								
CAV	CIRCUIT	GAUGE	COLOR	TERMINAL	SEAL/SLEEVE																																											
1	K95K	18	TN	3689960C1	3623615C1																																											
2	K95M	18	TN	3689960C1	3623615C1																																											
CONNECTOR 3689957C1																																																
<b>AFTERTREATMENT FUEL TEMP &amp; PRESSURE</b> (6260VM) (LOCATED ON LEFT SIDE OF ENGINE)																																																
		<table border="1" style="width:100%; border-collapse: collapse;"> <thead> <tr> <th>CAV</th> <th>CIRCUIT</th> <th>GAUGE</th> <th>COLOR</th> <th>TERMINAL</th> <th>SEAL/SLEEVE</th> </tr> </thead> <tbody> <tr> <td>1</td> <td>K95-GE</td> <td>18</td> <td>WH</td> <td>3689959C1</td> <td>3623615C1</td> </tr> <tr> <td>2</td> <td>K95T</td> <td>18</td> <td>TN</td> <td>3689959C1</td> <td>3623615C1</td> </tr> <tr> <td>3</td> <td>K95DC</td> <td>18</td> <td>TN</td> <td>3689959C1</td> <td>3623615C1</td> </tr> <tr> <td>4</td> <td>K95V</td> <td>18</td> <td>TN</td> <td>3689959C1</td> <td>3623615C1</td> </tr> </tbody> </table>					CAV	CIRCUIT	GAUGE	COLOR	TERMINAL	SEAL/SLEEVE	1	K95-GE	18	WH	3689959C1	3623615C1	2	K95T	18	TN	3689959C1	3623615C1	3	K95DC	18	TN	3689959C1	3623615C1	4	K95V	18	TN	3689959C1	3623615C1												
CAV	CIRCUIT	GAUGE	COLOR	TERMINAL	SEAL/SLEEVE																																											
1	K95-GE	18	WH	3689959C1	3623615C1																																											
2	K95T	18	TN	3689959C1	3623615C1																																											
3	K95DC	18	TN	3689959C1	3623615C1																																											
4	K95V	18	TN	3689959C1	3623615C1																																											
CONNECTOR 3689956C1																																																
<b>EXHAUST LAMBDA SENSOR</b> (6260VN) (LOCATED ON LEFT SIDE OF ENGINE)																																																
		<table border="1" style="width:100%; border-collapse: collapse;"> <thead> <tr> <th>CAV</th> <th>CIRCUIT</th> <th>GAUGE</th> <th>COLOR</th> <th>TERMINAL</th> <th>SEAL/SLEEVE</th> </tr> </thead> <tbody> <tr> <td>1</td> <td>K95VA</td> <td>18</td> <td>TN</td> <td>3693147C1</td> <td>3573653C1</td> </tr> <tr> <td>2</td> <td>K95VJR</td> <td>18</td> <td>WH</td> <td>3693147C1</td> <td>3573653C1</td> </tr> <tr> <td>3</td> <td>K95VB</td> <td>18</td> <td>TN</td> <td>3693147C1</td> <td>3573653C1</td> </tr> <tr> <td>4</td> <td>K95VC</td> <td>18</td> <td>TN</td> <td>3693147C1</td> <td>3573653C1</td> </tr> <tr> <td>5</td> <td>K95VD</td> <td>18</td> <td>TN</td> <td>3693147C1</td> <td>3573653C1</td> </tr> <tr> <td>6</td> <td>K95VE</td> <td>18</td> <td>TN</td> <td>3693147C1</td> <td>3573653C1</td> </tr> </tbody> </table>					CAV	CIRCUIT	GAUGE	COLOR	TERMINAL	SEAL/SLEEVE	1	K95VA	18	TN	3693147C1	3573653C1	2	K95VJR	18	WH	3693147C1	3573653C1	3	K95VB	18	TN	3693147C1	3573653C1	4	K95VC	18	TN	3693147C1	3573653C1	5	K95VD	18	TN	3693147C1	3573653C1	6	K95VE	18	TN	3693147C1	3573653C1
CAV	CIRCUIT	GAUGE	COLOR	TERMINAL	SEAL/SLEEVE																																											
1	K95VA	18	TN	3693147C1	3573653C1																																											
2	K95VJR	18	WH	3693147C1	3573653C1																																											
3	K95VB	18	TN	3693147C1	3573653C1																																											
4	K95VC	18	TN	3693147C1	3573653C1																																											
5	K95VD	18	TN	3693147C1	3573653C1																																											
6	K95VE	18	TN	3693147C1	3573653C1																																											
CONNECTOR 3691136C1																																																
<b>COOLANT LEVEL SENSOR</b> (6401)																																																
		<table border="1" style="width:100%; border-collapse: collapse;"> <thead> <tr> <th>CAV</th> <th>CIRCUIT</th> <th>GAUGE</th> <th>COLOR</th> <th>TERMINAL</th> <th>SEAL/SLEEVE</th> </tr> </thead> <tbody> <tr> <td>A</td> <td>K34E</td> <td>18</td> <td>TN</td> <td>2033819C1</td> <td>3517771C1</td> </tr> <tr> <td>B</td> <td>K34F</td> <td>18</td> <td>TN</td> <td>2033819C1</td> <td>3517771C1</td> </tr> </tbody> </table>					CAV	CIRCUIT	GAUGE	COLOR	TERMINAL	SEAL/SLEEVE	A	K34E	18	TN	2033819C1	3517771C1	B	K34F	18	TN	2033819C1	3517771C1																								
CAV	CIRCUIT	GAUGE	COLOR	TERMINAL	SEAL/SLEEVE																																											
A	K34E	18	TN	2033819C1	3517771C1																																											
B	K34F	18	TN	2033819C1	3517771C1																																											
CONNECTOR 1671610C1																																																
<b>VARIABLE SPEED FAN</b> (6300) (LOCATED ON FRONT OF RADIATOR)																																																
		<table border="1" style="width:100%; border-collapse: collapse;"> <thead> <tr> <th>CAV</th> <th>CIRCUIT</th> <th>GAUGE</th> <th>COLOR</th> <th>TERMINAL</th> </tr> </thead> <tbody> <tr> <td>1</td> <td>K23-G</td> <td>18</td> <td>TN</td> <td>355249C1</td> </tr> <tr> <td>2</td> <td>K23A1</td> <td>18</td> <td>TN</td> <td>355249C1</td> </tr> <tr> <td>3</td> <td>K23</td> <td>18</td> <td>TN</td> <td>355249C1</td> </tr> <tr> <td>4</td> <td>K23B1</td> <td>18</td> <td>TN</td> <td>355249C1</td> </tr> <tr> <td>5</td> <td>K23C</td> <td>18</td> <td>TN</td> <td>355249C1</td> </tr> <tr> <td>6</td> <td>PLUG</td> <td>-</td> <td>-</td> <td>3527276C1</td> </tr> </tbody> </table>					CAV	CIRCUIT	GAUGE	COLOR	TERMINAL	1	K23-G	18	TN	355249C1	2	K23A1	18	TN	355249C1	3	K23	18	TN	355249C1	4	K23B1	18	TN	355249C1	5	K23C	18	TN	355249C1	6	PLUG	-	-	3527276C1							
CAV	CIRCUIT	GAUGE	COLOR	TERMINAL																																												
1	K23-G	18	TN	355249C1																																												
2	K23A1	18	TN	355249C1																																												
3	K23	18	TN	355249C1																																												
4	K23B1	18	TN	355249C1																																												
5	K23C	18	TN	355249C1																																												
6	PLUG	-	-	3527276C1																																												
CONNECTOR 3579124C1 BODY LOCK 3579126C1																																																
W/ 15L IBB ENGINE																																																
CHK	DATE	CHANGE	REV	REFERENCE	DRAWN	NAME																																										
012	17APR13	REVISED & UPDATED.	C	91786V	300371	CIRCUIT DIAGRAM, PAYSTAR																																										
				RELEASE NO.	DATE	PART NO.																																										
				61879Y	17SEP09	AE08058092																																										
						SHEET 105																																										

Figure 323 Connector Composites (6260VH / 6260VL / 6260VM / 6260VN / 6401 / 6300)

13.137. CONNECTOR COMPOSITES (6420 / 6703 / 6704B / 6704D), P. 106

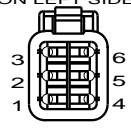
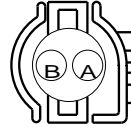
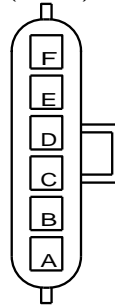
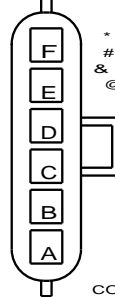
<b>NAVISTAR, INC</b> <small>THIS PRINT IS PROVIDED ON A RESTRICTED BASIS AND IS NOT TO BE USED IN ANY WAY DETRIMENTAL TO THE INTEREST OF NAVISTAR, INC.</small>				ELECTRICAL CIRCUIT DIAGRAM <b>CHAPTER 13</b> CONNECTOR BODY COMPOSITE - MATING VIEW SHOWN																																																																																					
VARIABLE SPEED FAN (6420) (LOCATED ON LEFT SIDE OF ENGINE)  CONNECTOR 3579124C1 BODY LOCK 3579126C1		<table border="1" style="width:100%; border-collapse: collapse;"> <thead> <tr> <th>CAV</th> <th>CIRCUIT</th> <th>GAUGE</th> <th>COLOR</th> <th>TERMINAL</th> </tr> </thead> <tbody> <tr><td>1</td><td>K23-G</td><td>18</td><td>TN</td><td>3518963C1</td></tr> <tr><td>2</td><td>K23A1</td><td>18</td><td>TN</td><td>3518963C1</td></tr> <tr><td>3</td><td>K23</td><td>18</td><td>TN</td><td>3518963C1</td></tr> <tr><td>4</td><td>K23B1</td><td>18</td><td>TN</td><td>3518963C1</td></tr> <tr><td>5</td><td>K23C</td><td>18</td><td>TN</td><td>3518963C1</td></tr> <tr><td>6</td><td>PLUG</td><td>-</td><td>-</td><td>3527276C1</td></tr> </tbody> </table>				CAV	CIRCUIT	GAUGE	COLOR	TERMINAL	1	K23-G	18	TN	3518963C1	2	K23A1	18	TN	3518963C1	3	K23	18	TN	3518963C1	4	K23B1	18	TN	3518963C1	5	K23C	18	TN	3518963C1	6	PLUG	-	-	3527276C1																																																	
CAV	CIRCUIT	GAUGE	COLOR	TERMINAL																																																																																					
1	K23-G	18	TN	3518963C1																																																																																					
2	K23A1	18	TN	3518963C1																																																																																					
3	K23	18	TN	3518963C1																																																																																					
4	K23B1	18	TN	3518963C1																																																																																					
5	K23C	18	TN	3518963C1																																																																																					
6	PLUG	-	-	3527276C1																																																																																					
INTAKE AIR TEMPERATURE SENSOR (6703) (LOCATED ON AIR FILTER HOUSING)  CONNECTOR 1689462C1 BODY LOCK 1689463C1		<table border="1" style="width:100%; border-collapse: collapse;"> <thead> <tr> <th>CAV</th> <th>CIRCUIT</th> <th>GAUGE</th> <th>COLOR</th> <th>TERMINAL</th> </tr> </thead> <tbody> <tr><td>A</td><td>K41</td><td>16</td><td>TN</td><td>1689464C1</td></tr> <tr><td>B</td><td>K41-GC</td><td>16</td><td>WH</td><td>1689464C1</td></tr> </tbody> </table>				CAV	CIRCUIT	GAUGE	COLOR	TERMINAL	A	K41	16	TN	1689464C1	B	K41-GC	16	WH	1689464C1																																																																					
CAV	CIRCUIT	GAUGE	COLOR	TERMINAL																																																																																					
A	K41	16	TN	1689464C1																																																																																					
B	K41-GC	16	WH	1689464C1																																																																																					
GROUND ADAPTER (6704B)  CONNECTOR 3551896C1 BODY LOCK 3551897C1		W/ 11L AND 13L IBB ENGINE <table border="1" style="width:100%; border-collapse: collapse;"> <thead> <tr> <th>CAV</th> <th>CIRCUIT</th> <th>GAUGE</th> <th>COLOR</th> <th>TERMINAL</th> <th>SEAL/SLEEVE</th> </tr> </thead> <tbody> <tr><td>A</td><td>K10-GB</td><td>10</td><td>WH</td><td>1687847C1</td><td>0589390C1</td></tr> <tr><td>B*</td><td>K31-G</td><td>16</td><td>WH</td><td>2033819C1</td><td>1652325C1</td></tr> <tr><td>B#</td><td>K31-G</td><td>16</td><td>TN</td><td>2033819C1</td><td>1652325C1</td></tr> <tr><td>B&amp;</td><td>K31-G</td><td>16</td><td>WH</td><td>2033819C2</td><td>1652325C2</td></tr> <tr><td>B&amp;</td><td>K31-G</td><td>16</td><td>TN</td><td>2033819C3</td><td>1652325C3</td></tr> <tr><td>C</td><td>K77-G</td><td>16</td><td>WH</td><td>2033819C1</td><td>1652325C1</td></tr> <tr><td>D</td><td>PLUG</td><td>-</td><td>-</td><td>0587579C1</td><td>-</td></tr> <tr><td>E</td><td>K30-GB</td><td>16</td><td>TN</td><td>2033819C1</td><td>1652325C1</td></tr> <tr><td>F</td><td>K97-GC</td><td>18</td><td>VT</td><td>2033819C1</td><td>1652325C1</td></tr> </tbody> </table> <p style="text-align: center;">* W/ ALLISON XMSN # N/ ALLISON XMSN &amp; W/ 11/13L IBB SCR</p>				CAV	CIRCUIT	GAUGE	COLOR	TERMINAL	SEAL/SLEEVE	A	K10-GB	10	WH	1687847C1	0589390C1	B*	K31-G	16	WH	2033819C1	1652325C1	B#	K31-G	16	TN	2033819C1	1652325C1	B&	K31-G	16	WH	2033819C2	1652325C2	B&	K31-G	16	TN	2033819C3	1652325C3	C	K77-G	16	WH	2033819C1	1652325C1	D	PLUG	-	-	0587579C1	-	E	K30-GB	16	TN	2033819C1	1652325C1	F	K97-GC	18	VT	2033819C1	1652325C1																								
CAV	CIRCUIT	GAUGE	COLOR	TERMINAL	SEAL/SLEEVE																																																																																				
A	K10-GB	10	WH	1687847C1	0589390C1																																																																																				
B*	K31-G	16	WH	2033819C1	1652325C1																																																																																				
B#	K31-G	16	TN	2033819C1	1652325C1																																																																																				
B&	K31-G	16	WH	2033819C2	1652325C2																																																																																				
B&	K31-G	16	TN	2033819C3	1652325C3																																																																																				
C	K77-G	16	WH	2033819C1	1652325C1																																																																																				
D	PLUG	-	-	0587579C1	-																																																																																				
E	K30-GB	16	TN	2033819C1	1652325C1																																																																																				
F	K97-GC	18	VT	2033819C1	1652325C1																																																																																				
GROUND ADAPTER (6704D)  CONNECTOR 3551896C1 BODY LOCK 3551897C1		W/ 15L IBB ENGINE <table border="1" style="width:100%; border-collapse: collapse;"> <thead> <tr> <th>CAV</th> <th>CIRCUIT</th> <th>GAUGE</th> <th>COLOR</th> <th>TERMINAL</th> <th>SEAL/SLEEVE</th> </tr> </thead> <tbody> <tr><td>A</td><td>K10-GB</td><td>10</td><td>WH</td><td>1687847C1</td><td>0589390C1</td></tr> <tr><td>A&amp;</td><td>K13DA</td><td>18</td><td>PK</td><td>2033819C1</td><td>3517771C1</td></tr> <tr><td>B*</td><td>K31-G</td><td>16</td><td>WH</td><td>2033819C1</td><td>1652325C1</td></tr> <tr><td>B#</td><td>K31-G</td><td>16</td><td>TN</td><td>2033819C1</td><td>1652325C1</td></tr> <tr><td>B@</td><td>K31-G</td><td>16</td><td>WH</td><td>2033819C1</td><td>1652325C1</td></tr> <tr><td>B&amp;</td><td>K13D</td><td>18</td><td>PK</td><td>2033819C1</td><td>3517771C1</td></tr> <tr><td>C</td><td>K77-G</td><td>16</td><td>WH</td><td>2033819C1</td><td>1652325C1</td></tr> <tr><td>C&amp;</td><td>K95-PG</td><td>18</td><td>RD</td><td>2033819C1</td><td>3517771C1</td></tr> <tr><td>D</td><td>PLUG</td><td>-</td><td>-</td><td>0587579C1</td><td>-</td></tr> <tr><td>D@</td><td>K31-G</td><td>18</td><td>GY</td><td>2033819C1</td><td>1652325C1</td></tr> <tr><td>E</td><td>K30-GB</td><td>16</td><td>TN</td><td>2033819C1</td><td>1652325C1</td></tr> <tr><td>E@</td><td>K30-GB</td><td>18</td><td>TN</td><td>2033819C1</td><td>3517771C1</td></tr> <tr><td>F</td><td>PLUG</td><td>-</td><td>-</td><td>0587579C1</td><td>-</td></tr> </tbody> </table> <p style="text-align: center;">* W/ ALLISON XMSN # N/ ALLISON XMSN &amp; W/ 11/13L IBB SCR @ W/ 15L ISX 2013</p>				CAV	CIRCUIT	GAUGE	COLOR	TERMINAL	SEAL/SLEEVE	A	K10-GB	10	WH	1687847C1	0589390C1	A&	K13DA	18	PK	2033819C1	3517771C1	B*	K31-G	16	WH	2033819C1	1652325C1	B#	K31-G	16	TN	2033819C1	1652325C1	B@	K31-G	16	WH	2033819C1	1652325C1	B&	K13D	18	PK	2033819C1	3517771C1	C	K77-G	16	WH	2033819C1	1652325C1	C&	K95-PG	18	RD	2033819C1	3517771C1	D	PLUG	-	-	0587579C1	-	D@	K31-G	18	GY	2033819C1	1652325C1	E	K30-GB	16	TN	2033819C1	1652325C1	E@	K30-GB	18	TN	2033819C1	3517771C1	F	PLUG	-	-	0587579C1	-
CAV	CIRCUIT	GAUGE	COLOR	TERMINAL	SEAL/SLEEVE																																																																																				
A	K10-GB	10	WH	1687847C1	0589390C1																																																																																				
A&	K13DA	18	PK	2033819C1	3517771C1																																																																																				
B*	K31-G	16	WH	2033819C1	1652325C1																																																																																				
B#	K31-G	16	TN	2033819C1	1652325C1																																																																																				
B@	K31-G	16	WH	2033819C1	1652325C1																																																																																				
B&	K13D	18	PK	2033819C1	3517771C1																																																																																				
C	K77-G	16	WH	2033819C1	1652325C1																																																																																				
C&	K95-PG	18	RD	2033819C1	3517771C1																																																																																				
D	PLUG	-	-	0587579C1	-																																																																																				
D@	K31-G	18	GY	2033819C1	1652325C1																																																																																				
E	K30-GB	16	TN	2033819C1	1652325C1																																																																																				
E@	K30-GB	18	TN	2033819C1	3517771C1																																																																																				
F	PLUG	-	-	0587579C1	-																																																																																				
CHK	DATE	CHANGE	REV	REFERENCE	DRAWN	NAME																																																																																			
012	17APR13	REVISED & UPDATED.	C	91786V	300371	CIRCUIT DIAGRAM, PAYSTAR																																																																																			
					RELEASE NO.	DATE																																																																																			
					61879Y	17SEP09																																																																																			
					PART NO.	SHEET																																																																																			
					AE08058092	106																																																																																			

Figure 324 Connector Composites (6420 / 6703 / 6704B / 6704D)

13.138. CONNECTOR COMPOSITES (6705B / 6715), P. 107

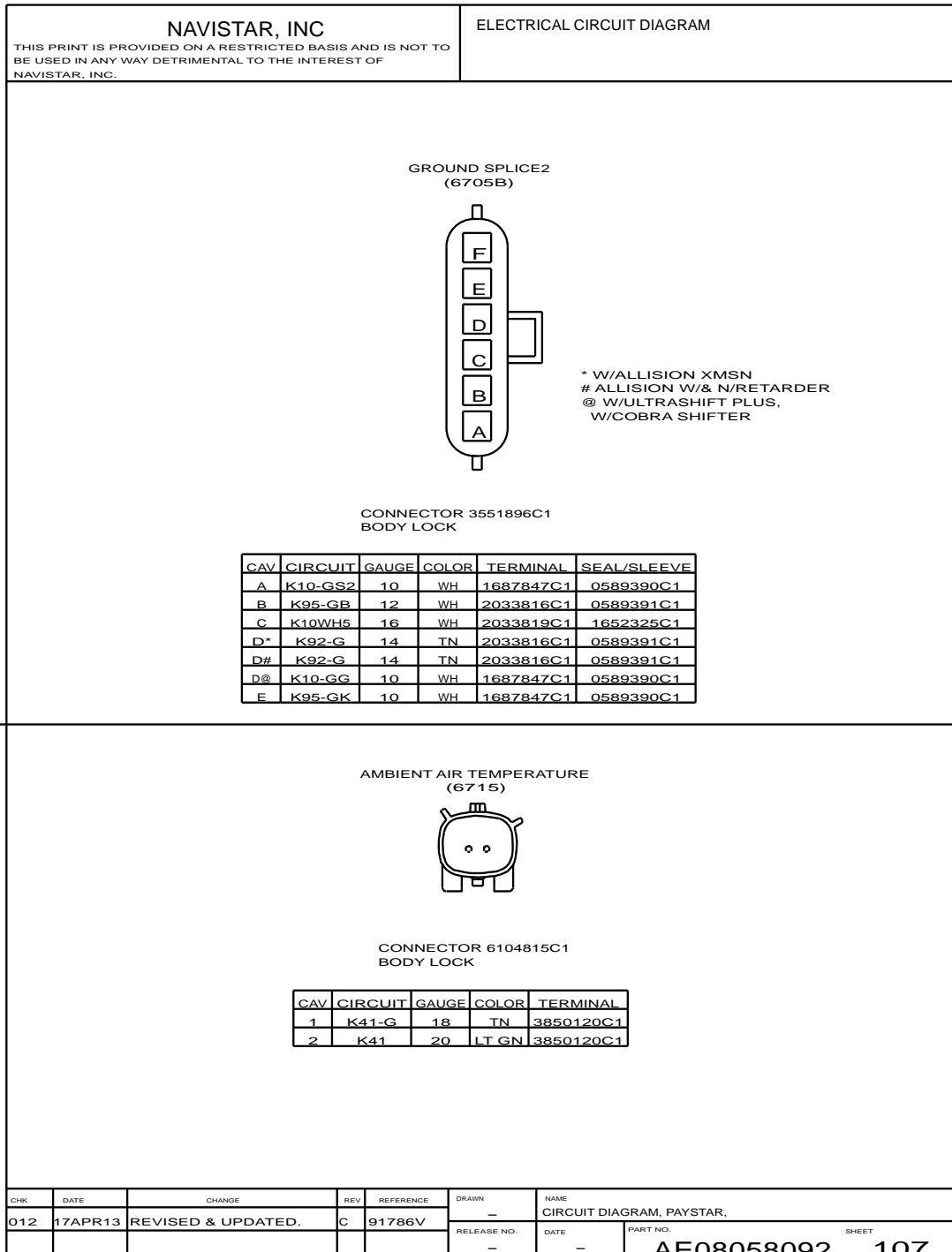


Figure 325 Connector Composites (6705B / 6715)

13.139. CONNECTOR COMPOSITES (6720 / 6720A), P. 108

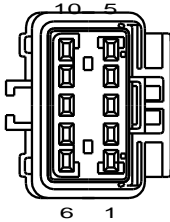
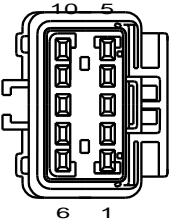
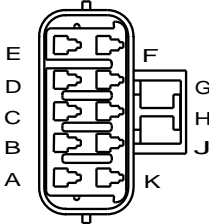
<b>NAVISTAR, INC</b> <small>THIS PRINT IS PROVIDED ON A RESTRICTED BASIS AND IS NOT TO BE USED IN ANY WAY DETRIMENTAL TO THE INTEREST OF NAVISTAR, INC.</small>				ELECTRICAL CIRCUIT DIAGRAM <b>CHAPTER 13</b> CONNECTOR BODY COMPOSITE - MATING VIEW SHOWN																																																																			
AFTERTREATMENT SENSOR (6720) (LOCATED ON LEFT SIDE OF ENGINE)																																																																							
			<table border="1" style="width:100%; border-collapse: collapse;"> <thead> <tr> <th>CAV</th> <th>CIRCUIT</th> <th>GAUGE</th> <th>COLOR</th> <th>TERMINAL</th> </tr> </thead> <tbody> <tr><td>1</td><td>K95A</td><td>18</td><td>TN</td><td>3613771C1</td></tr> <tr><td>2</td><td>K95-GA</td><td>18</td><td>WH</td><td>3613771C1</td></tr> <tr><td>3</td><td>K95B</td><td>18</td><td>TN</td><td>3613771C1</td></tr> <tr><td>4</td><td>K95-GB</td><td>18</td><td>WH</td><td>3613771C1</td></tr> <tr><td>5</td><td>K95C</td><td>18</td><td>TN</td><td>3613771C1</td></tr> <tr><td>6</td><td>K95-GC</td><td>18</td><td>WH</td><td>3613771C1</td></tr> <tr><td>7</td><td>K95-GD</td><td>18</td><td>WH</td><td>3613771C1</td></tr> <tr><td>8</td><td>K95E</td><td>18</td><td>TN</td><td>3613771C1</td></tr> <tr><td>9</td><td>K95DA</td><td>18</td><td>TN</td><td>3613771C1</td></tr> <tr><td>10</td><td>PLUG</td><td>-</td><td>-</td><td>3573076C1</td></tr> </tbody> </table>			CAV	CIRCUIT	GAUGE	COLOR	TERMINAL	1	K95A	18	TN	3613771C1	2	K95-GA	18	WH	3613771C1	3	K95B	18	TN	3613771C1	4	K95-GB	18	WH	3613771C1	5	K95C	18	TN	3613771C1	6	K95-GC	18	WH	3613771C1	7	K95-GD	18	WH	3613771C1	8	K95E	18	TN	3613771C1	9	K95DA	18	TN	3613771C1	10	PLUG	-	-	3573076C1											
CAV	CIRCUIT	GAUGE	COLOR	TERMINAL																																																																			
1	K95A	18	TN	3613771C1																																																																			
2	K95-GA	18	WH	3613771C1																																																																			
3	K95B	18	TN	3613771C1																																																																			
4	K95-GB	18	WH	3613771C1																																																																			
5	K95C	18	TN	3613771C1																																																																			
6	K95-GC	18	WH	3613771C1																																																																			
7	K95-GD	18	WH	3613771C1																																																																			
8	K95E	18	TN	3613771C1																																																																			
9	K95DA	18	TN	3613771C1																																																																			
10	PLUG	-	-	3573076C1																																																																			
CONNECTOR 3690369C1																																																																							
AFTERTREATMENT SENSOR (6720A) (LOCATED ON LEFT SIDE OF ENGINE)																																																																							
			<table border="1" style="width:100%; border-collapse: collapse;"> <thead> <tr> <th>CAV</th> <th>CIRCUIT</th> <th>GAUGE</th> <th>COLOR</th> <th>TERMINAL</th> </tr> </thead> <tbody> <tr><td>1</td><td>K95A</td><td>18</td><td>TN</td><td>3613771C1</td></tr> <tr><td>2</td><td>K95-GA</td><td>18</td><td>WH</td><td>3613771C1</td></tr> <tr><td>3</td><td>K95B</td><td>18</td><td>TN</td><td>3613771C1</td></tr> <tr><td>4</td><td>K95-GB</td><td>18</td><td>WH</td><td>3613771C1</td></tr> <tr><td>5</td><td>K95C</td><td>18</td><td>TN</td><td>3613771C1</td></tr> <tr><td>6</td><td>K95-GC</td><td>18</td><td>WH</td><td>3613771C1</td></tr> <tr><td>7</td><td>K95-GD</td><td>18</td><td>WH</td><td>3613771C1</td></tr> <tr><td>8</td><td>K95E</td><td>18</td><td>TN</td><td>3613771C1</td></tr> <tr><td>9</td><td>K95DA</td><td>18</td><td>TN</td><td>3613771C1</td></tr> <tr><td>10</td><td>PLUG</td><td>-</td><td>-</td><td>3573076C1</td></tr> </tbody> </table>			CAV	CIRCUIT	GAUGE	COLOR	TERMINAL	1	K95A	18	TN	3613771C1	2	K95-GA	18	WH	3613771C1	3	K95B	18	TN	3613771C1	4	K95-GB	18	WH	3613771C1	5	K95C	18	TN	3613771C1	6	K95-GC	18	WH	3613771C1	7	K95-GD	18	WH	3613771C1	8	K95E	18	TN	3613771C1	9	K95DA	18	TN	3613771C1	10	PLUG	-	-	3573076C1											
CAV	CIRCUIT	GAUGE	COLOR	TERMINAL																																																																			
1	K95A	18	TN	3613771C1																																																																			
2	K95-GA	18	WH	3613771C1																																																																			
3	K95B	18	TN	3613771C1																																																																			
4	K95-GB	18	WH	3613771C1																																																																			
5	K95C	18	TN	3613771C1																																																																			
6	K95-GC	18	WH	3613771C1																																																																			
7	K95-GD	18	WH	3613771C1																																																																			
8	K95E	18	TN	3613771C1																																																																			
9	K95DA	18	TN	3613771C1																																																																			
10	PLUG	-	-	3573076C1																																																																			
CONNECTOR 3690369C1			W/ 11L AND 13L IBB ENGINE																																																																				
AFTERTREATMENT SENSOR (6720A) (LOCATED ON LEFT SIDE OF ENGINE)																																																																							
			<table border="1" style="width:100%; border-collapse: collapse;"> <thead> <tr> <th>CAV</th> <th>CIRCUIT</th> <th>GAUGE</th> <th>COLOR</th> <th>TERMINAL</th> <th>SEAL/SLEEVE</th> </tr> </thead> <tbody> <tr><td>A</td><td>K95A</td><td>18</td><td>TN</td><td>1661875C1</td><td>3568570C1</td></tr> <tr><td>B</td><td>K95-GA</td><td>18</td><td>WH</td><td>1661875C1</td><td>3568570C1</td></tr> <tr><td>C</td><td>K95B</td><td>18</td><td>TN</td><td>1661875C1</td><td>3568570C1</td></tr> <tr><td>D</td><td>K95-GB</td><td>18</td><td>WH</td><td>1661875C1</td><td>3568570C1</td></tr> <tr><td>E</td><td>K95C</td><td>18</td><td>TN</td><td>1661875C1</td><td>3568570C1</td></tr> <tr><td>F</td><td>K95-GC</td><td>18</td><td>WH</td><td>1661875C1</td><td>3568570C1</td></tr> <tr><td>G</td><td>K95-GD</td><td>18</td><td>WH</td><td>1661875C1</td><td>3568570C1</td></tr> <tr><td>H</td><td>K95E</td><td>18</td><td>TN</td><td>1661875C1</td><td>3568570C1</td></tr> <tr><td>J</td><td>K95DA</td><td>18</td><td>TN</td><td>1661875C1</td><td>3568570C1</td></tr> <tr><td>K</td><td>PLUG</td><td>-</td><td>-</td><td>2025431C1</td><td>3568570C1</td></tr> </tbody> </table>			CAV	CIRCUIT	GAUGE	COLOR	TERMINAL	SEAL/SLEEVE	A	K95A	18	TN	1661875C1	3568570C1	B	K95-GA	18	WH	1661875C1	3568570C1	C	K95B	18	TN	1661875C1	3568570C1	D	K95-GB	18	WH	1661875C1	3568570C1	E	K95C	18	TN	1661875C1	3568570C1	F	K95-GC	18	WH	1661875C1	3568570C1	G	K95-GD	18	WH	1661875C1	3568570C1	H	K95E	18	TN	1661875C1	3568570C1	J	K95DA	18	TN	1661875C1	3568570C1	K	PLUG	-	-	2025431C1	3568570C1
CAV	CIRCUIT	GAUGE	COLOR	TERMINAL	SEAL/SLEEVE																																																																		
A	K95A	18	TN	1661875C1	3568570C1																																																																		
B	K95-GA	18	WH	1661875C1	3568570C1																																																																		
C	K95B	18	TN	1661875C1	3568570C1																																																																		
D	K95-GB	18	WH	1661875C1	3568570C1																																																																		
E	K95C	18	TN	1661875C1	3568570C1																																																																		
F	K95-GC	18	WH	1661875C1	3568570C1																																																																		
G	K95-GD	18	WH	1661875C1	3568570C1																																																																		
H	K95E	18	TN	1661875C1	3568570C1																																																																		
J	K95DA	18	TN	1661875C1	3568570C1																																																																		
K	PLUG	-	-	2025431C1	3568570C1																																																																		
CONNECTOR 3538635C1 BODY LOCK 3538636C1			W/ 15L IBB ENGINE																																																																				
CHK	DATE	CHANGE	REV	REFERENCE	DRAWN	NAME																																																																	
012	17APR13	REVISED & UPDATED.	C	91786V	300371	CIRCUIT DIAGRAM, PAYSTAR																																																																	
					RELEASE NO.	DATE																																																																	
					61879Y	17SEP09																																																																	
					PART NO.	SHEET																																																																	
					AE08058092	108																																																																	

Figure 326 Connector Composites (6720 / 6720A)



13.140. CONNECTOR COMPOSITES (6720B / 6730 / 6748 / 7000), P. 109

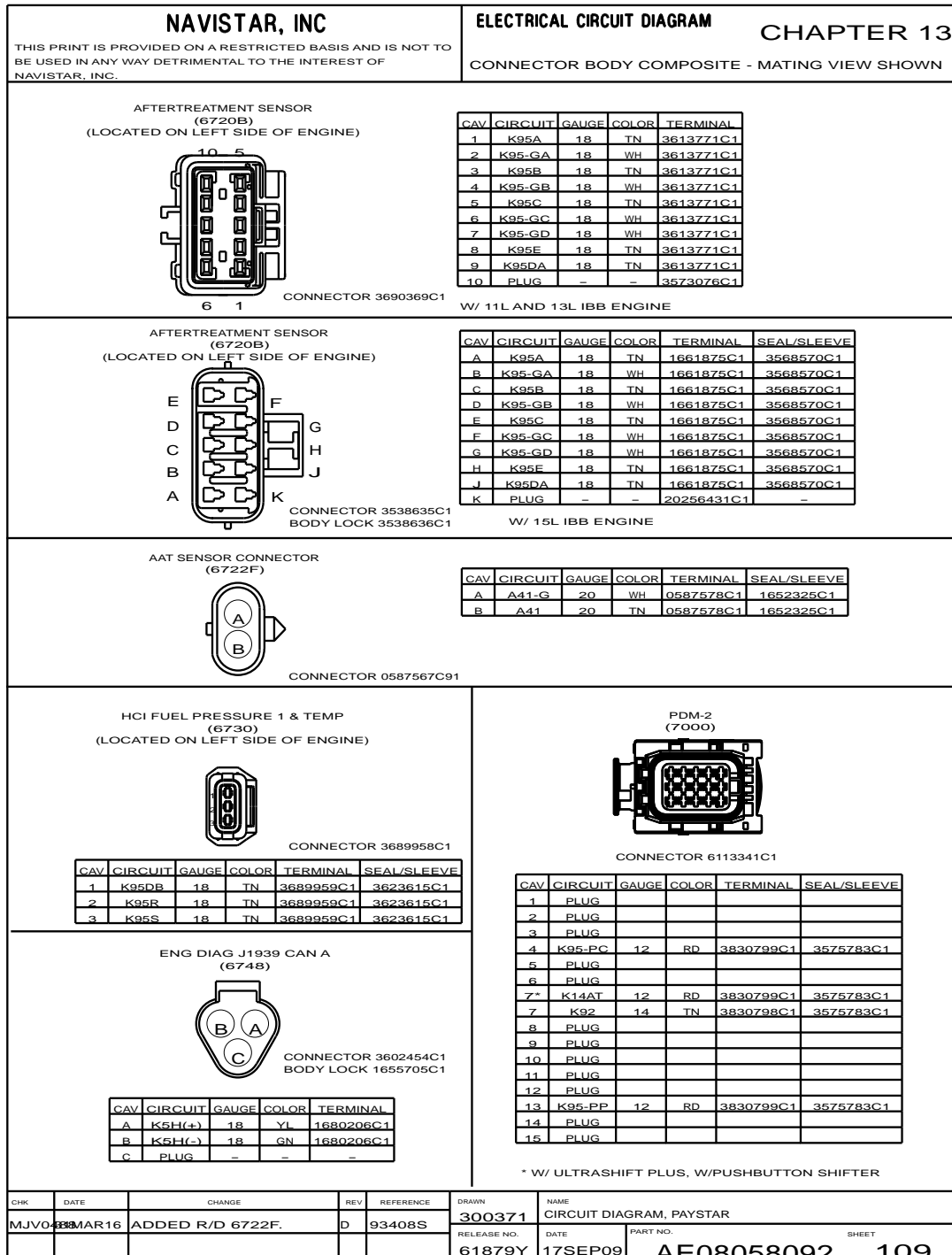


Figure 327 Connector Composites (6720B / 6730 / 6748 / 7000)

13.141. CONNECTOR COMPOSITES (7104 / 7001), P. 110

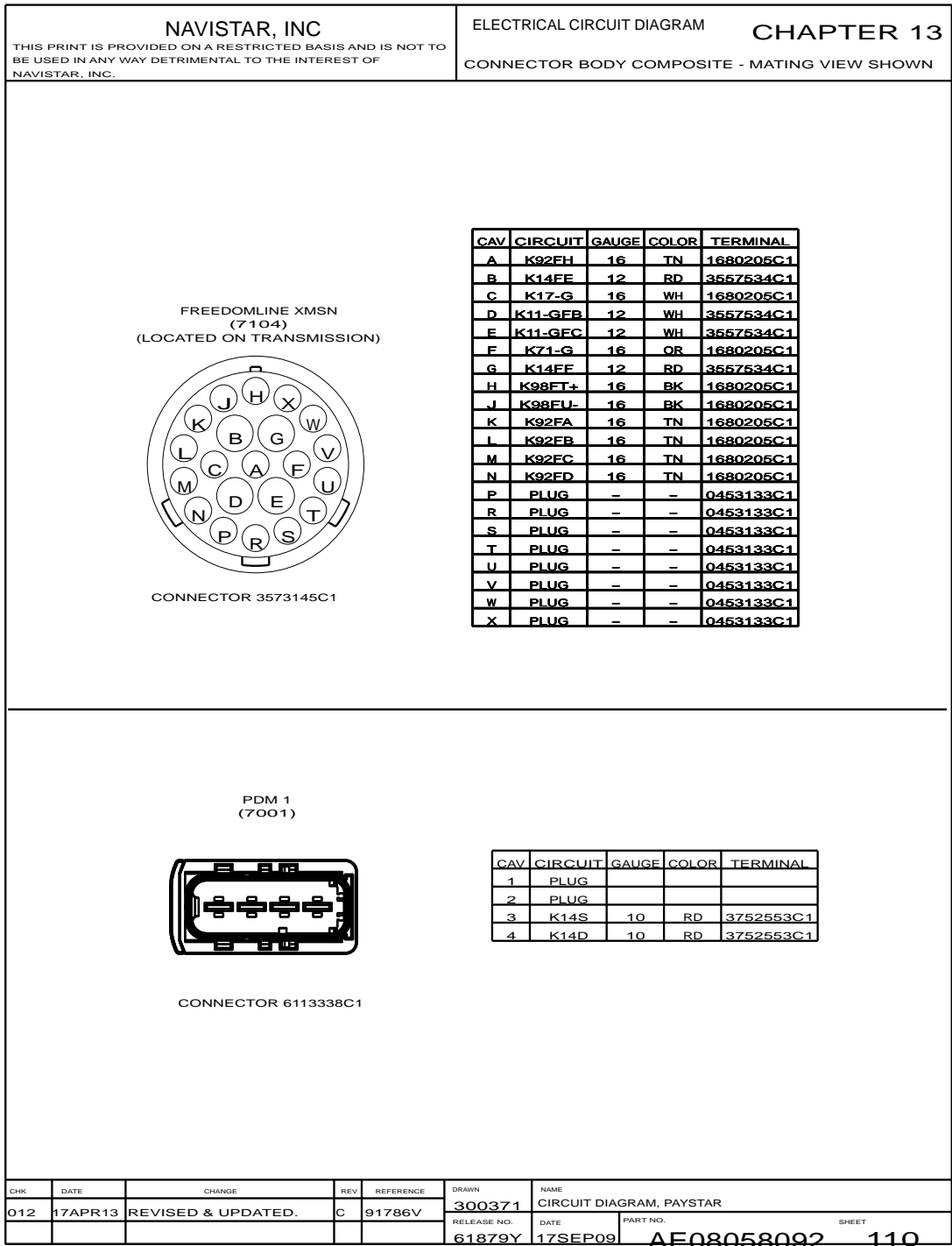


Figure 328 Connector Composites (7104 / 7001)

13.142. CONNECTOR COMPOSITES (7105 / 7110), P. 111

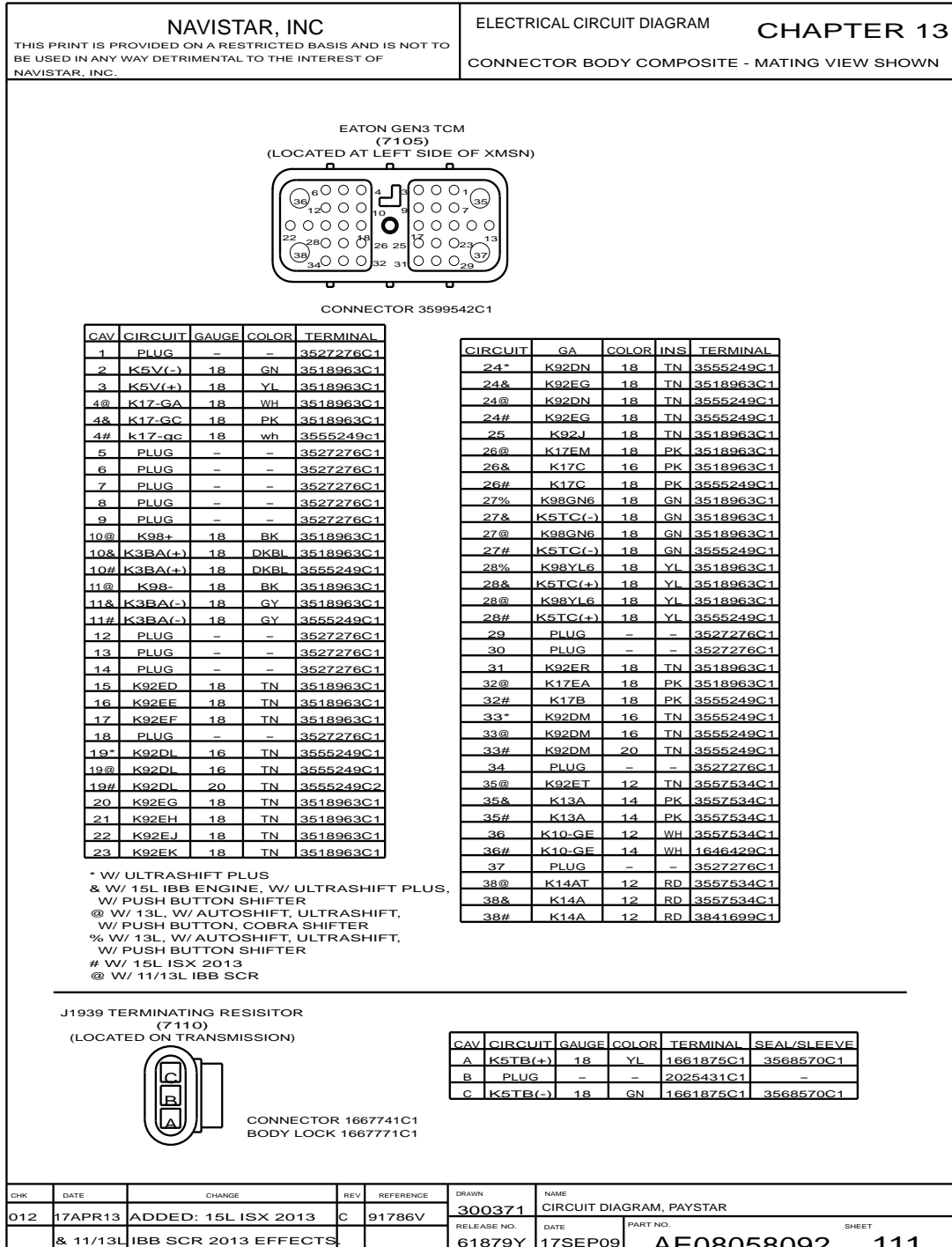


Figure 329 Connector Composites (7105 / 7110)

13.143. CONNECTOR COMPOSITES (7150), P. 112

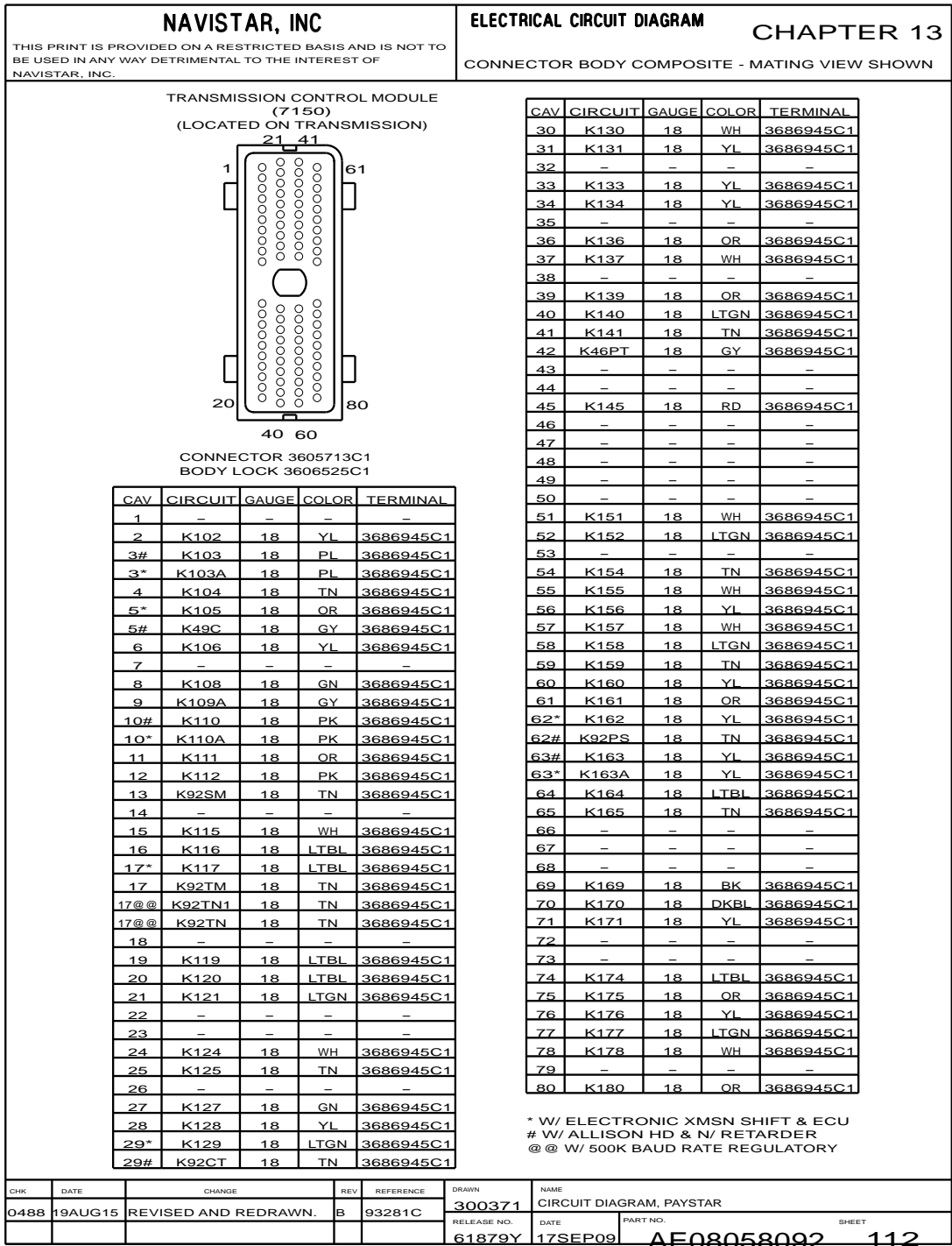


Figure 330 Connector Composites (7150)

13.144. CONNECTOR COMPOSITES (7211 / 7212 / 7213 / 7250), P. 113

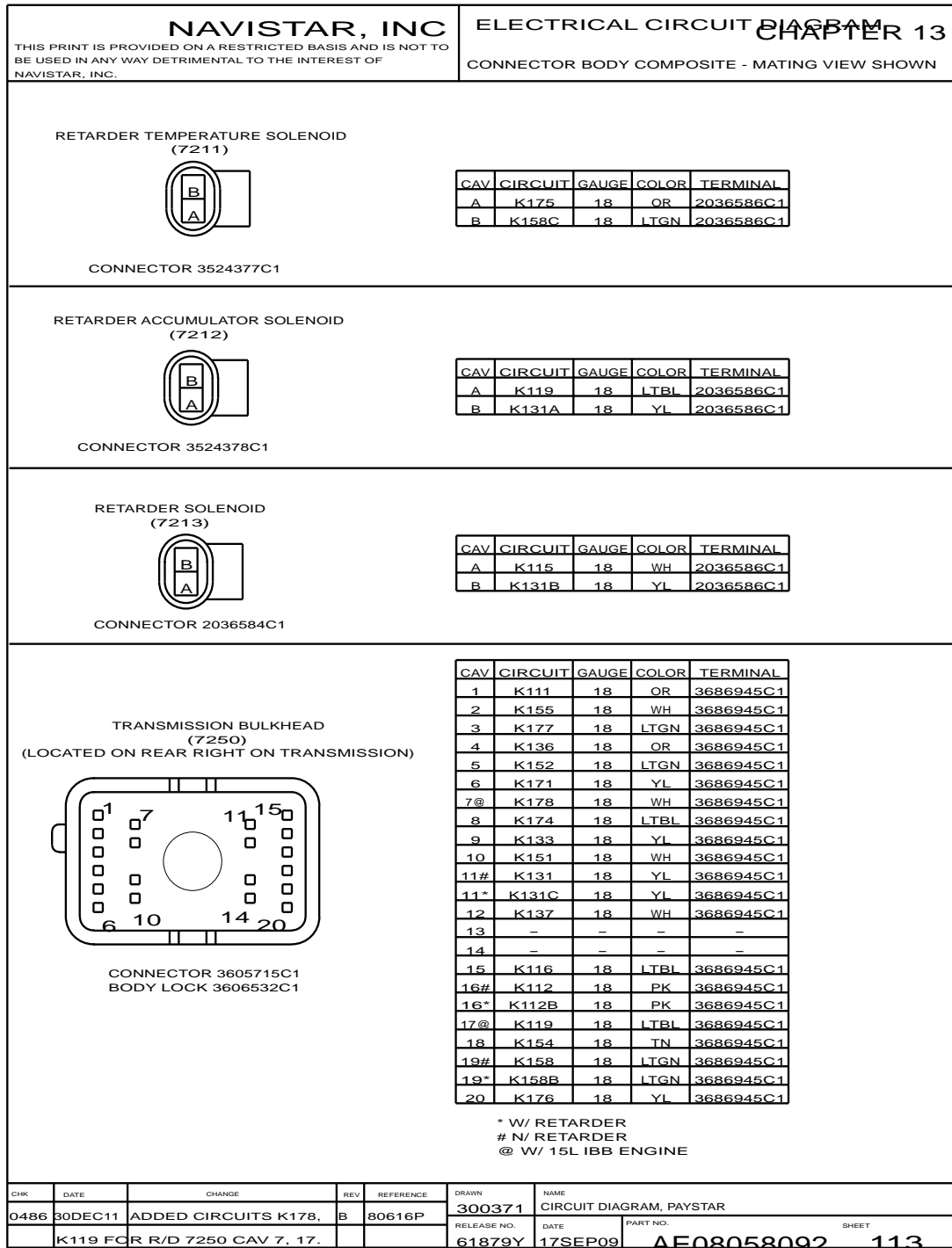


Figure 331 Connector Composites (7211 / 7212 / 7213 / 7250)

13.145. CONNECTOR COMPOSITES (7500W / 7501 / 7600 / 7601 / 7603 / 7608), P. 114

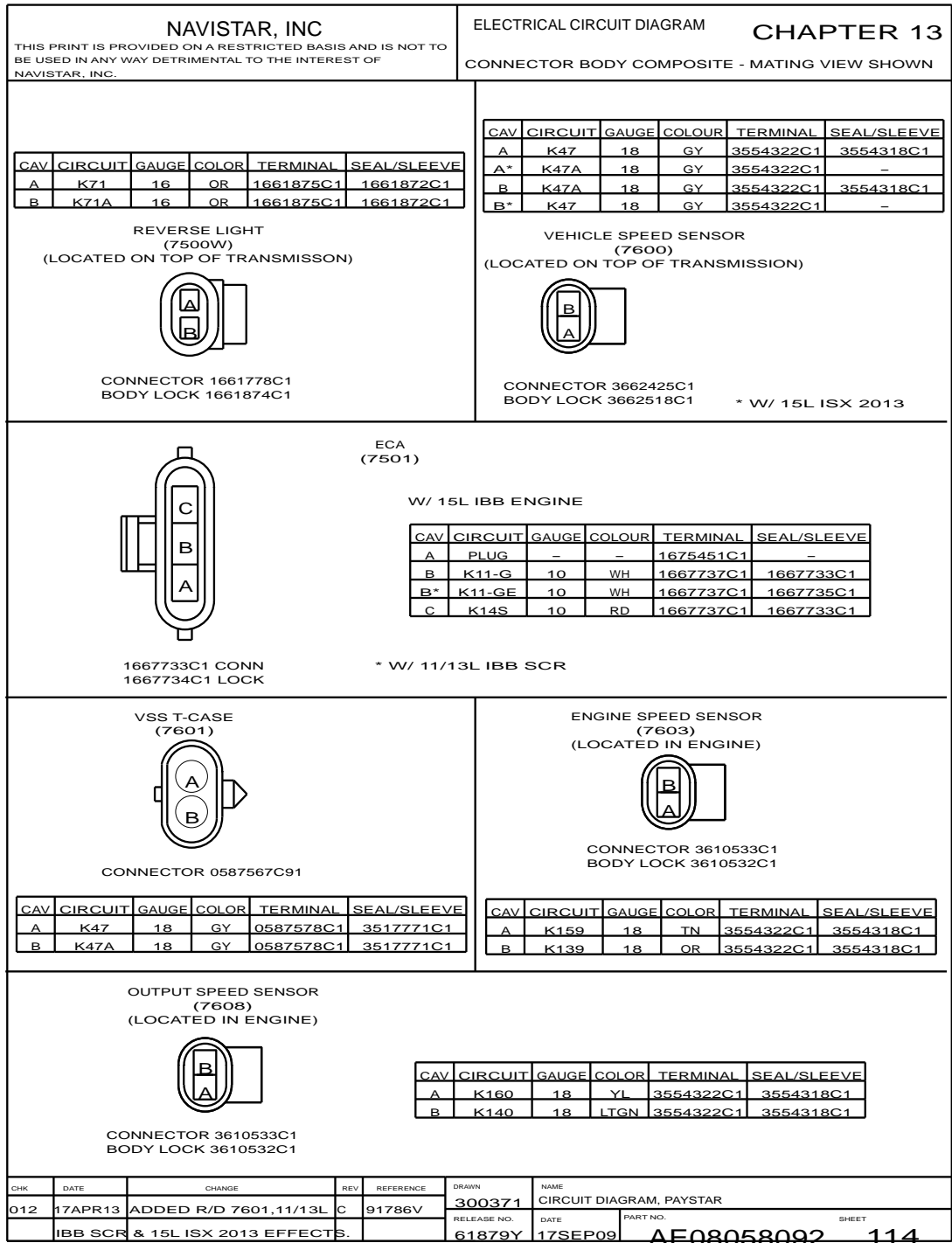


Figure 332 Connector Composites (7500W / 7501 / 7600 / 7601 / 7603 / 7608)

13.146. CONNECTOR COMPOSITES (7615 / 7704 / 7905), P. 115

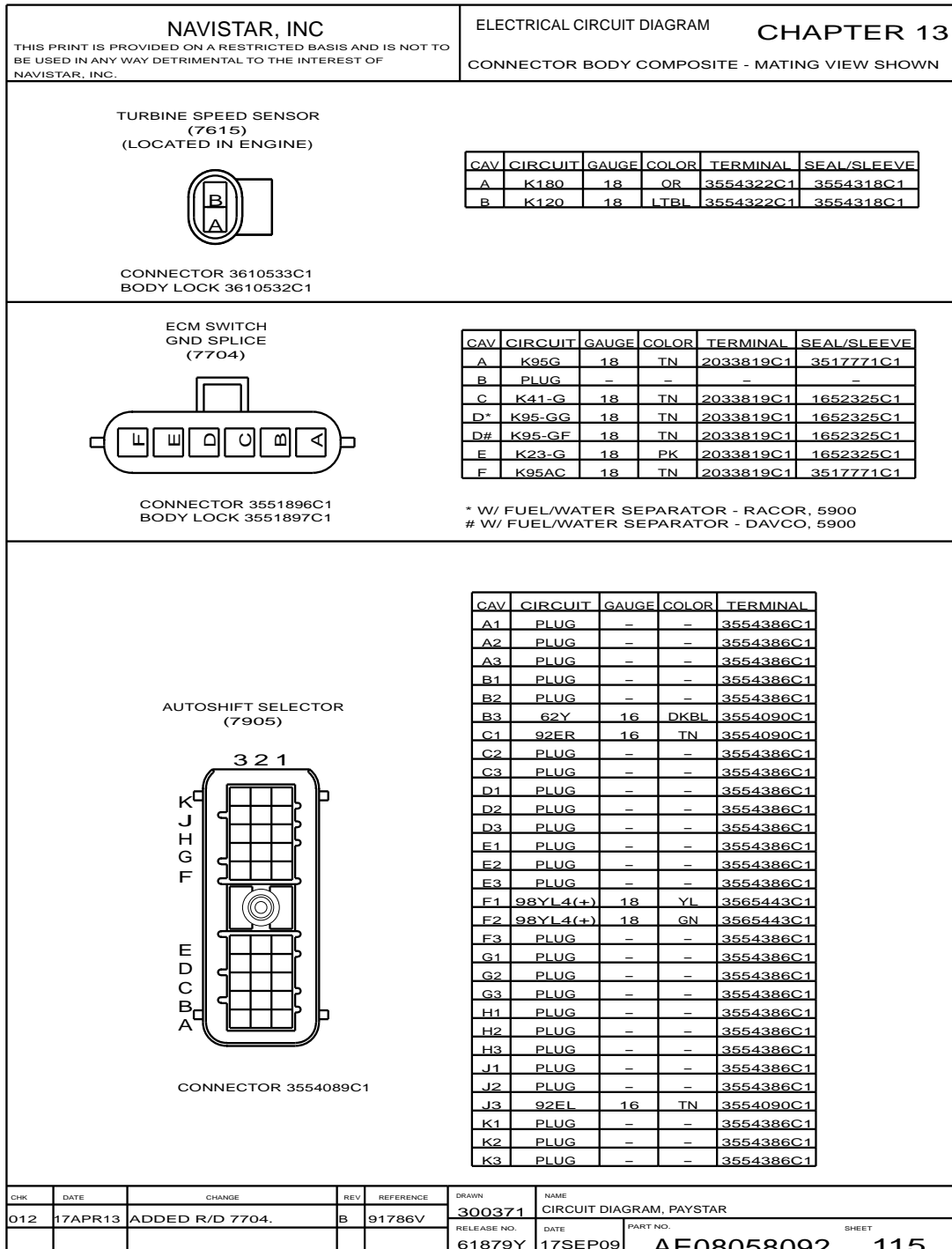


Figure 333 Connector Composites (7615 / 7704 / 7905)

13.147. CONNECTOR COMPOSITES (8102 / 8103 / 8104 / 8107 / 8410), P. 116

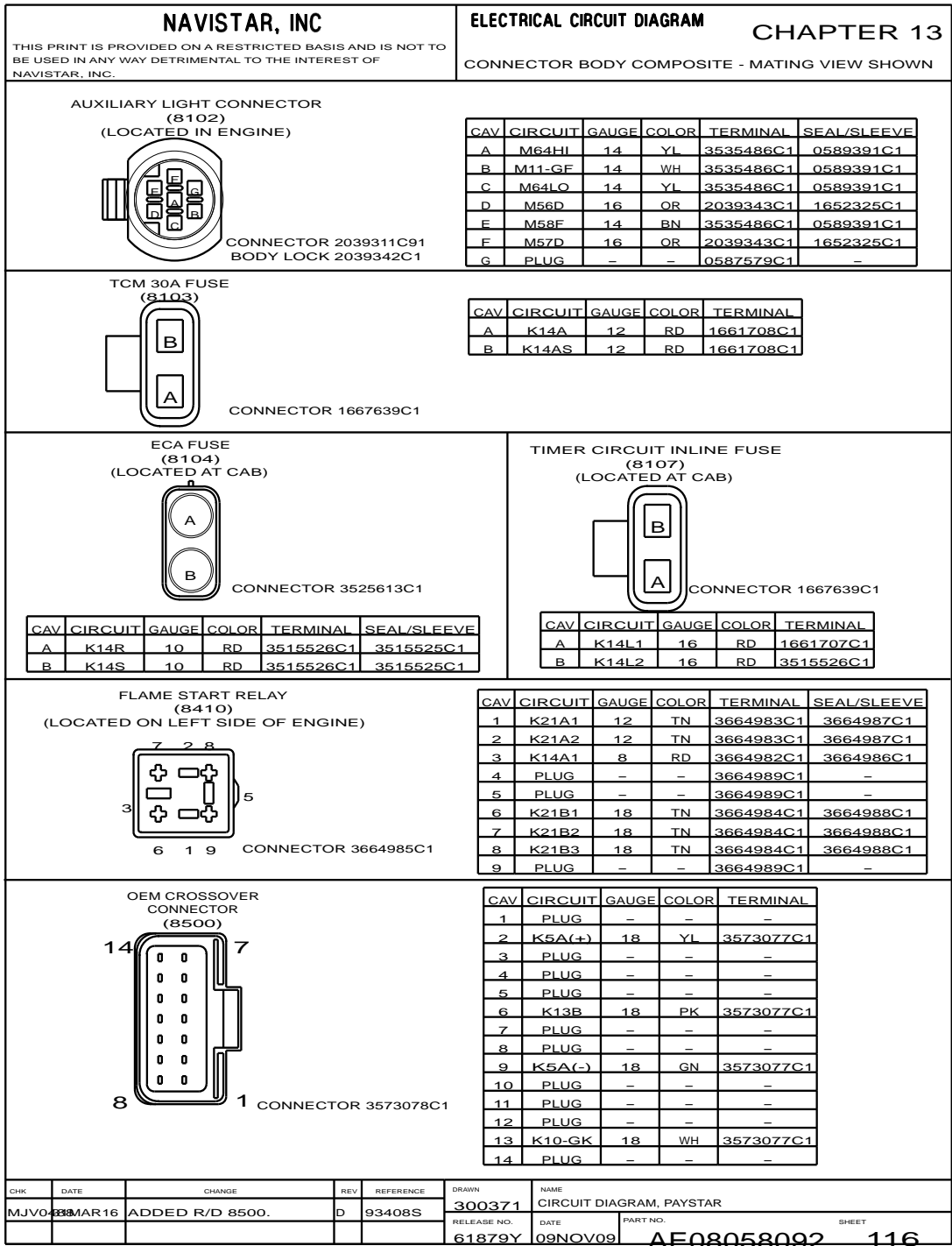


Figure 334 Connector Composites (8102 / 8103 / 8104 / 8107 / 8410)



13.148. CONNECTOR COMPOSITES (8500 / 9762 / 9763 / 9764 / 9765 / 9766), P. 117

NAVISTAR, INC					ELECTRICAL CIRCUIT DIAGRAM									
THIS PRINT IS PROVIDED ON A RESTRICTED BASIS AND IS NOT TO BE USED IN ANY WAY DETRIMENTAL TO THE INTEREST OF NAVISTAR, INC.					CHAPTER 13									
					CONNECTOR BODY COMPOSITE - MATING VIEW SHOWN									
FIRST PUSHER / TAG AXLE (9762) (LOCATED NEAR REAR AXLE)					FIRST PUSHER / TAG AXLE (9762) (LOCATED NEAR REAR AXLE)									
CONNECTOR 0587567C91					CONNECTOR 1661778C1 BODY LOCK 1661874C1									
CAV	CIRCUIT	GAUGE	COLOR	TERMINAL	SEAL/SLEEVE	CAV	CIRCUIT	GAUGE	COLOR	TERMINAL	SEAL/SLEEVE			
A	A59MB	18	GY	0587578C1	1652325C1	A	A59MB	18	GY	1661875C1	1661872C1			
B	A59-GS	18	WH	0587578C1	1652325C1	B%	A59-GM	18	WH	1661875C1	1661872C1			
						B%	A59-GS	18	WH	1661875C1	1661872C1			
* MUTUALLY EXCLUSIVE														
SECOND PUSHER / TAG AXLE (9763) (LOCATED NEAR REAR AXLE)					THIRD PUSHER / TAG AXLE (9764) (LOCATED NEAR REAR AXLE)									
CONNECTOR 1661778C1 BODY LOCK 1661874C1					CONNECTOR 1661778C1 BODY LOCK 1661874C1									
CAV	CIRCUIT	GAUGE	COLOR	TERMINAL	SEAL/SLEEVE	CAV	CIRCUIT	GAUGE	COLOR	TERMINAL	SEAL/SLEEVE			
A	A59NB	18	GY	1661875C1	1661872C1	A	A59PB	18	GY	1661875C1	1661872C1			
B	A59-GN	18	WH	1661875C1	1661872C1	B	A59-GP	18	WH	1661875C1	1661872C1			
* MUTUALLY EXCLUSIVE														
DEF GAUGE IGN FEED (9765)					DEF GAUGE BATTERY FEED (9766)									
CONNECTOR 1667639C1					CONNECTOR 1667639C1									
CAV	CIRCUIT	GAUGE	COLOR	TERMINAL	CAV	CIRCUIT	GAUGE	COLOR	TERMINAL	CAV	CIRCUIT	GAUGE	COLOR	TERMINAL
A	A28NA	18	TN	3895713C1	A	A28N	18	TN	3895713C1	A	A12P	18	LT BL	3895713C1
B	A14NA	18	RD	3895713C1	B	A13NA	18	PK	3895713C1	B	A12S	18	LT BL	3895713C1
* MUTUALLY EXCLUSIVE														
BODY CTRL BATT FEED (9767)					BODY CTRL ACC FEED (9768)									
CONNECTOR 3512967C1					CONNECTOR 3565207C1									
CAV	CIRCUIT	GAUGE	COLOR	TERMINAL	CAV	CIRCUIT	GAUGE	COLOR	TERMINAL	CAV	CIRCUIT	GAUGE	COLOR	TERMINAL
A*	A14N	10	RD	3679001C1	A	A12P	18	LT BL	3895713C1	A	A12P	18	LT BL	3895713C1
A*	A14N	10	GY	3679001C1	B	A12S	18	LT BL	3895713C1	B	A12S	18	LT BL	3895713C1
B	A14P	10	RD	3679001C1										
* MUTUALLY EXCLUSIVE														
CHK	DATE	CHANGE	REV	REFERENCE	DRAWN	NAME						SHEET		
MJV	03MAR16	ADDED R/D 9767,9768	C	93408S	300011	CIRCUIT DIAGRAM, PAYSTAR						117		
		AND RMD R/D 8500.			80616P	RELEASE NO.	DATE	PART NO.						
							20JUN11	AE08058092						

Figure 335 Connector Composites (8500 / 9762 / 9763 / 9764 / 9765 / 9766)

13.149. CONNECTOR COMPOSITES (351A / 352A / 353A / 354A), P. 118



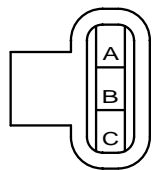
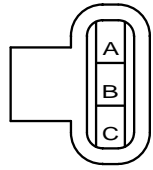
<b>NAVISTAR, INC</b> <small>THIS PRINT IS PROVIDED ON A RESTRICTED BASIS AND IS NOT TO BE USED IN ANY WAY DETRIMENTAL TO THE INTEREST OF NAVISTAR, INC.</small>				ELECTRICAL CIRCUIT DIAGRAM <b>CHAPTER 13</b> CONNECTOR BODY COMPOSITE - MATING VIEW SHOWN																									
<p><b>BENDIX LEFT REAR REAR WHEEL SPEED SENSOR (351A)</b></p>  <table border="1" style="margin-left: auto; margin-right: auto; border-collapse: collapse;"> <thead> <tr> <th>CAV</th> <th>CIRCUIT</th> <th>GAUGE</th> <th>COLOR</th> <th>TERMINAL</th> </tr> </thead> <tbody> <tr> <td>1</td> <td>GY/WH2</td> <td>16</td> <td>GY</td> <td>1651969C1</td> </tr> <tr> <td>2</td> <td>OR/WH2</td> <td>16</td> <td>OR</td> <td>1651969C1</td> </tr> </tbody> </table> <p>CONNECTOR 3539777C1 BODY LOCK 3539784C1</p>						CAV	CIRCUIT	GAUGE	COLOR	TERMINAL	1	GY/WH2	16	GY	1651969C1	2	OR/WH2	16	OR	1651969C1									
CAV	CIRCUIT	GAUGE	COLOR	TERMINAL																									
1	GY/WH2	16	GY	1651969C1																									
2	OR/WH2	16	OR	1651969C1																									
<p><b>BENDIX RIGHT REAR REAR WHEEL SPEED SENSOR (352A)</b></p>  <table border="1" style="margin-left: auto; margin-right: auto; border-collapse: collapse;"> <thead> <tr> <th>CAV</th> <th>CIRCUIT</th> <th>GAUGE</th> <th>COLOR</th> <th>TERMINAL</th> </tr> </thead> <tbody> <tr> <td>1</td> <td>DKBL/WH2</td> <td>16</td> <td>DKBL</td> <td>1651969C1</td> </tr> <tr> <td>2</td> <td>YL/WH2</td> <td>16</td> <td>YL</td> <td>1651969C1</td> </tr> </tbody> </table> <p>CONNECTOR 3539777C1 BODY LOCK 3539784C1</p>						CAV	CIRCUIT	GAUGE	COLOR	TERMINAL	1	DKBL/WH2	16	DKBL	1651969C1	2	YL/WH2	16	YL	1651969C1									
CAV	CIRCUIT	GAUGE	COLOR	TERMINAL																									
1	DKBL/WH2	16	DKBL	1651969C1																									
2	YL/WH2	16	YL	1651969C1																									
<p><b>BENDIX LEFT REAR REAR MODULATOR VALVE (353A)</b></p>  <table border="1" style="margin-left: auto; margin-right: auto; border-collapse: collapse;"> <thead> <tr> <th>CAV</th> <th>CIRCUIT</th> <th>GAUGE</th> <th>COLOR</th> <th>TERMINAL</th> <th>SEAL/SLV</th> </tr> </thead> <tbody> <tr> <td>A</td> <td>VT/WH2</td> <td>16</td> <td>VT</td> <td>2033819C1</td> <td>1652325C1</td> </tr> <tr> <td>B</td> <td>LTGN/WH2</td> <td>16</td> <td>LTGN</td> <td>2033819C1</td> <td>1652325C1</td> </tr> <tr> <td>C</td> <td>LTBL/WH2</td> <td>16</td> <td>LTBL</td> <td>2033819C1</td> <td>1652325C1</td> </tr> </tbody> </table> <p>CONNECTOR 1686834C1 BODY LOCK 1664408C1</p>						CAV	CIRCUIT	GAUGE	COLOR	TERMINAL	SEAL/SLV	A	VT/WH2	16	VT	2033819C1	1652325C1	B	LTGN/WH2	16	LTGN	2033819C1	1652325C1	C	LTBL/WH2	16	LTBL	2033819C1	1652325C1
CAV	CIRCUIT	GAUGE	COLOR	TERMINAL	SEAL/SLV																								
A	VT/WH2	16	VT	2033819C1	1652325C1																								
B	LTGN/WH2	16	LTGN	2033819C1	1652325C1																								
C	LTBL/WH2	16	LTBL	2033819C1	1652325C1																								
<p><b>BENDIX RIGHT REAR REAR MODULATOR VALVE (354A)</b></p>  <table border="1" style="margin-left: auto; margin-right: auto; border-collapse: collapse;"> <thead> <tr> <th>CAV</th> <th>CIRCUIT</th> <th>GAUGE</th> <th>COLOR</th> <th>TERMINAL</th> <th>SEAL/SLV</th> </tr> </thead> <tbody> <tr> <td>A</td> <td>BK/WH2</td> <td>16</td> <td>BK</td> <td>2033819C1</td> <td>1652325C1</td> </tr> <tr> <td>B</td> <td>RD/WH2</td> <td>16</td> <td>RD</td> <td>2033819C1</td> <td>1652325C1</td> </tr> <tr> <td>C</td> <td>BN/WH2</td> <td>16</td> <td>BN</td> <td>2033819C1</td> <td>1652325C1</td> </tr> </tbody> </table> <p>CONNECTOR 1686834C1 BODY LOCK 1664408C1</p>						CAV	CIRCUIT	GAUGE	COLOR	TERMINAL	SEAL/SLV	A	BK/WH2	16	BK	2033819C1	1652325C1	B	RD/WH2	16	RD	2033819C1	1652325C1	C	BN/WH2	16	BN	2033819C1	1652325C1
CAV	CIRCUIT	GAUGE	COLOR	TERMINAL	SEAL/SLV																								
A	BK/WH2	16	BK	2033819C1	1652325C1																								
B	RD/WH2	16	RD	2033819C1	1652325C1																								
C	BN/WH2	16	BN	2033819C1	1652325C1																								
CHK	DATE	CHANGE	REV	REFERENCE	DRAWN	NAME																							
012	15JAN13	INITIAL RELEASE.	A	91749L	310706	CIRCUIT DIAGRAM, PAYSTAR																							
					RELEASE NO.	DATE																							
					91749L	07JAN13																							
					PART NO.	SHEET																							
					AE08058092	118																							

Figure 336 Connector Composites (351A / 352A / 353A / 354A)

13.150. CONNECTOR COMPOSITES (445 / 453 / 580M / 690A), P. 119

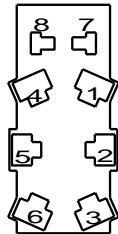


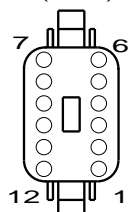
<b>NAVISTAR, INC</b>				<b>ELECTRICAL CIRCUIT DIAGRAM</b>		<b>CHAPTER 13</b>																																																								
THIS PRINT IS PROVIDED ON A RESTRICTED BASIS AND IS NOT TO BE USED IN ANY WAY DETRIMENTAL TO THE INTEREST OF NAVISTAR, INC.				CONNECTOR BODY COMPOSITE - MATING VIEW SHOWN																																																										
<p>HILL START AID SWITCH (445)</p>  <p>CONNECTOR 2009385C1</p>				<table border="1" style="width: 100%; border-collapse: collapse; font-size: x-small;"> <thead> <tr> <th>CAV</th> <th>CIRCUIT</th> <th>GAUGE</th> <th>COLOR</th> <th>TERMINAL</th> </tr> </thead> <tbody> <tr><td>1</td><td>-</td><td>-</td><td>-</td><td>-</td></tr> <tr><td>2</td><td>-</td><td>-</td><td>-</td><td>-</td></tr> <tr><td>3</td><td>-</td><td>-</td><td>-</td><td>-</td></tr> <tr><td>4</td><td>-</td><td>-</td><td>-</td><td>-</td></tr> <tr><td>5</td><td>11-G</td><td>16</td><td>WH</td><td>1661227C1</td></tr> <tr><td>5</td><td>94-GC</td><td>16</td><td>WH</td><td>1661227C1</td></tr> <tr><td>6</td><td>94CC</td><td>16</td><td>GY</td><td>1661226C1</td></tr> <tr><td>7</td><td>62AK</td><td>16</td><td>DKBL</td><td>1661209C1</td></tr> <tr><td>8</td><td>94-GC</td><td>16</td><td>WH</td><td>1661209C1</td></tr> </tbody> </table>				CAV	CIRCUIT	GAUGE	COLOR	TERMINAL	1	-	-	-	-	2	-	-	-	-	3	-	-	-	-	4	-	-	-	-	5	11-G	16	WH	1661227C1	5	94-GC	16	WH	1661227C1	6	94CC	16	GY	1661226C1	7	62AK	16	DKBL	1661209C1	8	94-GC	16	WH	1661209C1					
CAV	CIRCUIT	GAUGE	COLOR	TERMINAL																																																										
1	-	-	-	-																																																										
2	-	-	-	-																																																										
3	-	-	-	-																																																										
4	-	-	-	-																																																										
5	11-G	16	WH	1661227C1																																																										
5	94-GC	16	WH	1661227C1																																																										
6	94CC	16	GY	1661226C1																																																										
7	62AK	16	DKBL	1661209C1																																																										
8	94-GC	16	WH	1661209C1																																																										
<p>G1 GND ADAPTER (453)</p>  <p>CONNECTOR 2007315C1 BODY LOCK 2007316C1</p>				<p>HILL START AID LAMP (580M)</p>  <p>CONNECTOR 0969541R1</p>																																																										
<table border="1" style="width: 100%; border-collapse: collapse; font-size: x-small;"> <thead> <tr> <th>CAV</th> <th>CIRCUIT</th> <th>GAUGE</th> <th>COLOR</th> <th>TERMINAL</th> </tr> </thead> <tbody> <tr><td>A-B</td><td>-</td><td>-</td><td>-</td><td>-</td></tr> <tr><td>C</td><td>11GR</td><td>16</td><td>WH</td><td>1661209C1</td></tr> <tr><td>D-G</td><td>-</td><td>-</td><td>-</td><td>-</td></tr> <tr><td>H</td><td>11-G</td><td>16</td><td>WH</td><td>1661209C1</td></tr> </tbody> </table>				CAV	CIRCUIT	GAUGE	COLOR	TERMINAL	A-B	-	-	-	-	C	11GR	16	WH	1661209C1	D-G	-	-	-	-	H	11-G	16	WH	1661209C1	<table border="1" style="width: 100%; border-collapse: collapse; font-size: x-small;"> <thead> <tr> <th>CAV</th> <th>CIRCUIT</th> <th>GAUGE</th> <th>COLOR</th> <th>TERMINAL</th> </tr> </thead> <tbody> <tr><td>A</td><td>94CF</td><td>18</td><td>PK</td><td>0333732C1</td></tr> <tr><td>B</td><td>94CG</td><td>18</td><td>GY</td><td>0333732C1</td></tr> <tr><td>A</td><td>94CF</td><td>16</td><td>PK</td><td>0333732C1</td></tr> <tr><td>B</td><td>94CG</td><td>16</td><td>GY</td><td>0333733C1</td></tr> </tbody> </table>				CAV	CIRCUIT	GAUGE	COLOR	TERMINAL	A	94CF	18	PK	0333732C1	B	94CG	18	GY	0333732C1	A	94CF	16	PK	0333732C1	B	94CG	16	GY	0333733C1					
CAV	CIRCUIT	GAUGE	COLOR	TERMINAL																																																										
A-B	-	-	-	-																																																										
C	11GR	16	WH	1661209C1																																																										
D-G	-	-	-	-																																																										
H	11-G	16	WH	1661209C1																																																										
CAV	CIRCUIT	GAUGE	COLOR	TERMINAL																																																										
A	94CF	18	PK	0333732C1																																																										
B	94CG	18	GY	0333732C1																																																										
A	94CF	16	PK	0333732C1																																																										
B	94CG	16	GY	0333733C1																																																										
<p>6-CH ABS CONNECTOR (690A)</p>  <p>CONNECTOR 3519423C1</p>				<table border="1" style="width: 100%; border-collapse: collapse; font-size: x-small;"> <thead> <tr> <th>CAV</th> <th>CIRCUIT</th> <th>GAUGE</th> <th>COLOR</th> <th>TERMINAL</th> </tr> </thead> <tbody> <tr><td>1</td><td>GY/WH2</td><td>16</td><td>GY</td><td>1680205C1</td></tr> <tr><td>2</td><td>OR/WH2</td><td>16</td><td>OR</td><td>1680205C1</td></tr> <tr><td>3</td><td>DKBL/WH2</td><td>16</td><td>DKBL</td><td>1680205C1</td></tr> <tr><td>4</td><td>YL/WH2</td><td>16</td><td>YL</td><td>1680205C1</td></tr> <tr><td>7</td><td>BN/WH2</td><td>16</td><td>BN</td><td>1680205C1</td></tr> <tr><td>8</td><td>RD/WH2</td><td>16</td><td>RD</td><td>1680205C1</td></tr> <tr><td>9</td><td>BK/WH2</td><td>16</td><td>BK</td><td>1680205C1</td></tr> <tr><td>10</td><td>LTBL/WH2</td><td>16</td><td>LTBL</td><td>1680205C1</td></tr> <tr><td>11</td><td>LTGN/WH2</td><td>16</td><td>LTGN</td><td>1680205C1</td></tr> <tr><td>12</td><td>VT/WH2</td><td>16</td><td>VT</td><td>1680205C1</td></tr> </tbody> </table>				CAV	CIRCUIT	GAUGE	COLOR	TERMINAL	1	GY/WH2	16	GY	1680205C1	2	OR/WH2	16	OR	1680205C1	3	DKBL/WH2	16	DKBL	1680205C1	4	YL/WH2	16	YL	1680205C1	7	BN/WH2	16	BN	1680205C1	8	RD/WH2	16	RD	1680205C1	9	BK/WH2	16	BK	1680205C1	10	LTBL/WH2	16	LTBL	1680205C1	11	LTGN/WH2	16	LTGN	1680205C1	12	VT/WH2	16	VT	1680205C1
CAV	CIRCUIT	GAUGE	COLOR	TERMINAL																																																										
1	GY/WH2	16	GY	1680205C1																																																										
2	OR/WH2	16	OR	1680205C1																																																										
3	DKBL/WH2	16	DKBL	1680205C1																																																										
4	YL/WH2	16	YL	1680205C1																																																										
7	BN/WH2	16	BN	1680205C1																																																										
8	RD/WH2	16	RD	1680205C1																																																										
9	BK/WH2	16	BK	1680205C1																																																										
10	LTBL/WH2	16	LTBL	1680205C1																																																										
11	LTGN/WH2	16	LTGN	1680205C1																																																										
12	VT/WH2	16	VT	1680205C1																																																										
CHK	DATE	CHANGE	REV	REFERENCE	DRAWN	NAME																																																								
0488	09SEP15	REVISED AND REDRAWN.	B	93248U	310706	CIRCUIT DIAGRAM, PAYSTAR																																																								
					RELEASE NO.	DATE	PART NO.	SHEET																																																						
					91749L	07JAN13	AE08058092	119																																																						

Figure 337 Connector Composites (445 / 453 / 580M / 690A)

13.151. CONNECTOR COMPOSITES (1362 / 9510F / 9513), P. 120


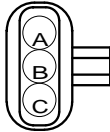
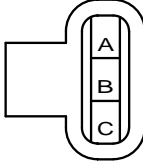
<b>NAVISTAR, INC</b> <small>THIS PRINT IS PROVIDED ON A RESTRICTED BASIS AND IS NOT TO BE USED IN ANY WAY DETRIMENTAL TO THE INTEREST OF NAVISTAR, INC.</small>				ELECTRICAL CIRCUIT DIAGRAM <b>CHAPTER 13</b> CONNECTOR BODY COMPOSITE - MATING VIEW SHOWN																										
<p>RSP AUTO TRACTION CONTROL / FRONT ATC ESP (1362)</p>  <table border="1" style="margin-left: auto; margin-right: auto;"> <thead> <tr> <th>CAV</th> <th>CIRCUIT</th> <th>GAUGE</th> <th>COLOR</th> <th>TERMINAL</th> </tr> </thead> <tbody> <tr> <td>1</td> <td>94SJ</td> <td>16</td> <td>GY</td> <td>3626031C1</td> </tr> <tr> <td>2</td> <td>94SC</td> <td>16</td> <td>GY</td> <td>3626031C1</td> </tr> </tbody> </table> <p>CONNECTOR 3518183C1 BODY LOCK 3518174C1</p>							CAV	CIRCUIT	GAUGE	COLOR	TERMINAL	1	94SJ	16	GY	3626031C1	2	94SC	16	GY	3626031C1									
CAV	CIRCUIT	GAUGE	COLOR	TERMINAL																										
1	94SJ	16	GY	3626031C1																										
2	94SC	16	GY	3626031C1																										
<p>ESP LOAD SENSOR (9510F)</p>  <table border="1" style="margin-left: auto; margin-right: auto;"> <thead> <tr> <th>CAV</th> <th>CIRCUIT</th> <th>GAUGE</th> <th>COLOR</th> <th>TERMINAL</th> <th>SEAL/SLV</th> </tr> </thead> <tbody> <tr> <td>A</td> <td>BL1</td> <td>16</td> <td>LTBL</td> <td>1667742C1</td> <td>1661872C1</td> </tr> <tr> <td>B</td> <td>GN1</td> <td>16</td> <td>LTGN</td> <td>1667742C1</td> <td>1661872C1</td> </tr> <tr> <td>C</td> <td>BN1</td> <td>16</td> <td>BN</td> <td>1667742C1</td> <td>1661872C1</td> </tr> </tbody> </table> <p>CONNECTOR 1667740C1 BODY LOCK 1667771C1</p>							CAV	CIRCUIT	GAUGE	COLOR	TERMINAL	SEAL/SLV	A	BL1	16	LTBL	1667742C1	1661872C1	B	GN1	16	LTGN	1667742C1	1661872C1	C	BN1	16	BN	1667742C1	1661872C1
CAV	CIRCUIT	GAUGE	COLOR	TERMINAL	SEAL/SLV																									
A	BL1	16	LTBL	1667742C1	1661872C1																									
B	GN1	16	LTGN	1667742C1	1661872C1																									
C	BN1	16	BN	1667742C1	1661872C1																									
<p>TRAILER MODULATOR VALVE (9513)</p>  <table border="1" style="margin-left: auto; margin-right: auto;"> <thead> <tr> <th>CAV</th> <th>CIRCUIT</th> <th>GAUGE</th> <th>COLOR</th> <th>TERMINAL</th> <th>SEAL/SLV</th> </tr> </thead> <tbody> <tr> <td>A</td> <td>BK/WH3</td> <td>16</td> <td>BK</td> <td>2033819C1</td> <td>1652325C1</td> </tr> <tr> <td>B</td> <td>RD/WH3</td> <td>16</td> <td>RD</td> <td>2033819C1</td> <td>1652325C1</td> </tr> <tr> <td>C</td> <td>BN/WH3</td> <td>16</td> <td>BN</td> <td>2033819C1</td> <td>1652325C1</td> </tr> </tbody> </table> <p>CONNECTOR 1686834C1 BODY LOCK 1664408C1</p>							CAV	CIRCUIT	GAUGE	COLOR	TERMINAL	SEAL/SLV	A	BK/WH3	16	BK	2033819C1	1652325C1	B	RD/WH3	16	RD	2033819C1	1652325C1	C	BN/WH3	16	BN	2033819C1	1652325C1
CAV	CIRCUIT	GAUGE	COLOR	TERMINAL	SEAL/SLV																									
A	BK/WH3	16	BK	2033819C1	1652325C1																									
B	RD/WH3	16	RD	2033819C1	1652325C1																									
C	BN/WH3	16	BN	2033819C1	1652325C1																									
CHK	DATE	CHANGE	REV	REFERENCE	DRAWN	NAME																								
012	15JAN13	INITIAL RELEASE.	A	91749L	310706	CIRCUIT DIAGRAM, PAYSTAR																								
					RELEASE NO.	DATE																								
					91749L	07JAN13																								
					PART NO.	SHEET																								
					AE08058092	120																								

Figure 338 Connector Composites (1362 / 9510F / 9513)