



Run Smart™

CASCADIA®



Driver's Manual

Introduction

This manual provides information needed to operate and understand the vehicle and its components. More detailed information is contained in the *Owner's Warranty Information for North America* booklet, and in the vehicle's workshop and maintenance manuals.

Custom-built Freightliner vehicles are equipped with various chassis and cab components. Not all of the information contained in this manual applies to every vehicle. For details about components in your vehicle, refer to the chassis specification pages included in all new vehicles and to the vehicle specification decal, located inside the vehicle.

For your reference, keep this manual in the vehicle at all times.

IMPORTANT: Descriptions and specifications in this manual were in effect at the time of printing. Freightliner Trucks reserves the right to discontinue models and to change specifications or design at any time without notice and without incurring obligation. Descriptions and specifications contained in this publication provide no warranty, expressed or implied, and are subject to revisions and editions without notice.

Environmental Concerns and Recommendations

Whenever you see instructions in this manual to discard materials, you should first attempt to reclaim and recycle them. To preserve our environment, follow appropriate environmental rules and regulations when disposing of materials.

Event Data Recorder

This vehicle is equipped with one or more devices that record specific vehicle data. The type and amount of data recorded varies depending on how the vehicle is equipped (such as the brand of engine, if an air bag is installed, or if the vehicle features a collision avoidance system, etc.).

This vehicle is equipped with an event data recorder (EDR). The main purpose of an EDR is to record data in certain crash or near-crash situations, such as air bag deployment or hitting a road obstacle, that will assist in understanding how a vehicle's systems

performed. The EDR is designed to record data related to vehicle dynamics and safety systems for approximately 60 seconds. This data can help provide a better understanding of the circumstances in which crashes and injuries occur. Data recorded includes the following items:

- how various systems in the vehicle were operating
- engine system information
- how far (if at all) the driver was depressing the accelerator
- if the driver was depressing the brake pedal
- how fast the vehicle was traveling

NOTE: Data is not recorded by the EDR under normal driving conditions. Personal data such as name, gender, age, and crash location are not recorded. However, other parties such as law enforcement could combine the EDR data with the type of personally identifying data routinely acquired during a crash investigation.

To read data recorded by an EDR, special equipment is required, and access to the vehicle or the EDR is needed. In addition to the vehicle manufacturer, other parties that have the special equipment, such as law enforcement, can read the information if they have access to the vehicle or the EDR.

Emissions and Fuel Efficiency Compliance

This vehicle must be regularly inspected and maintained as indicated in the *Cascadia Maintenance Manual*, and in the *Pre- and Post-Trip Inspections and Maintenance* chapter in this manual, in order to continue satisfactory performance and ensure coverage of the vehicle under the manufacturer's warranty. Many maintenance procedures ensure that the vehicle and engine continue to comply with applicable emissions standards. Maintenance procedures, using components engineered to comply with greenhouse gas emissions and fuel efficiency regulations, may be performed by an authorized Daimler Trucks North America dealer, an independent outlet, or the vehicle owner or operator.

The vehicle owner is responsible for determining the suitability of replacement components to maintain

Foreword

compliance with federal and local jurisdictional regulations. Components including, but not limited to, tires, cab/sleeper side extenders, chassis fairings, bumper, hood, vehicle speed limiters, and idle reduction timers are specifically designed and manufactured to exacting standards for regulatory fuel efficiency and greenhouse gas emissions compliance. It is important that these components are always replaced with components that meet or exceed the performance of the originally installed components.

hotline 1-800-333-0510, or contact Transport Canada by mail at: Transport Canada, ASFAD, Place de Ville Tower C, 330 Sparks Street, Ottawa, Ontario, Canada K1A 0N5.

For additional road safety information, please visit the Road Safety website at: www.tc.gc.ca/roadsafety.

Customer Assistance Center

Having trouble finding service? Call the Customer Assistance Center at 1-800-385-4357 or 1-800-FTL-HELP. Call night or day, weekdays or weekends, for dealer referral, vehicle information, breakdown coordination, or Fleetpack assistance. Our people are knowledgeable, professional, and committed to following through to help you keep your truck moving.

Reporting Safety Defects

If you believe that your vehicle has a defect which could cause a crash or could cause injury or death, you should immediately inform the National Highway Traffic Safety Administration (NHTSA) in addition to notifying Daimler Trucks North America LLC.

If the NHTSA receives similar complaints, it may open an investigation, and if it finds that a safety defect exists in a group of vehicles, it may order a recall and remedy campaign. However, NHTSA cannot become involved in individual problems between you, your dealer, or Daimler Trucks North America LLC.

To contact NHTSA, you may call the Vehicle Safety Hotline toll-free at 1-888-327-4236 (TTY: 1-800-424-9153); go to www.safercar.gov; or write to: Administrator, NHTSA, 1200 New Jersey Avenue, SE, Washington, DC 20590. You can also obtain other information about motor vehicle safety from www.safercar.gov.

Canadian customers who wish to report a safety-related defect to Transport Canada, Defect Investigations and Recalls, may telephone the toll-free

© 2007–2015 Daimler Trucks North America LLC. All rights reserved. Daimler Trucks North America LLC is a Daimler company.

No part of this publication, in whole or part, may be translated, reproduced, stored in a retrieval system, or transmitted in any form by any means, electronic, mechanical, photocopying, recording, or otherwise, without the prior written permission of Daimler Trucks North America LLC. For additional information, please contact Daimler Trucks North America LLC, Service Systems and Documentation, P.O. Box 3849, Portland OR 97208–3849 U.S.A. or refer to www.Daimler-TrucksNorthAmerica.com and www.FreightlinerTrucks.com.

Contents

| Chapter | | Page |
|---------|---|----------|
| | Introduction, Environmental Concerns and Recommendations, Event Data Recorder, Emissions and Fuel Efficiency Compliance, Customer Assistance Center, Reporting Safety Defects | Foreword |
| 1 | Vehicle Identification | 1.1 |
| 2 | Vehicle Access | 2.1 |
| 3 | Electrical System | 3.1 |
| 4 | Instruments | 4.1 |
| 5 | Driver Controls | 5.1 |
| 6 | Driver Assistance Features | 6.1 |
| 7 | Seats and Restraints | 7.1 |
| 8 | Climate Control | 8.1 |
| 9 | Cab Features | 9.1 |
| 10 | Engine Starting, Operation, and Shutdown | 10.1 |
| 11 | Optional Engine Systems | 11.1 |
| 12 | Emissions and Fuel Efficient Components | 12.1 |
| 13 | Brake Systems | 13.1 |
| 14 | Manual Transmissions and Hydraulic Clutch | 14.1 |
| 15 | Automated Transmissions | 15.1 |
| 16 | Drive Axles | 16.1 |
| 17 | Steering System | 17.1 |
| 18 | Fifth Wheels | 18.1 |
| 19 | Trailer Couplings | 19.1 |
| 20 | Pre- and Post-Trip Checklists | 20.1 |
| 21 | Pre- and Post-Trip Inspections and Maintenance | 21.1 |
| 22 | Cab Appearance | 22.1 |
| 23 | Headlight Aiming | 23.1 |
| 24 | In an Emergency | 24.1 |
| 25 | Natural Gas Vehicles | 25.1 |
| 26 | Specifications | 26.1 |
| | Index | I.1 |

1

Vehicle Identification

| | |
|---|-----|
| Component Information Label | 1.1 |
| Component GWR Label | 1.1 |
| Federal Motor Vehicle Safety Standard Labels | 1.1 |
| Canadian Motor Vehicle Safety Standard Labels | 1.1 |
| Emissions Labels | 1.1 |

Vehicle Identification

| MAXIMUM GWR BY COMPONENT (KG)/LB | COMPONENT | FRONT AXLE | 1ST INT | 2ND INT | 3RD INT | 4TH INT | 5TH INT | 6TH INT | REAR AXLE | COMPONENT GWR |
|----------------------------------|-------------|---------------|---------------|---------------|---------------|---------------|---------------|---------------|---------------|---------------------------|
| | AXLE | (12345) 12345 | (12345) 12345 | (12345) 12345 | (12345) 12345 | (12345) 12345 | (12345) 12345 | (12345) 12345 | (12345) 12345 | CHASSIS (12345) 12345 |
| | SUSPENSION | (12345) 12345 | (12345) 12345 | (12345) 12345 | (12345) 12345 | (12345) 12345 | (12345) 12345 | (12345) 12345 | (12345) 12345 | ENG/TRANS (12345) 12345 |
| | TIRES | (12345) 12345 | (12345) 12345 | (12345) 12345 | (12345) 12345 | (12345) 12345 | (12345) 12345 | (12345) 12345 | (12345) 12345 | 5TH WHL (12345) 12345 |
| | RIMS | (12345) 12345 | (12345) 12345 | (12345) 12345 | (12345) 12345 | (12345) 12345 | (12345) 12345 | (12345) 12345 | (12345) 12345 | PARK BRAKE (12345) 12345 |
| | HUBS/SPOKES | (12345) 12345 | (12345) 12345 | (12345) 12345 | (12345) 12345 | (12345) 12345 | (12345) 12345 | (12345) 12345 | (12345) 12345 | AXLE (12345) 12345 |
| | BRAKES | (12345) 12345 | (12345) 12345 | (12345) 12345 | (12345) 12345 | (12345) 12345 | (12345) 12345 | (12345) 12345 | (12345) 12345 | VIN 12345678901234567 |
| | STEERING | (12345) 12345 | (12345) 12345 | (12345) 12345 | (12345) 12345 | (12345) 12345 | (12345) 12345 | (12345) 12345 | (12345) 12345 | PHI NO. 24 0117 430 REY 1 |

02/20/2012 f080178

Fig. 1.2, Component GWR Label

| | | | | | | | | | | |
|--|---|---|---|---------------------------|------------------|------------------------------|--------------------------|------------|------------|---------------|
| THIS VEHICLE CONFORMS TO ALL APPLICABLE FEDERAL MOTOR VEHICLE SAFETY STANDARDS IN EFFECT AT DATE OF MANUFACTURE NOTED. | TYPE: TRUCK TRACTOR/TI/CT MANUFACTURED BY VEHICLE ID NO DATE OF MFR GWR/PWB/NG GWR/PWB/LBS | FREIGHTLINER LLC XX 22 CHARACTERS XX 1234567890123456789012 1234567890123456789012 1234567890123456789012 | FRONT AXLE FIRST INT AXLE SECOND INT AXLE THIRD INT AXLE FOURTH INT AXLE FIFTH INT AXLE SIXTH INT AXLE REAR AXLE | GWR/PWB/NG | GWR/PWB/LBS | TIRES | RIMS | WPA COLD | PST COLD | "S"STEEL/DUAL |
| | | | | 6 CHAR 123456 | 6 CHAR 123456 | XX 14 CHAR 12345678901234 | X 10CHAR X 1234567890 | X3X 123 | X3X 123 | |
| MADE IN CANADA | | L | | PHI NO. 24 0117 430 REY 1 | | | | | | |

02/20/2012 f080177

Fig. 1.3, Vehicle Certification Label

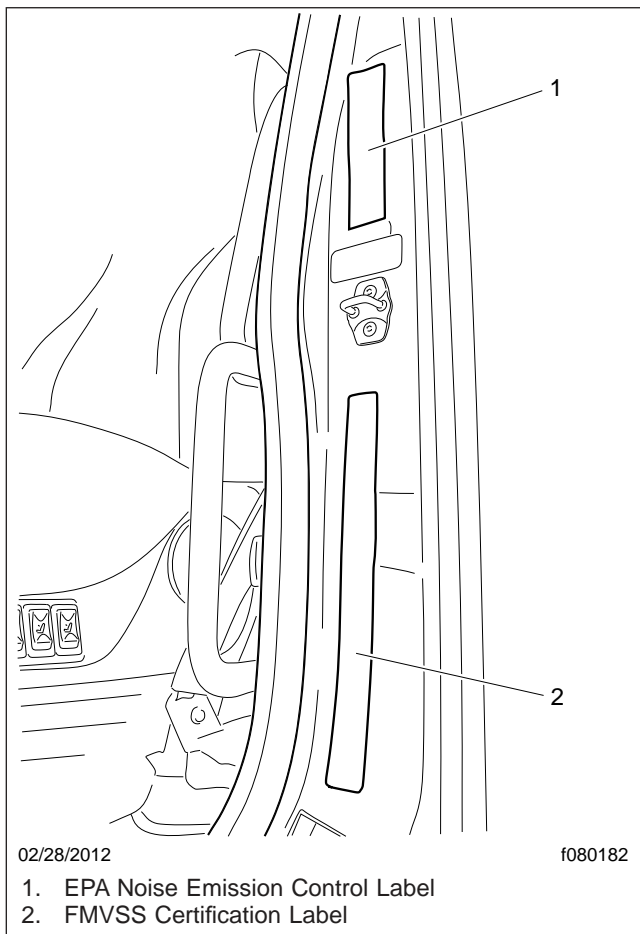

Fig. 1.4, Label Locations

| | | | | | | | | | | |
|-----------------|---------------------|--------------|--------|---------|--------|------------|------------|------------|------------|------------|
| MANUFACTURED BY | FREIGHTLINER LLC | FRONT AXLE | 6 CHAR | GWR/NG | 6 CHAR | TIRES | XX 14 CHAR | RIMS | XX 14 CHAR | XX 9CHAR |
| VIN | XX 22 CHARACTERS XX | 1ST INT AXLE | 6 CHAR | GWR/LBS | 6 CHAR | XX 14 CHAR | XX 14 CHAR | XX 14 CHAR | XX 14 CHAR | XX 9CHAR X |
| NO YR OF MFR | XX 25 CHARACTERS XX | 2ND INT AXLE | 6 CHAR | | 6 CHAR | XX 14 CHAR | XX 14 CHAR | XX 14 CHAR | XX 14 CHAR | XX 9CHAR X |
| GWR/NG | XX 22 CHARACTERS XX | 3RD INT AXLE | 6 CHAR | | 6 CHAR | XX 14 CHAR | XX 14 CHAR | XX 14 CHAR | XX 14 CHAR | XX 9CHAR X |
| GWR/LBS | XX 22 CHARACTERS XX | 4TH INT AXLE | 6 CHAR | | 6 CHAR | XX 14 CHAR | XX 14 CHAR | XX 14 CHAR | XX 14 CHAR | XX 9CHAR X |
| | | 5TH INT AXLE | 6 CHAR | | 6 CHAR | XX 14 CHAR | XX 14 CHAR | XX 14 CHAR | XX 14 CHAR | XX 9CHAR X |
| | | 6TH INT AXLE | 6 CHAR | | 6 CHAR | XX 14 CHAR | XX 14 CHAR | XX 14 CHAR | XX 14 CHAR | XX 9CHAR X |
| | | REAR AXLE | 6 CHAR | | 6 CHAR | XX 14 CHAR | XX 14 CHAR | XX 14 CHAR | XX 14 CHAR | XX 9CHAR X |

02/28/2012 f080180

Fig. 1.5, Incomplete Vehicle Certification Label









Fig. 1.6, Canadian National Safety Mark

A warning label on the driver-side visor contains important warning indicators in the instrument cluster that pertain to the ATS. See [Fig. 1.7](#) or [Fig. 1.8](#).

It is a violation of U.S. federal law to alter exhaust plumbing, ATS, or other components in any way that would bring the engine/vehicle out of compliance with certification requirements [Ref: 42 U.S.C. S7522(a) (3)]. It is the owner's responsibility to maintain the vehicle so that it conforms to EPA regulations.

Vehicle Identification

| EXHAUST AFTERTREATMENT SYSTEM INFORMATION | | | | | |
|---|--|---|---|--|--|
| INDICATOR LAMP(S) |  (Solid) Level 1 |  (Flashing) Level 2 |  (Flashing) CHECK Level 3 |  STOP Level 4 |  WARNING  |
| Indicator Lamp Message(s) | Filter Regeneration Recommended. | Filter Regeneration Necessary | Parked Regeneration Required – Engine Derate | Service Regeneration Required. Engine Derate To Idle Only. | HEST (High Exhaust System Temperature) |
| Diesel Particulate Filter Condition | Filter is reaching capacity. | Filter is now reaching maximum capacity. | Filter has reached maximum capacity. | Filter has exceeded maximum capacity. | Flashing A regeneration is in progress. |
| Required Action | Bring vehicle to highway speeds to allow for an Automatic Regeneration or perform a Parked Regeneration. | To avoid engine derate, bring vehicle to highway speeds to allow for an Automatic Regeneration, or perform a Parked Regeneration as soon as possible. | Vehicle must be parked, and a Parked Regeneration must be performed. Engine will begin derate. | Vehicle must be parked, and a Service Regeneration must be performed. Check engine operator's manual for details. Engine will shut down. | Solid Exhaust components and exhaust gas are at high temperature. When stationary, keep away from people and flammable materials or vapors. |
| For a driver performed Parked Regeneration, vehicle must be equipped with a dash mounted Regeneration Switch. | | | | | |

02/20/2009

f080156

Fig. 1.7, ATS Indicators, EPA07

| Applicable Emissions System Based on Build Date and EPA Regulations | |
|---|--|
| Build Date | Regulation: Emissions Components |
| January 1, 2007–December 31, 2009 | EPA07 (reduce nitrogen oxides (NOx) emissions to 1.1 g/bhp-hr, and reduce particulate matter emissions to 0.01 g/bhp-hr): Aftertreatment device (ATD) containing a diesel particulate filter that traps soot and ash.* |
| January 1, 2010–December 31, 2012 | EPA10 (reduce NOx emissions to 0.2 g/bhp-hr): EPA07-type ATD, with additional selective catalyst reduction (SCR) technology that utilizes diesel exhaust fluid (DEF) to convert NOx to nitrogen and water vapor. |
| From March 5, 2012 | GHG14: Aerodynamic and fuel efficiency components including, but not limited to, tires, cab/sleeper side extenders, chassis fairings, bumper, hood, vehicle speed limiters, and idle reduction timers specifically designed to meet regulatory fuel efficiency and greenhouse gas emissions standards. |

* Cummins, Detroit, and Mercedes-Benz ATD's are also equipped with a diesel oxidation catalyst to break down pollutants.

Table 1.1, Applicable Emissions System Based on Build Date and EPA Regulations

EPA Noise Emission Control Label

A vehicle noise emission control label (Fig. 1.9) is located on the driver-side B-pillar as shown in Fig. 1.4. It is the owner's responsibility to maintain the vehicle so that it conforms to EPA regulations.

IMPORTANT: Certain Freightliner incomplete vehicles may be produced with incomplete noise control hardware. Such vehicles will not have a vehicle noise emission control information label. For such vehicles, it is the final-stage manufacturer's responsibility to complete the vehicle in conformity to U.S. EPA regulations (40 CFR Part 205) and label it for compliance.

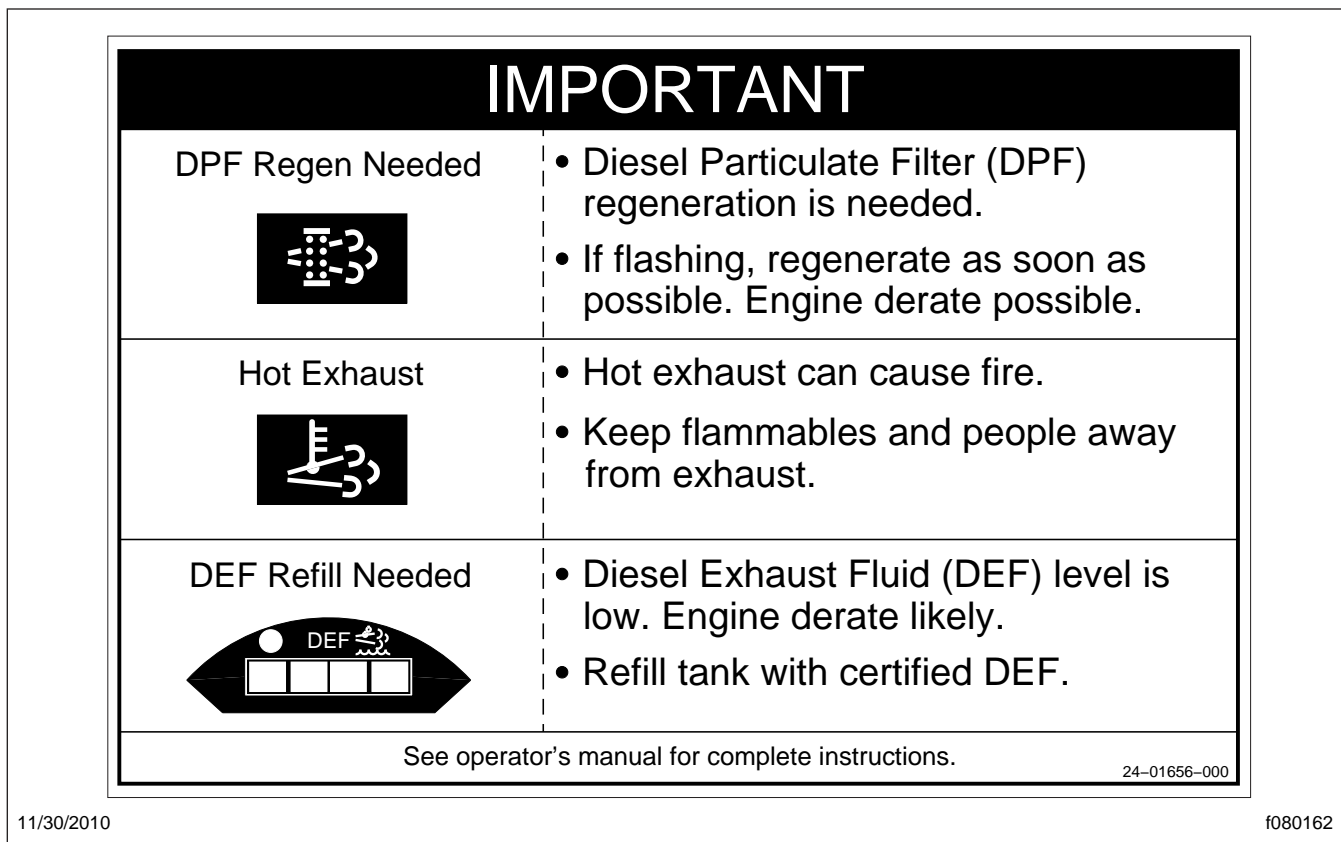

Fig. 1.8, ATS Indicators, EPA10 and Newer

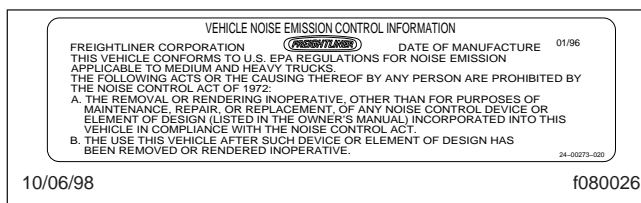

Fig. 1.9, Vehicle Noise Emission Control Label

Vehicle Emission Control Information Label

Model year 2013 and later vehicles meet additional requirements as specified by federal greenhouse gas and fuel efficiency regulations (GHG14). These vehicles are equipped with components that increase fuel efficiency and reduce GHG emissions. Components may include, but are not limited to, low-rolling resistance tires; aerodynamic devices such as hood, cab side extenders, and fuel tank fairings; vehicle speed limiters; and idle shutdown timers.

A Vehicle Emission Control Information Label is located on the driver-side door. See [Fig. 1.10](#). It is the owner's responsibility to maintain the vehicle so that it conforms to EPA and NHTSA regulations.

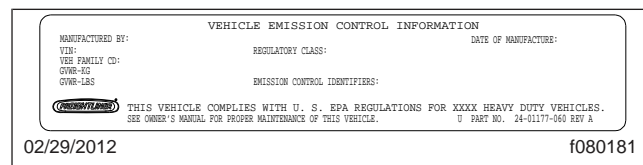

Fig. 1.10, Vehicle Emission Control Information Label

Certified Clean Idle Label

The California Air Resources Board (CARB) requires model year 2008 and newer heavy-duty diesel engines to be equipped with a non-programmable engine shutdown system that automatically shuts down the engine after five minutes of idling in order to limit emissions of particulate matter and NOx.

Vehicle Identification

Certified vehicles are equipped with a label placed near the bottom edge of the driver-side door. See [Fig. 1.11](#).

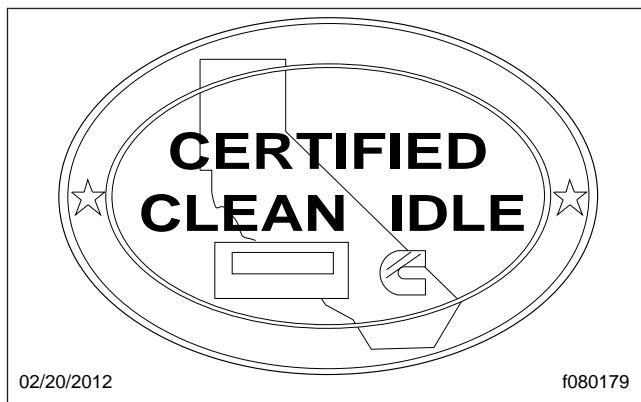

Fig. 1.11, CARB Clean Idle Label

2

Vehicle Access

| | |
|-------------------------------------|-----|
| Cab Door Locks and Handles | 2.1 |
| Grab Handles and Access Steps | 2.1 |
| Cab-to-Sleeper Access | 2.3 |
| Sleeper Door | 2.3 |
| Sleeper Luggage Door | 2.4 |
| Back-of-Cab Access | 2.4 |
| Hood Opening and Closing | 2.5 |

Vehicle Access

Cab Door Locks and Handles

One common key operates the ignition switch and all of the door locks.

IMPORTANT: Each key is numbered. Record the number so a duplicate key can be made, if needed.

To unlock the driver's door from outside the cab, insert the key in the lockset and turn it one-quarter turn clockwise. See [Fig. 2.1](#). To remove the key, turn it counterclockwise to the original position. Pull out on the door pull handle to open the door.

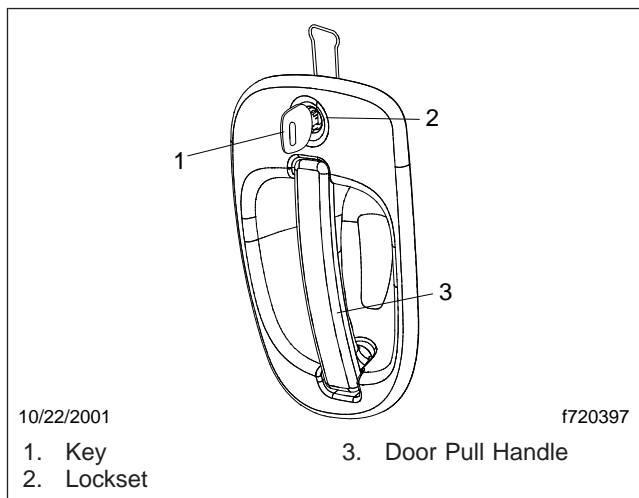

Fig. 2.1, Exterior Door Handle

To unlock the passenger's door from outside the cab, insert the key in the lockset and turn it one-quarter turn counterclockwise. Turn the key clockwise to the original position to remove it.

NOTE: The cab door locks can be operated when the doors are open.

To lock a door from outside the cab, insert the key in the lockset and turn it in the direction opposite to the unlocking direction (counterclockwise for the driver's door, clockwise for the passenger's door). Close the door if it is open.

To lock either door from inside the cab, push the lock button downwards. See [Fig. 2.2](#).

To open the door from the inside, lift up on the door lever. This will unlatch the door whether or not it is locked.

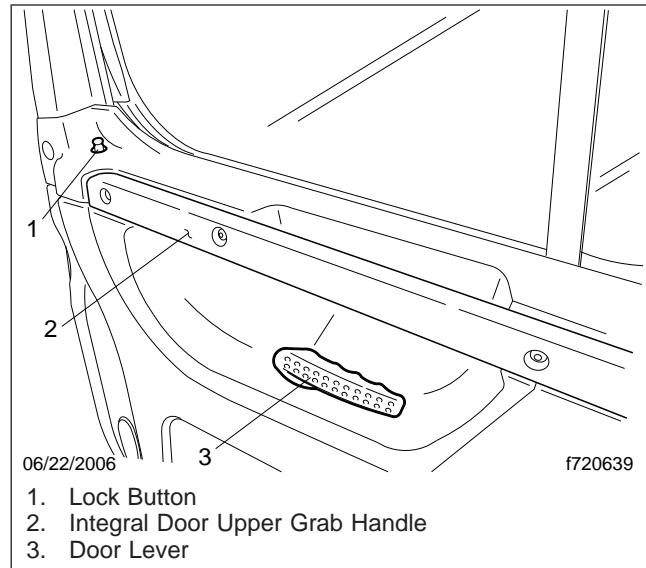

Fig. 2.2, Door Interior

To unlock the door without unlatching it, pull the lock button upwards.

Grab Handles and Access Steps

WARNING

Wet or dirty shoe soles greatly increase the chance of slipping or falling. If your soles are wet or dirty, be especially careful when climbing onto, or down from, the back-of-cab area.

Always maintain three-point contact with the back-of-cab access supports while entering and exiting the back-of-cab area. Three-point contact means both feet and one hand, or both hands and one foot, on the grab handles, steps, and deck plates. Other areas are not meant to support back-of-cab access, and grabbing or stepping in the wrong place could lead to a fall, and personal injury.

Be careful not to get hands or feet tangled in hoses or other back-of-cab equipment. Carelessness could cause a person to trip and fall, with possible injury.

Entering the Driver Side

When entering the cab from the driver side, use the grab handle and access steps as follows:

1. Open the driver side door, and place anything that you are carrying in the cab.
2. Using both hands, grasp the grab handle that is on the B-pillar, or use your left hand on the integral door lower grab handle. See [Fig. 2.3](#). Reach up as far as is comfortable.

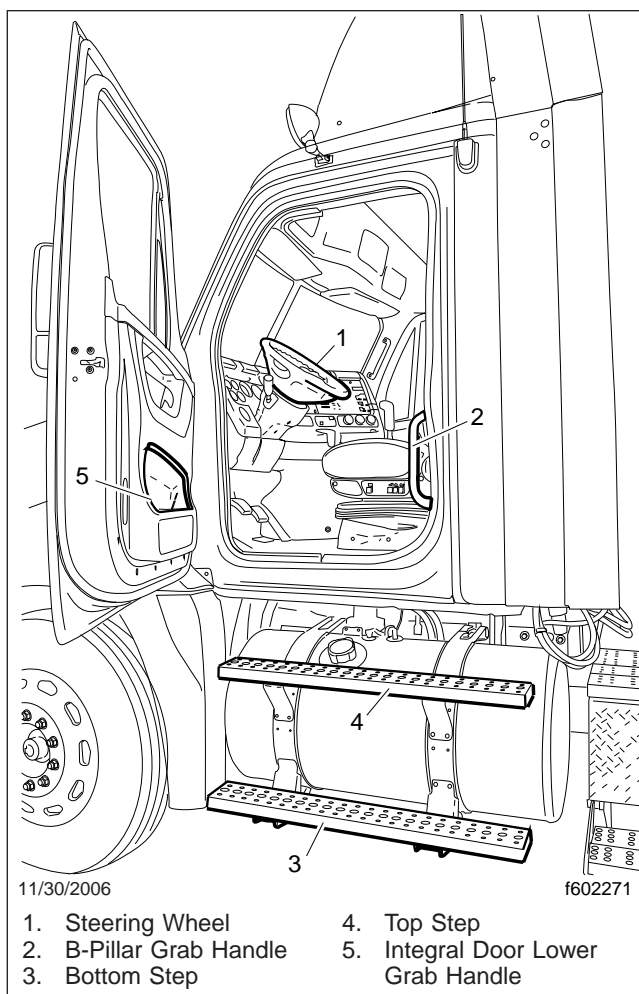

Fig. 2.3, Driver-Side Steps and Grab Handle

3. Place your right foot on the bottom step, and pull yourself up. Move your left hand to the integral door upper grab handle.
4. Place your left foot on the top step.

5. Grasp the steering wheel with your left hand, and step up.
6. Step into the cab with your right foot first, and grasp the steering wheel with your right hand.

Exiting the Driver Side

Exit the cab from the driver side as follows:

IMPORTANT: Do not attempt to exit the cab while carrying any items in your hands.

1. Grasp the steering wheel with both hands, place your left foot on the top step, then stand on the threshold facing into the cab.
2. Using your right hand, grasp the grab handle, located on the B-pillar.
3. Move your right foot to the bottom step.
4. Move your left hand to the integral door lower grab handle.
5. Step to the ground with your left foot first.

Entering the Passenger Side

When entering the cab from the passenger side, use the grab handles and access steps as follows:

1. Open the passenger-side door, and place anything that you are carrying in the cab.
2. Using your left hand, grasp the grab handle that's on the rear of the door opening. See [Fig. 2.4](#).
3. Using your right hand, grasp the integral door lower grab handle.
4. Place your right foot on the bottom step, and step up to the upper step with your left foot.
5. Place your right foot on the top step, and step up.
6. Move your right hand to the upper grab handle on the windshield post.
7. Step into the cab with your left foot first.

Exiting the Passenger Side

Exit the cab from the passenger side as follows:

IMPORTANT: Do not attempt to exit the cab while carrying any items in your hands.

Vehicle Access

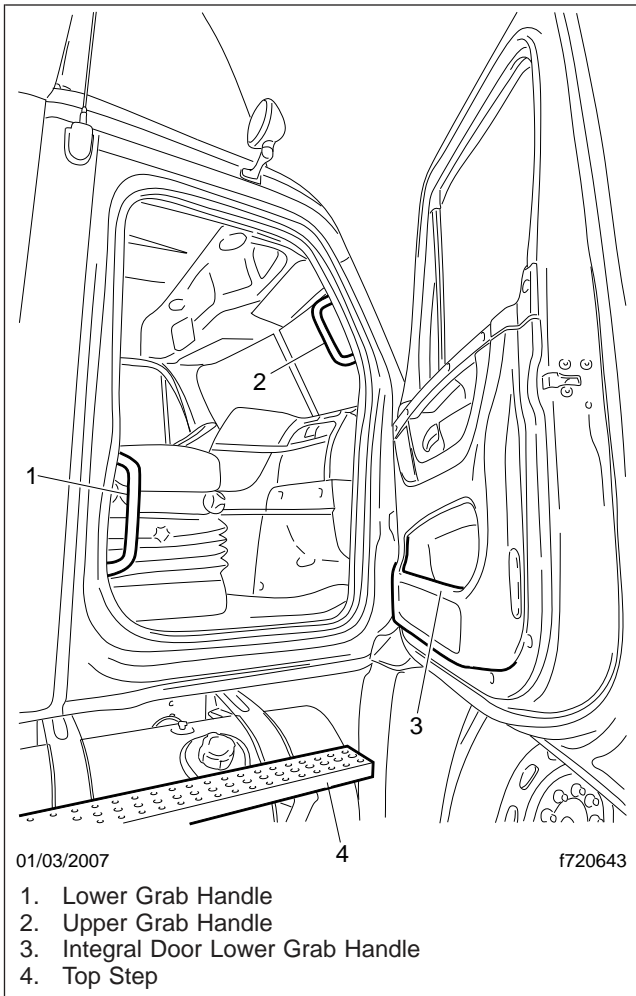

Fig. 2.4, Passenger-Side Steps and Grab Handles

1. Using both hands, grasp the grab handle that's on the windshield post, and place your right foot on the top step while standing up from the seat facing inward.
2. Place your left foot on the bottom step.
3. Move your left hand to the lower grab handle located at the rear edge of the door opening. See [Fig. 2.4](#).
4. Move your right hand to the integral door lower grab handle.
5. Step to the ground with your right foot first.

Cab-to-Sleeper Access

To open the sleeper access on vehicles with vinyl sleeper curtains, unzip the sleeper curtains. If desired, unsnap the curtains all the way around the sides and top, and remove the curtains.

To open the sleeper access on vehicles with velour sleeper curtains, unfasten the snaps at one side, then push the curtain to the opposite side.

Sleeper Door

The sleeper door ([Fig. 2.5](#), Ref. 1) is not intended for entry or exit. The door is intended only as a convenient means to stow or remove personal belongings in and from the sleeper area. To open the sleeper door from the inside, push down on the lever handle located inside the sleeper compartment aft of the door, or pull out on the upper lever located inside the cab door opening; see [Fig. 2.6](#). To open the sleeper door from outside, open the cab door, then pull out on the upper lever located inside the cab door opening. To close the door, pull on the strap attached to the inside of the door, or push it closed from the outside, until it latches.

IMPORTANT: The sleeper doors are two-stage latching. When closing the doors, ensure that they are completely latched to prevent wind noise and water intrusion.

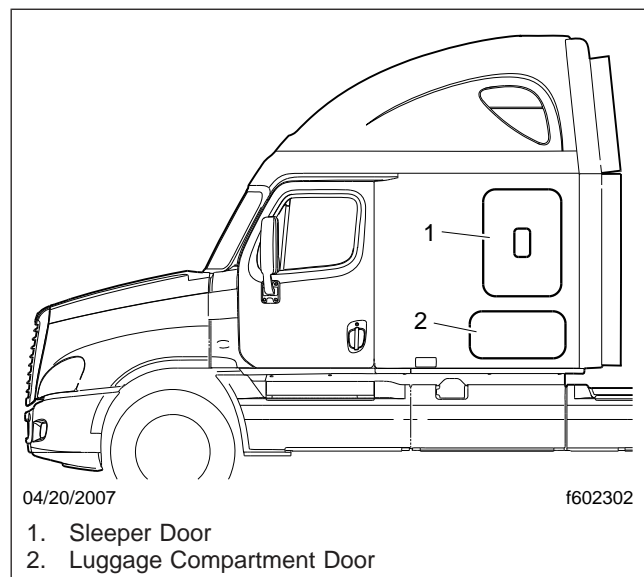

Fig. 2.5, Sleeper Doors

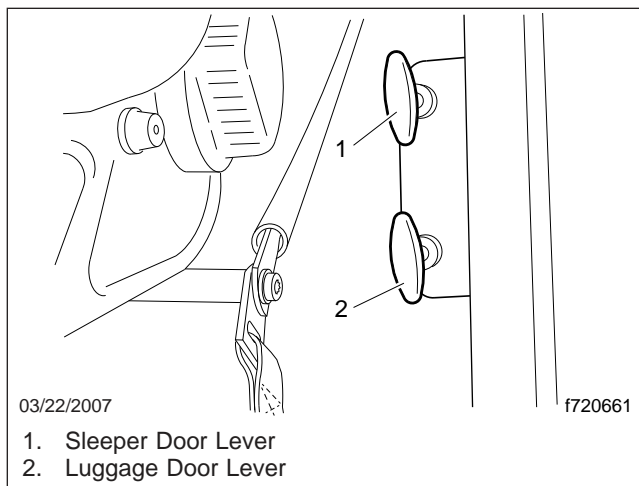

Fig. 2.6, Sleeper Door Levers

Sleeper Luggage Door

To open the sleeper luggage door, pull out on the lower lever located inside the cab door opening. See [Fig. 2.6](#). To close the door, push it closed until it latches.

Back-of-Cab Access



External surfaces of the exhaust system remain hot after the engine has been shut down. When accessing the back of the cab or sleeper, do not touch any part of the exhaust system, or severe burns could occur.

When trailer air and electrical connections cannot be reached conveniently from the ground, Federal Motor Carrier Safety Regulations require commercial carriers to provide back-of-cab access.

Optional grab handles are mounted either on both cab sidewalls, or on the left sidewall only. See [Fig. 2.7](#). Steps are mounted either on the fuel tank(s) or on metal brackets. When a deck plate is necessary, it is mounted across the top of the frame rails.

IMPORTANT: Climb onto, and down from, back-of-cab access facing in toward the vehicle, as you would on a ladder. Do not climb up or down facing out away from the vehicle.

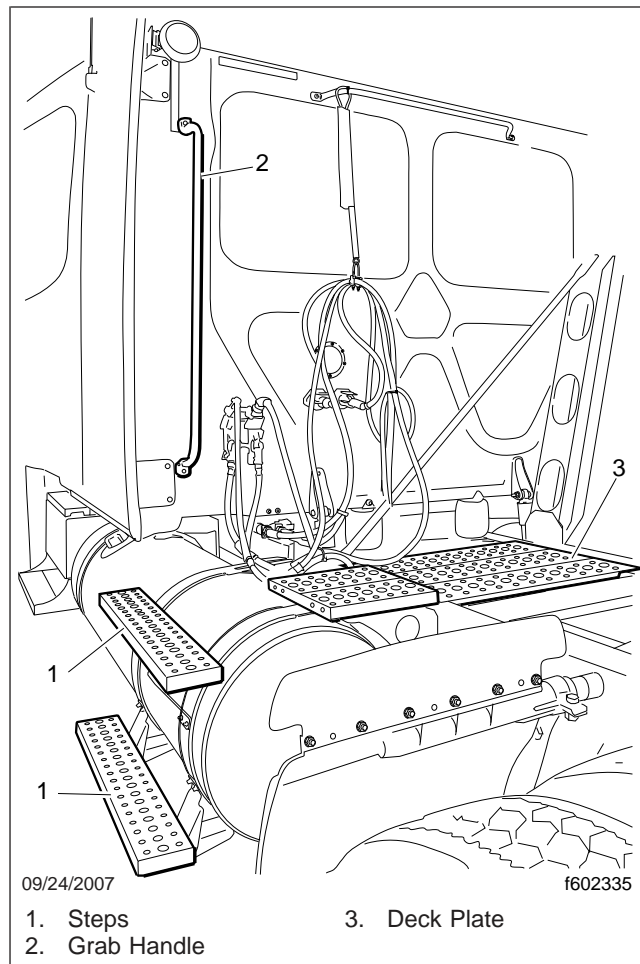

Fig. 2.7, Back-of-Cab Access



Wet or dirty shoe soles greatly increase the chance of slipping or falling. If your soles are wet or dirty, be especially careful when climbing onto, or leaving, the back-of-cab area.

Always maintain three-point contact with the back-of-cab access supports while entering and exiting the back-of-cab area. Three-point contact means both feet and one hand, or both hands and one foot, on the grab handles, steps, and deck plates. Other areas are not meant to support back-of-cab access, and grabbing or stepping in the wrong place could lead to a fall, and personal injury.

Vehicle Access

Be careful not to get hands or feet tangled in hoses or other back-of-cab equipment. Carelessness could cause a person to trip and fall, with possible injury.

Entering Back-of-Cab

When climbing onto the deck plate, do the following:

1. Grasp the sidewall grab handle with both hands. Reach up as far as is comfortable.
2. Place one foot on the bottom step and pull yourself up.
3. Place your other foot on the top step.
4. Move your lower hand to a higher position on the grab handle.
5. Step onto the deck plate.

Climbing Down from Back-of-Cab

To climb down from the back-of-cab area:

1. Grasp the sidewall grab handle with both hands.
2. Step one foot at a time onto the top step.
3. Move your upper hand to a lower position on the grab handle.
4. Move one foot to the bottom step.
5. Move your upper hand to a lower position on the grab handle.
6. Step to the ground with your upper foot first.

Hood Opening and Closing

A grab handle at the front of the hood provides a hand-hold for hood tilting. Two tilt-assist struts help to tilt the hood open, and to return it to the operating position. A damper controls the closing rate of the hood and hood straps prevent the hood from over-travel. In the operating position, the hood is secured by a hold-down latch on each side of the hood.

To Tilt the Hood

1. Apply the parking brakes.
2. Release both hood hold-down latches by pulling the ends outward.

CAUTION

Do not let the hood free-fall to the full-open position. To do so could cause damage to the hood or hood straps.

3. Using the bumper step and grab handle, slowly tilt the hood until the straps support it. See [Fig. 2.8](#).

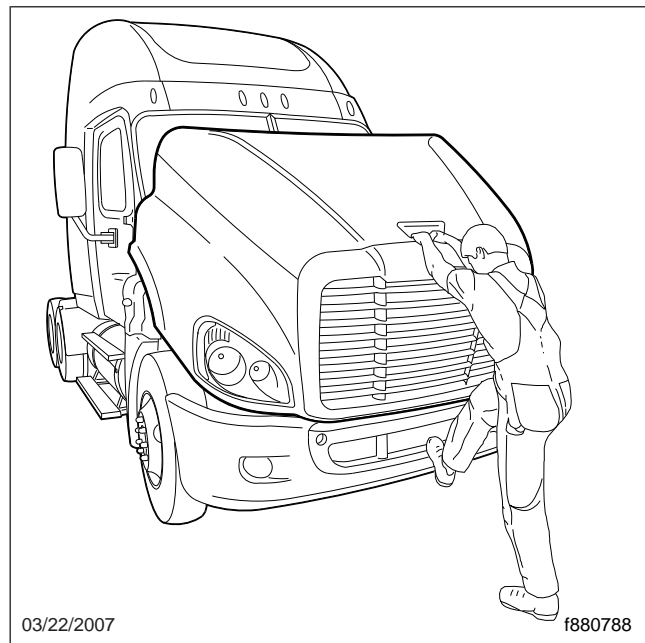

Fig. 2.8, Hood Tilting

To Return the Hood

1. Grasp the grab handle, and lift the hood a just-over-center position.
2. As the hood goes over center, the hood damper controls the rate of descent to the operating position.
3. Make sure the hood is flush with the cowl, then secure the hood by engaging both hood hold-down latches.

IMPORTANT: Make sure that both hold-down latches are fully engaged before operating the vehicle.

3

Electrical System

| | |
|--|-----|
| Electrical Power Distribution | 3.1 |
| Emergency Power Supply | 3.3 |
| Progressive Low Voltage Disconnect | 3.4 |

Electrical System

Electrical Power Distribution

Electrical power distribution provides battery power to the electrical and electronic systems. See [Fig. 3.1](#) for power distribution component locations.

The following components make up the power distribution system:

- MEGA Fuse Junction Block (MFJB), EPA07 only
- Powertrain Power Distribution Module (PT-PDM)
- Powernet Distribution Box (PNDB), EPA10 and newer
- Cab Load Disconnect Switch
- Auxiliary PDM

MEGA Fuse Junction Block, EPA07

On EPA07 vehicles, the MFJB distributes battery power to the alternator, SAM cab, SAM chassis, and powertrain PDM. Battery power may also be routed to an inverter and a trailer PDM. The MFJB houses up to five MEGA fuses, and is located on the left frame rail in front of the batteries. See [Fig. 3.2](#).

Powernet Distribution Box, EPA10 and Newer

The PNDB distributes battery power to the SAM cab, SAM chassis, powertrain PDM, and other keep-alive circuits.

The PNDB is mounted in the engine compartment on the frontwall near the steering column. The label on the PNDB fuse cover identifies typical circuits. See [Fig. 3.3](#).

Power Distribution Modules

Powertrain PDM

The powertrain PDM contains fuses and relays that provide battery and ignition power to the engine, aftertreatment device, transmission, and other powertrain-related circuits. It is mounted in the engine compartment, above the driver-side inner fender.

Auxiliary PDM

The optional auxiliary PDM is used when additional circuit protection is needed for optional features. For example, if a beacon light is added to the Cascadia, it may require an auxiliary PDM. The auxiliary PDM may contain fuses and relays for these devices. It is mounted in the cab, behind the doghouse cover.

Trailer PDM

The optional trailer PDM, mounted on the frame rail, is used to supply trailer power to the chassis-mounted trailer receptacles. The SAM chassis supplies control signals to the relays in the trailer PDM.

SAM Cab

The SAM cab is located behind the glove box inside the vehicle cab. See [Fig. 3.4](#). The SAM cab contains fuses and relays in addition to solid state circuit protection devices that will trip when a circuit is overloaded.

Refer to [Chapter 25](#) for fuse and relay locations.

SAM Chassis

The SAM Chassis is located in the engine compartment on the driver-side frontwall. See [Fig. 3.3](#). The SAM chassis contains fuses and relays in addition to solid state circuit protection devices that will trip when a circuit is overloaded.

Refer to [Chapter 25](#) for fuse and relay locations.

Circuit Protection Features

The SAM chassis and SAM cab may be equipped with self-resetting circuit breakers instead of fuses. Self-resetting circuit breakers are tripped when they reach 170°F (77°C), then self-reset once the temperature drops sufficiently. When the circuit overload is removed, this circuit protection will self-reset. Some of these circuits require the ignition switch to be cycled off then back on again for the self-reset to occur.

Some ECU's are equipped with a self-resetting circuit breaker removal tool.



Always wear heat-protective gloves when handling a self-resetting circuit breakers, which can

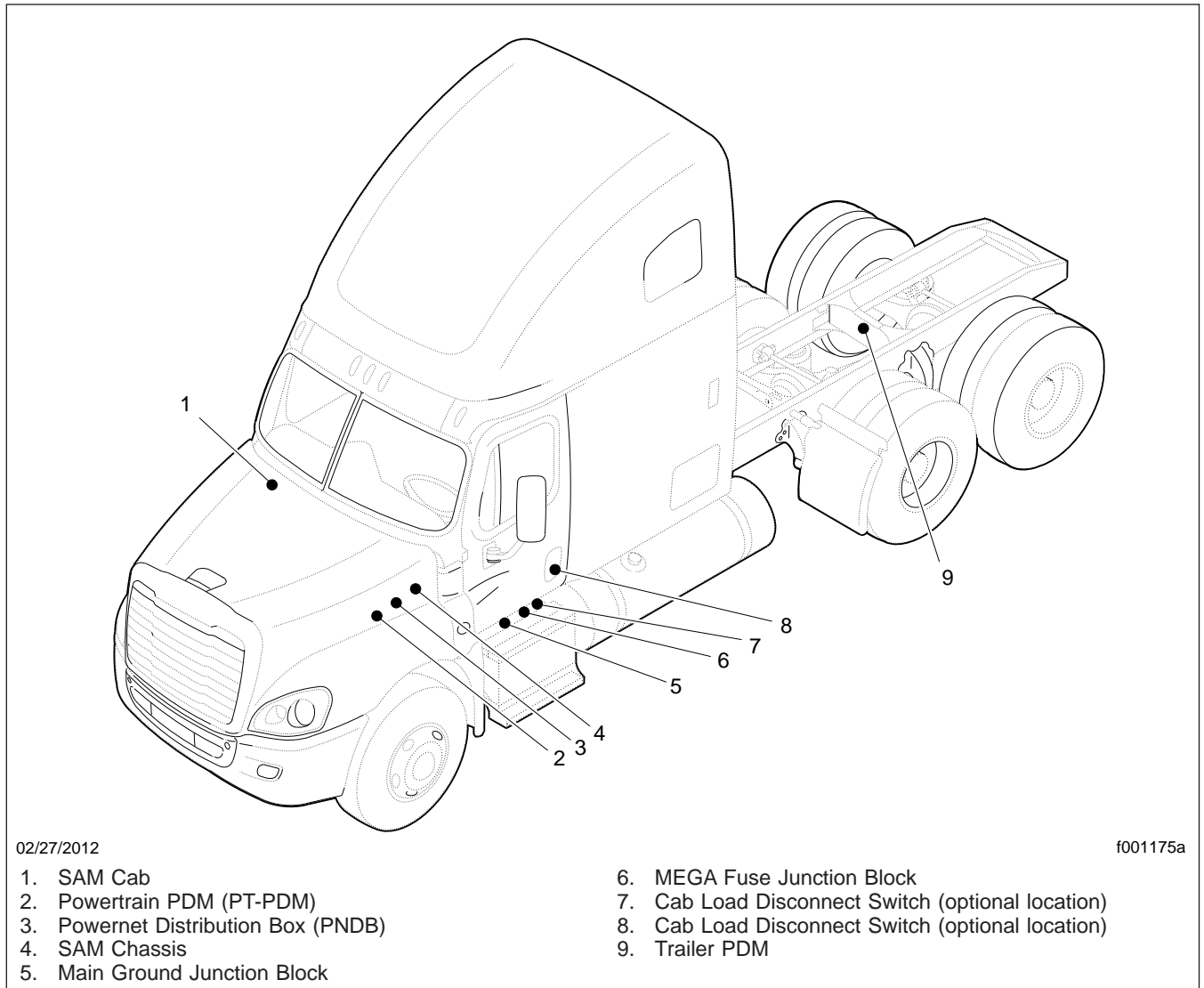

Fig. 3.1, Component Locations

reach extremely high temperatures. Failure to use appropriate heat protection can lead to serious injury.

NOTICE

Self-resetting circuit breakers can be permanently damaged if improperly handled. Use the guidelines below to handle them safely.

- Disconnect the batteries before removing a self-resetting circuit breaker.

- Use a circuit breaker removal tool to remove a self-resetting circuit breaker. See [Fig. 3.5](#). Use of any other tool, including pliers, may damage the circuit breaker.
- Never attempt to probe a self-resetting circuit breaker while installed on the SAM Cab or SAM Chassis. Remove the circuit breaker first, or use a non-contact infrared thermometer to measure temperature.

Electrical System

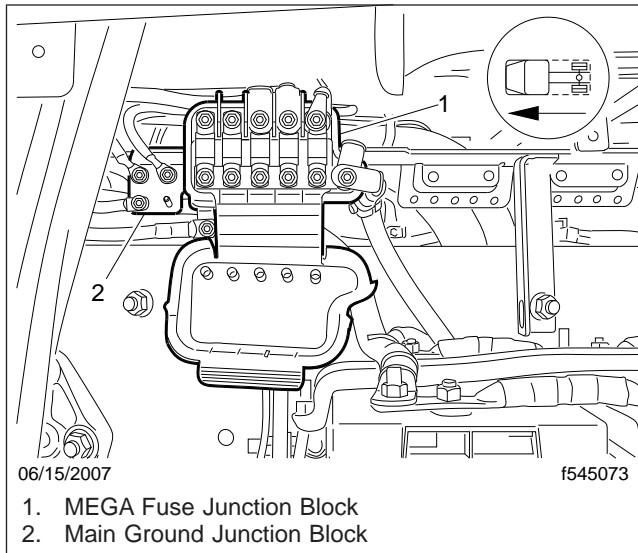

Fig. 3.2, EPA07 MEGA Fuse Junction Block

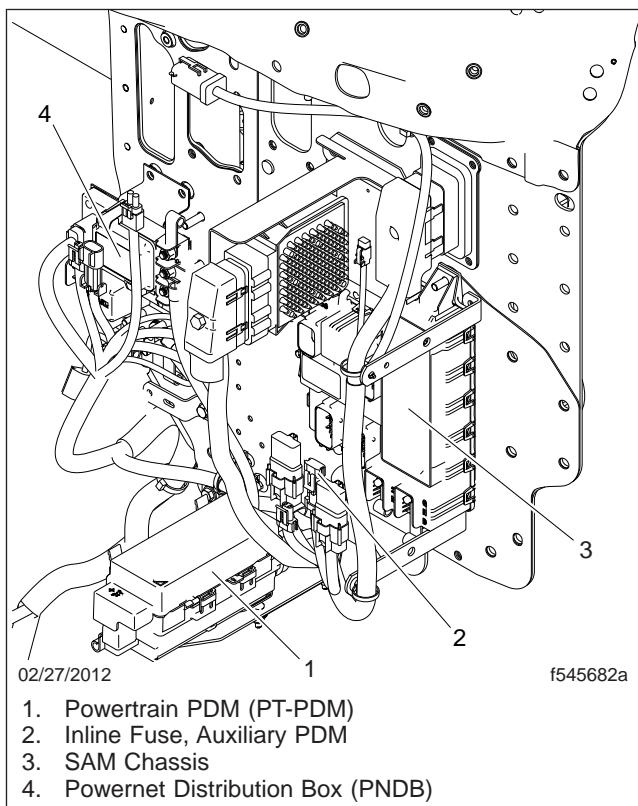

Fig. 3.3, Engine Compartment Power Distribution Components

Cab Load Disconnect Switch

WARNING

Turning the cab load disconnect switch (CLDS) to the off position does not disconnect the connection between the battery and the starter. To work on the vehicle safely, the negative leads must be disconnected from the battery.

IMPORTANT: The ignition should be turned off before turning the CLDS to on or off.

The CLDS is used to avoid excessive draw on the battery when the vehicle is parked for an extended period of time by disconnecting (or opening) the connection between the battery and the most of the vehicle electrical system.

The CLDS may be mounted:

- inside the cab on the outboard side of the driver's seat;
- at the battery box;
- outboard on the left frame rail.

See Fig. 3.6 for an EPA07 CLDS; see Fig. 3.7 for an EPA10 and newer switch.

If the CLDS is turned to the off position while the vehicle is running, the emergency power system will activate. The powertrain PDM will receive power from the emergency power feed, but the batteries will not be charging. See the **Emergency Power Supply** heading below for details.

Emergency Power Supply

The Cascadia electrical system has an emergency power circuit that supplies battery power for exterior lighting. This assists vehicle visibility in the event a MEGA fuse is open circuit. The emergency power circuit is live even when the CLDS is turned off.

The emergency power supply feature allows for the vehicle to be driven off the highway and for the exterior lighting to remain on in the event of a SAM Cab or SAM Chassis failure. The emergency power supply will cause certain exterior lamps to flash (depending on if it is the SAM Cab or SAM Chassis that failed), indicating that the vehicle is disabled.

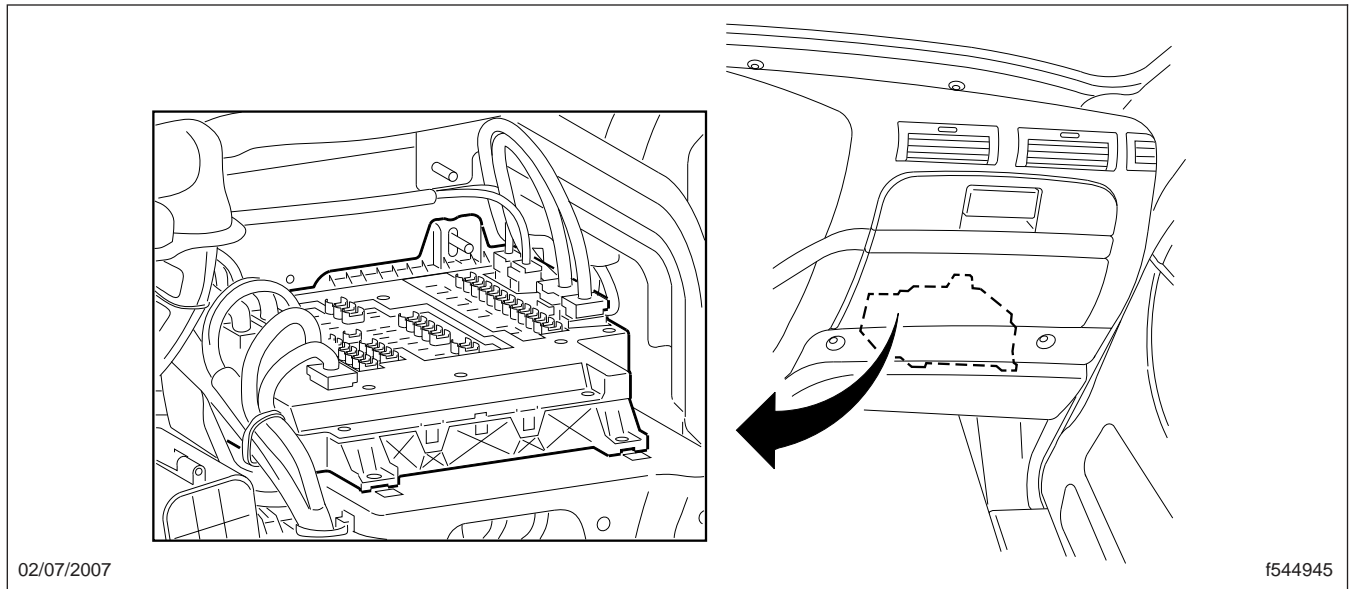

02/07/2007

f544945

Fig. 3.4, SAM Cab Location

SAM Cab Fault

If the emergency power supply system activates, do not shut down the engine until the vehicle is in a safe position to do so. It will not be able to be restarted until the problem is corrected. If emergency power mode is due to a SAM Cab fault, the gauges will become unresponsive but the engine will remain running until it is turned off.

When the ignition is in the ON position, the emergency power supply will cause the following lamps to flash:

- dash panel lights
- clearance lights
- front marker lights
- side marker lights
- trailer taillights
- rear stop lights

SAM Chassis Fault

The engine may be able to be restarted when the SAM Chassis fails. When the ignition is in the ON position, the emergency power supply will cause the following lamps to flash:

- dash panel lights

- identification lights
- front marker lights
- turn-signal indicators in the ICU (alternately)
- side marker lights
- rear turn-signal lights
- trailer taillights

If the ignition switch is turned ON while the load disconnect switch is in the OFF position, the emergency power supply feature will activate the following lamps:

- clearance lights (flashing)
- side marker lamps (flashing)
- low beam headlights

Progressive Low Voltage Disconnect

The progressive low voltage disconnect (PLVD) feature protects the batteries from excessive discharge by disconnecting certain circuits from battery power supply. This allows the batteries to maintain acceptable charge to restart the vehicle.

When battery voltage drops below a predetermined value, loads designated as comfort loads (priority

Electrical System

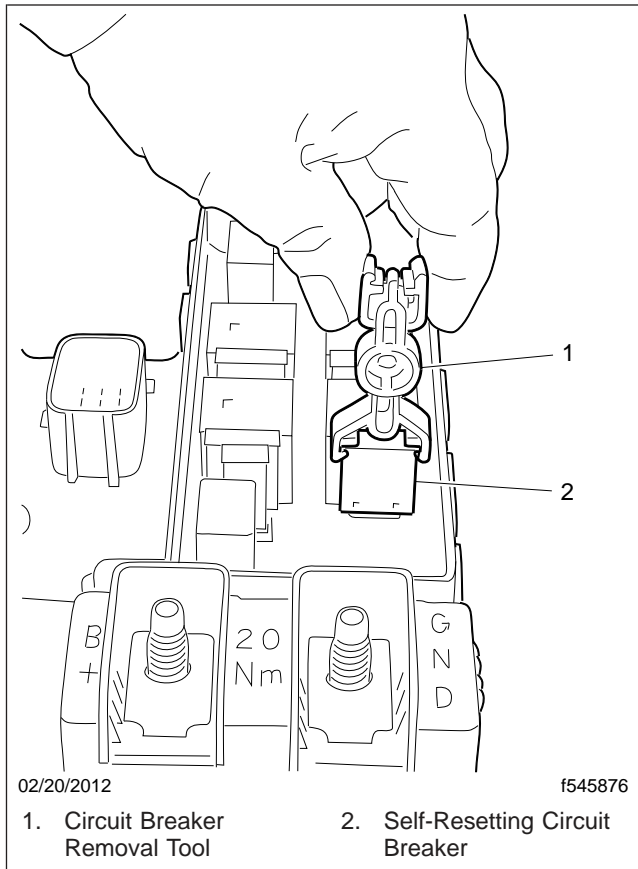

Fig. 3.5, Self-Resetting Circuit Breaker Removal

level I) are shut down first. Then loads designated as house loads (priority level II) are shut down. If necessary, basic loads (priority level III) are shut down last.

PLVD allows the driver to continue using critical loads, while noncritical loads are temporarily unavailable. Calculations for disconnecting loads are based on battery voltage, ignition switch status, and engine rpm. Also, a time delay is implemented for the shutdown and reactivation of loads to avoid unnecessary cycling of loads when battery voltage is close to shutdown thresholds.

One minute before the comfort loads or house loads are shut down, the alarm in the instrument cluster

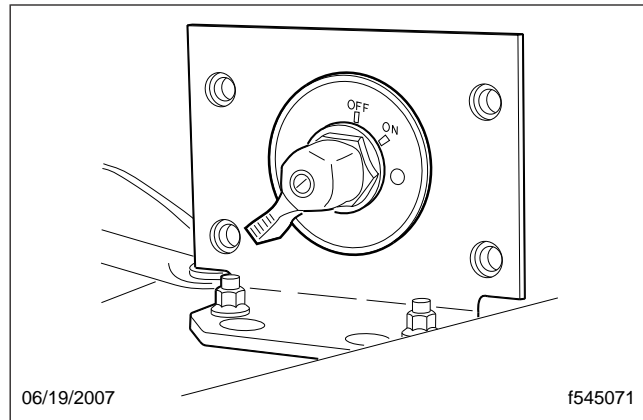

Fig. 3.6, Cab Load Disconnect Switch, EPA07

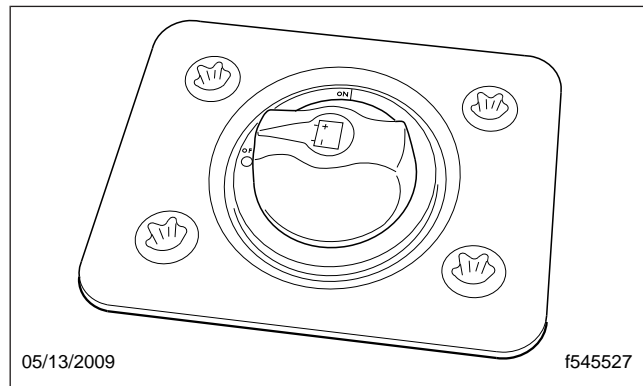

Fig. 3.7, Cab Load Disconnect Switch, EPA10 and Newer

beeps. No alarm sounds before basic loads are shut down.

If the interior lights have been shut down by PLVD, pressing one of the interior light switches (if equipped) brings the interior lights back on.

See [Table 3.1](#) for the type of loads shut down under specific conditions.

See [Table 3.2](#) for the loads that are designated comfort, house, and basic load status.

| Type of Loads Shut Down Under Specific Conditions | | | |
|---|---|--|--|
| Key Switch Position | Engine On, Voltage less than 12.5 Volts | Engine Off, Voltage less than 12.3 Volts | Engine Off, Voltage less than 12.1 Volts |
| Off | N/A | Priority level I, II loads | Priority level I, II, and III loads |
| Accessory | N/A | Priority Level I loads | Priority level I, II loads |

Electrical System

| Type of Loads Shut Down Under Specific Conditions | | | |
|---|---|--|--|
| Key Switch Position | Engine On, Voltage less than 12.5 Volts | Engine Off, Voltage less than 12.3 Volts | Engine Off, Voltage less than 12.1 Volts |
| On | Priority level I loads | Priority Level I loads | Priority level I, II loads |
| Start | N/A | N/A | N/A |

Table 3.1, Type of Loads Shut Down Under Specific Conditions

| Designated Loads | |
|------------------------------------|--|
| Type of Load | Function |
| Priority Level I | 12V power receptacle 6 (sleeper, refrigerator) |
| | Amplifier power, accessory |
| | General sleeper light |
| | Foot well light |
| | Reading light 1 (dimmer/theater) |
| | Reading light 2 (dimmer/theater) |
| | Rear baggage compartment light |
| | 12V power receptacle 5 (sleeper, cigar), battery |
| | Auxiliary circulation fan-sleeper, battery |
| | 12V power receptacle 4 (sleeper, cigar), battery |
| | Reading light 4 (switched locally), battery |
| Priority Level II | Heated seats, ignition* |
| | Sleeper HVAC controller, accessory* |
| | Cabin HVAC controller, accessory* |
| | Radio, accessory (clamp 15R) |
| | Power feed spare output I, battery |
| | Power feed spare output III, battery |
| | Mirror heating, passenger* |
| | Mirror heating, driver* |
| | Power feed spare output IV, battery |
| | Power feed spare output II, battery |
| | Fuel/water separator heater element, ignition* |
| | Air dryer (pneumatic, electrically heated), accessory* |
| | Auxiliary circulation fan-windshield, accessory* |
| | Accessory heater power |
| | Utility light |
| | Utility light |
| | Dome light rear |
| | Area lighting (lower bunk and sleeper work surface), battery |
| | Dome light cab, battery |
| | Overhead compartment lights, battery |
| | 12V power receptacle 3 (sleeper, cigar), battery |
| Stand-alone HVAC, battery | |
| Advertising light, accessory* | |
| Dome light passenger | |
| Dome light driver/forward overhead | |

Electrical System

| Designated Loads | |
|--------------------|---|
| Type of Load | Function |
| Priority Level III | CB radio, battery† |
| | Fleet management system, battery† |
| | Trailer power, battery or ignition |
| | 12V power receptacle 2 (dash, phone), battery |
| | 12V power receptacle 1 (dash, cigar), battery |

* When the vehicle has Optimized Idle, these functions will not operate with the ignition switch in the accessory position. Optimized Idle may also turn these functions off to reduce stress on the batteries. Refer to the Optimized Idle section in [Chapter 11](#) for more information.

† May or may not shut down depending on how an additional parameter is set at the factory or dealership.

Table 3.2, Load Designation

4

Instruments

| | |
|-------------------------------------|------|
| Instrumentation Control Units | 4.1 |
| Warning and Indicator Lights | 4.3 |
| Instruments | 4.7 |
| Driver Message Center | 4.11 |
| Overhead Instrument Panel | 4.24 |

Instruments

Instrumentation Control Units

The instrumentation control unit (ICU) provides the driver with engine and vehicle information. It is comprised of standard and optional gauges, an audible warning, a driver message center, and a lightbar containing warning and indicator lamps (also known as telltales). Warning and indicator lamps illuminate in red (danger), amber (caution), green (status advisory), or blue (high-beam headlights active).

Cascadia vehicles are equipped with an ICU3, ICU4, ICU4M, or ICU4Me. See [Fig. 4.1](#), [Fig. 4.2](#), and [Fig. 4.3](#) for typical ICU layouts.

The following headings in this chapter provide additional information and operating instructions for ICU components:

- "Warning and Indicator Lights"
- "Instruments"

- "Driver Message Center"

Ignition Sequence

When the ignition is turned on, the ICU runs a self-check. See [Fig. 4.4](#). Observing the ignition sequence is a good way to ensure the ICU is functioning properly.

IMPORTANT: Do not crank the engine until the ICU self-check is complete.

NOTE: Air gauges do not complete a sweep of their dials during the ignition sequence.

When the ignition is turned on, the following actions should occur:

- electronic gauges complete a full sweep of their dials

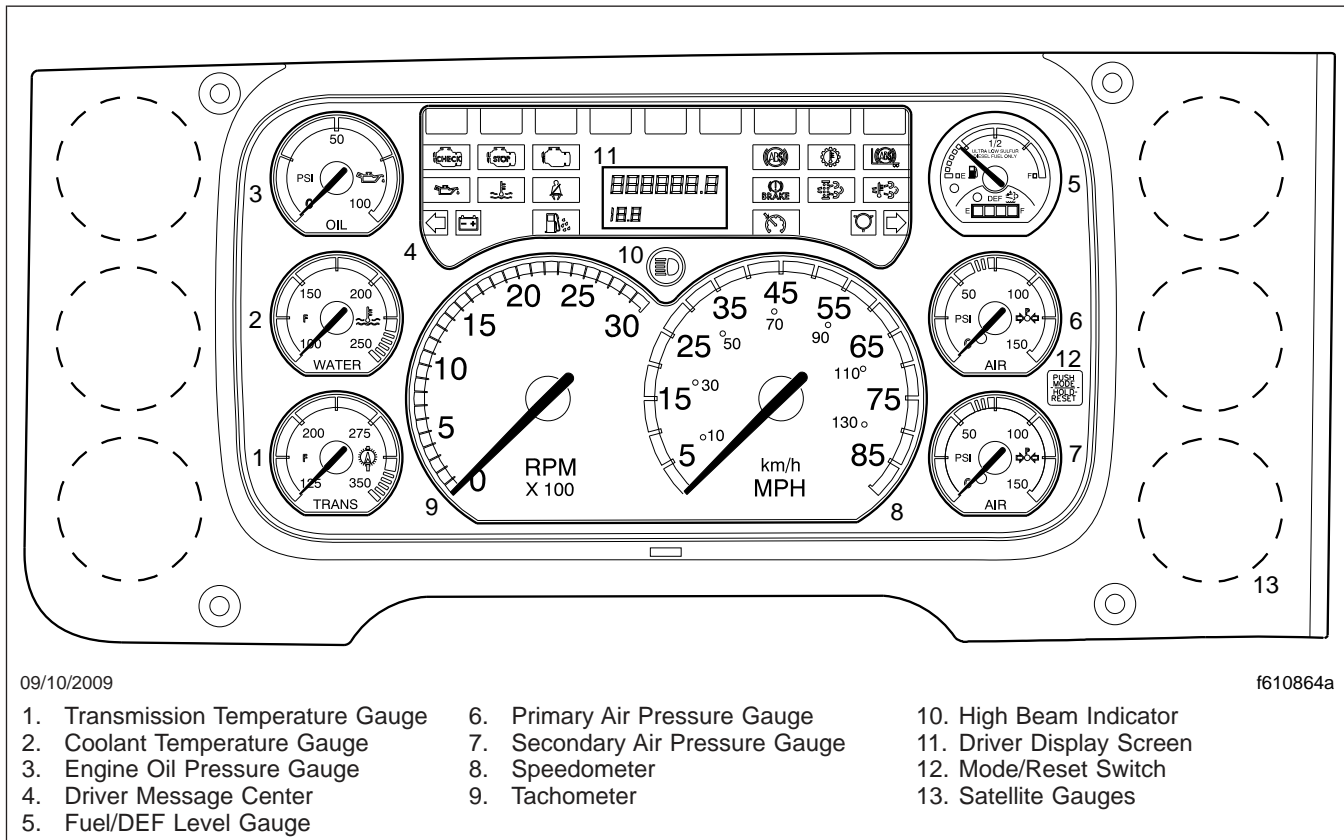

Fig. 4.1, ICU3 Instrument Cluster (EPA10 shown)

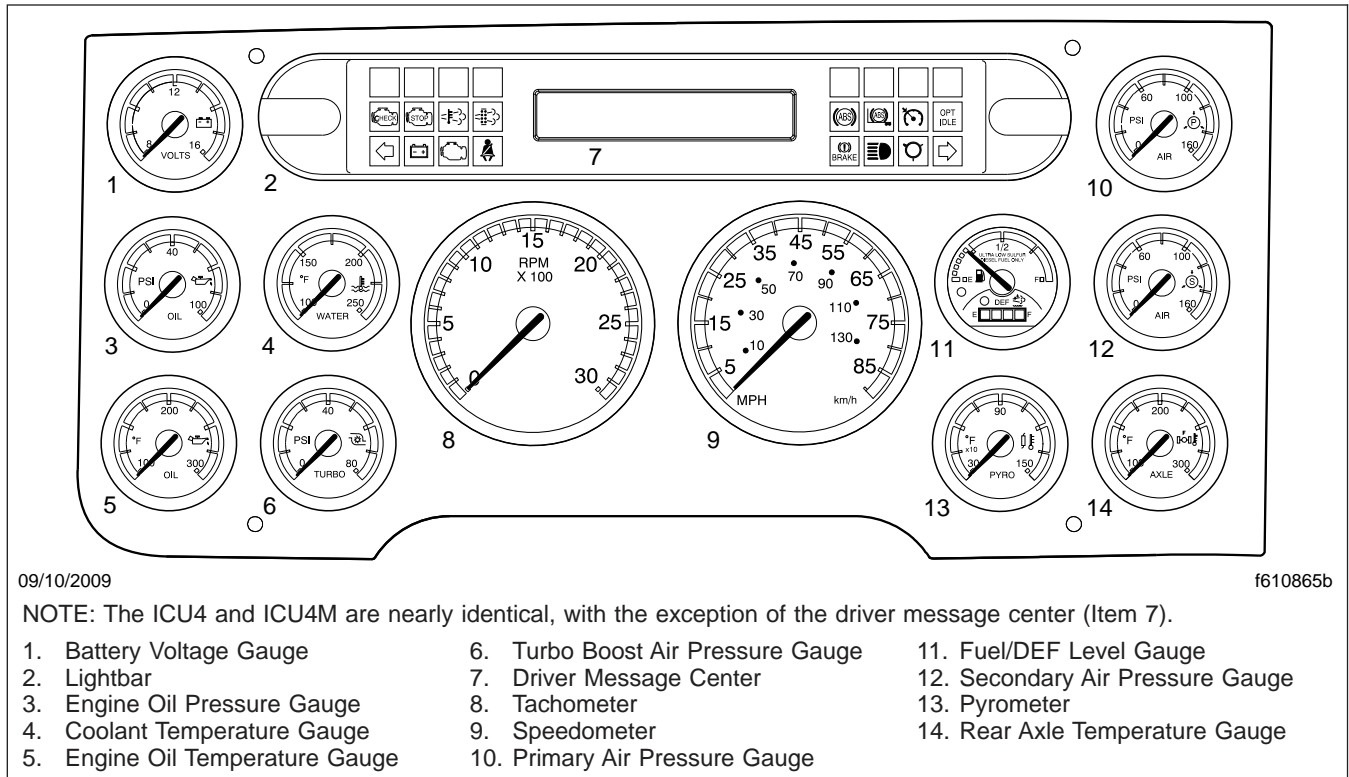

Fig. 4.2, ICU4M Instrument Cluster (EPA10 shown)

- warning and indicator lamps illuminate, then are extinguished
- audible alert sounds for approximately four seconds or until sufficient air pressure builds up in the primary and secondary air systems
- DEF level indicator illuminates all segments green, then turns them off one at a time before turning the leftmost segment amber and then red
- Freightliner logo displays on the ICU4Me driver message center for two seconds.
- software revision level of the ICU is displayed on the driver message center, followed by any active faults

IMPORTANT: If any red or amber warning and indicator lamps do not illuminate during the ICU self-check or do not go out after the self-check completes, take the action outlined in [Table 4.1](#), or take the vehicle to an authorized Freightliner service facility as soon as possible.

NOTE: If active faults are present, take the vehicle to an authorized Freightliner service facility as soon as possible.

If the ICU receives active fault codes, it displays them one after the other until the parking brake is released or the ignition is turned off. Once the parking brake is completely released, the ICU displays the odometer. If there are no active faults, the ICU displays the odometer after the self-check completes.

When the self-check is complete on an ICU4M, the fasten seat belt screen displays if the engine is off. If the engine is running, the idle hours screen displays.

Audible Alerts

An audible alert sounds during the ignition sequence and whenever one of the following conditions exists:

- Engine oil pressure falls below the minimum preset value.
- Coolant temperature rises above the maximum preset value.

Instruments



Fig. 4.3, ICU4Me Instrument Cluster

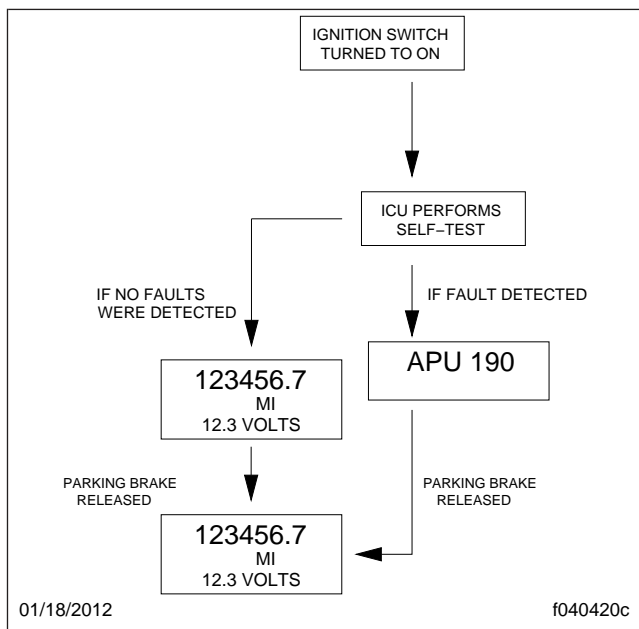

Fig. 4.4, ICU Ignition Sequence

- Air pressure falls below approximately 70 psi (483 kPa).
- Parking brake is set with the vehicle moving faster than two miles per hour.
- System voltage falls below 11.9 volts.
- Door is open or the headlights are on, with the parking brake off.
- Driver seat belt is not fastened with the parking brake off (optional).
- Outside temperature falls below 35°F (1.7°C) (optional).











Warning and Indicator Lights

The ICU lightbar has three or four rows of warning and indicator lights with icon symbols, depending on the ICU. The positions of the lights may vary for the different ICU's, but the telltales are standard for all applications. See [Table 4.1](#) for a listing of standard and commonly used warning and indicator lamps.











Warning and indicator lamps illuminate in red (danger), amber (caution), green (status advisory), or blue (high-beam headlights active).











IMPORTANT: Depending upon local jurisdictional emissions guidelines, vehicles and/or en-

gines that are domiciled outside of the U.S. and Canada may not be compliant with EPA07, EPA10, or GHG14 regulations. Noncompliant vehicles may not be equipped with all of the lamps shown in [Table 4.1](#).



| Common Warning and Indicator Lamps | | |
|---|--|-------|
| | Lamp Description | Color |
|  | STOP Engine* | Red |
| | Indicates a serious fault that requires engine shutdown immediately. The engine protection system will reduce the maximum engine torque and speed, and, if the condition does not improve, will shut down the engine within 30 to 60 seconds. Safely bring the vehicle to a stop on the side of the road and shut down the engine as soon as the red light is seen. If the engine shuts down while the vehicle is in a hazardous location, turn the key to the OFF position for a few seconds, then restart the engine and move the vehicle to a safer location. | |
|  | High Coolant Temperature | Red |
| | Indicates the coolant temperature is above the maximum allowable temperature. | |
|  | Low Air Pressure (EPA07) | Red |
| | Indicates air pressure in the primary or secondary reservoir has dropped below approximately 70 psi (483 kPa). | |
|  | Low Air Pressure (EPA10 and Newer) | Red |
| | Indicates air pressure in the primary or secondary reservoir has dropped below approximately 70 psi (483 kPa). | |
|  | Low Engine Oil Pressure | Red |
| | Indicates the engine oil pressure is below the minimum allowable pressure. | |
|  | Transmission Overheat | Red |
| | Indicates high transmission temperature. | |
|  | Transmission Fluid Level | Red |
| | Indicates low transmission fluid level. Safely bring the vehicle to a stop as soon as possible. | |
|  | Parking Brake (EPA07) | Red |
| | Indicates the parking brake is engaged, or hydraulic brake fluid pressure is low. An audible alert activates when the vehicle is moving over 2 mph (3 km/h) with the parking brake set. | |
|  | Parking Brake (EPA10 and Newer) | Red |
| | Indicates the parking brake is engaged. | |
|  | Low Battery Voltage | Red |
| | Indicates that battery voltage is 11.9 volts or less. | |

Instruments

| Common Warning and Indicator Lamps | | | |
|---|---|--|-------|
| Lamp Description | | Color | |
|  | Unfastened Seat Belt | Activates with an audible alert when the system detects that the parking brake is off and the driver seat belt is not fastened on some vehicles. On other vehicles, this lamp illuminates for 15 seconds when the ignition is first turned on. | Red |
|  | Check ECAS | Indicates Electronically Controlled Air Suspension (ECAS) active fault. | Red |
|  | CHECK Engine* | Indicates an engine condition (low oil pressure, low coolant level, high coolant temperature, high DPF soot level, or uncontrolled DPF regeneration) that requires correction. Correct the condition as soon as possible. If the condition worsens, the STOP engine lamp will illuminate. | Amber |
|  | High Exhaust System Temperature (HEST)* | Slow (10-second) flashing indicates a regeneration (regen) is in progress. IMPORTANT: When the HEST lamp is illuminated, do not park the vehicle near flammable material. | Amber |
|  | Diesel Particulate Filter (DPF) Status | Solid illumination indicates high exhaust temperatures at the outlet of the tail pipe when speed is below 5 mph (8 km/h). Solid illumination indicates a regen is required. Change to a more challenging duty cycle (such as highway driving) to raise exhaust temperatures for at least twenty minutes, or perform a parked regen. Blinking indicates that a parked regen is required immediately. An engine derate and shutdown will occur. | Amber |
|  | Malfunction Indicator Lamp (MIL) | Indicates an emissions-related fault. See the engine operation manual for details. | Amber |
|  | Vehicle ABS | Momentary illumination indicates the vehicle ABS is engaged. Solid illumination indicates a problem with the vehicle ABS. Repair the ABS immediately to ensure full braking capability. | Amber |
|  | Trailer ABS | Momentary illumination indicates the trailer ABS is engaged. Solid illumination indicates a problem with the trailer ABS. Repair the ABS immediately to ensure full braking capability. | Amber |
|  | No Charge | Indicates the alternator is not properly powering the electrical system. | Amber |
|  | Water in Fuel | Indicates the fuel may contain water. Drain any water collected in the fuel/water separators. | Amber |
|  | Fuel Filter Restriction | Indicates the fuel filter is clogged and requires service. | Amber |

| Common Warning and Indicator Lamps | | | |
|---|-------------------------------|---|-------|
| Lamp Description | | | Color |
|  | Optimized Idle | Indicates optimized idle is enabled. | Amber |
|  | Check Transmission | Indicates an undesirable transmission condition. | Amber |
|  | Wait To Start (EPA07/ EPA10) | Indicates that the system is preventing the starter from cranking. This can occur when the ignition switch is turned to START before the gauge sweep has completed, or if the starter has overheated. Turn the ignition switch back to ON, wait for the lamp to go out, then turn the ignition switch to START again. | Amber |
|  | Start Blocked (GHG14) | Indicates that the system is preventing the starter from cranking. This can occur when the ignition switch is turned to START before the gauge sweep has completed, or if the starter has overheated. NOTE: Illumination of the Start Blocked lamp does not indicate a problem with the starter. Turn the ignition switch back to ON, wait for the lamp to go out, then turn the ignition switch to START again. | Amber |
|  | Wheel Spin | Flashing indicates the ATC system is active, or the ATC button has been pressed to allow wheel slip. Solid illumination indicates a problem with the ATC system. Repair the ATC system immediately to ensure full braking capability. | Amber |
|  | Roll Stability | Momentary illumination indicates that a stability event has occurred. On vehicles that are also equipped with ATC, flashing indicates the ATC button has been pressed to allow wheel slip. | Amber |
|  | Hill Start Aid (HSA) Override | Indicates the HSA switch has been pressed to override the hill start assist feature. | Amber |
|  | Outside Normal Ride Height | Indicates the current rear suspension height is not at the normal ride height. This light will turn off once the vehicle returns to normal ride height. | Amber |
|  | Engine Brake | Indicates the engine brake is enabled. | Green |
|  | Left-Turn Signal | Flashing indicates the outside left-turn signal lights are activated. | Green |
|  | Right-Turn Signal | Flashing indicates the outside right-turn signal lights are activated. | Green |

Instruments

| Common Warning and Indicator Lamps | | |
|---|---|-------|
| Lamp Description | | Color |
|  | Cruise Control Indicates the cruise control is enabled. NOTE: The ICU4Me does not have a green cruise control telltale. | Green |
|  | High-Beam Headlights Indicates the high-beam headlights are on. | Blue |

* See Fig. 4.5 for an explanation of the aftertreatment system (ATS) warning indicators, and actions required to avoid further engine protection steps.

Table 4.1, Common Warning and Indicator Lamps

Engine Protection System



When the red STOP engine lamp illuminates, most engines are programmed to shut down automatically within 30 seconds. The driver must immediately move the vehicle to a safe location at the side of the road to prevent causing a hazardous situation that could cause bodily injury, property damage, or severe damage to the engine.

See Fig. 4.5 for an explanation of the aftertreatment system (ATS) warning indicators, and actions required to avoid further engine protection steps.

The STOP engine lamp illuminates when the engine protection system is activated in one of two ways. On some engines, the engine protection system will derate the engine, allowing it to run at lower rpm and slower vehicle speed. Drive the vehicle to a safe location or to a service facility.

IMPORTANT: Safely bring the vehicle to a stop on the side of the road and shut down the engine as soon as the red light is seen. If the engine shuts down while the vehicle is in a hazardous location, turn the key to the OFF position for a few seconds, then restart the engine and move the vehicle to a safer location.

On other engines, the engine protection system will shut down the engine. It will first derate the engine, then shut it down completely 30 to 60 seconds after the indicator illuminates (depending on the critical fault type) if the condition does not improve. Bring the vehicle to a stop on the side of the road before the engine shuts down.

Some vehicles may have a shutdown-override switch, which may be used to momentarily override the shutdown sequence. See Chapter 11 for detailed information regarding the shutdown process.

IMPORTANT: Do not attempt to restart the engine while the vehicle is moving. Bring the vehicle to a safe stop, then restart the engine.

To restart the engine, turn the ignition to OFF, leave it there a few seconds, then turn the ignition to START. The engine will run for a short period and shut down again if the condition does not improve.

Instruments

Standard instruments are present on every vehicle. They are listed here in alphabetical order to make the information easier to find.







Optional instruments, typically located on the auxiliary dash panel or right-hand control panel, are not found on every vehicle. They are listed here in alphabetical order, to make the information easier to find.

Air Intake Restriction Gauge

The air intake restriction gauge indicates the vacuum on the engine side of the air cleaner. On standard installations, it is mounted on the air intake duct in the engine compartment. As an option for easier viewing, the air intake restriction indicator (see Fig. 4.6) can be mounted on the dash, usually on the right-hand control panel.

NOTE: Rain or snow can wet the filter and cause a temporary high reading.

Air intake restriction vacuum is measured in inches of water (inH₂O). For vehicles equipped with a graduated indicator or a restriction gauge on the

| EXHAUST AFTERTREATMENT SYSTEM INFORMATION | | | | | |
|---|--|---|---|--|--|
| INDICATOR LAMP(S) |  (Solid) Level 1 |  (Flashing) Level 2 |  (Flashing) CHECK Level 3 |  STOP Level 4 |  WARNING  |
| Indicator Lamp Message(s) | Filter Regeneration Recommended. | Filter Regeneration Necessary | Parked Regeneration Required – Engine Derate | Service Regeneration Required. Engine Derate To Idle Only. | HEST (High Exhaust System Temperature) |
| Diesel Particulate Filter Condition | Filter is reaching capacity. | Filter is now reaching maximum capacity. | Filter has reached maximum capacity. | Filter has exceeded maximum capacity. | Flashing A regeneration is in progress. |
| Required Action | Bring vehicle to highway speeds to allow for an Automatic Regeneration or perform a Parked Regeneration. | To avoid engine derate, bring vehicle to highway speeds to allow for an Automatic Regeneration, or perform a Parked Regeneration as soon as possible. | Vehicle must be parked, and a Parked Regeneration must be performed. Engine will begin derate. | Vehicle must be parked, and a Service Regeneration must be performed. Check engine operator's manual for details. Engine will shut down. | Solid Exhaust components and exhaust gas are at high temperature. When stationary, keep away from people and flammable materials or vapors. |
| For a driver performed Parked Regeneration, vehicle must be equipped with a dash mounted Regeneration Switch. | | | | | |

02/20/2009

f080156

Fig. 4.5, ATS Warning Lamps

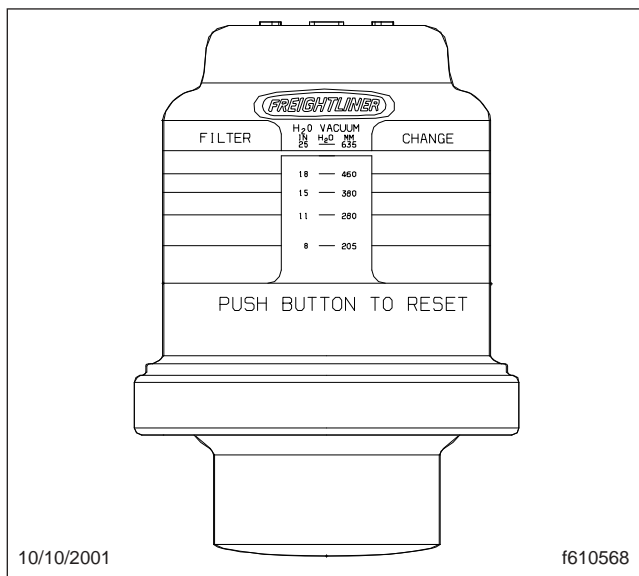

10/10/2001

f610568

Fig. 4.6, Air Intake Restriction Indicator

dash, check the gauge with the engine off. If the yellow signal stays locked in the red zone once the engine is shut down, or is at or above the values shown in [Table 4.2](#), the air cleaner element needs to be replaced.

Vehicles may be equipped with a go/no-go restriction indicator without graduations (see [Fig. 4.7](#)) instead of a graduated indicator.

| Air Intake Maximum Restriction Values (inH ₂ O) | | |
|--|-------------------|-------------------------|
| Engine Make | Pre-EPA07 Engines | EPA07 and Newer Engines |
| Cummins | 25 | 25 |
| Detroit | 20 | 22 |
| Mercedes-Benz | 22 | 22 |

Table 4.2, Air Intake Maximum Restriction Values

Application Air Pressure Gauge

An application air pressure gauge registers the air pressure being used to apply the brakes, and should be used for reference only. The gauge will not register air pressure until the foot brake pedal is depressed or the trailer hand brake is applied.

Instruments

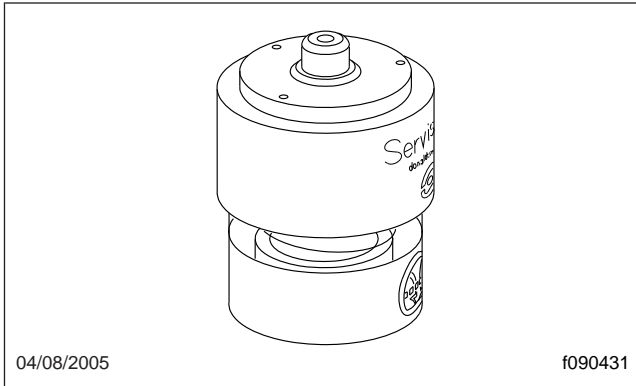

Fig. 4.7, Manual-Reset Air Restriction Indicator, Go/No-Go

Coolant Temperature Gauge

NOTICE

A sudden increase in coolant temperature may indicate engine or cooling system failure. Bring the vehicle to a safe stop and investigate the cause to prevent further damage. Do not operate the engine until the cause has been determined and corrected.

During normal engine operation, the coolant temperature gauge should read 175 to 195°F (79 to 91°C). If the temperature remains below 160°F (71°C), inspect the cooling system to determine the cause.

If coolant temperature rises above the maximum temperature listed in [Table 4.3](#), the CHECK engine lamp will illuminate. If the condition does not improve, the STOP engine lamp will also illuminate and an audible warning will sound. The engine will then derate or shut down, depending on the type of engine protection system installed.

| Maximum Coolant Temperature | |
|-----------------------------|----------------------|
| Engine Make | Temperature: °F (°C) |
| Cummins | 225 (107) |
| Detroit | 215 (101) |
| Mercedes-Benz | 221 (105) |

Table 4.3, Maximum Coolant Temperature

Drive Axle Oil Temperature Gauges

NOTICE

A sudden increase in oil temperature that is not caused by a load increase may indicate mechanical failure. Bring the vehicle to a safe stop and investigate the cause to prevent further damage. Do not operate the vehicle until the cause has been determined and corrected.

During normal operation, drive axle oil temperature gauges should read as follows:

- 160 to 220°F (71 to 104°C) for Detroit™ and Meritor™ drive axles
- 180 to 200°F (82 to 93°C) for Dana Spicer® drive axles

Under heavy loads, such as when climbing steep grades, temperatures that exceed the normal oil temperature range for a short period are not unusual. If the temperature returns to normal when the load decreases, there is no problem.

Engine Oil Pressure Gauge

NOTICE

A sudden decrease or absence of oil pressure may indicate mechanical failure. Bring the vehicle to a safe stop and investigate the cause to prevent further damage. Do not operate the engine until the cause has been determined and corrected.

The engine oil pressure gauge displays the current engine oil pressure. If engine oil pressure falls below the minimum levels shown in [Table 4.4](#), the CHECK engine lamp will illuminate. If the condition does not improve, the STOP engine lamp will also illuminate and an audible warning will sound. The engine will then derate or shut down, depending on the type of engine protection system installed.

| Minimum Oil Pressure* | | |
|-----------------------|-----------------------------|----------------------------|
| Engine Model | At Idle Speed: psi (kPa) | At Rated RPM: psi (kPa) |
| Cummins | 15 (103) | 35 (241) |
| Detroit | 14 (97) | 55 (350) |

| Minimum Oil Pressure* | | |
|-----------------------|-----------------------------|----------------------------|
| Engine Model | At Idle Speed: psi (kPa) | At Rated RPM: psi (kPa) |
| Mercedes-Benz | 7 (50) | 36 (250) |

* Oil pressures are given with the engine at operating temperature. With the engine cold, oil pressure may be higher. Individual engines may vary from the listed pressures; observe and record pressures when the engine is new to create a guide for checking engine condition.

Table 4.4, Minimum Engine Oil Pressure

Engine Oil Temperature Gauge

NOTICE

A sudden increase in oil temperature that is not caused by a load increase may indicate mechanical failure. Bring the vehicle to a safe stop and investigate the cause to prevent further damage. Do not operate the engine until the cause has been determined and corrected.

During normal operation, the optional engine oil temperature gauge should read:

- 200 to 260°F (93 to 126°C) for Detroit and Cummins engines
- 177 to 203°F (81 to 95°C) for Mercedes-Benz engines

Under heavy loads, such as when climbing steep grades, temperatures that exceed the normal oil temperature range for a short period are not unusual. If the temperature returns to normal when the load decreases, there is no problem.

Fuel Gauge, Pre-EPA10

The fuel gauge indicates the level of fuel in the fuel tank(s). A single fuel gauge is standard. If equipped with an optional second fuel tank, each fuel tank level is indicated on a separate gauge.

Fuel/Diesel Exhaust Fluid (DEF) Gauge, EPA10 and Newer

For engines that are EPA10-compliant or newer, the fuel and DEF levels are measured in a dual purpose fuel/DEF level gauge. See [Fig. 4.8](#).

The diesel fuel level is indicated at the top of the gauge, with a low-fuel warning lamp that illuminates amber when the diesel fuel level registers 1/8th of capacity.

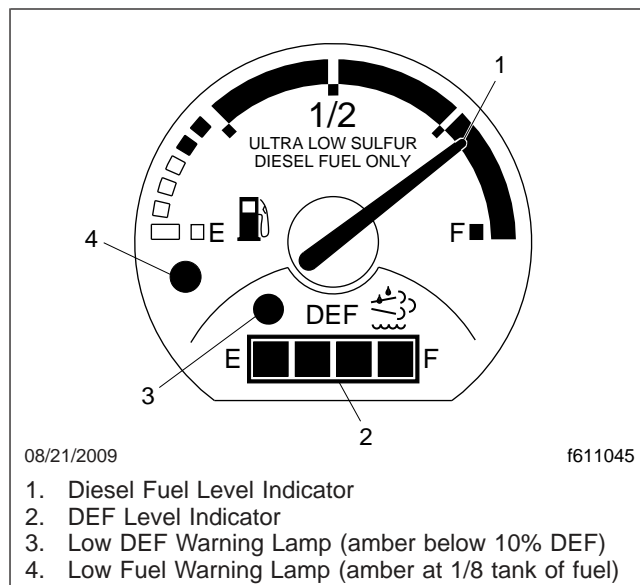

Fig. 4.8, Fuel/DEF Gauge, EPA10 and Newer

The DEF level is indicated in the lightbar on the lower portion of the gauge. There is a low DEF level warning lamp that illuminates amber when the DEF level reaches 10% of capacity. See [Chapter 12](#) for details of the DEF gauge functions.

Primary and Secondary Air Pressure Gauges

WARNING

If air pressure falls below minimum pressure, the braking ability of the vehicle will be limited. Slow the vehicle down and bring it to a gradual stop. Do not attempt to move the vehicle until air pressure has risen above the minimum level. Moving a vehicle without adequate braking power could cause an accident resulting in property damage, personal injury, or death.

Air pressure gauges register the pressure in the primary and secondary air systems. Normal pressure, with the engine running, is 100 to 120 psi (689 to 827 kPa) in both systems.

A low-air-pressure warning light and audible alert, connected to both the primary and secondary systems, activate when air pressure in either system drops below approximately 70 psi (483 kPa).

Instruments

When the engine is started, the warning light and audible warning remain on until air pressure in both systems exceeds minimum pressure.

Speedometer

Two speedometer options are available. The U.S. version of the speedometer registers speed in both miles per hour (mph) and kilometers per hour (km/h), with mph in larger numbers. The metric version of the speedometer face reverses this arrangement, with km/h in larger numbers.

Tachometer

The tachometer indicates engine speed in revolutions per minute (rpm) and serves as a guide for shifting the transmission and keeping the engine in the appropriate rpm range. For low idle and rated rpm, see the engine identification plate.

Transmission Fluid Temperature Gauge

The transmission fluid temperature gauge indicates the transmission lubricant operating temperature. Temperatures vary by application, but the transmission fluid temperature gauge reading should not exceed 250°F (121°C).

NOTICE

A sudden increase in transmission fluid temperature that is not caused by a load increase may indicate mechanical failure. Bring the vehicle to a safe stop and investigate the cause to prevent further damage. Do not operate the vehicle until the cause has been determined and corrected.

Under heavy loads, such as when climbing steep grades, temperatures that exceed the normal oil temperature range for a short period are not unusual. If the temperature returns to normal when the load decreases, there is no problem.

Turbocharger Boost Pressure Gauge

A turbocharger boost pressure gauge indicates the pressure in the intake manifold, in excess of atmospheric pressure, being created by the turbocharger.

Voltmeter

The voltmeter indicates the vehicle charging system voltage when the engine is running and the battery voltage when the engine is off. By monitoring the voltmeter, the driver can stay aware of potential battery charging problems and have them fixed before the batteries discharge enough to create starting difficulties. Cascadia vehicles are equipped with either a voltmeter gauge, or a digital voltmeter readout located on the bottom line of the dash message center.

The voltmeter will normally show approximately 13.7 to 14.1 volts when the engine is running. The voltage of a fully charged battery is 12.7 to 12.8 volts when the engine is off. Battery voltage under 12.0 volts is considered a low battery, and a completely discharged battery will produce only about 11.0 volts.

If the voltmeter shows an undercharged or overcharged condition for an extended period, have the charging system and batteries checked at an authorized Freightliner service facility.

On a vehicle equipped with a battery isolator system, the voltmeter measures the average voltage of all the batteries when the engine is running. When the engine is off, the voltmeter shows only the isolated battery voltage and does not indicate the voltage of the engine-starting batteries.

Driver Message Center

ICU3/ICU4

The driver message center is controlled using the mode/reset switch, located on the right side of the ICU, and the + and – buttons mounted in the right-hand pod of the steering wheel (**Fig. 4.9**). See **Fig. 4.1** and **Fig. 4.9**. Tap the mode/reset switch or the + switch to advance one screen; press and hold either switch to select a menu choice or reset the display. When the display resets, an audible chirp sounds.

Four driving screens are accessible when the parking brake is off. All screens and menus are accessible when the parking brake is on (parked screens).

Driving Screens

The following screens are available when the parking brake is off (when the vehicle is mobile) and no active fault codes are found. Use the + and – switches on the steering wheel, or the mode/reset switch, to

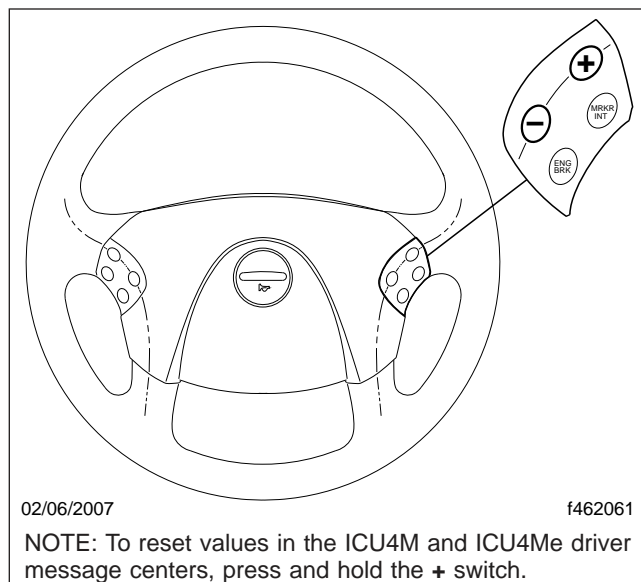

Fig. 4.9, Steering Wheel-Mounted Switches

scroll through the screens. To reset any values, press and hold the + switch or the mode/reset switch. The driving screens appear in the following order:

- i. Odometer
- ii. Trip distance
- iii. Trip hours
- iv. Outside temperature

Parked Screens/Menus

The following screens and menus are available when the parking brake is on (when the vehicle is parked) and no active fault codes are found. Use the + and - switches on the steering wheel, or the mode/reset switch, to scroll through the driving screens. To reset any values, press and hold the + switch or the mode/reset switch. See [Fig. 4.10](#). The parked screens appear in the following order:

- i. Odometer
- ii. Trip distance
- iii. Trip hours
- iv. Outside temperature
- v. Temperature alert
- vi. Diagnostics

- vii. Clear screen (on vehicles with less than 255 miles on the odometer)
- viii. Engine miles/hours
- ix. Setup

Temperature Alert

When the outside temperature drops to 35°F (1.7°C) or less, the ICU displays a caution text at one-second intervals for five seconds, and an audible alert sounds. Tap the + or - switch on the steering wheel, or the mode/reset switch, to acknowledge the message. The audible alert will not sound again unless the temperature cycles above 37°F (4°C) and back to 35°F (1.7°C) or less. This warning only occurs while the ignition is on and the parking brake is released.

The temperature alert message allows the driver to enable or disable the ambient temperature warning.

Press and hold the mode/reset switch to toggle between on and off. Release the mode/reset switch, then tap it to select the displayed choice.

Diagnostics

When the DIAG screen is displayed, press and hold the mode/reset switch to access the various diagnostic screens. See [Fig. 4.11](#) for a diagram of the diagnostic screens.

The diagnostic screens are used by trained technicians to retrieve fault codes and other diagnostic information pertaining to the vehicle. If active fault codes display during start-up or at any other time, make a note of the fault code and take the vehicle to an authorized Freightliner service facility

If fault codes are displayed, press and hold the mode/reset switch to view the next fault code until reaching the DIAG screen.

Engine Miles/Hours

When the engine miles/hours screen is displayed, press and hold the mode/reset switch to access the engines screen submenu. See [Fig. 4.11](#) for a diagram of the engine screens.

Instruments

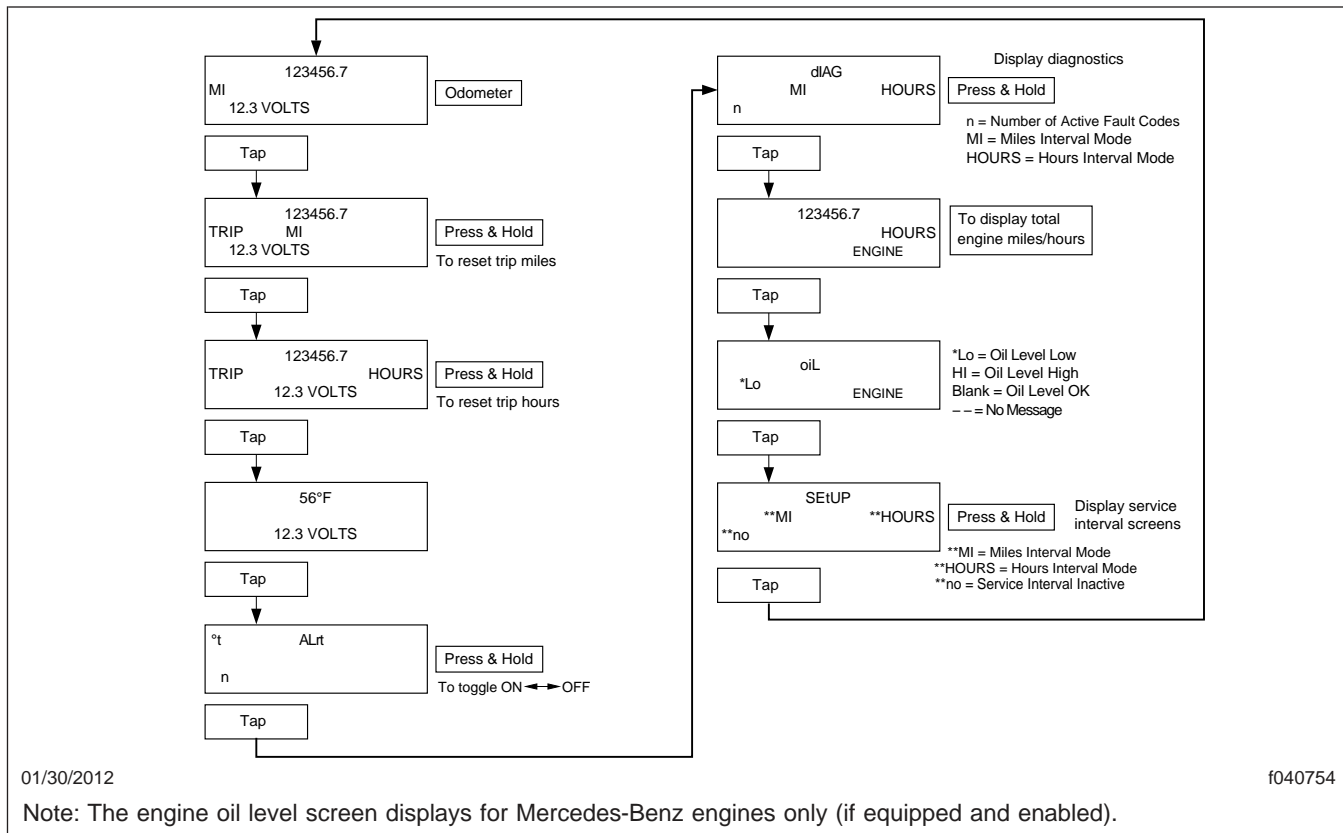

Fig. 4.10, ICU3 Parked Screens

Setup

The setup menu allows the driver to manage ICU parameters. The setup screen submenu allows the driver to enable and change service intervals. See Fig. 4.12.

If service intervals are enabled and service distance or time has been exceeded, the text SERVICE HOUR/MI (KM) will display at start-up to indicate vehicle service is required.

For each parameter, press and hold the mode/reset switch to navigate to the parameter change screen. In each change screen, tap the mode/reset switch to toggle between options.

Use the last screen in the setup menu, **RESET EE**, to reset the parameters the ICU learns back to the default settings. Press and hold the mode/reset switch to reset the following learned parameters:

- automated transmission display

- seat belt switch learning
- engine oil level
- other electronic devices that have been removed from the vehicle (e.g. Qualcomm)

ICU4M

Functions

ICU4M settings and the driver message center are controlled with the + and – switches and the MY INFO switch, mounted on the dash. See Fig. 4.13. Tap the MY INFO switch to drill down from each main screen to the submenus contained within it. Use the + and – switches to scroll through screens and select options. Tap the MY INFO switch again to exit each change screen.

With the parking brake off, only the odometer and alert messages can be displayed. Park the vehicle and set the parking brake to access the parked screens and menus.

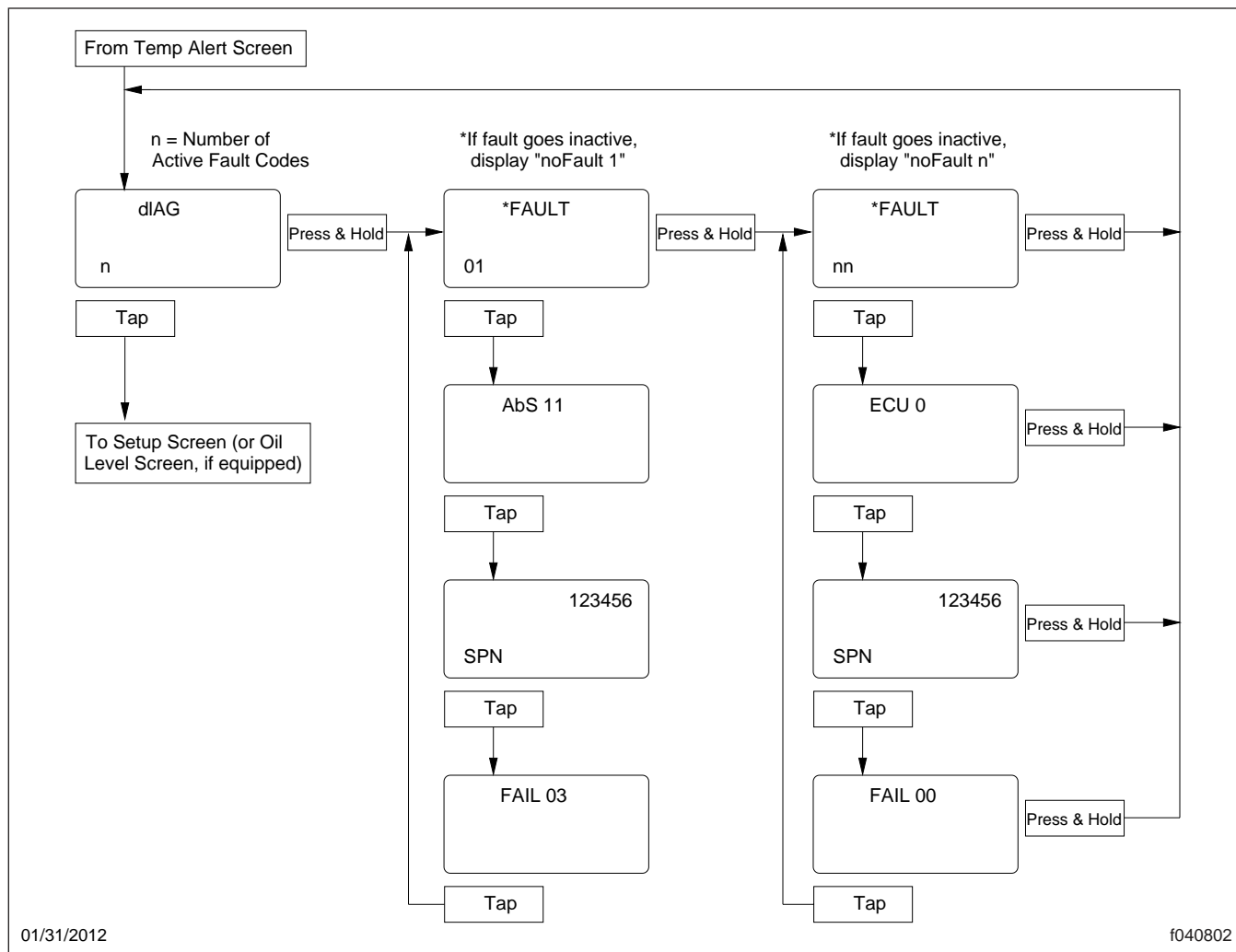

Fig. 4.11, ICU4 Diagnostic Screens

Alert Messages

The driver message center displays alert messages when certain conditions occur. They are warnings, cautions, or other messages that require the driver's attention, but not all of them are critical to the operation of the vehicle.

NOTE: If there is more than one alert message to display, tap the + switch or the MY INFO switch to access the next message, and so on, until all messages have been viewed.

More important messages take priority over less important messages. The order of priority is:

1. parking brake set (with the vehicle moving)
2. parking brake off (with the door open)
3. low oil pressure or high coolant temperature
4. hard brake warnings (if equipped with roll stability advisor)
5. low battery voltage
6. ambient temperature below 35°F (1.7°C)
7. turn signal on
8. incoming instant or Qualcomm messages
9. service warnings

Instruments

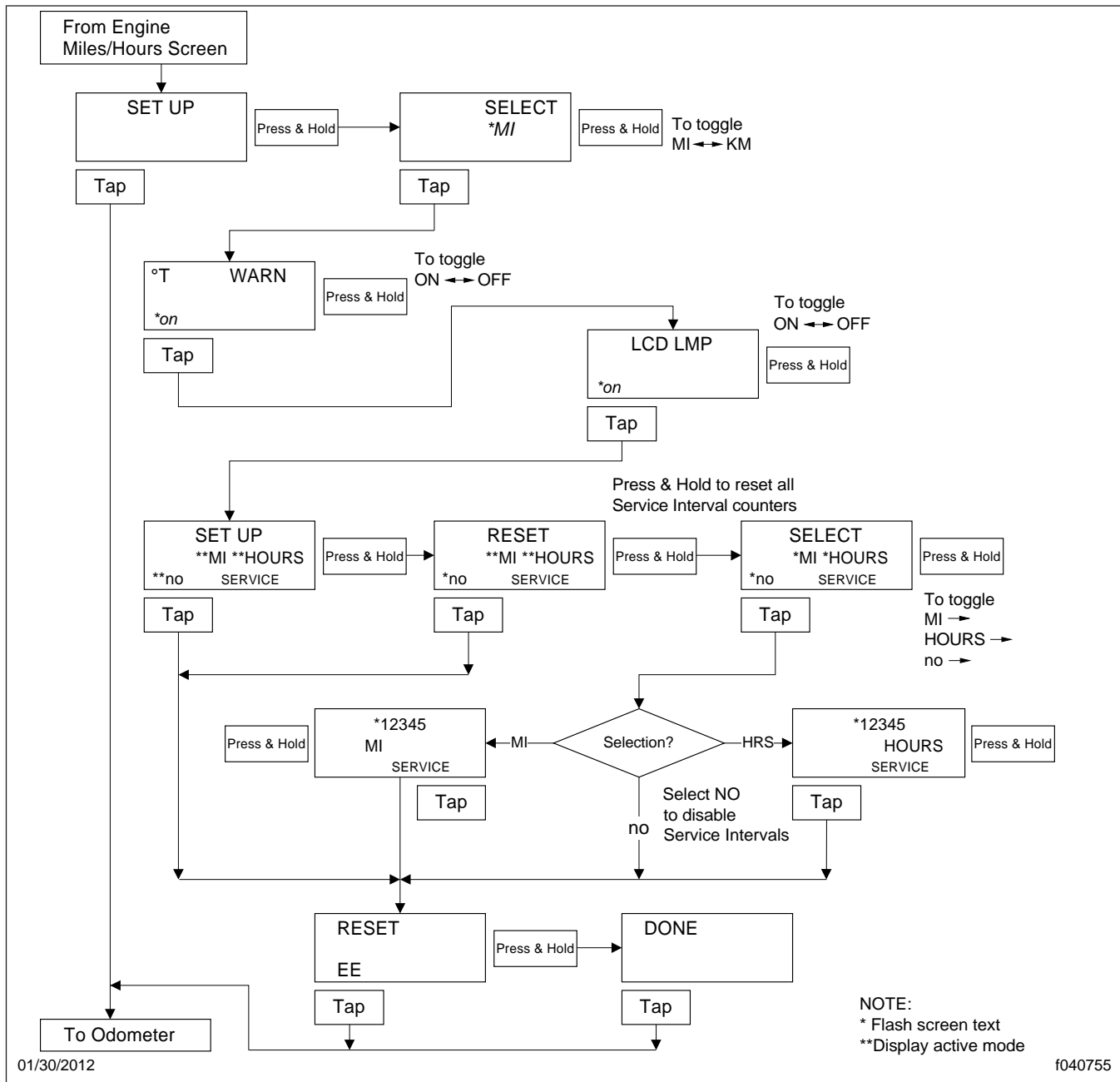

Fig. 4.12, ICU4 Setup Screens

10. no datalink activity

Incoming Message

On vehicles with a Qualcomm onboard communications system, a notification appears on the driver message center whenever a message is received.

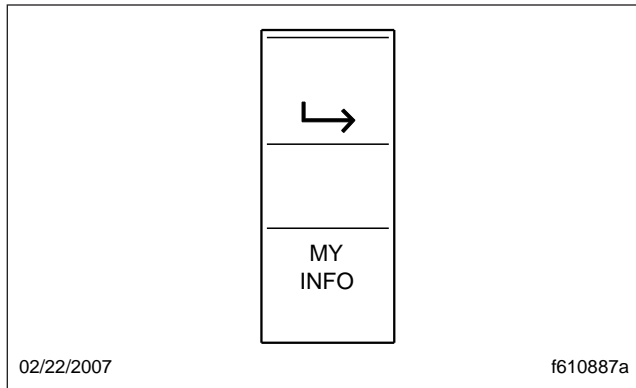

Fig. 4.13, MY INFO Switch

NOTE: The incoming message screen also displays during the ignition sequence if a message is available.

This message displays for a preset time period, then returns after a preset interval until it is dismissed by the + and - switches or the MY INFO switch.

Parking Brake On

This warning message and an audible warning come on whenever the parking brake is applied and the vehicle is moving faster than 2 mph (3 km/h). See [Fig. 4.14](#). The screen and audible warning go away only when the parking brake is released, or speed is reduced below 2 mph.



Fig. 4.14, Parking Brake On Alert Message

Low Oil Pressure

This warning message and an audible warning come on whenever the oil pressure falls below the minimum oil pressure, whether the vehicle is idling or in motion. Tap the + and - switches or the MY INFO switch to dismiss the message.

If low oil pressure is detected during the ignition sequence, it displays as an active fault instead of an alert message. After 30 seconds, the message displays again.

High Coolant Temp

This message and an audible warning come on whenever the engine coolant temperature exceeds the maximum allowable temperature.

If high coolant temperature is detected during the ignition sequence, it displays as an active fault instead of an alert message. After 30 seconds, the message displays again.

Low Voltage

On some vehicles, this optional message and an audible warning come on whenever a low voltage condition is detected.

Turn Signal On

This warning message and audible warning come on whenever the turn signal remains on for four minutes or five miles of travel. To dismiss this message, either turn off the turn signal or tap the + and - switches or the MY INFO switch.

Air Temperature

When the outside air temperature drops below 35°F (1.7°C), a warning text is displayed at one-second intervals for five seconds, and an audible warning will sound. Tap the + and - switches or the MY INFO switch to acknowledge the warning. The alert message will not occur again unless the temperature cycles above 37°F (4°C) and back below 35°F (1.7°C). This warning only occurs while the ignition is on and the parking brake is off.

Service Warnings

Service warning alerts display during the ignition sequence and indicate if a service interval has been reached or exceeded and maintenance is required. The messages may indicate the number of miles (KM) or hours until the next required service or, once passed, the number of miles (KM) or hours since maintenance should have been performed.

Automated Transmission Display

The ICU4M can display current gear information for vehicles with an automated transmission. The last three digits at the far right on the lower line of the driver message center are reserved for this information.

Instruments

When a shift request is made by the driver, an up or down arrow is also displayed, depending on the shift direction.

For more information about specific models of automated transmissions, see [Chapter 15](#).

Driving Screens

The following screens are available when the parking brake is off (when the vehicle is mobile).

Tap the MY INFO switch to drill down from each main screen to the submenus contained within it. Use the + and - switches to scroll through screens and select options. Tap the MY INFO switch again to exit each change screen. See [Fig. 4.15](#).

- i. Fasten seat belt (rpm<100)
- ii. Fuel economy (rpm>100)

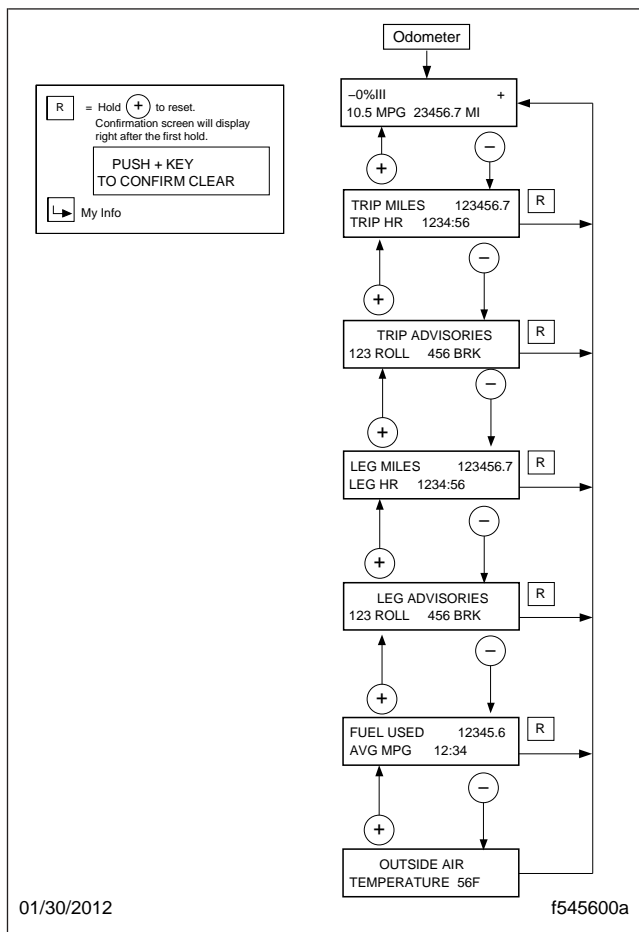

Fig. 4.15, ICU4M Driving Screens

- iii. Odometer
- iv. Trip distance/hours
- v. Trip advisory
- vi. Leg distance/hours
- vii. Leg advisory
- viii. Fuel used/average MPG (KM/L)
- ix. Outside air temperature

Favorite Screen

The driver can set a favorite driving screen using the MY INFO switch. Press and hold the lower half of the MY INFO switch for just over one second to set the current screen as the favorite screen. A chirp will sound to verify the screen has been set.

Tap the lower half of the MY INFO switch to access the favorite screen. Tap the MY INFO switch again to leave the favorite screen.

NOTE: Only driving screens can be set as the favorite screen.

Parked Screens/Menus

Tap the MY INFO switch to drill down from each main screen to the submenus contained within it. Use the + and - switches to scroll through screens and select options. Tap the MY INFO switch again to exit each change screen. Press and hold the + switch or the upper half of the MY INFO switch to reset the counters for trip and fuel information.

The following screens are available when the parking brake is on (when the vehicle is parked). See [Fig. 4.16](#).

- i. Odometer
- ii. Trip information including trip miles/hours, idle hours, average speed, leg miles/hours
- iii. Fuel information including fuel used, fuel economy, idle/PTO fuel usage
- iv. Engine information including engine miles/hours, engine/PTO gallons, oil level
- v. Diagnostic information
- vi. Service information including mileage or time to next service
- vii. Setup information

viii. Vehicle information including Datalink status, ICU serial number, software version

Diagnostic Information

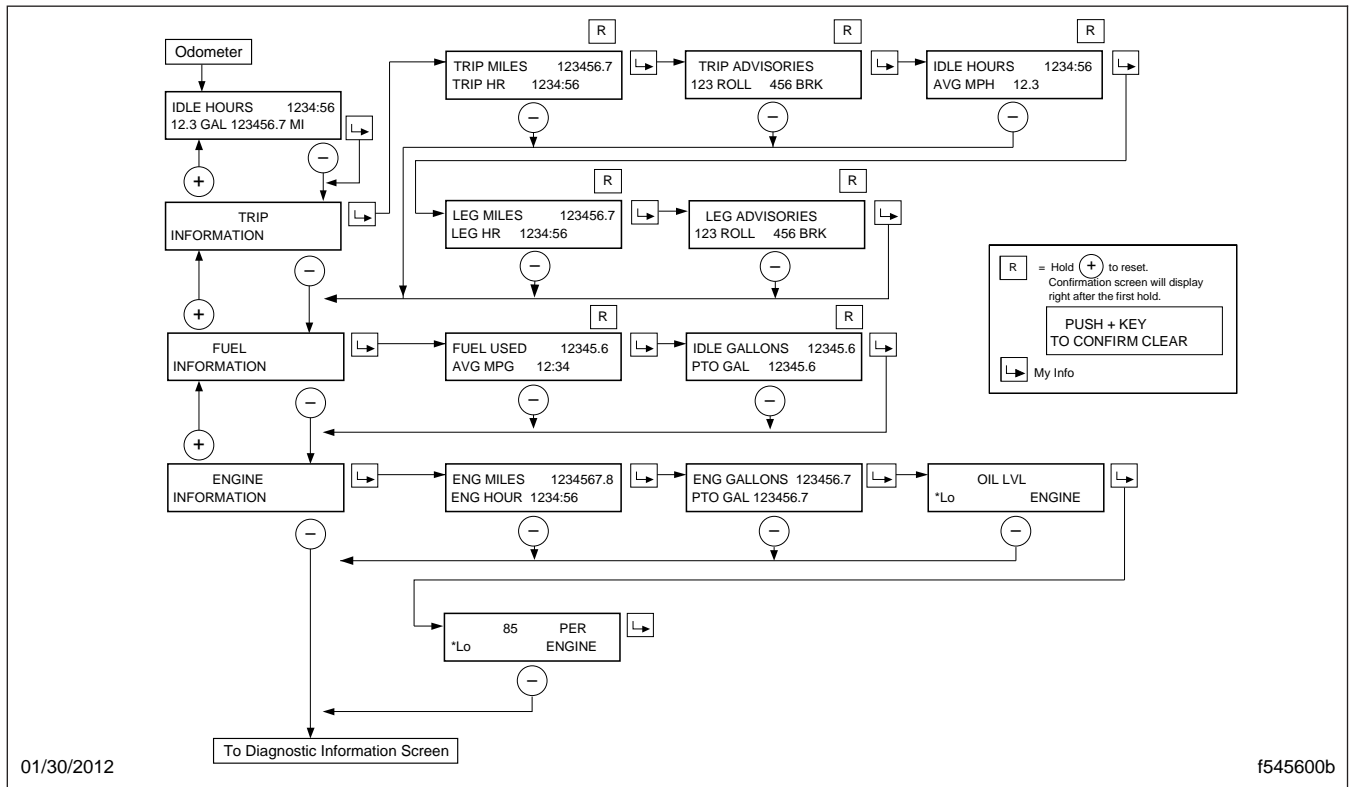

Fig. 4.16, ICU4M Idle Hours, Trip Information, Fuel Information, and Engine Information Screens

- ix. Outside air temperature
- x. Fasten seat belt warning

Trip Information

Trip Information displays the trip miles, trip advisories, idle hours, leg miles, and leg advisories, in that order.

Fuel Information

Fuel information displays total fuel usage since the last reset, fuel mileage, and fuel consumed while idling or running the PTO, in that order.

Engine Information

Engine information displays engine mileage and hours, and total fuel consumption, in that order.

If active fault codes are displayed on the diagnostic information screens, make a note of the fault code and text message, then take the vehicle to an authorized Freightliner service facility See [Fig. 4.17](#) for a diagram of the diagnostic information screens.

Service Information

The Service Information menu displays the next service interval, expressed in either miles or hours. See [Fig. 4.17](#). Service intervals can also be deactivated. For programming service intervals, see **Setup Information**, below.

NOTE: If the vehicle has exceeded the service interval, the **miles(km)/hours remaining** screen is replaced by the **service was due** screen, followed by the number of miles(km)/hours since the service was due.

Instruments

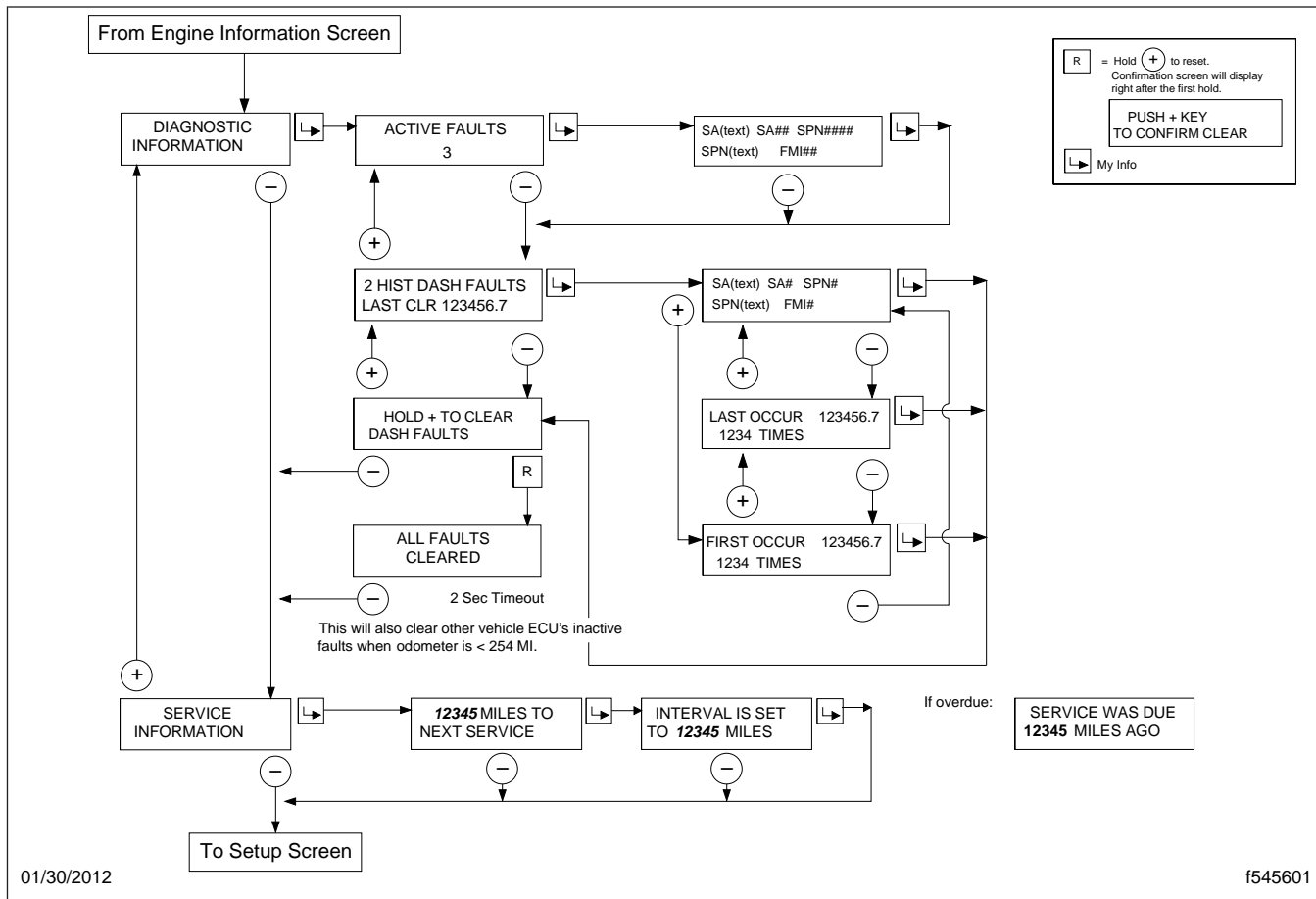

Fig. 4.17, ICU4M Diagnostic Information and Service Information Screens

Setup Information

The Setup Information menu allows the driver to program various features of the ICU4M. See [Fig. 4.18](#).

The setup features include:

1. Service intervals (OFF/MILES/HOURS)
2. Outside temperature warning (ON/OFF)
3. Target MPG
4. LCD lamp (ON/OFF)
5. Driver message center brightness
6. Language (English/French/Spanish)
7. Units of measurement (English/Metric)
8. Driver select (ON/OFF)
9. Reset parameters to original settings

Vehicle Information Screens

The vehicle information screens display hardware and software information, including the Freightliner part number and switch ID of the ICU. See [Fig. 4.19](#).

ICU4Me

Functions

ICU4Me settings and the driver message center are controlled using the ICU4Me control switch located on the dash, and the + and - switches mounted in the right-hand pod of the steering wheel. See [Fig. 4.20](#) and [Fig. 4.9](#).

The driver message center is divided into four sections. The odometer and cruise control status field are displayed along the bottom of the message center. When cruise control is active, the cruise control

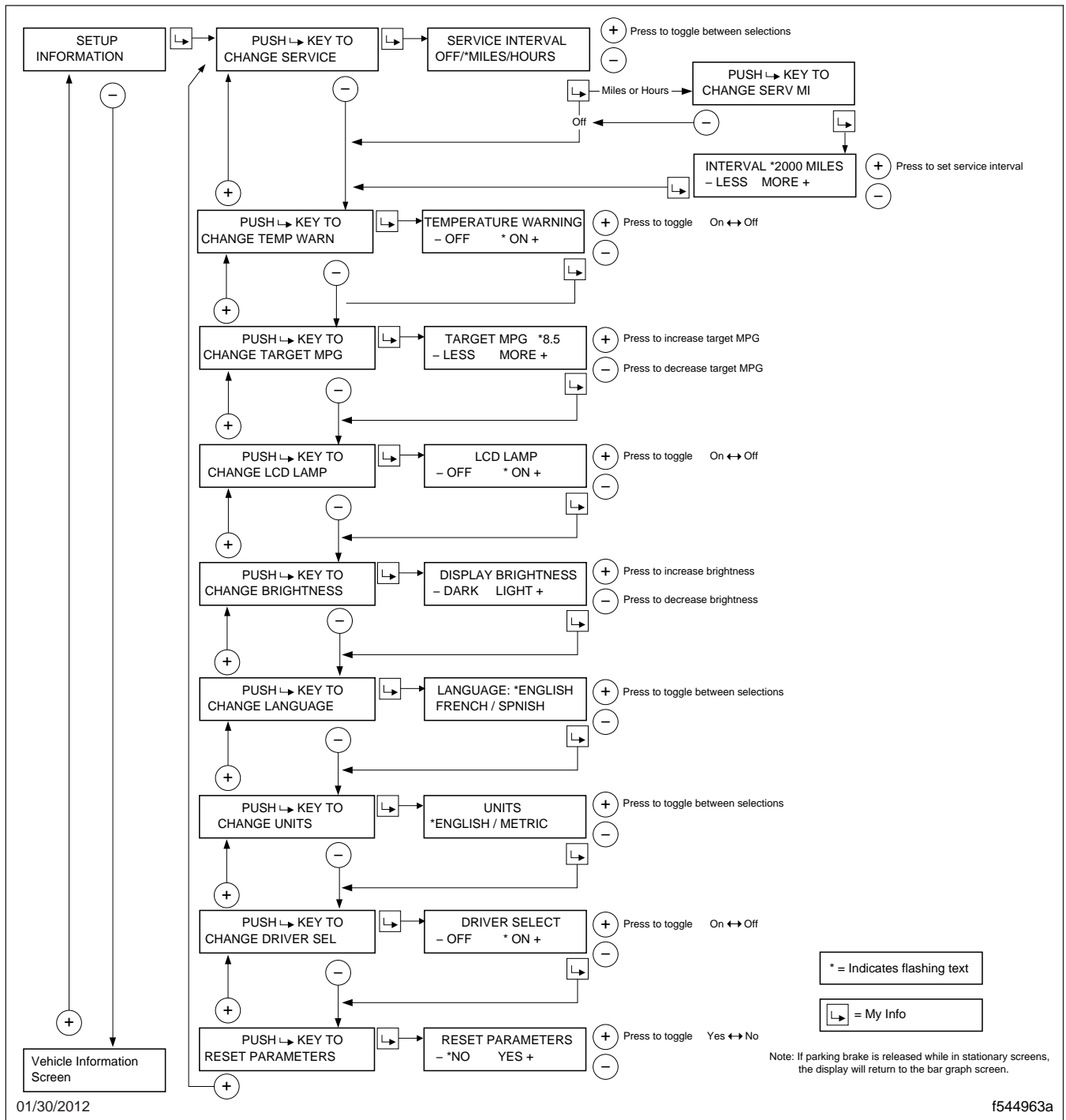

Fig. 4.18, ICU4M Setup Information Screens

status field displays relevant cruise control icons and the set speed. If the vehicle is equipped with a

Instruments

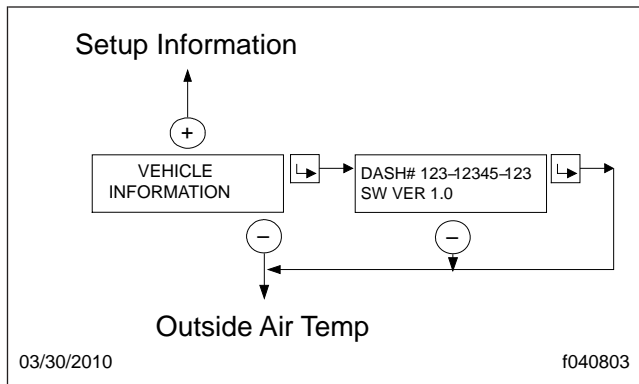

Fig. 4.19, ICU4M Vehicle Information Screens

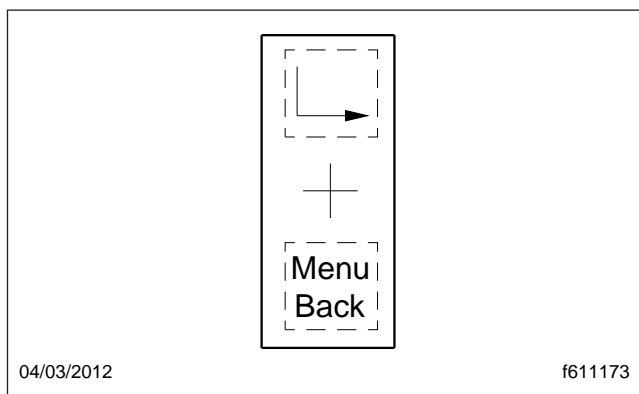

Fig. 4.20, ICU4Me Control Switch

manual transmission, time and temperature are displayed in the top left corner of the driver message center. The message field displays the driving screens and alert messages. See [Fig. 4.21](#).

If the vehicle is equipped with an automated transmission, the gear display is located in the top left corner of the driver message center. Time and temperature are displayed in the message field, unless an alert message is active or a driving screen has been selected. The odometer and cruise control status field are displayed along the bottom of the message center. See [Fig. 4.22](#). For information about transmission display options, see [Chapter 15](#).

Alert Messages

Alert messages are displayed in the message field to notify the driver when certain conditions occur. They include warnings, cautions, and other messages that require the driver's attention. Not all alert messages are critical to the operation of the vehicle. More im-

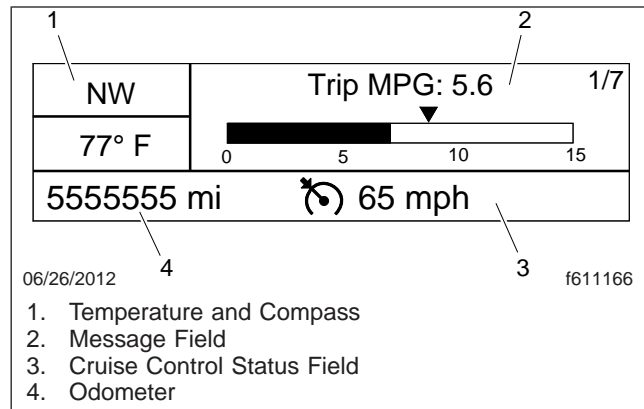

Fig. 4.21, Driver Message Center Without Gear Display, ICU4Me

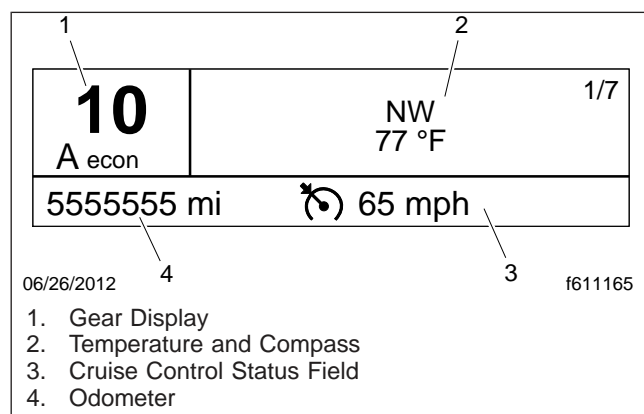

Fig. 4.22, Driver Message Center with Gear Display, ICU4Me

portant messages take priority over less important messages.

NOTE: All alert messages follow the format shown in [Fig. 4.23](#).

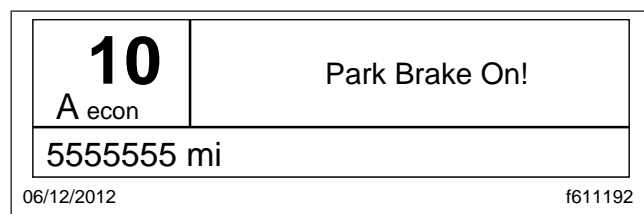

Fig. 4.23, Parking Brake Alert Message

Press the + switch to acknowledge alert messages and revert to the previously displayed driving screen.

The following alert messages will repeat intermittently until the condition is eliminated:

- turn signal on
- low voltage
- no datalink
- low transmission air pressure (Detroit transmissions only)

Driving Screens

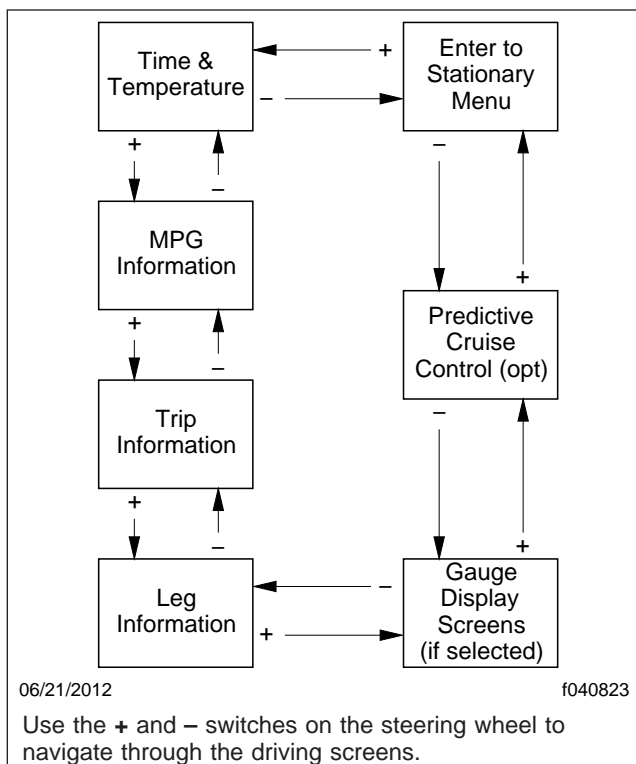

Fig. 4.24, Driving Screen Navigation, ICU4Me

With the parking brake off, only the driving screens are available. Use the + and - switches on the steering wheel to scroll through the driving screens; see [Fig. 4.24](#). To reset any values, press and hold the + switch.

- Temperature
- MPG information
- Trip information
- Leg information

- Gauge display (if selected)
- Predictive Cruise Control (optional)
- Enter parked menus

Parked Screens/Menus

Park the vehicle and set the parking brake to access the parked menus and submenus. See [Fig. 4.25](#). To reset values in any of the menus, press and hold the + switch.

- Trip information
- Fuel information
- Engine information
- Diagnostics
- Service information
- Settings

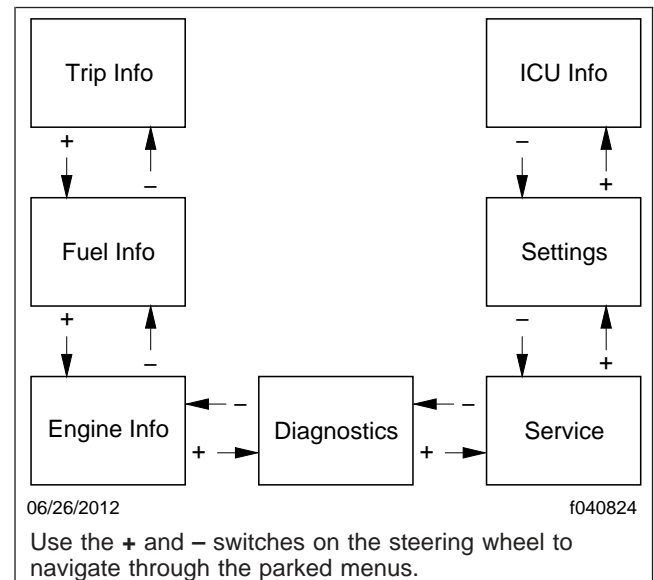

Fig. 4.25, Parked Menus, ICU4Me

- ICU Information

A small numerical fraction is displayed in the upper right-hand corner of each screen to indicate the number of available screens or options to scroll through. See [Fig. 4.26](#). Press the upper half of the ICU4Me control switch to select a menu choice. Press the lower half of the control switch to back out of a selected menu or submenu. Use the + switch to scroll up, and the - switch to scroll down.

Instruments

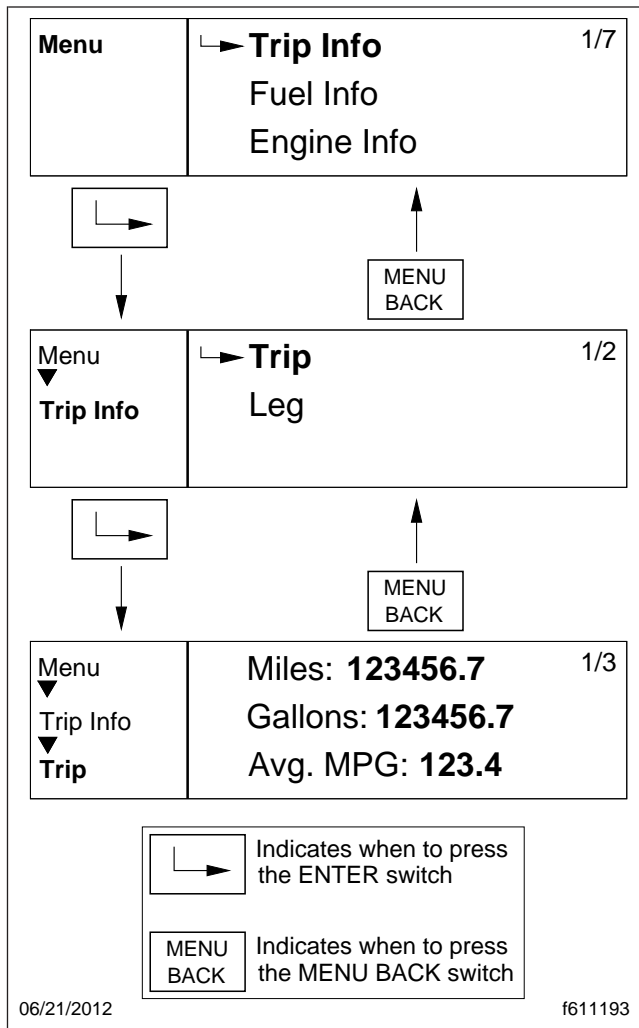

Fig. 4.26, Parked Menu Navigation, ICU4Me

When navigating the parked menus, the left side of the driver message center displays a "breadcrumb menu" to show the order of menus and submenus that have been selected during the current navigation.

Trip Information

The ICU can record data for one trip segment and one leg segment. When trip information is reset, all the leg information is reset as well.

Fuel Information

Using this menu, the driver can view the total fuel used since the last reset, the total idle gallons used

since the last reset, and the average MPG since the last reset.

Engine Information

Using this menu, the driver can view engine miles, engine hours, gallons used, PTO hours, and PTO gallons. Engine oil level is optional for Detroit engines. The information contained in the Engine Information screens cannot be reset.

Diagnostics

Active and historical faults are displayed in the diagnostics menu. See Fig. 4.27. If there are any active faults, the total number of faults is displayed in parenthesis next to the affected controller. To view specific active faults, press the upper half of the ICU4Me control switch on the dash. Press the upper half of the ICU4Me control switch to toggle between the text description and the failure code for each selected fault.

Service Information

Using this menu, the driver can enable, disable, and set service intervals for engine miles or engine hours. After enabling service intervals, select interval unit (miles or hours), and the interval duration.

Settings

The settings menu contains the controls for the following settings:

- Display (includes brightness, contrast, display light, and night mode settings)
- Gauge select
- Language
- Self-test
- Temperature warning enable/disable
- Units

The Gauge Select submenu allows the driver to select certain gauge values for display in the message field while driving. See Fig. 4.28. Use the + and - switches on the steering wheel to scroll through the list of available gauges, then press the upper half of the ICU4Me control switch to select a desired gauge. The ICU4Me control switch can also be used to uncheck boxes if necessary.

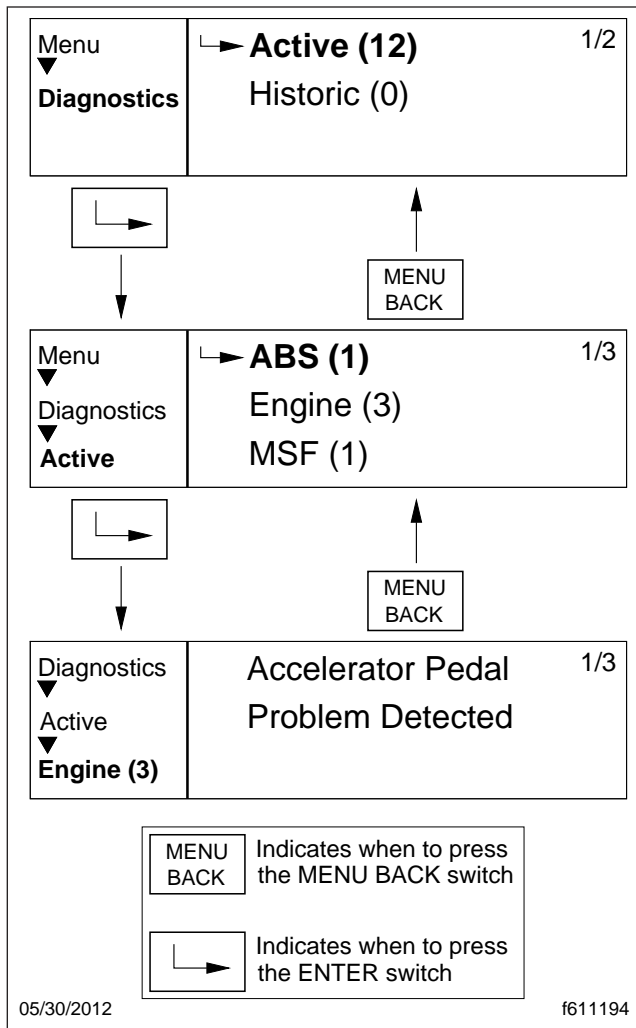

Fig. 4.27, Diagnostics Menu Navigation, ICU4Me

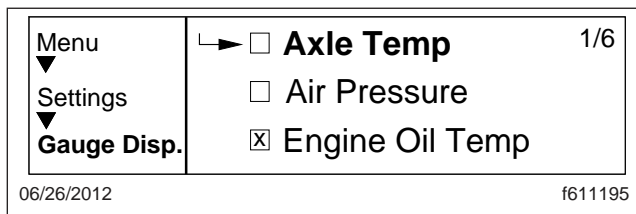

Fig. 4.28, Selecting Gauges to Display, ICU4Me

ICU Information

The ICU Information screen displays the part numbers for the instrument cluster and software.

Overhead Instrument Panel

The optional overhead instrument panel may hold a citizen's band (C/B) radio and any switches that can not be accommodated on the driver's or auxiliary dash panels.

The underside of the overhead console also holds the sun visors and the optional dome/reading light assembly. See [Chapter 5](#) for more information on the dome/reading light assembly.

5

Driver Controls

| | |
|--|------|
| Ignition Switch and Key | 5.1 |
| Lighting Controls | 5.2 |
| Horn Controls | 5.7 |
| Powertrain Controls | 5.7 |
| Cruise Control | 5.11 |
| Dash-Mounted Brake Controls | 5.14 |
| Windshield Wiper/Washer Controls | 5.15 |
| Suspension/Trailer Connection Controls | 5.16 |
| Climate Controls | 5.17 |
| Seat Controls | 5.19 |
| Adjustable Steering Column Controls | 5.20 |

Driver Controls

Ignition Switch and Key

The ignition switch is located on the left-hand dash, below the headlight switch. See [Fig. 5.1](#).

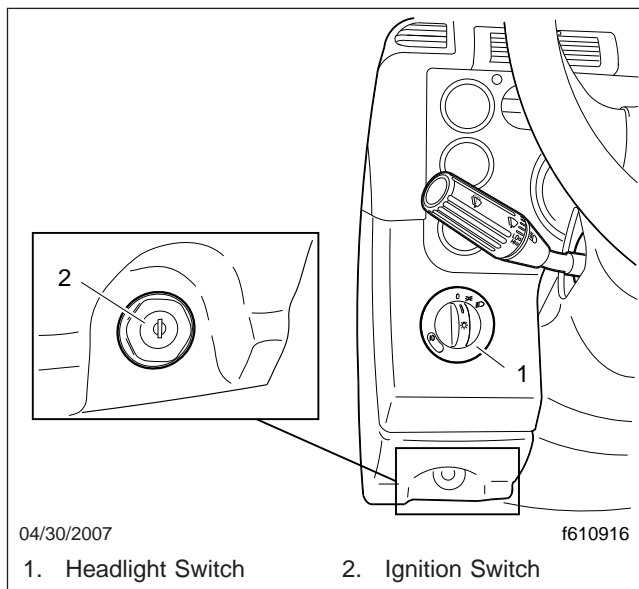

Fig. 5.1, Left-Hand Dash

The ignition switch has four positions: OFF, ACC (accessory), ON, and START. See [Fig. 5.2](#).

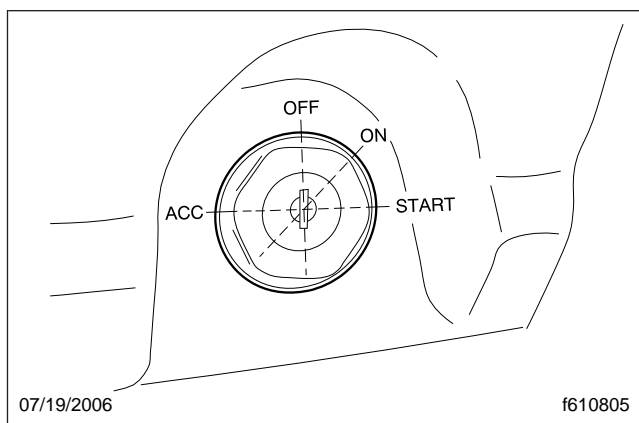

Fig. 5.2, Ignition Switch

In the OFF position, the ignition switch is vertical. The key can be inserted and removed only in the OFF position.

The following functions are operable when the ignition switch is in the OFF position (regardless of whether the key is inserted):

- low-beam headlights
- taillights
- brake lights
- road lights
- dome lights
- clearance lights
- hazard warning lights
- utility lights
- baggage compartment lights
- spotlights
- electric horn
- clock
- refrigerator
- CB radio
- power mirrors
- power receptacle
- fuel heater
- electric oil pan heater
- electric or diesel-fired engine coolant pre-heater

Turn the key counterclockwise to reach the ACC position. In addition to all the functions that are operable in the OFF position, the following functions are operable when the switch is in the ACC position:

- radio/stereo system
- heater and A/C fan
- mirror defog
- windshield fan
- ether start system
- air dryer
- backup lights

Turn the key clockwise past the OFF position to reach the ON position. With the switch in the ON position, all electrical systems become operable and

the warning and indicator lamps illuminate. Wait for three seconds before starting the engine.

The SAM Cab vehicle controller automatically cycles all exterior lights off and then on when the headlamps are on and the park brake is released, or set. This rapid flash of the exterior lights is a self-test to detect any bulb that is not operational. Drivers may notice all lights flash simultaneously during this process. This is the normal operating sequence. A fault code is set for any bulb that is out.

IMPORTANT: Do not crank the engine until the ICU self-check is complete.

Turn the key clockwise past the ON position to reach the START position to start the engine. Release the key the moment the engine starts. Do not operate the starter longer than thirty seconds, then allow the starter to cool between attempts. If the starter overheats, the starter protection system will prevent operation of the starter until it has cooled. Release the key the moment the engine starts.

The ignition key also locks and unlocks the cab doors, the baggage door(s) and if equipped, the bunk door(s).

Lighting Controls

IMPORTANT: Unless otherwise noted below, press the upper half of the switch to activate the desired light(s). Press the lower half of the switch to turn the light(s) off.

Exterior Lighting Controls

Exterior light controls are listed here in alphabetical order. See [Fig. 5.3](#) for exterior light locations.

Auxiliary High Beam Lights

Auxiliary high-beam lights may be located in the front bumper. To activate the auxiliary high beam lights, press the upper part of the dash switch. The auxiliary high beam lights will illuminate only when the high-beam headlights are on. They will switch off temporarily when the low-beam headlights are on, until the high beams are on again. Press the lower half of the switch to deactivate it. See [Fig. 5.4](#).

Backup Lights

Backup lights activate only when the vehicle is in reverse, and are designed to be used while backing up at night.

Daytime Running Lights

The daytime running lights (DRL), if equipped, are automatically activated when the ignition is switched on and the parking brake is released. The DRL turn off when the engine falls below 400 rpm, the parking brake is applied, or the headlights are turned on.

Daytime running lights are mandatory for vehicles domiciled in Canada. Vehicles domiciled in any other location may have an optional override switch ([Fig. 5.4](#), ref. 2). This is a momentary switch that enables the driver to deactivate the DRL. Press the upper half of the switch briefly to activate or deactivate the DRL.

Fog Lights

Fog lights are designed to reduce glare in foggy conditions. The low-beam headlights must be on in order to turn the fog lights on. Pull the headlight switch outward to activate the fog lights.

Hazard Warning Lights

The hazard warning light switch is located on the dash in what is referred to as the master module. See [Fig. 5.5](#). The hazard lights can be activated regardless of the ignition switch position.

To activate the hazard lights, press the center of the switch once. The switch will blink at the same rate that the hazard lights flash. Press the switch again to turn them off. All the turn signals on the vehicle and trailer, as well as the turn signal indicators in the ICU, flash simultaneously when the hazard lights are activated.

Headlights

The headlight switch is a rotary switch located to the left of the steering column, above the ignition switch. See [Fig. 5.6](#).

If the Follow Me Home feature is activated, the low-beam headlights will remain on for nine seconds after the vehicle is parked, if the headlights were on prior to engine shutdown. This feature provides temporary lighting in the path of the headlights while walking to a building or other destination. If a vehicle

Driver Controls

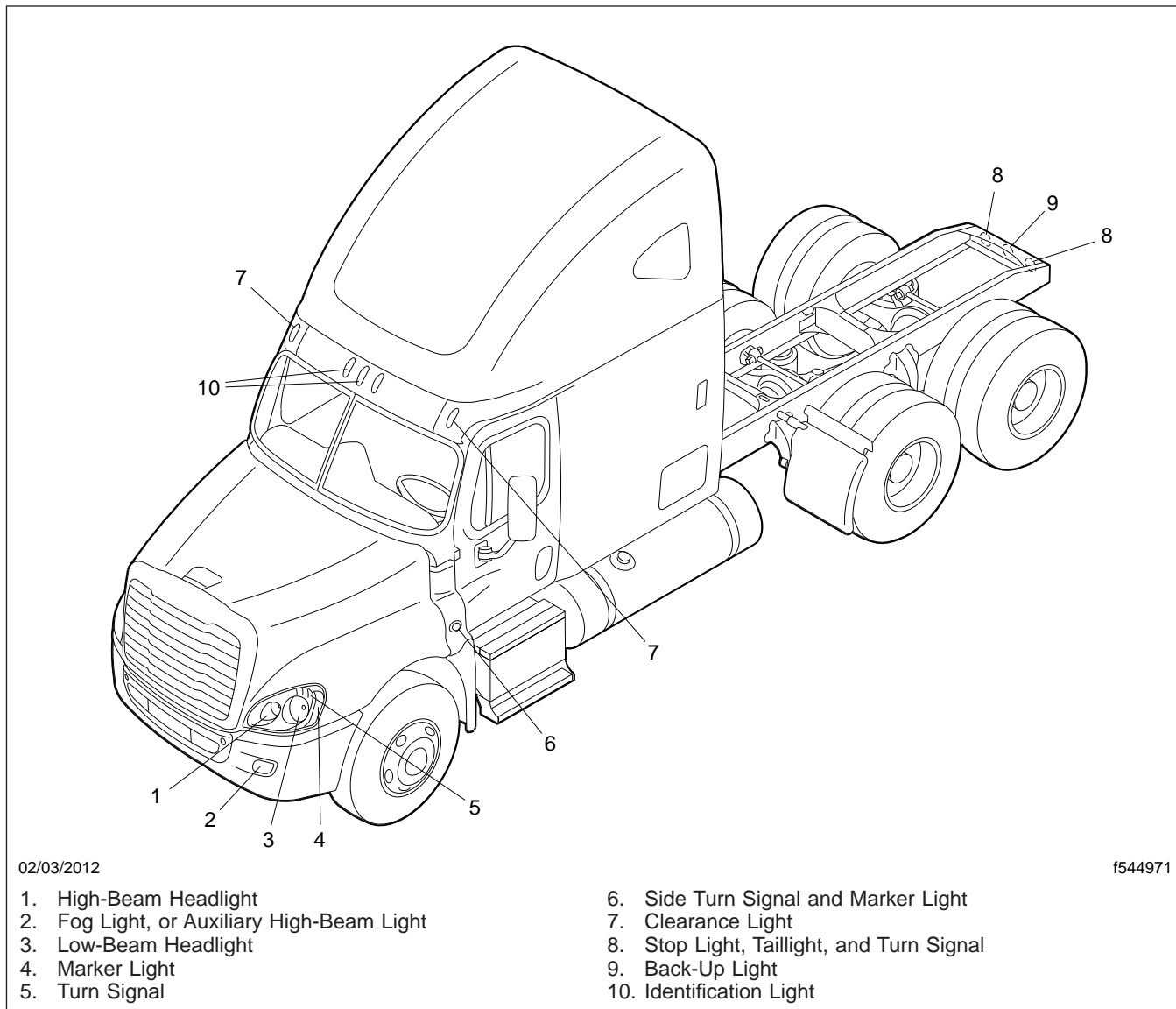

Fig. 5.3, Exterior Lights

door is opened or closed while this feature is active, the timer will add an additional 10 seconds of lighting. This feature can be temporarily disabled by turning the ignition switch on, or by cycling the headlight switch from the off position to one of the other two positions.

High-Beam Headlights

To activate the high-beam headlights, press the turn signal lever forward towards the windshield while the

low-beam headlights are on. Return the turn-signal lever back to its neutral position to deactivate the high beams, and return to low beam headlights.

When the high-beam headlights are on, a blue light illuminates on the instrument cluster. For vehicles with fog lights, switching on the high beams will switch off the fog lights. The headlight low beams remain on continuously during high-beam operation.

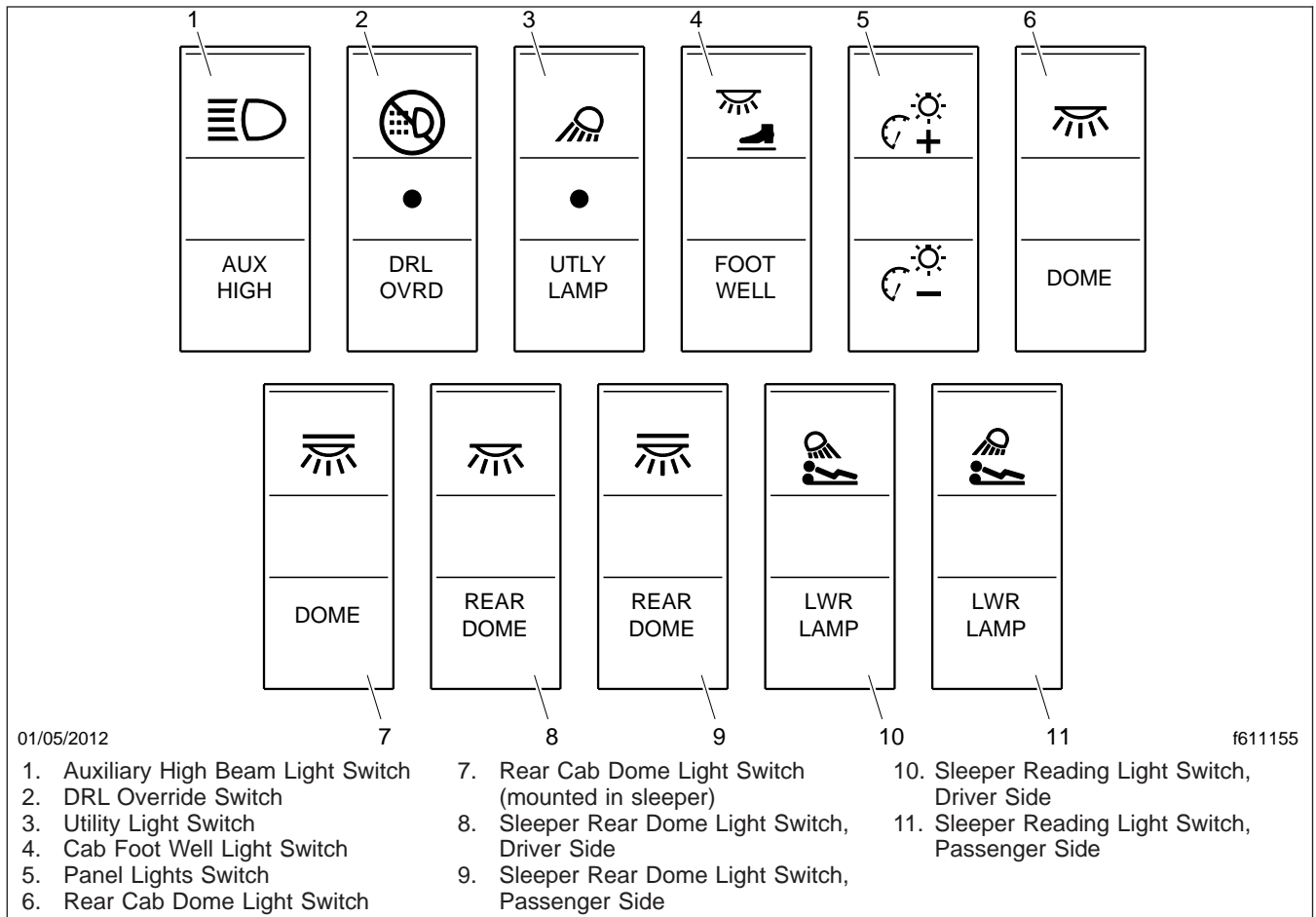

Fig. 5.4, Dash-Mounted and Sleeper-Control Light Switches

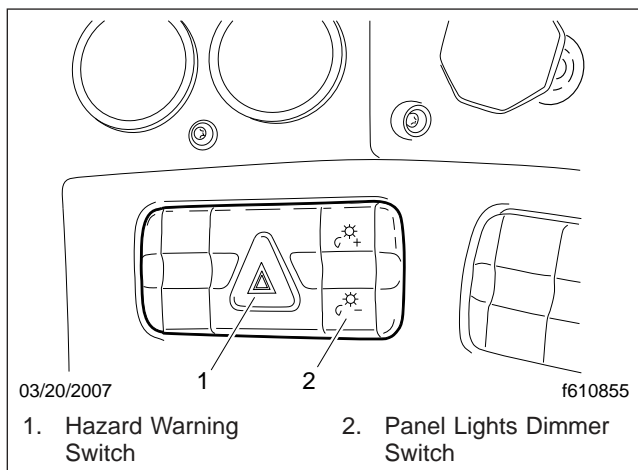

Fig. 5.5, Master Module

NOTE: The ignition switch must be on for the high beams to work.

Marker Lights

Turn the headlight switch clockwise to past the off position. See [Fig. 5.6](#).

Marker Interrupt

The marker interrupt switch, located in the right-hand switch pod of the steering wheel, temporarily flashes the marker lights. See [Fig. 5.7](#).

Driver Controls

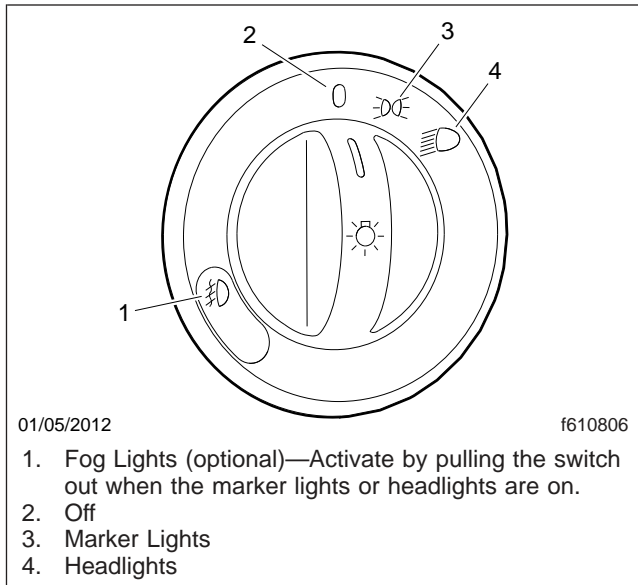

Fig. 5.6, Headlight Switch

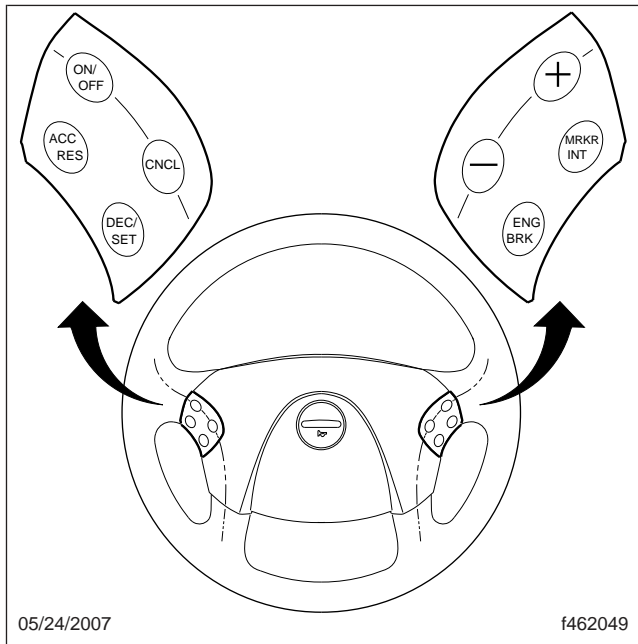

Fig. 5.7, Steering Wheel-Mounted Controls

Spotlight

The spotlight switch is located on the pivoting handle of the spotlight. There may be a single spotlight assembly mounted above the driver's door, or one above each door.

Turn Signals

The turn-signal lever is on the left side of the steering column. See [Fig. 5.8](#).

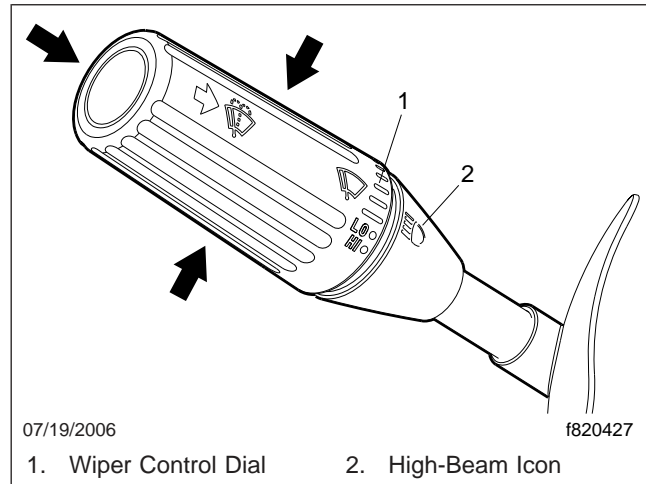

Fig. 5.8, Multifunction Turn Signal Lever

NOTE: The optional self-canceling turn signal lever will automatically return to the neutral position when the steering wheel returns to the straight-ahead position after a turn.

Move the turn signal lever downward to turn the left-turn signal on; move it upward to turn the right-turn signal on. To manually cancel the signal, move the lever to the neutral position.

When a turn signal is activated, a green indicator light flashes on the instrument cluster.

Turn-Tip Feature

The turn-tip feature is advantageous in lane change situations when the steering wheel does not travel far enough to cancel a conventional turn signal request. Pushing the turn-signal lever halfway to the normal turning position to activate the turn-tip feature. The signal will flash for a few seconds, then cancel. Activation of the turn-tip feature is immediately canceled when a request for the turn signal in the opposite direction is made.

Utility Lights

Utility lights can be swivel-mounted on upper half of the cab, mounted on the exhaust support, or flush-mounted on the back of the cab or sleeper. Press the upper half of the switch to activate it. Press the lower

half of the switch to turn it off. When activated, a red indicator light in the switch is illuminated. See [Fig. 5.4](#).

Interior Lighting Controls

Interior light controls are listed here in alphabetical order.

The interior lights include panel lights, dome lights, red map lights, clear reading lights, and courtesy lights. Vehicles come pre-set from the factory with theater lighting, which ramps up lights from low power to full power when activated.

Sleepers have rear dome lights, bunk reading lights, sleeper floor lights, and baggage compartment lights.

Baggage Compartment Lights

Baggage compartment lights are located on the underside of the lower bunk, on both sides. Both lights turn on when either baggage compartment door is opened to illuminate the baggage compartment. The lights also come on when the lower bunk is raised.

Foot Well Lights

When the driver or passenger doors are opened, red lights illuminate both foot wells. These lights can also be activated with the foot well light switch. See [Fig. 5.4](#). Press the upper half of the switch to turn the foot well lights on, press the lower half of the switch to turn them off.

Overhead Console Lights

The overhead console includes a clear reading light, a clear dome light, and a red map light. See [Fig. 5.9](#). The dome lights illuminate when a door opens, then stay on for a short time after both doors are closed. Press the lens of the reading light, dome light, or map light to activate each one independently of the others.

Panel Lights

The panel lights illuminate when the headlights are turned on. To adjust the brightness of the panel lights, use the panel lights switch, usually located in the master module next to the hazard flasher switch. See [Fig. 5.4](#). The panel lights brighten and dim in 5% increments, depending on whether the upper half or the lower half of the switch is pressed. When the

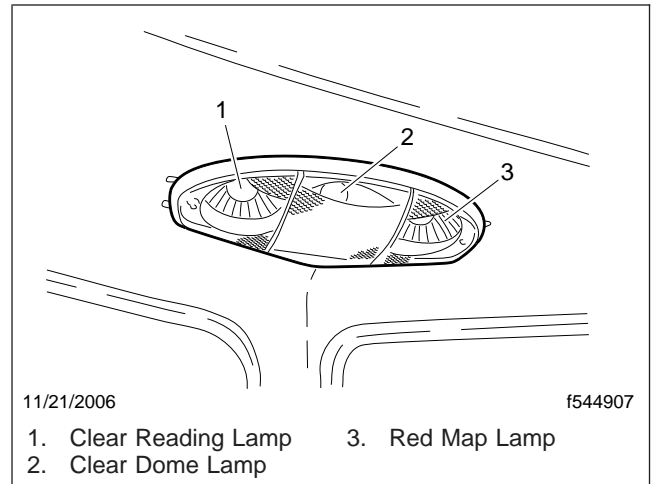

Fig. 5.9, Overhead Console Lights

headlights are turned on, the panel lights setting will default to the intensity that was last set.

Rear Dome Light

A rear cab dome light is located on the roof, between the bunk and the cab on sleeper vehicles. See [Fig. 5.10](#). The rear cab dome light will activate with the dome lights when a door is opened, then stay on for a short time after both doors are closed.

Use the dash-mounted switch or the switch in the sleeper panel to activate the rear cab dome light. See [Fig. 5.4](#).

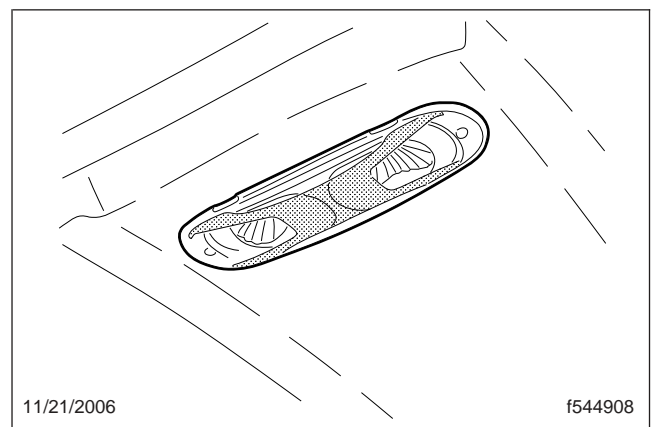

Fig. 5.10, Rear Cab Dome Light

Driver Controls

Sleeper Dome Light

Two dome lights are mounted on the sleeper roof, close to the outside walls.

There are two switches in the sleeper that control the sleeper dome lights. The passenger-side switch will activate both dome lights. The driver-side switch operates the driver-side light only. Press the upper half of the switch to turn the sleeper dome light on, press the lower half of the switch to turn it off.

Sleeper Foot Well Lights

The sleeper foot well switch is located in the lower switch module in the sleeper. It looks identical to the cab foot well switch. See [Fig. 5.4](#). When the switch is activated, two lights illuminate the sleeper floor.

Sleeper Reading Lights

Clear reading lights are mounted above the lower bunk in the rear corners of the sleeper. There are two switches in the sleeper control panel for the reading lights. To turn a reading light on, press the upper half of the switch. Press the lower half of the switch to turn it off. See [Fig. 5.4](#).

The reading lights can also be activated by pressing the lens.

Horn Controls

Air Horn

Air horn(s) may be mounted on the roof of day cabs, or under the driver-side floor for sleeper cabs. The air horn is controlled by a wire lanyard that hangs down inboard by the driver's door. See [Fig. 5.11](#). Pull downward on the lanyard to sound the air horn.

Electric Horn

The button for the electric horn on a vehicle without an airbag is located in the center of the steering wheel. See [Fig. 5.12](#). To sound the horn, press down on the button.

The electric horn on a vehicle with an airbag is activated by pressing down on the top of the steering wheel center pad. See [Fig. 5.13](#).

The horn will sound for the duration that the button is pressed, up to 60 seconds. The electric horn will operate regardless of the position of the ignition key.

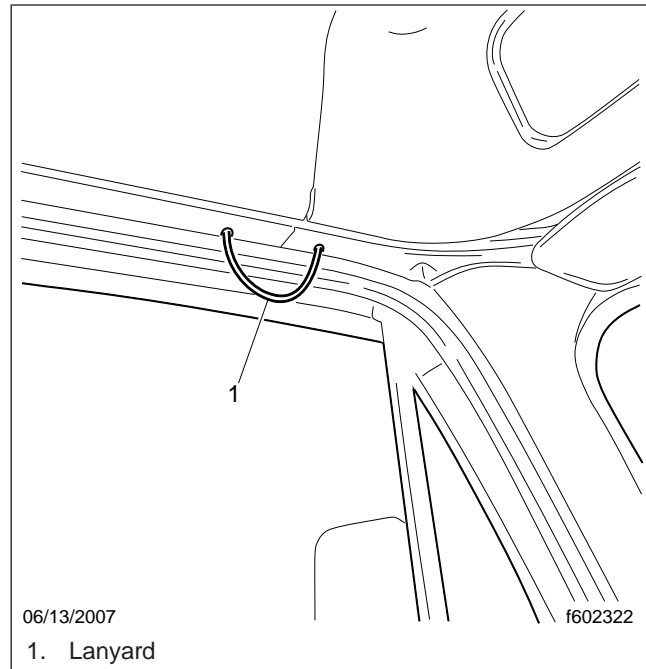

Fig. 5.11, Air Horn Control

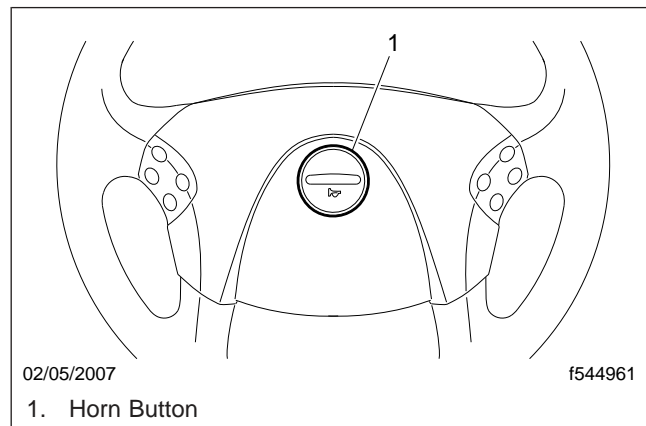

Fig. 5.12, Steering Wheel, No Airbag

Powertrain Controls

Aftertreatment System Regen Switches

NOTE: See [Chapter 12](#) for detailed information about the operation of the regeneration (regen) switches and the aftertreatment system (ATS).

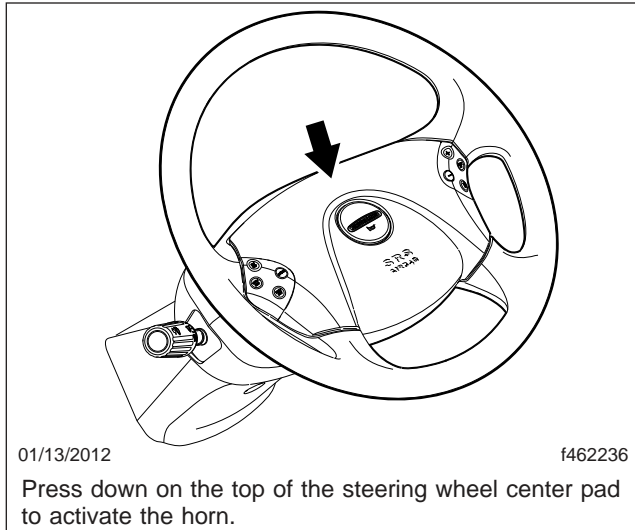

Fig. 5.13, Steering Wheel With Airbag

IMPORTANT: Depending upon local jurisdictional emissions guidelines, vehicles that are domiciled outside of the U.S. and Canada may not have engines and/or emissions aftertreatment systems that are compliant with EPA07, EPA10, or GHG14 regulations.

The regen request switch, located on the dash, is used to initiate a parked regen. See [Fig. 5.14](#). To access the regen request switch, lift the guard and press the yellow button.

Some vehicles may be equipped with a regen inhibit switch. See [Fig. 5.14](#). To stop a regen in progress or prevent the start of a regen, press the lower half of the switch. Regen will be delayed until the switch is no longer active.

Axle Switches

Some vehicles are equipped with an interaxle differential lock switch and/or a switch for each driver-controlled differential lock (DCDL). See [Fig. 5.15](#). For more information about differential locks and using them for traction control, see [Chapter 16](#).

Engine Brake Switch

The Hi/Med/Lo engine brake 3-position switch controls the amount of engine braking. See [Fig. 5.16](#). Press the lower third of the switch for low, center for medium, and upper third for high.

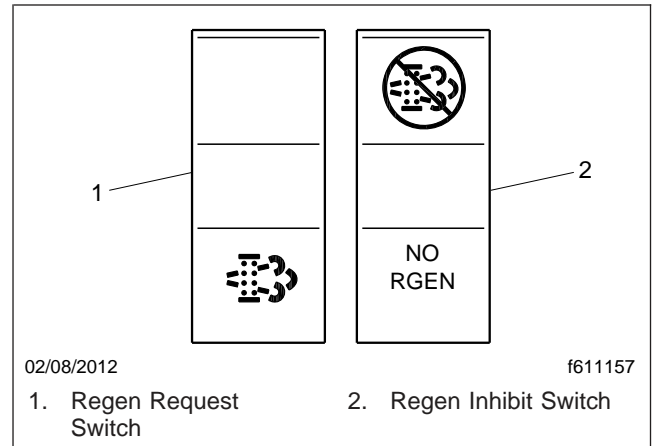

Fig. 5.14, Regen Request and Inhibit Switches

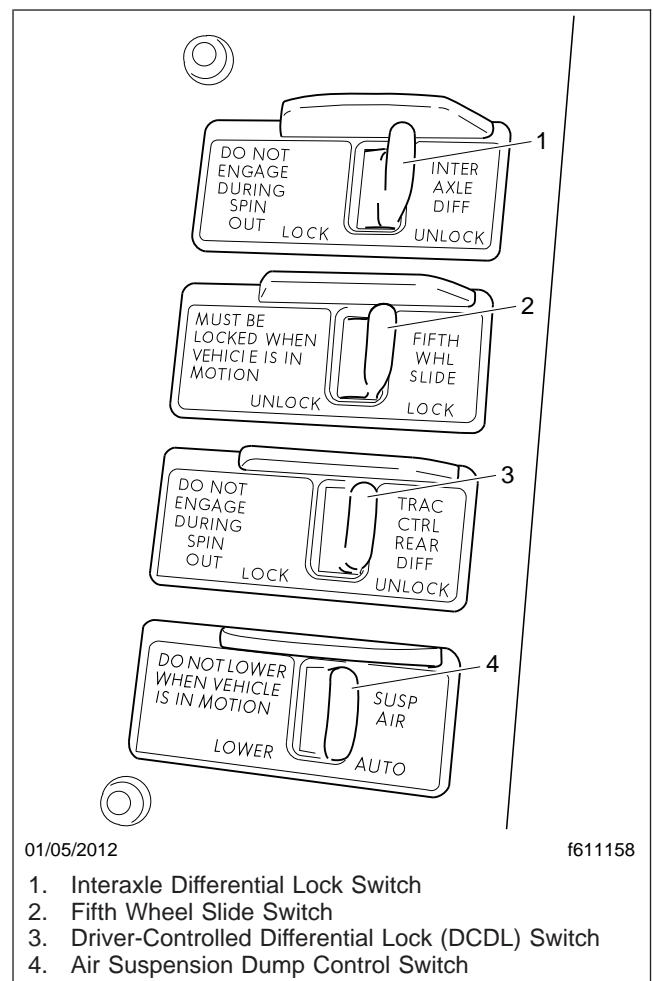

Fig. 5.15, Axle and Suspension Switches

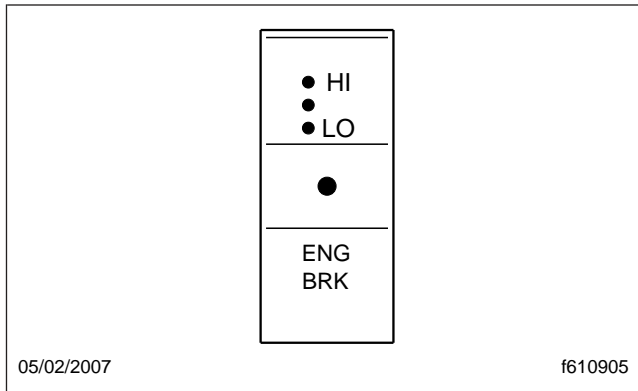

Fig. 5.16, Engine Brake Switch

There is also an engine brake switch located in the right-hand switch pod on the steering wheel. See [Fig. 5.7](#). Press the ENG BRK switch once to engage or disengage the engine brake. Refer to [Chapter 13](#) for instructions on using the engine brake.

Engine Fan Switch

The engine cooling fan can be turned on by the engine fan switch.

To turn the engine fan on, press the upper half of the switch. The fan will continue to operate for a set amount of time and then turn off unless the coolant temperature is high enough to continue fan operation. To turn the fan off before the set time period ends, press the lower half of the switch. See [Fig. 5.17](#).

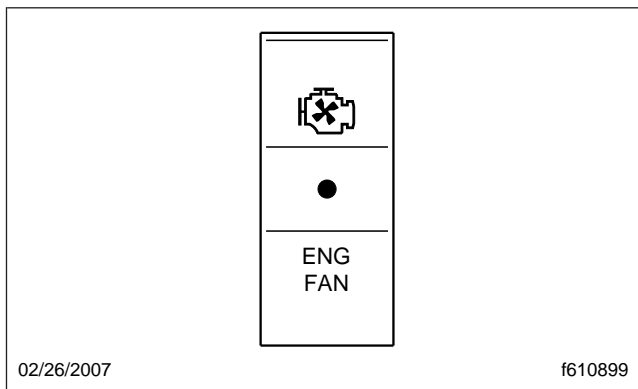

Fig. 5.17, Engine Fan Switch

Hill Start Aid Override Switch

Some vehicles are equipped with a Hill Start Aid (HSA) feature to prevent the vehicle from rolling while on steep grades and to allow for a controlled launch. HSA is "on" by default. It can be turned off by pressing and releasing the HSA override switch on the dash (see [Fig. 5.18](#)).

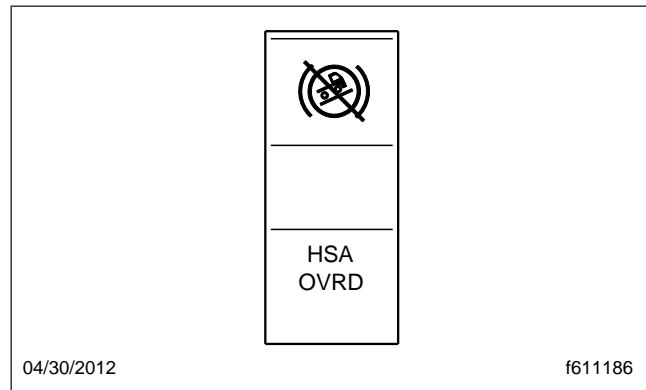

Fig. 5.18, Hill Start Aid Override Switch

PTO Switch

To activate the PTO function, press the upper half of the switch. Press the lower half of the switch to deactivate the PTO function. See [Fig. 5.19](#).



To avoid injury, do not install a PTO that is not Detroit Diesel approved onto a Detroit™ Transmission. Use of a non-Detroit Diesel approved PTO with a Detroit Transmission could result in unintended operation which could lead to severe personal injury.

Transmission Controls

Detroit™ Automated Transmissions

NOTE: See [Chapter 15](#) for complete Detroit automated transmission operating instructions.

Vehicles with Detroit transmissions use the multifunction control shown in [Fig. 5.20](#). This control moves in two directions and has two switches. It is used to request manual shifts, change shift mode, set engine brake levels, and control specialty engine brake functions during cruise control operation.

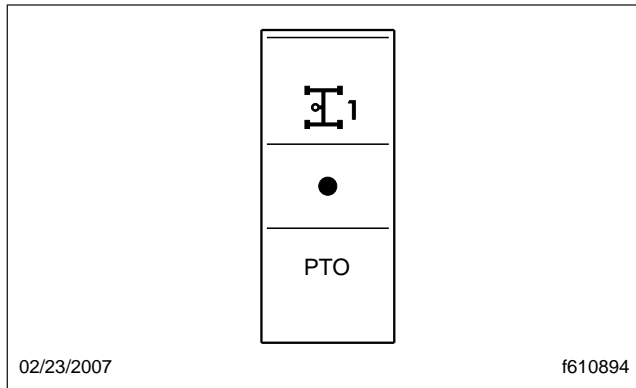

Fig. 5.19, PTO Switch

Eaton Automated Transmissions

NOTE: See [Chapter 15](#) for complete automated transmission operating instructions.

The SmartShift electronic transmission control is installed with the Eaton® Fuller® UltraShift™ and Eaton Fuller AutoShift™ transmissions. The SmartShift control is operated by the fingers of the driver's right hand, allowing both hands to remain on the steering wheel.

A two-position driving mode slide switch is mounted on the body of the control lever just before the paddle widens out. The slide switch allows the driver to choose automatic (AUTO) or manual (MAN) mode. See [Fig. 5.21](#).

Manual Transmissions

NOTE: See [Chapter 14](#) for complete manual transmission operating instructions.

If so equipped, the transmission range control and splitter valves are attached to the gear shift knob.

The range-preselection lever allows the selection of the low or high range for each transmission ratio. It is used once during an upshift sequence and once during a downshift sequence.

Dependent on the transmission model, some ratios can be split using the splitter-control button.

Allison Automatic Transmissions

Automatic transmissions have up to six forward speeds and one reverse speed. These transmissions have electronic shift controls that can be pro-

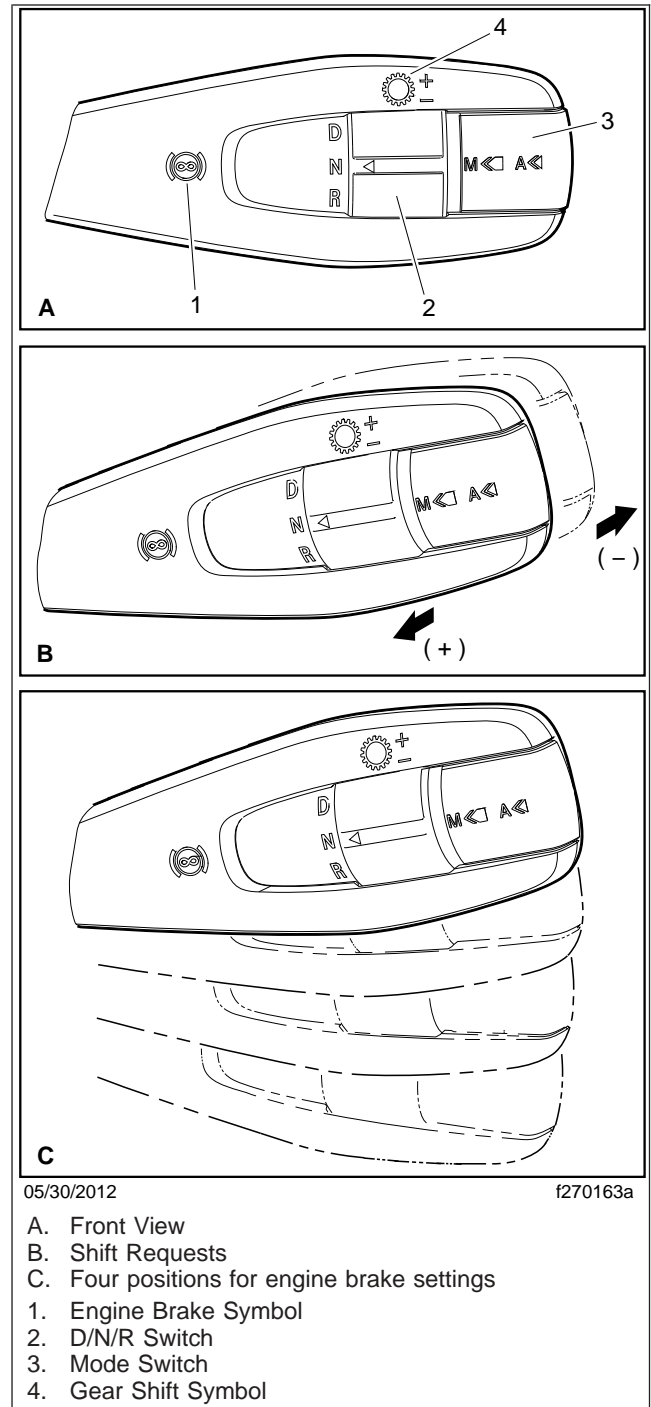

05/30/2012 f270163a
 A. Front View
 B. Shift Requests
 C. Four positions for engine brake settings
 1. Engine Brake Symbol
 2. D/N/R Switch
 3. Mode Switch
 4. Gear Shift Symbol

Fig. 5.20, Detroit Multifunction Control

grammed to allow the use of different geared speeds. See [Fig. 5.22](#).

Driver Controls

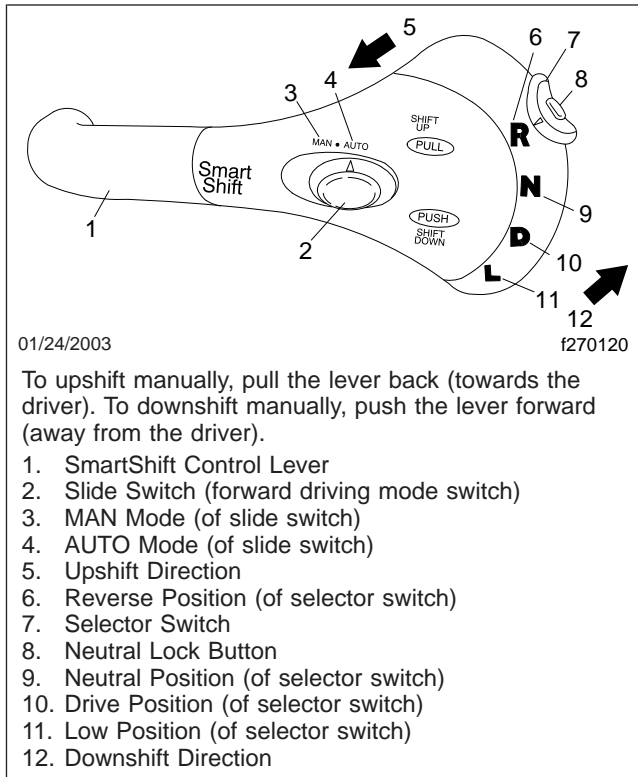

Fig. 5.21, SmartShift Control (Eaton Fuller UltraShift and AutoShift transmissions)

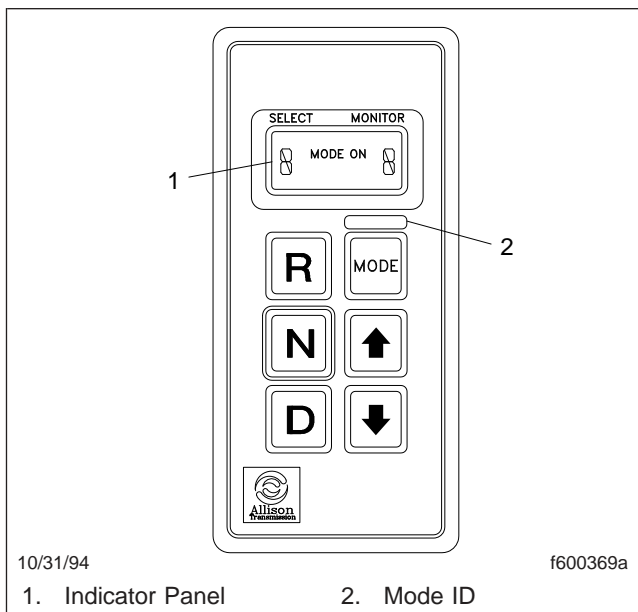

Fig. 5.22, Allison Push-Button Shift Selector

Cruise Control

⚠ WARNING

Do not use the cruise control system when driving conditions do not permit maintaining a constant speed, such as in heavy traffic or on roads that are winding, icy, snow-covered, slippery, or roads with a loose driving surface. Failure to follow this precaution could cause a collision or loss of vehicle control, possibly resulting in personal injury or property damage.

NOTICE

When the cruise control is engaged, do not attempt to shift gears without using the clutch pedal. Failure to follow this precaution will result in a temporarily uncontrolled increase in engine speed. Transmission damage and gear stripping could result.

IMPORTANT: On vehicles equipped with VORAD Collision Warning System with Smart-Cruise, see [Chapter 6](#) before operating the cruise control.

NOTE: If the vehicle is equipped with a Detroit multifunction control, setting the cruise control with the engine brake on will activate Descent Control Mode. Moving the lever to the top position will resume the set cruise speed. Moving the lever down to engage the engine brake after the cruise control has been set will activate Deceleration Mode. See "Descent Control and Deceleration Modes, Detroit™ Automated Transmissions" in this chapter.

The cruise control is operated by four buttons mounted in the left-hand button pod of the steering wheel. See [Fig. 5.7](#).

- ON/OFF Button—Press to turn cruise control on or off. When cruise control is on, a green telltale illuminates in the ICU. The speed memory will be retained until the cruise control is disabled with the ON/OFF button, or the ignition is turned off.

- **DEC/SET Button**—Press to set the cruise speed while the vehicle is traveling at the desired speed. Press and hold to decrease the set cruise speed.
 - **CNCL Button**—Press to pause the cruise control, while retaining the speed setting in memory. The cruise control can also be disengaged, while retaining the speed memory, by depressing the brake or clutch pedals.
 - **ACC/RES Button**—Press to resume the set speed. Press and hold to accelerate the set cruise speed.
1. To cruise at a particular speed:
 - 1.1 Press the ON/OFF button to turn cruise control on.
 - 1.2 Depress the accelerator pedal until the speedometer reaches the desired speed.

NOTE: Cruise control is cancelled if the brake or clutch pedal is depressed, or vehicle speed drops below the minimum cruise control speed.

- 1.3 Press the DEC/SET button to set the desired speed.

NOTE: The speed memory is lost whenever the ignition switch is turned to OFF, or cruise control is turned off.

2. To disengage the cruise control, do one of the following:
 - Press the CNCL button.
 - Depress the brake pedal.
 - Depress the clutch pedal (on a manual transmission only).
3. To resume a preselected cruise speed:
 - 3.1 Ensure cruise control is on.
 - 3.2 Press the ACC/RES button. Cruise will return to the last set speed.

NOTE: If vehicle speed drops below the minimum cruise control speed, cruise control will disengage. To resume to the preselected cruise speed, increase vehicle speed to above minimum cruise control speed and press the ACC/RES button.

4. To increase cruise speed, press the ACC/RES button until the vehicle accelerates to the desired speed.
5. To decrease cruise speed, press the DEC/SET button until the vehicle decelerates to the desired speed.

Run Smart Predictive Cruise™

Predictive Cruise Control (PCC) is an optional fuel savings application that adjusts vehicle speed predictively, based on the approaching road. Using 3D digital map technology and GPS, PCC evaluates the upcoming road grade about a mile in advance to determine the most fuel-efficient vehicle speed. Vehicles equipped with PCC have a sticker on the dash. See [Fig. 5.23](#).



Fig. 5.23, Run Smart Predictive Cruise Control Sticker

The 3D digital map database contains profile information for over 200,000 highway miles (322,000 km) in the 48 contiguous United States. PCC will vary the set cruise speed by up to 6% depending on the approaching road grade. If the engine brake is enabled, PCC will automatically engage the engine brake when actual vehicle speed exceeds the cruise set speed by 6%. This is different from conventional cruise control, which maintains the speed set by the driver.

WARNING

Apply the brakes and downshift as necessary when driving on downhill grades. PCC does not adequately control vehicle speed on steep downhill grades. Failure to use normal braking techniques when PCC is active could result in personal injury and vehicle damage.

IMPORTANT: PCC adjusts the vehicle set speed to achieve maximum fuel economy, but it does

Driver Controls

not account for traffic flows or surrounding vehicles.

Driver interaction with PCC is the same as conventional cruise control, using the standard cruise control buttons. In the event of a problem with PCC, or when driving on a road with no profile information available, the system reverts to conventional cruise control.

Cruise Control ("CC") Limiter

On vehicles equipped with a CC Limiter (or CC Band) switch (see [Fig. 5.24](#) or [Fig. 5.25](#)), the cruise control limiter allows the vehicle to exceed the set cruise control speed before engine braking is applied. The CC limiter switch provides more flexibility to the existing cruise control limit function, allowing the driver to tune the cruise function to better suit driving preferences and conditions. To select a limit, use the three-position CC Limiter switch on the dash. See [Table 5.1](#) for switch settings.

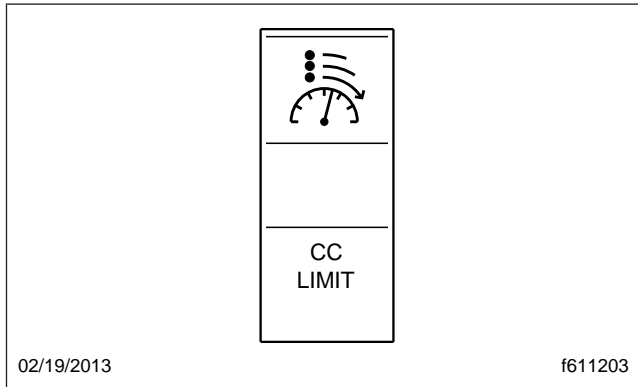

Fig. 5.24, CC Limiter Switch

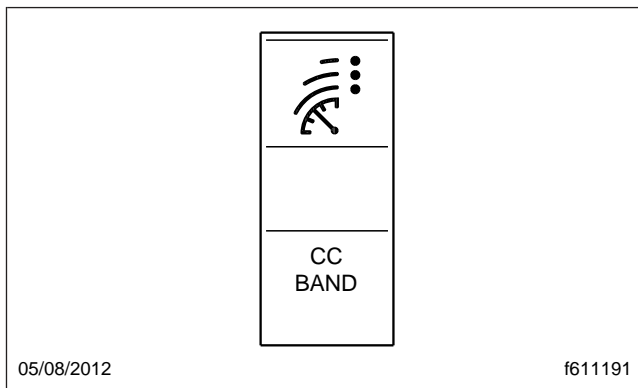

Fig. 5.25, CC Band Switch

| CC Limiter Switch Settings | |
|----------------------------|-----------------------------|
| Position | Approximate Overrun Setting |
| Top in | 3 mph (5 km/h) |
| Middle | 6 mph (9 km/h) |
| Bottom in | Unlimited |

Table 5.1, CC Limiter Switch Settings

Descent Control and Deceleration Modes, Detroit™ Automated Transmissions

On vehicles equipped with a Detroit multifunction control ([Fig. 5.26](#)), the functions of the lever positions for engine brake control change when cruise control is set. Two distinct modes can be activated:

- **Descent Control Mode**—engine braking keeps the speed below cruise set speed; throttle is not automatically applied.
- **Deceleration Mode**—engine braking activates to reduce vehicle speed (with no lower limit) at a constant rate.

Descent Control Mode

Descent Control Mode keeps the vehicle speed below the set cruise speed on a downhill.

To activate Descent Control Mode, set the cruise control speed with the engine brake on ([Fig. 5.26](#), positions 1, 2, or 3). In this mode, all three levels of engine braking will be employed to keep the speed below the set cruise speed. This mode will not keep the speed above the lower limit of the set speed, so it is possible to eventually coast to a stop, unless the lever is moved to "engine brake off" (position 0), or throttle is applied. After throttle application, the Descent Control Mode is resumed.

Moving the lever to "engine brake off" (position 0) cancels Descent Control Mode and resumes cruise speed. To reactivate Descent Control Mode, reset the cruise control speed with the lever in position 1, 2, or 3.

Deceleration Mode

Deceleration Mode reduces the vehicle speed at a constant rate.

With the cruise control speed set, activate Deceleration Mode by moving the lever to engine brake on

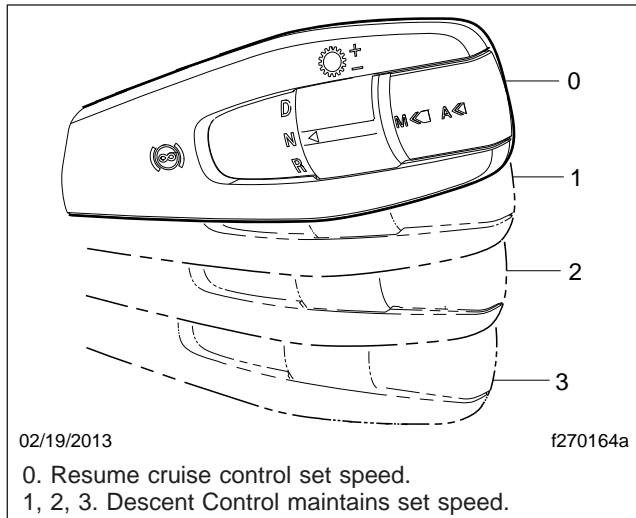

Fig. 5.26, Descent Control Mode Positions, Detroit Multifunction Control

(**Fig. 5.27**, position 1, 2, or 3). This mode engages one of the engine brake levels, depending on the lever position. The vehicle will decelerate at a constant rate until the vehicle comes to a stop, unless throttle applied to override the deceleration, or the lever is moved to "engine brake off" (position 0).

Moving the lever to position 0 resumes the previously set cruise control speed.

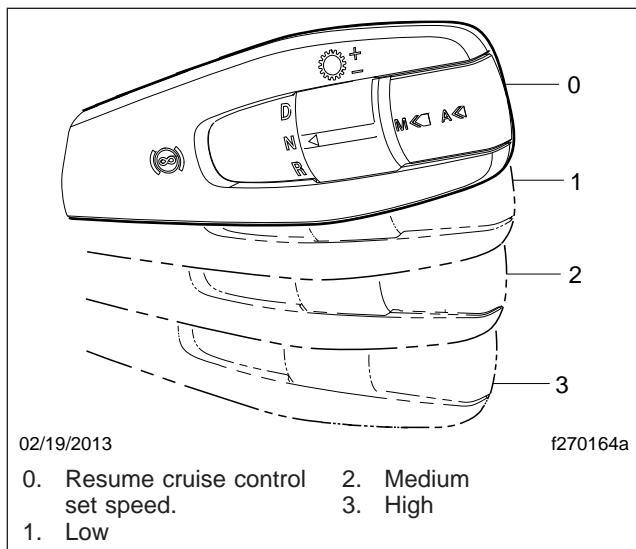

Fig. 5.27, Deceleration Mode Positions, Detroit Multifunction Control

Dash-Mounted Brake Controls

NOTE: See **Chapter 13** for detailed information about brake systems.

Parking Brake Control Valve

NOTICE

Do not step on the service brake pedal while the parking brakes are applied. To do so can cause damage to the brake mechanisms.

The yellow diamond-shaped knob operates the parking brake valve. See **Fig. 5.28**. Pull the knob out to apply both the tractor and the trailer spring parking brakes. Push the knob in to release the tractor spring parking brakes. Before the spring parking brakes can be released, the air pressure in either air brake system must be at least 65 psi (447 kPa).

If the trailer is not equipped with spring parking brakes, pull the parking brake valve out to apply the tractor parking brakes and the trailer service brakes.

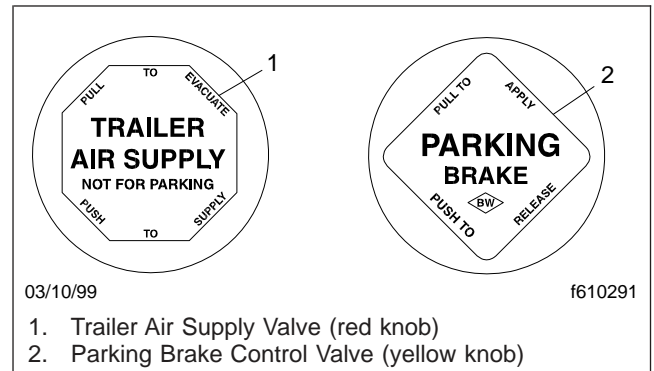

Fig. 5.28, Brake Valve Control Knobs

Trailer Air Supply Valve

The red octagonal-shaped knob operates the trailer air supply valve, which charges the trailer air supply system and releases the trailer spring parking brakes. See **Fig. 5.28**.

After the vehicle and its air hoses are connected to a trailer and the pressure in the air system is at least 65 psi (447 kPa), push the trailer air supply valve knob in (and leave it in) to charge the trailer air supply system and release the trailer spring parking brakes. Pull the trailer air supply valve out before

Driver Controls

disconnecting a trailer or when operating a vehicle without a trailer.

Trailer Brake Lever

The trailer brake lever is used to apply the trailer service brakes without applying the truck or tractor service brakes. It is usually mounted on the right-hand control panel. See [Fig. 5.29](#). The valve can be partially or fully applied, but in any partially on position it will be overridden by a full application of the service brake pedal. Move the lever down to apply the trailer brakes; move the lever up to release the trailer brakes. The lever will automatically return to the up position when it is released.

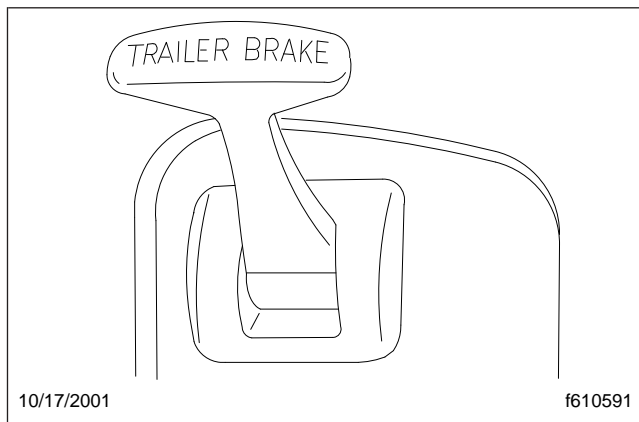

Fig. 5.29, Trailer Brake Lever

Antilock Braking System

The Meritor™ WABCO® Antilock Braking System (ABS) passively monitors vehicle wheel speed at all times, and controls wheel speed during emergency stops or wheel lock situations.

During emergency or reduced-traction stops, fully depress the brake pedal until the vehicle comes to a safe stop. *Do not pump the brake pedal.* With the brake pedal fully depressed, the ABS will control all wheels to provide steering control and a reduced braking distance.

The ABS is designed to communicate with a trailer ABS, if they are compatible. Compatibility will result in the illumination of the trailer ABS lamp during vehicle start-up and fault detection. The trailer ABS lamp will not illuminate unless a compatible trailer is connected to the tractor.

Vehicles with ABS may have Automatic Traction Control (ATC). On these vehicles, the ATC system automatically limits wheel spin during reduced-traction situations. In normal braking applications, the standard air brake system is in effect.

ATC includes a deep snow and mud option to increase available traction on extra-soft surfaces like snow, mud, or gravel. A switch labeled ATC will be located on the dash. See [Fig. 5.30](#). Press the switch to temporarily allow more drive wheel spin. The activation of the deep snow and mud option is indicated by a flashing WHEEL SPIN lamp. Press the switch again to cycle the system back to normal operation.

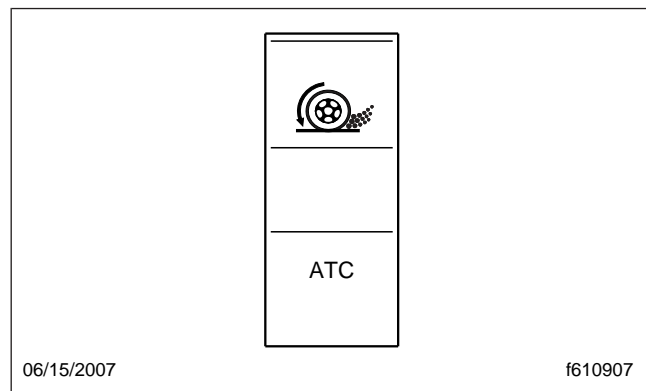

Fig. 5.30, ATC Switch

NOTICE

The deep snow and mud option is intended to be used under specific slippery conditions that require momentary increased wheel spin. Using this option for an extended period of time may damage the brake system.

Windshield Wiper/Washer Controls

The multifunction turn signal lever is attached to the left-hand side of the steering column, just below the steering wheel. See [Fig. 5.8](#).

NOTICE

Do not attempt to manually move the windshield wiper arms. Wiper motor damage will occur if the arms are forcibly moved.

The wipers are operated by a rotary switch in the wiper control dial, which is on the end of the turn signal lever. There are five intermittent settings, marked on the dial by lines of increasing length, and two steady speed settings: LO and HI.

Turn the wipers on by rotating the control dial counterclockwise. Rotate the control dial further to increase the speed of the wipers through the various intermittent settings, then to LO and HI.

Rotate the control dial clockwise to slow the wipers down. Rotate the control dial clockwise as far as it will go to turn the wipers off.

The windshield washer button is located at the end of the turn signal lever. Momentarily press the windshield washer button to initiate a single wipe without activating the washer pump. The wipers will swipe one full cycle and return to the inactive position.

To operate the windshield washers, press and hold the button in. After a short delay, the washer will pump windshield washer fluid onto the windshield for as long as the washer button is pressed. The windshield wipers will turn on at low speed while the washer button is pressed. After the button is released, the wipers will continue to operate for one to several wipe cycles, depending on how long the wash button was pressed initially.

Suspension/Trailer Connection Controls

Air Suspension Dump Control Switch

NOTICE

Do not operate the vehicle over uneven ground such as ramps, speed bumps, curbs, etc. with the air springs deflated. Doing this may lead to air bag separation from the piston, preventing the suspension air springs from re-inflating.

The air suspension height control switch may be used to aid in connecting or disconnecting from a trailer. See [Fig. 5.15](#). When the switch is set to LOWER, the air-suspension dump valve deflates the air springs to lower the rear of the vehicle. In the AUTO position, the automatic ride-control valves operate for normal driving.

NOTICE



Never exhaust air from the suspension while driving. When the air is exhausted, the suspension will not absorb road shocks, and components may be damaged.

A red LED in the switch is illuminated when the suspension is deflated.

ECAS Remote Control Unit (ECAS only)

Some vehicles equipped with Electronically Controlled Air Suspension (ECAS) have a remote control unit to lower and raise the rear suspension. See [Table 5.2](#) for keys and functions.

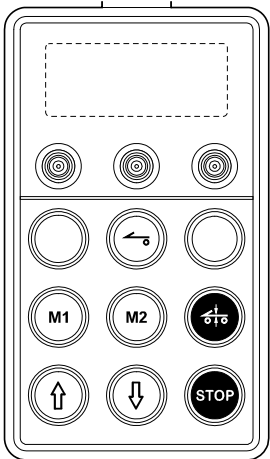
If the suspension is outside normal ride height (amber lamp on), the ECAS system will automatically return the suspension to normal ride height when vehicle speed reaches or exceeds a set speed (usually set to 5 mph).

| ECAS Remote Control Keys and Functions | |
|---|---|
|  | |
| 08/16/2013 | f611211 |
| Key | Function |
|  | Remote Control On/Off. The middle light will remain lit while the remote is active. |

Driver Controls





| ECAS Remote Control Keys and Functions | |
|---|--|
|  | Memory keys. Pressing the Stop key and a memory key simultaneously will store the current height. Once stored, pressing the key will adjust the vehicle to the stored height. |
|  | Normal height key. This key will return the vehicle to normal ride height. |
|  | Lift and lower keys. These keys will raise or lower the rear suspension height. |
|  | The Stop key. Pressing the Stop key will interrupt and stop all adjustments being made by the remote control. When the key is off, holding the Stop key for 2 seconds will cancel the 1 hour Standby mode. |

Table 5.2, ECAS Remote Control Keys and Functions

ECAS Standby Mode

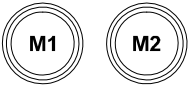
Once the key is turned off, the ECAS will enter Standby Mode, remaining powered and adjusting to level and load changes for 1 hour. To cancel Standby mode, hold the STOP button on the remote for 2 seconds.

Fifth Wheel Slide Control Switch

NOTICE

Do not activate the fifth wheel slide control valve while the vehicle is in motion. To do so could cause damage to the fifth wheel member, the kingpin, the cab or trailer, and ultimately to the drivetrain.

The fifth wheel air slide valve allows repositioning of the sliding fifth wheel from inside the cab. See [Fig. 5.15](#). Move the air slide control valve switch to the LOCK position to lock the fifth wheel to the baseplate. Move the switch to the UNLOCK position to unlock the fifth wheel slide mechanism, allowing changes to the total length of the tractor-trailer and changes to axle loads to comply with state or provincial laws.

For detailed operating instructions for fifth wheel slide, refer to [Chapter 18](#). A red indicator light illuminates whenever the fifth wheel slide is unlocked.

Trailer Auxiliary Switch

Trailers that are equipped with pneumatic brakes and used in North America or South America are generally equipped with power for the trailer lights. The connection is passed from the vehicle to the trailer via the primary receptacle, controlled by a dash switch.

Press the top of the switch to activate the trailer auxiliary function. Press the bottom of the switch to turn trailer auxiliary function off. See [Fig. 5.31](#).

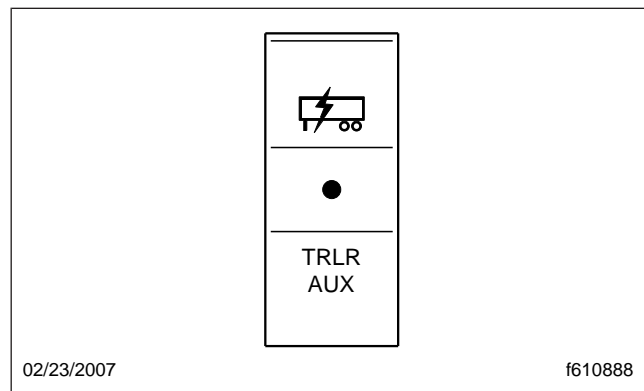

Fig. 5.31, Trailer Auxiliary Switch

Climate Controls

NOTE: See [Chapter 8](#) for detailed climate control panel operating instructions.

Cab Climate Control

The climate control panel allows you to control the heating, ventilating, defrosting, and air conditioning (A/C) functions. The cab climate control panel has three switches to control the functions of the cab temperature system; see [Fig. 5.32](#):

- fan switch with recirculation button
- temperature control switch with A/C button
- air selection switch (with bunk-override button on sleeper cab only)

The fan switch controls the fan speed, and forces fresh or recirculated air through the air outlets. To increase airflow, turn the switch clockwise to a higher number. To decrease airflow, turn the switch counter-clockwise to a lower number.

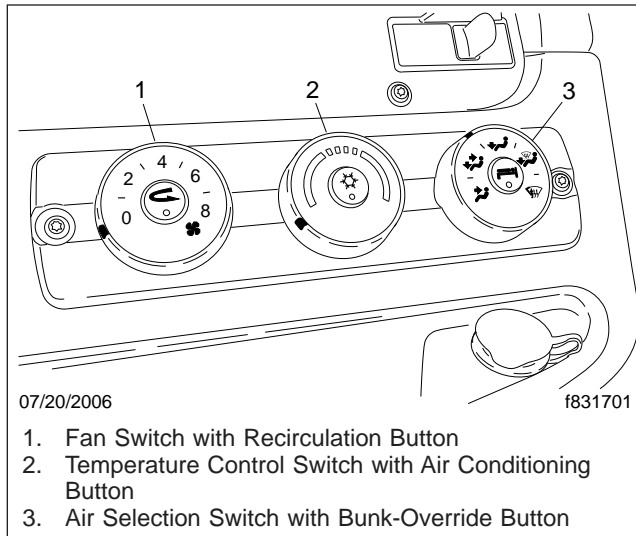

Fig. 5.32, Cab Climate Control Panel

Recirculation mode limits the amount of outside air that enters the cab. Press the recirculation button to prevent dusty or smoky air from entering the cab.

NOTE: To prevent the buildup of odors and/or oxygen depletion inside the cab, the system switches from full recirculation mode to partial recirculation mode after 20 minutes.

The temperature control switch is used to select the desired temperature. Turn the switch clockwise to the red area for warm air. Turn the switch counterclockwise to the blue area for cool air.

The A/C cools and dehumidifies the air inside the cab. Press the A/C button, located in the center of the temperature control switch, to turn the A/C on and off.

The air selection switch allows the control of air flow through the face outlets, the floor outlets, the defrost (windshield) outlets, or a combination of these outlets. See [Fig. 5.33](#).

Bunk-Override Button

The bunk-override button is located in the center of the cab air-selection switch (sleeper-cabs only). See [Fig. 5.33](#).

Press the bunk-override button to make the cab controls override the settings on the sleeper temperature control panel; the sleeper temperature will mimic the cab settings. An amber LED in the button is illumi-

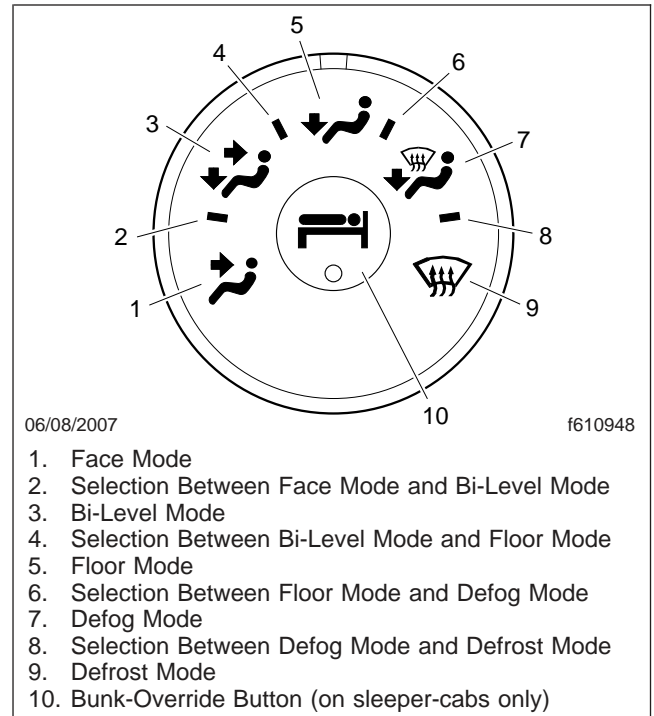

Fig. 5.33, Air Selection Switch With Bunk-Override Button

nated when the bunk-override mode is activated. When the override switch is not activated, the cab climate control panel can be adjusted without affecting the sleeper settings.

Sleeper Climate Control

The sleeper temperature can be controlled from the sleeper climate control panel or from the cab climate control panel if the bunk-override button is activated.

The fan switch controls the sleeper temperature fan speed. To increase airflow, turn the switch clockwise to a higher number. To decrease the airflow, turn the switch counterclockwise to a lower number. See [Fig. 5.34](#).

The temperature control switch is used to select the desired temperature in the sleeper. Turn the switch clockwise to the red area for warm air. Turn the switch counterclockwise to the blue area for cool air.

Press the button in the center of the temperature control switch to activate the A/C.

Driver Controls

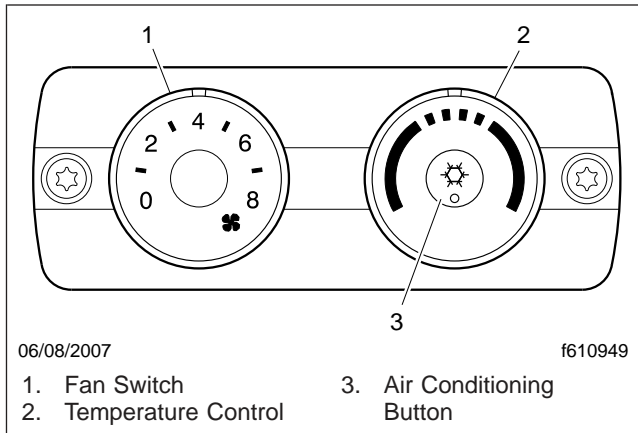

Fig. 5.34, Sleeper Climate Control Panel

Cancel bunk-override mode, if activated, by changing the sleeper fan speed or temperature setting. The system will then operate from the sleeper controls.

Seat Controls

NOTE: See [Chapter 7](#) for detailed information about seat controls and adjustments.

⚠ WARNING

Keep hands, tools, and other objects away from the scissor points under the seats. Failure to do so could cause personal injury.

The following is a description of adjustments that can be made to various seats. Not all seats have all of the adjustments listed below. See [Fig. 5.35](#).

- Backrest tilt
- Lumbar support
- Isolator
- Height adjustment
- Bottom cushion angle (fore-and-aft bottom cushion height)
- Fore-and-aft seat slide (seat track adjustment)
- Seat tilt
- Headrest adjustment

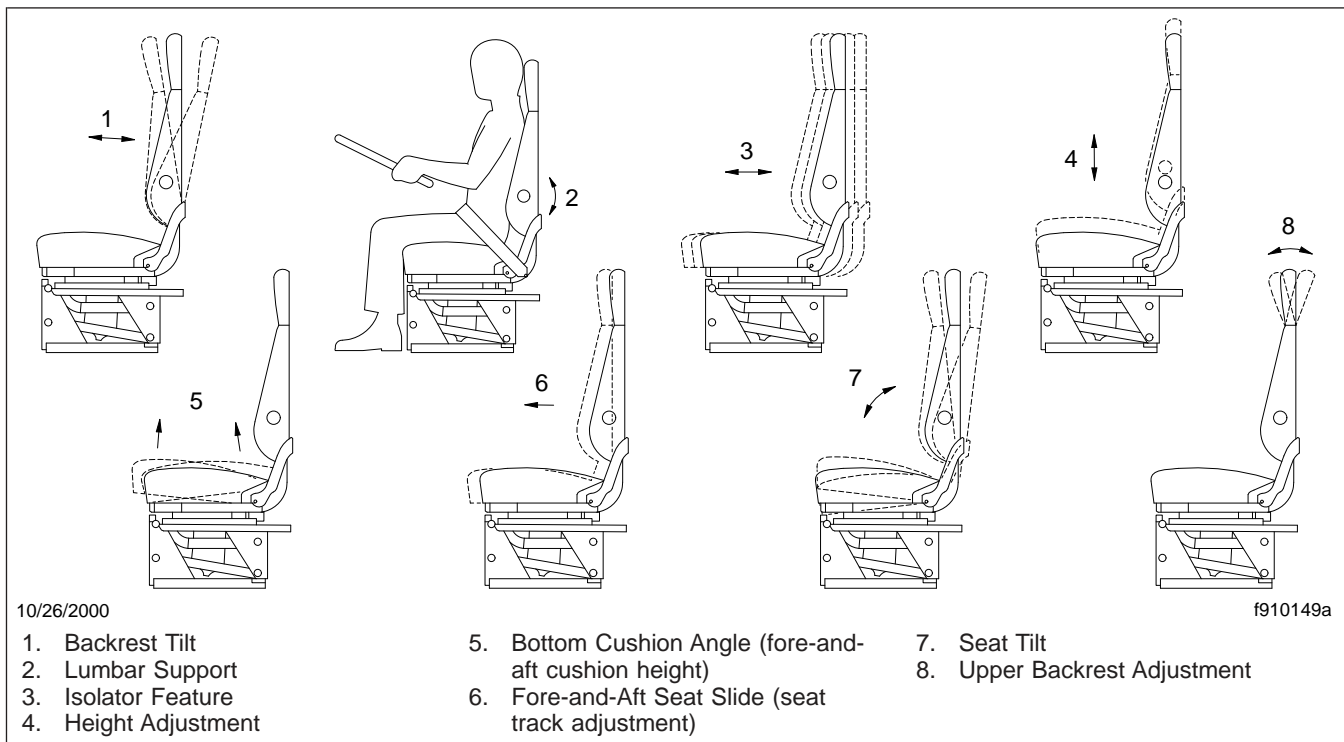

Fig. 5.35, General Seat Adjustments

Adjustable Steering Column Controls

To adjust the steering column, depress the foot pedal located below the steering column. See [Fig. 5.36](#). Tilt the steering column to the desired angle. Telescope the steering column closer or further away by pushing or pulling it. Release the foot pedal to lock the steering column in place.

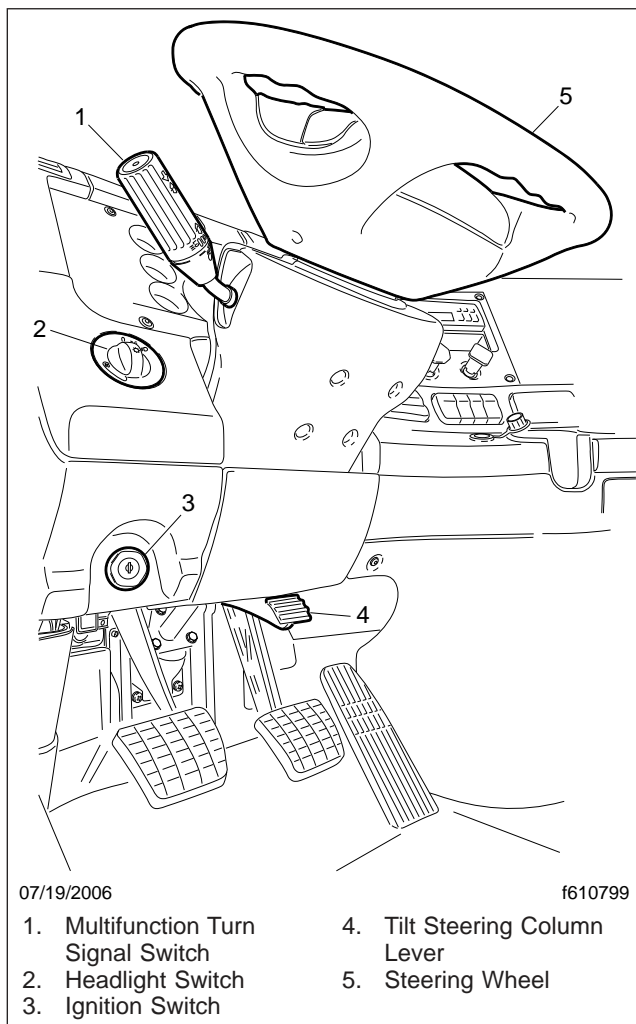

Fig. 5.36, Steering Column and Left Panel Controls

6

Driver Assistance Features

| | |
|--|------|
| VORAD VS-400 System | 6.1 |
| OnGuard™ Collision Safety System | 6.7 |
| Lane Departure Warning Controls | 6.10 |
| Roll Stability System | 6.11 |
| Enhanced Stability Control | 6.13 |

Driver Assistance Features

VORAD VS-400 System

WARNING

The VORAD VS-400 System is intended solely as an aid for an alert and conscientious professional driver. It is not intended to be relied upon to operate a vehicle. Use the system in conjunction with rearview mirrors and other instruments to safely operate the vehicle. Operate a vehicle equipped with the VS-400 System in the same safe manner as if the CWS were not present.

The VS-400 System is not a substitute for safe, normal driving procedures, nor will it compensate for any driver impairment such as drugs, alcohol, or fatigue.

The VS-400 System may provide little or no warning of hazards such as pedestrians, animals, oncoming vehicles, or cross traffic.

Failure to drive safely and use the system properly could result in personal injury and/or death and severe property damage.

The VORAD VS-400 system is an on-board radar system that monitors traffic conditions, warning the driver of potentially hazardous driving situations.

The collision warning system (CWS) tracks objects ahead of the vehicle, warning the driver with visual and audible indicators whenever following distances become unsafe.

SmartCruise® adjusts the vehicle's cruise speed in order to match the speed of traffic ahead, allowing the driver to maintain a safe following distance while cruise control is engaged.

The optional side object detection system warns of unsafe lane changes by detecting vehicles that may be difficult to see in adjacent lanes.

The VORAD VS-400 system performs in fog, rain, snow, dust, smoke, and darkness. The VS-400 system becomes active whenever the ignition key is switched to ON.

Driver Interface Unit

The driver interface unit (DIU) provides visual and audible alerts, along with system status information. The DIU also provides an interface for changing system settings. Menu selections are made by pressing

the up and down arrow buttons, and the OK button. See [Fig. 6.1](#).

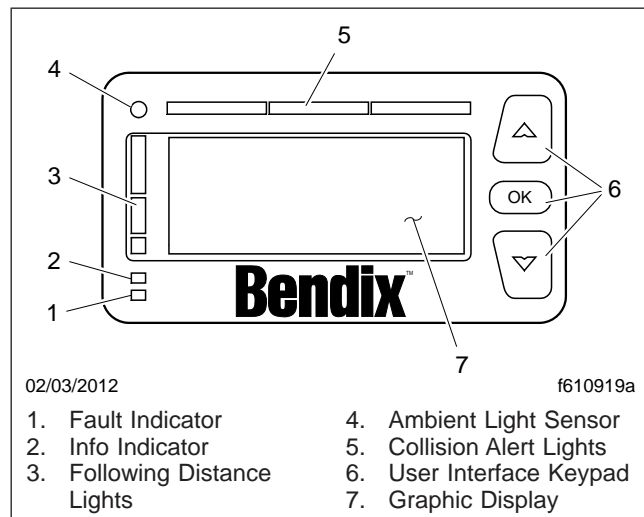

Fig. 6.1, Driver Interface Unit (DIU)

The following warning and indicator lights illuminate on the DIU:

- Red: illuminates with the collision alert
- Yellow: illuminates with 3-, 2-, and 1-second following distance alerts
- Orange: illuminates when a system failure occurs
- Blue: illuminates when information is available

Immediately after the ignition switch is turned to ON, the DIU initializes a self-test routine. During the initialization, the VORAD screen displays and all lamps illuminate for approximately three seconds, along with a power-up tone. When the initialization is complete, the DIU displays the VS-400 system configuration screen. See [Fig. 6.2](#).

Menu Selections

IMPORTANT: The display of a menu item is overridden whenever conditions require an alert or collision warning to be displayed.

After initialization, the menu screen is displayed. Scroll to the desired menu item by pressing an arrow button, then press the OK button to select the item. See [Fig. 6.3](#). If the driver does not make a selection within 30 seconds, or the vehicle begins to move, the DIU reverts to the system status display.

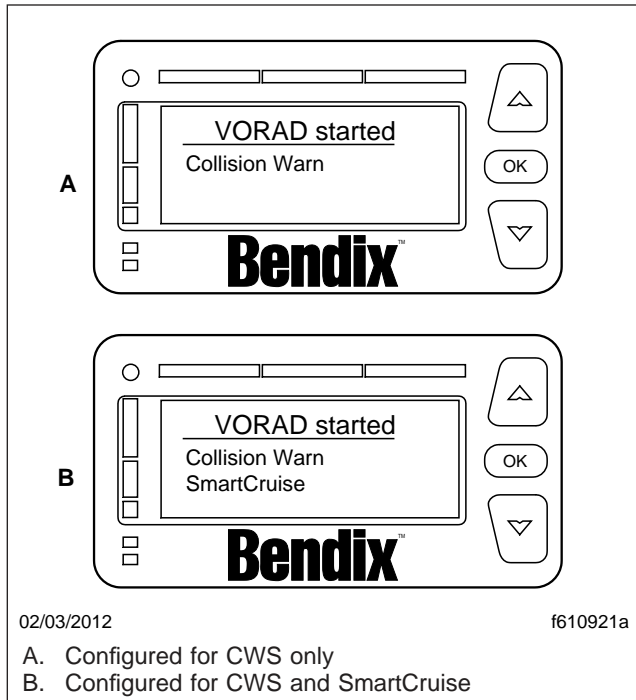

Fig. 6.2, System Configuration Screens

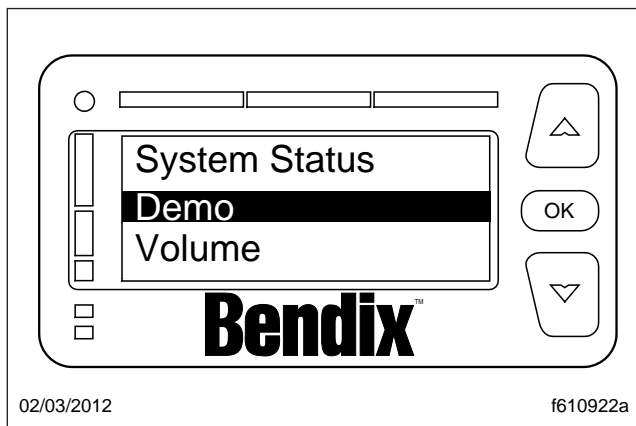

Fig. 6.3, Menu Screen

The display of any menu item is overridden whenever conditions require an alert or collision warning to be displayed.

Demo (vehicle must be stationary)

When the vehicle is stationary and Demo mode is selected, the DIU will demonstrate the meaning of all LED and screen displays, including alert messages and sound warnings. Scroll through the demo

screens by pressing the down arrow. Pressing any other key exits Demo mode.

Volume

The minimum adjustable volume is 50% of the maximum volume. If the DIU volume is not adjustable, the display screen shows a grayed bar graph whenever volume adjustment is selected. See Fig. 6.4. After each ignition switch cycle, the volume will default back to 100%.

NOTE: Headway and collision alert tones may be suppressed when the brake is applied if the system is configured to do so.

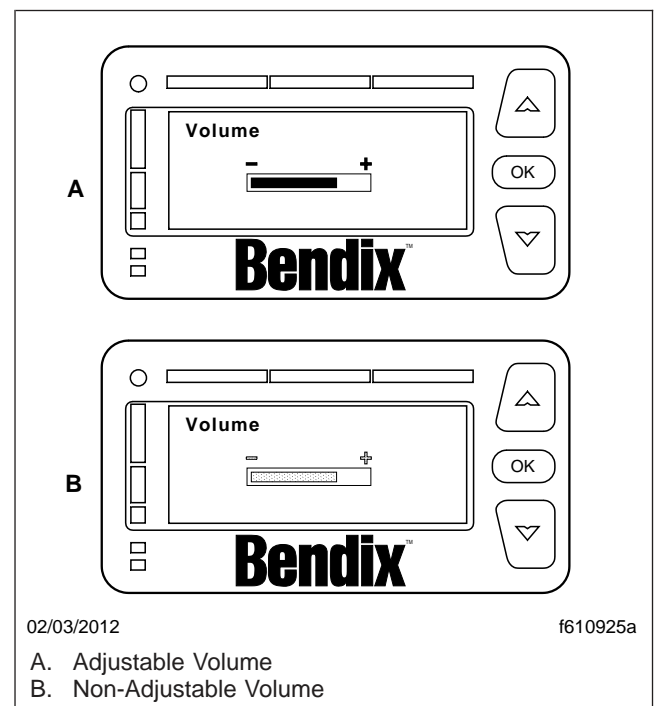

Fig. 6.4, Volume Screen

SmartCruise Headway Range

Headway range adjustment is only available with SmartCruise. Headway range is adjustable between 3.25 and 2.25 seconds. The headway range setting will default to 3.25 seconds after each ignition power cycle.

If headway range adjustment is disabled, only the **3.25 sec** screen is displayed. See Fig. 6.5 for the various headway range screens. Press the OK button to exit the menu.

Driver Assistance Features

NOTE: If the headway range is adjusted to three seconds or below and SmartCruise is active, the 3-second collision warning headway alert will not display. All other alerts are not suppressed.

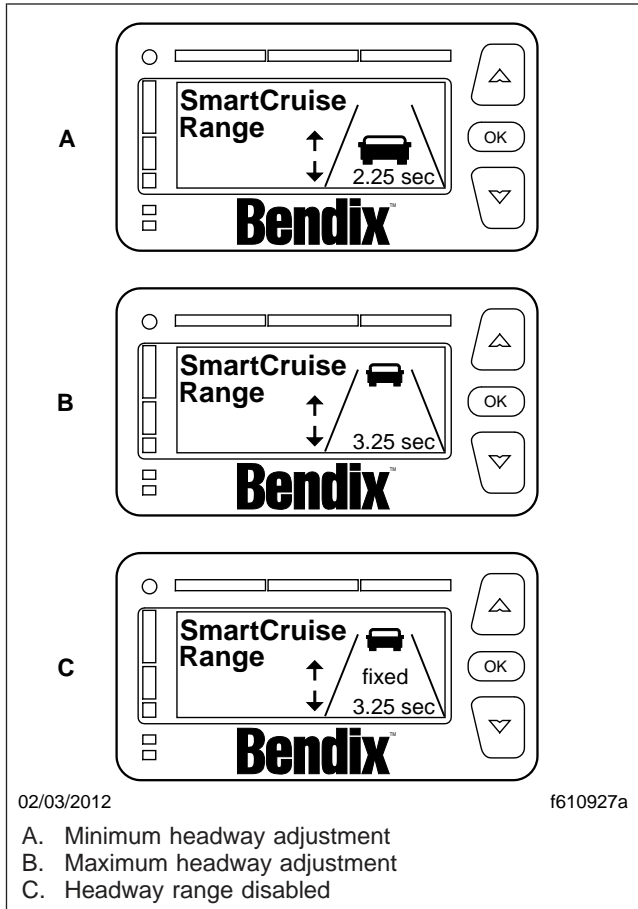

Fig. 6.5, Headway Range Screen

Brightness

Use the up and down arrows to change the DIU backlight and warning LED brightness. Press the OK button to exit the brightness screen.

The ambient light sensor reading determines if the DIU is in daytime or nighttime mode. Menu-adjusted brightness is applied only to the mode the DIU is in at the time of adjustment. The previous brightness settings are repeated after each ignition cycle. However, the graphic display and the warning LED brightness range are constrained such that they are always visible regardless of how low the brightness is

adjusted in all driving conditions. Press the OK button to exit the menu.

Unit Adjustment Screen

The unit adjustment screen allows the driver to select either km/h or mph units for display of SmartCruise set speed. Press OK to exit the mph selection screen.

System Status

System status shows the status of each system, indicating if the system is operating normally. If a system is not operating normally, the system displays **Failed** beside the system name. **Failed** indicates that a fault is preventing the system from operating and it cannot be used until the fault is corrected or acknowledged.

Depending on the VS-400 system installed, one of the screens shown in Fig. 6.6 will appear unless a system fault is active. Press OK to exit the system status menu.

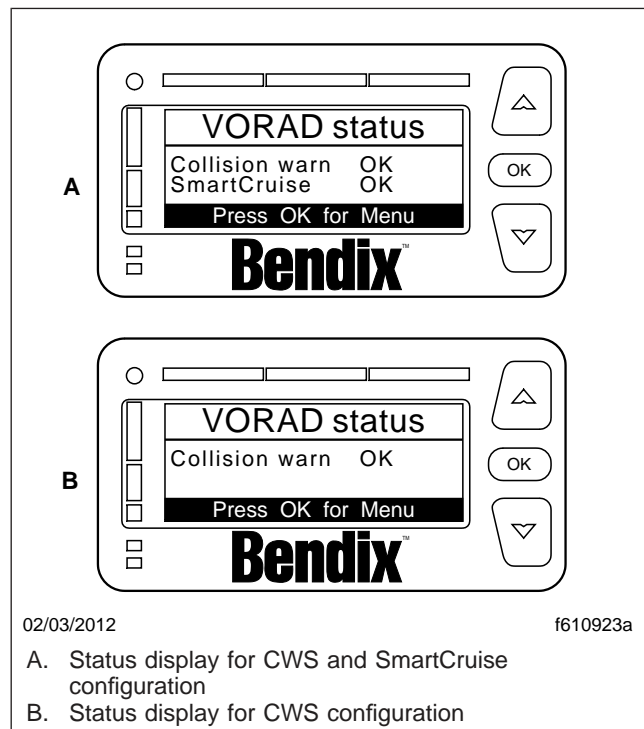

Fig. 6.6, System Status Screens

Diagnostics

The DIU displays fault codes currently active when this screen is selected and the vehicle is stationary.

See [Fig. 6.7](#). Contact an authorized Freightliner service center if fault codes display.

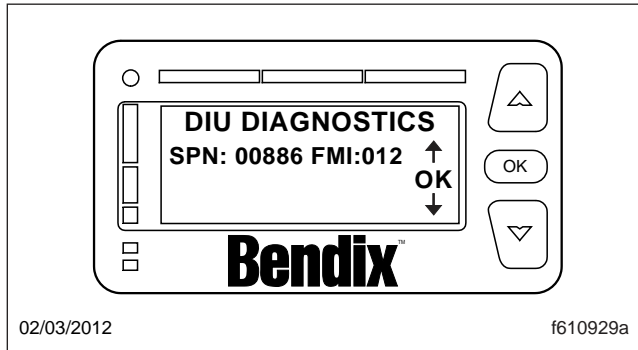

Fig. 6.7, DIU Diagnostic Screen

Collision Warning System

The CWS may require a warm-up period of up to one minute if the outside air temperature is below 32°F (0°C). The DIU will display a warm-up message until the system reaches operating temperature. See [Fig. 6.8](#).

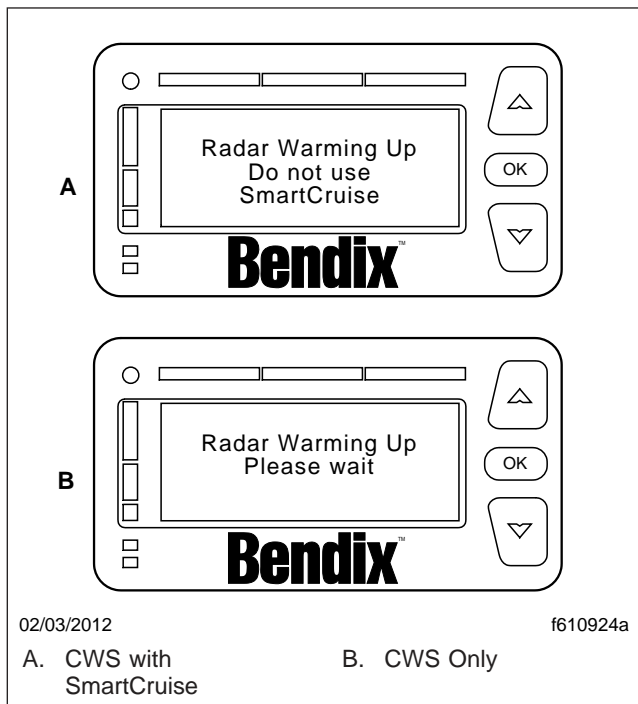

Fig. 6.8, CWS Warm-Up Screens

The alerts given by the VS-400 system are based on the distance to the object ahead, whenever vehicle speed is 10 mph (16 km/h) or faster. The VS-400 CWS identifies and tracks the nearest object in the lane of travel. This object is classified by the range, and assigned a message described under the following headings.

Object Detected

When a vehicle is detected in the same lane of travel within 350 ft (107 m) but farther than a 3-second following distance, the DIU will display **OBJECT DETECTED**. See [Fig. 6.9](#).

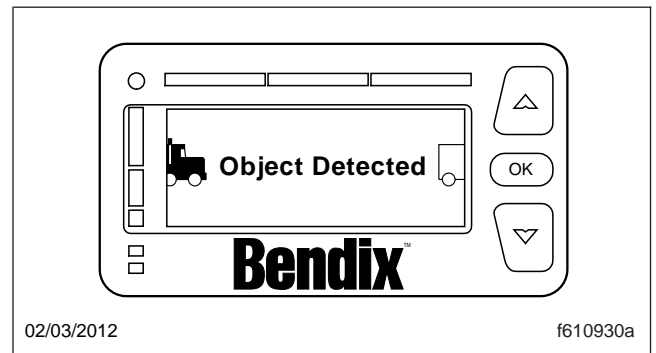

Fig. 6.9, Object Detected Alert

3-Second Headway Alert

When a vehicle is detected to be within a 3-second following distance, a single yellow indicator will illuminate and the DIU will display **3 seconds**. See [Fig. 6.10](#).

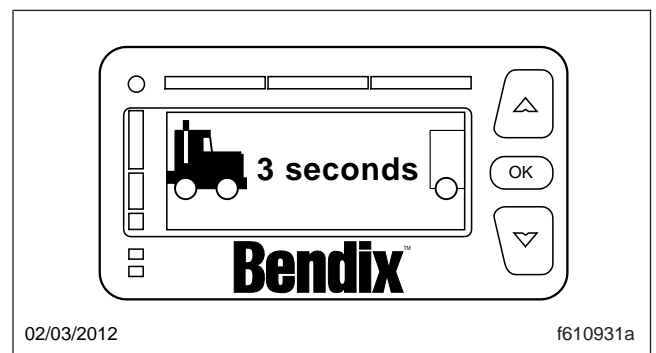

Fig. 6.10, 3-Second Alert

Driver Assistance Features

2-Second Headway Alert

When the following distance to the object ahead in the same lane of travel decreases to within two seconds, a second yellow indicator will illuminate, the DIU will display **2 seconds**, and a single tone will sound. See [Fig. 6.11](#).

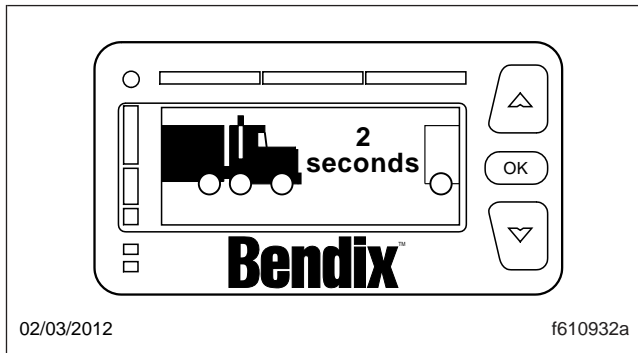

Fig. 6.11, 2-Second Alert

1-Second Headway Alert

When the following distance to the object ahead in the same lane of travel decreases to within one second, a third yellow indicator will illuminate, the DIU will display **1 sec**, and two tones will sound. See [Fig. 6.12](#).

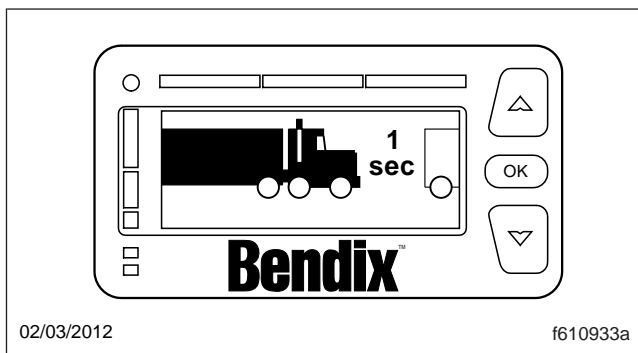

Fig. 6.12, 1-Second Alert

Collision Alert: 1/2-Second Headway

When the following distance to the object ahead in the same lane of travel decreases to 0.5 second, the red indicators all illuminate across of the DIU, the DIU will display **COLLISION ALERT**, and a tone will sound repeatedly. See [Fig. 6.13](#).

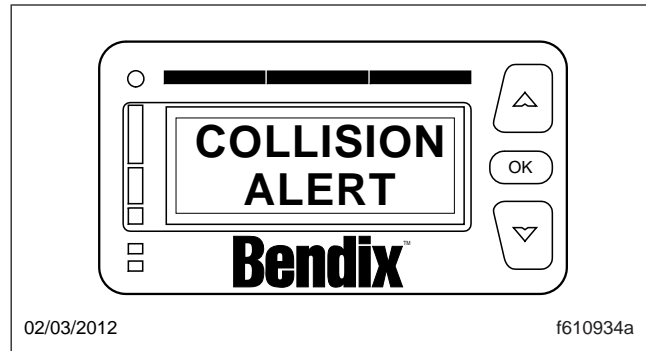

Fig. 6.13, Collision Alert

SmartCruise

When approaching slower moving traffic with the vehicle's cruise control engaged, SmartCruise adapts the engine cruise speed to that of the closest vehicle ahead, allowing the vehicle to maintain a safe following distance without disengaging the cruise control. The DIU will display the SmartCruise status screen indicating the vehicle's current set cruise speed.

Once the speed of traffic ahead increases beyond the adapted engine cruise speed, the original cruise control set speed re-engages.

When SmartCruise is engaged, depressing the accelerator pedal will override the SmartCruise and will cause the vehicle to accelerate. Depressing the brake or clutch pedals will deactivate SmartCruise.

When approaching a slow moving or stopped vehicle ahead, SmartCruise will attempt to maintain the minimum following distance by reducing the engine cruise speed and engaging the engine brake, if necessary. If SmartCruise is unable to maintain the minimum following distance, the driver will be alerted by the CWS headway alerts until the driver takes control or conditions clear.

Side Object Detection

The optional side object detection system may be installed on one or both sides of the vehicle. The radar sensor(s) are located on the side of the vehicle, while the sensor display unit is mounted on the A-pillar. See [Fig. 6.14](#).

The side sensor display unit uses two lights to display the status of the side sensor(s). The yellow light indicates the system is active, but no objects are detected. The red light indicates that the side sensor detects an object. If the vehicles turn signal is active

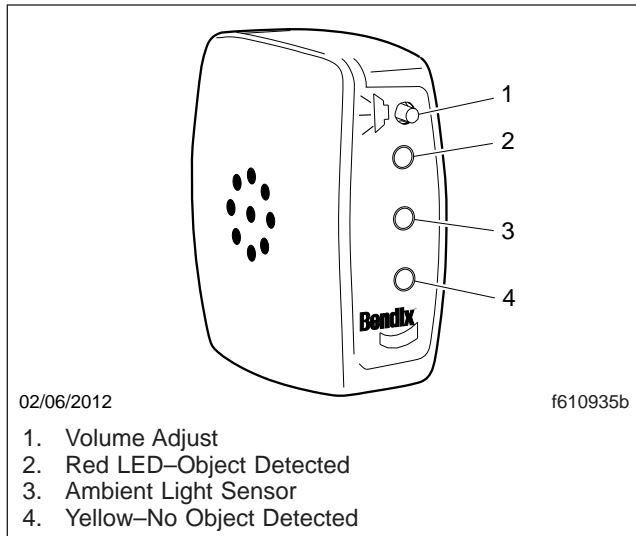

Fig. 6.14, Side Sensor Display Unit

and the sensor detects an object alongside the vehicle, an audible warning tone will sound.

Special Road Situations

Certain road situations may affect the system's ability to detect objects. These situations include the effects of curves, dips, and hills which can provide an unexpected result.

NOTE: A warning may sound when an object is detected in front of the vehicle even though the driver intends to turn away or stop before reaching the object.

- When an object is detected in a very sharp right- or left-hand turn, the audible alarm will not sound.
- When approaching a curve, alarms may sound and lights illuminate, because of an object off the road directly in line with your vehicle. This will not occur when the brakes are applied.
- When approaching a roadway descending to a lower elevation, elevated obstacles such as overpasses and overhead signs may be detected.
- Vehicles cannot be detected on the other side of a hill. An alarm will not sound until the object is within the antenna assembly's field of view.

- On approaching a steep hill, objects above the beam cannot be detected. Generally, the beam hitting the road surface does not cause an alarm.
- The side sensor only detects objects within its field of view, next to the tractor. A vehicle behind the field of view will not be detected.
- The side sensor range is set to detect average-sized vehicles 2 to 10 feet (0.5 to 3 meters) away in the adjacent lane.
- The radar beam will detect near range cut-ins of approximately 30 feet (9 meters) or less, depending on the angle of entrance into the lane in front of your vehicle.
- A continuous fixed object on the right side of the vehicle such as a guard rail, wall, tunnel, or bridge may cause the side sensor alert light to stay on.

! WARNING

Heavy rain or water spray at the side sensor may cause both the yellow and red lights on the side sensor display to illuminate at the same time. Under these conditions the system is temporarily unable to provide adequate warnings.

Failure to drive safely and use the system properly could result in personal injury and/or death and severe property damage.

Maintenance

Keep the antenna and side sensor free of buildup of mud, dirt, ice, or other debris that might reduce the system's range.

Failure Display Mode/Fault Codes

The VS-400 performs internal diagnostics at power-up, then continuously monitors system components thereafter.

If a failure is detected, depending on what features are affected, the DIU displays a screen similar to **Fig. 6.15**, blinks the orange fault light, and sounds a tone. Press the OK button to acknowledge the fault.

After the fault has been acknowledged, the DIU will attempt to return to normal operations. The orange LED is continuously illuminated while the fault persists. If the fault disappears, the VS-400 transmits a

Driver Assistance Features

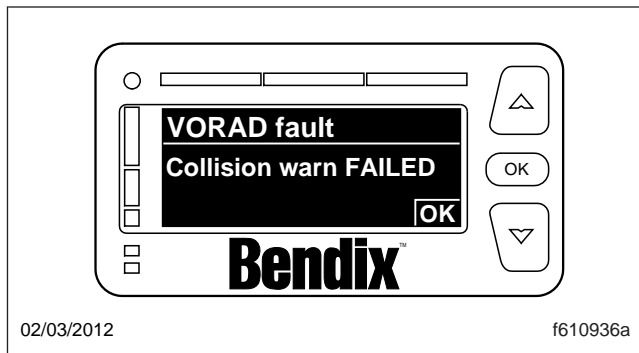

Fig. 6.15, VORAD Fault Display

message to indicate that the fault status has changed to a previously active fault.

In the event the CWS antenna becomes blocked while the vehicle is moving (e.g., snow, mud, ice, tampering, etc.), the system sounds a tone and displays the fault screen shown in Fig. 6.16.

Contact an authorized Freightliner dealer to review and clear previously active fault codes.

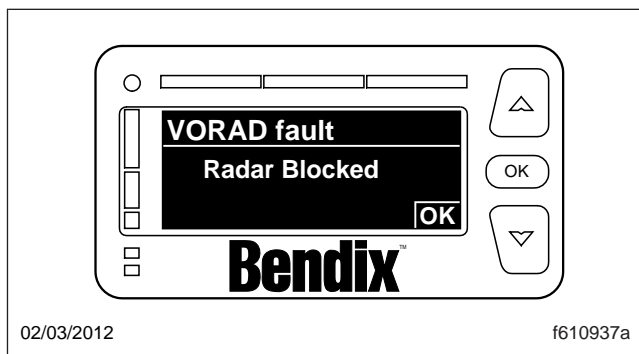

Fig. 6.16, Antenna Blocked Display

OnGuard™ Collision Safety System

Meritor WABCO OnGuard is a forward-looking radar-based adaptive cruise control and collision safety system with active braking. The system includes a collision warning system (CWS), adaptive cruise control (ACC) with active braking, and a collision mitigation system (CMS).

The system performs in fog, rain, snow, dust, smoke, and darkness. To be detected, objects must be within the radar field of view and provide a surface area that can reflect the radar.

The front-looking antenna assembly transmits radar signals to, and receives them back from, objects ahead of the vehicle. This allows the determination of the distance, speed, and angle of the object ahead. The system uses this information to warn the driver of potentially dangerous situations.

WARNING

The Meritor WABCO OnGuard™ Collision Safety System is intended solely as an aid for an alert and conscientious professional driver. It is not intended to be relied upon to operate a vehicle. Use the system in conjunction with rearview mirrors and other instruments to safely operate the vehicle. Operate a vehicle equipped with the OnGuard in the same safe manner as if the CWS were not present.

The OnGuard Collision Safety System is not a substitute for safe, normal driving procedures, nor will it compensate for any driver impairment such as drugs, alcohol, or fatigue.

The OnGuard Collision Safety System may provide little or no warning of hazards such as pedestrians, animals, oncoming vehicles, or cross traffic.

Failure to drive safely and use the system properly could result in personal injury and/or death and severe property damage.

OnGuard Display Unit

The OnGuard system controls are located in the display unit. The display provides visual and audible warnings and messages, as well as verification of correct system operation and faults. Menu selections are made by pressing the up and down arrows, and the MODE button. See Fig. 6.17.

The display includes:

- an internal speaker
- a graphic display
- buttons to scroll and select options

Collision Warning System (CWS)

The CWS generates audible and visual alerts when the vehicle's following distance may result in a collision. The CWS provides only a warning, and will not control vehicle speed.

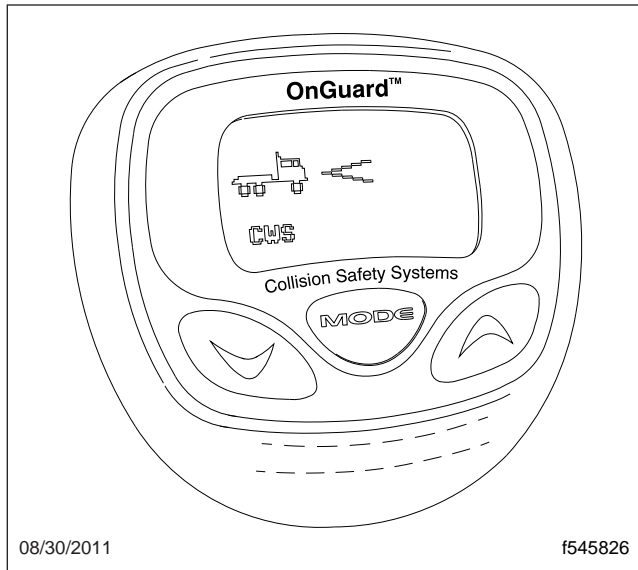

Fig. 6.17, OnGuard Display Unit

The CWS cannot be disengaged or turned off, and is always active at vehicle speeds above 15 mph (25 km/h).

Standby

When no object is detected, the display shows that the CWS is on and the radar is searching. See [Fig. 6.17](#).

Object Detected

When an object is detected in the lane ahead, the display shows that the CWS is on and the radar is tracking an object at the speed shown. See [Fig. 6.18](#).

If the following distance between the vehicle and the object is too close, the CWS will emit an audible alert and the display background will turn yellow. The alert will end when vehicle speed drops below the object speed and the following distance is increased.

Collision Warning

If the object is traveling slower than the driver's vehicle, the CWS warns of an impending collision by emitting an urgent audible alert and displaying the collision warning symbol with a red background. See [Fig. 6.19](#).

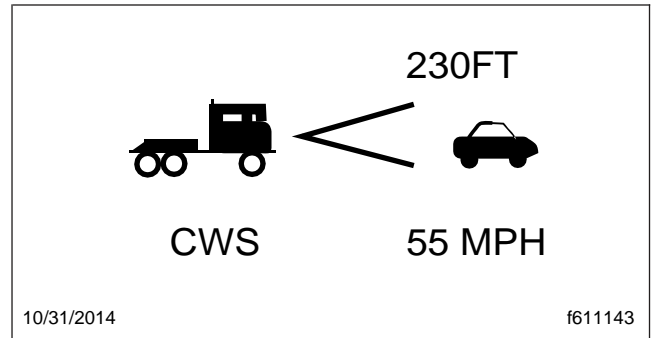

Fig. 6.18, CWS Object Detected

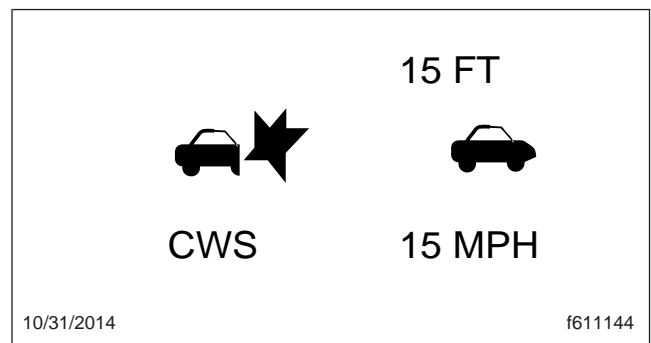

Fig. 6.19, CWS Collision Warning

Adaptive Cruise Control (ACC)

ACC is a radar-based system that works in conjunction with conventional cruise control to maintain the set cruise speed when no vehicle is being tracked, and maintains a minimum following distance when an object is being tracked. The minimum following distance is maintained by automatically decelerating the vehicle using throttle, engine, and service brakes without driver intervention. When the object is no longer being tracked, the set cruise control speed resumes automatically.

Standby

When no object is detected, OnGuard ACC operates similarly to conventional cruise control. The cruise control set speed is shown on the OnGuard display unit. See [Fig. 6.20](#).

Object Detected

When an object is detected in the lane ahead, the display shows that ACC is on and the radar is tracking an object at the speed shown. See [Fig. 6.21](#).

Driver Assistance Features

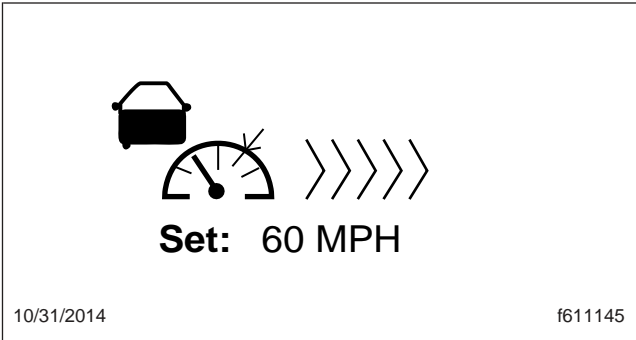

Fig. 6.20, ACC Standby

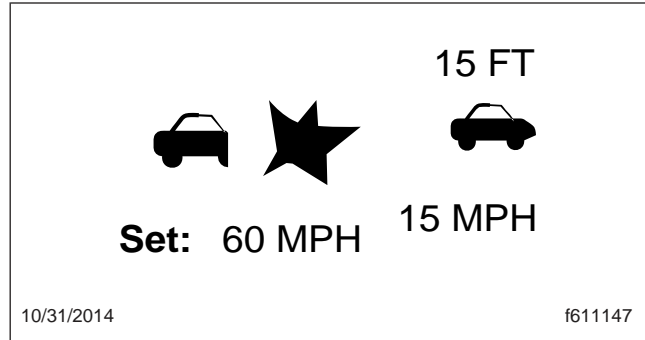

Fig. 6.22, ACC Collision Warning

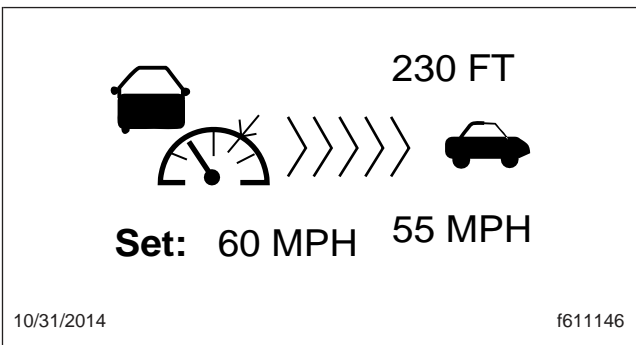

Fig. 6.21, ACC Object Detected

If the driver uses the accelerator pedal to override the cruise control and approach a vehicle too closely, the ACC will emit an audible alert and the display background will turn yellow. The alert will end when vehicle speed drops below the object's speed and the following distance is increased.

NOTE: The following distance alert does not operate at speeds below 15 mph (25 km/h).

Collision Warning

If the object is traveling more slowly than the driver's vehicle, the CWS warns of an impending collision by emitting an urgent audible alert and displaying the collision warning symbol with a red background. See [Fig. 6.22](#).

The braking control will activate and slow the vehicle. The driver must also initiate braking.

Collision Mitigation System (CMS)

The CMS provides the driver with audible and visual alerts when the vehicle's following distance could result in a rear-end collision. If a potential rear-end

collision is developing and the driver does decelerate the vehicle, OnGuard's active braking automatically applies the engine and service brakes to provide braking power. The active braking application is intended only to provide early braking as the driver is recognizing and reacting to the situation.

IMPORTANT: CMS and active braking are not operational at vehicle speeds below 15 mph (25 km/h).

Error Screens

IMPORTANT: The OnGuard collision safety system is not operational when an error screen is displayed.

If a system fault is detected, the OnGuard display unit will immediately display an error screen like the one shown in [Fig. 6.23](#). The first error code transmitted will be displayed first; additional faults (if any) can be viewed using the up or down buttons. The display does not show stored fault codes.

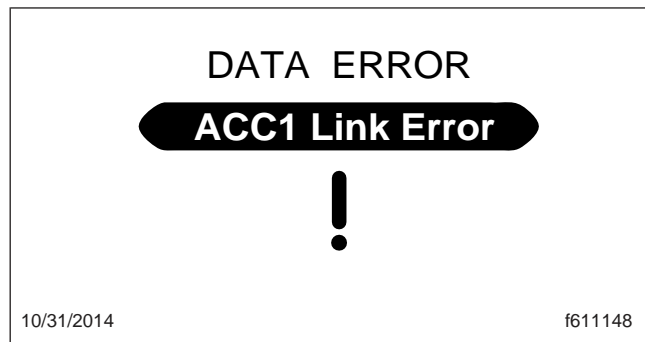

Fig. 6.23, OnGuard Error Screen

If a fault occurs or OnGuard fails to properly track a vehicle, take the vehicle in for service as soon as possible. Standard cruise control will not function with an active OnGuard system fault.

Refer to the OnGuard Collision Safety System Maintenance Manual MM-0951 for a full list of faults (www.Meritor.WABCO.com).

IMPORTANT: If the system fails to track an object, look for signs of damage to the radar assembly.

Additional Features

Press the MODE button to access the OnGuard display unit additional features from the CWS or ACC main operating screen. Press the up and down arrows to scroll through each menu, then press the MODE button to select the value to be changed. In edit mode, press the up or down arrows to change a value setting, then press the MODE button to save the setting. Pressing MODE in each feature screen advances the display to the next feature.

The Display Control menu allows adjustment of the alarm volume, LCD brightness, LCD contrast, and U.S./metric unit conversion. See [Fig. 6.24](#).

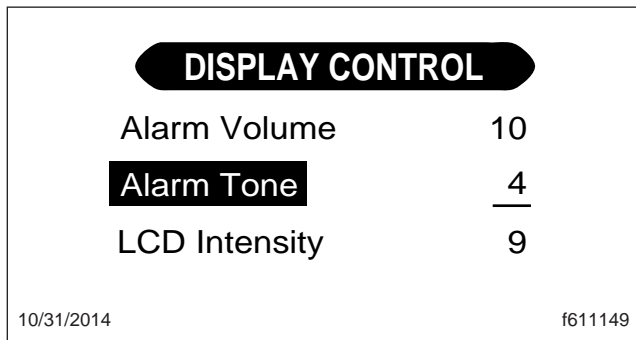

| DISPLAY CONTROL | |
|-----------------|----------|
| Alarm Volume | 10 |
| Alarm Tone | <u>4</u> |
| LCD Intensity | 9 |

10/31/2014 f611149

Fig. 6.24, Display Control Menu

The component test menu provides verification of system component operation and acts as a valuable OnGuard system diagnostic tool. The header will display either **COMPONENT TEST** or **ACC FUNCTION**, depending on the software release version of the OnGuard system. The component test screen shown in [Fig. 6.25](#) provides access to the following components (press the up or down arrows to scroll through the menu):

- brake pedal position

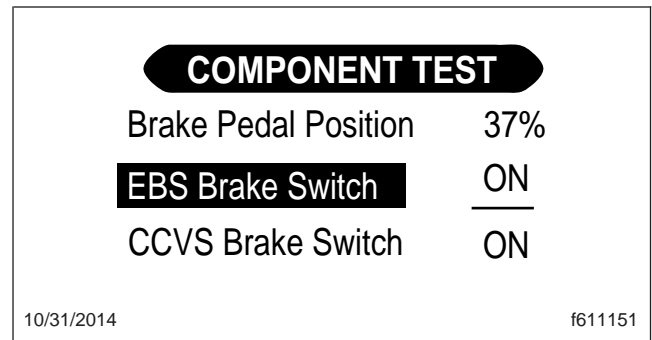

| COMPONENT TEST | |
|----------------------|-----------|
| Brake Pedal Position | 37% |
| EBS Brake Switch | <u>ON</u> |
| CCVS Brake Switch | ON |

10/31/2014 f611151

Fig. 6.25, Component Test Menu

- EBS brake switch
- CCVS brake switch
- clutch switch
- park brake switch
- accelerator pedal position
- driveline engaged
- cruise control enable
- cruise control set speed switch
- cruise control coast switch
- cruise control resume switch
- cruise control accelerate switch
- cruise control pause switch

Lane Departure Warning Controls

The Lane Guidance lane departure warning system monitors the vehicle's position within the roadway lane markings and sounds a warning in the cab when the vehicle is about to stray outside its lane, provided the turn signal is not on and the vehicle is traveling at least 37 mph (60 km/h). The system includes a digital camera mounted high near the center of the windshield inside the cab and speakers that emit a sound similar to a rumble strip. The sound is made on the side of the vehicle it's straying toward, prompting the driver to respond and steer away from the sound and back into the center of the correct lane.

Driver Assistance Features

WARNING

The lane departure warning system is intended only as an aid for a conscientious and alert driver. The system may not indicate lane departures under certain conditions. Read carefully the information in this manual to understand the circumstances under which this system may not provide adequate lane departure warnings. Do not rely solely on the system to safely operate the vehicle. The system does not warn of all possible hazards. For example, the system cannot prevent an accident if the driver is impaired or not driving safely.

The lane departure warning system is not a substitute for safe driving procedures.

Failure to drive safely and use the system properly could result in personal injury and/or death and severe property damage.

The lane departure warning system powers up each time the ignition is turned to ON. The system conducts a self test, and initiates test tones from the left speaker and then the right speaker. Once the vehicle is started and the system is ready, the LED in the switch illuminates.

Press the LANE ALERT switch to temporarily disable the lane departure warning system. See [Fig. 6.26](#). Some vehicles are equipped with a timer that automatically re-enables the warning system after 15 minutes. On all other vehicles, the warning system will remain disabled until the driver enables the system by pressing the LANE ALERT switch again, or the ignition is cycled off and then on.

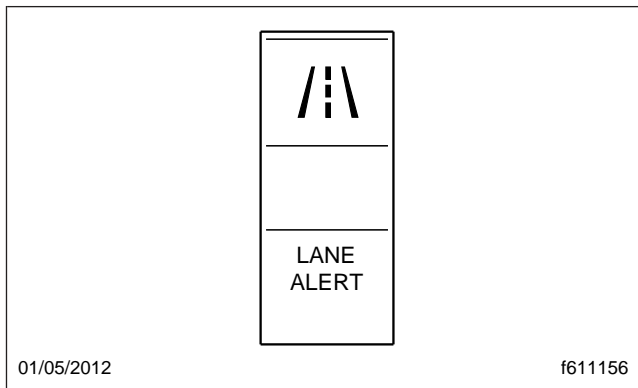

Fig. 6.26, Lane Departure Warning System Disable Switch

When the vehicle approaches the lane markings on either side, the system sense the activation of a turn signal. If a turn signal has not been activated, the system initiates the audible warning to alert the driver that the vehicle is departing its current lane of travel.

The LANE SRCHNG warning light illuminates to indicate the system is not fully functional. When the warning light is on, the system audible alert may not indicate a lane departure. Conditions that can cause the warning light to illuminate include:

- The system is unable to detect lane markings.
- Vehicle speed is less than 37 mph (60 km/h).
- A system problem is detected.

Roll Stability System

The roll stability system may include the roll stability advisor (RSA) only, or it may also include the roll stability control (RSC).

A decal ([Fig. 6.27](#)) on the auxiliary dash panel, and an amber-colored dash indicator light ([Fig. 6.28](#)), indicate that the vehicle is equipped with roll stability system components.

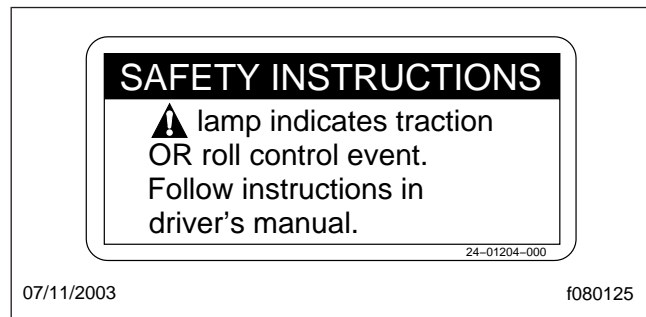

Fig. 6.27, Roll Stability Decal



Fig. 6.28, Roll Stability Indicator Lamp

Roll Stability Advisor

IMPORTANT: This is not an advance warning system. The roll stability advisor displays a message only after the driving maneuver is completed.

The roll stability system uses a lateral-acceleration sensor that monitors rollover risk. Shortly after a curve, lane change, or other driving maneuver that results in a rollover-risk detection, a dash warning light illuminates, an audible tone sounds, and a driver advisory message is displayed in the driver message center. The purpose is to advise the driver that the previous maneuver produced a rollover risk.

The roll stability advisor displays different text messages depending on the severity of the risk of each occurrence of risky driving. From the highest risk level to the lowest risk level, the system will sound an audible alert, and display a message, as shown in **Fig. 6.29**.

NOTE: The system will calculate and recommend a speed reduction value. It may be different than the values shown here.

Bring the vehicle to an authorized service facility if a system failure message is displayed.

Roll Stability Control



The Roll Stability Control system is intended only as an aid for a conscientious and alert driver. Carefully read the information in this manual to understand this system and its limitations. The Roll Stability Control system is not a substitute for safe driving procedures. Failure to drive safely, and use the system properly, could result in personal injury and/or death and property damage.

The roll stability control system automatically reduces engine power, applies the engine brake, and/or applies the tractor and trailer brakes when the acceleration sensor detects that the vehicle is at risk of rolling over. The control can intervene even before an advisory message is displayed.

The dash indicator light illuminates whenever the roll stability control system intervenes.

| MSG No. | Message | Message to Display | Display Time: Seconds | Buzzer Time: Seconds |
|---------|--------------|--------------------|-----------------------|----------------------|
| 1 | System Fault | | 4 | 1 |
| 2 | RSC | | 4 | None |
| 3 | RSA Level 3 | | 19.6 | 10 |
| 4 | RSA Level 2 | | 14 | 5 |
| 5 | RSA Level 1 | | 8.4 | 2 |
| 6 | HBED Level 3 | | 14 | 0.5 |
| 7 | HBED Level 2 | | 14 | 0.5 |
| 8 | HBED Level 1 | | 14 | 0.5 |

07/25/2008

f040769

Fig. 6.29, Roll Stability and Hard-Braking Warnings

Driver Assistance Features

Hard-Braking Advisor

The hard-braking advisor uses the information from the ABS wheel speed sensors to determine when braking is severe enough to produce lockup at one or more wheels on the tractor, and/or very rapid vehicle deceleration. Shortly after a hard-braking event occurs, an advisory message is displayed in the driver message center, indicating that the braking behavior was too aggressive for the current road surface conditions. This system is not a replacement for a driver's good judgment. Sometimes it is necessary to brake hard.

From the highest risk level to the lowest risk level, the system will sound an audible alert, and display a message, as shown in [Fig. 6.29](#).

Trip/Leg Totals

The driver message center records the number of messages received, and displays the number of messages as counts. Roll stability advisor (RSA) and hard-braking event data (HBED) counts can be viewed in the trip advisory screen, and the leg advisory screen.

Counts can be reset using the + key on the steering wheel. Clearing RSA and HBED leg counts will also reset the leg miles and leg hours. Clearing RSA and HBED trip counts will also reset trip miles, trip hours, leg miles, leg hours, and leg advisory counts. In addition, resetting leg miles will clear leg counts. Clearing trip miles will reset miles, hours, and counts in both the leg and trip screens.

The TRIP and LEG advisor screens count both the roll stability advisories (ROLL) and hard-braking events (BRK). For example, if during a TRIP, the driver message center recorded the events in [Table 6.1](#), the message center would display as shown in [Fig. 6.30](#).

| RSA/HBED Count | |
|------------------|----------------|
| Message Received | Message Counts |
| RSA Level 3 | 2 |
| RSA Level 2 | 3 |
| RSA Level 1 | 7 |
| HBED Level 3 | 5 |
| HBED Level 2 | 1 |
| HBED Level 1 | 8 |

Table 6.1, RSA/HBED Count

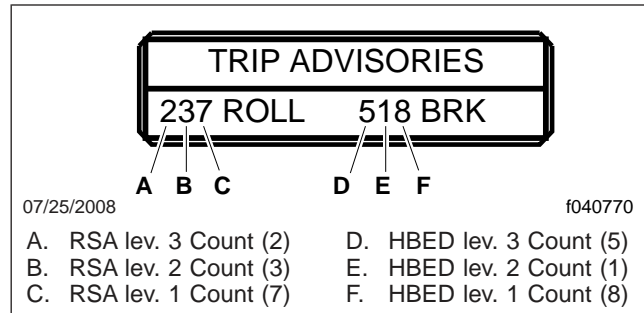

Fig. 6.30, Trip Advisor Message Screen

If the count reaches more than 9 occurrences an up-arrow symbol will appear, to indicate to the driver that the count has exceeded 9 counts. See [Fig. 6.31](#).

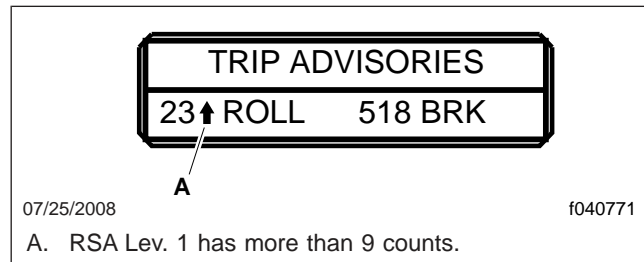

Fig. 6.31, Trip Advisor Message Screen (more than 9 counts)

Enhanced Stability Control



Enhance Stability Control (ESC) is intended only as an aid for a conscientious and alert driver. Carefully read the information in this manual to understand this system and its limitations. ESC is not a substitute for safe driving procedures. Failure to drive safely, and use the system properly, could result in personal injury and/or death and property damage.

ESC offers the full capability of RSC (shown above) with the added capability of complete directional stability (yaw control) in oversteer and understeer conditions to reduce the likelihood of drift-out or jackknife. The system determines where the driver is attempting to steer the vehicle and how much brake demand is required in order to more precisely control the vehicle in an emergency situation.

ESC works by constantly comparing the driver's intention with the vehicle's actual behavior. The system does this by monitoring systems such as wheel speed, steering angle, yaw rate, lateral acceleration, throttle position, and brake application. A central microcomputer analyzes the collected data and triggers a response to keep the vehicle on course when an unstable condition is detected.

When the system detects that the vehicle is at risk of oversteering or understeering, it applies individual tractor wheel end brakes and trailer brakes, activates the engine retarder (if equipped), and/or cuts engine power, depending on the severity. As a result, the driver has full control over the vehicle until the system detects a potential risk and intervenes accordingly. ESC operates automatically; the driver does not monitor or activate the system.

7

Seats and Restraints

| | |
|--|-----|
| Seats, General Information | 7.1 |
| Cascadia 2.0 High-Back Seat | 7.2 |
| Cascadia High-Back Seat | 7.3 |
| Sears Atlas Seat | 7.4 |
| Seat Belts and Tether Belts | 7.5 |
| Steering Wheel Air Bag | 7.8 |
| RollTek Rollover Protection System | 7.9 |

Seats and Restraints

Seats, General Information

Unless otherwise noted, all seat adjustments should be made while seated and before the engine is started.

Due to the high degree of adjustability of mid- and high-back air suspension seats, it is possible to combine the seat back recline adjustment and the seat slide adjustment so that the seat back contacts the back wall. Use care when adjusting the seat to prevent damage to the seat and the cab interior.

WARNING

Keep hands, tools, and other objects away from the scissor points under the seats. Failure to do so could cause personal injury.

The following is a description of adjustments that can be made to various Freightliner-installed seats. Not all seats have all of the adjustments listed below. See [Fig. 7.1](#).

- *Backrest Tilt* enables the backrest to pivot forward or backward.

- *Lumbar Support* changes the shape of the backrest to give more or less support to the occupant's lumbar (lower back) area. This adjustment is either mechanical or air controlled, depending on the seat model.
- *Fore/Aft Isolator* feature reduces the amount of road shock by isolating the occupant from the motion of the vehicle, and allowing the upper seat to move in a simple pendulum motion. A lockout feature is used whenever the isolator is not desired.
- *Height Adjustment* moves the entire seat up or down. The adjustment is either manually- or air-controlled, depending on the seat model.
- *Bottom Cushion Angle (fore-and-aft bottom cushion height)* enables the occupant to raise or lower the front or back of the bottom cushion. This adjustment is easier to perform when all weight is removed from the seat.
- *Fore/Aft Seat Slide (seat track adjustment)* moves the entire seat forward or backward on its track.

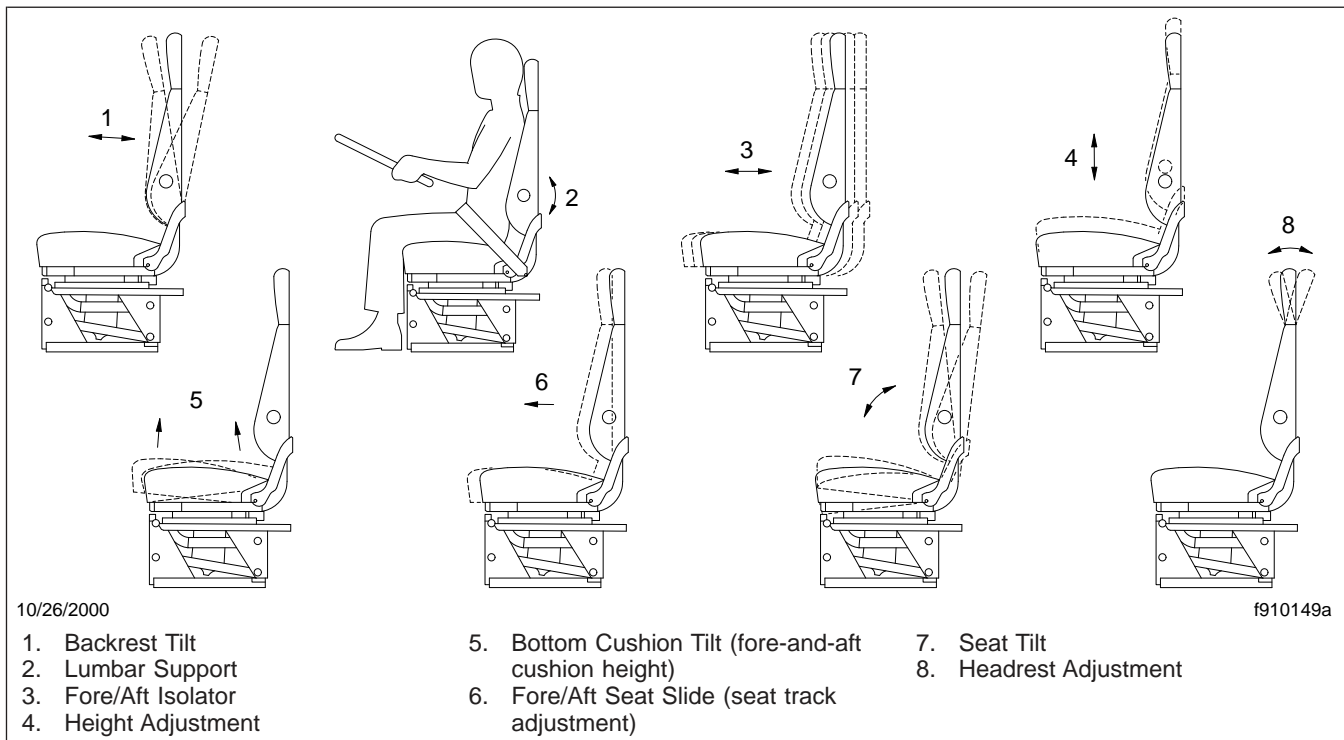

Fig. 7.1, General Seat Adjustments

- *Seat Tilt* allows the seat assembly (back and bottom cushions) to tilt forward or backward.
- *Headrest Adjustment* changes the angle of the upper part of the backrest to provide head and upper back support.

Cascadia 2.0 High-Back Seat

See [Fig. 7.2](#) for seat adjustment controls. Not all models of the Cascadia 2.0 Hi-Back seat have all the adjustments listed below.

Recline

Pull the recline handle to adjust the backrest tilt.

Seat Heating/Ventilation

Use the forward switch to turn the seat heater and ventilation ON or OFF. To turn on the heat, push the top of the switch. To turn on the ventilation, push the bottom of the switch. To turn off the heat or ventilation, move the switch to the middle position. To adjust the heat or ventilation, Use the rear button to adjust seat heating or ventilation. Three settings are available: low, medium, and high. See [Fig. 7.3](#).

NOTICE

Do not install seat covers on seats with heating and ventilation. Do not cover the seat with blankets, clothing, or pillows. Blocking the air flow through the cushions can overheat and damage the seat.

IMPORTANT: Turn off seat heating/ventilation when the seat is unoccupied.

Lumbar Support

Press the forward button to adjust lower lumbar support, the middle button to adjust upper lumbar support, and the rear button to adjust side support.

Height Adjustment

Pull or push the lever to adjust seat height.

Shock Absorber Adjustment

Move the lever down to increase damping on rough roads, or up to decrease damping on flat roads.

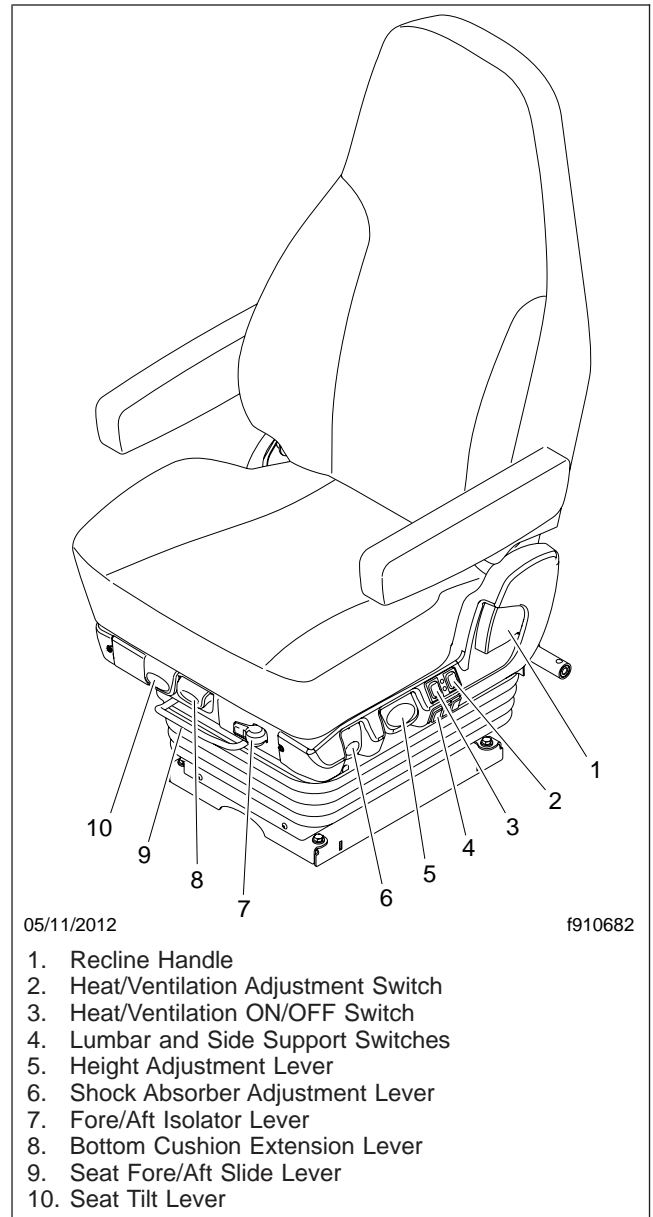

Fig. 7.2, Cascadia 2.0 Hi-Back Seat

Fore/Aft Isolator

Rotate the isolator knob to the left to lock the isolator, or to the right to allow movement.

Seats and Restraints

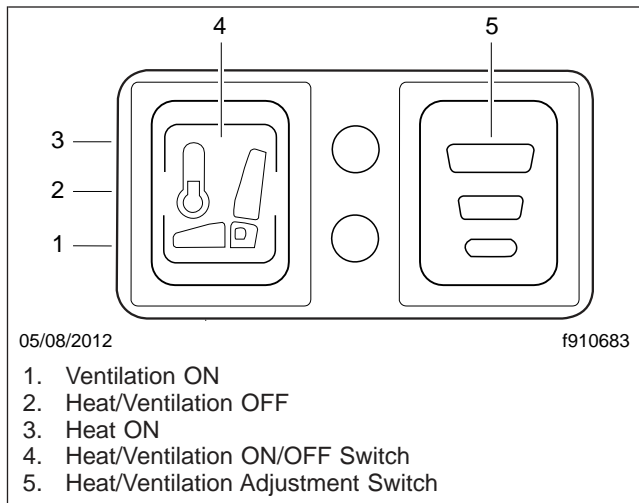

Fig. 7.3, Cascadia 2.0 Hi-Back Seat Heat/Ventilation Controls

Bottom Cushion Extension

Pull the lever to move the seat cushion forwards or backwards. The cushion moves 2-3/8 inches (60 mm) in 3/8-inch (10-mm) increments.

Seat Fore/Aft Slide

Lift the lever to slide the seat forward or backward. Release the lever to lock the seat in position.

Seat Tilt

Pull the lever and lean back to tilt the seat backwards. Three positions are available.

Armrest Angle

To adjust the armrest angle, tilt the armrest to the highest position, then down to the lowest position, then to the desired position.

Cascadia High-Back Seat

See [Fig. 7.4](#) for seat adjustment controls.

Backrest Tilt

To tilt the backrest, lean forward slightly to remove pressure from the cushion, then turn the knob forward or rearward to achieve the desired position.

Lumbar Support

To adjust the lumbar support, use the lumbar support switches on the side of the seat.

Height Adjustment

To raise or lower the height of the seat, use the height adjustment switch on the side of the seat.

Bottom Cushion Extension

To adjust the fore-and-aft position of the seat cushion, remove your weight from the seat, then lift up and pull forward on the cushion adjustment handle. To return the cushion to the aft position, lift up and push rearward.

Fore/Aft Seat Slide

To adjust the fore-and-aft position of the entire seat, move the fore-and-aft seat adjustment lever to the left and slide the seat forward or backward to the desired position. Move the lever back to its original position to lock the seat in place.

Fore/Aft Isolator

To engage the isolator, turn the isolator knob rearward to the unlocked position. Turn the isolator knob forward to the locked position when the isolator feature is not desired.

Shock Absorber

To adjust the amount of damping the shock absorber provides, move the lever up to increase damping; move the lever down to decrease damping.

Front Cushion Height

To adjust the height of the front of the cushion, remove your weight from the seat, then turn the adjustment knob toward the front of the seat (clockwise) to increase cushion height. To lower the cushion height, turn the adjustment knob toward the rear of the seat (counterclockwise).

Rear Cushion Height

To adjust the height of the rear of the seat cushion, remove your weight from the seat and turn the rear cushion adjustment knob to one of three positions.

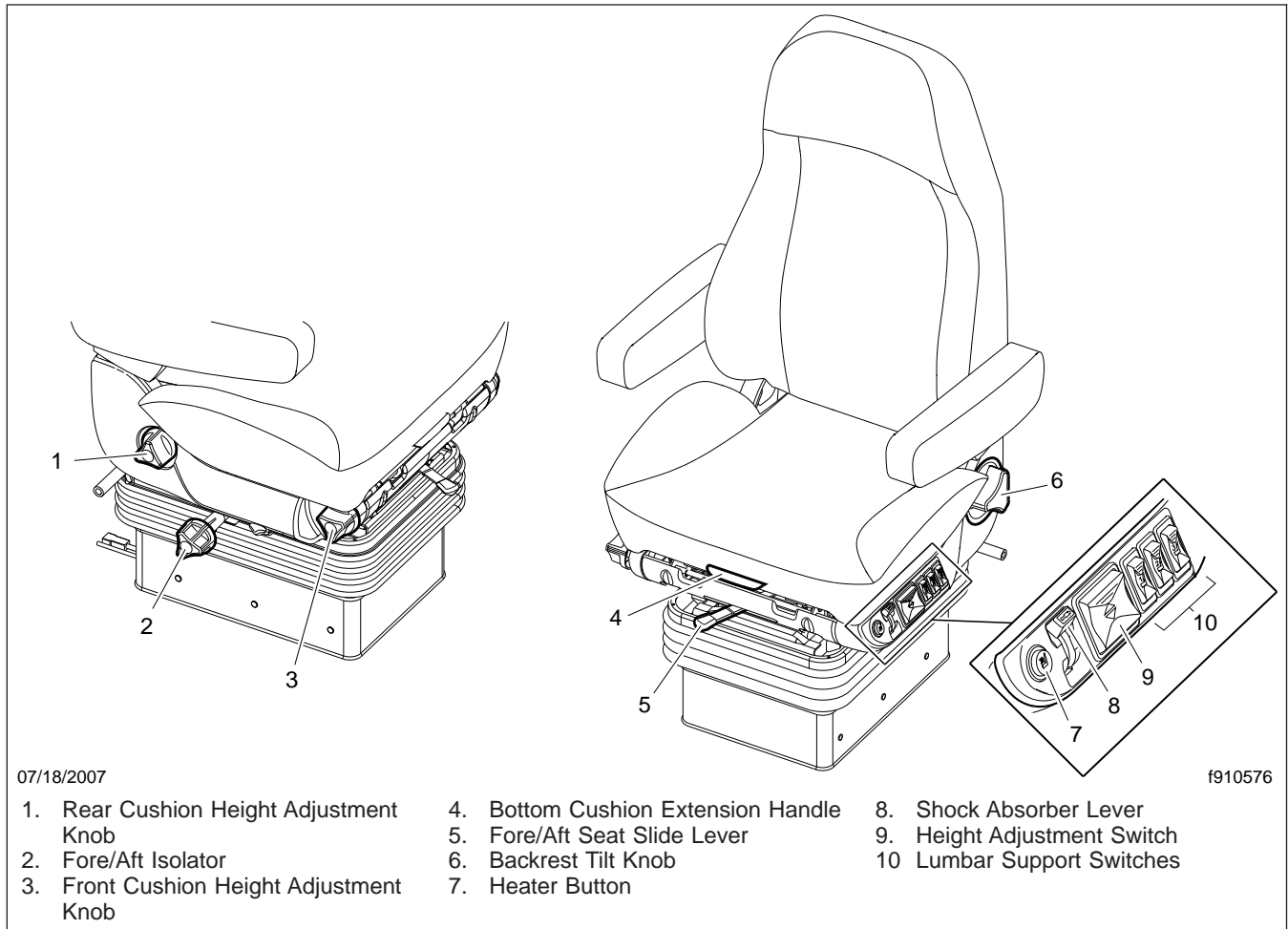

Fig. 7.4, Cascadia Hi Back Seat

Heater

To turn on the heat option, press the button. To turn off the heat option, press the button again. If the vehicle has Optimized Idle, seat heating will not operate with the key in accessory mode. Optimized Idle may also turn seat heating off to reduce stress on the batteries. Refer to [Chapter 11](#) for more information.

Sears Atlas Seat

See [Fig. 7.5](#) for seat adjustment controls.

Backrest Tilt

Pull upward on the recliner handle, move the backrest to the desired position and release the handle.

Lumbar Support

Rear rocker switch: Push forward to inflate the lower lumbar bag; push rearward to deflate the bag. Center rocker switch: Push forward to inflate the upper lumbar bag; push rearward to deflate the bag.

Fore/Aft Seat Slide

To adjust the fore-and-aft position of the entire seat, squeeze the fore/aft slide lock against the adjustment bail, and lift the bail up. See [Fig. 7.6](#). Slide the seat

Seats and Restraints

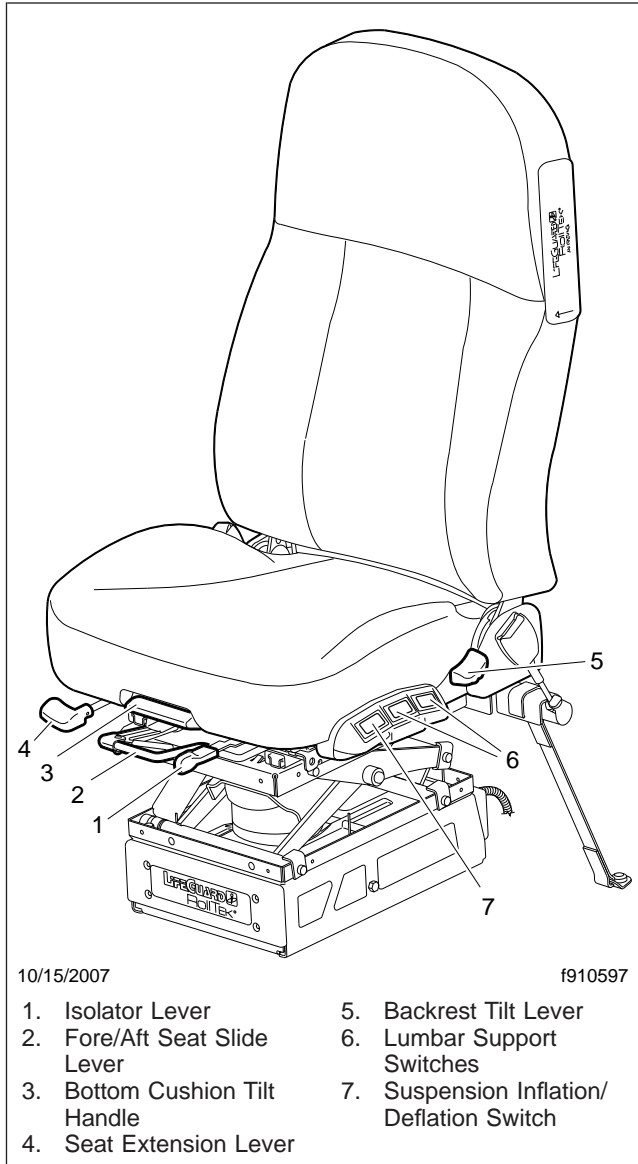

Fig. 7.5, Sears Atlas Seat

forward or backward to the desired position. Release the bail and fore/aft slide lock, to its original position, to lock the seat in place.

Bottom Cushion Tilt

Lift the handle upward and move the seat cushion to the desired position. Three positions are available.

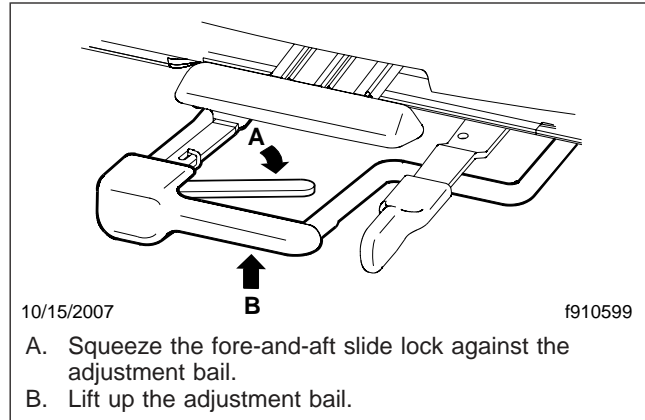

Fig. 7.6, Fore/Aft Slide Adjustment, Sears Atlas Seat

Armrest Angle

Rotate the control knob, located on the underside of the armrest, to set the desired angle of the armrest.

Isolator

Position the handle to the left to allow isolation movement. Position the handle to the right to lock-out isolation movement.

Suspension Inflation/Deflation

Push forward on the gray rocker switch to inflate and raise the suspension; push rearward to deflate and lower the suspension.

Seat Extension

Rotate the handle upward to disengage, then move the seat cushion to the desired position and release the lever. Three positions are available.

Seat Belts and Tether Belts

Seat belt assemblies are designed to secure persons in the vehicle to help reduce the chance of injury, or the amount of injury, resulting from accidents or sudden stops. For this reason, Daimler Trucks North America LLC (DTNA) urges that the driver and *all* passengers, regardless of age or physical condition, use seat belts when riding in the vehicle.

WARNING

Always use the vehicle's seat belt system when operating the vehicle. Failure to do so can result in severe personal injury or death.

Seat belt assemblies in DTNA vehicles meet Federal Motor Vehicle Safety Standard 209, "Type 1" and "Type 2" requirements.

When transporting a child, always use a child restraint system or the vehicle seat belts as appropriate. To determine whether a child restraint system is required, review and comply with applicable state and local laws. Any child restraint used must comply with Federal Motor Vehicle Safety Standard 213, "Child Restraint Systems." When providing a child restraint system, always carefully read and follow all instructions pertaining to installation and usage for the child. Make certain the child remains in the restraint system at all times when the vehicle is in motion.

In addition to seat belt assemblies, tether belts are installed on suspension-type seats. Tether belts help secure the seat to the floor and are intended to restrain the seat and seat belt in case of an accident or sudden stop.

IMPORTANT: Seat belts have a finite life which may be much shorter than the life of the vehicle. Regular inspections and replacement as needed are the only assurance of adequate seat belt security over the life of the vehicle.

Seat Belt Inspection

WARNING

Inspect and maintain seat belts. When any part of a seat belt system needs replacement, the entire seat belt must be replaced, both retractor and buckle side. Any time a vehicle is involved in an accident, and the seat belt system was in use, the entire vehicle seat belt system must be replaced before operating the vehicle. Do not attempt to modify the seat belt system; doing so could change the effectiveness of the system. Failure to replace worn or damaged seat belts, or making any modifications to the system, may result in personal injury or death.

Inspect the seat belts and tether belts (if so equipped).

1. Check the web for fraying, cuts, extreme dirt and dust, or for severe fading from exposure to sunlight, especially near the buckle latch plate and in the D-loop guide area.
2. Check operation of the buckle, latch, Komfort Latch or Sliding Komfort Latch (if equipped), web retractor, and upper seat belt mount on the door pillar. Check all visible components for wear or damage.
3. Check the seat belt and tether belt connection points and tighten any that are loose.

Seat Belt Operation

WARNING

Wear three-point seat belts only as described below. Three-point seat belts are designed to be worn by one person at a time. In case of an accident or sudden stop, personal injury or death could result from misuse.

Fasten the seat belts before driving. Fastening a three-point seat belt while driving creates a hazard.

When engaged and used properly, the Komfort Latch ([Fig. 7.7](#)) and the Sliding Komfort Latch ([Fig. 7.8](#)) introduce a small amount of slack into the seat belt, resulting in a more comfortable ride.

1. Slowly pull the link end of the seat belt out of the retractor and pull it across your lap (from outboard to inboard) far enough to engage the buckle. If the retractor locks too soon, allow the belt to retract slightly, then slowly pull it out again. See [Fig. 7.9](#).
2. Fasten the seat belt by pushing the latch into the buckle. Listen for an audible click.
3. Tug on the seat belt to make sure it is securely fastened. If the buckle unlatches, repeat this step. If the problem continues, replace the seat belt.
4. Snug the seat belt to your waist.

Seats and Restraints

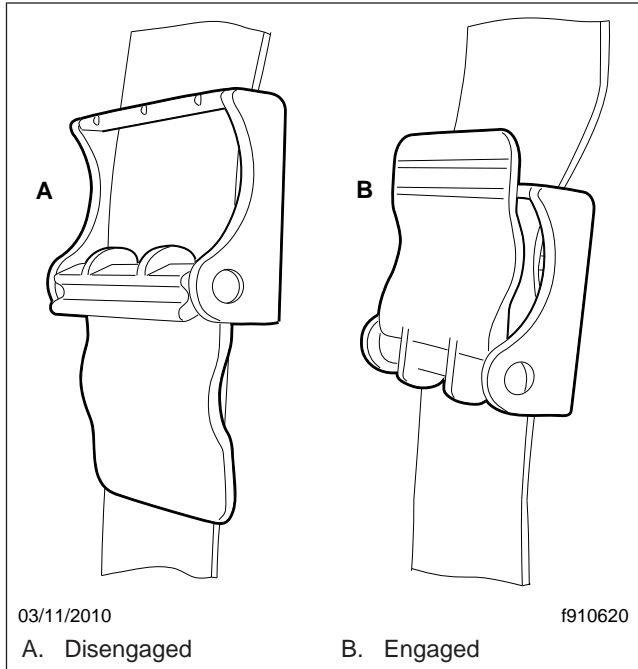

Fig. 7.7, Komfort Latch

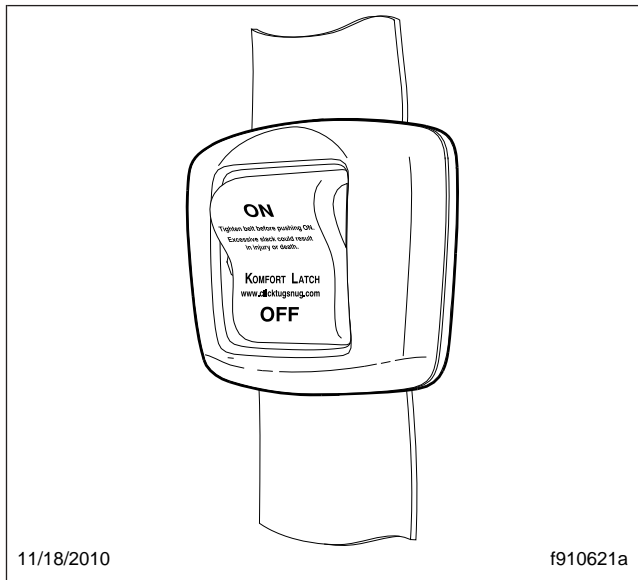

Fig. 7.8, Sliding Komfort Latch

WARNING

Before activating the Komfort Latch or the Sliding Komfort Latch, make sure the amount of

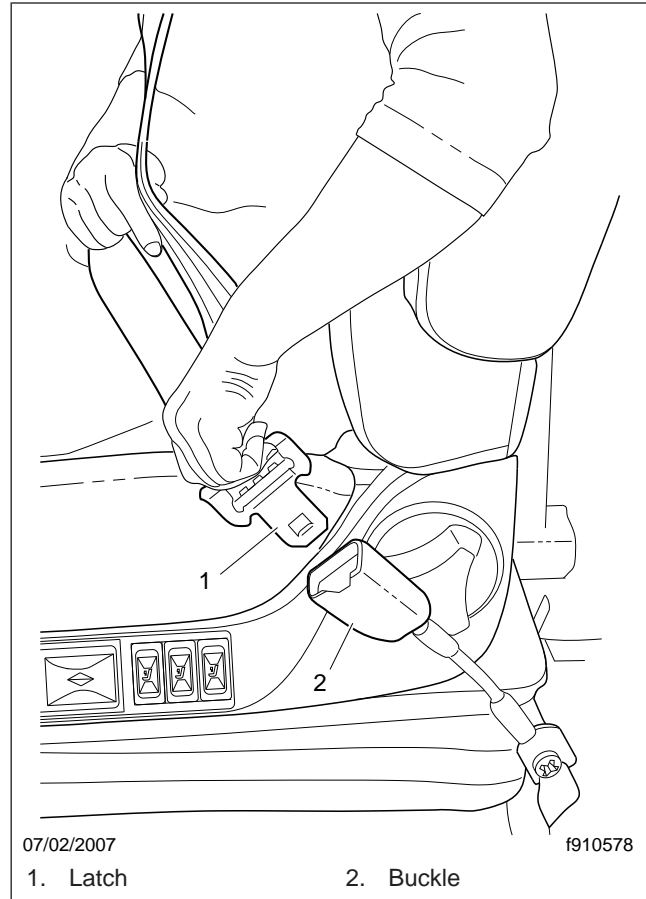

Fig. 7.9, Three-Point Seat Belt Operation

slack in the shoulder strap is set as described below. Excess slack in the shoulder strap reduces the effectiveness of the seat belt, and increases the risk of injury or death in an accident.

5. Position the shoulder strap diagonally across your chest with the adjustable D-loop bracket (if equipped). The shoulder strap must be centered on your shoulder and chest, away from your face and neck. See Fig. 7.10. If desired, engage the Komfort Latch or Sliding Komfort Latch as follows.

If equipped with a Sliding Komfort Latch, make sure that the shoulder strap is snug against your chest. Without loosening the shoulder strap, push the Sliding Komfort Latch switch to the "ON" position. See Fig. 7.8. To activate the latch lean forward until you hear a click. This will allow

for approximately 1 inch (2.5 cm) of slack between your chest and the shoulder harness. Once engaged, the latch will allow you to lean forward about 5 inches (13 cm) without having to reset the latch. Leaning forward more than 5 inches (13 cm) will disengage the Sliding Komfort Latch, requiring it to be reset.

If equipped with a Komfort Latch, pull on the shoulder strap to lessen the pressure of the strap on your shoulder and chest. Allow no more than 1 inch (2.5 cm) of slack between your chest and the shoulder harness. More slack can significantly reduce the seat belt effectiveness in an accident or a sudden stop. While holding the belt slack, press the Komfort Latch lever up, clamping the seat belt webbing (Fig. 7.11 and Fig. 7.12).

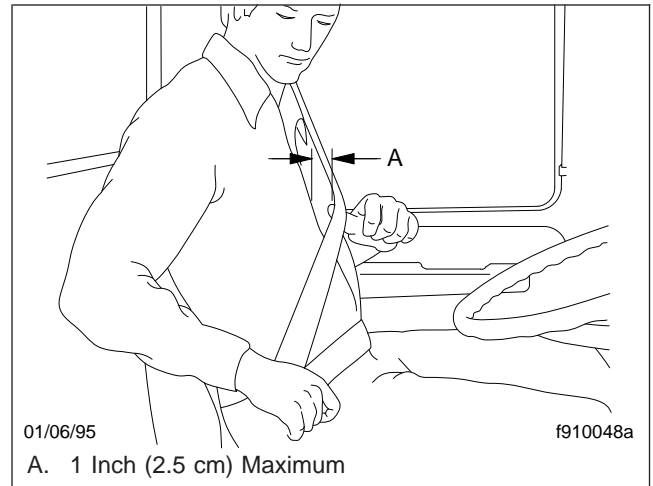

Fig. 7.11, Adjusting Shoulder Harness Clearance, Komfort Latch

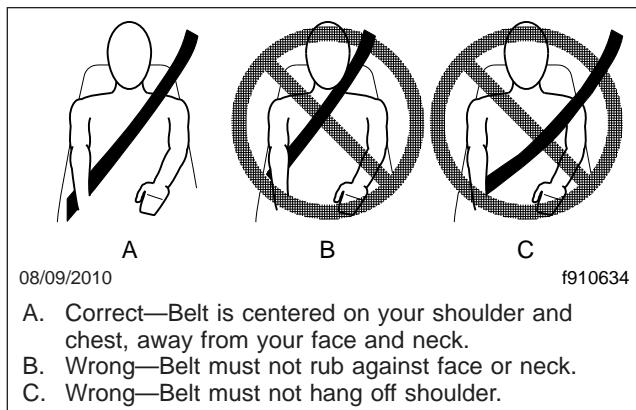

Fig. 7.10, Proper Shoulder Strap Fit

- Unbuckle the seat belt and release the Komfort Latch or the Sliding Komfort Latch as follows.

If equipped with a Sliding Komfort Latch, unbuckle the seat belt, then tug on the shoulder belt to release the Sliding Komfort Latch, or press the Sliding Komfort latch to the "OFF" position, then unbuckle the seat belt.

If equipped with a Komfort Latch, unbuckle the seat belt, then release the Komfort Latch by giving the shoulder belt a quick tug. If you lean forward against the shoulder belt, the Komfort Latch will automatically release, and will need to be reset.

NOTE: Neither the Komfort Latch nor the Sliding Komfort Latch need to be manually released in an emergency situation. Each will release by

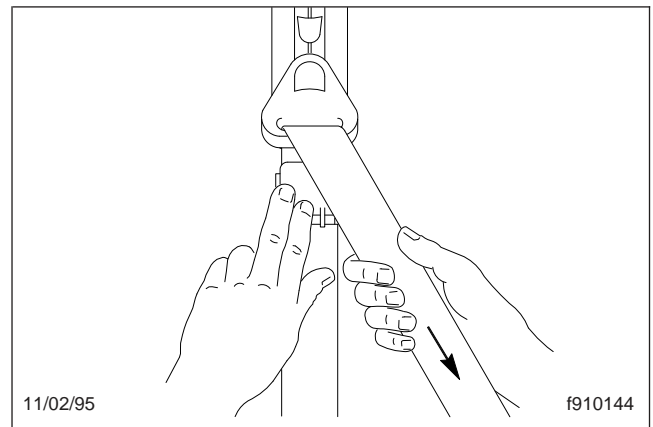

Fig. 7.12, Locking the Komfort Latch

itself under rough road or other abnormal conditions. Make sure the seat belt is completely retracted when it is not in use.

Steering Wheel Air Bag

Operation

NOTE: Only vehicles with the letters "SRS" molded into the steering wheel center pad are equipped with a steering wheel air bag.

The air bag, when used with seat belts, provides additional protection to the driver in severe frontal collisions. Steering wheel air bags are designed to inflate only in severe frontal collisions. The driver and the

Seats and Restraints

passenger should always wear seat belts. The steering wheel air bag will activate during a collision even if the seat belts are not fastened, but the system is designed to provide protection to the occupant only when the seat belts are fastened.

WARNING

Keep all heavy objects in the cab secured. Do not place objects on the steering wheel or between you and the steering wheel. Any such objects may cause harm during an accident. Keep your hands on the sides and lower portion of the steering wheel. Failure to follow these instructions may result in death or personal injury.

For maximum protection in a collision, always be in a normal seated position with your back against the seat back and your head upright. Fasten your seat belt and ensure that it is properly positioned on your body as described under the "Seat Belt Operation" heading. Since the air bag inflates with considerable speed and force, a proper seat position will help keep you a safe distance from the inflating air bag.

Inspection and Service

WARNING

Do not attempt to service or modify the air bag system. Unintentional or improper air bag deployment could cause severe bodily injury or death. Contact an authorized Freightliner service facility for all service and maintenance.

The air bag system contains components that use combustible chemicals. Do not cut, drill, braze, solder, weld, strike, or probe the air bag components. Keep all liquids and chemicals away from air bag components.

The surface of the deployed air bag may contain small amounts of sodium hydroxide (which is a by-product of the gas generant combustion) and metallic sodium. Sodium hydroxide may be irritating to the skin and eyes. Immediately wash your hands and exposed skin areas with a mild soap and water. Flush your eyes immediately if exposed to sodium hydroxide.

The operational readiness of the air bag system is indicated by the supplemental restraint system (SRS) indicator on the dash. The SRS indicator illuminates

for several seconds when the ignition is turned on, and then it goes off. The indicator will remain on if there is a problem with the air bag system. The vehicle should be serviced if the SRS indicator does not illuminate when the ignition is turned on, or if the SRS indicator remains on.

The air bag module may contain perchlorate material; for information, see www.dtsc.ca.gov/hazardouswaste/perchlorate. Special handling may apply; follow appropriate rules and regulations when disposing of materials.

For all service and maintenance, contact an authorized Freightliner service facility.

RollTek Rollover Protection System

Identification

Only seats with the RollTek module under the seat and the molded side-roll air bag cover on the upper side of the seat back are equipped with the RollTek rollover protection system; see [Fig. 7.13](#). RollTek may be installed in one of the following configurations:

- driver seat only or driver and passenger seats
- driver seat only, with an optional steering wheel frontal air bag
- driver and passenger seats, with an optional steering wheel frontal air bag

Operation

The RollTek system, when used with seat belts, provides additional protection to the driver and passenger (if equipped with a passenger-side system) in rollover accidents. The RollTek system provides a significant increase in seat stability during a rollover. Vehicles equipped with RollTek rollover protection have a sensor mounted in the seat base that activates the side-roll air bag and seat pull-down device during a rollover.

When the RollTek module senses a rollover, the module triggers gas cylinders mounted in the base of the seat. The gas cylinders activate the power cinches that then tighten the lap and shoulder belts against the occupant of the seat and lower the seat suspension, moving the occupant down and away from the steering wheel and ceiling. The side-roll air

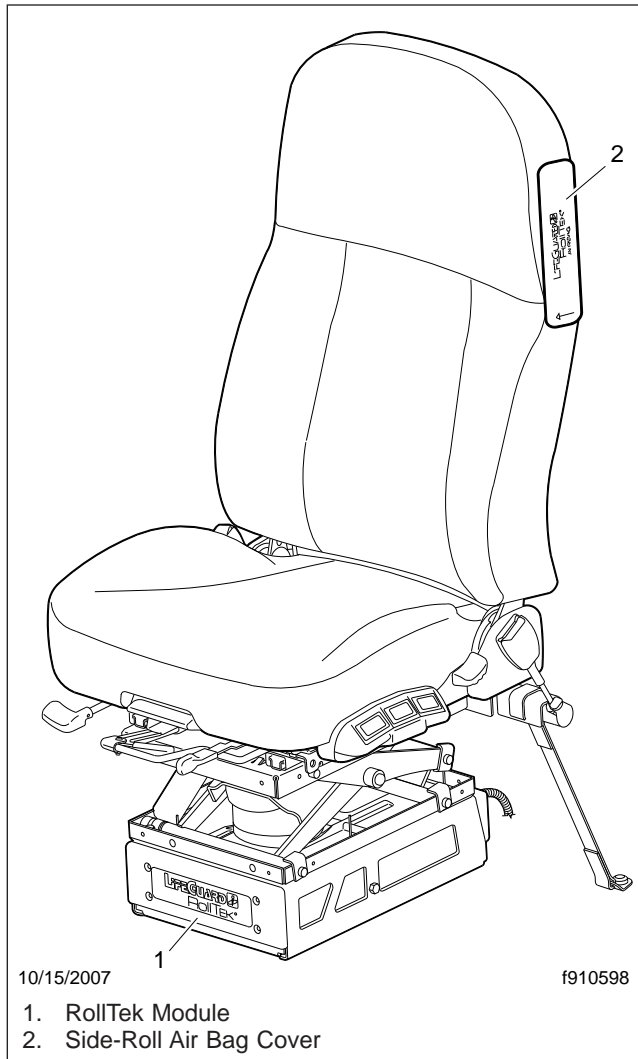

Fig. 7.13, RollTek Protection System Components

bag deploys from the outboard side of the seat as the seat is pulled down to its lowest position. See [Fig. 7.14](#).

! WARNING

Always use the seat belts when operating the vehicle. Failure to do so can result in severe personal injury or death. Do not place infants and children in seats equipped with the RollTek system. The RollTek system is designed for adults only. Doing so could result in severe bodily injury or death. Keep all heavy objects in the cab secured. Do not place objects on the seat back

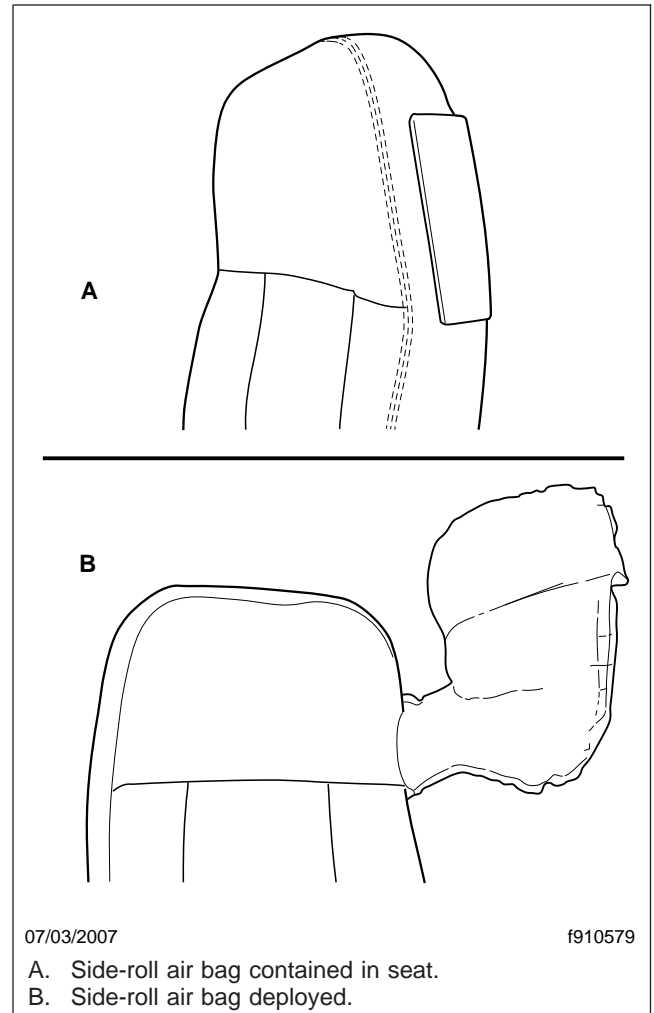

Fig. 7.14, Side-Roll Air Bag

or block the side-roll air bag. Objects that block the side-roll air bag may prevent proper inflation and could result in serious injury or death.

The RollTek system will activate during a rollover even if the seat belts are not fastened, but the RollTek system is only designed to provide protection to the occupant when the seat belts are fastened.

For vehicles with the RollTek system(s) only, device(s) deploy as follows:

- Rollover Crash—occupant seat belt pretensioning, seat pretensioning, and side-roll air bag at the proper time
- Frontal Crash—no devices deployed

Seats and Restraints

For vehicles with the RollTek system(s) and frontal steering wheel air bag, device(s) deploy as follows:

- Rollover Crash—occupant seat belt pretensioning, seat pretensioning, and side-roll air bag at the proper time
- Frontal Crash—steering wheel air bag, occupant seat belt pretensioning, seat pretensioning, and the side-roll air bag at the proper time

Inspection and Service



Keep hands and tools away from the scissor points under the seats.

The RollTek system contains components that use combustible chemicals. Do not cut, drill, braze, solder, weld, strike, or probe any part of the RollTek system. Keep all liquids and chemicals away from the RollTek components.

Do not attempt to service or modify the RollTek system. Unintentional or improper deployment of the RollTek system could cause severe bodily injury or death. Contact an authorized Freightliner service facility for all service and maintenance.

IMPORTANT: The RollTek system must be replaced after being activated. Damaged seat belts and tethers, or seat belts and tethers that were worn in an accident, must be replaced, and their anchoring points must be checked.

The operational readiness of the RollTek system is indicated by the supplemental restraint system (SRS) indicator on the dash. The SRS indicator illuminates for several seconds when the ignition is turned on, and then it goes off. The indicator will remain on if there is a problem with the air bag or RollTek system. The vehicle must be serviced if the SRS indicator does not illuminate when the ignition is turned on, or if the SRS indicator remains on.

The air bag module may contain perchlorate material; for information, see www.dtsc.ca.gov/hazardouswaste/perchlorate. Special handling may apply; follow appropriate rules and regulations when disposing of materials.

For all service and maintenance, contact an authorized Freightliner service facility.

8

Climate Control

| | |
|-------------------------------------|-----|
| Cab Climate Control Panel | 8.1 |
| Sleeper Climate Control Panel | 8.2 |
| ParkSmart™ HVAC System | 8.3 |
| Accessory Heaters | 8.5 |

Climate Control

Cab Climate Control Panel

The standard cab climate control panel has a fan switch with a recirculation button, temperature control switch with an A/C button, and a mode control switch. See [Fig. 8.1](#). Sleeper cabs are also equipped with a bunk override button.

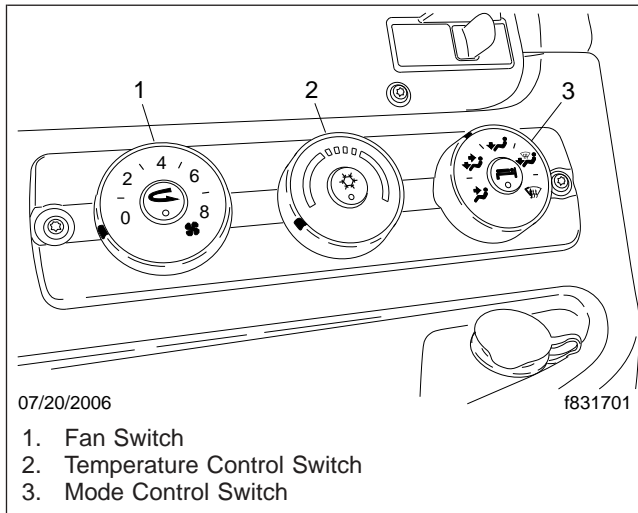

Fig. 8.1, Cab Climate Control Panel

Fan Switch

The fan switch activates the fan, which forces fresh air or recirculated air through the air outlets. The fan switch has eight fan speed settings and an OFF position. See [Fig. 8.2](#).

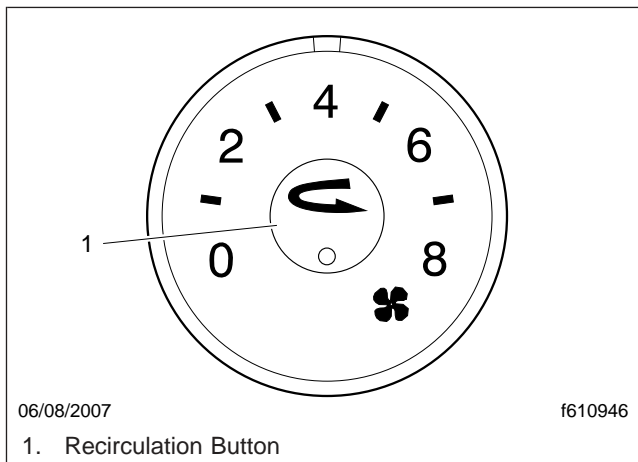

Fig. 8.2, Fan Switch

To operate the fan switch, turn the fan switch clockwise to increase airflow; turn the fan switch counterclockwise to decrease airflow.

There is a two-second delay between the time the engine is started and the blower is operational. It can take an additional four seconds for the blower to reach high speed. The blower motor performs a self-test immediately after the engine is started, which causes the delay. If the vehicle has Optimized Idle, the fan will not operate with the key in accessory mode. Optimized Idle may also turn the fan off to reduce stress on the batteries. Refer to [Chapter 11](#) for more information.

Recirculation

Recirculation mode limits the amount of outside air entering the cab. Press the recirculation button to prevent dusty or smoky air from entering the cab. See [Fig. 8.2](#). Recirculation mode can also decrease the time required to cool or heat the cab interior during extreme outside temperature conditions. When the recirculation mode is turned on, the amber indicator on the recirculation button will illuminate.

The recirculation button will not work when the mode control switch is in either defog or defrost modes.

NOTE: To prevent the buildup of odors or oxygen depletion inside the cab, the system switches from full recirculation mode to partial recirculation mode after 20 minutes. In extremely dusty or smoky conditions, the partial recirculation mode can be overridden by pressing the recirculation button twice to obtain full recirculation mode. This resets the 20-minute timer.

Temperature Control Switch

The temperature control switch is used to select the desired temperature in the cab. Turn the switch counterclockwise for cool air, or clockwise for hot air. See [Fig. 8.3](#).

Air Conditioning Button

The air conditioner (A/C) cools and dehumidifies the air inside the cab. Press the A/C button, located in the center of the temperature control switch, to turn the air conditioner on and off. See [Fig. 8.3](#).

A/C will be automatically disabled when:

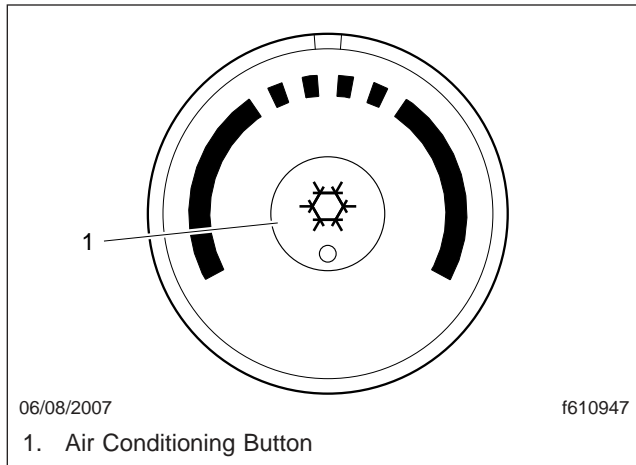

Fig. 8.3, Temperature Control Switch

- outside air temperature is low enough to make the A/C ineffective;
- engine is running at extremely low rpm;
- conditions exist that result in the climate control system going into protection mode.

Mode Control Switch

The mode control switch allows the driver to control the flow of air through the face outlets, the floor outlets, the defrost (windshield) outlets, or a combination of these outlets. See [Fig. 8.4](#).

- *Face Mode*: Directs all airflow through the face or instrument panel outlets.
- *Bi-Level Mode*: Directs the airflow equally to the face outlets and the floor outlets.
- *Floor Mode*: Directs all airflow through the floor outlets.
- *Floor/Defrost Mode*: Directs the airflow equally to the floor outlets and the defrost outlets.
- *Defrost Mode*: Directs all airflow through the defrost outlets.

Bunk Override Button

The bunk override button, equipped on sleeper cabs only, allows the driver to control the sleeper heat and A/C settings from the cab. See [Fig. 8.4](#).

Press the bunk override button to turn the sleeper heat or A/C on. An amber indicator will illuminate when bunk override mode is activated.

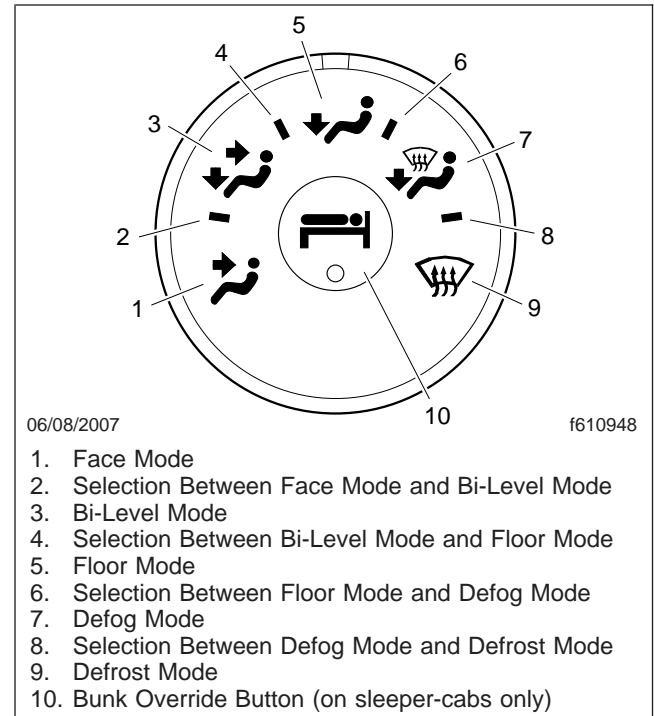

Fig. 8.4, Mode Control Switch With Bunk Override Button

Press the bunk override button again to turn bunk override mode off. Adjusting the sleeper climate controls at any time will also cause the bunk override mode to cancel.

Sleeper Climate Control Panel

The standard sleeper climate control panel has a fan switch and a temperature control switch with an A/C button.

If the bunk override button has been activated, the override mode can be canceled by changing the sleeper fan speed or temperature setting. The climate control system will then operate from the sleeper controls.

Fan Switch

The fan switch activates the fan, which forces air through the air outlets. The fan switch has eight fan speeds and an OFF position. See [Fig. 8.5](#).

To operate the fan switch, turn the switch clockwise to increase airflow; turn the fan switch counterclockwise to decrease airflow. If the vehicle has Optimized

Climate Control

Idle, the fan will not operate with the key in accessory mode. Optimized Idle may also turn the fan off to reduce stress on the batteries. Refer to [Chapter 11](#) for more information.

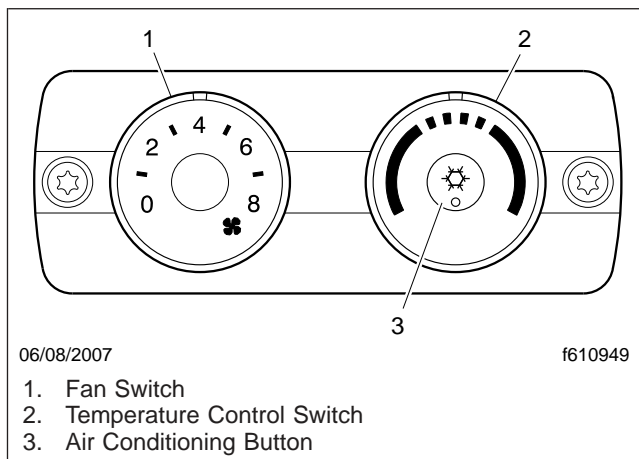

Fig. 8.5, Sleeper Climate Control Panel

NOTE: When the cab air conditioner (A/C) is on, the sleeper fan will operate at low speed even if the sleeper fan switch is in the off position. This is necessary to protect the evaporator in the sleeper heater and air conditioner system from freezing. In lower fan speed settings, a slight increase in airflow levels may appear at times, as the control acts to regulate the evaporator temperature.

Temperature Control Switch

The temperature control switch is used to select the desired temperature in the sleeper. Turn the switch counterclockwise for cool air, or clockwise for hot air.

Air Conditioning Button

The A/C cools and dehumidifies the air inside the sleeper. Press the air conditioning button, located in the center of the temperature control switch, to turn the A/C on and off.

ParkSmart™ HVAC System

There are two variations of the ParkSmart vehicle configuration. The standard configuration is the most common, and includes all vehicles without Detroit Diesel Optimized Idle (O/I). The second variation in-

cludes vehicles equipped with Detroit Diesel Optimized Idle (O/I). Both configurations are operated in the same way, the differences are in how the batteries and charging system are configured. Refer to "Standard Vehicle Configuration" or "Vehicles with Detroit Diesel Optimized Idle" below for more information on your vehicle.

Standard Vehicle Configuration

The ParkSmart™ climate control panel replaces the standard sleeper control panel in ParkSmart-equipped sleeper cabs. The ParkSmart HVAC system is designed to maintain a comfortable temperature inside the sleeper, and can operate in combination with the cab climate control system when the vehicle is running, or independently when the vehicle is parked. It uses a set of four dedicated batteries mounted aft of the starting batteries, either between the frame rails behind the cab or outside the frame rail.

The ParkSmart climate controls operate similarly to the standard sleeper climate controls. The temperature settings range from 60°F (15°C) to 85°F (29°C), with 74°F (23°C) at the very center of the range. The fan switch activates the fan. The fan switch has eight fan speeds. Zero (0) is the OFF position. See [Fig. 8.6](#). To operate the fan switch, turn the switch clockwise to increase airflow; turn the fan switch counterclockwise to decrease airflow.

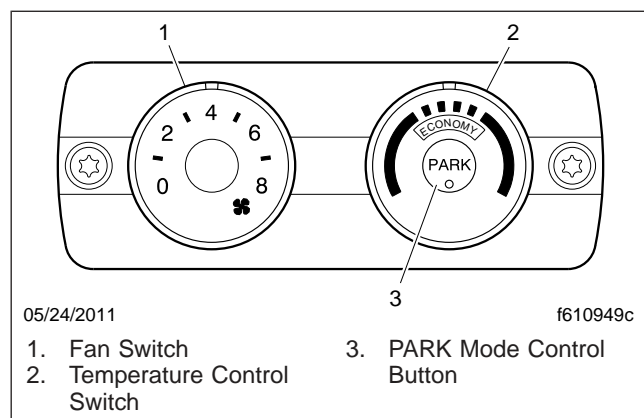

Fig. 8.6, ParkSmart Climate Control Panel

The ParkSmart HVAC system operates both when the engine is running and when the engine is off. When the engine is running, the air conditioning (A/C) is powered by the vehicle electrical system, while the auxiliary heater core is supplied with engine

coolant. While the engine is running, the ParkSmart batteries are also being recharged by the vehicle electrical system.

When the engine is off with the key in the ACC or ON positions, A/C mode is powered by the ParkSmart batteries. The cab fan will also circulate air in the cab using power from the main vehicle batteries. The available power for other vehicle-supplied accessories (house loads) will be affected when running in this mode. If there is no Low Voltage Disconnect (LVD) control on the main electrical system, the ability to start the vehicle could also be compromised if this mode is activated for an extended time period.

When the engine is off with the ignition switch in the OFF position, the ParkSmart system runs the battery-operated A/C or diesel-operated coolant heater, depending on the temperature requested, and power is drawn from the batteries. The main batteries and the ParkSmart batteries will both be used until the system voltage drops to 12.5 volts, then the system will switch to the ParkSmart batteries only. The ParkSmart system will run until the dedicated batteries reach 11.3 volts.

Before operating the ParkSmart system, bring the sleeper interior temperature to the desired temperature with the engine running and the bunk curtain open. The ParkSmart system is designed to maintain an established comfortable bunk temperature, in parked mode, for up to 12 hours with the bunk curtain closed. See [Table 8.1](#) for recommended settings

for comfort while the vehicle is parked. [Table 8.2](#) shows the temperature knob setting for desired temperatures.

To use the ParkSmart control panel, select a fan speed (other than off) and push the **PARK** button. Adjust the temperature control knob to the desired temperature. Refer to [Table 8.1](#) or [Table 8.2](#), depending what mode is being used.

Start the fuel-operated heater once per month and allow it to run for 15 minutes. Periodically running the heater will keep fresh fuel in the lines and ensure the heater is ready to perform when needed.

IMPORTANT: Wait three minutes after shutting down the ParkSmart system before turning the cab load disconnect switch (CLDS) to OFF.

NOTE: The Espar Hydronic 5 water heater can use biodiesel blends up to 10% (B-10). Consult the engine manufacturer's manual to confirm the lowest allowable blend (engine or heater) is not being exceeded.

IMPORTANT: The condition and charge of the auxiliary batteries will directly affect run time of the ParkSmart system. If the vehicle run-time between discharges is less than eight hours, or if additional loads are added to the auxiliary batteries, the ParkSmart run-time will be less than expected.

| Parked HVAC Comfort Guide | | | | |
|---------------------------|--|---------------------------------|----------------------|----------------------------------|
| Rest Hours Desired | Weather | | Setting Guide | |
| | Outdoor Temperature Less Than or Equal to: °F (°C) | Sunshine Less Than or Equal to: | Maximum Blower Speed | Minimum Temperature Knob Setting |
| 4 | 105 (40) | Light Sun | 8 | Full Cold |
| 6 | 95 (35) | Full Sun | 8 | Mid |
| | 90 (32) | Light Sun | 8 | Full Cold |
| | 100 (38) | Night Time | 8 | Full Cold |
| | 110 (43) | Full Sun | 6 | 3 O'clock |
| 8 | 75 (24) | Night Time | 6-8 | Full Cold |
| | 95 (35) | Light Sun | 6 | 10 O'clock |
| 10 | 85 (30) | Light Sun | 6 | 10 O'clock |
| | 100 (38) | Light Sun | 6 | Mid |
| | 95 (35) | Night Time | 6 | 10 O'clock |
| | 105 (40) | Night Time | 6 | Mid |

Climate Control

| Parked HVAC Comfort Guide | | | | |
|---------------------------|--|---------------------------------|----------------------|----------------------------------|
| Rest Hours Desired | Weather | | Setting Guide | |
| | Outdoor Temperature Less Than or Equal to: °F (°C) | Sunshine Less Than or Equal to: | Maximum Blower Speed | Minimum Temperature Knob Setting |
| 12 | 90 (32) | Night Time | 6 | 10 O'clock |
| | 100 (38) | Night Time | 6 | Mid |

Table 8.1, Parked HVAC Comfort Guide

| Temperature Control Knob Position to Requested Output Temperature | |
|---|--|
| Temperature Control Knob Position (Clicks) | Requested Sleeper Temperature: °F (°C) |
| 1 | 60 (16) |
| 2 | 60 (16) |
| 3 | 62 (17) |
| 4 | 64 (18) |
| 5 | 66 (19) |
| 6 | 68 (20) |
| 7 | 70 (21) |
| 8 | 71 (22) |
| 9 | 72 (22) |
| 10 | 73 (23) |
| 11 | 74 (23) |
| 12 | 75 (24) |
| 13 | 76 (24) |
| 14 | 77 (25) |
| 15 | 78 (25) |
| 16 | 79 (26) |
| 17 | 80 (27) |
| 18 | 82 (38) |
| 19 | 84 (29) |
| 20 | 85 (29) |
| 21 | Full Hot |

Table 8.2, Temperature Control Knob Position to Requested Output Temperature

Vehicles with Detroit Diesel Optimized Idle

If a Cascadia vehicle is equipped with Detroit Diesel optimized idle (O/I), it will affect the way the ParkSmart operates. When the driver initiates the O/I, the ParkSmart will operate in O/I mode as follows.

- The ParkSmart runs unless the ParkSmart fan speed control knob is turned to the "OFF" position. See Fig. 8.6. The fan speed control knob must be set at "1" or higher.
- The engine will periodically start and run for at least two hours to maintain battery voltage then shut off. The ParkSmart will continue to operate during this time.
- If the O/I shuts down due to a fault in the O/I system, the ParkSmart will continue to operate until it is shut off by the driver or one of the automated failsafes.
- The ParkSmart ON/OFF button and LED indicator on the parked HVAC control module do not function when the vehicle is in O/I mode. When the vehicle is not in O/I mode, the ParkSmart ON/OFF button and LED indicator operate normally.

All other functions are the same as the standard system.

Accessory Heaters

Optional accessory heaters are available from the factory in several configurations. Familiarize yourself with the equipment on your specific vehicle, and follow the manufacturer's operating and maintenance instructions.

WARNING

Do not operate fuel-operated heaters in an area where flammable vapors, including gasoline or diesel fumes, are present, such as at filling stations and tank farms. Turn off a fuel-operated heater and allow it shut down completely before entering an area where flammable gases or liquids are present. Heaters continue to operate for up to three minutes after being turned off.

Failure to observe these precautions could cause an explosion or fire, resulting in serious property damage, and personal injury or death.

NOTICE

Always ensure that air inlet and outlet grilles are not restricted. Restriction of any air inlet or outlet ports could result in damage to the auxiliary heater.

IMPORTANT: To maintain reliable performance, run the accessory heater for at least 15 minutes every month to prevent fuel from degrading.

Accessory heaters function when the ignition switch is in the off position and the cab load disconnect switch is on, if equipped.

IMPORTANT: Wait three minutes after shutting down an accessory heater before turning the cab load disconnect switch (CLDS) to OFF.

NOTE: The low voltage disconnect (LVD) control prevents a heater from draining the batteries below starting voltage.

Espar Heater

Refer to the Espar website, www.espar.com, for additional information.

Espar Mini-Controller

To turn the heat on, press the heat button. See [Fig. 8.7](#). The red indicator will illuminate when heat mode is activated. Adjust the desired temperature with the control knob; rotate the temperature control knob clockwise for warmer air, or counterclockwise for cooler air. To turn the heat off, press the off button.

To turn the fan on, press the fan button. The blue indicator will illuminate when ventilation mode is activated. To turn the fan off, press the off button.

Espar Digi-Controller

Vehicles built after December 8, 2011 with the Digi-Controller and D2 air heaters are equipped with an internal LVD in the Digi-Controller that prevents the heater from draining battery voltage below 12.0 volts.

To turn heat mode on, press the heat button and the heater will begin its start-up cycle. See [Fig. 8.8](#). ON

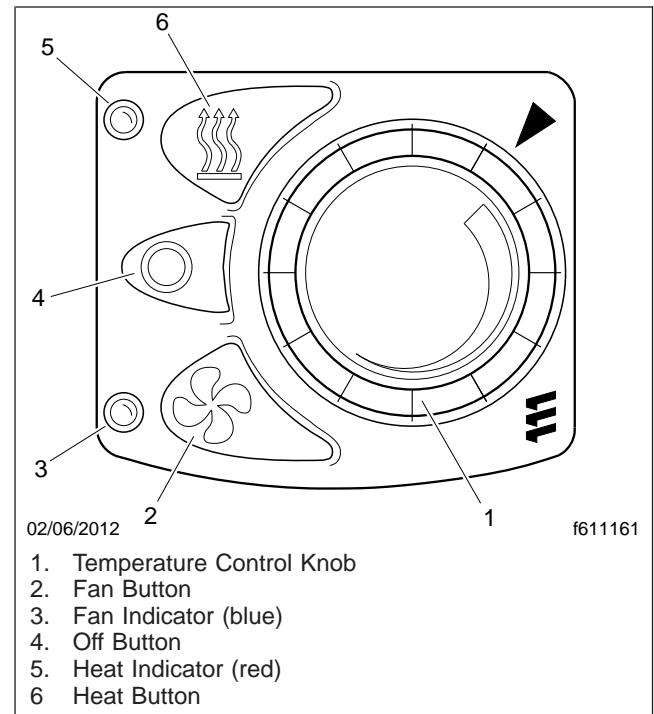

Fig. 8.7, Espar Mini-Controller

will display briefly followed by the ambient temperature, and the green indicator will illuminate. Ambient display temperature range is 41°F to 90°F.

To adjust the desired temperature, press the up or down arrow buttons. The desired temperature will display briefly, followed by the ambient temperature. The desired temperature will remain in the modulator memory when the heater is not in operation. Temperature adjustment range is from 41°F to 90°F.

To turn heat mode off, press the heat button again. The heater will initiate a 3-minute cooling cycle.

To turn the fan on, press and hold the fan button until the blue indicator illuminates and the display shows active rotating digits. To turn the fan off, press the fan button again.

NOTE: The Digi-Controller also has a programmable run timer that will automatically shut the heater off after the set time limit. The default time limit setting is 10 hours.

Climate Control

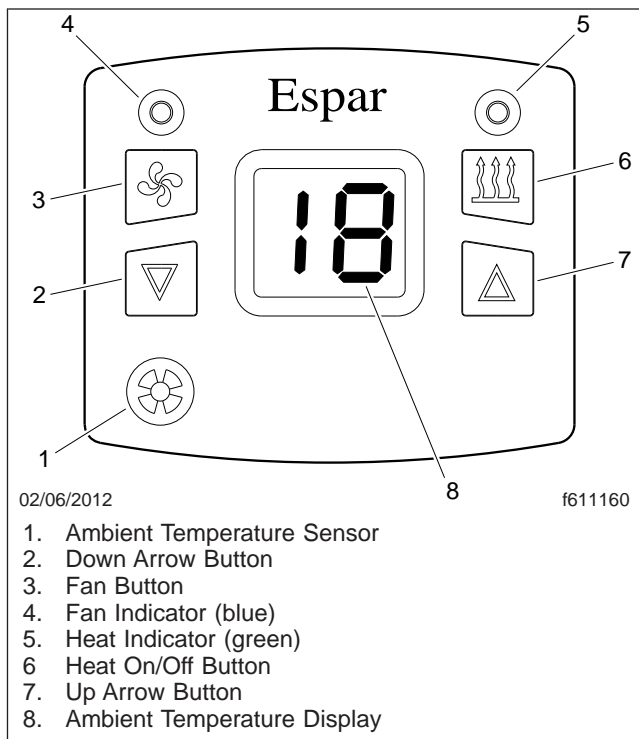

Fig. 8.8, Espar Digi-Controller

To set the desired temperature, rotate the heater control knob clockwise for warmer air, or counterclockwise for cooler air.

To turn the heater off, rotate the heater control counterclockwise until it clicks and the indicator light is extinguished. The heater will initiate a two-minute cooling cycle.

Refer to the Webasto website, techwebasto.com, for additional information.

Webasto Heater

To turn the heater on, rotate the heater control knob clockwise until the indicator light illuminates. See [Fig. 8.9](#). The Webasto heater requires one to two minutes to warm up before warm air is delivered.

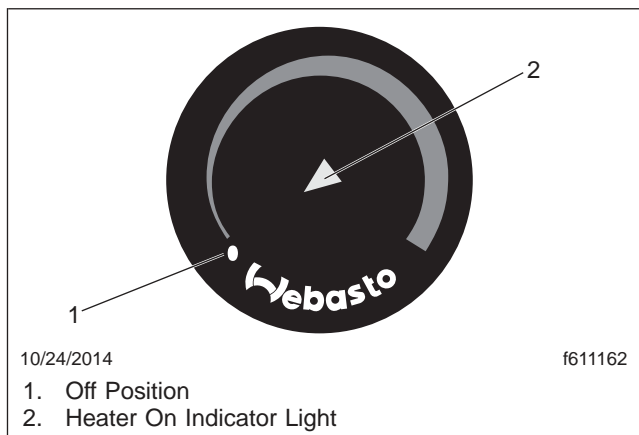

Fig. 8.9, Webasto Heater Control Knob

9

Cab Features

| | |
|-------------------------|-----|
| Windows | 9.1 |
| Mirrors | 9.1 |
| Cab Amenities | 9.1 |
| Sleeper Amenities | 9.2 |

Cab Features

Windows

Power windows are standard on Cascadia™ vehicles. The driver's door has two switches mounted in the top of the door, that control the driver and passenger windows separately. See [Fig. 9.1](#). The passenger door has a switch mounted in the top of the door that controls the passenger-side power window.

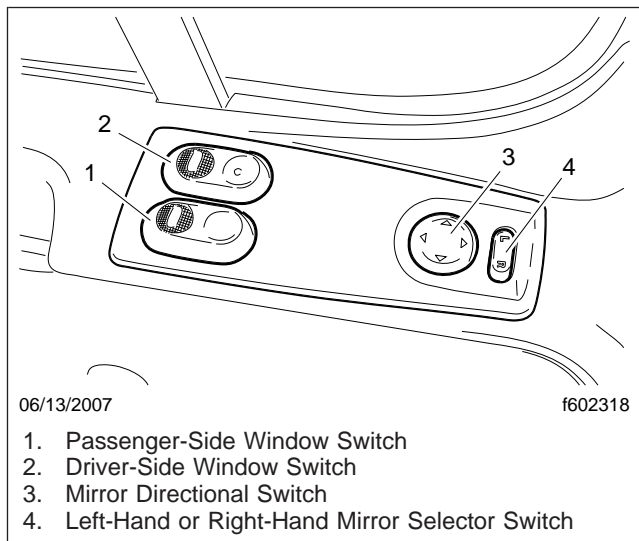

Fig. 9.1, Door Switches (driver-side shown)

WARNING

There is no anti-pinch protection when the window is almost closed. Be sure to clear all objects from the window before closing.

The window switches have three positions: lower window, neutral, and raise window. Press forward on the switch to lower the window. Hold the switch down in the forward position for approximately one second to activate the express function; the window will continue to roll down after the switch is released. Press the switch in the rearward position (bump) to raise the window.

Mirrors

The standard outside mirrors are mounted on the door frame. The power mirrors are controlled with a left-hand or right-hand mirror selector switch, and a directional switch. Select the left (driver) mirror, or the right (passenger) mirror using the selector switch.

The mirror can then be adjusted by pressing the directional switch arrow for the direction the mirror should be adjusted.

The outside door mirrors can be heated to keep them clear of fog, frost, and ice. To heat the mirrors, press the upper part of the mirror heat switch on the dash. See [Fig. 9.2](#). When the mirror heat switch is on, an amber indicator light illuminates inside the switch. If the vehicle has Optimized Idle, mirror heating will not operate with the key in accessory mode, or if the Optimized Idle feature turns mirror heating off to reduce stress on the batteries. Refer to [Chapter 11](#) for more information.

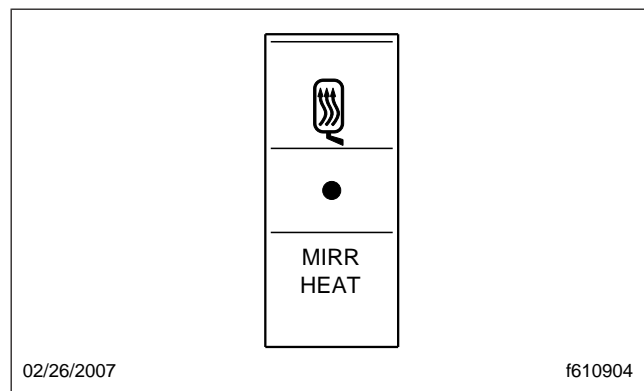

Fig. 9.2, Mirror Heat Switch

Cab Amenities

Cascadia vehicles are available with many optional features. The following are some of those options.

Cup Holders

Two cup holders and a storage tray are molded into the center dash. See [Fig. 9.3](#).

Lighting

See [Chapter 5](#) for detailed information regarding lighting controls.

Power Outlets

Power outlets that supply 12V power for accessories are located on either side of the cup holders. An optional ashtray/coin holder may be located in the center dash. See [Fig. 9.3](#).

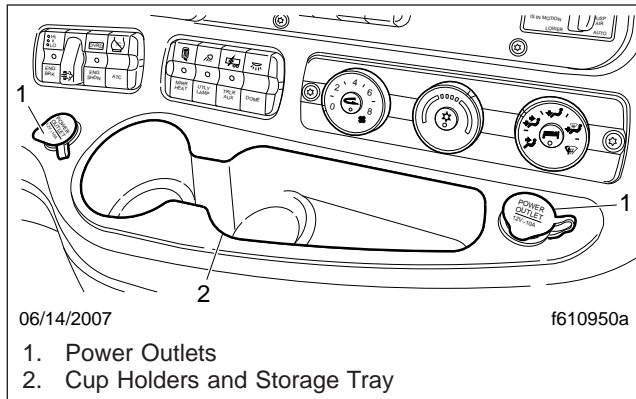

Fig. 9.3, Center Dash

Radio and CB

The radio and CB are typically installed in the overhead console. An optional hot mount may be installed on the dash for fleet CB radios.

Storage

Storage compartments/grab handles are molded into the lower portion of the driver and passenger doors.

The glove box is located in front of the passenger seat. To lock the latch, insert the key in the lock, and turn it 1/2-turn clockwise. Remove the key. To unlock the latch, insert the key in the lock, and turn it 1/2-turn counterclockwise. The glove box door is hinged at the bottom. To open the unlocked door, push the button in with your thumb and pull gently on the tang-style latch. The door will swing downwards, then stop in the open position. To close the door, swing it upwards, and put gentle pressure on the latch. The door will be secured, but not locked.

Storage pockets are located in the overhead console, above the driver and passenger seats. A glove box is located in the center of the overhead console. See [Fig. 9.4](#).

Sleeper Amenities

Cascadia sleepers are available with many optional features. The following are some of those options.

NOTE: See [Chapter 8](#) for detailed information regarding sleeper climate controls.

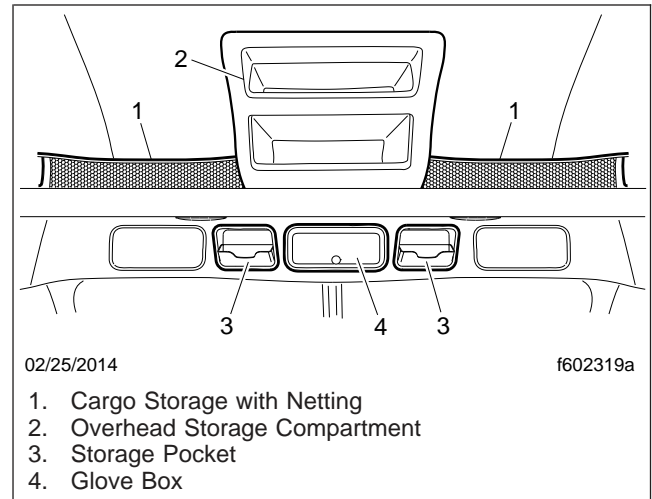

Fig. 9.4, Overhead Storage

Baggage Compartment Doors

The baggage compartment doors are intended as a convenient means to stow or remove items under the bunk. The baggage compartment doors can be opened using the pull cable located near the aft edge of the cab door opening on the sidewall behind the seat. Pull the cable handle labeled **BAGGAGE** forward to open the door.

IMPORTANT: The baggage compartment doors are two-stage latching. When closing the doors, ensure that they are completely latched to prevent wind noise and water intrusion.

Lighting

See [Chapter 5](#) for detailed information regarding lighting controls.

Power Outlets

Power outlets are located underneath the lower bunk.

Sleeper Access Door

The sleeper access door is not intended for entry or exit. The door is intended only as a convenient means to stow or remove personal belongings in the sleeper area. The sleeper access door can be opened using two different methods. The primary method is the pull cable located near the lower rear edge of the cab door opening on the sidewall behind

Cab Features

the seat. Pull the cable handle labeled ACCESS forward to open the sleeper door. The secondary method is the black knob located at the upper rear edge of the sleeper door opening. Pull the knob down to open the sleeper door.

IMPORTANT: The sleeper access doors are two-stage latching. When closing the doors, ensure that they are completely latched to prevent wind noise and water intrusion.

Sliding Side Window

The lower section of the sliding side window moves vertically and may be locked in multiple positions to suit. Two spring-loaded tabs are located at the top of the sliding section. To adjust the window, pull both tabs toward the center of the glass and move the sliding section to the desired height. Release the tabs to lock the sliding section.

10

Engine Starting, Operation, and Shutdown

| | |
|------------------------|------|
| Engine Starting | 10.1 |
| Engine Operation | 10.2 |
| Engine Shutdown | 10.4 |

Engine Starting, Operation, and Shutdown

Engine Starting

This engine chapter is to serve as a guide for best practices only. Each engine model may have operating characteristics that are unique to that particular engine, and will be documented in the engine manufacturer's literature. Always refer to specific instructions and recommendations from the engine manufacturer.

NOTE: Before starting the engine, read **Chapter 4, Instruments**, and **Chapter 5, Driver Controls**. Read the engine manufacturer's operating instructions before starting the engine.

WARNING

Never pour fuel or other flammable liquid into the air inlet opening in the air intake in an attempt to start the vehicle. This could result in a flash fire causing serious personal injury or property damage.

IMPORTANT: Cascadia vehicles are equipped with starter interlocks to enhance reliability and safety. Anti-grinding, starter pinion, and thermal protection logic limit the amount of time and conditions for starter engagement. Cranking may be limited from 5 to 15 seconds, with a 30-second cool-down period, as determined by the protection logic. If the engine is turning, the starter will not engage. Depending on the transmission option, the starter will not engage if the clutch is not fully depressed, or if the transmission is not in neutral.

IMPORTANT: The starter **can not** be used for priming the fuel system. If the fuel/water separator filter is replaced, and the fuel system needs to be primed, see the engine manufacturer's operating instructions.

1. Before engine start-up, complete the pre- and post-trip inspections and maintenance procedures in **Chapter 21**.
2. Set the parking brake.
3. Place the transmission in neutral. On vehicles with manual transmissions, fully depress the clutch pedal.

NOTE: Depending on local jurisdictional emissions regulations, vehicles and/or engines that are domiciled outside of the U.S. and Canada may not be equipped with the WAIT TO START or START BLOCKED lamp.

4. Turn the ignition switch to the ON position and allow the gauge sweep to complete. See **Fig. 10.1**. The audible alert will sound for approximately four seconds.

During cold conditions, the WAIT TO START lamp may illuminate. Wait until the lamp goes out before turning the ignition key to START.

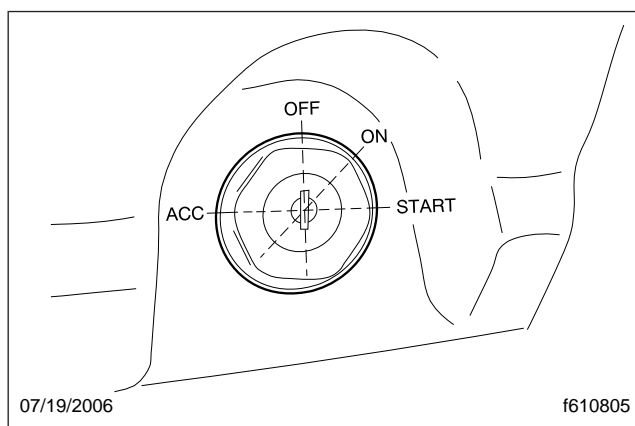

Fig. 10.1, Ignition Switch

NOTE: The length of time the WAIT TO START lamp remains illuminated depends on the ambient temperature. The lower the ambient temperature, the longer the lamp will be illuminated.

NOTE: If the ignition switch is turned to START before the gauge sweep has completed or if the starter has overheated, the START BLOCKED lamp may illuminate. Turn the ignition switch back to ON, wait for the lamp to go out, then turn the ignition switch to START again.

5. Once the gauge sweep has completed, turn the ignition key to the START position. Release the key the moment the engine starts.

NOTICE

Do not rev the engine if the oil pressure gauge indicates no oil pressure. Shut down the engine

Engine Starting, Operation, and Shutdown

if oil pressure does not build within approximately ten seconds. Check to determine the cause of the problem. Operating the engine with no oil pressure will damage the engine.

6. It is not necessary to idle the engine before engaging or starting the operation, but load should be applied gradually during the warm-up period until the oil temperature reaches 140°F (60°C).
7. Apply load gradually during the warm-up period.

NOTICE

If the oil pressure gauge indicates no oil pressure, shut down the engine within approximately ten seconds to avoid engine damage.

8. Check the oil pressure gauge for any drop in lubricating oil pressure or mechanical malfunction in the lubricating oil system. Minimum oil pressure at idle is 7 psi (50 kPa).

Cold-Weather Starting

See the engine manufacturer's operation manual for starting aids that are approved for specific engines.

Starting After Extended Shutdown

Before engine start-up, complete the engine pretrip inspections in [Chapter 21](#).

NOTICE

Failure to eliminate water-diluted lubricating oil may lead to serious engine damage at startup.

An engine in storage for an extended period of time (over winter, for example) may accumulate water in the oil pan through normal condensation of moisture on the internal surfaces of the engine. Oil diluted by water cannot provide adequate bearing protection at start-up. For this reason, change the engine oil and filters after extended storage.

Engine Operation

Safety and Environmental Considerations

 **WARNING**

Do not operate the engine in an area where flammable vapors such as gasoline or diesel fumes are present. Shut off the engine when in an area where flammable liquids or gases are being handled. Failure to observe these precautions could result in serious injury or death.

All engines on Freightliner vehicles comply with the requirements of the Federal (U.S.) Clean Air Act. Once an engine is placed in service, the responsibility for meeting both state and local regulations is with the owner/operator.

IMPORTANT: Depending upon local jurisdictional emissions guidelines, vehicles that are domiciled outside of the U.S. and Canada may not have engines and/or emissions aftertreatment systems that are compliant with EPA07, EPA10, or GHG14 regulations.

NOTICE

It is extremely important that the following guidelines be followed for engines that comply with EPA07 or newer regulations, or damage may occur to the aftertreatment device, and the warranty may be compromised.

- **Use ultralow-sulfur diesel with 15 ppm sulfur content or less.**
- **Do not use fuel blended with used engine lube oil or kerosene.**
- **Use only engine lube oil with a sulfated ash level less than 1.0 wt%; currently referred to as CJ-4 oil.**

Adequate maintenance of the engine and the diesel particulate filter (DPF) are the responsibility of the owner/operator, and are essential to keep the emission levels low. Good operating practices, regular maintenance, and correct adjustments are factors that will help keep emissions within the regulations.

The driver should be familiar with the vehicle warning system in order to bring the vehicle to a safe stop if

Engine Starting, Operation, and Shutdown

the engine malfunctions. If the driver doesn't understand how the warning system works, an engine shutdown could occur, causing a safety hazard. See [Chapter 11](#) for more information.

Engine Break-In

Each engine must pass a full-load operating test on a dynamometer before shipment, thereby eliminating the need for a break-in. Before running the engine for the first time, follow the instructions in the manufacturer's engine operation manual.

Normal Operation



Do not operate the engine in an area where flammable vapors such as gasoline or diesel fumes are present. Shut off the engine when in an area where flammable liquids or gases are being handled. Failure to observe these precautions could result in serious injury or death.

Every engine has an operating range in which it performs most efficiently. The operating range extends from maximum torque rpm at the low end, to engine rated speed at the high end. Most engines deliver best fuel economy when operated in the low- and mid-speed segments of the efficiency range and produce maximum horsepower at rated speed, which is also the recommended maximum speed of the engine. For further engine-specific information, refer to the engine manufacturer's operation manual.

Prolonged idling of engines is not recommended, and is illegal in some states. Idling produces sulfuric acid that is absorbed by the lubricating oil, and eats into bearings, rings, valve stems, and engine surfaces. If you must idle the engine for cab heating or cooling, use the high idle function of the cruise control switches. An idle speed of 900 rpm should be enough to provide cab heat in ambient temperatures that are above freezing.

If the engine is programmed with an idle shutdown timer, 90 seconds before the preset shutdown time, the CHECK engine light will begin to flash at a rapid rate. If the position of the clutch pedal or service brake changes during this final 90 seconds the idle shutdown timer will be disabled until reset.

Cold-Weather Operation

Satisfactory performance of a diesel engine operating in low ambient temperatures requires modification of the engine, surrounding equipment, operating practices, and maintenance procedures. The lower the temperature, the greater the amount of modification required. For service products approved for use in cold weather for your engine, see the engine manufacturer's engine operation manual.

If satisfactory engine temperature is not maintained, maintenance costs will increase due to greater engine wear. If the engine coolant gets too cold, raw fuel will wash the lubricating oil off the cylinder walls and dilute the crankcase oil, causing all moving parts of the engine to suffer from poor lubrication.

If the engine is in good mechanical condition and the precautions necessary for cold-weather operation are taken, ordinary cold weather will not cause difficulty in starting or loss of efficiency.

The following points are important to observe when operating in cold weather.

- Check for cracks in the battery cases, for corrosion of the terminals, and for tightness of the cable clamps at the terminals.
- Charge the batteries to full capacity. Replace damaged batteries.
- If equipped, turn off the load disconnect switch after the engine is shut down to prevent battery discharge.
- Have the alternator output checked at an authorized Freightliner service provider.
- Check the condition and tension of the drive belts.
- Refer to the engine manufacturer's operation manual for recommended heaters, low-viscosity lubricating oils, winter-grade fuels, and approved coolants.
- Periodically check the coolant mixing ratio (concentration of antifreeze in the coolant). Add more if necessary.
- At outside temperatures below -4°F (-20°C), a coolant preheater is recommended.

Engine Starting, Operation, and Shutdown

NOTICE

For Detroit engines (EPA07 and newer), use of a winterfront is not recommended, as it can cause false fault codes with the engine and aftertreatment system, and possible emission component failures.

If using a winterfront, leave at least 25% of the grille opening exposed in sectioned stripes that run perpendicular to the charge-air-cooler tube-flow direction. This assures even cooling across each tube, and reduces header-to-tube stress, and possible chance of component failure. For engine-specific guidelines, see below:

Cummins and Mercedes-Benz engines: A winterfront may be used to improve cab heating while idling, and only when the ambient temperature remains below 10°F (-12°C).

Detroit engines (EPA07 and newer): Use of a winterfront is not recommended. Using a winterfront can cause excessive fan run time, increased fuel consumption, and failure of the DEF system heaters to operate correctly, resulting in fault codes, poor performance, and power reduction. A winterfront should only be used temporarily in the following situations:

- To improve cab heating while idling in an extremely cold ambient temperature;
- When the ambient temperature remains below -22°F (-30°C) and the engine is unable to maintain a running coolant temperature of 175°F (80°C) during normal over-the-road operation.

High-Altitude Operation

Engines lose horsepower when operated at high altitude because the air is too thin to burn as much fuel as at sea level. This loss equals about three percent for each 1000 ft (300 m) altitude above sea level for a naturally aspirated engine.

All engines used on Freightliner vehicles are altitude-compensated by the use of a turbocharger. This reduces smoky exhaust at high altitudes, requires less downshifting, and allows the engine to make better use of its fuel. Nevertheless, shift gears as needed to avoid excessive exhaust smoke.

Engine Shutdown

1. With the vehicle stopped, set the parking brake and place the transmission in neutral.

NOTICE

Idle the engine one to two minutes before shutting it down. After hard operation, shutting down the engine without idling may cause damage to the turbocharger.

2. Allow the engine to idle one to two minutes before shutting it down. This allows the lubricating oil and the coolant to carry heat away from the combustion chambers, bearings, shafts, and seals.

NOTICE

Except in an emergency, do not shut down the engine when the coolant temperature is above 194°F (90°C). To do so could damage the engine.

3. Turn off the ignition switch and shut down the engine.

11

Optional Engine Systems

| | |
|--|------|
| Engine Protection—Warning and Shutdown | 11.1 |
| Engine Idle Limiting | 11.2 |
| Power Takeoff (PTO) Governor | 11.2 |
| Optimized Idle® | 11.2 |

Optional Engine Systems

Engine Protection—Warning and Shutdown

NOTE: The engine warning and shutdown system is present on EPA07-compliant and newer vehicles.

The driver should be familiar with the vehicle warning system in order to bring the vehicle to a safe stop if necessary. If the driver doesn't understand how the warning system works, the driver may not be able to utilize the advantage of the advance warning system to pull over appropriately.

The engine will begin a warning and derate and/or shutdown process if the engine coolant temperature, coolant level, engine oil pressure, or exhaust after-treatment system (ATS) reach preset levels. On some engines, the warning process will begin when the engine oil temperature, engine coolant temperature, or the intake air temperature reach preset levels. Detroit™ engines may also begin the warning and shutdown process if water is detected in the fuel.

See the engine manufacturer's operation manual for specific details for your vehicle. See [Chapter 12](#) for the warning and shutdown modes associated with the ATS.

Electronic engine protection can be specified as either SHUTDOWN or WARNING and DERATE.

WARNING

When the STOP engine or CHECK engine lamp illuminates, most engines are programmed to shut down automatically within 30 seconds. The driver must immediately move the vehicle to a safe location at the side of the road to prevent causing a hazardous situation that could cause bodily injury, property damage, or severe damage to the engine.

In SHUTDOWN mode, the red STOP engine lamp will illuminate when the problem is serious enough to reduce power or speed. See [Fig. 11.1](#). Engine power will ramp down, then the engine will shut down if the problem continues while in derate mode. The driver has 30 or 60 seconds (depending on the critical fault type) after the STOP engine lamp illuminates to move the vehicle safely off the road. If the vehicle cannot be moved to a safe location within that time, turn the ignition switch to OFF for at least five sec-

onds, then restart the engine. Repeat this action until the vehicle is safely off the road.

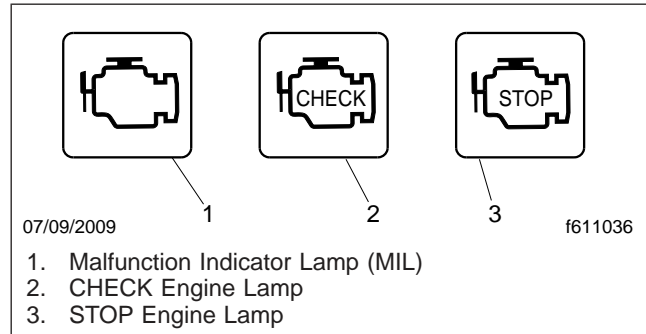

Fig. 11.1, Engine Warning Lamps

Do not operate the vehicle further until the problem causing the shutdown has been corrected.

Some vehicles may have a shutdown override switch, which can be used to momentarily override the shutdown sequence. This switch resets the shutdown timer, restoring power to the level before the derate. The switch must be pressed again after five seconds to obtain a subsequent override. See [Fig. 11.2](#).

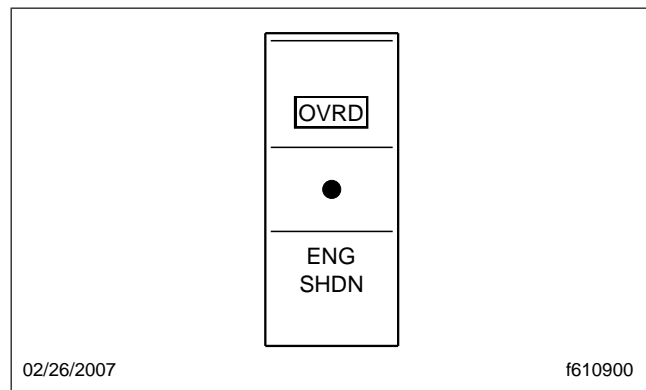

Fig. 11.2, Shutdown Override Switch

NOTICE

When the derate process begins, immediately get the vehicle serviced in order to prevent severe damage to the engine.

Detroit engines may begin a warning and derate process if water is detected in the fuel, or for high engine coolant temperature. In WARNING and DERATE mode, the CHECK engine, STOP engine, or MIL

lamp will illuminate to indicate an engine problem that requires service and the engine controls will begin a derate of engine output. Continuing to run the engine while it is in derate mode could cause severe damage to the engine.

Engine Idle Limiting

Idle Shutdown Timer

This feature is an optional 1- to 100-minute idle shutdown system. Its purpose is to conserve fuel by eliminating excessive idling, and allowing a turbo-charger cool-down period. Idle shutdown timing and parameters are programmable. See the engine manufacturer's operation manual for specific details for your vehicle.

The idle shutdown system requires that the transmission be in neutral with the parking brake set.

California Engine Idle Limiting

In order to meet the California Air Resources Board (CARB) engine idle limit, vehicles are equipped with an engine idle shutdown feature. The automatic shutdown feature is required on all California-certified engines (with the exception of engines used in specific vehicle types that are exempt from the requirement). Owners that wish to have the shutdown feature disabled on vehicles operating in California should consult with California authorities to determine if their vehicle qualifies for the exemption.

When the CARB engine idle limiting feature is enabled, the engine will typically shut down after five minutes of continuous idling with the transmission in neutral or park, and the parking brake set. It will also shut down after 15 minutes with the transmission in neutral or park, and the parking brake off. See the engine manufacturer's operation manual for specific details for your vehicle.

Changing the position of the brake pedal, clutch pedal, accelerator pedal, shutdown override switch, or parking brake during the final 30 seconds will cause the shutdown timer to reset. After an automatic shutdown, the engine may be restarted and operated normally.

Power Takeoff (PTO) Governor

WARNING

To avoid injury, do not install a PTO that is not Detroit Diesel approved onto a Detroit™ Transmission. Use of a non-Detroit Diesel approved PTO with a Detroit Transmission could result in unintended operation which could lead to severe personal injury.

Engine power takeoffs (PTO) tap into engine power to run auxiliary devices, such as hydraulic pumps that power additional equipment. The following are general guidelines for operating a PTO.

1. Set the parking brake and put the transmission in neutral.
2. Press the dash PTO switch. Release the switch when the light begins to blink.

When the light illuminates steadily, the PTO is engaged and ready to operate. In stationary mode, the vehicle must remain in neutral with the parking brake set.

3. To activate mobile mode, shift from neutral to reverse, 1st, or 2nd gear. The clutch will open and the PTO will disengage for a moment.
4. Touch the accelerator pedal to close the clutch and engage the PTO in mobile mode. The PTO may be operated with the transmission in neutral or reverse, and 1st and 2nd gears only.

NOTE: Do not attempt to change gears while the vehicle is moving. The transmission will ignore the request.

5. To deactivate mobile mode, bring the vehicle to a stop. The clutch will open and shut down power to the PTO.
6. To resume stationary mode, shift to neutral. The PTO will engage.
7. To deactivate PTO, press the PTO switch again. When the light in the switch goes out, power to the PTO is shut off.

Optimized Idle®

Optimized Idle reduces engine idle time by running the engine only when required. Optimized Idle automatically shuts down and restarts the engine as

Optional Engine Systems

needed to ensure engine oil temperature remains within factory preset limits, the batteries stay charged, and cab/sleeper temperature remains at the thermostat setting. The benefits of the system include reduced engine idle time, fuel savings, reduction of exhaust emissions and noise, increased starter and engine life, and reduced chance of dead batteries.

Vehicles equipped with Optimized Idle have a label on the dash, and a telltale (OPT IDLE) in the ICU. See [Fig. 11.3](#) for the dash label detail. If equipped, a thermostat is located above the sleeper bunk. See [Fig. 11.4](#).

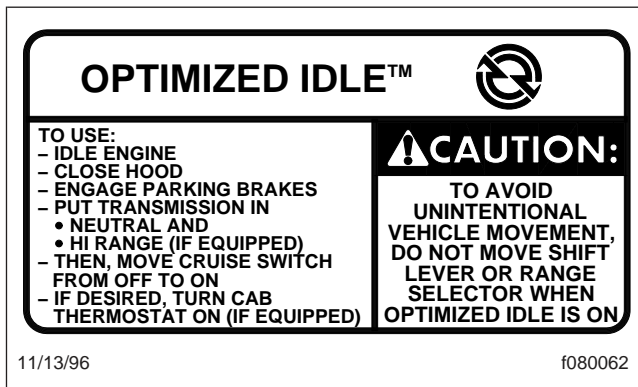

Fig. 11.3, Optimized Idle Dash Label

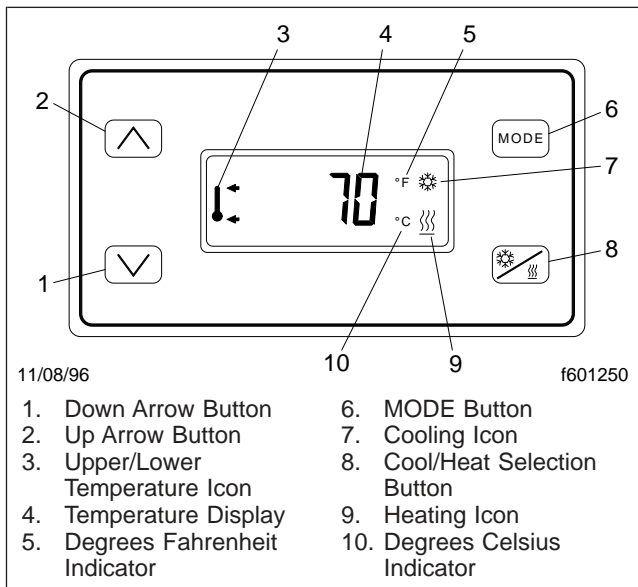

Fig. 11.4, Optimized Idle Thermostat

Optimized Idle operates in two modes:

- Engine mode: Keeps the battery charged and engine oil temperature between 60 and 104°F (16 to 40°C).
- Thermostat mode (activated when the optional thermostat is turned on): Keeps the cab and sleeper at a constant preset temperature, in addition to all functions available in engine mode.

Thermostat mode controls the set point, which is the desired temperature of the cab and sleeper, and the comfort zone, which is the allowed temperature deviation from the set point before the engine starts.

The thermostat display defaults to show the temperature of the sleeper, but changes accordingly as the buttons are pressed.

The button functions are as follows:

- Up arrow: Increases the set point and comfort zone (allowed temperature variation).
- Down arrow: Decreases the set point and comfort zone.
- Cool/Heat: Sets either cooling or heating operation.
- MODE: Scrolls through the various functions. It can also be used to set desired temperature values.

If a vehicle has Optimized Idle, the following functions will not operate with the key in accessory mode. Optimized Idle may also turn these functions off to reduce stress on the batteries.

- Cab climate control fan
- Sleeper climate control fan
- Mirror heat
- Fuel/water separator heat
- Seat heat
- Advertising light
- Auxiliary circulation fan (windshield)
- Air dryer

1. To activate Optimized Idle (engine mode):
 - 1.1 Set the parking brake.
 - 1.2 If it is open, close and secure the hood.

1.3 Start the engine and let it idle.

1.4 Put the transmission in neutral.

1.5 Turn on the cruise control.

The OPT IDLE lamp will blink, indicating that Optimized Idle is active. The system is now in engine mode and after an initial phase, in which the idle speeds up to 1000 rpm, the engine will stop and start automatically to keep the battery charged and the engine oil warm.

IMPORTANT: The cruise control must be turned on once the engine is idling. If it was previously turned on, turn the cruise control off, then turn it on again.

2. Activate thermostat mode, if equipped.

NOTE: When the system is in thermostat mode, it is also in engine mode. It will continue to operate in engine mode even if thermostat mode is turned off.

2.1 With the system in engine mode, set the cab and sleeper heater or air conditioner controls to the highest setting.

2.2 Turn on the thermostat by touching any of the four buttons. See [Fig. 11.4](#).

The display will flash the current sleeper temperature and the previous mode (cooling or heating) selected. If the cab needs to be cooled or heated, the cool/heat icon will flash.

2.3 Choose either cool or heat by pressing the Cool/Heat button. Make sure the selection matches that of the cab controls.

IMPORTANT: If the heat or cool selection of the thermostat does not match that of the cab controls, the system will idle and cycle excessively.

2.4 Select Fahrenheit or Celsius by pressing and holding the MODE button until either the "F" or "C" is displayed.

2.5 Select the temperature set point by pressing the up or down arrows, as applicable. Holding the button will cause the display

to scroll up or down rapidly. When the desired set point is displayed, release the button. The set point is stored in memory.

2.6 Select the temperature comfort zone by pressing the MODE button until the upper and lower temperature limit icon is displayed. Then use the up or down arrow to select one of the three comfort zones: 4°F (2°C), 7°F (4°C), or 10°F (6°C).

3. To deactivate thermostat mode and return to just engine mode, press and hold the MODE button for three seconds.

4. To shut down Optimized Idle completely, either turn off the ignition or use the drive away feature.

The drive away feature allows the use of all the engine features. Use the drive away feature as follows:

4.1 If the engine is running: Release the parking brakes or put the transmission in gear.

If the engine is not running: Start the engine. Release the parking brakes or put the transmission into gear.

4.2 Let the engine return to base idle. The active light will turn off. Optimized Idle is now disabled.

12

Emissions and Fuel Efficient Components

| | |
|---|------|
| Greenhouse Gas Emissions and Fuel Consumption Standards | 12.1 |
| EPA-Regulated Emissions Aftertreatment Systems | 12.1 |
| Diesel Exhaust Fluid and Tank, EPA10 and Newer Engines | 12.3 |

Emissions and Fuel Efficient Components

Greenhouse Gas Emissions and Fuel Consumption Standards

Vehicles and/or engines manufactured after December 31, 2006 and domiciled in the U.S. or Canada are required to meet all EPA and NHTSA regulations effective as of the vehicle build date. Engines manufactured between January 1, 2007 and December 31, 2009 meet EPA07 requirements. Engines manufactured between January 1, 2010 and December 31, 2012 meet EPA10 requirements. Engines manufactured from January 1, 2013 meet NHTSA and EPA 2014 fuel efficiency and greenhouse gas emission standards (GHG14) requirements.

Model year 2013 and later vehicles meet additional requirements as specified by GHG14 requirements. These vehicles are equipped with components that increase fuel efficiency and reduce GHG emissions. Components may include, but are not limited to, low-rolling resistance tires; aerodynamic devices such as hood, cab/sleeper extenders, and fuel tank fairings; vehicle speed limiter; and idle shutdown timer. If replacement of any drag-reducing component is required, the replacement component must meet or exceed the drag reduction performance of the originally installed component in order to maintain compliance with GHG14 requirements.

EPA-Regulated Emissions Aftertreatment Systems

IMPORTANT: Depending on local jurisdictional guidelines, vehicles that are domiciled outside of the U.S. and Canada may not have emissions aftertreatment systems (ATS) that are compliant with EPA regulations.

NOTICE

Follow these guidelines for engines that comply with EPA07 or newer regulations, or damage may occur to the aftertreatment device (ATD) and the warranty may be compromised.

- Use ultralow-sulfur diesel with 15 ppm sulfur content or less.
- Do not use fuel blended with used engine lube oil or kerosene.

- Engine lube oil must have a sulfated ash level less than 1.0 wt %; currently referred to as CJ-4 oil.

IMPORTANT: Using non-specification fuels or oils can lead to shortened diesel particulate filter (DPF) cleaning or replacement intervals. For example, using CJ-4+ oil with 1.3% sulfated ash (30% more ash content) may result in the need for DPF cleaning or replacement 20 to 30% sooner than would normally be required.

IMPORTANT: See the engine manufacturer's operation manual for complete details and operation of the ATS.

EPA07 Engines

Engines built between January 1, 2007 and December 31, 2009 are required to meet EPA07 guidelines for reduced exhaust emissions of particulate matter and nitrogen oxides (NOx). NOx is limited to just over 1 gram per brake horsepower hour (g/bhp-hr), and particulate matter cannot exceed 0.01 g/bhp-hr.

The EPA07 ATS varies according to engine manufacturer and vehicle configuration, but the exhaust muffler is replaced by an aftertreatment device (ATD). Inside the ATD, the exhaust first passes over the diesel oxidation catalyst (DOC), then passes through the diesel particulate filter (DPF), which traps soot particles. The soot is burned to ash during a process called regeneration (regen).

EPA10 and Newer Engines

The EPA mandates that all engines built after December 31, 2009 must reduce the level of emissions exhausted by the engine to the following levels:

- Nitrogen Oxides (NOx) – 0.2 g/bhp-hr
- Particulate Matter (PM) – .01 g/bhp-hr

To meet EPA guidelines, engines that are compliant with EPA10 and newer regulations use an ATS that has, in addition to a DOC/DPF device like that used in an EPA07 ATD, a Selective Catalytic Reduction (SCR) device to reduce NOx downstream of the engine. After exhaust gases leave the DPF, a controlled quantity of diesel exhaust fluid (DEF) is injected into the exhaust stream. In the presence of heat, DEF is converted to ammonia gas, which reacts with NOx in the selective catalyst chamber to yield nitrogen and water vapor, which exit through the tailpipe.

Emissions and Fuel Efficient Components

Regeneration

The harder an engine works, the better it disposes of soot. If the exhaust temperature is high enough, a process called **passive regeneration** (regen) occurs as the vehicle is driven normally. However, if the engine isn't running hot enough, the electronic controls may initiate an **active regen**, whereby extra fuel is injected into the exhaust stream to superheat and reduce the soot trapped in the DPF to ash. Active regen happens only when the vehicle is moving above a certain speed, determined by the engine manufacturer. See your engine operation manual for complete details. Both active and passive regen happen automatically, without driver input.

WARNING

Active regeneration can occur automatically anytime the vehicle is moving. The exhaust gas temperature could reach 1500°F (800°C), which is hot enough to cause a fire, heat damage to objects or materials, or personal injury to persons near the exhaust outlet. The exhaust temperature can remain high even after the vehicle has stopped. When stopping the vehicle shortly after an automatic regen, ensure the exhaust outlets are directed away from structures, trees, vegetation, flammable materials, and anything else that may be damaged or injured by exposure to high heat.

See *Regen Switches*, below, for instructions on preventing automatic regen if necessary.

When operating conditions do not allow for ATD filter cleaning by active or passive regen, the vehicle may require a driver-activated **parked regen**. When this occurs, the DPF lamp illuminates, indicating that a regen is required. The driver must either bring the vehicle up to highway speed to increase the load (thus starting an active regen), or park the vehicle and initiate a parked regen. See *Regen Switches*, below, for instructions on initiating a parked regen.

Regen Switches

The regen request switch, located on the dash, is used to initiate a parked regen. See [Fig. 12.1](#). To access the regen request switch, lift the guard and press the yellow button.

Some vehicles may be equipped with a regen inhibit switch. See [Fig. 12.1](#). To stop a regen in progress or prevent the start of a regen, press the lower half of

the switch. Regen is then delayed until the switch is no longer active.

NOTE: The regen switch can initiate a parked regen only when the DPF lamp is illuminated.

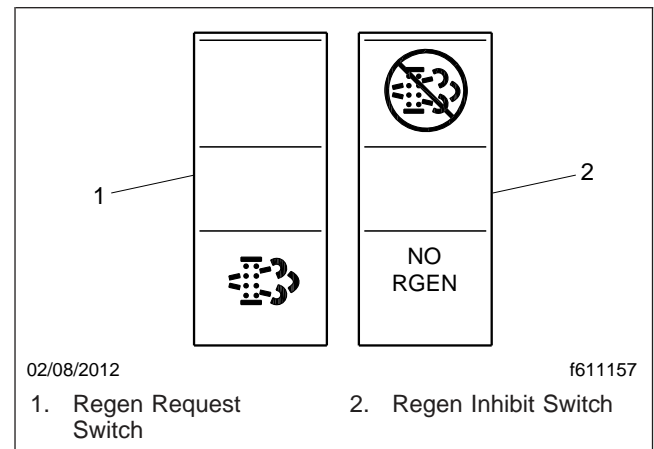

Fig. 12.1, Regen Request and Inhibit Switches

WARNING

During parked regen, exhaust temperatures are very high and could cause a fire, heat damage to objects or materials, or personal injury to persons near the exhaust outlet.

Before initiating a parked regeneration, make certain the exhaust outlets are directed away from structures, trees, vegetation, flammable materials, and anything else that may be damaged or injured by prolonged exposure to high heat.

To initiate a parked regen, perform the following steps.

1. Park the vehicle away from all flammable materials, put the transmission in neutral, and set the parking brake.
2. Start and warm the engine until the coolant temperature is at least 150°F (66°C).
3. Lift the regen request switch guard and press and hold the yellow button for five seconds. As the regen process is initiated, engine rpm increases and the HEST lamp illuminates to indicate extremely high exhaust temperatures.

IMPORTANT: The driver must remain with the vehicle during the entire regen cycle.

Emissions and Fuel Efficient Components

4. The regen cycle will finish after 20 to 60 minutes, at which time engine idle speed drops to normal and the vehicle can be driven normally. The HEST lamp is extinguished when vehicle speed exceeds 5 mph (8 km/h) or the system has cooled to normal operating temperature.
5. To stop a parked regen at any time during the process:
 - depress the clutch pedal, brake pedal, or accelerator pedal;
 - press and hold the regen inhibit switch until idle returns to normal;
 - shut down the engine.

ATS Warning Lamps

There are three warning lamps that alert the driver of high exhaust temperature, the need to perform a parked regen or service the DPF, or of an engine fault that affects emissions. A decal attached to the driver's sun visor explains the ATS warning lamps. [Fig. 12.2](#).

See [Fig. 12.3](#) for an explanation of the ATS warnings, and actions required to avoid engine protection sequences.

Malfunction Indicator Lamp (MIL)

A steadily illuminated yellow malfunction indicator lamp (MIL) indicates an engine fault that affects emissions. See [Fig. 12.4](#).

DPF Status Lamp

When soot accumulates in the DPF and the DPF status lamp illuminates, see [Fig. 12.5](#), perform a parked regen or bring the vehicle up to highway speed to increase the load (thus starting an active regen).

If the DPF status lamp blinks while the CHECK engine lamp is illuminated, initiate a parked regen immediately in order to prevent an engine derate.

If the red STOP engine lamp illuminates with the blinking DPF lamp and the CHECK engine lamp, begin a parked regen in order to prevent an engine shutdown. Park the vehicle and perform a parked regen.

High Exhaust System Temperature (HEST) Lamp

Slow (10-second) flashing of the high exhaust system temperature (HEST) lamp indicates that a parked regen is in progress, and the engine's high idle speed is being controlled by the engine software, not the vehicle driver.

Steady illumination of the HEST lamp alerts the driver of high exhaust temperature during the regen process if the vehicle speed is below 5 mph (8 km/h), or during a parked regen. See [Fig. 12.6](#).

Maintenance

Authorized service facilities must perform any DPF service. For warranty purposes, maintain a record that includes:

- date of cleaning or replacement;
- vehicle mileage;
- particulate filter part number and serial number.

Diesel Exhaust Fluid and Tank, EPA10 and Newer Engines

Diesel Exhaust Fluid

Diesel exhaust fluid (DEF) is used in the ATS to lower NOx in the exhaust stream. DEF is colorless and close to odorless (it may have a slightly pungent odor similar to ammonia). It is nontoxic, nonflammable, and biodegradable. It is mildly corrosive to aluminum, but does not affect the strength or structure of the aluminum.

White crystals may be noticeable around components that come into contact with DEF. The crystals are easily removed with water.

DEF consumption varies depending on ambient conditions and vehicle application.

Freezing Conditions

DEF freezes to slush at around 12°F (-11°C). It is not damaged or destroyed if frozen, and is fully usable when thawed. The DEF in the tank is allowed to freeze while a vehicle is non-operational. At start-up, normal operation of the vehicle is not inhibited if the DEF is frozen; an immersion heater with engine coolant flowing through it warms the DEF once the engine is running, allowing the SCR system to operate.

Emissions and Fuel Efficient Components

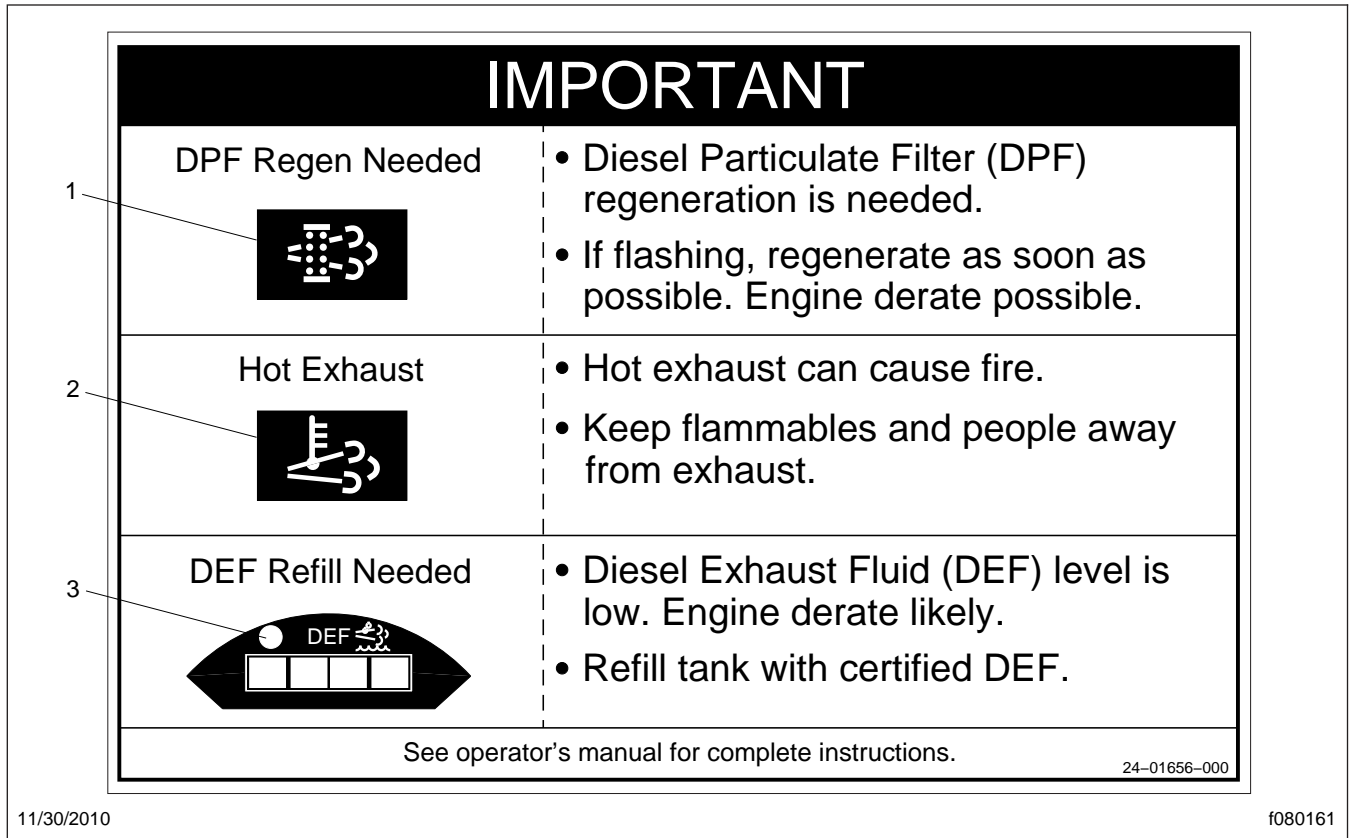

Fig. 12.2, Warning Lamp Decal, Sun Visor

Pre-2013 DEF supply lines are electrically-heated and are purged when the engine is shut down; complete purging of the DEF lines requires approximately five minutes after the engine is shut down.

DEF supply lines with engine model year 2013 and newer are designed to survive freezing conditions while containing DEF, so purging is not required.

DEF Tank

Engines that are compliant with EPA10 and newer regulations are equipped with a DEF tank located on the driver's side of the vehicle behind the battery box or forward of the fuel tank. See [Fig. 12.7](#) and [Fig. 12.8](#). The DEF tank has a 19 mm filler neck inlet that prevents the hose from a diesel outlet from being inserted, and has a blue cap for easy identification.

Fuel/DEF Gauge





The diesel fuel and DEF levels are measured in a dual-purpose gauge. See [Fig. 12.9](#).

Fuel level is indicated at the top of the gauge. Below the fuel level, a low fuel warning lamp illuminates amber when the fuel level drops below 1/8th of the capacity.

The lower portion of the gauge has a DEF warning lamp that illuminates amber when the DEF tank is near empty, and a lightbar that indicates the level of DEF in the tank. The DEF light bar illuminates as follows.

- Four bars illuminated green—Between 75% and 100% full
- Three bars illuminated green—Between 50% and 75% full
- Two bars illuminated green—Between 25% and 50% full

Emissions and Fuel Efficient Components

| EXHAUST AFTERTREATMENT SYSTEM INFORMATION | | | | | |
|---|--|---|---|--|---|
| INDICATOR LAMP(S) |  (Solid) Level 1 |  (Flashing) Level 2 |  (Flashing) CHECK Level 3 |  (Flashing) CHECK STOP Level 4 |  WARNING |
| Indicator Lamp Message(s) | Filter Regeneration Recommended | Filter Regeneration Necessary | Parked Regeneration Required – Engine Derate | Parked Regeneration Required – Engine Shut Down | HEST (High Exhaust System Temperature) |
| Diesel Particulate Filter Condition | Filter is reaching capacity. | Filter is now reaching maximum capacity. | Filter has reached maximum capacity. | Filter has exceeded maximum capacity. | Flashing A regeneration is in progress. |
| Required Action | Bring vehicle to highway speeds to allow for an Automatic Regeneration or perform a Parked Regeneration. | To avoid engine derate bring vehicle to highway speeds to allow for an Automatic Regeneration or perform a Parked Regeneration as soon as possible. | Vehicle must be parked and a Parked Regeneration must be performed – engine will begin derate. | Vehicle must be parked and a Parked Regeneration or Service Regeneration must be performed. Check engine operator's manual for details –engine will shut down. | Solid Exhaust Components and exhaust gas are at high temperature. When stationary, keep away from people and flammable materials or vapors. |
| For a driver performed Parked Regeneration, vehicle must be equipped with a dash mounted Regeneration Switch. | | | | | |
| See Engine Operator's Manual for complete Regeneration Instructions. | | | | | <small>24-01583-0008</small> |

06/29/2009

f080147

Fig. 12.3, ATS Warning Lamps

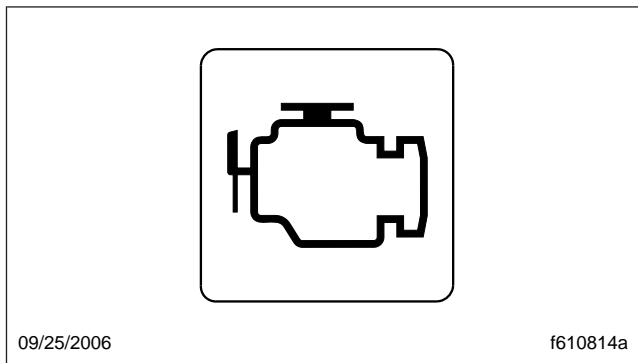

Fig. 12.4, Malfunction Indicator Lamp (MIL)

- One bar illuminated green—Between approximately 10% and 25% full
- One bar illuminated amber—DEF very low, refill DEF
- One bar flashing red—DEF empty, refill DEF

DEF Warnings and Engine Limits

IMPORTANT: Ignoring the DEF warning lights results in limited engine power, with the application of a 5 mph (8 km/h) speed limit.

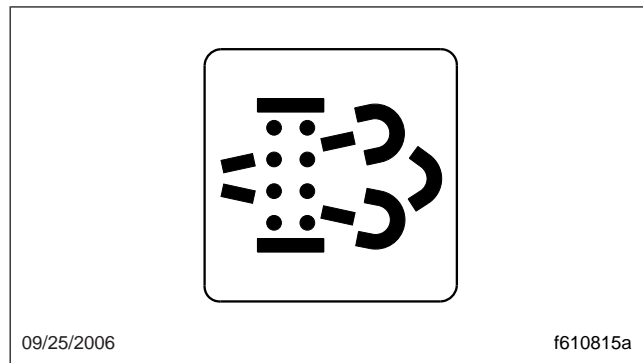

Fig. 12.5, DPF Status Lamp

DEF Level Low—Initial Warning

When the DEF level is low, the following lamps notify the driver. See Fig. 12.10. Refill the DEF tank in order to cancel the warning sequence.

- One bar of the DEF level indicator illuminates amber—DEF very low, refill DEF.
- The DEF warning lamp illuminates solid amber.

Emissions and Fuel Efficient Components

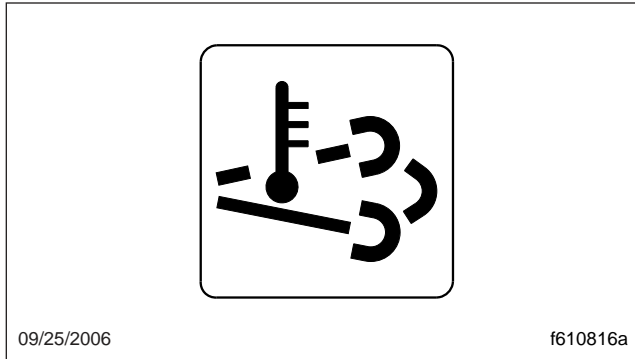

Fig. 12.6, HEST Lamp

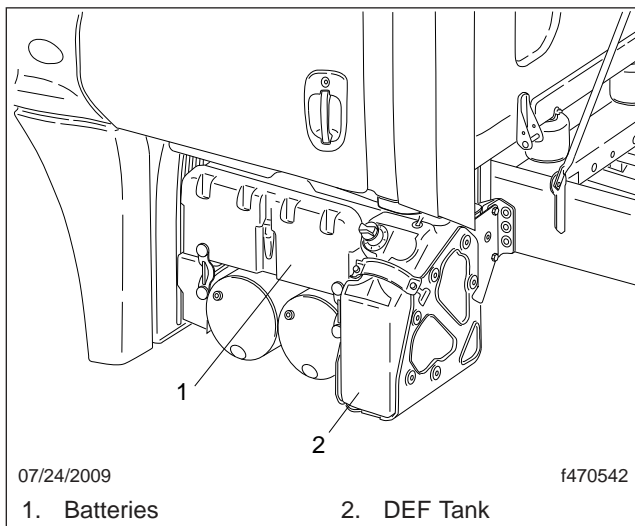

Fig. 12.7, DEF Tank Located Behind the Battery Box

DEF Empty

When the DEF level reads empty, the following lamps notify the driver. See [Fig. 12.11](#).

- One bar of the DEF level indicator flashes red—DEF empty, refill DEF.
- The DEF warning lamp flashes amber.
- The MIL lamp illuminates.

Pre-2013 Detroit engines: Power is limited, with a 55 mph (90 km/h) speed limit.

Cummins and 2013 Detroit engines: Power is limited with progressively harsher engine power limits applied.

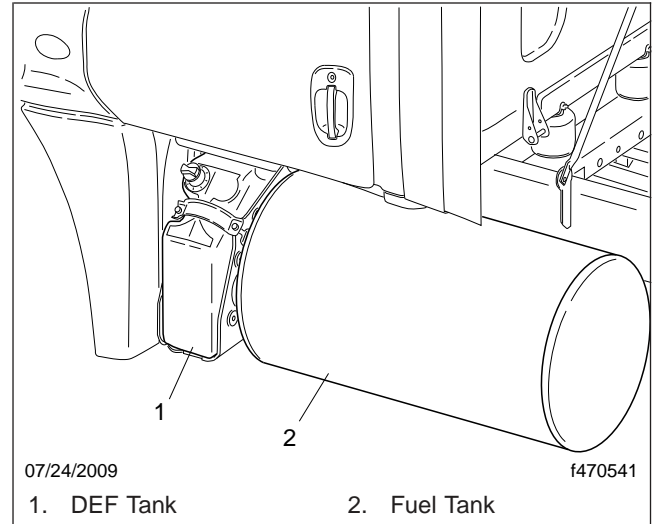

Fig. 12.8, DEF Tank Located Forward of the Fuel Tank

DEF Tank Empty and Ignored

If the empty warning is ignored and the DEF tank is not refilled, the red STOP engine lamp illuminates in addition to the MIL lamp and CHECK engine lamp (on vehicles with a Cummins ISB or ISC/L engine.) See [Fig. 12.12](#).

If the DEF is not refilled, a 5 mph (8 km/h) speed limit is applied after the next engine shutdown, while parked and idling, or if a fuel refill is detected.

DEF Contamination or SCR Tampering

NOTICE

Once contaminated DEF or tampering has been detected, the vehicle must be taken to an authorized service facility to check the SCR system for damage and to deactivate the warning lights and engine limits.

If contaminated DEF or tampering with the ATS is detected, the DEF warning light flashes and the MIL lamp illuminates to warn the driver. The CHECK engine lamp also illuminates on vehicles with a Cummins ISB or ISC/L engine. See [Fig. 12.12](#).

- Detroit engines: Engine power is limited with progressively harsher limits applied. If the fault

Emissions and Fuel Efficient Components

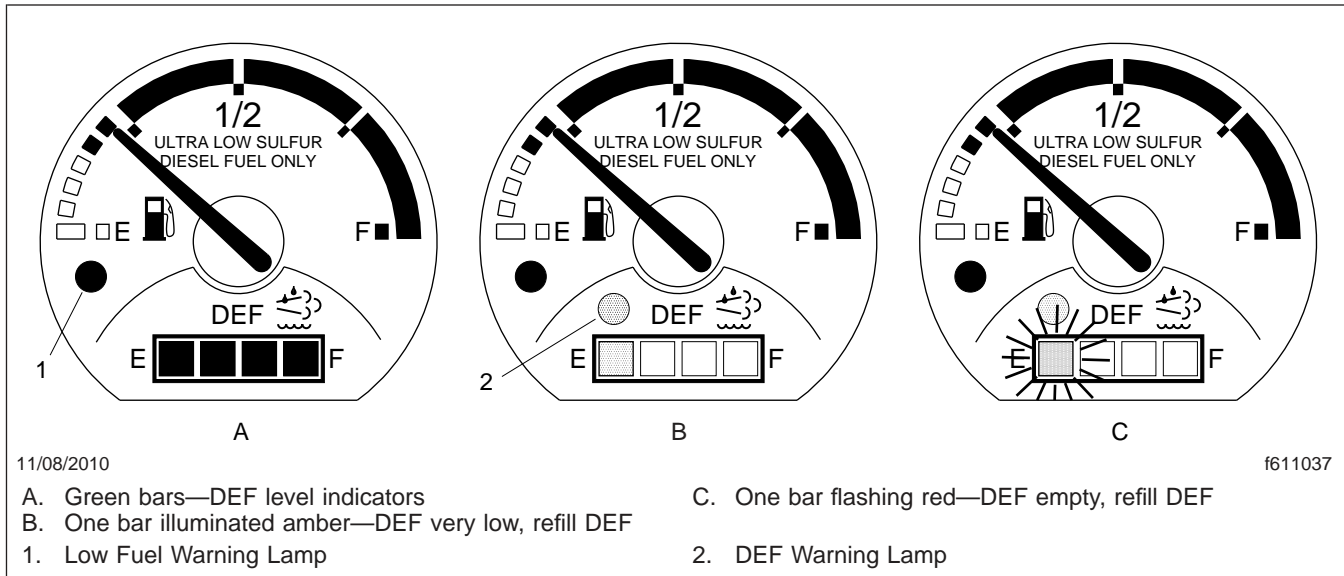

Fig. 12.9, Fuel/DEF Gauge

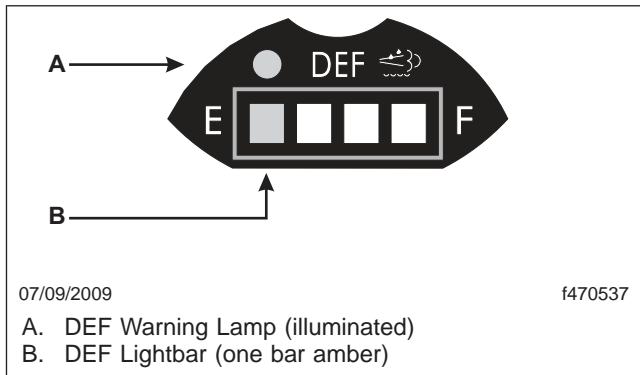

Fig. 12.10, DEF Level Low Initial Warning

is not corrected, the STOP engine light illuminates and a 5 mph (8 km/h) speed limit is applied after the next engine shutdown, while parked and idling, or if a fuel refill is detected.

- Cummins engines: Engine power is limited with progressively harsher limits applied. If the fault is not corrected, the STOP engine light illuminates and a 5 mph (8 km/h) speed limit is applied after the next engine shutdown, or while parked and idling.

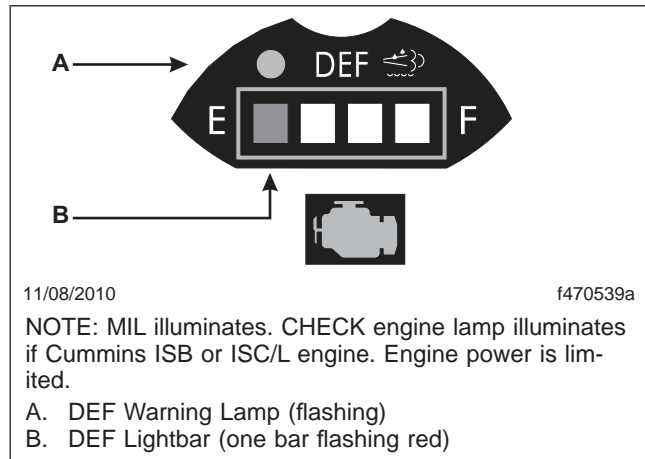

Fig. 12.11, DEF Empty Warning

Emissions and Fuel Efficient Components

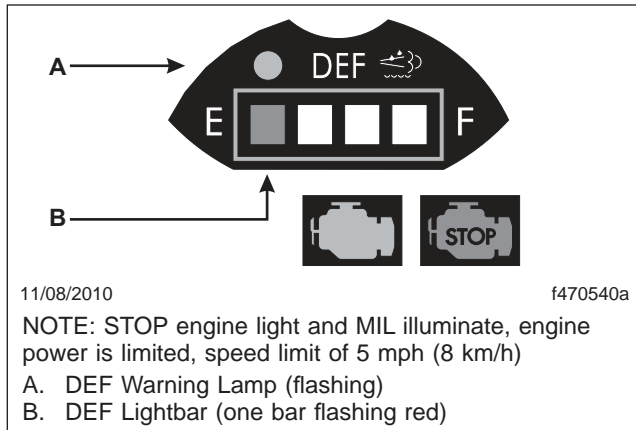

Fig. 12.12, DEF Empty and Ignored Warning

13

Brake Systems

| | |
|--|------|
| Air Brake System | 13.1 |
| Meritor WABCO® Antilock Braking System | 13.3 |
| Engine Brake | 13.5 |

Brake Systems

Air Brake System

Brake System General Information

A dual air brake system consists of two independent air systems that use a single set of brake controls. Each system has its own reservoirs, plumbing, and brake chambers. The primary system operates the service brakes on the rear axle; the secondary system operates the service brakes on the front axle. Service brake signals from both systems are sent to the trailer.

WARNING

Do not operate the vehicle with the front brakes backed off or disconnected. Backing off or disconnecting the front brakes will not improve vehicle handling and may lead to loss of vehicle control, resulting in property damage or personal injury.

Brake System Components

The warning light and buzzer come on if air pressure drops below approximately 70 psi (483 kPa) in either system. If this happens, check the air pressure gauges to determine which system has low air pressure. Although the vehicle's speed can be reduced using the foot brake control pedal, either the front or rear service brakes will not be operating at full capacity, causing a longer stopping distance. Bring the vehicle to a safe stop and have the air system repaired before continuing.

IMPORTANT: In the event of a total loss of service brakes with full system air pressure, use the parking brake control valve (yellow knob) to bring the vehicle to a complete stop in the safest location possible.

Before a vehicle with insufficient system air pressure can be moved, the spring parking brakes must be released by applying an external air source at the gladhands, or by manually caging the parking brake springs.

WARNING

Do not release the spring parking brakes and then drive the vehicle. There would be no means of stopping the vehicle, which could result in serious personal injury or vehicle damage. Before

releasing the spring parking brakes, make the connection to a towing vehicle or chock the tires.

After correcting the brake system problem, uncage the spring parking brakes before resuming normal vehicle operation.

Primary Air Brake System

Loss of air pressure in the primary air system causes the rear service brakes to become inoperative. The secondary air system will continue to operate the front brakes and the trailer brakes (if equipped).

Secondary Air System

Loss of air pressure in the secondary air system causes the front axle brakes to become inoperative. The primary air system will continue to operate the rear service brakes and the trailer brakes (if equipped).

Brake System Operation

Before driving your vehicle, allow time for the air compressor to build up a minimum of 100 psi (689 kPa) pressure in both the primary and secondary systems. Monitor the air pressure system by observing the air pressure gauges and the low-air-pressure warning light and buzzer. The warning light and buzzer shut off when air pressure in both systems reaches approximately 70 psi (483 kPa).

IMPORTANT: Before driving the vehicle, secure all loose items in the cab so that they will not fly forward during a full brake application. Make sure all passengers are wearing seat belts.

During normal brake stops, depress the foot brake control pedal until braking action slows down the vehicle. Increase or decrease the pressure on the pedal so that the vehicle comes to a smooth, safe stop. Apply the spring parking brakes if the vehicle is to be parked.

IMPORTANT: An air brake proportioning system may be used in tractor air brake systems when the vehicle is not equipped with antilock braking system (ABS). When operating in bobtail mode, the rear brake chambers (on which the axle load has been greatly reduced) receive reduced (proportional) air pressure, while the front axle brake chambers receive full (normal) air pressure. This results in a different brake pedal "feel," as the pedal seems to require more travel

and/or effort to slow or stop the vehicle. However, the air brake proportioning system actually improves vehicle control when the tractor is in bobtail mode. When the tractor is towing a trailer, the rear brake chambers will receive full (normal) application air pressure.

When parking a vehicle attached to a trailer that does not have spring parking brakes, apply the tractor parking brakes. Chock the trailer tires before disconnecting the vehicle from the trailer.

WARNING

If a trailer or combination vehicle is not equipped with spring parking brakes, do not park it by pulling out only the trailer air supply valve knob. This would apply only the trailer service brakes. If air were to bleed from the trailer brake system, the trailer brakes would release, possibly causing an unattended runaway vehicle.

NOTICE

Never apply the service and spring parking brakes simultaneously. To do so transmits excessive input force to the brake components, which could damage or cause eventual failure of brake actuating components.

Brake Controls

The trailer brake lever (hand control valve) is used for applying the trailer brakes without applying the truck or tractor service brakes. It is usually mounted on the right-hand control panel. See Fig. 13.1. The valve can be partially or fully applied, but in any partially on position it will be overridden by a full application of the service brake pedal. Moving the lever down applies the trailer brakes, while moving it up releases the trailer brakes. The lever will automatically return to the up position when it is released.

WARNING

Do not use the trailer service brakes for parking; they are not designed for this purpose. If air bleeds out of the trailer air tank during parking, the vehicle could roll, causing serious personal injury or property damage.

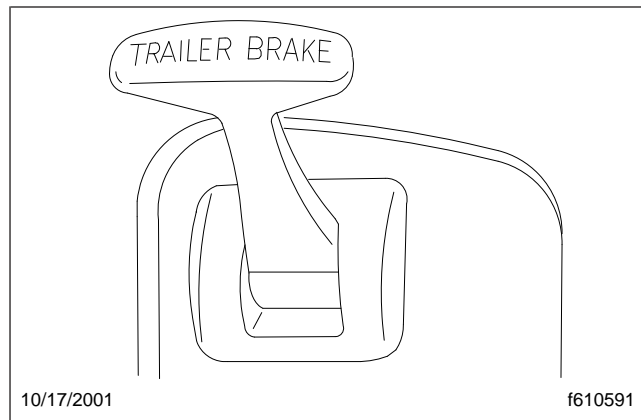

Fig. 13.1, Trailer Brake Lever

The red octagonal-shaped knob in the control panel actuates the trailer air supply valve. See Fig. 13.2. After the vehicle's air hoses are connected to a trailer and the pressure in both air systems is at least 65 psi (448 kPa), the trailer air supply valve must be pushed in. It should stay in to charge the trailer air supply system and to release the trailer spring parking brakes.

Pull the trailer air supply valve out before disconnecting a trailer or when operating a vehicle without a trailer. If pressure in both air systems drops to 35 to 45 psi (242 to 310 kPa), the trailer air supply valve automatically pops out, exhausting the trailer air supply, and applying the trailer service or spring parking brakes.

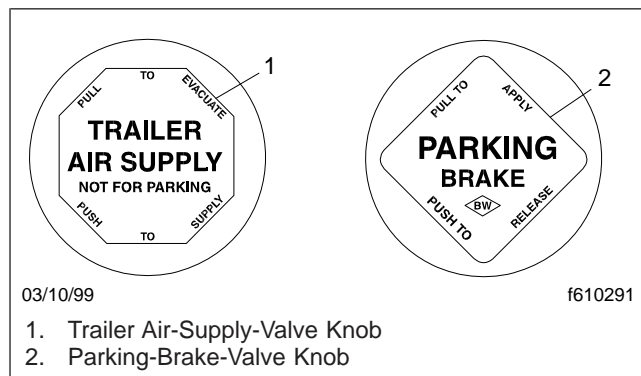

Fig. 13.2, Brake Valve Knobs

The yellow diamond-shaped knob in the control panel actuates the parking brake valve. See Fig. 13.2. Pulling out the parking brake valve applies both the tractor and trailer spring parking brakes and

Brake Systems

automatically causes the trailer air supply valve to pop out.

NOTICE

Do not use the spring parking brakes if the service brakes are hot, such as after descending a steep grade. To do so could damage the brakes. Allow hot brakes to cool before using the spring parking brakes.

Do not use the spring parking brakes during freezing temperatures if the service brakes are wet. To do so could cause them to freeze. If the brakes are wet, drive the vehicle in low gear and lightly apply the brakes to heat and dry them.

If the trailer is not equipped with spring parking brakes, pulling out the parking brake valve applies the tractor spring parking brakes and the trailer service brakes. When the tractor and trailer parking brakes (or trailer service brakes) are both applied, the trailer brakes are released by pushing in the trailer air supply valve, leaving the tractor parking brakes applied. Air pressure in the primary or secondary reservoir must be at least 65 psi (447 kPa) before the tractor spring parking brakes, or the trailer service or spring parking brakes, can be released.

Automatic Slack Adjusters

Automatic slack adjusters should never be manually adjusted except during routine maintenance of the foundation brakes (e.g., replacing shoes), during slack adjuster installation, or in an emergency situation.

When the brake pushrod stroke exceeds the legal brake adjustment limit on a vehicle, there is likely a mechanical problem with the foundation brake components or the adjuster is improperly installed.

Visit a repair facility as soon as possible when brakes equipped with automatic slack adjusters are determined to be out of adjustment.

WARNING

Manually adjusting an automatic slack adjuster to bring the pushrod stroke within legal limits is likely masking a mechanical problem. Adjustment is not a repair. Before adjusting an automatic slack adjuster, troubleshoot the foundation brake system and inspect it for worn or damaged com-

ponents. Improperly maintaining the vehicle braking system may lead to brake failure, resulting in property damage, personal injury, or death.

Meritor WABCO® Antilock Braking System

The Meritor WABCO Antilock Braking System (ABS) is an electronic wheel speed monitoring and control system that works with the standard air brake system. ABS passively monitors vehicle wheel speed at all times, and controls wheel speed during emergency stops.

IMPORTANT: For proper ABS system operation, do not change tire sizes. The sizes of the tires installed during production are programmed into the electronic control unit. Installing different-sized tires could result in a reduced braking force, leading to longer stopping distances.

ABS includes signal-generating tone wheels and sensors located in the wheel hubs of each sensed wheel. The sensors transmit vehicle wheel speed information to an electronic control unit (located behind the center dash). The control unit's main circuit interprets the speed sensor signals and calculates wheel speed, wheel retardation, and a vehicle reference speed. If the calculations indicate wheel lockup, the main circuit signals the appropriate modulator valve to reduce braking pressure. During emergency braking, the modulator valve alternately reduces, increases, or maintains air pressure supply in the brake chamber to prevent front and rear wheel lockup.

The electronic control unit (ECU) also has a safety circuit that constantly monitors the wheel sensors, traction control valve (if equipped), modulator valves, and the electrical circuitry.

The Meritor WABCO ABS combines one front-axle control channel with one rear-axle control channel to form one control circuit. For example, the sensor and modulator valve on the left-front axle form a control circuit with the sensor and modulator valve on the right-rear axle. If, during vehicle operation, the safety circuit senses a failure in any part of the ABS, the tractor warning lamp (TRACTOR ABS) illuminates and the control circuit where the failure occurred is switched to normal braking action. The remaining control circuit will retain the ABS effect. Even if the ABS is completely inoperative, normal braking ability

is maintained. An exception would be if a modulator valve (or combination modulator valve) is damaged and inoperative. As these components are an integral part of the air brake system, normal braking may be impaired or inoperative.

During emergency or reduced-traction stops, fully depress the brake pedal until the vehicle comes to a safe stop. *Do not pump the brake pedal.* With the brake pedal fully depressed, the ABS will control all wheels to provide steering control and a reduced braking distance.

Although the ABS improves vehicle control during emergency braking situations, the driver still has the responsibility to change driving styles depending on existing traffic and road conditions. For example, the ABS cannot prevent an accident if the driver is speeding or following too closely.

Trailer ABS Compatibility

The Meritor WABCO ABS is designed to communicate with a trailer ABS, if they are compatible. Compatibility will result in the illumination of the TRAILER ABS lamp during vehicle start-up and fault detection.

The TRAILER ABS lamp will not illuminate unless a compatible trailer is connected to the tractor. The dash-mounted lamp will operate as follows when a compatible trailer is properly connected to the tractor:

- When the ignition key is turned to the ON position, the TRAILER ABS lamp will illuminate momentarily, then turn off.
- If the lamp illuminates momentarily during vehicle operation, then shuts off, a fault was detected and corrected.
- If the lamp illuminates and stays on during vehicle operation, there is a fault with the trailer ABS. Repair the trailer ABS system immediately to ensure full antilock braking capability.

IMPORTANT: If a compatible trailer is connected, and the lamp is not illuminating momentarily when the ignition key is turned to the ON position, it is possible that the lamp is burnt out.

Automatic Traction Control

Vehicles with electronic engines and ABS may have Automatic Traction Control (ATC). On these vehicles, the ATC system automatically limits wheel spin dur-

ing reduced-traction situations. In normal braking applications, the standard air brake system is in effect.

An additional solenoid valve is installed. During reduced-traction situations, the ATC solenoid valve controls air pressure to the modulator valves and they in turn increase, hold, or reduce pressure to the appropriate brake chambers to provide better traction whenever wheel spin occurs.

When the ATC system is in the NORMAL mode, it will apply gentle braking to the spinning wheel, to feed power to the wheel(s) with better traction. If both wheels are spinning, the system will signal the engine to reduce power.

ATC includes a deep snow and mud option to increase available traction on extra soft surfaces like snow, mud, or gravel. A rocker switch labeled ATC will be located on the dash. Pressing the switch will temporarily allow more drive wheel spin. The activation of the deep snow and mud option is indicated by a flashing WHEEL SPIN lamp. Pressing the switch again will cycle the system back to normal operation.

NOTICE

The deep snow and mud option is intended to be used under specific slippery conditions that require momentary increased wheel spin. Using this option for an extended period of time may damage the vehicle brake system.

After the ignition switch is turned on, the TRACTOR ABS lamp and the WHEEL SPIN indicator lamp come on for about three seconds. After three seconds, the warning lights go out if all of the tractor's ABS components are working.

IMPORTANT: If any of the ABS warning lights do not work as described above, or come on while driving, repair the ABS immediately to ensure full antilock braking capability.

ECAS Automatic Load Transfer (ECAS only)

On those vehicles equipped with Electronically Controlled Air Suspension (ECAS), ECAS works in conjunction with ABS. When wheel slippage is detected by the ABS, the ECAS system transfers weight from the tag axle to the drive axle by changing air pressures in the suspension air bellows, increasing drive wheel traction.

Brake Systems

Engine Brake

Each engine manufacturer uses a specific engine brake for their engine. Regardless of the manufacturer, the engine brake is operated with the principles outlined in here. Refer to the engine manufacturer's operation manual for details of their particular engine brake product.

WARNING

To avoid injury from loss of vehicle control, do not activate the engine brake system under the following conditions:

- **on wet or slippery pavement, unless the vehicle is equipped with antilock braking system (ABS) and you have had prior experience driving under these conditions;**
- **when driving without a trailer or pulling an empty trailer;**
- **if the tractor drive wheels begin to lock, or there is fishtail motion after the engine brake is activated.**

NOTE: When the engine brake is enabled, the engine brake lamp illuminates in the ICU. See [Fig. 13.3](#), Item 1.

Whenever vehicle braking is required on good road conditions, the engine brake may be used in conjunction with the service brakes. There is no time limit for operation of the engine brake. However, an engine brake does not provide the precise control of, and is not a substitute for, service brakes.

WARNING

Usage of the engine brake as the primary braking system can cause unpredictable stopping distances, that could result in personal injury or property damage. Service brakes are the primary vehicle braking system.

Since the engine brake is most effective at rated engine speed, gear selection is very important. Gearing down the vehicle within the limits of the rated engine speed makes the engine brake more effective. Recommended engine braking speed is above 1800 rpm and below the rated speed.

WARNING

The engine brake must be disengaged when shifting gears using the clutch pedal. If the engine brake is engaged when the transmission is in neutral, the braking power of the engine brake can stall the engine, which could result in loss of vehicle control, possibly causing personal injury and property damage.

"Control speed" is the speed at which the engine brake performs 100 percent of the required downhill braking, resulting in a constant speed of descent. The control speed varies, depending on vehicle weight and the downhill grade.

For faster descent, select a higher gear than that used for control speed. Service brakes must then be used intermittently to prevent engine overspeed and to maintain desired vehicle speed.

For slower descent, select a lower gear, being careful not to overspeed the engine. Occasional deactivation of the engine brake may be necessary to maintain the designated road speed under these conditions.

If the engine is equipped with both cruise control and an engine brake, the engine brake can operate automatically while cruise control is activated. The maximum amount of braking is selected with the engine brake control. When the vehicle returns to the set cruise speed, the engine brake will turn off.

The engine brake will only operate when the accelerator and clutch pedals are fully released.

Vehicles equipped with ABS have the ability to turn the engine brake off if wheel slip is detected. The engine brake will automatically turn back on once wheel slip is no longer detected.

Engine Brake Operation

NOTICE

Do not allow the engine to exceed its governed speed, or serious engine damage could result.

NOTE: Depending on the brake type, the engine brake may be disabled when engine temperature falls below a set level.

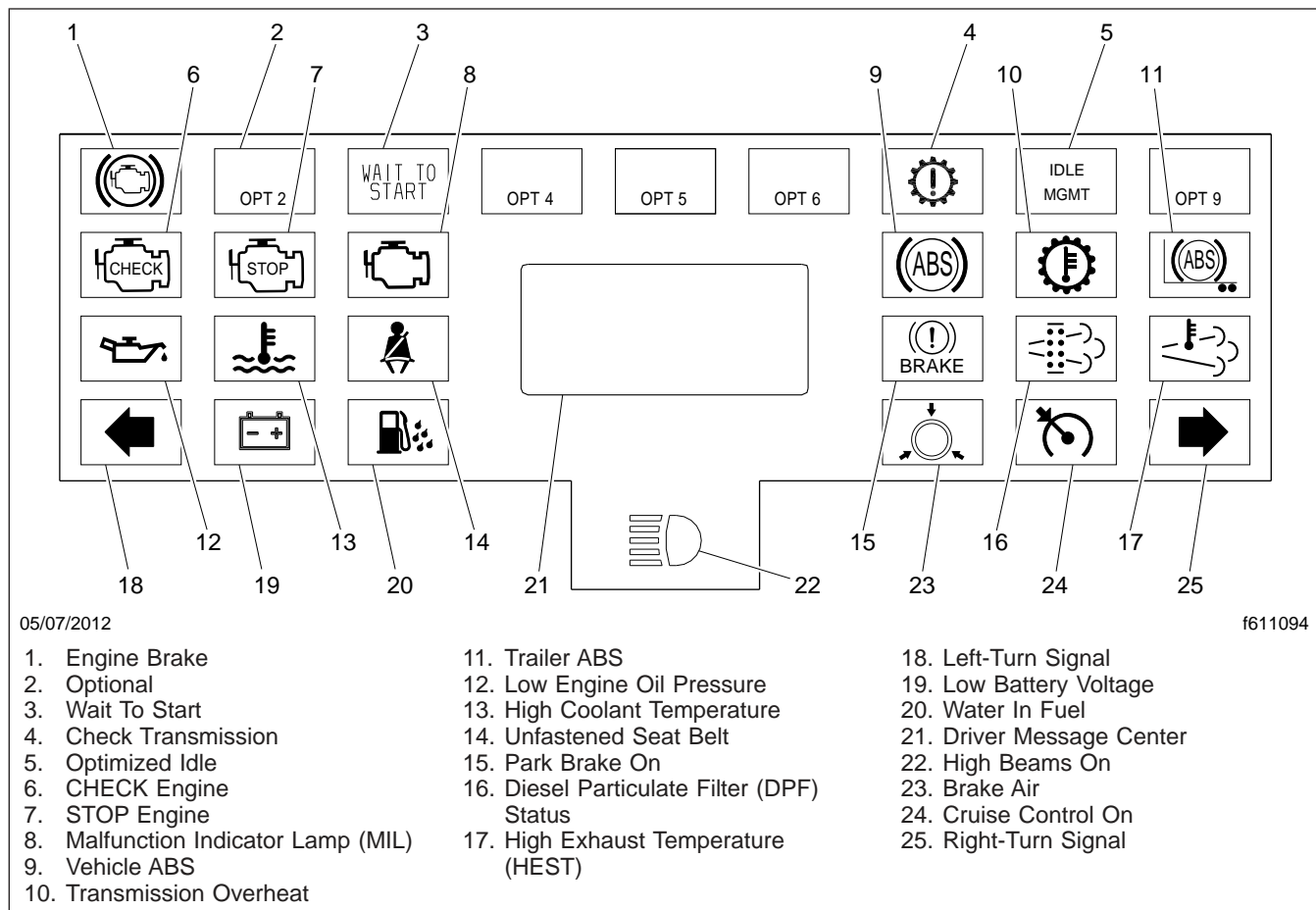

Fig. 13.3, ICU3 Message Center (typical)

The engine brake control depends on vehicle configuration. On some vehicles, there is an engine brake (ENG BRK) switch located in the right-hand pod on the steering wheel that is used to turn the engine brake on and off, and an engine brake level switch on the dash used to set the intensity—high, medium, or low. See [Fig. 13.4](#) and [Fig. 13.5](#).

On vehicles equipped with a column-mounted Detroit multifunction control, the engine brake is controlled by the lever position, as shown in [Fig. 13.6](#). At the top position, the engine brake is off, and at the three lower positions, the engine brake is on and the intensity (low, medium, high) increases with each step down.

NOTE: On vehicles equipped with a Detroit multifunction control, setting the engine brake with the cruise control set activates Deceleration

Mode. Setting the cruise control while the engine brake is on activates Descent Control Mode. For information on these modes, see "Cruise Control" in [Chapter 5](#).

On vehicles equipped with an engine brake switch in the right-hand pod on the steering wheel, operate the engine brake after the engine is warmed up and the vehicle is in motion, as follows:

1. Remove feet from both the clutch and accelerator pedals.
2. Press the upper half of the on/off switch (see [Fig. 13.4](#)) to turn the engine brake on. The engine brake will engage at the rate last set on the engine brake intensity switch and the engine brake lamp will illuminate.

Brake Systems

3. Press the upper or lower half of the intensity switch (see Fig. 13.5) to select the desired braking intensity.

Use the intensity switch set at the LOW position when driving on flat, open stretches of road. If the service brakes are still required to slow down on a grade, switch to a higher setting on the dash switch to maintain constant speed of descent. Grade descent speed should be such that the service brakes are used infrequently and remain cool, thus retaining their effectiveness.

4. For maximum retarding, maintain the top governed speed of the engine through the appropriate selection of gears. When shifting gears, the engine brake will disengage when the clutch pedal is depressed, then engage when the clutch pedal is released.
5. To cancel the engine brake application, press the lower half of the on/off switch.

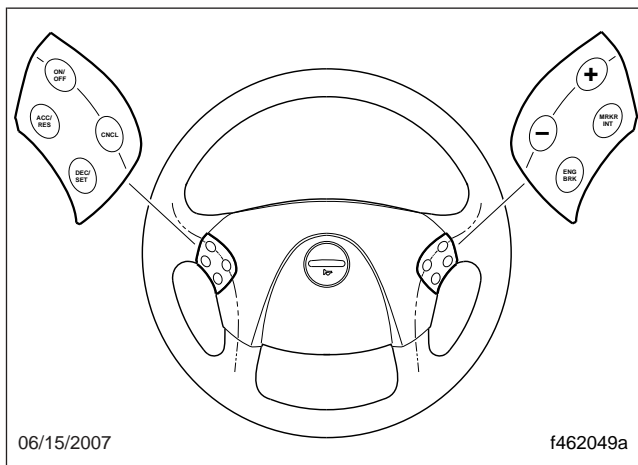

Fig. 13.4, Steering Wheel Switches

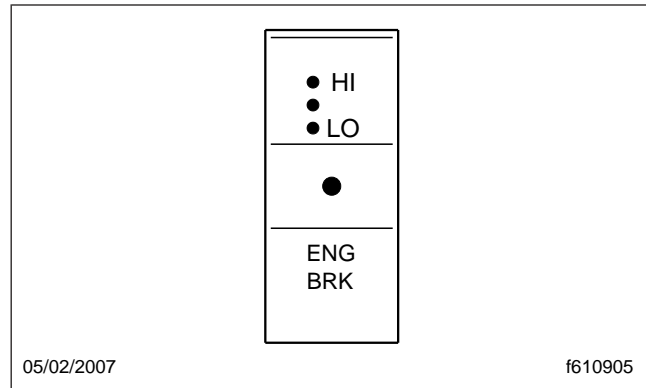

Fig. 13.5, Engine Brake Level Switch

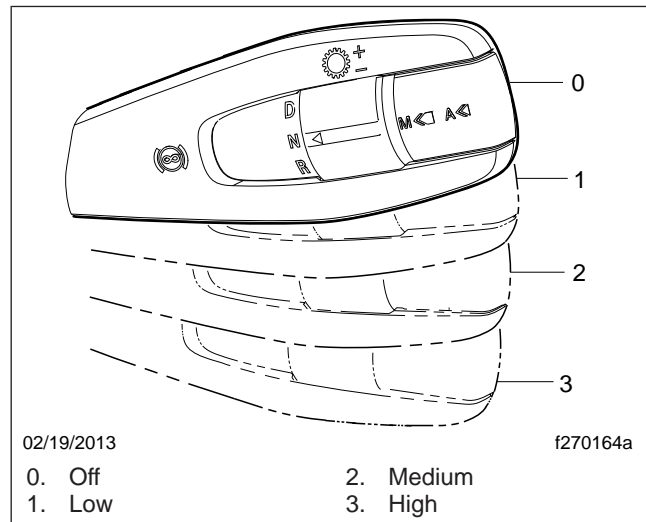

Fig. 13.6, Engine Brake Positions, Detroit Multifunction Control

14

Manual Transmissions and Hydraulic Clutch

| | |
|---|------|
| Eaton Fuller 13-Speed and 18-Speed Splitter and Range-Shift Transmissions | 14.1 |
| Eaton Fuller 10-Speed Range-Shift Transmissions | 14.4 |
| Clutch | 14.5 |

Manual Transmissions and Hydraulic Clutch

Eaton Fuller 13-Speed and 18-Speed Splitter and Range-Shift Transmissions

Refer to the Eaton website for additional information, www.roadranger.com.

General Information, Eaton Fuller Splitter and Range-Shift

Combination splitter and range-shift transmissions allow the choice of two splitter ratios in each lever position as well as the additional ratio provided in each lever position after shifting to the other range.

IMPORTANT: Not all lever positions are used in each range and the shift patterns vary between transmissions. Be sure to read the shift pattern decal on the dash for the operating instructions for the specific transmission installed in your vehicle.

13-Speed RTLO Models

Eaton Fuller 13-speed transmissions have thirteen forward speeds and two reverse speeds. Each transmission consists of a 5-speed front section, and a 3-speed auxiliary section. The auxiliary section contains low- and high-range ratios, plus an overdrive splitter gear. See **Fig. 14.1** for the shift pattern.

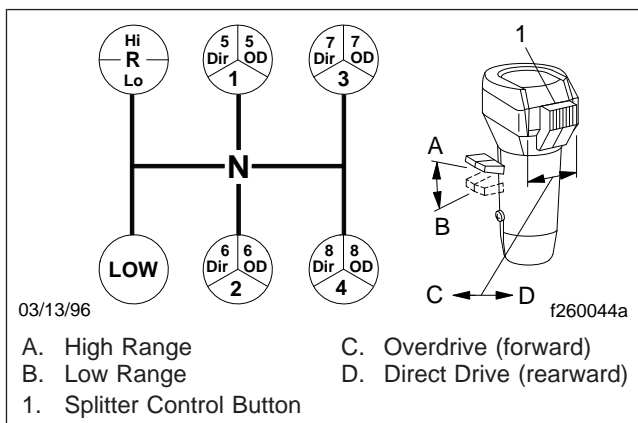

Fig. 14.1, Eaton Fuller 13-Speed Transmission Shift Pattern

All of the 13 speeds are controlled with one shift lever. A range preselection lever and a splitter control button are built into the shift knob. The range pre-

selection lever controls range selection and the splitter control button (located on the side of the shift knob) controls gear splits.

Low gear in the front section is used only as a starting ratio. The remaining four forward positions are used once in the low range and once in the high range. However, each of the four high range gear positions can be split with the underdrive ratio (RT models), or overdrive ratio (RTO models) of the splitter gear. Ratios cannot be split while the transmission is in low range.

18-Speed RTLO Splitter and Range-Shift Models

Eaton Fuller 18-speed transmissions have 18 forward speeds and four reverse speeds. These transmissions consist of a 5-speed front section and a 3-speed auxiliary section. The auxiliary section contains low and high range ratios, plus an overdrive splitter gear.

One ratio in the front section (low) is used as a starting ratio; it is never used when the transmission is in high range. Low gear can be split to provide both a direct and an overdrive ratio.

The other four ratios in the front section are used once in low range and once again in high range; however, each of the five ratios (low-1-2-3-4) in low range and each of the four ratios (5-6-7-8) in high range can be split with the overdrive splitter gear.

All of the 18 speeds are controlled with one shift lever. A range preselection lever and a splitter control button are built into the shift knob. The range preselection lever controls range selection and the splitter control button (located on the side of the shift knob) controls gear splits.

Operation, Eaton Fuller Splitter and Range-Shift

IMPORTANT: The shifter knob has an interlock feature that prevents the splitter control button from being moved forward when the range preselection lever is down (in low range); when in high range and the splitter control button is in the forward position, the range preselection lever cannot be moved down.

Manual Transmissions and Hydraulic Clutch

1. When operating off-road, or under adverse conditions, always use low gear when starting to move the vehicle forward.

When operating on-highway, with no load, or under ideal conditions, use 1st gear when starting to move the vehicle forward.

For all conditions, use the highest gear that is still low enough to start the vehicle moving with the engine at or near idle speed, and without slipping the clutch excessively.

2. Use the clutch brake to stop gear rotation when shifting into low (or 1st) or reverse when the vehicle is stationary. The clutch brake is actuated by depressing the clutch pedal all the way to the floor.

For normal upshifts and downshifts, only a partial disengagement of the clutch is necessary to break engine torque.

3. Use double-clutching between all upshifts and downshifts that require movement of the shift lever. Splitting of the high range gears does not require movement of the shift lever.
4. Never move the shift lever into low gear while in high range.
5. Never move the splitter control button while in neutral.
6. Do not preselect with the splitter control button; after moving the control button, complete the shift immediately.
7. Except when downshifting from 5th direct to 4th gear, never push the range preselection lever down into low range while operating in high range—the splitter will become inoperative.
8. Do not shift from high range to low range at high vehicle speeds.
9. Do not make range shifts with the vehicle moving in reverse gear.
10. Never attempt to move the range preselection lever with the gear shift lever in neutral while the vehicle is moving. Preselection with the range preselection lever must be made prior to moving the shift lever out of gear into neutral.
11. After your shifting ability improves, you may want to skip some of the ratios. This may be done

only when operating conditions permit, depending on the load, grade, and road speed.

Upshifting

1. Position the gear shift lever in neutral. Start the engine, and bring the air system pressure up to 100 to 120 psi (689 to 827 kPa).
2. Position the range preselection lever down, into low range. See [Fig. 14.2](#).

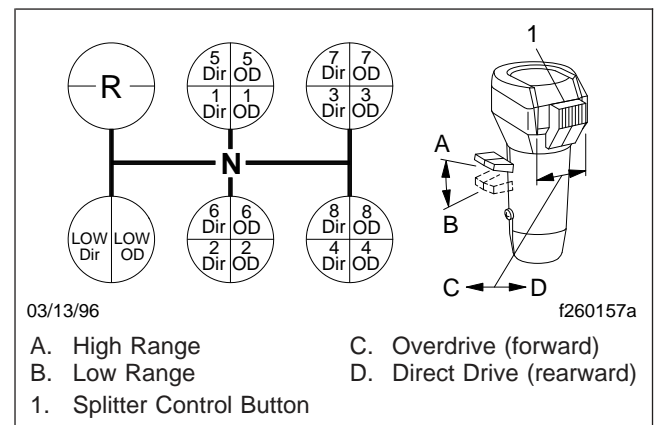

Fig. 14.2, Eaton Fuller 18-Speed Transmission Shift Pattern

3. Make sure the splitter control button is in the direct (rearward) position. See [Fig. 14.2](#).
4. For 13-speed transmissions:
Press the clutch to the floor, shift into low or 1st gear; then engage the clutch, with the engine at or near idle speed, to start the vehicle moving. Accelerate to 80 percent of engine governed speed.
For 18-speed transmissions:
Press the clutch to the floor, shift into low; then engage the clutch, with the engine at or near idle speed, to start the vehicle moving.
To shift from low direct to low overdrive, move the splitter control button into the overdrive (forward) position, then immediately release the accelerator. Press and release the clutch pedal. After releasing the clutch, accelerate again.
5. For 13-speed transmissions:
Shift upward from low to 1st gear, 2nd, etc. until 4th gear, double-clutching between shifts, and

Manual Transmissions and Hydraulic Clutch

accelerating to 80 percent of engine governed speed. See **Fig. 14.1**.

For 18-speed transmissions:

Shift upward from low overdrive to 1st direct by first moving the splitter control button into the direct (rearward) position (**Fig. 14.2**). Move the shift lever, double-clutching, to the 1st gear position.

Continue upshifting through the shift pattern.

Double-clutch during lever shifts (1st to 2nd to 3rd to 4th); single-clutch during split shifts (1st direct to 1st overdrive, etc.).

6. When in 4th gear (13-speed transmissions) or 4th overdrive (18-speed transmissions) and ready to shift up to 5th gear, use the range shift lever as follows:

For 13-speed transmissions:

While in 4th gear, pull the range shift preselection lever up, into high range. The transmission will automatically shift from low to high range as the shift lever passes through neutral. Then, disengage the clutch; double-clutch through neutral; move the shift lever to 5th gear; engage the clutch, and accelerate the engine.

For 18-speed transmissions:

While in 4th overdrive, pull the range shift preselection lever up, into high range. The transmission will automatically shift from low to high range as the shift lever passes through neutral.

Move the shift lever, double-clutching, to the 5th gear position. Just before making final clutch engagement, move the splitter control button to the direct (rearward) position; then engage the clutch and accelerate. Do not move the control button while the shift lever is in neutral.

7. Shift up through the high range gears as follows:

For 13-speed transmissions:

To shift from 5th direct to 5th overdrive, move the splitter control button (**Fig. 14.1**) into the overdrive (forward) position, then immediately release the accelerator. Press and release the clutch pedal. After releasing the clutch, accelerate again.

Continue upshifting through the shift pattern. Double-clutch during lever shifts (6th to 7th to

8th); single-clutch during split shifts (6th direct to 6th overdrive, etc.).

For 18-speed transmissions:

To shift from 5th direct to 5th overdrive, move the splitter control button (**Fig. 14.2**) into the overdrive (forward) position, then immediately release the accelerator. Press and release the clutch pedal. After releasing the clutch, accelerate again.

Continue upshifting through the shift pattern.

Double-clutch during lever shifts (6th to 7th to 8th); single-clutch during split shifts (6th direct to 6th overdrive, etc.).

Downshifting

1. Downshift from 8th overdrive to 8th direct without moving the shift lever. Flip the splitter control button to the direct (rearward) position, then immediately release the accelerator, and disengage the clutch. Engage the clutch, and accelerate the engine only after the transmission has shifted.
2. Start the downshift from 8th direct to 7th overdrive by flipping the splitter control button to the overdrive (forward) position; then, immediately double-clutch through neutral, moving the shift lever from 8th to 7th gear.
3. Shift downward through each of the high range gears, alternating the procedures in steps 1 and 2, above, until reaching 5th direct.
4. While in 5th direct and ready for the downshift to 4th (13-speed transmissions) or 4th overdrive (18-speed transmissions), push the range preselection lever down. Then, double-clutch through neutral and move the shift lever to the 4th gear position. On 18-speed transmissions, move the splitter control button to the overdrive (forward) position *before* engaging the clutch. Do not move the control button while the shift lever is in neutral.
5. Continue downshifting from 4th to 1st as follows:
For 13-speed transmissions:
Downshift through the low range gears as conditions require.
For 18-speed transmissions:

Manual Transmissions and Hydraulic Clutch

Continue downshifting from 4th overdrive to 4th direct, then 4th direct to 3rd overdrive, 3rd overdrive to 3rd direct, etc. Single-clutch when split shifting (direct to overdrive, overdrive to direct). Double-clutch when making lever shifts (4th to 3rd, 3rd to 2nd, etc.).

IMPORTANT: Never use the clutch brake when downshifting, or as a brake to slow the vehicle.

Eaton Fuller 10-Speed Range-Shift Transmissions

Refer to the Eaton website for additional information, www.roadranger.com.

General Information, Eaton Fuller Range-Shift

To operate a range-shift transmission, move the shift lever through all the low gear positions and then activate a range switch to provide an additional set of ratios in the high range. Using the same shift lever positions as in low range, move the shift lever through each position as before. On some models, the initial low gear is often used only in low range.

IMPORTANT: Not all lever positions are used in each range and the shift patterns vary between transmissions. Be sure to read the shift pattern decal on the dash for the operating instructions for the specific transmission installed in your vehicle.

10-Speed FR/FRO and RT/RTO/RTX Models

Eaton Fuller 10-speed transmissions have 10 selective, evenly spaced forward ratios. Each transmission has a 5-speed front section and a 2-speed rear range section. The 10 forward speeds are obtained by twice using a 5-speed shift pattern: the first time in low range, the second time in high range. See [Fig. 14.3](#) for the shift patterns.

NOTE: The 4th/9th and the 5th/10th shift positions in the RT (direct ratio) and RTX (overdrive ratio) transmissions are directly opposite in the RTO (overdrive ratio) transmissions

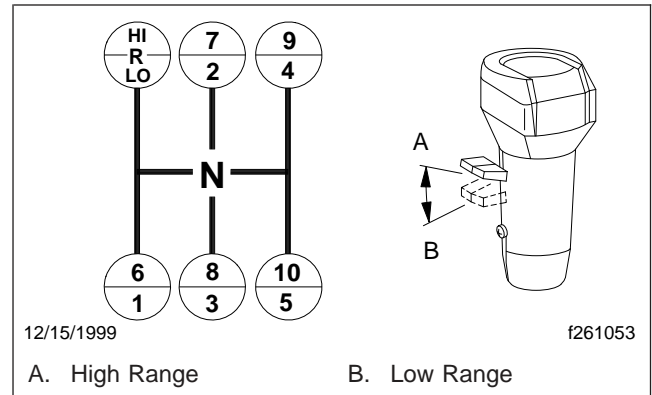

Fig. 14.3, Eaton Fuller 10-Speed Transmission Shift Patterns

Operation, Eaton Fuller Range-Shift

1. When operating off-highway, or under adverse conditions, always use low gear (if so equipped) when starting to move the vehicle.

When operating on-highway, with no load, or under ideal conditions, use 1st gear when starting to move the vehicle (except when equipped with a 9-speed RTO transmission, then always start in low gear).

For all conditions, use the highest gear that is still low enough to start the vehicle moving with engine idling, and without slipping the clutch excessively.

2. Use the clutch brake to stop gear rotation when shifting into low (or 1st) or reverse when the vehicle is stationary. The clutch brake is actuated by depressing the clutch pedal all the way to the floor.

For normal upshifts and downshifts, only a partial disengagement of the clutch is necessary to break engine torque.

3. Do not make range shifts with the vehicle moving in reverse gear.
4. Never attempt to move the range preselection lever with the gear shift lever in neutral while the vehicle is moving. Preselection with the range preselection lever must be made prior to moving the shift lever out of gear into neutral.
5. Do not shift from high range to low range at high vehicle speeds.

Manual Transmissions and Hydraulic Clutch

- Double-clutch between all upshifts and downshifts.
- After your shifting ability improves, you may want to skip some of the ratios. This may be done *only* when operating conditions permit, depending on the load, grade, and road speed.

Upshifting

- Position the gear shift lever in neutral. Start the engine, and bring the air system pressure up to 100 to 120 psi (689 to 827 kPa).
- Position the range preselection lever down, into low range.
- Press the clutch pedal to the floor; shift into low or 1st gear ([Table 14.1](#)), then engage the clutch, with the engine at or near idle speed, to start the vehicle moving. Accelerate to 80 percent of engine governed speed.

| Eaton Fuller Shift Progressions | | | |
|--|-------------|------------|------------|
| TRANS. MODEL | LOW RANGE | | HIGH RANGE |
| | Off-Highway | On-Highway | |
| 10-Speed Direct or Overdrive (RT or RTX) | | | |

Table 14.1, Eaton Fuller Range-Shift Shift Progressions

- Shift progressively upward from low or 1st gear, to the top gear in low range ([Table 14.1](#)), double-clutching between shifts, and accelerating to 80 percent of engine governed speed.
- While in the top gear of the low range shift pattern, and ready for the next upshift, flip the range preselection lever up into high range. Double-clutch through neutral, and shift into the bottom gear in high range ([Table 14.1](#)). As the shift lever passes through neutral, the transmission will automatically shift from low range to high range.
- With the transmission in high range, shift progressively upward through each of the high range gears ([Table 14.1](#)), double-clutching between shifts.

Downshifting

- With the transmission in high range, shift progressively downward to the bottom gear in high range, double-clutching between shifts.
- When in the bottom gear of the high range shift pattern, and ready for the next downshift, push the range preselection lever down into low range. Double-clutch through neutral, and shift into the top gear of the low range shift pattern. As the shift lever passes through neutral, the transmission will automatically shift from high range to low range.
- With the transmission in low range, downshift through the low range gears as conditions require.

IMPORTANT: Never use the clutch brake when downshifting, or as a brake to slow the vehicle.

Clutch

General Information

The hydraulic clutch control system consists of a pedal unit and a slave cylinder, connected by a hydraulic hose and fastened with quick-disconnect clamps. The components of the system have been specially designed to use DOT 4 brake fluid. The pedal unit includes a hydraulic subassembly, composed of the master cylinder and reservoir, which can be removed from the pedal unit for service purposes. When the clutch pedal is depressed, the fluid in the master cylinder is forced through a hydraulic line to the slave cylinder. The fluid pressure moves the slave cylinder piston, pushing the plunger rod and clutch release lever, which disengages the clutch. The hydraulic system is self-adjusting.

Clutches are designed to absorb and dissipate more heat than encountered in typical operation. The temperatures developed in typical operation will not break down the clutch friction surfaces. However, if a clutch is slipped excessively, or asked to do the job of a fluid coupling, high temperatures develop quickly and destroy the clutch. Temperatures generated between the flywheel, driven discs, and pressure plates can be high enough to cause the metal to flow and the friction facing material to char and burn.

Heat and wear are practically nonexistent when a clutch is fully engaged. But during the moment of engagement, when the clutch is picking up the load,

Manual Transmissions and Hydraulic Clutch

it generates considerable heat. An improperly adjusted or slipping clutch will rapidly generate sufficient heat to destroy itself.

To ensure long service life of the clutch; start in the right gear, be alert to clutch malfunctions, and know when to adjust the clutch.

Clutch Operation

Clutch Break-In

With a new or newly installed clutch, the clutch may slip for a short time while the friction surfaces break-in. However, allowing the clutch to slip for more than two seconds can severely damage the clutch disc, pressure plate, and the flywheel.

During initial operation of a new vehicle or a vehicle with a new clutch, check for clutch slippage during acceleration. If the clutch slips, decelerate until the clutch does not slip. Allow the clutch to cool 15 to 30 seconds, and then gradually accelerate again. If the clutch continues to slip, repeat the procedure. If necessary, repeat the procedure up to five times. If the clutch slips after five attempts, stop the vehicle. Allow the clutch to cool for at least one hour. Notify your Freightliner dealer of the problem.

CAUTION

Do not allow sustained slippage of the clutch; this could severely damage the clutch disc, pressure plate, or flywheel. Damage caused by clutch slippage due to improper break-in is not warrantable.

Moving the Vehicle in the Proper Gear

An empty truck can be started in a higher transmission gear than can a partially or fully loaded truck. A good rule of thumb for the driver to follow is to select the gear combination that allows the vehicle to start moving with an idling engine, or, if necessary, just enough throttle to prevent stalling the engine. After the clutch is fully engaged, the engine can be accelerated to the correct rpm for the upshift into the next higher gear.

Gear Shifting Techniques

Shift into the next higher gear when the vehicle speed allows the transmission input shaft speed to match the flywheel speed when engaging the clutch. This technique results in the smallest speed differ-

ence between the clutch disc and the flywheel and causes the least heat and wear on the clutch assembly. When downshifting, the input shaft speed must be increased by slightly revving the engine to match the flywheel speed for smooth clutch engagement. For transmission operating instructions, refer to the transmission headings in this manual.

Vehicle Loading

Clutches are designed for specific vehicle applications and loads. These weight limitations should not be exceeded.

CAUTION

Exceeding vehicle load limits can not only result in damage to the clutch, but can also damage the entire powertrain.

Using the Clutch

The clutch pedal must be used only to start the vehicle moving or while shifting. To start the vehicle moving, depress the clutch pedal all the way to the floor plate (see "Using the Clutch Brake") and shift from neutral to a low gear. Slowly raise your foot until the clutch starts to engage. In this position the clutch is starting to connect the transmission input shaft to the flywheel and is causing the most heat and wear. Slightly increase the engine speed and smoothly allow the clutch pedal to return to its at rest position. Do not allow the clutch to remain in the partially engaged position any longer than necessary to obtain a smooth start.

To shift gears while the vehicle is moving, push the clutch pedal most of the way (but not all of the way) to the floor plate. Shift the transmission into neutral and fully release the clutch pedal. If upshifting, wait long enough for the engine speed to decrease to the road speed. If downshifting, increase the engine speed to match the road speed. Again, push down the clutch pedal part way and then move the shift lever to the next gear position. Fully release the clutch pedal after completing the shift.

Slightly depressing the clutch pedal while driving is damaging to the clutch, because partial clutch engagement causes slippage and heat. Resting your foot on the clutch pedal will also put a constant thrust load on the release bearing, thinning the bearing lubricant and increasing the wear on the bearing.

Manual Transmissions and Hydraulic Clutch

Using the Clutch Brake

The clutch brake is applied by depressing the clutch pedal past the fully released clutch position, almost to the floor plate. The last part of the clutch pedal travel will compress the clutch brake plates together, stopping the transmission input shaft. The purpose of the clutch brake is to stop the transmission gears from rotating in order to quickly engage a transmission gear after idling in neutral.

CAUTION

Never apply the clutch brake when the vehicle is moving. If the clutch brake is applied when the vehicle is moving, the clutch brake will try to stop or decelerate the vehicle, causing rapid wear of the clutch brake friction discs. Considerable heat will be generated, causing damage to the release bearings and the transmission front bearings.

Holding the Vehicle on an Incline

Always use the vehicle service brakes to prevent the vehicle from rolling backwards while stopped on a hill. Slipping the clutch on a hill to maintain the vehicle position will quickly damage the clutch assembly.

Coasting

Coasting with the clutch pedal depressed and the transmission in a low gear can cause high driven disc speed. The clutch speed can be much higher under these conditions than when the engine is driving the clutch. This condition creates a hazardous situation due to the lack of vehicle control and due to the high clutch disc speed. Engaging the clutch under these conditions can cause component damage because of the shock loads to the clutch and drivetrain.

WARNING

Always shift into the gear that is correct for the traveling speed of the vehicle and engage the clutch. Coasting with the clutch disengaged can prevent engagement of the correct transmission gear which can cause loss of vehicle control, possibly resulting in personal injury or property damage.

High clutch disc speeds while coasting can also cause the clutch facing to be thrown off the disc. Flying debris from the clutch can cause injury to persons in the cab.

Clutch Maintenance

Clutch Adjustment

Eaton Fuller Solo clutches are adjustment-free. As the clutch wears, its wear-adjusting technology monitors clutch components and makes any necessary adjustments. The wear adjusting technology comes from two sliding cams, which rotate to maintain the proper adjustment. Atop the upper cam, a wear indicating tab mirrors the cam's movement, letting you know when it's time to replace the clutch.

CAUTION

Operating the vehicle with incorrect free pedal could result in clutch damage.

Hydraulic Clutch Fluid Reservoir Checking

Make sure that the clutch fluid reservoir is full. See [Fig. 14.4](#). The reservoir is full when the fluid level is up to the "max" mark. The fluid level must always be above the "min" mark. Use only heavy-duty brake fluid, DOT 4, in the clutch hydraulic system.

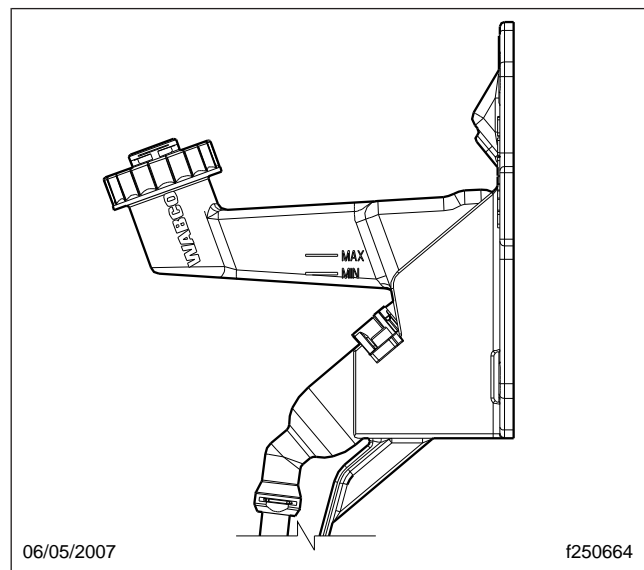

Fig. 14.4, Clutch Fluid Reservoir

15

Automated Transmissions

| | |
|--|-------|
| Detroit™ Automated Transmissions | 15.1 |
| Freightliner SmartShift Shift Control | 15.5 |
| Eaton Fuller UltraShift | 15.6 |
| Eaton Fuller AutoShift Automated Transmissions | 15.11 |
| Eaton Fuller UltraShift PLUS | 15.14 |

Automated Transmissions

Detroit™ Automated Transmissions

Detroit transmissions have twelve forward gears and up to four reverse gears that can be shifted automatically or manually. Shifting and clutch actuation are computer controlled, and there is no clutch pedal needed to operate the vehicle. Automatic shifts are selected for fuel economy or engine power. Manual shifts can be requested with the shift control and the transmission ECU grants them when conditions permit. In all cases, shifts depend on the following factors: engine speed, accelerator pedal position, service brake usage, engine brake operation, vehicle load status, and road conditions.

NOTE: To avoid potential engine stall risk or unexpected shifting, use the interaxle differential lock when the vehicle is operated in slippery conditions. See [Chapter 16](#) for information about the interaxle differential lock.

Detroit™ Multifunction Control

Vehicles with Detroit transmissions use the control shown in [Fig. 15.1](#). This control can be used to request manual shifts, change driving mode, and set engine brake levels. See [Table 15.1](#) for an overview of control functionality.

D/N/R Switch

Use the "D/N/R Switch" to request drive (D), neutral (N), or reverse (R).

Mode Switch

The driving mode can be changed using the Mode switch on the shift control (see [Fig. 15.1](#)). To activate the manual drive mode, press and hold the switch briefly. Press the switch quickly to activate the automatic drive mode or change between Automatic Economy and Automatic Performance modes.

Upshifting and Downshifting

Gear shifts can be requested manually; push the lever away to request a downshift, or pull the lever toward you to request an upshift. See [Table 15.1](#) for more information about upshift and downshift requests.

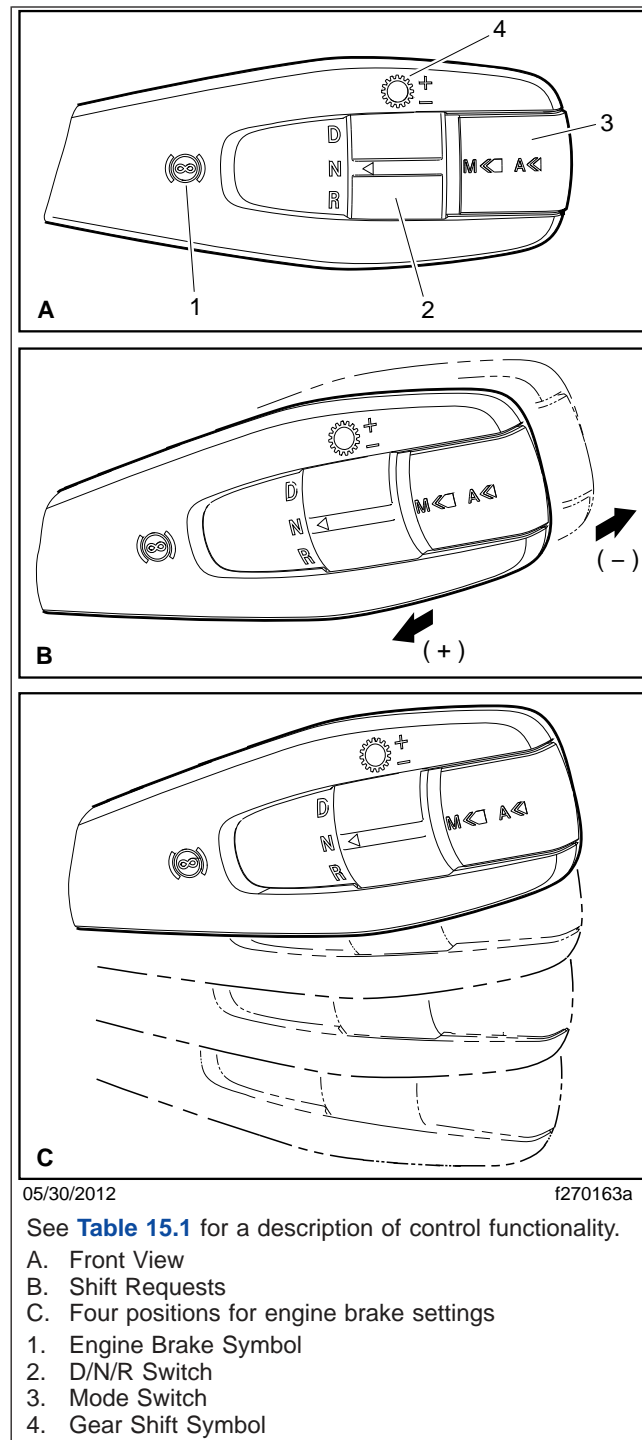

Fig. 15.1, Detroit Multifunction Control

Automated Transmissions

| Functionality, Detroit Multifunction Control | | |
|--|--|---|
| Function/Switch | Action/Position | Request |
| D/N/R | D | Forward gears |
| | N | Neutral |
| | R | Reverse gears |
| Mode | Depress switch and release it quickly | Activate the automatic drive mode, or switch between Automatic Economy and Automatic Performance. |
| | Depress switch and hold it briefly | Activate the manual drive mode. |
| Upshifting and Downshifting | Pull the lever toward you momentarily | Upshift, single gear |
| | Pull the lever toward you in quick repetitions | Upshift, multiple gears |
| | Push the lever away momentarily | Downshift, single gear |
| | Push the lever away in quick repetitions | Downshift, multiple gears |
| Engine Brake* | Lever at position 0 (top) | Engine brake off |
| | Lever at position 1 | Low intensity |
| | Lever at position 2 | Medium intensity |
| | Lever at position 3 (bottom) | High intensity |

* For functions with cruise control active, see [Chapter 5](#).

Table 15.1, Functionality, Detroit Multifunction Control

Engine Brake

The engine brake is controlled by the lever position (as shown in [Fig. 15.1](#), Ref. C). At the top position, the engine brake is off, and at the three lower positions, the engine brake is on and the intensity (low, medium, high) increases with each step down. For more information about using the engine brake, see [Chapter 13](#).

NOTE: Using the engine brake with cruise control can be used to activate Descent Control Mode or Deceleration Mode. For more information, see "Cruise Control" in [Chapter 5](#).

Power Up and Shift into Gear

1. With the parking brake set and Neutral (N) selected on the shift control, turn the ignition switch to the ON position.
2. Start the engine.
3. Apply the service brake.
4. Select the desired starting gear.
5. Release the parking brake.
6. Release the service brake and apply the accelerator.

Gear Display Window

The gear display window shows the current transmission gear and driving mode. See [Fig. 15.2](#).

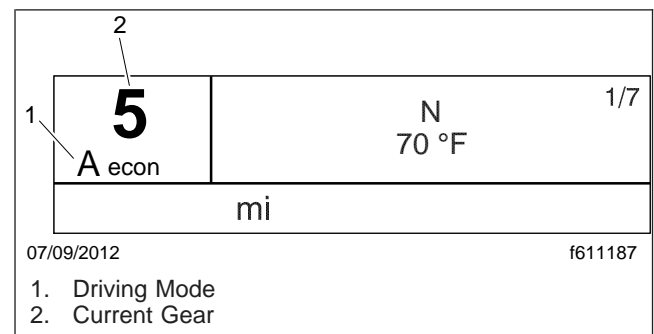

Fig. 15.2, Gear Display Window

Driving Modes

There are three driving modes: Manual, Automatic Economy, and Automatic Performance.

In Automatic Economy mode, gear shifts are designed for saving fuel. In Automatic Performance mode, gear shifts are designed for higher performance and are made at higher engine speeds. In manual mode, gear shifts are requested manually. See [Chapter 5](#) for more information about upshifting and downshifting using the control.

Automated Transmissions

NOTE: In Automatic Performance mode, the transmission will automatically change to Automatic Economy mode if it hasn't received a request for more power in several minutes, unless current road conditions require higher engine performance.

Selected Gear

If the selected gear is different than the current gear for longer than a half second, the current gear display will flash and the selected gear value will be shown. Once the current gear and selected gear match, the selected gear display disappears and the current gear display stops flashing. See [Fig. 15.3](#).

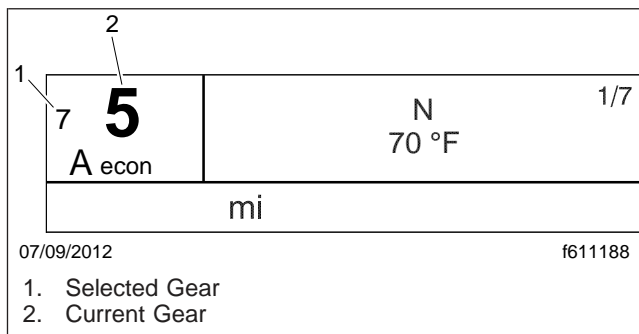

Fig. 15.3, Selected Gear Display

Suggested Shift

In Manual mode only, a suggested shift is displayed to indicate the most economical gear available. The suggested shift is the number of up or down arrows from the current gear with a maximum of three up or down arrows. See [Fig. 15.4](#).

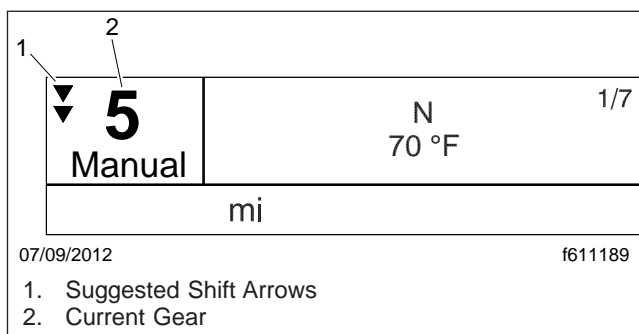

Fig. 15.4, Suggested Shift

eCoast

The eCoast feature can improve driving economy. When conditions permit, the transmission control automatically shifts the transmission to neutral to coast at speeds of approximately 22 mph (35 km/h) and above. An "E" shows in the gear display window when eCoast is in effect. See [Fig. 15.5](#).

The eCoast function is not active when any of the following occur:

- the accelerator pedal is pressed.
- vehicle acceleration rate is exceeded.
- the service brake pedal is pressed.
- the engine brake is in use.
- cruise control brakes or accelerates.
- vehicle speed exceeds the cruise control set speed by more than approximately 4 mph (6 km/h).
- the speed limiter is active and the maximum speed set is exceeded.
- diesel particulate filter (DPF) regeneration occurs.

The eCoast function cannot be deactivated when the Automatic Economy mode is active.

NOTE: To disable eCoast, see an authorized Freightliner service facility.

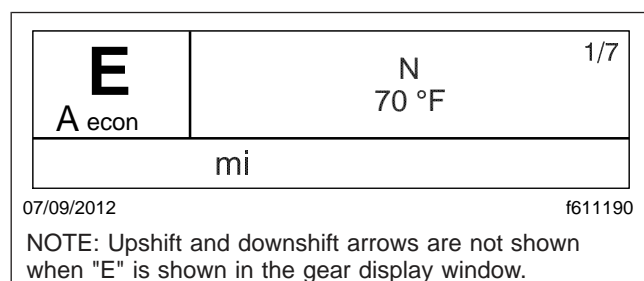

Fig. 15.5, eCoast Display

Creep Mode

Creep mode allows the vehicle to be maneuvered at very slow speeds. To activate Creep mode for the first time within the current driving cycle, press the accelerator pedal to launch the vehicle, thereby fully

Automated Transmissions

engaging the clutch. Following this and for the duration of the current driving cycle, Creep mode is active.

Once the vehicle is stopped via the service brakes, the vehicle will begin to creep again, without the accelerator pedal actuation, as soon as the service brakes are released.

To begin using Creep mode (once active) from a parked position, shift from neutral to either drive or reverse, release the service brakes, and briefly depress the accelerator pedal. The vehicle's urge to move can then be felt.

If creep is active and no acceleration is achieved within five seconds, then Creep mode will abort. A display message notifies the operator when Creep mode is about to be aborted.

IMPORTANT: When slowing down from higher speeds in drive or reverse, remember that Creep mode will be in effect at lower speeds. Use the service brakes to stop the vehicle.

Clutch Abuse Protection

A vehicle equipped with a Detroit transmission does not have a clutch pedal, but still has a clutch that is operated automatically and can be damaged by abusive driver actions. To protect the clutch, the vehicle has a clutch abuse protection system that alerts the driver and restricts functionality when needed. Extended periods in Creep Mode, slipping the clutch (using the accelerator pedal to hold the vehicle on a hill, for example), and high clutch temperatures can activate the clutch abuse protection system. A display message notifies the operator when the protections are needed.

NOTICE

To hold the vehicle stationary on an uphill slope, use the service brakes, not the accelerator pedal. Using the accelerator pedal can overheat and damage the clutch. To start moving, use the accelerator pedal and release the brakes as the vehicle begins to move.

There are three clutch abuse protection levels. At each, the driver is alerted and functionality is modified; see [Table 15.2](#).

To avoid clutch overheating, follow these tips:

- To hold the vehicle stationary on an uphill slope, use the service brakes, not the accelerator pedal.
- To start moving on an uphill slope, use the accelerator pedal and release the brakes as the vehicle begins to move.
- When hooking up to a trailer, ensure the trailer is high enough to back under, and use first gear reverse.
- Avoid starting in higher gears, and start in first gear when a trailer is attached.
- Ensure trailer brakes have had time to completely release prior to starting.
- Do not use Creep mode for an extended period. Stop or adjust the vehicle speed when warned to deactivate Creep mode.

Engine Overspeed Alerts

To help protect the engine, the system has display messages to notify the operator when the engine has exceeded certain thresholds and needs to be slowed down before significant engine damage occurs. There are two warnings, one at about 2400 rpm and another at 2500 rpm, indicated with messages and a fault code.

Low Transmission Air Warning

Pneumatic controls are used to shift the transmission. If there is inadequate air pressure, a warning is displayed and the quality of gear shifts may be degraded. Wait for air pressure to build before operating the vehicle.

IMPORTANT: If the low transmission air warning indicator appears while the vehicle is in operation, safely pull the vehicle off the road, and correct the problem.

| Clutch Abuse Alerts and Protections | | | | |
|-------------------------------------|---------------------------|--------------------|----------------|-----------------|
| Alert Level | Alert | Protections | | |
| | | Highest Start Gear | Creep Mode | Clutch Function |
| 1 | Heavy clutch load message | 1 | No restriction | Normal function |

Automated Transmissions

| Clutch Abuse Alerts and Protections | | | | |
|-------------------------------------|------------------------------------|--------------------|------------|--|
| Alert Level | Alert | Protections | | |
| | | Highest Start Gear | Creep Mode | Clutch Function |
| 2 | Heavy clutch load message | 1 | Disabled | Normal function |
| 3 | Clutch overload message and buzzer | 1 | Disabled | If the accelerator pedal is depressed, the clutch closes at fixed rate. If the accelerator pedal is released, the clutch opens at fixed rate. |

Table 15.2, Clutch Abuse Alerts and Protections

Freightliner SmartShift Shift Control

General Information, SmartShift

The SmartShift transmission control is an electronic transmission control device. It is installed with the following transmissions:

- Eaton Fuller UltraShift™
- Eaton Fuller UltraShift™ PLUS
- Eaton Fuller AutoShift™

It replaces the typical floor-mounted shift lever or dash-mounted push button control.

SmartShift accepts driver requests for transmission functions and transmits them through hard wiring to the transmission control unit (TCU). SmartShift is a true shift-by-wire system.

SmartShift offers two main advantages over conventional transmission control devices. Without a floor-mounted shift control, usable cab space is increased. The SmartShift control mounts to the right-hand side of the steering column and is operated by the fingers of the driver's right hand, allowing both hands to remain on the steering wheel.

A two-position slide switch (Fig. 15.6) is mounted on the body of the control lever just before the paddle widens out. The slide switch allows the driver to choose automatic (AUTO) or manual (MAN) mode.

In AUTO mode, gears shift automatically, without driver interaction. Manual gearshifts are accomplished by a momentary pull or push on the control in the plane perpendicular to the steering wheel. Pull upward (toward you) on the control to upshift and push downward (away from you) to downshift. The

control is spring-loaded and returns to mid-position when released after an upshift or downshift.

For Eaton Fuller UltraShift, UltraShift PLUS, and AutoShift transmissions (Fig. 15.6), a four-position (R, N, D, L) selector switch is located at the end of the lever.

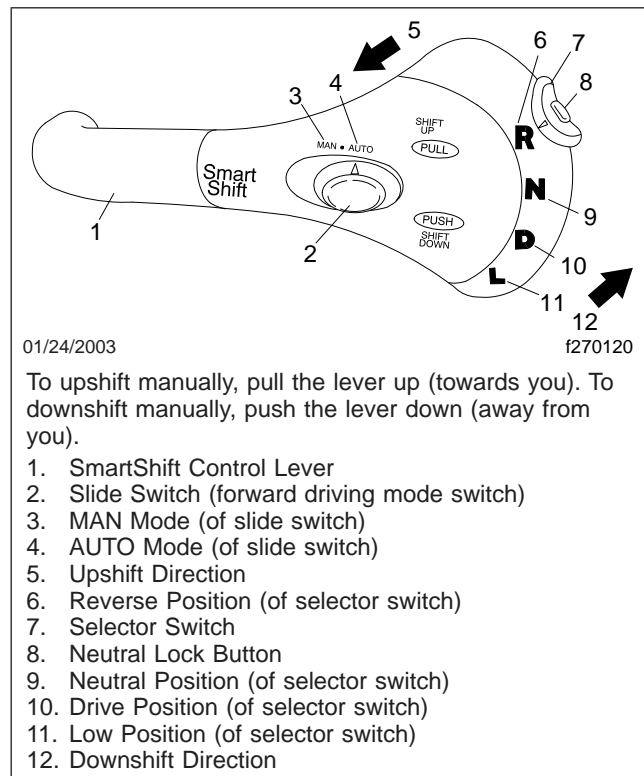

Fig. 15.6, SmartShift Control (Eaton Fuller UltraShift, UltraShift PLUS, and AutoShift Transmissions)

Embedded in the selector switch is a small neutral lock button to prevent accidental shifts into gear from neutral. Any time you shift through N, press down on the neutral lock button to move the switch from neutral (N) to another gear, such as drive (D), low (L), or reverse (R). When shifting to N, it is not necessary to press the neutral lock button.

Eaton Fuller UltraShift

General Information, UltraShift DM

Eaton® Fuller® UltraShift™ DM is a ten-speed heavy-duty fully automated transmission. No clutch pedal is required to operate the vehicle.

UltraShift DM uses a dry clutch system which is offered only on this automated transmission system.

The UltraShift transmission uses the four-position SmartShift lever on the steering column to select gears. To know what gear the transmission is in, look at the round current gear indicator on the right-hand control panel as shown in Fig. 15.7. All forward shifts can be made either manually or automatically, at the driver's choice.

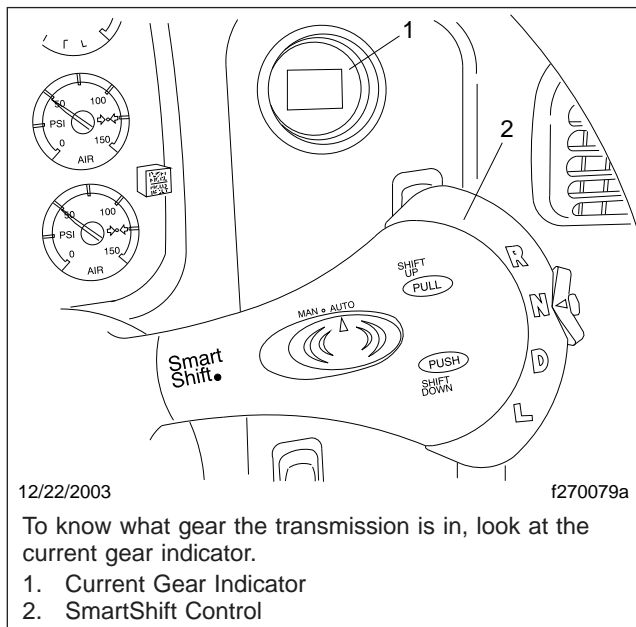

Fig. 15.7, Shift Controls and Indicators, UltraShift Transmissions

Operation, UltraShift DM

Power Up

1. With the parking brake set, select neutral (N) by moving the selector switch to the N position.
2. With the transmission in neutral, turn on the ignition switch. The CHECK TRANS and TRANS TEMP telltale lights come on and go out again (bulb check).
3. After the ignition is turned on, the current gear indicator shows the dot display, arranged in a square pattern. All dots in the pattern should light up, without gaps or spaces. See Fig. 15.8.

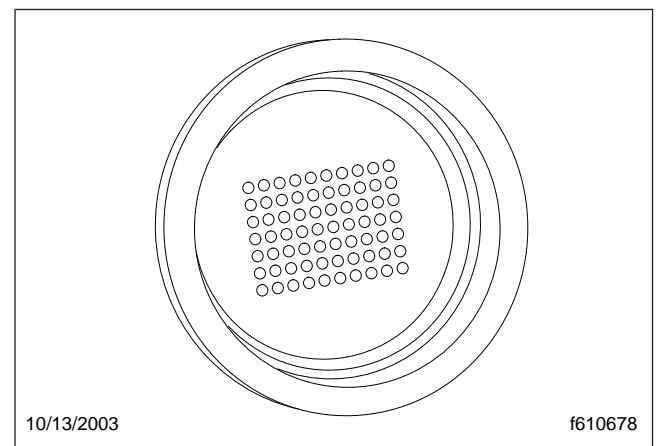

Fig. 15.8, Power-Up Dot Display

4. Wait for the current gear indicator to show a solid N. When the N is solid, rather than flashing, the UltraShift DM TCU is powered up. Apply the service brake and start the engine.
5. Select drive (D) by pressing in the neutral lock button and moving the selector switch downward to the position below neutral. Release the parking brake. The gear is displayed on the current gear indicator.

NOTE: When D is selected, the transmission controller starts up in second gear. If desired, the driver can select to start up in first. No other start gear is available.

6. On a level grade, release the service brake and press down on the throttle pedal to allow the vehicle to move forward. The vehicle will not move until the pedal is depressed.

Automated Transmissions

WARNING

When starting or stopping on hills and grades, use extra care to prevent the vehicle from rolling back. A rollback accident could cause death, serious personal injury, or property damage.

7. Prevent the vehicle from rolling backwards when stopped on a hill or grade, or when the vehicle is starting from a stop on a hill or grade.

7.1 To start from a full stop on a hill or grade, quickly move your foot from the brake pedal and press firmly on the throttle pedal.

On steep hills, set the parking brake, and release it only when there is enough engine power to prevent rollback.

7.2 To stop on a hill or grade, press and hold the brake pedal to keep the vehicle from moving.

On steep hills, set the parking brake. When parking, chock the tires, front and/or rear. Never hold a hill with the throttle pedal. This will cause the clutch to over-heat.

Power Down

1. Apply the service brakes.
2. Select neutral (N) by pressing in the neutral lock button and moving the selector switch to N. When the N on the current gear indicator is solid, rather than flashing, the UltraShift DM TCU is ready to power down.
3. With the transmission in neutral, set the parking brake.
4. Turn off the ignition key and shut down the engine.

Automatic and Manual Modes

The SmartShift control has a slide switch located on the body of the control lever just before the paddle widens out. See [Fig. 15.9](#). The slide switch controls the forward driving mode, automatic or manual.

To change mode at any time, move the slide switch in the desired direction. This allows the driver to respond to a wide range of driving conditions, such as blind corners, tight curves, and steep hills.

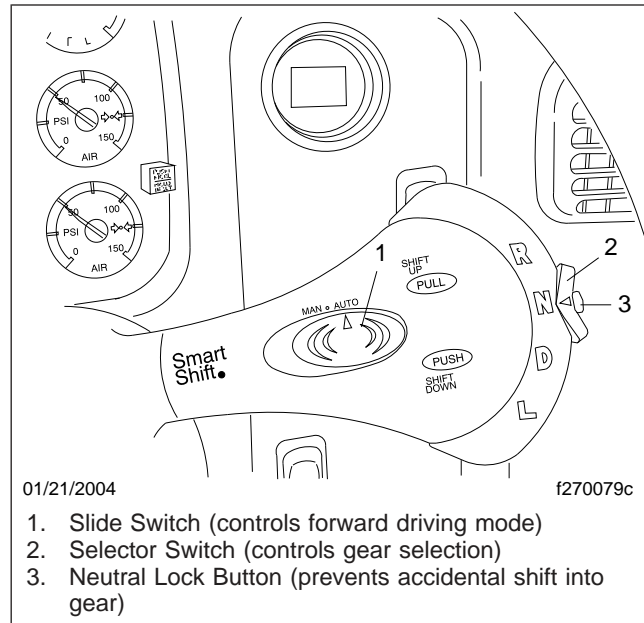

Fig. 15.9, Switches, UltraShift Transmissions

IMPORTANT: Whatever the mode, it is always possible to shift manually by moving the lever up or down as needed. When the engine speed is within 75 revolutions per minute (rpm) of the load-based shift point for an automatic shift, the UltraShift DM TCU will advance the shift.

In either mode, the gear indicator displays the current gear. See [Fig. 15.10](#).

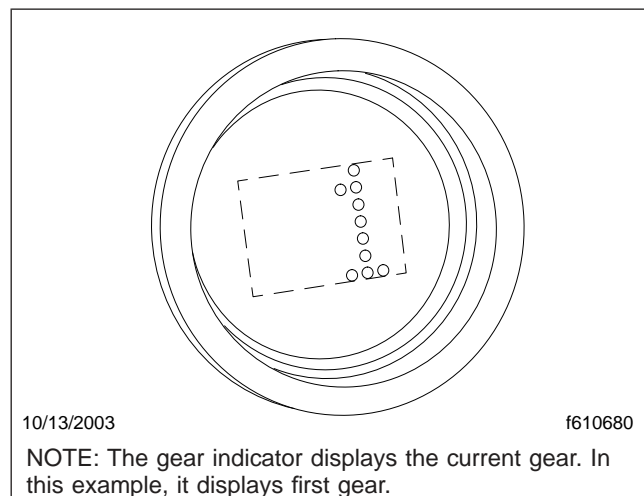

Fig. 15.10, Current Gear Display

At the start of a shift, the current gear continues to display until the transmission has been pulled into neutral. At this point, as the transmission is synchronizing for the new (target) gear, the gear indicator flashes the number of the new gear.

When the shift is complete, the new gear displays solid, without flashing.

Automatic Mode (AUTO)

In automatic drive mode (AUTO), upshifts and downshifts are made by the transmission without driver intervention. Press in the neutral lock button, move the selector switch to drive (D), and press down on the throttle pedal. The transmission will shift automatically.

If driving conditions require, it is still possible to request a manual shift. The transmission will make the shift if the engine speed is within 75 rpm of the load-based shift point for that gear.

If the driver presses down on the throttle pedal after a manual downshift in automatic mode, the transmission will upshift again if the UltraShift DM TCU requires it.

Manual Mode (MAN)

In manual drive mode (MAN), upshifts and downshifts are made by the driver:

- To shift up, pull the lever up (towards you).
- To shift down, push the lever down (away from you).

The system will hold the current gear until the driver requests a shift. In downhill situations in particular, the driver must be alert to vehicle speed by downshifting and/or using the service brakes as needed.

A shift request will still be refused if the selected gear would cause engine overspeed or excessive lugging.

Selecting Gears

Reverse

Reverse (R) is at the upper end of the four-position selector switch located at the end of the SmartShift control lever. To select R, press in the neutral lock button and move the selector switch upward to the position above neutral.

UltraShift DM has two reverse gears, reverse low and reverse high. To shift manually between them,

use the shift lever as described for MAN mode. There is no AUTO mode for reverse.

When reverse low is selected, the letter R displays on the current gear indicator. When reverse high is selected, the letter H displays on the current gear indicator. See [Fig. 15.11](#).

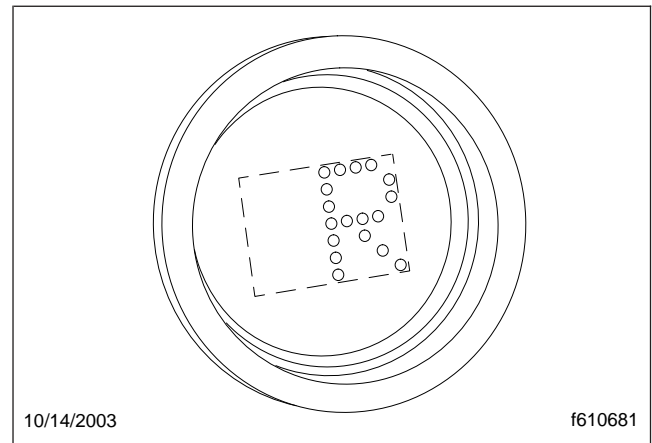

Fig. 15.11, Reverse Gear Display

IMPORTANT: Under normal conditions, do not select reverse with the vehicle moving forward.

The vehicle must be moving at less than two miles per hour (3 km/h) before selecting reverse. If reverse is selected when the vehicle is moving faster, an audible alert will sound and continue sounding at three-second intervals until the control lever is returned to the D position or the vehicle slows to the proper speed.

If necessary to rock the vehicle, use the selector switch to shift back and forth at low speed between reverse and drive.

Neutral

IMPORTANT: Always start the engine with the transmission in neutral, the parking brake set, and the service brakes applied.

Neutral (N) is directly below R on the four-position selector switch located at the end of the SmartShift control lever. To select N, press in the neutral lock button and move the selector switch to the position below R. When neutral is selected, the letter N displays on the current gear indicator. See [Fig. 15.12](#).

Automated Transmissions

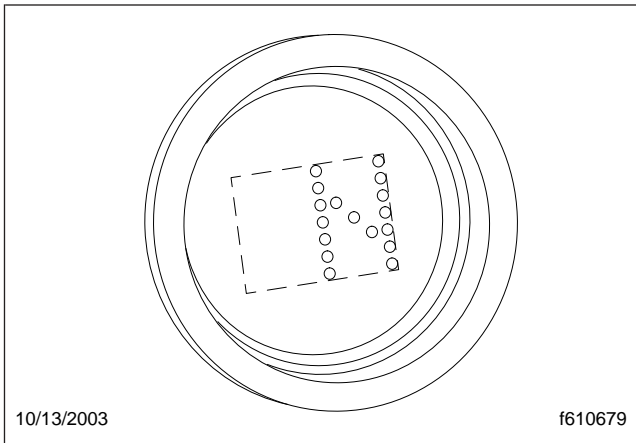

Fig. 15.12, Neutral Display

WARNING

Do not coast in neutral. Coasting in neutral can cause an accident, possibly resulting in severe personal injury or death.

Neutral is always available during operation, whatever the vehicle speed. When in neutral, requests to upshift or downshift are ignored. If the selector switch is moved from neutral to drive while the vehicle is moving, the transmission will shift into a gear within the engine's operating speed range.

When shifting from neutral, always press on the brake pedal. If the brake pedal is not pressed, the transmission will not shift, the current gear display will flash N, and an audible alert will sound.

NOTE: To reset the transmission, return the selector switch on the SmartShift lever to N and attempt the shift again, this time with the brake pedal pressed.

Before shutting down the engine, return the selector switch to N. When the ignition is turned off, the transmission will reset to neutral in a few minutes regardless of the position of the shift lever.

Drive

Drive (D) is directly below N on the four-position selector switch located at the end of the SmartShift control lever. To select D, press in the neutral lock button and move the selector switch to the position below N. When drive is selected, the number of the

currently selected forward gear (1 through 10) displays on the gear indicator. See [Fig. 15.10](#).

When in drive, requests to upshift or downshift are enabled. Either manual or automatic mode can be selected on the slide switch.

Two starting gears are available, first and second. The default starting gear is second, but first can be selected by the driver, if desired. To change the starting gear, press the brake pedal and select D with the vehicle stopped. The current gear indicator will display the starting gear. Move the shift lever up or down until the desired starting gear is displayed.

The UltraShift DM TCU adapts to the working conditions of each vehicle and its driver. After power up or a load change, it needs to learn the new conditions. While learning, it may hold a gear too long before upshifting. Start the upshift manually. It may take three or four shifts before UltraShift succeeds in learning the new load-based shift points, but after that it will handle the shifting automatically.

Low

Low (L) is at the lower end of the four-position selector switch located at the end of the SmartShift control lever. To select L, press in the neutral lock button and move the selector switch to the position below D.

When in low, the current gear is maintained. Requests to upshift are not enabled.

IMPORTANT: If the engine is approaching overspeed, the UltraShift DM TCU will override the current gear setting and upshift to prevent engine damage.

To enhance engine braking, downshifts are performed at higher rpm than normal.

If L is selected from neutral while stopped, the vehicle starts up in first gear and stays there until the engine approaches overspeed.

Upshifting

To request an upshift with the transmission in drive, pull the control lever up (towards you). If the gear is available, the transmission upshifts and the new gear displays on the gear indicator. No skip shifts are available while upshifting.

No upshifts are available in low, except to prevent engine overspeed.

If the transmission does not upshift quickly enough after power-up or a load change, begin the shift manually. The UltraShift DM TCU will learn the new load-based shift conditions after three or four shifts.

If the gear requested is unavailable, a tone will sound. An unavailable request to upshift is not stored in memory. The upshift must be requested again.

Downshifting

NOTE: The driver can manually downshift at any time, even when the slide switch is set to AUTO mode.

To request a downshift with the transmission in drive or low, push the control lever down (away from you). If the gear is available, the transmission downshifts and the new gear displays on the gear indicator. Skip shifts are available while downshifting.

For best engine braking, select low while moving. In low, downshifts are performed at higher rpm than in drive.

IMPORTANT: If the engine is approaching overspeed, the UltraShift DM TCU will override the current gear setting and upshift to prevent engine damage.

If the gear requested is unavailable, a tone will sound. An unavailable request to downshift is not stored in memory. The downshift must be requested again.

When coasting to a stop, the UltraShift DM TCU may not finish the downshift until the driver presses down on the throttle pedal again.

IMPORTANT: A downshift request can never result in a shift into neutral, even if the vehicle is in the drive position in the lowest possible gear.

Before starting down a hill, slow down. Downshift to a speed that you can control without hard pressure on the service brakes.

Before entering a curve, slow down to a safe speed. Downshift if necessary. This lets you use some power through the curve to help the vehicle be more stable on the turn. It also allows you to regain speed faster as you come out of the curve.

Ultrashift Diagnostics

Clutch Protection Fault

Excessive clutch slippage creates heat and reduces the life of the clutch. These are some conditions which lead to clutch abuse:

- Using the throttle to hold the vehicle on a grade
- Starting the vehicle in too high a gear
- Overloading the vehicle
- Using high idle with the vehicle in gear

The UltraShift DM TCU is programmed to prevent clutch abuse. When the clutch overheats, the following alerts take place:

- The TRANS TEMP light comes on
- The current gear indicator displays CA
- A warning tone sounds at one-second intervals

The alerts continue until the clutch cools, the throttle is released, or the clutch is fully engaged.

System Problem

In the event of a problem, do the following steps.

1. Note the driving conditions at the time the problem occurred.
2. Record the status of the transmission at the time of the problem (AUTO or MAN mode, gear setting R, N, D, or L, current gear, engine speed, etc.)
3. Reset the system, using the procedure below.

Reset Procedure

Transmission operation can sometimes be restored by doing the following reset procedure:

1. Stop the vehicle when it is safe to do so. Set the parking brake.
2. Place the selector switch in neutral and turn off the ignition.
3. Check all harness connectors as described in [Chapter 21](#).
4. Wait at least two minutes with the engine shut down.
5. Restart the engine.

Automated Transmissions

If the problem continues, contact an authorized Freightliner or Eaton service facility.

Locked In Gear

If the transmission becomes locked in gear, a dash (–) will appear on the current gear indicator when the vehicle is restarted during the reset procedure.

NOTE: If the transmission becomes locked in gear while the vehicle is moving, increased braking effort may be required to stop the vehicle.

If the current gear indicator displays a dash during power-up with the selector switch in neutral, do the following steps.

1. Make sure the parking brake is set.
2. Turn off the ignition and wait at least two minutes.
3. Apply the service brakes.
4. With the service brakes applied, release the parking brake.
5. Make sure the selector switch is in neutral and turn on the ignition key. Do not attempt to start the engine at this time.
6. If necessary to get the transmission to shift into neutral, release the pressure on the brake pedal slightly.
7. Once the UltraShift DM TCU reaches neutral, a solid N will appear on the current gear indicator and the vehicle will start. Make sure the service brakes are applied and the parking brake is set.

If the current gear indicator continues to display a dash, contact an authorized Freightliner or Eaton service facility.

Eaton Fuller AutoShift Automated Transmissions

Refer to the Eaton website for additional information, www.roadranger.com.

General Information, AutoShift 10-Speed RT/RTO Models

Eaton Fuller 10-speed AutoShift transmissions have 10 forward speeds and two reverse speeds. The

transmission consists of a 5-speed front section and a 2-speed rear section. The driver must use the clutch to start and stop the vehicle.

The driver does not need to break torque or increase or decrease engine speed to synchronize the shift. The transmission signals the engine controller when to break torque and the engine controller automatically increases or decreases engine speed. When engine speed is correct, the transmission engages the next gear and signals the engine controller to resume operation.

WARNING

When starting or stopping on hills and grades, use extra care to prevent the vehicle from rolling back. A rollback accident could cause death, serious personal injury, or property damage.

The AutoShift system consists of the following components:

- The SmartShift control paddle on the steering column. See [Fig. 15.6](#).
- The gear display module ([Fig. 15.13](#)) mounted on the dashboard indicates the current gear position or transmission status. The display also flashes the next gear to be engaged while the transmission is in neutral during a gear change.
- The shifter mechanism performs shifts at the front portion of the transmission. It preselects the shift to neutral and completes the gear change after driver input.
- The Electronic Control Unit (ECU) includes two controllers: a transmission ECU and a system ECU. The transmission ECU controls all transmission shift functions and the system ECU manages all vehicle interfaces for transmission shift functions.
- An electronic range valve, controlled by the transmission ECU, is used to perform range shifts.

Operation, AutoShift with SmartShift Automatic and Manual Modes

A two-position slide switch (forward driving mode switch) is located near the end of the control ([Fig. 15.6](#)). The switch positions are labelled MAN

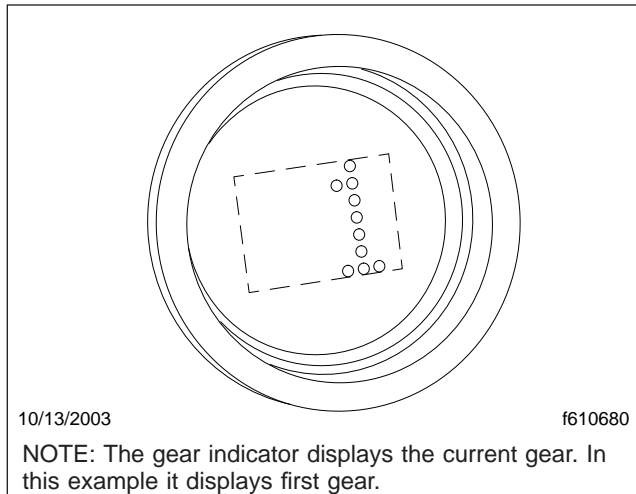

Fig. 15.13, Gear Display Module

(manual shift mode) and AUTO (automatic drive mode).

NOTE: In automatic drive mode, upshifts and downshifts require no driver interaction. Move the selector switch to the drive (D) position, disengage the clutch to engage the gear selected, engage the clutch and drive the vehicle. In manual shift mode, upshifts and downshifts require either a pull upward or push downward on the control.

Driver Message Center

Gear information is presented to the driver on the dash display. In automatic drive mode, the number of the forward gear currently engaged appears continually on the message display screen when in drive (D). In manual shift mode, the current gear is displayed until a new gear is requested. When neutral (N) is engaged, "N" will appear on the message display screen. When reverse (R) is engaged, either "RL" or "RH" will appear on the message display screen.

IMPORTANT: The information shown on the message display screen indicates the state of the transmission only, not the state of the SmartShift control.

Neutral Position

Select neutral by sliding the selector switch to the "N" position.

NOTE: Neutral is always available during operation. When in neutral, upshift and downshift requests are ignored. If the mode selector switch is moved from neutral (N) to drive (D) while the vehicle is moving, the transmission will shift into a gear causing the engine to go to a high torque level, under the engine's rated torque.

WARNING

Do not coast in neutral. Coasting in neutral can cause an accident, possibly resulting in severe personal injury or death.

Selecting a Starting Gear

1. In automatic mode, select drive (D) by sliding the selector switch downward to the next position below the neutral position.
2. Disengage the clutch to engage the gear selected. Engage the clutch and drive the vehicle.

Changing the Default Starting Gear

To select a starting gear other than the default starting gear, follow the instructions below.

1. Make sure the vehicle is stopped and in drive.
2. In either automatic or manual mode, pull upward on the control (to increase), or push downward (to decrease). Each pull upward on the control increases the starting gear by one gear, but no higher than fourth gear.
3. The number of the gear selected will flash on the message display screen until the driver engages the clutch. This gear will be stored in memory as the default starting gear until either a different starting gear is selected by the driver or the engine is shut down.

NOTE: The transmission may also be programmed so that it is not possible to select a starting gear other than the preprogrammed default starting gear.

Upshifting

NOTE: With the transmission in drive (D) in the automatic mode, upshifts require no driver interaction.

Automated Transmissions

1. With the transmission in drive in the manual mode, request an upshift by pulling upward on the control. If the requested gear is available, the transmission will upshift.

NOTE: A single, momentary pull upward on the control selects the next higher gear when it is available. Two consecutive, momentary upward pulls will cause a skip shift when the next two higher gears are available and conditions are right.

2. To skip shift, move the control two times in less than 1/2 second. The number of the gear engaged will appear on the message display screen.

NOTE: The Eaton Fuller AutoShift 18-speed transmission is able to perform triple upshifts when the next three higher gears are available and conditions are right. To triple-shift this transmission, move the control three times in less than 1/2 second.

If a requested gear is not available, an audible warning will sound and the gear display module will indicate that the gear is not available. An unavailable requested upshift is not stored in memory. The upshift must be requested again.

Downshifting

NOTE: With the transmission in drive (D) in the automatic mode, downshifts require no driver interaction.

1. With the transmission in drive in the manual mode, request a downshift by pushing downward on the control. If the requested gear is available, the transmission will downshift.

NOTE: A single, momentary push downward on the control selects the next lower gear when it is available. Two consecutive, momentary downward pushes will cause a skip shift, when the next two lower gears are available and conditions are right.

2. To skip shift, move the control two times in less than 1/2 second. The number of the gear engaged will appear on the message display screen.

NOTE: The Eaton Fuller AutoShift 18-speed transmission is able to perform triple downshifts when the next three lower gears are available and conditions are right. To triple shift this transmission, move the control three times in less than 1/2 second.

If a requested gear is not available, an audible warning will sound and the gear display module will indicate that the requested gear is not available. Unlike upshifting, an unavailable requested downshift is stored in memory and the shift will be made when the gear is available. The time limit for this memory is a programmable parameter.

Start-Up

1. With the parking brake applied, press the clutch all the way down to the floor.
 2. Start the engine.
 3. Check to make sure the transmission is in neutral.
 4. With the transmission in neutral, release the clutch.
- NOTE: This allows the speed sensor on the input shaft to get a reading.
5. Press down on the clutch again and release the parking brake.
 6. Select the desired starting gear.
 7. Release the clutch.

Reverse

1. To engage reverse (R), slide the selector switch upward to the next position above the neutral position and disengage the clutch.

NOTE: AutoShift 10- and 18-speed transmissions have a dual-range reverse. Reverse low (RL) is the default reverse gear.

2. Select reverse high (RH) by pulling upward on the control.

NOTE: Reverse may be engaged below a programmable forward speed in order to rock the vehicle. If reverse is selected above the programmed forward speed, an audible warning will

sound and a message indicating that the gear is not available will appear on the message display screen.

Low Gear Operation

Use low (L) when descending steep hills and using compression braking. Engine speed will be increased by 200 rpm and shift points will be offset by 200 rpm. The efficiency of the exhaust brake will be maximized.

Using the Clutch

Use the clutch to start and stop the vehicle.

Eaton Fuller UltraShift PLUS

Eaton Fuller UltraShift PLUS automated transmissions use shift selection software and electric clutch actuation; a clutch pedal is not needed to operate the vehicle. These transmissions use the four-position SmartShift control (see [Fig. 15.6](#)) on the steering column to select mode, direction, neutral, low, and to make manual shifts. To know what gear the transmission is in, see the current gear indicator on the dash. Forward shifts can be made either manually or automatically.

Power Up

NOTE: Engine cranking is delayed until the transmission power-up is complete and the gear display shows a solid "N".

1. With the parking brake set, turn the ignition switch to the ON position.
2. Start the engine.
3. Apply the service brake.

NOTE: If the service brake is not applied while selecting a starting gear, the initial start gear will not be found and the driver will need to select Neutral and press the service brake while selecting the desired mode.

4. Select the desired mode and starting gear. (Inappropriate start gear selections are ignored to avoid damaging the transmission.)
5. Release the parking brake.
6. Release the service brake and apply the accelerator.

Power Down

1. Select Neutral on the shift control.

NOTE: If the gear display does not show a solid "N", neutral has not yet been obtained. Neutral should always be reached before powering down an UltraShift PLUS, except in cases of emergency.

2. Set the parking brake.
3. Turn off the ignition, and shut down the engine.

Reverse (R)

NOTE: If attempting to select a non-Neutral mode without applying the service brakes, the transmission will not shift into gear. To shift into gear, select Neutral, apply the service brakes, and select the desired mode again. Also, the vehicle will not engage reverse above 2 mph (3 km/h).

Reverse (R) is at the upper end of the four-position selector switch located at the end of the SmartShift control. To select R, press in the neutral lock button and move the selector switch to the position above neutral. The default Reverse gear is engaged.

NOTICE

Avoid launching the vehicle in high range. Launching the vehicle in high range increases the likelihood of clutch abuse and could be detrimental to clutch life.

Automatic Mode (AUTO)

In automatic drive mode (AUTO), upshifts and downshifts are made by the UltraShift PLUS without driver intervention. Press in the neutral lock button, move the selector switch to Drive (D), and press down on the throttle pedal. The transmission will shift automatically.

NOTE: If attempting to select a non-Neutral mode without applying the service brakes, the transmission will not shift into gear. To shift into gear, select Neutral, apply the service brakes, and select the desired mode again.

In Drive, the start gear is automatically selected. The selected start gear can vary depending on several

Automated Transmissions

vehicle inputs such as load, grade, and axle/transmission ratio. The start gear can be changed using the SmartShift control, provided the selected gear would allow the vehicle to launch without damaging the transmission. If the start gear is changed using the SmartShift control, it will be the default until the vehicle is powered down or the selection is changed again manually.

IMPORTANT: Prior to ascending a steep grade, either reduce the default start gear by one (using the SmartShift control) or apply full throttle for the duration of the grade so the vehicle maintains the proper engine and vehicle speed during the entire grade.

In Drive, the transmission automatically performs upshifts and downshifts. However, when the transmission is near the shift point, the shift can be forced using the upshift or downshift function of the SmartShift control.

NOTE: The transmission may deny a shift while ascending or descending a grade if the load of the vehicle and grade of the terrain in combination with the drivetrain ratio and engine torque fall outside of the acceptable range to perform a shift. If the shift is denied, a tone will sound.

Manual Mode (MAN)

In manual mode (MAN), the driver selects upshifts and downshifts instead of letting the UltraShift PLUS select them automatically. Manual shifting may be helpful when traversing a work site, railroad tracks, or steep grades, for example. To drive forward, press in the neutral lock button, move the selector switch to Drive (D), and press down on the throttle pedal. To shift up, pull the lever up (towards you); to shift down, push the lever down (away from you). The system holds the current gear unless a shift is requested or if the system initiates a manual mode override.

NOTE: The transmission may deny a shift while ascending or descending a grade if the load of the vehicle and grade of the terrain in combination with the drivetrain ratio and engine torque fall outside of the acceptable range to perform a shift. If the shift is denied, a tone will sound.

NOTE: If attempting to select a non-Neutral mode without applying the service brakes, the

transmission will not shift into gear. To shift into gear, select Neutral, apply the service brakes, and select the desired mode again.

Manual Mode Override

The system is equipped with a manual mode override function. If the vehicle is being "back driven" (for example, descending a grade and vehicle speed exceeds engine speed) and the engine speed is excessively high, the system will upshift automatically. Also, if the start gear is changed and it causes the engine to lug at takeoff, the system will override the current position and select the best available gear.

Low (L)

Low (L) is at the lower end of the four-position selector switch located at the end of the SmartShift control. Use Low when wanting to maximize engine braking and minimize the use of the brake pedal—for example, when driving down long grades or when coming to a stop. To select Low, press in the neutral lock button and move the selector switch to the L position. The lowest available start gear will be selected (the starting gear cannot be changed in Low).

If Low is selected while moving, the transmission will not upshift (unless the system initiates a Low override). The system will downshift at the earliest opportunity to provide maximum engine braking.

NOTE: If attempting to select a non-Neutral mode without applying the service brakes, the transmission will not shift into gear. To shift into gear, select Neutral, apply the service brakes, and select the desired mode again.

Low Override

The system is equipped with a Low override function. If the vehicle is being "back driven" (for example, descending a grade and vehicle speed exceeds engine speed) and the engine speed is excessively high, the system will upshift automatically. Also, if the start gear is changed and it causes the engine to lug at takeoff, the system will override the current position and upshift.

Clutch Abuse Protection

Although a vehicle equipped with an UltraShift PLUS uses an automated clutch, the clutch can still overheat and slip with improper use. The clutch abuse

protection feature helps protect the clutch if the automated clutch starts to overheat. When the clutch abuse protection feature initiates and sounds a warning tone, full clutch actuation must be completed quickly. If it is not completed quickly enough, the system will either open the clutch (if the throttle pedal is not being pressed) or close the clutch (if the throttle pedal is being pressed). If the abuse continues, the system will open the clutch and take away throttle control briefly to allow the clutch to cool down.

To protect the clutch:

- Select the lowest possible start gear for the application.
- Use Creep Mode when appropriate.
- Use the service brakes and the Hill Start Aid when launching on a grade.
- Minimize the time it takes to engage the clutch from rest.
- Do not use the throttle to hold the vehicle on a grade; use the service brakes.
- Do not use the throttle to stop roll back on an incline after Hill Start Aid disengages; use the service brakes, and then relaunch.
- Do not continually start and stop, especially when loaded; use a lower gear or Creep Mode.

Creep Mode

The Creep Mode function allows the vehicle to maintain a constant speed at engine idle without the driver holding the throttle pedal position. This mode is useful for very low-speed maneuvering and applications where steady vehicle speed is required. The vehicle speed is determined by the selected gear ratio operating at governed low engine idle speed. Any available gear may be selected, though the transmission will downshift or exit Creep Mode to prevent stalling if the engine lugs due to load conditions.

By default, Creep Mode can be activated while in Manual Mode or Low. Eaton's ServiceRanger diagnostic software can be used to enable Creep Mode in Automatic Mode and/or Reverse.

Engaging Creep Mode

To engage Creep Mode:

1. Select Low or Manual Mode and the desired gear (while stopped or moving).
2. Apply the throttle pedal to accelerate the vehicle until the clutch is closed (engaged).
3. Release the throttle pedal. The vehicle will continue moving at governed low engine idle speed.

Exiting Creep Mode

To exit Creep Mode, apply the throttle pedal to accelerate temporarily, or select a higher gear in Manual Mode. (Creep Mode can be resumed in the selected gear by releasing the throttle pedal.)

NOTE: The transmission will exit Creep Mode if the engine lugs 150 rpm below the governed low engine idle speed. In this case, a lower gear should be selected if available.

Hill Start Aid

UltraShift PLUS transmissions are equipped with a Hill Start Aid (HSA) feature to prevent the vehicle from rolling while on grades steeper than 3% and allow for a controlled launch. A grade sensor is used to determine when to engage the feature.

HSA is "on" by default. It can be turned off by pressing and releasing the override switch on the dash (see [Chapter 5](#)). HSA will turn back on after the first successful launch.

When the vehicle is stopped on a grade greater than 3% and in a forward mode or reverse, depress the service brakes then release them. The vehicle will begin to move after 3 seconds, and the clutch will perform partial engagements to slow the vehicle motion. Either step on the brake or apply the throttle to continue negotiating the grade.

Engine Overspeed Protection

The system will upshift if necessary to prevent engine overspeed in Drive, Manual, and Low.

Shuttle Shifting

Shuttle shifting from reverse to any forward mode is only allowed if the vehicle speed is approximately zero.

Automated Transmissions

Auto Start Gear Selection and Override

The UltraShift PLUS system uses various inputs to automatically select the best start gear in Drive and Manual. This selection can be changed using the SmartShift control; however, if the selection requested could cause damage or engine lugging, the request will be denied and a tone will sound.

Skip Shifting

When appropriate, the UltraShift PLUS system may skip shift in Drive. When prevailing conditions like load and grade allow, skip shifts can be performed in Manual mode using the SmartShift control.

Auto Neutral

The UltraShift PLUS system will automatically shift to neutral if the vehicle is left in Drive and the parking brake is set. "AN" will show on the gear display. To re-engage the transmission, select Neutral and then either Drive or Reverse on the shift control (it will re-engage regardless of whether the parking brake is released).

Automatic Traction Control

The UltraShift PLUS system requires the Automatic Traction Control (ATC) option to be enabled when driving in soft soil/sand to prevent wheel slippage and shifting issues. The ATC system has two modes: "normal" (for sand and loose road surface) and a mud/snow setting.

ATC Normal Mode

In normal mode, the system will engage the brakes on the wheel or side that the wheel slip is occurring to help the vehicle gain traction. The point at which the traction control will actuate the braking system increases with throttle: low throttle allows the system to brake the wheels earlier; heavy/full throttle raises the point of the acceptable wheel slip.

Adhere to the following points when driving in ATC normal mode:

- If using Automatic mode in soft soil and/or sand, maintain the engine speed between 1000 and 1300 rpm to prevent unnecessary upshifting.

- If using Manual mode in soft soil and/or sand, do not attempt an upshift and try to maintain the current gear.
- If the vehicle comes to a stop in the sand it may be necessary to back up prior to attempting forward movement.

ATC Mud/Snow Mode

To select the mud/snow mode, depress the ATC switch (see [Chapter 5](#)). This mode raises the wheel slip speed that is allowed before the traction control activates. The point at which the traction control will actuate the braking system increases with throttle: low throttle allows the system to brake the wheels earlier; heavy/full throttle raises the point of the acceptable wheel slip.

Load-Based Shifting

The UltraShift PLUS system is adaptive and will change the shift points based on grade, engine RPM, throttle position, and vehicle load. After changing loads or powering up, the system needs to relearn these inputs for the first few shifts to make the proper adjustments.

Coasting

When coasting to a stop on level terrain, the UltraShift PLUS system may not downshift into the lower gears. It will select a gear after the throttle is applied.

16

Drive Axles

| | |
|-----------------------------|------|
| Differential Locks | 16.1 |
| Two-Speed Drive Axles | 16.2 |

Drive Axles

Differential Locks

Tandem Drive Axles with Interaxle Differential Lock

An interaxle differential lock is standard on vehicles equipped with tandem drive axles. It is driver-actuated by means of a LOCK/UNLOCK control valve switch located on the dash in the cab (see [Chapter 5](#) for more information about the switch). Engagement can be at any speed, provided the wheels are not slipping or spinning. A red indicator illuminates when the interaxle differential lock is engaged.

In the UNLOCK position, there is differential action between the two axles. The differential compensates for different wheel speeds and variations in tire size. Keep the interaxle differential unlocked for normal driving on roads where traction is good.

In the LOCK position, the interaxle differential is locked out and the driveshaft becomes a solid connection between the two axles. Power entering the forward axle is also transmitted straight through to the rear axle, so both axles turn together at the same speed. The LOCK position should be used when the vehicle encounters poor traction conditions; however, it also increases drivetrain and tire wear and should be used only when improved traction is required.

Interaxle Differential Lockout Operation

NOTICE

Do not actuate the interaxle differential control valve while the tires are slipping. Do not operate the vehicle continuously with the interaxle differential locked during extended good road conditions. Using the IAD lock when wheels have good traction can harm the axle, wear the tires excessively, and increase fuel consumption. Release the IAD lock as soon as road conditions permit it.

To lock the interaxle differential and achieve maximum pulling power when approaching slippery or poor road conditions, move the lockout control valve to LOCK while maintaining vehicle speed, before encountering the poor road conditions. Let up momentarily on the accelerator to engage the differential lock. Proceed over poor road conditions with caution. Do not wait until traction is lost and the tires are spinning before locking the interaxle differential.

To unlock the interaxle differential, move the lockout control valve to UNLOCK while maintaining vehicle speed, after leaving the poor road conditions. Let up momentarily on the accelerator to allow the shift, then resume driving at normal speed.

Driver-Controlled Differential Lock (DCDL)

Some vehicles are equipped with a driver-controlled differential lock (DCDL) that is operated by a dash switch in the cab (see [Chapter 5](#) for more information about the switch). The differential lock provides maximum traction for slippery conditions by forcing the wheels on a drive axle to rotate together. The differential lock should be engaged when the vehicle is stopped or moving at a low, constant speed and the wheels are not spinning, slipping, or losing traction. Do not exceed 25 mph (40 km/h) when the differential lock is engaged.

On tandem axles there are three possible DCDL options:

- Forward-rear carrier only
- Rear-rear carrier only
- Both rear carriers.

An indicator light comes on when the DCDL is engaged. An optional buzzer can also be used to indicate DCDL engagement.

The DCDL provides maximum traction under slippery conditions. When the DCDL is engaged, the clutch collar completely locks the differential case, gearing, and axle shafts together, maximizing traction of both wheels and protecting against spinout. Under normal traction conditions, do not engage the DCDL; operate the axle with differential action between both wheels.

 **WARNING**

Be especially careful when driving under slippery conditions with the differential locked. Though forward traction is improved, the vehicle can still slip sideways, causing possible loss of vehicle control, personal injury, and property damage.

Main Differential Lock Operation

NOTICE

The differential lock should be engaged when the vehicle is stopped or moving at a low, constant speed and the wheels are not spinning, slipping, or losing traction. Engagement at high speed or power can damage the axle(s).

Do not permit rear wheels to spin freely for more than ten seconds when traction is lost. Shift into LOCK to prevent damage to interaxle and main differentials.

To lock the main differential and obtain maximum traction under slippery conditions, move the control switch to the lock position.

NOTE: On some vehicles, the differential lock system is connected through the low speed range of the transmission. If this system is used, the transmission must be in the low speed range for the differential to fully lock.

If the vehicle is moving, maintain a constant vehicle speed while engaging the differential lock. Briefly let up on the accelerator to relieve torque on the gearing, allowing the differential to fully lock. The indicator light should come on and the buzzer should sound on vehicles so equipped. When the differential is fully locked, the turning radius will increase because the vehicle understeers. See Fig. 16.1. Drive cautiously and do not exceed 25 mph (40 km/h).

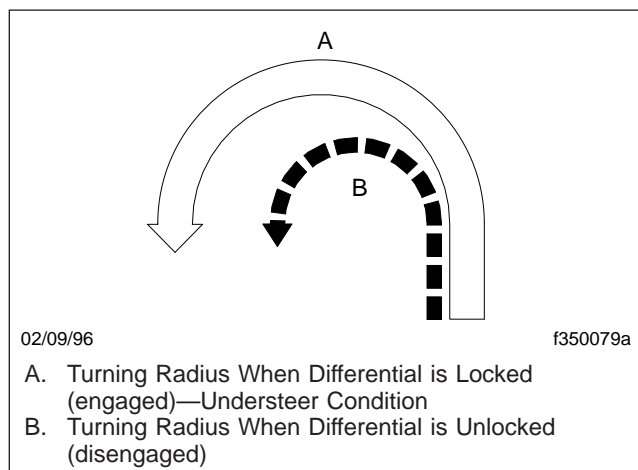

Fig. 16.1, Turning Radius

To unlock the main differential, move the control switch to the unlock position. Briefly let up on the accelerator to relieve torque on the gearing, allowing the differential to fully unlock.

NOTE: If the differential lock system is connected through the low speed range of the transmission, shifting out of low speed range will also unlock the differential.

When the differential lock disengages, the indicator light will go off and the buzzer will stop.

Single Drive Axles with Traction Equalizer

Some single drive axles are equipped with a traction equalizer that is a load-sensing, self-actuating feature. A traction equalizer provides normal differential action where traction is good. When one wheel begins to spin faster than the other, clutch plates in the differential housing automatically engage, delivering power to both wheels. There is no operator control with this feature.

A traction equalizer occasionally tends to slip in a jerking motion, producing irregular intervals of sharp noises. This generally occurs when the vehicle is operating at low speeds on fairly sharp turns. This condition is corrected by adding a friction modifier to the axle lubricant. This additive tends to reduce the static coefficient of friction to a value equal to, or lower than, the sliding coefficient.

See Group 35 of the *Cascadia™ Maintenance Manual* for additional information on friction modifiers and when to add them to axle lubricants.

CAUTION

Tire sizes on both rear wheels should be the same on axles equipped with a traction equalizer. If not, excessive wear may occur in the traction equalizer.

Two-Speed Drive Axles

Axle Shift

CAUTION

To prevent transmission and axle damage, make sure the automatic transmission is in high range

Drive Axles

when performing an axle shift with the vehicle moving.

Axle shift is a function installed on vehicles with two-speed axles to allow the use of the low speed range when greater traction and maximum pulling power is needed at low engine speed (rpm).

Under normal operating conditions, the vehicle is operated using the high-speed gear ratios of the axle. Under extreme weather or off-road conditions, at low speed and rpm and/or to pull heavy loads, the vehicle must be operated using the low-speed, or reduction, gear ratios of the axle.

Axle Shift Switch

The axle shift switch is a two-position rocker switch (Fig. 16.2) installed on vehicles with two-speed axles.

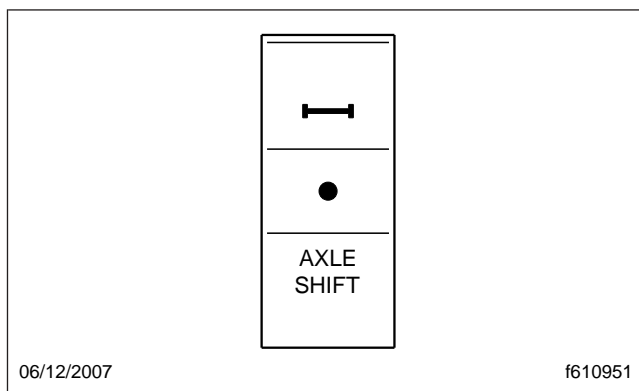

Fig. 16.2, Axle Shift Switch

To shift the axle from low speed to high speed, press the top of the switch. To turn the axle shift off (switch from high speed back to low speed), press the bottom of the switch. When the axle has shifted speed, the LED turns off.

When the panel lights are on, the AXLE SHIFT legend is backlit in green.

IMPORTANT: If the LED in the switch begins to blink during normal operation, when the switch has not been activated, this indicates an error condition. Bring the vehicle to an authorized Freightliner service facility as soon as possible.

When the axle shift switch is pressed, three responses are possible: a normal response, a slow response, and an abnormal response.

Normal Response: The LED in the switch blinks until the axle shifts speed. At this point, the LED comes on steady and stays illuminated. In normal operation, the axle may shift so quickly that the blinking of the switch is barely noticeable.

If operation of the switch is not possible for any reason (interaxle lock is on, ignition is turned off, etc.), the LED will stop blinking and turn off.

Slow Response: If operation of the switch is slowed for any reason (by cold weather, low air pressure, etc.), the switch will continue to blink until the axle shifts. As in the normal response, the LED comes on steady and stays illuminated.

Abnormal Response: If the LED blinks for more than 30 seconds, the axle shift function/mechanism may not be operating correctly. Bring the vehicle to an authorized Freightliner service facility for testing.

Axle Switch Interlock

NOTE: On vehicles with tandem drive axles, there is an interlock that prevents an axle from shifting speed whenever the interaxle lock is on.

If the axle shift switch is pressed when the interaxle lock is on, the axle shift will not be completed. The LED does the following:

- If the LED is off, the LED comes on briefly and turns off again.
- If the LED is on, it stays on.

To complete the axle shift, turn off the interaxle lock and press the axle shift switch again. If still needed, the interaxle lock can then be reactivated.

17

Steering System

| | |
|---|------|
| Power Steering System General Information | 17.1 |
| Power Steering Systems | 17.1 |

Steering System

Power Steering System General Information

When there is no load on the vehicle, and the front tires are pointed straight ahead, the steering wheel spokes should be centered, ± 10 degrees, as shown in Fig. 17.1. See Group 46 of the *Cascadia™ Workshop Manual* for steering adjustment procedures.

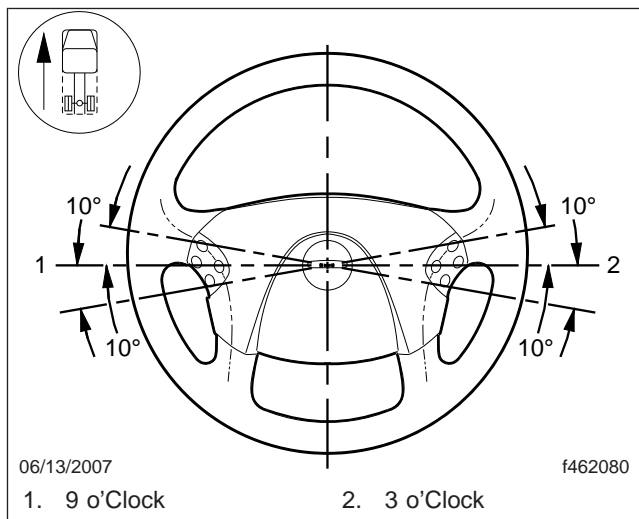

Fig. 17.1, Proper Steering Wheel Position (with tires pointed straight ahead)

CAUTION

Never steam clean or high-pressure wash the steering gear. Internal damage to gear seals, and ultimately the steering gear, can result.

WARNING

Driving the vehicle without the power-assist feature of the steering system requires much greater effort, especially in sharp turns or at low speeds, which could result in an accident and possible injury.

Drivers should carefully use the power available with a power steering system. If the front tires become lodged in a deep chuckhole or rut, drive the vehicle out, instead of using the steering system to lift the tires from the hole. Also, avoid turning the tires when they are against a curb, as this places a heavy load on steering components and could damage them.

Power Steering Systems Steering Gear System

The steering gear system includes the power steering gear, hydraulic hoses, power steering pump, reservoir, and other components. Some models are also equipped with a separate hydraulic power cylinder on the right side of the front axle, or a right-hand slave gear (such as the TRW RCH-45). The power steering pump, driven by the engine, provides the power assist for the steering system. If the engine is not running, there is no power assist. If the power-assist feature does not work due to hydraulic fluid loss, steering pump damage, or some other cause, bring the vehicle to a safe stop. Do not drive the vehicle until the cause of the problem has been corrected.

Rack and Pinion Steering System

The rack and pinion steering gear is mounted to the front axle with two brackets, and connected by tie-rod ends to the axle steering arms. When the steering wheel is turned, the intermediate steering shaft turns the input shaft, rotating the torsion bar and the valve. When the valve turns, power steering fluid is redirected and provides power assist to turn the pinion gear meshed with the rack teeth, moving the rack left or right. The rack, with a tie-rod at each end, then moves the steering arms on the axle, and pivots the wheels.

This design provides drivers with more responsive steering, with increased performance and "road feel." It virtually eliminates steering issues when the driver hits a bump (bumpsteer), and significantly reduces roll steer when a vehicle goes into a curve. Wandering is significantly reduced as well, so the vehicle tends to drive straight on the highway. It has a lower steering ratio, which means drivers don't have to turn the steering wheel as much to get the wheels to turn a given distance. Overall, rack and pinion steering greatly improves steering response, and reduces driver effort and fatigue.

18

Fifth Wheels

| | |
|---|------|
| Fifth Wheels, General Information | 18.1 |
| Fifth Wheel Coupling | 18.1 |
| Fifth Wheel Uncoupling | 18.4 |
| Fifth Wheel Slide | 18.7 |

Fifth Wheels

Fifth Wheels, General Information

WARNING

Do not use any fifth wheel that fails to operate properly. Doing so may cause loss of vehicle control, possibly resulting in severe personal injury or death.

Air-Suspension Dump Valve

The air-suspension dump valve may be used to adjust the tractor height to aid with coupling to or uncoupling from a trailer. See [Fig. 18.1](#). When the switch is set to LOWER, the air-suspension dump valve deflates the air springs to lower the rear of the vehicle. In the AUTO position, the automatic ride-control valves operate for normal driving.

WARNING

Never exhaust air from the suspension while driving. The suspension will not absorb road shocks, possibly damaging components, and vehicle handling may be compromised. This could result in loss of vehicle control, possibly resulting in severe personal injury or death.

NOTICE

Do not operate the vehicle over uneven ground such as ramps, speed bumps, curbs, etc. with the air springs deflated. Doing this may lead to air bag separation from the piston, preventing the suspension air springs from inflating.

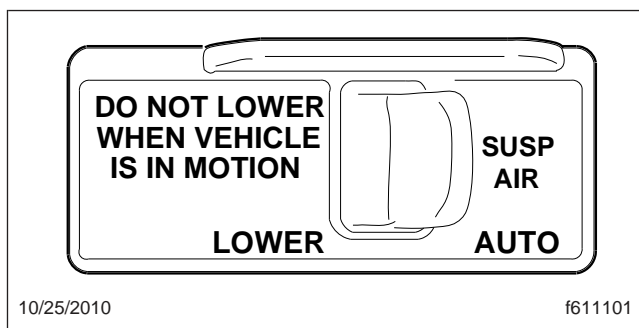

Fig. 18.1, Air-Suspension Dump Valve

Fifth Wheel Lubrication

WARNING

Keep the fifth wheel plate lubricated to prevent binding between the tractor and trailer. A binding fifth wheel could cause erratic steering and loss of vehicle control, possibly resulting in personal injury or death.

The standard fifth wheel plate must be kept well lubricated with chassis grease to prevent friction and binding between the tractor fifth wheel plate and the trailer.

For a low-lube fifth wheel plate, inspect the condition of the low-lube pads. There should be no damaged or missing pieces. Slight puckering at the outside edges is normal.

For lubrication instructions, see **Group 31** of the *Cascadia® Maintenance Manual*.

Fifth Wheel Coupling

Fifth wheel coupling is activated with the lock control handle located on either the right side or left side of the fifth wheel. Coupling has successfully occurred when the kingpin has been forced into the jaws and the lock control handle has moved to the locked position.

NOTICE

Some fifth wheels may be mounted on sliding rails. Before attempting to couple a trailer to a sliding fifth wheel, the slide feature must be locked to prevent the top plate from sliding rapidly forward or rearward, causing damage to the fifth wheel or kingpin.

Fontaine and Holland Fifth Wheels Coupling

1. Chock the front and rear of the trailer tires to prevent the trailer from moving.
2. Ensure the fifth wheel jaw is fully open and the operating rod is in the unlocked position. See [Fig. 18.2](#) or [Fig. 18.3](#).
3. Make sure the fifth wheel top plate is tilted so the ramps are as low as possible.

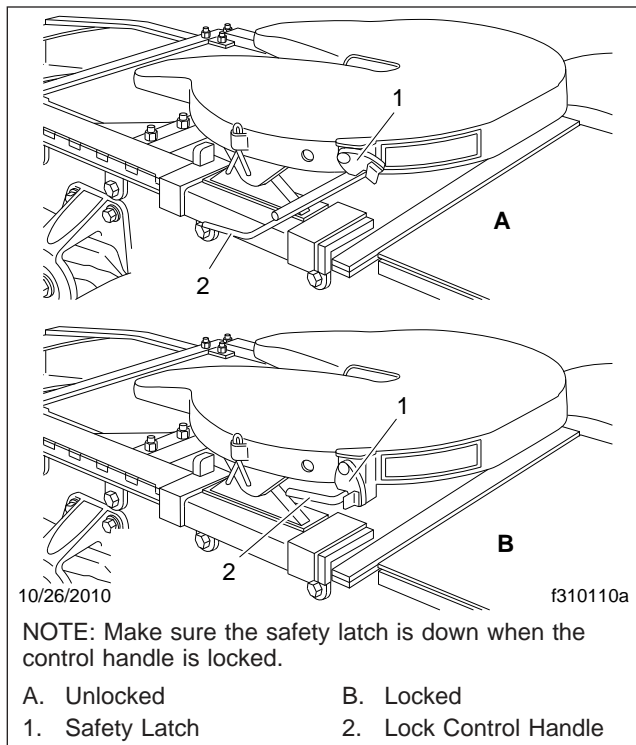

Fig. 18.2, Fontaine Locking Mechanism

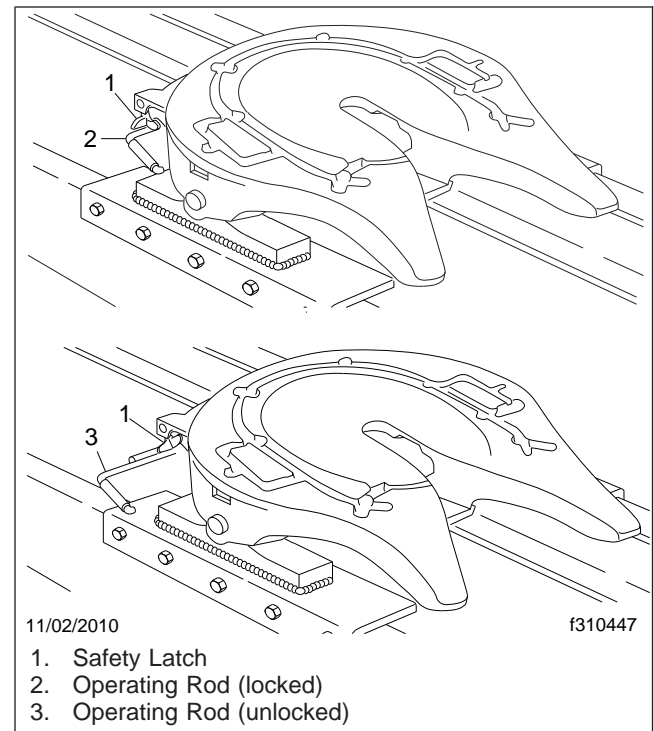

Fig. 18.3, Holland Simplex SE Locking Mechanism

- Position the tractor so that the center of the fifth wheel is in line with the trailer kingpin. The kingpin should be in a position to enter the throat of the locking mechanism.

NOTICE

Attempting to couple at the wrong height may cause improper coupling, which could result in damage to the fifth wheel or kingpin.

- Adjust the trailer height if required.

For a standard fifth wheel plate, the trailer should contact the fifth wheel approximately 4 to 8 inches (10 to 20 cm) behind the fifth wheel pivot. See [Fig. 18.4](#).

For a low-lube fifth wheel plate, the fifth wheel must slide freely under the trailer, and the trailer should contact the fifth wheel at the pivot. See [Fig. 18.5](#).
- With the fifth wheel lock opening aligned with the trailer kingpin, back the tractor slowly toward the trailer. After sliding under the trailer, STOP to

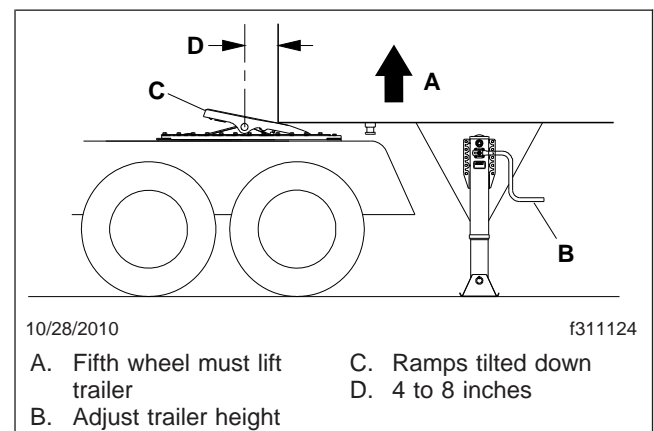

Fig. 18.4, Trailer Connection Point, Standard Fifth Wheel

prevent from hitting the kingpin too hard, then resume backing slowly until the fifth wheel locks.

On a standard fifth wheel, the fifth wheel must lift the trailer.

On a low-lube fifth wheel, do not lift the trailer as this may damage the fifth wheel plate.

Fifth Wheels

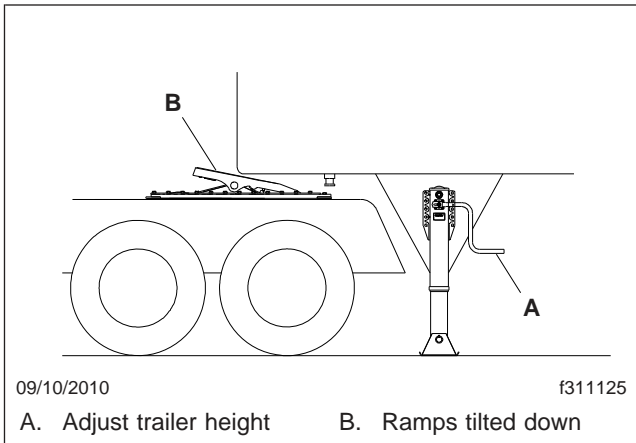

Fig. 18.5, Trailer Connection Point, Low-Lube Fifth Wheel

7. Apply the tractor parking brakes.

WARNING

A visual inspection is required by law. Some improper couplings can pass a pull test. Sound is not reliable. Get out of the cab and look. Incorrect coupling could cause the trailer to disconnect, possibly resulting in serious personal injury or death.

8. Perform a coupling inspection, checking that there is no gap between the bottom of the trailer and the fifth wheel, and that the kingpin is securely locked. See **Fig. 18.6**
When lockup has occurred, the fifth wheel control handle moves to the locked position. Make sure that the safety latch is down over the lock control handle to hold the control handle in the locked position. (The safety latch will only rotate down if the operating rod is fully retracted in the locked position.) See **Fig. 18.2** for Fontaine fifth wheels. See **Fig. 18.3** for Holland fifth wheels.
9. Release the tractor parking brakes. Test for kingpin lockup slowly inching the tractor forward, pulling on the trailer against the chocks.
10. After lockup is completed, connect the tractor-to-trailer air system lines and the electrical cable to the trailer. Take care to prevent dirt or foreign material from entering the air system lines.

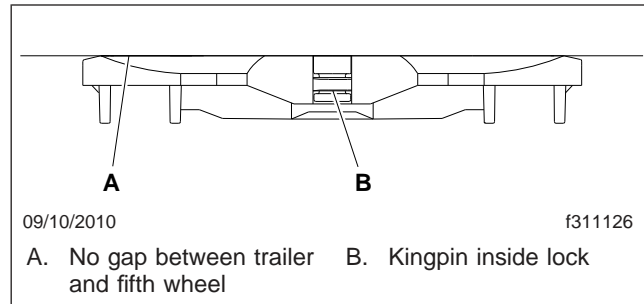

Fig. 18.6, Coupling Inspection

NOTICE

Always make sure the connection hanger keeps the trailer air hoses and electrical cables positioned so that they do not rub on anything. Rubbing may wear through hoses or cables, resulting in air leaks, or exposed or broken wires, potentially affecting trailer brake or electrical systems.

11. Charge the air brake system with air, checking that the air connections do not leak.

WARNING

Incorrect fifth wheel lock adjustment could cause the trailer to disconnect, possibly resulting in serious personal injury or death.

12. With the trailer wheels chocked and the brakes set, check for clearance between the kingpin and the fifth wheel jaws by moving the tractor forward and backward against the locked kingpin. If slack is present, uncouple the trailer and have the fifth wheel inspected and adjusted by a certified technician.

Jost Fifth Wheel Coupling

1. Tilt the ramp down.
2. Open the kingpin locks. See **Fig. 18.7**.
3. Back the vehicle close to the trailer, centering the kingpin on the fifth wheel.
4. Chock the trailer wheels.
5. Connect the air lines and electrical cable.
6. Ensure that the red trailer air supply valve (trailer brake) is pulled out, and that the trailer parking

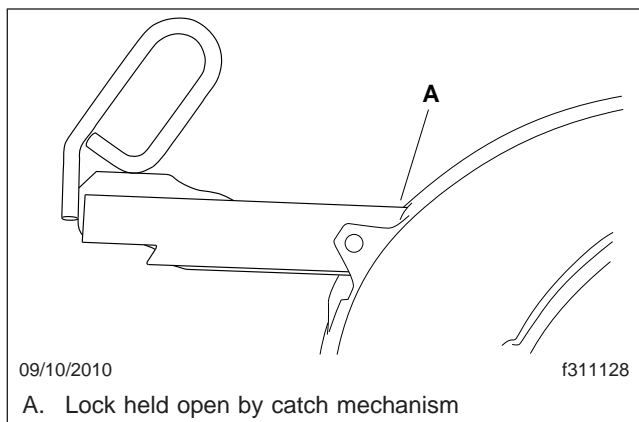

Fig. 18.7, Jost Release Handle Unlocked

brakes are set. See [Chapter 5](#) in this manual for operation of the dash-mounted brake controls.

NOTICE

Attempting to couple at the wrong height may cause improper coupling, which could result in damage to the fifth wheel or kingpin.

- Adjust the trailer height (if required).

For a standard fifth wheel plate, the trailer should contact the fifth wheel approximately 4 to 8 inches (10 to 20 cm) behind the pivot. See [Fig. 18.4](#).

For a low-lube fifth wheel plate, the fifth wheel must slide freely under the trailer, and the trailer should contact the fifth wheel at the pivot. See [Fig. 18.5](#).

- Back the tractor under the trailer.

On a standard fifth wheel, the fifth wheel must lift the trailer.

On a low-lube fifth wheel, do not lift the trailer as this may damage the fifth wheel plate.

- After sliding under the trailer, STOP to prevent from hitting the kingpin too hard, then resume backing slowly until the fifth wheel locks.

WARNING

A visual inspection is required by law. Some improper couplings can pass a pull test. Sound is not reliable. Get out of the cab and look. Incorrect coupling could cause the trailer to discon-

nect, possibly resulting in serious personal injury or death.

- Apply the tractor parking brake, then perform a physical check for positive kingpin lockup, and that there is no gap between the trailer and the fifth wheel. See [Fig. 18.6](#).
- Ensure that the release handle is in the locked position adjacent to the casting. See [Fig. 18.8](#).
- Release the tractor parking brakes and test for kingpin lockup by slowly moving the tractor forward, pulling on the trailer against the chocks.

Fifth Wheel Uncoupling

Manual Uncoupling

- Apply the tractor and trailer parking brakes.
- Chock the trailer rear wheels.
- Lower the trailer landing gear until the weight is removed from the fifth wheel.
- Disconnect the tractor-to-trailer air system lines and electrical cable. Plug the air lines to prevent dirt or foreign material from entering the lines.
- Verify that both the yellow parking-brake and red trailer-air-supply knobs are out, the tractor and trailer parking brakes are set, and that the trailer is prepared for uncoupling.
- Release the kingpin locking mechanism following the instructions for each manufacturer below.
 - Fontaine:** Lift the safety latch and pull the lock control handle to the unlocked position. See [Fig. 18.2](#).
 - Holland:** In the locked position the safety indicator swings freely over the operating rod. See [Fig. 18.9](#), View A.

To unlock the mechanism, manually rotate the safety indicator toward the rear of the fifth wheel. See [Fig. 18.9](#), View B.

Pull the operating rod out. When the upper operating rod shoulder is outside the slot, raise the handle and place the shoulder of the upper rod against the plate casting, above the slot. See [Fig. 18.9](#), View C.

Fifth Wheels

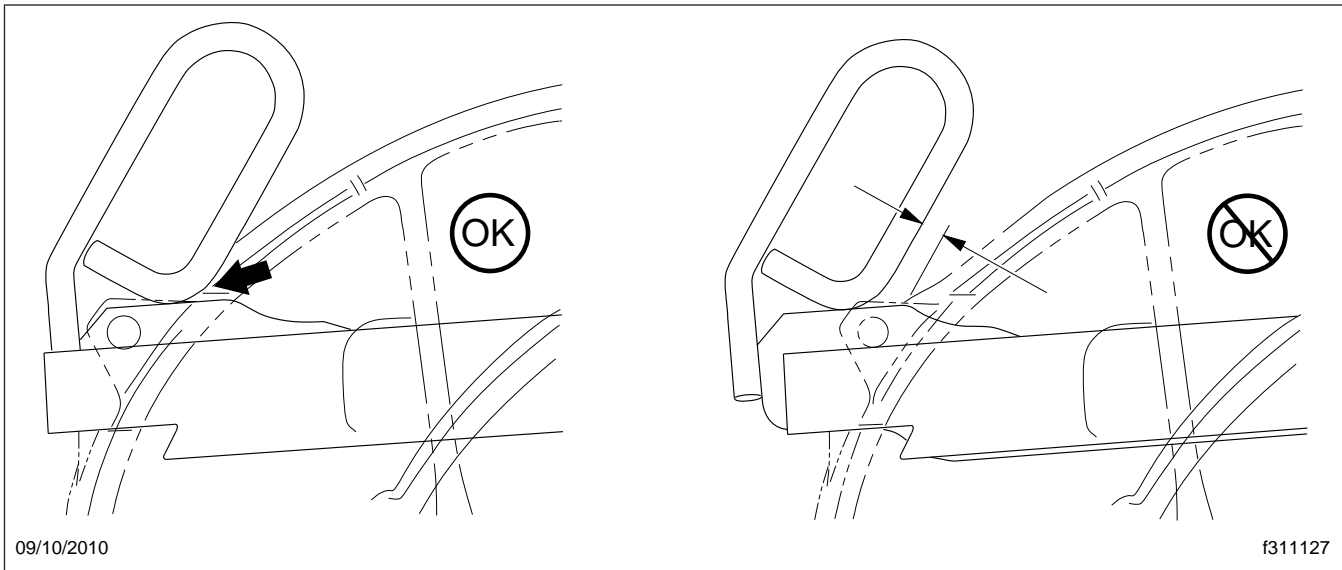

Fig. 18.8, Jost Release Handle Locked

The fifth wheel is now in the lockset position and is ready for uncoupling. As the tractor pulls away from the trailer the kingpin forces the jaw to rotate, contacting the lock. Continued rotation of the jaw forces the lock to move outward, and drops the upper rod back into the slot. See Fig. 18.9 View D. The wheel is now ready for coupling.

- 6.3 **Jost:** Pull the retractable handle out, then secure it in the open position with the catch. See Fig. 18.7.
7. Release the tractor parking brake then drive out slowly, allowing the trailer to slide down the fifth wheel and pick-up ramps.

Air-Actuated Uncoupling

An air-actuated kingpin release valve is optional with all fifth wheels. See Fig. 18.10.

NOTE: In the event of an air system failure, air-actuated kingpins can be manually released following the instructions for manual unlocking.

WARNING

Once the kingpin release valve has been pulled the kingpin lock is released. The vehicle **MUST NOT** be driven with the trailer until the trailer has

been uncoupled and coupled again. Failure to do so may result in separation of the trailer from the tractor, possibly causing serious personal injury or death.

Preparing the Trailer for Uncoupling

Before using the air valve to unlock a fifth wheel kingpin, prepare the trailer as follows.

1. Apply the tractor and trailer parking brakes.
2. Chock the trailer rear wheels.
3. Lower the trailer landing gear until the weight is removed from the fifth wheel.
4. Disconnect the tractor-to-trailer air lines and electrical cable. Plug the air lines to prevent dirt or foreign material from entering the lines.

Fontaine and Holland Fifth Wheels Air-Activated Kingpin Unlock

1. Verify that both the yellow parking-brake and red trailer-air supply knobs are out, the tractor and trailer parking brakes are set, and that the trailer is prepared for uncoupling.

NOTE: On Fontaine and Holland fifth wheels, if the tractor parking brake is not set, the air-actuated kingpin-release valve will not activate.

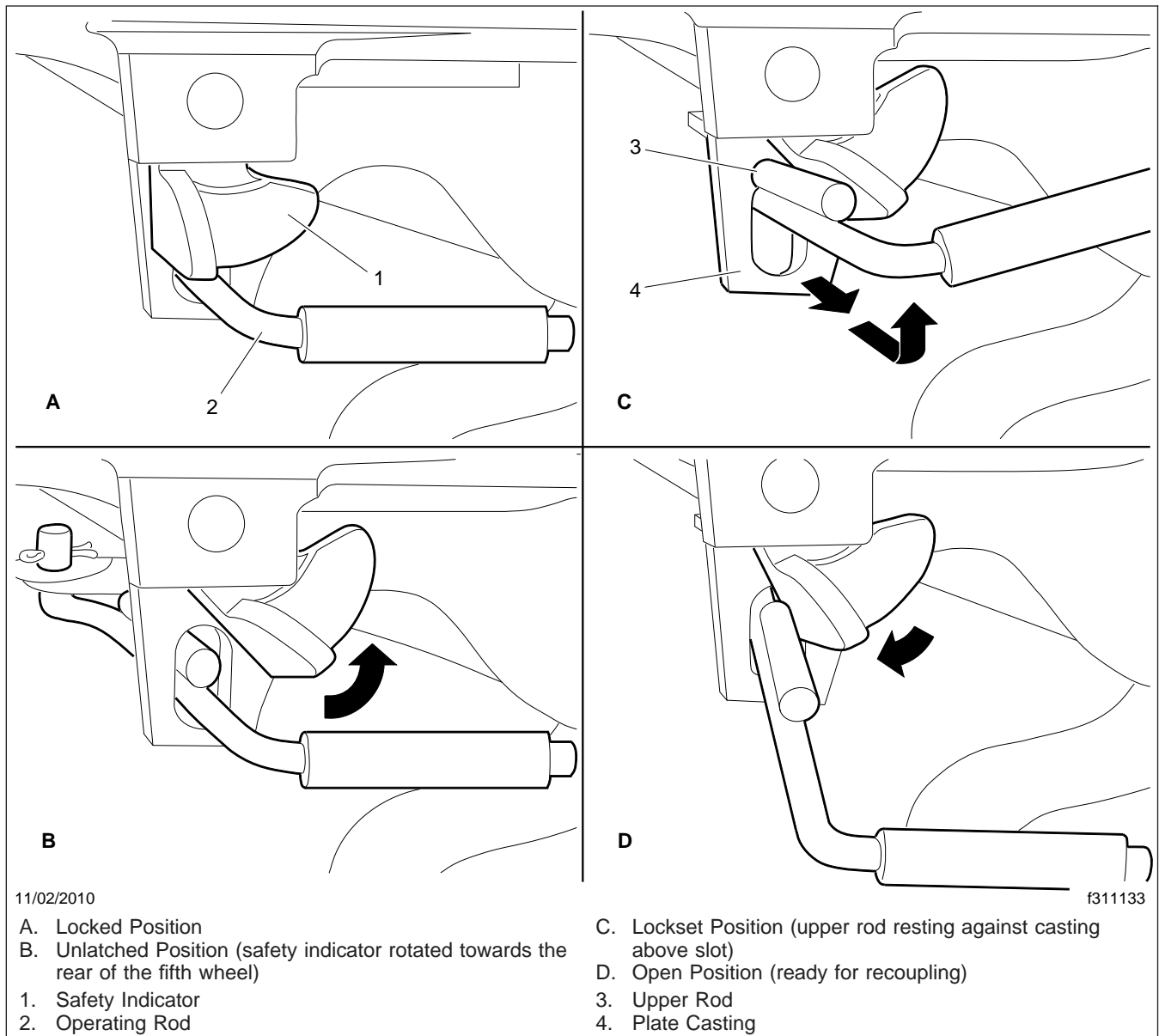

Fig. 18.9, Holland Kingpin Locking Mechanism

2. Pull and hold the kingpin release valve (**Fig. 18.10**) until the kingpin lock mechanism opens and locks in place.
3. Release the pull valve.
4. Release the tractor parking brake.
5. Drive out from under the trailer.

Jost Fifth Wheels Air-Activated Kingpin Unlock

1. Verify that both the yellow parking-brake and red trailer-air-supply knobs are out, the tractor and trailer parking brakes are set, and that the trailer is prepared for uncoupling.

Fifth Wheels

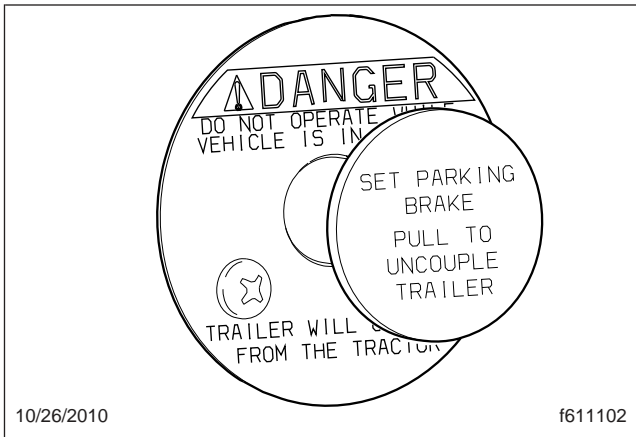

Fig. 18.10, Air-Actuated Kingpin Release Valve

NOTE: With Jost fifth wheels, if the trailer parking brake is not set the air-actuated valve will not activate.

2. Release the tractor parking brake.
3. Pull and hold the kingpin release valve, then drive forward slowly.
4. After the trailer has slid down the fifth wheel and pick-up ramps, release the pull valve.

Fifth Wheel Slide

WARNING

Adjust the fifth wheel slide correctly, and do not overload any tractor axle by incorrectly loading the trailer. Incorrect slide adjustment or improper axle loading could cause erratic steering and loss of vehicle control, possibly resulting in serious personal injury or death.

On sliding fifth wheel assemblies, the fifth-wheel plate is attached to rails that allow forward and rearward movement of the fifth wheel to optimally distribute the load across the axles. Slots are evenly spaced along the slide rails, and retractable wedges are positioned through the slots to hold the fifth wheel in the desired position.

The amount of load distribution on the front steering axle and rear drive axle(s) will have a direct effect on the steering control of the vehicle. Determine the front and rear axle weights by weighing the vehicle on scales designed for this purpose.

The maximum axle weight ratings are shown on the Federal Motor Vehicle Safety Standard (FMVSS) label or Canadian Motor Vehicle Safety Standard (CMVSS) label attached to the left rear door post of the tractor. The desired load on the axle is no less than 80 percent of the maximum axle weight rating, but in no instances should the axle load exceed the maximum axle weight rating given on the FMVSS or CMVSS label.

Manual Slide Operation

The manual slide feature is operated from the fifth wheel plate with a manual release handle using the following procedure. See Fig. 18.11.

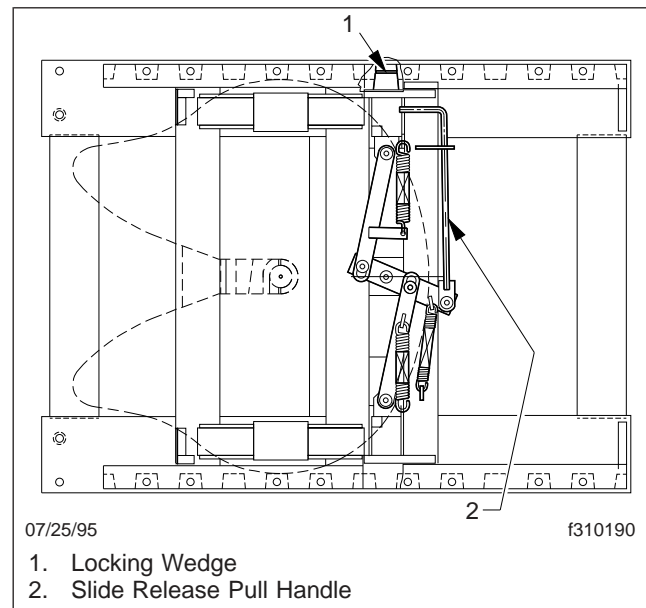

Fig. 18.11, Manual Release Sliding Fifth Wheel (Fontaine shown)

1. Stop the tractor and trailer in a straight line on level ground. Pull the red trailer air supply knob to apply the trailer parking brakes.
2. Apply the tractor parking brake, then release the sliding mechanism using the appropriate method for the fifth wheel manufacturer.
 - 2.1 **Fontaine:** Lift the slide release pull handle to disengage it from the guide plate. Then, pull out the handle until it is in the unlocked position and can be positioned against the guide plate to hold it out. The

handle will stay in the unlocked position until it is manually disengaged from the guide plate. See **Fig. 18.12**.

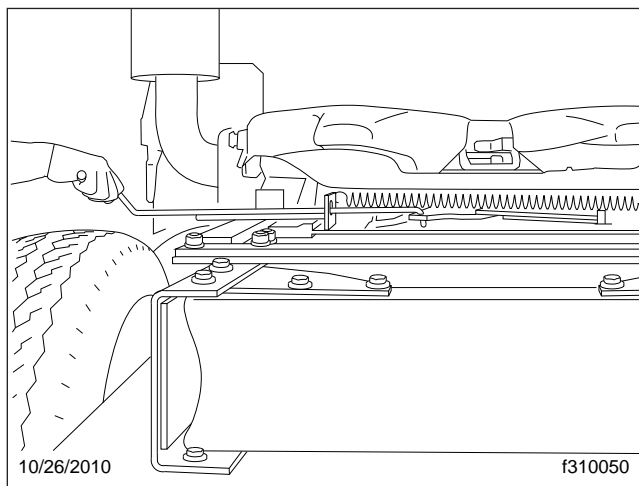

Fig. 18.12, Releasing the Sliding Fifth Wheel, (Fontaine)

- 2.2 **Holland:** Pull the operating rod out. Make sure both side plungers have released. See **Fig. 18.13**.

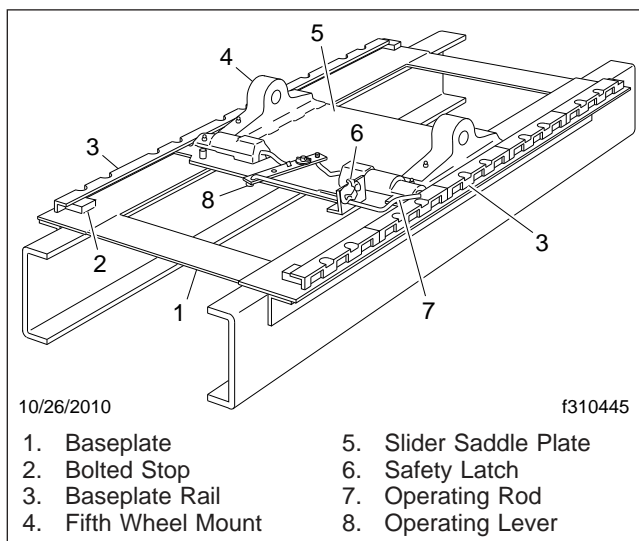

Fig. 18.13, Sliding Fifth Wheel Manual Release, (Holland Simplex)

3. Lower the trailer landing gear just enough to remove the weight from the tractor.
4. Chock the front and rear of the trailer tires to prevent the trailer from moving.

5. Release the tractor parking brakes, then slowly move the tractor forward or backward until the fifth wheel is in the desired location.

NOTICE

When moving the fifth wheel to the desired position, be sure the trailer landing gear will not at any time come in contact with the tractor frame or other components. Make sure that the front of the trailer will not come in contact with the rear of the cab or with other components if they extend beyond the rear of the cab.

WARNING

Check that the locking wedges have seated in the slots. Failure to achieve complete lockup may allow disengagement of the tractor from the trailer, possibly resulting in serious personal injury or death.

6. Apply the tractor parking brakes, then lock the sliding member in position using one of the following methods:
 - 6.1 **Fontaine:** Disengage the slide release pull handle from the guide plate. The slide release pull handle is spring-loaded in the locked position and will seek the locked position when disengaged from the guide plate. After the slide release pull handle returns to the fully locked position, visually and physically check the locking wedges to make sure they are fully inserted into the slots in the slide rails. Make sure the handle is locked in position against the guide plate.
 - 6.2 **Holland:** Raise the operating rod so that it is free to move inward. Make sure that the lock pins have seated in the base plate rail holes and the operating rod moves into the locked position.

NOTE: The fifth wheel may need to be moved slightly to enable the locking wedges to enter the fully locked position.

Fifth Wheels

Air Slide Operation

The slide feature may be operated with an air switch mounted in the dash, that operates an air cylinder that locks and unlocks the slide. See [Fig. 18.14](#).

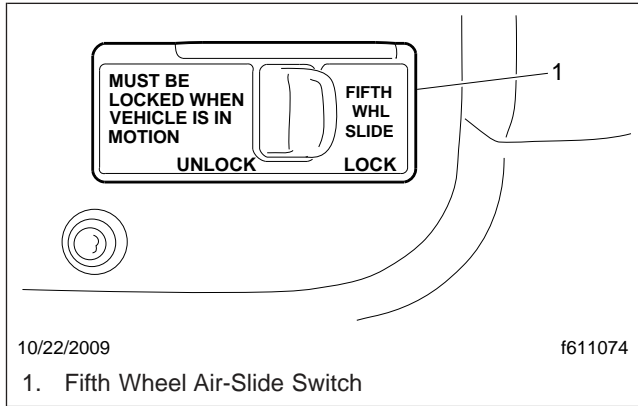

Fig. 18.14, Air-Slide Switch

1. Set the air-slide switch ([Fig. 18.14](#)) to UNLOCK. Ensure the locking plungers have released. See [Fig. 18.15](#).
For Jost fifth wheels, the mechanism activates as shown in [Fig. 18.16](#).

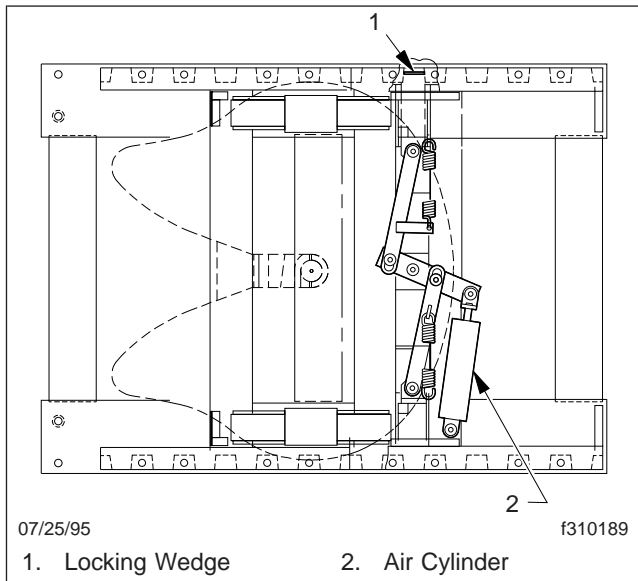

Fig. 18.15, Air-Operated Sliding Fifth Wheel (Fontaine shown)

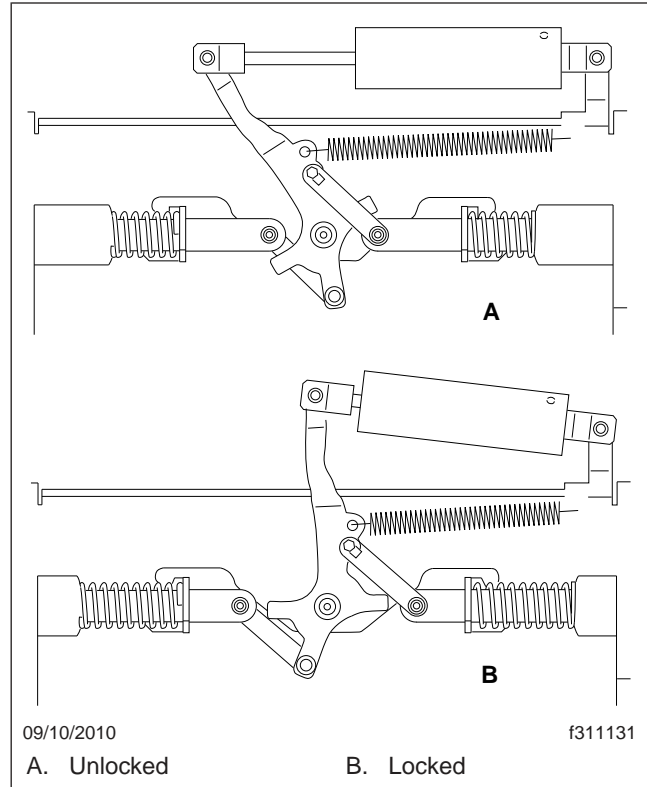

Fig. 18.16, Jost Sliding Fifth Wheel

2. Lower the trailer landing gear just enough to remove the weight from the tractor.
3. Pull the red trailer-air-supply knob to set the trailer-parking brakes.
4. Slowly move the tractor forward or backward until the fifth wheel is in the desired location.

NOTICE

Ensure the trailer landing gear does not come in contact with the tractor frame or other components, and that the front of the trailer will not come in contact with the rear of the cab or other components if they extend beyond the rear of the cab.

5. Apply the tractor parking brakes.



Check that the locking wedges have seated in the slots. Failure to achieve complete lockup may

allow disengagement of the tractor from the trailer, possibly resulting in serious personal injury or death.

6. Set the air-slide switch to LOCK. Visually inspect the locking wedges or plungers to make sure that they are fully inserted in the slide rail slots. Verify that the plungers have engaged by tugging the tractor forward while the trailer brakes are locked and the wheels are chocked.

NOTE: The fifth wheel may need to be moved slightly to enable the locking wedges to fully lock.

19

Trailer Couplings

| | |
|---------------------------------|------|
| Air-Suspension Dump Valve | 19.1 |
| Holland Trailer Coupling | 19.1 |

Trailer Couplings

Air-Suspension Dump Valve

The air-suspension height switch may be used to aid in connecting or disconnecting from a trailer. When the switch is set to LOWER, the air-suspension dump valve deflates the air springs to lower the rear of the vehicle. In the AUTO position, the automatic ride-control valves operate for normal driving.

NOTICE

Do not operate the vehicle over uneven ground such as ramps, speed bumps, curbs, etc. with the air springs deflated. Doing this may lead to air bag separation from the piston, preventing the suspension air springs from reinflating.

NOTICE

Never exhaust air from the suspension while driving. When the air is exhausted, the suspension will not absorb road shocks, and components may be damaged.

Holland Trailer Coupling

General Information

The Holland PH-T-60-AL trailer coupling is designed for use with trailers having a maximum gross weight of 10,000 lb. See [Fig. 19.1](#). It is a rigid-type pintle hook, used only on tractor applications, and is fastened to the rear closing crossmember of the vehicle. It is a non-air-adjusted coupling.

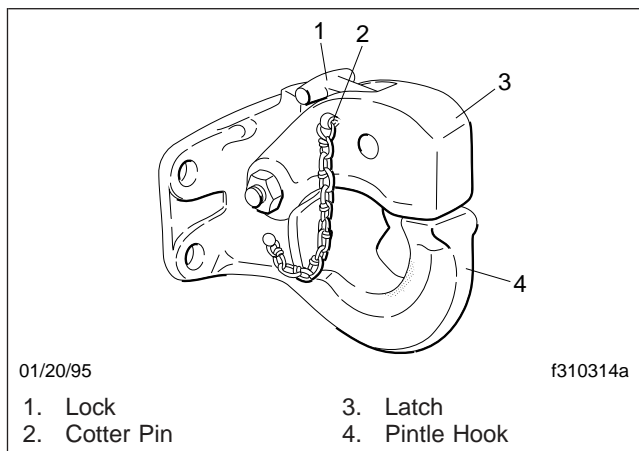

Fig. 19.1, Holland PH-T-60-AL Trailer Coupling

Operation

Trailer Hookup

1. Chock the front and rear tires of the trailer.
2. Remove the cotter pin, then lift the lock and raise the latch.
3. Back up the vehicle, until the drawbar eye is over the pintle hook.
4. Lower the trailer, until the drawbar eye rests on the pintle hook.
5. Close the latch, then insert the cotter pin.
6. Hook up the trailer electrical and air lines.
7. Remove the chocks from the trailer's tires.

Trailer Release

1. Apply the tractor and trailer parking brakes.

WARNING

Do not use the trailer air supply for parking trailers not equipped with spring parking brakes. This applies the trailer service brakes only. As air bleeds from the trailer brake system, brake application is lost. This could allow the unattended vehicle to roll away, possibly resulting in serious personal injury or death.

2. Chock the front and rear tires of the trailer.
3. Disconnect the trailer air and electrical lines. Plug the air lines to keep out dirt.
4. Take the weight of the trailer drawbar off the pintle hook.
5. Open the latch, by first removing the cotter pin, then lift up the lock and raise the latch.
6. Slowly drive the vehicle away from the trailer.

20

Pre- and Post-Trip Checklists

| | |
|---|------|
| Periodic Inspections and Maintenance, General Information | 20.1 |
| Checklists | 20.1 |
| Fluids Added | 20.2 |

Pre- and Post-Trip Checklists

Periodic Inspections and Maintenance, General Information

Regulations in Canada and the U.S. clearly indicate that it is the driver's responsibility to perform an inspection, and ensure the complete road-worthiness of a vehicle, before placing it into service. Commercial vehicles may be subject to inspection by authorized inspectors, and an unsafe vehicle can be taken "out of service" until the driver or owner repairs it.

Use the following checklists to ensure that vehicle components are in good working condition before each trip. Careful inspections eliminate stops later to fix overlooked or forgotten items.

The checklists in this chapter can be copied and kept as a record that the procedures have been completed. For details on how to inspect each item on the checklists, see the corresponding procedure (step number) in [Chapter 21](#).

Checklists

NOTE: Checklists in this chapter correspond with the procedures and steps in [Chapter 21](#), *Pre- and Post-Trip Inspections and Maintenance*. Your vehicle may not be equipped with all components listed below.

Daily Pretrip Inspection Checklists

See the following tables for a list of procedures that should be performed daily, before the first trip. Place a check mark in the complete (**Comp.**) column to indicate a procedure has been performed.

| Inspector | Date |
|-----------|------|
| | |

| Suspension and Slack Adjusters | | Comp. |
|--------------------------------|-----------------------|-------|
| 1 | Suspension components | |
| 2 | Slack adjusters | |

| Wheels and Tires | | Comp. |
|------------------|---------------------------|-------|
| 1 | Wheel covers | |
| 2 | Tire condition | |
| 3 | Tire inflation | |
| 4 | Rims and wheel components | |

| Wheels and Tires | | Comp. |
|------------------|--|-------|
| 5 | Wheel bearing oil seals and lubrication levels | |
| 6 | Mud Flaps | |

| Saddle Tank Areas | | Comp. |
|-------------------|---|-------|
| 1 | Drain air reservoirs (without automatic drain valves) | |
| 2 | Fuel tank(s) secure | |
| 3 | Frame rails and crossmembers | |
| 4 | Visible exhaust components | |

| Engine Compartment | | Comp. |
|--------------------|--------------------------------|-------|
| 1 | Leakage under engine | |
| 2 | Air intake system | |
| 3 | Engine oil level | |
| 4 | Power steering reservoir level | |
| 5 | Engine coolant level | |
| 6 | Visible engine wiring | |
| 7 | Frame rails | |

| Cab | | Comp. |
|-----|---|-------|
| 1 | Reset dash-mounted air intake restriction indicator | |
| 2 | Air-pressure warning systems | |
| 3 | Air governor cut-in and cut-out pressures | |
| 4 | Air pressure build-up time | |
| 5 | Air system leakage | |
| 6 | Air pressure reserve | |
| 7 | Mirrors, windows, windshield | |
| 8 | Horn, windshield wipers, windshield washers | |
| 9 | Heater and defroster | |
| 10 | Interior lights | |
| 11 | Exterior lights | |
| 12 | Seat belts and tether belts | |
| 13 | Fuel level | |
| 14 | Mirror adjustment | |
| 15 | Service brakes | |
| 16 | Backup alarm | |

| Natural Gas Fuel System | | Comp. |
|-------------------------|--|-------|
| 1 | Fuel tanks | |
| 2 | Required decals | |
| 3 | Vent caps | |
| 4 | Plumbing components, fuel fill fitting, fuel lines | |
| 5 | Fuel gauge components, fuel level sender cable, LNG fuel tank pressure | |
| 6 | Coolant hoses | |
| 7 | LNG fuel tank pressure | |

Pre- and Post-Trip Checklists

| Natural Gas Fuel System | | Comp. |
|-------------------------|---------------------------|-------|
| 8 | LNG vaporizer | |
| 9 | Low pressure filter drain | |

Weekly Post-trip Inspection Checklist

See the following table for procedures that should be performed weekly, post-trip. Place a check mark in the complete (**Comp.**) column to indicate a procedure has been performed.

| Inspector | Date |
|-----------|------|
| | |

| Engine Compartment | | Comp. |
|--------------------|------------------------------------|-------|
| 1 | Windshield washer reservoir level | |
| 2 | Air intake restriction indicator | |
| 3 | Water evacuation components | |
| 4 | Automatic transmission fluid level | |
| 5 | Water in fuel/water separator | |
| 6 | Steering components | |
| 7 | Serpentine drive belts | |

Monthly Post-trip Inspection Checklists

See the following tables for procedures that should be performed monthly, post-trip. Place a check mark in the complete (**Comp.**) column to indicate a procedure has been performed.

| Inspector | Date |
|-----------|------|
| | |

| Brake Components | | Comp. |
|------------------|-------------------------------|-------|
| 1 | Brake system components | |
| 2 | Brake chambers | |
| 3 | Air brake lines | |
| 4 | Flex air hoses | |
| 5 | Brake linings and brake drums | |
| 6 | Brake lining thickness | |

| Saddle Tank Areas | | Comp. |
|-------------------|--|-------|
| 1 | Drain air reservoirs (with automatic drain valves) | |
| 2 | Batteries (location may vary) | |
| 3 | Aerodynamic components | |

| Engine Compartment | | Comp. |
|--------------------|----------------------------|-------|
| 1 | Hood and bumper | |
| 2 | Hydraulic clutch reservoir | |
| 3 | Radiator and heater hoses | |
| 4 | Steering wheel play | |

Fluids Added

Use the following table to note any fluids that were added during the inspection and maintenance procedures.

| Fluids Added During Inspection | |
|--|--------------|
| Fluid | Amount Added |
| Wheel Bearing Lubricant | |
| Engine Oil | |
| Power Steering Fluid | |
| Engine Coolant | |
| Windshield Washer Fluid | |
| Automatic Transmission Fluid | |
| Hydraulic Clutch Fluid (DOT 4 brake fluid) | |

21

Pre- and Post-Trip Inspections and Maintenance

| | |
|---|-------|
| Daily Pretrip Inspection and Maintenance | 21.1 |
| Weekly Post-Trip Inspections and Maintenance | 21.10 |
| Monthly Post-Trip Inspections and Maintenance | 21.13 |

Pre- and Post-Trip Inspections and Maintenance

Daily Pretrip Inspection and Maintenance

Complete the following inspection and maintenance procedures to ensure that vehicle components are in good working condition before each trip. A driver who is familiar with the vehicle and drives it regularly can perform the daily inspections, then add the weekly and monthly post-trip inspections as scheduled.

If the driver does not operate the vehicle on a consistent basis, all daily, weekly, and monthly inspection and maintenance procedures should be performed before the trip.

IMPORTANT: The pre- and post-trip checklists, inspections, and maintenance procedures detailed in this chapter are **not all-inclusive**. Refer to other component and body manufacturers' instructions for specific inspection and maintenance instructions, as well as local, state, and federal guidelines.

NOTE: If any system or component does not pass this inspection, it must be corrected before operating the vehicle. Whenever equipment requires adjustment, replacement, and/or repair, see the *Cascadia Workshop Manual* for procedures and specifications.

Suspension and Slack Adjuster Inspection

Walk around the vehicle and visually inspect suspension and slack adjuster components.

1. Inspect the following suspension components for signs of structural damage, cracks, or wear.
 - springs
 - spring hangers
 - shocks
 - suspension arms
 - suspension brackets
 - axle seats
 - bushings
2. Inspect slack adjusters for signs of damage. See [Fig. 21.1](#), [Fig. 21.2](#), or [Fig. 21.3](#).

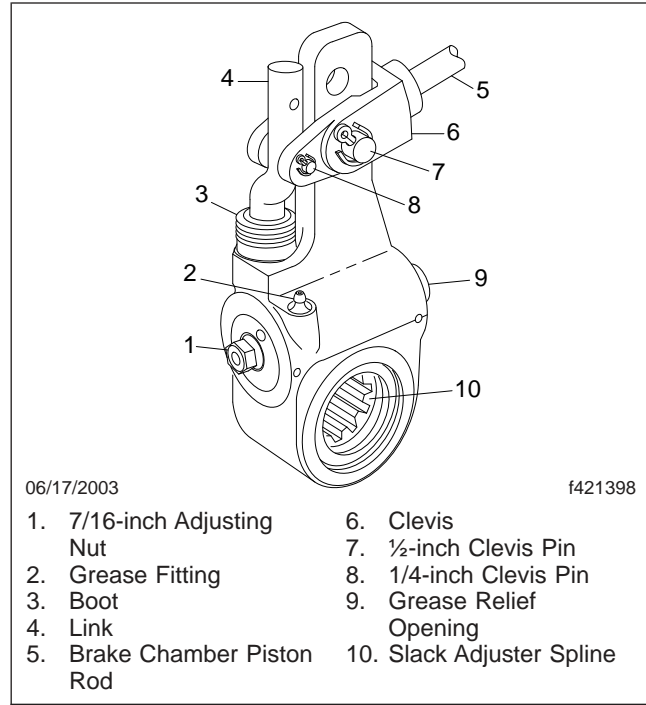

Fig. 21.1, Gunite Automatic Slack Adjuster

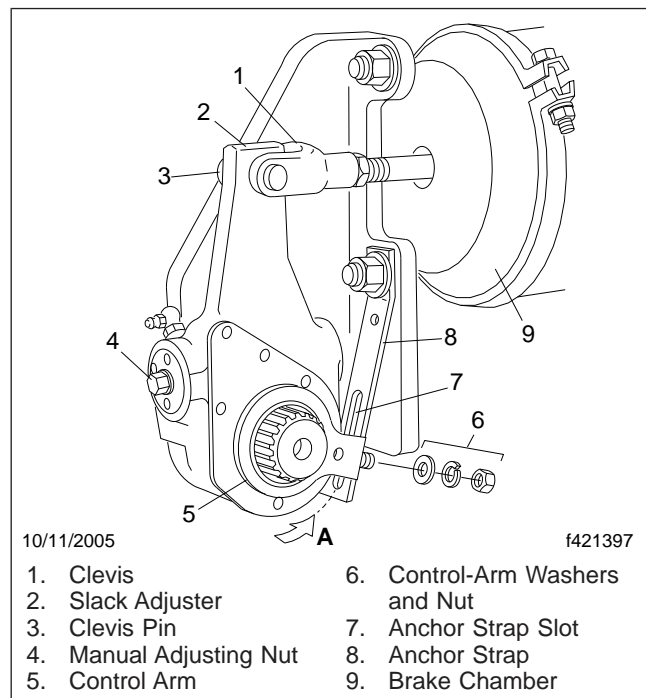

Fig. 21.2, Haldex Automatic Slack Adjuster

Pre- and Post-Trip Inspections and Maintenance

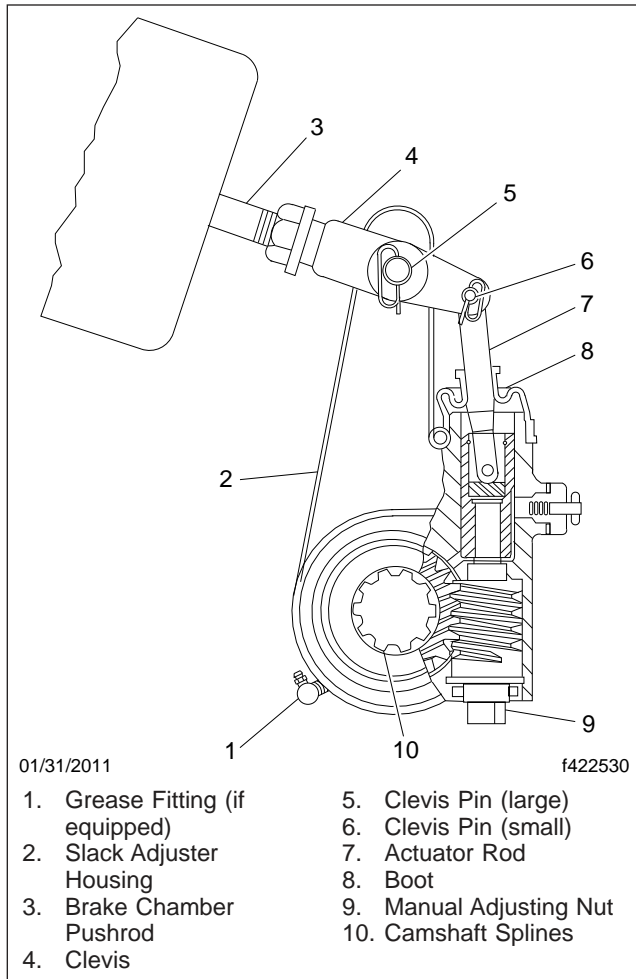

Fig. 21.3, Meritor Automatic Slack Adjuster

- Inspect slack adjuster boots, if equipped, for cuts or tears.
- Inspect anchor straps, if equipped, for damage.
- Look for worn clevis pins on brake chamber pushrods.
- Look for missing or damaged cotter pins on the clevis pins.
- Ensure chamber piston rods are in line with the slack adjusters.

Wheel and Tire Inspection

Walk around the vehicle and visually inspect each wheel and tire assembly.

IMPORTANT: Wheel covers decrease drag force as a vehicle moves, thereby improving fuel efficiency. If replacement of a wheel cover is necessary, the replacement cover must meet or exceed the drag reduction performance of the originally installed cover in order to maintain compliance with greenhouse gas and full efficiency regulations (GHG14).

1. If the vehicle was originally equipped with wheel covers, ensure all wheel covers are present. Inspect wheel covers for damage or wear. Remove wheel covers from rear drive wheels, if equipped, prior to inspecting the tires and wheel components.

NOTE: During wheel cover installation, ensure the V-notch in the liner inner retaining ring is centered on the valve stem. The inner and outer retaining rings should be uniformly aligned to each other and to the wheel rim. The outer retaining ring of the liner is equipped with two canvas flaps. When installing the face cover, make sure the cover retaining ring is inserted between the two canvas flaps on the liner outer retaining ring so that the Velcro strips line up between the face cover and the liner. Make certain the detachable view cover is centered on the face cover, and the Velcro strips are pressed firmly in place.

2. Inspect each tire for the following:

- valve stem caps on every tire, screwed on finger-tight
- bulges, cracks, cuts, and penetrations
- oil contamination (petroleum derivatives will soften the rubber and destroy the tire)
- tread depth—if tread is less than 4/32 inch (3 mm) on any front tire, or less than 2/32 inch (1.5 mm) on any rear tire, replace the tire
- debris lodged between dual tire sets

IMPORTANT: Low-rolling resistance (LRR) tires minimize wasted energy as a tire rolls, thereby decreasing rolling effort and improving fuel efficiency. If tire replacement is necessary, replacement tires must meet or exceed the rolling resistance of the originally installed tires in order to

Pre- and Post-Trip Inspections and Maintenance

maintain compliance with greenhouse gas and full efficiency regulations (GHG14).

Contact your tire manufacturer/supplier to determine the rolling resistance of the originally installed tires. Visit www.epa.gov/smartway for additional information and resources.

3. Check tire inflation.

For inflation pressures and maximum loads, see the tire manufacturer's guidelines. Inflate the tires to the applicable pressures if needed.

If a tire has been run flat or under-inflated, check the wheel and tire for damage before adding air.

Keep compressed air reservoirs and lines dry during tire inflation. Use well-maintained inline moisture traps and service them regularly.

WARNING

Do not operate the vehicle with underinflated or overinflated tires. Incorrect inflation can stress the tires and make the tires and rims more susceptible to damage, possibly leading to rim or tire failure and loss of vehicle control, resulting in serious personal injury or death.

NOTICE

A weekly pressure loss of 4 psi (28 kPa) or more in a tire may indicate damage. The tire should be inspected and, if necessary, repaired or replaced by a qualified tire service facility.

IMPORTANT: The load and cold inflation pressure must not exceed the rim or wheel manufacturer's recommendations, even though the tire may be approved for a higher load inflation. Consult the rim or wheel manufacturer for the correct tire inflation pressure for the vehicle load.

4. Examine each rim and wheel component.

- 4.1 Remove all dirt and debris from the assembly. Rust streaks or metal build-up around stud holes, or out-of-round or worn stud holes, may be caused by loose wheel nuts.

WARNING

Have any worn or damaged wheel components replaced by a qualified person using the wheel manufacturer's instructions and the wheel industry's standard safety precautions and equipment. Otherwise a vehicle or workshop accident could occur, possibly resulting in serious personal injury or death.

- 4.2 Inspect for broken, cracked, badly worn, bent, rusty, or sprung rings and rims.

NOTICE

Use the recommended torque values and follow the proper tightening sequence. Insufficient wheel nut torque can cause wheel shimmy, resulting in wheel damage, stud breakage, and extreme tire tread wear. Excessive wheel nut torque can break studs, damage threads, and crack discs in the stud hole area.

- 4.3 Make sure all wheel nuts are tightened. If tightening is necessary, use the tightening pattern in Fig. 21.4 to initially tighten the flange nuts to 50 to 100 lbf·ft (68 to 136 N·m). Then tighten the flange nuts to 450 to 500 lbf·ft (610 to 678 N·m).

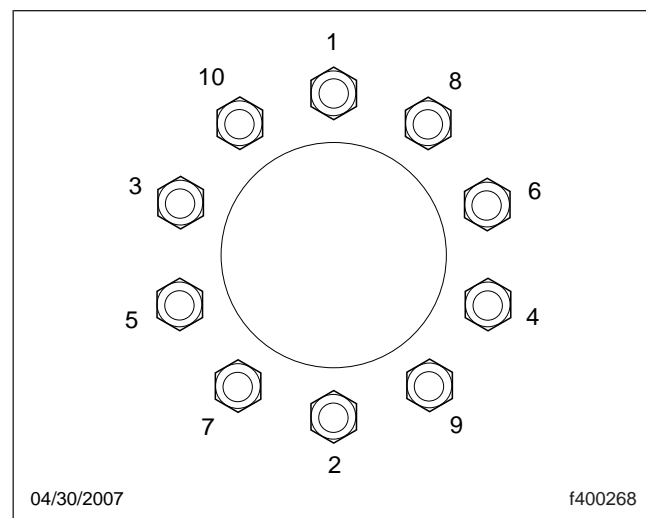

Fig. 21.4, Tightening Pattern, 10-Hole Wheels

5. Inspect the outboard side of all wheel hubs and the hub oil seal area on the inboard side of each wheel for signs of oil leakage. If any oil is found

Pre- and Post-Trip Inspections and Maintenance

on wheel and tire or brake components, remove the vehicle from service until the leak has been fixed.

If needed, fill the hubs to the level indicated on the hub cap. See **Group 35** of the *Cascadia Maintenance Manual* for recommended lubricants.

6. Check that mud flaps are undamaged and hang 10 inches (25.4 cm) or less from the ground.

Saddle Tank Areas Inspection

WARNING

When draining the air reservoir, do not look into the air jets or direct them toward anyone. Dirt or sludge particles may be in the airstream and could cause injury.

NOTICE

If the water drained from the air reservoirs is cloudy or oily, it may indicate a problem with the compressor. If oil is allowed to contaminate the air dryer, it will not remove the water from the air brake system, which could adversely affect braking.

1. Drain the brake system air reservoirs (reservoirs without automatic drain valves only).

WARNING

Never operate the engine with the fuel tank shut-off valves partially closed. This could damage the fuel pump, causing sudden loss of engine power, possibly resulting in serious personal injury due to reduced vehicle control.

2. Ensure fuel tanks are secured to their mounting brackets and that the mounting brackets are secured to the frame.
If equipped with fuel tank shutoff valves, be sure the valves are fully open.
3. Inspect visible frame rails for missing bolts, shiny areas, or rust streaks. Check all visible cross-members for damage or signs of looseness.
4. Inspect visible components of the exhaust system to ensure connections are tight.

Inspect upstream of the aftertreatment device (ATD), if equipped, for cracking or signs of leaks, such as soot trails. Inspect downstream of the ATD for signs of exhaust leaks, such as blistering or warping of nearby components.

Engine Compartment Inspection

1. Check the ground underneath the engine for fuel, oil, or coolant leaks.
2. Inspect the air intake system for leaks or damage.

NOTICE

Failure to maintain a sealed air intake system could allow the entry of dirt and contaminants into the engine. This could adversely affect engine performance and result in engine damage.

- 2.1 Push the reset button on the air intake restriction indicator located on the air cleaner, if equipped.
- 2.2 Check the air intake duct from the air cleaner to the engine intake. Make sure the duct components are secure and airtight.
3. Check the engine oil level.

NOTICE

Operating the engine with the oil level below the minimum fill (or "add") mark or above the maximum fill (or "full") mark could result in engine damage.

- 3.1 Check the oil level with the vehicle parked on a level surface. See the engine manufacturer's guidelines for engine shutdown time requirements prior to checking the oil level.

IMPORTANT: On engines that comply with EPA07 or newer regulations, use CJ-4 engine oil with less than 1% sulfated ash. Failure to use CJ-4 oil may void the warranty on emission aftertreatment components.

- 3.2 If the oil level is at or below the minimum fill (or "add") mark on the dipstick, add enough oil to maintain the level between

Pre- and Post-Trip Inspections and Maintenance

the minimum and maximum fill marks. See the engine operation manual for recommended lubricants.

For natural gas vehicles, use only Exxon Busgard® Geo 15W-40 natural gas engine oil.

4. Check the power steering reservoir fluid level.

The power steering fluid level should be between the MIN COLD mark and the middle mark just above it. See [Fig. 21.5](#). If needed, fill the reservoir with automatic transmission fluid that meets Dexron III or TES-389 specifications.

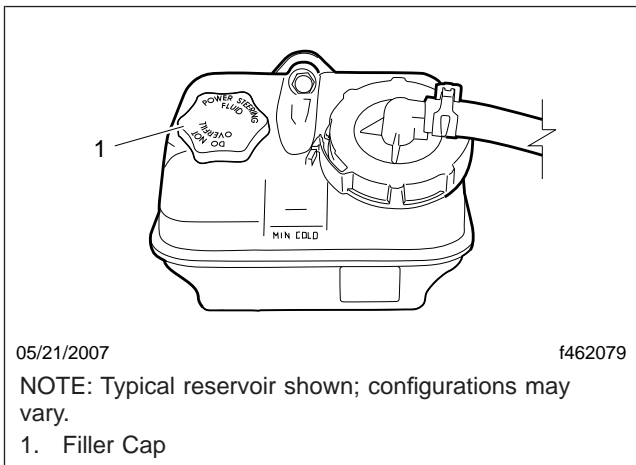

Fig. 21.5, Power Steering Fluid Reservoir

NOTICE

Low coolant could result in engine overheating, which could cause engine damage.

IMPORTANT: The surge tank must be cool to check the coolant level.

5. Check the engine coolant level in the radiator surge tank. See [Fig. 21.6](#).

NOTICE

Coolant must be filled to the COLD MAX line of the surge tank. Low coolant could result in engine overheating, which could cause engine damage.

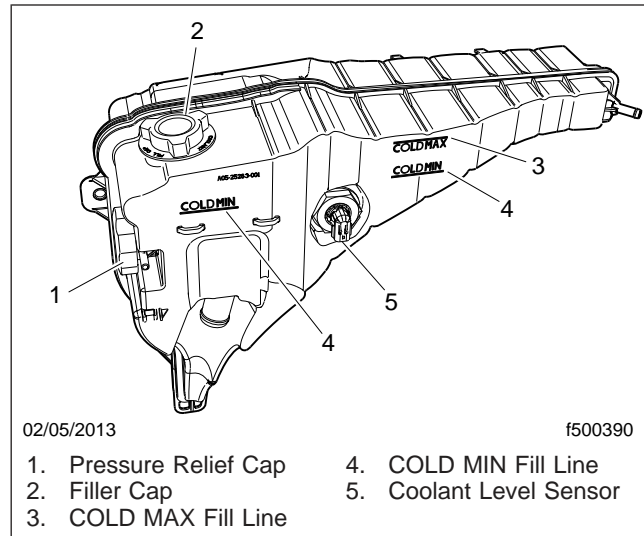

Fig. 21.6, Coolant Surge Tank

- 5.1 If the coolant is low, fill the surge tank to the MAX line with a 50/50 mixture of water and the type of antifreeze currently installed in your vehicle.

For natural gas vehicles, use only Fleet-guard ES Compleat™ EG Premix 50/50 engine coolant.

- 5.2 If the surge tank was empty, start the engine after refilling and check the level again when the engine is at operating temperature.

6. Inspect visible engine wiring for damage or looseness. Check for loose wiring, chafed insulation, and damaged or loose hold-down clamps.
7. Inspect visible frame rails for missing bolts, shiny areas, or rust streaks.

Cab Inspection

1. Push the reset button on the dash-mounted air intake restriction indicator, if equipped.
2. With the ignition switch in the OFF position, check the air-pressure warning system.
- 2.1 If not previously drained, drain the air reservoirs using moderate brake applications until pressure in both reservoirs is less than 70 psi (483 kPa).

Pre- and Post-Trip Inspections and Maintenance

- 2.2 Turn the ignition to the ON position. The ICU will complete a full gauge sweep and bulb check, and an audible warning will sound. Ensure the low air pressure lamp (BRAKE AIR) remains illuminated and an audible warning continues to sound after the gauge sweep is complete.
3. Check air governor cut-in and cut-out pressures.
 - 3.1 Start the engine and ensure the BRAKE AIR lamp goes out and the buzzer silences when pressure reaches approximately 70 psi (483 kPa) in both air reservoirs.

The air governor should cut out at approximately 120 psi (827 kPa). For vehicles with an optional dryer reservoir module (DRM), the cut-out pressure is approximately 130 psi (896 kPa).
 - 3.2 With the engine idling, apply the brake pedal several times. The air governor should cut in when pressure in the primary air reservoir (top air gauge) reaches approximately 100 psi (689 kPa).
4. Check air pressure build-up time.
 - 4.1 With the air system fully charged, make one full brake application and note the air pressure reading on the primary air gauge.
 - 4.2 Further reduce air pressure using moderate brake applications, then run the engine at governed rpm.
 - 4.3 Note the time that the pressure reaches the previously noted reading on the primary air gauge, then note the time that the air pressure reaches cut-out pressure.
 - 4.4 If it takes longer than 30 seconds to reach cut-out pressure after the primary air gauge passes the previously noted pressure (noted after one full brake application), eliminate any leaks or replace the air compressor before operating the vehicle.
5. Check air leakage in the system.
 - 5.1 With the parking brake applied, the transmission out of gear, and the air system fully charged, release the service brakes and shut down the engine.

- 5.2 Wait one minute and note the air pressure drop in psi (kPa) per minute from the primary air reservoir.

If the pressure drop exceeds the limits shown in **Table 21.1**, eliminate any leaks before operating the vehicle.

6. Check the air pressure reserve.

With the engine still off, make one full brake application and observe the pressure drop on the primary air gauge. If pressure drops more than 25 psi (172 kPa), eliminate any leaks before operating the vehicle.

| Maximum Allowable Air Leakage | | |
|-----------------------------------|--|---------|
| Description | Pressure Drop: psi (kPa) Per Minute | |
| | Released | Applied |
| Truck or Tractor Only | 2 (14) | 3 (21) |
| Truck or Tractor w/Single Trailer | 3 (21) | 4 (28) |
| Truck or Tractor w/Two Trailers | 5 (35) | 6 (42) |

Table 21.1, Maximum Allowable Air Leakage

WARNING

When cleaning windshields and windows, always stand on the ground or on a secure ladder or platform. Use a long-handled window cleaner. Do not use the cab steps, tires, fenders, fuel tanks, engine, or under-hood components to access the windshield or windows. Doing so could cause a fall and result in an injury.

7. Inspect the mirrors, window glass, and windshield for cracks or other damage.
8. Ensure that the horn, windshield wipers, and windshield washers are operating properly. These devices must be in good working order for safe vehicle operation.
9. Ensure the heater and defroster are operating properly.
10. Check the operation of all interior lights.
 - 10.1 Turn on the headlights and leave them on. Ensure all equipped gauge bulbs illuminate in the dash message center.
 - 10.2 Ensure all equipped driver control switches illuminate.

Pre- and Post-Trip Inspections and Maintenance

- 10.3 Ensure both turn signal indicator bulbs illuminate in the dash message center when the turn signal switch is activated.
11. Check the operation of all exterior lights. See **Fig. 21.7**.
 - 11.1 Activate the high-beam headlights and hazard warning lights.
 - 11.2 Exit the cab and check that all exterior lights and reflectors are clean and intact.
 - 11.3 Check that the brake lights, taillights, headlights, turn signals, marker lights, identification lights, and clearance lights are working properly.
12. Inspect the seat belts and tether belts.

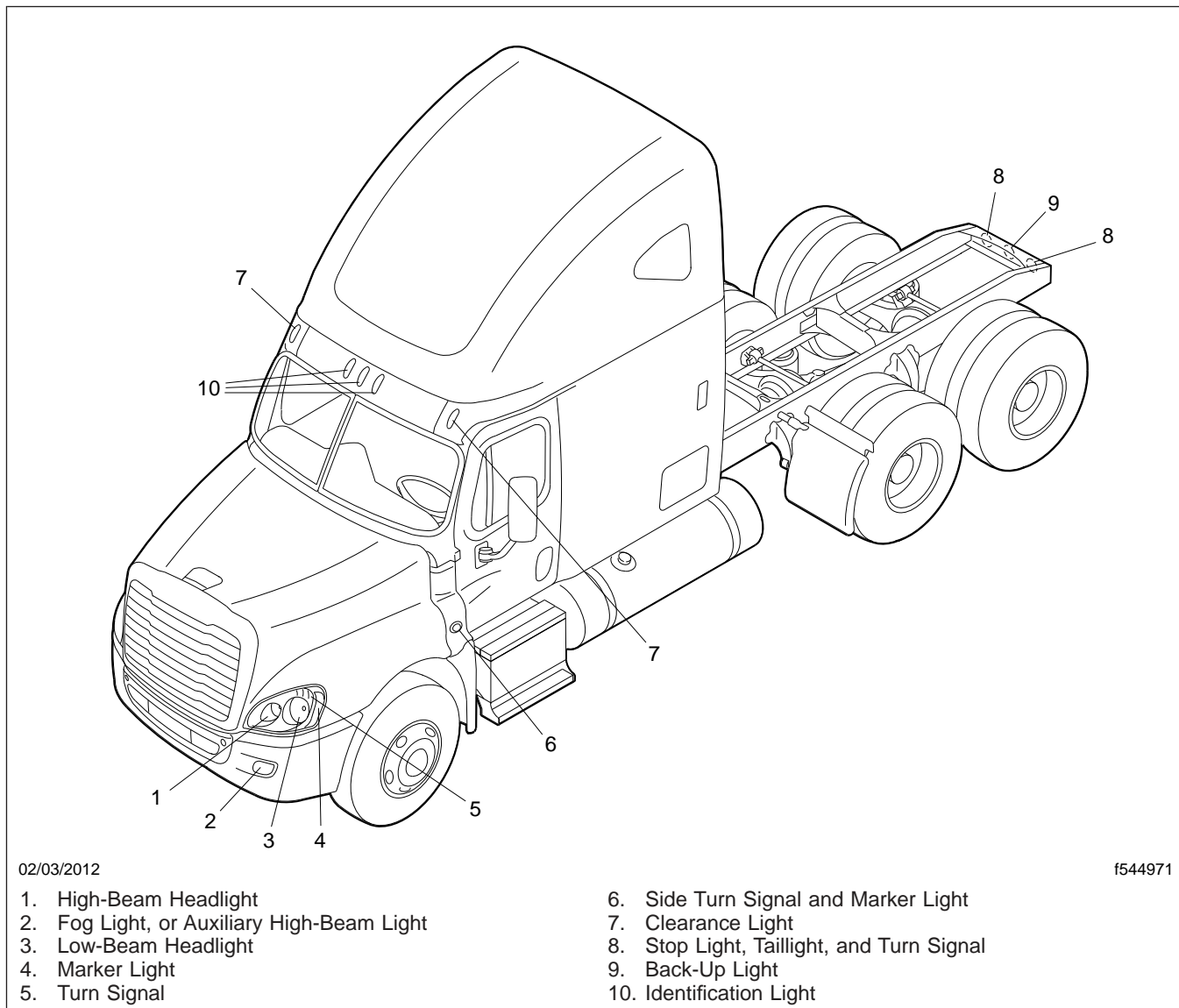

Fig. 21.7, Exterior Lights

Pre- and Post-Trip Inspections and Maintenance

WARNING

Inspect and maintain seat belts. When any part of a seat belt system needs replacement, the entire seat belt must be replaced, both retractor and buckle side. Any time a vehicle is involved in an accident, and the seat belt system was in use, the entire vehicle seat belt system must be replaced before operating the vehicle. Do not attempt to modify the seat belt system; doing so could change the effectiveness of the system. Failure to replace worn or damaged seat belts, or making any modifications to the system, may result in personal injury or death.

- 12.1 Check the web for fraying, cuts, extreme dirt and dust, or for severe fading from exposure to sunlight, especially near the buckle latch plate and in the D-loop guide area.
- 12.2 Check operation of the buckle, latch, Komfort Latch or Sliding Komfort Latch (if equipped), web retractor, and upper seat belt mount on the door pillar. Check all visible components for wear or damage.
- 12.3 Check the seat belt and tether belt connection points and tighten any that are loose.

WARNING

Never fill fuel tanks to more than 95 percent of their liquid capacity. This could make them more likely to rupture from impact, possibly causing fire and resulting in serious personal injury or death by burning.

Do not mix gasoline or alcohol with diesel fuel. This mixture could cause an explosion, possibly resulting in serious personal injury or death. Do not fill the fuel tanks in the presence of sparks, open flames, or intense heat. These could ignite the fuel, possibly causing severe burns.

IMPORTANT: On engines that comply with EPA07 or newer regulations, use ultralow-sulfur diesel (ULSD) with 15 ppm sulfur content or less. Failure to use ULSD fuel may void the warranty on emission components.

13. Check the fuel level in the fuel tank(s). To keep condensation to a minimum, fuel tanks should be filled at the end of each day.
14. Adjust the rearview and down view mirrors as necessary.
15. Test the service brakes.
 - 15.1 With the engine running and air system fully charged, set the parking brake.
 - 15.2 Put the vehicle in the lowest gear and gently attempt to move it forward. The vehicle should not move.

If the vehicle moves, the parking brakes are not operating correctly and must be repaired before the vehicle is operated.
16. Test the backup alarm.
 - 16.1 Release the parking brake and put the transmission in reverse.
 - 16.2 Move the vehicle slightly backward to ensure that the backup alarm is operating correctly.

Natural Gas Fuel System Inspection

WARNING

As with all pressure vessels, CNG/LNG storage and fuel delivery systems are inherently dangerous and should be treated as such. Beyond the visual inspections listed below, all maintenance and repairs to compressed natural gas (CNG) or liquified natural gas (LNG) systems should be performed by trained personnel. Individuals who are not trained in all aspects concerning CNG/LNG fuel delivery systems are not permitted to service, maintain, test, or inspect a system in any way. Failure to comply with safety regulations may lead to fire or explosion, resulting in property damage, personal injury, or death.

1. Inspect fuel tanks for dents, scratches, gouges, or other signs of damage. Inspect the fuel lines and connections for leaks.

Check that the fuel tanks are securely mounted. Look for signs of abrasion between components.

CNG Fuel System: Ensure that the CNG fuel cylinder storage box is secured to the frame. Inspect for signs of looseness.

Pre- and Post-Trip Inspections and Maintenance

(LNG Fuel System: Ensure that the LNG fuel tank is secured to the mounting brackets and that the mounting brackets are secured to the frame. Ensure all rubber isolator straps are secure around the LNG fuel tank.

2. Check for the presence of all required decals present in the following locations:
 - Gas detection system overhead console;
 - Above the door handle on both doors;
 - Left front bumper;
 - End-of-frame crossmember;
 - LNG fuel tank fill port (maximum psi), if equipped.
3. Check for the presence of vent caps on pressure relief valves and devices. See [Fig. 21.8](#). If any caps are missing, have the fuel system inspected by a qualified technician.

CNG Fuel System: Each fuel cylinder should have two caps (one on each end), which are visible on the back of the CNG fuel cylinder storage box. One additional cap is located on the pressure relief valve on the inboard side of the CNG fuel box, next to the fuel outlet line. If equipped with saddle tanks, there are also two vent tubes with caps between the back of the cab and the back-of-cab fuel tanks.

LNG Fuel System: A red cap should be present on the secondary relief valve. See [Fig. 21.9](#).

4. Inspect all plumbing components, including the fuel shutoff valve(s), primary and secondary relief valves, and the LNG vapor shutoff and excess flow valves, if equipped, for signs of damage or leaks. See [Fig. 21.9](#) or [Fig. 21.10](#).

Inspect the fuel fill fitting for signs of damage or leaks.

Inspect all lines for signs of leaks or damage, and check all threaded connections.

5. Inspect all fuel gauge components for signs of leaks or damage. Inspect the fuel level sender cable and wiring.
6. Inspect all coolant hoses for signs of chafing, kinks, or leaks. The CNG fuel system utilizes coolant hoses between the engine and the pressure regulator inside the fuel panel. The LNG



Fig. 21.8, CNG Vent Line Caps

fuel system utilizes coolant hoses between the engine and the vaporizer.

7. If equipped with an LNG fuel system, check the fuel tank pressure gauge to ensure that pressure is within the normal range of 120 to 150 psi (827 to 1034 kPa). If tank pressure exceeds 230 psi (1586 kPa) and the pressure relief valve does not open automatically, vent the tank immediately.
8. Inspect the LNG vaporizer for signs of damage or leaks. See [Fig. 21.9](#). Inspect the vaporizer mounting brackets for signs of looseness.
9. On CNG systems, check the low pressure fuel filter(s) at the engine for contamination.
 - 9.1 Turn the engine off and remove the key from the ignition.
 - 9.2 Slowly open the drain petcock and drain any fluid into an appropriate container.
10. When fluid stops, close the drain petcock.
11. Examine the fluid.

Pre- and Post-Trip Inspections and Maintenance

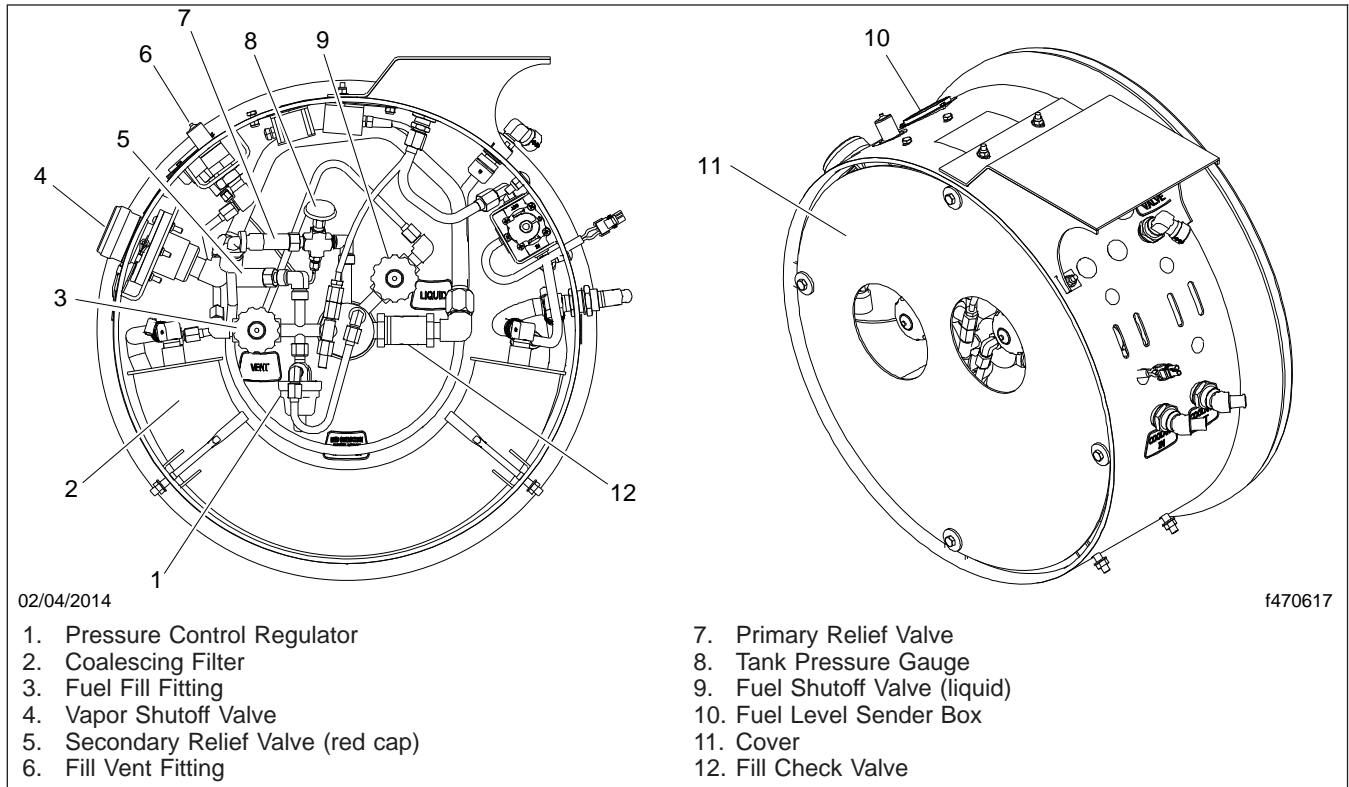

Fig. 21.9, LNG Tank Plumbing Components

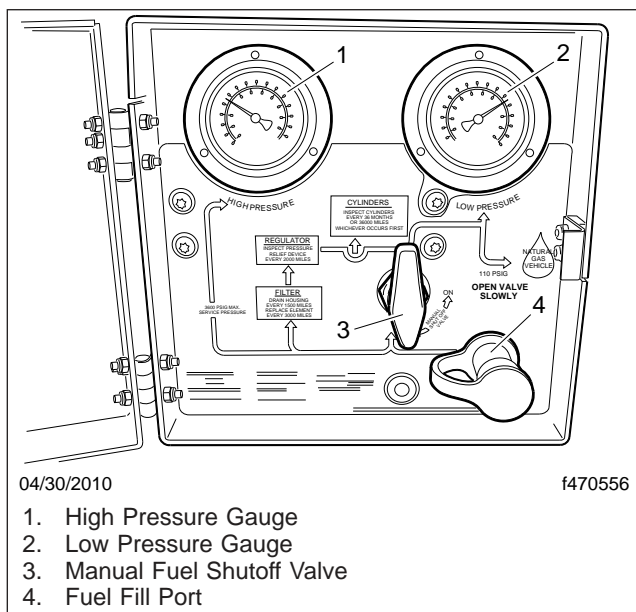

Fig. 21.10, CNG Fuel Panel

If more than approximately one ounce of oil or other contaminants is found, have the system checked at a qualified service center.

Weekly Post-Trip Inspections and Maintenance

Engine Compartment Inspection

WARNING

Washer fluids may be flammable and poisonous. Do not expose washer fluid to an open flame or any burning material, such as a cigarette. Always comply with the washer fluid manufacturer's recommended safety precautions.

1. Check the windshield washer reservoir fluid level. The reservoir is usually located near the right-hand frame rail. See [Fig. 21.11](#).

Pre- and Post-Trip Inspections and Maintenance

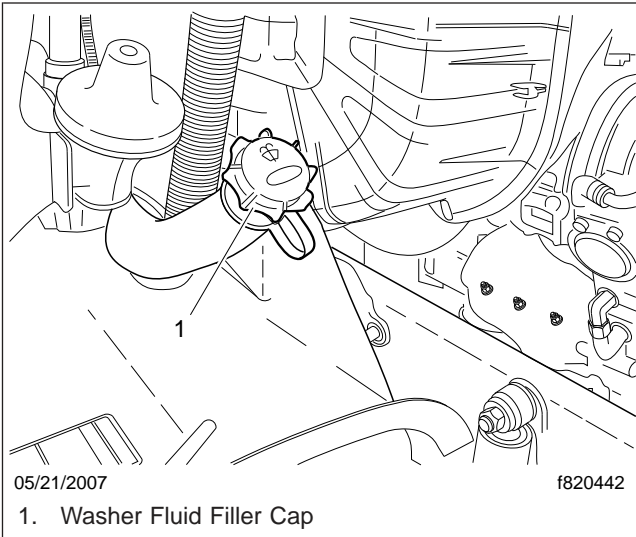

Fig. 21.11, Windshield Washer Reservoir

2. After resetting the air intake restriction indicator during the daily pretrip inspection, check the indicator again with the engine off.
 - 2.1 Check an indicator with graduations to see if air restriction exceeds the value shown in **Table 21.2**.
Check a go/no-go indicator without graduations to see if the colored bar shows through the clear window.

| Air Intake Maximum Restriction Values (inH ₂ O) | | |
|--|-------------------|-------------------------|
| Engine Make | Pre-EPA07 Engines | EPA07 and Newer Engines |
| Cummins | 25 | 25 |
| Detroit | 20 | 22 |
| Mercedes-Benz | 22 | 22 |

Table 21.2, Air Intake Maximum Restriction Values

- 2.2 If air restriction exceeds the maximum allowable value, operate the vehicle for one more day, making sure not to run the engine over rated rpm. Refer to the engine operation manual for more information on rated rpm for your engine.
- 2.3 If air restriction exceeds the maximum value again, replace the air cleaner. For instructions, refer to **Group 09** of the *Cascadia Workshop Manual*.

3. Inspect water evacuation components.
 - 3.1 Inspect the vacuator valve(s) installed on the hood interior and air cleaner. Make sure the lips of each valve are undamaged and pliable, free of debris, and remain closed during inspection. See **Fig. 21.12** and **Fig. 21.13**.
 - 3.2 Inspect the rain tray installed at the base of the windshield. Ensure that the seal on the forward edge of the rain tray is in good condition.
 - 3.3 Inspect the drain hoses installed on the rain tray. Both hoses should be securely attached to the rain tray and direct water down the aft side of the front fenders. See **Fig. 21.14**.
4. If the vehicle is equipped with an Allison automatic transmission, check the automatic transmission fluid level.
5. Check for water in the fuel/water separator, if equipped.

IMPORTANT: When draining fluid from a fuel/water separator, drain the fluid into an appropriate container and dispose of it properly. Many jurisdictions now issue fines for draining fuel/water separators onto the ground.

- 5.1 Place a suitable container under the fuel/water separator.

NOTE: A hose may be used to direct water into the container. Use a hose with a ½-inch pipe thread on DAVCO models.

- 5.2 If the engine is equipped with a built-in water separator, loosen the drain valve, and allow the water to run out. Close the drain valve, taking care not to overtighten it.
- 5.3 *Alliance/Racor Models:* Turn the drain plug counterclockwise to open it. See **Fig. 21.15**.
DAVCO Models: Remove the vent cap and open the drain. See **Fig. 21.16**.
- 5.4 Stop draining fluid when fuel begins to drain out.

Pre- and Post-Trip Inspections and Maintenance

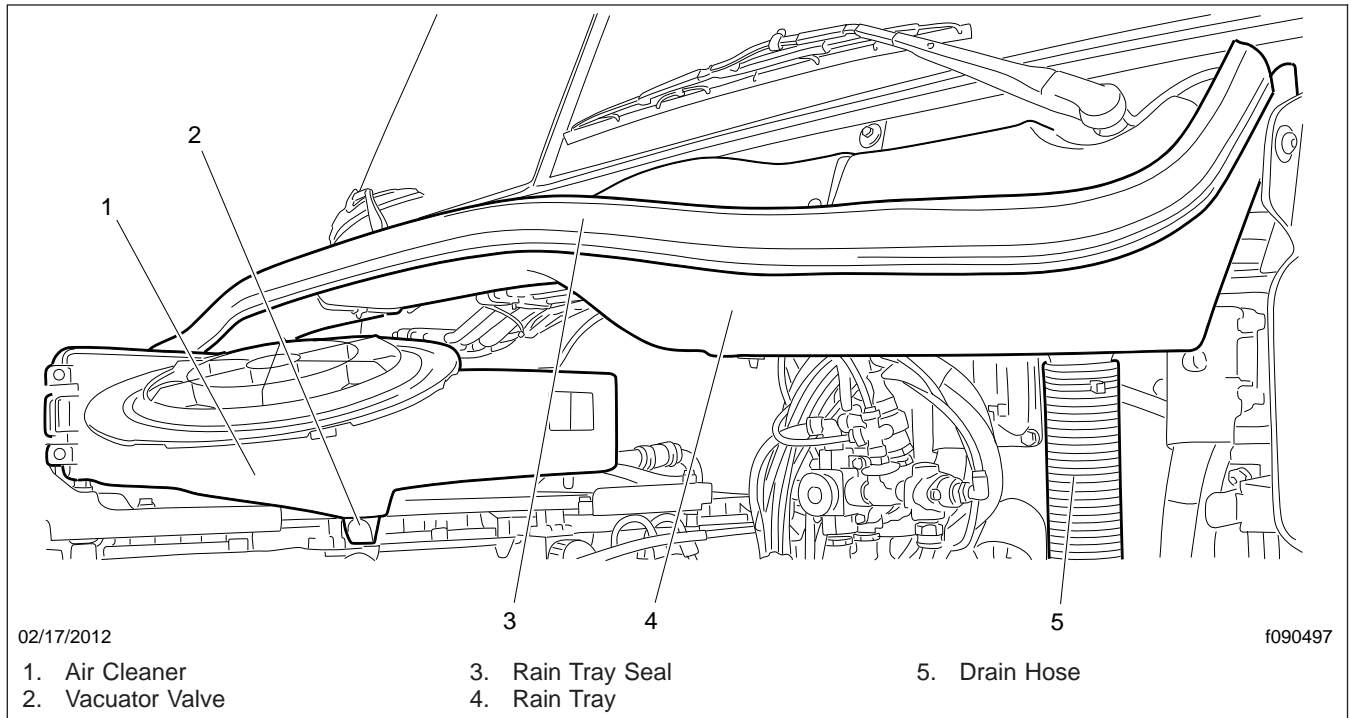

Fig. 21.12, Rain Tray Assembly

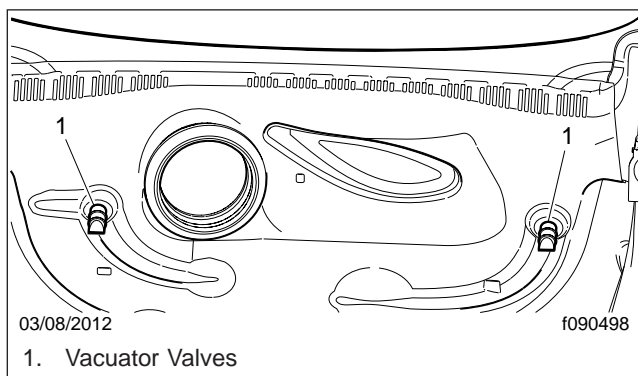

Fig. 21.13, Hood Interior

Alliance/Racor Models: turn the drain plug clockwise to close it.

DAVCO Models: close the drain valve. Install and hand-tighten the vent cap.

6. Inspect the steering components.

- 6.1 Inspect tie rods, steering arms, and the drag link for signs of looseness (i.e., shiny spots or rust tracks). See [Fig. 21.17](#) for a rack and pinion steering gear; see [Fig. 21.18](#) for an integral steering gear.
- 6.2 Check the steering gear mounting bolts and pitman arm nut, if equipped, for signs of looseness.
- 6.3 Check the drag link nuts for missing cotter pins.
- 6.4 Inspect the steering intermediate shaft and end yokes for excessive looseness or other damage.

NOTICE

Do not drive with a drive belt that is visibly worn or damaged. If it fails, the lack of coolant flow could rapidly cause damage to engine components.

7. Inspect the serpentine drive belts for signs of glazing, frayed edges, breaks, cracks, or oil contamination.

Pre- and Post-Trip Inspections and Maintenance

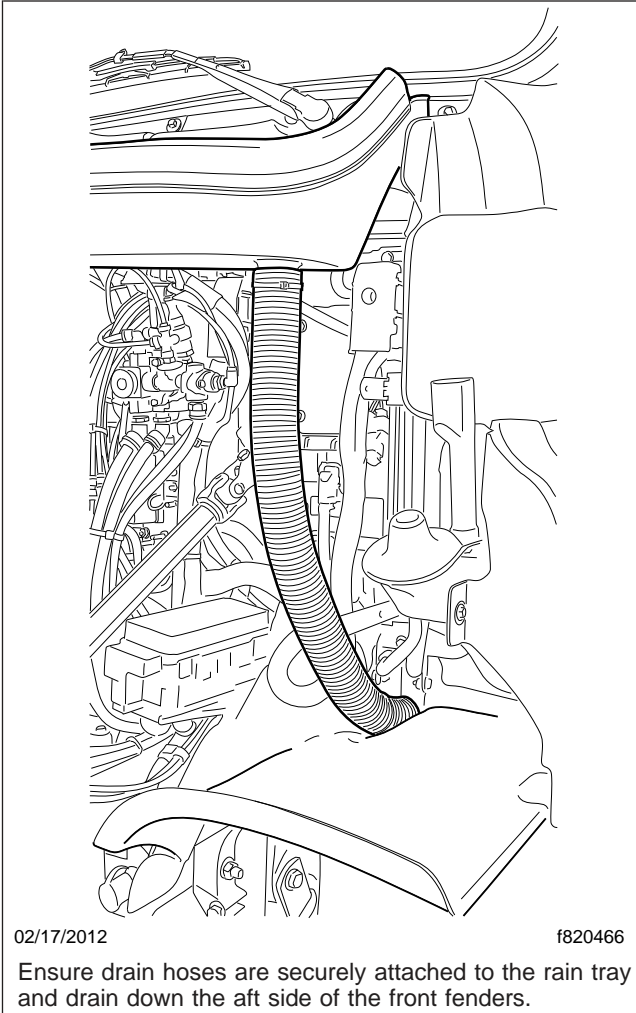

Fig. 21.14, Drain Hose

Monthly Post-Trip Inspections and Maintenance

Brake Component Inspection

Walk around the vehicle and inspect brake system components for visible damage.

1. Inspect all visible brake system components for missing fasteners or signs of looseness, such as rust tracks.

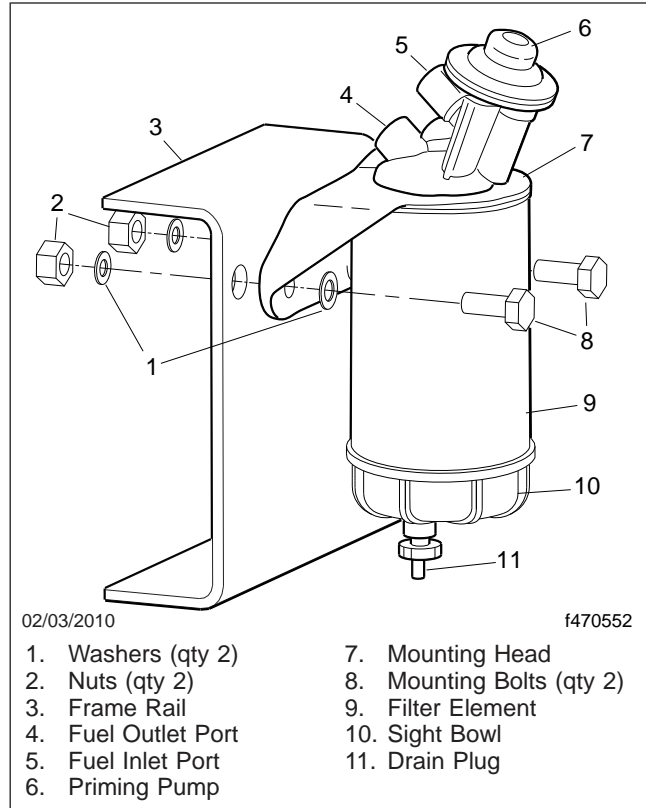

Fig. 21.15, Alliance Fuel/Water Separator Assembly and Installation

NOTICE

If the external breather tube or breather cap is missing or incorrectly installed, road dirt and debris can adversely affect the operation of the brake chamber. Once inside of the chamber, dirt and debris can cause the internal parts of the chamber to deteriorate faster.

2. Inspect the exterior surfaces of brake chambers for damage. Make sure that breather holes are open and free of debris.

NOTE: Do not route air brake lines on top of anything likely to be stepped on.

3. Inspect air brake lines for dents, swelling, kinks, twisting, abrasion, and damage, especially near moving parts.
4. Inspect flex air lines for deterioration or signs of abrasion.

Pre- and Post-Trip Inspections and Maintenance

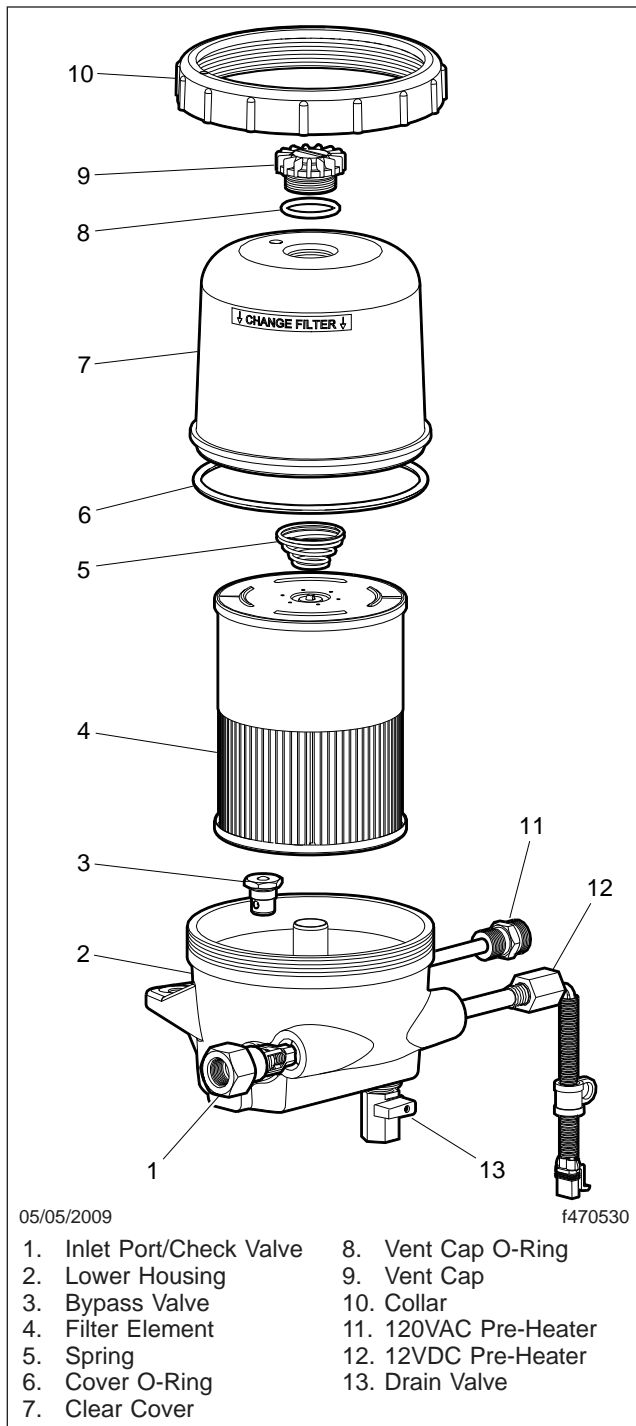

Fig. 21.16, DAVCO Fuel/Water Separator (Fuel Pro 482 shown)

5. Inspect for cracked, worn, or oil-contaminated brake linings and brake drums (or rotors).
6. Check the thickness of the brake linings. Replace brake linings on all brake assemblies on the axle if any brake linings are worn to less than approximately 1/4 inch (6.4 mm) at the thinnest point.

Saddle Tank Areas Inspection

WARNING

When draining the air reservoir, do not look into the air jets or direct them toward anyone. Dirt or sludge particles may be in the airstream and could cause injury.

NOTICE

If the water drained from the air reservoirs is cloudy or oily, it may indicate a problem with the compressor. If oil is allowed to contaminate the air dryer, it will not remove the water from the air brake system, which could adversely affect braking.

1. Drain the brake system air reservoirs (reservoirs with automatic drain valves only).

NOTE: Battery locations vary between vehicles.

2. Inspect the batteries.

WARNING

Battery posts, terminals, and related accessories contain lead and lead compounds, chemicals known to the State of California to cause cancer and reproductive harm. To prevent possible personal injury, always wash your hands after handling battery parts and related accessories.

- 2.1 Remove the battery box cover and inspect all visible battery cables for loose wiring or damage.
- 2.2 Check that the battery hold-down is secure.

IMPORTANT: Aerodynamic components decrease drag force as a vehicle moves, thereby improving fuel efficiency. If replacement of an

Pre- and Post-Trip Inspections and Maintenance

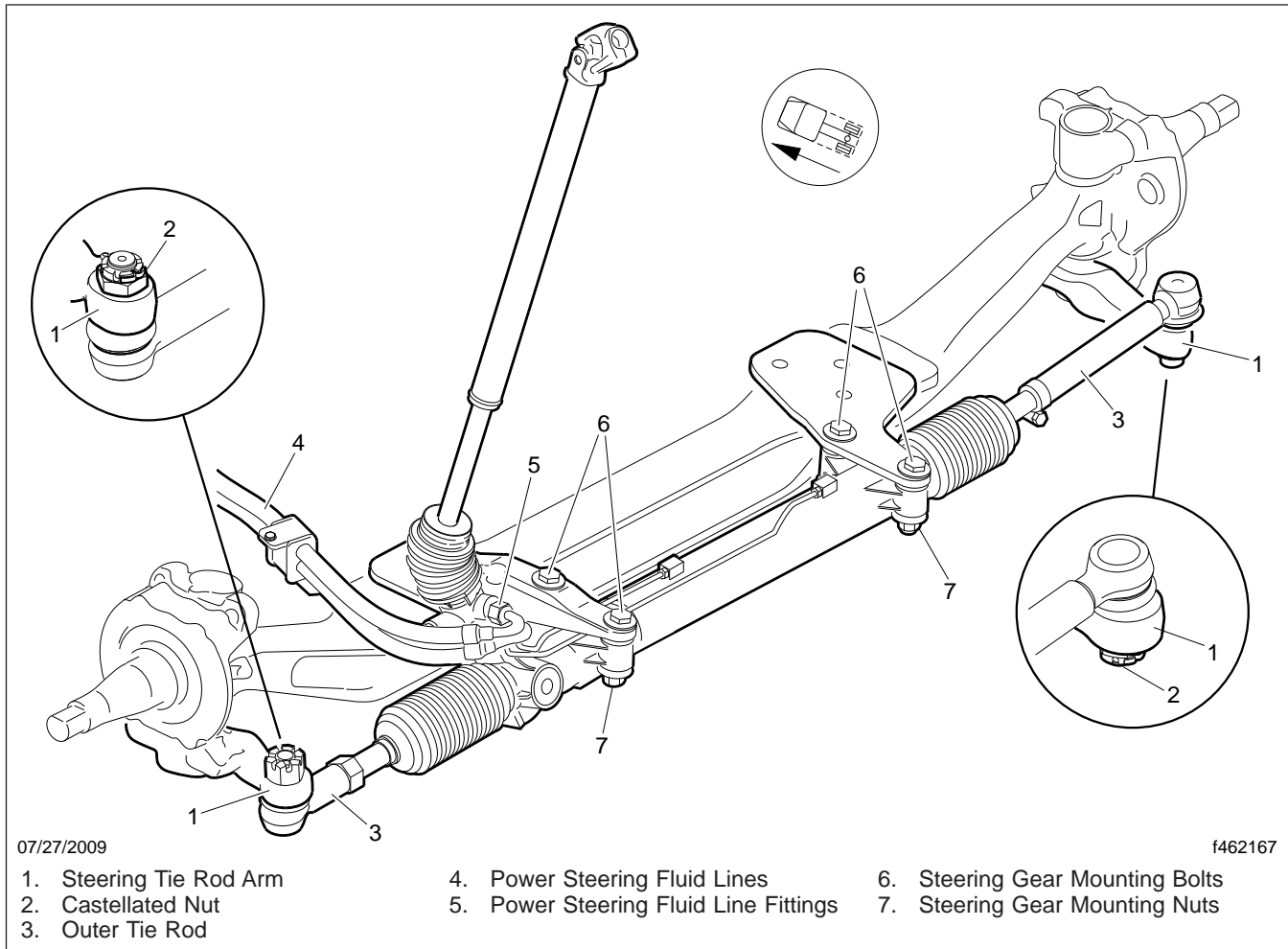

Fig. 21.17, Rack and Pinion Steering Gear Assembly

aerodynamic component is necessary, replacement components must meet or exceed the drag reduction performance of the originally installed component in order to maintain compliance with greenhouse gas and full efficiency regulations (GHG14).

3. Inspect the following aerodynamic components, if equipped, for structural damage, cracks, or wear.
 - Chassis fairings
 - Roof fairing/deflector
 - Side skirts
 - Cab/sleeper extenders

- Battery access cover

Engine Compartment Inspection and Adjustments

IMPORTANT: If replacement of the hood or bumper is necessary, the replacement component must meet or exceed the drag reduction performance of the originally installed item in order to maintain compliance with greenhouse gas and full efficiency regulations (GHG14).

1. Inspect the bumper and hood for structural damage, cracks, or wear.

Pre- and Post-Trip Inspections and Maintenance

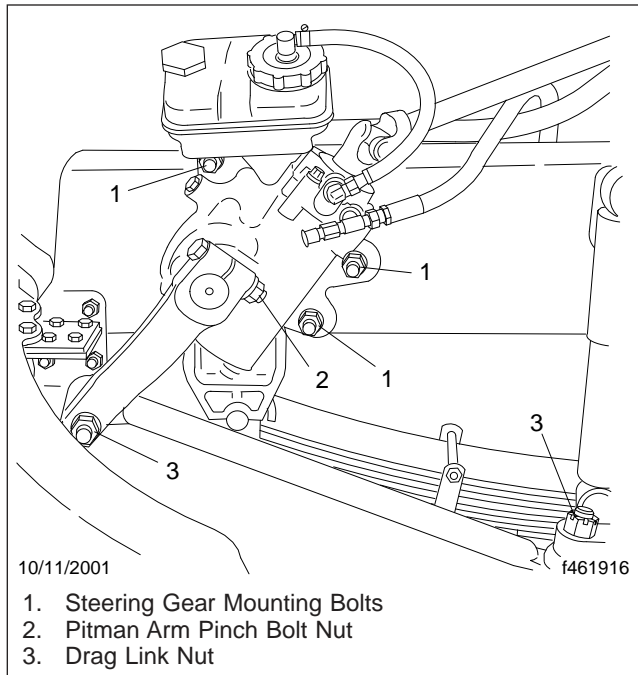

Fig. 21.18, Integral Steering Gear Fasteners

2. Check the hydraulic clutch reservoir, if equipped. If necessary, add DOT 4 brake fluid.
3. Inspect the radiator and heater hoses, including the clamps and support brackets.
 - 3.1 Inspect the radiator and charge air cooler for damage and accumulated debris. Straighten bent or damaged fins to permit airflow across all areas of the cores.
 - 3.2 Make sure the radiator inlet and outlet hoses are pliable and are not cracking or ballooning.
 - 3.3 Make sure the heater hoses are pliable and are not cracking or ballooning.
 - 3.4 Tighten hose clamps as necessary.

NOTE: When traveling through areas of high insect concentration, it may be necessary to clean the exterior of the radiator or the charge air cooler core as often as every 200 miles (320 km).

IMPORTANT: Do not overtighten hose clamps, as hose life can be adversely affected.

- 3.5 Ensure hose support brackets are securely fastened. Make sure hoses are not located near sources of wear, abrasion, or high heat.

IMPORTANT: When replacing hoses, install service-type knitted or braided yarn-reinforced neoprene hose. Extended-service-life silicone hoses may also be used. See the Alliance Parts Catalog at www.alliancebrandparts.com or contact your Freightliner Dealer.

4. Check the steering wheel for excessive play.
 - 4.1 Start the engine. With the front tires straight ahead, turn the steering wheel until motion is observed at the front wheels.
 - 4.2 Align a reference mark on the steering wheel to a rule, then slowly turn the steering wheel in the opposite direction until motion is again detected at the wheels.
 - 4.3 Measure the lash (free play) at the rim of the steering wheel. Excessive lash exists if steering wheel movement exceeds 2-1/2 inches (64 mm) with a 20-inch (508-mm) steering wheel, or 2-1/4 inches (57 mm) with an 18-inch (450-mm) steering wheel.
 - 4.4 If there is excessive lash, check the steering system for wear or incorrect adjustment before operating the vehicle.

22

Cab Appearance

| | |
|----------------------------------|------|
| Cab Washing and Polishing | 22.1 |
| Care of Fiberglass Parts | 22.1 |
| Care of Chrome Parts | 22.1 |
| Care of Exterior Lights | 22.1 |
| Dashboard Care | 22.2 |
| Vinyl Upholstery Cleaning | 22.2 |
| Velour Upholstery Cleaning | 22.3 |

Cab Appearance

Cab Washing and Polishing

IMPORTANT: Carefully read all instructions before using or applying any cleaner or product on the vehicle or components. Failure to follow manufacturers' recommendations can result in damage to the finish.

 **WARNING**

Do not power wash or steam clean the engine bay in the area of vehicle electrical components such as the SAM Cab, SAM Chassis, or powernet distribution box. Water intrusion can permanently damage these components, which could result in fire, personal injury, or property damage.

To protect the finish of your new vehicle, follow these guidelines carefully.

- During the first 30 days, rinse your vehicle frequently with water. If the vehicle is dirty, use a mild liquid soap. Do not use detergent.
- During the first 30 days, do not use anything abrasive on your vehicle. Brushes, chemicals, and cleaners may scratch the finish.
- During the first 120 days, do not wax your vehicle.

To extend the life of your vehicle's finish, follow these guidelines.

- Avoid washing your vehicle in the hot sun.
- Always use water. After the cab is completely washed, dry it with a towel or chamois.
- Do not dust painted surfaces with a dry cloth, as this will scratch the paint.
- Do not remove ice or snow from a painted surface with a scraper of any sort.
- To prevent damage to the finish, wax it regularly. Before waxing, if the finish has become dull, remove oxidized paint using a cleaner specifically designed for this purpose. Remove all road tar and tree sap before waxing. Freightliner recommends that a quality brand of cleaner or cleaner-polish and polishing wax be used.
- Do not let diesel fuel or antifreeze stand on a painted surface. If either should occur, rinse the surface off with water.

- To prevent rust, have any nicks or other damage on the finish touched up as soon as possible.
- Park your vehicle in a sheltered area whenever possible.

Care of Fiberglass Parts

Wash unpainted fiberglass air fairings and shields monthly with a mild detergent, such as dishwashing liquid. Avoid strong alkaline cleansers.

Apply a wax specifically designed for fiberglass.

Care of Chrome Parts

To prevent rust, keep chrome parts clean and protected at all times. This is especially important during winter driving and in coastal areas where there is exposure to salt air.

When cleaning chrome parts, use clean water and a soft cloth or sponge. A mild detergent may also be used.

Sponge gently, then rinse. If necessary, use a non-abrasive chrome cleaner to remove stubborn rust or other material. Do not use steel wool.

To help protect the chrome after cleaning, apply a coat of polishing wax to the surface. Never use wax on parts that are exposed to high heat, such as exhaust pipes.

Care of Exterior Lights

Clean the headlight lenses by hand only, using a flannel cloth with mild, non-caustic soap or detergent, and water.

 **CAUTION**

Do not use a power buffer, paper towels, chemical solvents, or abrasive cleaners on the headlight lens, all of which can remove the UV coating from the surface, and result in yellowing of the lens.

Dashboard Care

NOTICE

When cleaning the dashboard, instrument panel, or gauge lens covers, do not use Armor-All Protectant®, STP Son-of-a-Gun®, window cleaner, or other equivalent treatments. These cleaners contain vinyl plasticizers which can cause stress crazing in the interior plastic panels and can result in cracking of the panels. Some cleaners can also have an adverse effect on the clear plastic of instrument panels and gauge lens covers, resulting in a foggy or cloudy appearance. This type of damage is not covered by vehicle warranty.

To clean the dashboard, instrument panel, and gauge lens covers, use a cloth dampened with warm soapy water. Make certain to wring the cloth out well before cleaning, as excess water will damage the electrical components.

Vinyl Upholstery Cleaning

To prevent soiling, frequent vacuuming or light brushing to remove dust and dirt is recommended. Harsh cleaning agents can cause permanent damage to vinyl upholstery. To preserve the upholstery and prevent damage, carefully review the following sections for recommended cleaning procedures. Waxing or refinishing improves soil resistance and cleanability for all vinyls. Any hard wax, such as that used on automobiles, may be used.

Ordinary Dirt

Wash the upholstery with warm water and mild soap, such as saddle or oil soap. Apply soapy water to a large area and allow to soak for a few minutes, then rub briskly with a cloth to remove the dirt. This can be repeated several times, as necessary.

If dirt is deeply imbedded, use a soft bristle brush after applying the soap.

If dirt is extremely difficult to remove, wall-washing preparations normally found around the home can be used. Powdered cleaners, such as those used for sinks and tiles, are abrasive and must be used with caution as they can scratch the vinyl or give it a permanent dull appearance.

Chewing Gum

Harden the gum with an ice cube wrapped in a plastic bag, then scrape it off with a dull knife. Any remaining traces of gum can be removed with an all-purpose light oil (peanut butter will also work) and wiped off.

Tars, Asphalts, and Creosote

Each of these items stains vinyl after prolonged contact. They should be wiped off immediately and the area carefully cleaned, using a cloth dampened with naphtha.

Paint, Shoe Heel Marks

Paint should be removed immediately. Do not use paint remover or liquid-type brush cleaner on vinyl. An unprinted cloth, dampened with naphtha or turpentine may be used. Use care to prevent contact with parts of the upholstery that are not vinyl.

Sulfide Stains

Sulfide compounds, such as those found in eggs and some canned goods, can stain after prolonged contact with vinyl. These stains can be removed by placing a clean, unprinted piece of cloth over the spotted area and pouring a liberal amount of 6 percent hydrogen peroxide onto the cloth. Allow the saturated cloth to remain on the spot for 30 to 60 minutes. For stubborn spots, allow the hydrogen-peroxide saturated cloth to remain on the area overnight. Use caution to prevent the solution from seeping into the seams, or it will weaken the cotton thread.

Nail Polish and Nail Polish Remover

Prolonged contact with these substances causes permanent damage to vinyl. Careful blotting immediately after contact minimizes damage. Do not spread the liquid during removal.

Shoe Polish

Most shoe polishes contain dyes which penetrate vinyl and stain it permanently. Shoe polish should be wiped off as quickly as possible using naphtha or lighter fluid. If staining occurs, try the procedure used for sulfide stains.

Cab Appearance

Ball Point Ink

Ball point ink can sometimes be removed if rubbed immediately with a damp cloth, using water or rubbing alcohol. If this does not work, try the procedure used for sulfide stains.

Miscellaneous

If stains do not respond to any of the treatments described above, it is sometimes helpful to expose the vinyl to direct sunlight for up to 30 hours. Mustard, ball point ink, certain shoe polishes, and dyes often bleach out in direct sunlight, leaving the vinyl undamaged.

Velour Upholstery Cleaning

To prevent soiling, frequent vacuuming or light brushing to remove dust and dirt is recommended. Spot clean with a mild solvent or an upholstery shampoo, or the foam from a mild detergent. When using a solvent or a dry-cleaning product, follow the instructions carefully, and clean only in a well-ventilated area. Avoid any product that contains carbon tetrachloride or other toxic materials. With either method, pretest a small area before proceeding. Use a professional upholstery cleaning service when extensive cleaning is needed.

Grease and Oil-Based Stains

Dampen a small absorbent cloth with dry-cleaning solvent or spot remover. Apply the cloth carefully to the spot from the outer edge to the center. Pat and blot the spot with a clean, dry cloth. Repeat several times, as necessary, turning the cloths so that the stain does not redeposit on the fabric.

Sugar and Water-Based Stains

Apply water-based detergent or cleaner, working in circular motions. Pat and blot as dry as possible. Repeat, if necessary, before drying thoroughly.

Chewing Gum or Wax

Harden the gum or wax with an ice cube wrapped in a plastic bag, then scrape it off with a dull knife. Excess wax can be absorbed by placing a thick white blotter over the wax and heating with a warm (not hot) iron. Remove the remainder by using the procedure for grease and oil-based stains.

Mildew

Brush the dry fabric with a soft brush. Sponge with detergent, and blot. If the fabric is colorfast, dilute a teaspoon of bleach in one quart (one liter) of cool water. Apply with a swab, directly on the mildew stain. Dab repeatedly with clear, cool water, and blot dry.

23

Headlight Aiming

| | |
|-------------------------------|------|
| Preliminary Checks | 23.1 |
| Checking Headlight Aim | 23.1 |
| Adjusting Headlight Aim | 23.1 |

Headlight Aiming

Preliminary Checks

Before checking or adjusting the headlight aim, do the following.

- Check that the hood is closed and latched.
- Remove any large amounts of mud or ice from the underside of the fenders.
- Check the springs for sagging or broken leaves.
- Check the suspension for proper functioning of the leveling mechanism. On cabs with air suspensions, make sure that the height is properly adjusted.
- Check for damage to the hood and hinge assembly. Repair as necessary.
- With the vehicle unloaded, check that the tires are inflated to the recommended air pressure.
- Clean the headlight lenses. Use a soft cloth with mild, non-caustic soap or detergent, and water.

Checking Headlight Aim

1. Park the vehicle on a level surface, 25 ft (7.6 m) away from, and perpendicular to, a vertical screen or wall. Shut down the engine and set the parking brake. Chock the tires.
2. Each headlight has a height adjusting dot. See [Fig. 23.1](#). Measure the distance from the ground to the height adjusting dot on each headlight ([Fig. 23.2](#), Item A). Note those distances.
3. On the screen or wall, mark the locations of each headlight bulb center using the distances found in step 2. See [Fig. 23.2](#), Items 2 and 3.
4. Turn on the low-beam headlights.
5. Check the vertical adjustment of the low beams. The center of each beam projection should fall on or near the marks made during step 3. See [Fig. 23.3](#).
6. Use [Table 23.1](#) to determine the maximum vertical distance allowable between the marks on the wall and the center of each low-beam projection.
If the distance between either projection center and the mark made on the wall or screen is greater than the maximum distance given in

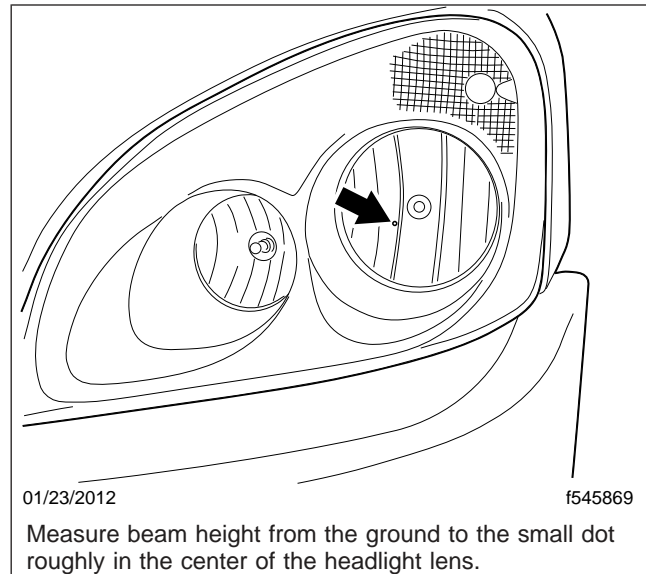

Fig. 23.1, Headlight Beam Height Adjusting Dot

[Table 23.1](#), adjust the vertical positioning of that headlight.

Adjusting Headlight Aim

NOTE: Freightliner vehicles are offered with various headlight assembly options. Because of the various options, the location of adjustment screws on your vehicle's headlight assembly may vary from what is shown here.

The adjusting screw is located on the lower outside corner of the headlight assembly. See [Fig. 23.4](#). Turn the adjusting screw clockwise to raise the beam and counterclockwise to lower it, until the beam pattern meets the acceptable standard.

Headlight Aiming

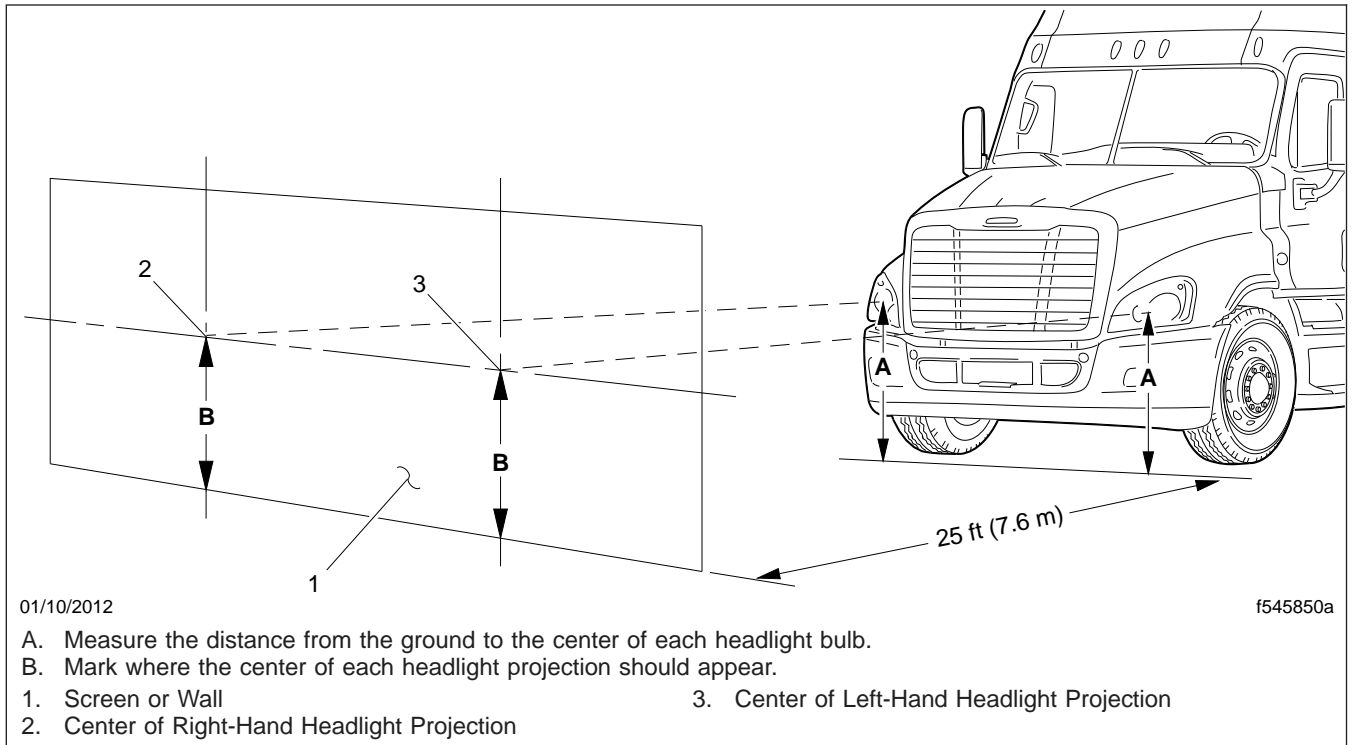

Fig. 23.2, Headlight Aiming Screen/Wall

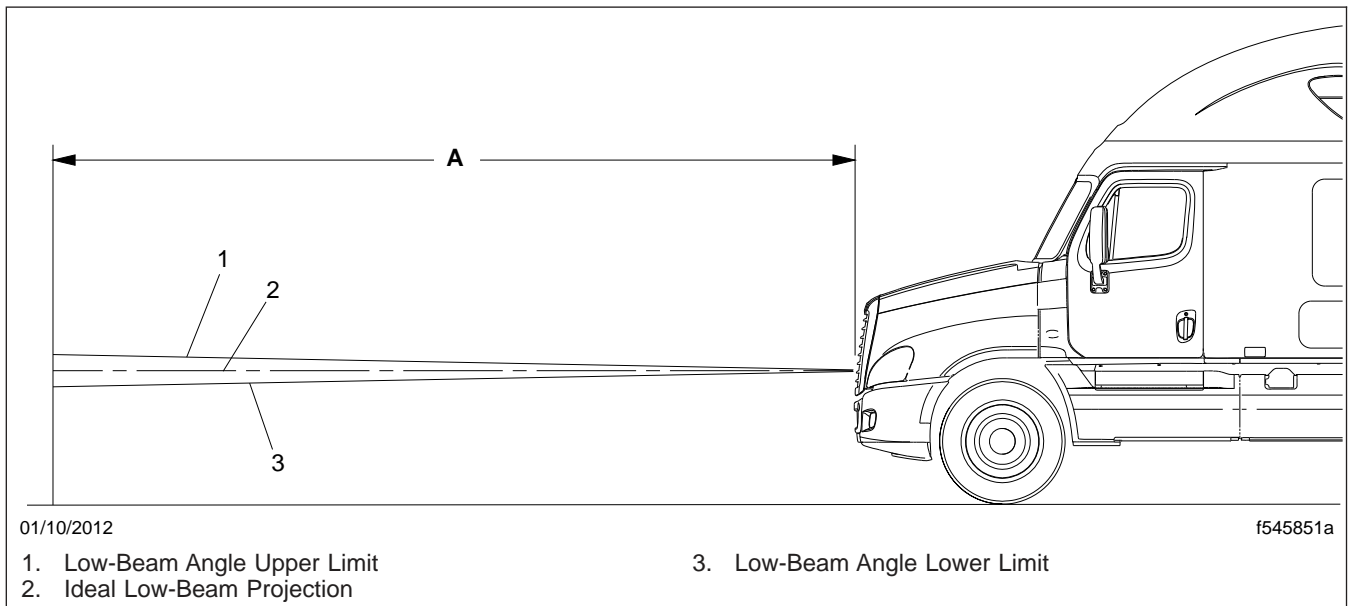

Fig. 23.3, Vertical Low-Beam Headlight Variation Limits

Headlight Aiming

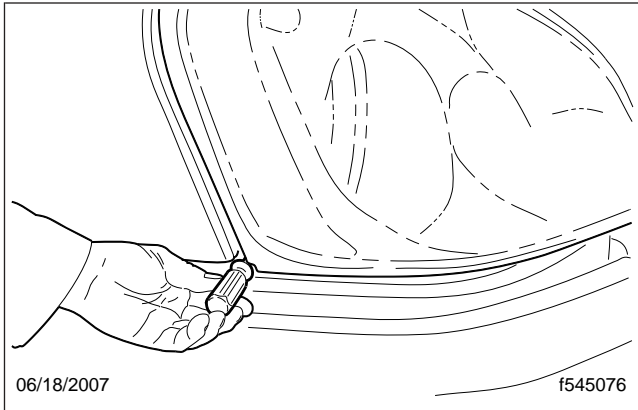

Fig. 23.4, Headlight Adjusting

| Vertical Low-Beam Headlight Variation Limits | | | |
|--|--|---|---|
| Distance Between Ground and Headlight: in (mm) | Desired Variation (Fig. 23.3, Item 2): in (mm) | Upper Limit (Fig. 23.3, Item 1): in (mm) up | Lower Limit (Fig. 23.3, Item 3): in (mm) down |
| 22–36 (560–900) | 0 | 3.9 (100) | 3.9 (100) |
| 36–48 (900–1200) | 2 (50) down | 2 (50) | 6 (150) |
| 48–54 (1200–1400) | 2.5 (64) down | 1.6 (40) | 6.5 (165) |

Table 23.1, Vertical Low-Beam Headlight Variation Limits

24

In an Emergency

| | |
|---|------|
| Hazard Warning Lights | 24.1 |
| Fire Extinguisher | 24.1 |
| Emergency Kit, Optional | 24.1 |
| Emergency Filter Replacement, Davco | 24.1 |
| Emergency Starting With Jumper Cables | 24.2 |
| Towing | 24.4 |
| Fire in the Cab | 24.7 |

In an Emergency

Hazard Warning Lights

The hazard warning light switch is located on the dash in what is referred to as the master module. See [Fig. 24.1](#). The hazard lights can be activated regardless of the ignition switch position.

To activate the hazard lights, push the center of the switch once. The switch will blink at the same rate that the hazard lights flash. Push the switch again to turn them off. All the turn signal lights on the vehicle and trailer, as well as the turn signal indicators in the ICU, flash simultaneously when the hazard lights are activated.

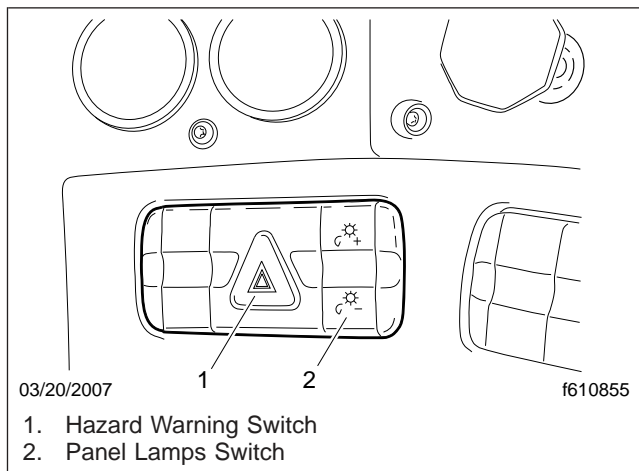

Fig. 24.1, Master Module

Fire Extinguisher

A fire extinguisher is located either in the cab by the driver's door, or in the baggage compartment.

Emergency Kit, Optional

An optional emergency kit is located in the cab. The kit includes one or more of the following: a first aid kit, a reflective vest, a triangular reflector, a flare kit, and (on vehicles with a Davco fuel/water separator) a spin-on fuel filter element.

If there is an emergency while driving, cautiously pull off the road. Turn on the hazard warning lights. Place the flares and reflector along the side of the road to alert other drivers that an emergency situation exists.

⚠ WARNING

Use extreme care when placing flares in emergency situations that involve exposure to flammable substances such as fuel. An explosion or fire could occur causing serious personal injury.

Emergency Filter Replacement, Davco

If the filter cover on the Davco fuel/water separator is broken, it will not be possible to operate the vehicle. A standard spin-on filter will correct this problem.

Refer to the Davco web site (www.davcotec.com) for additional information.

To replace the filter on all Davco fuel/water separators, follow this procedure:

1. Drain the fuel until it is below the level of the collar. See [Fig. 24.2](#) for the model 232/233 fuel/water separator and [Fig. 24.3](#) for the model 382 fuel/water separator.
2. Remove the vent and seal.

NOTE: The vent and seal are not needed in the emergency replacement. They should be retained for later installation at the time when the cover is replaced.

3. Remove the collar using the DAVCO fuel-water separator wrench. Do not use pliers or channel-lock pliers.
4. Remove the cover, cover seal, and spring. Retain them for later assembly.
5. Remove the filter element and dispose of it properly.

NOTE: Remove the rubber grommet from the stud.

6. Install the standard engine spin-on filter (included in the emergency kit) on the threaded stud.
7. Install the cover, cover seal, and spring, as removed.
8. Install the collar over the cover. Tighten the collar finger-tight.
9. Start the engine and run it at increased rpm for one minute to purge air from the fuel lines.

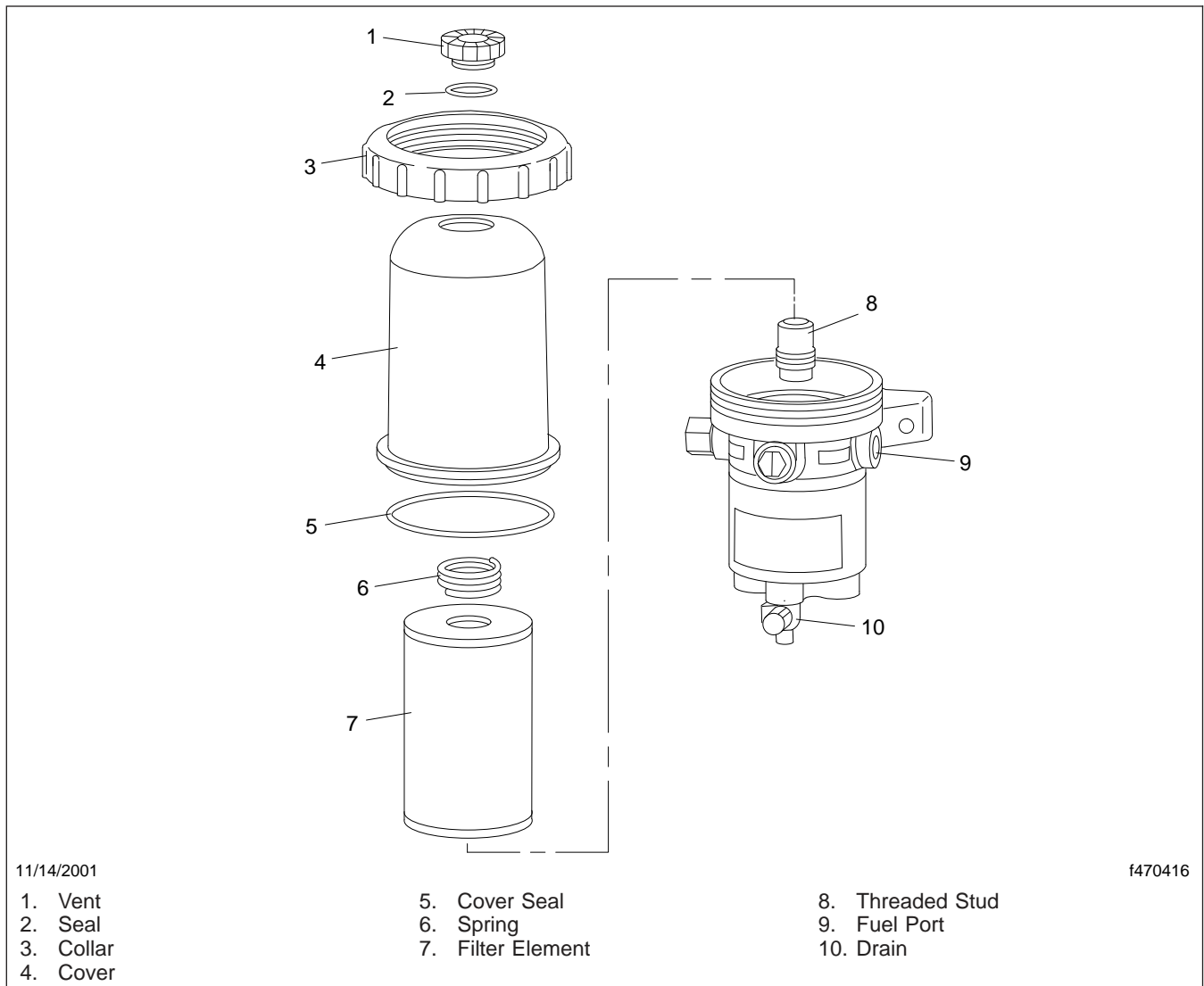

Fig. 24.2, Davco Model 232 and 233 Fuel/Water Separator

Emergency Starting With Jumper Cables

When using jumper cables, follow the instructions below.

⚠ WARNING

Batteries release explosive gas. Do not smoke when working around batteries. Put out all flames and remove all sources of sparks or intense heat

in the vicinity of the battery. Do not allow the vehicles to touch each other. Do not lean over the batteries when making connections, and keep all other persons away from the batteries. Failure to follow these precautions could lead to severe personal injury as a result of an explosion or acid burns.

⚠ CAUTION

Make sure both electrical systems are the same voltage. Electronic devices on both vehicles can

In an Emergency

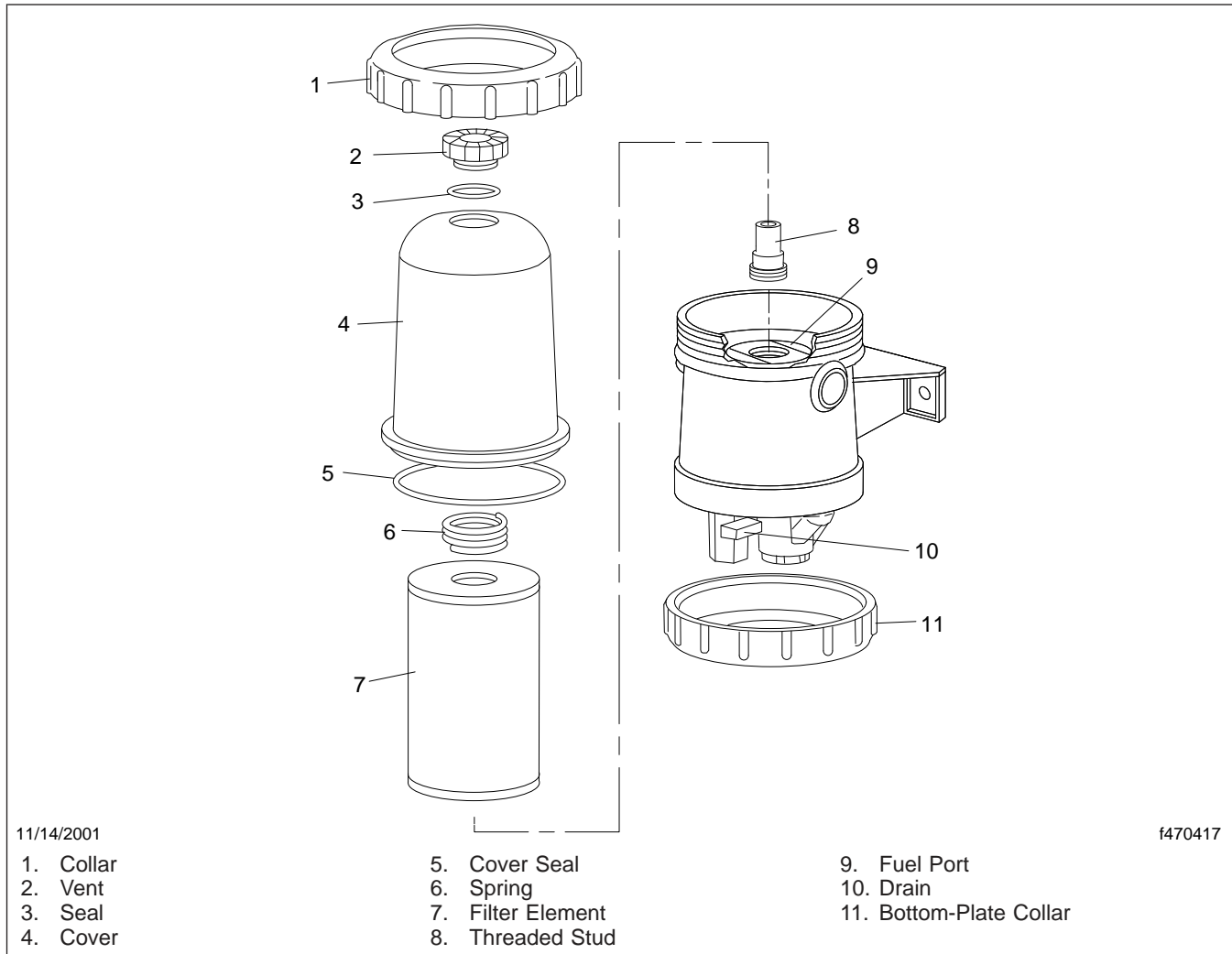

Fig. 24.3, Davco Model 382 Fuel/Water Separator

be damaged when connected to a vehicle with a different operating voltage.

NOTE: On vehicles equipped with optional underhood jump start posts, connect to these posts instead of the batteries.

1. Apply the parking brakes and turn off the lights and all other electrical devices.
2. Remove the battery box cover by pulling on the end of each hold-down latch until the end clears the catch, then pivoting the latches out of the way, and lifting off the cover. See [Fig. 24.4](#).

CAUTION

Always connect the battery, jumper cables, and charger correctly (positive-to-positive and negative-to-negative). Connecting a charging device backwards (positive-to-negative) can severely damage the vehicle electrical content and cause non-warrantable failures.

3. Connect the positive (+) jumper cable to the positive battery post on the Cascadia needing the jump start, then connect the other end of the positive jumper cable to the positive battery or

In an Emergency

jump start post of the vehicle providing the jump. See Fig. 24.5.

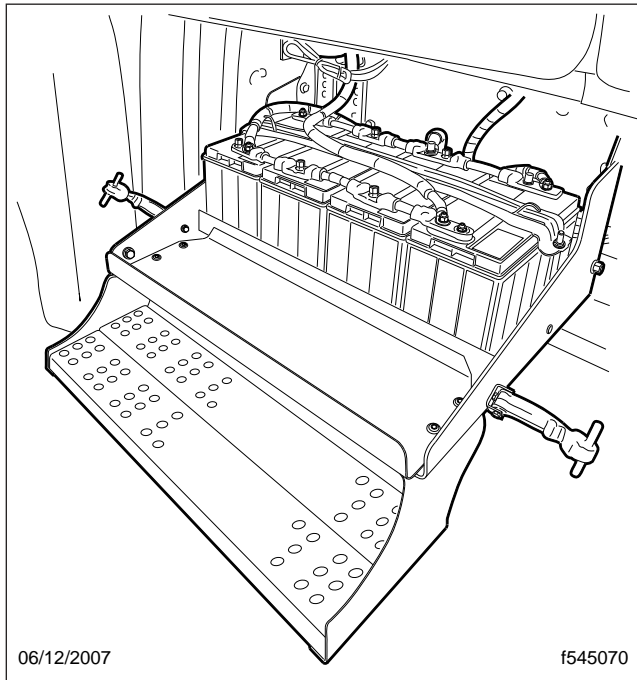

Fig. 24.4, Battery Compartment

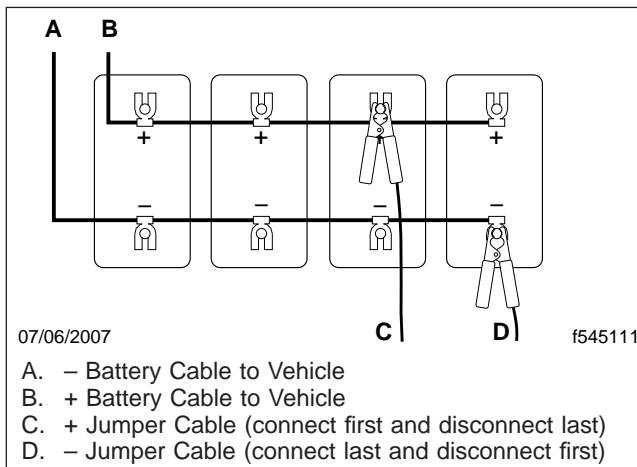

Fig. 24.5, Jumper Connections

WARNING

Do the next step exactly as instructed and do not allow the clamps of one cable to touch the clamps of the other cable. Otherwise, a spark

could occur near a battery, possibly resulting in severe personal injury from explosion or acid burns.

4. Connect one end of the second jumper cable to the negative terminal of the booster battery, and connect the other end of the cable to the negative battery post of the Cascadia needing the jump start.
5. Start the engine of the vehicle with the booster batteries, and let the engine run a few minutes to charge the batteries of the other vehicle.
6. Attempt to start the engine of the vehicle with the batteries receiving the charge. Do not operate the starter longer than 30 seconds, and wait at least two minutes between starting attempts to allow the starter to cool.
7. When the engine starts, let it idle a few minutes.

WARNING

Do the next step exactly as instructed and do not allow the clamps of one cable to touch the clamps of the other cable. Otherwise, a spark could occur near a battery, possibly resulting in severe personal injury from explosion or acid burns.

8. Disconnect the grounded cable from the frame or other non-battery location, then disconnect the other end of the cable.
9. Disconnect the remaining cable from the newly charged battery (or jump-start post if equipped) first, then disconnect the other end.
10. Install the cover; be sure it is positioned properly before fastening the latches.

Towing

When it is necessary to tow the vehicle, make sure the instructions below are closely followed to prevent damage to the vehicle.

WARNING

Do not tow an unbraked vehicle if the combined weight of both vehicles is more than the sum of

In an Emergency

the gross axle weight ratings (GAWR) of the towing vehicle. Otherwise brake capacity will be inadequate, which could result in personal injury or death.

Front Towing Hookup

1. Disconnect the battery ground cables.

NOTICE

Failure to remove the axle shafts when towing the vehicle with the rear wheels on the ground will result in damage to the transmission and other drivetrain components.

2. Remove both drive axle shafts. On dual drive axles, if the vehicle is to be lifted and towed, remove only the rearmost drive axle shafts.
On vehicles equipped with an air fairing, remove both the forward and rearmost drive axle shafts if there is insufficient towing clearance.
3. Cover the ends of the hubs with metal plates or plywood cut to fit the axle opening, and drilled to fit the axle shaft studs. This prevents lubricant from leaking out and will keep contaminants from getting into and damaging the wheel bearings and axle lubricant.

NOTICE

Failure to protect the frame rails from the chains could cause damage, leading to eventual frame failure.

4. On dual drive axles, if the vehicle is to be lifted and towed, chain the forward rear-axle assembly to the vehicle frame. Use protection to keep the chains from damaging the frame.
5. Remove the bumper end caps and chrome bumper (if equipped).
6. Attach the towing device. Do not pass a sling (for example, a rope or chain) from one tow hook to another to fasten for towing. Known as reeving, this practice is not permissible in most industrial applications of towing and hoisting. Reeving can overload the hooks and result in damage to the vehicle. See [Fig. 24.8](#).

7. Lift the vehicle and secure the safety chains. If extra towing clearance is needed, remove the front wheels.

NOTE: Due to the many variables that exist in towing, positioning the lifting and towing device is the sole responsibility of the towing-vehicle operator.

8. Connect the clearance lights, taillights, and signal lights. Connect any special towing lights required by local regulations.

WARNING

Failure to chock the tires or connect the tow truck's air brake system before releasing the spring parking brakes could allow the disabled vehicle to suddenly roll. This could cause property damage or personal injury.

9. Chock the tires on the disabled vehicle and connect the towing vehicle's air brake system to the vehicle being towed. Then, release the spring parking brakes and remove the chocks.

Rear Towing Hookup

NOTICE

Using a rear towing hookup on a vehicle equipped with a roof fairing could cause damage to the cab structure.

If reverse towing at speeds above 45 mph (70 kph) is necessary, note the following precautions:

- **Remove the rubber flex extenders (for side extenders equipped with middle brackets) or the side extender assemblies (without middle brackets). Failure to do so could cause damage to the side extenders and/or loss of the rubber flex extenders.**
 - **Hold down the cab with tension straps looped over the cab shocks and under the frame rails. Failure to do so could allow the wind load to lift the cab unexpectedly, resulting in damage to the air springs and other components.**
1. If the vehicle is equipped with side extenders, and reverse towing at speeds above 45 mph (70

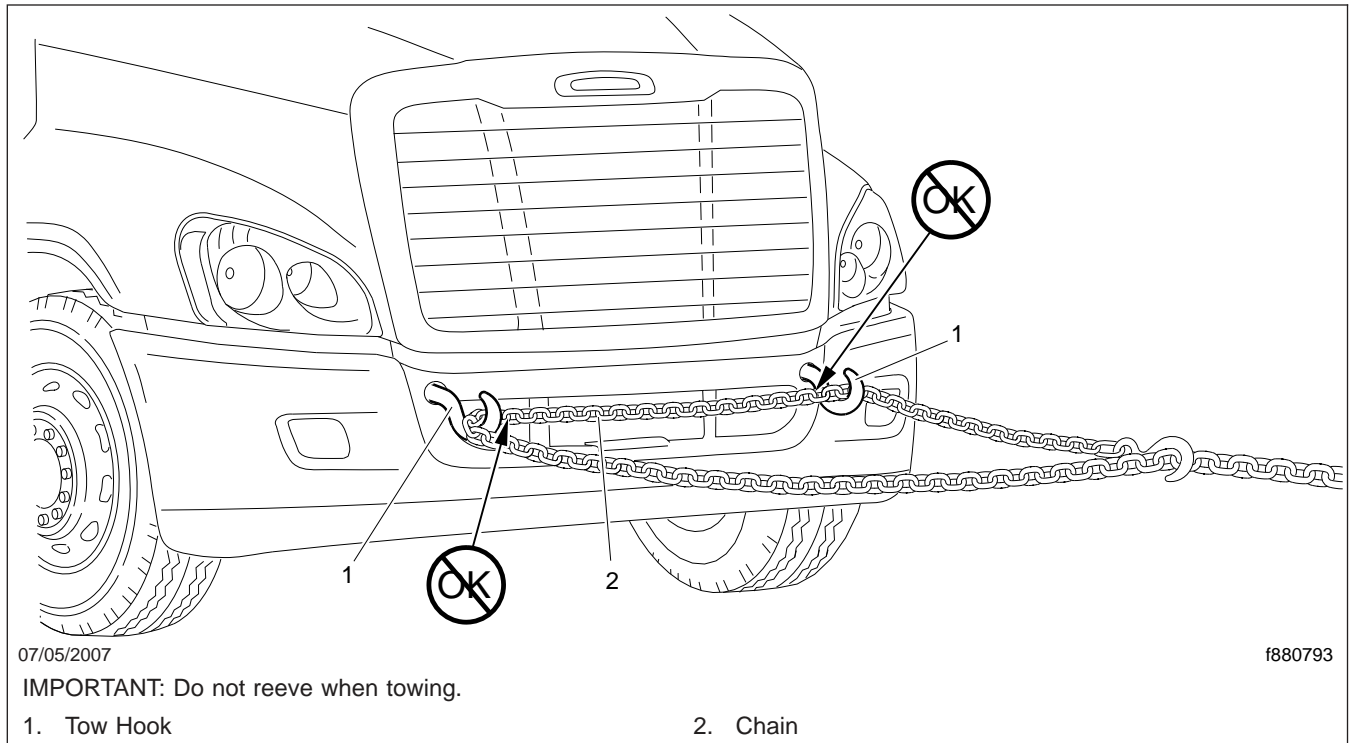

Fig. 24.6, Reeving

kph) is necessary, prepare the side extenders as follows:

- If middle brackets are installed on the side extenders, as shown in [Fig. 24.7](#), remove the rubber flex extenders.
- If middle brackets are not installed on the side extenders, remove the side extenders from the cab.

2. If the vehicle is equipped with cab air suspension, and reverse towing at speeds above 45 mph (70 kph) is necessary, hold down the cab as follows:

- 2.1 Drain the air from the cab air springs.
- 2.2 Loop a 2-inch (5-cm) ratchet-style tension strap (rated 2000 lb [900 kg] minimum work load) over the top of the cab shock and under the frame rail. See [Fig. 24.8](#). Tighten the strap for a snug fit. If the cab is equipped with two or more shocks, restrain the aftmost shock on each side of the vehicle.

3. Place the front tires straight forward and secure the steering wheel in this position.
4. Disconnect the battery ground cables.

NOTICE

Failure to protect the frame rails from the chains could cause damage, leading to eventual frame failure.

5. On dual drive axles, using protection to keep the chains from damaging the vehicle frame, chain the forward-rear drive axle to the frame.
6. Attach the towing device.

NOTE: Due to the many variables that exist in towing, positioning the lifting and towing device is the sole responsibility of the towing-vehicle operator.

7. Lift the vehicle and secure the safety chains. If extra clearance is needed, remove the bumper extension if equipped.

In an Emergency

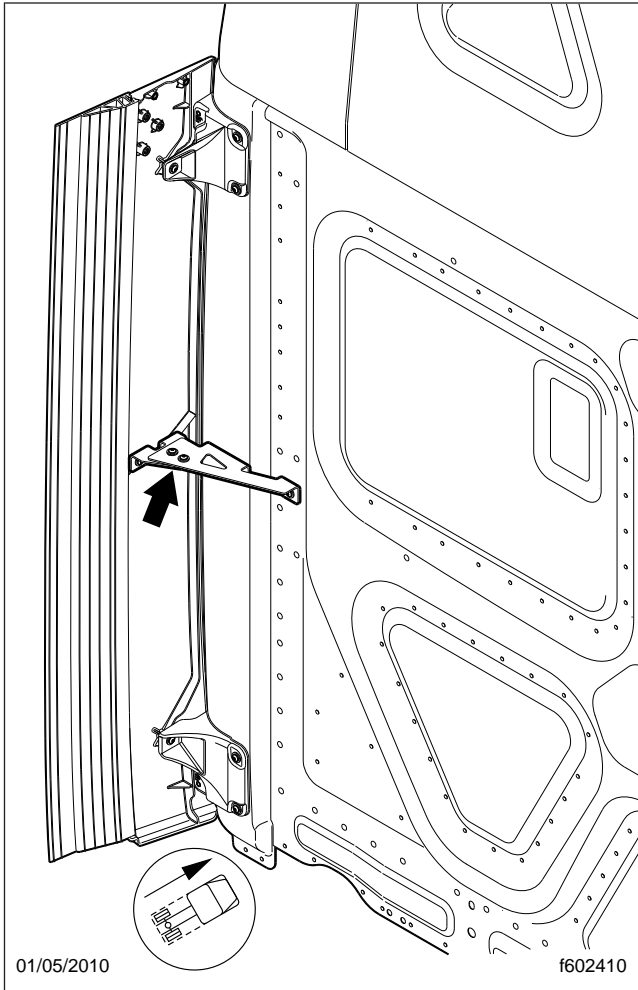

Fig. 24.7, Side Extender Middle Bracket

8. Connect the clearance lights, taillights, and signal lights. Also connect any special towing lights required by local regulations.

Fire in the Cab

The incidence of fire in heavy- and medium-duty trucks is rare, according to data from the National Highway Traffic Safety Administration. Federal Motor Vehicle Safety Standard #302 limits the flammability of specified materials used inside the cab, but despite this, most materials will burn. The cab of this vehicle contains urethane foam, which is of concern in this respect.



Fig. 24.8, Tension Strap Installed to Hold Down the Cab

WARNING

Urethane foam is flammable! Do not allow any flames, sparks, or other heat sources such as cigarettes or light bulbs to contact urethane foam. Urethane foam in contact with such heat sources could cause a serious, rapid fire, which could result in death, severe burns, or gas poisoning, as well as damage to the vehicle.

In Case of a Cab Fire

As quickly as possible, bring the vehicle to a safe stop, apply the parking brake, turn off the ignition, and get out of the vehicle.

25

Natural Gas Vehicles

| | |
|---|-------|
| Natural Gas Vehicles, General Information | 25.1 |
| Natural Gas Vehicles, Safety Precautions | 25.1 |
| Natural Gas Fuel Tank Filling Procedures | 25.3 |
| Natural Gas Detection System | 25.5 |
| Natural Gas Engine Starting | 25.9 |
| Major Repairs and Replacement of Natural Gas Components | 25.10 |

Natural Gas Vehicles

Natural Gas Vehicles, General Information

The vehicle can be equipped with a compressed natural gas (CNG) fuel system, or a liquefied natural gas (LNG) fuel system. CNG is made by compressing natural gas to less than 1% of its volume at standard atmospheric pressure. LNG is created by condensing natural gas into a liquid by cooling it to approximately -259°F (-162°C).

When vaporized at ambient temperatures, natural gas is less dense than air, and it rises and disperses. However, LNG is initially heavier than air due to its cryogenic temperature. When released in large amounts, it may drop or pool on the ground before its temperature rises enough to vaporize. Cold atmospheric conditions may prevent natural gas from dispersing quickly when released in large amounts.

Natural gas is nontoxic, but it can cause asphyxiation if present in very large concentrations.

CNG often contains an odor-producing chemical, while LNG does not have any odor. Users of natural-gas-fueled vehicles should never expect to detect natural gas leaks by scent.

For natural gas to burn, it must first vaporize, then mix with air in the proper proportions (flammable range is 5 to 15% by volume in air), and then be ignited.

A typical natural gas fuel system consists of:

- Fuel supply cylinders that store compressed gas at high pressure (CNG), or a tank that stores liquefied gas at an extremely low temperature (LNG).
- A vaporizer or heat exchanging device that changes LNG to gaseous form (LNG fuel systems only).
- Pressure relief and manual fuel shutoff valves.
- A filling connection with a check valve that prevents the gas from flowing back out of the fuel filling line.
- High-pressure and low-pressure fuel filters.
- A pressure control regulator that reduces the high fuel tank or cylinder pressure to the lower pressure needed for the engine.

- A fuel contents gauge that indicates the fuel supply in the tank or cylinders.

Figure 25.1 shows the locations of various components of a CNG installation.

Natural Gas Vehicles, Safety Precautions

DANGER

Natural gas is highly flammable. Failure to observe the following safety precautions could lead to the ignition of the natural gas, which could cause serious bodily injury or death.

CNG systems should be maintained and inspected exclusively by trained personnel with certifications in accordance with the applicable codes. As with all pressure vessels, CNG storage and fuel delivery systems are inherently dangerous and should be treated as such. Individuals involved in any aspect of CNG fuel system maintenance, emergency response, servicing, or testing must be properly trained and certified. Individuals who are not trained and certified in all aspects concerning CNG fuel delivery systems are not permitted to service, maintain, test, or inspect a system in any way.

Follow these safety precautions when operating or repairing a natural gas vehicle.

- Only certified LNG personal can fuel LNG trucks.
- Do not start the engine if a natural gas leak is detected.
- Transferring fuel is only allowed as long as a non-static hose is used. If a non-approved hose is used, static can build up and ignite the fuel. A correct hose can be obtained through Agility fuel systems.
- Do not attempt to cut any fuel supply piping components.
- Avoid open flames or sparks near a natural gas vehicle.
- Cover eyes and exposed skin when working on a natural gas fuel system or fueling a natural gas vehicle.



01/21/2014

f470613

- 1. Sleeper Leak Sensor (zone 3)
- 2. Engine Compartment Leak Sensor (zone 2)
- 3. Leak Detection Control Panel (zone 1) (overhead console)
- 4. Cylinder Shutoff Valve (back-of-cab box)
- 5. Shutoff Valve, Right Side Cylinder
- 6. Shutoff Valve and System Components, Left Side Cylinder
- 7. Fill Panel

Fig. 25.1, CNG Component Locations

Natural Gas Vehicles

- Permit no smoking or other ignition sources in, or within thirty feet of, a natural gas vehicle.
- Have CO₂ fire extinguishers (ABC minimum) located in a highly visible and easily accessible location.
- Use Purple-K powder (PKP) or a similar dry powder to extinguish an LNG fire. Do not attempt use water around an LNG fire.
- Always purge the fuel lines before performing maintenance or repairs on a natural gas fuel system. Refer to the system manufacturer's service manual or the vehicle's workshop manuals for the proper purging procedure.
- Always use a natural gas detector to test the system for leaks, whether an odor is present or not. Routinely inspect the fuel filtering and regulating mechanisms, and the fuel lines. An approved natural gas bubble solution can be used to pinpoint the exact location of leaks. Do not use soap and water. Soap and water can cause premature failure of the O-rings in the system.
- Make sure black caps are always on the PRD vent lines to reduce water build up in lines.
- Do not store a natural gas vehicle indoors for any extended period of time. Do not bring a natural gas vehicle indoors unless the workshop is equipped with a methane detection and ventilation system.

In Case of Emergency

If a vehicle has sustained damage or a leak has been discovered:

1. Turn the ignition switch off, and set the parking brake.
2. Exit the vehicle leaving as many doors and windows open as possible. Get at least 30 feet from the vehicle, and allow it to vent until it is safe to do the steps below.
3. Remove all ignition sources from the area surrounding the vehicle.
4. If it is safe to do so, close all fuel shutoff valves.
5. Use a natural gas detector, or approved NG bubble solution, to identify leaks in the fuel system.

Natural Gas Fuel Tank Filling Procedures

CNG Vehicle Fueling

CNG is moved from the fuel station storage tanks to the vehicle cylinders through a metered dispenser. During fueling, as pressure inside of the vehicle cylinders increases, so does the temperature. The dispenser shuts off when it determines the CNG cylinders are full.

CNG fuel cylinders cannot be filled to their full capacity of 3600 psi (24 800 kPa) in cooler weather. Since temperature change causes gas to expand and contract, less pressure in the cylinders on a cold day is equal to the same amount of gas at a higher pressure on a warm day. The fuel station dispenser has a temperature-pressure compensating device, which accounts for ambient temperature during fueling. See [Table 25.1](#) for approximate full cylinder pressures at various temperatures.

| CNG Temperature/Pressure Compensation Values | | |
|--|---------------------------------|---------------------------------|
| Temperature: °F (°C) | Fill Station Pressure Set Point | |
| | 3000 psi (20 684 kPa) Set Point | 3600 psi (24 821 kPa) Set Point |
| 100 (37.8) | 3415 (23 546) | 4086 (28 172) |
| 90 (32.2) | 3276 (22 587) | 3909 (26 952) |
| 80 (26.7) | 3138 (21 636) | 3754 (25 883) |
| 70 (21.1) | 3000 (20 684) | 3600 (24 821) |
| 60 (15.6) | 2861 (19 726) | 3445 (23 752) |
| 50 (10) | 2723 (18 774) | 3288 (22 670) |
| 40 (4.4) | 2584 (17 816) | 3131 (21 587) |
| 30 (-1.1) | 2446 (16 865) | 2973 (20 498) |
| 20 (-6.7) | 2307 (15 906) | 2814 (19 402) |
| 10 (-12.2) | 2169 (14 955) | 2655 (18 306) |
| 0 (-17.8) | 2031 (14 003) | 2495 (17 202) |
| -10 (-23.3) | 1893 (13 052) | 2336 (16 106) |
| -20 (-28.9) | 1755 (12 100) | 2180 (15 031) |
| -30 (34.4) | 1616 (11 142) | 2024 (13 955) |
| -40 (-40) | 1477 (10 184) | 1868 (12 879) |

Table 25.1, CNG Temperature/Pressure Compensation Values

Use the following steps to fuel a CNG vehicle.

1. Shut down the engine and apply the parking brake.

IMPORTANT: Close all windows and doors during the fueling process. Keeping windows and doors closed allows for easier leak detection inside the cab after fueling.

NOTE: If the fuel system has only back of cab tanks, the fuel fill is located behind the fuel access panel on the lower part of the cabinet, or below the tank cabinet in a separate box. If truck has saddle mount tanks, the fuel panel is located on the back end of the left side tank. Vehicles with back-of-cab cabinets and saddle tanks are have the fuel fill panel on the back end of the left side tank. See [Fig. 25.2](#) for side tanks, or [Fig. 25.3](#) for back-of-cab cabinet mounted fuel panel.

WARNING

Natural gas fuel tanks, lines, and valves are always pressurized. Always observe safety precautions. Failure to do so could lead to loss of control over a filling hose or to ignition of the natural gas, which could cause serious bodily injury, death, or severe property damage.

2. Ensure all fuel cylinder shutoff valves are open. See [Fig. 25.2](#).
3. Ensure the vehicle fuel system main shutoff valve is open.
4. If equipped, open the CNG fuel panel access door and remove the dust cap from the vehicle fuel fill port.
5. Ensure the O-ring is present inside the fuel fill port. If the O-ring has been dislodged or is missing, the station dispensing nozzle will not connect securely to the fill port.
6. Turn the selector knob on the service pump to the VENT position, if equipped.
7. Connect the quick coupling on the dispensing nozzle securely to the vehicle fuel fill port.
8. Turn the selector knob on the service pump to the FILL position, if equipped.

IMPORTANT: If at any time the service pump or vehicle begins to vent CNG uncontrollably, notify a station attendant or activate the service sta-

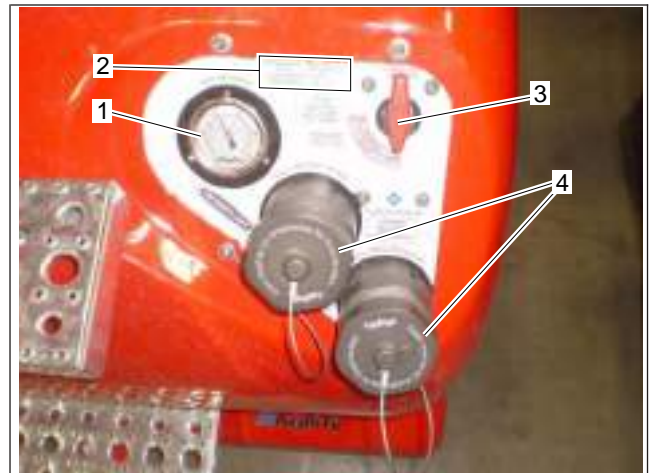

1. High-Pressure Gauge
2. Fuel Cylinder Information Sticker
3. Manual Shutoff Valve
4. Fuel Fill Port

Fig. 25.2, CNG Fuel Cylinder Fill Panel (side tank shown)

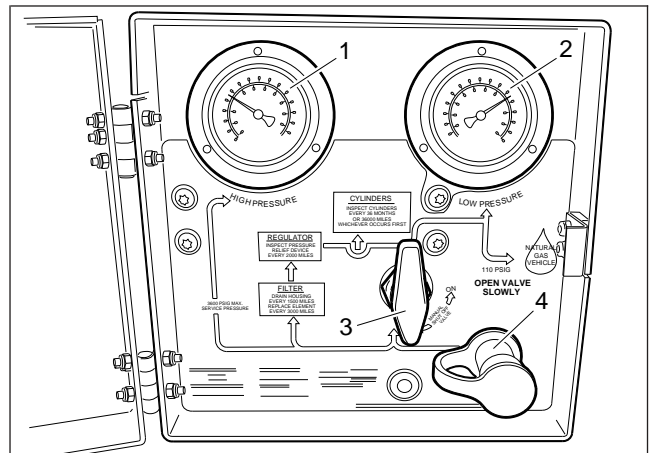

1. High Pressure Gauge
2. Low Pressure Gauge
3. Manual Fuel Shutoff Valve
4. Fuel Fill Port and Dust Cap

Fig. 25.3, CNG Under Cabinet Fuel Panel (under cabinet shown)

tion emergency shut-off switch to cease the flow of CNG.

Natural Gas Vehicles

9. Switch on the service pump. A slight hissing noise may be heard as the fuel cylinders fill.
10. Watch the pressure gauge on the service pump. When the gauge reads approximately 3600 psi (24 800 kPa), or when the fill pressure stops climbing, the CNG cylinders are full. The service pump will shut itself down automatically. See [Table 25.1](#) for pressure compensation values based on ambient temperatures.
11. Move the selector knob on the service pump to the VENT position, if equipped. A short hiss will be heard as a small amount of natural gas is vented into the hose.

WARNING

Do not attempt to remove the fill station nozzle from the tank fill fitting until venting of pressure is noted. If no venting occurs, ask for assistance from the station attendant. Removing an unvented coupling could result in an uncontrolled hose, which could lead to property damage or personal injury.

12. Remove the station dispensing nozzle from the vehicle fill port.

NOTE: Some fill ports and dust caps contain a magnetic start interrupt sensor to prevent a truck from being started and driven away with the fill hose connected. These caps must be installed correctly or vehicle will not start.

13. Install the dust cap on the vehicle fuel fill port and close the fuel panel access door, if equipped.

LNG Vehicle Fueling

Only certified LNG fueling personnel are authorized to fuel an LNG vehicle.

Natural Gas Detection System

A gas detection system is standard in all Daimler Trucks natural-gas-fueled vehicles. This system has a sensor in the engine compartment, one in the cab, and one in the sleeper (if equipped), all situated in high areas to detect natural gas buildup as a result of leaks.

The AMGADS III Plus is a natural gas detection system. This device is meant to serve as a supplemental warning only. It is not intended to replace standard safety practices that should be conducted around flammable gases.

IMPORTANT: To function properly, the gas detection system must be powered at all times. The gas detection system is directly powered by the batteries, and can only be powered off by disconnecting the batteries. When servicing a natural-gas-fueled vehicle, disconnect the batteries only when necessary, and do not leave the batteries disconnected for extended periods of time.

The lower flammability limit (LFL) is the smallest amount of the gas that supports a flame when mixed with oxygen and ignited. Zero percent (0%) LFL indicates a gas-free atmosphere. One hundred percent (100%) LFL indicates that gas concentration has reached its lower flammability limit (5% gas in air by volume). The red warning light and audible alarm located in the overhead console activate when a sensor detects gas fumes in concentrations above 50% LFL, and should allow ample time to utilize safety procedures. However, individuals with special needs should review the system with a professional safety engineer.

Alarm Procedure

Before operating the vehicle, the driver must be familiar with the procedures as shown on the interior sticker on the overhead panel (See [Fig. 25.4](#)) and the exterior sticker on the door (See [Fig. 25.5](#)).

IMPORTANT: If an audible alarm activates, do not operate any electrical switch, including lights. Avoid causing sparks and stay away from arcing switches and equipment. Do not use a telephone, including cellular phones or any types of portable communication or electronic devices that have a battery.

If the vehicle is in motion when the audible alarm activates, bring it to a safe stop, shut down the engine, and exit the vehicle. *Do not open the hood.*

If outside the vehicle when the audible alarm activates, *do not open the cab door or hood.*

In the event of an audible alarm, immediately follow these procedures, as allowed by conditions:



Fig. 25.4, Interior Warning Sticker



Fig. 25.5, Exterior Warning Sticker

1. Immediately shut off all engines. Extinguish any cigarettes, pilot lights, flames, or other sources of ignition in the area and adjacent areas.

2. Exit the vehicle leaving as many doors and windows open as possible, and move at least 30 feet away from vehicle. If the vehicle is parked, stay at least 30 feet away until it is safe to do the following.
3. Manually close all fuel shutoff valves, including those on the LNG tank or CNG cylinders.
4. If the vehicle is indoors (as in a service shop), immediately open shop windows and doors to provide extra ventilation to the area. Do not start the engine or any other type of equipment until the gas leak is corrected and the area cleared of natural gas.
5. Evacuate the area.
6. After the area is cleared of natural gas and the alarm is no longer active, have the vehicle inspected by a qualified technician.

IMPORTANT: Do not consider the area clear until all alarm indicators are off, and the alarm panel light returns to green.

Sensors

Gas detection sensors are located on the cab overhead console (zone 1), in the engine compartment on the frontwall (zone 2), and in the sleeper, if equipped (zone 3). The sensors are located in high areas, where rising gas vapors will pass by or accumulate. On some vehicles, there is a sensor located under the cab floor (zone 4). Zone 4 is not used on DTNA vehicles.

If the system detects that one of the sensors has been disconnected or has malfunctioned, the sensor fault light for that zone will illuminate. A failed sensor may trigger and lock on an alarm. If this happens have a qualified technician troubleshoot the system and make appropriate repairs.

The sensors are sensitive to all hydrocarbon vapors. An alarm may be triggered by the use of chemicals such as cleaners, paint, polish, lacquer, gasoline, silicone, silicone spray, or other harsh chemicals. The sensors will also detect hydrogen fumes from an overcharged battery. If a sensor sends an alarm, but no gas fumes are present, check for recent use of chemicals or a battery charger.

Natural Gas Vehicles

NOTICE

Silicone-based chemicals and cleaners will permanently disable the sensors. When cleaning the vehicle, cover the sensors with a plastic covering. Keep the sensors covered until the area has been cleared of any cleaning fumes.

Harsh chemicals, including some high alcohol cotenant washer fluids, and extremely high temperatures may damage the sensor.

Puncture of or damage to the seal located inside the sensor housing will significantly shorten the sensor life.

Frequent exposure to high concentrations of gas will accelerate sensor deterioration.

Overhead Console

The overhead console consists of an alarm panel on the right side and the control module on the left side.

The alarm panel has a green light, a red light, a buzzer, and a sensor. See [Fig. 25.6](#). It is located within view from outside of the vehicle. The large green light is continuously illuminated during normal operating conditions.

Before entering the vehicle, always verify that the green light is illuminated. If the green light is not illuminated, do not enter the vehicle. Complete the alarm procedure previously outlined.

The alarm panel meets the California Highway Patrol Title 13-2008 and NFPA 52 2010 requirements. All drivers and technicians using it should be trained regarding the red and green lights, and the audible warning.

The control module, located on the center of the overhead console, contains the status lights and control buttons for the system. The areas that the sensors monitor are defined as Zone 1 (cab), Zone 2 (engine compartment), and Zone 3 (sleeper, if equipped). The control module has lights assigned to each zone that will illuminate if a sensor detects a trace level leak (between 20% and 30% LFL), a significant level leak (above 50% LFL), or if a sensor is disconnected or malfunctioning.

- **Trace Level:** If either sensor detects gas fumes at a concentration greater than 20% to 30% LFL (1% gas in air by volume), the amber light next to the *Trace* indicator for that zone will

flash. There is no buzzer alarm for a trace level detection, and the large green light on the alarm panel will remain illuminated.

- **Significant Level:** If either sensor detects gas fumes at a concentration greater than 50% to 60% LFL (2.5% gas in air by volume), the small red light next to the *SIGNIFICANT* indicator for that zone will flash. After approximately 15 seconds, the large green light on the alarm panel will switch off, the red light will illuminate, and the buzzer will sound. All alarm indicators will remain on as long as fumes are detected.
- **Sensor Fault:** If the system detects that either of the sensors has been disconnected or has malfunctioned, an amber light next to the *Sensor Fault* indicator for that zone will illuminate.

The control module also has buttons used to test or reset the the control module after an alarm. Red lights next to each button indicate when they are engaged.

- **Shutdown Reset:** If an alarm has been activated and the *Relay Engaged* light is illuminated, the *Shutdown Reset* button will reset the internal relay. Press the *Shutdown Reset* button only after the gas has cleared, the buzzer has turned off, and the alarm panel light has returned to green.
- **Push To Silence:** If an alarm has been activated, the *Push To Silence* button will silence the buzzer.

See [Table 25.2](#) for the functions of all lights and buttons on the overhead console.

Testing

Daimler Trucks North America strongly recommends that all operators follow California Code of Regulations (CCR) inspection requirements, regardless of where the vehicle is operated. Per Title 13 CCR § 935 (2), gas detection systems should be tested three times per calendar year at equal intervals. The testing procedure should simulate the same operating environment in which the vehicle is used, with the same gaseous fuel.

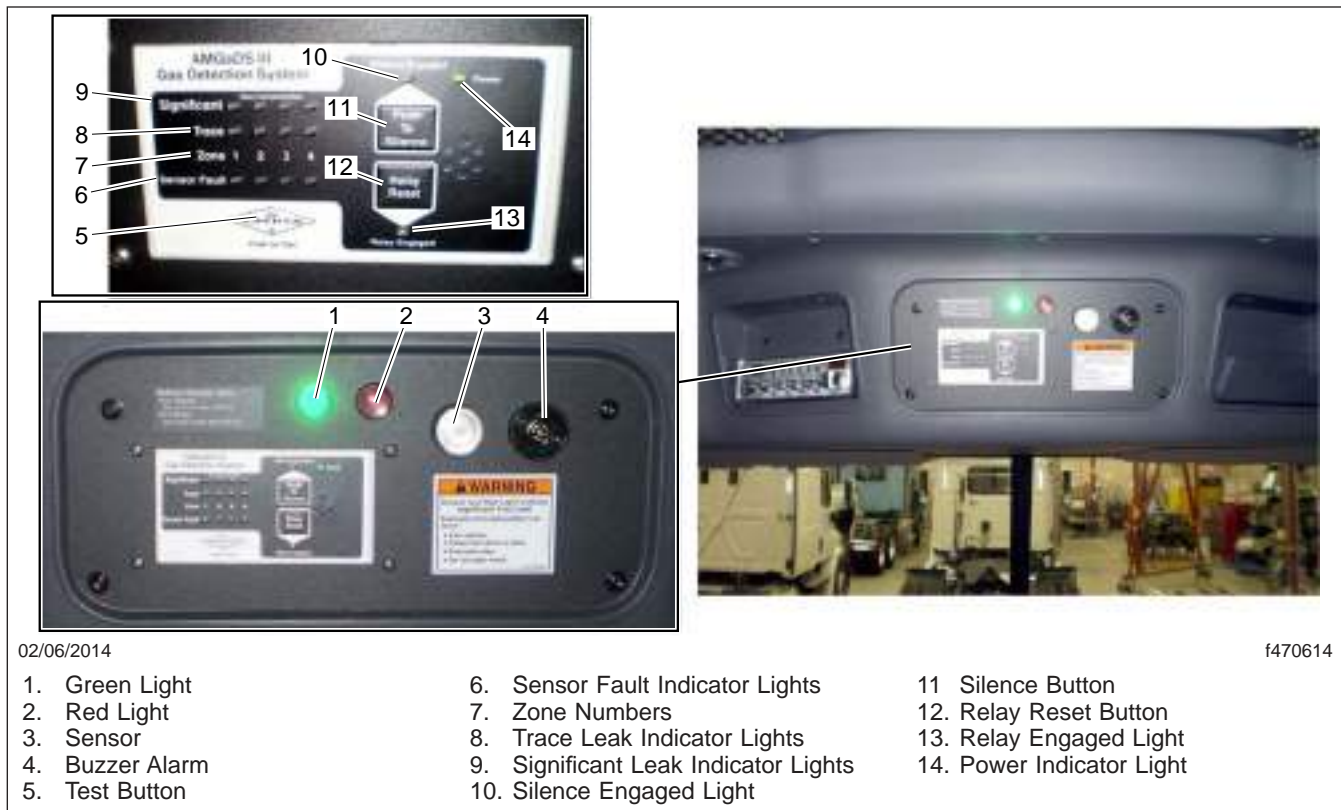

02/06/2014

f470614

- | | | |
|-----------------|--------------------------------------|---------------------------|
| 1. Green Light | 6. Sensor Fault Indicator Lights | 11. Silence Button |
| 2. Red Light | 7. Zone Numbers | 12. Relay Reset Button |
| 3. Sensor | 8. Trace Leak Indicator Lights | 13. Relay Engaged Light |
| 4. Buzzer Alarm | 9. Significant Leak Indicator Lights | 14. Power Indicator Light |
| 5. Test Button | 10. Silence Engaged Light | |

Fig. 25.6, AMGADS III Overhead Console

| Control Module Functions | | | |
|--------------------------------------|-------------------|---------------------------------------|---|
| Item | Display | Function | Action Required |
| Green Power Light | Illuminated | System is on. | None required. |
| | Unlit | Detection system is not functioning. | Ensure the batteries are connected and replace any blown fuses. If the gas detection system is still not functioning, replace the system immediately. |
| SIGNIFICANT Gas Concentration Lights | Red (illuminated) | Dangerous gas concentration detected. | Suspend vehicle operation immediately and follow alarm procedures. |
| Trace Gas Concentration Lights | Amber (flashing) | Minor gas concentration detected. | Suspend vehicle operation immediately and follow alarm procedures. |
| Sensor Fault Lights | Off | Sensor is functioning properly. | None required. |
| | On | Sensor has malfunctioned. | Replace the sensor immediately. |

Natural Gas Vehicles

| Control Module Functions | | | |
|--------------------------|---------|--|---|
| Item | Display | Function | Action Required |
| Shutdown Reset Button | — | Resets the system after an alarm activation. | Press to reset the system only after the gas has cleared, the buzzer has turned off, and the alarm panel light has returned to green. |
| Relay Engaged Light | On | Relay is engaged and test or alarm is being cleared. | Press the <i>Shutdown Reset</i> button. |
| | Off | Normal condition. | None required. |
| Test Button | — | Tests the overhead console operation and circuitry. | Press and hold for one minute to activate a test of all overhead console components. |
| Silence Button | — | Silences the alarm buzzer. | Press to silence the alarm buzzer. |
| Silence Engaged Light | On | Indicates the buzzer is active but silenced. | Suspend vehicle operation immediately and follow alarm procedures. |
| | Off | Normal condition. | None required. |

Table 25.2, Control Module Functions

Test results validating the performance of the gas detection system within the parameters established by the component manufacturer and NFPA 52 2010 should be maintained as a permanent part of the vehicle service records. Use of alcohol, propane, and other harsh liquids or gases are not acceptable methods for testing.

Always test the system and sensors after any component has been replaced, or if the vehicle has been involved in an accident or fire. Ensure that the gas detection system is wired directly to the battery.

It is recommended that the highest level of safety validation be utilized if there are multiple validation requirements in the state or locality where the vehicle is operated or domiciled.

Overhead Console Test

Press and hold the *Push To Test* button for one minute. The system will proceed with a self-diagnostic test that will include illumination of the *Trace* and *Significant* gas concentration lights, and the sensor fault lights. Verify the large red light and buzzer activate, and that all lights illuminate or flash to ensure that all bulbs are operational.

Sensor Test

The gas detection system sensors must be tested using qualified test gas, which can be purchased as part of a test kit. Testing with alcohol or heavy gases

such as butane or propane does not satisfy CCR § 935 (2) or NFPA 52 regulations.

Expose each sensor to qualified test gas for at least 30 seconds. The system will proceed through the alarm procedure consistent with a significant leak and the buzzer will sound after approximately 15 seconds. If a sensor fails to respond after exposure to the test gas, replace the sensor.

Natural Gas Engine Starting

NOTE: Before starting the engine, read [Chapter 4](#) for detailed information on how to read the instruments and [Chapter 5](#) for detailed information on how to operate the controls. Read the operating instructions in the engine manufacturer's operation manual before starting the engine.

1. Before engine start-up, complete the engine pre-trip and post-trip inspections and maintenance procedures in [Chapter 21](#).
2. Ensure the fuel shutoff valve is open.
3. Set the parking brake.
4. Ensure that the transmission shift control is in Neutral (N), Park (P), or the Park Brake (PB) position.

- Without starting the engine, turn the ignition switch to the ON position (Fig. 25.7). The electronic gauges on the instrumentation control unit (ICU) will complete a full sweep of their dials, the warning and indicator lights will illuminate, and the buzzer will sound for three seconds.

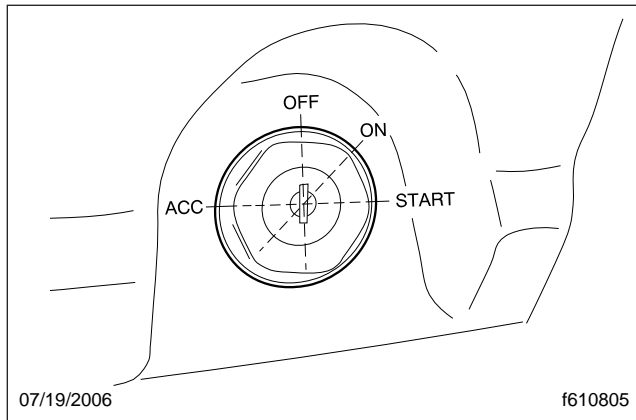

Fig. 25.7, Ignition Switch Positions

- Turn the ignition switch to the START position.
Press down on the clutch pedal, if equipped, but do not press down on the accelerator pedal.
Release the key the moment the engine starts.
- Bring the engine up to operating speed gradually as it warms up and develops stable oil pressure.
If the vehicle has not been operated previously in a 24-hour period, allow the vehicle to idle for five minutes.

NOTICE

Do not rev the engine if the oil pressure gauge indicates no oil pressure. Shut down the engine within approximately ten seconds to avoid engine damage.

- Check the oil pressure gauge for any drop in lubricating oil pressure or mechanical malfunction in the lubricating oil system.

Major Repairs and Replacement of Natural Gas Components

IMPORTANT: All repairs to natural gas system and components must be performed by certified technicians.

If a natural-gas-fueled vehicle is involved in an accident, remove the fuel tank or cylinders from service and have them inspected by a qualified technician. Replace any leaking or damaged fuel tanks/cylinders and fuel lines; repair or replace leaking or damaged fittings. Install parts and components in accordance with the manufacturer's instructions.

26

Specifications

| | |
|-----------------------------|------|
| Fuses and Relays | 26.1 |
| Replacement Bulbs | 26.3 |
| Fluids and Lubricants | 26.4 |

Specifications

Fuses and Relays



This vehicle may be equipped with a roof-mounted Citizens' Band (CB) antenna. Operation of an amplified CB radio with output power greater than FCC limits (4W AM/12W SSB) is illegal, and may expose vehicle occupants to radio frequency (RF) radiation that exceeds FCC maximum permissible RF exposure limits. Vehicle occupants with electronic medical devices should consult the device manufacturer's user manual or a physician for information on RF radiation exposure limit guidelines.

| SAM Cab Fuses | | |
|---------------|-----------------------|-----|
| Part | Name | AMP |
| F1 | Power FD Spare 1 & 3 | 30 |
| F2 | Cab/Slpr HVAC Ctrl | 15 |
| | Trans Shift Pnl | |
| F3 | Power FD Spare 2 & 4 | 30 |
| F4 | MSF | 15 |
| F5 | OBD J1939 | 10 |
| | OBD DCDI | |
| F6 | Dash Power Recp 1 | 15 |
| F7 | Dash Power Recp 2 | 15 |
| F8 | Phone/Radio | 15 |
| F9 | Amplifier Power | 20 |
| F10 | Cab HVAC Motor | 30 |
| F11 | Sleeper HVAC Motor | 30 |
| F12 | Door Controls, L | 20 |
| F13 | Door Lock | 20 |
| | Coll Warn Sys | |
| F14 | Fleet Mgm Sys | 25 |
| | CB | |
| F15 | Sleeper Power Recp 3 | 20 |
| F16A | Aux Cab Heater Enable | 3 |
| F16B | Aux Coolant Heater | 20 |
| F17 | Power Recp 4 | 20 |
| F18 | GPS | 15 |
| | Tire Press Monitor | |
| | Antitheft Warn | |
| | AuxiliaryTelematics | |
| F19 | Heated Seat | 20 |

| SAM Cab Fuses | | |
|---------------|---|------|
| Part | Name | AMP |
| F20 | CGW | 2 |
| F21 | Area Light | 15 |
| F22 | ICU | 5 |
| | Horn Switch | |
| F23 | GPS | 15 |
| | Driver Info Sys | |
| | Fleet Mgmt Sys | |
| | Pyrometer, Axle Temp, Eng Oil Temp Gauges | |
| F24 | Diagnostic Conn | 7.5* |
| | ICU | |
| F25 | Trans Temp Gauge/Shift Select | 10† |
| | Phone | |
| | Collision Warn Sys | |
| F26 | SRS Airbags | 5 |
| F27 | Mirror Heat, L | 10 |
| F28 | Mirror Heat, R | 10 |
| F29 | SAM Relay Coils | 3 |
| F30 | Power Recp 6 | 20 |
| F31 | Power Recp 5 | 20 |
| F32 | Power FD Spare 5 & 6 | 25 |
| F33 | Spotlight | 20 |
| F34 | Baggage Comp Lamp | 3 |
| F35 | Dome Lamp | 15 |
| F36 | Aux Circulation Fan | 15 |
| | Road Lamps | |
| F37 | Clock (cab & sleeper) | 15 |
| | Driver Info Sys | |
| | CD Player | |
| | Keyless Entry | |
| F38 | Door Controls, R | 20 |
| F39 | Power Window, R | 15 |
| F40 | Power Window, L | 15 |
| F41 | Aux Mirror Heat | 10 |

* F24 value on assemblies -005 and lower is 10 amps.

† F25 value on assemblies -005 and lower is 7.5 amps.

Table 26.1, SAM Cab Fuses

| SAM Cab Relays | | |
|-----------------------|---|--------|
| Position | Function | Source |
| BR21 | Power FD Spare 1 & 3 | BAT |
| | Dash Power Recp 1 | |
| BR22 | Power FD Spare 2 & 4 | BAT |
| | Slpr Power Recp 3 | |
| R3 | Heated Seats | IGN |
| BR23 | Dash Power Recp2 | BAT |
| | Fleet Mgmt Sys | |
| | CB | |
| | Aux Cab Heater | |
| R7 | Aux Coolant Heater | IGN |
| | GPS | |
| | Driver Info Sys | |
| | Fleet Mgmt Sys | |
| R8 | Pyrometer, Axle Temp, Eng Oil Temp Gauges | IGN |
| | Diagnostic Conn | |
| | ICU | |
| | Trans Temp/Shift Select | |
| | Phone | |
| R9 | Coll Warn Sys | ACC |
| R10 | SRS Airbags | ACC |
| BR24 | Amplifier Power | BAT |
| | Mirror Heat (L, R, & Aux) | |
| | Power Recp6 | |
| | Area Lighting | |
| BR25 | Baggage Comp Lamp | BAT |
| | Dome Lamp | |
| | Power Recp 4 & 5 | |
| R15 | Aux Circulation Fan | ACC |
| | Reading Lamp | |
| | Power Windows | |

Table 26.2, SAM Cab Relays

| SAM Chassis Fuses | | |
|--------------------------|-------------------------------|-----|
| Part | Name | AMP |
| F1 | Elec Air Process. Unit (EAPU) | 20 |
| F2 | Fuel/Water Separator Heat | 20 |
| F3 | ABS Bat 1 | 20 |
| F4 | ABS Bat 2 | 10 |
| F5 | Trailer Left-Turn Lamp | 20 |
| F6 | ABS | 15 |
| F7 | EAPU/WIF | 10 |
| | Rear Camera | |
| F8 | Trailer Right-Turn Lamp | 20 |
| F9 | Trailer Marker Lamps | 30 |
| F10 | SAM Relay Coils | 5 |
| F11 | Trailer ABS | 30 |
| F12 | Trailer Stop Lamps | 30 |
| F13 | Trailer Tail Lamps | 20 |
| F14 | Trailer Power | 30 |

Table 26.3, SAM Chassis Fuses

| SAM Chassis Relays | |
|---------------------------|---------------------------|
| Position | Function |
| R1 | Fuel/Water Separator Heat |
| R2 | Trailer Left-Turn Lamp |
| R3 | ABS |
| | EAPU/WIM |
| R4 | Rear Camera |
| | Trailer Right-Turn Lamp |
| R5 | Trailer Marker Lamps |
| R6 | Trailer ABS |
| R7 | Trailer Stop Lamps |
| R8 | Trailer Power |
| R9 | Trailer Tail Lamps |

Table 26.4, SAM Chassis Relays

| MEGA Fuse Junction Block (MFJB) Fuses, EPA07 Only | | |
|--|-----------------------------|-----|
| Part | Name | AMP |
| F1 | Powertrain PDM | 175 |
| F2 | SAM Cab | 175 |
| F3 | SAM Chassis | 125 |
| F4 | Chassis-Mounted Trailer PDM | 125 |

Specifications

| MEGA Fuse Junction Block (MFJB) Fuses, EPA07 Only | | |
|---|----------|-----|
| Part | Name | AMP |
| F5 | Inverter | 200 |

Table 26.5, MEGA Fuse Junction Block (MFJB) Fuses, EPA07 Only

| Powernet Distribution Box (PNDB) Fuses, EPA10 and Newer | | |
|---|-------------------------------|-----|
| Fuse | Function | AMP |
| A | Aftertreatment Control Module | 30 |
| B | Emergency Power | 20 |
| C | Radio/Clock | 5 |
| D | Alternator Remote Sense | 5 |
| 1 | Powertrain PDM | 175 |
| 2 | SAM Chassis | 125 |
| 3 | SAM Cab | 175 |

Table 26.6, Powernet Distribution Box (PNDB) Fuses, EPA10 and Newer

| Trailer PDM Fuses and Relays | | |
|------------------------------|----------------------|-----|
| Position | Function | AMP |
| F1 | Trailer Power Fuse | 30 |
| F2 | Taillight Fuse | 30 |
| F3 | Left-Turn Lamp Fuse | 20 |
| F4 | Right-Turn Lamp Fuse | 20 |
| F5 | Marker Lamp Fuse | 30 |
| F6 | Stop Lamp Fuse | 30 |
| R1 | Taillight Relay | |
| R2 | Right-Turn Relay | |
| R3 | Stop Lamp Relay | |
| R4 | Trailer Power Relay | |
| R5 | Left-Turn Relay | |
| R6 | Marker Lamp Relay | |

Table 26.7, Trailer PDM Fuses and Relays

Replacement Bulbs

| Replacement Bulbs | |
|---|---------------------|
| Lamp Assembly | Replacement Bulb |
| Headlight Hi/Low Beam, Fog light, Driving Light | WEE 12362LLBA (H11) |
| Turn/Marker Lamp (in headlight assy) | GE 3457 |
| Incandescent Auxiliary Turn (on fender) | GE 2058U |
| Integral Stop/Tail/Backup Lights | GE 1157/GE 1156 |
| Utility Light | WEE 199 |
| Cab Dome Lamp, Clear, Outboard | GN12 BUL 050 R5WC |
| Cab Dome Lamp, Clear, Inboard | GN12 BUL 049 R10W |
| Cab Dome Lamp (Red) | GN12 BUL 050 R5WR |
| Sleeper Reading Lamp | GRLSAP270 |
| Sleeper Dome Lamp | GRLBUL049R10W |
| Sleeper Writing Desk Lamp | GRLBUL027578 |
| Sleeper Bunk Lamp | GRLBUL0142112 |
| Footwell Lamp (Red) | GRLBUL042W5W |

Table 26.8, Replacement Bulbs

Fluids and Lubricants

| Type | Approved Fluid or Lubricant | |
|---------------------------------|--|-----------------------------------|
| Engine Oil* | Engines compliant with EPA07 or newer regulations: Engine lube oil with a sulfated ash level less than 1.0 wt %; currently referred to as CJ-4 oil. | |
| Fuel† | Engines compliant with EPA07 or newer regulations: Ultralow-sulfur diesel (ULSD) with 15 ppm sulfur content or less, based on ASTM D2622 test procedure. | |
| Power Steering Fluid | ATF must meet TES 389 or Dexron III specifications | |
| Hydraulic Clutch Fluid | DOT 4 | |
| Manual Transmission Lubricant‡§ | MobilTrans SHC 50 (RN 2952 E-5), SAE 50W | |
| | Synthetic transmission lubricant approved by Eaton, SAE 50W | |
| Antifreeze | Caterpillar Diesel Engine Antifreeze/Coolant. Contains supplement additives. Available as a premixed solution. | |
| | Detroit™ Power Cool, premixed solution with supplement additives. | |
| | Old World Industries, Fleet Charge™, with supplement additives. | |
| Drive Axle Lubricant | Recommended SAE Viscosity Grade | Ambient Temperature Range |
| | 75W | -40°F to -15°F (-40°C to -26°C) |
| | 75W—80 | -40°F to 80°F (-40°C to 27°C) |
| | 75W—90 | -40°F to 100°F (-40°C to 38°C) |
| | 75W—140 | -40°F and above (-40°C and above) |
| | 80W—90 | -15°F to 100°F (-26°C to 38°C) |
| 80W—140 | 10°F and above (-12°C and above) | |

* See the engine manufacturer's manual for specifications.

† See the engine manufacturer's manual for specifications.

‡ Do not mix types or brands of fluid. Multi-weight and extreme-pressure gear fluids are not recommended.

§ Call 1-800-826-4357 for a complete list of Eaton approved lubricants.

Table 26.9, Approved Fluids and Lubricants

Index

| Subject | Page |
|--|------|
| A | |
| Accessory Heaters | 8.5 |
| Espar Heater | 8.6 |
| Webasto Heater | 8.7 |
| Adjustable Steering Column Controls | 5.20 |
| Adjusting Headlight Aim | 23.1 |
| Air Brake System | 13.1 |
| Automatic Slack Adjusters | 13.3 |
| Brake System Components | 13.1 |
| Brake System General Information | 13.1 |
| Brake System Operation | 13.1 |
| Air-Suspension Dump Valve | 19.1 |
| B | |
| Back-of-Cab Access | 2.4 |
| Climbing Down from Back- of-Cab | 2.5 |
| Entering Back-of-Cab | 2.5 |
| C | |
| Cab Amenities | 9.1 |
| Cup Holders | 9.1 |
| Lighting | 9.1 |
| Power Outlets | 9.1 |
| Radio and CB | 9.2 |
| Storage | 9.2 |
| Cab Climate Control Panel | 8.1 |
| Fan Switch | 8.1 |
| Mode Control Switch | 8.2 |
| Temperature Control Switch | 8.1 |
| Cab Door Locks and Handles | 2.1 |
| Cab Washing and Polishing | 22.1 |
| Cab-to-Sleeper Access | 2.3 |
| Canadian Motor Vehicle Safety Standard Labels | 1.1 |
| Care of Chrome Parts | 22.1 |
| Care of Exterior Lights | 22.1 |
| Care of Fiberglass Parts | 22.1 |
| Cascadia 2.0 High-Back Seat | 7.2 |
| Armrest Angle | 7.3 |
| Bottom Cushion Extension | 7.3 |
| Fore/Aft Isolator | 7.2 |
| Height Adjustment | 7.2 |
| Lumbar Support | 7.2 |
| Recline | 7.2 |
| Seat Fore/Aft Slide | 7.3 |
| Seat Heating/Ventilation | 7.2 |

| Subject | Page |
|---|------|
| Seat Tilt | 7.3 |
| Shock Absorber Adjustment | 7.2 |
| Cascadia High-Back Seat | 7.3 |
| Backrest Tilt | 7.3 |
| Bottom Cushion Extension | 7.3 |
| Fore/Aft Isolator | 7.3 |
| Fore/Aft Seat Slide | 7.3 |
| Front Cushion Height | 7.3 |
| Heater | 7.4 |
| Height Adjustment | 7.3 |
| Lumbar Support | 7.3 |
| Rear Cushion Height | 7.3 |
| Shock Absorber | 7.3 |
| Checking Headlight Aim | 23.1 |
| Checklists | 20.1 |
| Daily Pretrip Inspection Checklists | 20.1 |
| Monthly Post-trip Inspection Checklists | 20.2 |
| Weekly Post-trip Inspection Checklist | 20.2 |
| Climate Controls | 5.17 |
| Cab Climate Control | 5.17 |
| Sleeper Climate Control | 5.18 |
| Clutch | 14.5 |
| Clutch Maintenance | 14.7 |
| Clutch Operation | 14.6 |
| General Information | 14.5 |
| Component GWR Label | 1.1 |
| Component Information Label | 1.1 |
| Cruise Control | 5.11 |
| Cruise Control ("CC") Limiter | 5.13 |
| Descent Control and Deceleration Modes, Detroit™ Automated Transmissions | 5.13 |
| Run Smart Predictive Cruise™ | 5.12 |
| D | |
| Daily Pretrip Inspection and Maintenance | 21.1 |
| Cab Inspection | 21.5 |
| Engine Compartment Inspection | 21.4 |
| Natural Gas Fuel System Inspection | 21.8 |
| Saddle Tank Areas Inspection | 21.4 |
| Suspension and Slack Adjuster Inspection | 21.1 |
| Wheel and Tire Inspection | 21.2 |

| Subject | Page | Subject | Page |
|---|------|--|-------|
| Dashboard Care | 22.2 | General Information, Eaton Fuller Splitter and Range-Shift | 14.1 |
| Dash-Mounted Brake Controls | 5.14 | Operation, Eaton Fuller Splitter and Range-Shift | 14.1 |
| Antilock Braking System | 5.15 | Eaton Fuller AutoShift Automated Transmissions | 15.11 |
| Parking Brake Control Valve | 5.14 | General Information, | |
| Trailer Air Supply Valve | 5.14 | AutoShift | 15.11 |
| Trailer Brake Lever | 5.15 | Operation, AutoShift with SmartShift | 15.11 |
| Detroit™ Automated Transmissions | 15.1 | Eaton Fuller UltraShift PLUS | 15.14 |
| Clutch Abuse Protection | 15.4 | Auto Neutral | 15.17 |
| Creep Mode | 15.3 | Auto Start Gear Selection and Override | 15.17 |
| Detroit™ Multifunction Control | 15.1 | Automatic Mode (AUTO) | 15.14 |
| Driving Modes | 15.2 | Automatic Traction Control | 15.17 |
| eCoast | 15.3 | Clutch Abuse Protection | 15.15 |
| Engine Overspeed Alerts | 15.4 | Coasting | 15.17 |
| Gear Display Window | 15.2 | Creep Mode | 15.16 |
| Low Transmission Air Warning | 15.4 | Engine Overspeed Protection | 15.16 |
| Power Up and Shift into Gear | 15.2 | Hill Start Aid | 15.16 |
| Selected Gear | 15.3 | Load-Based Shifting | 15.17 |
| Suggested Shift | 15.3 | Low (L) | 15.15 |
| Diesel Exhaust Fluid and Tank, EPA10 and Newer Engines | 12.3 | Manual Mode (MAN) | 15.15 |
| DEF Tank | 12.4 | Power Down | 15.14 |
| DEF Warnings and Engine Limits | 12.5 | Power Up | 15.14 |
| Diesel Exhaust Fluid | 12.3 | Reverse (R) | 15.14 |
| Fuel/DEF Gauge | 12.4 | Shuttle Shifting | 15.16 |
| Differential Locks | 16.1 | Skip Shifting | 15.17 |
| Driver-Controlled Differential Lock (DCDL) | 16.1 | Eaton Fuller UltraShift | 15.6 |
| Single Drive Axles with Traction Equalizer | 16.2 | General Information, | |
| Tandem Drive Axles with Interaxle Differential Lock | 16.1 | UltraShift DM | 15.6 |
| Driver Message Center | 4.11 | Operation, UltraShift DM | 15.6 |
| ICU3/ICU4 | 4.11 | Ultrasht Diagnostic | 15.10 |
| ICU4Me | 4.19 | Electrical Power Distribution | 3.1 |
| ICU4M | 4.13 | Cab Load Disconnect Switch | 3.3 |
| | | Circuit Protection Features | 3.1 |
| E | | MEGA Fuse Junction Block, EPA07 | 3.1 |
| Eaton Fuller 10-Speed Range-Shift Transmissions | 14.4 | Power Distribution Modules | 3.1 |
| General Information, Eaton Fuller Range-Shift | 14.4 | Powernet Distribution Box, EPA10 and Newer | 3.1 |
| Operation, Eaton Fuller Range-Shift | 14.4 | Emergency Filter Replacement, Davco | 24.1 |
| Eaton Fuller 13-Speed and 18-Speed Splitter and Range-Shift Transmissions | 14.1 | Emergency Kit, Optional | 24.1 |
| | | Emergency Power Supply | 3.3 |
| | | SAM Cab Fault | 3.4 |
| | | SAM Chassis Fault | 3.4 |
| | | Emergency Starting With Jumper Cables | 24.2 |
| | | Emissions Labels | 1.1 |

Index

| Subject | Page |
|--|------|
| Aftertreatment System Indicators Label | 1.1 |
| Certified Clean Idle Label | 1.4 |
| EPA Noise Emission Control Label | 1.3 |
| Vehicle Emission Control Information Label | 1.4 |
| Engine Brake | 13.5 |
| Engine Brake Operation | 13.5 |
| Engine Idle Limiting | 11.2 |
| California Engine Idle Limiting | 11.2 |
| Idle Shutdown Timer | 11.2 |
| Engine Operation | 10.2 |
| Cold-Weather Operation | 10.3 |
| Engine Break-In | 10.3 |
| High-Altitude Operation | 10.4 |
| Normal Operation | 10.3 |
| Safety and Environmental Considerations | 10.2 |
| Engine Protection—Warning and Shutdown | 11.1 |
| Engine Shutdown | 10.4 |
| Engine Starting | 10.1 |
| Cold-Weather Starting | 10.2 |
| Starting After Extended Shutdown | 10.2 |
| Enhanced Stability Control | 6.13 |
| EPA-Regulated Emissions | |
| Aftertreatment Systems | 12.1 |
| ATS Warning Lamps | 12.3 |
| EPA07 Engines | 12.1 |
| EPA10 and Newer Engines | 12.1 |
| Maintenance | 12.3 |
| Regeneration | 12.2 |

F

| | |
|--|------|
| Federal Motor Vehicle Safety Standard Labels | 1.1 |
| Fifth Wheel Coupling | 18.1 |
| Fontaine and Holland Fifth Wheels Coupling | 18.1 |
| Jost Fifth Wheel Coupling | 18.3 |
| Fifth Wheel Slide | 18.7 |
| Air Slide Operation | 18.9 |
| Manual Slide Operation | 18.7 |
| Fifth Wheel Uncoupling | 18.4 |
| Air-Actuated Uncoupling | 18.5 |
| Manual Uncoupling | 18.4 |
| Fifth Wheels, General Information | 18.1 |
| Air-Suspension Dump Valve | 18.1 |

| Subject | Page |
|---------------------------------------|------|
| Fifth Wheel Lubrication | 18.1 |
| Fire Extinguisher | 24.1 |
| Fire in the Cab | 24.7 |
| In Case of a Cab Fire | 24.7 |
| Fluids Added | 20.2 |
| Fluids and Lubricants | 26.4 |
| Freightliner SmartShift Shift Control | 15.5 |
| General Information, SmartShift | 15.5 |
| Fuses and Relays | 26.1 |

G

| | |
|---|------|
| Grab Handles and Access Steps | 2.1 |
| Entering the Driver Side | 2.2 |
| Entering the Passenger Side | 2.2 |
| Exiting the Driver Side | 2.2 |
| Exiting the Passenger Side | 2.2 |
| Greenhouse Gas Emissions and Fuel Consumption Standards | 12.1 |

H

| | |
|--------------------------|------|
| Hazard Warning Lights | 24.1 |
| Holland Trailer Coupling | 19.1 |
| General Information | 19.1 |
| Operation | 19.1 |
| Hood Opening and Closing | 2.5 |
| To Return the Hood | 2.5 |
| To Tilt the Hood | 2.5 |
| Horn Controls | 5.7 |
| Air Horn | 5.7 |
| Electric Horn | 5.7 |

I

| | |
|-----------------------------------|------|
| Ignition Switch and Key | 5.1 |
| Instrumentation Control Units | 4.1 |
| Audible Alerts | 4.2 |
| Ignition Sequence | 4.1 |
| Instruments | 4.7 |
| Air Intake Restriction Gauge | 4.7 |
| Application Air Pressure Gauge | 4.8 |
| Coolant Temperature Gauge | 4.9 |
| Drive Axle Oil Temperature Gauges | 4.9 |
| Engine Oil Pressure Gauge | 4.9 |
| Engine Oil Temperature Gauge | 4.10 |

| Subject | Page | Subject | Page |
|---|-------|---|------|
| Fuel Gauge, Pre-EPA10 | 4.10 | LNG Vehicle Fueling | 25.5 |
| Fuel/Diesel Exhaust Fluid (DEF) Gauge, EPA10 and Newer | 4.10 | Natural Gas Vehicles, General Information | 25.1 |
| Primary and Secondary Air Pressure Gauges | 4.10 | Natural Gas Vehicles, Safety Precautions | 25.1 |
| Speedometer | 4.11 | In Case of Emergency | 25.3 |
| Tachometer | 4.11 | O | |
| Transmission Fluid Temperature Gauge | 4.11 | OnGuard™ Collision Safety System | 6.7 |
| Turbocharger Boost Pressure Gauge | 4.11 | Adaptive Cruise Control (ACC) | 6.8 |
| Voltmeter | 4.11 | Additional Features | 6.10 |
| L | | Collision Mitigation System (CMS) | 6.9 |
| Lane Departure Warning Controls | 6.10 | Collision Warning System (CWS) | 6.7 |
| Lighting Controls | 5.2 | Error Screens | 6.9 |
| Exterior Lighting Controls | 5.2 | OnGuard Display Unit | 6.7 |
| Interior Lighting Controls | 5.6 | Optimized Idle® | 11.2 |
| M | | Overhead Instrument Panel | 4.24 |
| Major Repairs and Replacement of Natural Gas Components | 25.10 | P | |
| Meritor WABCO® Antilock Braking System | 13.3 | ParkSmart™ HVAC System | 8.3 |
| Automatic Traction Control | 13.4 | Standard Vehicle Configuration | 8.3 |
| ECAS Automatic Load Transfer (ECAS only) | 13.4 | Vehicles with Detroit Diesel Optimized Idle | 8.5 |
| Trailer ABS Compatibility | 13.4 | Periodic Inspections and Maintenance, General Information | 20.1 |
| Mirrors | 9.1 | Power Steering System General Information | 17.1 |
| Monthly Post-Trip Inspections and Maintenance | 21.13 | Power Steering Systems | 17.1 |
| Brake Component Inspection | 21.13 | Rack and Pinion Steering System | 17.1 |
| Engine Compartment Inspection and Adjustments | 21.15 | Steering Gear System | 17.1 |
| Saddle Tank Areas Inspection | 21.14 | Power Takeoff (PTO) Governor | 11.2 |
| N | | Powertrain Controls | 5.7 |
| Natural Gas Detection System | 25.5 | Aftertreatment System Regen Switches | 5.7 |
| Alarm Procedure | 25.5 | Axle Switches | 5.8 |
| Overhead Console | 25.7 | Engine Brake Switch | 5.8 |
| Sensors | 25.6 | Engine Fan Switch | 5.9 |
| Testing | 25.7 | Hill Start Aid Override Switch | 5.9 |
| Natural Gas Engine Starting | 25.9 | PTO Switch | 5.9 |
| Natural Gas Fuel Tank Filling Procedures | 25.3 | Transmission Controls | 5.9 |
| CNG Vehicle Fueling | 25.3 | Preliminary Checks | 23.1 |
| | | Progressive Low Voltage Disconnect | 3.4 |

Index

| Subject | Page |
|--|------|
| R | |
| Replacement Bulbs | 26.3 |
| Roll Stability System | 6.11 |
| Hard-Braking Advisor | 6.13 |
| Roll Stability Advisor | 6.12 |
| Roll Stability Control | 6.12 |
| Trip/Leg Totals | 6.13 |
| RollTek Rollover Protection System | 7.9 |
| Identification | 7.9 |
| Inspection and Service | 7.11 |
| Operation | 7.9 |
| S | |
| Sears Atlas Seat | 7.4 |
| Armrest Angle | 7.5 |
| Backrest Tilt | 7.4 |
| Bottom Cushion Tilt | 7.5 |
| Fore/Aft Seat Slide | 7.4 |
| Isolator | 7.5 |
| Lumbar Support | 7.4 |
| Seat Extension | 7.5 |
| Suspension Inflation/Deflation | 7.5 |
| Seat Belts and Tether Belts | 7.5 |
| Seat Belt Inspection | 7.6 |
| Seat Belt Operation | 7.6 |
| Seat Controls | 5.19 |
| Seats, General Information | 7.1 |
| Sleeper Amenities | 9.2 |
| Baggage Compartment Doors | 9.2 |
| Lighting | 9.2 |
| Power Outlets | 9.2 |
| Sleeper Access Door | 9.2 |
| Sliding Side Window | 9.3 |
| Sleeper Climate Control Panel | 8.2 |
| Fan Switch | 8.2 |
| Temperature Control Switch | 8.3 |
| Sleeper Door | 2.3 |
| Sleeper Luggage Door | 2.4 |
| Steering Wheel Air Bag | 7.8 |
| Inspection and Service | 7.9 |
| Operation | 7.8 |
| Suspension/Trailer Connection Controls | 5.16 |
| Air Suspension Dump Control Switch | 5.16 |
| ECAS Remote Control Unit (ECAS only) | 5.16 |

| Subject | Page |
|--|-------|
| Fifth Wheel Slide Control Switch | 5.17 |
| Trailer Auxiliary Switch | 5.17 |
| T | |
| Towing | 24.4 |
| Front Towing Hookup | 24.5 |
| Rear Towing Hookup | 24.5 |
| Two-Speed Drive Axles | 16.2 |
| Axle Shift | 16.2 |
| V | |
| Velour Upholstery Cleaning | 22.3 |
| Chewing Gum or Wax | 22.3 |
| Grease and Oil-Based Stains | 22.3 |
| Mildew | 22.3 |
| Sugar and Water-Based Stains | 22.3 |
| Vinyl Upholstery Cleaning | 22.2 |
| Ball Point Ink | 22.3 |
| Chewing Gum | 22.2 |
| Miscellaneous | 22.3 |
| Nail Polish and Nail Polish Remover | 22.2 |
| Ordinary Dirt | 22.2 |
| Paint, Shoe Heel Marks | 22.2 |
| Shoe Polish | 22.2 |
| Sulfide Stains | 22.2 |
| Tars, Asphalts, and Creosote | 22.2 |
| VORAD VS-400 System | 6.1 |
| Collision Warning System | 6.4 |
| Driver Interface Unit | 6.1 |
| Failure Display Mode/Fault Codes | 6.6 |
| Maintenance | 6.6 |
| Side Object Detection | 6.5 |
| SmartCruise | 6.5 |
| Special Road Situations | 6.6 |
| W | |
| Warning and Indicator Lights | 4.3 |
| Engine Protection System | 4.7 |
| Weekly Post-Trip Inspections and Maintenance | 21.10 |
| Engine Compartment Inspection | 21.10 |
| Windows | 9.1 |
| Windshield Wiper/Washer Controls | 5.15 |