



Run Smart™

108SD and 114SD



Driver's Manual

Introduction

This manual provides information needed to operate and understand the vehicle and its components. More detailed information is contained in the *Owner's Warranty Information for North America* booklet, and in the vehicle's workshop and maintenance manuals.

Custom-built Freightliner vehicles are equipped with various chassis and cab components. Not all of the information contained in this manual applies to every vehicle. For details about components in your vehicle, refer to the chassis specification pages included in all new vehicles and to the vehicle specification decal, located inside the vehicle.

For your reference, keep this manual in the vehicle at all times.

IMPORTANT: Descriptions and specifications in this manual were in effect at the time of printing. Freightliner Trucks reserves the right to discontinue models and to change specifications or design at any time without notice and without incurring obligation. Descriptions and specifications contained in this publication provide no warranty, expressed or implied, and are subject to revisions and editions without notice.

Environmental Concerns and Recommendations

Whenever you see instructions in this manual to discard materials, you should first attempt to reclaim and recycle them. To preserve our environment, follow appropriate environmental rules and regulations when disposing of materials.

Event Data Recorder

This vehicle is equipped with one or more devices that record specific vehicle data. The type and amount of data recorded varies depending on how the vehicle is equipped (such as the brand of engine, if an air bag is installed, or if the vehicle features a collision avoidance system, etc.).

This vehicle is equipped with an event data recorder (EDR). The main purpose of an EDR is to record data in certain crash or near-crash situations, such as air bag deployment or hitting a road obstacle, that will assist in understanding how a vehicle's systems

performed. The EDR is designed to record data related to vehicle dynamics and safety systems for approximately 60 seconds. This data can help provide a better understanding of the circumstances in which crashes and injuries occur. Data recorded includes the following items:

- how various systems in the vehicle were operating
- engine system information
- how far (if at all) the driver was depressing the accelerator
- if the driver was depressing the brake pedal
- how fast the vehicle was traveling

NOTE: Data is not recorded by the EDR under normal driving conditions. Personal data such as name, gender, age, and crash location are not recorded. However, other parties such as law enforcement could combine the EDR data with the type of personally identifying data routinely acquired during a crash investigation.

To read data recorded by an EDR, special equipment is required, and access to the vehicle or the EDR is needed. In addition to the vehicle manufacturer, other parties that have the special equipment, such as law enforcement, can read the information if they have access to the vehicle or the EDR.

Emissions and Fuel Efficiency Compliance

This vehicle must be regularly inspected and maintained as indicated in the *108SD and 114SD Maintenance Manual*, and in the *Pre- and Post-Trip Inspections and Maintenance* chapter in this manual, in order to continue satisfactory performance and ensure coverage of the vehicle under the manufacturer's warranty. Many maintenance procedures ensure that the vehicle and engine continue to comply with applicable emissions standards. Maintenance procedures, using components engineered to comply with greenhouse gas emissions and fuel efficiency regulations, may be performed by an authorized Daimler Trucks North America dealer, an independent outlet, or the vehicle owner or operator.

The vehicle owner is responsible for determining the suitability of replacement components to maintain

Foreword

compliance with federal and local jurisdictional regulations. Components including, but not limited to, tires, cab/sleeper side extenders, chassis fairings, bumper, hood, vehicle speed limiters, and idle reduction timers are specifically designed and manufactured to exacting standards for regulatory fuel efficiency and greenhouse gas emissions compliance. It is important that these components are always replaced with components that meet or exceed the performance of the originally installed components.

hotline 1-800-333-0510, or contact Transport Canada by mail at: Transport Canada, ASFAD, Place de Ville Tower C, 330 Sparks Street, Ottawa, Ontario, Canada K1A 0N5.

For additional road safety information, please visit the Road Safety website at: www.tc.gc.ca/roadsafety.

Customer Assistance Center

Having trouble finding service? Call the Customer Assistance Center at 1-800-385-4357 or 1-800-FTL-HELP. Call night or day, weekdays or weekends, for dealer referral, vehicle information, breakdown coordination, or Fleetpack assistance. Our people are knowledgeable, professional, and committed to following through to help you keep your truck moving.

Reporting Safety Defects

If you believe that your vehicle has a defect which could cause a crash or could cause injury or death, you should immediately inform the National Highway Traffic Safety Administration (NHTSA) in addition to notifying Daimler Trucks North America LLC.

If NHTSA receives similar complaints, it may open an investigation, and if it finds that a safety defect exists in a group of vehicles, it may order a recall and remedy campaign. However, NHTSA cannot become involved in individual problems between you, your dealer, or Daimler Trucks North America LLC.

To contact NHTSA, you may call the Vehicle Safety Hotline toll-free at 1-888-327-4236 (TTY: 1-800-424-9153); go to www.safercar.gov; or write to: Administrator, NHTSA, 1200 New Jersey Avenue, SE, Washington, DC 20590. You can also obtain other information about motor vehicle safety from www.safercar.gov.

Canadian customers who wish to report a safety-related defect to Transport Canada, Defect Investigations and Recalls, may telephone the toll-free

© 2011-2015 Daimler Trucks North America LLC. All rights reserved. Daimler Trucks North America LLC is a Daimler company.

No part of this publication, in whole or part, may be translated, reproduced, stored in a retrieval system, or transmitted in any form by any means, electronic, mechanical, photocopying, recording, or otherwise, without the prior written permission of Daimler Trucks North America LLC. For additional information, please contact Daimler Trucks North America LLC, Service Systems and Documentation, P.O. Box 3849, Portland OR 97208-3849 U.S.A. or refer to www.Daimler-TrucksNorthAmerica.com and www.FreightlinerTrucks.com.

Contents

Chapter		Page
	Introduction, Environmental Concerns and Recommendations, Event Data Recorder, Emissions and Fuel Efficiency Compliance, Customer Assistance Center, Reporting Safety Defects	Foreword
1	Vehicle Identification	1.1
2	Vehicle Access	2.1
3	Electrical System	3.1
4	Instruments	4.1
5	Driver Controls	5.1
6	Seats and Restraints	6.1
7	Climate Control	7.1
8	Cab Features	8.1
9	Engine Starting, Operation, and Shutdown	9.1
10	Optional Engine Systems	10.1
11	Emissions and Fuel Efficiency	11.1
12	Brake Systems	12.1
13	Manual Transmissions and Clutch	13.1
14	Automated and Automatic Transmissions	14.1
15	Drive Axles	15.1
16	Steering System	16.1
17	Fifth Wheels	17.1
18	Trailer Couplings	18.1
19	Natural Gas Vehicle	19.1
20	Pre- and Post-Trip Checklists	20.1
21	Pre- and Post-Trip Inspections and Maintenance	21.1
22	Cab Appearance	22.1
23	Headlight Aiming	23.1
24	In an Emergency	24.1
	Index	I.1

1

Vehicle Identification

Component Information Label	1.1
Federal Motor Vehicle Safety Standard Labels	1.1
Canadian Motor Vehicle Safety Standard Labels	1.1
Component GWR Label	1.1
Emissions Labels	1.1

Vehicle Identification

Component Information Label

NOTE: Labels shown in this chapter are examples only. Actual specifications may vary from vehicle to vehicle.

The component information label lists the vehicle model, identification number, and major component models. It also lists the major assemblies and installations shown on the chassis specification sheet. One copy of the component information label is attached to the inside of the glove box; another copy is inside the rear cover of the *Owner's Warranty Information for North America* booklet. An illustration of the label is shown in [Fig. 1.1](#).

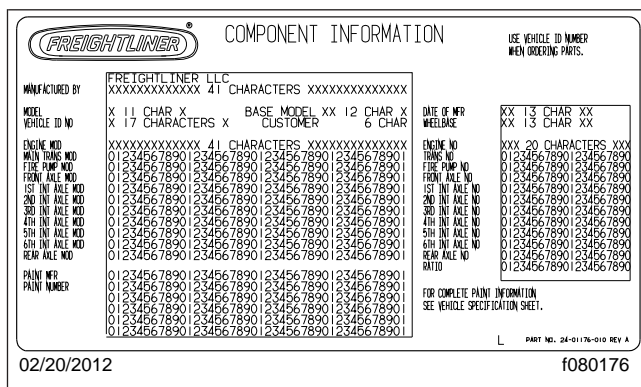

Fig. 1.1, Component Information Label

Federal Motor Vehicle Safety Standard Labels

NOTE: Due to the variety of Federal Motor Vehicle Safety Standard (FMVSS) certification requirements, not all of the labels shown will apply to your vehicle.

Tractors with or without fifth wheels purchased in the U.S. are marked as certified by means of an FMVSS certification label. See [Fig. 1.2](#). This label is attached to the driver-side B-pillar, as shown in [Fig. 1.3](#).

The tire and rim portion of the FMVSS certification label certifies suitable tire and rim combinations that can be installed on the vehicle, for the given gross axle weight rating. Tires and rims installed on the vehicle at the time of manufacture may have a higher load capacity than that certified by the tire and rim label. If the tires and rims currently on the vehicle have a lower load capacity than that shown on the

tire and rim label, then the tires and rims determine the load limitations on each of the axles.

Trucks built without a cargo body that are intended for service in the U.S. have an incomplete vehicle certification label attached by the final-stage manufacturer. See [Fig. 1.4](#). This label will be attached to the incomplete vehicle document included with the vehicle, and certifies that the vehicle conforms to all applicable FMVSS regulations in effect on the date of completion.

Canadian Motor Vehicle Safety Standard Labels

In Canada, tractors with fifth wheels are marked as certified by means of a statement of compliance label with the Canadian National Safety Mark attached to the driver-side door frame B-pillar. See [Fig. 1.5](#).

Trucks built without a cargo body and tractors built without a fifth wheel that are intended for service in Canada have an incomplete vehicle certification label attached to the driver-side B-pillar. After completion of the vehicle, a complete certification label must be attached by the final-stage manufacturer to certify that the vehicle conforms to all applicable Canada Motor Vehicle Safety Standard (CMVSS) regulations in effect on the date of completion.

Component GWR Label

The component GWR label is located on the passenger-side B-pillar. The label provides maximum GWR ratings for each component.

See [Fig. 1.6](#) for a typical component GWR label.

Emissions Labels

Aftertreatment System Indicators Label

Engines and vehicles manufactured after December 31, 2006 and domiciled in the U.S. or Canada are required to meet all EPA regulations effective as of the vehicle build date, and are equipped with an emission aftertreatment system (ATS). Vehicles domiciled outside of the U.S. and Canada may not have aftertreatment equipment, depending upon local statutory emissions guidelines. See [Table 1.1](#).

Vehicle Identification

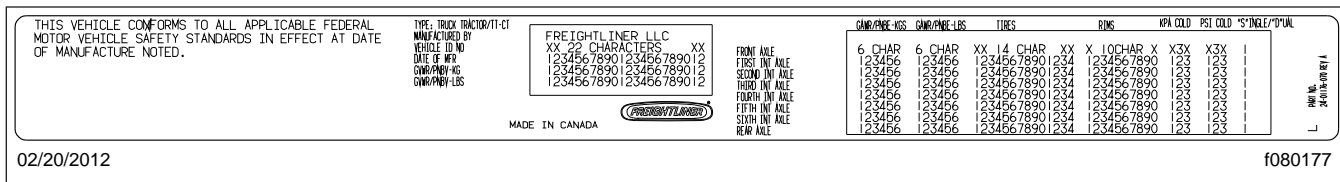

Fig. 1.2, Vehicle Certification Label

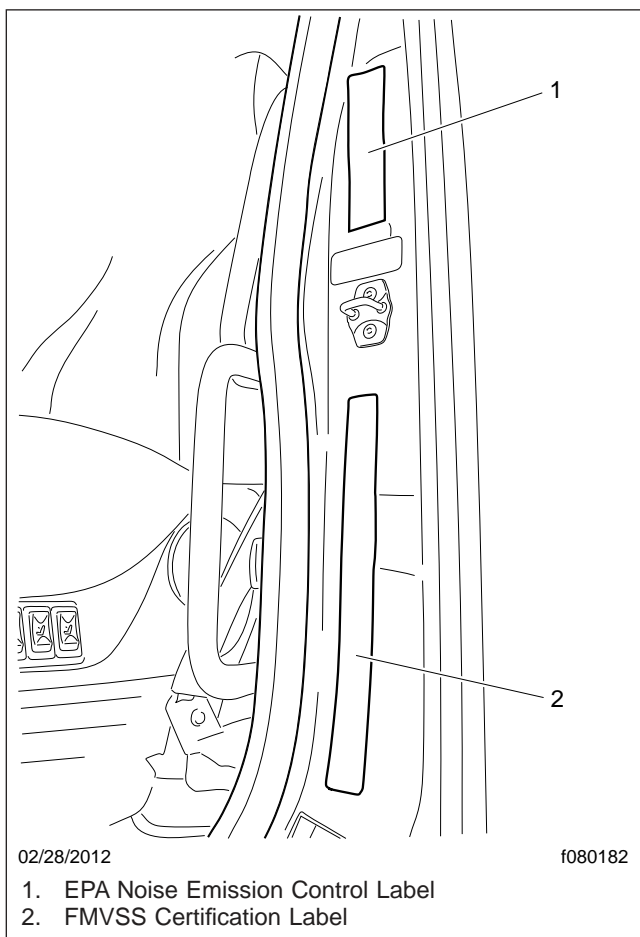

Fig. 1.3, Label Locations

A warning label on the driver-side visor contains important warning indicators in the instrument cluster that pertain to the ATS. See Fig. 1.7.

It is a violation of U.S. federal law to alter exhaust plumbing, ATS, or other components in any way that would bring the engine/vehicle out of compliance with

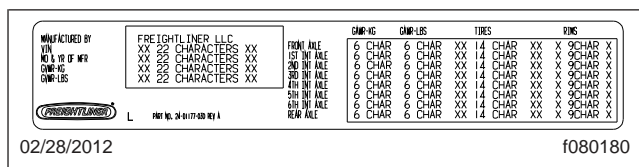

Fig. 1.4, Incomplete Vehicle Certification Label



Fig. 1.5, Canadian National Safety Mark

certification requirements [Ref: 42 U.S.C. S7522(a) (3)]. It is the owner's responsibility to maintain the vehicle so that it conforms to EPA regulations.

EPA Noise Emission Control Label

A vehicle noise emission control label (Fig. 1.8) is located on the driver-side B-pillar as shown in Fig. 1.3. It is the owner's responsibility to maintain the vehicle so that it conforms to EPA regulations.

IMPORTANT: Certain Freightliner incomplete vehicles may be produced with incomplete noise control hardware. Such vehicles will not have a vehicle noise emission control information label. For such vehicles, it is the final-stage manufacturer's responsibility to complete the vehicle in conformity to U.S. EPA regulations (40 CFR Part 205) and label it for compliance.

Vehicle Identification

Applicable Emissions System Based on Build Date and EPA Regulations	
Build Date	Regulation: Emissions Components
January 1, 2010–December 31, 2012	EPA10 (reduce NOx emissions to 0.2 g/bhp-hr): Aftertreatment device (ATD) containing a diesel particulate filter that traps soot and ash, with selective catalyst reduction (SCR) technology that utilizes diesel exhaust fluid (DEF) to convert NOx to nitrogen and water vapor.
From March 5, 2012	GHG14: Aerodynamic and fuel efficiency components including, but not limited to, tires, cab/sleeper side extenders, chassis fairings, bumper, hood, vehicle speed limiters, and idle reduction timers specifically designed to meet regulatory fuel efficiency and greenhouse gas emissions standards.



Table 1.1, Applicable Emissions System Based on Build Date and EPA Regulations

MAXIMUM GWR BY COMPONENT (KG) (LB)	FRONT AXLE 1ST INT 2ND INT 3RD INT 4TH INT 5TH INT 6TH INT REAR AXLE												COMPONENT GWR	
	AXLE	(12345) 12345	(12345) 12345	(12345) 12345	(12345) 12345	(12345) 12345	(12345) 12345	(12345) 12345	(12345) 12345	(12345) 12345	(12345) 12345	(12345) 12345		(12345) 12345
SUSPENSION	(12345) 12345	(12345) 12345	(12345) 12345	(12345) 12345	(12345) 12345	(12345) 12345	(12345) 12345	(12345) 12345	(12345) 12345	(12345) 12345	(12345) 12345	(12345) 12345	ENG/TRANS	(12345) 12345
TIRES	(12345) 12345	(12345) 12345	(12345) 12345	(12345) 12345	(12345) 12345	(12345) 12345	(12345) 12345	(12345) 12345	(12345) 12345	(12345) 12345	(12345) 12345	(12345) 12345	5TH WHL	(12345) 12345
RIMS	(12345) 12345	(12345) 12345	(12345) 12345	(12345) 12345	(12345) 12345	(12345) 12345	(12345) 12345	(12345) 12345	(12345) 12345	(12345) 12345	(12345) 12345	(12345) 12345	PARK BRAKE	(12345) 12345
HUBS/SPOKES	(12345) 12345	(12345) 12345	(12345) 12345	(12345) 12345	(12345) 12345	(12345) 12345	(12345) 12345	(12345) 12345	(12345) 12345	(12345) 12345	(12345) 12345	(12345) 12345	AXLE	(12345) 12345
BRAKES	(12345) 12345	(12345) 12345	(12345) 12345	(12345) 12345	(12345) 12345	(12345) 12345	(12345) 12345	(12345) 12345	(12345) 12345	(12345) 12345	(12345) 12345	(12345) 12345		
STEERING	(12345) 12345	(12345) 12345	(12345) 12345	(12345) 12345	(12345) 12345	(12345) 12345	(12345) 12345	(12345) 12345	(12345) 12345	(12345) 12345	(12345) 12345	(12345) 12345	VIN	12345678901234567

02/20/2012 f080178

Fig. 1.6, Component GWR Label

IMPORTANT

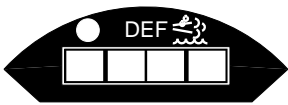
<p>DPF Regen Needed</p> 	<ul style="list-style-type: none"> • Diesel Particulate Filter (DPF) regeneration is needed. • If flashing, regenerate as soon as possible. Engine derate possible.
<p>Hot Exhaust</p> 	<ul style="list-style-type: none"> • Hot exhaust can cause fire. • Keep flammables and people away from exhaust.
<p>DEF Refill Needed</p> 	<ul style="list-style-type: none"> • Diesel Exhaust Fluid (DEF) level is low. Engine derate likely. • Refill tank with certified DEF.

See operator's manual for complete instructions. 24-01656-000

11/30/2010 f080162

Fig. 1.7, ATS Indicators

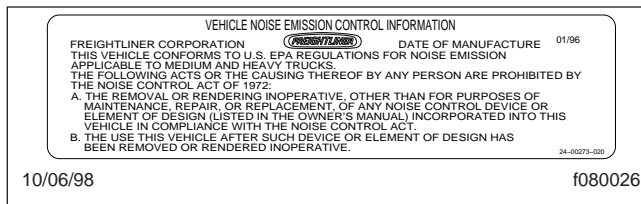

Fig. 1.8, Vehicle Noise Emission Control Label

Vehicle Emission Control Information Label

Model year 2013 and later vehicles meet additional requirements as specified by federal greenhouse gas and fuel efficiency regulations (GHG14). These vehicles are equipped with components that increase fuel efficiency and reduce GHG emissions. Components may include, but are not limited to, low-rolling resistance tires; aerodynamic devices such as hood, cab side extenders, and fuel tank fairings; vehicle speed limiters; and idle shutdown timers.

A Vehicle Emission Control Information Label is located on the driver-side door. See Fig. 1.9. It is the owner's responsibility to maintain the vehicle so that it conforms to EPA and NHTSA regulations.

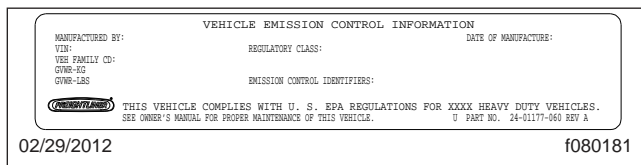

Fig. 1.9, Vehicle Emission Control Information Label

Certified Clean Idle Label

The California Air Resources Board (CARB) requires model year 2008 and newer heavy-duty diesel engines to be equipped with a non-programmable engine shutdown system that automatically shuts down the engine after five minutes of idling in order to limit emissions of particulate matter and NOx.

Certified vehicles are equipped with a label placed near the bottom edge of the driver-side door. See Fig. 1.10.



Fig. 1.10, CARB Clean Idle Label

2

Vehicle Access

Door Locks and Handles	2.1
Cab Entry and Exit	2.2
Back-of-Cab Access	2.4
Hood Opening and Closing	2.5

Vehicle Access

Door Locks and Handles

One key operates the ignition switch and all of the door locks.

IMPORTANT: Each key is numbered. Record the number so a duplicate key can be made, if needed.

To unlock the driver's door from outside the cab, insert the key in the lockset and turn it one-quarter turn clockwise (**Fig. 2.1**). To remove the key, turn it counterclockwise to its original position. Pull out on the door pull handle to open the door.

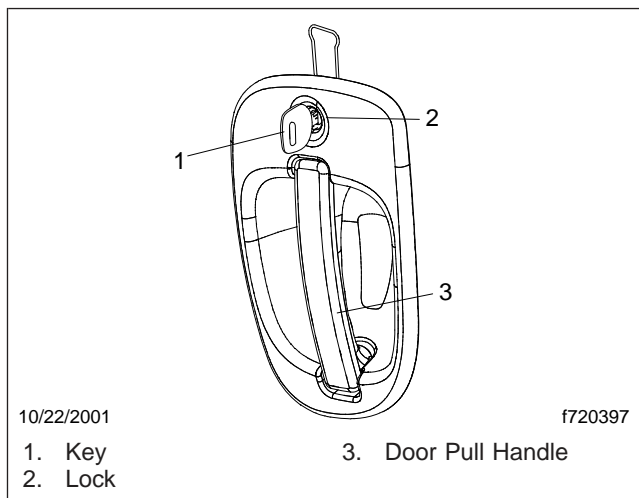

Fig. 2.1, Exterior Door Handle

To unlock the passenger's door from outside the cab, insert the key in the lockset and turn it one-quarter turn counterclockwise. Turn the key clockwise to the original position to remove it.

To open the door from the inside, lift up on the door lever. This will unlatch the door whether or not it is locked. See **Fig. 2.2**.

NOTE: The cab door locks can be operated when the doors are open.

To lock a door from outside the cab, insert the key in the lockset and turn it in the direction opposite to the unlocking direction (counterclockwise for the driver's door, clockwise for the passenger's door). Close the door if it is open.

To lock either door from inside the cab, push the lock button downwards (**Fig. 2.3**). To unlock the door without unlatching it, push the lock button upwards. A

red dot will show below the lock button when it is unlocked.

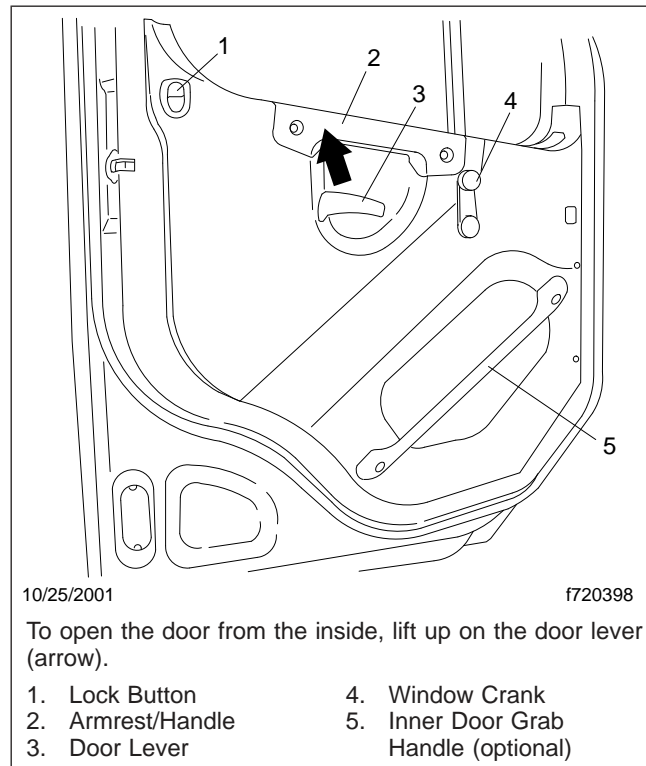

Fig. 2.2, Door Interior

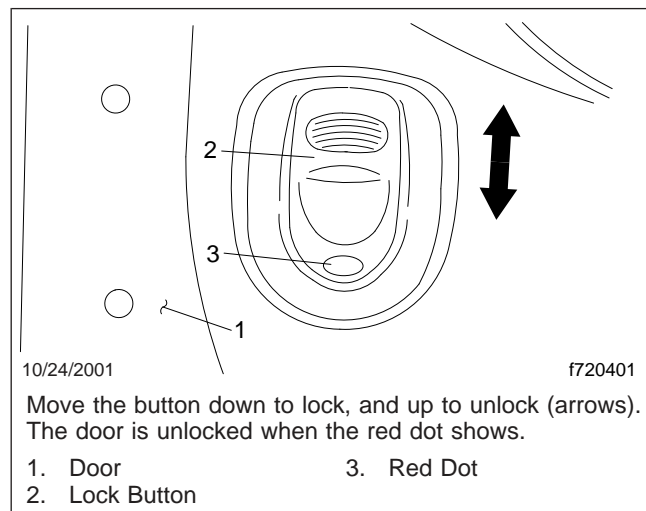

Fig. 2.3, Door Lock Button

Cab Entry and Exit

For ease of entry and exit, there are three grab handles, one on the A-pillar, one on the inner B-pillar, and an optional one on the inside of the door. In addition, the steering wheel may be used to provide secure handholds. There are at least two access steps to provide secure footholds.

NOTE: The A-pillar grab handle is not installed on the driver's side.

The grab handles, access steps, and steering wheel are all part of the cab access system. Use these "helping hands" when getting into, or out of, the cab. They will increase your security and comfort.

Entering from the Driver's Side

To enter the cab on the driver's side, use the grab handles and access steps as follows:

1. Open the driver-side door and place anything that you are carrying in the cab.
2. Grasp the B-pillar grab handle with your right hand. See [Fig. 2.4](#).
3. Grasp the door grab handle with your left hand.
4. Place your right foot on the bottom step, and pull yourself up.
5. Place your left foot on the top step.
6. Grasp the steering wheel with your left hand, and step up.
7. Step into the cab with your right foot first, and grasp the steering wheel with your right hand.

Exiting from the Driver's Side

To exit the cab from the driver's side, use the grab handles and access steps as follows:

IMPORTANT: Do not attempt to exit the cab while carrying any items in your hands.

1. If you wish to take any items with you out of the cab, place them in an accessible location on the seat or cab floor. Make sure they will not get in your way as you exit.

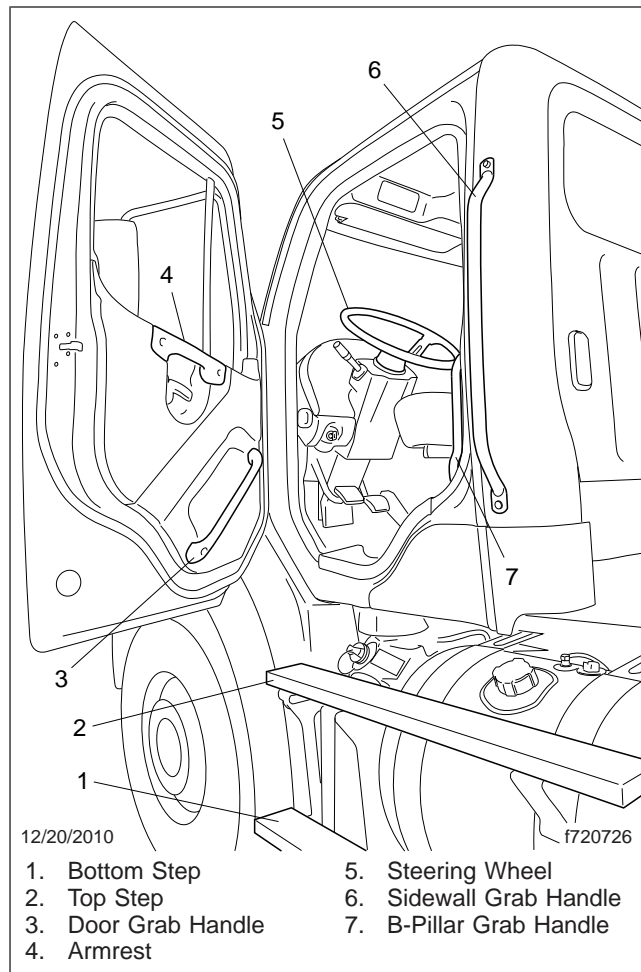

Fig. 2.4, Cab Access System, Driver's Side

WARNING

Always face in when exiting the cab. Do not attempt to exit with your back to the cab, as you would going down a flight of stairs. It is easier to slip or lose your balance. If you slip when exiting in this way, there is a greater likelihood of personal injury.

2. Grasp the steering wheel with both hands, place your left foot on the top step, then stand on the threshold facing into the cab. See [Fig. 2.4](#).
3. Using your right hand, grasp the B-pillar grab handle.
4. Move your right foot to the bottom step.

Vehicle Access

5. Move your left hand to the door grab handle.
6. Step to the ground with your left foot first.
7. Retrieve from the cab any items that you wish to take with you.

Entering from the Passenger's Side

To enter the cab on the passenger side, use the grab handles and access steps as follows:

1. Open the passenger-side door and place anything that you are carrying in the cab.
2. Using your left hand, grasp the B-pillar grab handle. See [Fig. 2.5](#).

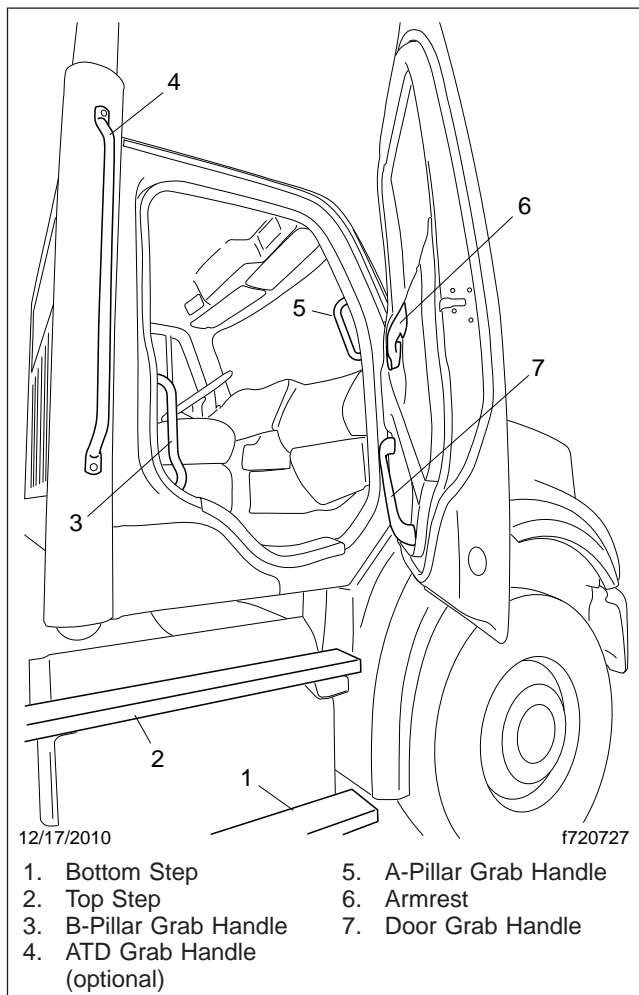

Fig. 2.5, Cab Access System, Passenger's Side and Back of Cab

3. Using your right hand, grasp the door grab handle.
4. Place your left foot on the bottom step.
5. Place your right foot on the top step.
6. Move your right hand to the A-pillar grab handle.
7. Place your left foot on the top step, then move your left hand to the A-pillar grab handle.
8. Step into the cab with your left foot first.

Exiting from the Passenger's Side

To exit the cab from the passenger side, use the grab handles and access steps as follows:

IMPORTANT: Do not attempt to exit the cab while carrying any items in your hands.

1. If you wish to take any items with you out of the cab, place them in an accessible location on the seat or cab floor. Make sure they will not get in your way as you exit.

WARNING

Always face in when exiting the cab. Do not attempt to exit with your back to the cab, as you would going down a flight of stairs. It is easier to slip or lose your balance. If you slip when exiting in this way, there is a greater likelihood of personal injury.

2. Grasp the A-pillar grab handle with both hands, then place your right foot on the top step while standing up from the seat facing inward. See [Fig. 2.5](#).
3. Place your left foot on the top step.
4. Move your left hand to the B-pillar grab handle.
5. Move your left foot to the bottom step.
6. Move your right hand to the door grab handle.
7. Step to the ground with your right foot first.
8. Retrieve from the cab any items that you wish to take with you.

Back-of-Cab Access

WARNING

External surfaces of the exhaust system remain hot after the engine has been shut down. When accessing the back of the cab or sleeper, do not touch any part of the exhaust system, or severe burns could occur.

When trailer air and electrical connections cannot be reached conveniently from the ground, Federal Motor Carrier Safety Regulations require commercial carriers to provide back-of-cab access.

Optional grab handles are mounted on each cab sidewall, or on the left sidewall only. See [Fig. 2.6](#). Steps are mounted either on the fuel tank(s) or on metal brackets. When a deck plate is necessary, it is mounted across the top of the frame rails.

IMPORTANT: Climb onto, and down from, back-of-cab access facing in toward the vehicle, as you would on a ladder. Do not climb up or down facing out away from the vehicle.

WARNING

Wet or dirty shoe soles greatly increase the chance of slipping or falling. If your soles are wet or dirty, be especially careful when climbing onto, or leaving, the back-of-cab area.

Always maintain three-point contact with the back-of-cab access supports while entering and exiting the back-of-cab area. Three-point contact means both feet and one hand, or both hands and one foot, on the grab handles, steps, and deck plates. Other areas are not meant to support back-of-cab access, and grabbing or stepping in the wrong place could lead to a fall, and personal injury.

Be careful not to get hands or feet tangled in hoses or other back-of-cab equipment. Carelessness could cause a person to trip and fall, with possible injury.

Climbing Up to Back-of-Cab

When climbing onto the deck plate, do the following:

1. Grasp the sidewall grab handle with both hands. Reach up as far as is comfortable.

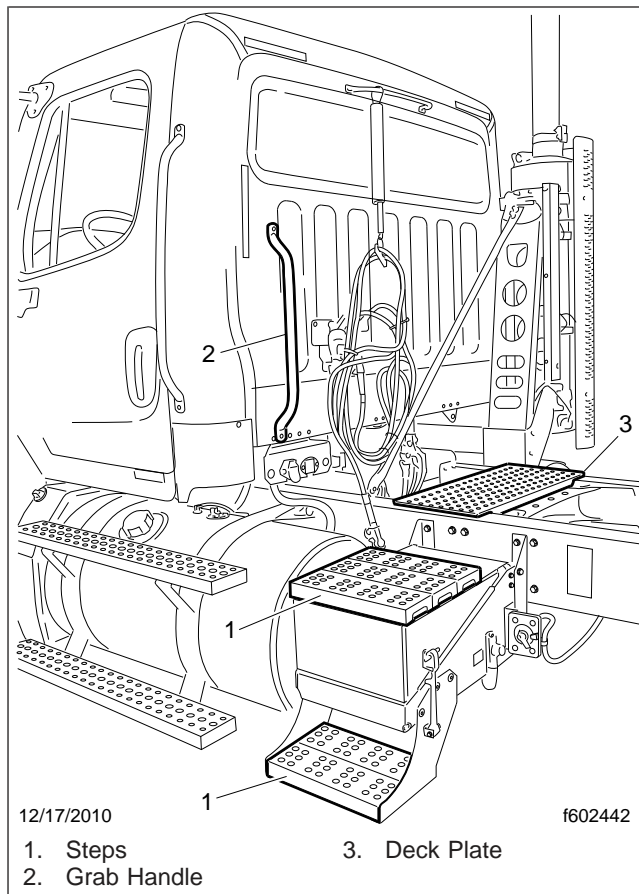

Fig. 2.6, Back-of-Cab Access Supports (typical)

2. Place one foot on the bottom step and pull yourself up.
3. Place your other foot on the top step.
4. Move your lower hand to a higher position on the grab handle.
5. Step onto the deck plate.

Climbing Down from Back-of-Cab

To climb down from the back-of-cab area:

1. Grasp the sidewall grab handle with both hands.
2. Step one foot at a time onto the top step.
3. Move your upper hand to a lower position on the grab handle.
4. Move one foot to the bottom step.

Vehicle Access

5. Move your upper hand to a lower position on the grab handle.
6. Step to the ground with your upper foot first.

Hood Opening and Closing

The hood can be raised to a full-open position. A strut helps you to raise the hood, and to lower it to the operating position. Hood restraint cables prevent the hood from overtravel. The hood strut limits the closing speed. In the operating position, the hood is secured to the cab-mounted cowl by a hold-down latch on each side of the hood.

To Tilt the Hood

1. Apply the parking brakes.
2. Release both hood hold-down latches by pulling the ends outward. See [Fig. 2.7](#).

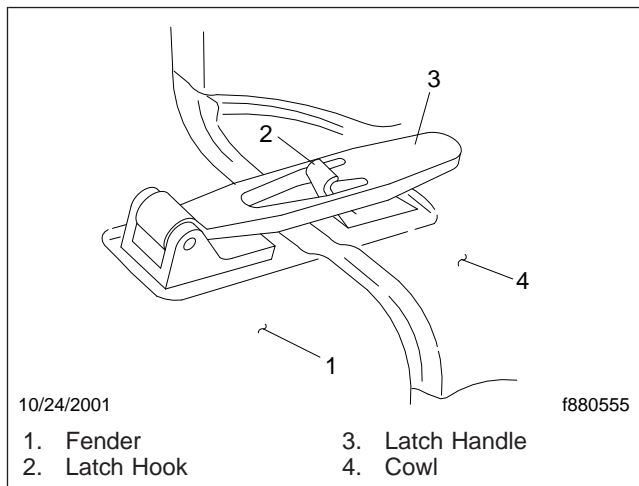

Fig. 2.7, Hood Hold-Down Latch

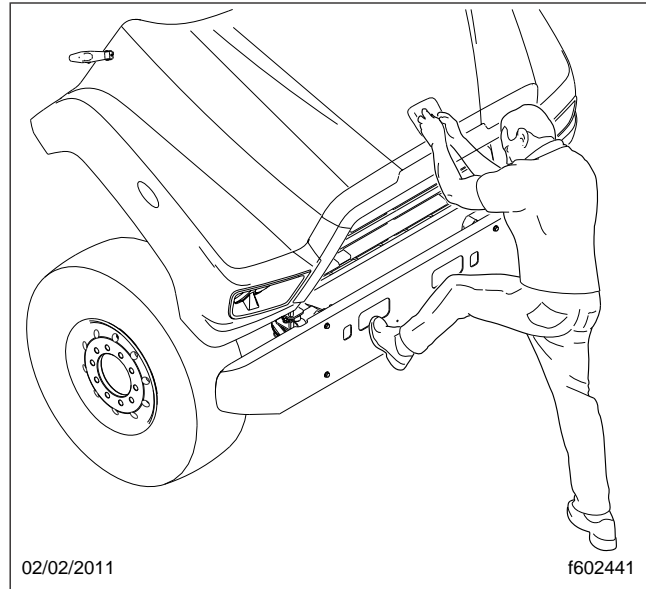

Fig. 2.8, Hood Tilting

To Return the Hood

1. Push the hood over center.
2. As the hood goes over center, the strut automatically slows its rate of descent. If needed, you can also slow its descent with your hand.
3. Make sure the hood is flush with the cowl, then secure the hood by engaging both hood hold-down latches.

IMPORTANT: Make sure that both hold-down latches are fully engaged before operating the vehicle.

NOTICE

Do not let the hood free-fall to the full-open position. To do so could cause damage to the hood or hood straps.

3. Standing in front of the hood, raise the rear of the hood upward until it reaches the over-center position (45 degrees from vertical). See [Fig. 2.8](#). Then slowly bring it to a stop.

3

Electrical System

Vehicle Power Distribution	3.1
Load Disconnect Switch	3.1
Battery Access	3.2

Electrical System

Vehicle Power Distribution

WARNING

Do not attempt to modify, add, splice, or remove electrical wiring on this vehicle. Doing so could damage the electrical system and result in a fire that could cause serious personal injury or property damage.

Power Distribution Modules

The main power distribution module (PDM) is located under the hood on the driver-side splash shield. See [Fig. 3.1](#). The PDM contains the circuit breakers and fuses required to protect the vehicle cab circuits. The label on the inside of the PDM cover identifies typical set of fuses.

The powertrain PDM (PTPDM) is mounted in the engine compartment near the main PDM. See [Fig. 3.1](#). It controls power to the engine, aftertreatment system (ATS), transmission, and other powertrain-related circuits.

The auxiliary PDM is located on the cab back wall, behind the driver's seat. See [Fig. 3.2](#). The auxiliary PDM may contain the auxiliary powernet distribution box, the body lighting PDM, and the trailer PDM, if so equipped.

Main Powernet Distribution Box

The main powernet distribution box (PNDB) is mounted on the cab frontwall next to the bulkhead module. See [Fig. 3.1](#). It supplies power to the PTPDM and main PDM, and powers other vehicle functions, including the clock. The label on the PNDB fuse cover identifies typical circuits.

An auxiliary PNDB may also be located on the cab back wall, behind the driver's seat.

Load Disconnect Switch

WARNING

Turning the load disconnect switch to the OFF position does not disconnect the connection between the battery and the starter. To work on the vehicle safely, the negative leads must be disconnected from the battery.

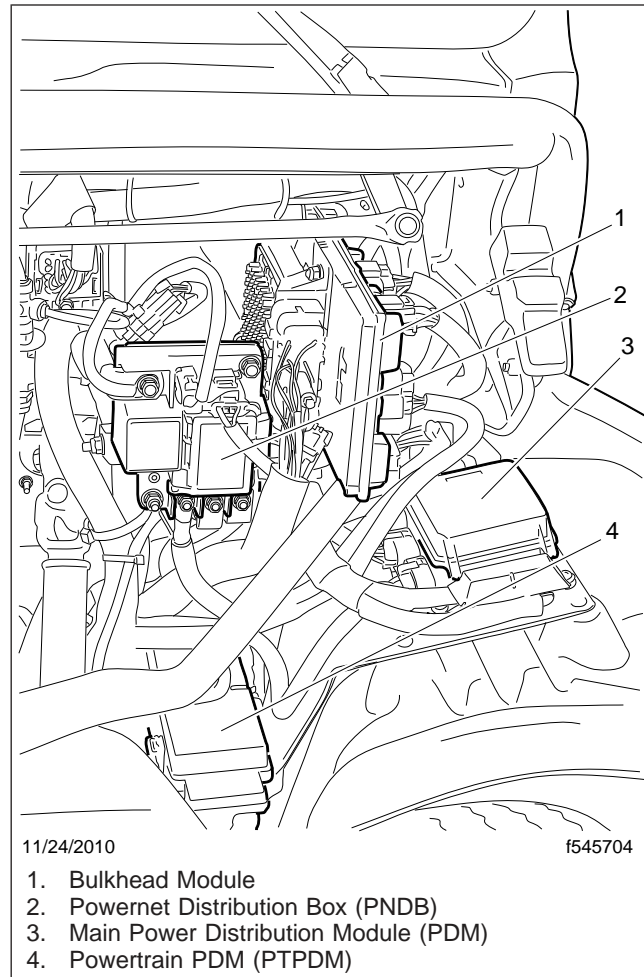

Fig. 3.1, Power Distribution Module Locations

The optional load disconnect switch ([Fig. 3.3](#)) is used to avoid excessive draw on the battery when the vehicle is parked for an extended period of time.

When the load disconnect switch is set to OFF, it signals the PNDB to disconnect battery power to powertrain and accessory loads.

The load disconnect switch is mounted in one of two locations:

- inside the cab on the left side of the driver's seat;
- on/near the battery box;

IMPORTANT: The ignition should be turned OFF before using the load disconnect switch.

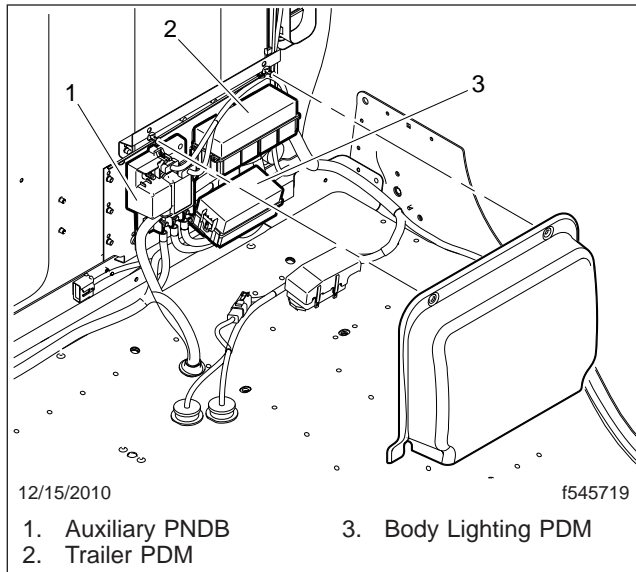

Fig. 3.2, Auxiliary Power Distribution Module

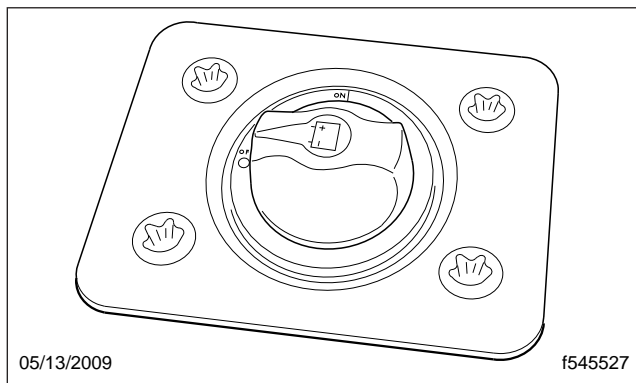

Fig. 3.3, Load Disconnect Switch

Battery Access

The batteries on a standard vehicle are located on the driver's side, behind the fuel tank. See [Fig. 3.4](#).

To access the batteries, pull the cotter pin from the latch on the battery box cover, then release the latch and lift off the cover.

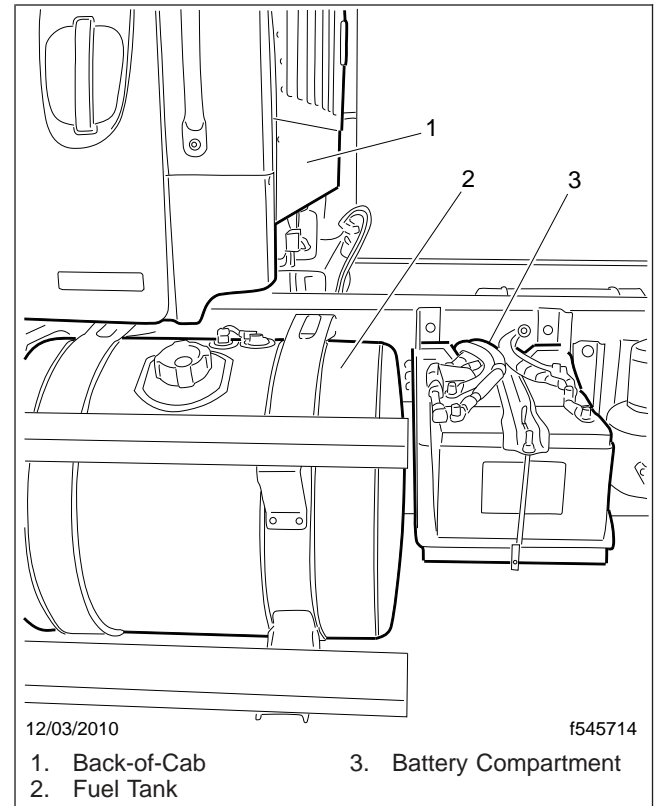

Fig. 3.4, Standard Battery Compartment Location

4

Instruments

Instrumentation Control Unit	4.1
Warning and Indicator Lights	4.2
Driver Message Center	4.7
Instruments	4.8
Overhead Instrument Panel	4.13

Instruments

Instrumentation Control Unit

The instrumentation control unit (ICU) provides the driver with engine and vehicle information. It is comprised of standard and optional gauges, an audible warning, a driver message center, and a lightbar containing warning and indicator lamps (also known as telltales). Warning and indicator lamps illuminate in red (danger), amber (caution), green (status advisory), or blue (high-beam headlights active).

Figure 4.1 shows a typical ICU3 instrument cluster.

The following headings in this chapter provide additional information and operating instructions for ICU components:

- "Warning and Indicator Lights"

- "Instruments"
- "Driver Message Center"

Ignition Sequence

When the ignition is turned on, the ICU runs a self-check. See Fig. 4.2. Observing the ignition sequence is a good way to ensure the ICU is functioning properly.

IMPORTANT: Do not crank the engine until the ICU self-check is complete.

When the ignition is turned on, the following actions should occur:

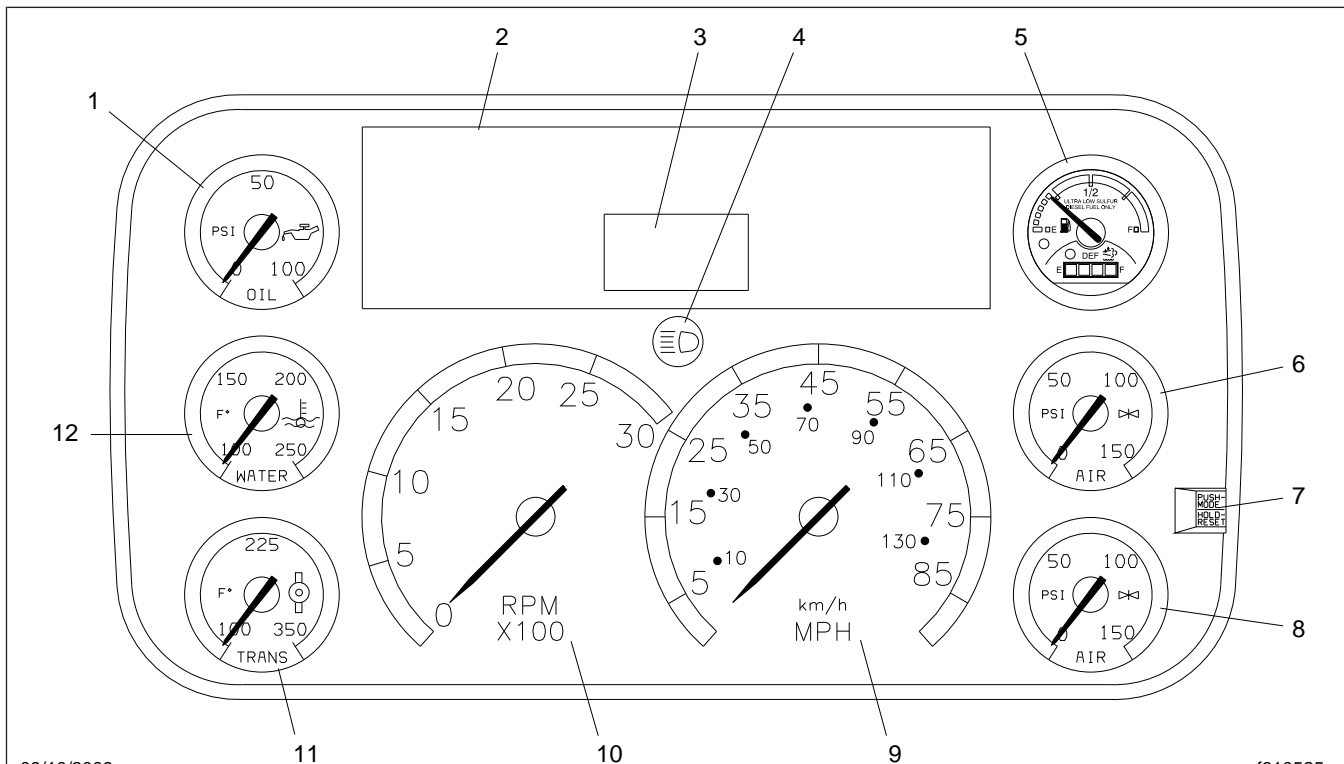

09/10/2009

f610525a

NOTE: This instrument cluster is shown with the U.S. speedometer, which shows miles per hour (mph) more prominently than kilometers per hour (km/h).

- | | | |
|----------------------------------|---------------------------------|------------------------------------|
| 1. Engine Oil Pressure Gauge | 5. Fuel/DEF Level Gauge | 9. Speedometer (U.S. version) |
| 2. Lightbar | 6. Primary Air Pressure Gauge | 10. Tachometer |
| 3. Driver Message Center | 7. Mode/Reset Button | 11. Transmission Temperature Gauge |
| 4. Headlight High-Beam Indicator | 8. Secondary Air Pressure Gauge | 12. Coolant Temperature Gauge |

Fig. 4.1, Typical ICU3 (U.S. shown)

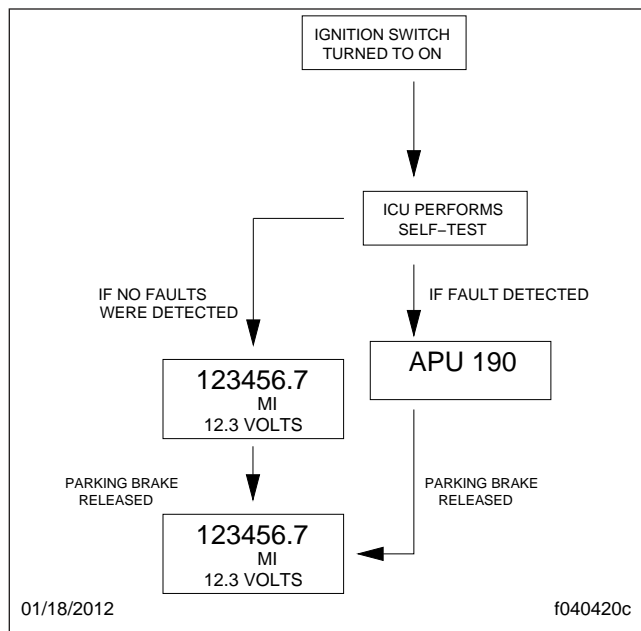

Fig. 4.2, Ignition Sequence

- electronic gauges complete a full sweep of their dials
- some warning and indicator lamps illuminate, then are extinguished
- audible alert sounds until sufficient air pressure builds up in the primary and secondary air systems
- DEF level indicator illuminates all segments green, then turns them off one at a time before turning the leftmost segment amber, then red
- software revision level of the ICU is displayed on the driver message center, followed by active faults

NOTE: Air gauges do not complete a sweep of their dials during the ignition sequence.

IMPORTANT: If any red or amber warning and indicator lamps, or telltales, do not illuminate during the ICU self-check, take the vehicle to an authorized Freightliner service facility as soon as possible. If any of the red or amber telltales or do not go out after the self-check completes,

use [Table 4.1](#) to determine if the lamp illuminated indicates a problem requiring service.

If the ICU receives active fault codes, it displays them one after the other until the parking brake is released or the ignition is turned off. Once the parking brake is completely released, the ICU displays the odometer. If there are no active faults, the ICU displays the odometer after the self-check completes.

NOTE: If active faults are present, take the vehicle to an authorized Freightliner service facility as soon as possible.

Audible Alerts

An audible alert sounds during the ignition sequence and whenever one of the following conditions exists:

- Engine oil pressure falls below the minimum preset value.
- Coolant temperature rises above the maximum preset value.
- Air pressure falls below about 70 psi (483 kPa).
- Parking brake is set with the vehicle moving faster than two miles per hour.
- System voltage falls below 12 volts.
- Door is open with the headlights on and the parking brake off.
- Driver seat belt is not fastened with the parking brake off (optional).
- Outside temperature falls below 35°F (1.7°C) (optional).











Warning and Indicator Lights











There can be up to 28 telltales installed in the ICU. If an optional lamp is not requested, the position is blank.

See [Table 4.1](#) for a list of standard and commonly used warning and indicator lamps.









Warning and indicator lamps illuminate in red (danger), amber (caution), green (status advisory), or blue (high-beam headlights active).

Instruments

Common Warning and Indicator Lamps			
Lamp Description		Color	
	STOP Engine*	Red	
	Indicates a serious fault that requires engine shutdown immediately. The engine protection system will reduce the maximum engine torque and speed, and, if the condition does not improve, will shut down the engine within 30 to 60 seconds. Safely bring the vehicle to a stop on the side of the road and shut down the engine as soon as the red light is seen. If the engine shuts down while the vehicle is in a hazardous location, turn the key to the OFF position for a few seconds, then restart the engine and move the vehicle to a safer location.		
	High Coolant Temperature		Indicates the coolant temperature is above the maximum allowable temperature.
	Low Air Pressure		Indicates air pressure in the primary or secondary reservoir has dropped below approximately 70 psi (483 kPa).
	Low Engine Oil Pressure		Indicates the engine oil pressure is below the minimum allowable pressure.
	Transmission Overheat		Indicates high transmission temperature.
	Parking Brake		Indicates the parking brake is engaged.
	Low Battery Voltage		Indicates that battery voltage is 11.9 volts or less.
	Unfastened Seat Belt	Activates with an audible alert when the system detects that the parking brake is off and the driver seat belt is not fastened on some vehicles. On other vehicles, this lamp illuminates for 15 seconds when the ignition is first turned on.	
	CHECK Engine*	Amber	
	Indicates an engine condition (low oil pressure, low coolant level, high coolant temperature, high DPF soot level, or uncontrolled DPF regeneration) that requires correction. Correct the condition as soon as possible. If the condition worsens, the STOP engine lamp will illuminate.		
	High Exhaust System Temperature (HEST)*	Slow (10-second) flashing indicates a regeneration (regen) is in progress. IMPORTANT: When the HEST lamp is illuminated, do not park the vehicle near flammable material. Solid illumination indicates high exhaust temperatures at the outlet of the tail pipe when speed is below 5 mph (8 km/h).	

Common Warning and Indicator Lamps			
Lamp Description			Color
	Diesel Particulate Filter (DPF) Status	<p>Solid illumination indicates a regen is required. Change to a more challenging duty cycle (such as highway driving) to raise exhaust temperatures for at least twenty minutes, or perform a parked regen.</p> <p>Blinking indicates that a parked regen is required immediately. An engine derate and shutdown will occur.</p>	Amber
	Malfunction Indicator Lamp (MIL)	Indicates an emissions-related fault. See the engine operation manual for details.	
	Vehicle ABS	<p>Momentary illumination indicates the vehicle ABS is engaged.</p> <p>Solid illumination indicates a problem with the vehicle ABS. Repair the ABS immediately to ensure full braking capability.</p>	
	Trailer ABS	<p>Momentary illumination indicates the trailer ABS is engaged.</p> <p>Solid illumination indicates a problem with the trailer ABS. Repair the ABS immediately to ensure full braking capability.</p>	
	No Charge	Indicates the alternator is not properly powering the electrical system.	
	Water in Fuel	Indicates the fuel may contain water. Drain any water collected in the fuel/water separators.	
	Fuel Filter Restriction	Indicates the fuel filter is clogged and requires service.	
	Optimized Idle	Indicates optimized idle is enabled.	
	Check Transmission	Indicates an undesirable transmission condition.	
	Wait To Start (EPA10)	<p>Indicates that the system is preventing the starter from cranking. This can occur when the ignition switch is turned to START before the gauge sweep has completed, or if the starter has overheated.</p> <p>Turn the ignition switch back to ON, wait for the lamp to go out, then turn the ignition switch to START again.</p>	

Instruments

Common Warning and Indicator Lamps		
Lamp Description		Color
	Start Blocked (GHG14)	Amber
<p>Indicates that the system is preventing the starter from cranking. This can occur when the ignition switch is turned to START before the gauge sweep has completed, or if the starter has overheated.</p> <p>NOTE: Illumination of the Start Blocked lamp does not indicate a problem with the starter.</p> <p>Turn the ignition switch back to ON, wait for the lamp to go out, then turn the ignition switch to START again.</p>		
	Wheel Spin	
<p>Flashing indicates the ATC system is active, or the ATC button has been pressed to allow wheel slip.</p> <p>Solid illumination indicates a problem with the ATC system. Repair the ATC system immediately to ensure full braking capability.</p>		
	Roll Stability	
	Hill Start Aid (HSA) Override	Green
<p>Indicates the HSA switch has been pressed to override the hill start assist feature.</p>		
	Engine Brake	
<p>Indicates the engine brake is enabled.</p>		
	Left-Turn Signal	
<p>Flashing indicates the outside left-turn signal lights are activated.</p>		
	Right-Turn Signal	
<p>Flashing indicates the outside right-turn signal lights are activated.</p>		
	Cruise Control	Blue
<p>Indicates the cruise control is enabled.</p> <p>NOTE: The ICU4Me does not have a green cruise control telltale.</p>		
	High-Beam Headlights	
<p>Indicates the high-beam headlights are on.</p>		

* See Fig. 4.3 for an explanation of the aftertreatment system (ATS) warning indicators, and actions required to avoid further engine protection steps.

Table 4.1, Common Warning and Indicator Lamps

Engine Protection System









When the red STOP engine lamp illuminates, most engines are programmed to shut down automatically within 30 seconds. The driver must immediately move the vehicle to a safe location at the side of the road to prevent causing a hazardous situation that could cause bodily injury, property damage, or severe damage to the engine.

See Fig. 4.3 for an explanation of the aftertreatment system (ATS) warning indicators, and actions required to avoid further engine protection steps.

gine shuts down while the vehicle is in a hazardous location, turn the key to the OFF position for a few seconds, then restart the engine and move the vehicle to a safer location.

On other engines, the engine protection system will shut down the engine. It will first derate the engine, then shut it down completely 30 to 60 seconds after the indicator illuminates (depending on the critical fault type) if the condition does not improve. Bring the vehicle to a stop on the side of the road before the engine shuts down.

Some vehicles may have a shutdown-override switch, which may be used to momentarily override the shutdown sequence. See Chapter 10 for detailed

EXHAUST AFTERTREATMENT SYSTEM INFORMATION					
INDICATOR LAMP(S)	 (Solid) Level 1	 (Flashing) Level 2	 (Flashing) Level 3	 Level 4	 WARNING 
Indicator Lamp Message(s)	Filter Regeneration Recommended.	Filter Regeneration Necessary	Parked Regeneration Required – Engine Derate	Service Regeneration Required. Engine Derate To Idle Only.	HEST (High Exhaust System Temperature)
Diesel Particulate Filter Condition	Filter is reaching capacity.	Filter is now reaching maximum capacity.	Filter has reached maximum capacity.	Filter has exceeded maximum capacity.	Flashing A regeneration is in progress.
Required Action	Bring vehicle to highway speeds to allow for an Automatic Regeneration or perform a Parked Regeneration.	To avoid engine derate, bring vehicle to highway speeds to allow for an Automatic Regeneration, or perform a Parked Regeneration as soon as possible.	Vehicle must be parked, and a Parked Regeneration must be performed. Engine will begin derate.	Vehicle must be parked, and a Service Regeneration must be performed. Check engine operator's manual for details. Engine will shut down.	Solid Exhaust components and exhaust gas are at high temperature. When stationary, keep away from people and flammable materials or vapors.
For a driver performed Parked Regeneration, vehicle must be equipped with a dash mounted Regeneration Switch.					

02/20/2009

f080156

Fig. 4.3, ATS Warning Lamps

The STOP engine lamp illuminates when the engine protection system is activated in one of two ways. On some engines, the engine protection system will derate the engine, allowing it to run at lower rpm and slower vehicle speed. Drive the vehicle to a safe location or to a service facility.

IMPORTANT: Safely bring the vehicle to a stop on the side of the road and shut down the engine as soon as the red light is seen. If the en-

information regarding the shutdown process.

IMPORTANT: Do not attempt to restart the engine while the vehicle is moving. Bring the vehicle to a safe stop, then restart the engine.

To restart the engine, turn the ignition to OFF, leave it there a few seconds, then turn the ignition to START. The engine will run for a short period and shut down again if the condition does not improve.

Instruments

Driver Message Center

The driver message center is controlled using the mode/reset switch, located on the right side of the ICU. See [Fig. 4.1](#). Tap the mode/reset switch to advance one screen; press and hold the switch to select a menu choice or reset the display. When the display resets, an audible chirp sounds.

Driving Screens

The following screens are available when the parking brake is off (when the vehicle is mobile) and no active fault codes are found. Use the mode/reset switch to scroll through the screens. To reset any values, press and hold the mode/reset switch. The driving screens appear in the following order:

- i. Odometer
- ii. Trip distance
- iii. Trip hours
- iv. Outside temperature

Parked Screens/Menus

The parked screens and menus are available when the parking brake is on and no active fault codes are found. See [Fig. 4.4](#). Use the mode/reset switch to scroll through the parked screens. To reset any values, press and hold the mode/reset switch. The parked screens appear in the following order:

- i. Odometer
- ii. Trip distance
- iii. Trip hours
- iv. Outside temperature
- v. Select units
- vi. Temperature alert
- vii. Diagnostics
- viii. Engine miles
- ix. Engine hours
- x. Setup

Temperature Alert

When the outside temperature drops to 35°F (1.7°C) or less, the ICU displays a caution text at one-second intervals for five seconds, and an audible

alert sounds. Tap the mode/reset switch to acknowledge the message. The audible alert will not sound again unless the temperature cycles above 37°F (4°C) and back to 35°F (1.7°C) or less. This warning only occurs while the ignition is on and the parking brake is released.

The temperature alert message allows the driver to enable or disable the ambient temperature warning.

Press and hold the mode/reset switch to toggle between on and off. Release the mode/reset switch, then tap it to select the displayed choice.

Diagnostics

When the DIAG screen is displayed, press and hold the mode/reset switch to access the various diagnostic screens.

The diagnostic screens are used by trained technicians to retrieve fault codes and other diagnostic information pertaining to the vehicle. If active fault codes display during start-up or at any other time, make a note of the fault code and take the vehicle to an authorized Freightliner service facility

If fault codes are displayed, press and hold the mode/reset switch to view the next fault code until reaching the DIAG screen.

Engine Miles/Hours

When the engine miles/hours screen is displayed, press and hold the mode/reset switch to access the engines screen submenu.

Setup

The setup menu allows the driver to manage ICU parameters. The setup screen submenu allows the driver to enable and change service intervals.

If service intervals are enabled and service distance or time has been exceeded, the text SERVICE HOUR/MI (KM) will display at start-up to indicate vehicle service is required.

For each parameter, press and hold the mode/reset switch to navigate to the parameter change screen. In each change screen, tap the mode/reset switch to toggle between options.

The last screen in the setup menu, **RESET EE**, is for resetting certain parameters to the original settings. Press and hold the mode/reset switch to reset the

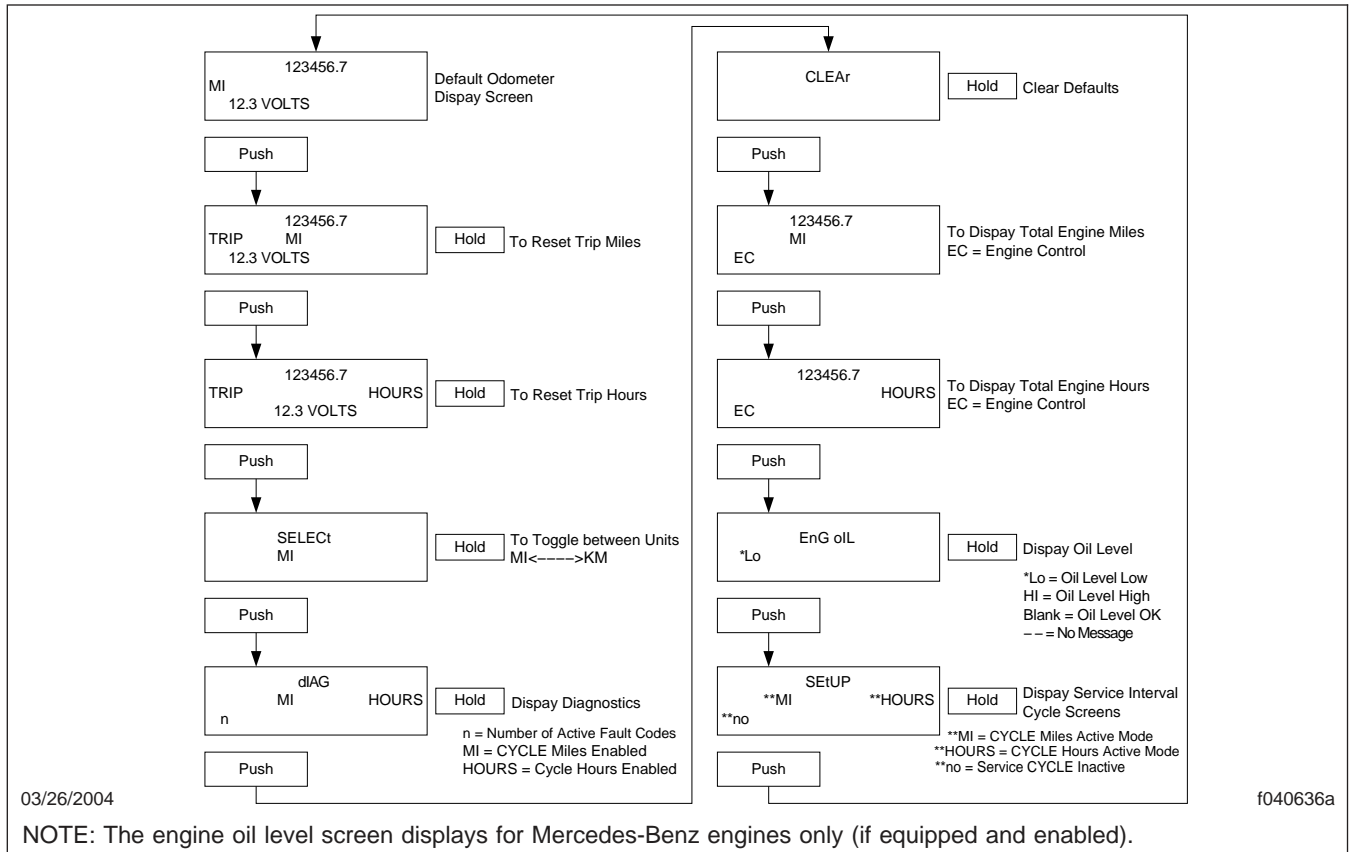

Fig. 4.4, ICU3 Stationary Screens

antilock braking system (ABS), SAMs roll call, automated transmission display, transmission heartbeat, sensor fault codes, seat belt switch learning, and engine oil level.

Instruments

Standard instruments are present on every vehicle. They are listed here in alphabetical order to make the information easier to find.

Optional instruments, typically located on the auxiliary dash panel or right-hand control panel, are not found on every vehicle. They are listed here in alphabetical order, to make the information easier to find.

Air Intake Restriction Gauge

The air intake restriction gauge indicates the vacuum on the engine side of the air cleaner. On standard installations, it is mounted on the air intake duct in

the engine compartment. As an option for easier viewing, the air intake restriction indicator (see Fig. 4.5) can be mounted on the dash, usually on the right-hand control panel.

NOTE: Rain or snow can wet the filter and cause a temporary high reading.

Air intake restriction vacuum is measured in inches of water (inH₂O). For vehicles equipped with a graduated indicator or a restriction gauge on the dash, check the gauge with the engine off. If the yellow signal stays locked in the red zone once the engine is shut down, or is at or above the values shown in Table 4.2, the air cleaner element needs to be replaced.

Vehicles may be equipped with a go/no-go restriction indicator without graduations (see Fig. 4.6) instead of a graduated indicator.

Instruments

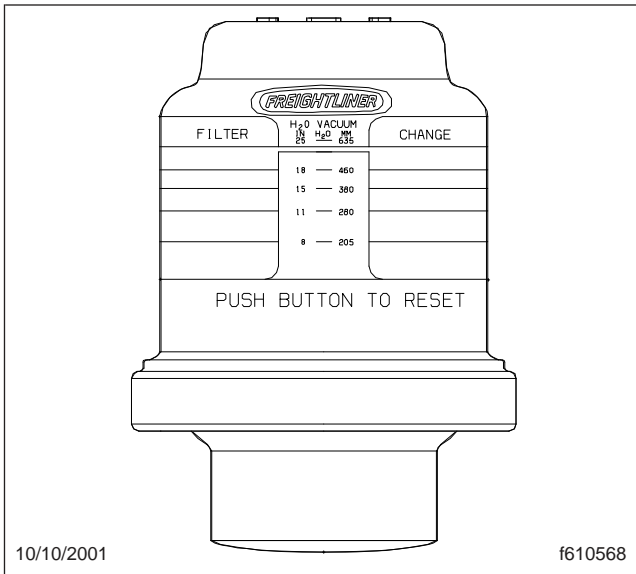

Fig. 4.5, Air Intake Restriction Indicator

Air Intake Maximum Restriction Values (inH ₂ O)		
Engine	Initial Restriction	Maximum Restriction
Cummins	10	25
Detroit™	10	22

Table 4.2, Air Cleaner Element Maximum Restriction

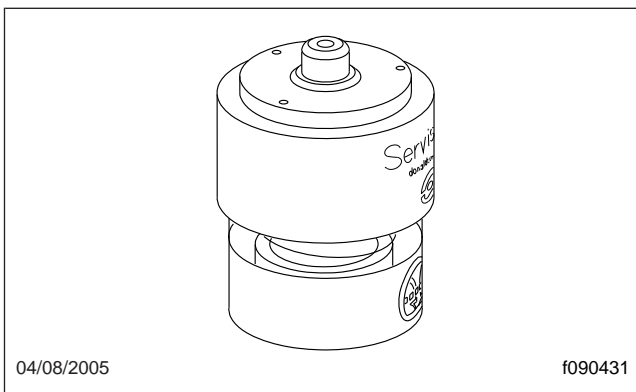

Fig. 4.6, Manual-Reset Air Restriction Indicator, Go/No-Go

Coolant Temperature Gauge

NOTICE

A sudden increase in coolant temperature may indicate engine or cooling system failure. Bring the vehicle to a safe stop and investigate the cause to prevent further damage. Do not operate the engine until the cause has been determined and corrected.

During normal engine operation, the coolant temperature gauge, as shown in Fig. 4.7, should read 175 to 195°F (79 to 91°C). If the temperature remains below 160°F (71°C), inspect the cooling system to determine the cause.

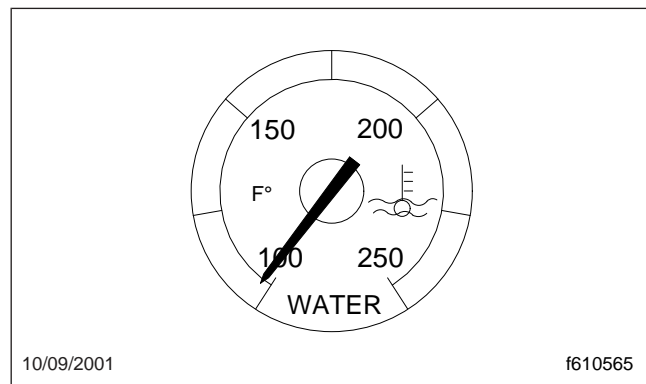

Fig. 4.7, Coolant Temperature Gauge

If coolant temperature rises above the maximum temperature listed in Table 4.3, the CHECK engine lamp will illuminate. If the condition does not improve, the STOP engine lamp will also illuminate and an audible warning will sound. The engine will then derate or shut down, depending on the type of engine protection system installed.

Maximum Coolant Temperature	
Engine Make	Temperature: °F (°C)
Caterpillar	230 (110)
Cummins	225 (107)
Detroit	215 (101)
Mercedes-Benz	222 (105)

Table 4.3, Maximum Coolant Temperature

Drive Axle Oil Temperature Gauges

NOTICE

A sudden increase in oil temperature that is not caused by a load increase may indicate mechanical failure. Bring the vehicle to a safe stop and investigate the cause to prevent further damage. Do not operate the vehicle until the cause has been determined and corrected.

During normal operation, drive axle oil temperature gauges (see Fig. 4.8) should read between 160 and 220°F (71 and 104°C).

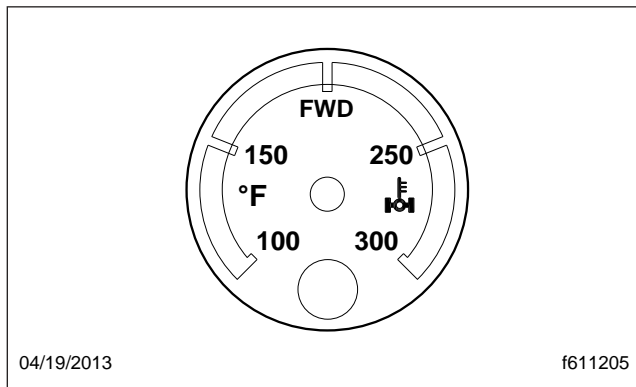

Fig. 4.8, Forward-Rear Drive Axle Oil Temperature Gauge

Under heavy loads, such as when climbing steep grades, temperatures that exceed the normal oil temperature range for a short period are not unusual. If the temperature returns to normal when the load decreases, there is no problem.

Engine Oil Pressure Gauge

NOTICE

A sudden decrease or absence of oil pressure may indicate mechanical failure. Bring the vehicle to a safe stop and investigate the cause to prevent further damage. Do not operate the engine until the cause has been determined and corrected.

The engine oil pressure gauge, as shown in Fig. 4.9, displays the current engine oil pressure. If engine oil pressure falls below the minimum levels shown in Table 4.4, the CHECK engine lamp will illuminate. If

the condition does not improve, the STOP engine lamp will also illuminate and an audible warning will sound. The engine will then derate or shut down, depending on the type of engine protection system installed.

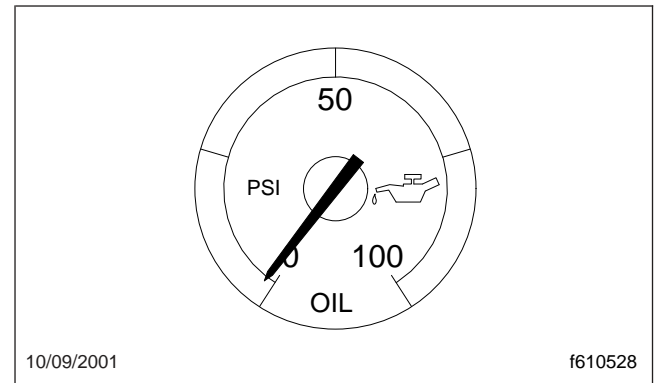

Fig. 4.9, Engine Oil Pressure Gauge

Minimum Oil Pressure *		
Engine Model	At Idle Speed: psi (kPa)	At Rated RPM: psi (kPa)
Caterpillar	10–20 (69–138)	30–45 (207–310)
Cummins	15 (103)	35 (241)
Detroit	14 (97)	55 (350)
Mercedes-Benz	7 (50)	36 (250)

* Oil pressures are given with the engine at operating temperature. With the engine cold, oil pressure may be higher. Individual engines may vary from the listed pressures; observe and record pressures when the engine is new to create a guide for checking engine condition.

Table 4.4, Minimum Oil Pressure

Engine Oil Temperature Gauge

NOTICE

A sudden increase in oil temperature that is not caused by a load increase may indicate mechanical failure. Bring the vehicle to a safe stop and investigate the cause to prevent further damage. Do not operate the engine until the cause has been determined and corrected.

During normal operation, the optional engine oil temperature gauge (Fig. 4.10) should read in the following temperature ranges:

- 160 to 195°F (71 to 91°C) for Caterpillar engines

Instruments

- 200 to 260°F (93 to 126°C) for Detroit and Cummins engines
- 177 to 203°F (81 to 95°C) for Mercedes-Benz engines

Under heavy loads, such as when climbing steep grades, temperatures that exceed the normal oil temperature range for a short period are not unusual. If the temperature returns to normal when the load decreases, there is no problem.

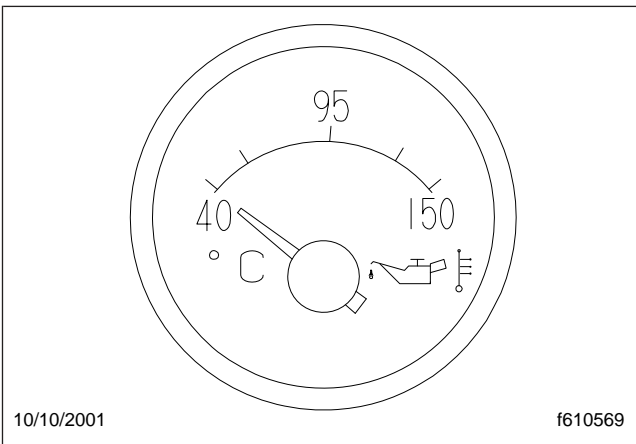

Fig. 4.10, Engine Oil Temperature Gauge

Fuel/Diesel Exhaust Fluid (DEF) Gauge

For engines that are EPA10-compliant or newer, the fuel and DEF levels are measured in a dual purpose fuel/DEF level gauge. See Fig. 4.11.

The diesel fuel level is indicated at the top of the gauge, with a low-fuel warning lamp that illuminates when the diesel fuel level registers 1/8th of capacity.

The DEF level is indicated in the lightbar on the lower portion of the gauge. There is a low DEF level warning lamp that illuminates amber when the DEF level reaches 10% of capacity. See Chapter 7 for details of the DEF gauge functions.

Primary and Secondary Air Pressure Gauges



If air pressure falls below minimum pressure, the braking ability of the vehicle will be limited. Slow

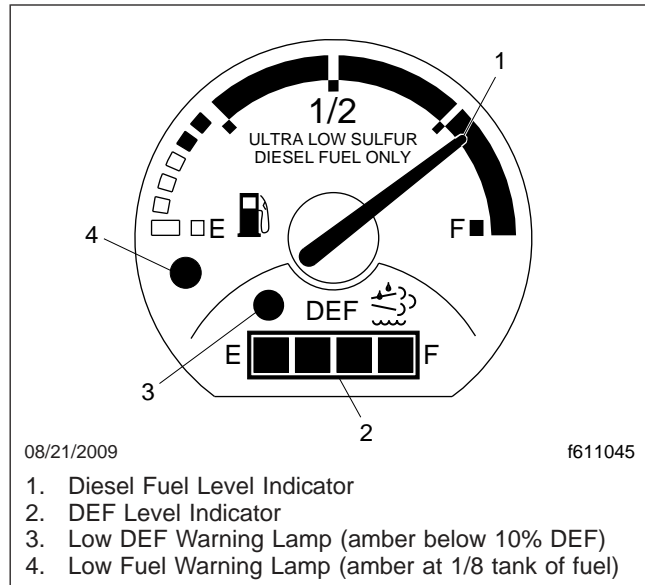

Fig. 4.11, Fuel/DEF Gauge, EPA10

the vehicle down and bring it to a gradual stop. Do not attempt to move the vehicle until air pressure has risen above the minimum level. Moving a vehicle without adequate braking power could cause an accident resulting in property damage, personal injury, or death.

Air pressure gauges, as shown in Fig. 4.12, register the pressure in the primary and secondary air systems. The gauges are labeled for the A or B reservoir. Normal pressure with the engine running is 100 to 120 psi (689 to 827 kPa) in both systems.

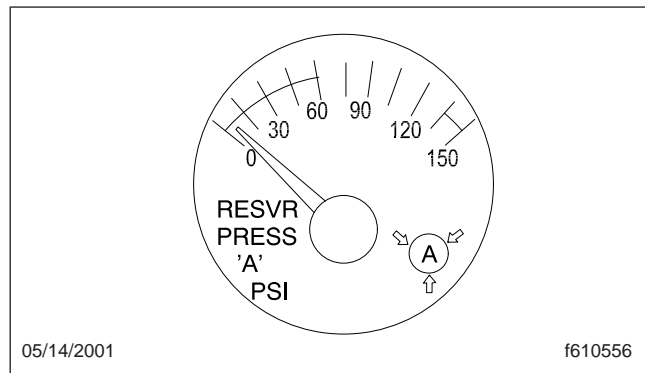

Fig. 4.12, Air Pressure Gauge (reservoir A shown)

A low-air-pressure warning light and audible alert, connected to both the primary and secondary systems, activate when air pressure in either system drops below approximately 70 psi (483 kPa).

When the engine is started, the warning light and audible warning remain on until air pressure in both systems exceeds minimum pressure.

Speedometer

Three speedometer options are available. The U.S. version of the speedometer registers speed in both miles per hour (mph) and kilometers per hour (km/h), with mph in larger numbers. The metric version of the speedometer face reverses this arrangement, with km/h in larger numbers. The metric-only version shows km/h exclusively.

Tachometer

The tachometer indicates engine speed in revolutions per minute (rpm) and serves as a guide for shifting the transmission and keeping the engine in the appropriate rpm range. For low idle and rated rpm, see the engine identification plate.

Transmission Fluid Temperature Gauge

The transmission fluid temperature gauge, shown in [Fig. 4.13](#), measures the transmission lubricant operating temperature. Temperatures vary by application, but the transmission fluid temperature gauge reading should not exceed 250°F (121°C).

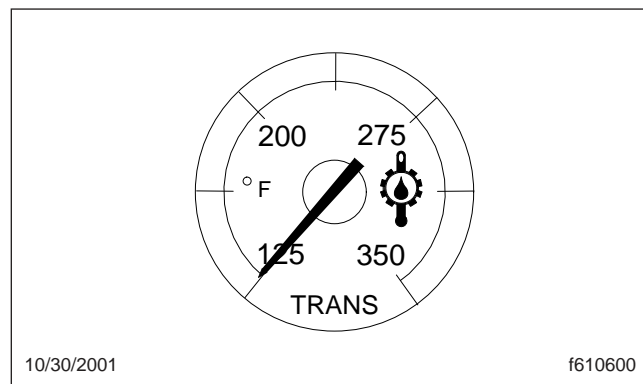

Fig. 4.13, Transmission Fluid Temperature Gauge

NOTICE

A sudden increase in transmission fluid temperature that is not caused by a load increase may indicate mechanical failure. Bring the vehicle to a safe stop and investigate the cause to prevent further damage. Do not operate the vehicle until the cause has been determined and corrected.

Under heavy loads, such as when climbing steep grades, temperatures that exceed the normal oil temperature range for a short period are not unusual. If the temperature returns to normal when the load decreases, there is no problem.

Turbocharger Boost Pressure Gauge

A turbocharger boost pressure gauge indicates the pressure in the intake manifold, in excess of atmospheric pressure, being created by the turbocharger.

Voltmeter

The voltmeter indicates the vehicle charging system voltage when the engine is running and the battery voltage when the engine is off. By monitoring the voltmeter, the driver can stay aware of potential battery charging problems and have them fixed before the batteries discharge enough to create starting difficulties. Cascadia vehicles are equipped with either a voltmeter gauge, or a digital voltmeter readout located on the bottom line of the dash message center.

The voltmeter will normally show approximately 13.7 to 14.1 volts when the engine is running. The voltage of a fully charged battery is 12.7 to 12.8 volts when the engine is off. Battery voltage under 12.0 volts is considered a low battery, and a completely discharged battery will produce only about 11.0 volts.

If the voltmeter shows an undercharged or overcharged condition for an extended period, have the charging system and batteries checked at an authorized Freightliner service facility.

On a vehicle equipped with a battery isolator system, the voltmeter measures the average voltage of all the batteries when the engine is running. When the engine is off, the voltmeter shows only the isolated battery voltage and does not indicate the voltage of the engine-starting batteries.

Instruments

Overhead Instrument Panel

The optional overhead instrument panel ([Fig. 4.14](#)) may hold a citizen's band (C/B) radio, a microphone clip, and any switches that can not be accommodated on the driver's or auxiliary dash panels.

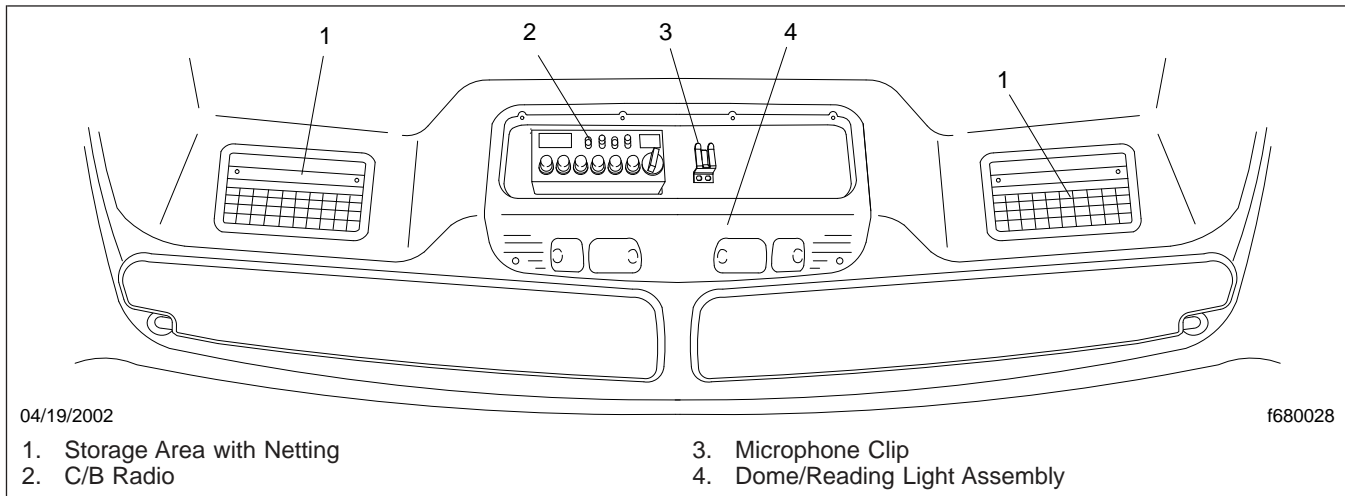

Fig. 4.14, Overhead Instrument Panel

The underside of the overhead console also holds the sun visors and the optional dome/reading light assembly. For more information on the dome/reading light assembly, see [Chapter 8](#).

5

Driver Controls

Ignition Switch	5.1
Control Panels	5.1
Lighting Controls	5.3
Multifunction Turn Signal Lever Controls	5.5
Horn Controls	5.6
Powertrain Controls	5.7
All Wheel Drive Controls	5.11
Brake Controls	5.12
Adjustable Steering Column Controls	5.13
Suspension Controls	5.13
Climate Controls	5.14
Seat Controls	5.14

Driver Controls

Ignition Switch

NOTE: Freightliner vehicles are offered with various chassis and body components. Because of the various options, the information contained in this chapter may not apply to every vehicle.

The ignition switch ([Fig. 5.1](#)) is located on the lower portion of the left-hand dash. The switch has four positions: OFF, ACCESSORY, ON, and START.

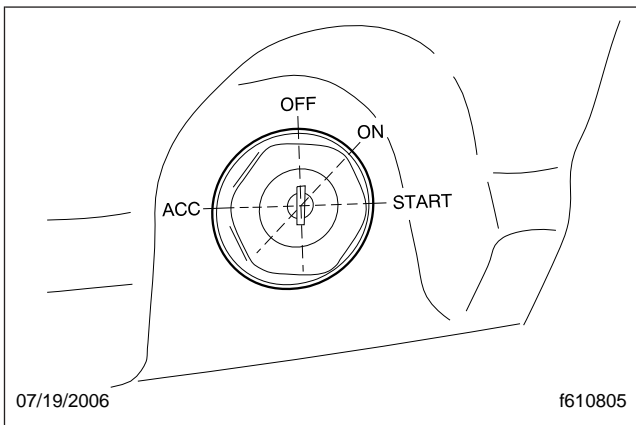

Fig. 5.1, Ignition Switch Positions

In the OFF position, the key slot is vertical. The key can be inserted and removed only in the OFF position.

The following functions are operable when the ignition switch is in the OFF position (regardless of whether the key is inserted):

- low-beam headlights
- taillights
- brake lights
- dome lights
- clearance lights
- turn signals
- hazard warning lights
- horn
- CB radio
- power windows
- cigarette lighter
- clock

Turn the key counterclockwise to reach the ACCESSORY position. In addition to all the functions that are operable with the ignition switch in the OFF position, the following functions are operable when the switch is in the ACCESSORY position:

- radio or stereo system
- mirror heat
- air dryer
- backup lights
- windshield fan(s)

Turn the key clockwise past the OFF position to reach the ON position. With the switch in the ON position, all electrical systems are operable and the instrument control unit (ICU3) runs through the ignition sequence. See [Fig. 5.2](#).

When the ignition switch is turned to the ON position, all electronic gauges complete a full sweep of their dials, the warning and indicator lamps illuminate, and the buzzer sounds for three seconds. Wait for the gauge sweep to complete before starting the engine.

Switching on the ignition and releasing the parking brakes automatically activates the daytime running lights, if equipped. The daytime running lights will operate until the parking brakes are applied or the headlights are turned on.

NOTE: Daytime running lights are standard on all vehicles domiciled in Canada.

Turn the key clockwise past the ON position to reach the START position and start the engine. Do not operate the starter longer than thirty seconds, and wait at least two minutes between starting attempts to allow the starter to cool. Release the key the moment the engine starts.

Control Panels

The left-hand control panel ([Fig. 5.3](#), Item 1) contains a face vent and four switches arranged in a vertical line. In the standard cab, the four switches usually consist of the headlight, panel light increase/decrease, and the cruise control on/off and set/resume switches.

The instrument cluster is located directly behind the steering wheel. The mode/reset button, located on the right side of the instrument cluster, allows the

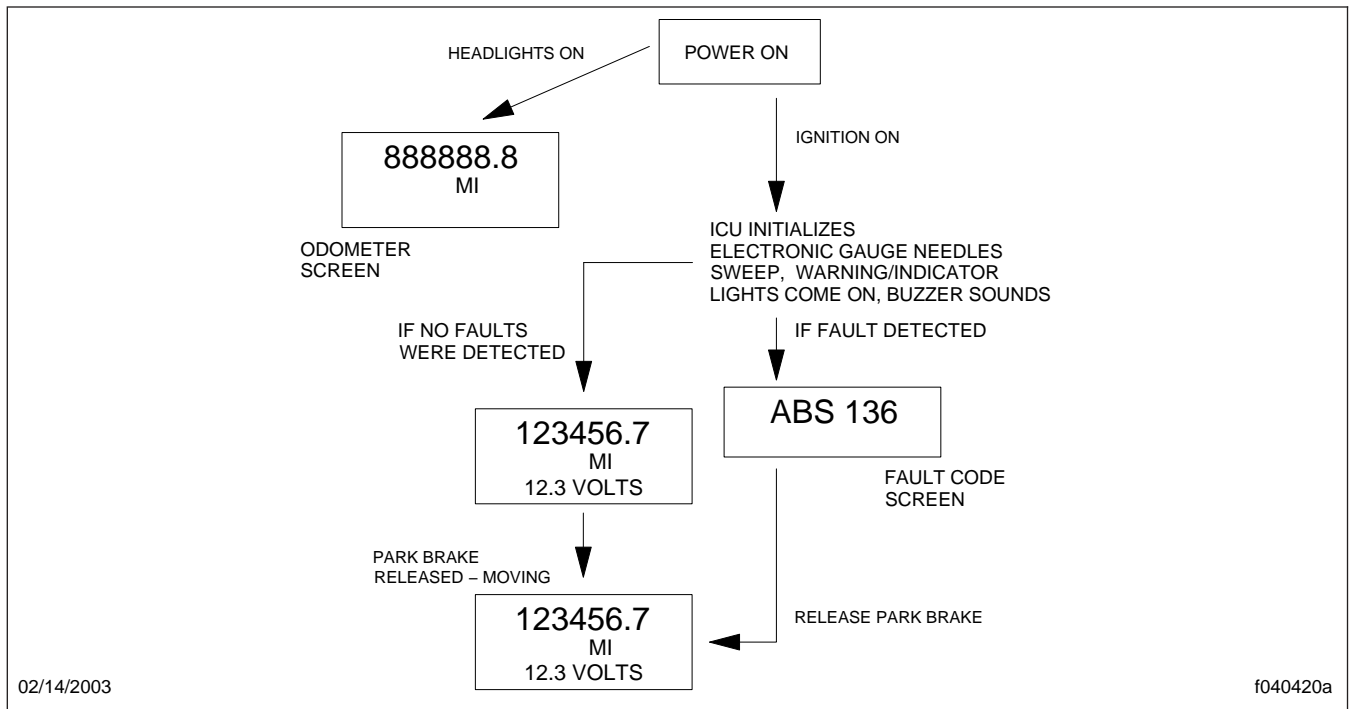

Fig. 5.2, Ignition Sequence

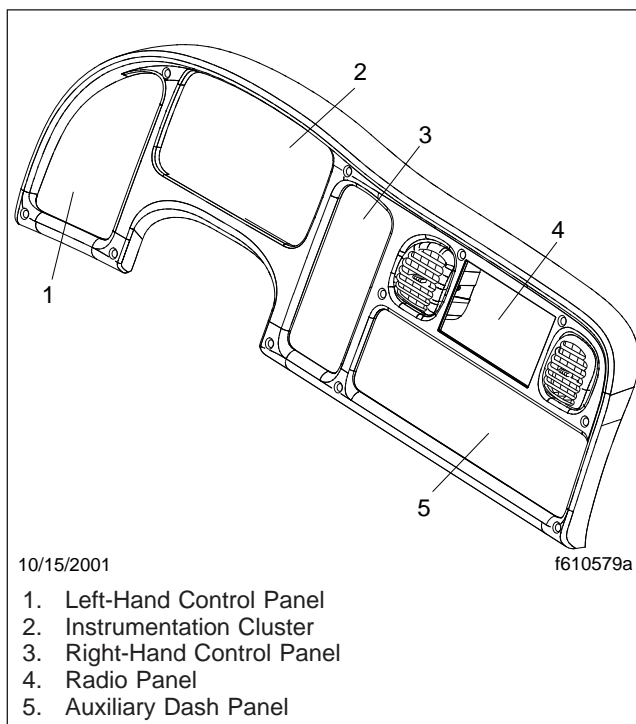

Fig. 5.3, Control Panels

driver to scroll through a number of options on the driver display screen.

The right-hand control panel (**Fig. 5.3**, Item 3) usually contains the transmission push-button shift selector (vehicles with an automatic transmission) and the trailer brake valve. On vehicles with a manual transmission, a variety of switches are installed here. If there is a dash-mounted air intake restriction indicator, it is often mounted on the right-hand panel.

The radio panel contains the radio controls and two face vents on either side of the radio.

The auxiliary dash panel (**Fig. 5.3**, Item 5), located below the radio panel, contains the parking brake control and trailer air supply valves, the cigarette lighter (push the knob in to heat the element; the knob will pop out when the element is hot), and a variety of switch options. The auxiliary panel may also contain an antenna connection and positive (+) and negative (-) power connections for a citizen's band (CB) radio.

The climate control panel is located below the auxiliary dash panel, between the cupholders.

Driver Controls

The optional overhead instrument panel (**Fig. 5.4**) holds the CB radio, a microphone clip, any switches that can not be accommodated on the lower control panels, sun visors, and an optional dome/reading light assembly.

Lighting Controls

When the panel lights are on, most switch legends are backlit with a colored light, typically green, to allow the driver to find switches more easily in the dark. When a switch is activated, the switch icon is backlit with a colored light, typically amber.

Exterior Light Controls

Exterior light controls are listed here in alphabetical order.

Hazard Warning Light Switch

The hazard warning light flasher (**Fig. 5.5**) is a red rocker switch located on the top of the steering column.

To activate the hazard warning lights, press the upper part of the rocker (pushing towards the dash). To deactivate the hazard warning lights, press the lower part of the switch (towards the steering wheel).

Headlight Switch

A three-position headlight paddle switch (**Fig. 5.6**) on the left-hand dash is used to operate the low-beam headlights.

When the switch is in the uppermost position, the headlights and all other exterior lights (excluding the optional fog, spot, and utility lights) are on. All vehicle lighting is off when the switch is in the middle position. When the switch is in the downward position, only the clearance lights, marker lights, and the tail-lights are illuminated.

When the any exterior lights are on, the instrument panel lights also illuminate.

High-Beam Headlight Control

With the low-beam headlights on, push the turn signal lever forward (toward the windshield) to turn on the high-beam headlights. Pull the turn signal lever back to the neutral position to turn the high-beams off. See **Fig. 5.7**.

With the low-beam headlights on, pull the lever towards you to flash the high-beam headlights momentarily.

When the high-beam headlights are on, a blue light illuminates on the instrument cluster between the tachometer and speedometer.

The low-beam headlights remain on continuously during high-beam headlight operation. If the low-beams are turned off, the high-beams turn off also.

Marker Light Interrupt Switch

The marker light interrupt (MRKR INT) paddle switch (**Fig. 5.8**) temporarily deactivates the marker lights and taillights, if equipped.

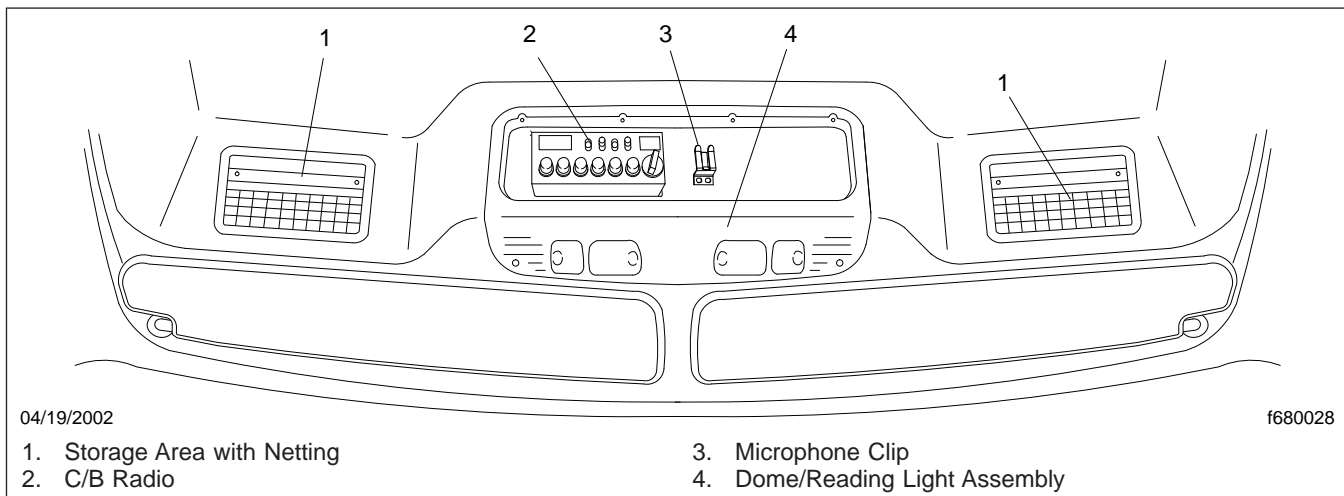

Fig. 5.4, Overhead Control Panel

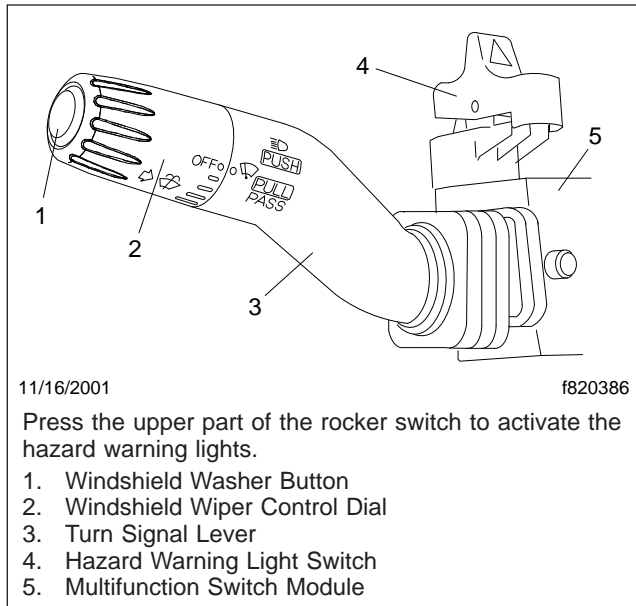

Fig. 5.5, Hazard Warning Light Switch

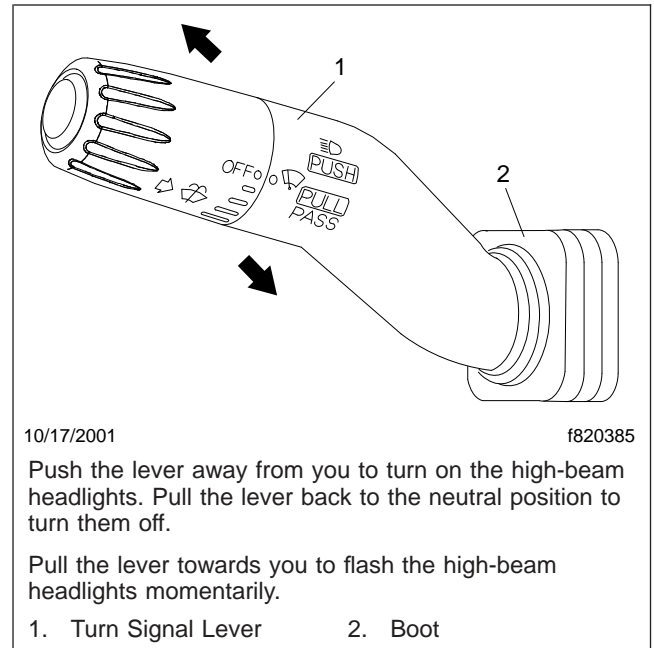

Fig. 5.7, High-Beam Headlight Operation

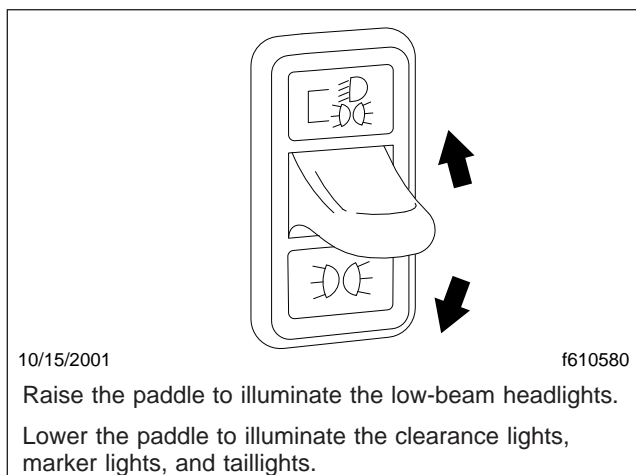

Fig. 5.6, Headlight Switch

With the vehicle lights on, raise and hold the paddle switch to briefly turn off the marker lights and taillights. The dash lights will flash with the marker lights when the switch is actuated. When the paddle is released the marker lights will return to normal operation. With the vehicle lights off, raise the paddle switch briefly to turn the marker lights on.

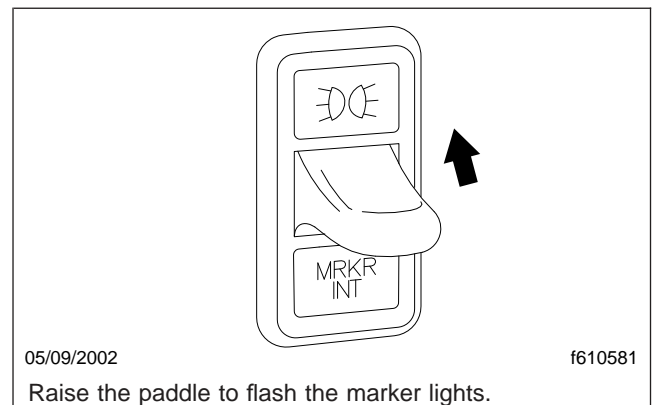

Fig. 5.8, Marker Light Interrupt Switch

Panel Light Increase/Decrease Switch

When the instrument panel lights are on, they can be brightened or dimmed by using the INCR/DECR rocker switch (**Fig. 5.9**), located just below the headlight switch.

To brighten the panel lights, press the upper part of the rocker switch. To dim the panel lights, press the lower part of the rocker switch.

Driver Controls

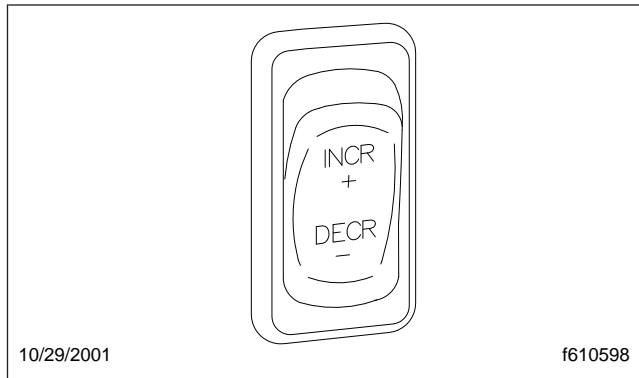

Fig. 5.9, Panel Light Increase/Decrease Switch

Spotlight Switch

The spotlight switch is located on the pivoting handle of the spotlight. There may be a single spotlight assembly mounted on the driver's door, or one on each door.

Utility Light Switch

The utility light switch, if equipped, operates one of the following lights or sets of lights:

- A single utility light swivel-mounted in the center of the cab roof;
- Two fixed utility lights mounted on each side of the cab roof;
- Two flush-mounted utility lights mounted on each side of the back of the cab.

To turn the utility light(s) on, press the upper part of the utility light (UTLY LAMP) rocker switch (Fig. 5.10). To turn the utility light(s) off, press the lower part of the rocker switch.



Fig. 5.10, Utility Light Switch

Interior Light Controls

Overhead Console Lights

In cabs with an overhead console, there is an optional overhead light assembly containing a diffuse dome light and clear reading lights. See Fig. 5.11.

Like the rear dome light, the reading lights are door-activated.

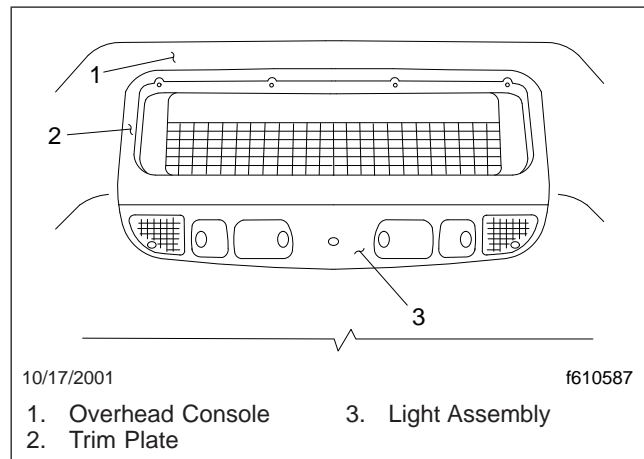

Fig. 5.11, Overhead Console Dome Lights

Rear Dome Light

The standard rear dome light is installed on the back of the cab above the rear window.

In the standard cab, there is one switch in the driver's door that controls dome light illumination when the driver's door is open. A second optional switch may be installed that controls illumination when the passenger-side door is open.

Multifunction Turn Signal Lever Controls

The turn signal lever is mounted on the steering column. The lever operates the following functions:

- Turn signals
- Windshield wipers and washers
- Headlight high-beams (see "Light Controls" section above)

Turn Signal Controls

Moving the turn signal lever down (**Fig. 5.12**) turns on the left-turn signal; moving it up turns on the right-turn signal.

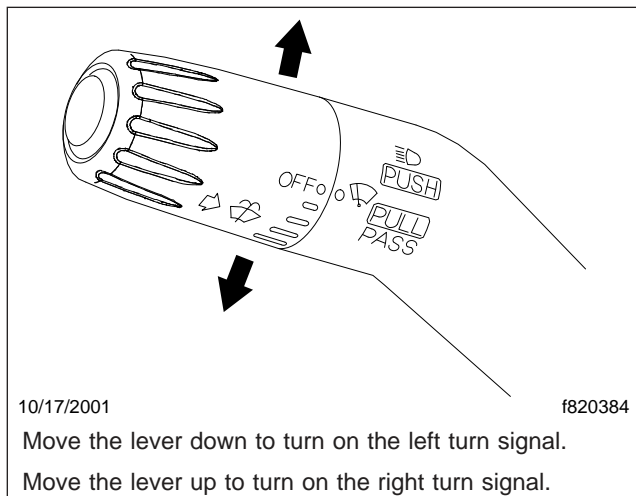

Fig. 5.12, Turn Signal Controls

When a turn signal is activated, a green indicator light flashes on the right or left side of the instrument cluster.

The turn signal lever automatically returns to the neutral position (self-cancels) when the steering wheel returns to the straight ahead position after a turn. To manually cancel the signal, move the lever to the neutral position.

Windshield Wiper/Washer Controls

NOTICE

Do not attempt to manually move the windshield wiper arms. Wiper motor damage will occur if the arms are forcibly moved.

The wipers are operated by a rotary dial located at the end of the turn signal lever. See **Fig. 5.13**. There are five delay settings (marked on the dial by lines of increasing length) and two steady speed settings, LO and HI.

Rotating the control dial away from you (counter-clockwise) turns the wipers on. If they are already on, rotating the handle further forward increases the speed of the wipers through the various delay settings, then to LO and HI.

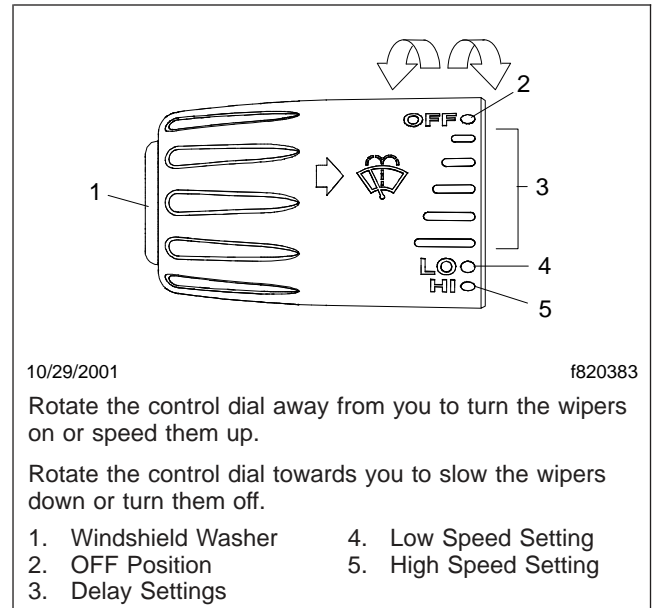

Fig. 5.13, Windshield Wiper/Washer Controls

Rotating the control dial toward you (clockwise) causes the wipers to slow down. Rotating the control dial clockwise as far as it will go turns the wipers off.

The windshield washers are operated by a yellow button at the end of the turn signal lever. To operate the washers, press and hold the button in until you want the washers to stop.

Horn Controls

NOTE: It is possible to have both types of horn installed on one vehicle.

Air Horn

The air horn is controlled by a wire lanyard hanging just inboard of the driver's door. See **Fig. 5.14**. Pull downward on the lanyard to sound the air horn.

Electric Horn

The electric horn button is located in the center of the steering wheel. To sound the horn, press down on the button. See **Fig. 5.15**. The horn will sound as long as the button is pressed, up to 60 seconds.

Driver Controls

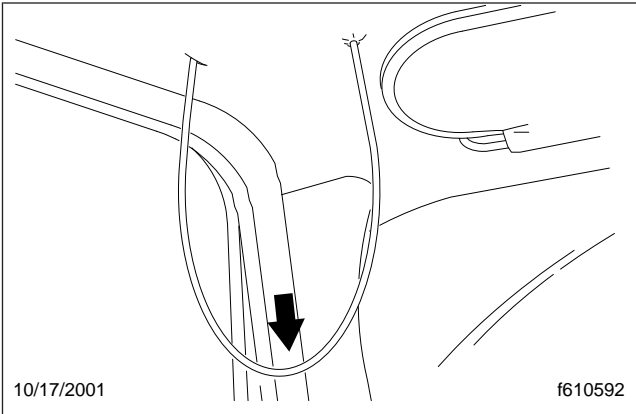
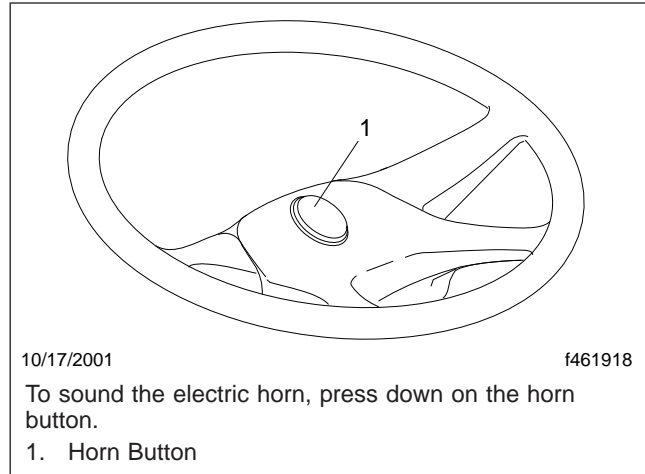

Fig. 5.14, Air Horn Control



10/17/2001

f461918

To sound the electric horn, press down on the horn button.

1. Horn Button

Fig. 5.15, Electric Horn Control

Powertrain Controls

Powertrain controls are listed here in alphabetical order.

Aftertreatment System Regeneration Switches

NOTE: See [Chapter 11](#) for detailed information about the operation of the regeneration (regen) switches and the aftertreatment system (ATS).

The regen switch ([Fig. 5.16](#)), located on the dash, is used to initiate a parked regen.

When activated, the optional regen-inhibit switch ([Fig. 5.17](#)) stops a regen in progress and prevents the start of a regen until the switch is no longer active.

Axle Switches

NOTE: See [Chapter 15](#) for detailed information about axle switch functions.

Differential Lock Switch

The differential lock provides maximum traction for slippery conditions by forcing the wheels on each drive axle governed by the switch to rotate together.

NOTICE

The differential lock should only be engaged when the vehicle is moving slowly at low throttle. Engagement at high speed or power can damage the axle(s).

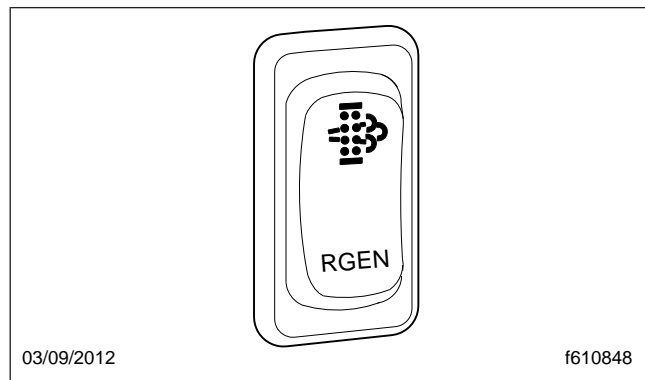

03/09/2012

f610848

Fig. 5.16, Regen Switch

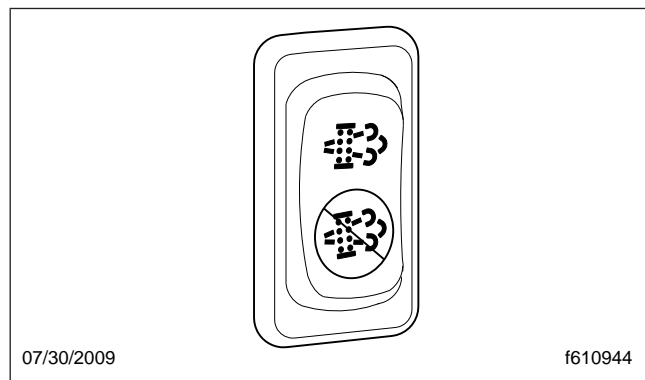

07/30/2009

f610944

Fig. 5.17, Regen-Inhibit Switch

See [Fig. 5.18](#) for the differential lock switch on a vehicle with a single drive axle.

For a vehicle with tandem axles, there are several differential lock switch options available:

- one switch to control the differential lock on only one of the drive axles (this switch will show only one dot on one drive axle, varying slightly from the switch shown in [Fig. 5.19](#)).
- one switch to control the differential locks on both drive axles ([Fig. 5.19](#)).
- two switches, each of which controls the differential lock on one drive axle.

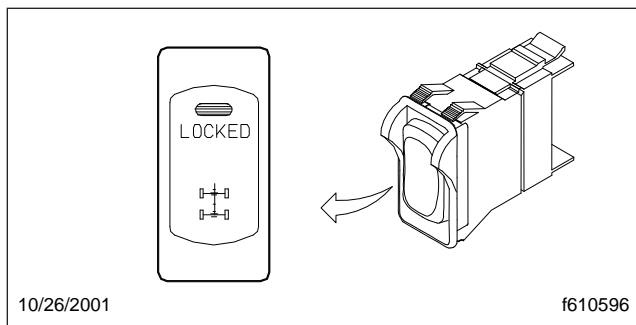

Fig. 5.18, Differential Lock on Single Drive Axle

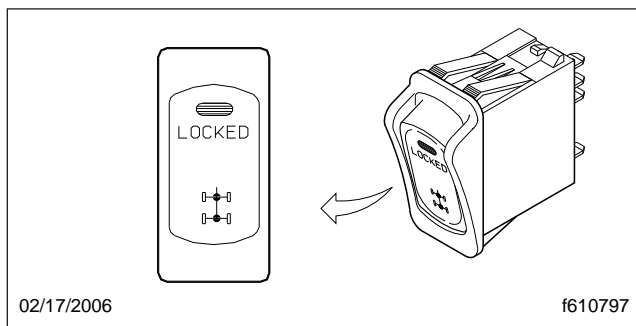

Fig. 5.19, Differential Lock on Both Axles

When the differential lock switch is pressed, the LED in the switch blinks until the differential lock is engaged. When the differential lock is fully engaged, the LED illuminates steadily.

Interaxle Lock Switch

The interaxle lock switch ([Fig. 5.20](#)) allows the driver to lock the drive axles together, causing the drive axle shafts to rotate together. Use this feature only under adverse road conditions where greater traction is needed.

NOTICE

The interaxle lock should only be engaged when the vehicle is moving slowly at low throttle. Engagement at high speed or power can damage the axle(s).

When the interaxle lock switch is pressed, the LED in the switch blinks until the interaxle lock is engaged. When the interaxle lock is fully engaged, the LED illuminates steadily.

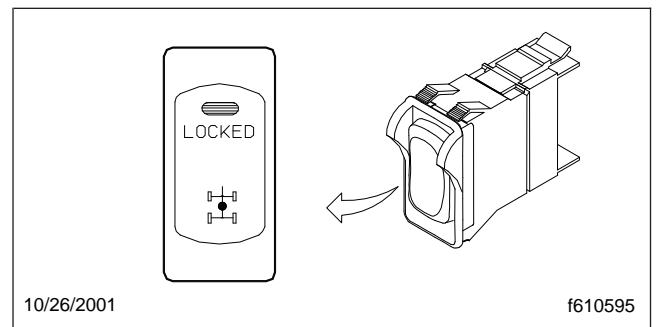

Fig. 5.20, Interaxle Lock Switch

Cruise Control Switches

NOTE: See [Chapter 10](#) for detailed information about cruise control operation.

Cruise control is activated by two dash-mounted switches ([Fig. 5.21](#)).

- On/Off Switch—a two-position rocker labeled SPD CNTL on the lower half of the switch. When cruise control is on, an amber light illuminates the top part of the switch.
- Set/Resume Switch—a three-position paddle switch labeled RES/ACC above the paddle and SET/CST below the paddle.

NOTICE

When the cruise control is engaged, do not attempt to shift gears without using the clutch pedal. Failure to follow this precaution will result in a temporarily uncontrolled increase in engine speed. Transmission damage and gear stripping could result.

Driver Controls

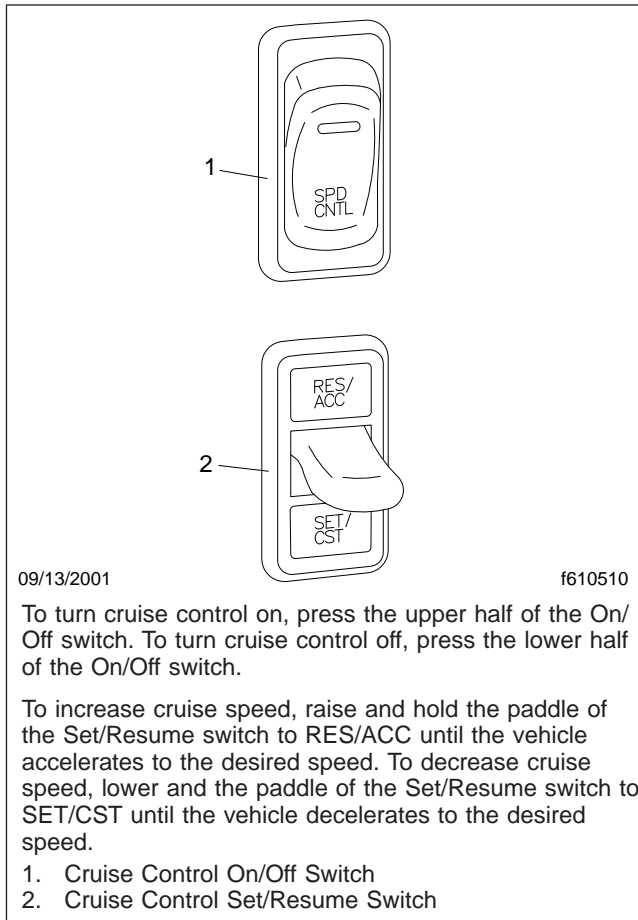

Fig. 5.21, Cruise Control Switches

Engine Brake Switch

NOTE: See [Chapter 10](#) for detailed information about engine brake operation.

Two dash-mounted switches control the engine brake:

- The On/Off switch (ENG BRK), is used to turn the engine brake on and off. See [Fig. 5.22](#).
- The engine brake intensity switch (HI/MED/LO or, in some cases, HI/LO) controls the amount of engine braking.

Engine Fan Switch

The engine cooling fan can be manually activated with the engine fan switch. The fan will continue to operate for a set amount of time and then turn off

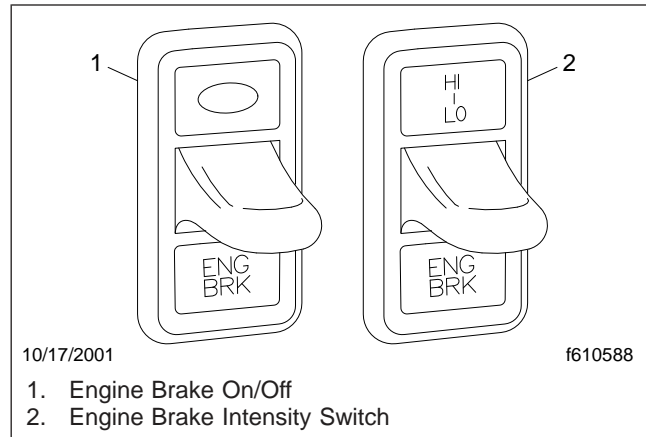

Fig. 5.22, Engine Brake Switches

unless the coolant temperature is high enough to continue the fan operation.

To turn the engine fan on, press the upper part of the rocker switch. See [Fig. 5.23](#). Press the bottom of the switch to deactivate it.

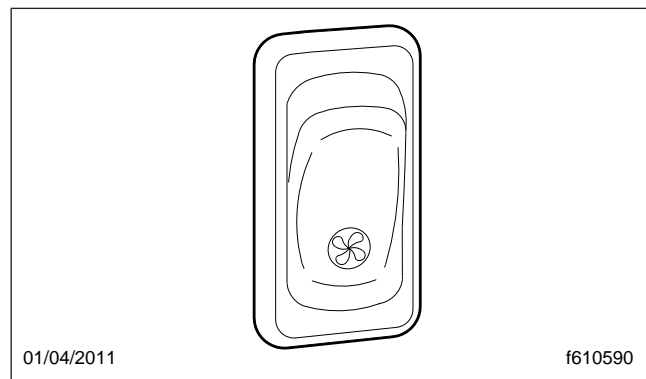

Fig. 5.23, Engine Fan Switch

Exhaust Brake Switch

NOTE: See [Chapter 10](#) for detailed information about exhaust brake operation.

An exhaust brake may be used in conjunction with the service brakes during off-highway and mountain driving as well as in traffic or high-speed highway driving. Exhaust brakes are not intended for use as the primary braking system during vehicle operation.

The exhaust brake is controlled by a dash-mounted rocker switch. See [Fig. 5.24](#) or [Fig. 5.25](#).

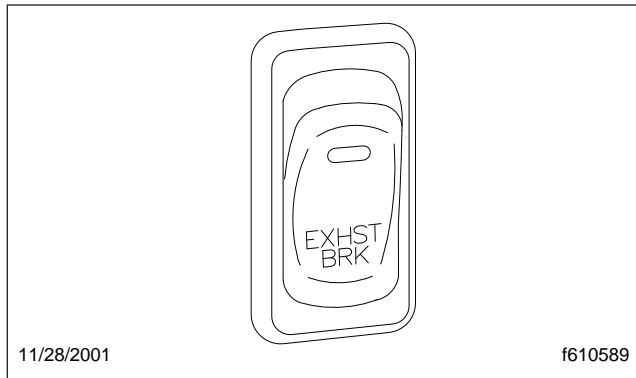

Fig. 5.24, Exhaust Brake Switch

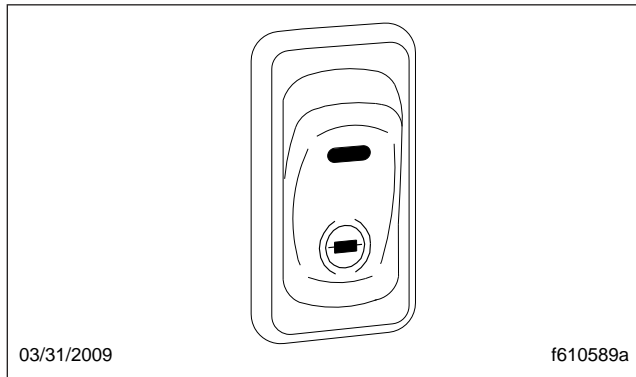

Fig. 5.25, Exhaust Brake Switch

Transmission Controls

Manual Transmissions

NOTE: See [Chapter 13](#) for complete manual transmission operating instructions.

If so equipped, the transmission range control and splitter valves are attached to the gear shift knob.

The range-preselection lever allows the selection of the low or high range for each transmission ratio. It is used once during an upshift sequence and once during a downshift sequence.

Dependent on the transmission model, some ratios can be split using the splitter-control button.

Eaton Automated Transmissions

NOTE: See [Chapter 14](#) for complete automated transmission operating instructions.

The SmartShift electronic transmission control is installed with the Eaton® Fuller® UltraShift™, UltraShift PLUS, and AutoShift™ transmissions. The SmartShift control is operated by the fingers of the driver's right hand, allowing both hands to remain on the steering wheel.

A two-position driving mode slide switch is mounted on the body of the control lever just before the paddle widens out. The slide switch allows the driver to choose automatic (AUTO) or manual (MAN) mode. See [Fig. 5.26](#).

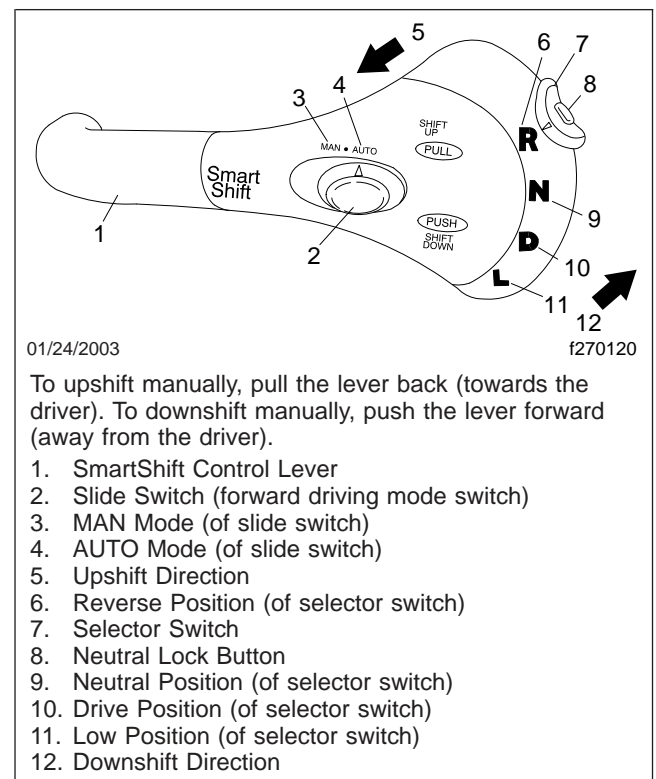

01/24/2003

f270120

To upshift manually, pull the lever back (towards the driver). To downshift manually, push the lever forward (away from the driver).

1. SmartShift Control Lever
2. Slide Switch (forward driving mode switch)
3. MAN Mode (of slide switch)
4. AUTO Mode (of slide switch)
5. Upshift Direction
6. Reverse Position (of selector switch)
7. Selector Switch
8. Neutral Lock Button
9. Neutral Position (of selector switch)
10. Drive Position (of selector switch)
11. Low Position (of selector switch)
12. Downshift Direction

Fig. 5.26, SmartShift Control (Eaton Fuller UltraShift, UltraShift PLUS, and AutoShift transmissions)

Allison Automatic Transmissions

NOTE: See [Chapter 14](#) for complete automatic transmission operating instructions.

Automatic transmissions have up to six forward speeds and one reverse speed. These transmissions have electronic shift controls that can be programmed to allow the use of different geared speeds. See [Fig. 5.27](#).

Driver Controls

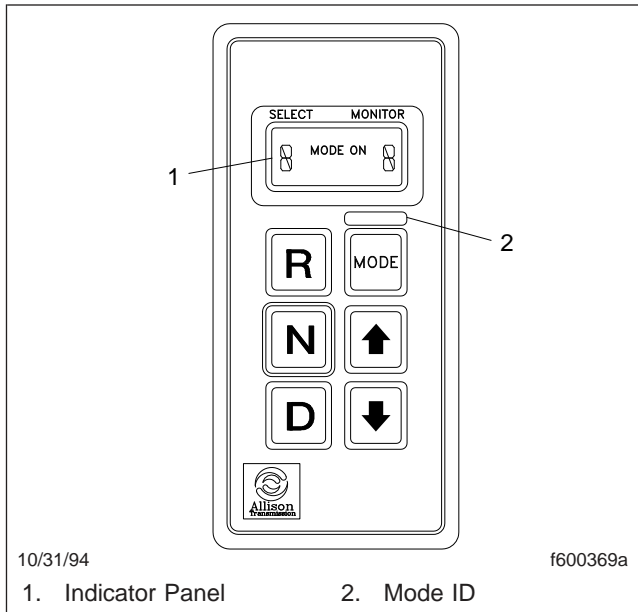

Fig. 5.27, Allison Push Button Shift Selector

All Wheel Drive Controls

All wheel drive (AWD) allows the driver to direct driveline power to all drive and steer axles.

AWD Operation Switch

The AWD operation switch (LOCKED AWD) is a two-position rocker switch. See Fig. 5.28.

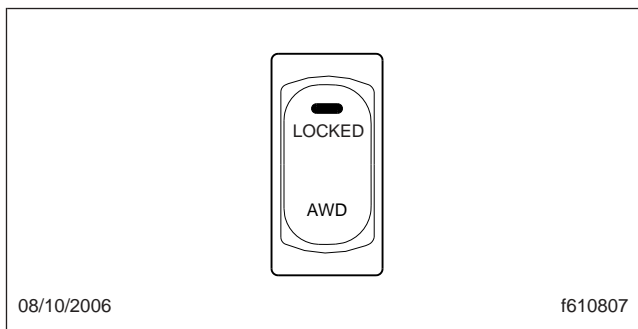

Fig. 5.28, AWD Operation Switch

To engage AWD, press the upper half of the rocker switch. To disengage AWD, press the lower half of the switch.

AWD Range Switch

NOTICE

To prevent damage to the transfer case and the driveline, stop the vehicle and apply the parking brake before using the range switch.

IMPORTANT: Use this switch only when AWD has been engaged.

In most cases, the AWD range switch is a two-position rocker switch with the legend LO RANGE at the upper end and HIGH RANGE at the lower end. On vehicles with a power take-off (PTO) unit, the three-position switch has a neutral (N-TRL) position in the middle. See Fig. 5.29.

Use the AWD high range when driving at normal speeds under off-road conditions or on non-paved surfaces. Use the low range when extra traction is needed at lower speeds (i.e., in muddy, snowy, or icy conditions).

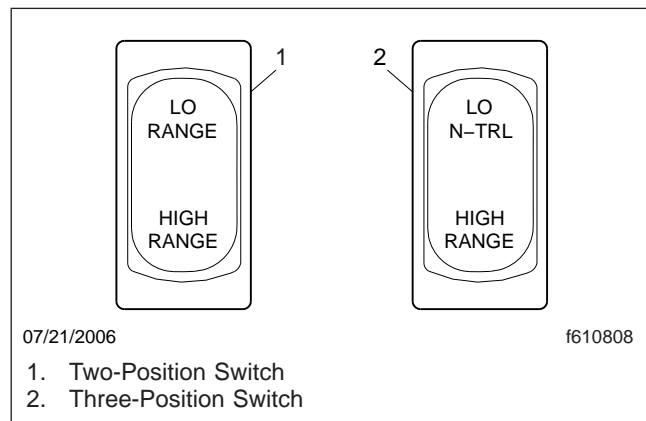

Fig. 5.29, AWD Range Switches

Two-Position Switch (No PTO)

On vehicles without a PTO, high range is considered standard operation. To activate the low range, press the upper half of the switch. To switch back to HIGH RANGE, press the lower half of the switch.

Three-Position Switch (With PTO)

IMPORTANT: Always use the N-TRL range when operating the PTO.

On vehicles with a PTO, neutral is considered standard operation (switch in the middle position).

To activate the high range, press the lower half of the switch. Press the upper half to return to N-TRL.

To activate the low range, press the upper half of the switch. Press the lower half of the switch to return to N-TRL, and then press the lower half again to switch to the high range.

Brake Controls

Parking Brake Control Valve

NOTE: See [Chapter 12](#) for detailed information about brake systems.

NOTICE

Do not step on the service brake pedal while the parking brakes are applied. To do so can cause damage to the brake mechanisms.

The yellow diamond-shaped knob operates the parking brake valve. Pulling the knob out applies both the tractor and trailer spring parking brakes. See [Fig. 5.30](#). Pushing the knob in releases the tractor spring parking brakes.

If the trailer is not equipped with spring parking brakes, pulling out the parking brake valve applies the tractor parking brakes and the trailer service brakes.

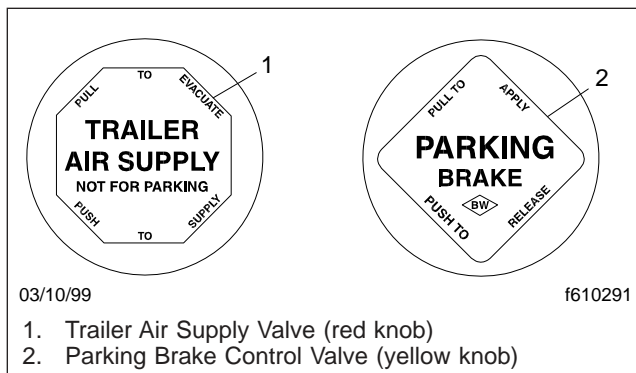

Fig. 5.30, Brake Valve Control Knobs

Trailer Air Supply Valve

The red octagonal-shaped knob operates the trailer air supply valve. See [Fig. 5.30](#). After the vehicle and its air hoses are connected to a trailer and the pressure in the air system is at least 65 psi (447 kPa), push the trailer air supply valve knob in (and leave it

in) to charge the trailer air supply system and release the trailer spring parking brakes.

Pull the trailer air supply valve out before disconnecting a trailer or when operating a vehicle without a trailer.

Trailer Brake Lever

The trailer brake lever is used for applying the trailer service brakes without applying the truck or tractor service brakes. It is usually mounted on the right-hand control panel. See [Fig. 5.31](#). The valve can be partially or fully applied, but in any partially on position it will be overridden by a full application of the service brake pedal. Moving the lever down applies the trailer brakes, while moving it up releases the trailer brakes. The lever will automatically return to the up position when it is released.

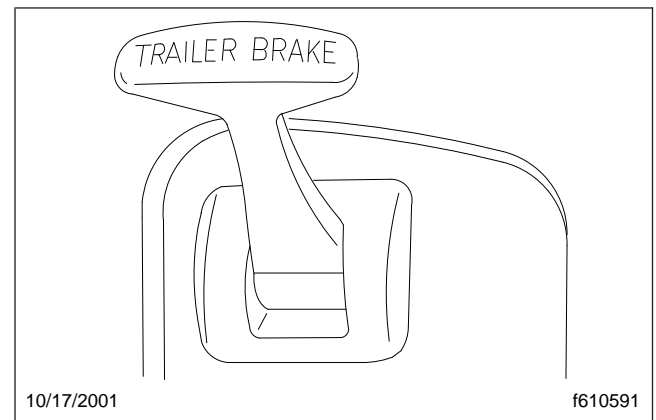

Fig. 5.31, Trailer Brake Lever

Antilock Braking System

The Meritor™ WABCO® Antilock Braking System (ABS) passively monitors vehicle wheel speed at all times, and controls wheel speed during emergency stops or wheel lock situations.

During emergency or reduced-traction stops, fully depress the brake pedal until the vehicle comes to a safe stop. *Do not pump the brake pedal.* With the brake pedal fully depressed, the ABS will control all wheels to provide steering control and a reduced braking distance.

The ABS is designed to communicate with a trailer ABS, if they are compatible. Compatibility will result in the illumination of the TRAILER ABS lamp during vehicle start-up and fault detection. The TRAILER

Driver Controls

ABS lamp will not illuminate unless a compatible trailer is connected to the tractor.

Vehicles with ABS may have Automatic Traction Control (ATC). On these vehicles, the ATC system automatically limits wheel spin during reduced-traction situations. In normal braking applications, the standard air brake system is in effect.

ATC includes a deep snow and mud option to increase available traction on extra-soft surfaces like snow, mud, or gravel. A rocker switch labeled ATC will be located on the dash. Pressing the switch will temporarily allow more drive wheel spin. The activation of the deep snow and mud option is indicated by a flashing WHEEL SPIN lamp. Pressing the switch again will shift the system back to normal operation.

NOTICE

The deep snow and mud option is intended to be used under specific slippery conditions that require momentary increased wheel spin. Using this option for an extended period of time may damage the brake system.

Adjustable Steering Column Controls

Adjust the seat to the desired ride position, then tilt or telescope the steering column as needed.

To tilt the steering column, press down on the foot pedal located on the steering column. Tilt the steering column up or down to the desired position. Release the foot pedal to lock the steering column in place.

To telescope the steering column, press down on the foot pedal located on the steering column. Pull the steering wheel closer to you or push the steering wheel away from you. Release the foot pedal to lock the steering column in place.

Suspension Controls

Other right-hand control panel options are listed here in alphabetical order.

Air Suspension Autofill Override Valve

The suspension autofill override option is a dash air valve ([Fig. 5.32](#)) that keeps the suspension deflated when the ignition is turned off.

To prevent the suspension from filling automatically, turn off the ignition and push the override valve in. When the ignition is turned on, the override valve will release automatically and the suspension will autofill.

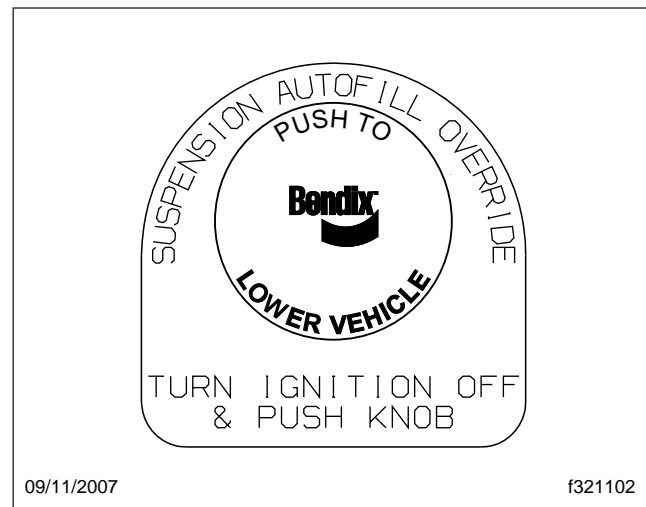

Fig. 5.32, Suspension Autofill Override Valve

Air Suspension Dump Control Switch

NOTICE

Do not operate the vehicle over uneven ground such as ramps, speed bumps, curbs, etc. with the air springs deflated. Doing this may lead to air bag separation from the piston, preventing the suspension air springs from reinflating.

The suspension dump switch is a two-position rocker switch ([Fig. 5.33](#)) that allows the air in the air suspension to be quickly exhausted, lowering the rear of the vehicle. This makes it easier to connect to, or disconnect from, a trailer.

NOTICE

Never exhaust air from the suspension while driving. When the air is exhausted, the suspension will not absorb road shocks and components may be damaged.

To lower the rear of the vehicle, press the upper half of the rocker momentarily. To raise the suspension to its normal height, press the upper half of the rocker again.

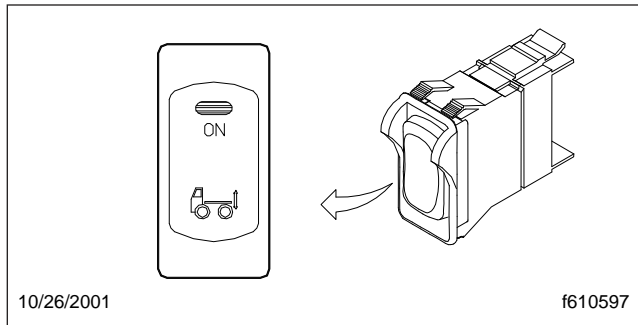

Fig. 5.33, Suspension Dump Switch

When the suspension dump switch is pressed, the LED in the switch blinks while the suspension deflates or fills. When the suspension is completely deflated or filled, the LED illuminates steadily.

If the ignition is turned off while the vehicle is in dump mode, the power to the dump solenoid is cut off to prevent battery drain and the suspension system will autofill. The suspension will also autofill if the vehicle is operated with the suspension dumped at a speed over 5 mph.

Climate Controls

NOTE: See [Chapter 7](#) for detailed climate control panel operating instructions.

The climate control panel without air conditioning is shown in [Fig. 5.34](#). The climate control panel with air conditioning is shown in [Fig. 5.35](#).

The fan switch controls the fan speed and forces fresh or recirculated air through the air outlets.

The air selection switch allows you to control the flow of air through the face outlets, the floor outlets, the defrost (windshield) outlets, or a combination of these outlets.

The temperature control switch is used to select the desired temperature.

The optional recirculation button minimizes the amount of outside air entering the cab. It may be used in dusty or smoky conditions, or when there is a large difference between the outside air temperature and the desired cab temperature. When the recirculation mode is on, the recirculation indicator will illuminate.

Seat Controls

NOTE: See [Chapter 6](#) for detailed information about seat controls and adjustments.

⚠ WARNING

Keep hands, tools, and other objects away from the scissor points under the seats. Failure to do so could cause personal injury.

The following is a description of adjustments that can be made to various seats. Not all seats have all of the adjustments listed below. See [Fig. 5.36](#).

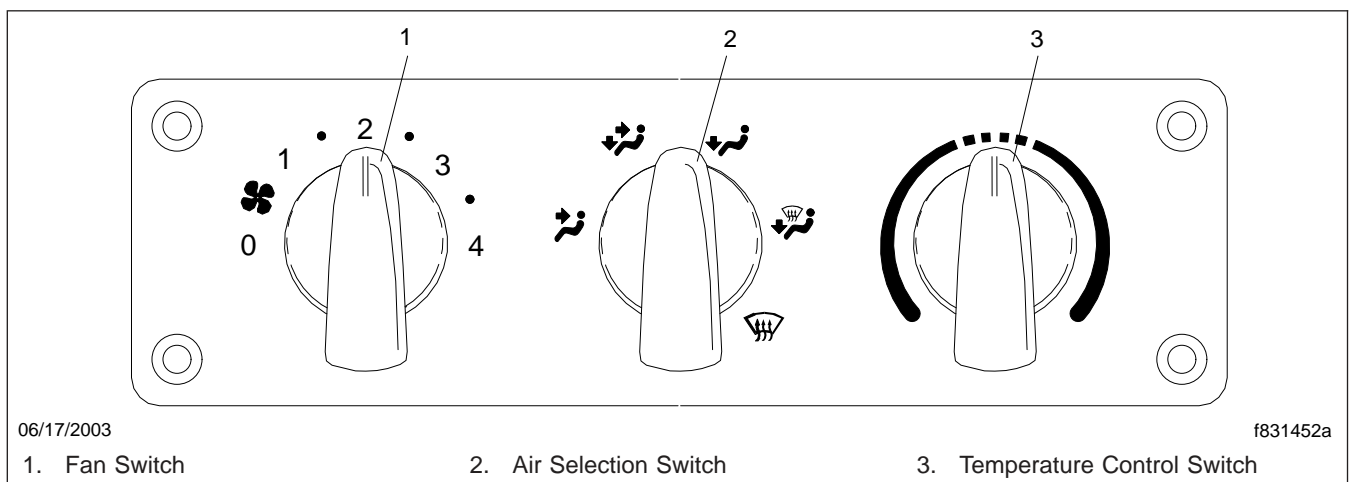

Fig. 5.34, Climate Control Panel Without Air Conditioning

Driver Controls

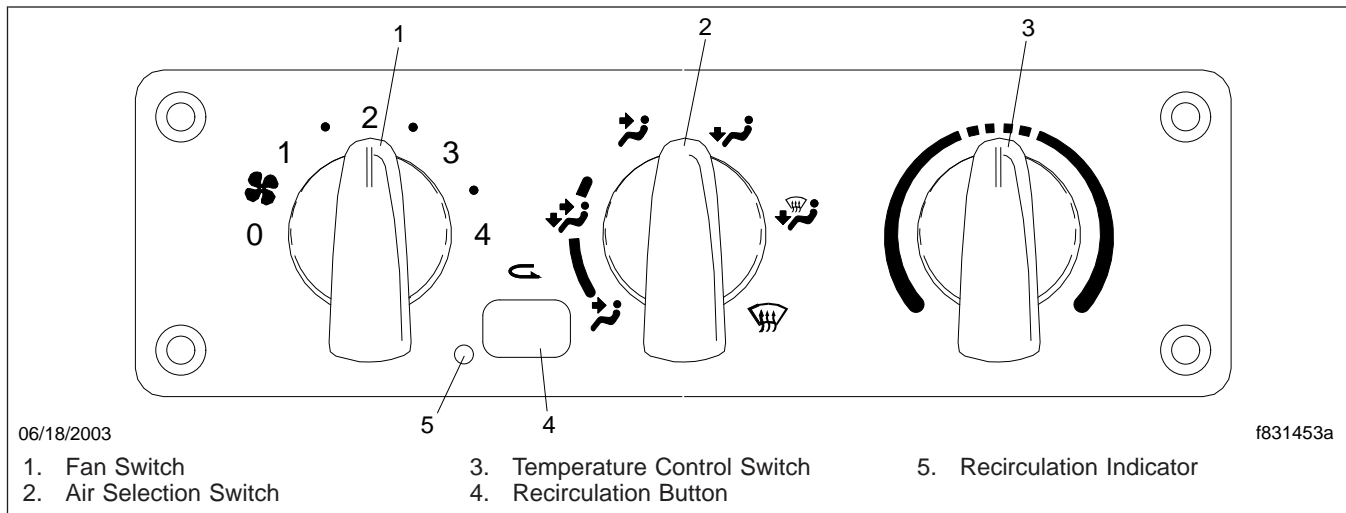

Fig. 5.35, Climate Control Panel With Air Conditioning

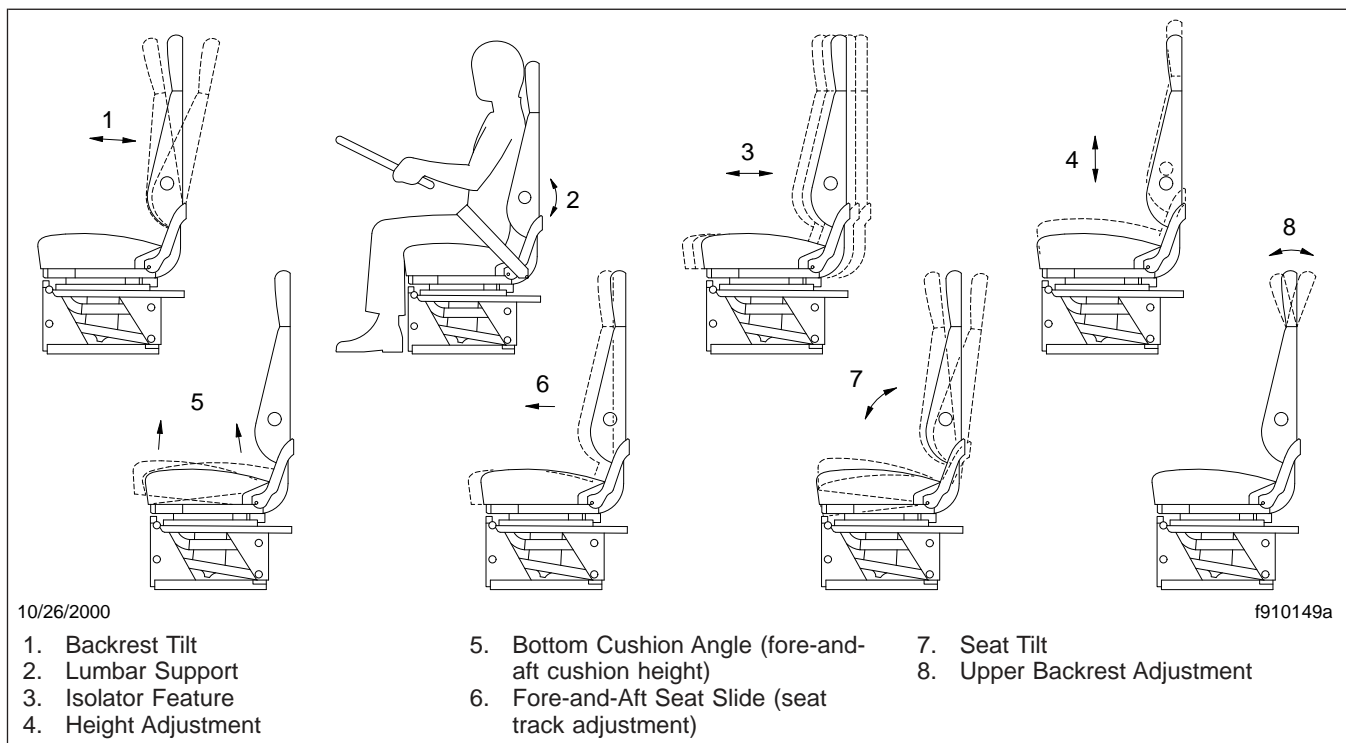

Fig. 5.36, General Seat Adjustments

- Backrest tilt
- Lumbar support
- Isolator
- Height adjustment
- Bottom cushion angle (fore-and-aft bottom cushion height)
- Fore-and-aft seat slide (seat track adjustment)

- Seat tilt
- Headrest adjustment

Bench Seats

The full bench seat ([Fig. 5.37](#)) is optional. The full bench seat has a seat slide adjustment to allow more or less leg room for the driver and passengers. Release the seat slide lever and push backwards or forwards to move the seat along its track.

No adjustments are possible on the two-person bench seat or the non-suspended passenger seat.

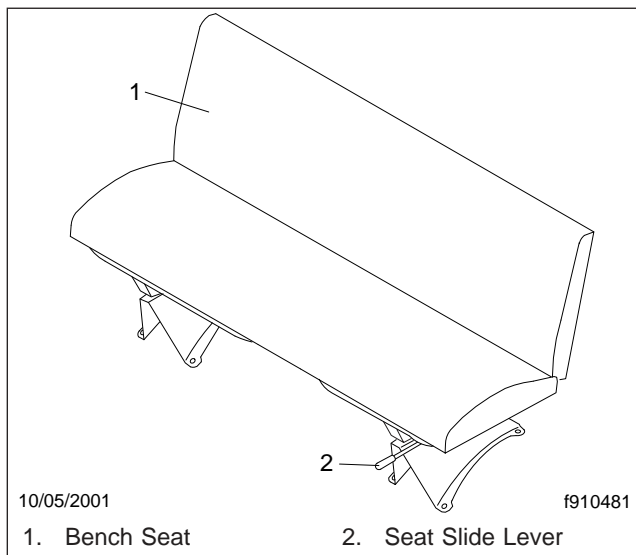

Fig. 5.37, Full Bench Seat

6

Seats and Restraints

Seats, General Information	6.1
Freightliner High-Back Seat	6.2
Bostrom Seat	6.3
Sears Atlas Seat	6.4
National 2000 Series Seat	6.5
Seat Belts and Tether Belts	6.6

Seats and Restraints

Seats, General Information

Unless otherwise noted, all seat adjustments should be made while seated and before the engine is started.

Due to the maximum adjustability of mid- and high-back air suspension seats, it is possible to combine the seat back recline adjustment and the seat slide adjustment so that the seat back contacts the back-wall. It is the responsibility of the driver to adjust the seat to prevent damage to the seat and the cab interior.

WARNING

Keep hands, tools, and other objects away from the scissor points under the seats. Failure to do so could cause personal injury.

The following is a description of adjustments that can be made to various Freightliner-installed seats. Not all seats have all of the adjustments listed below. See [Fig. 6.1](#).

1. Backrest Tilt: This adjustment enables the backrest to pivot forward or backward.
2. Lumbar Support: Lumbar support changes the shape of the seat back to give more or less support to the occupant's lumbar (lower back) area. This adjustment is either mechanical or air controlled, depending on make and model of the seat.
3. Isolator: This feature reduces the amount of road shock by isolating the occupant from the motion of the vehicle, and allowing the upper seat to move in a simple pendulum motion. A lockout feature is used whenever the isolator is not desired.
4. Height Adjustment: This adjustment moves the entire seat up or down. The adjustment is either manually- or air-controlled, depending on the make of the seat.
5. Bottom Cushion Angle, or Fore-and-Aft Bottom Cushion Height: This adjustment enables the occupant to raise or lower the front or back of the

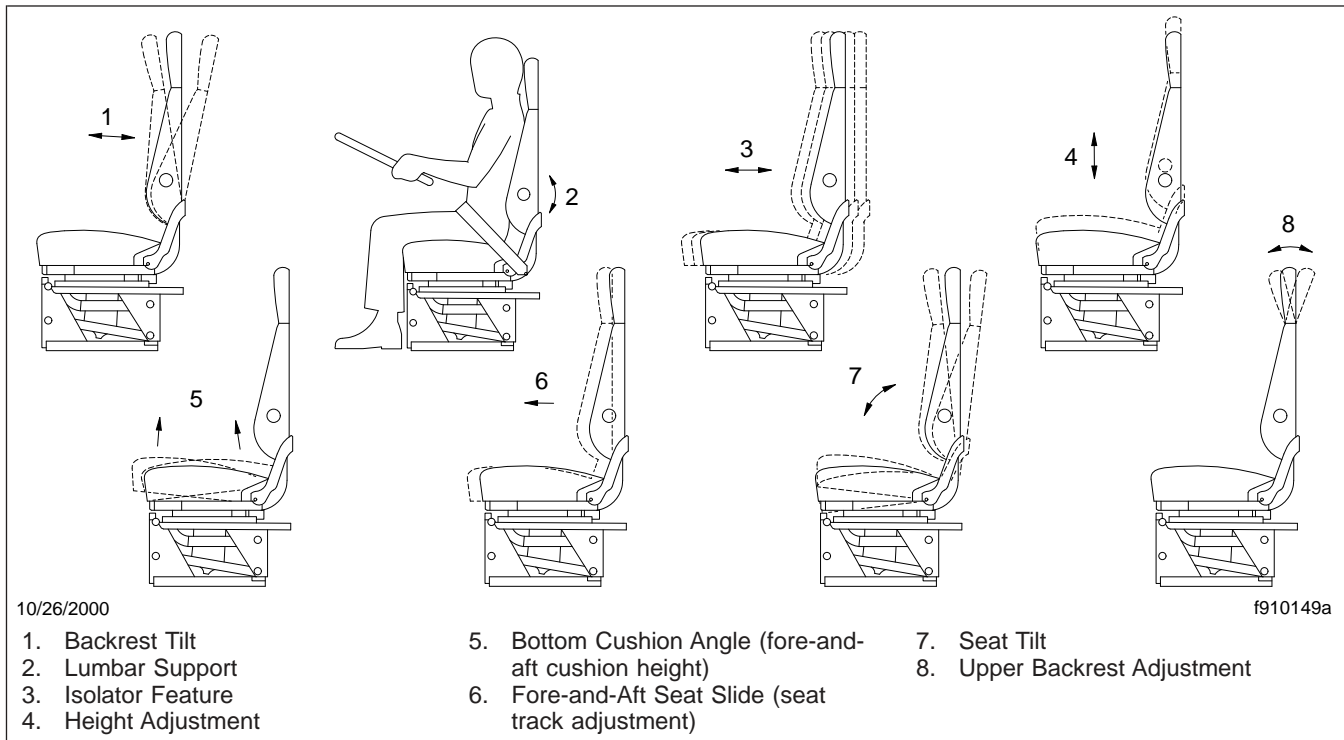

Fig. 6.1, General Seat Adjustments

bottom cushion. This adjustment is easier to perform when all weight is removed from the seat.

6. **Fore-and-Aft Seat Slide, or Seat Track Adjustment:** This adjustment moves the entire seat forward or backward on its track.
7. **Seat Tilt:** This adjustment allows the seat assembly (back and bottom cushions) to tilt forward or backward.
8. **Headrest Adjustment:** This adjustment changes the angle of the upper part of the backrest to provide head and upper back support.

Bench Seats

The full bench seat is optional. See [Fig. 6.2](#).

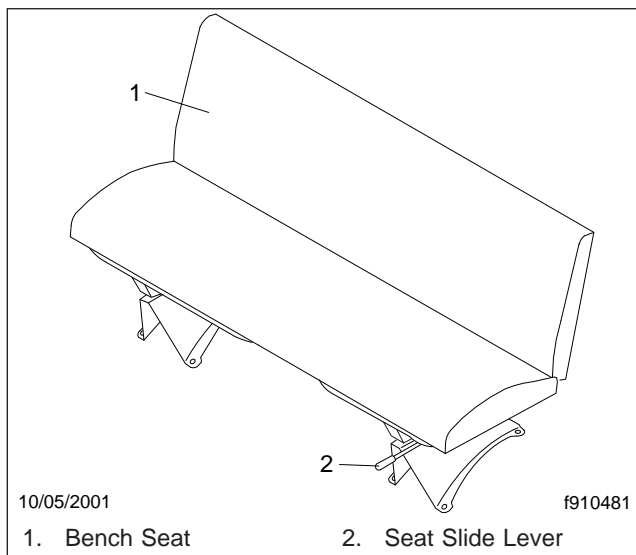

Fig. 6.2, Full Bench Seat

The full bench seat has a seat slide adjustment to allow more or less leg room for the driver and passengers. Release the seat slide lever and push backwards or forwards to move the seat along its track.

High-back air suspension seats are optional for both driver's and passenger's seats. Also available are a non-suspended passenger's seat, and a two-person bench seat with a safe or tool box located under the seat.

No adjustments are possible on the two-person bench seat or the non-suspended passenger seat.

Freightliner High-Back Seat

See [Fig. 6.3](#) for seat adjustment controls. Not all models of the seat have all the adjustments listed below.

Backrest Tilt

To tilt the backrest, lean forward slightly to remove pressure from the cushion, then turn the knob forward or rearward to achieve the desired position.

Lumbar Support

To adjust the lumbar support, use the lumbar support switches on the side of the seat.

Height Adjustment

To raise or lower the height of the seat, use the height adjustment switch on the side of the seat.

Bottom Cushion Extension

To adjust the fore-and-aft position of the seat cushion, remove your weight from the seat, then lift up and pull forward on the cushion adjustment handle. To return the cushion to the aft position, lift up and push rearward.

Fore/Aft Seat Slide

To adjust the fore-and-aft position of the entire seat, move the fore-and-aft seat adjustment lever to the left and slide the seat forward or backward to the desired position. Move the lever back to its original position to lock the seat in place.

Fore/Aft Isolator

To engage the isolator, turn the isolator knob rearward to the unlocked position. Turn the isolator knob forward to the locked position when the isolator feature is not desired.

Shock Absorber

To adjust the amount of damping the shock absorber provides, move the lever up to increase damping; move the lever down to decrease damping.

Seats and Restraints

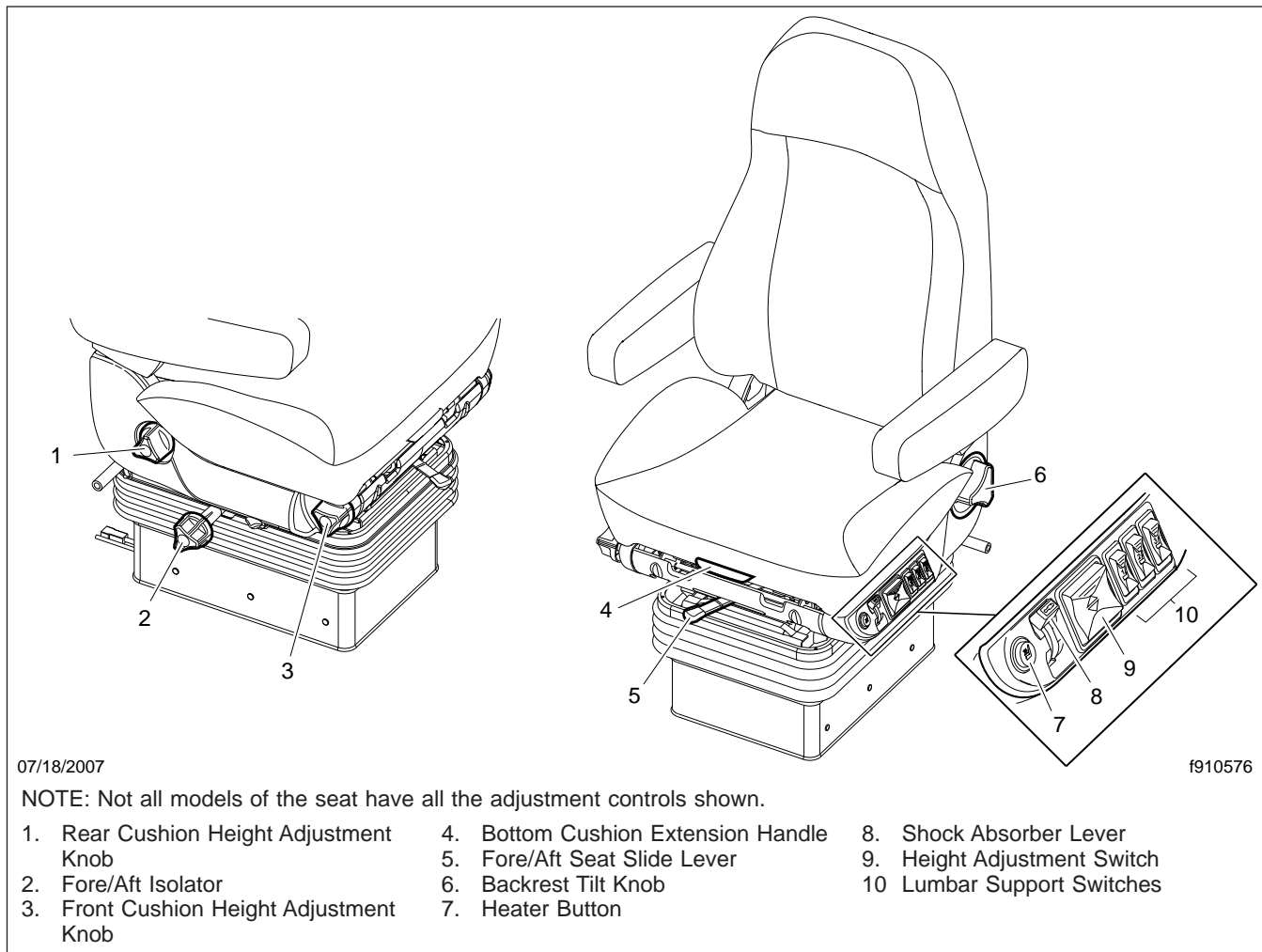

Fig. 6.3, Freightliner High-Back Seat

Front Cushion Height

To adjust the height of the front of the cushion, remove your weight from the seat, then turn the adjustment knob toward the front of the seat (clockwise) to increase cushion height. To lower the cushion height, turn the adjustment knob toward the rear of the seat (counterclockwise).

Rear Cushion Height

To adjust the height of the rear of the seat cushion, remove your weight from the seat and turn the rear cushion adjustment knob to one of three positions.

Heater

To turn on the heat option, press the button. To turn off the heat option, press the button again. If the vehicle has Optimized Idle, seat heating will not operate with the key in accessory mode. Optimized Idle may also turn seat heating off to reduce stress on the batteries.

Bostrom Seat

See [Fig. 6.4](#) for Bostrom seat adjustment controls.

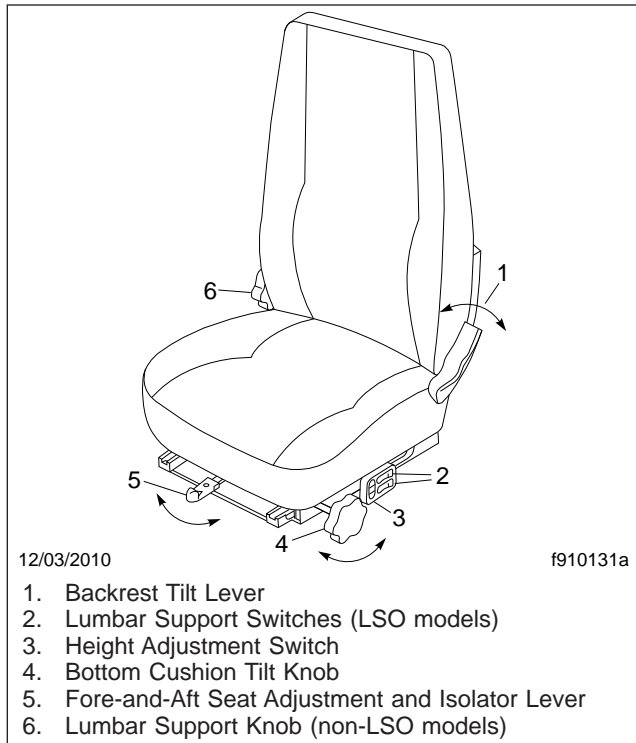

Fig. 6.4, Bostrom Seat Adjustment Controls

Backrest Tilt, Bostrom Seat

To tilt the backrest, lean forward slightly to remove pressure from the cushion and hold the backrest tilt lever rearward. Lean backward slowly to the desired position and release the lever to lock the backrest in place. To adjust backrest forward, hold the backrest tilt lever rearward while leaning forward.

Lumbar Support, Bostrom Seat

To increase lumbar support on luxury seat option (LSO) models, press the plus sign on the lumbar support switch. To decrease lumbar support on LSO models, press the minus sign on the switch.

To increase lumbar support on non-LSO models, rotate the lumbar support knob forward. To decrease lumbar support on non-LSO models, rotate the knob rearward.

Height Adjustment, Bostrom Seat

To raise the seat, press the upper portion of the height adjustment switch. To lower the seat, press the lower portion of the switch.

Bottom Cushion Tilt, Bostrom Seat

To adjust the bottom cushion tilt, rotate the bottom cushion tilt knob to increase or decrease bottom cushion tilt.

Fore-and-Aft Seat Adjustment, Bostrom Seat

To adjust the fore-and-aft position of the entire seat, hold the fore-and-aft adjustment lever to the left and slide the seat forward or backward to the desired position.

Isolator, Bostrom Seat

To engage the isolator, put the isolator lever in the center position. Lock out the isolator by moving the lever to the right.

Sears Atlas Seat

See [Fig. 6.5](#) for seat adjustment controls.

Seat Tilt/Extension Adjustment, Sears Atlas Seat

To adjust the seat tilt/extension, lift the handle upward and move the seat cushion to the desired position. Three positions are available.

Fore-and-Aft Seat Adjustment, Sears Atlas Seat

To adjust the fore-and-aft position of the entire seat, lift the bar and slide the seat to the desired position.

Isolator

To engage the isolator, put the isolator lever in the left position. Lock out the isolator by moving the lever to the right.

Height Adjustment, Sears Atlas Seat

To inflate and raise the suspension, push forward on the front rocker switch. To deflate and lower the suspension, push rearward to deflate and lower the suspension.

Seats and Restraints

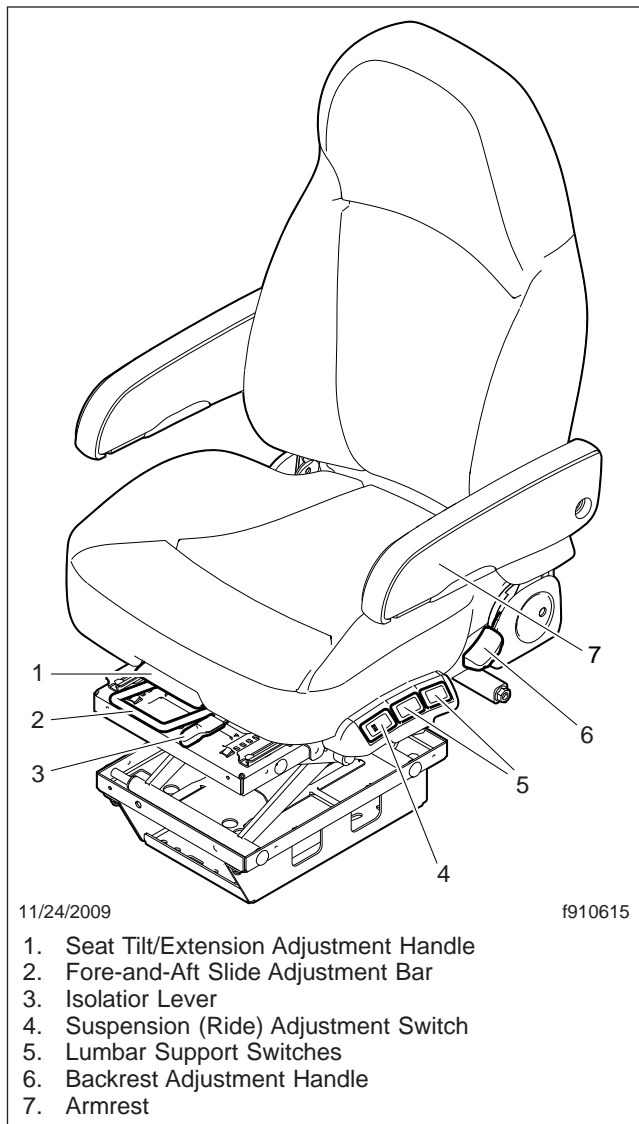

Fig. 6.5, Sears Atlas Seat Adjustment Controls

Lumbar Support, Sears Atlas Seat

To inflate or deflate the lower lumbar bag, push the rear rocker switch.

to inflate or deflate the upper lumbar bag, push the center rocker switch.

Backrest Tilt, Sears Atlas Seat

To tilt the backrest, lean forward slightly to remove pressure from the cushion and pull upward on the backrest adjustment handle. Lean backward slowly to

the desired position and release the lever to lock the backrest in place. To adjust backrest forward, pull upward on the recliner handle while leaning forward.

Armrest Adjustment, Sears Atlas Seat

To adjust the armrest the the desired angle, rotate the control knob (located on the underside of the armrest).

National 2000 Series Seat

See [Fig. 6.6](#) for seat adjustment controls.

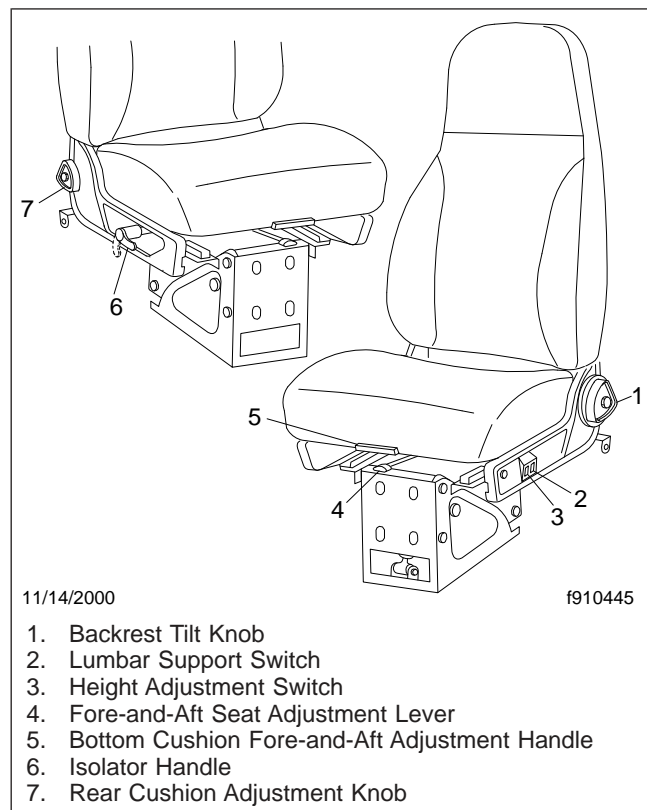

Fig. 6.6, National 2000 Series Seat Adjustment Controls

Backrest Tilt, National 2000 Series Seat

To tilt the backrest, turn the backrest tilt knob until the desired position is reached.

Lumbar Support, National 2000 Series Seat

To adjust the lumbar support, use the lumbar support switch on the side of the seat to give more or less support to your lower back.

Height Adjustment, National 2000 Series Seat

To raise or lower the height of the seat, use the height adjustment switch on the side of the seat.

Fore-and-Aft Seat Adjustment, National 2000 Series Seat

To adjust the fore-and-aft position of the entire seat, move the fore-and-aft seat adjustment lever to the left and slide the seat forward or backward to the desired position. Move the lever back to its original position to lock the seat in place.

Bottom Cushion Fore-and-Aft Adjustment, National 2000 Series Seat

To adjust just bottom cushion, lift the bottom cushion adjustment handle and pull forward or push back to the desired setting.

Isolator, National 2000 Series Seat

To engage the isolator, turn the isolator handle to the horizontal position. Lock out the isolator by turning the isolator handle down.

Rear Cushion Adjustment, National 2000 Series Seat

To adjust the height of the rear of the seat cushion, remove your weight from the seat and turn the rear cushion adjustment knob to one of three positions.

Seat Belts and Tether Belts

General Information, Seat Belts and Tether Belts

Seat belt assemblies are designed to secure persons in the vehicle to help reduce the chance of injury, or the amount of injury, resulting from accidents or sud-

den stops. For this reason, Daimler Trucks North America LLC urges that the driver and *all* passengers, regardless of age or physical condition, use seat belts when riding in the vehicle.



Always use the vehicle's seat belt system when operating the vehicle. Failure to do so can result in severe personal injury or death.

Seat belt assemblies in Daimler Trucks North America (DTNA) vehicles meet Federal Motor Vehicle Safety Standard 209, "Type 1" and "Type 2" requirements.

When transporting a child, always use a child restraint system or the vehicle seat belts as appropriate. To determine whether a child restraint system is required, review and comply with applicable state and local laws. Any child restraint used must comply with Federal Motor Vehicle Safety Standard 213, "Child Restraint Systems." When providing a child restraint system, always carefully read and follow all instructions pertaining to installation and usage for the child. Make certain the child remains in the restraint system at all times when the vehicle is in motion.

In addition to seat belt assemblies, tether belts are installed on suspension-type seats. Tether belts provide a flexible extension of the cab structure. They help secure the seat to the floor, and are intended to restrain the seat and seat belt in case of an accident or sudden stop.

IMPORTANT: Seat belts and tethers have a finite life which may be much shorter than the life of the vehicle. Regular inspections and replacement as needed are the only assurance of adequate seat belt security over the life of the vehicle.

Inspection, Seat Belts and Tether Belts



Inspect and maintain seat belts. When any part of a seat belt system needs replacement, the entire seat belt must be replaced, both retractor and buckle side. Any time a vehicle is involved in an accident, and the seat belt system was in use,

Seats and Restraints

the entire vehicle seat belt system must be replaced before operating the vehicle. Do not attempt to modify the seat belt system; doing so could change the effectiveness of the system. Failure to replace worn or damaged seat belts, or making any modifications to the system, may result in personal injury or death.

Inspect the seat belts and tether belts (if so equipped).

1. Check the web for fraying, cuts, extreme dirt and dust, or for severe fading from exposure to sunlight, especially near the buckle latch plate and in the D-loop guide area.
2. Check operation of the buckle, latch, Komfort Latch or Sliding Komfort Latch (if equipped), web retractor, and upper seat belt mount on the door pillar. Check all visible components for wear or damage.
3. Check the seat belt and tether belt connection points and tighten any that are loose.

Seat Belt Operation

Three-Point Seat Belt With Komfort Latch or Sliding Komfort Latch

NOTE: For vehicles not equipped with the Komfort Latch or the Sliding Komfort Latch, see the seat belt operation under the heading "Three-Point Seat Belt."

WARNING

Wear three-point seat belts only as described below. Three-point seat belts are designed to be worn by one person at a time. In case of an accident or sudden stop, personal injury or death could result from misuse.

Fasten the seat belts before driving. Fastening a three-point seat belt while driving creates a hazard.

When engaged and used properly, the Komfort Latch (Fig. 6.7) and the Sliding Komfort Latch (Fig. 6.8) introduce a small amount of slack into the seat belt, resulting in a more comfortable ride.

1. Slowly pull the latch end of the three-point seat belt out of the retractor and pull it across your lap (from outboard to inboard) far enough to en-

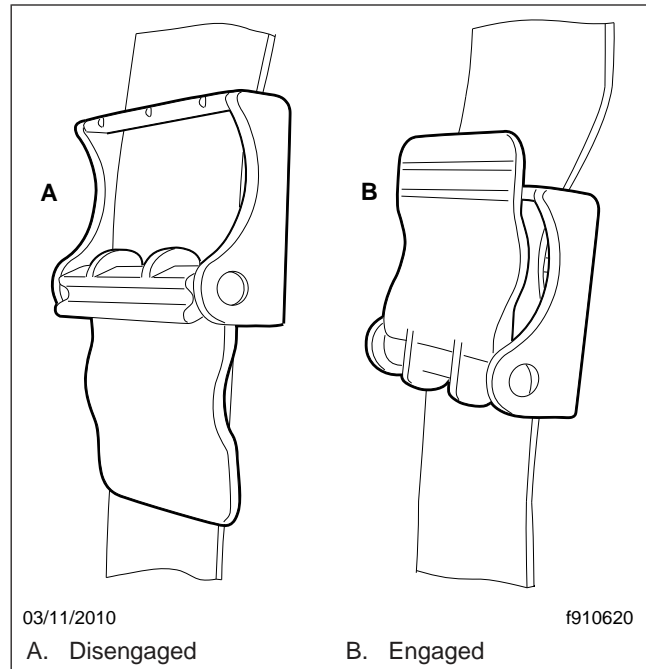

Fig. 6.7, Komfort Latch



Fig. 6.8, Sliding Komfort Latch

gage the buckle. If the retractor locks too soon, allow the belt to retract slightly, then slowly pull it out again. See Fig. 6.9.

2. Fasten the three-point seat belt by pushing the latch into the buckle. Listen for an audible click.

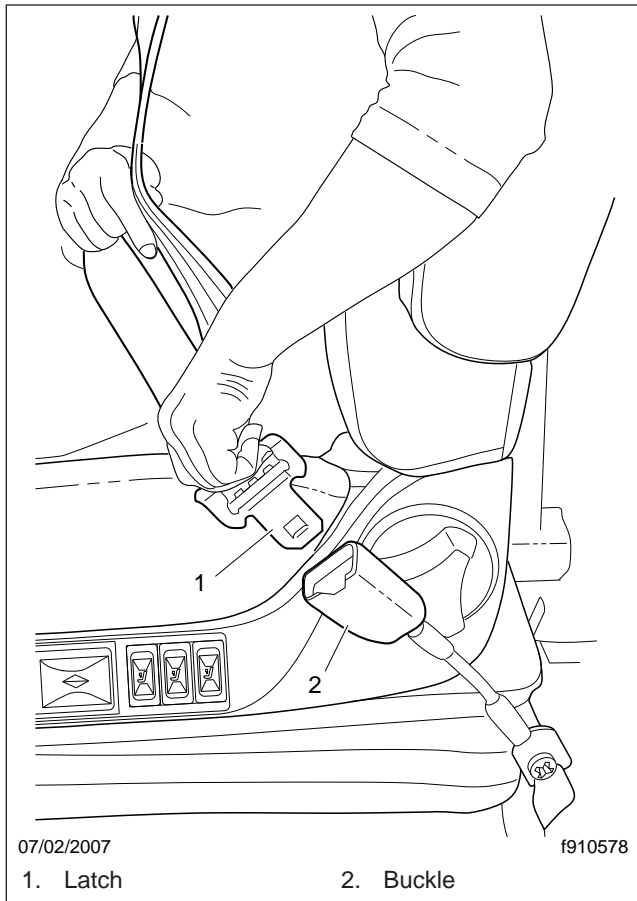

Fig. 6.9, Three-Point Seat Belt Operation

3. Tug on the seat belt to make sure it is securely fastened. If the buckle unlatches, repeat this step. If the problem continues, replace the three-point seat belt.
4. Snug the seat belt to your waist.

WARNING

Before activating the Komfort Latch or the Sliding Komfort Latch, make sure the amount of slack in the shoulder strap is set as described below. Excess slack in the shoulder strap reduces the effectiveness of the seat belt, and increases the risk of injury or death in an accident.

5. Position the shoulder strap diagonally across your chest with the adjustable D-loop bracket (if equipped). The shoulder strap must be centered on your shoulder and chest, away from your face

and neck. See **Fig. 6.10**. If desired, engage the Komfort Latch or Sliding Komfort Latch as follows.

*If equipped with a Sliding Komfort Latch, make sure that the shoulder strap is snug against your chest. Without loosening the shoulder strap, push the Sliding Komfort Latch switch to the "ON" position. See **Fig. 6.8**. To activate the latch lean forward until you hear a click. This will allow for approximately 1 inch (2.5 cm) of slack between your chest and the shoulder harness. Once engaged, the latch will allow you to lean forward about 5 inches (13 cm) without having to reset the latch. Leaning forward more than 5 inches (13 cm) will disengage the Sliding Komfort Latch, requiring it to be reset.*

*If equipped with a Komfort Latch, pull on the shoulder strap to lessen the pressure of the strap on your shoulder and chest. Allow no more than 1 inch (2.5 cm) of slack between your chest and the shoulder harness. More slack can significantly reduce the seat belt effectiveness in an accident or a sudden stop. While holding the belt slack, press the Komfort Latch lever up, clamping the seat belt webbing (**Fig. 6.11** and **Fig. 6.12**).*

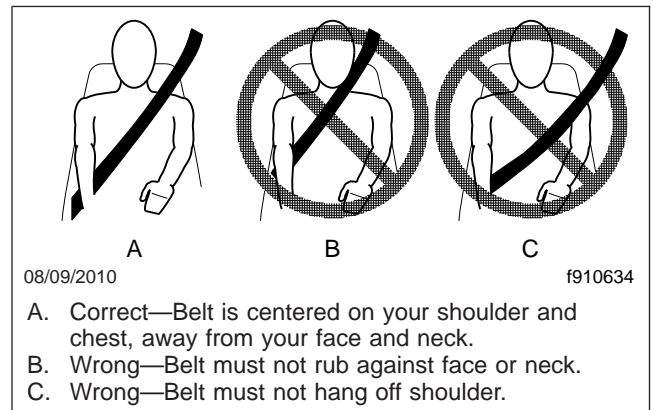

Fig. 6.10, Proper Shoulder Strap Fit

6. Unbuckle the three-point seat belt and release the Komfort Latch or the Sliding Komfort Latch as follows.

If equipped with a Sliding Komfort Latch, unbuckle the seat belt, then tug on the shoulder belt to release the Sliding Komfort Latch, or press the Sliding Komfort latch to the "OFF" position, then unbuckle the seat belt.

Seats and Restraints

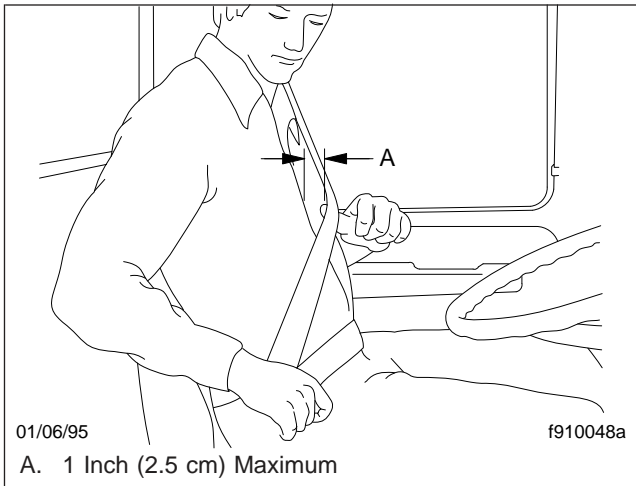

Fig. 6.11, Adjusting Shoulder Harness Clearance, Komfort Latch

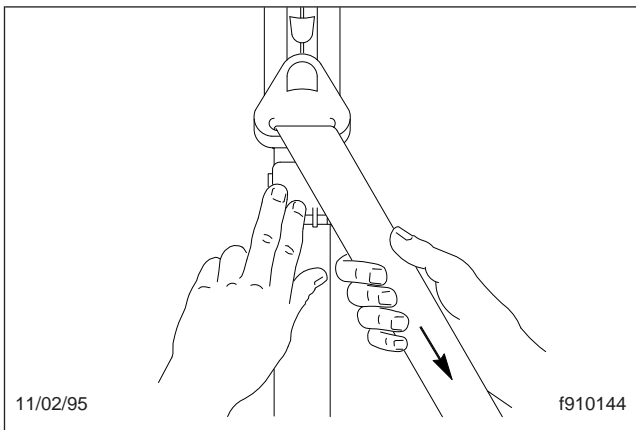

Fig. 6.12, Locking the Komfort Latch

If equipped with a Komfort Latch, unbuckle the seat belt, then release the Komfort Latch by giving the shoulder belt a quick tug. If you lean forward against the shoulder belt, the Komfort Latch will automatically release, and will need to be reset.

NOTE: Neither the Komfort Latch nor the Sliding Komfort Latch need to be manually released in an emergency situation. Each will release by itself under rough road or other abnormal conditions. Make sure the three-point seat belt is completely retracted when it is not in use.

Three-Point Seat Belt

NOTE: For vehicles equipped with the Komfort Latch or the Sliding Komfort Latch, see the seat belt operation under the heading "Three-Point Seat Belt With Komfort Latch or Sliding Komfort Latch."

WARNING

Wear three-point seat belts only as described below. Three-point seat belts are designed to be worn by one person at a time. In case of an accident or sudden stop, personal injury or death could result from misuse.

Fasten the seat belts before driving. Fastening a three-point seat belt while driving creates a hazard.

1. Slowly pull the link end of the three-point seat belt out of the retractor and pull it across your lap (from outboard to inboard) far enough to engage the buckle. If the retractor locks too soon, allow the belt to retract slightly, then slowly pull it out again. See [Fig. 6.8](#).
2. Fasten the three-point seat belt by pushing the latch into the buckle. Listen for an audible click.
3. Tug on the seat belt to make sure it is securely fastened. If the buckle unlatches, repeat this step. If the problem continues, replace the three-point seat belt.
4. Snug the seat belt to your waist.
5. Position the shoulder strap diagonally across your chest with the adjustable D-loop bracket (if equipped). The shoulder strap must be centered on your shoulder and chest, away from your face and neck. See [Fig. 6.10](#).
6. To unbuckle the three-point seat belt, press the release button on the buckle.

NOTE: Make sure the three-point seat belt is completely retracted when it is not in use.

7

Climate Control

Climate Control Panel	7.1
-----------------------------	-----

Climate Control

Climate Control Panel

The climate control panel allows you to control the heating, ventilating, defrosting, and air conditioning functions. The climate control panel without air conditioning is shown in [Fig. 7.1](#). The climate control panel with air conditioning is shown in [Fig. 7.2](#).

Fan Switch

The fan switch controls the fan speed and forces fresh or recirculated air through the air outlets. The fan switch has eight fan speeds and an off position.

To increase airflow, turn the fan switch to the right toward a higher number. To decrease the airflow, turn the switch to the left toward a lower number.

Air Selection Switch

The air selection switch allows you to control the flow of air through the face outlets, the floor outlets, the defrost (windshield) outlets, or a combination of these outlets to give you nine air selection modes on a system without air conditioning. See [Fig. 7.3](#). A system with air conditioning has eleven air selection

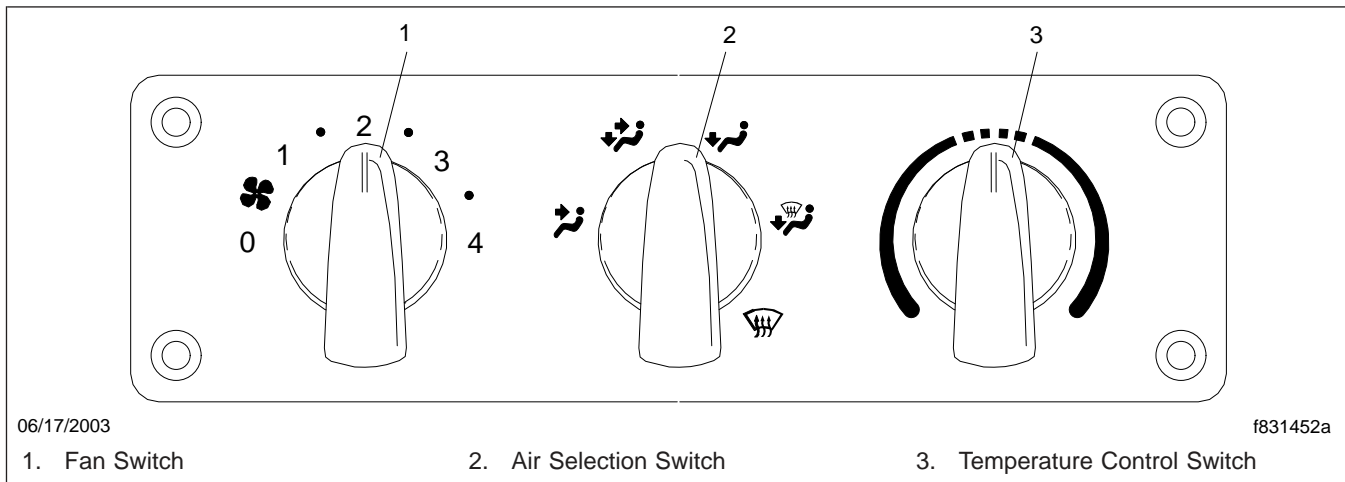

Fig. 7.1, Climate Control Panel Without Air Conditioning

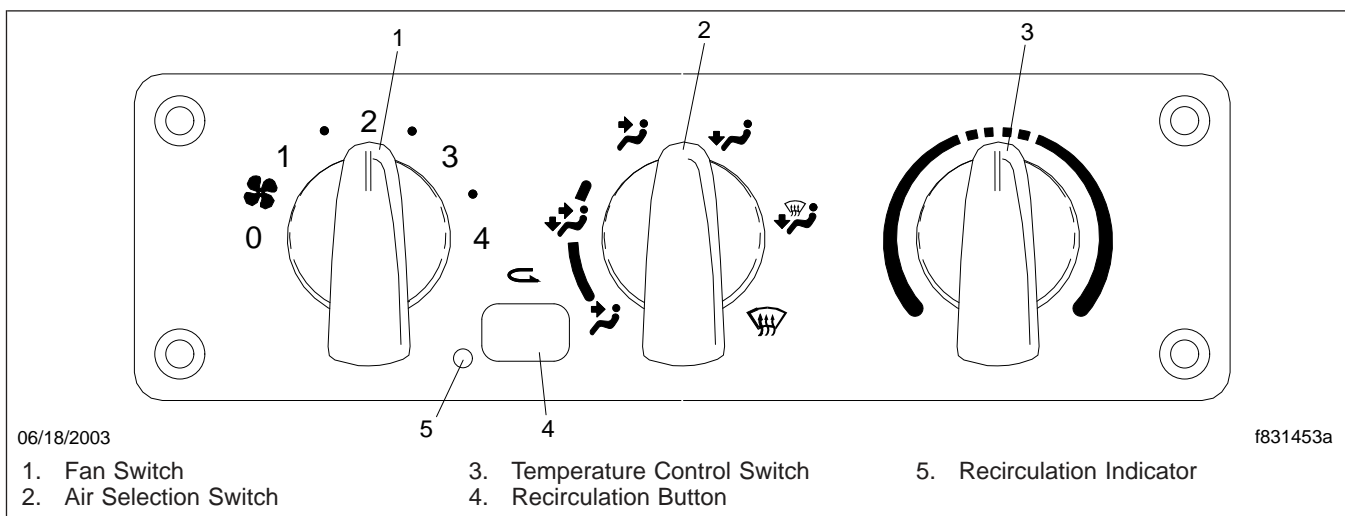

Fig. 7.2, Climate Control Panel With Air Conditioning

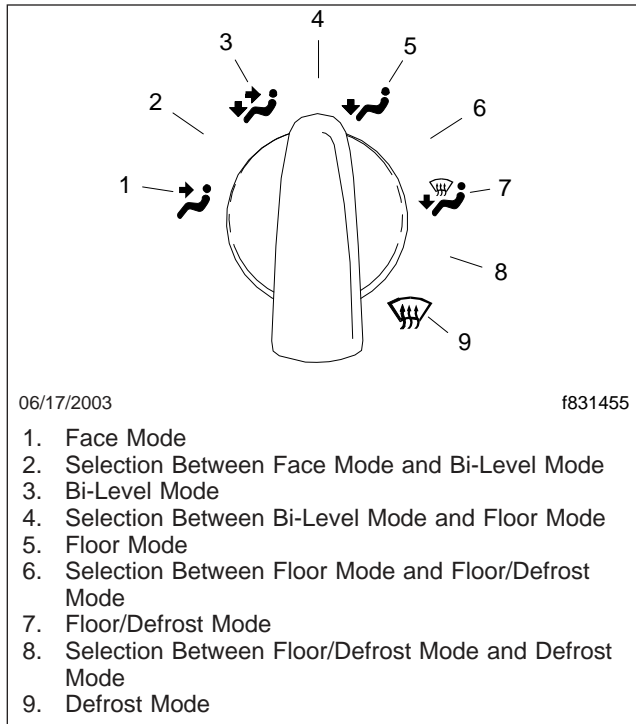

Fig. 7.3, Air Selection Switch Without Air Conditioning

modes, four of which are air conditioning modes. See [Fig. 7.4](#).

Air Selection Switch Without Air Conditioning

1. **Face Mode:** Directs all airflow through the face or instrument panel outlets.
2. **Selection between Face Mode and Bi-Level Mode:** Directs 75 percent of the airflow through the face outlets and 25 percent through the floor outlets.
3. **Bi-Level Mode:** Directs the airflow equally to the face outlets and the floor outlets.
4. **Selection between Bi-Level Mode and Floor Mode:** Directs 25 percent of the airflow through the face outlets and 75 percent through the floor outlets.
5. **Floor Mode:** Directs all airflow through the floor outlets.
6. **Selection between Floor Mode and Floor/Defrost Mode:** Directs 75 percent of the airflow

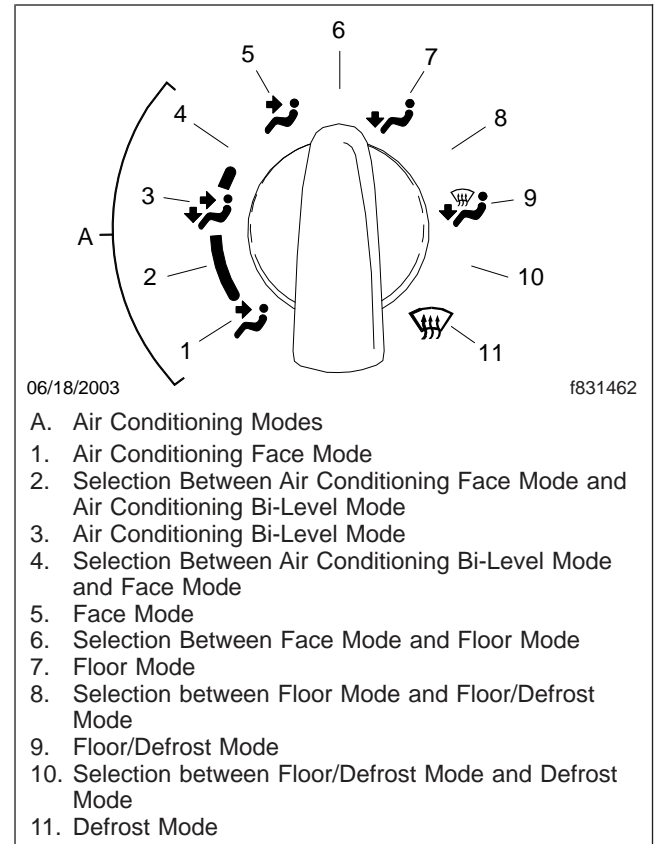

Fig. 7.4, Air Selection Switch With Air Conditioning

through the floor outlets and 25 percent through the defrost outlets.

7. **Floor/Defrost Mode:** Directs the airflow equally to the floor outlets and the defrost outlets.
8. **Selection between Floor/Defrost Mode and Defrost Mode:** Directs 75 percent of the airflow through the defrost outlets and 25 percent through the floor outlets.
9. **Defrost Mode:** Directs all airflow through the defrost outlets.

Air Selection Switch With Air Conditioning

1. **Air Conditioning Face Mode:** Directs all airflow through the face or instrument panel outlets.
2. **Selection between the Air Conditioning Face Mode and the Air Conditioning Bi-Level**

Climate Control

Mode: Directs 75 percent of the airflow to the face outlets and 25 percent to the floor outlets.

3. **Air Conditioning Bi-Level Mode:** Directs the airflow equally to the face outlets and the floor outlets.
4. **Selection between the Air Conditioning Bi-Level Mode and the Face Mode:** Directs 25 percent of the airflow to the face outlets and 75 percent to the floor outlets.
5. **Face Mode:** Directs all airflow through the face outlets.
6. **Selection between Face Mode and Floor Mode:** Directs the airflow equally through the face outlets and the floor outlets.
7. **Floor Mode:** Directs all airflow through the floor outlets.
8. **Selection between Floor Mode and Floor/Defrost Mode:** Directs 75 percent of the airflow through the floor outlets and 25 percent through the defrost outlets.
9. **Floor/Defrost Mode:** Directs the airflow equally to the floor outlets and the defrost outlets. The recirculation button will not work in this mode.
10. **Selection between Floor/Defrost Mode and Defrost Mode:** Directs 75 percent of the airflow through the defrost outlets and 25 percent through the floor outlets. The recirculation button will not work in this mode.
11. **Defrost Mode:** Directs all airflow through the defrost outlets. The recirculation button will not work in this mode.

Temperature Control Switch

The temperature control switch is used to select the desired temperature. Turn the switch to the left (counterclockwise) for cool air, or to the right (clockwise) for hot air. There are 21 positions on the temperature control switch ranging from full cool air to full hot air.

Fresh Air Mode

Fresh air, or outside air, is circulated through the heating and air conditioning system unless the recirculation mode, if equipped, is turned on.

Recirculation Mode

The recirculation mode is only available on vehicles with air conditioning.

The recirculation mode limits the amount of outside air entering the cab. Press the recirculation button to prevent dusty or smoky air from entering the cab. The recirculation mode can also be used to decrease the time required to cool or heat the cab interior during extreme outside temperature conditions. When the recirculation mode is on, the recirculation indicator will illuminate. See [Fig. 7.2](#).

The recirculation mode is not available when the air selection switch is in one of the following modes:

- floor/defrost mode
- selection between floor/defrost mode and defrost mode
- defrost mode

When the recirculation mode is turned on, it will stay on for 20 minutes, or until the recirculation button is pressed again, or the air selection switch is turned to a defrost mode.

IMPORTANT: The system will enter a partial recirculation mode for five minutes after being in full recirculation mode for twenty minutes. This cycle will repeat as long as the system is in recirculation mode.

Defrosting

Before using any of the defrost modes, clear the screen at the base of the windshield of any ice or snow.

Air Conditioning, Optional

The four air conditioning settings on the air selection switch, as well as the selection between the air conditioning bi-level mode and the face mode, are blue.

NOTE: The heating and air conditioning system has a brushless blower motor with a protection or shutdown mode to prevent damage due to overheating and overcurrent conditions. If the brushless blower motor goes into protection mode, the motor will operate at a slower speed. If the overheating or overcurrent condition continues, the motor will shut down and stop completely.

The motor will resume proper operation after the motor has cooled or the overcurrent condition has been resolved. It will be necessary to cycle the fan switch off and then on, to reset the motor. If the problem appears repeatedly, take the vehicle to a Freightliner dealer or authorized service outlet for repairs.

Accessory Heaters

Optional accessory heaters are available from the factory in several configurations. Familiarize yourself with the equipment on your specific vehicle, and follow the manufacturer's operating and maintenance instructions.

 WARNING
--

Do not operate fuel-operated heaters in an area where flammable vapors, including gasoline or diesel fumes, are present, such as at filling stations and tank farms. Turn off a fuel-operated heater and allow it shut down completely before entering an area where flammable gases or liquids are present. Heaters continue to operate for up to three minutes after being turned off.

Failure to observe these precautions could cause an explosion or fire, resulting in serious property damage, and personal injury or death.

8

Cab Features

Cab Amenities	8.1
Mirrors and Windows	8.1

Cab Features

Cab Amenities

Cup Holders

There are two cup holders molded into the lower part of the auxiliary dash panel, one on either side of the climate control panel.

Cab Storage

There are storage bins in the dash and the overhead console.

Vehicles without an overhead console have two storage bins located above the windshield.

Some vehicles equipped with an overhead console may have a storage bin located in the overhead console. Those that don't have a storage bin in the overhead console will have a CB radio in its place.

On vehicles with individual driver's and passenger's seats, a center storage console can be installed between the seats.

The center storage console has a table top that can be lifted to deploy a writing surface. See [Fig. 8.1](#).

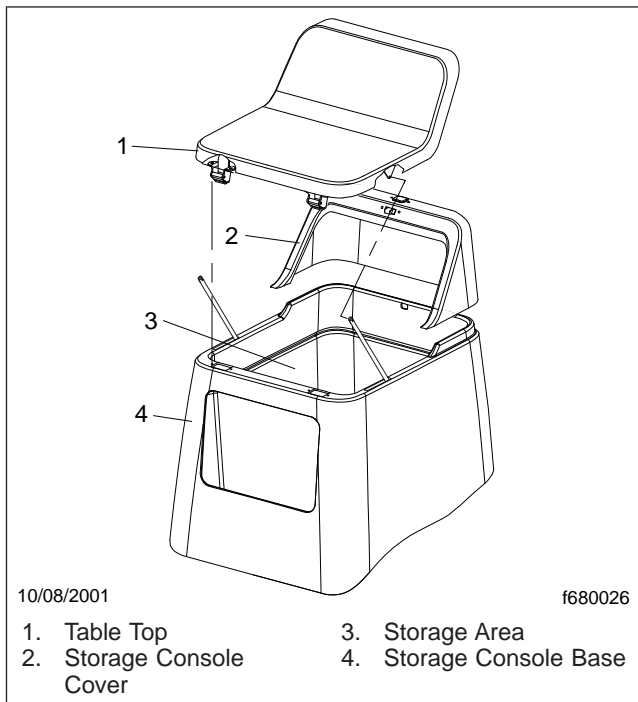

Fig. 8.1, Center Storage Console (with writing surface)

The center storage console may also be equipped with an optional printer top with a paper slot in it. See [Fig. 8.2](#).

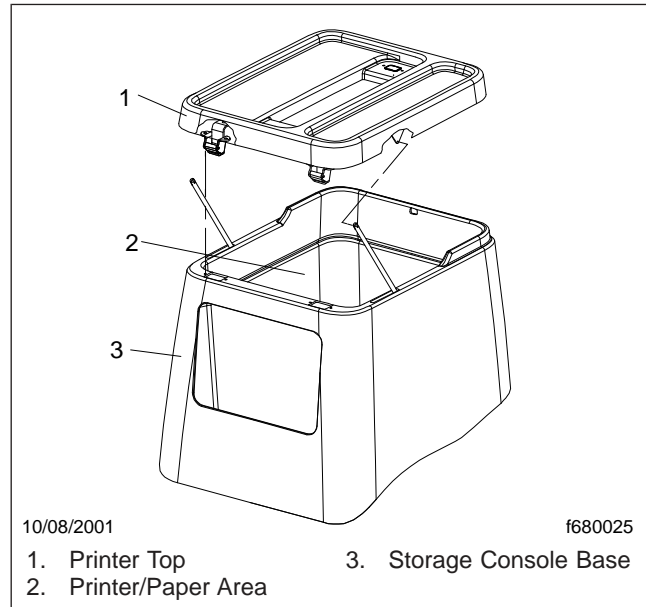

Fig. 8.2, Center Storage Console (printer option)

Mirrors and Windows

Mirrors

The standard outside mirrors are mounted on the door frame. There is a primary rear view mirror and a convex mirror.

Mirror Heat Switch, Optional

One or both outside door mirrors can be heated to keep them clear of fog, frost, and ice.

To heat the mirrors, press the upper part of the mirror heat switch (MIRR HEAT) on the dash. See [Fig. 8.3](#). When the mirror heat switch is on, an amber indicator light illuminates inside the switch.

Power Mirrors, Optional

The main outside mirrors, if heated, can be equipped with an electrical remote control located on the driver's door. See [Fig. 8.4](#).

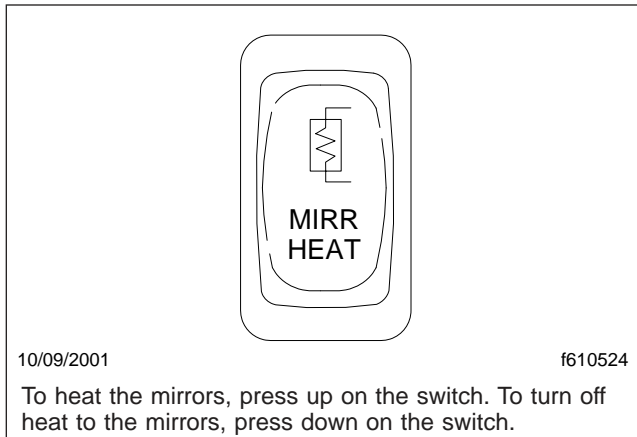

Fig. 8.3, Mirror Heat Switch

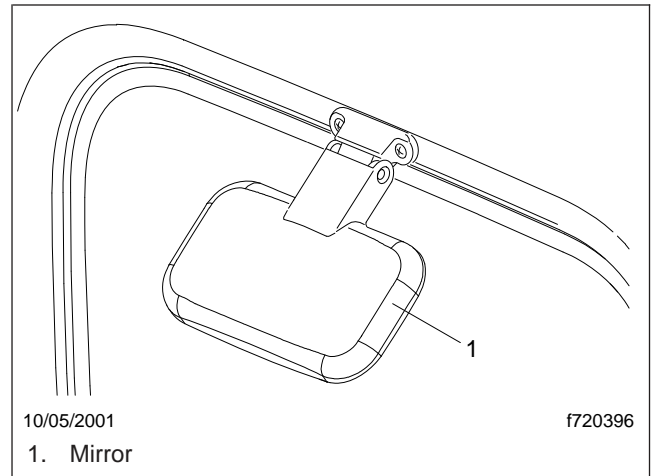

Fig. 8.5, Down View Mirror (optional)

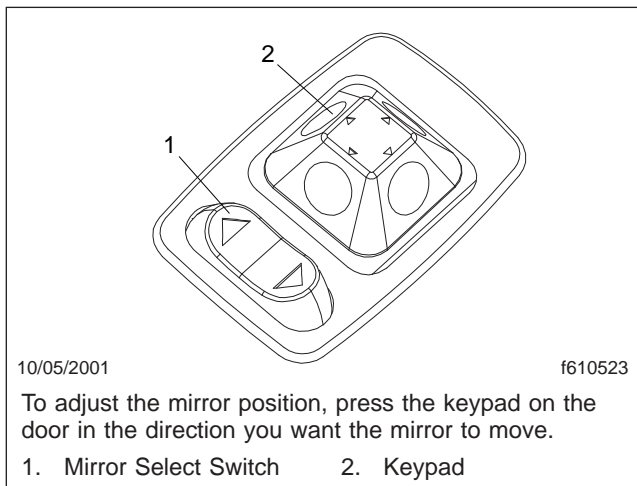

Fig. 8.4, Power Mirror Switch Pad

To select the mirrors on the left-hand side, press the left side of the mirror select switch. To select the mirrors on the right-hand side, press the right side of the mirror select switch.

The keypad has four arrow keys, pointing up, down, left, and right. To adjust mirror position, press the keypad in the direction you want the mirror to move.

Down View Mirror, Optional

A down view mirror can be installed on the top of the passenger door frame to allow the driver a view of the area adjacent to the right side of the cab. See [Fig. 8.5](#).

Windows

Standard windows operate mechanically using a hand crank.

Power windows are optional, and can be installed on one side or both sides. One power window switch will be installed on the dash for each window. See [Fig. 8.6](#). To raise the window, press up on the switch. To lower the window, press down on the switch. Releasing the switch will cause the window to stop.

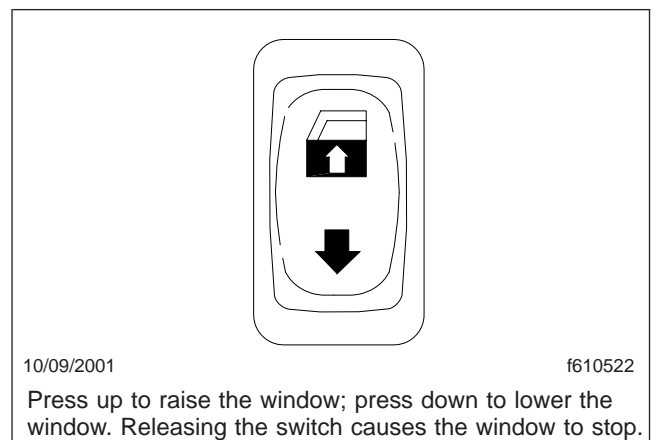

Fig. 8.6, Power Window Switch

Standard vent (wing) windows do not open. Operating vent windows are optional. To open the operating vent window, turn the latch on the window and push the window open. See [Fig. 8.7](#).

Cab Features

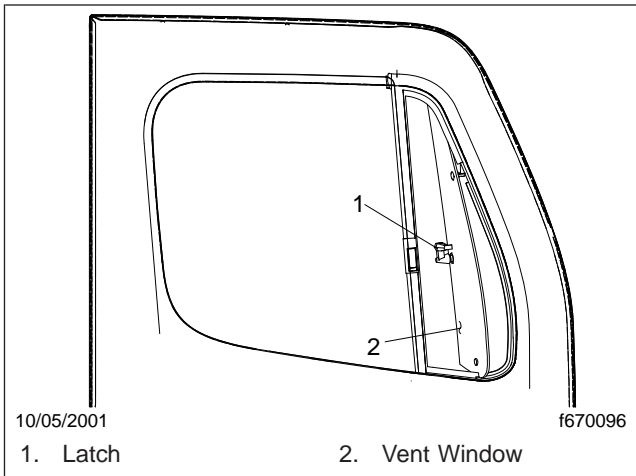

Fig. 8.7, Operating Vent Window (optional)

9

Engine Starting, Operation, and Shutdown

Engine Starting	9.1
Engine Operation	9.2
Engine Shutdown	9.3

Engine Starting, Operation, and Shutdown

Engine Starting

This engine chapter is to serve as a guide for best practices only. Each make and model engine may have operating characteristics that are unique to that particular engine, and will be documented in the engine manufacturer's literature. Always refer to specific instructions and recommendations from the engine manufacturer.

NOTE: Before starting the engine, read **Chapter 4** for detailed information on how to read the instruments and see **Chapter 5** for detailed information on how to operate the controls. Read the operating instructions in the manufacturer's engine operation manual before starting the engine.

WARNING

Never pour fuel or other flammable liquid into the air inlet opening in the air intake in an attempt to start the vehicle. This could result in a flash fire causing serious personal injury or property damage.

1. Before engine start-up, complete the engine pre-trip and post-trip inspections and maintenance procedures in **Chapter 20** and **Chapter 21**.
2. Set the parking brake.
3. For manual transmissions, place the transmission in neutral and fully depress the clutch pedal. Do not depress the accelerator pedal.

For automatic transmissions, put the transmission in neutral. Do not depress the accelerator pedal.

NOTICE

If the warning lights stay on, or do not come on momentarily after turning on the ignition, do not operate the engine. To do so may result in engine damage.

4. Turn the ignition switch to the ON position. See **Fig. 9.1**. Electronic gauges on the instrumentation control unit (ICU) will complete a full sweep of their dials, the warning and indicator lamps will illuminate, and the buzzer will sound for three seconds.

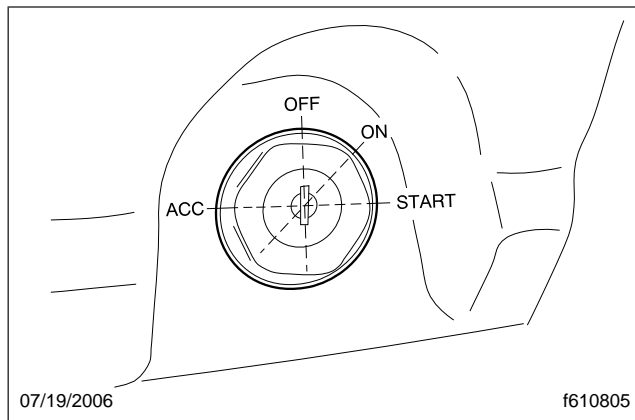

Fig. 9.1, Ignition Switch

During cold conditions, the WAIT TO START lamp may illuminate on vehicles with Cummins engines. Wait until the lamp goes out before turning the ignition key to START.

NOTE: The length of time the WAIT TO START lamp remains illuminated depends on the ambient temperature. The lower the ambient temperature, the longer the lamp will be illuminated.

NOTE: The engine electronics supply the correct amount of fuel for starting the engine. Accelerator pedal pressure is unnecessary, and could interfere with engine starting.

5. Turn the ignition key to the START position. Do not depress the accelerator pedal. Release the key the moment the engine starts.
6. Apply load gradually during the warm-up period.

NOTICE

Do not rev the engine if the oil pressure gauge indicates no oil pressure. Shut down the engine within approximately ten seconds to avoid engine damage.

7. Check the oil pressure gauge for any drop in lubricating oil pressure or mechanical malfunction in the lubricating oil system.

Cold-Weather Starting

See the engine manufacturer's operation manual for starting aids that are approved for specific engines.

Engine Starting, Operation, and Shutdown

Starting After Extended Shutdown

Before engine start-up, complete the engine pretrip and post-trip inspections and maintenance procedures in [Chapter 20](#) and [Chapter 21](#).

NOTICE

Failure to eliminate water-diluted lubricating oil may lead to serious engine damage at startup.

An engine in storage for an extended period of time (over winter, for example) may accumulate water in the oil pan through normal condensation of moisture on the internal surfaces of the engine. Oil diluted by water cannot provide adequate bearing protection at start-up. For this reason, change the engine oil and filters after extended storage.

Engine Operation

Safety and Environmental Considerations

All Freightliner diesel engines comply with the requirements of the Federal (U.S.) Clean Air Act. Once an engine is placed in service, the responsibility for meeting both state and local regulations is with the owner/operator.

NOTICE

It is extremely important that the following guidelines be followed for engines that comply with EPA10 or newer regulations, or damage may occur to the aftertreatment device, and the warranty may be compromised.

- **Use ultralow-sulfur diesel with 15 ppm sulfur content or less.**
- **Do not use fuel blended with used engine lube oil or kerosene.**
- **Use only engine lube oil with a sulfated ash level less than 1.0 wt%; currently referred to as CJ-4 oil.**

Adequate maintenance of the engine and the diesel particulate filter (DPF) are the responsibility of the owner/operator, and are essential to keep the emission levels low. Good operating practices, regular maintenance, and correct adjustments are factors that will help keep emissions within the regulations.

The driver should be familiar with the vehicle warning system in order to bring the vehicle to a safe stop if the engine malfunctions. If the driver doesn't understand how the warning system works, an engine shutdown could occur, causing a safety hazard. See [Chapter 10](#) for more information.

Engine Break-In

Each engine must pass a full-load operating test on a dynamometer before shipment, thereby eliminating the need for a break-in. Before running the engine for the first time, follow the instructions in the engine manufacturer's operation manual specific to your engine.

Normal Operation

WARNING

Do not operate the engine in an area where flammable vapors such as gasoline or diesel fumes are present. Shut off the engine when in an area where flammable liquids or gases are being handled. Failure to observe these precautions could result in serious injury or death.

Every engine has an operating range in which it performs most efficiently. The operating range extends from maximum torque rpm at the low end, to engine rated speed at the high end. Most engines deliver best fuel economy when operated in the low- and mid-speed segments of the efficiency range and produce maximum horsepower at rated speed, which is also the recommended maximum speed of the engine. For further engine-specific information, refer to the engine manufacturer's operation manual.

Prolonged idling of engines is not recommended, and is illegal in some states. Idling produces sulfuric acid, that is absorbed by the lubricating oil, and eats into bearings, rings, valve stems, and engine surfaces. If you must idle the engine for cab heat or cooling, use the high idle function of the cruise control switches. An idle speed of 900 rpm should be enough to provide cab heat in above freezing ambient temperatures.

If the engine is programmed with the idle shutdown timer, ninety seconds before the preset shutdown time, the CHECK ENGINE light will begin to flash at a rapid rate. If the position of the clutch pedal or service brake changes during this final ninety seconds the idle shutdown timer will be disabled until reset.

Engine Starting, Operation, and Shutdown

Cold-Weather Operation

Satisfactory performance of a diesel engine operating in low ambient temperatures requires modification of the engine, surrounding equipment, operating practices, and maintenance procedures. The lower the temperature, the greater the amount of modification required. For service products approved for use in cold weather for your engine, see the engine manufacturer's engine operation manual, supplied in the vehicle documentation package.

If satisfactory engine temperature is not maintained, maintenance costs will increase due to greater engine wear. If the engine coolant temperature becomes too low, raw fuel will wash the lubricating oil off the cylinder walls and dilute the crankcase oil, causing all moving parts of the engine to suffer from poor lubrication.

If the engine is in good mechanical condition and the precautions necessary for cold-weather operation are taken, ordinary cold weather will not cause difficulty in starting or loss of efficiency.

The following points are important to observe when operating in cold weather:

- Check for cracks in the batteries, for corrosion of the terminals, and for tightness of the cable clamps at the terminals.
- Charge the batteries to full capacity. Replace any battery that is damaged.
- If equipped, turn off the load disconnect switch after the engine is shut down, to prevent battery discharge.
- Have the alternator output checked at an authorized service provider.
- Check the condition and tension of the drive belts.
- Refer to the engine manufacturer's engine operation manual for recommended heaters, low-viscosity lubricating oils, wintergrade fuels, and approved coolants.

A winterfront may be used to improve cab heating while idling. If a winterfront is used, at least 25% of the grille opening should remain open in sectioned stripes that run perpendicular to the charge air cooler tube-flow direction. This assures even cooling across each tube, and reduces header to tube stress, and possible failure. Winterfronts should only be used

when the ambient temperature remains below 10°F (-12°C).

Engine Shutdown

1. With the vehicle stopped, apply the parking brake and place the transmission in neutral.

NOTICE

Idle the engine one to two minutes before shutting it down. After hard operation, shutting down the engine without idling may cause damage to the turbocharger.

2. Allow the engine to idle one to two minutes before shutting it down. This allows the lubricating oil and the coolant to carry heat away from the combustion chambers, bearings, shafts, and seals. The extreme heat may cause bearings to seize or oil seals to leak.

IMPORTANT: Bearings and seals in the turbocharger are subjected to the high heat of combustion exhaust gases. While the engine is running, this heat is carried away by oil circulation, but if the engine is stopped suddenly, the turbocharger temperature may rise as much as 115°F (46°C).

NOTICE

Except in an emergency, do not shut down the engine when the coolant temperature is above 194°F (90°C). To do so could damage the engine.

3. Turn off the ignition switch and shut down the engine.

10

Optional Engine Systems

Engine Protection—Warning and Shutdown	10.1
Engine Idle Limiting	10.2
Cruise Control	10.2
Auxiliary Braking Applications	10.3
Power Takeoff (PTO) Governor	10.6

Optional Engine Systems

Engine Protection—Warning and Shutdown

The driver should be familiar with the vehicle warning system in order to bring the vehicle to a safe stop if the engine malfunctions. If the driver doesn't understand how the warning system works, an engine shutdown could occur.

The engine will begin a warning and shutdown process if the engine coolant temperature, coolant level, engine oil pressure, or exhaust aftertreatment system (ATS) reach preset levels. On some engines, the engine will also begin the warning and shutdown process when the engine oil temperature or the intake air temperature reach preset levels. Detroit Diesel engines will also begin the warning and shutdown process if water is detected in the fuel.

See the engine manufacturer's operation manual for specific details for your vehicle.

See **Chapter 11** in this manual for the warning and shutdown modes associated with the ATS.

Electronic engine protection is programmable as an option, and can be specified as the following: DERATE and SHUTDOWN mode (factory default), WARNING mode, or OFF mode.

WARNING

When the red STOP engine or engine protection light illuminates, most engines are programmed to shut down automatically within 30 seconds. The driver must immediately move the vehicle to a safe location at the side of the road to prevent causing a hazardous situation that could cause bodily injury, property damage, or severe damage to the engine.

In the DERATE and SHUTDOWN mode, the red STOP engine lamp will illuminate when the problem is serious enough to reduce power or speed. See **Fig. 10.1**. Engine power will ramp down, then the engine will shut down if the problem continues. The driver has 30 seconds or 60 seconds (depending on the critical fault type) after the STOP engine lamp illuminates to move the vehicle safely off the road. If the vehicle cannot be moved to a safe location within that time, the engine can be restarted by turning the ignition switch to the OFF position for at least five seconds, then back ON. Repeat this action until the vehicle is safely off the road.

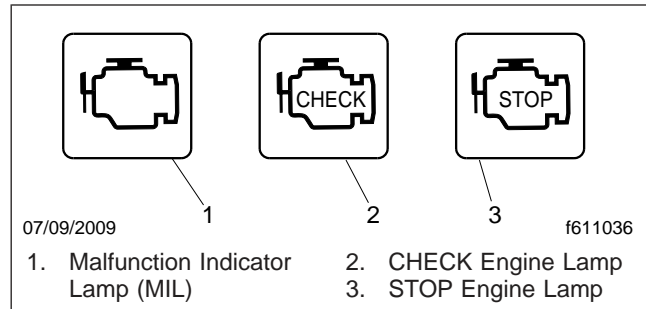

Fig. 10.1, Engine Warning Lights

Some vehicles may have a shutdown-override switch, which may be used to momentarily override the shutdown sequence. See **Fig. 10.2**. This switch resets the shutdown timer, restoring power to the level before the derate for another 30 or 60 seconds (depending on the critical fault type). The switch must be pressed again after 5 seconds to obtain a subsequent override. It can be used to move the vehicle to a safe stopping area. Do not operate the vehicle further until the problem has been corrected.

If the engine protection parameters are set to WARNING mode, the amber CHECK engine lamp will flash and a buzzer will sound. The engine electronics log the event for diagnostic purposes. The CHECK engine lamp will go out if the problem stops.

If the engine protection parameters are set to OFF mode, the individual sensor indicator lamps will illuminate if a problem exists, but no shutdown action will be started and the event will not be recorded.



Fig. 10.2, Shutdown Override Switch

Engine Idle Limiting

Idle Shutdown Timer

This feature is an optional 1- to 100-minute idle shutdown system. Its purpose is to conserve fuel by eliminating excessive idling and allowing a turbo-charger cool-down period. Idle shutdown timing and parameters are programmable. See the engine manufacturer's operation manual for specific details for your vehicle.

California Engine Idle Limiting

In order to meet the California Air Resources Board (CARB) engine idle limiting standard, an engine idle shutdown feature has been included in engine control strategy. When the CARB engine idle limiting feature is enabled, the engine will **generally** shut down after five minutes of continuous idling when the transmission is in neutral or park and the parking brake is set. It will also shut down after fifteen minutes when the transmission is in neutral or park, with the parking brake off. See the engine manufacturer's operation manual for specific details for your vehicle.

After an automatic shutdown, the engine may be restarted and operated normally.

Activating or momentarily changing the position of the brake pedal, clutch pedal, accelerator pedal, stop-engine override switch, or parking brake during the final thirty seconds will cause the shutdown timer to reset, and will prevent the engine from shutting down.

The automatic shutdown feature is required on all California-certified engines (with the exception of engines used in specific vehicle types that the state of California has determined to be exempt from the requirement). Owners that wish to have the shutdown feature disabled on vehicles operating in California should consult with California authorities to determine if their vehicle qualifies for the exemption.

The automatic shutdown feature is generally disabled on engines certified by the U.S. EPA for use outside of California.

Cruise Control

WARNING

Do not use the cruise control system when driving conditions do not permit maintaining a constant speed, such as in heavy traffic or on roads that are winding, icy, snow-covered, slippery, or roads with a loose driving surface. Failure to follow this precaution could cause a collision or loss of vehicle control, possibly resulting in personal injury or property damage.

NOTICE

When the cruise control is engaged, do not attempt to shift gears without using the clutch pedal. Failure to follow this precaution will result in a temporarily uncontrolled increase in engine speed. Transmission damage and gear stripping could result.

Cruise control is activated by two dash-mounted switches ([Fig. 10.3](#)).

- On/Off Switch—this two-position rocker is labeled SPD CNTL on the lower half of the switch. When cruise control is on, an amber light illuminates the top part of the switch.
- Set/Resume Switch—this three-position paddle switch is labeled RES/ACC above the paddle and SET/CST below the paddle.

1. To cruise at a particular speed:
 - 1.1 Press the upper half of the On/Off switch.
 - 1.2 Hold the accelerator pedal down until the speedometer reaches the desired speed.
 - 1.3 Momentarily lower the paddle of the Set/Resume switch to SET/CST.
2. To disengage the cruise control:
 - 2.1 Depress the brake pedal (on an automatic or manual transmission) *or*
Depress the clutch pedal (on a manual transmission only).
 - 2.2 Press the lower half of the On/Off switch.
3. To resume a preselected cruise speed:
 - 3.1 Ensure the On/Off switch is on.

Optional Engine Systems

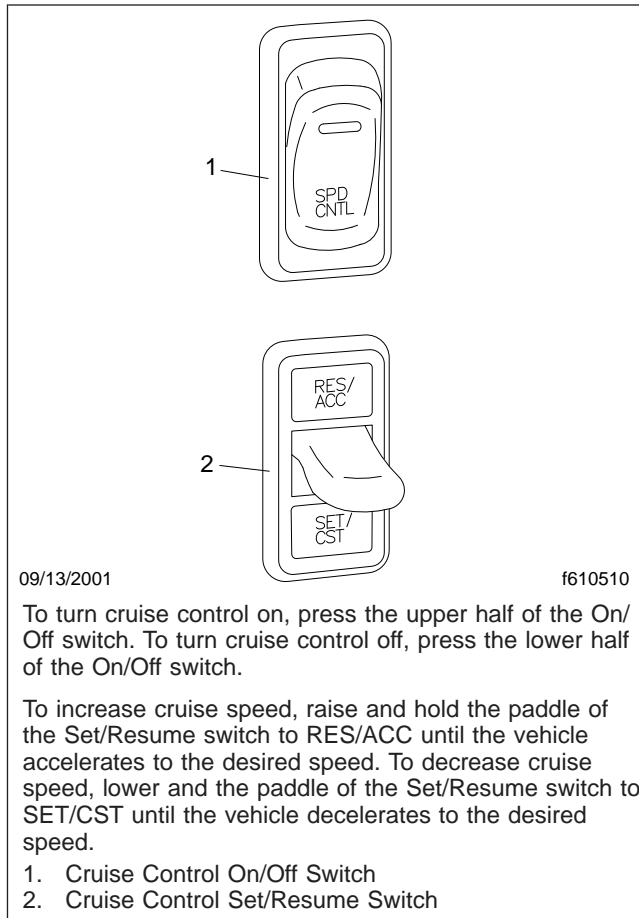

Fig. 10.3, Cruise Control Switches

- 3.2 Momentarily raise the paddle of the Set/Resume switch to RES/ACC. Cruise will return to the last speed selected.

NOTE: When the vehicle speed drops below the minimum cruise control speed, cruise control will disengage. To resume to the pre-selected cruise speed, increase vehicle speed to above minimum cruise control speed and momentarily raise the paddled of the Set/Resume switch to RES/ACC.

NOTE: The speed memory is lost whenever the ignition is turned off or the cruise control switch is toggled to Off.

4. To increase cruise speed, raise and hold the paddle of the Set/Resume switch to RES/ACC

until the vehicle accelerates to the desired speed.

5. To decrease cruise speed, lower and the paddle of the Set/Resume switch to SET/CST until the vehicle decelerates to the desired speed.

Auxiliary Braking Applications Engine Brake

Each engine manufacturer uses a specific engine brake for their engine. Regardless of the manufacturer, the engine brake is operated with the principles outlined in this chapter. Refer to the engine manufacturer's operation manual for details of their particular engine brake product.

WARNING

To avoid injury from loss of vehicle control, do not activate the engine brake system under the following conditions:

- on wet or slippery pavement, unless the vehicle is equipped with antilock braking system (ABS) and you have had prior experience driving under these conditions;
- when driving without a trailer or pulling an empty trailer;
- if the tractor drive wheels begin to lock, or there is fishtail motion after the engine brake is activated.

Whenever vehicle braking is required on good road conditions, the engine brake may be used in conjunction with the service brakes. There is no time limit for operation of the engine brake. However, an engine brake does not provide the precise control of, and is not a substitute for, service brakes.

WARNING

Usage of the engine brake as the primary braking system can cause unpredictable stopping distances, that could result in personal injury or property damage. Service brakes are the primary vehicle braking system.

Two dash-mounted switches control the engine brake:

- The On/Off switch (ENG BRK), is used to turn the engine brake on and off. See [Fig. 10.4](#). When the engine brake is on, an amber light will illuminate behind the switch.
- The engine brake intensity switch (HI/MED/LO or, in some cases, HI/LO) controls the amount of engine braking. When the panel lights are on, the ENG BRK legend is backlit in green.

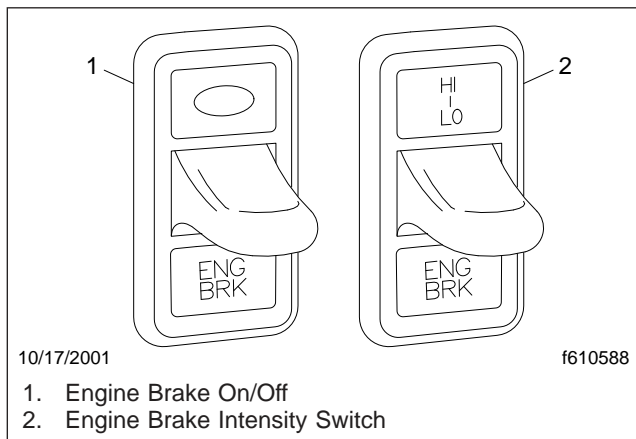

Fig. 10.4, Engine Brake Switches

Since the engine brake is most effective at rated engine speed, gear selection is very important. Gearing down the vehicle within the limits of the rated engine speed makes the engine brake more effective. Recommended engine braking speed is above 1800 rpm and below the rated speed.

WARNING

The engine brake must be disengaged when shifting gears using the clutch pedal. If the engine brake is engaged when the transmission is in neutral, the braking power of the engine brake can stall the engine, which could result in loss of vehicle control, possibly causing personal injury and property damage.

"Control speed" is the speed at which the engine brake performs 100 percent of the required downhill braking, resulting in a constant speed of descent. The control speed varies, depending on vehicle weight and the downhill grade.

For faster descent, select a higher gear than that used for control speed. Service brakes must then be used intermittently to prevent engine overspeed and to maintain desired vehicle speed.

For slower descent, select a lower gear, being careful not to overspeed the engine. Occasional deactivation of the engine brake may be necessary to maintain the designated road speed under these conditions.

If the engine is equipped with both cruise control and an engine brake, the engine brake can operate automatically while in cruise control mode. If the cruise control/engine brake function is turned on in the DDEC VI system programming, the engine brake will come on low when the set road speed increases a few miles-per-hour (kilometers-per-hour) above the cruise set speed. The maximum amount of braking is selected with the dash switches. When the vehicle returns to the set cruise speed, the engine brake will turn off.

The engine brake will only operate when the accelerator pedal is fully released. Depressing the clutch will also prevent the engine brake from operating.

Vehicles equipped with ABS have the ability to turn the engine brake off if wheel slip is detected. The engine brake will automatically turn back on once wheel slip is no longer detected.

The DDEC VI system will deactivate the engine brake when the engine speed falls below 1000 rpm or when the vehicle slows down to a preset speed, depending on DDEC programming. This prevents stalling the engine.

Engine Brake Operation

Depending on the brake type, the engine brake may be disabled when engine temperature falls below a set level.

NOTICE

Do not allow the engine to exceed 2500 rpm. Serious engine damage could result.

To activate the engine brake after the engine is warmed up and the vehicle is in motion:

1. Remove your feet from both the clutch and throttle pedals.
2. Press the On/Off switch to toggle the engine brake on. See [Fig. 10.4](#). The engine brake will engage at the rate last set on the brake intensity switch.
3. Move the intensity switch to the desired intensity.

Optional Engine Systems

On vehicles with a HI/MED/LO intensity switch, LO will provide 1/3 of the full braking capacity of the engine, MED will provide 2/3 of the full braking capacity, and HI will provide maximum engine braking. On vehicles with a HI/LO intensity switch, LO will provide 1/2 of the full braking capacity of the engine; HI will provide maximum engine braking.

4. Use the intensity switch set at the LO position when driving on flat, open stretches of road. If the service brakes are still required to slow down on a grade, switch to a higher setting on the dash switch until there is no need for the service brakes. Grade descent speed should be such that the service brakes are used infrequently and remain cool, thus retaining their effectiveness.
5. For maximum retarding, maintain the top governed speed of the engine through the appropriate selection of gears. When shifting gears, the engine brake will disengage when the clutch pedal is depressed, then engage when the clutch pedal is released.
6. To cancel the engine brake application, toggle the On/Off to off.

Exhaust Brake, Cummins Engines

An exhaust brake is an optional auxiliary braking system that assists but does not replace the service brake system. The exhaust brake may be used in conjunction with the service brakes in off-highway and mountain driving as well as in traffic or high-speed highway driving. Exhaust brakes are not intended for use as the primary braking system during vehicle operation.

The exhaust brake is controlled by a dash-mounted rocker switch. See [Fig. 10.5](#) or [Fig. 10.6](#).

To turn the exhaust brake on, press the upper part of the rocker. When the exhaust brake is on, an amber light illuminates behind the switch. When the panel lights are on, the EXHST BRK legend is backlit in green.

The exhaust brake turns itself off automatically. In addition, depressing the accelerator or clutch pedal deactivates the exhaust brake. The ABS, when active, also deactivates the exhaust brake.

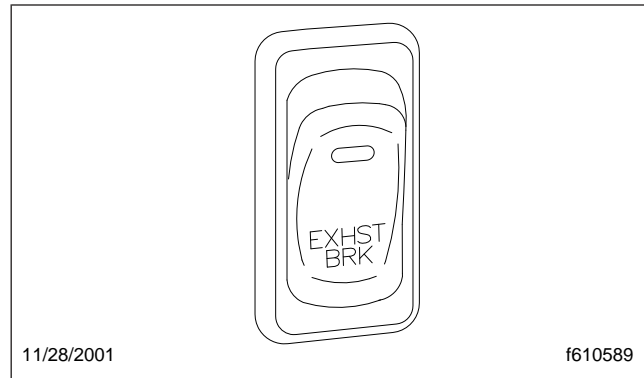

Fig. 10.5, Exhaust Brake Switch

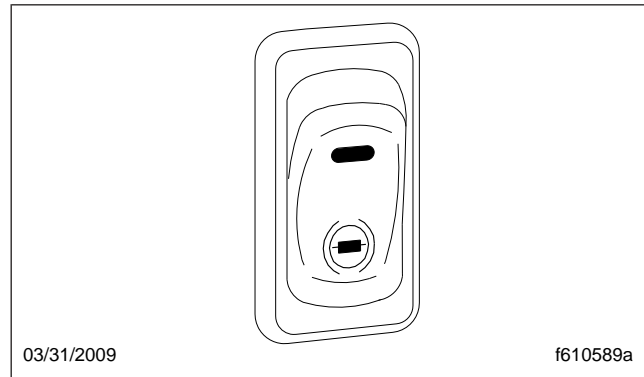

Fig. 10.6, Exhaust Brake Switch

Exhaust Brake Operation

WARNING

Do not use the exhaust brake when driving on slippery or low-traction road surfaces. Failure to follow this precaution could result in a loss of vehicle control and possible personal injury or property damage.

1. Before starting the engine, make sure that the exhaust brake is off. Wait until the engine has reached normal operating temperature to turn on the exhaust brake.
2. When approaching a downhill grade, press the upper half of the exhaust brake switch to turn the exhaust brake on. When the exhaust brake is on, an amber light will illuminate behind the switch.
3. Remove your feet from the accelerator and clutch pedals.

NOTICE

Do not allow the engine to exceed its governed speed, or serious engine damage could result.

NOTE: The exhaust brake is only active when engine speed is between 1100 and 2700 rpm.

4. While going down the grade, use a low enough gear to safely descend with a minimum application of the service brakes. As a general guideline, use the same gear as you would to ascend the hill.

The following conditions should exist if the brake is operating properly:

- A slight change in the sound of the engine may be noticed when the exhaust brake is applied.
 - Exhaust smoke should appear normal.
 - Engine temperature should remain in the normal operating range.
 - Road speed usually decreases when the exhaust brake is applied during a descent. When the vehicle is carrying a heavy load or the grade is extremely steep, you may need to apply the service brakes occasionally.
 - Do not expect a retarding effect similar to sudden hard application of the service brakes. The exhaust brake retards the vehicle with a smooth braking effect.
 - During a descent, the tachometer usually shows a drop in rpm, depending on the grade and the vehicle load.
 - Depending on the grade and vehicle load, you may or may not feel the retarding force acting against your body when the brake is applied. The retarding force of the brake may not always be noticed, but it is actually preventing the vehicle from going much faster.
5. Apply the service brakes to reduce the engine rpm or make a slower descent by using a lower gear.
 6. Make sure the exhaust brake is turned off before shutting down the engine.

Power Takeoff (PTO) Governor

Engine power takeoffs (PTO) are devices used to tap into engine power to run auxiliary devices, such as hydraulic pumps that power additional equipment. The following instructions are general guidelines for operating a PTO.

1. Set the parking brake and put the transmission in neutral.
2. Press the dash-mounted PTO switch. Release the switch when the amber light behind the switch begins to blink.

When the light is steadily illuminated, the PTO is engaged and ready to operate. In stationary mode, the vehicle must remain in neutral with the parking brake set.

3. To activate the mobile mode, shift from neutral to reverse, 1st, or 2nd gear. The clutch will open and the PTO will disengage for a moment.
4. Touch the throttle pedal to close the clutch and engage the PTO in mobile mode. The PTO may be operated with the transmission in reverse, neutral, 1st, or 2nd gears only.

NOTE: Do not attempt to change gears while the vehicle is moving. The transmission will ignore the request.

5. To end the mobile mode, bring the vehicle to a stop. The clutch will open and shut down power to the PTO.
6. To resume stationary mode, shift to neutral. The PTO will engage.
7. To end stationary mode, press the dash switch. When the light in the switch goes out, power to the PTO is shut off.

11

Emissions and Fuel Efficiency

Greenhouse Gas Emissions and Fuel Consumption Standards	11.1
EPA-Regulated Emissions Aftertreatment System	11.1
Diesel Exhaust Fluid and Tank	11.3

Emissions and Fuel Efficiency

Greenhouse Gas Emissions and Fuel Consumption Standards

Vehicles and/or engines manufactured after December 31, 2006 and domiciled in the U.S. or Canada are required to meet all EPA and NHTSA regulations effective as of the vehicle build date. Engines manufactured between January 1, 2010 and December 31, 2012 meet EPA10 requirements. Engines manufactured from January 1, 2013 meet NHTSA and EPA 2014 fuel efficiency and greenhouse gas emission standards (GHG14) requirements.

Model year 2013 and later vehicles meet additional requirements as specified by GHG14 requirements. These vehicles are equipped with components that increase fuel efficiency and reduce GHG emissions. Components may include, but are not limited to, low-rolling resistance tires; aerodynamic devices such as hood, cab/sleeper extenders, and fuel tank fairings; vehicle speed limiter; and idle shutdown timer. If replacement of any drag-reducing component is required, the replacement component must meet or exceed the drag reduction performance of the originally installed component in order to maintain compliance with GHG14 requirements.

EPA-Regulated Emissions Aftertreatment System

NOTICE

It is extremely important that the guidelines below are followed for engines that comply with EPA10 and newer regulations, or damage may occur to the aftertreatment device, and the warranty may be compromised.

- Use ultralow-sulfur diesel with 15 ppm sulfur content or less.
- Do not use fuel blended with used engine lube oil or kerosene.
- Use only engine lube oil with a sulfated ash level less than 1.0 wt%; currently referred to as CJ-4 oil.

IMPORTANT: Using non-specification fuels or oils can lead to shortened diesel particulate filter (DPF) cleaning or replacement intervals. For

example, using CJ-4+ oil with 1.3% sulfated ash (30% more ash content) may result in the need for DPF cleaning or replacement 20 to 30% sooner than would normally be required.

IMPORTANT: See the engine manufacturer's operation manual for complete details and operation of the ATS.

The EPA mandates that all engines built after December 31, 2009 must reduce the level of emissions exhausted by the engine to the following levels:

- Nitrogen Oxides (NOx) – 0.2 g/bhp-hr
- Particulate Matter (PM) – .01 g/bhp-hr

To meet EPA guidelines, engines that are compliant with EPA10 and newer regulations use technology known as selective catalytic reduction (SCR) in the exhaust aftertreatment system (ATS). The ATS includes an aftertreatment device (ATD), with the addition of SCR to reduce NOx downstream of the engine. The SCR process requires the introduction of diesel exhaust fluid (DEF) into the exhaust stream.

After exhaust gases leave the engine, they flow into the ATS. First they flow into a two-part ATD, comprised of a diesel oxidation catalyst (DOC) and a diesel particulate filter (DPF). The DPF traps soot particles, then exhaust heat converts the soot to ash, in a process called regeneration (regen). After exhaust gases leave the DPF, a controlled quantity of diesel exhaust fluid (DEF) is injected into the exhaust stream. In the presence of heat, DEF is converted to ammonia gas, which reacts with NOx in the selective catalyst chamber to yield nitrogen and water vapor, which exit through the tailpipe.

Regeneration

The harder an engine works, the better it disposes of soot. If the exhaust temperature is high enough, a process called **passive regeneration** (regen) occurs as the vehicle is driven normally. However, if the engine isn't running hot enough, the electronic controls may initiate an **active regen**, whereby extra fuel is injected into the exhaust stream to superheat and reduce the soot trapped in the DPF to ash. Active regen happens only when the vehicle is moving above a certain speed, determined by the engine manufacturer. See your engine operation manual for complete details. Both active and passive regen happen automatically, without driver input.

WARNING

Active regeneration can occur automatically anytime the vehicle is moving. The exhaust gas temperature could reach 1500°F (800°C), which is hot enough to cause a fire, heat damage to objects or materials, or personal injury to persons near the exhaust outlet. The exhaust temperature can remain high even after the vehicle has stopped. When stopping the vehicle shortly after an automatic regen, ensure the exhaust outlets are directed away from structures, trees, vegetation, flammable materials, and anything else that may be damaged or injured by exposure to high heat.

See *Regen Switches*, below, for instructions on preventing automatic regen if necessary.

When operating conditions do not allow for ATD filter cleaning by active or passive regen, the vehicle may require a driver-activated **parked regen**. When this occurs, the DPF lamp illuminates, indicating that a regen is required. The driver must either bring the vehicle up to highway speed to increase the load (thus starting an active regen), or park the vehicle and initiate a parked regen. See *Regen Switches*, below, for instructions on initiating a parked regen.

Regen Switches

The regen request switch, located on the dash, is used to initiate a parked regen. See [Fig. 11.1](#). The function of the switch varies by the engine make and model in the vehicle. See the engine operation manual for switch operation details.

Some vehicles may be equipped with a regen request/inhibit switch. See [Fig. 11.2](#). To stop a regen in progress or prevent the start of a regen, press the lower half of the switch. Regen is then delayed until the switch is no longer active.

NOTE: The regen switch can initiate a parked regen only when the DPF lamp is illuminated.

WARNING

During parked regen, exhaust temperatures are very high and could cause a fire, heat damage to objects or materials, or personal injury to persons near the exhaust outlet.

Before initiating a parked regeneration, make certain the exhaust outlets are directed away from

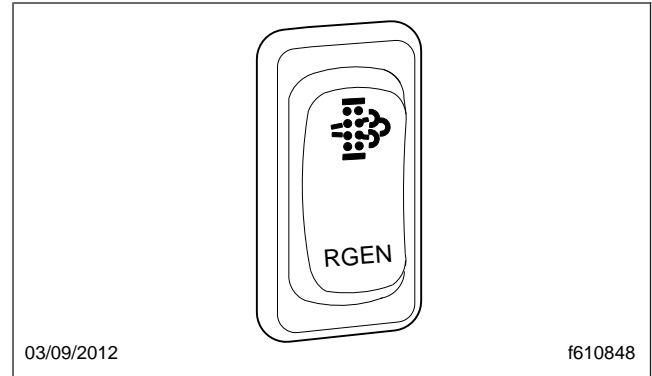

Fig. 11.1, Regen Request Switch

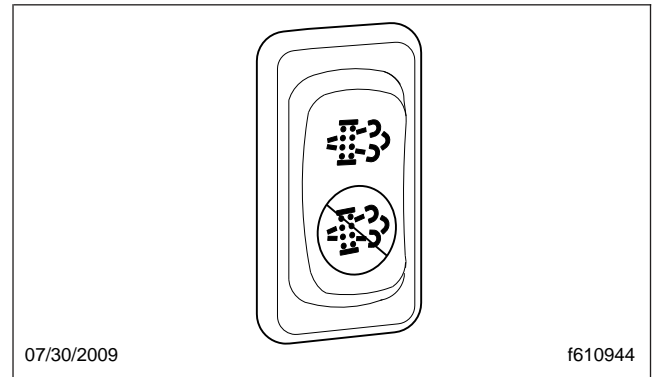

Fig. 11.2, Regen Request/Inhibit Switch

structures, trees, vegetation, flammable materials, and anything else that may be damaged or injured by prolonged exposure to high heat.

To initiate a parked regen, perform the following steps.

1. Park the vehicle away from all flammable materials, put the transmission in neutral, and set the parking brake.
2. Start and warm the engine until the coolant temperature is at least 150°F (66°C).
3. Lift the regen request switch guard and press and hold the yellow button for five seconds. As the regen process is initiated, engine rpm increases and the HEST lamp illuminates to indicate extremely high exhaust temperatures.

IMPORTANT: The driver must remain with the vehicle during the entire regen cycle.

4. The regen cycle will finish after 20 to 60 minutes, at which time engine idle speed drops to normal

Emissions and Fuel Efficiency

and the vehicle can be driven normally. The HEST lamp is extinguished when vehicle speed exceeds 5 mph (8 km/h) or the system has cooled to normal operating temperature.

5. To stop a parked regen at any time during the process:
 - depress the clutch pedal, brake pedal, or accelerator pedal;
 - press and hold the regen inhibit switch until idle returns to normal;
 - shut down the engine.

ATS Warning Lamps

There are three warning lamps that alert the driver of high exhaust temperature, the need to perform a parked regen or service the DPF, or of an engine fault that affects emissions. A decal attached to the driver's sun visor explains the ATS warning lamps. [Fig. 11.3](#).

See [Fig. 11.4](#) for an explanation of the ATS warnings, and actions required to avoid engine protection sequences.

Malfunction Indicator Lamp (MIL)

A steadily illuminated yellow malfunction indicator lamp (MIL) indicates an engine fault that affects emissions. See [Fig. 11.5](#).

DPF Status Lamp

When soot accumulates in the DPF and the DPF status lamp illuminates, see [Fig. 11.6](#), perform a parked regen or bring the vehicle up to highway speed to increase the load (thus starting an active regen).

If the DPF status lamp blinks while the CHECK engine lamp is illuminated, initiate a parked regen immediately in order to prevent an engine derate.

If the red STOP engine lamp illuminates with the blinking DPF lamp and the CHECK engine lamp, begin a parked regen in order to prevent an engine shutdown. Park the vehicle and perform a parked regen.

High Exhaust System Temperature (HEST) Lamp

Slow (10-second) flashing of the high exhaust system temperature (HEST) lamp indicates that a

parked regen is in progress, and the engine's high idle speed is being controlled by the engine software, not the vehicle driver.

Steady illumination of the HEST lamp alerts the driver of high exhaust temperature during the regen process if the vehicle speed is below 5 mph (8 km/h), or during a parked regen. See [Fig. 11.7](#).

DPF Maintenance

Eventually ash will accumulate in the DPF and the filter will require servicing. DPF servicing must be performed by an authorized technician, following the engine manufacturer's instructions. A record must be maintained for warranty purposes, that includes:

- date of cleaning or replacement;
- vehicle mileage;
- particulate filter part number and serial number.

Diesel Exhaust Fluid and Tank

Diesel Exhaust Fluid

Diesel exhaust fluid (DEF) is used in the ATS to lower NOx in the exhaust stream. DEF is colorless and close to odorless (it may have a slightly pungent odor similar to ammonia). It is nontoxic, nonflammable, and biodegradable. It is mildly corrosive to aluminum, but does not affect the strength or structure of the aluminum.

White crystals may be noticeable around components that come into contact with DEF. The crystals are easily removed with water.

DEF consumption varies depending on ambient conditions and vehicle application.

Freezing Conditions

DEF freezes to slush at around 12°F (-11°C). It is not damaged or destroyed if frozen, and is fully usable when thawed. The DEF in the tank is allowed to freeze while a vehicle is non-operational. At start-up, normal operation of the vehicle is not inhibited if the DEF is frozen; an immersion heater with engine coolant flowing through it warms the DEF once the engine is running, allowing the SCR system to operate.

Pre-2013 DEF supply lines are electrically-heated and are purged when the engine is shut down; complete purging of the DEF lines requires approximately five minutes after the engine is shut down.

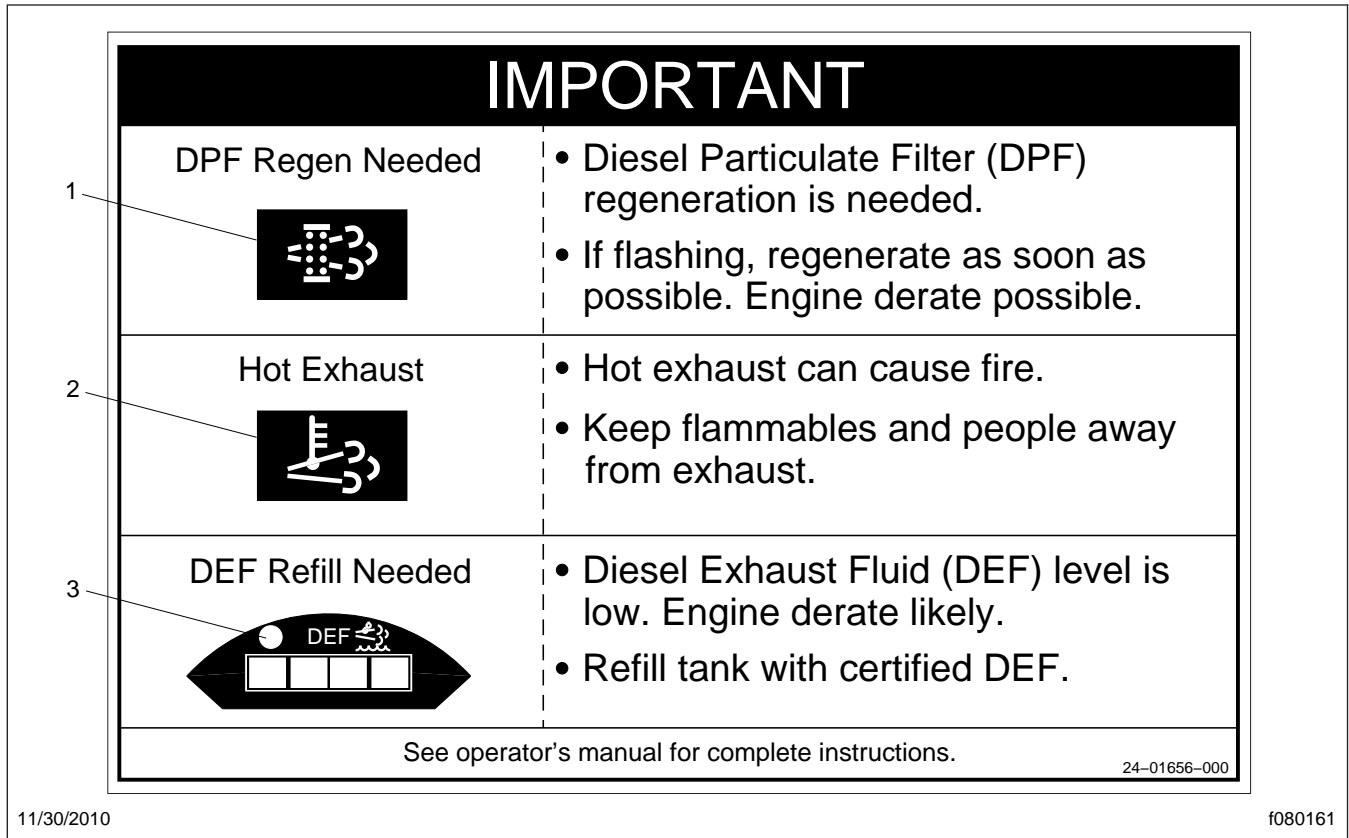

Fig. 11.3, Warning Lamp Decal, Sun Visor

DEF supply lines with engine model year 2013 and newer are designed to survive freezing conditions while containing DEF, so purging is not required.

DEF Tank

Engines that are compliant with EPA10 and newer regulations are equipped with a DEF tank located on the driver's side of the vehicle behind the battery box or forward of the fuel tank. See Fig. 11.8 and Fig. 11.9. The DEF tank has a 19 mm filler neck inlet that prevents the hose from a diesel outlet from being inserted, and has a blue cap for easy identification.

Fuel/DEF Gauge

The diesel fuel and DEF levels are measured in a dual-purpose gauge. See Fig. 11.10.





Fuel level is indicated at the top of the gauge. Below the fuel level, a low fuel warning lamp illuminates

amber when the fuel level drops below 1/8th of the capacity.

The lower portion of the gauge has a DEF warning lamp that illuminates amber when the DEF tank is near empty, and a lightbar that indicates the level of DEF in the tank. The DEF light bar illuminates as follows:

- Four bars illuminated green—Between 75% and 100% full
- Three bars illuminated green—Between 50% and 75% full
- Two bars illuminated green—Between 25% and 50% full
- One bar illuminated green—Between approximately 10% and 25% full
- One bar illuminated amber—DEF very low, refill DEF
- One bar flashing red—DEF empty, refill DEF

Emissions and Fuel Efficiency

EXHAUST AFTERTREATMENT SYSTEM INFORMATION					
INDICATOR LAMP(S)	 (Solid) Level 1	 (Flashing) Level 2	 (Flashing) CHECK Level 3	 (Flashing) CHECK STOP Level 4	 WARNING
Indicator Lamp Message(s)	Filter Regeneration Recommended	Filter Regeneration Necessary	Parked Regeneration Required – Engine Derate	Parked Regeneration Required – Engine Shut Down	HEST (High Exhaust System Temperature)
Diesel Particulate Filter Condition	Filter is reaching capacity.	Filter is now reaching maximum capacity.	Filter has reached maximum capacity.	Filter has exceeded maximum capacity.	Flashing A regeneration is in progress.
Required Action	Bring vehicle to highway speeds to allow for an Automatic Regeneration or perform a Parked Regeneration.	To avoid engine derate bring vehicle to highway speeds to allow for an Automatic Regeneration or perform a Parked Regeneration as soon as possible.	Vehicle must be parked and a Parked Regeneration must be performed – engine will begin derate.	Vehicle must be parked and a Parked Regeneration or Service Regeneration must be performed. Check engine operator's manual for details –engine will shut down.	Solid Exhaust Components and exhaust gas are at high temperature. When stationary, keep away from people and flammable materials or vapors.
For a driver performed Parked Regeneration, vehicle must be equipped with a dash mounted Regeneration Switch.					
See Engine Operator's Manual for complete Regeneration Instructions.					

24-01583-0008

06/29/2009

f080147

Fig. 11.4, ATS Warning Lamps

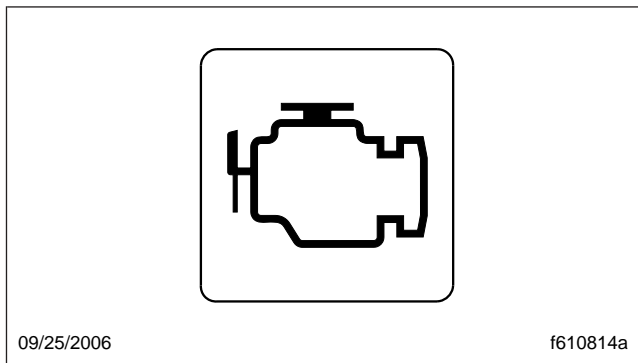

Fig. 11.5, Malfunction Indicator Lamp (MIL)

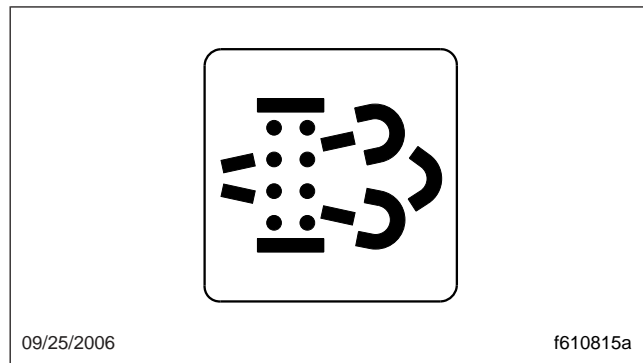

Fig. 11.6, DPF Status Lamp

DEF Warnings and Engine Limits

IMPORTANT: Ignoring the DEF warning lights results in limited engine power, with the application of a 5 mph (8 km/h) speed limit after the engine is shut down and started again.

DEF Level Low—Initial Warning

When the DEF level is low, the following lamps notify the driver. See [Fig. 11.11](#). Refill the DEF tank in order to cancel the warning sequence.

- One bar of the DEF level indicator illuminates amber—DEF very low, refill DEF
- The DEF warning lamp illuminates solid amber

DEF Empty

When the DEF level reads empty, the following lamps notify the drive. See [Fig. 11.12](#).

- One bar of the DEF level indicator flashes red—DEF empty, refill DEF
- The DEF warning lamp flashes amber

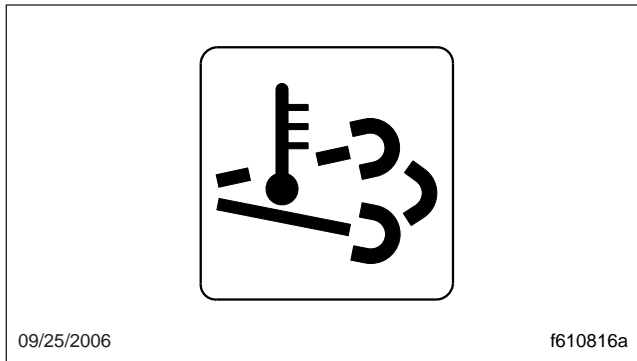

Fig. 11.7, HEST Lamp

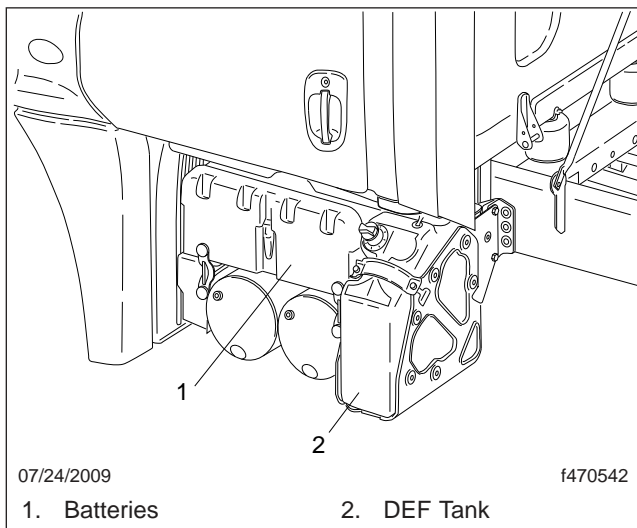

Fig. 11.8, DEF Tank Located Behind the Battery Box

- The MIL lamp illuminates

Pre-2013 Detroit engines: Power is limited, with a 55 mph (90 km/h) speed limit.

Cummins and 2013 Detroit engines: Power is limited with progressively harsher engine power limits applied.

DEF Tank Empty and Ignored

If the empty warning is ignored and the DEF tank is not refilled, the red STOP engine lamp illuminates in addition to the MIL lamp and CHECK engine lamp (on vehicles with a Cummins ISB or ISC/L engine). See Fig. 11.13.

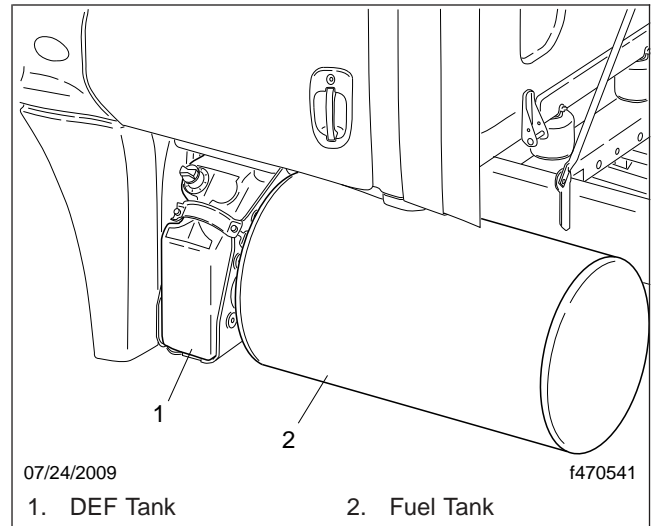

Fig. 11.9, DEF Tank Located Forward of the Fuel Tank

If the DEF is not refilled, a 5 mph (8 km/h) speed limit is applied after the next engine shutdown or if a fuel refill is detected.

DEF Contamination or SCR Tampering

NOTICE

Once contaminated DEF or tampering has been detected, the vehicle must be taken to an authorized service facility to check the SCR system for damage and to deactivate the warning lights and engine limits.

If contaminated DEF or tampering with the ATS is detected, the DEF warning light flashes and the MIL lamp illuminates to warn the driver. The CHECK engine lamp also illuminates on vehicles with a Cummins ISB or ISC/L engine. See Fig. 11.13.

- Detroit engines: Engine power is limited with progressively harsher limits applied. If the fault is not corrected, the STOP engine light illuminates and a 5 mph (8 km/h) speed limit is applied after the next engine shutdown, while parked and idling, or if a fuel refill is detected.
- Cummins engines: Engine power is limited with progressively harsher limits applied. If the fault is not corrected, the STOP engine light illuminates and a 5 mph (8 km/h) speed limit is applied after the next engine shutdown, or while parked and idling.

Emissions and Fuel Efficiency

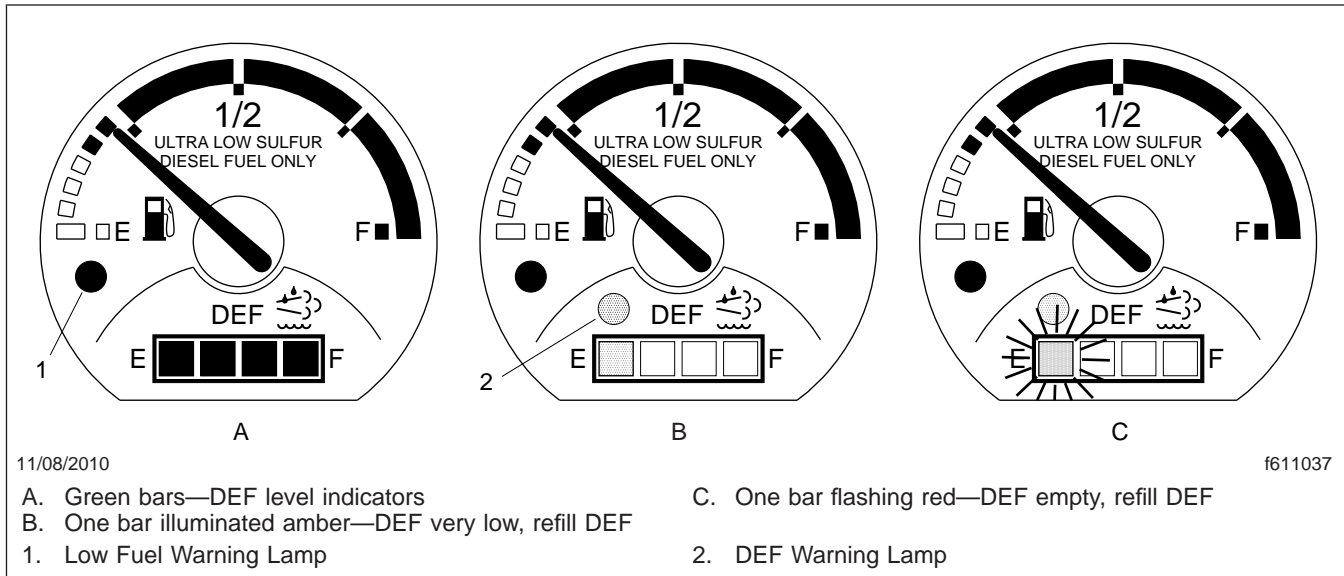

Fig. 11.10, Fuel/DEF Gauge

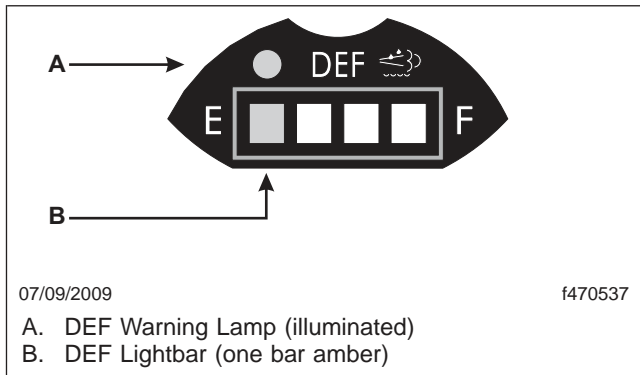

Fig. 11.11, DEF Level Low Initial Warning

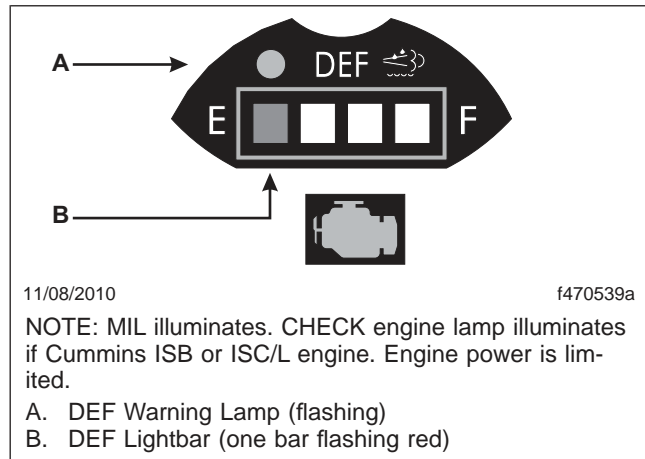

Fig. 11.12, DEF Empty Warning

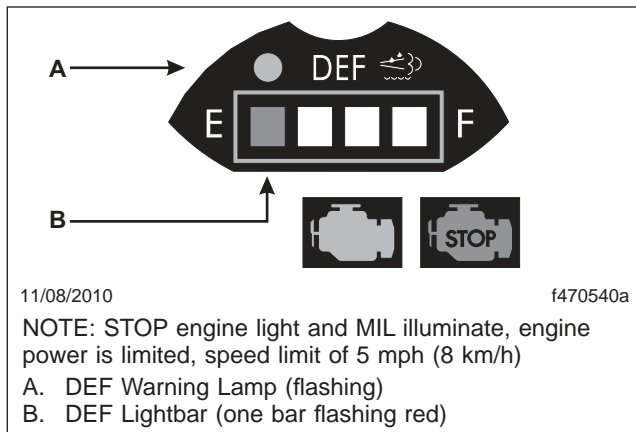

Fig. 11.13, DEF Empty and Ignored Warning

12

Brake Systems

Air Brake System	12.1
Meritor WABCO® Antilock Braking System	12.3
Enhanced Stability Control	12.4
Roll Stability Advisor/Control	12.5

Brake Systems

Air Brake System

Brake System General Information

A dual air brake system consists of two independent air systems that use a single set of brake controls. Each system has its own reservoirs, plumbing, and brake chambers. The primary system operates the service brakes on the rear axle; the secondary system operates the service brakes on the front axle. Service brake signals from both systems are sent to the trailer.

WARNING

Do not operate the vehicle with the front brakes backed off or disconnected. Backing off or disconnecting the front brakes will not improve vehicle handling and may lead to loss of vehicle control, resulting in property damage or personal injury.

Brake System Conditions

The warning light and buzzer come on if air pressure drops below 64 to 76 psi (441 to 524 kPa) in either system. If this happens, check the dual system air pressure gauge to determine which system has low air pressure. Although the vehicle's speed can be reduced using the foot brake control pedal, either the front or rear service brakes will not be operating at full capacity, causing a longer stopping distance. Bring the vehicle to a safe stop and have the air system repaired before continuing.

IMPORTANT: In the event of a total loss of service brakes with full system air pressure, use the parking brake control valve (yellow knob) to bring the vehicle to a complete stop in the safest location possible.

Before a vehicle with insufficient system air pressure can be moved, the spring parking brakes must be released by applying an external air source at the gladhands, or by manually caging the parking brake springs.

WARNING

Do not release the spring parking brakes and then drive the vehicle. There would be no means of stopping the vehicle, which could result in serious personal injury or vehicle damage. Before

releasing the spring parking brakes, make the connection to a towing vehicle or chock the tires.

After correcting the brake system problem, uncage the spring parking brakes before resuming normal vehicle operation.

Primary Air Brake System

Loss of air pressure in the primary air system causes the rear service brakes to become inoperative. The secondary air system will continue to operate the front brakes and the trailer brakes (if equipped).

Secondary Air System

Loss of air pressure in the secondary air system causes the front axle brakes to become inoperative. The primary air system will continue to operate the rear service brakes and the trailer brakes (if equipped).

Brake System Operation

Before driving your vehicle, allow time for the air compressor to build up a minimum of 100 psi (689 kPa) pressure in both the primary and secondary systems. Monitor the air pressure system by observing the dual system air pressure gauge and the low-air-pressure warning light and buzzer. The warning light and buzzer shut off when air pressure in both systems reaches 64 to 76 psi (441 to 524 kPa).

IMPORTANT: Before driving the vehicle, secure all loose items in the cab so that they will not fly forward during a full brake application. Make sure all passengers are wearing seat belts.

During normal brake stops, depress the foot brake control pedal until braking action slows down the vehicle. Increase or decrease the pressure on the pedal so that the vehicle comes to a smooth, safe stop. Apply the spring parking brakes if the vehicle is to be parked.

IMPORTANT: An air brake proportioning system may be used in tractor air brake systems when the vehicle is not equipped with antilock braking system (ABS). When operating in bobtail mode, the rear brake chambers (on which the axle load has been greatly reduced) receive reduced (proportional) air pressure, while the front axle brake chambers receive full (normal) air pressure. This results in a different brake pedal "feel," as the pedal seems to require more travel

and/or effort to slow or stop the vehicle. However, the air brake proportioning system actually improves vehicle control when the tractor is in bobtail mode. When the tractor is towing a trailer, the rear brake chambers will receive full (normal) application air pressure.

When parking a vehicle attached to a trailer that does not have spring parking brakes, apply the tractor parking brakes. Chock the trailer tires before disconnecting the vehicle from the trailer.

WARNING

If a trailer or combination vehicle is not equipped with spring parking brakes, do not park it by pulling out only the trailer air supply valve knob. This would apply only the trailer service brakes. If air were to bleed from the trailer brake system, the trailer brakes would release, possibly causing an unattended runaway vehicle.

NOTICE

Never apply the service and spring parking brakes simultaneously. To do so transmits excessive input force to the brake components, which could damage or cause eventual failure of brake actuating components.

Brake Controls

The trailer brake lever (hand control valve) is used for applying the trailer brakes without applying the truck or tractor service brakes. It is usually mounted on the right-hand control panel. See [Fig. 12.1](#). The valve can be partially or fully applied, but in any partially on position it will be overridden by a full application of the service brake pedal. Moving the lever down applies the trailer brakes, while moving it up releases the trailer brakes. The lever will automatically return to the up position when it is released.

WARNING

Do not use the trailer service brakes for parking; they are not designed for this purpose. If air bleeds out of the trailer air tank during parking, the vehicle could roll, causing serious personal injury or property damage.

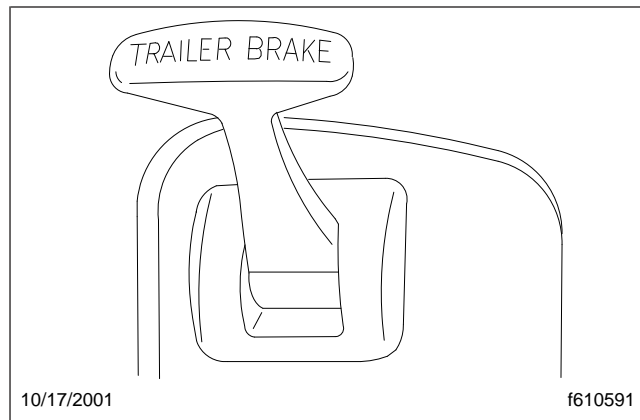

Fig. 12.1, Trailer Brake Lever

The red octagonal-shaped knob in the control panel actuates the trailer air supply valve. See [Fig. 12.2](#). After the vehicle's air hoses are connected to a trailer and the pressure in both air systems is at least 65 psi (448 kPa), the trailer air supply valve must be pushed in. It should stay in to charge the trailer air supply system and to release the trailer spring parking brakes.

Pull the trailer air supply valve out before disconnecting a trailer or when operating a vehicle without a trailer. If pressure in both air systems drops to 35 to 45 psi (242 to 310 kPa), the trailer air supply valve automatically pops out, exhausting the trailer air supply, and applying the trailer service or spring parking brakes.

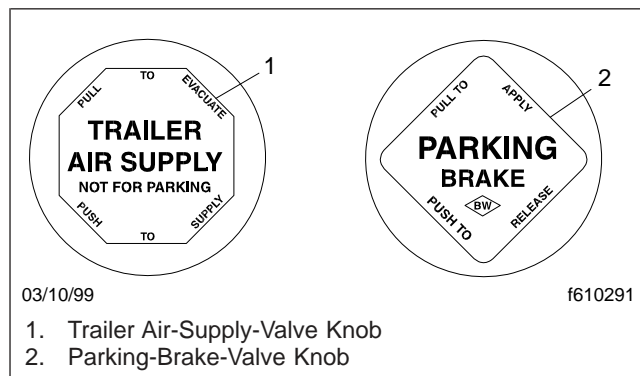

Fig. 12.2, Brake Valve Knobs

The yellow diamond-shaped knob in the control panel actuates the parking brake valve. See [Fig. 12.2](#). Pulling out the parking brake valve applies both the tractor and trailer spring parking brakes and

Brake Systems

automatically causes the trailer air supply valve to pop out.

NOTICE

Do not use the spring parking brakes if the service brakes are hot, such as after descending a steep grade. To do so could damage the brakes. Allow hot brakes to cool before using the spring parking brakes.

Do not use the spring parking brakes during freezing temperatures if the service brakes are wet. To do so could cause them to freeze. If the brakes are wet, drive the vehicle in low gear and lightly apply the brakes to heat and dry them.

If the trailer is not equipped with spring parking brakes, pulling out the parking brake valve applies the tractor spring parking brakes and the trailer service brakes. When the tractor and trailer parking brakes (or trailer service brakes) are both applied, the trailer brakes are released by pushing in the trailer air supply valve, leaving the tractor parking brakes applied. Air pressure in the primary or secondary reservoir must be at least 65 psi (447 kPa) before the tractor spring parking brakes, or the trailer service or spring parking brakes, can be released.

Automatic Slack Adjusters

Automatic slack adjusters should never be manually adjusted except during routine maintenance of the foundation brakes (e.g., replacing shoes), during slack adjuster installation, or in an emergency situation.

When the brake pushrod stroke exceeds the legal brake adjustment limit on a vehicle, there is likely a mechanical problem with the foundation brake components or the adjuster is improperly installed.

Visit a repair facility as soon as possible when brakes equipped with automatic slack adjusters are determined to be out of adjustment.

NOTICE

Manually adjusting an automatic slack adjuster to bring the pushrod stroke within legal limits is not repairing. In fact, continual adjustment of automatic slack adjusters may result in premature wear of the adjuster itself. Further, the improper adjustment of some automatic slack adjusters

may cause internal damage to the adjuster, thereby preventing it from properly functioning.

Meritor WABCO® Antilock Braking System

The Meritor WABCO Antilock Braking System (ABS) is an electronic wheel speed monitoring and control system that works with the standard air brake system. ABS passively monitors vehicle wheel speed at all times, and controls wheel speed during emergency stops or wheel lock situations.

IMPORTANT: For proper ABS system operation, do not change tire sizes. The sizes of the tires installed during production are programmed into the electronic control unit. Installing different-sized tires could result in a reduced braking force, leading to longer stopping distances.

ABS includes signal-generating tone wheels and sensors located in the wheel hubs of each sensed wheel. The sensors transmit vehicle wheel speed information to an electronic control unit (located behind the center dash). The control unit's main circuit interprets the speed sensor signals and calculates wheel speed, wheel retardation, and a vehicle reference speed. If the calculations indicate wheel lockup, the main circuit signals the appropriate modulator valve to reduce braking pressure. During emergency braking, the modulator valve alternately reduces, increases, or maintains air pressure supply in the brake chamber to prevent front and rear wheel lockup.

The electronic control unit also has a safety circuit that constantly monitors the wheel sensors, traction control valve (if equipped), modulator valves, and the electrical circuitry.

The Meritor WABCO ABS combines one front-axle control channel with one rear-axle control channel to form one control circuit. For example, the sensor and modulator valve on the left-front axle form a control circuit with the sensor and modulator valve on the right-rear axle. If, during vehicle operation, the safety circuit senses a failure in any part of the ABS, the tractor warning lamp (TRACTOR ABS) illuminates and the control circuit where the failure occurred is switched to normal braking action. The remaining control circuit will retain the ABS effect. Even if the ABS is completely inoperative, normal braking ability is maintained. An exception would be if a modulator

valve (or combination modulator valve) is damaged and inoperative. As these components are an integral part of the air brake system, normal braking may be impaired or inoperative.

During emergency or reduced-traction stops, fully depress the brake pedal until the vehicle comes to a safe stop. *Do not pump the brake pedal.* With the brake pedal fully depressed, the ABS will control all wheels to provide steering control and a reduced braking distance.

Although the ABS improves vehicle control during emergency braking situations, the driver still has the responsibility to change driving styles depending on existing traffic and road conditions. For example, the ABS cannot prevent an accident if the driver is speeding or following too closely.

Trailer ABS Compatibility

The Meritor WABCO ABS is designed to communicate with a trailer ABS, if they are compatible. Compatibility will result in the illumination of the TRAILER ABS lamp during vehicle start-up and fault detection.

The TRAILER ABS lamp will not illuminate unless a compatible trailer is connected to the tractor. The dash-mounted lamp will operate as follows when a compatible trailer is properly connected to the tractor:

- When the ignition key is turned to the ON position, the TRAILER ABS lamp will illuminate momentarily, then turn off.
- If the lamp illuminates momentarily during vehicle operation, then shuts off, a fault was detected and corrected.
- If the lamp illuminates and stays on during vehicle operation, there is a fault with the trailer ABS. Repair the trailer ABS system immediately to ensure full antilock braking capability.

IMPORTANT: If a compatible trailer is connected, and the lamp is not illuminating momentarily when the ignition key is turned to the ON position, it is possible that the lamp is burnt out.

Automatic Traction Control

Vehicles with electronic engines and ABS may have Automatic Traction Control (ATC). On these vehicles, the ATC system automatically limits wheel spin during reduced-traction situations. In normal braking applications, the standard air brake system is in effect.

An additional solenoid valve is installed. During reduced-traction situations, the ATC solenoid valve controls air pressure to the modulator valves and they in turn increase, hold, or reduce pressure to the appropriate brake chambers to provide better traction whenever wheel spin occurs.

When the ATC system is in the NORMAL mode, it will apply gentle braking to the spinning wheel, to feed power to the wheel(s) with better traction. If both wheels are spinning, the system will signal the engine to reduce power.

ATC includes a deep snow and mud option to increase available traction on extra soft surfaces like snow, mud, or gravel. A momentary contact rocker switch labeled ATC will be located on the dash. Pressing the switch will temporarily allow more drive wheel spin. The activation of the deep snow and mud option is indicated by a flashing WHEEL SPIN lamp. Pressing the switch again will cycle the system back to normal operation.

NOTICE

The deep snow and mud option is intended to be used under specific slippery conditions that require momentary increased wheel spin. Using this option for an extended period of time may damage the vehicle brake system.

After the ignition switch is turned on, the TRACTOR ABS lamp and the WHEEL SPIN indicator lamp come on for about three seconds. After three seconds, the warning lights go out if all of the tractor's ABS components are working.

IMPORTANT: If any of the ABS warning lights do not work as described above, or come on while driving, repair the ABS immediately to ensure full antilock braking capability.

Enhanced Stability Control



The Enhanced Stability Control system is intended only as an aid for a conscientious and alert driver and is not a substitute for safe driving procedures. Failure to drive safely, and use the system properly, could result in personal injury and/or death and property damage.

Brake Systems

The Enhanced Stability Control (ESC) system offers the capability of complete directional stability (yaw control) in oversteer and understeer conditions to reduce the likelihood of drift-out or jackknife. The system determines where the driver is attempting to steer the vehicle and how much brake demand is required in order to more precisely control the vehicle in an emergency situation.

ESC works by constantly comparing the driver's intention with the vehicles' actual behavior. The system does this by monitoring systems such as wheel speed, steering angle, yaw rate, lateral acceleration, throttle position, and brake application. A central microcomputer analyzes the collected data and triggers a response to keep the vehicle on course when an unstable condition is detected.

When the system detects that the vehicle is at risk of rolling over, it applies individual tractor wheel end brakes and trailer brakes, activates the engine retarder (if equipped), and/or cuts engine power, depending on the severity. As a result, the driver has full control over the vehicle until the system detects a potential rollover and intervenes accordingly. ESC operates automatically; the driver does not monitor or activate the system.

Roll Stability Advisor/Control

The enhanced stability system may include the roll stability advisor (RSA) only, or it may also include the roll stability control (RSC).

A decal (Fig. 12.3) on the auxiliary dash panel, and an amber-colored dash indicator light (Fig. 12.4), indicate that the vehicle is equipped with roll stability system components. On these vehicles, the roll stability indicator light replaces the wheel spin indicator light.

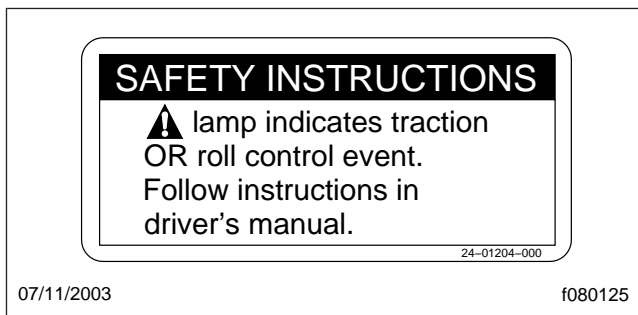

Fig. 12.3, Roll Stability Decal



Fig. 12.4, Roll Stability Indicator Lamp

Roll Stability Advisor

IMPORTANT: This is not an advance warning system. The roll stability advisor displays a message only after the driving maneuver is completed.

The roll stability system uses a lateral-acceleration sensor that monitors rollover risk. Shortly after a curve, lane change, or other driving maneuver that results in a rollover-risk detection, a dash warning light illuminates, an audible tone sounds, and a driver advisory message is displayed in the driver message center. The purpose is to advise the driver that the previous maneuver produced a rollover risk.

The roll stability advisor displays different text messages depending on the severity of the risk of each occurrence of risky driving. From the highest risk level to the lowest risk level, the system will sound an audible alert, and display a message, as shown in Fig. 12.5.

NOTE: The system will calculate and recommend a speed reduction value. It may be different than the values shown here.

Bring the vehicle to an authorized service facility if a system failure message is displayed.

Roll Stability Control



The Roll Stability Control system is intended only as an aid for a conscientious and alert driver. Carefully read the information in this manual to understand this system and its limitations. The Roll Stability Control system is not a substitute for safe driving procedures. Failure to drive

MSG No.	Message	Message to Display	Display Time: Seconds	Buzzer Time: Seconds
1	System Fault	<div style="border: 1px solid black; padding: 2px; text-align: center;">WARNING</div> <div style="border: 1px solid black; padding: 2px; text-align: center;">RAC SYSTEM FAIL</div>	4	1
2	RSC	<div style="border: 1px solid black; padding: 2px; text-align: center;">ACTIVE SLOWING</div> <div style="border: 1px solid black; padding: 2px; text-align: center;">ROLLOVER RISK</div>	4	None
3	RSA Level 3	<div style="border: 1px solid black; padding: 2px; text-align: center;">VERY HIGH RISK OF + ROLLOVER DETECTED</div> <div style="border: 1px solid black; padding: 2px; text-align: center;">REDUCE SPEED + AT LEAST 7 MPH</div> <p style="text-align: center;">or in metric</p> <div style="border: 1px solid black; padding: 2px; text-align: center;">REDUCE SPEED + AT LEAST 11 KPH</div>	19.6	10
4	RSA Level 2	<div style="border: 1px solid black; padding: 2px; text-align: center;">HIGH RISK OF + ROLLOVER DETECTED</div> <div style="border: 1px solid black; padding: 2px; text-align: center;">REDUCE SPEED + AT LEAST 7 MPH</div> <p style="text-align: center;">or in metric</p> <div style="border: 1px solid black; padding: 2px; text-align: center;">REDUCE SPEED + AT LEAST 11 KPH</div>	14	5
5	RSA Level 1	<div style="border: 1px solid black; padding: 2px; text-align: center;">ROLLOVER RISK + DETECTED</div> <div style="border: 1px solid black; padding: 2px; text-align: center;">REDUCE SPEED + AT LEAST 7 MPH</div> <p style="text-align: center;">or in metric</p> <div style="border: 1px solid black; padding: 2px; text-align: center;">REDUCE SPEED + AT LEAST 11 KPH</div>	8.4	2
6	HBED Level 3	<div style="border: 1px solid black; padding: 2px; text-align: center;">HARD BRAKING WITH + ABS ACTIVATED</div> <div style="border: 1px solid black; padding: 2px; text-align: center;">LOOK AHEAD + BRAKE SOONER</div>	14	0.5
7	HBED Level 2	<div style="border: 1px solid black; padding: 2px; text-align: center;">HARD BRAKING + DETECTED</div> <div style="border: 1px solid black; padding: 2px; text-align: center;">LOOK AHEAD + BRAKE SOONER</div>	14	0.5
8	HBED Level 1	<div style="border: 1px solid black; padding: 2px; text-align: center;">LOSS OF TRACTION + ABS ACTIVATED</div> <div style="border: 1px solid black; padding: 2px; text-align: center;">ROAD SURFACE + MAY BE POOR</div>	14	0.5

07/25/2008 f040769

Fig. 12.5, Roll Stability and Hard-Braking Warnings

safely, and use the system properly, could result in personal injury and/or death and property damage.

The roll stability control system automatically reduces engine power, applies the engine brake, and/or applies the tractor and trailer brakes when the acceleration sensor detects that the vehicle is at risk of rolling over. The control can intervene even before an advisory message is displayed.

The dash indicator light illuminates whenever the roll stability control system intervenes.

Hard-Braking Advisor

The hard-braking advisor uses the information from the ABS wheel speed sensors to determine when braking is severe enough to produce lockup at one or more wheels on the tractor, and/or very rapid vehicle deceleration. Shortly after a hard-braking event occurs, an advisory message is displayed in the driver message center, indicating that the braking behavior was too aggressive for the current road surface conditions. This system is not a replacement for a driver's good judgment. Sometimes it is necessary to brake hard.

From the highest risk level to the lowest risk level, the system will sound an audible alert, and display a message, as shown in [Fig. 12.5](#).

Trip/Leg Totals

The driver message center records the number of messages received, and displays the number of messages as counts. Roll stability advisor (RSA) and hard-braking event data (HBED) counts can be viewed in the trip advisory screen, and the leg advisory screen.

Counts can be reset using the + key on the steering wheel. Clearing RSA and HBED leg counts will also reset the leg miles and leg hours. Clearing RSA and HBED trip counts will also reset trip miles, trip hours, leg miles, leg hours, and leg advisory counts. In addition, resetting leg miles will clear leg counts. Clearing trip miles will reset miles, hours, and counts in both the leg and trip screens.

The TRIP and LEG advisor screens count both the roll stability advisories (ROLL) and hard-braking events (BRK). For example, if during a TRIP, the driver message center recorded the events in [Table 12.1](#), the message center would display as shown in [Fig. 12.6](#).

Brake Systems

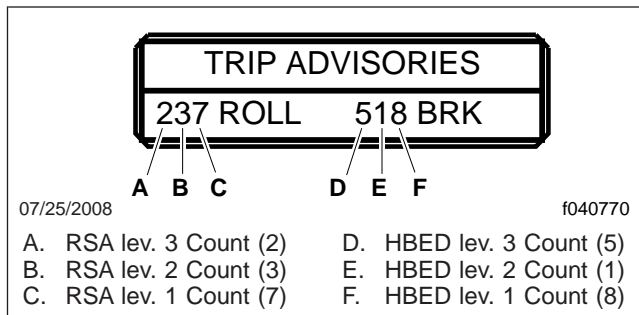

Fig. 12.6, Trip Advisor Message Screen

RSA/HBED Count	
Message Received	Message Counts
RSA Level 3	2
RSA Level 2	3
RSA Level 1	7
HBED Level 3	5
HBED Level 2	1
HBED Level 1	8

Table 12.1, RSA/HBED Count

If the count reaches more than 9 occurrences an up-arrow symbol will appear, to indicate to the driver that the count has exceeded 9 counts. See [Fig. 12.7](#).

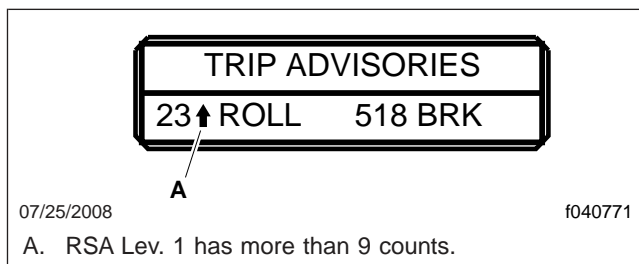

Fig. 12.7, Trip Advisor Message Screen (more than 9 counts)

13

Manual Transmissions and Clutch

Eaton Fuller 13-Speed and 18-Speed Splitter and Range-Shift Transmissions	13.1
Eaton Fuller 10-Speed Range-Shift Transmissions	13.4
Clutch	13.5

Manual Transmissions and Clutch

Eaton Fuller 13-Speed and 18-Speed Splitter and Range-Shift Transmissions

For complete information on Eaton transmissions, go to the Eaton website, www.roadranger.com.

General Information, Eaton Fuller Splitter and Range-Shift Transmissions

Combination splitter and range-shift transmissions allow the choice of two splitter ratios in each shift knob position, as well as the additional ratios provided by a low range and a high range.

IMPORTANT: Not all ratios are used in each range, and the shift patterns vary between transmissions. Read the shift pattern decal on the dash for the operating instructions for the transmission installed in your vehicle.

Range-Shift

The range-preselection lever selects the low or high range for each transmission ratio. It is used once during an upshift sequence and once during a downshift sequence.

The range-preselection lever is down when in the low range, and up when in the high range.

IMPORTANT: Always preselect range shifts when upshifting or downshifting. Preselection requires that the range lever be moved to the necessary position before starting to shift.

When correctly preselected, range shifts are completed automatically as the lever is moved through neutral and into the next gear. Preselecting range shifts prevents damage to the transmission and provides for smoother shifts.

IMPORTANT: Never make a range shift while moving in reverse.

Splitter Control

Dependent on the transmission model, some ratios can be split using the splitter-control button (located on the side of the shift knob).

IMPORTANT: Always preselect splitter shifts. Preselection requires that the splitter-control button be moved to the necessary position before starting to shift.

Preselecting splitter shifts allows for smoother and faster shifting. However, do not delay: complete the shift immediately after preselecting the split to avoid unnecessary wear on transmission components.

IMPORTANT: Never make a splitter shift while moving in reverse.

13-Speed RTLO Models

Eaton Fuller 13-speed transmissions have thirteen forward speeds and two reverse speeds. Each transmission consists of a 5-speed front section and a 3-speed auxiliary section. The auxiliary section contains low- and high-range ratios, plus a splitter gear. See [Fig. 13.1](#) for the shift pattern.

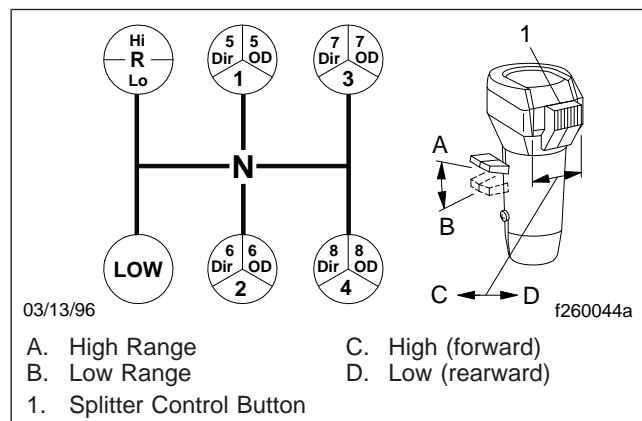

Fig. 13.1, Eaton Fuller 13-Speed Transmission Shift Pattern

All thirteen speeds are controlled with one shift knob.

LOW gear in the front section is used only as a starting gear; it is never used when the transmission is in high range. The other four ratios are used once in the low range and once again in the high range.

When in the high range, the gear ratios can be split by using the splitter-control button with the under-drive ratio (RT models), or overdrive ratio (RTO models). When in the low range, the gear ratios cannot be split.

IMPORTANT: The shift knob has an interlock feature that prevents the splitter-control button

Manual Transmissions and Clutch

from being activated when the range-preselection lever is down (in low range). When in high range with the splitter-control button activated, the range-preselection lever cannot be moved down.

18-Speed RTLO Splitter and Range-Shift Models

Eaton Fuller 18-speed transmissions have eighteen forward speeds and four reverse speeds. Each transmission consists of a 5-speed front section and a 4-speed auxiliary section. The auxiliary section contains low- and high-range ratios, plus a splitter gear.

All eighteen speeds are controlled with one shift knob. All nine ratios in both the low and high ranges can be split.

LOW gear in the front section is used only as a starting gear; it is never used when the transmission is in high range. LOW gear can be split, to provide both a direct and an overdrive ratio.

Operation Tips, Eaton Fuller Splitter and Range-Shift Transmissions

The following tips highlight important operation principles.

- For all conditions, use the highest gear that is still low enough to start the vehicle moving with the engine at or near idle speed, and without slipping the clutch excessively.

When operating on-highway with no load or under ideal conditions, use 1st gear to start the vehicle moving forward.

When operating off-road or under adverse conditions, use LOW gear to start the vehicle moving forward.

- Use the clutch brake to stop gear rotation when shifting into LOW or reverse while the vehicle is stationary. The clutch brake is actuated by depressing the clutch pedal all the way to the floor.
- Partially disengage the clutch to break engine torque during normal gear shifts.
- Double-clutch between all upshifts and downshifts that require movement of the shift knob. Splitting of gears does not require movement of the shift knob.

- Never push the range-preselection lever down into low range while operating in high range, except when downshifting from 5th gear to 4th gear.
- Do not shift from high range to low range at high vehicle speeds.
- Preselect all range and splitter shifts. Move the range-preselection lever and/or splitter-control button to the needed position before starting to shift.
- Never make a range shift or a splitter shift while the vehicle is in reverse.
- Never move the range-preselection lever with the shift knob in neutral while the vehicle is moving.
- Skip ratios while shifting *only* when operating conditions permit, depending on the load, grade, and road speed.
- Never coast with the shift knob in the neutral position.

Upshifting

1. Position the gear shift knob in neutral. Start the engine and bring the air system pressure up to 100 to 120 psi (689 to 827 kPa).
2. Position the range-preselection lever down, in low range. See [Fig. 13.2](#).

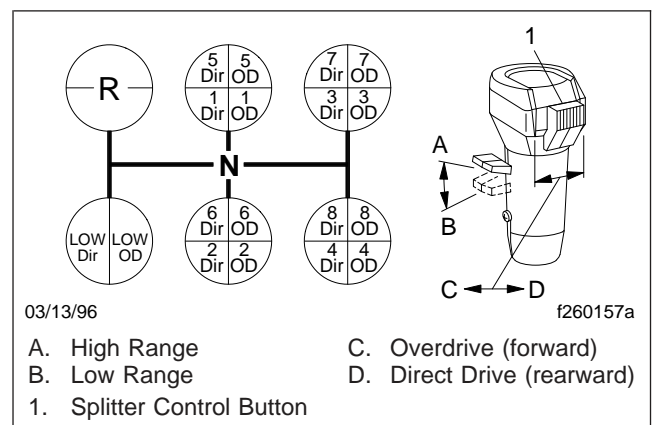

Fig. 13.2, Eaton Fuller 18-Speed Transmission Shift Pattern

3. Make sure the splitter-control button is in the low (rearward) position. See [Fig. 13.2](#).

Manual Transmissions and Clutch

4. For 13-speed transmissions:

To start the vehicle moving, press the clutch pedal to the floor, shift into LOW or 1st gear, then engage the clutch with the engine at or near idle speed. Accelerate to 80 percent of engine governed speed.

For 18-speed transmissions:

To start the vehicle moving, press the clutch pedal to the floor, shift into LOW, then engage the clutch with the engine at or near idle speed. To shift from LOW direct to LOW overdrive, move the splitter-control button into the overdrive (forward) position, then immediately release the accelerator. Press and release the clutch pedal. After releasing the clutch pedal, accelerate again.

5. For 13-speed transmissions:

Upshift from LOW (or 1st gear) through 4th gear, double-clutching during knob shifts, and accelerating to 80 percent of engine governed speed. See [Fig. 13.1](#).

For 18-speed transmissions:

Upshift from LOW overdrive to 1st direct by first moving the splitter-control button into the direct drive (rearward) position ([Fig. 13.2](#)). Double-clutch and move the shift knob through neutral to the 1st gear position.

Continue upshifting through the shift pattern. Double-clutch during knob shifts (1st to 2nd to 3rd to 4th); single-clutch during split shifts (1st direct to 1st overdrive, etc.).

6. When in 4th gear (13-speed transmissions) or 4th overdrive (18-speed transmissions), use the range-preselection lever and the splitter-control button to upshift to 5th gear.

While in 4th gear, pull the range-preselection lever up into high range and move the splitter-control button to the low (rearward) position. Double-clutch through neutral and into 5th gear, engage the clutch, and accelerate the engine.

7. Upshift progressively through the high range gears.

To shift from 5th direct to 5th overdrive (or 5th underdrive to 5th direct on RT model transmissions), move the splitter-control button to the high (forward) position, then immediately release the accelerator. Press and release the clutch

pedal. After releasing the clutch, accelerate again.

Continue upshifting through the shift pattern. Double-clutch during knob shifts (6th to 7th, etc.); single-clutch during split shifts (6th direct to 6th overdrive, etc.).

Downshifting

IMPORTANT: Never use the clutch brake when downshifting, or as a brake to slow the vehicle.

1. To downshift from 8th overdrive to 8th direct (or 8th direct to 8th underdrive on RT model transmissions), move the splitter-control button to the low (rearward) position, then immediately release the accelerator. Press and release the clutch pedal, then accelerate the engine once the transmission has shifted.
2. Start the downshift from 8th direct to 7th overdrive by moving the splitter-control button to the high (forward) position, then immediately double-clutch through neutral, moving the shift knob from 8th gear to 7th gear.
3. Downshift progressively through each of the high range gears, alternating the procedures in steps 1 and 2 above until reaching 5th direct.
4. When in 5th direct and ready for the downshift to 4th (13-speed transmissions) or 4th overdrive (18-speed transmissions), push the range-preselection lever down and move the splitter-control button to the high (forward) position. Double-clutch through neutral and into 4th gear, engage the clutch, and accelerate the engine.
5. Continue downshifting from 4th gear to 1st gear.

For 13-speed transmissions:

Downshift through the low range gears as conditions require.

For 18-speed transmissions:

Continue downshifting from 4th overdrive to 4th direct, then 4th direct to 3rd overdrive, etc. Double-clutch during knob shifts (4th to 3th, etc.); single-clutch during split shifts (4th direct to 3rd overdrive, etc.).

Eaton Fuller 10-Speed Range-Shift Transmissions

For complete information on Eaton transmissions, go to the Eaton website, www.roadranger.com.

General Information, 10-Speed Range-Shift Transmissions

Eaton Fuller 10-speed transmissions have ten forward speeds and two reverse speeds. Each transmission has a 5-speed front section and a 2-speed auxiliary section.

A range-shift transmission allows for additional ratios provided by a low range and a high range. The ten forward speeds are obtained by twice using a 5-speed shift pattern: first in the low range, then in the high range. See [Fig. 13.3](#) for the shift patterns.

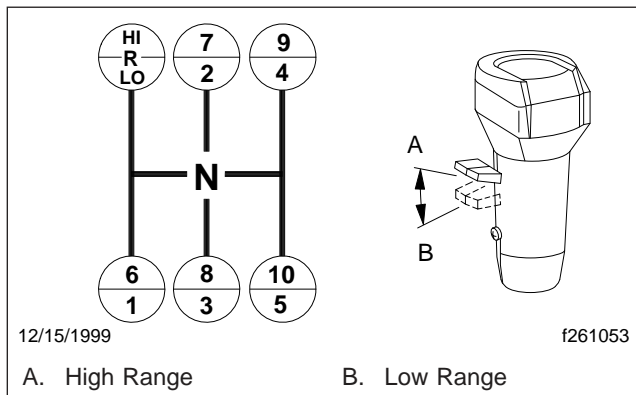

Fig. 13.3, Eaton Fuller 10-Speed Transmission Shift Patterns

The range-preselection lever selects the low or high range for each ratio. It is used once during an upshift sequence and once during a downshift sequence. The range-preselection lever is down when in the low range, and up when in the high range.

IMPORTANT: Always preselect range shifts when upshifting or downshifting. Preselection requires that the range lever be moved to the necessary position before starting to shift.

When correctly preselected, range shifts are completed automatically as the lever is moved through neutral and into the next gear. Preselecting range shifts prevents damage to the transmission and provides for smoother shifts.

To operate a range-shift transmission, move the shift knob through all the low-range gear positions and then pull the range-preselection lever up to move into the high-range ratios. Use the same shift knob positions in both the low and high ranges.

IMPORTANT: Shift patterns vary between transmissions. Be sure to read the shift pattern decal on the dash for the operating instructions for the transmission installed in your vehicle.

NOTE: The 4th/9th and the 5th/10th shift positions in the RT (direct ratio) and RTX (overdrive ratio) transmissions are directly opposite in the RTO (overdrive ratio) transmissions.

Operation Tips, Eaton Fuller Range-Shift Transmissions

The following tips highlight important operation principles.

- For all conditions, use the highest gear that is still low enough to start the vehicle moving with the engine at or near idle speed, and without slipping the clutch excessively.
- Use the clutch brake to stop gear rotation when shifting into LOW or reverse while the vehicle is stationary. The clutch brake is actuated by depressing the clutch pedal all the way to the floor.
- Partially disengage the clutch to break engine torque during normal gear shifts.
- Double-clutch between all upshifts and downshifts.
- Never push the range-preselection lever down into low range while operating in high range, except when downshifting from 5th gear to 4th gear.
- Do not shift from high range to low range at high vehicle speeds.
- Preselect all range shifts. Move the range-preselection lever to the needed position before starting to shift.
- Never make a range shift while the vehicle is in reverse.

Manual Transmissions and Clutch

- Never move the range-preselection lever with the shift knob in neutral while the vehicle is moving.
- Skip ratios while shifting *only* when operating conditions permit, depending on the load, grade, and road speed.
- Never coast with the shift knob in the neutral position.

Upshifting

1. Position the gear shift knob in neutral. Start the engine and bring the air system pressure up to 100 to 120 psi (689 to 827 kPa).
2. Position the range-preselection lever down, in low range. See [Fig. 13.2](#).
3. To start the vehicle moving, press the clutch pedal to the floor; shift into 1st gear ([Table 13.1](#)), then engage the clutch with the engine at or near idle speed. Accelerate to 80 percent of engine governed speed.

Eaton Fuller Shift Progressions		
TRANS. MODEL	LOW RANGE	HIGH RANGE
10-Speed Direct or Overdrive (RT or RTX)	<p>Diagram showing gear shift patterns for Low Range (gears 1-5) and Reverse (R). The pattern is a 'Z' shape: R to 2, 2 to 4, 4 to 3, 3 to 5, 5 to 1, 1 to 3, 3 to 5.</p>	<p>Diagram showing gear shift patterns for High Range (gears 6-10) and Reverse (R). The pattern is a 'Z' shape: R to 7, 7 to 9, 9 to 8, 8 to 10, 10 to 6, 6 to 8, 8 to 10.</p>

Table 13.1, Eaton Fuller Range-Shift Shift Progressions

4. Upshift progressively from 1st gear through 5th gear ([Table 13.1](#)), double-clutching between shifts, and accelerating to 80 percent of engine governed speed.
5. When in 5th gear and ready to move to 6th gear, pull the range-preselection lever up into the high range. Double-clutch through neutral and into 6th gear, engage the clutch, and accelerate the engine.

NOTE: If after attempting to shift into the high range the transmission remains in neutral with the shift knob in gear, the range synchronizer protection device may be activated. Move the shift knob into neutral to allow the range shift to complete, then move the shift knob back into gear.

6. Upshift progressively through the high range gears ([Table 13.1](#)), double-clutching between shifts and accelerating to 80 percent of engine governed speed.

Downshifting

IMPORTANT: Never use the clutch brake when downshifting, or as a brake to slow the vehicle.

1. Downshift progressively through each of the high range gears, double-clutching between shifts.
2. When in 5th gear and ready to move to 4th gear, push the range-preselection lever down into the low range. Double-clutch through neutral and into 4th gear, engage the clutch, and accelerate the engine.

NOTE: If after attempting to shift into the high range the transmission remains in neutral with the shift knob in gear, the range synchronizer protection device may be activated. Move the shift knob into neutral to allow the range shift to complete, then move the shift knob back into gear.

3. Downshift progressively through the low range gears, double-clutching between shifts, as conditions require.

Clutch

Clutch General Information

To ensure long service life of the clutch, start in the right gear, be alert to clutch malfunctions, and know when to adjust the clutch.

Typical operation will not break down the clutch friction surfaces. Heat and wear are almost nonexistent when a clutch is fully engaged. However, during the moment of engagement, when the clutch is picking up the load, considerable heat is generated. If a clutch slips excessively, high temperatures develop quickly between the flywheel, driven discs, and pressure plates. An improperly adjusted or slipping clutch can generate temperatures high enough to cause the friction-facing material to char and burn, destroying the clutch.

Manual Transmissions and Clutch

Clutch Operation

Clutch Break-In

The clutch may slip for a short time while the friction surfaces break-in on a new or newly-installed clutch. However, allowing the clutch to slip for more than two seconds can severely damage the clutch disc, pressure plate, and the flywheel.

NOTICE

Do not allow sustained slippage of the clutch; which will severely damage the clutch disc, pressure plate, or flywheel. Damage caused by clutch slippage due to improper break-in is not warrantable.

During initial operation of a new vehicle or a vehicle with a new clutch, check for clutch slippage during acceleration. If the clutch slips, decelerate until the clutch does not slip. Allow the clutch to cool 15 to 30 seconds, then gradually accelerate again. If the clutch continues to slip, repeat the procedure as many as five times. If the clutch slips after five attempts, stop the vehicle and allow the clutch to cool for at least one hour. Notify your Freightliner dealer of the problem.

Moving the Vehicle in the Proper Gear

An empty vehicle can be started in a higher transmission gear than can a partially- or fully-loaded vehicle. Select the gear combination that allows the vehicle to start moving with an idling engine or, if necessary, just enough throttle to prevent stalling the engine. After the clutch is fully engaged, the engine can be accelerated to the correct rpm for the upshift into a higher gear.

Gear Shifting Techniques

Upshift into a higher gear when the vehicle speed allows the transmission input shaft speed to match the flywheel speed when engaging the clutch. This technique results in the smallest speed difference between the clutch disc and the flywheel, and causes the least heat and wear on the clutch assembly. When downshifting, increase the input shaft speed to match the flywheel by slightly revving the engine. For transmission operating instructions, refer to the transmission headings in this chapter.

Vehicle Loading

Clutches are designed for specific vehicle applications and loads. Do not exceed these weight limitations.

NOTICE

Exceeding vehicle load limits can result in damage to the clutch and the entire powertrain.

Clutch Brake

Apply the clutch brake by depressing the clutch pedal all the way to the floor plate. The last part of the clutch pedal travel will compress the clutch brake plates together, stopping the transmission input shaft. The clutch brake stops the transmission gears from rotating in order to quickly engage a transmission gear after idling in neutral.

NOTICE

Never apply the clutch brake when the vehicle is moving. If the clutch brake is applied when the vehicle is moving, the clutch brake will try to stop or decelerate the vehicle, causing rapid wear of the clutch brake friction discs. Considerable heat will be generated, causing damage to the release bearings and the transmission front bearings.

Using the Clutch

Use the clutch pedal only when starting the engine, launching the vehicle from a stop, or shifting. To launch a stationary vehicle, depress the clutch pedal all the way to the floor plate (see "Using the Clutch Brake" above) and shift from neutral to a low gear. Slowly raise your foot until the clutch starts to engage. In this position the clutch is starting to connect the transmission input shaft to the flywheel and is causing the most heat and wear. Slightly increase the engine speed and smoothly allow the clutch pedal to return to the rest position. Do not allow the clutch to remain in the partially-engaged position any longer than necessary to obtain a smooth start.

Double-clutch to shift gears while the vehicle is moving. Depress the clutch pedal most of the way in, but not all the way to the floor plate. Depressing the clutch pedal to the floor plate will engage the clutch brake. Shift the transmission into neutral and fully

Manual Transmissions and Clutch

release the clutch pedal. When upshifting, wait long enough for the engine speed to decrease to the road speed. When downshifting, increase the engine speed to match the road speed. Again, depress the clutch pedal part way and then move the shift lever to the next gear position. Fully release the clutch pedal after completing the shift.

NOTICE

Riding the clutch while driving is damaging to the clutch because partial clutch engagement causes slippage and heat. Resting your foot on the clutch pedal will also put a constant thrust load on the release bearing, thinning the bearing lubricant and increasing the wear on the bearing.

Holding the Vehicle On an Incline

Always use the vehicle service brakes to prevent the vehicle from rolling backwards while stopped on a hill. Slipping the clutch on a hill to maintain vehicle position will quickly damage the clutch assembly.

Coasting

Coasting with the clutch pedal depressed and the transmission in a low gear can cause high driven disc speed. The clutch speed can be much higher under these conditions than when the engine is driving the clutch. This condition creates a hazardous situation due to the lack of vehicle control and due to the high clutch disc speed. Engaging the clutch under these conditions can cause component damage because of the shock loads to the clutch and drivetrain.

WARNING

Always shift into the gear that is correct for the traveling speed of the vehicle and engage the clutch. Coasting with the clutch disengaged can prevent engagement of the correct transmission gear which can cause loss of vehicle control, possibly resulting in personal injury or property damage.

High clutch disc speeds while coasting can also cause the clutch facing to be thrown off the disc. Flying debris from the clutch can cause injury to persons in the cab.

Clutch Maintenance

Checking the Clutch Adjustment

Report erratic clutch operation as soon as possible to give maintenance personnel a chance to inspect, lubricate, and adjust the clutch components. Notice any gradual decrease in the distance the clutch pedal moves before resistance is felt.

NOTICE

Operating the vehicle with incorrect free pedal could result in clutch damage.

A correctly adjusted clutch must have about 3/4 inch (19 mm) of travel at the top of its stroke before a stronger resistance can be felt. See [Fig. 13.4](#). If the free pedal travel is less than this distance, have the clutch adjusted.

Check the clutch free pedal travel daily and note it in the driver's report.

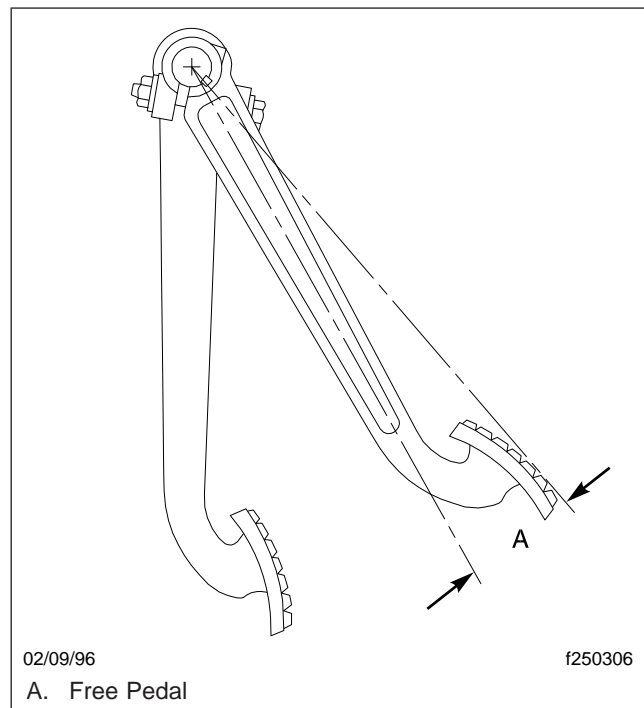

Fig. 13.4, Clutch Free Pedal Travel

Adjusting the Clutch

Clutches have an internal adjustment and external linkage adjustment. See **Group 25** of the *108SD* and

114SD Workshop Manual for clutch adjustment procedures and specifications.

Checking the Clutch Brake Operation

Clutch brake operation can be felt as an increased resistance as the clutch pedal approaches the bottom of its stroke. If the gears grind when shifting into first or reverse gear from neutral with the clutch pedal fully depressed, the clutch pedal is out of adjustment or the clutch brake is worn and needs to be replaced.

Lubricating the Clutch Release Bearing

On vehicles equipped with a greaseable release bearing, the release bearing should be lubricated at frequent intervals. See **Group 25** of the *108SD and 114SD Maintenance Manual* for intervals and procedures.

Automated and Automatic Transmissions

Freightliner SmartShift Shift Control	14.1
Eaton Fuller UltraShift DM Automated Transmissions	14.1
Eaton Fuller UltraShift PLUS Automated Transmissions	14.6
Eaton Fuller AutoShift Automated Transmissions	14.10
Allison Automatic Transmissions	14.13

Automated and Automatic Transmissions

Freightliner SmartShift Shift Control

General Information, SmartShift Control

The SmartShift electronic transmission control is installed with the following transmissions:

- Eaton® Fuller® UltraShift™
- Eaton Fuller UltraShift PLUS
- Eaton Fuller AutoShift™

It replaces the typical floor-mounted shift lever or dash-mounted push button control.

SmartShift accepts driver requests for transmission functions and transmits them through hard wiring to the transmission control unit (TCU). SmartShift is a true shift-by-wire system.

SmartShift offers two main advantages over conventional transmission control devices. Without a floor-mounted shift control, usable cab space is increased. The SmartShift control is operated by the fingers of the driver's right hand, allowing both hands to remain on the steering wheel.

A two-position driving mode slide switch is mounted on the body of the control lever just before the paddle widens out. The slide switch allows the driver to choose automatic (AUTO) or manual (MAN) mode. See [Fig. 14.1](#).

In AUTO mode, gears shift automatically without driver interaction. Manual gearshifts are accomplished by a momentary pull or push on the control in the plane perpendicular to the steering wheel. Pull upward (toward the driver) on the control to upshift and push downward (away from the driver) to downshift. The control is spring-loaded and returns to its rest position when released after an upshift or downshift.

A four-position (R, N, D, L) gear selector switch is located at the end of the lever. See [Fig. 14.1](#).

A small neutral lock button is embedded in the gear selector switch to prevent accidental shifts into gear from neutral. Any time you shift through neutral, press down on the neutral lock button to move the switch from neutral (N) to another gear, such as drive (D), low (L), or reverse (R). When shifting to neutral, it is not necessary to press the neutral lock button.

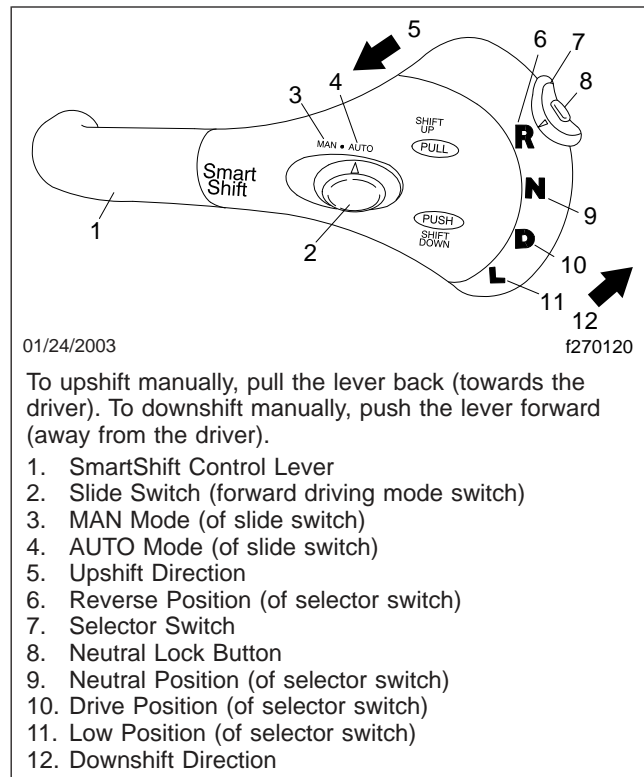

Fig. 14.1, SmartShift Control (with Eaton Fuller UltraShift, UltraShift PLUS, and AutoShift)

Eaton Fuller UltraShift DM Automated Transmissions

General Information, Ultrashift Transmissions

Eaton Fuller UltraShift is a heavy-duty fully automated transmission. No clutch pedal is required to operate the vehicle. The UltraShift uses a dry clutch system which is offered only on this automated transmission system.

The UltraShift transmission uses the four-position SmartShift control lever on the steering column to select gears. The current gear is displayed on the indicator on the right-hand control panel. All forward shifts can be made either manually or automatically.

Automated and Automatic Transmissions

Operation, UltraShift Transmissions Automatic and Manual Modes

The SmartShift control lever has a slide switch located on the body of the control lever just before the paddle widens out. See [Fig. 14.2](#). The slide switch controls the forward driving mode, automatic (AUTO) or manual (MAN).

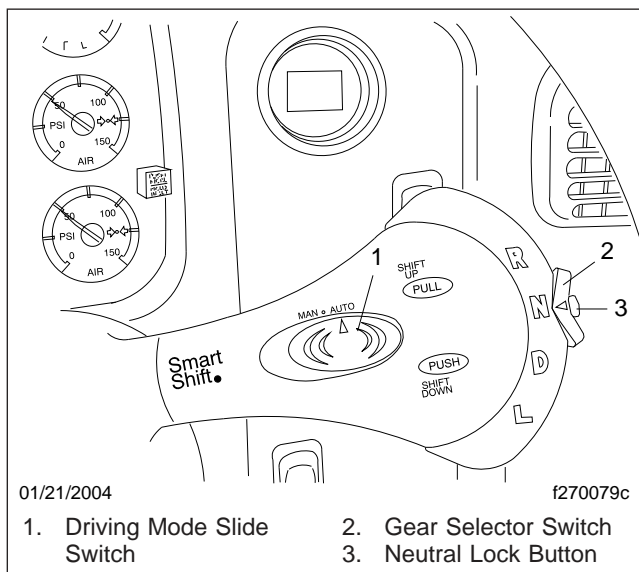

Fig. 14.2, Shift Controls and Indicators, UltraShift and AutoShift Transmissions

To change mode at any time, move the slide switch in the desired direction. This allows the driver to respond to a wide range of driving conditions, such as blind corners, tight curves, and steep hills.

IMPORTANT: In either mode, it is possible to shift manually by moving the lever up or down as needed. When the engine speed is within 75 rpm of the load-based shift point for an automatic shift, the TCU will advance the shift.

In either mode, the gear indicator displays the current gear. See [Fig. 14.3](#).

At the start of a shift, the current gear continues to display until the transmission has been pulled into neutral. As the transmission is synchronizing for the new (target) gear, the gear indicator flashes the number of the target gear.

When the shift is complete, the gear indicator displays the new gear, without flashing.

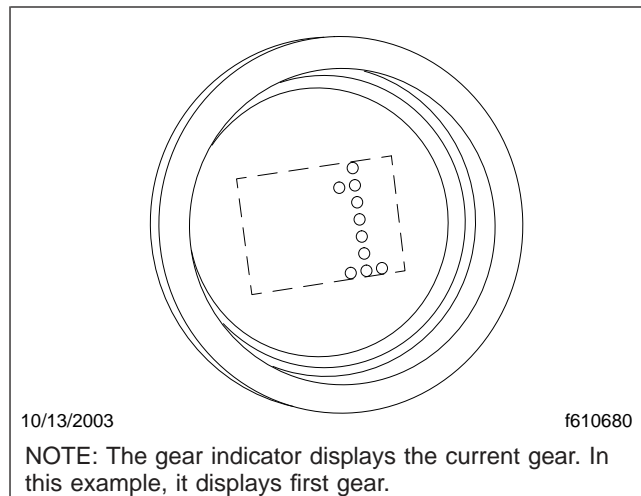

Fig. 14.3, Gear Indicator: Current Gear

Automatic Mode (AUTO)

In automatic drive mode (AUTO), upshifts and downshifts are made by the transmission without driver intervention. Press the neutral lock button, move the gear selector switch to drive (D), and press down on the throttle pedal. The transmission will shift automatically.

If driving conditions require, it is still possible to request a manual shift. The transmission will make the shift if the engine speed is within 75 rpm of the load-based shift point for that gear.

If the driver presses down on the throttle pedal after a manual downshift in automatic mode, the transmission will upshift again if the TCU requires it.

Manual Mode (MAN)

In manual drive mode (MAN), upshifts and downshifts are made by the driver.

- To upshift, pull the lever up (towards the driver).
- To downshift, push the lever down (away from the driver).

The system will hold the current gear until the driver requests a shift. In downhill situations in particular, the driver must be alert to vehicle speed by downshifting and/or using the service brakes as needed.

A shift request will be refused if the selected gear would cause engine overspeed or excessive lugging.

Automated and Automatic Transmissions

Power Up

1. With the parking brake set, select neutral (N) by moving the gear selector switch to the N position.
2. Turn on the ignition switch. The CHECK TRANS and TRANS TEMP lamps illuminate and go out again (bulb check).

The current gear indicator shows the dot display, arranged in a square pattern. All dots in the pattern should light up, without gaps or spaces. See [Fig. 14.4](#).

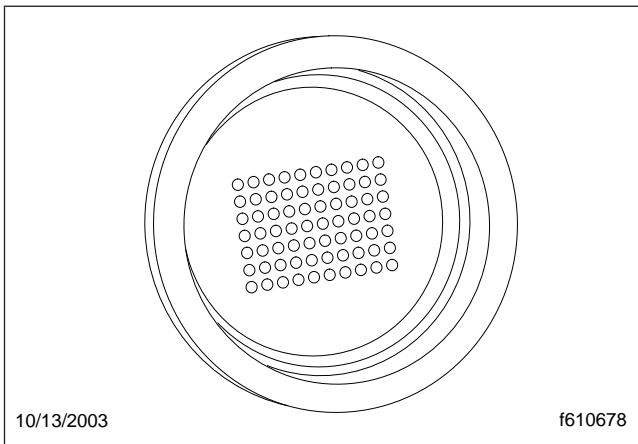

Fig. 14.4, Gear Indicator: Power Up Dot Display

3. Wait for the current gear indicator to show a solid N. See [Fig. 14.5](#). When the N is solid (not flashing), the TCU is powered up. Apply the service brake and start the engine.

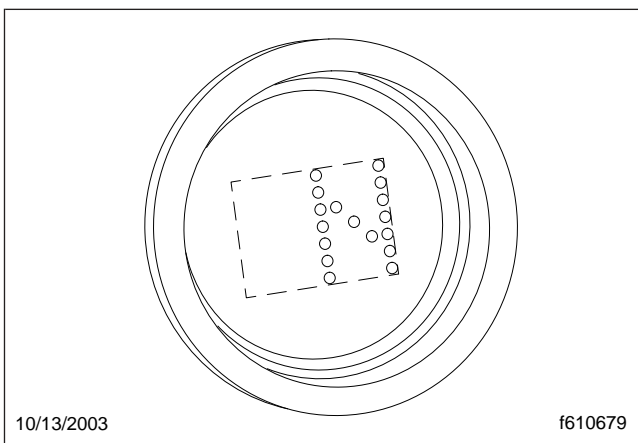

Fig. 14.5, Gear Indicator: Neutral

4. Press the neutral lock button and move the gear selector switch downward to the D position below neutral. The gear is displayed on the current gear indicator.

NOTE: When D is selected, the TCU starts up in second gear. If desired, the driver can select to start up in first. No other start gear is available.

5. On a level grade, release the parking and service brakes and press down on the throttle pedal to allow the vehicle to move forward. The vehicle will not move until the pedal is depressed.

WARNING

When starting or stopping on hills and grades, use extra care to prevent the vehicle from rolling back. A rollback accident could cause death, serious personal injury, or property damage.

6. Prevent the vehicle from rolling backwards when stopped on a hill or grade, or when the vehicle is starting from a stop on a hill or grade.
 - 6.1 *To start from a full stop on a hill or grade, quickly move your foot from the brake pedal and press firmly on the throttle pedal.*

On steep hills, set the parking brake, and release it only when there is enough engine power to prevent rollback.
 - 6.2 *To stop on a hill or grade, press and hold the brake pedal to keep the vehicle from moving.*

On steep hills, set the parking brake. When parking, chock the tires, front and/or rear.

NOTICE

Never hold a hill with the throttle pedal. Operating the vehicle too long between engine idle and 1000 revolutions per minute (rpm) during takeoff will cause the clutch to overheat.

Power Down

1. Apply the service brakes.

Automated and Automatic Transmissions

2. Move the gear selector switch to the N position. When the N on the current gear indicator is solid (not flashing), the TCU is ready to power down.
3. Set the parking brake.
4. Turn off the ignition key and shut down the engine.

Selecting Gears

Neutral

IMPORTANT: Always start the engine with the transmission in neutral (N), the parking brake set, and the service brakes applied.

N is located directly below R on the four-position gear selector switch on the SmartShift control lever. To select N, move the gear selector switch to the position below R. When neutral is selected, the letter N displays on the current gear indicator. See [Fig. 14.5](#).



Do not coast in neutral. Coasting in neutral can cause an accident, possibly resulting in severe personal injury or death.

Neutral is always available during operation, whatever the vehicle speed. When in neutral, requests to upshift or downshift are ignored. If the gear selector switch is moved from N to D while the vehicle is moving, the transmission will shift into a gear within the engine's operating speed range.

When shifting from neutral, always press on the brake pedal. If the brake pedal is not pressed, the transmission will not shift, the current gear display will flash N, and an audible alert will sound. To reset the transmission, return the gear selector switch on the SmartShift lever to N and attempt the shift again, this time with the brake pedal pressed.

Before shutting down the engine, return the gear selector switch to N. When the ignition is turned off, the transmission will reset to neutral in a few minutes regardless of the position of the gear selector switch.

Drive

Drive (D) is located directly below N on the four-position gear selector switch on the SmartShift control lever. To select D, press in the neutral lock button and move the gear selector switch to the position below N. When D is selected, the number of the cur-

rently selected forward gear displays on the gear indicator. See [Fig. 14.3](#).

When in drive, requests to upshift or downshift are enabled. Either manual or automatic mode can be selected on the slide switch.

The default starting gear is second, but first can be selected by the driver, if desired. To change the starting gear, press the brake pedal and select D with the vehicle stopped. The current gear indicator will display the starting gear. Move the control lever up or down until the desired starting gear is displayed.

The TCU adapts to the working conditions of each vehicle and its driver. After power up or a load change, it needs to learn the new conditions. While learning, it may hold a gear too long before upshifting. Start the upshift manually. It may take three or four shifts before UltraShift succeeds in learning the new load-based shift points, but after that it will handle the shifting automatically.

Reverse

Reverse (R) is located at the upper end of the four-position gear selector switch on the SmartShift control lever. To select R, press in the neutral lock button and move the gear selector switch upward to the position above neutral.

The UltraShift transmission has two reverse gears: reverse low (RL) and reverse high (RH). To shift manually between them, use the control lever as described for MAN mode. There is no AUTO mode for reverse.

When reverse low is selected, the letter R displays on the current gear indicator. When reverse high is selected, the letter H displays on the current gear indicator. See [Fig. 14.6](#).

IMPORTANT: Under normal conditions, do not select reverse with the vehicle moving forward.

The vehicle must be moving at less than two miles per hour (3 km/h) before selecting reverse. If reverse is selected when the vehicle is moving faster, an audible alert will sound and continue sounding at three-second intervals until the gear selector switch is returned to the D position or the vehicle slows to the proper speed.

If necessary to rock the vehicle, use the gear selector switch to shift back and forth at low speed between reverse and drive.

Automated and Automatic Transmissions

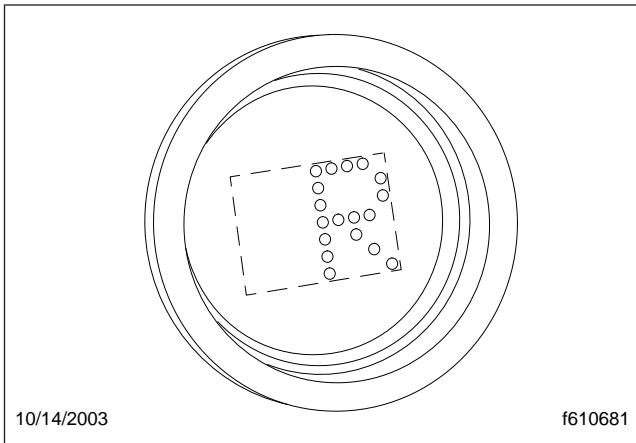

Fig. 14.6, Gear Indicator: Reverse Low Gear

Low

Low (L) is located at the lower end of the four-position gear selector switch on the SmartShift control lever. To select L, press in the neutral lock button and move the gear selector switch to the position below D.

When in low, the current gear is maintained. Requests to upshift are not enabled.

IMPORTANT: If the engine is approaching overspeed, the TCU will override the current gear setting and upshift to prevent engine damage.

To enhance engine braking, downshifts are performed at higher rpm than normal.

If L is selected from neutral while stopped, the vehicle starts up in first gear and stays there until the engine approaches overspeed.

Upshifting

To request an upshift with the transmission in drive, pull the control lever up (towards the driver). If the gear is available, the transmission will upshift and the new gear will display on the gear indicator. Skip shifts are not available while upshifting. Upshifts are not available in low, except to prevent engine overspeed.

If the transmission does not upshift quickly enough after power up or a load change, begin the shift manually. The TCU will learn the new load-based shift conditions after three or four shifts.

If the gear requested is unavailable, a tone will sound. An unavailable request to upshift is not stored in memory; the upshift must be requested again.

Downshifting

To request a downshift with the transmission in drive or low, push the control lever down (away from the driver). If the gear is available, the transmission will downshift and the new gear will display on the gear indicator. Skip shifts are available while downshifting.

For best engine braking, select low while moving. In low, downshifts are performed at higher rpm than in drive.

IMPORTANT: If the engine is approaching overspeed, the TCU will override the current gear setting and upshift to prevent engine damage.

If the gear requested is unavailable, a tone will sound. An unavailable request to downshift is not stored in memory; the downshift must be requested again.

When coasting to a stop, the TCU may not finish the downshift until the driver presses down on the throttle pedal again.

IMPORTANT: A downshift request can never result in a shift into neutral, even if the vehicle is in the drive position in the lowest possible gear.

Before starting down a hill, slow down. Downshift to a speed that you can control without hard pressure on the service brakes.

Before entering a curve, slow down to a safe speed. Downshift if necessary. This lets you use some power through the curve to help the vehicle be more stable on the turn. It also allows you to regain speed faster as you come out of the curve.

Ultrashift Diagnostics

Clutch Protection Fault

Even though a vehicle with an UltraShift transmission does not have a clutch pedal, it does have a mechanical clutch. As you slowly increase and decrease engine rpm from a stop, the mechanical clutch is engaging and disengaging, just like slipping the clutch with a manual transmission. Excessive clutch slippage creates heat and reduces the life of the clutch. These are some conditions which can cause clutch damage:

Automated and Automatic Transmissions

- Using the throttle to hold the vehicle on a hill
- Starting the vehicle from a stop in a gear that's too high
- Overloading the vehicle
- Using high idle with the vehicle in gear

The TCU is programmed to prevent clutch damage. When the clutch overheats, the following alerts take place:

- The TRANS TEMP light comes on
- The current gear indicator displays "C," then "A"
- A warning tone sounds at one-second intervals

The alerts continue until the clutch cools, the throttle is released, or the clutch is fully engaged.

System Problem

In the event of a problem, complete the following steps.

1. Note the driving conditions at the time the problem occurred.
2. Record the status of the transmission at the time of the problem (AUTO or MAN mode, gear setting, current gear, engine speed, etc.).
3. Complete the transmission reset procedure.

Transmission Reset Procedure

In some cases, proper transmission operation can be restored by resetting the TCU. Use the following procedure to reset the TCU.

1. When it is safe to do so, stop the vehicle.
2. Select N by moving the gear selector switch to N.
3. Set the parking brake.
4. Shut down the engine.
5. Wait at least two minutes.
6. Restart the engine.
7. If the problem continues or the transmission doesn't achieve neutral after power up, contact an authorized Freightliner or Eaton service facility.

Locked In Gear

If the vehicle is shut down in gear, the transmission may become locked in gear. The transmission will attempt to get to neutral during the next power up if the gear selector switch is positioned on N. If neutral can't be achieved, a dash (–) will appear on the gear indicator when the vehicle is restarted.

NOTE: If the transmission becomes locked in gear while the vehicle is moving, increased braking effort may be required to stop the vehicle.

If the current gear indicator displays a dash during power up with the gear selector switch in neutral, complete the following steps.

1. Make sure the parking brake is set.
2. Turn off the ignition and wait at least two minutes.
3. Depress the brake pedal and release the parking brake.
4. Make sure the gear selector switch is positioned on N, then turn on the ignition key. Do not attempt to start the engine yet.
5. If necessary to get the transmission to shift into neutral, release the pressure on the brake pedal slightly.
6. Once the TCU reaches neutral, a solid N will appear on the gear indicator and the vehicle will start. Apply the service brakes and start the engine.
7. If the current gear indicator continues to display a dash, contact an authorized Freightliner or Eaton service facility.

Eaton Fuller UltraShift PLUS Automated Transmissions

Eaton Fuller UltraShift PLUS automated transmissions use shift selection software and electric clutch actuation; a clutch pedal is not needed to operate the vehicle. These transmissions use the four-position SmartShift control (see [Fig. 14.1](#)) on the steering column to select mode, direction, neutral, low, and to make manual shifts. To know what gear the transmission is in, see the current gear indicator on the dash. Forward shifts can be made either manually or automatically.

Automated and Automatic Transmissions

Power Up

NOTE: Engine cranking is delayed until the transmission power-up is complete and the gear display shows a solid "N".

1. With the parking brake set, turn the ignition switch to the ON position.
2. Start the engine.
3. Apply the service brake.

NOTE: If the service brake is not applied while selecting a starting gear, the initial start gear will not be found and the driver will need to select Neutral and press the service brake while selecting the desired mode.

4. Select the desired mode and starting gear. (Inappropriate start gear selections are ignored to avoid damaging the transmission.)
5. Release the parking brake.
6. Release the service brake and apply the accelerator.

Power Down

1. Select Neutral on the shift control.

NOTE: If the gear display does not show a solid "N", neutral has not yet been obtained. Neutral should always be reached before powering down an UltraShift PLUS, except in cases of emergency.

2. Set the parking brake.
3. Turn off the ignition, and shut down the engine.

Reverse (R)

NOTE: If attempting to select a non-Neutral mode without applying the service brakes, the transmission will not shift into gear. To shift into gear, select Neutral, apply the service brakes, and select the desired mode again. Also, the vehicle will not engage reverse above 2 mph (3 km/h).

Reverse (R) is at the upper end of the four-position selector switch located at the end of the SmartShift control. To select R, press in the neutral lock button

and move the selector switch to the position above neutral. The default Reverse gear is engaged.

NOTICE

Avoid launching the vehicle in high range. Launching the vehicle in high range increases the likelihood of clutch abuse and could be detrimental to clutch life.

Automatic Mode (AUTO)

In automatic drive mode (AUTO), upshifts and downshifts are made by the UltraShift PLUS without driver intervention. Press in the neutral lock button, move the selector switch to Drive (D), and press down on the throttle pedal. The transmission will shift automatically.

NOTE: If attempting to select a non-Neutral mode without applying the service brakes, the transmission will not shift into gear. To shift into gear, select Neutral, apply the service brakes, and select the desired mode again.

In Drive, the start gear is automatically selected. The selected start gear can vary depending on several vehicle inputs such as load, grade, and axle/transmission ratio. The start gear can be changed using the SmartShift control, provided the selected gear would allow the vehicle to launch without damaging the transmission. If the start gear is changed using the SmartShift control, it will be the default until the vehicle is powered down or the selection is changed again manually.

IMPORTANT: Prior to ascending a steep grade, either reduce the default start gear by one (using the SmartShift control) or apply full throttle for the duration of the grade so the vehicle maintains the proper engine and vehicle speed during the entire grade.

In Drive, the transmission automatically performs upshifts and downshifts. However, when the transmission is near the shift point, the shift can be forced using the upshift or downshift function of the SmartShift control.

NOTE: The transmission may deny a shift while ascending or descending a grade if the load of the vehicle and grade of the terrain in combination with the drivetrain ratio and engine torque

Automated and Automatic Transmissions

fall outside of the acceptable range to perform a shift. If the shift is denied, a tone will sound.

Manual Mode (MAN)

In manual mode (MAN), the driver selects upshifts and downshifts instead of letting the UltraShift PLUS select them automatically. Manual shifting may be helpful when traversing a work site, railroad tracks, or steep grades, for example. To drive forward, press in the neutral lock button, move the selector switch to Drive (D), and press down on the throttle pedal. To shift up, pull the lever up (towards you); to shift down, push the lever down (away from you). The system holds the current gear unless a shift is requested or if the system initiates a manual mode override.

NOTE: The transmission may deny a shift while ascending or descending a grade if the load of the vehicle and grade of the terrain in combination with the drivetrain ratio and engine torque fall outside of the acceptable range to perform a shift. If the shift is denied, a tone will sound.

NOTE: If attempting to select a non-Neutral mode without applying the service brakes, the transmission will not shift into gear. To shift into gear, select Neutral, apply the service brakes, and select the desired mode again.

Manual Mode Override

The system is equipped with a manual mode override function. If the vehicle is being "back driven" (for example, descending a grade and vehicle speed exceeds engine speed) and the engine speed is excessively high, the system will upshift automatically. Also, if the start gear is changed and it causes the engine to lug at takeoff, the system will override the current position and select the best available gear.

Low (L)

Low (L) is at the lower end of the four-position selector switch located at the end of the SmartShift control. Use Low when wanting to maximize engine braking and minimize the use of the brake pedal—for example, when driving down long grades or when coming to a stop. To select Low, press in the neutral lock button and move the selector switch to the L position. The lowest available start gear will be selected (the starting gear cannot be changed in Low).

If Low is selected while moving, the transmission will not upshift (unless the system initiates a Low override). The system will downshift at the earliest opportunity to provide maximum engine braking.

NOTE: If attempting to select a non-Neutral mode without applying the service brakes, the transmission will not shift into gear. To shift into gear, select Neutral, apply the service brakes, and select the desired mode again.

Low Override

The system is equipped with a Low override function. If the vehicle is being "back driven" (for example, descending a grade and vehicle speed exceeds engine speed) and the engine speed is excessively high, the system will upshift automatically. Also, if the start gear is changed and it causes the engine to lug at takeoff, the system will override the current position and upshift.

Clutch Abuse Protection

Although a vehicle equipped with an UltraShift PLUS uses an automated clutch, the clutch can still overheat and slip with improper use. The clutch abuse protection feature helps protect the clutch if the automated clutch starts to overheat. When the clutch abuse protection feature initiates and sounds a warning tone, full clutch actuation must be completed quickly. If it is not completed quickly enough, the system will either open the clutch (if the throttle pedal is not being pressed) or close the clutch (if the throttle pedal is being pressed). If the abuse continues, the system will open the clutch and take away throttle control briefly to allow the clutch to cool down.

To protect the clutch:

- Select the lowest possible start gear for the application.
- Use Creep Mode when appropriate.
- Use the service brakes and the Hill Start Aid when launching on a grade.
- Minimize the time it takes to engage the clutch from rest.
- Do not use the throttle to hold the vehicle on a grade; use the service brakes.

Automated and Automatic Transmissions

- Do not use the throttle to stop roll back on an incline after Hill Start Aid disengages; use the service brakes, and then relaunch.
- Do not continually start and stop, especially when loaded; use a lower gear or Creep Mode.

Creep Mode

The Creep Mode function allows the vehicle to maintain a constant speed at engine idle without the driver holding the throttle pedal position. This mode is useful for very low-speed maneuvering and applications where steady vehicle speed is required. The vehicle speed is determined by the selected gear ratio operating at governed low engine idle speed. Any available gear may be selected, though the transmission will downshift or exit Creep Mode to prevent stalling if the engine lugs due to load conditions.

By default, Creep Mode can be activated while in Manual Mode or Low. Eaton's ServiceRanger diagnostic software can be used to enable Creep Mode in Automatic Mode and/or Reverse.

Engaging Creep Mode

To engage Creep Mode:

1. Select Low or Manual Mode and the desired gear (while stopped or moving).
2. Apply the throttle pedal to accelerate the vehicle until the clutch is closed (engaged).
3. Release the throttle pedal. The vehicle will continue moving at governed low engine idle speed.

Exiting Creep Mode

To exit Creep Mode, apply the throttle pedal to accelerate temporarily, or select a higher gear in Manual Mode. (Creep Mode can be resumed in the selected gear by releasing the throttle pedal.)

NOTE: The transmission will exit Creep Mode if the engine lugs 150 rpm below the governed low engine idle speed. In this case, a lower gear should be selected if available.

Hill Start Aid

UltraShift PLUS transmissions are equipped with a Hill Start Aid (HSA) feature to prevent the vehicle from rolling while on grades steeper than 3% and

allow for a controlled launch. A grade sensor is used to determine when to engage the feature.

HSA is "on" by default. It can be turned off by pressing and releasing the override switch on the dash. HSA will turn back on after the first successful launch.

When the vehicle is stopped on a grade greater than 3% and in a forward mode or reverse, depress the service brakes then release them. The vehicle will begin to move after 3 seconds, and the clutch will perform partial engagements to slow the vehicle motion. Either step on the brake or apply the throttle to continue negotiating the grade.

Engine Overspeed Protection

The system will upshift if necessary to prevent engine overspeed in Drive, Manual, and Low.

Shuttle Shifting

Shuttle shifting from reverse to any forward mode is only allowed if the vehicle speed is approximately zero.

Auto Start Gear Selection and Override

The UltraShift PLUS system uses various inputs to automatically select the best start gear in Drive and Manual. This selection can be changed using the SmartShift control; however, if the selection requested could cause damage or engine lugging, the request will be denied and a tone will sound.

Skip Shifting

When appropriate, the UltraShift PLUS system may skip shift in Drive. When prevailing conditions like load and grade allow, skip shifts can be performed in Manual mode using the SmartShift control.

Auto Neutral

The UltraShift PLUS system will automatically shift to neutral if the vehicle is left in Drive and the parking brake is set. "AN" will show on the gear display. To re-engage the transmission, select Neutral and then either Drive or Reverse on the shift control (it will re-engage regardless of whether the parking brake is released).

Automated and Automatic Transmissions

Automatic Traction Control

The UltraShift PLUS system requires the Automatic Traction Control (ATC) option to be enabled when driving in soft soil/sand to prevent wheel slippage and shifting issues. The ATC system has two modes: "normal" (for sand and loose road surface) and a mud/snow setting.

ATC Normal Mode

In normal mode, the system will engage the brakes on the wheel or side that the wheel slip is occurring to help the vehicle gain traction. The point at which the traction control will actuate the braking system increases with throttle: low throttle allows the system to brake the wheels earlier; heavy/full throttle raises the point of the acceptable wheel slip.

Adhere to the following points when driving in ATC normal mode:

- If using Automatic mode in soft soil and/or sand, maintain the engine speed between 1000 and 1300 rpm to prevent unnecessary upshifting.
- If using Manual mode in soft soil and/or sand, do not attempt an upshift and try to maintain the current gear.
- If the vehicle comes to a stop in the sand it may be necessary to back up prior to attempting forward movement.

ATC Mud/Snow Mode

To select the mud/snow mode, depress the ATC switch. This mode raises the wheel slip speed that is allowed before the traction control activates. The point at which the traction control will actuate the braking system increases with throttle: low throttle allows the system to brake the wheels earlier; heavy/full throttle raises the point of the acceptable wheel slip.

Load-Based Shifting

The UltraShift PLUS system is adaptive and will change the shift points based on grade, engine RPM, throttle position, and vehicle load. After changing loads or powering up, the system needs to relearn these inputs for the first few shifts to make the proper adjustments.

Coasting

When coasting to a stop on level terrain, the UltraShift PLUS system may not downshift into the lower gears. It will select a gear after the throttle is applied.

Eaton Fuller AutoShift Automated Transmissions

Refer to the Eaton website for additional information, www.roadranger.com.

General Information, AutoShift Transmissions

Eaton Fuller AutoShift transmissions have ten or eighteen forward speeds and two reverse speeds. The driver must use the clutch to start and stop the vehicle. However, the driver does not need to use the clutch to shift gears. The transmission signals the engine controller when to break torque and the engine controller automatically increases or decreases engine speed. When engine speed is correct, the transmission engages the next gear and signals the engine controller to resume operation.

Operation, AutoShift Transmissions

Automatic and Manual Modes

The SmartShift control lever has a slide switch located on the body of the control lever just before the paddle widens out. See [Fig. 14.2](#). The slide switch controls the forward driving mode, automatic (AUTO) or manual (MAN).

To change mode at any time, move the slide switch in the desired direction. This allows the driver to respond to a wide range of driving conditions, such as blind corners, tight curves, and steep hills.

In either mode, the gear indicator displays the current gear. See [Fig. 14.3](#).

At the start of a shift, the current gear continues to display until the transmission has been pulled into neutral. As the transmission is synchronizing for the new (target) gear, the gear indicator flashes the number of the target gear.

When the shift is complete, the gear indicator displays the new gear, without flashing.

Automated and Automatic Transmissions

Automatic Mode

In automatic drive mode, upshifts and downshifts require no driver interaction. Press in the neutral lock button, move the gear selector switch to drive (D), depress the clutch to engage the gear selected, release the clutch, and press down on the throttle pedal. The transmission will shift automatically based on vehicle and transmission conditions.

If the vehicle is stopped while in drive, pull up or push down on the SmartShift control lever to change the starting gear.

If driving conditions require, it is possible to request a manual shift. The transmission will make the shift if the engine speed is within 75 rpm of the load-based shift point for that gear.

Manual Mode

In manual drive mode (MAN), upshifts and downshifts are made by the driver. Manual mode should be used whenever you want to select the shifts instead of letting the transmission shift automatically.

To upshift, pull the lever up (towards the driver). To downshift, push the lever down (away from the driver). The system will hold the current gear until the driver requests a shift. In downhill situations in particular, the driver must be alert to vehicle speed by downshifting and/or using the service brakes as needed.

A shift request will be refused if the selected gear would cause engine overspeed or excessive lugging.

If the vehicle is stopped while in drive, pull up or push down on the SmartShift control lever to change the starting gear.

Power Up

1. With the parking brake set, select neutral (N) by moving the gear selector switch to the N position.
2. Depress the clutch pedal all the way down to the floor.
3. Start the engine. The CHECK TRANS and TRANS TEMP lamps illuminate and go out again (bulb check).
4. Release the clutch to allow the speed sensor on the input shaft to get a reading.

5. Depress the clutch again and release the parking and service brakes.
6. Select the desired starting gear.
7. Release the clutch.

Selecting a Starting Gear

1. In automatic mode, select drive (D) by sliding the gear selector switch downward to the next position below the neutral position.
2. Depress the clutch to engage the gear selected. Release the clutch and drive the vehicle.

Changing the Default Starting Gear

To select a starting gear other than the default starting gear, follow the instructions below.

1. Make sure the vehicle is stopped and in drive.
2. In either automatic or manual mode, pull upward (to increase) or push downward (to decrease) on the SmartShift control lever. Each pull upward on the control increases the starting gear by one gear, but no higher than fourth gear.
3. The number of the gear selected will flash on the gear indicator until the driver releases the clutch. This gear will be stored in memory as the default starting gear until either a different starting gear is selected by the driver or the engine is shut down.

NOTE: The transmission may also be programmed so that it is not possible to select a starting gear other than the preprogrammed default starting gear.

Upshifting

NOTE: With the transmission in drive in the automatic mode, upshifts require no driver interaction.

1. With the transmission in drive in the manual mode, pull the control lever up (towards the driver) to upshift. If the requested gear is available, the transmission will upshift and the new gear will display on the gear indicator.

NOTE: Two consecutive, momentary upward pulls will cause a skip shift when the next two higher gears are available and conditions are appropriate.

Automated and Automatic Transmissions

2. To skip shift, move the control twice in less than ½-second. The number of the gear engaged will appear on the gear indicator.

NOTE: The Eaton Fuller AutoShift transmission is able to perform triple upshifts when the next three higher gears are available and conditions are appropriate. To triple-shift, move the control three times in less than ½-second.

If the gear requested is unavailable, a tone will sound. An unavailable requested upshift is not stored in memory; the upshift must be requested again.

Downshifting

NOTE: With the transmission in drive in the automatic mode, downshifts require no driver interaction.

1. With the transmission in drive in the manual mode, push the control lever down (away from the driver) to downshift. If the requested gear is available, the transmission will downshift.

NOTE: Two consecutive, momentary downward pushes will cause a skip shift, when the next two lower gears are available and conditions are appropriate.

2. To skip shift, move the control lever two times in less than ½-second. The number of the gear engaged will appear on the gear indicator.

NOTE: The Eaton Fuller AutoShift transmission is able to perform triple downshifts when the next three lower gears are available and conditions are appropriate. To triple shift, move the control lever three times in less than ½-second.

If the gear requested is unavailable, a tone will sound. An unavailable requested downshift is stored in memory and the shift will be made when the gear is available. The time limit for this memory is a programmable parameter.

Neutral

Select neutral by sliding the gear selector switch to the N position.

N is located directly below R on the four-position gear selector switch on the SmartShift control lever.

To select N, move the gear selector switch to the position below R. When neutral is selected, the letter N displays on the current gear indicator. See [Fig. 14.5](#).

NOTE: Neutral is always available during operation. When in neutral, upshift and downshift requests are ignored. If the gear selector switch is moved from neutral (N) to drive (D) while the vehicle is moving, the transmission will shift into the gear that is appropriate for the road speed of the vehicle.

Drive

Drive (D) is located directly below N on the four-position gear selector switch on the SmartShift control lever. To select D, press the neutral lock button and move the gear selector switch to the position below N. When D is selected, the number of the currently selected forward gear displays on the gear indicator. See [Fig. 14.3](#).

When in drive, requests to upshift or downshift are enabled. Either manual or automatic mode can be selected on the slide switch.

Reverse

Reverse (R) is located at the upper end of the four-position gear selector switch on the SmartShift control lever. To select R, press the neutral lock button and move the gear selector switch upward to the position above neutral and depress the clutch pedal.

NOTE: AutoShift transmissions have a dual-range reverse. Reverse low (RL) is the default reverse gear.

Select reverse high (RH) by pulling upward on the SmartShift control lever. When reverse low is selected, the letter R displays on the current gear indicator. When reverse high is selected, the letter H displays on the current gear indicator. See [Fig. 14.6](#).

NOTE: Reverse may be engaged below a programmable forward speed in order to rock the vehicle. If reverse is selected above the programmed forward speed, an audible warning will sound indicating that the gear is not available.

Low Gear Operation

Use low (L) to maximize engine braking and minimize the use of the brake pedal. It is most useful when descending steep hills or when coming to a stop. Engine speed will be increased by 200 rpm and

Automated and Automatic Transmissions

shift points will be offset by 200 rpm. The efficiency of the exhaust brake will be maximized.

Low (L) is located at the lower end of the four-position gear selector switch on the SmartShift control lever. To select L, press the neutral lock button and move the gear selector switch to the position below D.

Allison Automatic Transmissions

Refer to the Allison website for additional information, www.allisontransmission.com.

General Information, Allison Transmissions

HD-series automatic transmissions have six forward speeds and one reverse speed. These transmissions have electronic shift controls that can be programmed to allow the use of different numbers of geared speeds. For instance, the transmission can be programmed to operate as a 4-speed, 5-speed, or 6-speed unit in the "primary" shift mode. If needed, a "secondary" shift mode can be programmed to provide another shift configuration to optimize vehicle use under different operating conditions. To activate a secondary shift mode, or other special functions programmed into the electronic control unit (ECU), depress the Mode button. See Fig. 14.7. "Mode On" is displayed in the indicator panel just above the push buttons. A label just above the Mode button identifies the special function.

NOTE: Each time a push button is depressed on the shift selector, a short beep will be heard. This indicates that the ECU has received input to change operation.

Operation Tips, Allison Transmissions

WARNING

Never shift from neutral (N) to drive (D) or reverse (R) at engine speeds above idle. The vehicle will lurch forward or backward, which could cause property damage and personal injury.

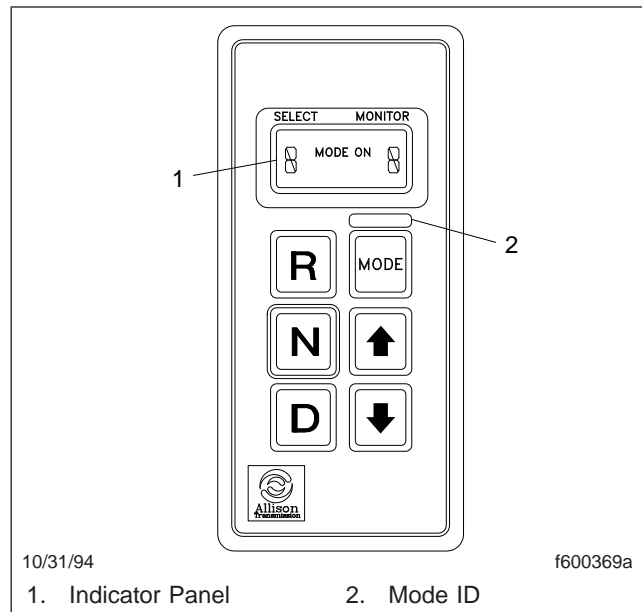

Fig. 14.7, Allison Push Button Shift Selector

NOTICE

The engine should never be operated for more than thirty seconds at full throttle with the transmission in gear and the output stalled. Prolonged operation of this type will overheat the transmission fluid and will result in severe damage to the transmission.

NOTICE

Do not allow the vehicle to coast in neutral. This can result in severe transmission damage. Also, no engine braking is available.

The following tips highlight important operation principles.

- Start the engine, then check the digital display on the shift selector. Under "Select" at the top of the unit, the display should always show the "primary" shift mode. Under "Monitor," the current gear should be displayed.
- Use reverse (R) to back the vehicle. Completely stop the vehicle before shifting from a forward gear to reverse, or from reverse to forward. There is only one reverse gear.

Automated and Automatic Transmissions

- Select drive (D) for all normal driving conditions. The vehicle will start out in 1st gear, and as speed increases, the transmission will upshift through each gear automatically. As the vehicle slows down, the transmission will downshift to the correct gear automatically.
- The pressure of your foot on the accelerator pedal influences the automatic shifting. When the pedal is fully depressed, the transmission will automatically upshift near the governed speed of the engine. A partially-depressed position of the pedal will cause the upshifts to occur at a lower engine speed.
- Occasionally the road, load, or traffic conditions make it desirable to restrict the automatic shifting to a lower range. The lower the gear range, the greater the engine braking power.
- Use the up or down arrow buttons on the shift selector to reach the desired gear. The "Select" indicator will display your choice, and the "Monitor" indicator will show the selected gear once it is reached. In the lower gear ranges, the transmission will not upshift above the highest gear selected unless the engine governed speed is exceeded.
- Use neutral and apply the parking brake when the vehicle is parked with the engine running.

15

Drive Axles

Differential Lock, Drive Axles	15.1
Interaxle Lock, Tandem and Tridem Axles	15.2

Drive Axles

Differential Lock, Drive Axles

The driver-controlled differential lock feature (side-to-side wheel lock, traction control, or traction equalizer) is available on vehicles with single- or tandem-drive axles.

The differential lock provides maximum traction for slippery conditions by forcing the wheels on each drive axle governed by the switch to rotate together. When the differential lock is engaged, the clutch collar completely locks the differential case, gearing, and axle shafts together, maximizing the traction of both wheels.

Differential Lock Switch

See **Fig. 15.1** for the differential lock switch on a vehicle with a single drive axle.

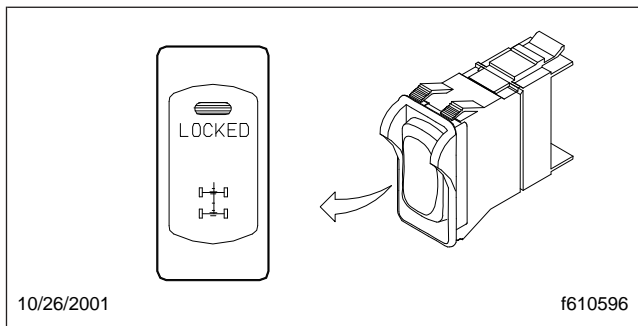

Fig. 15.1, Differential Lock on Single Drive Axle

For a vehicle with tandem axles, there are several differential lock options available:

- one switch to control the differential lock on only one of the drive axles (this switch will show only one dot on one drive axle, varying slightly from the switch shown in **Fig. 15.2**).
- one switch to control the differential locks on both drive axles (**Fig. 15.2**).
- two switches, each of which controls the differential lock on one drive axle.

When the differential lock switch is pressed, three responses are possible:

- **Normal Response:** The LED in the switch blinks until the differential lock is engaged. At this point, the LED illuminates steadily. In normal operation, the wheels may lock so quickly

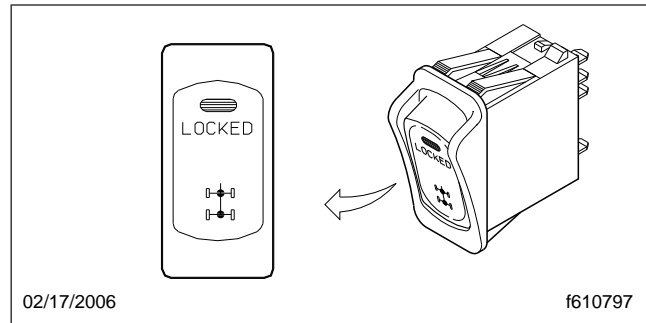

Fig. 15.2, Differential Lock on Both Axles

that the blinking of the LED is barely noticeable.

If engagement of the differential lock mechanism is not possible for any reason (ignition is turned off, vehicle is moving faster than 25 mph, etc.), the LED will stop blinking and turn off.

- **Slow Response:** If engagement of the differential lock mechanism is slowed for any reason (vehicle moving too fast, low air pressure, etc.), the LED will continue to blink until the wheels are able to lock. As in the normal response, the LED illuminates steadily once the wheels have locked.
- **Abnormal Response:** If the LED blinks for more than 30 seconds, the lock mechanism may not be fully engaged/disengaged. Bring the vehicle to an authorized Freightliner service facility for testing.

Differential Lock Operation

NOTE: On some vehicles, the differential lock system is connected through the low speed range of the transmission. If this system is used, the transmission must be in the low speed range for the wheels to fully lock. In addition, shifting out of low speed range will also disengage the differential lock.

WARNING

Locking the wheels when the vehicle is traveling down steep grades or when the wheels are slipping could damage the differential and/or lead to loss of vehicle control, causing personal injury and property damage.

NOTICE

Engage the differential lock only when the vehicle is stopped or moving slowly at low speed, less than 5 mph (8 km/h). Engaging the differential lock at high speeds can cause internal axle damage.

1. With the engine running, press the upper half of the differential lock switch to engage the differential lock.
2. If the vehicle is moving, briefly let up on the accelerator to relieve torque on the gearing, allowing the differential to fully lock.

WARNING

Be especially careful when driving under slippery conditions with the differential locked. Though forward traction is improved, the vehicle can still slip sideways, causing possible loss of vehicle control, personal injury, and property damage.

3. Drive cautiously and do not exceed 25 mph (40 km/h). When the differential is fully locked, the turning radius will increase because the vehicle understeers. See [Fig. 15.3](#).

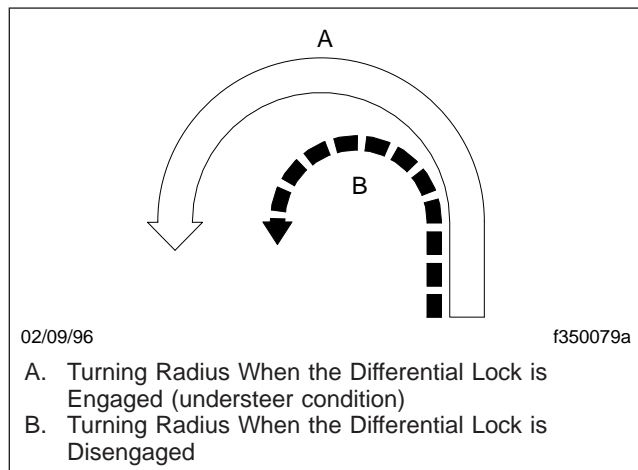

Fig. 15.3, Turning Radii

4. Press the upper half of the differential lock switch again to disengage the differential lock after leaving poor road conditions.

NOTE: If the differential lock is engaged when the engine is shut down, the differential lock will disengage.

5. If the vehicle is moving, briefly let up on the accelerator to allow the wheels to fully unlock, then resume driving at normal speed.

Single Drive Axles with Traction Equalizer

Some single drive axles are equipped with a traction equalizer that is a load-sensing, self-actuating feature. A traction equalizer provides normal differential action where traction is good. When one wheel begins to spin faster than the other, clutch plates in the differential housing automatically engage, delivering power to both wheels. There is no operator control with this feature.

NOTICE

Tire sizes on both rear wheels should be the same on axles equipped with a traction equalizer. If not, excessive wear may occur in the traction equalizer.

Interaxle Lock, Tandem and Tridem Axles

The interaxle lock (axle lock, interaxle differential lockout) feature causes the drive axle shafts to rotate together, and is recommended for use under adverse road conditions where greater traction is needed.

See the axle manufacturer's website for more information.

When engaged, the interaxle lock essentially makes the driveshaft a solid connection between the drive axles. Power entering the forward axle is transmitted straight through to the rearmost axle(s). Driveline torque is now delivered equally and the drive axles, and wheels, turn together at the same speed. The interaxle lock increases drivetrain and tire wear and should be used only when improved traction is required.

Interaxle Lock Switch

The interaxle lock switch ([Fig. 15.4](#)) allows the driver to lock the drive axles together.

Drive Axles

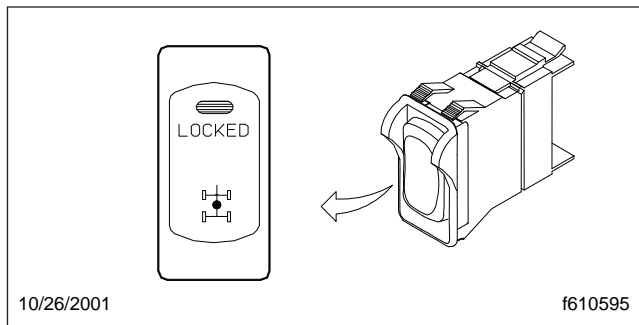

Fig. 15.4, Interaxle Lock Switch

When the interaxle lock switch is pressed, three responses are possible:

- *Normal Response:* The LED in the switch blinks until the interaxle lock is engaged. At this point, the LED illuminates steadily. In normal operation, the interaxle lock may engage so quickly that the blinking of the switch is barely noticeable.
If engagement of the interaxle lock mechanism is not possible for any reason (ignition is turned off, vehicle is moving too fast, etc.), the LED will stop blinking and turn off.
- *Slow Response:* If engagement of the interaxle lock mechanism is slowed for any reason (by cold weather, low air pressure, etc.), the switch will continue to blink until the axles lock together, or for a maximum of 10 seconds. As in the normal response, the LED illuminates steadily once the lock mechanism is engaged.
- *Abnormal Response:* If the LED blinks for more than 30 seconds, the lock mechanism may not be fully engaged/disengaged. Bring the vehicle to an authorized Freightliner service facility for testing.

Interaxle Lock Operation

NOTICE

The interaxle lock should not be engaged on a vehicle with obviously spinning wheels. Engagement at high speed or power can damage the axle(s).

1. With the engine running, press the upper half of the interaxle lock switch to engage the interaxle

lock. Do not wait until traction is lost and the tires are spinning before engaging the interaxle lock.

2. If the vehicle is moving, briefly let up on the accelerator until the interaxle lock engages. The red interaxle indicator light illuminates on the dash message center when interaxle lock is engaged.

NOTICE

Do not operate the vehicle continuously with the interaxle locked during extended good road conditions. To do so could result in damage to the axle gearing and excessive driveline and tire wear.

3. Proceed over poor road conditions with caution.
4. Press the upper half of the interaxle lock switch again to disengage the interaxle lock after leaving poor road conditions.

NOTE: If the interaxle lock is engaged when the engine is turned off, the interaxle lock will disengage.

5. If the vehicle is moving, briefly let up on the accelerator to allow the interaxle lock to disengage, then resume driving at normal speed. Once the interaxle lock disengages, the indicator light will go off.

16

Steering System

Power Steering System	16.1
-----------------------------	------

Steering System

Power Steering System

The power steering system includes the power steering gear, hydraulic hoses, power steering pump, reservoir, steering wheel and column, and other components. Some models are also equipped with a separate hydraulic power cylinder on the right side of the front axle, or a right-hand slave gear.

The power steering pump, driven by the engine, provides the power assist for the steering system. If the engine is not running, there is no power assist.

WARNING

Driving the vehicle without the power-assist feature of the steering system requires much greater effort, especially in sharp turns or at low speeds, which could result in an accident and possible injury.

If the power-assist feature does not work due to hydraulic fluid loss, steering pump damage, or another cause, bring the vehicle to a safe stop. Do not drive the vehicle until the cause of the problem has been corrected.

NOTICE

Never steam clean or high-pressure wash the steering gear. Internal damage to gear seals, and ultimately the steering gear, can result.

Drivers should carefully use the power available with a power steering system. If the front tires become lodged in a deep hole or rut, drive the vehicle out instead of using the steering system to lift the tires out of the hole.

NOTICE

Avoid turning the tires when they are against a curb, as this places a heavy load on steering components and could damage them.

Steering Wheel Adjustment

Two steering wheels are available: a standard 18-inch (450-mm) steering wheel and an optional 20-inch (500-mm) steering wheel.

When there is no load on the vehicle and the front tires are pointed straight ahead, the standard steer-

ing wheel spokes should be at the 3 o'clock and 9 o'clock positions or within 10 degrees of these positions. See [Fig. 16.1](#).

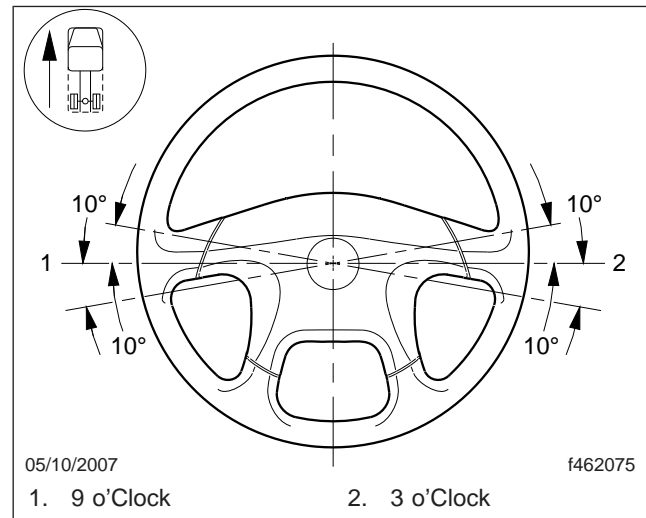

Fig. 16.1, Steering Wheel Centered

On the optional 20-inch (500-mm) wheel, the steering wheel spokes should be at the 4 o'clock and 8 o'clock positions or within 10 degrees of these positions. For steering wheel adjustment procedures, see **Group 46** of the *108SD and 114SD Workshop Manual*.

17

Fifth Wheels

Fifth Wheels, General Information	17.1
Fifth Wheel Coupling	17.1
Fifth Wheel Uncoupling	17.4
Fifth Wheel Slide	17.7

Fifth Wheels

Fifth Wheels, General Information

WARNING

Do not use any fifth wheel that fails to operate properly. Doing so may cause loss of vehicle control, possibly resulting in severe personal injury or death.

Air-Suspension Dump Valve

The air-suspension dump valve may be used to adjust the vehicle height in order to aid with coupling to or uncoupling from a trailer. See [Fig. 17.1](#). When the switch is set to LOWER, the air-suspension dump valve deflates the air springs to lower the rear of the vehicle. In the AUTO position, the automatic ride-control valves operate for normal driving.

WARNING

Never exhaust air from the suspension while driving. The suspension will not absorb road shocks, possibly damaging components, and vehicle handling may be compromised. This could result in loss of vehicle control, possibly resulting in severe personal injury or death.

NOTICE

Do not operate the vehicle over uneven ground such as ramps, speed bumps, curbs, etc. with the air springs deflated. Doing this may lead to air bag separation from the piston, preventing the suspension air springs from inflating.

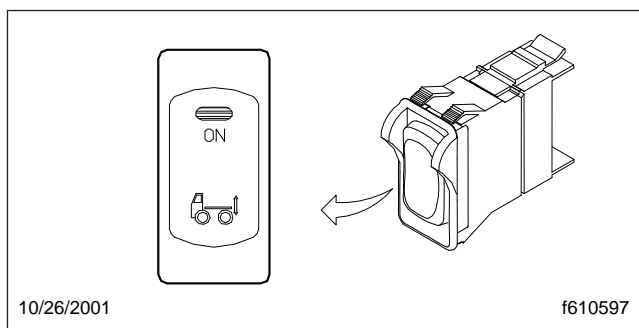

Fig. 17.1, Air-Suspension Dump Valve

Fifth Wheel Lubrication

WARNING

Keep the fifth wheel plate lubricated to prevent binding between the tractor and trailer. A binding fifth wheel could cause erratic steering and loss of vehicle control, possibly resulting in personal injury or death.

The standard fifth wheel plate must be kept well lubricated with chassis grease to prevent friction and binding between the vehicle fifth wheel plate and the trailer.

For a low-lube fifth wheel plate, inspect the condition of the low-lube pads. There should be no damaged or missing pieces. Slight puckering at the outside edges is normal.

For lubrication instructions, see **Group 31** of the *108SD and 114SD Maintenance Manual*.

Fifth Wheel Coupling

Fifth wheel coupling is activated with the lock control handle located on either the right or left side of the fifth wheel. Coupling is complete when the kingpin has been forced into the jaws and the lock control handle has moved to the locked position.

NOTICE

Some fifth wheels may be mounted on sliding rails. Before attempting to couple a trailer to a sliding fifth wheel, the slide feature must be locked to prevent the top plate from sliding rapidly forward or rearward, causing damage to the fifth wheel or kingpin.

Fontaine and Holland Fifth Wheels Coupling

1. Check the front and rear trailer tires.
2. Ensure the fifth wheel jaw is fully open and the operating rod is in the unlocked position. See [Fig. 17.2](#) or [Fig. 17.3](#).
3. Make sure the fifth wheel top plate is tilted so the ramps are as low as possible.

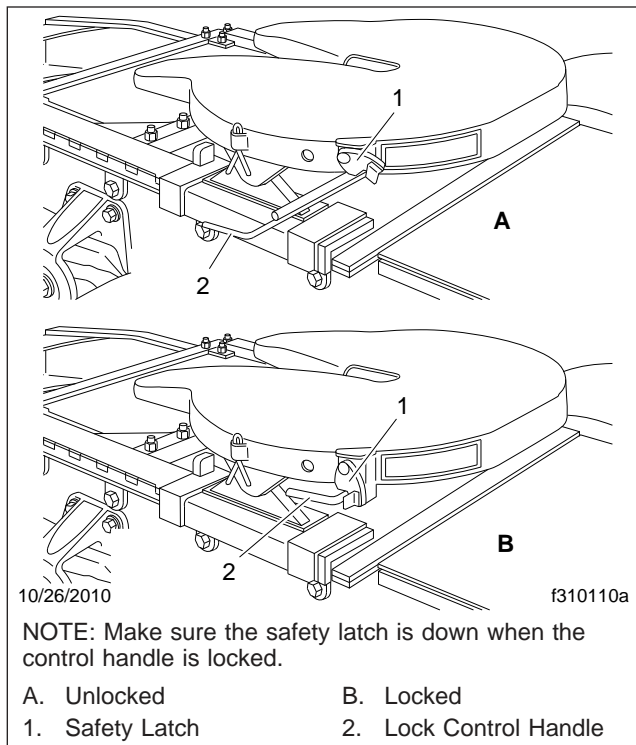

Fig. 17.2, Fontaine Locking Mechanism

- Position the vehicle so that the center of the fifth wheel is in line with the trailer kingpin. The kingpin should be in a position to enter the throat of the locking mechanism.

NOTICE

Attempting to couple at the wrong height may cause improper coupling, which could result in damage to the fifth wheel or kingpin.

- Adjust the trailer height if required.
For a standard fifth wheel plate, the trailer should contact the fifth wheel approximately 4 to 8 inches (10 to 20 cm) behind the fifth wheel pivot. See [Fig. 17.4](#).
For a low-lube fifth wheel plate, the fifth wheel must slide freely under the trailer, and the trailer should contact the fifth wheel at the pivot. See [Fig. 17.5](#).
- With the fifth wheel lock opening aligned with the trailer kingpin, back the vehicle slowly toward the trailer. After sliding under the trailer, STOP to

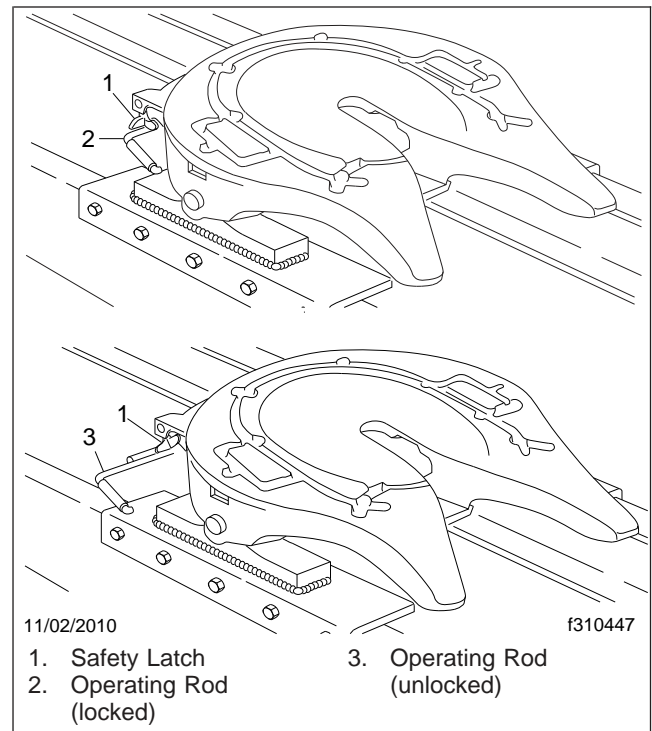

Fig. 17.3, Holland Simplex SE Locking Mechanism

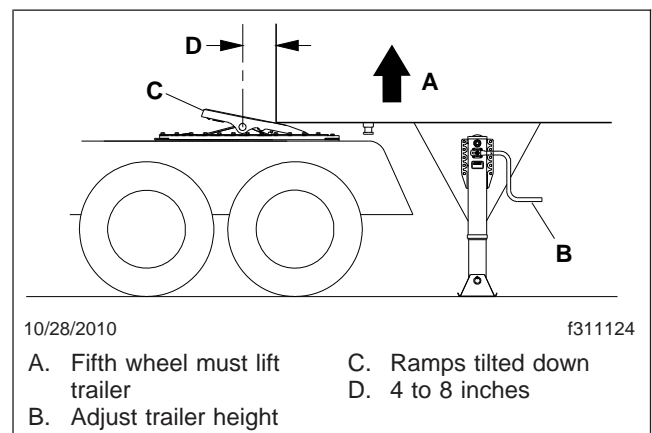

Fig. 17.4, Trailer Connection Point, Standard Fifth Wheel Plate

prevent from hitting the kingpin too hard, then resume backing slowly until the fifth wheel locks.

On a standard fifth wheel, the fifth wheel must lift the trailer.

On a low-lube fifth wheel, do not lift the trailer as this may damage the fifth wheel plate.

Fifth Wheels

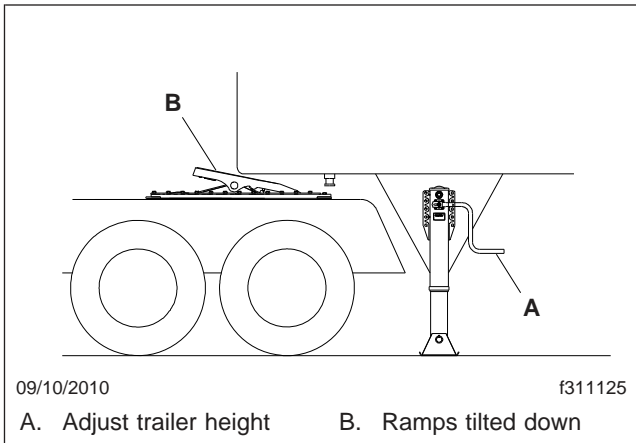

Fig. 17.5, Trailer Connection Point, Low-Lube Fifth Wheel Plate

7. Apply the vehicle parking brake.

WARNING

A visual inspection is required by law. Some improper couplings can pass a pull test. Sound is not reliable. Get out of the cab and look. Incorrect coupling could cause the trailer to disconnect, possibly resulting in serious personal injury or death.

8. Perform a coupling inspection, checking that there is no gap between the bottom of the trailer and the fifth wheel, and that the kingpin is securely locked. See [Fig. 17.6](#)

When lockup has occurred, the fifth wheel control handle moves to the locked position. Make sure that the safety latch is down over the lock control handle to hold the control handle in the locked position (the safety latch will only rotate down if the operating rod is fully retracted in the locked position). See [Fig. 17.2](#) for Fontaine fifth wheels. See [Fig. 17.3](#) for Holland fifth wheels.

9. Release the vehicle parking brake. Test for kingpin lockup by slowly inching the vehicle forward, pulling on the trailer against the chocks.
10. After lockup is completed, connect the tractor-to-trailer air system lines and the electrical cable to the trailer. Take care to prevent dirt or foreign material from entering the air system lines.

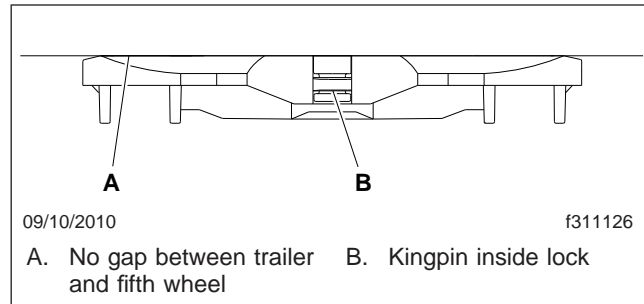

Fig. 17.6, Coupling Inspection

NOTICE

Always make sure the connection hanger keeps the trailer air hoses and electrical cables positioned so that they do not rub on anything. Rubbing may wear through hoses or cables, resulting in air leaks, or exposed or broken wires, potentially affecting trailer brake or electrical systems.

11. Charge the air brake system with air, checking that the air connections do not leak.

WARNING

Incorrect fifth wheel lock adjustment could cause the trailer to disconnect, possibly resulting in serious personal injury or death.

12. With the trailer tires chocked and the brakes set, check for clearance between the kingpin and the fifth wheel jaws by moving the vehicle forward and backward against the locked kingpin. If slack is present, uncouple the trailer and have the fifth wheel inspected and adjusted by a certified technician.

Jost Fifth Wheel Coupling

1. Tilt the ramp down.
2. Open the kingpin locks. See [Fig. 17.7](#).
3. Back the vehicle close to the trailer, centering the kingpin on the fifth wheel.
4. Chock the trailer tires.
5. Connect the air lines and electrical cable.
6. Ensure that the red trailer air supply valve (trailer brake) is pulled out, and that the trailer parking

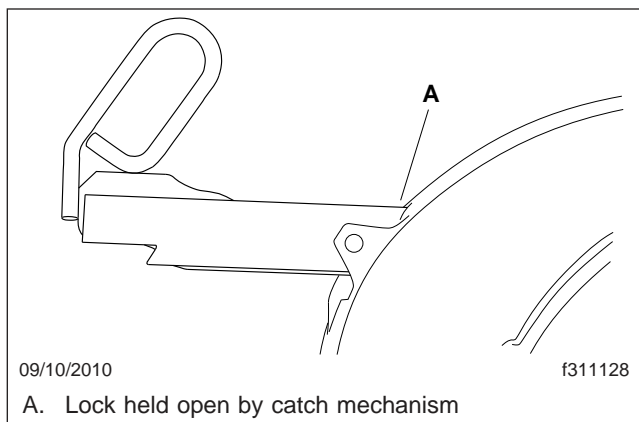

Fig. 17.7, Jost Release Handle Unlocked

brakes are set. See [Chapter 5](#) in this manual for operation of the dash-mounted brake controls.

NOTICE

Attempting to couple at the wrong height may cause improper coupling, which could result in damage to the fifth wheel or kingpin.

7. Adjust the trailer height (if required).
 - For a standard fifth wheel plate**, the trailer should contact the fifth wheel approximately 4 to 8 inches (10 to 20 cm) behind the pivot. See [Fig. 17.4](#).
 - For a low-lube fifth wheel plate**, the fifth wheel must slide freely under the trailer, and the trailer should contact the fifth wheel at the pivot. See [Fig. 17.5](#).
8. Back the vehicle under the trailer.
 - On a standard fifth wheel, the fifth wheel must lift the trailer.
 - On a low-lube fifth wheel, do not lift the trailer as this may damage the fifth wheel plate.
9. After sliding under the trailer, STOP to prevent from hitting the kingpin too hard, then resume backing slowly until the fifth wheel locks.
10. Apply the vehicle parking brake.

WARNING

A visual inspection is required by law. Some improper couplings can pass a pull test. Sound is

not reliable. Get out of the cab and look. Incorrect coupling could cause the trailer to disconnect, possibly resulting in serious personal injury or death.

11. Perform a physical check for positive kingpin lockup, ensuring that there is no gap between the trailer and the fifth wheel. See [Fig. 17.6](#).
12. Ensure that the release handle is in the locked position adjacent to the casting. See [Fig. 17.8](#).
13. Release the vehicle parking brake and test for kingpin lockup by slowly moving the vehicle forward, pulling on the trailer against the chocks.

Fifth Wheel Uncoupling

Manual Uncoupling

1. Apply the vehicle and trailer parking brakes.
2. Chock the trailer rear wheels.
3. Lower the trailer landing gear until the weight is removed from the fifth wheel.
4. Disconnect the tractor-to-trailer air system lines and electrical cable. Plug the air lines to prevent dirt or foreign material from entering the lines.
5. Verify that both the yellow parking-brake and red trailer air supply knobs are out, the vehicle and trailer parking brakes are set, and that the trailer is prepared for uncoupling.
6. Release the kingpin locking mechanism following the instructions for each manufacturer listed below.
 - 6.1 **Fontaine:** Lift the safety latch and pull the lock control handle to the unlocked position. See [Fig. 17.2](#).
 - 6.2 **Holland:** In the locked position the safety indicator swings freely over the operating rod. See [Fig. 17.9](#), View A.

To unlock the mechanism, manually rotate the safety indicator toward the rear of the fifth wheel. See [Fig. 17.9](#), View B.

Pull the operating rod out. When the upper operating rod shoulder is outside the slot, raise the handle and place the shoulder of the upper rod against the plate casting, above the slot. See [Fig. 17.9](#), View C.

Fifth Wheels

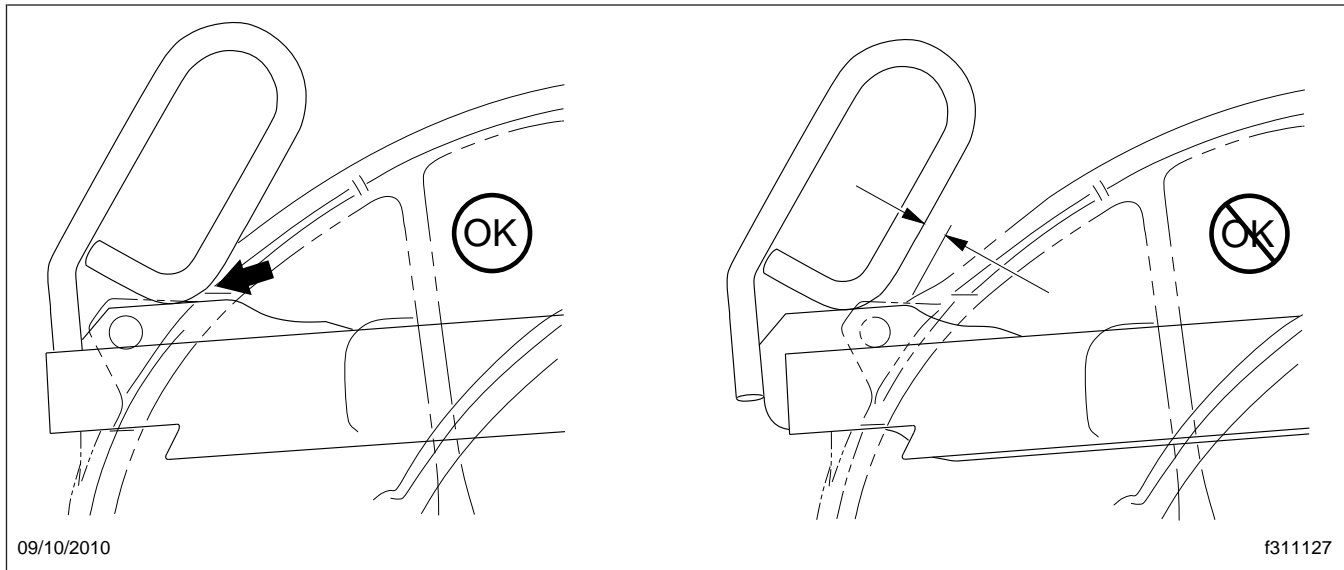

Fig. 17.8, Jost Release Handle Locked

The fifth wheel is now in the lockset position and is ready for uncoupling. As the vehicle pulls away from the trailer the kingpin forces the jaw to rotate, contacting the lock. Continued rotation of the jaw forces the lock to move outward, and drops the upper rod back into the slot. See Fig. 17.9 View D. The wheel is now ready for coupling.

- 6.3 **Jost:** Pull the retractable handle out, then secure it in the open position with the catch. See Fig. 17.7.
7. Release the vehicle parking brake, then drive forward slowly, allowing the trailer to slide down the fifth wheel and pick-up ramps.

Air-Actuated Uncoupling

An air-actuated kingpin release valve is optional with all fifth wheels. See Fig. 17.10.

NOTE: In the event of an air system failure, air-actuated kingpins can be manually released following the instructions for manual unlocking.

WARNING

Once the kingpin release valve has been pulled the kingpin lock is released. The vehicle **MUST NOT** be driven with the trailer until the trailer has

been uncoupled and coupled again. Failure to do so may result in separation of the trailer from the tractor, possibly causing serious personal injury or death.

Preparing the Trailer for Uncoupling

Before using the air valve to unlock a fifth wheel kingpin, prepare the trailer as follows.

1. Apply the vehicle and trailer parking brakes.
2. Chock the rear trailer tires.
3. Lower the trailer landing gear until the weight is removed from the fifth wheel.
4. Disconnect the tractor-to-trailer air lines and electrical cable. Plug the air lines to prevent dirt or foreign material from entering the lines.

Air-Activated Kingpin Unlock, Fontaine and Holland Fifth Wheels

1. Verify that both the yellow parking-brake and red trailer-air supply knobs are out, the vehicle and trailer parking brakes are set, and that the trailer is prepared for uncoupling.

NOTE: If the vehicle parking brake is not set, the air-actuated kingpin-release valve will not activate.

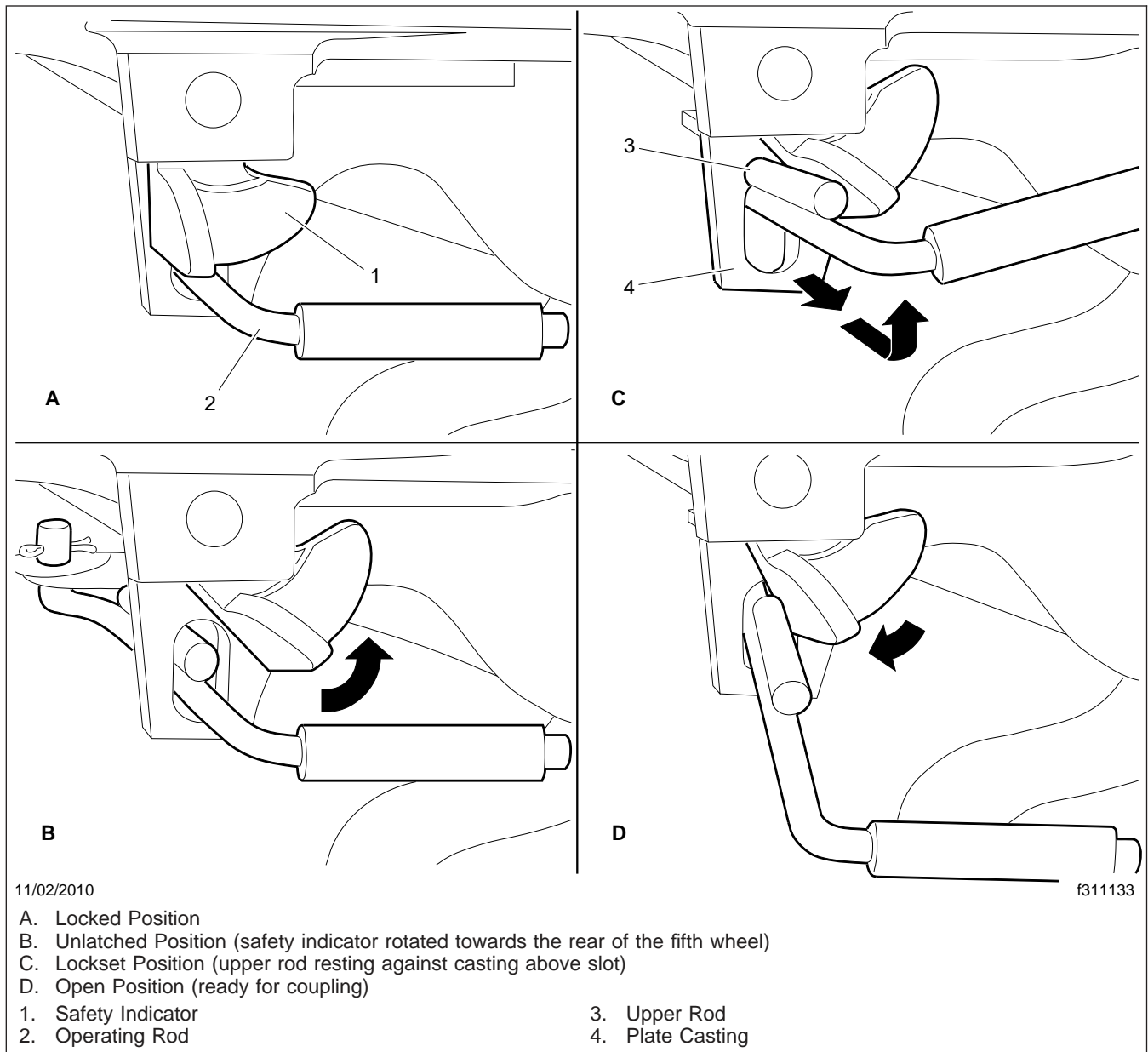

Fig. 17.9, Holland Kingpin Locking Mechanism

2. Pull and hold the kingpin release valve until the kingpin lock mechanism opens and locks in place. See [Fig. 17.10](#).
3. Let go of the kingpin release valve.
4. Release the vehicle parking brake.
5. Drive out from under the trailer.

Air-Activated Kingpin Unlock, Jost Fifth Wheels

1. Verify that both the yellow parking-brake and red trailer air supply knobs are out, the vehicle and trailer parking brakes are set, and that the trailer is prepared for uncoupling.

Fifth Wheels

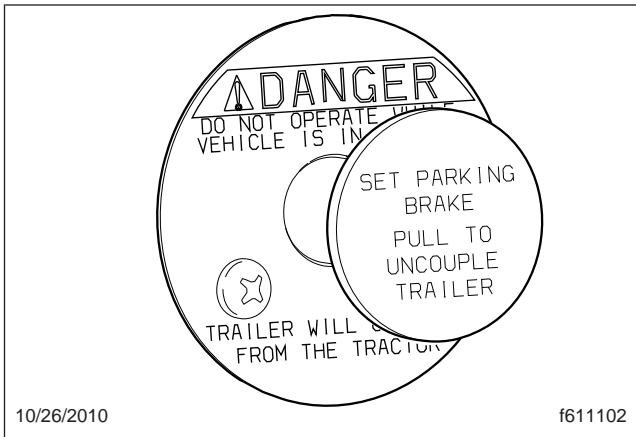

Fig. 17.10, Air-Actuated Kingpin Release Valve

NOTE: If the trailer parking brake is not set, the air-actuated valve will not activate.

2. Release the vehicle parking brake.
3. Pull and hold the kingpin release valve, then drive forward slowly.
4. After the trailer has slid down the fifth wheel and pick-up ramps, let go of the kingpin release valve.

Fifth Wheel Slide

WARNING

Adjust the fifth wheel slide correctly, and do not overload any tractor axle by incorrectly loading the trailer. Incorrect slide adjustment or improper axle loading could cause erratic steering and loss of vehicle control, possibly resulting in serious personal injury or death.

On sliding fifth wheel assemblies, the fifth wheel plate is attached to rails that allow forward and rearward movement of the fifth wheel in order to optimally distribute the load across the axles. Slots are evenly spaced along the slide rails, and retractable wedges are positioned through the slots to hold the fifth wheel in the desired position.

The amount of load distribution on the front steering axle and rear drive axle(s) will have a direct effect on the steering control of the vehicle. Determine the front and rear axle weights by weighing the vehicle on scales designed for this purpose.

The maximum axle weight ratings are shown on the Federal Motor Vehicle Safety Standard (FMVSS) label or Canadian Motor Vehicle Safety Standard (CMVSS) label attached to the left rear door post of the vehicle. The desired load on the axle is no less than 80 percent of the maximum axle weight rating, but in no instances should the axle load exceed the maximum axle weight rating given on the FMVSS or CMVSS label.

Manual Slide Operation

Use the following procedure to manually slide the fifth wheel. See Fig. 17.11.

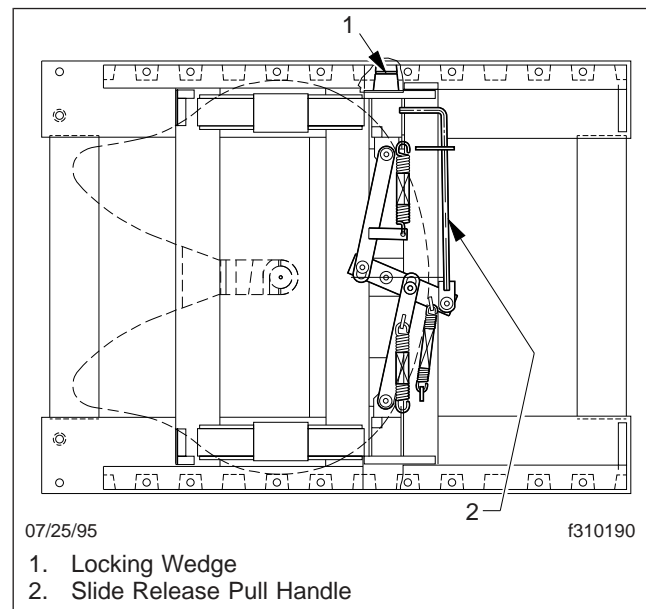

Fig. 17.11, Manual Release Sliding Fifth Wheel, Fontaine

1. Stop the vehicle and trailer in a straight line on level ground. Pull the red trailer air supply knob to apply the trailer parking brakes.
2. Apply the vehicle parking brake, then release the sliding mechanism using the appropriate method for the fifth wheel manufacturer.
 - 2.1 **Fontaine:** Lift the slide release pull handle to disengage it from the guide plate. Then, pull out the handle until it is in the unlocked position and can be positioned against the guide plate to hold it out. The

handle will stay in the unlocked position until it is manually disengaged from the guide plate. See **Fig. 17.12**.

- 2.2 **Holland:** Pull the operating rod out. Make sure both side plungers have released. See **Fig. 17.13**.
3. Lower the trailer landing gear just enough to remove the weight from the vehicle.

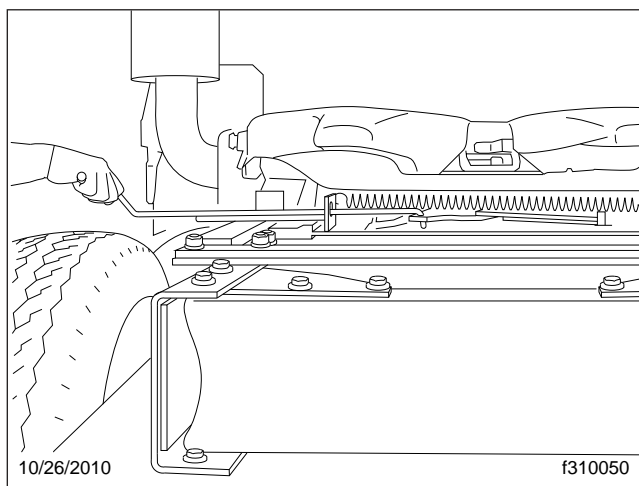

Fig. 17.12, Sliding Fifth Wheel Manual Release, Fontaine

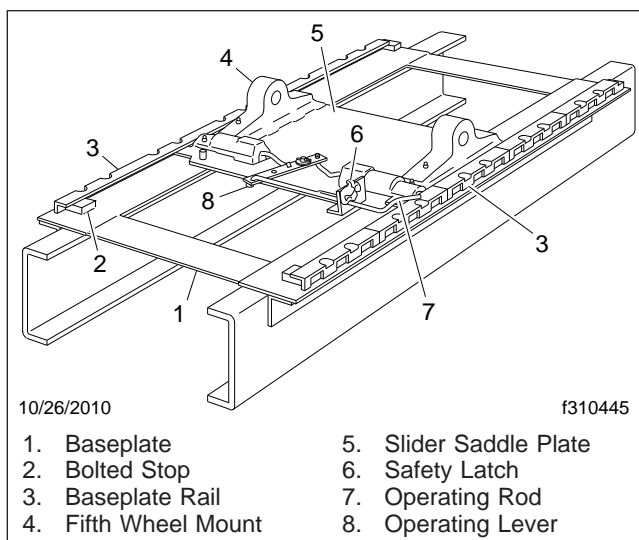

Fig. 17.13, Sliding Fifth Wheel Manual Release, Holland Simplex

4. Check the front and rear trailer tires to prevent the trailer from moving.

NOTICE

When moving the fifth wheel to the desired position, be sure the trailer landing gear will not at any time come in contact with the vehicle frame or other components. Make sure that the front of the trailer will not come in contact with the rear of the cab or with other components if they extend beyond the rear of the cab.

5. Release the vehicle parking brake, then slowly move the vehicle forward or backward until the fifth wheel is in the desired location.

! WARNING

Check that the locking wedges have seated in the slots. Failure to achieve complete lockup may allow disengagement of the tractor from the trailer, possibly resulting in serious personal injury or death.

6. Apply the vehicle parking brake, then lock the sliding member in position using one of the following methods:
 - 6.1 **Fontaine:** Disengage the slide release pull handle from the guide plate. The slide release pull handle is spring-loaded in the locked position and will seek the locked position when disengaged from the guide plate. After the slide release pull handle returns to the fully locked position, visually and physically check the locking wedges to make sure they are fully inserted into the slots in the slide rails. Make sure the handle is locked in position against the guide plate.
 - 6.2 **Holland:** Raise the operating rod so that it is free to move inward. Make sure that the lock pins have seated in the base plate rail holes and the operating rod moves into the locked position.

NOTE: The fifth wheel may need to be moved slightly to enable the locking wedges to enter the fully locked position.

Fifth Wheels

Air Slide Operation

The slide feature may be operated with a dash-mounted air-slide switch that operates an air cylinder that locks and unlocks the slide. See **Fig. 17.14**.

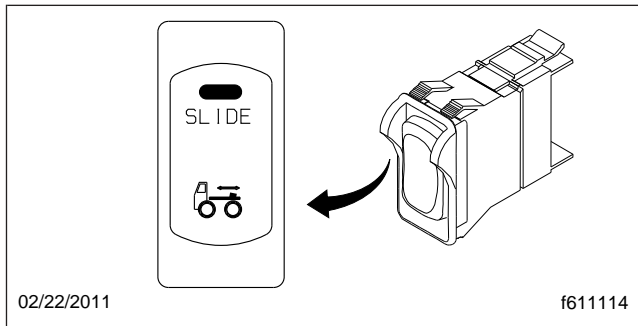

Fig. 17.14, Air-Slide Switch

1. Set the air-slide switch to SLIDE. See **Fig. 17.14**. Ensure the locking plungers have released. See **Fig. 17.15**. For Jost fifth wheels, the mechanism activates as shown in **Fig. 17.16**.

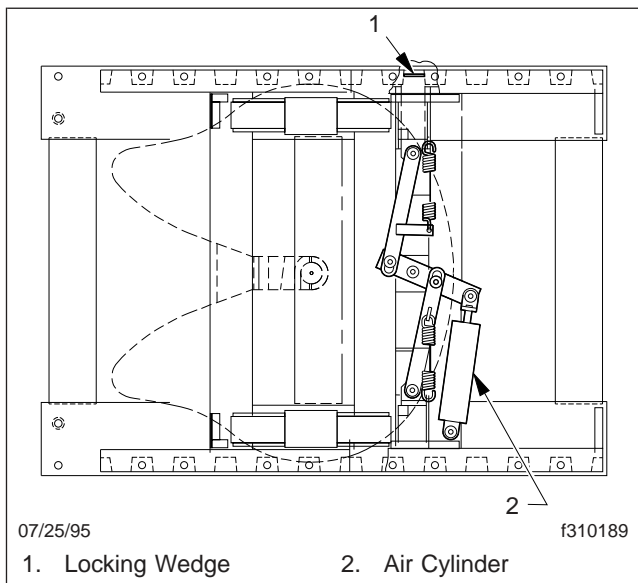

Fig. 17.15, Air-Operated Sliding Fifth Wheel, Fontaine

2. Lower the trailer landing gear just enough to remove the weight from the vehicle.
3. Pull the red trailer air supply knob to set the trailer parking brakes.

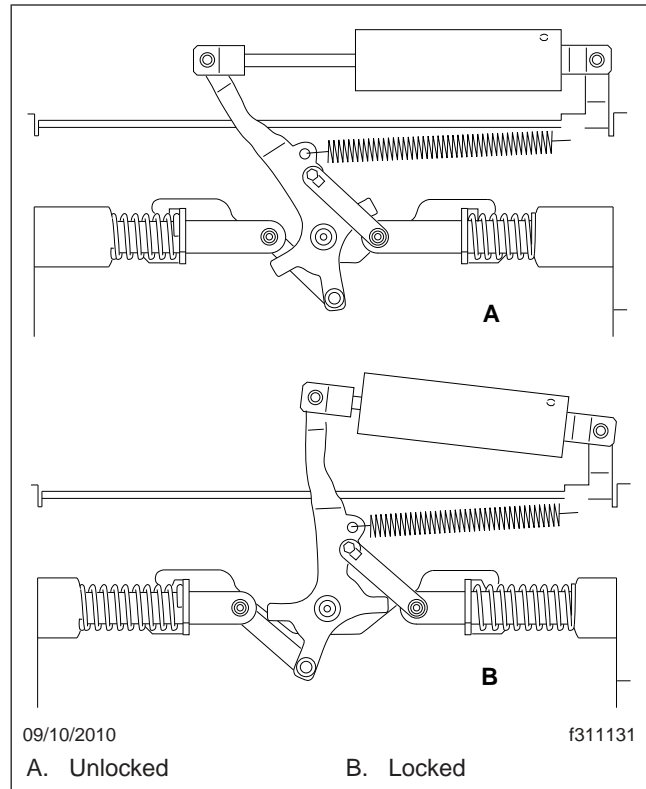

Fig. 17.16, Jost Sliding Fifth Wheel

4. Slowly move the vehicle forward or backward until the fifth wheel is in the desired location.

NOTICE

Ensure the trailer landing gear does not come in contact with the vehicle frame or other components, and that the front of the trailer will not come in contact with the rear of the cab or other components if they extend beyond the rear of the cab.

5. Apply the vehicle parking brake.

WARNING

Check that the locking wedges have seated in the slots. Failure to achieve complete lockup may allow disengagement of the tractor from the trailer, possibly resulting in serious personal injury or death.

6. Set the air-slide switch to LOCK. Visually inspect the locking wedges or plungers to make sure that they are fully inserted in the slide rail slots. Verify that the plungers have engaged by tugging the vehicle forward while the trailer brakes are locked and the tires are chocked.

NOTE: The fifth wheel may need to be moved slightly to enable the locking wedges to fully lock.

18

Trailer Couplings

Air-Suspension Dump Valve	18.1
Holland Trailer Coupling	18.1
Premier Trailer Couplings	18.2

Trailer Couplings

Air-Suspension Dump Valve

The air-suspension height switch may be used to aid in connecting or disconnecting from a trailer. When the switch is set to LOWER, the air-suspension dump valve deflates the air springs to lower the rear of the vehicle. In the normal position, the automatic ride-control valves operate for normal driving.

NOTICE

Do not operate the vehicle over uneven ground such as ramps, speed bumps, curbs, etc. with the air springs deflated. Doing this may lead to air bag separation from the piston, preventing the suspension air springs from reinflating.

NOTICE

Never exhaust air from the suspension while driving. When the air is exhausted, the suspension will not absorb road shocks, and components may be damaged.

Holland Trailer Coupling

General Information

IMPORTANT: Refer to the Holland web site (www.hollandhitch.com) for additional information.

The Holland trailer coupling (**Fig. 18.1**) is designed for use with trailers having a maximum gross weight of 49,000 lbs (22 226 kg). It is a swivel-mount pintle hook designed for heavy-duty construction, utility, and off-road applications. It is fastened to the rear closing crossmember of the vehicle and is a non-air-adjusted coupling.

Trailer Hookup

1. Chock the front and rear tires of the trailer.
2. Remove the cotter pin, then lift the lock and raise the latch.
3. Back the vehicle up until the drawbar eye is over the horn of the pintle hook.
4. Lower the trailer until the drawbar eye rests on the pintle hook.
5. Close the latch, then insert the cotter pin.

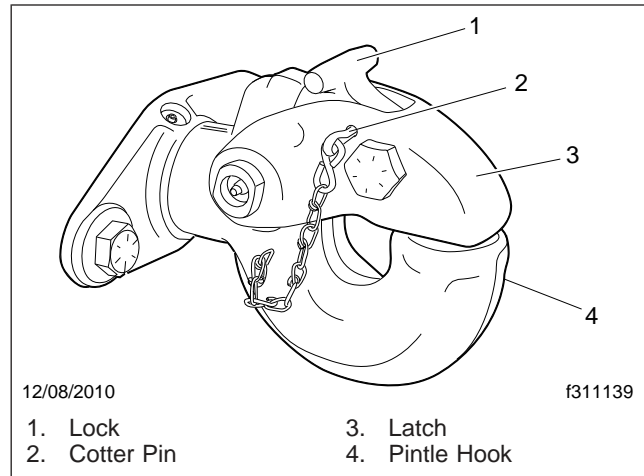

Fig. 18.1, Holland PH-760 Trailer Coupling

NOTICE

Always make sure the connection hanger keeps the trailer air hoses and electrical cables positioned so that they do not rub on anything. Rubbing may wear through hoses or cables, resulting in air leaks, or exposed or broken wires, potentially affecting trailer brake or electrical systems.

6. Connect the trailer electrical and air lines.

Trailer Release

1. Apply the truck and trailer parking brakes.

WARNING

Do not use the trailer air supply for parking trailers not equipped with spring parking brakes. This applies the trailer service brakes only. As air bleeds from the trailer brake system, brake application is lost. This could allow the unattended vehicle to roll away, possibly resulting in serious personal injury or death.

2. Chock the front and rear tires of the trailer.
3. Disconnect the trailer air and electrical lines. Plug the air lines to keep them free of dirt.
4. Take the weight of the trailer drawbar off the pintle hook.
5. Open the latch by first removing the cotter pin, then lift up the lock and raise the latch.

6. Slowly drive the vehicle away from the trailer.

Premier Trailer Couplings

General Information

IMPORTANT: Before operating the Premier coupling, refer to the Premier web site at www.premier-mfg.com for complete safety, operation, and maintenance instructions.

Trailer couplings are attached to the rear closing crossmember. The Premier trailer couplings (**Fig. 18.2**) are designed for use with trailers having a maximum gross weight of 100,000 lbs (45 455 kg).

The Premier 2200 and 2400 trailer couplings are air adjusted couplings with a rigid pintle hook, attached to the rear closing crossmember. An air chamber, mounted forward of the coupling, operates a push rod, which pushes against a shoe inside the coupling. The shoe maintains constant pressure on the eye of the trailer drawbar when it's over the pintle hook. This takes up any slack in the trailer connection, providing smoother towing and less wear on the pintle hook. The air pressure is activated when the trailer brakes are released.

Trailer Hookup

1. Chock the front and rear tires of the trailer.
2. Push the latch lock towards the mounting plate as far as possible then, while holding the latch lock in place against the mounting plate, pull the top of the latch as far as possible toward the pintle hook.
3. While holding the latch in place, release the latch lock.
4. Back the vehicle up until the drawbar eye is over the pintle hook, then lower the trailer.
5. Pull the top of the latch as far as possible toward the pintle hook then, while holding the latch in position, push the latch lock towards the mounting plate.
6. While holding the latch lock in place against the mounting plate, release the latch.
7. Release the latch lock and make sure it is fully seated in the slot on top of the latch.

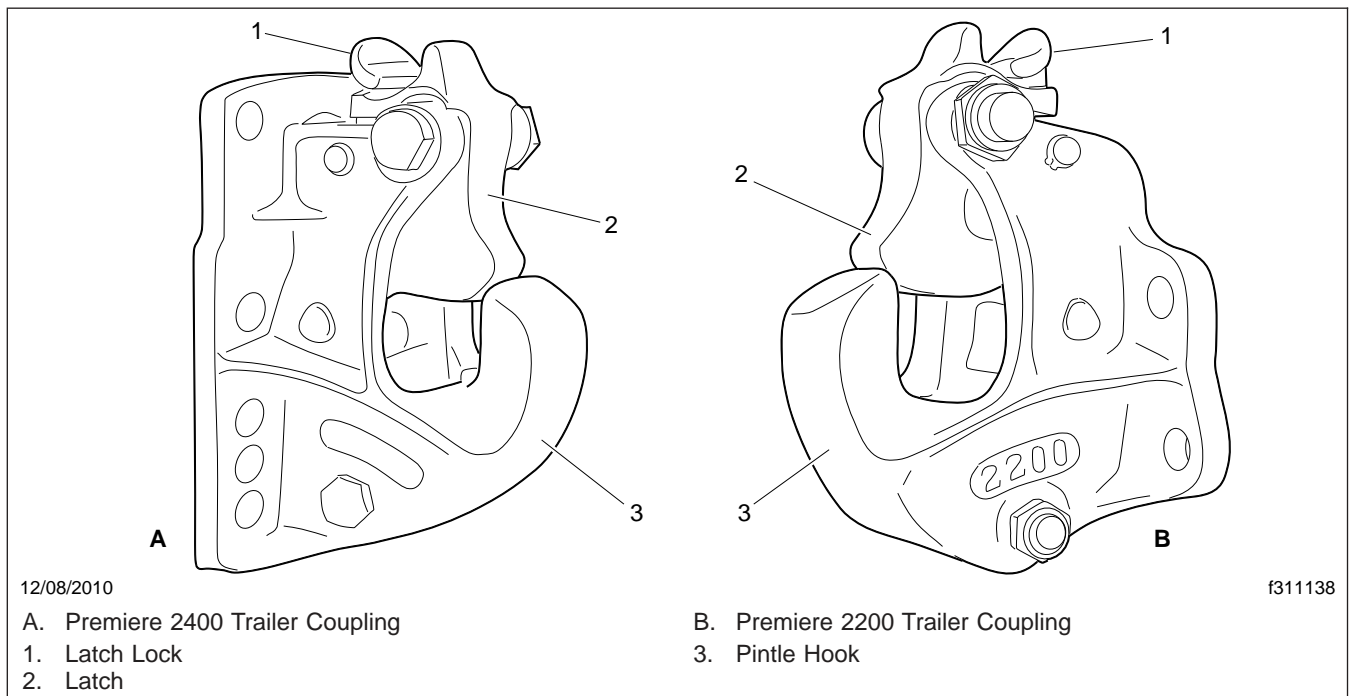

Fig. 18.2, Premiere 2200 and 2400 Trailer Couplings

Trailer Couplings

NOTICE

Always make sure the connection hanger keeps the trailer air hoses and electrical cables positioned so that they do not rub on anything. Rubbing may wear through hoses or cables, resulting in air leaks, or exposed or broken wires, potentially affecting trailer brake or electrical systems.

8. Connect the trailer's electrical and air lines.

Trailer Release

1. Apply the truck and trailer parking brakes.



Do not use the trailer air supply for parking trailers not equipped with spring parking brakes. This applies the trailer service brakes only. As air bleeds from the trailer brake system, brake application is lost. This could allow the unattended vehicle to roll away, possibly resulting in serious personal injury or death.

2. Chock the front and rear tires of the trailer.
3. Disconnect the trailer air and electrical lines. Plug the air lines to keep them free of dirt.
4. Take the weight of the trailer drawbar eye off the pintle hook.
5. Push the latch lock towards the mounting plate as far as possible then, while holding the latch lock in this position, pull the top of the latch as far as possible toward the pintle hook.
6. While holding the latch in place, release the latch lock.
7. Slowly drive the vehicle away from the trailer.

19

Natural Gas Vehicle

Natural Gas Vehicles, General Information	19.1
Natural Gas Vehicles, Safety Precautions	19.1
Natural Gas Fuel Tank Filling Procedures	19.2
Natural Gas Detection System	19.5
Natural Gas Vehicles, Engine Starting	19.9
Major Repair and Replacement of Natural Gas Components	19.10

Natural Gas Vehicle

Natural Gas Vehicles, General Information

The vehicle can be equipped with a compressed natural gas (CNG) fuel system, or a liquefied natural gas (LNG) fuel system. CNG is made by compressing natural gas to less than 1% of its volume at standard atmospheric pressure. LNG is created by condensing natural gas into a liquid by cooling it to approximately -259°F (-162°C). CNG often contains an odor-producing chemical, while LNG does not have any odor.

When vaporized at ambient temperatures, natural gas is less dense than air, and it rises and disperses. However, LNG is initially heavier than air due to its cryogenic temperature. When released in large amounts, it may drop or pool on the ground before its temperature rises enough to vaporize. Cold atmospheric conditions may prevent natural gas from dispersing quickly when released in large amounts.

Natural gas is nontoxic, but it can cause asphyxiation if present in very large concentrations.

For natural gas to burn, it must first vaporize, then mix with air in the proper proportions (flammable range is 5 to 15% by volume in air), and then be ignited.

A typical natural gas fuel system consists of:

- Fuel supply cylinders that store compressed gas at high pressure (CNG), or a tank that stores liquefied gas at an extremely low temperature (LNG).
- A vaporizer or heat exchanging device that changes LNG to gaseous form (LNG fuel systems only).
- Pressure relief and manual fuel shutoff valves.
- A filling connection with a check valve that prevents the gas from flowing back out of the fuel filling line.
- High-pressure and low-pressure fuel filters.
- A pressure control regulator that reduces the high fuel tank or cylinder pressure to the lower pressure needed for the engine.
- A fuel contents gauge that indicates the fuel supply in the tank or cylinders.

Natural Gas Vehicles, Safety Precautions



Natural gas is highly flammable. Failure to observe the following safety precautions could lead to the ignition of the natural gas, which could cause serious bodily injury or death.

Follow these safety precautions when operating or repairing a natural gas vehicle.

- Do not start the engine if a natural gas leak is detected.
- Do not transfer CNG from one vehicle to another, as a buildup of static electricity could cause a spark and ignite the fuel.
- Do not attempt to cut any fuel supply piping components.
- Avoid open flames or sparks near a natural gas vehicle.
- Cover eyes and exposed skin when working on a natural gas fuel system or fueling a natural gas vehicle.
- Permit no smoking or other ignition sources within thirty feet of a natural gas vehicle.
- Have CO₂ fire extinguishers (ABC minimum) located in a highly visible and easily accessible location.
- Use Purple-K powder (PKP) or a similar dry powder to extinguish an LNG fire. Do not attempt use water around an LNG fire.
- Always purge the fuel lines before performing maintenance or repairs on a natural gas fuel system. To purge the lines, close the manual fuel shutoff valve, and start the engine. Let the vehicle idle until the fuel lines are empty and the engine stops.
- Always use a natural gas detector to test the system for leaks, whether an odor is present or not. Routinely inspect the fuel filtering and regulating mechanisms, and the fuel lines. A bubble solution can be used to pinpoint the exact location of leaks.

- Always tighten fasteners and fuel connections to the required torque specification. Overtightening or undertightening could cause leaks.
- Close the fuel shutoff valve(s) before performing maintenance and repairs.
- Do not store a natural gas vehicle indoors for any extended period of time. Do not bring a natural gas vehicle indoors unless the workshop is equipped with a methane detection and ventilation system.

In Case of Emergency

If a vehicle has sustained damage or a leak has been discovered:

1. Turn the ignition switch off, set the parking brake, and disconnect the battery.
2. Remove all ignition sources from the area surrounding the vehicle.
3. If it is safe to do so, close all fuel shutoff valves.
4. Open the vehicle doors to introduce fresh air.
5. Use a natural gas detector to identify leaks in the fuel system.

Natural Gas Fuel Tank Filling Procedures

CNG Vehicle Fueling

CNG is moved from the fuel station storage tanks to the vehicle cylinders through a metered dispenser. During fueling, as pressure inside of the vehicle cylinders increases, so does the temperature. The dispenser shuts off when it determines the CNG cylinders are full.

CNG fuel cylinders cannot be filled to their full capacity of 3600 psi (24 800 kPa) in cooler weather. Since temperature change causes gas to expand and contract, less pressure in the cylinders on a cold day is equal to the same amount of gas at a higher pressure on a warm day. The fuel station dispenser has a temperature-pressure compensating device, which accounts for ambient temperature during fueling. See [Table 19.1](#) for approximate full cylinder pressures at various temperatures.

CNG Temperature/Pressure Compensation Values		
Temperature: °F (°C)	Fill Station Pressure Set Point	
	3000 psi (20 684 kPa) Set Point	3600 psi (24 821 kPa) Set Point
100 (37.8)	3415 (23 546)	4086 (28 172)
90 (32.2)	3276 (22 587)	3909 (26 952)
80 (26.7)	3138 (21 636)	3754 (25 883)
70 (21.1)	3000 (20 684)	3600 (24 821)
60 (15.6)	2861 (19 726)	3445 (23 752)
50 (10)	2723 (18 774)	3288 (22 670)
40 (4.4)	2584 (17 816)	3131 (21 587)
30 (-1.1)	2446 (16 865)	2973 (20 498)
20 (-6.7)	2307 (15 906)	2814 (19 402)
10 (-12.2)	2169 (14 955)	2655 (18 306)
0 (-17.8)	2031 (14 003)	2495 (17 202)
-10 (-23.3)	1893 (13 052)	2336 (16 106)
-20 (-28.9)	1755 (12 100)	2180 (15 031)
-30 (34.4)	1616 (11 142)	2024 (13 955)
-40 (-40)	1477 (10 184)	1868 (12 879)

Table 19.1, CNG Temperature/Pressure Compensation Values

Use the following steps to fuel a CNG vehicle.

1. Shut down the engine and apply the parking brake.

IMPORTANT: Close all windows and doors during the fueling process. Keeping windows and doors closed allows for easier leak detection inside the cab after fueling.



Natural gas fuel tanks, lines, and valves are always pressurized. Always observe safety precautions. Failure to do so could lead to loss of control over a filling hose or to ignition of the natural gas, which could cause serious bodily injury, death, or severe property damage.

2. Ensure all fuel cylinder shutoff valves are open. See [Fig. 19.1](#).
3. Ensure the vehicle fuel system main shutoff valve is open.
4. Open the CNG fuel panel access door and remove the dust cap from the vehicle fuel fill port.

Natural Gas Vehicle

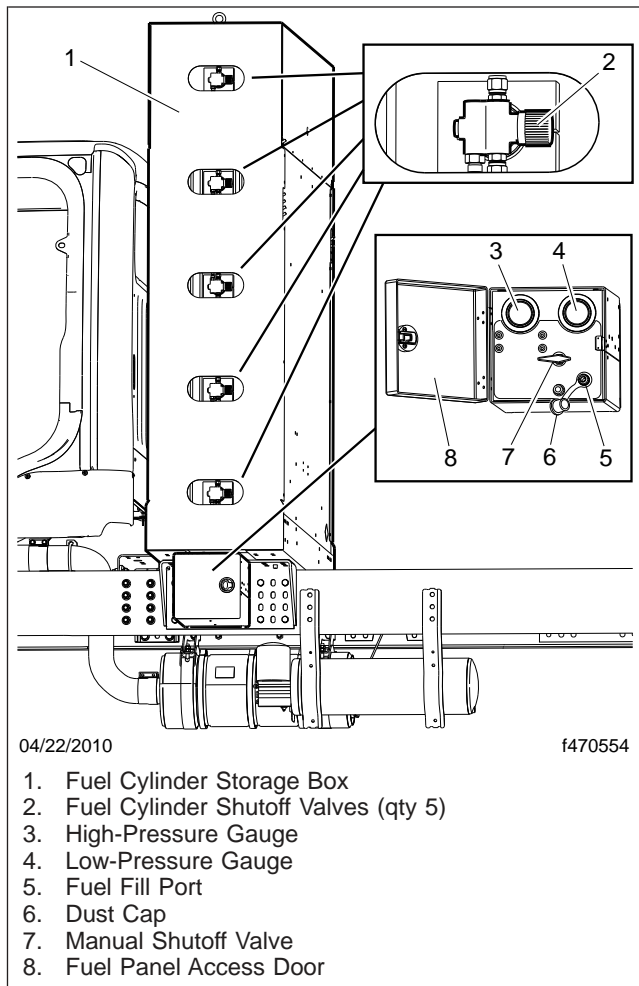

Fig. 19.1, CNG Fuel Cylinder Storage Box (5-cylinder system shown)

5. Ensure the O-ring is present inside the fuel fill port. If the O-ring has been dislodged or is missing, the station dispensing nozzle will not connect securely to the fill port.
6. Turn the selector knob on the service pump to the VENT position, if equipped.
7. Connect the quick coupling on the dispensing nozzle securely to the vehicle fuel fill port.
8. Turn the selector knob on the service pump to the FILL position, if equipped.

IMPORTANT: If at any time the service pump or vehicle begins to vent CNG uncontrollably, notify a station attendant or activate the service sta-

tion emergency shut-off switch to cease the flow of CNG.

9. Switch on the service pump. A slight hissing noise may be heard as the fuel cylinders fill.
10. Watch the pressure gauge on the service pump. When the gauge reads approximately 3600 psi (24 800 kPa), or when the fill pressure stops climbing, the CNG cylinders are full. The service pump will shut itself down automatically. See [Table 19.1](#) for pressure compensation values based on ambient temperatures.
11. Move the selector knob on the service pump to the VENT position, if equipped. A short hiss will be heard as a small amount of natural gas is vented into the hose.

⚠ WARNING

Do not attempt to remove the fill station nozzle from the tank fill fitting until venting of pressure is noted. If no venting occurs, ask for assistance from the station attendant. Removing an unvented coupling could result in an uncontrolled hose, which could lead to property damage or personal injury.

12. Remove the station dispensing nozzle from the vehicle fill port.
13. Install the dust cap on the vehicle fuel fill port and close the fuel panel access door.

LNG Vehicle Fueling

The LNG fuel tank is designed to be filled from any LNG fuel source that has a 100 micron or finer fuel filter and a fuel delivery pressure between 120 and 225 psi (827 and 1551 kPa).

The LNG fuel tank is designed to be top-filled through a single hose with no vent return. As cold LNG is sprayed into the vapor space of the tank, the cold liquid condenses the vapor and creates space for itself inside the tank, eliminating any need to vent during the filling process.

The LNG tank is equipped with a small internal ullage tank for vapor space, which allows for fuel expansion and increases vehicle standby time. When an LNG tank is full, fuel can continue to flow into the ullage tank. However, if the ullage tank is completely filled during fueling, standby time will be reduced to

zero and the primary relief valve will open almost immediately after fueling, allowing excess LNG vapor to escape. If fueling is stopped when the ullage tank is empty (i.e., the fuel tank has sufficient vapor space to accommodate fuel expansion due to temperature increase), the vehicle will have approximately one week of standby time before venting will occur.

Use the following steps to fuel an LNG vehicle.

1. Shut down the engine and apply the parking brake.

IMPORTANT: Close all windows and doors during the fueling process. Keeping windows and doors closed allows for easier leak detection inside the cab after fueling.

WARNING

Liquefied natural gas is a cryogenic liquid stored at approximately -259°F (-162°C). Cryogenic burns can be caused by coming into contact with the pressurized liquid stream, or by coming into contact with fuel system components that have been cooled to cryogenic temperatures. Always wear gloves and a face shield, and cover exposed skin when fueling.

2. Remove the fuel fill fitting dust cap. See [Fig. 19.2](#).
3. Using compressed air, remove any dirt, debris, or water that may have collected in the fuel fill fitting and the station dispensing nozzle. Contaminants in the fuel system can cause drivability problems.

WARNING

Natural gas fuel tanks, lines, and valves are always pressurized. Always observe safety precautions. Failure to do so could lead to loss of control over a filling hose or to ignition of the natural gas, which could cause serious bodily injury, death, or severe property damage.

4. Connect the station fueling nozzle to the tank fuel fill fitting.
5. Connect an electrical ground clamp and cable to the fuel tank.

IMPORTANT: An LNG tank which is first installed, or is on a vehicle that has not been op-

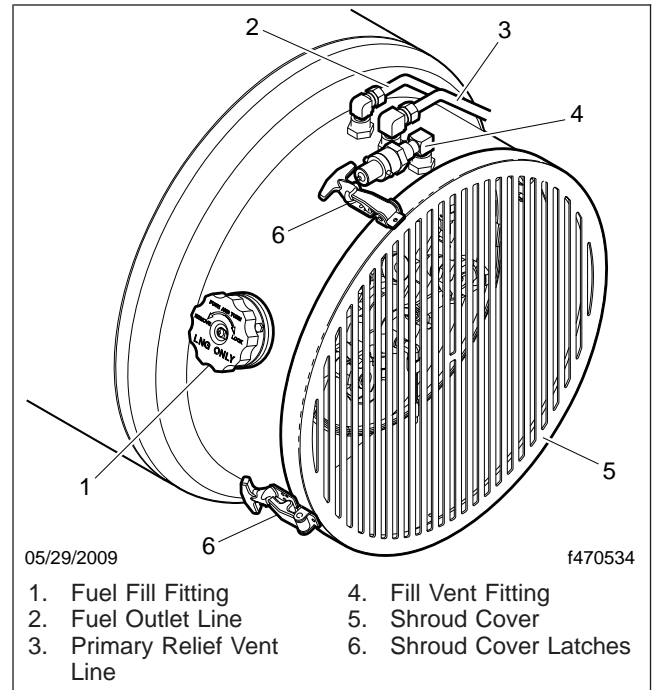

Fig. 19.2, LNG Fuel Tank

erated in approximately ten days, is considered to be a hot tank. When fueling a hot tank, LNG entering the tank will immediately vaporize, causing tank pressure to spike above 250 psi (1724 kPa) and automatically shutting down the station fuel pump. To prevent the pump from shutting down, connect a vent line to the fill vent fitting on the LNG tank to capture escaping vapor, then open the shroud cover and open the vapor shutoff valve ([Fig. 19.3](#), Item 2).

6. Open the station's fill valve, if equipped, and start fueling. Monitor the flow or line pressure as filling progresses. When filling begins, line pressure will spike quickly until the vehicle tank cools down. The flow and pressure will then remain stable during the remainder of the filling procedure.

IMPORTANT: When fueling a hot tank, initially put 5 to 10 gallons (19 to 37 liters) of LNG in the tank and manually stop the fueling process. Drive the vehicle for 15 to 20 minutes to cool the tank and reduce tank pressure, then continue fueling the tank to full.

Natural Gas Vehicle

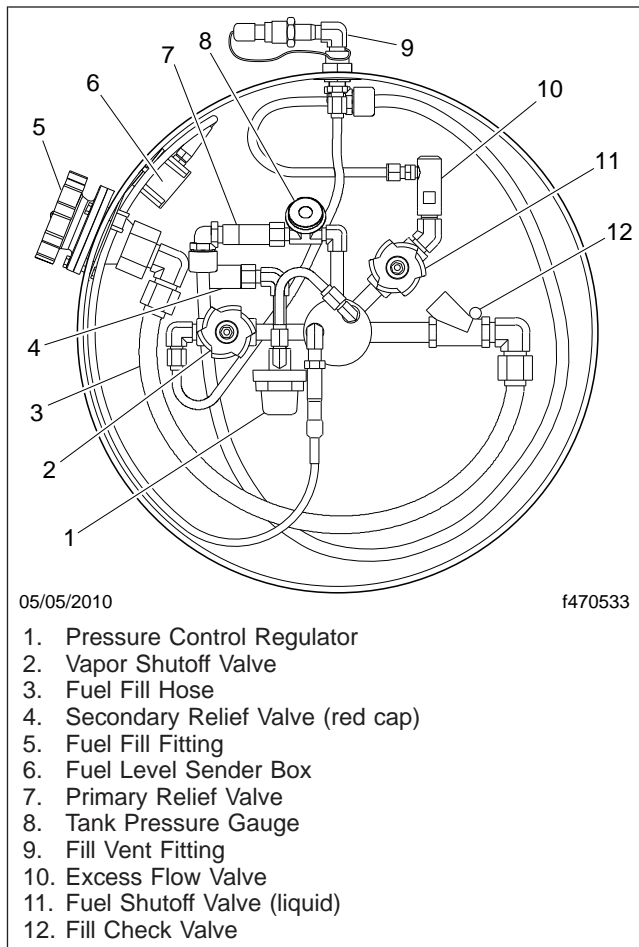

Fig. 19.3, LNG Fuel Tank Plumbing Components

7. When the tank is full, the line pressure will rapidly spike and the flow rate will fall. When a pressure rise or flow rate drop is observed, close the station's fill valve, if equipped.

NOTE: Do not over-fill an LNG tank. If the ullage tank is completely filled during fueling, tank standby time will be reduced to zero and the primary relief valve will open almost immediately after fueling.

8. Disconnect the station hose from the tank fuel fill fitting.
9. Disconnect the electrical ground clamp and cable from the fuel tank.
10. Install the dust cap on the tank fuel fill fitting.

Natural Gas Detection System

A gas detection system is standard equipment in all Daimler Trucks natural-gas-fueled vehicles. This system has a sensor in the engine compartment and one in the cab, both situated in high areas to detect natural gas buildup as a result of leaks.

The AMGaDS III Plus is a natural gas detection system. This device is meant to serve as a supplemental warning only. It is not intended to replace standard safety practices that should be conducted around flammable gases.

IMPORTANT: To function properly, the gas detection system must be powered at all times. The gas detection system is directly powered by the batteries, and can only be powered off by disconnecting the batteries. When servicing a natural-gas-fueled vehicle, disconnect the batteries only when necessary, and do not leave the batteries disconnected for extended periods of time.

The lower flammability limit (LFL) is the smallest amount of the gas that supports a flame when mixed with oxygen and ignited. Zero percent (0%) LFL indicates a gas-free atmosphere. One hundred percent (100%) LFL indicates that gas concentration has reached its lower flammability limit (5% gas in air by volume). The red warning light and audible alarm located in the overhead console activate when a sensor detects gas fumes in concentrations above 50% LFL, and should allow ample time to utilize safety procedures. However, individuals with special needs should review the system with a professional safety engineer.

Alarm Procedure

Before operating the vehicle, the driver must be familiar with the procedures as shown on the interior sticker on the overhead panel (**Fig. 19.4**) and the exterior sticker on the door (**Fig. 19.5**).

IMPORTANT: If an audible alarm activates, do not operate any electrical switch, including lights. Avoid causing sparks and stay away from arcing switches and equipment. Do not use a telephone, including cellular phones or any types of portable communication or electronic devices that have a battery.



Fig. 19.4, Interior Warning Sticker



Fig. 19.5, Exterior Warning Sticker

If the vehicle is in motion when the audible alarm activates, bring it to a safe stop, shut down the engine, and exit the vehicle. *Do not open the hood.*

If outside the vehicle when the audible alarm activates, *do not open the cab door or hood.*

In the event of an audible alarm, immediately follow these procedures, as allowed by conditions:

1. Immediately shut off all engines. Extinguish any cigarettes, pilot lights, flames, or other sources of ignition in the area and adjacent areas.
2. Manually close all fuel shutoff valves, including those on the LNG tank or CNG cylinders.
3. If the vehicle is indoors (as in a service shop), immediately open windows and doors to provide extra ventilation to the area. Do not start the engine or any other type of equipment until the gas leak is corrected and the area cleared of natural gas.
4. Evacuate the area.
5. Check the fuel lines, LNG tank/CNG cylinders, and fittings to locate the leak. After the area is cleared of natural gas and the alarm is no longer active, have the vehicle inspected by a qualified technician.

IMPORTANT: Do not consider the area clear until all alarm indicators are off, and the alarm panel light returns to green.

Sensors

Gas detection sensors are located on the cab overhead console and in the engine compartment on the frontwall. The sensors are located in high areas, where rising gas vapors will pass by or accumulate.

If the system detects that one of the sensors has been disconnected or has malfunctioned, the sensor fault light for that zone will illuminate. A failed sensor may trigger and lock on an alarm. If a fault condition or locked alarm continues after the sensor's connection and wiring integrity has been verified, replace the sensor.

The sensors are sensitive to all hydrocarbon vapors. An alarm may be triggered by the use of chemicals such as cleaners, paint, polish, lacquer, gasoline, silicone, silicone spray, or other harsh chemicals. The sensors will also detect hydrogen fumes from an overcharged battery. If a sensor sends an alarm, but no gas fumes are present, check for recent use of chemicals or a battery charger.

Natural Gas Vehicle

NOTICE

Silicone-based chemicals and cleaners will permanently disable the sensors. When cleaning the vehicle, cover the sensors with a plastic covering. Keep the sensors covered until the area has been cleared of any cleaning fumes.

Harsh chemicals and extremely high temperatures may damage the sensor.

Puncture of or damage to the seal located inside the sensor housing will significantly shorten the sensor life.

Frequent exposure to high concentrations of gas will accelerate sensor deterioration.

Overhead Console

The overhead console consists of an alarm panel on the right side and the control module on the left side.

The alarm panel has a green light, a red light, a buzzer, and a sensor. See [Fig. 19.6](#). It is located within view from outside of the vehicle. The large green light is continuously illuminated during normal operating conditions.

Before entering the vehicle, always verify that the green light is illuminated. If the green light is not illuminated, do not enter the vehicle. Complete the alarm procedure previously outlined.

The alarm panel meets the California Highway Patrol Title 13-2008 and NFPA 52 2010 requirements. All drivers and technicians using it should be trained regarding the red and green lights, and the audible warning.

The control module, located on the left side of the overhead console, contains the status lights and control buttons for the system. The areas that the sensors monitor are defined as Zone 1 (cab) and Zone 2 (engine compartment). The control module has lights assigned to each zone that will illuminate if a sensor detects a trace level leak (between 20% and 30% LFL), a significant level leak (above 50% LFL), or if a sensor is disconnected or malfunctioning.

- **Trace Level:** If either sensor detects gas fumes at a concentration greater than 20% to 30% LFL (1% gas in air by volume), the amber light next to the *Trace* indicator for that zone will flash. There is no buzzer alarm for a trace

level detection, and the large green light on the alarm panel will remain illuminated.

- **Significant Level:** If either sensor detects gas fumes at a concentration greater than 50% to 60% LFL (2.5% gas in air by volume), the small red light next to the *SIGNIFICANT* indicator for that zone will flash. After approximately 15 seconds, the large green light on the alarm panel will switch off, the red light will illuminate, and the buzzer will sound. All alarm indicators will remain on as long as fumes are detected.
- **Sensor Fault:** If the system detects that either of the sensors has been disconnected or has malfunctioned, an amber light next to the *Sensor Fault* indicator for that zone will illuminate.

The control module also has buttons used to test or reset the the control module after an alarm. Red lights next to each button indicate when they are engaged.

- **Shutdown Reset:** If an alarm has been activated and the *Relay Engaged* light is illuminated, the *Shutdown Reset* button will reset the internal relay. Press the *Shutdown Reset* button only after the gas has cleared, the buzzer has turned off, and the alarm panel light has returned to green.
- **Push To Silence:** If an alarm has been activated, the *Push To Silence* button will silence the buzzer.

See [Table 19.2](#) for the functions of all lights and buttons on the overhead console.

Testing

Daimler Trucks North America strongly recommends that all operators follow California Code of Regulations (CCR) inspection requirements, regardless of where the vehicle is operated. Per Title 13 CCR § 935 (2), gas detection systems should be tested three times per calendar year at equal intervals. The testing procedure should simulate the same operating environment in which the vehicle is used, with the same gaseous fuel.

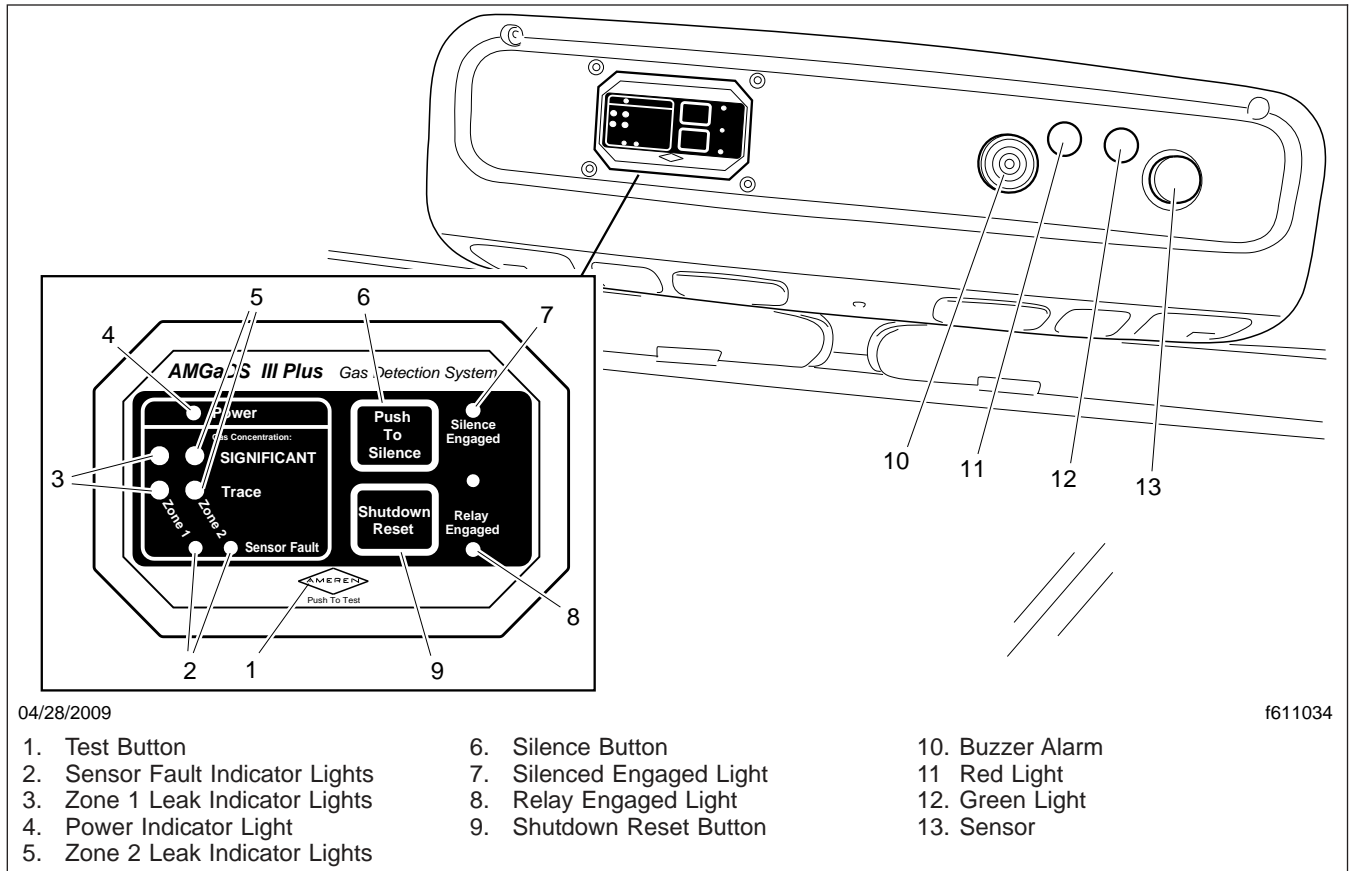

04/28/2009

f611034

- | | | |
|----------------------------------|---------------------------|------------------|
| 1. Test Button | 6. Silence Button | 10. Buzzer Alarm |
| 2. Sensor Fault Indicator Lights | 7. Silenced Engaged Light | 11. Red Light |
| 3. Zone 1 Leak Indicator Lights | 8. Relay Engaged Light | 12. Green Light |
| 4. Power Indicator Light | 9. Shutdown Reset Button | 13. Sensor |
| 5. Zone 2 Leak Indicator Lights | | |

Fig. 19.6, AMGaDS III Plus Overhead Console

Control Module Functions			
Item	Display	Function	Action Required
Green Power Light	Illuminated	System is on.	None required.
	Unlit	Detection system is not functioning.	Ensure the batteries are connected and replace any blown fuses. If the gas detection system is still not functioning, replace the system immediately.
SIGNIFICANT Gas Concentration Lights	Red (illuminated)	Dangerous gas concentration detected.	Suspend vehicle operation immediately and follow alarm procedures.
Trace Gas Concentration Lights	Amber (flashing)	Minor gas concentration detected.	Use caution and monitor the system.
Sensor Fault Lights	Off	Sensor is functioning properly.	None required.
	On	Sensor has malfunctioned.	Replace the sensor immediately.

Natural Gas Vehicle

Control Module Functions			
Item	Display	Function	Action Required
Shutdown Reset Button	—	Resets the system after an alarm activation.	Press to reset the system only after the gas has cleared, the buzzer has turned off, and the alarm panel light has returned to green.
Relay Engaged Light	On	Relay is engaged and test or alarm is being cleared.	Press the <i>Shutdown Reset</i> button.
	Off	Normal condition.	None required.
Test Button	—	Tests the overhead console operation and circuitry.	Press and hold for one minute to activate a test of all overhead console components.
Silence Button	—	Silences the alarm buzzer.	Press to silence the alarm buzzer.
Silence Engaged Light	On	Indicates the buzzer is active but silenced.	Suspend vehicle operation immediately and follow alarm procedures.
	Off	Normal condition.	None required.

Table 19.2, Control Module Functions

Test results validating the performance of the gas detection system within the parameters established by the component manufacturer and NFPA 52 2010 should be maintained as a permanent part of the vehicle service records. Use of alcohol, propane, and other harsh liquids or gases are not acceptable methods for testing.

Always test the system and sensors after any component has been replaced, or if the vehicle has been involved in an accident or fire. Ensure that the gas detection system is wired directly to the battery.

It is recommended that the highest level of safety validation be utilized if there are multiple validation requirements in the state or locality where the vehicle is operated or domiciled.

Overhead Console Test

Press and hold the *Push To Test* button for one minute. The system will proceed with a self-diagnostic test that will include illumination of the *Trace* and *SIGNIFICANT* gas concentration lights, and the sensor fault lights. Verify the large red light and buzzer activate, and that all lights illuminate or flash to ensure that all bulbs are operational.

Sensor Test

The gas detection system sensors must be tested using certified test gas, which can be purchased as part of a test kit. Testing with alcohol or heavy gases

such as butane or propane does not satisfy CCR § 935 (2) or NFPA 52 regulations.

Expose each sensor to certified test gas for at least thirty seconds. The system will proceed through the alarm procedure consistent with a significant leak and the buzzer will sound after approximately fifteen seconds. If a sensor fails to respond after exposure to the test gas, replace the sensor.

Natural Gas Vehicles, Engine Starting

NOTE: Before starting the engine, read [Chapter 4](#) for detailed information on how to read the instruments and [Chapter 5](#) for detailed information on how to operate the controls. Read the operating instructions in the engine manufacturer's operation manual before starting the engine.

1. Before engine start-up, complete the engine pre-trip and post-trip inspections and maintenance procedures in [Chapter 20](#) and [Chapter 21](#).
2. Ensure the fuel shutoff valve is open.
3. Set the parking brake.
4. Ensure that the transmission shift control is in Neutral (N), Park (P), or the Park Brake (PB) position.

- Without starting the engine, turn the ignition switch to the ON position (**Fig. 19.7**). The electronic gauges on the instrumentation control unit (ICU) will complete a full sweep of their dials, the warning and indicator lights will illuminate, and the buzzer will sound for three seconds.

Replace any leaking or damaged fuel tanks/cylinders and fuel lines; repair or replace leaking or damaged fittings. Install parts and components in accordance with the manufacturer's instructions.

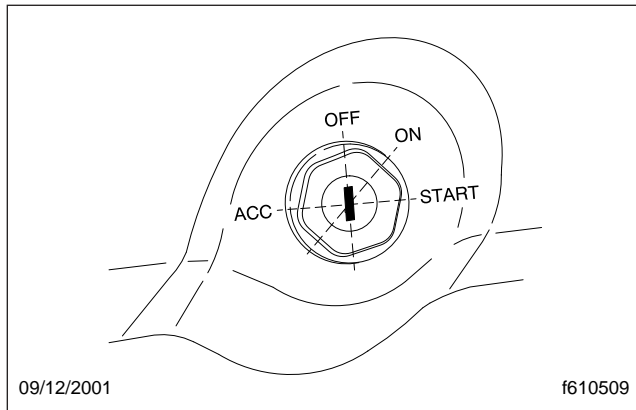

Fig. 19.7, Ignition Switch Positions

- Turn the ignition switch to the START position.
Press down on the clutch pedal, if equipped, but do not press down on the accelerator pedal.
Release the key the moment the engine starts.
- Bring the engine up to operating speed gradually as it warms up and develops stable oil pressure. If the vehicle has not been operated previously in a 24-hour period, allow the vehicle to idle for five minutes.

NOTICE

Do not rev the engine if the oil pressure gauge indicates no oil pressure. Shut down the engine within approximately ten seconds to avoid engine damage.

- Check the oil pressure gauge for any drop in lubricating oil pressure or mechanical malfunction in the lubricating oil system.

Major Repair and Replacement of Natural Gas Components

If a natural-gas-fueled vehicle is involved in an accident, remove the fuel tank or cylinders from service and have them inspected by a qualified technician.

20

Pre- and Post-Trip Checklists

Periodic Inspections and Maintenance	20.1
Checklists	20.1
Fluids Added	20.2

Pre- and Post-Trip Checklists

Periodic Inspections and Maintenance

Regulations in Canada and the U.S. clearly indicate that it is the driver's responsibility to perform an inspection, and ensure the complete road-worthiness of a vehicle, before placing it into service. Commercial vehicles may be subject to inspection by authorized inspectors, and an unsafe vehicle can be taken "out of service" until the driver or owner repairs it.

Use the following checklists to ensure that vehicle components are in good working condition before each trip. Careful inspections eliminate stops later to fix overlooked or forgotten items.

The checklists in this chapter can be copied and kept as a record that the procedures have been completed. For details on how to inspect each item on the checklists, see the corresponding procedure (step number) in [Chapter 21](#).

Checklists

NOTE: Checklists in this chapter correspond with the procedures and steps in [Chapter 21](#), *Pre- and Post-Trip Inspections and Maintenance*. Your vehicle may not be equipped with all components listed below.

Daily Pretrip Inspection Checklists

See the following tables for a list of procedures that should be performed daily, before the first trip. Place a check mark in the complete (**Comp.**) column to indicate a procedure has been performed.

Inspector	Date

Suspension and Slack Adjusters		Comp.
1	Suspension components	
2	Slack adjusters	

Wheels and Tires		Comp.
1	Wheel covers	
2	Tire condition	
3	Tire inflation	
4	Rims and wheel components	
5	Wheel bearing oil seals and lubrication levels	
6	Mud Flaps	

Saddle Tank Areas		Comp.
1	Drain air reservoirs (without automatic drain valves)	
2	Fuel tank(s) secure	
3	Frame rails and crossmembers	
4	Visible exhaust components	

Engine Compartment		Comp.
1	Leakage under engine	
2	Air intake system	
3	Engine oil level	
4	Power steering reservoir level	
5	Engine coolant level	
6	Visible engine wiring	
7	Frame rails	

Cab		Comp.
1	Reset dash-mounted air intake restriction indicator	
2	Air-pressure warning systems	
3	Air governor cut-in and cut-out pressures	
4	Air pressure build-up time	
5	Air system leakage	
6	Air pressure reserve	
7	Mirrors, windows, windshield	
8	Horn, windshield wipers, windshield washers	
9	Heater and defroster	
10	Interior lights	
11	Exterior lights	
12	Seat belts and tether belts	
13	Fuel level	
14	Mirror adjustment	
15	Service brakes	
16	Backup alarm	

Natural Gas Fuel System Inspection		Comp.
1	Fuel tanks	
2	Required decals	
3	Vent caps	
4	Plumbing components, fuel fill fitting, fuel lines	
5	Fuel gauge components, LNG fuel tank pressure	
6	Coolant hoses	
7	LNG fuel tank pressure	
8	LNG vaporizer	

Pre- and Post-Trip Checklists

Weekly Post-trip Inspection Checklist

See the following table for procedures that should be performed weekly, post-trip. Place a check mark in the complete (**Comp.**) column to indicate a procedure has been performed.

Inspector	Date

Engine Compartment		Comp.
1	Windshield washer reservoir level	
2	Air intake restriction indicator	
3	Water evacuation components	
4	Automatic transmission fluid level	
5	Water in fuel/water separator	
6	Steering components	
7	Serpentine drive belts	

Monthly Post-trip Inspection Checklists

See the following tables for procedures that should be performed monthly, post-trip. Place a check mark in the complete (**Comp.**) column to indicate a procedure has been performed.

Inspector	Date

Brake Components		Comp.
1	Brake system components	
2	Brake chambers	
3	Air brake lines	
4	Flex air hoses	
5	Brake linings and brake drums	
6	Brake lining thickness	

Saddle Tank Areas		Comp.
1	Drain air reservoirs (with automatic drain valves)	
2	Batteries (location may vary)	
3	Aerodynamic components	

Engine Compartment		Comp.
1	Hood and bumper	
2	Hydraulic clutch reservoir	
3	Radiator and heater hoses	
4	Steering wheel play	

Natural Gas Fuel System		Comp.
1	System leak test	
2	Drain CNG high-pressure fuel filter housing	

Fluids Added

Use the following table to note any fluids that were added during the inspection and maintenance procedures.

Fluids Added During Inspection	
Fluid	Amount Added
Wheel Bearing Lubricant	
Engine Oil	
Power Steering Fluid	
Engine Coolant	
Windshield Washer Fluid	
Automatic Transmission Fluid	
Hydraulic Clutch Fluid (DOT 4 brake fluid)	

21

Pre- and Post-Trip Inspections and Maintenance

Daily Pretrip Inspection and Maintenance	21.1
Weekly Post-Trip Inspection and Maintenance	21.9
Monthly Post-Trip Inspection and Maintenance	21.11

Pre- and Post-Trip Inspections and Maintenance

Daily Pretrip Inspection and Maintenance

Complete the following inspection and maintenance procedures to ensure that vehicle components are in good working condition before each trip. A driver who is familiar with the vehicle and drives it regularly can perform the daily inspections, then add the weekly and monthly post-trip inspections as scheduled.

If the driver does not operate the vehicle on a consistent basis, all daily, weekly, and monthly inspection and maintenance procedures should be performed before the trip.

IMPORTANT: The pre- and post-trip checklists, inspections, and maintenance procedures detailed in this chapter are **not all-inclusive**. Refer to other component and body manufacturers' instructions for specific inspection and maintenance instructions, as well as local, state, and federal guidelines.

NOTE: If any system or component does not pass this inspection, it must be corrected before operating the vehicle. Whenever equipment requires adjustment, replacement, and/or repair, see the *108SD and 114SD Workshop Manual* for procedures and specifications.

Suspension and Slack Adjuster Inspection

Walk around the vehicle and visually inspect suspension and slack adjuster components.

1. Inspect the following suspension components for signs of structural damage, cracks, or wear.
 - springs
 - spring hangers
 - shocks
 - suspension arms
 - suspension brackets
 - axle seats
 - bushings
2. Inspect slack adjusters for signs of damage. See [Fig. 21.1](#), [Fig. 21.2](#), or [Fig. 21.3](#).

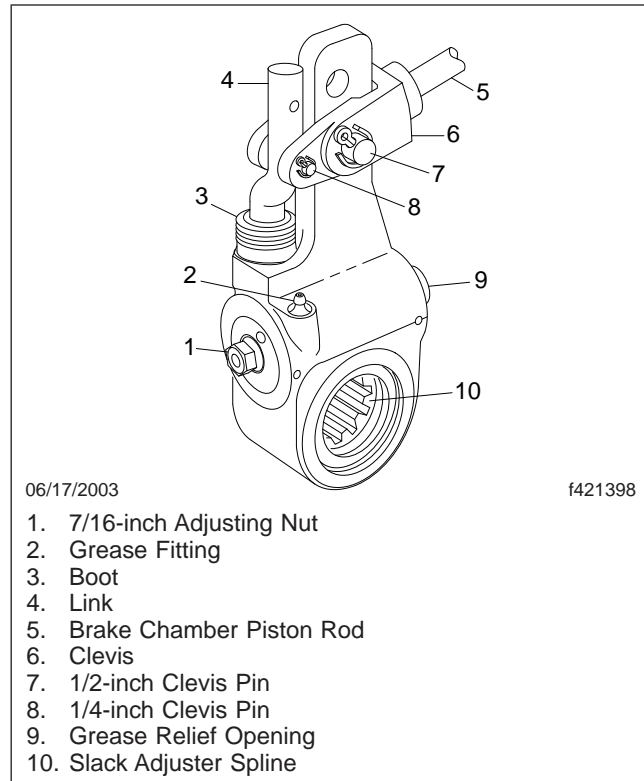

Fig. 21.1, Gunite Automatic Slack Adjuster

- Inspect slack adjuster boots, if equipped, for cuts or tears.
- Inspect anchor straps, if equipped, for damage.
- Look for worn clevis pins on brake chamber pushrods.
- Look for missing or damaged cotter pins on the clevis pins.
- Ensure chamber piston rods are in line with the slack adjusters.

Wheel and Tire Inspection

Walk around the vehicle and visually inspect each wheel and tire assembly.

IMPORTANT: Wheel covers decrease drag force as a vehicle moves, thereby improving fuel efficiency. If replacement of a wheel cover is necessary, the replacement cover must meet or exceed the drag reduction performance of the

Pre- and Post-Trip Inspections and Maintenance

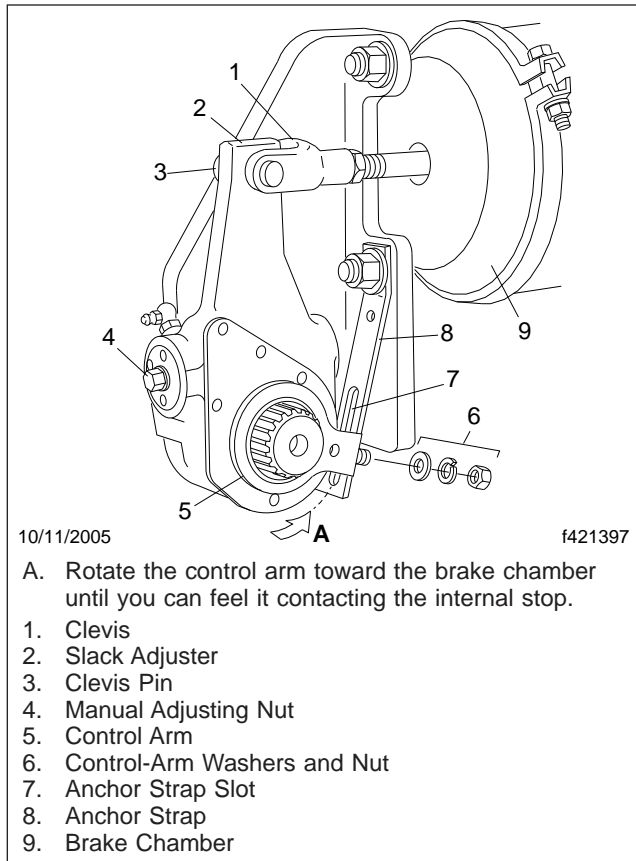

Fig. 21.2, Haldex Automatic Slack Adjuster

originally installed cover in order to maintain compliance with greenhouse gas and full efficiency regulations (GHG14).

1. If the vehicle was originally equipped with wheel covers, ensure all wheel covers are present. Inspect wheel covers for damage or wear. Remove wheel covers from rear drive wheels, if equipped, prior to inspecting the tires and wheel components.

NOTE: During wheel cover installation, ensure the V-notch in the liner inner retaining ring is centered on the valve stem. The inner and outer retaining rings should be uniformly aligned to each other and to the wheel rim. The outer retaining ring of the liner is equipped with two canvas flaps. When installing the face cover, make sure the cover retaining ring is inserted between the two canvas flaps on the liner outer

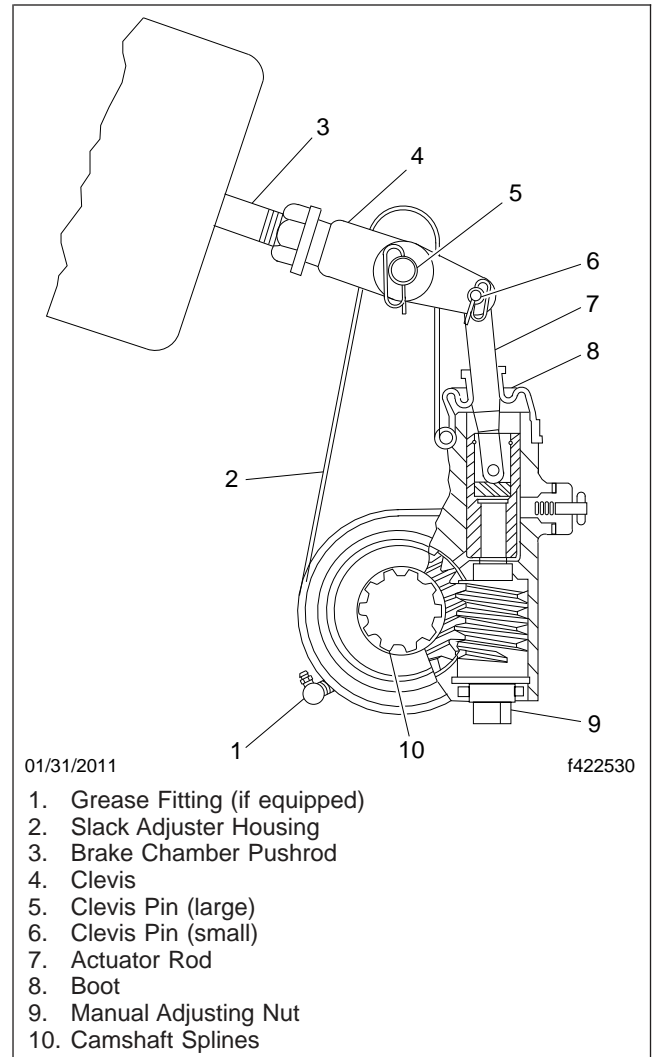

Fig. 21.3, Meritor Automatic Slack Adjuster

retaining ring so that the Velcro strips line up between the face cover and the liner. Make certain the detachable view cover is centered on the face cover, and the Velcro strips are pressed firmly in place.

2. Inspect each tire for the following:
 - valve stem caps on every tire, screwed on finger-tight
 - bulges, cracks, cuts, and penetrations
 - oil contamination (petroleum derivatives will soften the rubber and destroy the tire)

Pre- and Post-Trip Inspections and Maintenance

- tread depth—if tread is less than 4/32 inch (3 mm) on any front tire, or less than 2/32 inch (1.5 mm) on any rear tire, replace the tire
- debris lodged between dual tire sets

IMPORTANT: Low-rolling resistance (LRR) tires minimize wasted energy as a tire rolls, thereby decreasing rolling effort and improving fuel efficiency. If tire replacement is necessary, replacement tires must meet or exceed the rolling resistance of the originally installed tires in order to maintain compliance with greenhouse gas and full efficiency regulations (GHG14).

Contact your tire manufacturer/supplier to determine the rolling resistance of the originally installed tires. Visit www.epa.gov/smartway for additional information and resources.

WARNING

Do not operate the vehicle with underinflated or overinflated tires. Incorrect inflation can stress the tires and make the tires and rims more susceptible to damage, possibly leading to rim or tire failure and loss of vehicle control, resulting in serious personal injury or death.

3. Check tire inflation.

For inflation pressures and maximum loads, see the tire manufacturer's guidelines. Inflate the tires to the applicable pressures if needed.

If a tire has been run flat or under-inflated, check the wheel and tire for damage before adding air.

Keep compressed air reservoirs and lines dry during tire inflation. Use well-maintained inline moisture traps and service them regularly.

NOTICE

A weekly pressure loss of 4 psi (28 kPa) or more in a tire may indicate damage. The tire should be inspected and, if necessary, repaired or replaced by a qualified tire service facility.

IMPORTANT: The load and cold inflation pressure must not exceed the rim or wheel manufacturer's recommendations, even though the tire may be approved for a higher load inflation.

Consult the rim or wheel manufacturer for the correct tire inflation pressure for the vehicle load.

4. Examine each rim and wheel component. Check the wheel nuts or rim nuts for indications of looseness.
 - 4.1 Remove all dirt and debris from the assembly. Rust streaks or metal build-up around stud holes, or out-of-round or worn stud holes, may be caused by loose wheel nuts.

WARNING

Have any worn or damaged wheel components replaced by a qualified person using the wheel manufacturer's instructions and the wheel industry's standard safety precautions and equipment. Otherwise a vehicle or workshop accident could occur, possibly resulting in serious personal injury or death.

- 4.2 Inspect for broken, cracked, badly worn, bent, rusty, or sprung rings and rims.

NOTICE

Use the recommended torque values and follow the proper tightening sequence. Insufficient wheel nut torque can cause wheel shimmy, resulting in wheel damage, stud breakage, and extreme tire tread wear. Excessive wheel nut torque can break studs, damage threads, and crack discs in the stud hole area.

- 4.3 Make sure all wheel nuts are tightened. If tightening is necessary, use the tightening pattern in [Fig. 21.4](#) or [Fig. 21.5](#).
5. Inspect the outboard side of all wheel hubs and the hub oil seal area on the inboard side of each wheel for signs of oil leakage. If any oil is found on wheel and tire or brake components, remove the vehicle from service until the leak has been fixed.

If needed, fill the hubs to the level indicated on the hub cap. See **Group 35** of the *108SD and 114SD Maintenance Manual* for recommended lubricants.
6. Check that mud flaps are undamaged and hang 10 inches (25.4 cm) or less from the ground.

Pre- and Post-Trip Inspections and Maintenance

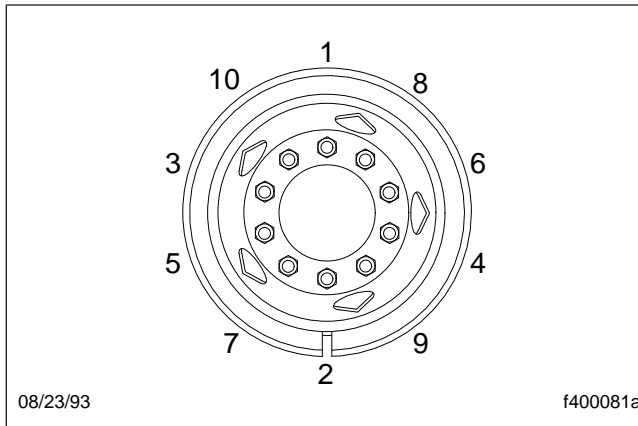

Fig. 21.4, Tightening Pattern, 10-Hole Wheels

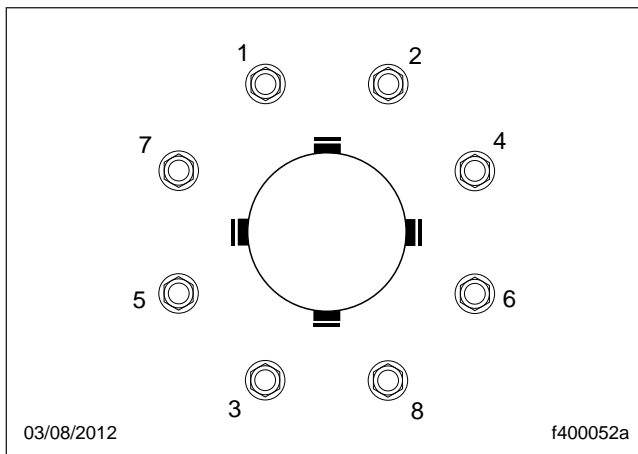

Fig. 21.5, Tightening Pattern, 8-Hole Wheels

Saddle Tank Areas Inspection

WARNING

When draining the air reservoir, do not look into the air jets or direct them toward anyone. Dirt or sludge particles may be in the airstream and could cause injury.

NOTICE

If the water drained from the air reservoirs is cloudy or oily, it may indicate a problem with the compressor. If oil is allowed to contaminate the air dryer, it will not remove the water from the air brake system, which could adversely affect braking.

1. Drain the brake system air reservoirs (reservoirs without automatic drain valves only).
2. Ensure fuel tanks are secured to their mounting brackets and that the mounting brackets are secured to the frame.
3. Inspect visible frame rails for missing bolts, shiny areas, or rust streaks. Check all visible cross-members for damage or signs of looseness.
4. Inspect visible components of the exhaust system to ensure connections are tight.

Inspect upstream of the aftertreatment device (ATD) for cracking or signs of leaks, such as soot trails. Inspect downstream of the ATD for signs of exhaust leaks, such as blistering or warping of nearby components.

Engine Compartment Inspection

1. Check the ground underneath the engine for fuel, oil, or coolant leaks.
2. Inspect the air intake system for leaks or damage.

NOTICE

Failure to maintain a sealed air intake system could allow the entry of dirt and contaminants into the engine. This could adversely affect engine performance and result in engine damage.

- 2.1 Push the reset button on the air intake restriction indicator located on the air cleaner, if equipped.
 - 2.2 Check the engine air intake duct from the air cleaner to the engine intake. Make sure the duct components are secure and airtight.
 - 2.3 Check the vacuator (spitter) valve(s) for damage, and make sure the lips of the valve are pliable and free of debris.
3. Check the engine oil level.

NOTICE

Operating the engine with the oil level below the minimum fill (or "add") mark or above the maximum fill (or "full") mark could result in engine damage.

Pre- and Post-Trip Inspections and Maintenance

- 3.1 Check the oil level with the vehicle parked on a level surface. See the engine manufacturer's guidelines for engine shutdown time requirements prior to checking the oil level.

IMPORTANT: Vehicles domiciled in the U.S. or Canada require the use of CJ-4 engine oil with less than 1% sulfated ash. Failure to use CJ-4 oil may void the warranty on emission aftertreatment components.

- 3.2 If the oil level is at or below the minimum fill (or "add") mark on the dipstick, add enough oil to maintain the level between the minimum and maximum fill marks. See the engine operation manual for recommended lubricants.

For natural gas vehicles, use only Exxon Busgard® Geo 15W-40 natural gas engine oil.

4. Check the power steering reservoir fluid level.

The power steering fluid level should be between the MIN COLD mark and the middle mark just above it. See [Fig. 21.6](#). If needed, fill the reservoir with automatic transmission fluid that meets Dexron III or TES-389 specifications.

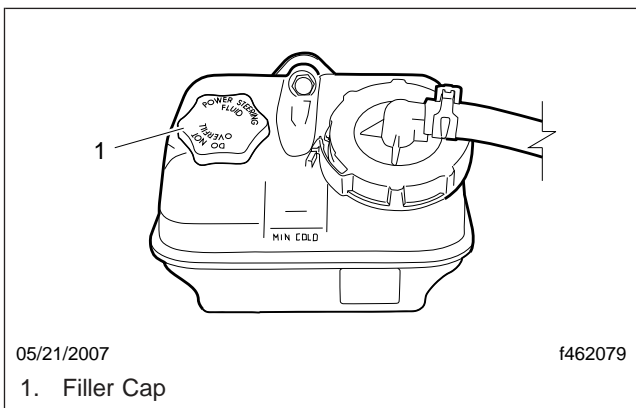

Fig. 21.6, Power Steering Fluid Reservoir

IMPORTANT: The surge tank must be cool to check the coolant level.

5. Check the engine coolant level in the radiator surge tank.

NOTICE

Coolant must be filled to the COLD MAX line of the surge tank. Low coolant could result in engine overheating, which could cause engine damage.

- 5.1 If the coolant is low, fill the surge tank to the MAX line with a 50/50 mixture of water and the type of antifreeze currently installed in your vehicle.

For natural gas vehicles, use only Fleet-guard ES Compleat™ EG Premix 50/50 engine coolant.

- 5.2 If the surge tank was empty, start the engine after refilling and check the level again when the engine is at operating temperature.

6. Inspect visible engine wiring for damage or looseness. See [Fig. 21.7](#).
7. Inspect visible frame rails for missing bolts, shiny areas, or rust streaks.

Cab Inspection

1. Push the reset button on the dash-mounted air intake restriction indicator, if equipped.
2. With the ignition switch in the OFF position, check the air-pressure warning system.
 - 2.1 If not previously drained, drain the air reservoirs using moderate brake applications until pressure in both reservoirs is less than 70 psi (483 kPa).
 - 2.2 Turn the ignition to the ON position. The ICU will complete a full gauge sweep and bulb check, and the warning buzzer will sound. Ensure the BRAKE AIR lamp remains illuminated and the warning buzzer continues to sound after the gauge sweep is complete.
3. Check air governor cut-in and cut-out pressures.
 - 3.1 Start the engine and ensure the BRAKE AIR lamp goes out and the buzzer silences when pressure reaches approximately 70 psi (483 kPa) in both air reservoirs.

Pre- and Post-Trip Inspections and Maintenance

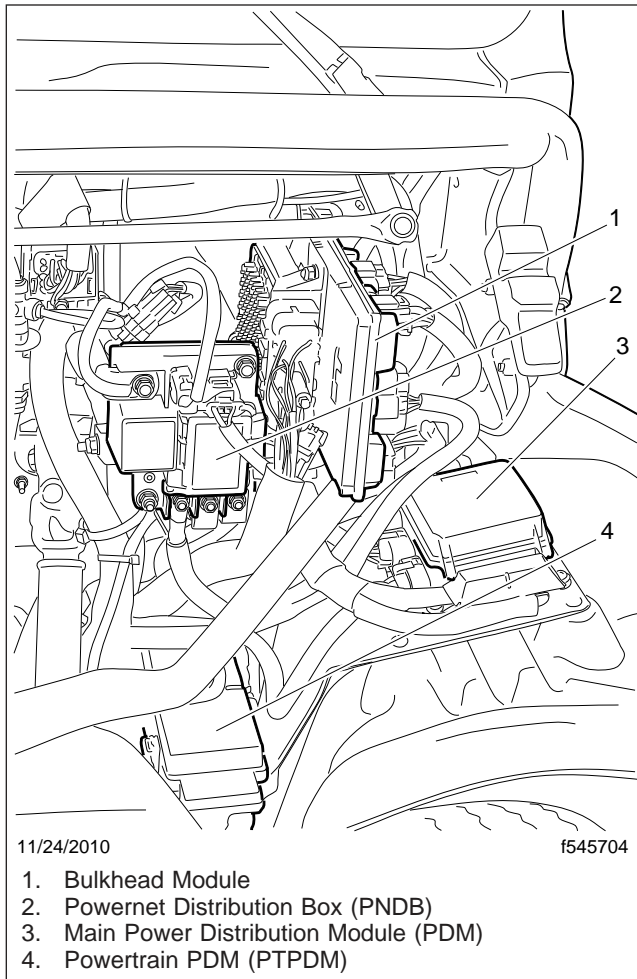

Fig. 21.7, Visible Engine Wiring

The air governor should cut out at approximately 120 psi (827 kPa). For vehicles with an optional dryer reservoir module (DRM), the cut-out pressure is approximately 130 psi (896 kPa).

- 3.2 With the engine idling, apply the brake pedal several times. The air governor should cut in when pressure in the primary air reservoir (top air gauge) reaches approximately 100 psi (689 kPa).
4. Check air pressure build-up time.
 - 4.1 With the air system fully charged, make one full brake application and note the air pressure reading on the primary air gauge.

- 4.2 Further reduce air pressure using moderate brake applications, then run the engine at governed rpm.
- 4.3 Note the time that the pressure reaches the previously noted reading on the primary air gauge, then note the time that the air pressure reaches cut-out pressure.
- 4.4 If it takes longer than 30 seconds to reach cut-out pressure after the primary air gauge passes the previously noted pressure (noted after one full brake application), eliminate any leaks or replace the air compressor before operating the vehicle.
5. Check air leakage in the system.
 - 5.1 With the parking brake applied, the transmission out of gear, and the air system fully charged, release the service brakes and shut down the engine.
 - 5.2 Wait one minute and note the air pressure drop in psi (kPa) per minute from the primary air reservoir.
If the pressure drop exceeds the limits shown in [Table 21.1](#), eliminate any leaks before operating the vehicle.
6. Check the air pressure reserve.
With the engine still off, make one full brake application and observe the pressure drop on the primary air gauge. If pressure drops more than 25 psi (172 kPa), eliminate any leaks before operating the vehicle.

Description	Maximum Allowable Air Leakage	
	Pressure Drop: psi (kPa) Per Minute	
	Released	Applied
Truck or Tractor Only	2 (14)	3 (21)
Truck or Tractor w/Single Trailer	3 (21)	4 (28)

Table 21.1, Maximum Allowable Air Leakage

7. Check for fault codes.
Turn the ignition switch to the ON position and check the instrumentation control unit (ICU3) for fault codes. Have any active fault codes serviced before operating the vehicle.
8. Inspect the mirrors, window glass, and windshield for cracks or other damage.

Pre- and Post-Trip Inspections and Maintenance

9. Ensure that the horn, windshield wipers, and windshield washers are operating properly. These devices must be in good working order for safe vehicle operation.
10. Ensure the heater and defroster are operating properly.
11. Check the operation of all interior lights.
 - 11.1 Turn on the headlights and leave them on. Ensure all equipped gauge bulbs illuminate in the dash message center.
 - 11.2 Ensure all equipped driver control switches illuminate.
 - 11.3 Ensure both turn signal indicator bulbs illuminate in the dash message center when the turn signal switch is activated.
12. Check the operation of all exterior lights. See **Fig. 21.8**.

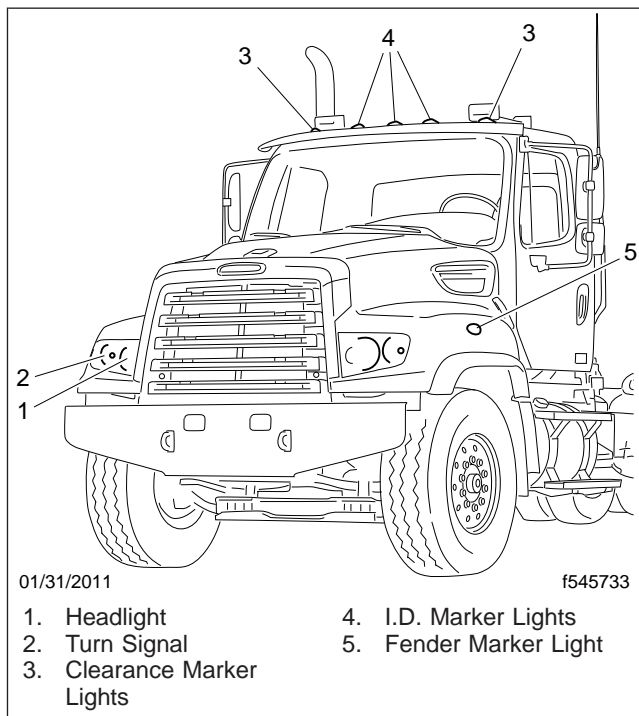

Fig. 21.8, Exterior Lights

- 12.1 Activate the high-beam headlights and hazard warning lights.
- 12.2 Exit the cab and check that all exterior lights and reflectors are clean and intact.

- 12.3 Check that the brake lights, taillights, headlights, turn signals, marker lights, identification lights, and clearance lights are working properly.

13. *Inspect the seat belts and tether belts.*

! WARNING

Inspect and maintain seat belts. When any part of a seat belt system needs replacement, the entire seat belt must be replaced, both retractor and buckle side. Any time a vehicle is involved in an accident, and the seat belt system was in use, the entire vehicle seat belt system must be replaced before operating the vehicle. Do not attempt to modify the seat belt system; doing so could change the effectiveness of the system. Failure to replace worn or damaged seat belts, or making any modifications to the system, may result in personal injury or death.

- 13.1 Check the web for fraying, cuts, extreme dirt and dust, or for severe fading from exposure to sunlight, especially near the buckle latch plate and in the D-loop guide area.
- 13.2 Check operation of the buckle, latch, Komfort Latch or Sliding Komfort Latch (if equipped), web retractor, and upper seat belt mount on the door pillar. Check all visible components for wear or damage.
- 13.3 Check the seat belt and tether belt connection points and tighten any that are loose.

IMPORTANT: Use ultralow-sulfur diesel (ULSD) with 15 ppm sulfur content or less. Failure to use ULSD fuel may void the warranty on emission components.

14. Check the fuel level in the fuel tank(s). To keep condensation to a minimum, fuel tanks should be filled at the end of each day.
15. Adjust the rearview and down view mirrors as necessary.
16. Test the service brakes.
 - 16.1 With the engine running and air system fully charged, set the parking brake.

Pre- and Post-Trip Inspections and Maintenance

16.2 Put the vehicle in the lowest gear and gently attempt to move it forward. The vehicle should not move.

If the vehicle moves, the parking brakes are not operating correctly and must be repaired before the vehicle is operated.

Natural Gas Fuel System Inspection, If Equipped

1. Inspect fuel tanks for dents, scratches, gouges, or other signs of damage. Inspect the fuel lines and connections for leaks.

Check that the fuel tanks are securely mounted. Look for signs of abrasion between components.

Compressed Natural Gas (CNG) Fuel System: Ensure that the CNG fuel cylinder storage box is secured to the frame. Inspect for signs of looseness.

Liquefied Natural Gas (LNG) Fuel System: Ensure that the LNG fuel tank is secured to the mounting brackets and that the mounting brackets are secured to the frame. Ensure all rubber isolator straps are secure around the LNG fuel tank.

2. Check for the presence of all required decals present in the following locations:
 - Gas detection system overhead console;
 - Above the door handle on both doors;
 - Left front bumper;
 - End-of-frame crossmember;
 - LNG fuel tank fill port (maximum psi), if equipped.
3. Check for the presence of vent caps on pressure relief valves and devices. If any caps are missing, have the fuel system inspected by a qualified technician.

CNG Fuel System: Each fuel cylinder should have two caps (one on each end), which are visible on the back of the CNG fuel cylinder storage box. One additional cap is located on the pressure relief valve on the inboard side of the CNG fuel box, next to the fuel outlet line.

LNG Fuel System: A red cap should be present on the secondary relief valve (**Fig. 21.9**).

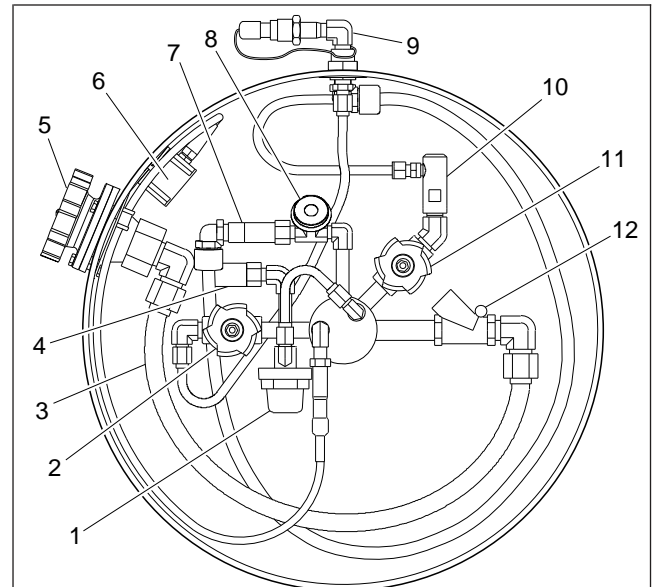

05/05/2010

f470533

1. Pressure Control Regulator
2. Vapor Shutoff Valve
3. Fuel Fill Hose
4. Secondary Relief Valve (red cap)
5. Fuel Fill Fitting
6. Fuel Level Sender Box
7. Primary Relief Valve
8. Tank Pressure Gauge
9. Fill Vent Fitting
10. Excess Flow Valve
11. Fuel Shutoff Valve (liquid)
12. Fill Check Valve

Fig. 21.9, LNG Tank Plumbing Components

4. Inspect all plumbing components, including the fuel shutoff valve(s), primary and secondary relief valves, and the LNG vapor shutoff and excess flow valves, if equipped, for signs of damage or leaks. See **Fig. 21.9** or **Fig. 21.10**.

Inspect the fuel fill fitting for signs of damage or leaks.

Inspect all lines for signs of leaks or damage, and check all threaded connections.

5. Inspect all fuel gauge components for signs of leaks or damage. Inspect the LNG fuel level sender cable and wiring, if equipped.
6. Inspect all coolant hoses for signs of chafing, kinks, or leaks. The LNG fuel system utilizes coolant hoses between the engine and the vaporizer; the CNG fuel system utilizes coolant

Pre- and Post-Trip Inspections and Maintenance

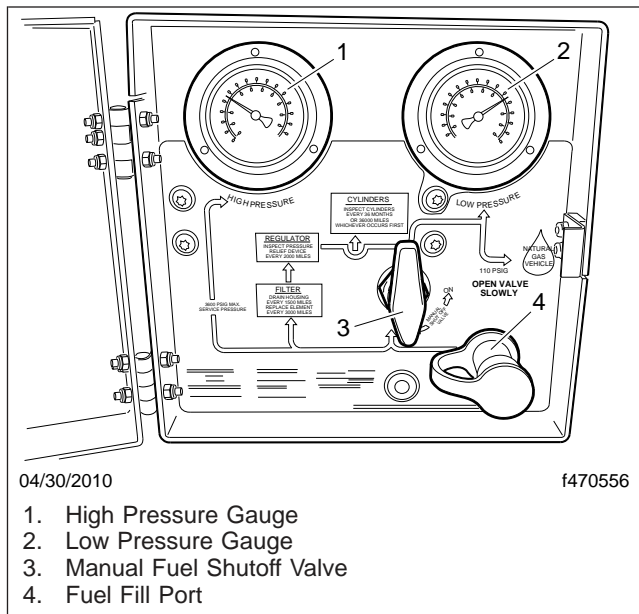

Fig. 21.10, CNG Fuel Panel

hoses between the engine and the pressure regulator inside the fuel panel.

7. If equipped with an LNG fuel system, check the fuel tank pressure gauge to ensure that pressure is within the normal range of 120 to 150 psi (827 to 1034 kPa). If tank pressure exceeds 230 psi (1586 kPa) and the pressure relief valve does not open automatically, vent the tank immediately.
8. Inspect the LNG vaporizer for signs of damage or leaks. See Fig. 21.11. Inspect the vaporizer mounting brackets for signs of looseness.

Weekly Post-Trip Inspection and Maintenance

Engine Compartment Inspection

WARNING

Washer fluids may be flammable and poisonous. Do not expose washer fluid to an open flame or any burning material, such as a cigarette. Always comply with the washer fluid manufacturer's recommended safety precautions.

1. Check the windshield washer reservoir fluid level. The reservoir is usually located near the right-hand frame rail.
2. After resetting the air intake restriction indicator during the daily pretrip inspection, check the indicator again with the engine off.
 - 2.1 Check an indicator with graduations to see if air restriction exceeds the value shown in Table 21.2.

Check a go/no-go indicator without graduations to see if the colored bar shows through the clear window.

Air Intake Restriction Values		
Engine Make*	Initial inH ₂ O	Maximum inH ₂ O
Cummins	12	25
Detroit Diesel	10	22

* Turbocharged engines must be checked at full load and governed engine speed.

Table 21.2, Air Intake Restriction Values

- 2.2 If air restriction exceeds the maximum allowable value, operate the vehicle for one more day, making sure not to run the engine over rated rpm. Refer to the engine operation manual for more information on rated rpm for your engine.
- 2.3 If air restriction exceeds the maximum value again, replace the air cleaner. For instructions, refer to **Group 09** of the *108SD and 114SD Workshop Manual*.
3. If the vehicle is equipped with an Allison automatic transmission, check the automatic transmission fluid level.
4. Check for water in the fuel/water separator, if equipped.
 - 4.1 Place a suitable container under the fuel/water separator. Many states now issue fines for draining fuel/water separators onto the ground.

NOTE: A hose may be used to direct water into the container. Use a hose with a ½-inch pipe thread on DAVCO models.

- 4.2 *Alliance/Racor Models:* Turn the drain plug counterclockwise to open it. See Fig. 21.12.

Pre- and Post-Trip Inspections and Maintenance

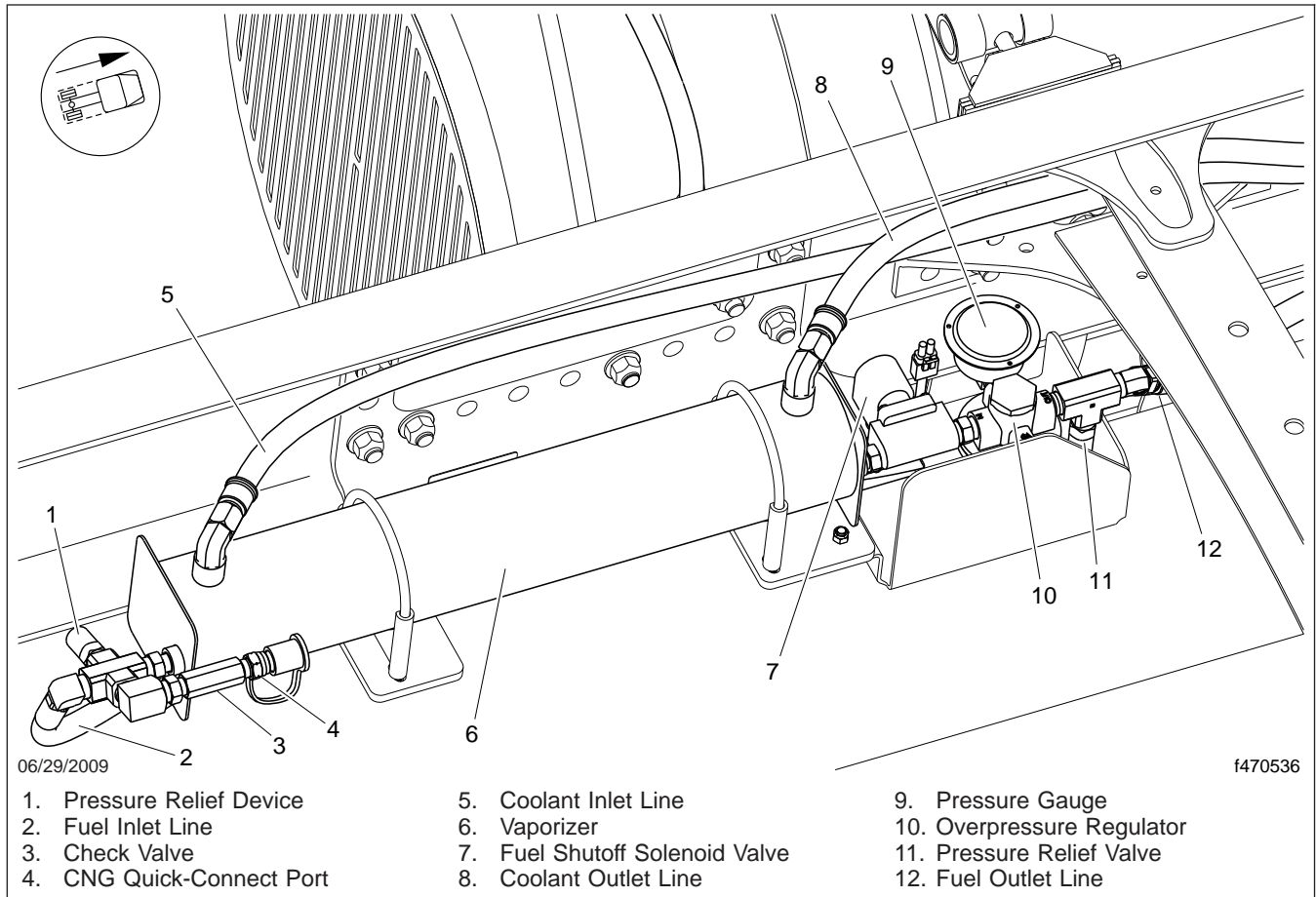

Fig. 21.11, LNG Vaporizer Assembly

- DAVCO Models:* Remove the vent cap and open the drain. See [Fig. 21.13](#).
- 4.3 Stop draining fluid when fuel begins to drain out.
- 4.4 *Alliance/Racor Models:* turn the drain plug clockwise to close it.
- DAVCO Models:* close the drain valve. Install and hand-tighten the vent cap.
5. Inspect the steering components. See [Fig. 21.14](#).
- 5.1 Inspect tie rods, steering arms, and the drag link for signs of looseness (i.e., shiny spots or rust tracks).
- 5.2 Check the steering gear mounting bolts and pitman arm nut for signs of looseness.
- 5.3 Check the drag link nuts for missing cotter pins.
- 5.4 Inspect the steering intermediate shaft and end yokes for excessive looseness or other damage.

NOTICE

Do not drive with a drive belt that is visibly worn or damaged. If it fails, the lack of coolant flow could rapidly cause damage to engine components.

Pre- and Post-Trip Inspections and Maintenance

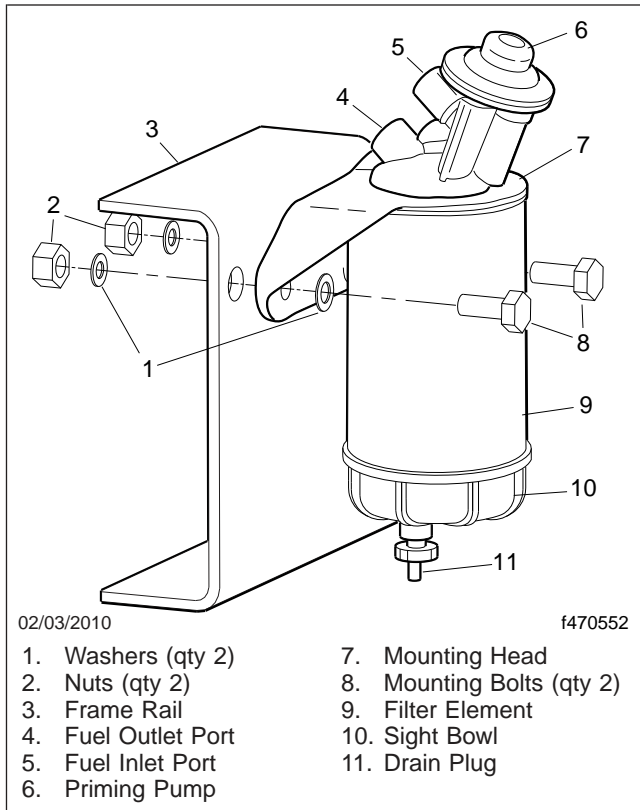

Fig. 21.12, Alliance Fuel/Water Separator Assembly and Installation

6. Inspect the serpentine drive belts for signs of glazing, frayed edges, breaks, cracks, or oil contamination.

Monthly Post-Trip Inspection and Maintenance

Brake Component Inspection

Walk around the vehicle and visually the brake system components for visible damage.

1. Inspect all visible brake system components for missing fasteners or signs of looseness, such as rust tracks.

NOTICE

If the external breather tube or breather cap is missing or incorrectly installed, road dirt and debris can adversely affect the operation of the

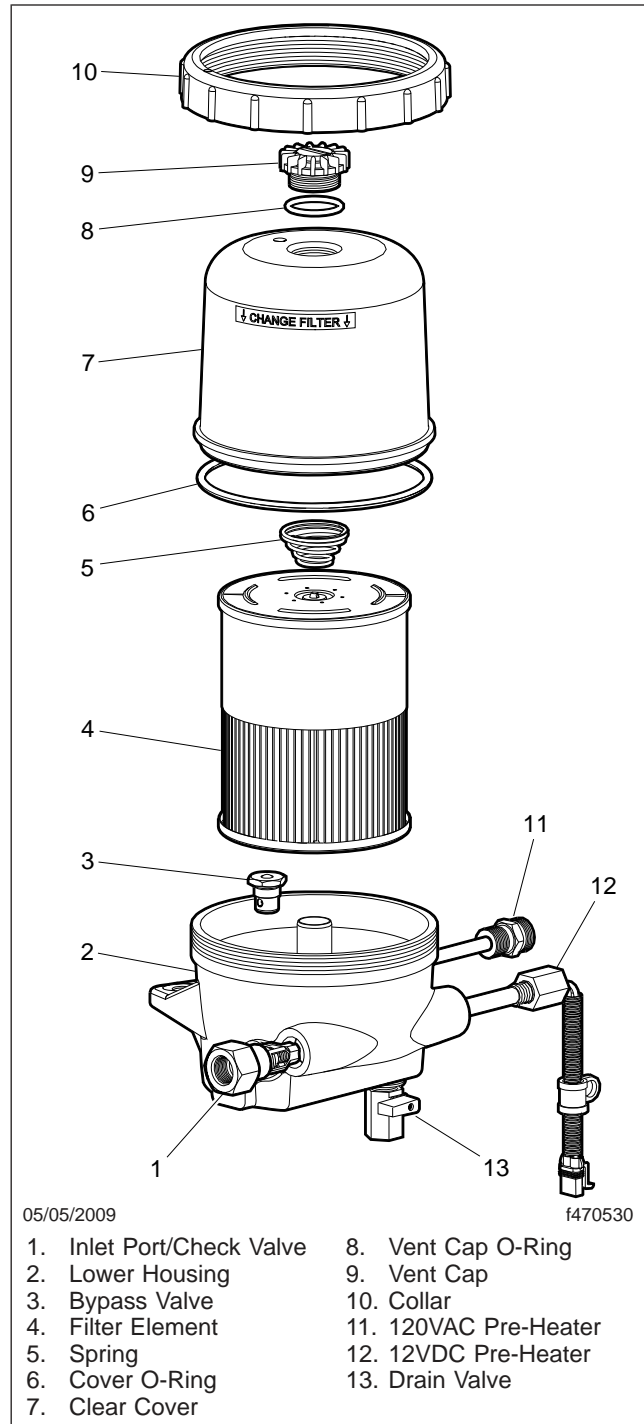

Fig. 21.13, DAVCO Fuel/Water Separator (Fuel Pro 482 shown)

Pre- and Post-Trip Inspections and Maintenance

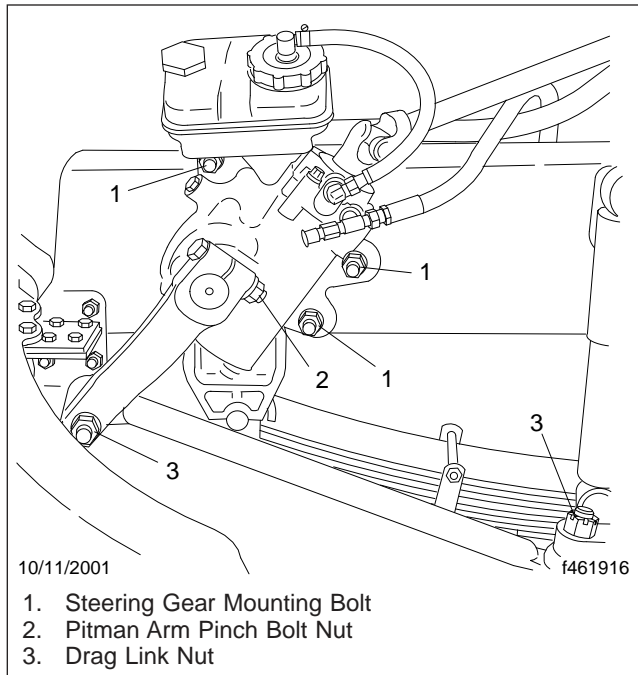

Fig. 21.14, Steering Gear Fasteners

brake chamber. Once inside of the chamber, dirt and debris can cause the internal parts of the chamber to deteriorate faster.

2. Inspect the exterior surfaces of brake chambers for damage. Make sure that breather holes are open and free of debris.

NOTE: Do not route air brake lines on top of anything likely to be stepped on.

3. Inspect air brake lines for dents, swelling, kinks, twisting, abrasion, and damage, especially near moving parts.
4. Inspect flex air lines for deterioration or signs of abrasion.
5. Inspect for cracked, worn, or oil-contaminated brake linings and brake drums (or rotors).
6. Check the thickness of the brake linings. Replace brake linings on all brake assemblies on the axle if any brake linings are worn to less than approximately 1/4 inch (6.4 mm) at the thinnest point.

Saddle Tank Areas Inspection

WARNING

When draining the air reservoir, do not look into the air jets or direct them toward anyone. Dirt or sludge particles may be in the airstream and could cause injury.

NOTICE

If the water drained from the air reservoirs is cloudy or oily, it may indicate a problem with the compressor. If oil is allowed to contaminate the air dryer, it will not remove the water from the air brake system, which could adversely affect braking.

1. Drain the brake system air reservoirs (reservoirs with automatic drain valves only).
2. Inspect the batteries.

WARNING

Battery posts, terminals, and related accessories contain lead and lead compounds, chemicals known to the State of California to cause cancer and reproductive harm. To prevent possible personal injury, always wash your hands after handling battery parts and related accessories.

- 2.1 Remove the battery box cover and inspect all visible battery cables for loose wiring or damage. See Fig. 21.15.
- 2.2 Check that the battery hold-down is secure.

IMPORTANT: Aerodynamic components decrease drag force as a vehicle moves, thereby improving fuel efficiency. If replacement of an aerodynamic component is necessary, replacement components must meet or exceed the drag reduction performance of the originally installed component in order to maintain compliance with greenhouse gas and full efficiency regulations (GHG14).

3. Inspect the following aerodynamic components, if equipped, for structural damage, cracks, or wear.
 - Chassis fairings

Pre- and Post-Trip Inspections and Maintenance

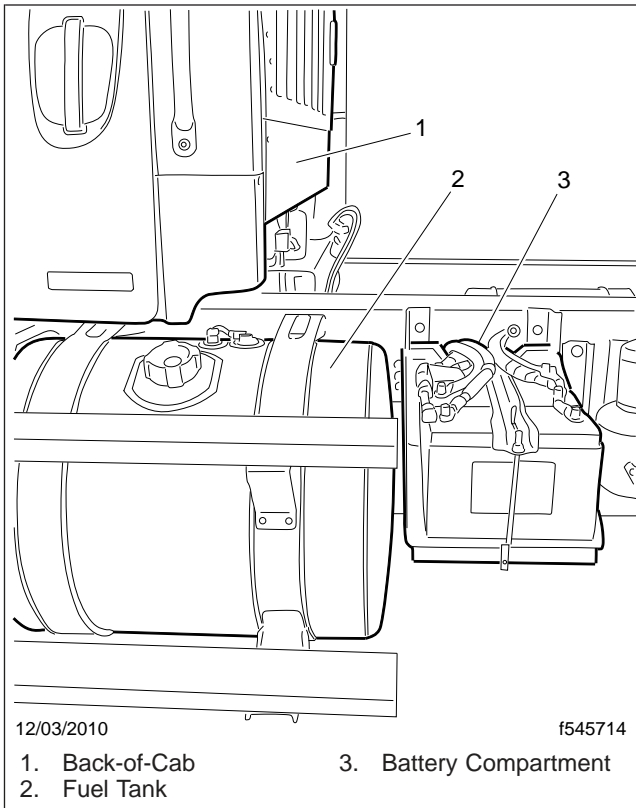

Fig. 21.15, Standard Battery Compartment Location

- Roof fairing/deflector
- Side skirts
- Cab extenders
- Battery access cover

Engine Compartment Inspection and Adjustments

IMPORTANT: If replacement of the hood or bumper is necessary, the replacement component must meet or exceed the drag reduction performance of the originally installed item in order to maintain compliance with greenhouse gas and full efficiency regulations (GHG14).

1. Inspect the bumper and hood for structural damage, cracks, or wear.
2. Inspect the radiator and heater hoses, including the clamps and support brackets.

- 2.1 Make sure the radiator inlet and outlet hoses are pliable and are not cracking or ballooning.
- 2.2 Make sure the heater hoses are pliable and are not cracking or ballooning.
- 2.3 Tighten hose clamps as necessary.
IMPORTANT: Do not overtighten hose clamps, as hose life can be adversely affected.
- 2.4 Ensure hose support brackets are securely fastened. Make sure hoses are not located near sources of wear, abrasion, or high heat.

IMPORTANT: When replacing hoses, install service-type knitted or braided yarn-reinforced neoprene hose. Extended-service-life silicone hoses may also be used. See the Alliance Parts Catalog at www.alliancebrandparts.com or contact your Freightliner Dealer.

3. Check the steering wheel for excessive play.
 - 3.1 Start the engine. With the front tires straight ahead, turn the steering wheel until motion is observed at the front wheels.
 - 3.2 Align a reference mark on the steering wheel to a rule, then slowly turn the steering wheel in the opposite direction until motion is again detected at the wheels.
 - 3.3 Measure the lash (free play) at the rim of the steering wheel. Excessive lash exists if steering wheel movement exceeds 2-1/2 inches (64 mm) with a 20-inch (508-mm) steering wheel, or 2-1/4 inches (57 mm) with an 18-inch (450-mm) steering wheel.
 - 3.4 If there is excessive lash, check the steering system for wear or incorrect adjustment before operating the vehicle.

Natural Gas Fuel System Inspection, If Equipped

1. Leak test all fuel system components, joints, and fittings using a methane detector. A bubble solution can be used to pinpoint the exact location of leaks.

Pre- and Post-Trip Inspections and Maintenance

Replace any leaking or damaged fuel tanks and fuel lines; repair or replace leaking or damaged fittings.

2. Drain the CNG high-pressure fuel filter housing, if equipped.
 - 2.1 Purge the CNG fuel lines by closing the CNG fuel cylinder shutoff valves. Start the engine and let it idle until the fuel lines are empty and the engine stops.

Gauges on the fuel panel should now read at or near 0 psi (0 kPa).
 - 2.2 Close the manual fuel shutoff valve on the fuel panel.
 - 2.3 Remove the two capscrews that secure the access cover to the fuel panel, then remove the access cover. See [Fig. 21.16](#). Save the capscrews for installation.
 - 2.4 Slowly open the bleed valve on the manifold to relieve remaining fuel pressure within the system. See [Fig. 21.17](#).

IMPORTANT: Some pressure may remain in the fuel system between the solenoid valve and the engine. Use caution when loosening fittings, as a small amount of gas may leak out.

- 2.5 Put a clean receptacle under the filter assembly.
- 2.6 Using an 11/16-inch wrench, remove the drain plug from the filter bowl.

When all liquid has drained, install and tighten the drain plug on the filter bowl.
- 2.7 Close the bleed valve on the manifold and open the manual fuel shutoff valve on the fuel panel.

Open the fuel cylinder shutoff valves.
- 2.8 Use a methane detector to leak test all fuel system components between the fuel cylinders and the solenoid valve. A bubble solution can be used to pinpoint the exact location of leaks.

Repair or replace any leaking components.
- 2.9 Install the access cover on the fuel panel.

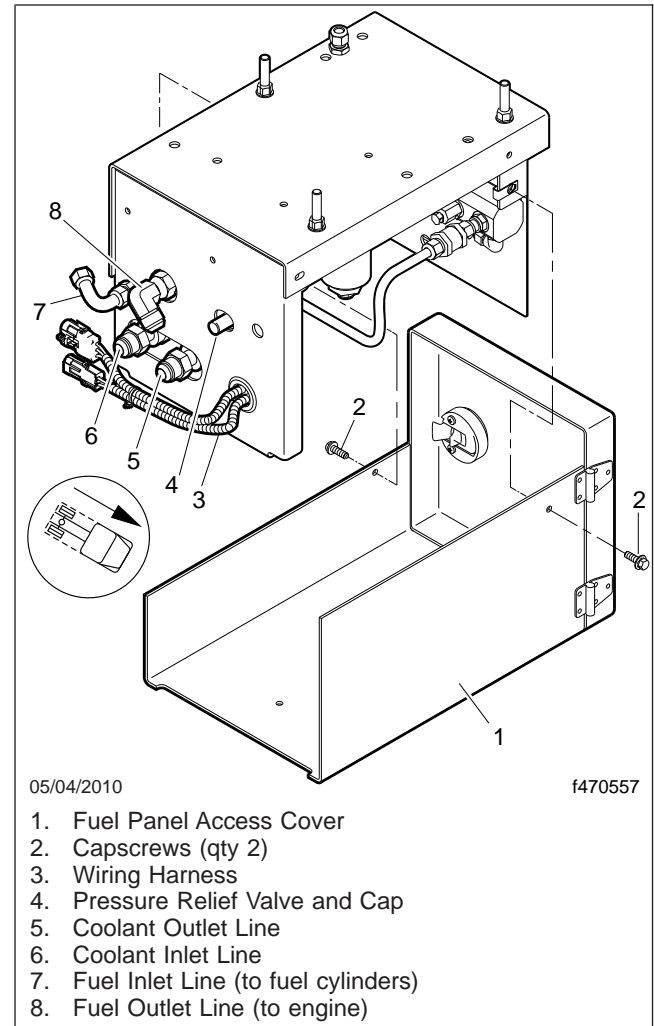

Fig. 21.16, CNG Fuel Panel Assembly

Pre- and Post-Trip Inspections and Maintenance

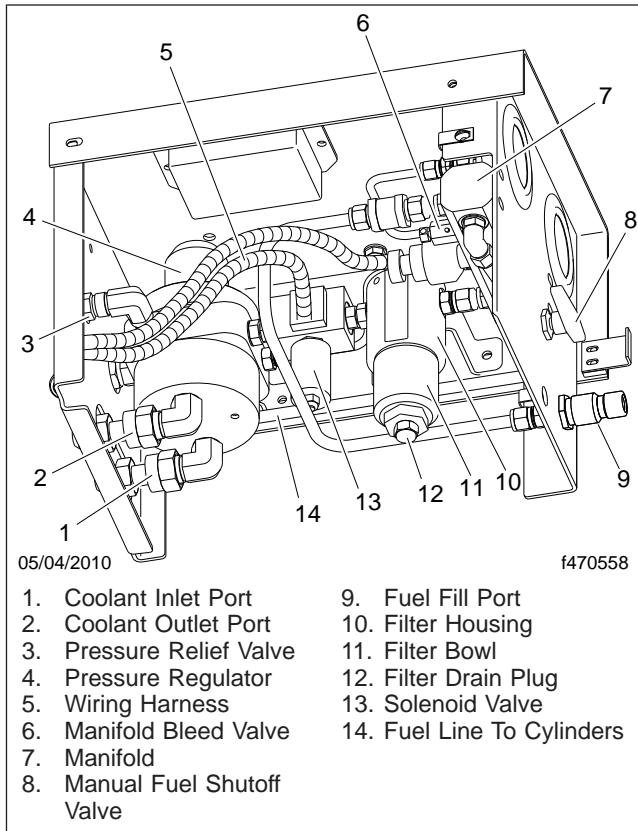

Fig. 21.17, CNG Fuel Panel Components

22

Cab Appearance

Cab Washing and Polishing	22.1
Care of Fiberglass Parts	22.1
Care of Chrome Parts	22.1
Care of Exterior Lights	22.1
Dashboard and Instrument Panel Care	22.1
Vinyl Upholstery Cleaning	22.2
Velour Upholstery Cleaning	22.3

Cab Appearance

Cab Washing and Polishing

IMPORTANT: Carefully read all instructions before using or applying any cleaner or product on the vehicle or components. Failure to follow manufacturers' recommendations can result in damage to the finish.

To protect the finish of your new vehicle, follow these guidelines carefully.

- During the first 30 days, rinse your vehicle frequently with water. If the vehicle is dirty, use a mild liquid soap. Do not use detergent.
- During the first 30 days, do not use anything abrasive on your vehicle. Brushes, chemicals, and cleaners may scratch the finish.
- During the first 120 days, do not wax your vehicle.

To extend the life of your vehicle's finish, follow these guidelines.

- Avoid washing your vehicle in the hot sun.
- Always use water. After the cab is completely washed, dry it with a towel or chamois.
- Do not dust painted surfaces with a dry cloth, as this will scratch the paint.
- Do not remove ice or snow from a painted surface with a scraper of any sort.
- To prevent damage to the finish, wax it regularly. Before waxing, if the finish has become dull, remove oxidized paint using a cleaner specifically designed for this purpose. Remove all road tar and tree sap before waxing. Freightliner recommends using a high quality brand of cleaner or cleaner-polish and polishing wax.
- Do not let diesel fuel or antifreeze stand on a painted surface. If either should occur, rinse the surface off with water.
- To prevent rust, have any nicks or other damage on the finish touched up as soon as possible.
- Park your vehicle in a sheltered area whenever possible.

Care of Fiberglass Parts

Wash unpainted fiberglass air fairings and shields monthly with a mild detergent, such as dishwashing liquid. Avoid strong alkaline cleansers.

Apply a wax specifically designed for fiberglass.

Care of Chrome Parts

To prevent rust, keep chrome parts clean and protected at all times. This is especially important during winter driving and in coastal areas where there is exposure to salt air.

When cleaning chrome parts, use clean water and a soft cloth or sponge. A mild detergent may also be used.

Sponge gently, then rinse. If necessary, use a non-abrasive chrome cleaner to remove stubborn rust or other material. Do not use steel wool.

To help protect the chrome after cleaning, apply a coat of polishing wax to the surface. Never use wax on parts that are exposed to high heat, such as exhaust pipes.

Care of Exterior Lights

Clean the headlight lenses by hand only. Use a flannel cloth with mild, non-caustic soap or detergent, and water.

NOTICE

Do not use a power buffer, paper towels, chemical solvents, or abrasive cleaners on the headlight lens, all of which can remove the UV coating from the surface, and result in yellowing of the lens.

Dashboard and Instrument Panel Care

NOTICE

When cleaning the dashboard, instrument panel, or gauge lens covers, do not use Armor-All Protectant®, STP Son-of-a-Gun®, window cleaner, or other equivalent treatments. These cleaners contain vinyl plasticizers which can cause stress

crazing in the interior plastic panels and can result in cracking of the panels. Some cleaners can also have an adverse effect on the clear plastic of instrument panels and gauge lens covers, resulting in a foggy or cloudy appearance. This type of damage is not covered by vehicle warranty.

To clean the dashboard, instrument panel, and gauge lens covers, use a cloth dampened with warm soapy water. Make certain to wring the cloth out well before cleaning, as excess water will damage the electrical components.

Vinyl Upholstery Cleaning

To prevent soiling, frequent vacuuming or light brushing to remove dust and dirt is recommended. Harsh cleaning agents can cause permanent damage to vinyl upholstery.

To preserve the upholstery and prevent damage, carefully review the following sections for recommended cleaning procedures. Waxing or refinishing improves soil resistance and cleanability for all vinyls. Use any hard wax, such as that used on automobiles.

Ordinary Dirt

Wash the upholstery with warm water and mild soap, such as saddle or oil soap. Apply soapy water to a large area and allow to soak for a few minutes, then rub briskly with a cloth to remove the dirt. Repeat several times, as necessary.

If dirt is deeply imbedded, use a soft bristle brush after applying the soap.

If dirt is extremely difficult to remove, use a wall-washing preparation such as those normally found around the home. Powdered cleaners, such as those used for sinks and tiles, are abrasive and must be used with caution as they can scratch the vinyl or give it a permanent dull appearance.

Chewing Gum

Harden the gum with an ice cube wrapped in a plastic bag, then scrape it off with a dull knife. Remove any remaining traces of gum with an all-purpose light oil (peanut butter will also work). Wipe off the gum and oil substance.

Tars, Asphalts, and Creosote

Each of these items stains vinyl after prolonged contact. Wipe any of these items off immediately and carefully clean the area using a cloth dampened with naphtha.

Paint, Shoe Heel Marks

Remove paint immediately. Do not use paint remover or liquid-type brush cleaner on vinyl. An unprinted cloth, dampened with naphtha or turpentine may be used. Use care to prevent contact with parts of the upholstery that are not vinyl.

Sulfide Stains

Sulfide compounds, such as those found in eggs and some canned goods, can stain after prolonged contact with vinyl. Remove these stains by placing a clean, unprinted piece of cloth over the spotted area and pouring a liberal amount of 6 percent hydrogen peroxide onto the cloth. Allow the saturated cloth to remain on the spot for 30 to 60 minutes. For stubborn spots, allow the hydrogen-peroxide saturated cloth to remain on the area overnight. Use caution to prevent the solution from seeping into the seams, where it can weaken the cotton thread.

Nail Polish and Nail Polish Remover

Prolonged contact with these substances causes permanent damage to vinyl. Careful blotting immediately after contact minimizes damage. Do not spread the liquid during removal.

Shoe Polish

Most shoe polishes contain dyes which penetrate vinyl and stain it permanently. Wipe shoe polish off as quickly as possible using naphtha or lighter fluid. If staining occurs, try the procedure used for sulfide stains.

Ball Point Ink

Rub ball point ink immediately with a damp cloth, using water or rubbing alcohol. If this does not work, try the procedure used for sulfide stains.

Miscellaneous

If stains do not respond to any of the treatments described above, it is sometimes helpful to expose the

Cab Appearance

vinyl to direct sunlight for up to 30 hours. Mustard, ball point ink, certain shoe polishes, and dyes often bleach out in direct sunlight, leaving the vinyl undamaged.

Velour Upholstery Cleaning

To prevent soiling, frequent vacuuming or light brushing to remove dust and dirt is recommended. Spot clean with a mild solvent or an upholstery shampoo, or the foam from a mild detergent. When using a solvent or a dry-cleaning product, follow the instructions carefully, and clean only in a well-ventilated area. Avoid any product that contains carbon tetrachloride or other toxic materials. With either method, pretest a small area before proceeding. Use a professional upholstery cleaning service when extensive cleaning is needed.

Grease and Oil-Based Stains

Dampen a small absorbent cloth with dry-cleaning solvent or spot remover. Apply the cloth carefully to the spot from the outer edge to the center. Pat and blot the spot with a clean, dry cloth. Repeat several times, as necessary, turning the cloths so that the stain does not redeposit on the fabric.

Sugar and Water-Based Stains

Apply water-based detergent or cleaner, working in circular motions. Pat and blot as dry as possible. Repeat, if necessary, before drying thoroughly.

Chewing Gum or Wax

Harden the gum or wax with an ice cube wrapped in a plastic bag, then scrape it off with a dull knife. Absorb excess wax by placing a thick white blotter over the wax and heating with a warm (not hot) iron. Remove the remainder by using the procedure for grease and oil-based stains.

Mildew

Brush the dry fabric with a soft brush. Sponge with detergent, and blot. If the fabric is colorfast, dilute a teaspoon of bleach in one quart (one liter) of cool water. Apply with a swab, directly on the mildew stain. Dab repeatedly with clear, cool water, and blot dry.

23

Headlight Aiming

Preliminary Checks	23.1
Checking Headlight Aim	23.1
Adjusting Headlight Aim	23.2

Headlight Aiming

Preliminary Checks

Before checking or adjusting the headlight aim, complete the following inspection:

- Check that the hood is closed and latched.
- Remove any large amounts of mud or ice from the underside of the fenders.
- Check the springs for sagging or broken leaves.
- Check the suspension for proper functioning of the leveling mechanism. On cabs with air suspensions, make sure that the height is properly adjusted.
- Check for damage to the hood and hinge assembly. Repair as necessary.
- With the vehicle unloaded, check that the tires are inflated to the recommended air pressure.
- Clean the headlight lenses. Use a soft cloth with mild, non-caustic soap or detergent, and water.

Checking Headlight Aim

1. Park the vehicle on a level surface, 25 ft (7.6 m) away from, and perpendicular to, a vertical screen or wall. Shut down the engine and set the parking brake. Chock the tires.
2. On each headlight, find the bulb center behind the headlight lens.
3. Measure the distance from the ground to the center of each headlight bulb (Fig. 23.1, Item A). Note those distances.
4. On the screen or wall, mark the locations of each headlight bulb center using the distances found in step 3. See Fig. 23.1, Items 2 and 3.
5. Turn on the low-beam headlights.
6. Check the vertical adjustment of the low beams. The center of each beam projection should fall on or near the marks made during step 4. See Fig. 23.2.

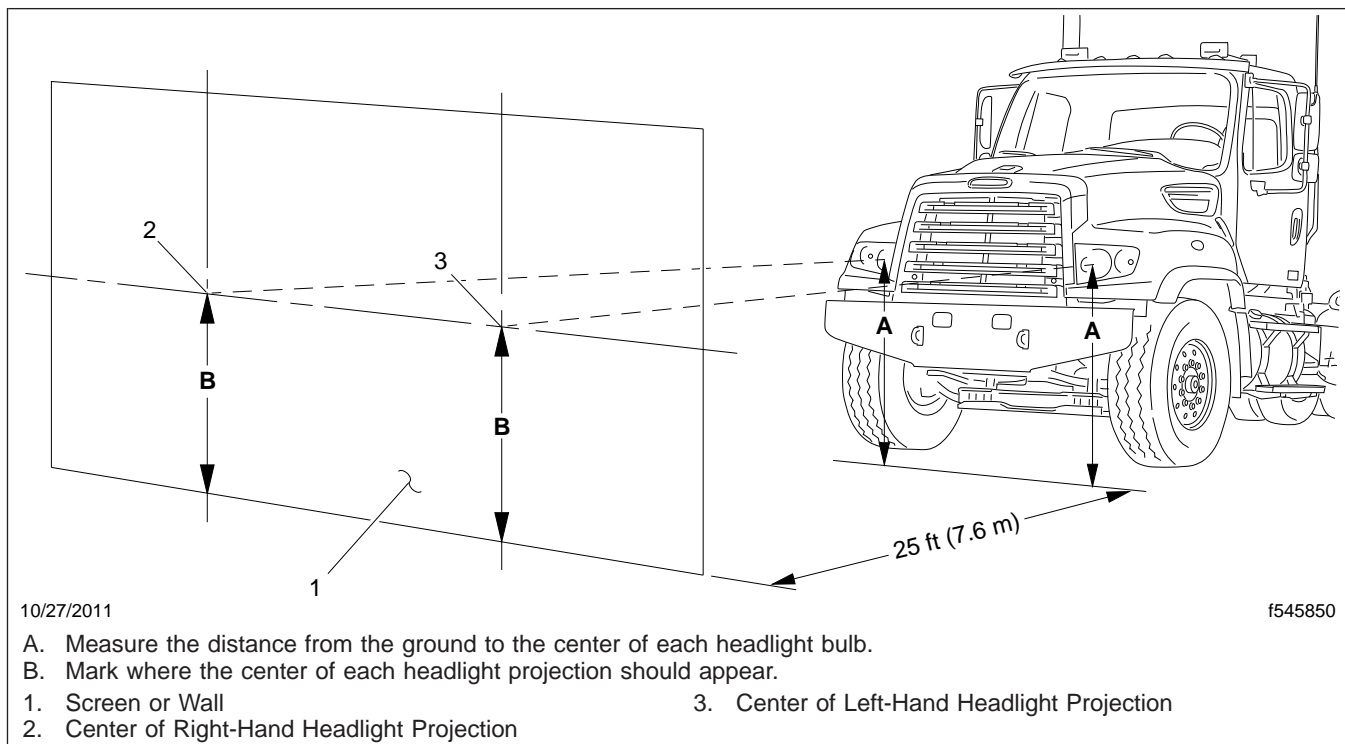

Fig. 23.1, Headlight Aiming Screen/Wall

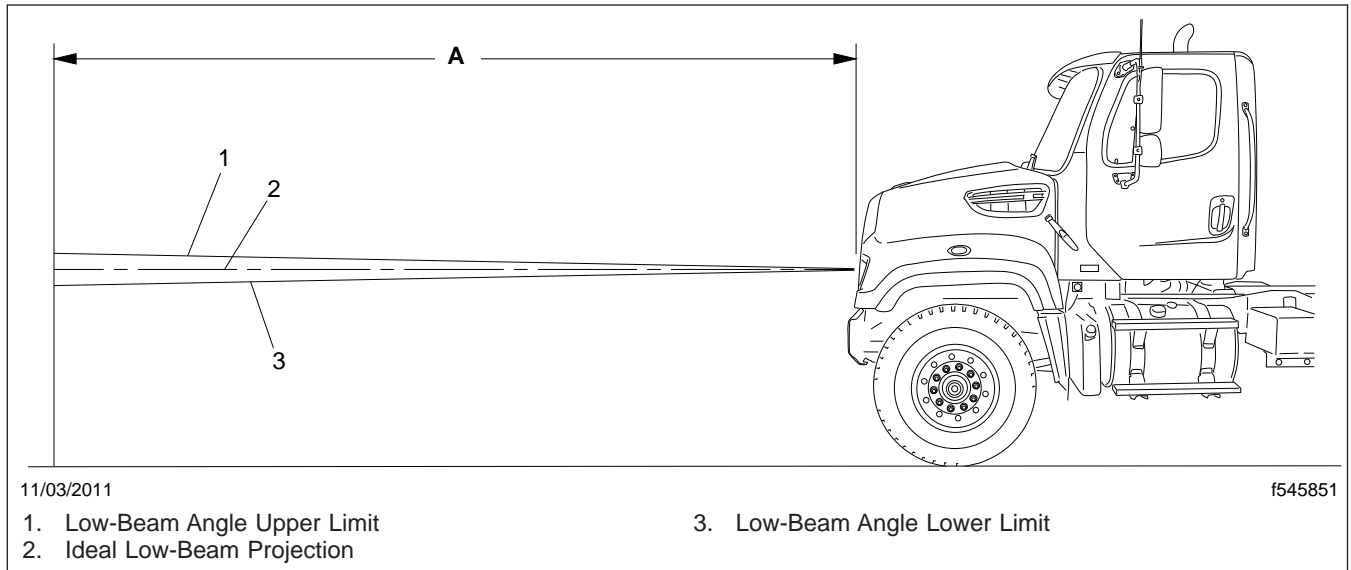

Fig. 23.2, Vertical Low-Beam Headlight Variation Limits

7. Use [Table 23.1](#) to determine the maximum vertical distance allowable between the marks on the wall and the center of each low-beam projection.
- If the distance between either projection center and the mark made on the wall or screen is greater than the maximum distance given in [Table 23.1](#), adjust the vertical positioning of that headlight.

the various options, the location of adjustment screws on your vehicle's headlight assembly may vary from what is shown here.

The adjusting screw is located on the upper inboard corner of the headlight assembly. See [Fig. 23.3](#). Turn the adjusting screw clockwise to raise the beam and counterclockwise to lower it, until the beam pattern meets the acceptable standard.

Adjusting Headlight Aim

NOTE: Freightliner vehicles are offered with various headlight assembly options. Because of

Vertical Low-Beam Headlight Variation Limits			
Distance Between Ground and Headlight: in (mm)	Desired Variation (Fig. 23.2, Item 2): in (mm)	Upper Limit (Fig. 23.2, Item 1): in (mm) up	Lower Limit (Fig. 23.2, Item 3): in (mm) down
22–36 (560–900)	0	3.9 (100)	3.9 (100)
36–48 (900–1200)	2 (50) down	2 (50)	6 (150)
48–54 (1200–1400)	2.5 (64) down	1.6 (40)	6.5 (165)

Table 23.1, Vertical Low-Beam Headlight Variation Limits

Headlight Aiming

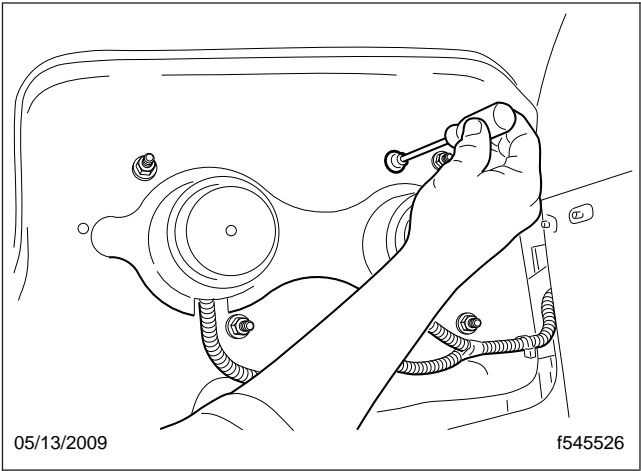

Fig. 23.3, Headlight Adjusting

24

In an Emergency

Hazard Warning Lights	24.1
Fire Extinguisher	24.1
Emergency Kit	24.1
Emergency Filter Replacement, DAVCO	24.1
Emergency Starting With Jumper Cables	24.2
Towing	24.5
Fire in the Cab	24.6

In an Emergency

Hazard Warning Lights

The hazard warning light flasher (**Fig. 24.1**) is part of the multifunction turn signal switch. It is a red rocker switch located on the top of the multifunction switch module.

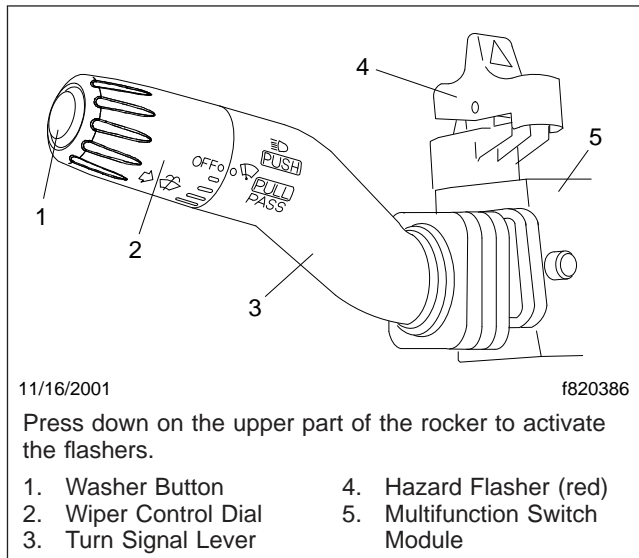

Fig. 24.1, Hazard Warning Flashers

To activate the hazard warning lights, press down on the upper part of the rocker (pushing towards the dash). To deactivate the hazard warning lights, press down on the lower part of the rocker (towards the steering wheel).

Fire Extinguisher

A fire extinguisher is located in the cab by the driver's door.

Emergency Kit

An optional emergency kit is located in the cab. The kit includes one or more of the following: a first aid kit, a reflective vest, a triangular reflector, a flare kit, and (on vehicles with a DAVCO fuel/water separator) a spin-on fuel filter element.



WARNING

Use extreme care when placing flares in emergency situations that involve exposure to flam-

able substances such as fuel. An explosion or fire could occur causing serious personal injury.

If there is an emergency while driving, cautiously pull off the road. Turn on the hazard warning lights. Place the flares and reflector along the side of the road to alert other drivers that an emergency situation exists.

Emergency Filter Replacement, DAVCO

If the filter cover on the DAVCO fuel/water separator is broken, it will not be possible to operate the vehicle. A standard spin-on filter will correct this problem.

Refer to the DAVCO web site for additional information, www.davcotec.com.



WARNING

Fluid circulated through the fuel/water separator to heat the fuel may be diesel fuel returned from the engine, or engine coolant. Drain the fuel/water separator only when the engine and fluids have cooled. Draining it when the engine is hot could cause severe personal injury due to scalding.

If returning fuel is released into the atmosphere, its vapors can ignite in the presence of any ignition source. Do not expose the fuel to, or work with the fuel system near, open flame or intense heat. To do so could cause fire, possibly resulting in serious personal injury or property damage.

1. Shut down the engine, apply the parking brake, and chock the tires.
2. Put a clean receptacle under the fuel/water separator and attach a piece of hose to the drain valve, to direct fuel into the receptacle.

NOTE: The drain valve on the Fuel Pro 382 has a 1/2-inch (12.7-mm) opening; use a hose with a 1/2-inch pipe thread to fit correctly.

3. Remove the vent cap (**Fig. 24.2**, Item 4) and open the drain valve (**Fig. 24.2**, Item 1) to drain the fuel to just below the collar level, then close the drain valve.
4. Using a DAVCO collar wrench (**Fig. 24.3**), remove the clear cover and collar.

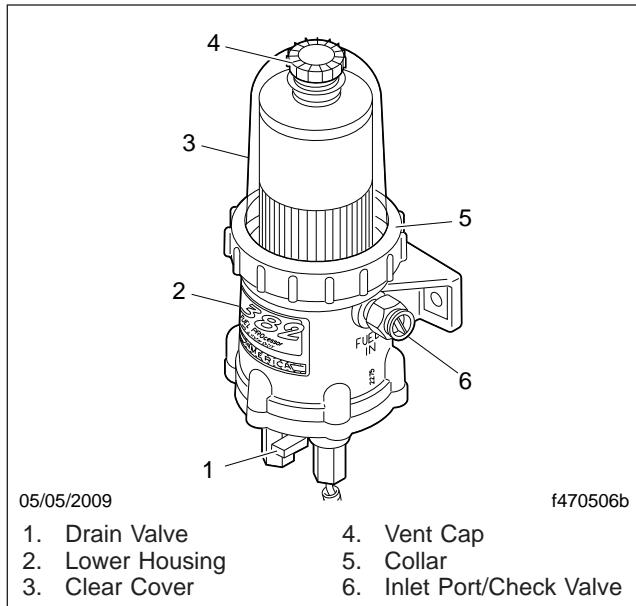

Fig. 24.2, DAVCO Fuel/Water Separator (Fuel Pro 382 shown)

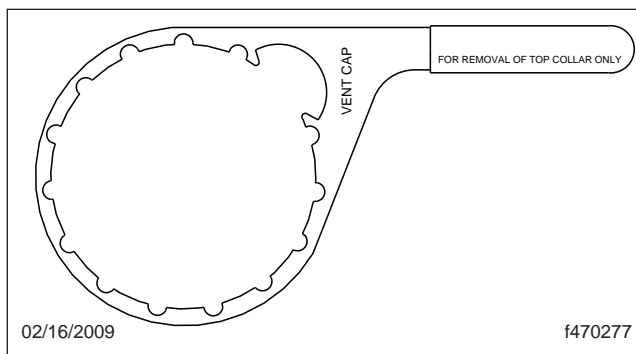

Fig. 24.3, DAVCO Collar Wrench

NOTE: Broken vent cap and collar warranty claims will not be accepted if any tool other than a DAVCO collar wrench, p/n 380134 or 382002, is used for removal. During installation, the vent cap and collar are to be **hand-tightened only**, not tightened with a wrench.

5. Remove the filter and dispose of it in an environmentally acceptable manner.
6. Clean all threads and sealing surfaces very thoroughly. Even a small amount of dirt will prevent the fuel/water separator from sealing, and an air leak will result.

7. Ensure that the drain valve is closed.
8. Remove the filter grommet from the filter stud, if equipped.
9. Fill the housing to the top with clean diesel fuel.
10. Install a standard fuel filter element on the filter stud. If a standard filter element is not available, install a spin-on fuel filter element (part number FF105 or equivalent).
11. Install the cover O-ring, clear cover, and the collar. Hand-tighten the collar.
12. Install and hand-tighten the vent cap O-ring and vent cap.
13. Start the engine. When the lubricating oil reaches its normal operating pressure, increase engine speed to high idle for one to two minutes to purge air from the system.

Emergency Starting With Jumper Cables

When using jumper cables, follow the instructions below.

WARNING

Batteries release explosive gas. Do not smoke when working around batteries. Put out all flames and remove all sources of sparks or intense heat in the vicinity of the battery. Do not allow the vehicles to touch each other. Do not lean over the batteries when making connections, and keep all other persons away from the batteries. Failure to follow these precautions could lead to severe personal injury as a result of an explosion or acid burns.

NOTICE

Make sure both electrical systems are the same voltage. Electronic devices on both vehicles can be damaged when connected to a vehicle with a different operating voltage.

1. Apply the parking brakes and turn off all lights and other electrical devices. Ensure that the vehicles are not touching and both ignition switches are turned to the OFF position.

In an Emergency

IMPORTANT: Do not attempt to jump start a damaged battery.

2. Remove the battery box cover. See [Fig. 24.4](#) for the standard battery compartment location.

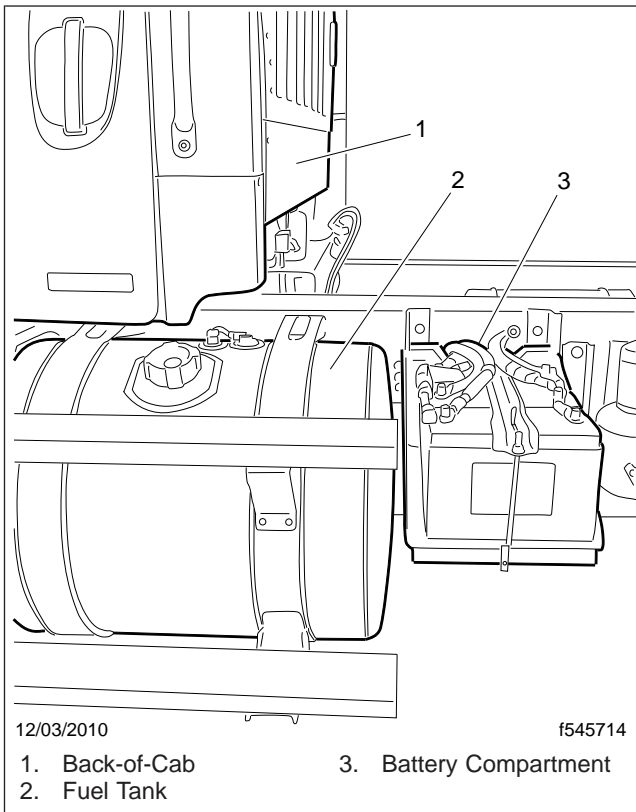

Fig. 24.4, Standard Battery Compartment Location

NOTICE

Always connect the batteries and jumper cables correctly (positive-to-positive and negative-to-negative). Connecting a charging device backwards (positive-to-negative) can severely damage the vehicle electrical content and cause non-warrantable failures.

IMPORTANT: On vehicles equipped with optional jump start posts, connect to these posts instead of the battery terminals. Jump start posts may be installed in various locations on the vehicle. See [Fig. 24.5](#).

3. Connect the positive (+) jumper cable to the positive terminal or jump start post on the discharged battery. See [Fig. 24.6](#).

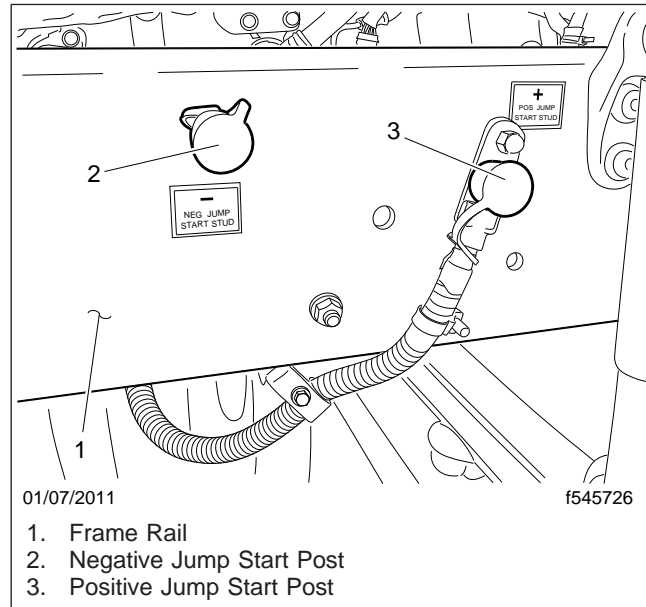

Fig. 24.5, Possible Jump Start Post Location (passenger-side engine compartment)

4. Connect the other end of the positive jumper cable to the positive terminal or jump start post on the booster battery providing the charge.

⚠ WARNING

Do the next step exactly as instructed and do not allow the clamps of one cable to touch the clamps of the other cable. Otherwise, a spark could occur near a battery, possibly resulting in severe personal injury from explosion or acid burns.

5. Connect the negative (-) jumper cable to the negative terminal or jump start post on the booster battery.
6. Connect the other end of the negative jumper cable to the negative ground stud on the vehicle requiring the jump start.
7. Start the engine of the vehicle providing the jump start and let the engine run a few minutes to charge the batteries of the other vehicle.

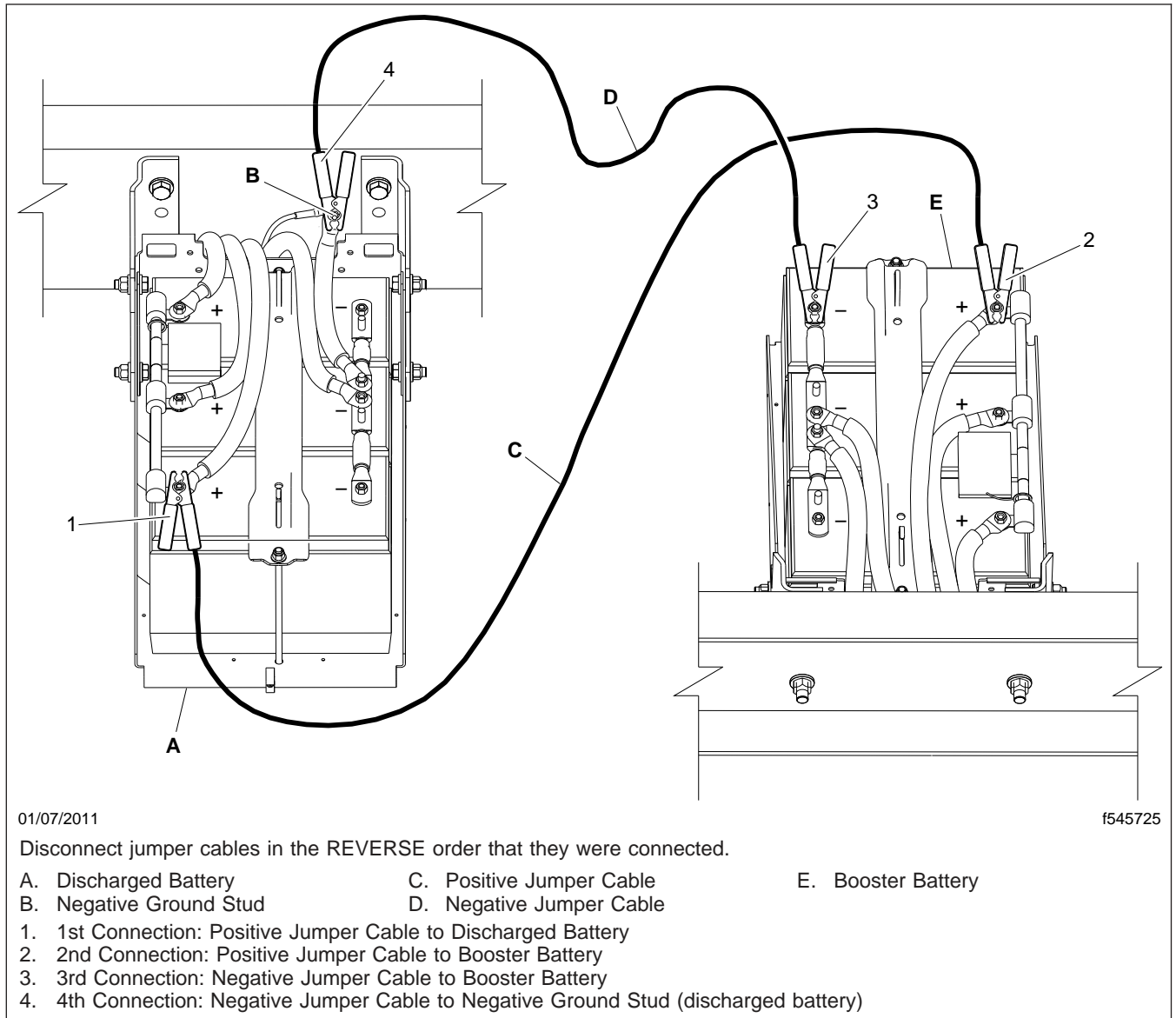

Fig. 24.6, Jumper Connections

8. Attempt to start the engine of the vehicle receiving the jump. Do not operate the starter longer than 30 seconds, and wait at least two minutes between starting attempts to allow the starter to cool.
9. When the engine starts, let it idle a few minutes.

WARNING

Do the next step exactly as instructed and do not allow the clamps of one cable to touch the clamps of the other cable. Otherwise, a spark could occur near a battery, possibly resulting in severe personal injury from explosion or acid burns.

In an Emergency

10. Disconnect the negative jumper cable from the negative cable stud on the jump started vehicle.
11. Disconnect the negative jumper cable from the booster battery.
12. Disconnect the positive cable from the booster battery.
13. Disconnect the other end of the positive jumper cable from the jump started vehicle.
14. Install the battery box cover; be sure it is positioned properly before fastening the latch.

Towing

When it is necessary to tow the vehicle, make sure the instructions below are closely followed to prevent damage to the vehicle.

 **WARNING**

Do not tow an unbraked vehicle if the combined weight of both vehicles is more than the sum of the gross axle weight ratings (GAWR) of the towing vehicle. Otherwise brake capacity will be inadequate, which could result in personal injury or death.

Front Towing Hookup

1. Disconnect the batteries at the negative terminals.

NOTICE

Failure to remove the axle shafts or the driveline when towing the vehicle with the rear wheels on the ground could result in damage to the transmission and other parts.

2. Remove the driveline from any drive axle that will have its wheels touching the ground while the vehicle is towed,

or

remove the drive axle shafts on both sides of the vehicle from any drive axle that will have its wheels touching the ground while the vehicle is towed.

3. If the axle shafts were removed, cover the ends of the hubs with metal plates or plywood cut to fit the axle opening, and drilled to fit the axle shaft

studs. This prevents lubricant from leaking out and will keep contaminants from getting into and damaging the wheel bearings and axle lubricant.

If the driveline(s) were removed, ensure the U-joint caps are secure so they will not come off.

NOTICE

Failure to protect the frame rails from the chains could cause damage, leading to eventual frame failure.

4. If a vehicle with tandem rear axles is to be lifted and towed, chain the forward rear-axle assembly to the vehicle frame. This will prevent the forward rear-axle assembly from dropping and keep its wheels off the ground while being towed.

Use protection to keep the chains from damaging the frame.

5. Remove the bumper end caps and chrome bumper, if equipped.

NOTICE

Do not pass a sling (for example, a rope or chain) from one tow hook to another to fasten for towing. Known as reeving, this practice is *not* permissible in most industrial applications of towing and hoisting. Reeving can overload the hooks and result in damage to the vehicle.

6. Attach the towing device. Due to the many variables that exist in towing, positioning the lifting and towing device is the sole responsibility of the towing-vehicle operator.
7. Lift the vehicle and secure the safety chains. If extra towing clearance is needed, remove the front wheels.
8. Connect the clearance lights, taillights, and signal lights. Connect any special towing lights required by local regulations.

 **WARNING**

Failure to chock the tires or connect the tow truck's air brake system before releasing the spring parking brakes could allow the disabled vehicle to suddenly roll. This could cause property damage or personal injury.

9. Chock the tires on the disabled vehicle and connect the towing vehicle's air brake system to the vehicle being towed. Then, release the spring parking brakes and remove the chocks.

Rear Towing Hookup

NOTICE

Using a rear towing hookup on a vehicle equipped with a roof fairing could cause damage to the cab structure.

If reverse towing at speeds above 45 mph (70 kph) is necessary, hold down the cab with tension straps looped over the cab shocks and under the frame rails. Failure to do so could allow the wind load to lift the cab unexpectedly, resulting in damage to the air springs and other components.

1. If the vehicle is equipped with cab air suspension, and reverse towing at speeds above 45 mph (70 kph) is necessary, hold down the cab as follows:
 - 1.1 Drain the air from the cab air springs.
 - 1.2 Loop a 2-inch (5-cm) ratchet-style tension strap (rated 2000 lb [900 kg] minimum work load) over the top of the cab shock and under the frame rail. Tighten the strap for a snug fit. See Fig. 24.7. If the cab is equipped with two or more shocks, restrain the aftmost shock on each side of the vehicle.
2. Place the front tires straight forward and secure the steering wheel in this position.
3. Disconnect the battery ground cables.

NOTICE

Failure to protect the frame rails from the chains could cause damage, leading to eventual frame failure.

4. On dual drive axles, using protection to keep the chains from damaging the vehicle frame, chain the forward-rear drive axle to the frame.
5. Attach the towing device.



Fig. 24.7, Tension Strap Installed to Hold Down the Cab

NOTE: Due to the many variables that exist in towing, positioning the lifting and towing device is the sole responsibility of the towing-vehicle operator.

6. Lift the vehicle and secure the safety chains. If extra clearance is needed, remove the bumper extension if equipped.
7. Connect the clearance lights, taillights, and signal lights. Also connect any special towing lights required by local regulations.

Fire in the Cab

The incidence of fire in trucks is rare, according to data from the National Highway Traffic Safety Administration. Federal Motor Vehicle Safety Standard #302 limits the flammability of specified materials used inside the cab, but despite this, most materials will burn. The cab of this vehicle contains urethane foam, which is of concern in this respect.

In an Emergency

 WARNING
--

Urethane foam is flammable! Do not allow any flames, sparks, or other heat sources such as cigarettes or light bulbs to contact urethane foam. Urethane foam in contact with such heat sources could cause a serious, rapid fire, which could result in death, severe burns, or gas poisoning, as well as damage to the vehicle.

In Case of a Cab Fire

As quickly as possible, bring the vehicle to a safe stop, apply the parking brake, turn off the ignition, and get out of the vehicle.

Index

Subject	Page
A	
Adjustable Steering Column Controls	5.13
Adjusting Headlight Aim	23.2
Air Brake System	12.1
Automatic Slack Adjusters	12.3
Brake System Conditions	12.1
Brake System General Information	12.1
Brake System Operation	12.1
Air-Suspension Dump Valve	18.1
All Wheel Drive Controls	5.11
AWD Operation Switch	5.11
AWD Range Switch	5.11
Allison Automatic Transmissions	14.13
General Information, Allison Transmissions	14.13
Operation Tips, Allison Transmissions	14.13
Auxiliary Braking Applications	10.3
Engine Brake	10.3
Exhaust Brake, Cummins Engines	10.5
B	
Back-of-Cab Access	2.4
Climbing Down from Back-of-Cab	2.4
Climbing Up to Back-of-Cab	2.4
Battery Access	3.2
Bostrom Seat	6.3
Backrest Tilt, Bostrom Seat	6.4
Bottom Cushion Tilt, Bostrom Seat	6.4
Fore-and-Aft Seat Adjustment, Bostrom Seat	6.4
Height Adjustment, Bostrom Seat	6.4
Isolator, Bostrom Seat	6.4
Lumbar Support, Bostrom Seat	6.4
Brake Controls	5.12
Antilock Braking System	5.12
Parking Brake Control Valve	5.12
Trailer Air Supply Valve	5.12
Trailer Brake Lever	5.12
C	
Cab Amenities	8.1
Cab Storage	8.1

Subject	Page
Cup Holders	8.1
Cab Entry and Exit	2.2
Entering from the Driver's Side	2.2
Entering from the Passenger's Side	2.3
Exiting from the Driver's Side	2.2
Exiting from the Passenger's Side	2.3
Cab Washing and Polishing	22.1
Canadian Motor Vehicle Safety Standard Labels	1.1
Care of Chrome Parts	22.1
Care of Exterior Lights	22.1
Care of Fiberglass Parts	22.1
Checking Headlight Aim	23.1
Checklists	20.1
Daily Pretrip Inspection Checklists	20.1
Monthly Post-trip Inspection Checklists	20.2
Weekly Post-trip Inspection Checklist	20.2
Climate Control Panel	7.1
Accessory Heaters	7.4
Air Conditioning, Optional	7.3
Air Selection Switch	7.1
Defrosting	7.3
Fan Switch	7.1
Fresh Air Mode	7.3
Recirculation Mode	7.3
Temperature Control Switch	7.3
Climate Controls	5.14
Clutch	13.5
Clutch General Information	13.5
Clutch Maintenance	13.7
Clutch Operation	13.6
Component GWR Label	1.1
Component Information Label	1.1
Control Panels	5.1
Cruise Control	10.2
D	
Daily Pretrip Inspection and Maintenance	21.1
Cab Inspection	21.5
Engine Compartment Inspection	21.4
Natural Gas Fuel System Inspection, If Equipped	21.8
Saddle Tank Areas Inspection	21.4

Subject	Page	Subject	Page
Suspension and Slack Adjuster Inspection	21.1	Auto Start Gear Selection and Override	14.9
Wheel and Tire Inspection	21.1	Automatic Mode (AUTO)	14.7
Dashboard and Instrument Panel Care	22.1	Automatic Traction Control	14.10
Diesel Exhaust Fluid and Tank	11.3	Clutch Abuse Protection	14.8
DEF Tank	11.4	Coasting	14.10
DEF Warnings and Engine Limits	11.5	Creep Mode	14.9
Diesel Exhaust Fluid	11.3	Engine Overspeed Protection	14.9
Fuel/DEF Gauge	11.4	Hill Start Aid	14.9
Differential Lock, Drive Axles	15.1	Load-Based Shifting	14.10
Differential Lock Operation	15.1	Low (L)	14.8
Differential Lock Switch	15.1	Manual Mode (MAN)	14.8
Single Drive Axles with Traction Equalizer	15.2	Power Down	14.7
Door Locks and Handles	2.1	Power Up	14.7
Driver Message Center	4.7	Reverse (R)	14.7
Driving Screens	4.7	Shuttle Shifting	14.9
Parked Screens/Menus	4.7	Skip Shifting	14.9
E			
Eaton Fuller 10-Speed Range-Shift Transmissions	13.4	Emergency Filter Replacement, DAVCO	24.1
General Information, 10-Speed Range-Shift Transmissions	13.4	Emergency Kit	24.1
Operation Tips, Eaton Fuller Range-Shift Transmissions	13.4	Emergency Starting With Jumper Cables	24.2
Eaton Fuller 13-Speed and 18-Speed Splitter and Range-Shift Transmissions	13.1	Emissions Labels	1.1
General Information, Eaton Fuller Splitter and Range-Shift Transmissions	13.1	Aftertreatment System Indicators Label	1.1
Operation Tips, Eaton Fuller Splitter and Range-Shift Transmissions	13.2	Certified Clean Idle Label	1.4
Eaton Fuller AutoShift Automated Transmissions	14.10	EPA Noise Emission Control Label	1.2
General Information, AutoShift Transmissions	14.10	Vehicle Emission Control Information Label	1.4
Operation, AutoShift Transmissions	14.10	Engine Idle Limiting	10.2
Eaton Fuller UltraShift DM Automated Transmissions	14.1	California Engine Idle Limiting	10.2
General Information, Ultrashift Transmissions	14.1	Idle Shutdown Timer	10.2
Operation, UltraShift Transmissions	14.2	Engine Operation	9.2
Ultrashift Diagnostics	14.5	Cold-Weather Operation	9.3
Eaton Fuller UltraShift PLUS Automated Transmissions	14.6	Engine Break-In	9.2
Auto Neutral	14.9	Normal Operation	9.2
		Safety and Environmental Considerations	9.2
		Engine Protection—Warning and Shutdown	10.1
		Engine Shutdown	9.3
		Engine Starting	9.1
		Cold-Weather Starting	9.1
		Starting After Extended Shutdown	9.2
		Enhanced Stability Control	12.4
		EPA-Regulated Emissions	
		Aftertreatment System	11.1
		ATS Warning Lamps	11.3
		DPF Maintenance	11.3

Index

Subject	Page
Regeneration	11.1

F

Federal Motor Vehicle Safety Standard Labels	1.1
Fifth Wheel Coupling	17.1
Fontaine and Holland Fifth Wheels Coupling	17.1
Jost Fifth Wheel Coupling	17.3
Fifth Wheel Slide	17.7
Air Slide Operation	17.9
Manual Slide Operation	17.7
Fifth Wheel Uncoupling	17.4
Air-Actuated Uncoupling	17.5
Manual Uncoupling	17.4
Fifth Wheels, General Information	17.1
Air-Suspension Dump Valve	17.1
Fifth Wheel Lubrication	17.1
Fire Extinguisher	24.1
Fire in the Cab	24.6
In Case of a Cab Fire	24.7
Fluids Added	20.2
Freightliner High-Back Seat	6.2
Backrest Tilt	6.2
Bottom Cushion Extension	6.2
Fore/Aft Isolator	6.2
Fore/Aft Seat Slide	6.2
Front Cushion Height	6.3
Heater	6.3
Height Adjustment	6.2
Lumbar Support	6.2
Rear Cushion Height	6.3
Shock Absorber	6.2
Freightliner SmartShift Shift Control	14.1
General Information, SmartShift Control	14.1

G

Greenhouse Gas Emissions and Fuel Consumption Standards	11.1
---	------

H

Hazard Warning Lights	24.1
Holland Trailer Coupling	18.1
General Information	18.1
Trailer Hookup	18.1
Trailer Release	18.1

Hood Opening and Closing	2.5
To Return the Hood	2.5
To Tilt the Hood	2.5
Horn Controls	5.6
Air Horn	5.6
Electric Horn	5.6

I

Ignition Switch	5.1
Instrumentation Control Unit	4.1
Audible Alerts	4.2
Ignition Sequence	4.1
Instruments	4.8
Air Intake Restriction Gauge	4.8
Coolant Temperature Gauge	4.9
Drive Axle Oil Temperature Gauges	4.10
Engine Oil Pressure Gauge	4.10
Engine Oil Temperature Gauge	4.10
Fuel/Diesel Exhaust Fluid (DEF) Gauge	4.11
Primary and Secondary Air Pressure Gauges	4.11
Speedometer	4.12
Tachometer	4.12
Transmission Fluid Temperature Gauge	4.12
Turbocharger Boost Pressure Gauge	4.12
Voltmeter	4.12
Interaxle Lock, Tandem and Tridem Axles	15.2
Interaxle Lock Operation	15.3
Interaxle Lock Switch	15.2

L

Lighting Controls	5.3
Exterior Light Controls	5.3
Interior Light Controls	5.5
Load Disconnect Switch	3.1

M

Major Repair and Replacement of Natural Gas Components	19.10
Meritor WABCO® Antilock Braking System	12.3
Automatic Traction Control	12.4
Trailer ABS Compatibility	12.4
Mirrors and Windows	8.1

Subject	Page	Subject	Page
Down View Mirror, Optional	8.2	In Case of Emergency	19.2
Mirror Heat Switch, Optional	8.1		
Mirrors	8.1	O	
Power Mirrors, Optional	8.1	Overhead Instrument Panel	4.13
Windows	8.2		
Monthly Post-Trip Inspection and Maintenance	21.11	P	
Brake Component Inspection	21.11	Periodic Inspections and Maintenance	20.1
Engine Compartment Inspection and Adjustments	21.13	Power Steering System	16.1
Natural Gas Fuel System Inspection, If Equipped	21.13	Steering Wheel Adjustment	16.1
Saddle Tank Areas Inspection	21.12	Power Takeoff (PTO) Governor	10.6
Multifunction Turn Signal Lever Controls	5.5	Powertrain Controls	5.7
Turn Signal Controls	5.6	Aftertreatment System Regeneration Switches	5.7
Windshield Wiper/Washer Controls	5.6	Axle Switches	5.7
N		Cruise Control Switches	5.8
National 2000 Series Seat	6.5	Engine Brake Switch	5.9
Backrest Tilt, National 2000 Series Seat	6.5	Engine Fan Switch	5.9
Bottom Cushion Fore-and-Aft Adjustment, National 2000 Series Seat	6.6	Exhaust Brake Switch	5.9
Fore-and-Aft Seat Adjustment, National 2000 Series Seat	6.6	Transmission Controls	5.10
Height Adjustment, National 2000 Series Seat	6.6	Preliminary Checks	23.1
Isolator, National 2000 Series Seat	6.6	Premier Trailer Couplings	18.2
Lumbar Support, National 2000 Series Seat	6.6	General Information	18.2
Rear Cushion Adjustment, National 2000 Series Seat	6.6	Trailer Hookup	18.2
Natural Gas Detection System	19.5	Trailer Release	18.3
Alarm Procedure	19.5	R	
Overhead Console	19.7	Roll Stability Advisor/Control	12.5
Sensors	19.6	Hard-Braking Advisor	12.6
Testing	19.7	Roll Stability Advisor	12.5
Natural Gas Fuel Tank Filling Procedures	19.2	Roll Stability Control	12.5
CNG Vehicle Fueling	19.2	Trip/Leg Totals	12.6
LNG Vehicle Fueling	19.3	S	
Natural Gas Vehicles, Engine Starting	19.9	Sears Atlas Seat	6.4
Natural Gas Vehicles, General Information	19.1	Armrest Adjustment, Sears Atlas Seat	6.5
Natural Gas Vehicles, Safety Precautions	19.1	Backrest Tilt, Sears Atlas Seat	6.5
		Fore-and-Aft Seat Adjustment, Sears Atlas Seat	6.4
		Height Adjustment, Sears Atlas Seat	6.4
		Isolator	6.4
		Lumbar Support, Sears Atlas Seat	6.5

Index

Subject	Page	Subject	Page
Seat Tilt/Extension Adjustment, Sears Atlas Seat	6.4	Weekly Post-Trip Inspection and Maintenance	21.9
Seat Belts and Tether Belts	6.6	Engine Compartment Inspection	21.9
General Information, Seat Belts and Tether Belts	6.6		
Inspection, Seat Belts and Tether Belts	6.6		
Seat Belt Operation	6.7		
Seat Controls	5.14		
Bench Seats	5.16		
Seats, General Information	6.1		
Bench Seats	6.2		
Suspension Controls	5.13		
Air Suspension Autofill Override Valve	5.13		
Air Suspension Dump Control Switch	5.13		
T			
Towing	24.5		
Front Towing Hookup	24.5		
Rear Towing Hookup	24.6		
V			
Vehicle Power Distribution	3.1		
Main Powernet Distribution Box	3.1		
Power Distribution Modules	3.1		
Velour Upholstery Cleaning	22.3		
Chewing Gum or Wax	22.3		
Grease and Oil-Based Stains	22.3		
Mildew	22.3		
Sugar and Water-Based Stains	22.3		
Vinyl Upholstery Cleaning	22.2		
Ball Point Ink	22.2		
Chewing Gum	22.2		
Miscellaneous	22.2		
Nail Polish and Nail Polish Remover	22.2		
Ordinary Dirt	22.2		
Paint, Shoe Heel Marks	22.2		
Shoe Polish	22.2		
Sulfide Stains	22.2		
Tars, Asphalts, and Creosote	22.2		
W			
Warning and Indicator Lights	4.2		
Engine Protection System	4.6		