



*Run Smart™*

# CORONADO®



---

## Driver's Manual

## Introduction

This manual provides information needed to operate and understand the vehicle and its components. More detailed information is contained in the *Owner's Warranty Information for North America* booklet, and in the vehicle's workshop and maintenance manuals.

Custom-built Freightliner vehicles are equipped with various chassis and cab components. Not all of the information contained in this manual applies to every vehicle. For details about components in your vehicle, refer to the chassis specification pages included in all new vehicles and to the vehicle specification decal, located inside the vehicle.

For your reference, keep this manual in the vehicle at all times.

**IMPORTANT:** Descriptions and specifications in this manual were in effect at the time of printing. Freightliner Trucks reserves the right to discontinue models and to change specifications or design at any time without notice and without incurring obligation. Descriptions and specifications contained in this publication provide no warranty, expressed or implied, and are subject to revisions and editions without notice.

## Environmental Concerns and Recommendations

Whenever you see instructions in this manual to discard materials, you should first attempt to reclaim and recycle them. To preserve our environment, follow appropriate environmental rules and regulations when disposing of materials.

## Event Data Recorder

This vehicle is equipped with one or more devices that record specific vehicle data. The type and amount of data recorded varies depending on how the vehicle is equipped (such as the brand of engine, if an air bag is installed, or if the vehicle features a collision avoidance system, etc.).

This vehicle is equipped with an event data recorder (EDR). The main purpose of an EDR is to record data in certain crash or near-crash situations, such as air bag deployment or hitting a road obstacle, that will assist in understanding how a vehicle's systems

performed. The EDR is designed to record data related to vehicle dynamics and safety systems for approximately 60 seconds. This data can help provide a better understanding of the circumstances in which crashes and injuries occur. Data recorded includes the following items:

- how various systems in the vehicle were operating
- engine system information
- how far (if at all) the driver was depressing the accelerator
- if the driver was depressing the brake pedal
- how fast the vehicle was traveling

**NOTE:** Data is not recorded by the EDR under normal driving conditions. Personal data such as name, gender, age, and crash location are not recorded. However, other parties such as law enforcement could combine the EDR data with the type of personally identifying data routinely acquired during a crash investigation.

To read data recorded by an EDR, special equipment is required, and access to the vehicle or the EDR is needed. In addition to the vehicle manufacturer, other parties that have the special equipment, such as law enforcement, can read the information if they have access to the vehicle or the EDR.

## Emissions and Fuel Efficiency Compliance

This vehicle must be regularly inspected and maintained as indicated in the *122SD and Coronado 132 Maintenance Manual*, and in the *Pre- and Post-Trip Inspections and Maintenance* chapter in this manual, in order to continue satisfactory performance and ensure coverage of the vehicle under the manufacturer's warranty. Many maintenance procedures ensure that the vehicle and engine continue to comply with applicable emissions standards. Maintenance procedures, using components engineered to comply with greenhouse gas emissions and fuel efficiency regulations, may be performed by an authorized Daimler Trucks North America dealer, an independent outlet, or the vehicle owner or operator.

The vehicle owner is responsible for determining the suitability of replacement components to maintain

# Foreword

---

compliance with federal and local jurisdictional regulations. Components including, but not limited to, tires, cab/sleeper side extenders, chassis fairings, bumper, hood, vehicle speed limiters, and idle reduction timers are specifically designed and manufactured to exacting standards for regulatory fuel efficiency and greenhouse gas emissions compliance. It is important that these components are always replaced with components that meet or exceed the performance of the originally installed components.

hotline 1-800-333-0510, or contact Transport Canada by mail at: Transport Canada, ASFAD, Place de Ville Tower C, 330 Sparks Street, Ottawa, Ontario, Canada K1A 0N5.

For additional road safety information, please visit the Road Safety website at: [www.tc.gc.ca/roadsafety](http://www.tc.gc.ca/roadsafety).

## Customer Assistance Center

Having trouble finding service? Call the Customer Assistance Center at 1-800-385-4357 or 1-800-FTL-HELP. Call night or day, weekdays or weekends, for dealer referral, vehicle information, breakdown coordination, or Fleetpack assistance. Our people are knowledgeable, professional, and committed to following through to help you keep your truck moving.

## Reporting Safety Defects

If you believe that your vehicle has a defect which could cause a crash or could cause injury or death, you should immediately inform the National Highway Traffic Safety Administration (NHTSA) in addition to notifying Daimler Trucks North America LLC.

If the NHTSA receives similar complaints, it may open an investigation, and if it finds that a safety defect exists in a group of vehicles, it may order a recall and remedy campaign. However, NHTSA cannot become involved in individual problems between you, your dealer, or Daimler Trucks North America LLC.

To contact NHTSA, you may call the Vehicle Safety Hotline toll-free at 1-888-327-4236 (TTY: 1-800-424-9153); go to [www.safercar.gov](http://www.safercar.gov); or write to: Administrator, NHTSA, 1200 New Jersey Avenue, SE, Washington, DC 20590. You can also obtain other information about motor vehicle safety from [www.safercar.gov](http://www.safercar.gov).

Canadian customers who wish to report a safety-related defect to Transport Canada, Defect Investigations and Recalls, may telephone the toll-free

© 2010–2015 Daimler Trucks North America LLC. All rights reserved. Daimler Trucks North America LLC is a Daimler company.

No part of this publication, in whole or part, may be translated, reproduced, stored in a retrieval system, or transmitted in any form by any means, electronic, mechanical, photocopying, recording, or otherwise, without the prior written permission of Daimler Trucks North America LLC. For additional information, please contact Daimler Trucks North America LLC, Service Systems and Documentation, P.O. Box 3849, Portland OR 97208–3849 U.S.A. or refer to [www.Daimler-TrucksNorthAmerica.com](http://www.Daimler-TrucksNorthAmerica.com) and [www.FreightlinerTrucks.com](http://www.FreightlinerTrucks.com).

# Contents

---

| Chapter |   | Page     |
|---------|---|----------|
|         | Introduction, Environmental Concerns and Recommendations,<br>Event Data Recorder, Emissions and Fuel Efficiency Compliance,<br>Customer Assistance Center, Reporting Safety Defects ..... | Foreword |
| 1       | Vehicle Identification .....  | 1.1      |
| 2       | Vehicle Access .....  | 2.1      |
| 3       | Electrical System .....   | 3.1      |
| 4       | Instruments .....   | 4.1      |
| 5       | Driver Controls .....   | 5.1      |
| 6       | Seats and Restraints .....  | 6.1      |
| 7       | Climate Control .....   | 7.1      |
| 8       | Cab Features .....  | 8.1      |
| 9       | Engine Starting, Operation, and Shutdown .....  | 9.1      |
| 10      | Optional Engine Systems .....   | 10.1     |
| 11      | Emissions and Fuel Efficiency .....   | 11.1     |
| 12      | Brake Systems .....   | 12.1     |
| 13      | Manual Transmissions and Clutch .....   | 13.1     |
| 14      | Automated and Automatic Transmissions .....   | 14.1     |
| 15      | Drive Axles .....   | 15.1     |
| 16      | Steering System .....   | 16.1     |
| 17      | Fifth Wheels .....  | 17.1     |
| 18      | Trailer Couplings .....   | 18.1     |
| 19      | Pre- and Post-Trip Checklists .....   | 19.1     |
| 20      | Pre- and Post-Trip Inspections and Maintenance .....  | 20.1     |
| 21      | Cab Appearance .....  | 21.1     |
| 22      | Headlight Aiming .....  | 22.1     |
| 23      | In an Emergency .....   | 23.1     |
|         | Index .....   | I.1      |

# 1

## Vehicle Identification

---

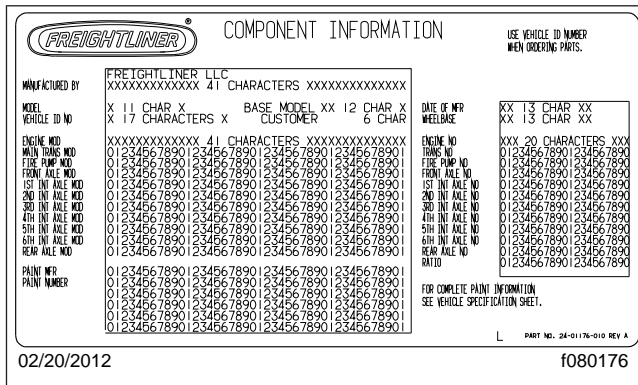
|   |     |
|---|-----|
| Component Information Label .....                   | 1.1 |
| Federal Motor Vehicle Safety Standard Labels .....  | 1.1 |
| Canadian Motor Vehicle Safety Standard Labels ..... | 1.1 |
| Component GWR Label .....                           | 1.1 |
| Emissions Labels .....                              | 1.2 |

# Vehicle Identification

## Component Information Label

**NOTE:** Labels shown in this chapter are examples only. Actual specifications may vary from vehicle to vehicle.

The component information label lists the vehicle model, identification number, and major component models. It also lists the major assemblies and installations shown on the chassis specification sheet. One copy of the component information label is attached to the inside of the glove box; another copy is inside the rear cover of the *Owner's Warranty Information for North America* booklet. An illustration of the label is shown in **Fig. 1.1**.



**Fig. 1.1, Component Information Label**

## Federal Motor Vehicle Safety Standard Labels

**NOTE:** Due to the variety of Federal Motor Vehicle Safety Standard (FMVSS) certification requirements, not all of the labels shown will apply to your vehicle.

Tractors with or without fifth wheels purchased in the U.S. are marked as certified by means of an FMVSS certification label. See **Fig. 1.3**. This label is attached to the driver-side B-pillar, as shown in **Fig. 1.4**.

The tire and rim portion of the FMVSS certification label certifies suitable tire and rim combinations that can be installed on the vehicle, for the given gross axle weight rating. Tires and rims installed on the vehicle at the time of manufacture may have a higher load capacity than that certified by the tire and rim label. If the tires and rims currently on the vehicle have a lower load capacity than that shown on the tire and rim label, then the tires and rims determine the load limitations on each of the axles.

Trucks built without a cargo body that are intended for service in the U.S. have an incomplete vehicle certification label attached by the final-stage manufacturer. See **Fig. 1.5**. This label will be attached to the incomplete vehicle document included with the vehicle, and certifies that the vehicle conforms to all applicable FMVSS regulations in effect on the date of completion.

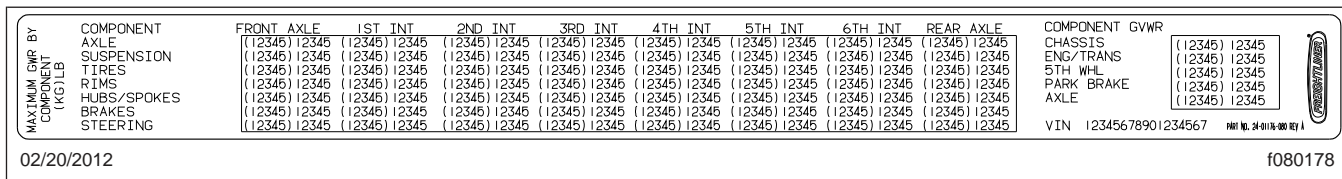
## Canadian Motor Vehicle Safety Standard Labels

In Canada, tractors with fifth wheels are marked as certified by means of a statement of compliance label with the Canadian National Safety Mark attached to the driver-side door frame B-pillar. See **Fig. 1.6**.

Trucks built without a cargo body and tractors built without a fifth wheel that are intended for service in Canada have an incomplete vehicle certification label attached to the driver-side B-pillar. After completion of the vehicle, a complete certification label must be attached by the final-stage manufacturer to certify that the vehicle conforms to all applicable Canada Motor Vehicle Safety Standard (CMVSS) regulations in effect on the date of completion.

## Component GWR Label

The component GWR label is located on the passenger-side B-pillar. The label provides maximum GWR ratings for each component.



**Fig. 1.2, Component GWR Label**

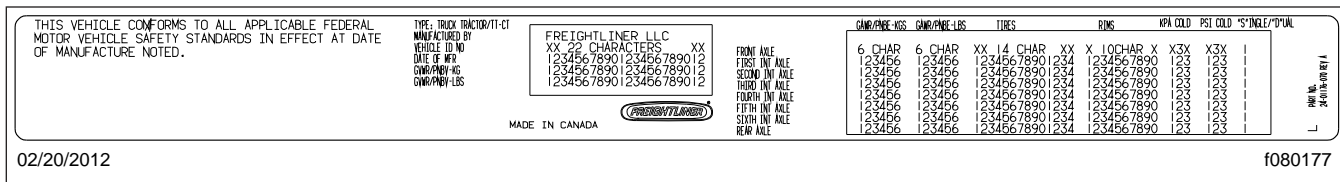


Fig. 1.3, Vehicle Certification Label

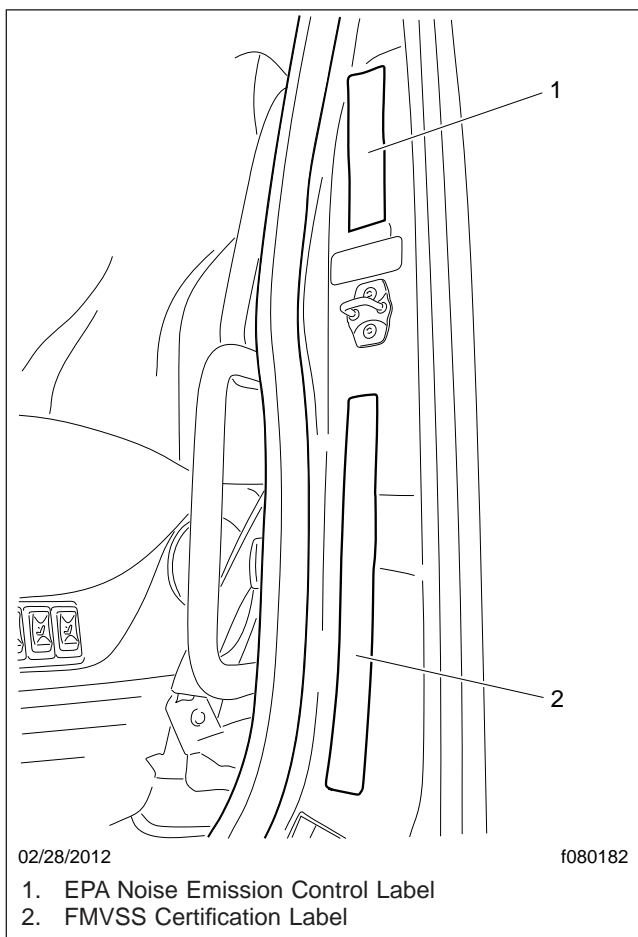


Fig. 1.4, Label Locations

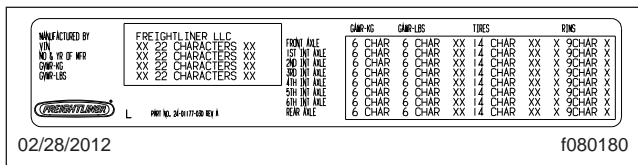


Fig. 1.5, Incomplete Vehicle Certification Label

See Fig. 1.2 for a typical component GWR label.

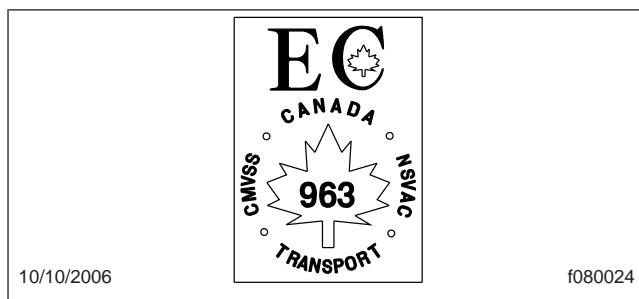


Fig. 1.6, Canadian National Safety Mark

## Emissions Labels

### Aftertreatment System Indicators Label

Engines and vehicles manufactured after December 31, 2006 and domiciled in the U.S. or Canada are required to meet all EPA regulations effective as of the vehicle build date, and are equipped with an emission aftertreatment system (ATS). Vehicles domiciled outside of the U.S. and Canada may not have aftertreatment equipment, depending upon local statutory emissions guidelines. See [Table 1.1](#).

A warning label on the driver-side visor contains important warning indicators in the instrument cluster that pertain to the ATS. See [Fig. 1.7](#).




It is a violation of U.S. federal law to alter exhaust plumbing, ATS, or other components in any way that would bring the engine/vehicle out of compliance with certification requirements [Ref: 42 U.S.C. S7522(a) (3)]. It is the owner's responsibility to maintain the vehicle so that it conforms to EPA regulations.

# Vehicle Identification

| Applicable Emissions System Based on Build Date and EPA Regulations |  |
|---|--|
| Build Date  | Regulation: Emissions Components   |
| January 1, 2010–December 31, 2012                                   | EPA10 (reduce NOx emissions to 0.2 g/bhp-hr): Aftertreatment device (ATD) containing a diesel particulate filter that traps soot and ash, with selective catalyst reduction (SCR) technology that utilizes diesel exhaust fluid (DEF) to convert NOx to nitrogen and water vapor.                      |
| From March 5, 2012  | GHG14: Aerodynamic and fuel efficiency components including, but not limited to, tires, cab/sleeper side extenders, chassis fairings, bumper, hood, vehicle speed limiters, and idle reduction timers specifically designed to meet regulatory fuel efficiency and greenhouse gas emissions standards. |

Table 1.1, Applicable Emissions System Based on Build Date and EPA Regulations

IMPORTANT

|  |   |
|--|---|
| <p>DPF Regen Needed</p>    | <ul style="list-style-type: none"> <li>Diesel Particulate Filter (DPF) regeneration is needed.</li> <li>If flashing, regenerate as soon as possible. Engine derate possible.</li> </ul> |
| <p>Hot Exhaust</p>        | <ul style="list-style-type: none"> <li>Hot exhaust can cause fire.</li> <li>Keep flammables and people away from exhaust.</li> </ul>  |
| <p>DEF Refill Needed</p>  | <ul style="list-style-type: none"> <li>Diesel Exhaust Fluid (DEF) level is low. Engine derate likely.</li> <li>Refill tank with certified DEF.</li> </ul>                               |
| <p>See operator's manual for complete instructions.</p>  |   |

24-01656-000


11/30/2010
f080162

Fig. 1.7, ATS Indicators

## EPA Noise Emission Control Label

A vehicle noise emission control label (Fig. 1.8) is located on the driver-side B-pillar as shown in Fig. 1.4. It is the owner's responsibility to maintain the vehicle so that it conforms to EPA regulations.

VEHICLE NOISE EMISSION CONTROL INFORMATION

FREIGHTLINER CORPORATION  DATE OF MANUFACTURE 01/96  
 THIS VEHICLE CONFORMS TO U.S. EPA REGULATIONS FOR NOISE EMISSION APPLICABLE TO MEDIUM AND HEAVY TRUCKS.  
 THE FOLLOWING ACTS OR THE CAUSING THEREOF BY ANY PERSON ARE PROHIBITED BY THE NOISE CONTROL ACT OF 1972:  
 A. THE REMOVAL OR RENDERING INOPERATIVE, OTHER THAN FOR PURPOSES OF MAINTENANCE, REPAIR, OR REPLACEMENT, OF ANY NOISE CONTROL DEVICE OR ELEMENT OF DESIGN (LISTED IN THE OWNER'S MANUAL) INCORPORATED INTO THIS VEHICLE IN COMPLIANCE WITH THE NOISE CONTROL ACT.  
 B. THE USE THIS VEHICLE AFTER SUCH DEVICE OR ELEMENT OF DESIGN HAS BEEN REMOVED OR RENDERED INOPERATIVE.

24-00273-000

10/06/98
f080026

Fig. 1.8, Vehicle Noise Emission Control Label

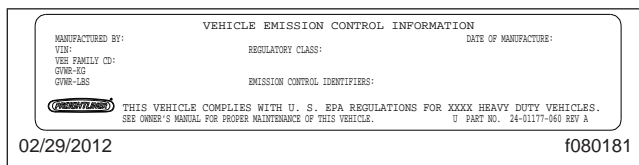


**IMPORTANT:** Certain Freightliner incomplete vehicles may be produced with incomplete noise control hardware. Such vehicles will not have a vehicle noise emission control information label. For such vehicles, it is the final-stage manufacturer's responsibility to complete the vehicle in conformity to U.S. EPA regulations (40 CFR Part 205) and label it for compliance.

## Vehicle Emission Control Information Label

Model year 2013 and later vehicles meet additional requirements as specified by federal greenhouse gas and fuel efficiency regulations (GHG14). These vehicles are equipped with components that increase fuel efficiency and reduce GHG emissions. Components may include, but are not limited to, low rolling resistance tires; aerodynamic devices such as hood, cab side extenders, and fuel tank fairings; vehicle speed limiters; and idle shutdown timers.

A Vehicle Emission Control Information Label is located on the driver-side door. See [Fig. 1.9](#). It is the owner's responsibility to maintain the vehicle so that it conforms to EPA and NHTSA regulations.

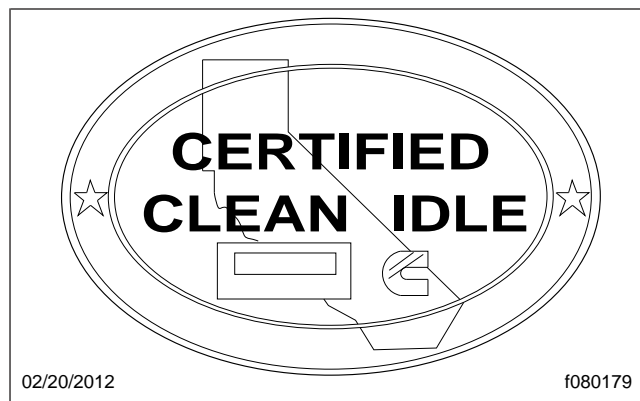


**Fig. 1.9, Vehicle Emission Control Information Label**

## Certified Clean Idle Label

The California Air Resources Board (CARB) requires model year 2008 and newer heavy-duty diesel engines to be equipped with a non-programmable engine shutdown system that automatically shuts down the engine after five minutes of idling in order to limit emissions of particulate matter and NOx.

Certified vehicles are equipped with a label placed near the bottom edge of the driver-side door. See [Fig. 1.10](#).



**Fig. 1.10, CARB Clean Idle Label**

# 2

## Vehicle Access

---

|                                     |     |
|-------------------------------------|-----|
| Cab Door Locks and Handles .....    | 2.1 |
| Grab Handles and Access Steps ..... | 2.1 |
| Cab-to-Sleeper Access .....         | 2.3 |
| Sleeper Exit Door .....             | 2.3 |
| Sleeper Luggage Door .....          | 2.4 |
| Back-of-Cab Access .....            | 2.4 |
| Hood Opening and Closing .....      | 2.5 |

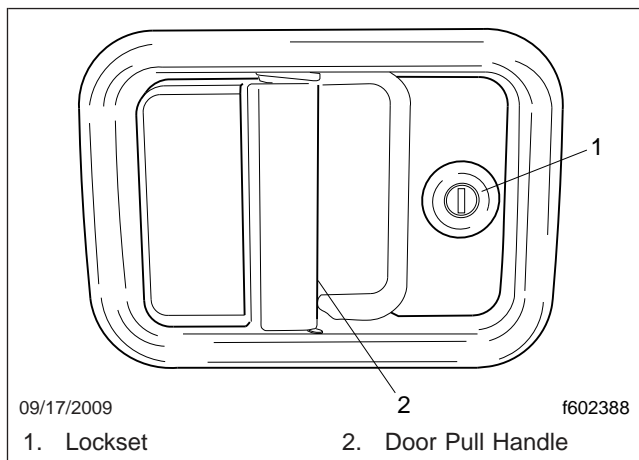
# Vehicle Access

## Cab Door Locks and Handles

One common key operates the ignition switch and all of the door locks.

**IMPORTANT:** Each key is numbered. Record the number so a duplicate key can be made, if needed.

To unlock the driver's door from outside the cab, insert the key in the lockset and turn it one-quarter turn clockwise. See [Fig. 2.1](#). To remove the key, turn it counterclockwise to the original position. Pull out on the door pull handle to open the door.



**Fig. 2.1, Exterior Door Handle**

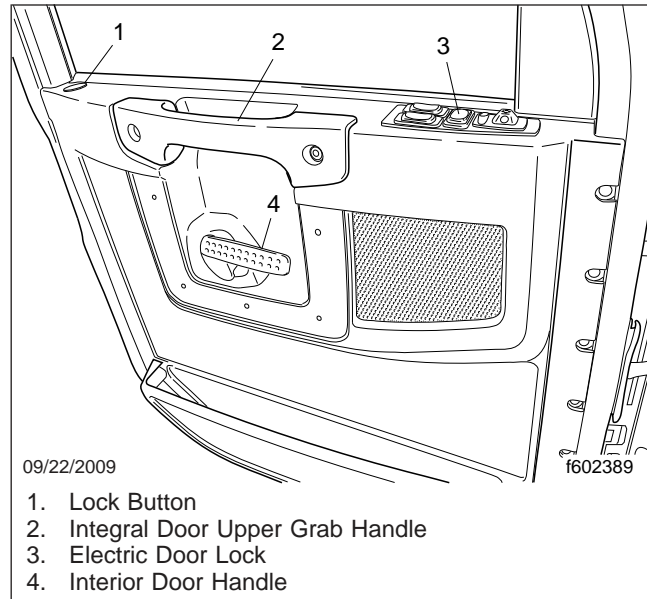
To unlock the passenger's door from outside the cab, insert the key in the lockset and turn it one-quarter turn counterclockwise. Turn the key clockwise to the original position to remove it.

**NOTE:** The cab door locks can be operated when the doors are open.

To lock a door from outside the cab, insert the key in the lockset and turn it in the direction opposite to the unlocking direction (counterclockwise for the driver's door, clockwise for the passenger's door). Close the door if it is open.

To lock either door from inside the cab, push the lock button downwards. See [Fig. 2.2](#).

To open the door from the inside, lift up on the door lever. This will unlatch the door whether or not it is locked.



**Fig. 2.2, Door Interior**

## Grab Handles and Access Steps

### **WARNING**

**Wet or dirty shoe soles greatly increase the chance of slipping or falling. If your soles are wet or dirty, be especially careful when climbing onto, or down from, the back-of-cab area.**

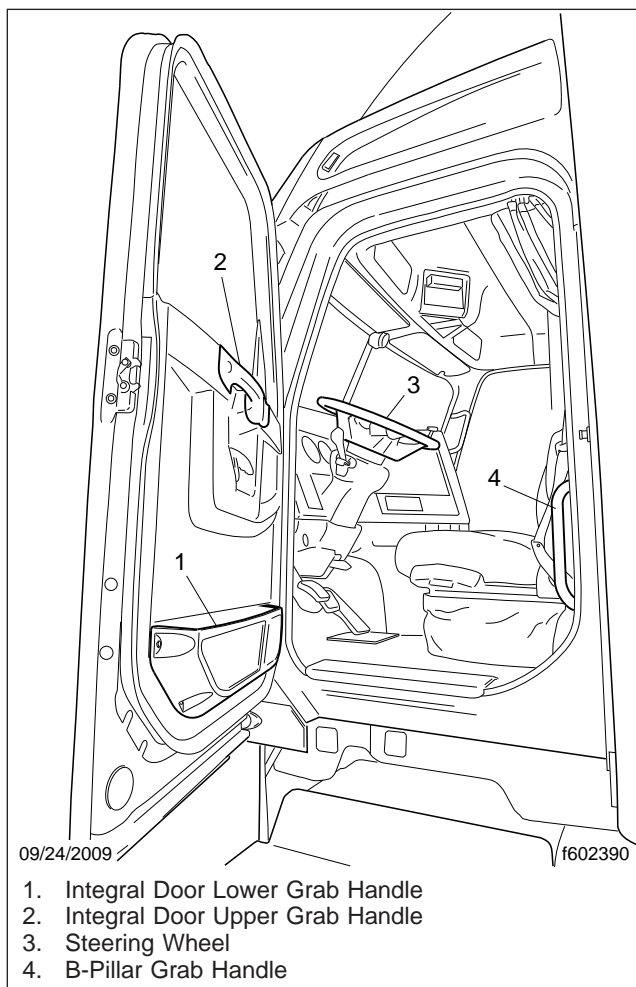
**Always maintain three-point contact with the back-of-cab access supports while entering and exiting the back-of-cab area. Three-point contact means both feet and one hand, or both hands and one foot, on the grab handles, steps, and deck plates. Other areas are not meant to support back-of-cab access, and grabbing or stepping in the wrong place could lead to a fall, and personal injury.**

**Be careful not to get hands or feet tangled in hoses or other back-of-cab equipment. Carelessness could cause a person to trip and fall, with possible injury.**

### Entering the Driver Side

When entering the cab from the driver side, use the grab handle and access steps as follows:

1. Open the driver side door, and place anything that you are carrying in the cab.
2. Using both hands, grasp the grab handle that is on the B-pillar, or use your left hand on the integral door lower grab handle. See [Fig. 2.3](#). Reach up as far as is comfortable.
3. Place your right foot on the bottom step, and pull yourself up. Move your left hand to the integral door upper grab handle.
4. Place your left foot on the top step.
5. Grasp the steering wheel with your left hand, and step up.
6. Step into the cab with your right foot first, and grasp the steering wheel with your right hand.



**Fig. 2.3, Driver-Side Steps and Grab Handle**

## Exiting the Driver Side

Exit the cab from the driver side as follows:

**IMPORTANT:** Do not attempt to exit the cab while carrying any items in your hands.

1. Grasp the steering wheel with both hands, place your left foot on the top step, then stand on the threshold facing into the cab.
2. Using your right hand, grasp the grab handle, located on the B-pillar.
3. Move your right foot to the bottom step.
4. Move your left hand to the integral door lower grab handle.
5. Step to the ground with your left foot first.

## Entering the Passenger Side

When entering the cab from the passenger side, use the grab handles and access steps as follows:

1. Open the passenger-side door, and place anything that you are carrying in the cab.
2. Using your left hand, grasp the grab handle that's on the rear of the door opening. See [Fig. 2.4](#).
3. Using your right hand, grasp the integral door lower grab handle.
4. Place your right foot on the bottom step, and step up to the upper step with your left foot.
5. Place your right foot on the top step, and step up.
6. Move your right hand to the upper grab handle on the windshield post.
7. Step into the cab with your left foot first.

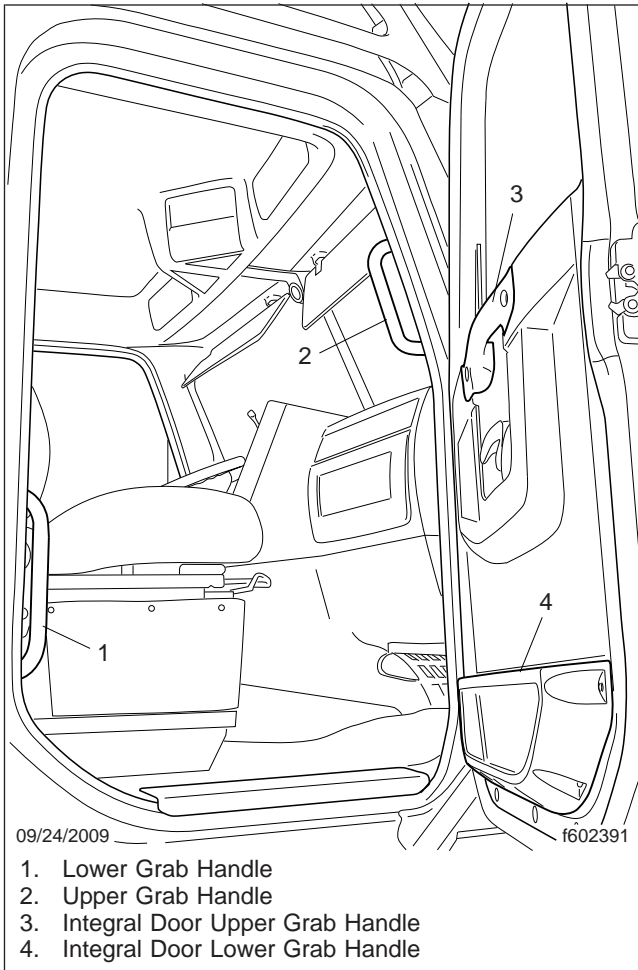
## Exiting the Passenger Side

Exit the cab from the passenger side as follows:

**IMPORTANT:** Do not attempt to exit the cab while carrying any items in your hands.

1. Using both hands, grasp the grab handle that's on the windshield post, and place your right foot on the top step while standing up from the seat facing inward.
2. Place your left foot on the bottom step.

# Vehicle Access



**Fig. 2.4, Passenger-Side Steps and Grab Handles**

3. Move your left hand to the lower grab handle located at the rear edge of the door opening. See [Fig. 2.4](#).
4. Move your right hand to the integral door lower grab handle.
5. Step to the ground with your right foot first.

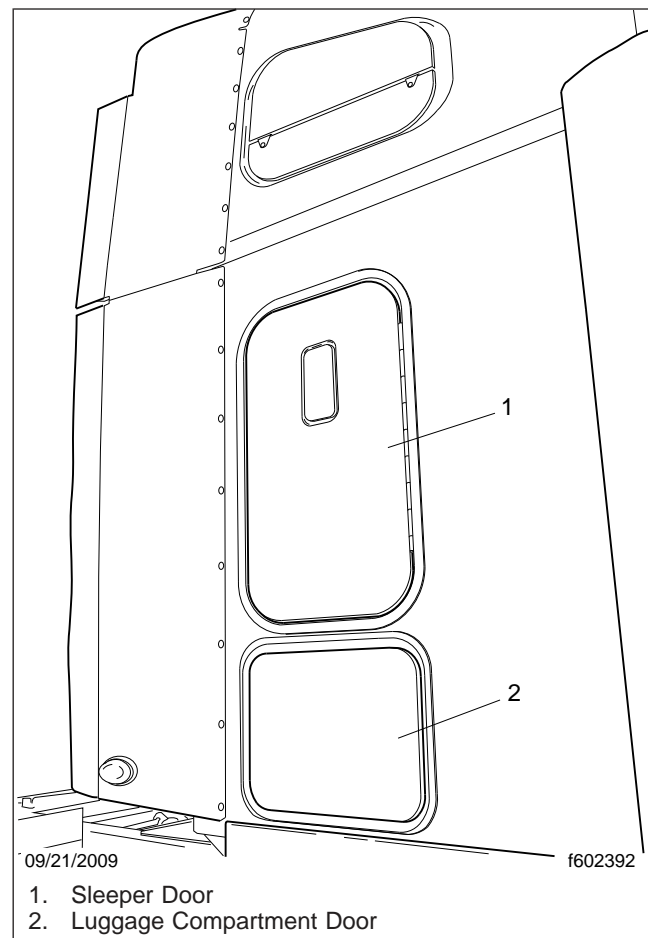
## Cab-to-Sleeper Access

To open the sleeper access on vehicles with vinyl sleeper curtains, unzip the sleeper curtains. If desired, unsnap the curtains all the way around the sides and top, and remove the curtains.

To open the sleeper access on vehicles with velour sleeper curtains, unfasten the snaps at one side, then push the curtain to the opposite side.

## Sleeper Exit Door

The sleeper door ([Fig. 2.5](#)) is not intended for entry or exit. The door is intended only as a convenient means to stow or remove personal belongings in and from the sleeper area. To open the door from inside, push down on the lever handle located inside the sleeper compartment to the right of the door. The door can be opened from the outside by first opening the baggage door, then pulling the release cable strap just inside on the left of the baggage door opening. To close the door, push it closed until it latches.



**Fig. 2.5, Sleeper Doors**

**IMPORTANT:** The sleeper doors are two-stage latching. When closing the doors, ensure that they are completely latched to prevent wind noise and water intrusion.

## Sleeper Luggage Door

To open the sleeper luggage door, pull out on the lower T-handle lever located inside the driver's side or passenger's side cab door opening. To close the door, push it closed until it latches.

## Back-of-Cab Access

### **WARNING**

External surfaces of the exhaust system remain hot after the engine has been shut down. When accessing the back of the cab or sleeper, do not touch any part of the exhaust system, or severe burns could occur.

When trailer air and electrical connections cannot be reached conveniently from the ground, Federal Motor Carrier Safety Regulations require commercial carriers to provide back-of-cab (BOC) access.

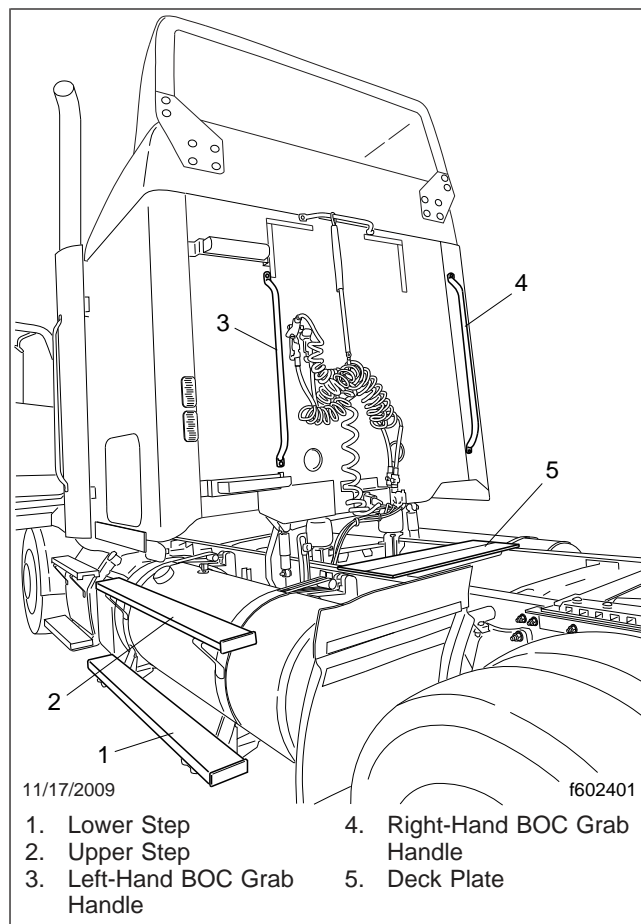
Optional grab handles are mounted either on both cab sidewalls, or on the left sidewall only. See [Fig. 2.6](#). Steps are mounted either on the fuel tank(s) or on metal brackets. When a deck plate is necessary, it is mounted across the top of the frame rails.

**IMPORTANT:** Climb onto, and down from, back-of-cab access facing in toward the vehicle, as you would on a ladder. Do not climb up or down facing out away from the vehicle.

### **WARNING**

Wet or dirty shoe soles greatly increase the chance of slipping or falling. If your soles are wet or dirty, be especially careful when climbing onto, or leaving, the back-of-cab area.

Always maintain three-point contact with the back-of-cab access supports while entering and exiting the back-of-cab area. Three-point contact means both feet and one hand, or both hands and one foot, on the grab handles, steps, and deck plates. Other areas are not meant to support back-of-cab access, and grabbing or step-



**Fig. 2.6, Back-of-Cab (BOC) Access**

ping in the wrong place could lead to a fall, and personal injury.

Be careful not to get hands or feet tangled in hoses or other back-of-cab equipment. Carelessness could cause a person to trip and fall, with possible injury.

## Climbing Up to Back-of-Cab

When climbing onto the deck plate, do the following:

1. Grasp the BOC grab handle with both hands. Reach up as far as is comfortable.
2. Place one foot on the bottom step and pull yourself up.
3. Place your other foot on the top step.

# Vehicle Access

4. Move your lower hand to a higher position on the grab handle.
5. Step onto the deck plate.

## Climbing Down from Back-of-Cab

To climb down from the back-of-cab area:

1. Grasp the BOC grab handle with both hands.
2. Step one foot at a time onto the top step.
3. Move your upper hand to a lower position on the grab handle.
4. Move one foot to the bottom step.
5. Move your upper hand to a lower position on the grab handle.
6. Step to the ground with your upper foot first.

## Hood Opening and Closing

A grab handle at the front of the hood provides a hand-hold for hood tilting. Two tilt-assist struts help to tilt the hood open, and to return it to the operating position. A damper controls the closing rate of the hood and hood straps prevent the hood from over-travel. In the operating position, the hood is secured by a hold-down latch on each side of the hood.

### To Tilt the Hood

1. Apply the parking brakes.
2. Release both hood hold-down latches by pulling the ends outward.

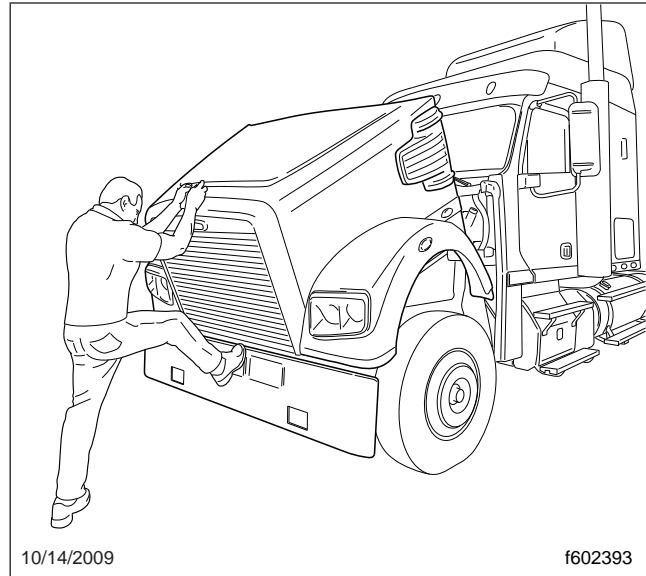
### NOTICE

**Do not let the hood free-fall to the full-open position. To do so could cause damage to the hood or hood straps.**

3. Using the bumper step and grab handle, slowly tilt the hood until the straps support it. See [Fig. 2.7](#).

### To Return the Hood

1. Grasp the grab handle, and lift the hood to the just-over-center position.



**Fig. 2.7, Hood Tilting**

2. Make sure the hood is flush with the cowl, then secure the hood by engaging both hood hold-down latches.

**IMPORTANT:** Make sure that both hold-down latches are fully engaged before operating the vehicle.

# 3

## Electrical System

---

|                            |     |
|----------------------------|-----|
| Vehicle Power Supply ..... | 3.1 |
|----------------------------|-----|



# Electrical System

## Vehicle Power Supply

### **⚠ WARNING**

Do not attempt to modify, add, splice, or remove electrical wiring on this vehicle. Doing so could damage the electrical system and result in a fire that could cause serious personal injury or property damage.

## Power Distribution

There are four power distribution modules in the vehicle: the main power distribution module (PDM), the auxiliary PDM, the powertrain PDM, and the power-net distribution box (PNDB).

The main PDM contains the circuit breakers and fuses required to protect the vehicle. It is located in the top of the right-hand dash, and is accessed by removing the four fasteners in the top of the dash panel.

The auxiliary PDM is located on the B-pillar access door, behind the driver's seat. It controls power to the HVAC system, the sleeper, and anti-lock braking.

The powertrain PDM is mounted off the driver's-side frontwall in the engine compartment. It controls power to the engine, aftertreatment system, transmission, and other powertrain-related circuits.

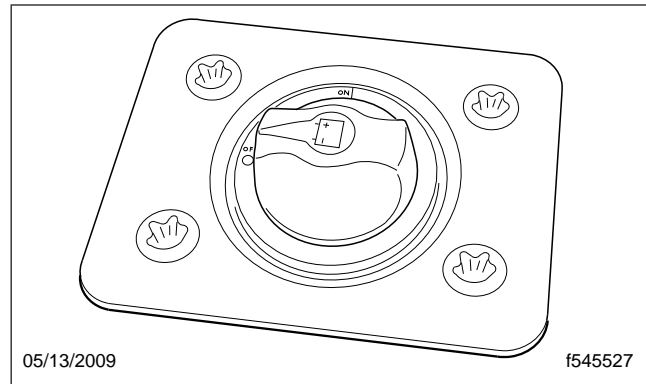
The PNDB is mounted on the cab frontwall near the steering column. It supplies power to the powertrain PDM, the main PDM and other cab functions, including the clock.

## Load Disconnect Switch

### **⚠ WARNING**

**Turning the load disconnect switch to the OFF position does not disconnect the connection between the battery and the starter. To work on the vehicle safely, the negative leads must be disconnected from the battery.**

The load disconnect switch is used to avoid excessive draw on the battery when the vehicle is parked for an extended period of time. See [Fig. 3.1](#). When the load disconnect switch is set to OFF, it signals the PNDB to disconnect battery power to powertrain and accessory loads. The power to the



**Fig. 3.1, Load Disconnect Switch**

aftertreatment-system control module is disconnected after the DEF purge function is completed.

The load disconnect switch is mounted in one of two locations:

- inside the cab on the left side of the driver's seat (left-hand-drive vehicle);
- on the battery box

**IMPORTANT:** The ignition should be turned OFF before turning the load disconnect switch to ON or OFF.

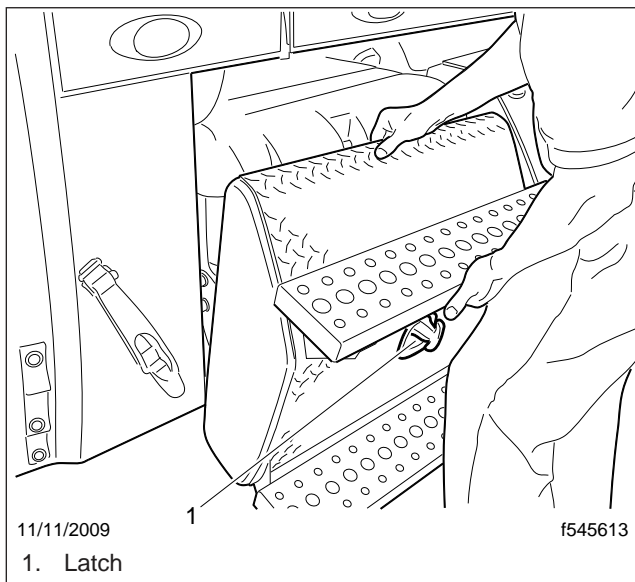
## Low Voltage Disconnect, Optional

The optional Sure Power Low Voltage Disconnect (LVD) system monitors battery power when accessories are being used while the engine is shut down. The system automatically turns off cab and sleeper accessories when voltage drops to 12.3 volts, to ensure that there is enough battery power to start the vehicle. An alarm sounds for one minute before accessories are turned off. If no action is taken within that minute, the LVD module will shut off power to predetermined cab and sleeper circuits. These circuits will remain off until the LVD measures 13.0 volts applied to the system, which can be achieved by starting the engine. After the engine is started, the system will reset.

Vehicles are equipped with an LVD label on the drivers-side sun visor, indicating the presence of the system.

## Battery Access

The batteries may be located below the driver's door, underneath the steps. To access the batteries located under the steps, turn the latch on the front of the battery-box cover clockwise to release the catch, then lift the cover and step assembly upwards and outwards to expose the plastic battery box. Release the catch on the plastic cover, then remove it to access the batteries. See [Fig. 3.2](#).



**Fig. 3.2, Battery Compartment (under driver's door)**

# 4

## Instruments

---

|                                     |      |
|-------------------------------------|------|
| Instrumentation Control Units ..... | 4.1  |
| Warning and Indicator Lights .....  | 4.1  |
| Standard Instruments .....          | 4.8  |
| Optional Instruments .....          | 4.10 |
| Driver Message Center .....         | 4.11 |
| Roll Stability System .....         | 4.25 |
| Overhead Instrument Panel .....     | 4.27 |

# Instruments

---

## Instrumentation Control Units

The instrument control unit (ICU) provides the driver with engine and vehicle information. It is comprised of standard and optional gauges, an audible warning, a driver message center, and a lightbar containing warning and indicator lamps (also known as telltales). Warning and indicator lamps illuminate in red (danger), amber (caution), green (status advisory), or blue (high-beam headlights active).

122SD and Coronado vehicles are equipped with an ICU4, ICU4M, or ICU4Me. See [Fig. 4.1](#), [Fig. 4.2](#), and [Fig. 4.3](#) for typical ICU layouts.

The following headings in this chapter provide additional information and operating instructions for ICU components:

- "Warning and Indicator Lights"
- "Standard Instruments"
- "Optional Instruments"
- "Driver Message Center"

## Ignition Sequence

When the ignition is turned on, the ICU runs a self-check. Observing the ignition sequence is a good way to ensure the ICU is functioning properly.

**IMPORTANT:** Do not crank the engine until the ICU self-check is complete.

**NOTE:** Air gauges do not complete a sweep of their dials during the ignition sequence.

When the ignition is turned on, the following actions should occur:

- electronic gauges complete a full sweep of their dials
- warning and indicator lamps illuminate, then are extinguished
- audible alert sounds for approximately four seconds or until sufficient air pressure builds up in the primary and secondary air systems
- DEF level indicator illuminates all segments green, then turns them off one at a time before turning the leftmost segment amber and then red
- Freightliner logo displays on the ICU4Me driver message center for two seconds.

- software revision level of the ICU is displayed under the Freightliner logo on the driver message center, followed by any active faults

**NOTE:** If active faults are present, take the vehicle to an authorized Freightliner service facility as soon as possible.

If the ICU receives active fault codes, it displays them one after the other until the parking brake is released or the ignition is turned off. Once the parking brake is completely released, the ICU displays the odometer. If there are no active faults, the ICU displays the odometer after the self-check completes.

When the self-check is complete on an ICU4M, the fasten seat belt screen displays if the engine is off. If the engine is running, the idle hours screen displays.

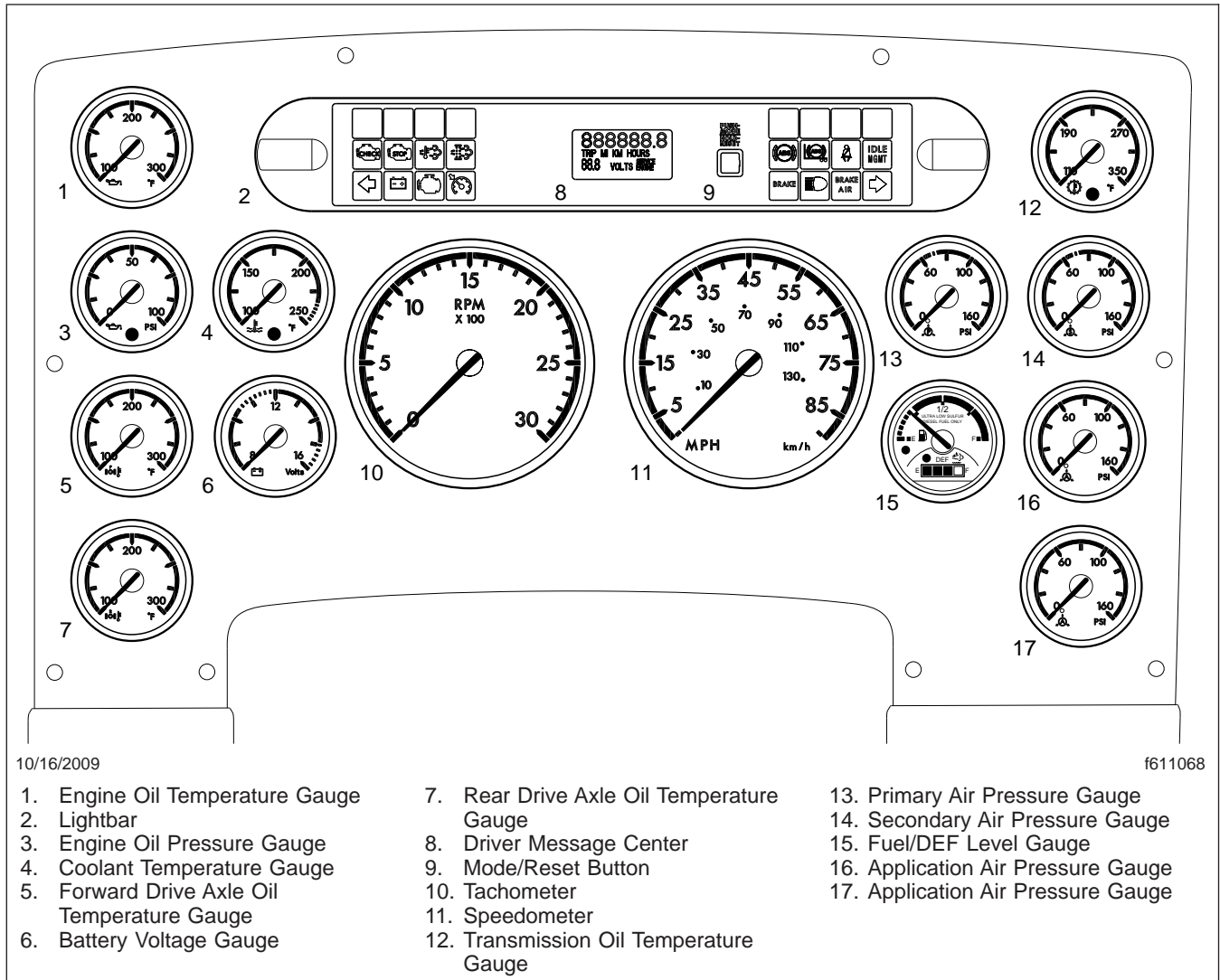
## Audible Alerts

An audible alert sounds during the ignition sequence and whenever one of the following conditions exists:

- Engine oil pressure falls below the minimum preset value.
- Coolant temperature rises above the maximum preset value.
- Air pressure falls below approximately 70 psi (483 kPa).
- Parking brake is set with the vehicle moving faster than two miles per hour.
- System voltage falls below 12 volts.
- Door is open with the parking brake off.
- Headlights are on with the door open and the ignition off.
- Occupied seat belts are not fastened and the parking brake is not set (optional).
- Outside temperature falls below 35°F (1.7°C) (optional).

## Warning and Indicator Lights

The ICU lightbar has three to four rows of warning and indicator lights with icon symbols (also known as telltales). The positions of the lights may vary for the different ICUs, but the symbols are standard for all applications. See [Table 4.1](#) for a listing of standard and commonly used warning and indicator lamps.



**Fig. 4.1, Typical ICU4 Layout**

Warning and indicator lamps illuminate in red (danger), amber (caution), green (status advisory), or blue (high-beam headlights active).

**IMPORTANT:** Depending upon local jurisdictional emissions guidelines, vehicles and/or engines that are domiciled outside of the U.S. and Canada may not be compliant with EPA10 or GHG14 regulations. Noncompliant vehicles may not be equipped with all of the lamps shown in [Table 4.1](#).

**IMPORTANT:** If any red or amber warning and indicator lamps do not illuminate during the ICU self-check or do not go out after the self-check completes, take the action outlined in [Table 4.1](#), or take the vehicle to an authorized Freightliner service facility as soon as possible.

# Instruments

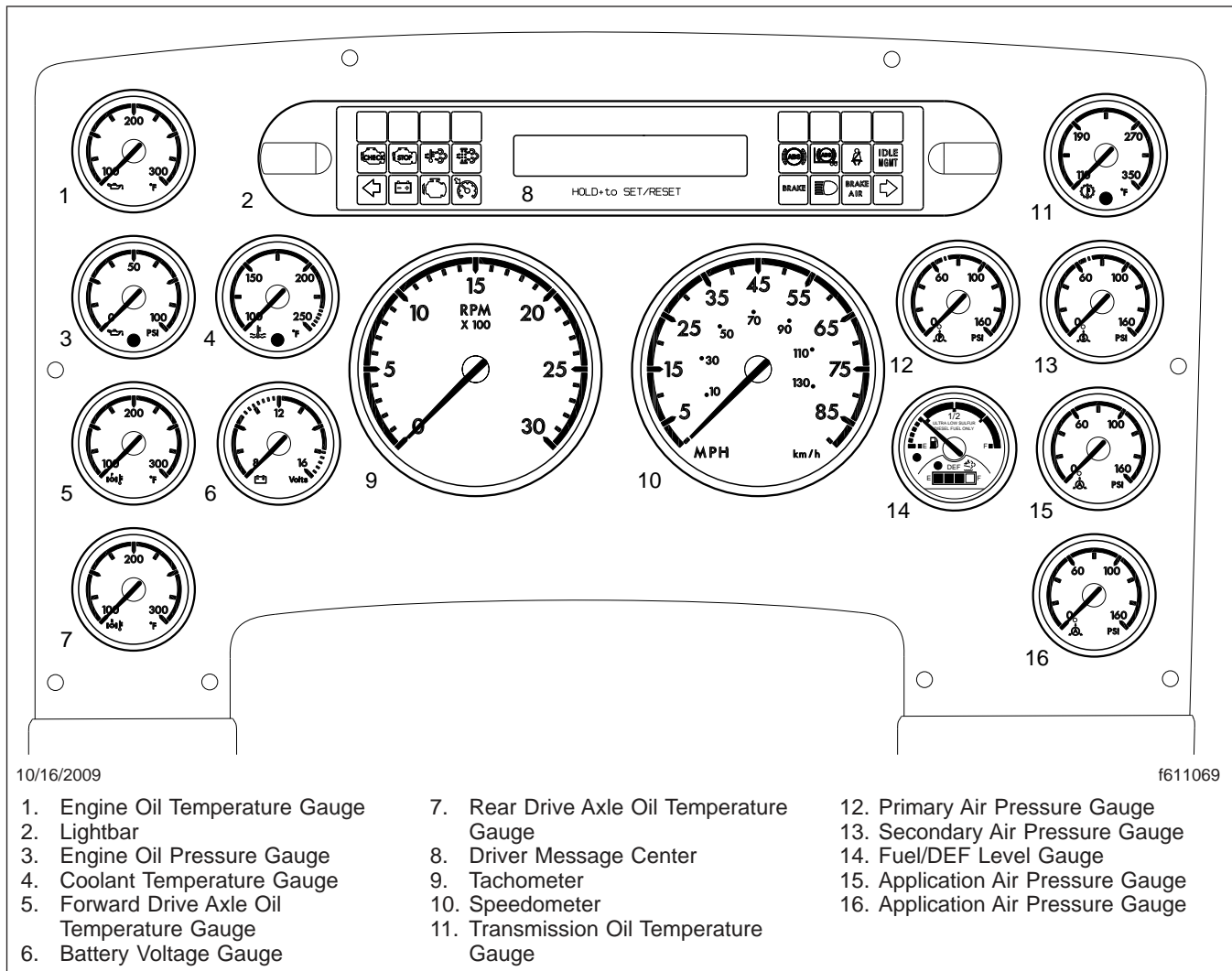
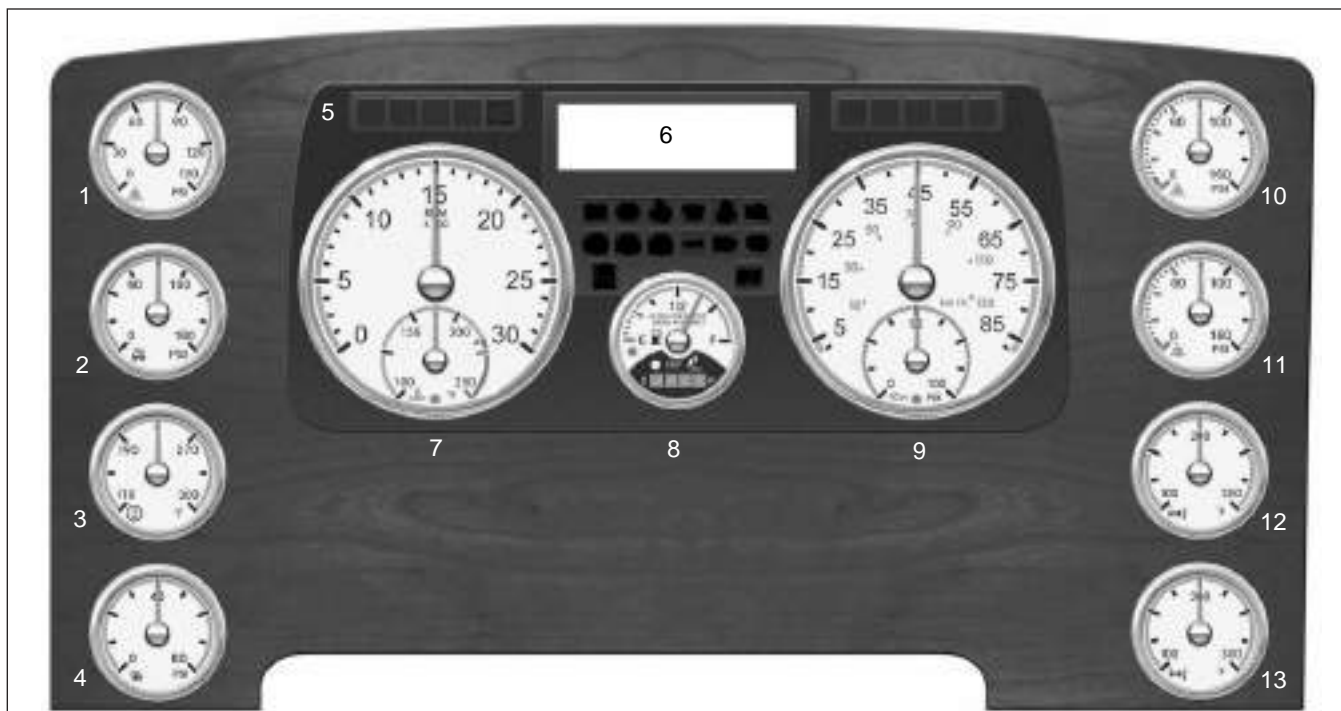


Fig. 4.2, Typical ICU4M Layout




02/20/2013












f611204

- |                                       |  |                                  |
|---------------------------------------|--|----------------------------------|
| 1. Application Air Pressure Gauge     | 6. Driver Message Center                     | 10. Primary Air Pressure Gauge   |
| 2. Suspension Air Pressure Gauge      | 7. Tachometer and Coolant Temperature Gauge  | 11. Secondary Air Pressure Gauge |
| 3. Transmission Oil Temperature Gauge | 8. Fuel/DEF Level Gauge                      | 12. Front Axle Temperature Gauge |
| 4. Turbo Pressure Gauge               | 9. Speedometer and Engine Oil Pressure Gauge | 13. Rear Axle Temperature Gauge  |
| 5. Lightbar                           |  |                                  |











**Fig. 4.3, ICU4Me Instrument Cluster**

| Common Warning and Indicator Lamps  |  |       |
|---|--|-------|
|   | Lamp Description   | Color |
|  | <p><b>STOP Engine*</b></p> <p>Indicates a serious fault that requires engine shutdown immediately. The engine protection system will reduce the maximum engine torque and speed, and, if the condition does not improve, will shut down the engine within 30 to 60 seconds.</p> <p>Safely bring the vehicle to a stop on the side of the road and shut down the engine as soon as the red light is seen. <b>If the engine shuts down while the vehicle is in a hazardous location, turn the key to the OFF position for a few seconds, then restart the engine and move the vehicle to a safer location.</b></p> | Red   |








# Instruments

| Common Warning and Indicator Lamps  |  |   |       |
|---|--|---|-------|
| Lamp Description  |  |   | Color |
|    | High Coolant Temperature                 | Indicates the coolant temperature is above the maximum allowable temperature.   | Red   |
|    | Low Air Pressure                         | Indicates air pressure in the primary or secondary reservoir has dropped below approximately 70 psi (483 kPa).  |       |
|    | Low Engine Oil Pressure                  | Indicates the engine oil pressure is below the minimum allowable pressure.  |       |
|    | Transmission Overheat                    | Indicates high transmission temperature.  |       |
|    | Parking Brake                            | Indicates the parking brake is engaged.   |       |
|   | Low Battery Voltage                      | Indicates that battery voltage is 11.9 volts or less.   |       |
|  | Unfastened Seat Belt                     | Activates with an audible alert when the system detects that the parking brake is off and the driver seat belt is not fastened on some vehicles. On other vehicles, this lamp illuminates for 15 seconds when the ignition is first turned on.  |       |
|  | CHECK Engine *                           | Indicates an engine condition (low oil pressure, low coolant level, high coolant temperature, high DPF soot level, or uncontrolled DPF regeneration) that requires correction. Correct the condition as soon as possible. If the condition worsens, the STOP engine lamp will illuminate.   | Amber |
|  | High Exhaust System Temperature (HEST) * | Slow (10-second) flashing indicates a regeneration (regen) is in progress.<br><b>IMPORTANT: When the HEST lamp is illuminated, do not park the vehicle near flammable material.</b>   |       |
|  | Diesel Particulate Filter (DPF) Status   | Solid illumination indicates high exhaust temperatures at the outlet of the tail pipe when speed is below 5 mph (8 km/h).<br>Solid illumination indicates a regen is required. Change to a more challenging duty cycle (such as highway driving ) to raise exhaust temperatures for at least twenty minutes, or perform a parked regen. |       |
|  | Malfunction Indicator Lamp (MIL)         | Blinking indicates that a parked regen is required immediately. An engine derate and shutdown will occur.   |       |
|   |  | Indicates an emissions-related fault. See the engine operation manual for details.  |       |



| Common Warning and Indicator Lamps  |                         |  |       |
|---|-------------------------|--|-------|
| Lamp Description  |                         |  | Color |
|    | Vehicle ABS             | <p>Momentary illumination indicates the vehicle ABS is engaged.</p> <p>Solid illumination indicates a problem with the vehicle ABS. Repair the ABS immediately to ensure full braking capability.</p>  | Amber |
|    | Trailer ABS             | <p>Momentary illumination indicates the trailer ABS is engaged.</p> <p>Solid illumination indicates a problem with the trailer ABS. Repair the ABS immediately to ensure full braking capability.</p>  |       |
|    | No Charge               | Indicates the alternator is not properly powering the electrical system.   |       |
|    | Water in Fuel           | Indicates the fuel may contain water. Drain any water collected in the fuel/water separators.  |       |
|   | Fuel Filter Restriction | Indicates the fuel filter is clogged and requires service.   |       |
|  | Optimized Idle          | Indicates optimized idle is enabled.   |       |
|  | Check Transmission      | Indicates an undesirable transmission condition.   |       |
|  | Wait To Start (EPA10)   | <p>Indicates that the system is preventing the starter from cranking. This can occur when the ignition switch is turned to START before the gauge sweep has completed, or if the starter has overheated.</p> <p>Turn the ignition switch back to ON, wait for the lamp to go out, then turn the ignition switch to START again.</p>  |       |
|  | Start Blocked (GHG14)   | <p>Indicates that the system is preventing the starter from cranking. This can occur when the ignition switch is turned to START before the gauge sweep has completed, or if the starter has overheated.</p> <p><b>NOTE: Illumination of the Start Blocked lamp does not indicate a problem with the starter.</b></p> <p>Turn the ignition switch back to ON, wait for the lamp to go out, then turn the ignition switch to START again.</p> |       |
|  | Wheel Spin              | <p>Flashing indicates the ATC system is active, or the ATC button has been pressed to allow wheel slip.</p> <p>Solid illumination indicates a problem with the ATC system. Repair the ATC system immediately to ensure full braking capability.</p>  |       |

# Instruments

| Common Warning and Indicator Lamps  |   |       |      |
|---|---|-------|------|
| Lamp Description  |   | Color |      |
|    | Roll Stability  | Amber |      |
|   | Momentary illumination indicates that a stability event has occurred.<br>On vehicles that are also equipped with ATC, flashing indicates the ATC button has been pressed to allow wheel slip. |       |      |
|    | Hill Start Aid (HSA) Override   | Green |      |
|   | Indicates the HSA switch has been pressed to override the hill start assist feature.  |       |      |
|    | Engine Brake  |       | Blue |
|   | Indicates the engine brake is enabled.  |       |      |
|    | Left-Turn Signal  |       |      |
|    | Right-Turn Signal   | Blue  |      |
|   | Flashing indicates the outside right-turn signal lights are activated.  |       |      |
|  | Cruise Control  | Blue  |      |
|   | Indicates the cruise control is enabled.<br>NOTE: The ICU4Me does not have a green cruise control telltale.   |       |      |
|  | High-Beam Headlights  | Blue  |      |
|   | Indicates the high-beam headlights are on.  |       |      |

\* See Fig. 4.4 for an explanation of the aftertreatment system (ATS) warning indicators, and actions required to avoid further engine protection steps.

**Table 4.1, Common Warning and Indicator Lamps**

## Engine Protection System



When the red STOP engine lamp illuminates, most engines are programmed to shut down automatically within 30 seconds. The driver must immediately move the vehicle to a safe location at the side of the road to prevent causing a hazardous situation that could cause bodily injury, property damage, or severe damage to the engine.







See Fig. 4.4 for an explanation of the aftertreatment system (ATS) warning indicators, and actions required to avoid further engine protection steps.

The STOP engine lamp illuminates when the engine protection system is activated in one of two ways. On some engines, the engine protection system will der-

ate the engine, allowing it to run at lower rpm and slower vehicle speed. Drive the vehicle to a safe location or to a service facility.

**IMPORTANT:** Safely bring the vehicle to a stop on the side of the road and shut down the engine as soon as the red light is seen. If the engine shuts down while the vehicle is in a hazardous location, turn the key to the OFF position for a few seconds, then restart the engine and move the vehicle to a safer location.

On other engines, the engine protection system will shut down the engine. It will first derate the engine, then shut it down completely 30 to 60 seconds after the indicator illuminates (depending on the critical fault type) if the condition does not improve. Bring the vehicle to a stop on the side of the road before the engine shuts down.

| EXHAUST AFTERTREATMENT SYSTEM INFORMATION   |  |   |   |  |  |
|---|--|---|---|--|--|
| INDICATOR LAMP(S)   |  (Solid)<br>Level 1     |  (Flashing)<br>Level 2   |  (Flashing) CHECK<br>Level 3 |  STOP<br>Level 4                                      |  WARNING<br> |
| Indicator Lamp Message(s)   | Filter Regeneration Recommended.   | Filter Regeneration Necessary   | Parked Regeneration Required – Engine Derate  | Service Regeneration Required. Engine Derate To Idle Only.   | HEST (High Exhaust System Temperature)   |
| Diesel Particulate Filter Condition   | Filter is reaching capacity.   | Filter is now reaching maximum capacity.  | Filter has reached maximum capacity.  | Filter has exceeded maximum capacity.  | <b>Flashing</b><br>A regeneration is in progress.  |
| Required Action   | Bring vehicle to highway speeds to allow for an Automatic Regeneration or perform a Parked Regeneration. | To avoid engine derate, bring vehicle to highway speeds to allow for an Automatic Regeneration, or perform a Parked Regeneration as soon as possible. | Vehicle must be parked, and a Parked Regeneration must be performed. Engine will begin derate.                | Vehicle must be parked, and a Service Regeneration must be performed. Check engine operator's manual for details. Engine will shut down. | <b>Solid</b><br>Exhaust components and exhaust gas are at high temperature. When stationary, keep away from people and flammable materials or vapors.                              |
| For a driver performed Parked Regeneration, vehicle must be equipped with a dash mounted Regeneration Switch. |  |   |   |  |  |

02/20/2009

f080156

Fig. 4.4, ATS Warning Lamps

Some vehicles may have a shutdown-override switch, which may be used to momentarily override the shutdown sequence. See [Chapter 10](#) for detailed information regarding the shutdown process.

**IMPORTANT:** Do not attempt to restart the engine while the vehicle is moving. Bring the vehicle to a safe stop, then restart the engine.

To restart the engine, turn the ignition to OFF, leave it there a few seconds, then turn the ignition to START. The engine will run for a short period and shut down again if the condition does not improve.

## Standard Instruments

Standard instruments are present on every vehicle. They are listed here in alphabetical order, to make the information easier to find.

Some gauges have an LED warning light that indicates when values have exceeded their preset minimum or maximum values.

Gauges with a warning light include:

- engine coolant temperature;
- engine oil pressure;

- fuel and DEF level;
- transmission fluid temperature;
- voltmeter.

## Coolant Temperature Gauge

### NOTICE

**A sudden increase in coolant temperature may indicate engine or cooling system failure. Bring the vehicle to a safe stop and investigate the cause to prevent further damage. Do not operate the engine until the cause has been determined and corrected.**

During normal engine operation, the coolant temperature gauge should read between 175 and 195°F (79 and 91°C). If the temperature remains below 160°F (71°C) or exceeds the maximum temperature shown in [Table 4.2](#), inspect the cooling system to determine the cause.

| Maximum Coolant Temperature |                      |
|-----------------------------|----------------------|
| Engine Make                 | Temperature: °F (°C) |
| Cummins                     | 225 (107)            |

# Instruments

| Maximum Coolant Temperature |                      |
|-----------------------------|----------------------|
| Engine Make                 | Temperature: °F (°C) |
| Detroit Diesel              | 215 (101)            |

Table 4.2, Maximum Coolant Temperature

## Engine Oil Pressure Gauge

### NOTICE

A sudden decrease or absence of oil pressure may indicate mechanical failure. Bring the vehicle to a safe stop and investigate the cause to prevent further damage. Do not operate the engine until the cause has been determined and corrected.

The engine oil pressure gauge displays the current engine oil pressure. If engine oil pressure falls below the minimum levels shown in Table 4.3, the CHECK engine lamp will illuminate. If the condition does not improve, the STOP engine lamp will illuminate and an audible warning will sound. The engine will then derate or shut down, depending on the type of engine protection system installed.

| Minimum Engine Oil Pressure* |                             |                            |
|------------------------------|-----------------------------|----------------------------|
| Engine Model                 | At Idle Speed:<br>psi (kPa) | At Rated RPM:<br>psi (kPa) |
| Cummins                      | 15 (103)                    | 35 (241) min.              |
| Detroit Diesel               | 14 (97) min.                | 55 (350) min.              |

\* Pressures apply with the engine at operating temperature. Oil pressure may be higher on a cold engine. Observe and record pressures when the engine is new to create a guide for checking engine condition.

Table 4.3, Minimum Engine Oil Pressure

## Fuel/Diesel Exhaust Fluid (DEF) Gauge

The fuel and DEF levels are measured in a dual purpose fuel/DEF gauge. See Fig. 4.13.

The diesel fuel level is indicated at the top of the gauge, with a low-fuel warning lamp that illuminates when the diesel fuel level registers 1/8th of capacity.

The DEF level is indicated in the lightbar on the lower portion of the gauge. There is a low DEF level warning lamp that illuminates when the DEF level reaches 10% of capacity. See Chapter 11 for details of the exhaust aftertreatment system.

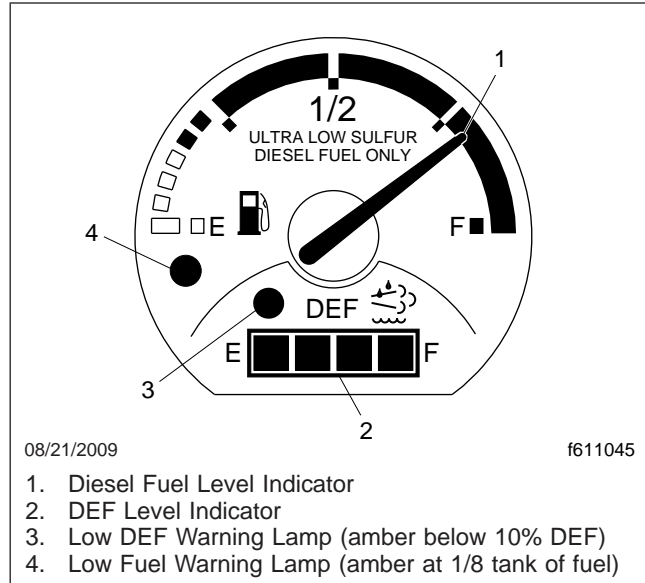


Fig. 4.5, Fuel/DEF Gauge

## Primary and Secondary Air Pressure Gauges

### WARNING

If air pressure falls below minimum pressure, the braking ability of the vehicle will be limited. Slow the vehicle down and bring it to a gradual stop. Do not attempt to move the vehicle until air pressure has risen above the minimum level. Moving a vehicle without adequate braking power could cause an accident resulting in property damage, personal injury, or death.

Air pressure gauges register the pressure in the primary and secondary air systems. Normal pressure with the engine running is 100 to 120 psi (689 to 827 kPa) in both systems.

A low air pressure warning lamp and audible warning, connected to both the primary and secondary systems, activate when air pressure in either system drops below a minimum pressure of 64 to 76 psi (441 to 524 kPa).

When the engine is started, the warning light and buzzer remain on until air pressure in both systems exceeds minimum pressure.

## Speedometer

Two speedometer face options are available. The U.S. version of the speedometer registers speed in both miles per hour (mph) and kilometers per hour (km/h), with mph in larger numbers.

The metric version of the speedometer face reverses this arrangement, with km/h in larger numbers.

## Tachometer

The tachometer indicates engine speed in revolutions per minute (rpm) and serves as a guide for shifting the transmission and keeping the engine in the appropriate rpm range. For low idle and rated rpm, see the engine identification plate.

## Voltmeter

The voltmeter indicates the vehicle charging system voltage when the engine is running and the battery voltage when the engine is stopped. By monitoring the voltmeter, the driver can stay aware of potential battery charging problems and have them fixed before the batteries discharge enough to create starting difficulties.

The voltmeter will normally show approximately 13.7 to 14.1 volts when the engine is running. The voltage of a fully charged battery is 12.7 to 12.8 volts when the engine is stopped. A completely discharged battery will produce only about 12.0 volts. The voltmeter will indicate lower voltage as the vehicle is being started or when electrical devices in the vehicle are being used.

If the voltmeter shows an undercharged or overcharged condition for an extended period, have the charging system and batteries checked at a repair facility.

On a vehicle equipped with a battery isolator system, the voltmeter measures the average voltage of all the batteries when the engine is running. When the engine is stopped, the voltmeter shows only the gel cell battery voltage and does not indicate the voltage of the engine-starting batteries.

## NOTICE

**Gel cell batteries can be damaged if the battery voltage is allowed to drop below 12.0 volts or if the charging voltage is more than 14.1 volts. Start the engine to recharge the gel cell before**

**the battery becomes fully discharged. If an external charger is needed, disconnect the gel cell battery and use only an external battery charger that has been approved for gel cell batteries.**

## Optional Instruments

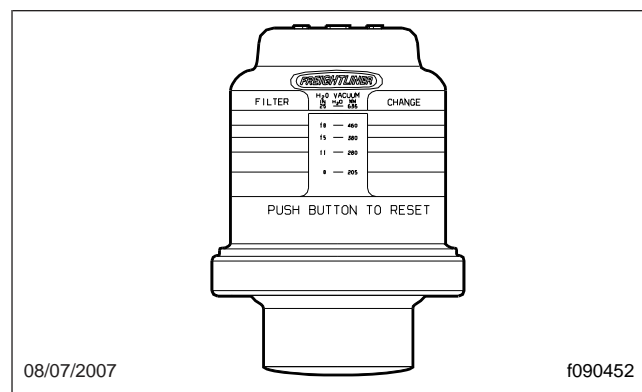
Optional instruments are not found on every vehicle. They are listed here in alphabetical order, to make the information easier to find.

## Air Restriction Gauge

The air intake restriction gauge measures the vacuum on the engine side of the air cleaner. On standard installations, it is mounted on the air intake duct in the engine compartment. As an option for easier viewing, an air intake restriction gauge may be located in the ICU.

**NOTE:** Rain or snow can wet the air filter, causing a temporarily higher than normal reading.

Air intake restriction vacuum is measured in inches of water (inH<sub>2</sub>O). For vehicles equipped with a graduated indicator (see [Fig. 4.6](#)) or a restriction gauge on the dash, check the gauge with the engine off. If the air restriction value equals or exceeds the value shown in [Table 4.4](#), the air cleaner element needs to be replaced.



**Fig. 4.6, Manual-Reset Air Restriction Indicator with Graduations**

| Maximum Air Intake Restriction Values |                            |                            |
|---------------------------------------|----------------------------|----------------------------|
| Engine Make                           | Initial inH <sub>2</sub> O | Service inH <sub>2</sub> O |
| Cummins                               | 10                         | 25                         |

# Instruments

---

| Maximum Air Intake Restriction Values |                            |                            |
|---------------------------------------|----------------------------|----------------------------|
| Engine Make                           | Initial inH <sub>2</sub> O | Service inH <sub>2</sub> O |
| Detroit Diesel                        | 10                         | 22                         |

Table 4.4, Maximum Air Intake Restriction Value

## Brake Application Air Pressure Gauge

The application air pressure gauge registers the air pressure being used to apply the brakes, and should be used for reference only. The gauge will not register until the foot pedal is depressed or the hand brake lever is applied.

## Drive Axle Oil Temperature Gauges

---

### NOTICE

---

**A sudden increase in oil temperature that is not caused by a load increase may indicate mechanical failure. Bring the vehicle to a safe stop and investigate the cause to prevent further damage. Do not operate the vehicle until the cause has been determined and corrected.**

During normal operation, drive axle oil temperature gauges should read as follows:

- 160 to 220°F (71 to 104°C) for Detroit™ and Meritor™ drive axles
- 180 to 200°F (82 to 93°C) for Dana Spicer® drive axles

Under heavy loads, such as when climbing steep grades, temperatures that exceed the normal oil temperature range for a short period are not unusual. If the temperature returns to normal when the load decreases, there is no problem.

## Engine Oil Temperature Gauge

---

### NOTICE

---

**A sudden increase in oil temperature that is not caused by a load increase may indicate mechanical failure. Bring the vehicle to a safe stop and investigate the cause to prevent further damage. Do not operate the engine until the cause has been determined and corrected.**

During normal operation, the engine oil temperature gauge should read from 200 to 260°F (93 to 126°C).

Under heavy loads, such as when climbing steep grades, temperatures that exceed the normal oil temperature range for a short period are not unusual. If the temperature returns to normal when the load decreases, there is no problem.

## Transmission Fluid Temperature Gauge

The transmission fluid temperature gauge measures the transmission lubricant operating temperature. Transmission temperatures vary by application, but the transmission fluid temperature gauge reading should not exceed 250°F (121°C).

---

### NOTICE

---

**A sudden increase in transmission fluid temperature that is not caused by a load increase may indicate mechanical failure. Bring the vehicle to a safe stop and investigate the cause to prevent further damage. Do not operate the vehicle until the cause has been determined and corrected.**

Under heavy loads, such as when climbing steep grades, temperatures that exceed the normal oil temperature range for a short period are not unusual. If the temperature returns to normal when the load decreases, there is no problem.

## Turbocharger Boost Pressure Gauge

The turbocharger boost pressure gauge measures the pressure in the intake manifold being created by the turbocharger, in excess of atmospheric pressure.

## Driver Message Center

### ICU4

#### Functions

The mode/reset button, located on the right side of the lightbar, controls the driver message center. Press the mode/reset button to advance one screen; hold the button down to select a menu choice or reset the display. When the display is reset, an audible chirp sounds.

#### Direct Access Screens

When the parking brake is not set, pressing the mode/reset button will scroll through the direct access screens.

- i. Trip distance
- ii. Trip hours
- iii. Outside temperature
- iv. Back to odometer
- v. Select screen
- vi. Temperature alert screen
- vii. Diagnostic screen
- viii. Clear screen (with less than 254 miles)
- ix. Engine miles
- x. Engine hours
- xi. Setup screen

## Stationary Access Screens

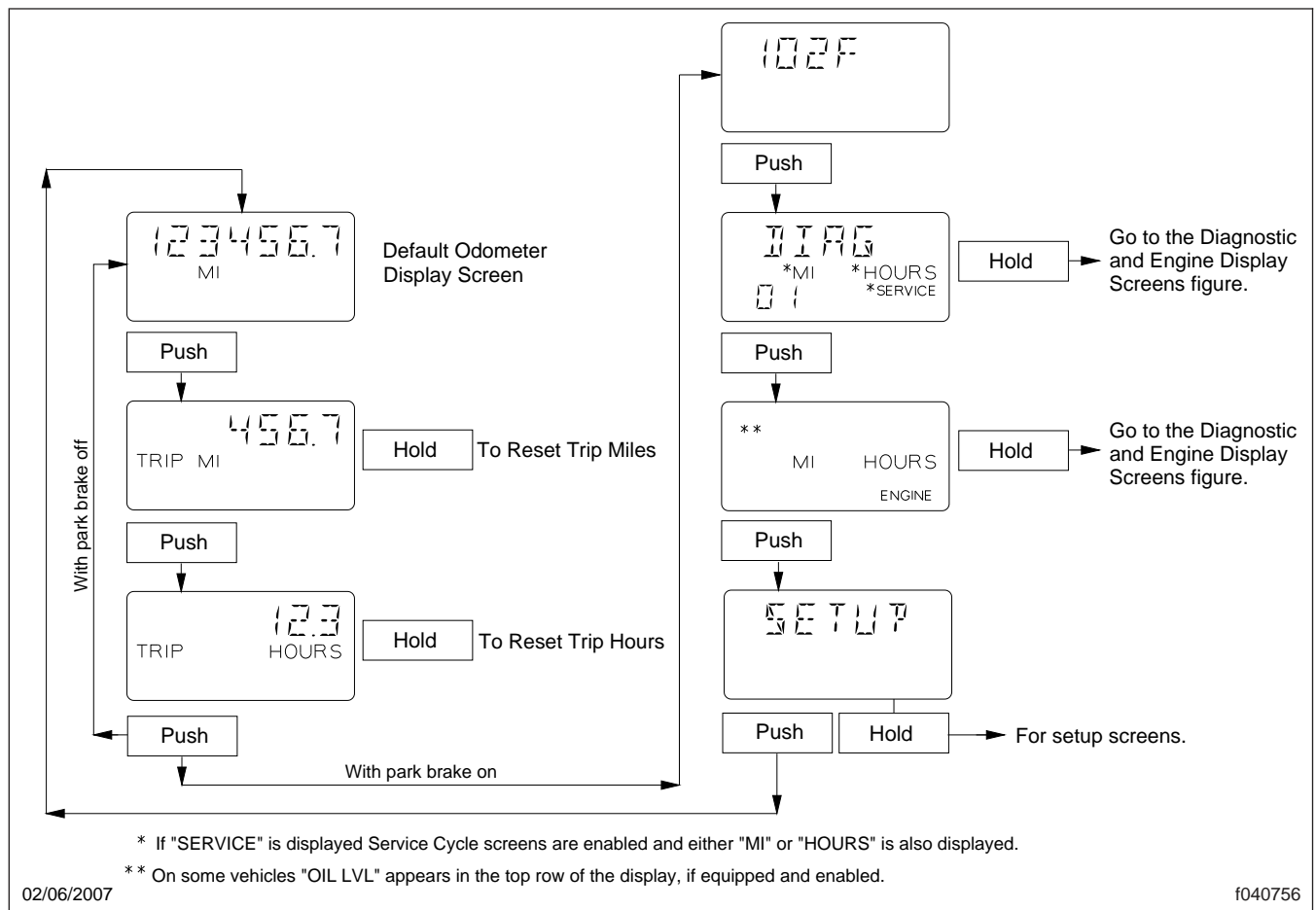
When the parking brake is set, pressing the mode/reset button will scroll through the stationary access screens. See [Fig. 4.7](#).

- i. Odometer
- ii. Trip distance
- iii. Trip hours
- iv. Outside temperature

## Trip Information

Trip information allows you to view trip mileage and time.

When the odometer reading is displayed, press the mode/reset button once for trip distance. Press the



**Fig. 4.7, ICU4 Stationary Access Screens**

# Instruments

---

mode/reset button a second time for trip hours (engine hours).

Press and hold the mode/reset button to reset trip miles or hours to zero.

## Ambient Air Temperature

When the ambient air temperature drops below 35°F (1.7°C), the ICU displays a caution text at 1-second intervals for five seconds and a chime sounds if the ambient temperature alarm is enabled. The driver can acknowledge the message by pressing the mode/reset button. The chime will not sound again unless the temperature cycles above 37°F (4°C) and back below 35°F (1.7°C).

When the parking brake is set, the ambient air temperature display can be changed from °F to °C by changing the MI or KM selection in the SETUP menus. The warning message can be disabled or enabled in the SETUP menus.

## Diagnostic Screens

The diagnostic screens are used by trained technicians to retrieve fault codes and other diagnostic information pertaining to the vehicle. Active faults are current problems that require attention. If active fault codes display during start-up or at any other time, make a note of the fault code and text message, then call an authorized Freightliner service facility for assistance.

During vehicle start-up, with the parking brake set, the ICU4 will display any active fault codes for three seconds each until the parking brake is released. If service cycle screens are enabled and service distance or time has been exceeded, the text SERVICE HOUR/MI (KM) will be displayed to inform the driver that the service interval has been exceeded and vehicle service is required. See [Fig. 4.8](#) for the diagnostic and engine display screens.

To access the diagnostic screens, press and hold the mode/reset button when the DIAG screen is displayed.

If the word SERVICE appears on the diagnostic message display screen, service cycle screens are enabled. Either service miles or hours can be enabled, but not both. Hold the mode/reset button to display miles or hours remaining until the next scheduled service. If MI (KM) appears on the DIAG screen, service miles are enabled; if HOURS appears on the

screen, service hours are enabled. If service miles or hours have been exceeded, the number flashes to indicate service is overdue.

## Engine Screens

The engine screen displays total engine miles or hours. Press and hold the mode/reset button to display total engine miles. Press and hold it a second time to display total engine hours.

To access the engine screens, press and hold the mode/reset button when the engine miles/hours screen is displayed.

## Setup Screens

The setup screens are used to manage ICU4 parameters. See [Fig. 4.9](#).

To access the setup screens, press and hold the mode/reset button when the SETUP screen is displayed.

For each parameter, press and hold the mode/reset button to navigate to the parameter change screen. In each change screen, use the mode/reset button to toggle between options.

The last screen in the setup menu, **RESET EE**, is for resetting certain parameters to the original settings. Hold the mode/reset button to reset the antilock braking system (ABS), SAMS roll call, automated transmission display, transmission heartbeat, sensor fault codes, and engine oil level screens. Press the mode/reset button to sequence back to the odometer.

## ICU4M

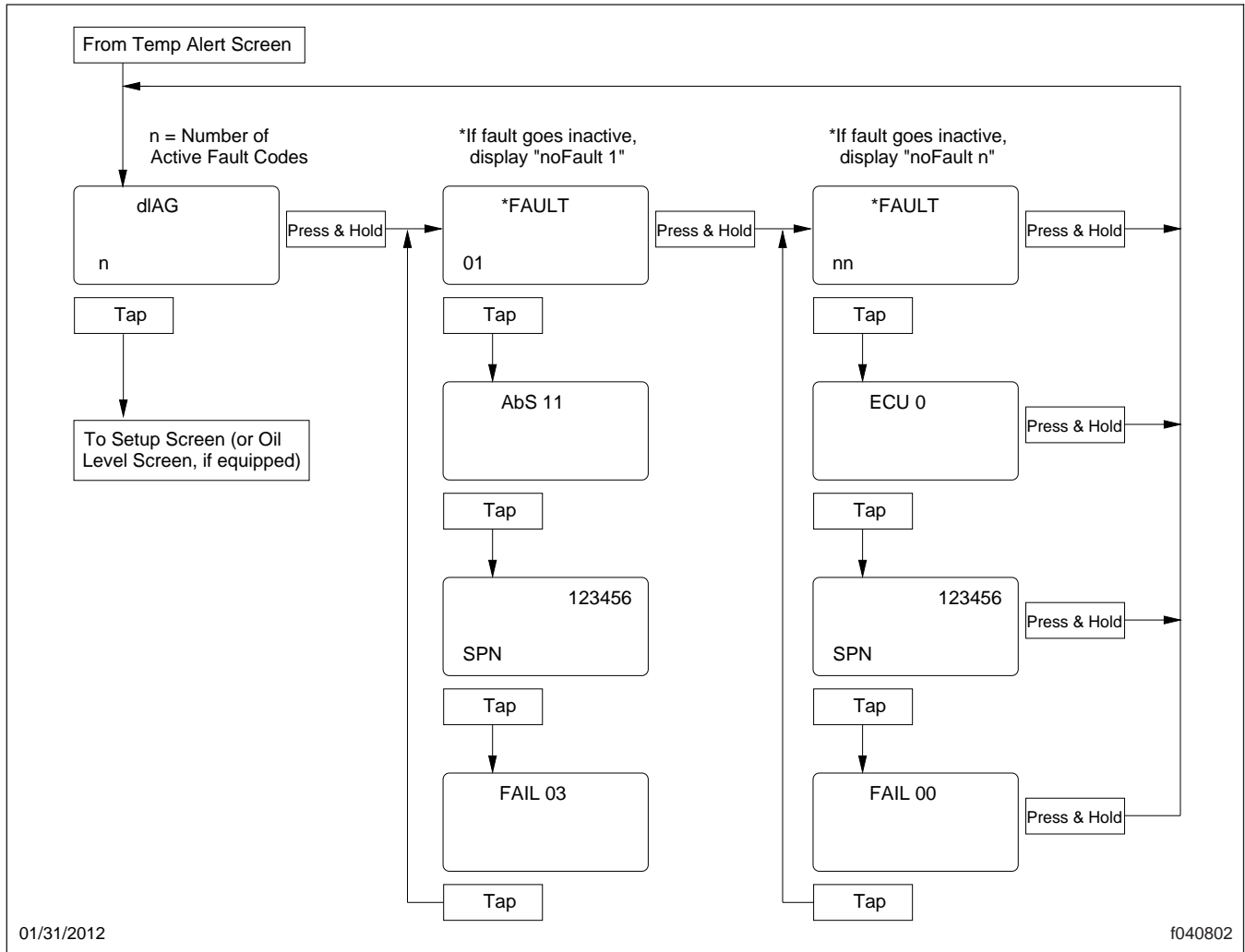
### Functions

ICU4M settings and the driver message center are controlled with the +/- INFO switch and the MY INFO switch, mounted on the dash. See [Fig. 4.10](#). Press the upper half of the +/- INFO switch to scroll up; press the lower half of the +/- INFO switch to scroll down. Press and hold the upper half of the +/- INFO switch to reset or select a menu choice. When the display is reset, an audible chirp sounds.

Some main features of the ICU4M include:

- Gauges that sweep 270 degrees and have pointers lit by an LED.
- Service intervals that are programmable via two dash-mounted switches.





**Fig. 4.8, ICU4 Diagnostic and Engine Display Screens**

- A warning chime and alert message to warn the driver if the door is opened without first setting the parking brake.
- A flashing alert message that appears on the driver message center in low engine oil pressure or high coolant temperature conditions.

With the parking brake released, only the odometer and alert screens can be displayed. Park the vehicle and set the parking brake to display additional screens.

The dash message center displays alert screens when certain conditions occur. They are warnings, cautions, or other messages that require the driver's

attention, but not all of them are critical to the operation of the vehicle. Warning messages always display at full brightness.

More important messages take priority over less important messages. The order of priority, is:

1. parking brake set (with the vehicle moving)
2. parking brake off (with door open)
3. low oil pressure or high coolant temperature
4. hard brake warnings (if equipped with roll stability advisor)
5. low battery voltage

# Instruments

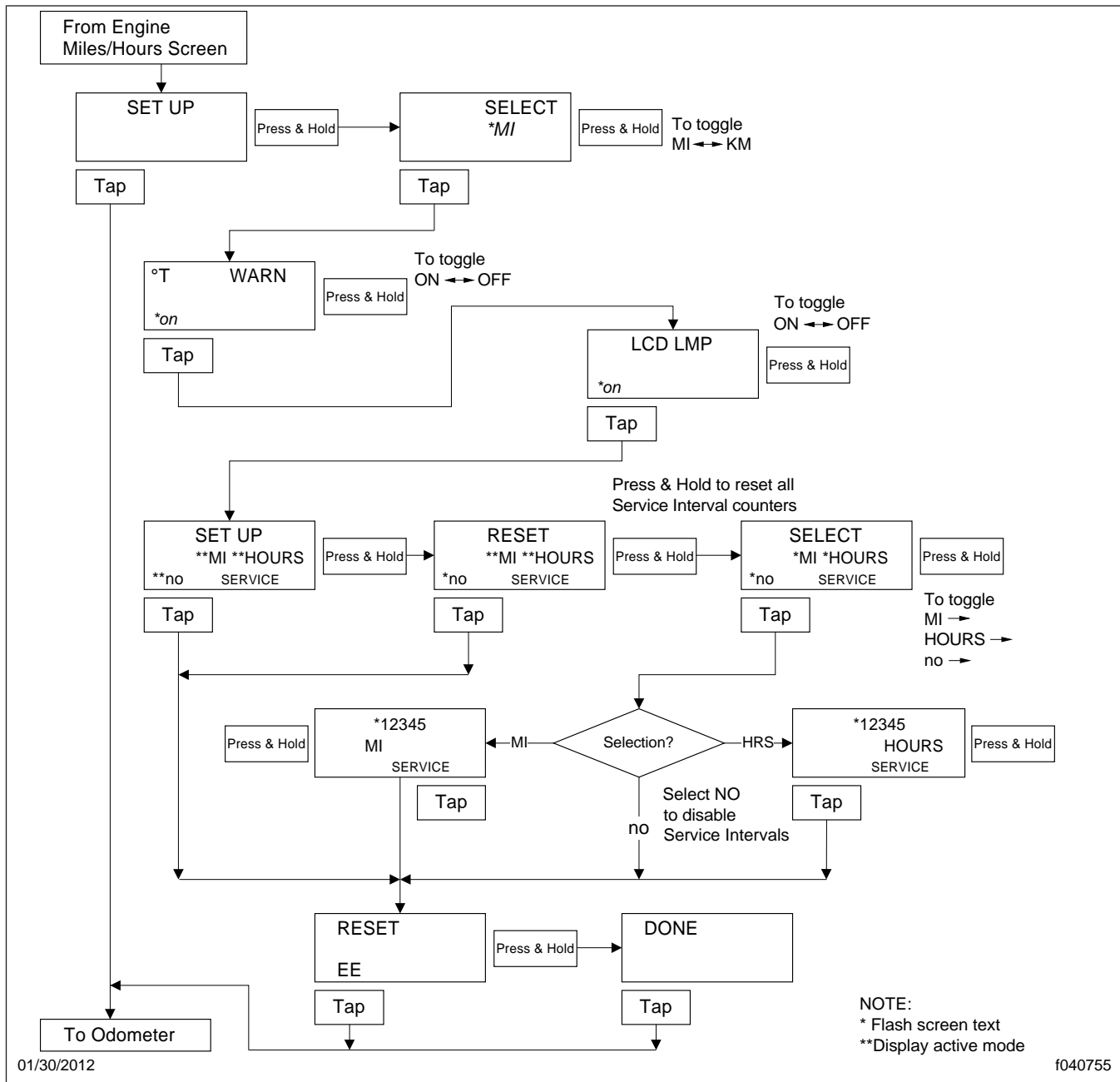


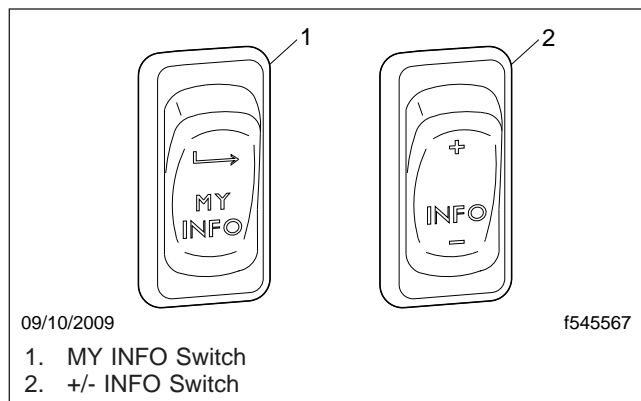
Fig. 4.9, ICU4 Setup Screens

6. ambient temperature below 35°F (1.7°C)
7. turn signal on
8. incoming instant or Qualcomm messages
9. service warnings

10. no datalink activity

## Alert Screens

NOTE: If there is more than one alert message to display, pressing the +/- INFO switch or the



**Fig. 4.10, ICU4M Info Switches**

MY INFO switch takes you to the next message, and so on, until all the messages have been received.

## INCOMING MESSAGE

On vehicles with a Qualcomm onboard communications system, this message appears on the message display screen whenever a message is received.

**NOTE:** The incoming message screen also displays during the ignition sequence if a message is available.

This message displays for a preset time period and then disappears. It returns after a preset interval until it is dismissed by pressing the +/- INFO switch or the MY INFO switch.

## PARK BRAKE ON

This warning message and an audible warning come on whenever the parking brake is applied and the vehicle is moving faster than two miles per hour. See [Fig. 4.11](#). The screen and audible warning go away only when the parking brake is released, or speed is reduced below 2 mph (3 km/h).



**Fig. 4.11, Park Brake On Alert Screen**

## LOW OIL PRESSURE

This warning message and an audible warning come on whenever the oil pressure falls below the minimum oil pressure, whether the vehicle is idling or in motion. Dismiss the message by pressing the +/- INFO switch or the MY INFO switch.

If low oil pressure is detected during the ignition sequence, it displays as an active fault and the alert screen does not appear.

After 30 seconds, this message displays again and can be dismissed as before by pressing the +/- INFO switch or the MY INFO switch.

## HIGH COOLANT TEMP

This message and an audible warning come on whenever the engine coolant temperature exceeds the maximum allowable temperature.

If high coolant temperature is detected during the ignition sequence, it displays as an active fault and the alert screen does not appear.

After 30 seconds, this message displays again and can be dismissed as before by pressing the +/- INFO switch or the MY INFO switch.

## LOW VOLTAGE

On some vehicles, this optional message and an audible warning come on whenever a low voltage condition is detected by the ICU

## TURN SIGNAL ON

This warning message and audible warning come on whenever the turn signal remains on for four minutes or five miles of travel.

To dismiss this message, either turn off the turn signal or press the +/- INFO switch or the MY INFO switch.

## AIR TEMPERATURE

When the outside ambient air temperature drops below 35°F (1.7°C), the ICU will display a warning text at 1-second intervals for five seconds, and an audible warning will sound. The driver must acknowledge the warning by pressing the +/- INFO switch or the MY INFO switch. The alert message will not occur again unless the temperature cycles above 37°F (4°C) and back below 35°F (1.7°C). This warning only occurs while the ignition is on and the parking brake off. The outside ambient air temperature

# Instruments

---

will display in degrees Fahrenheit if MI is selected in the setup screens, or degrees Celsius if KM is selected.

## Service Warnings

Service warning screens display during the ignition sequence and indicate that a service interval has been reached or exceeded and maintenance is required. The messages may indicate the number of miles (KM) or hours until the next required service or, once passed, the number of miles (KM) or hours ago that maintenance should have been performed.

## Automated Transmission Display

The ICU4M can display current gear information for vehicles with an automated transmission. The last three digits at the far right on the lower line of the driver display screen are reserved for this information.

If there is a request to shift, an up or down arrow is also displayed, depending on the shift direction.

On vehicles with conventional manual or automatic transmissions, the gear and shift direction are not displayed. For more information about specific models of automated transmissions, see [Chapter 14](#).

## Direct Access Screens

When the parking brake is not set, pressing the mode/reset button or the +/- INFO switch will scroll through the direct access screens. See [Fig. 4.12](#).

- Fasten seat belt (rpm<100)
- Fuel economy (rpm>100)
- Trip distance/hours
- Trip advisory
- Leg distance/hours
- Leg advisory
- Fuel used/average MPG (KM/L)
- Outside air temperature

## Favorite Screen

The driver can access a preset favorite direct access screen using the MY INFO switch. Holding down the lower half of the MY INFO switch for just over one second will set the current screen as the favorite screen. A chirp will sound to verify the screen has

been set. Only direct access screens can be selected as the favorite screen.

The favorite screen can be called up by pressing the lower half of the MY INFO switch. The favorite screen can be accessed with the parking brake off or on. There is no time-out for this screen. The screen can be acknowledged by pressing the +/- INFO switch.

## Stationary Access Screens

When the parking brake is set, pressing the mode/reset button or the +/- INFO switch will scroll through the stationary access screens.

- Trip information including trip miles/hours, idle hours, average speed, leg miles/hours
- Fuel information including fuel used, fuel economy, idle/PTO fuel usage
- Engine information including engine miles/hours, engine/PTO gallons, oil level
- Diagnostic information
- Service information including mileage or time to next service
- Setup information
- Vehicle information including Datalink status, ICU serial number, software version
- Fasten seat belt warning (rpm <100)
- Idle hours rpm >100)
- Outside air temperature

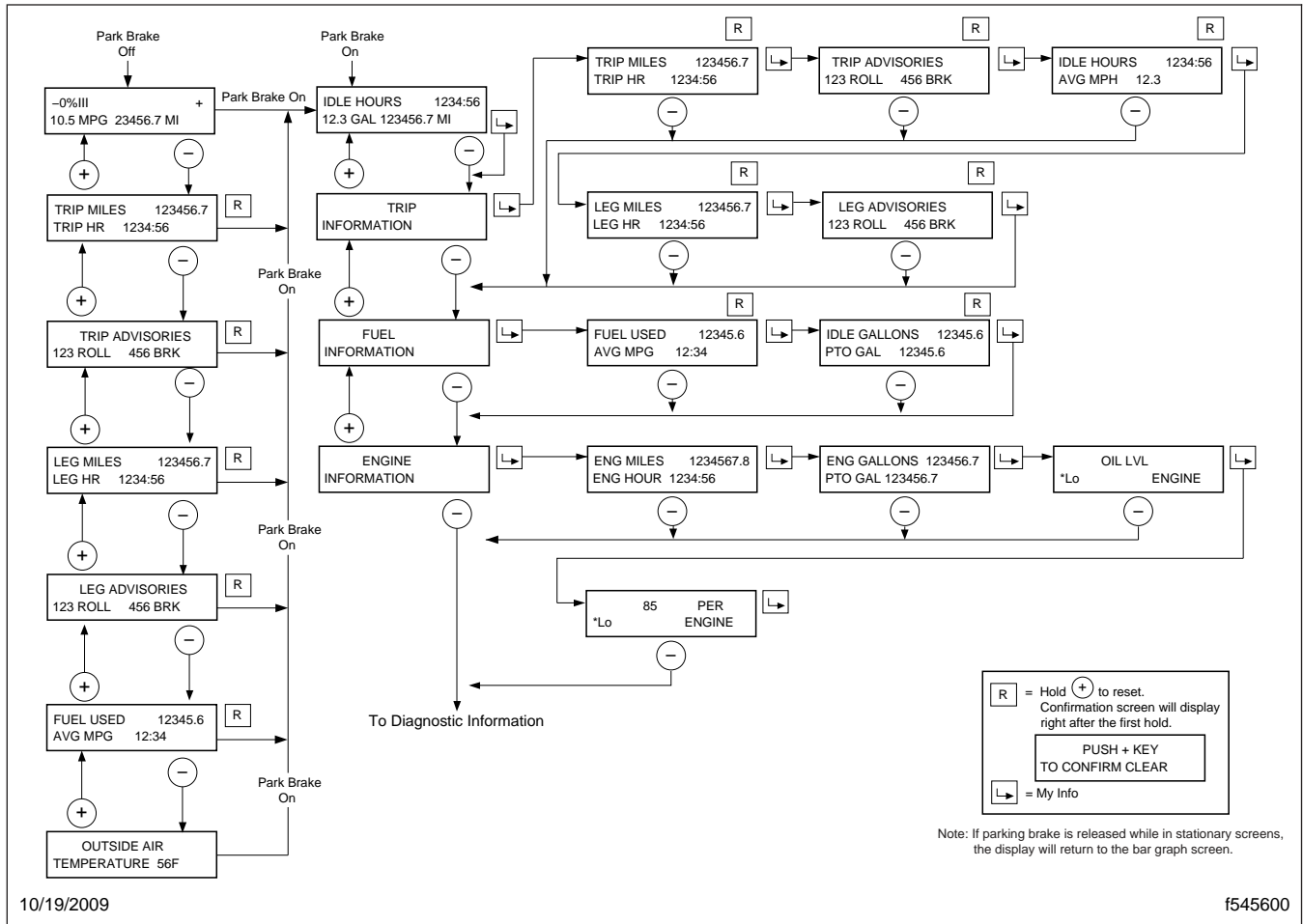
Use the +/- INFO switch to scroll through the menus and press the MY INFO switch to advance to the sub-menus. Hold the upper half of the +/- INFO switch to reset the counters for trip and fuel information.

## Vehicle Information Screens

The vehicle information screens display hardware and software information, including the Freightliner part number and switch ID of the ICU. See [Fig. 4.13](#).

## Trip Information

When idle hours is displayed, press the +/- INFO switch or the MY INFO switch to display the main trip information screen. See [Fig. 4.14](#).



**Fig. 4.12, ICU4M Stationary and Direct Access Screens**

Press the MY INFO switch to advance to trip miles, trip advisories, idle hours, leg miles, and leg advisories, in that order. Press and hold the upper half of the +/- INFO switch to reset any of the screens.

## Fuel Information

Fuel information allows you to view total fuel usage since the last reset, fuel mileage, and fuel consumed while idling or running the PTO. Press the MY INFO switch to advance through the fuel information screens. Press and hold the upper half of the +/- INFO switch to reset any of the screens.

## Engine Information

Engine information allows you to view engine mileage and hours, and total fuel consumption. Press the

MY INFO switch to advance through the engine information screens.

## Diagnostic Information

If active fault codes are displayed on the diagnostic information screens, make a note of the fault code and text message, then call an authorized Freightliner service facility for assistance. See [Fig. 4.15](#) for a diagram of the diagnostic information screens.

## Service Information

Service information allows you to view the next recurring service interval, expressed in either miles or hours. Service intervals can also be deactivated, so they do not display at all. For programming service intervals, see the heading below, **Setup Information**.

# Instruments

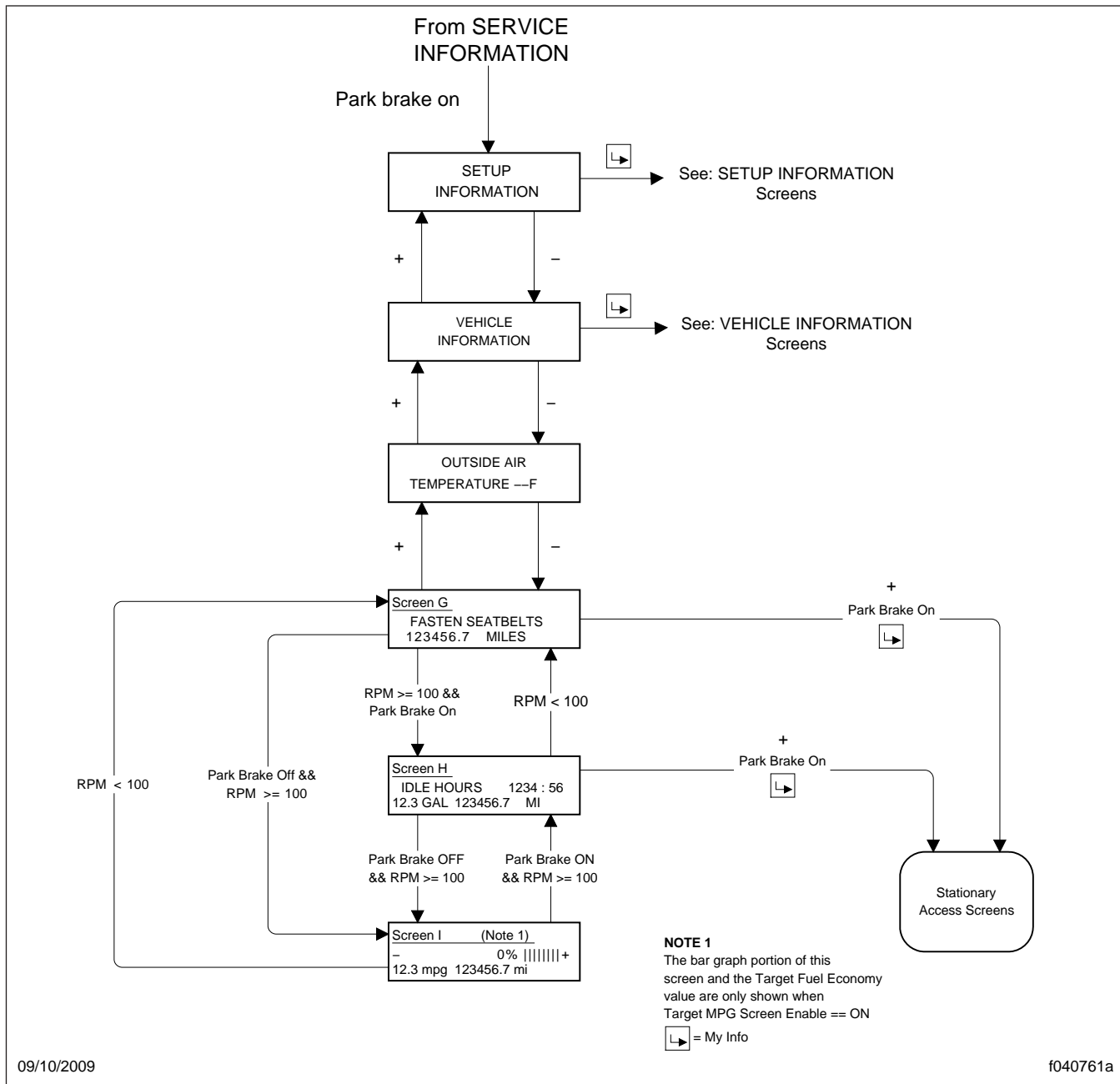


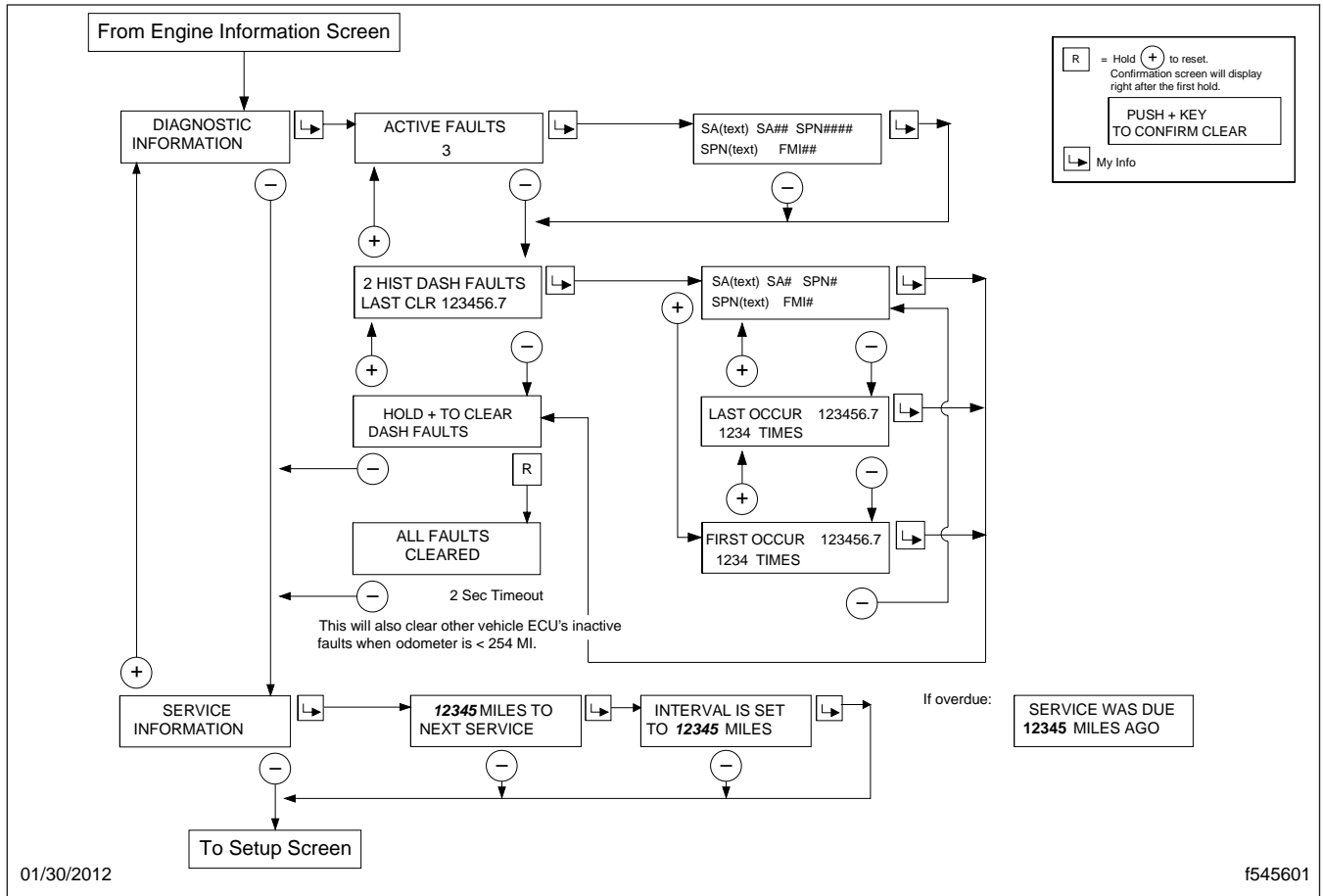
Fig. 4.14, ICU4M, Standard Screens

NOTE: If the vehicle has gone past the service interval, the **miles(km)/hours remaining** screen is replaced by the **service was due** screen, followed by the number of miles(km)/hours since the service was due.

## Setup Information

See [Fig. 4.16](#) for a diagram of the setup information screens.

Setup information allows you to program various features of the ICU4M environment, including:



**Fig. 4.15, ICU4M Diagnostic and Service Information Screens**

1. Service intervals (OFF/MILES/HOURS);
2. Ambient Temperature Warning (ON/OFF);
3. Target MPG;
4. LCD Lamp (ON/OFF);
5. Driver message display brightness;
6. Language (English, French, Spanish);
7. Units of measurement (English/Metric);
8. Reset parameters to original settings.

Use the steps below to navigate the setup information screens. On each change screen, press and hold the upper half of the +/- INFO switch to increase the setting. Press and hold the lower half of the +/- INFO switch to decrease the setting. Release the

button at the desired setting, then press it briefly to select.

1. Press the MY INFO switch to advance to the service interval screen. Press and hold the upper half of the +/- INFO switch to toggle between **OFF**, **MILES**, and **HOURS**. Release the upper half of the +/- INFO switch at the desired choice, then press it again briefly to select the choice.

If you select **OFF** at the selection screen (meaning you have turned off service interval information), the screen will skip the remaining service screens.

2. Press the MY INFO switch to go to the change screen. Hold the upper half of the +/- INFO switch to scroll through the intervals, then release and briefly press the upper half of the +/- INFO switch again to select the desired interval.

# Instruments

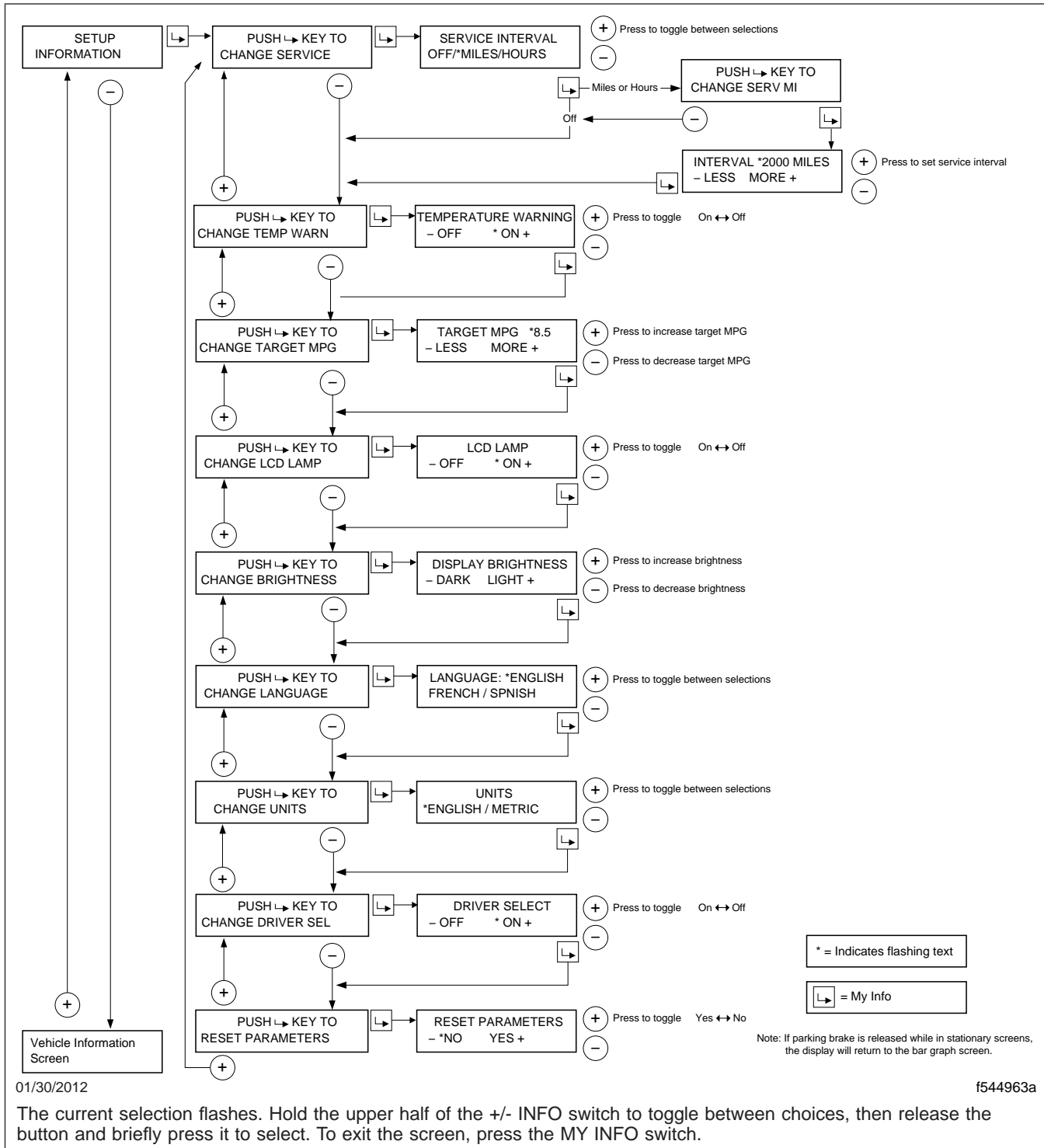


Fig. 4.16, ICU4M Setup Information Screens



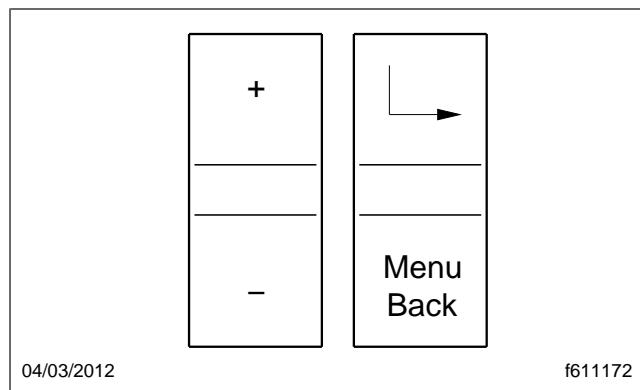
3. Press the MY INFO switch to advance to the **TEMPERATURE WARNING** screen. Press the MY INFO switch to go to the change screen. Press the upper half of the +/- INFO switch to toggle between **ON** and **OFF**.
4. Press the MY INFO switch to advance to the **CHANGE TARGET MPG** screen. Press the MY INFO switch to go to the change screen.
5. Press the MY INFO switch to advance to the **CHANGE LCD LAMP** screen. Press the MY INFO switch to go to the change screen. Press the upper half of the +/- INFO switch to toggle between **ON** and **OFF**.
6. Press the MY INFO switch to advance to the **CHANGE BRIGHTNESS** screen. Press the MY INFO switch to go to the change screen.
7. Press the upper or lower half of the +/- INFO switch to select the desired brightness setting.
8. Press the MY INFO switch to advance to the **CHANGE LANGUAGE** screen. Press the MY INFO switch to go to the change screen.
9. Press the upper or lower half of the +/- INFO switch to select the desired language.
10. Press the MY INFO switch to advance to the **CHANGE UNITS** screen. Press the MY INFO switch to go to the change screen.
11. Press the upper or lower half of the +/- INFO switch to toggle between English and metric.
12. Press the MY INFO switch to advance to the **RESET PARAMETERS** screen.
  - 12.1 Press the MY INFO switch to go to the change screen.
  - 12.2 Press the upper half of the +/- INFO switch to toggle between **YES** and **NO**.
13. Press the MY INFO switch to return to the beginning of the setup menus.

## ICU4Me

### Functions

ICU4Me settings and the driver message center are controlled using the ICU4Me control switch located on the dash. See [Fig. 4.17](#).

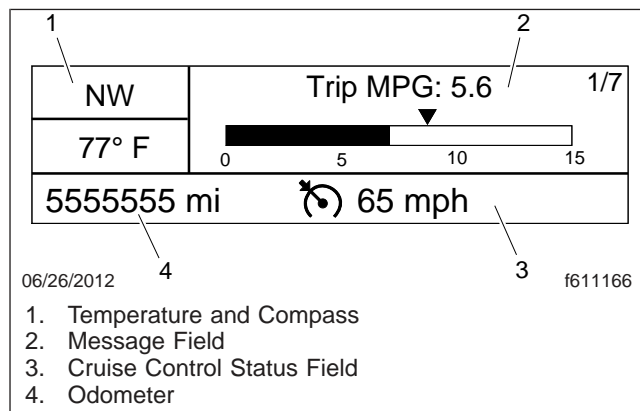
The driver message center is divided into four sections. The odometer and cruise control status field



**Fig. 4.17, ICU4Me Control Switch**

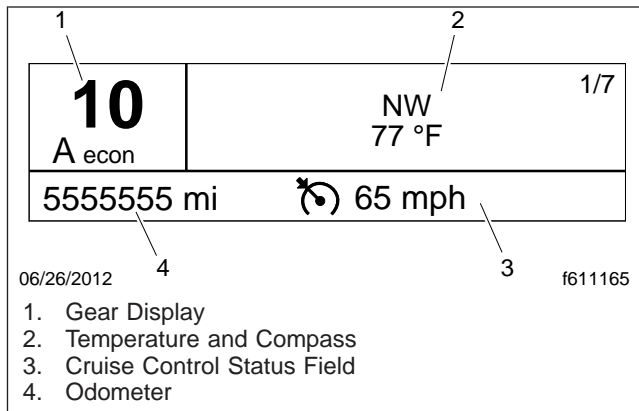
are displayed along the bottom of the message center. When cruise control is active, the cruise control status field displays relevant cruise control icons and the set speed. If the vehicle is equipped with a manual transmission, time and temperature are displayed in the top left corner of the driver message center. The message field displays the driving screens and alert messages. See [Fig. 4.18](#).

If the vehicle is equipped with an automated transmission, the gear display is located in the top left corner of the driver message center. Time and temperature are displayed in the message field, unless an alert message is active or a driving screen has been selected. The odometer and cruise control status fields are displayed along the bottom of the message center. See [Fig. 4.19](#). For information about transmission display options, see [Chapter 14](#).



**Fig. 4.18, Driver Message Center Without Gear Display, ICU4Me**

# Instruments

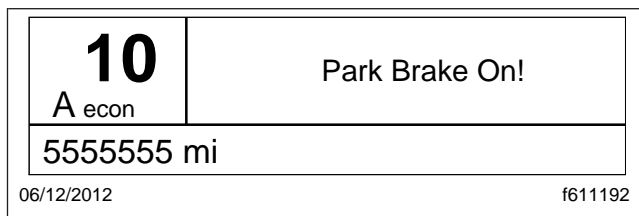


**Fig. 4.19, Driver Message Center with Gear Display, ICU4Me**

## Alert Messages

Alert messages are displayed in the message field to notify the driver when certain conditions occur. They include warnings, cautions, and other messages that require the driver's attention. Not all alert messages are critical to the operation of the vehicle. More important messages take priority over less important messages.

NOTE: All alert messages follow the format shown in [Fig. 4.20](#).



**Fig. 4.20, Parking Brake Alert Message**

Press the + switch to acknowledge alert messages and revert to the previously displayed driving screen. The following alert messages will repeat intermittently until the condition is eliminated:

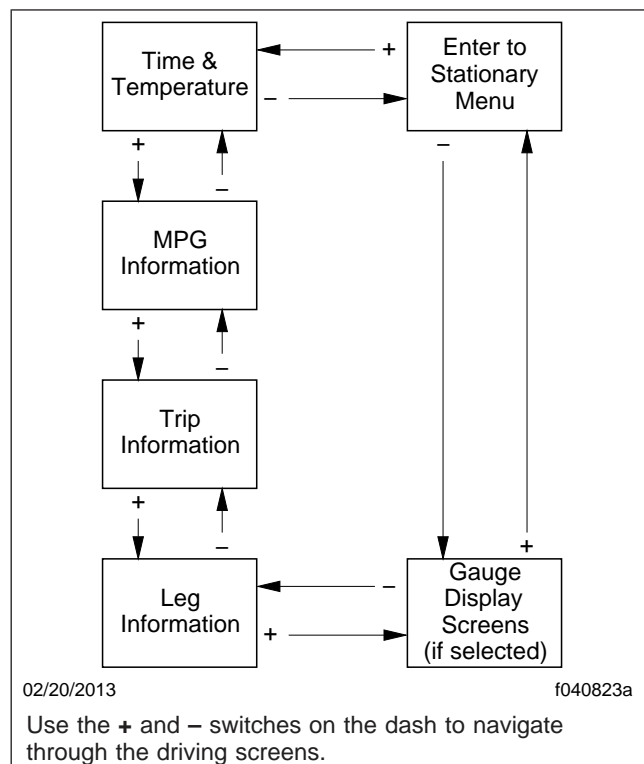
- turn signal on
- low voltage
- no datalink

## Driving Screens

With the parking brake off, only the driving screens are available. Use the + and - switches on the steering

wheel to scroll through the driving screens; see [Fig. 4.21](#). To reset any values, press and hold the + switch.

- Temperature
- MPG information
- Trip information
- Leg information
- Gauge display (if selected)
- Enter parked menus



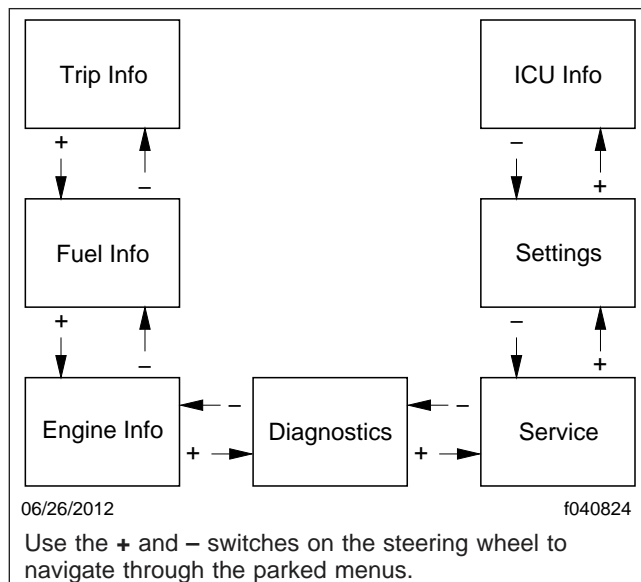
**Fig. 4.21, Driving Screen Navigation, ICU4Me**

## Parked Screens/Menus

Park the vehicle and set the parking brake to access the parked menus and submenus. See [Fig. 4.22](#). To reset values in any of the menus, press and hold the + switch.

- Trip information
- Fuel information
- Engine information

- Diagnostics
- Service information
- Settings
- ICU Information



**Fig. 4.22, Parked Menus, ICU4Me**

A small numerical fraction is displayed in the upper right-hand corner of each screen to indicate the number of available screens or options to scroll through. See Fig. 4.23. Press the upper half of the ICU4Me control switch to select a menu choice. Press the lower half of the control switch to back out of a selected menu or submenu. Use the + switch to scroll up, and the - switch to scroll down.

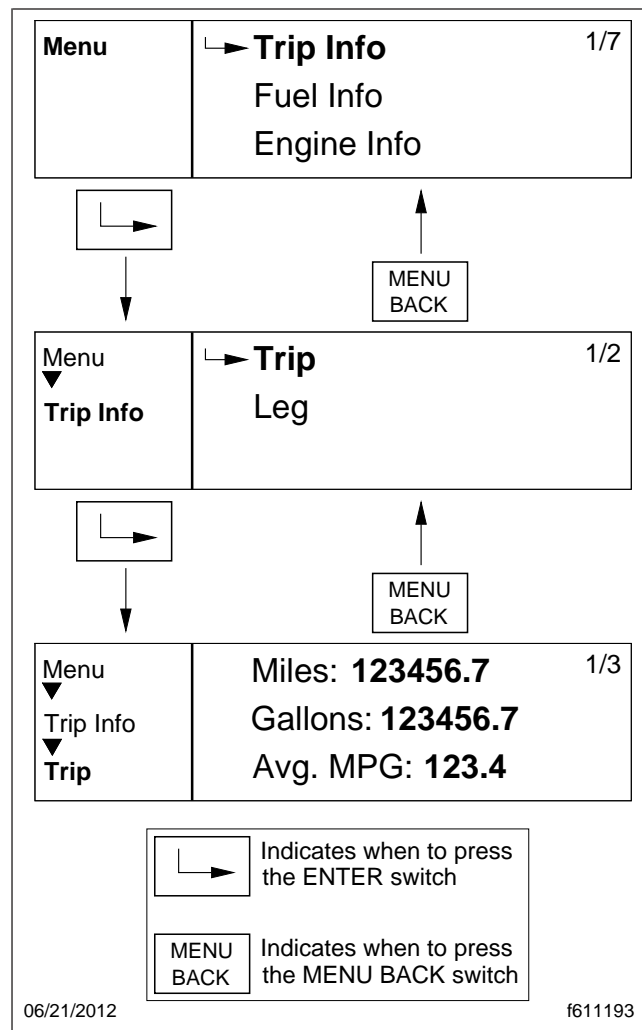
When navigating the parked menus, the left side of the driver message center displays a "breadcrumb menu" to show the order of menus and submenus that have been selected during the current navigation.

## Trip Information

The ICU can record data for one trip segment and one leg segment. When trip information is reset, all the leg information is reset as well.

## Fuel Information

Using this menu, the driver can view the total fuel used since the last reset, the total idle gallons used



**Fig. 4.23, Parked Menu Navigation, ICU4Me**

since the last reset, and the average MPG since the last reset.

## Engine Information

Using this menu, the driver can view engine miles, engine hours, gallons used, PTO hours, and PTO gallons. Engine oil level is optional for Detroit engines. The information contained in the Engine Information screens cannot be reset.

## Diagnostics

Active and historical faults are displayed in the diagnostics menu. See Fig. 4.24. If there are any active

# Instruments

faults, the total number of faults is displayed in parenthesis next to the affected controller. To view specific active faults, press the upper half of the ICU4Me control switch on the dash. Press the upper half of the ICU4Me control switch to toggle between the text description and the failure code for each selected fault.

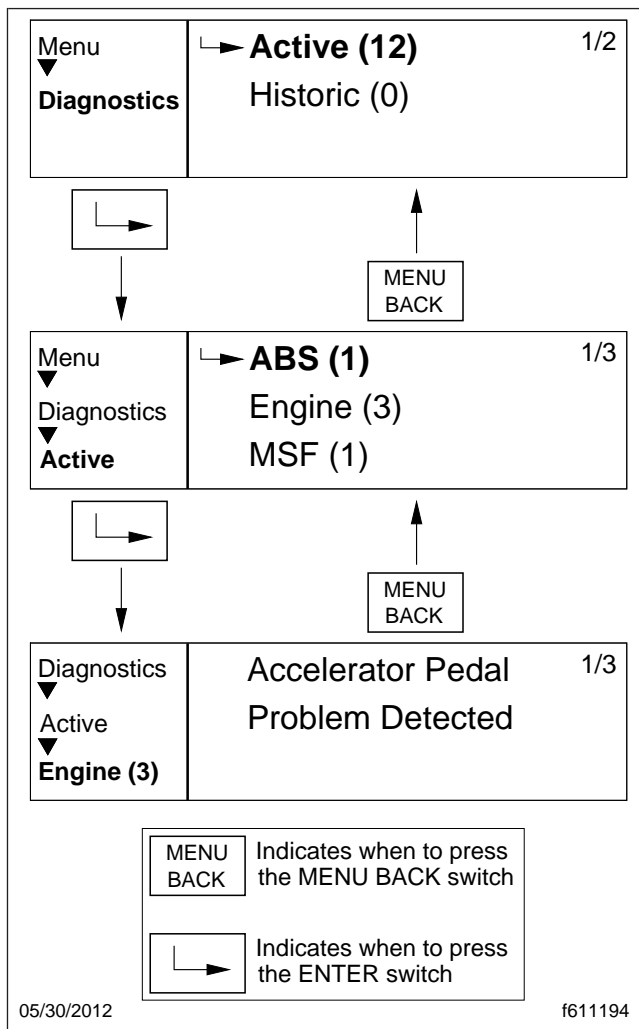


Fig. 4.24, Diagnostics Menu Navigation, ICU4Me

## Service Information

Using this menu, the driver can enable, disable, and set service intervals for engine miles or engine hours. After enabling service intervals, select interval unit (miles or hours), and the interval duration.

## Settings

The settings menu contains the controls for the following settings:

- Display (includes brightness, contrast, display light, and night mode settings)
- Gauge select
- Language
- Temperature warning enable/disable
- Units

The Gauge Select submenu allows the driver to select certain gauge values for display in the message field while driving. See Fig. 4.25. Use the + and - switches on the dash to scroll through the list of available gauges, then press the upper half of the ICU4Me control switch to select a desired gauge. The ICU4Me control switch can also be used to uncheck boxes if necessary.

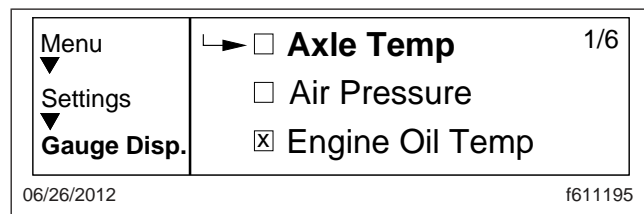


Fig. 4.25, Selecting Gauges to Display, ICU4Me

## ICU Information

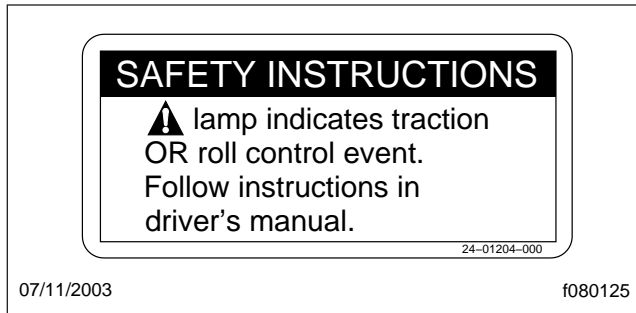
The ICU Information screen displays the part numbers for the instrument cluster and software.

## Roll Stability System

The roll stability system may entail Roll Stability Advisor (RSA) only, or it may also include Roll Stability Control (RSC).

A decal (Fig. 4.26) on the auxiliary dash panel and an amber-colored dash indicator light (Fig. 4.27), indicate that the vehicle is equipped with roll stability system components.

**NOTE:** The roll stability system indicator is located on the lightbar in place of the WHEEL SPIN indicator.



**Fig. 4.26, Roll Stability Decal**



**Fig. 4.27, Roll Stability Indicator Lamp**

## Roll Stability Advisor

**IMPORTANT:** This is not an advance warning system. The RSA displays a message only after the driving maneuver is completed.

The roll stability system uses a lateral-acceleration sensor that monitors rollover risk. Shortly after a curve, lane change, or other driving maneuver that results in a rollover risk detection, a dash warning light illuminates, an audible tone sounds, and an advisory message is displayed in the driver message center. The purpose is to advise the driver that the previous maneuver produced a rollover risk.

The RSA displays different text messages depending on the severity of the risk of each rollover risk occurrence. From the highest risk level to the lowest risk level, the system will sound a warning tone and display a message, as shown in [Fig. 4.28](#).

**NOTE:** The system will calculate and recommend a speed reduction value. It may be different than the values shown here.

Bring the vehicle to an authorized Freightliner service facility if a system failure message is displayed.

| MSG No. | Message      | Message to Display  | Display Time: Seconds | Buzzer Time: Seconds |
|---------|--------------|---|-----------------------|----------------------|
| 1       | System Fault | WARNING<br>RAC SYSTEM FAIL  | 4                     | 1                    |
| 2       | RSC          | ACTIVE SLOWING<br>ROLLOVER RISK   | 4                     | None                 |
| 3       | RSA Level 3  | VERY HIGH RISK OF +<br>ROLLOVER DETECTED<br>REDUCE SPEED +<br>AT LEAST 7 MPH<br>or in metric<br>REDUCE SPEED +<br>AT LEAST 11 KPH | 19.6                  | 10                   |
| 4       | RSA Level 2  | HIGH RISK OF +<br>ROLLOVER DETECTED<br>REDUCE SPEED +<br>AT LEAST 7 MPH<br>or in metric<br>REDUCE SPEED +<br>AT LEAST 11 KPH      | 14                    | 5                    |
| 5       | RSA Level 1  | ROLLOVER RISK +<br>DETECTED<br>REDUCE SPEED +<br>AT LEAST 7 MPH<br>or in metric<br>REDUCE SPEED +<br>AT LEAST 11 KPH              | 8.4                   | 2                    |
| 6       | HBED Level 3 | HARD BRAKING WITH +<br>ABS ACTIVATED<br>LOOK AHEAD +<br>BRAKE SOONER  | 14                    | 0.5                  |
| 7       | HBED Level 2 | HARD BRAKING +<br>DETECTED<br>LOOK AHEAD +<br>BRAKE SOONER  | 14                    | 0.5                  |
| 8       | HBED Level 1 | LOSS OF TRACTION +<br>ABS ACTIVATED<br>ROAD SURFACE +<br>MAY BE POOR  | 14                    | 0.5                  |

**Fig. 4.28, Roll Stability and Hard-Braking Warnings**

# Instruments

## Roll Stability Control



The Roll Stability Control system is intended only as an aid for a conscientious and alert driver. Carefully read the information in this manual to understand this system and its limitations. The Roll Stability Control system is not a substitute for safe driving procedures. Failure to drive safely, and use the system properly, could result in personal injury and/or death and property damage.

The RSC system automatically reduces engine power, applies the engine brake, and/or applies the tractor and trailer brakes when the sensor detects that the vehicle is at risk of rolling over. RSC can intervene even before an advisory message is displayed.

The dash indicator light illuminates whenever the RSC system intervenes.

## Hard-Braking Advisor

The hard braking advisor uses the information from the ABS wheel speed sensors to determine when braking is severe enough to produce lockup at one or more wheels on the tractor, and/or very rapid vehicle deceleration. Shortly after a hard braking event occurs, an advisory message is displayed in the driver message center, indicating that the braking behavior was too aggressive for the current road surface conditions. This system is not a replacement for a driver's good judgment.

From the highest risk level to the lowest risk level, the system will sound a warning tone and display a message, as shown in [Fig. 4.28](#).

## Trip/Leg Totals

The driver message center records the number of messages received and displays the number of messages as counts. RSA and hard braking event data (HBED) counts can be viewed in the trip advisory screen and the leg advisory screen. The trip and leg advisor screens count both the roll stability advisories (ROLL) and hard braking events (BRK). For example, if during a trip, the driver message center recorded the events in [Table 4.5](#), the message center would display as shown in [Fig. 4.29](#).

| RSA/HBED Count   |                |
|------------------|----------------|
| Message Received | Message Counts |
| RSA Level 3      | 2              |
| RSA Level 2      | 3              |
| RSA Level 1      | 7              |
| HBED Level 3     | 5              |
| HBED Level 2     | 1              |
| HBED Level 1     | 8              |

Table 4.5, RSA/HBED Count

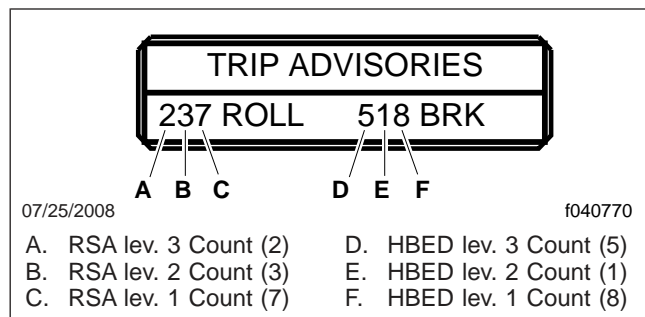


Fig. 4.29, Trip Advisor Message Screen

If the count reaches more than 9 occurrences an up arrow will appear to indicate to the driver that the count has exceeded 9 counts. See [Fig. 4.30](#).

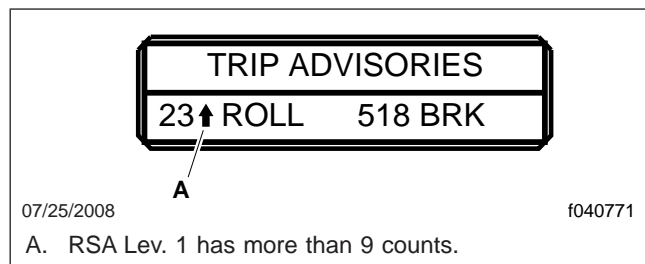


Fig. 4.30, Trip Advisor Message Screen (more than 9 counts)

## Overhead Instrument Panel

The optional overhead instrument panel may hold a citizen's band (C/B) radio and any switches that can not be accommodated on the driver's or auxiliary dash panels.

The underside of the overhead console also holds the sun visors and the optional dome/reading light assembly. For more information on the dome/reading light assembly, see [Chapter 7](#).

# 5

## Driver Controls

---

|   |     |
|---|-----|
| Steering Column and Left-Hand Dash Controls ..... | 5.1 |
| Door Mounted Controls .....                       | 5.2 |
| Lower Right-Hand Dash Panel Switches .....        | 5.3 |
| Main Dash Switches .....                          | 5.4 |
| Windshield Wiper/Washer .....                     | 5.6 |
| Guarded Switches .....                            | 5.6 |
| Dash-Mounted Brake Controls .....                 | 5.7 |

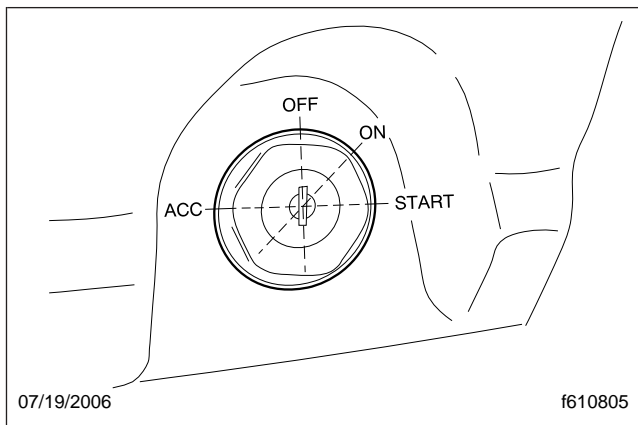
# Driver Controls

## Steering Column and Left-Hand Dash Controls

### Ignition and Key Switch

The ignition switch is located on the lower portion of the left-hand dash.

The ignition switch has four positions: ACC, OFF, ON, and START. In the OFF position, the key slot is vertical; the key can be inserted and removed only in this position. See [Fig. 5.1](#).



**Fig. 5.1, Ignition Switch**

In the ACC (accessory) position, the key is turned counterclockwise. The auxiliary (bunk) fan, windshield fan(s), radio or stereo system, mirror heat, ether start system, air dryer, backup lights, and all of the electrical systems that are operable in the off position are operable.

The low-beam headlights, taillights, brake lights, road lights, dome lights, clearance lights, turn signals, hazard lights, refrigerator, fuel heater, electric oil pan heater, and electric or diesel-fired engine-coolant pre-heaters can be operated in the off position (regardless of whether the key is inserted).

In the ON position, the key is turned clockwise. All electrical systems are operable. Low air- and oil-pressure warning lights (or messages) and buzzer operate until the engine is started and pressure is built up. The engine can be started and operated only when the ignition switch is ON.

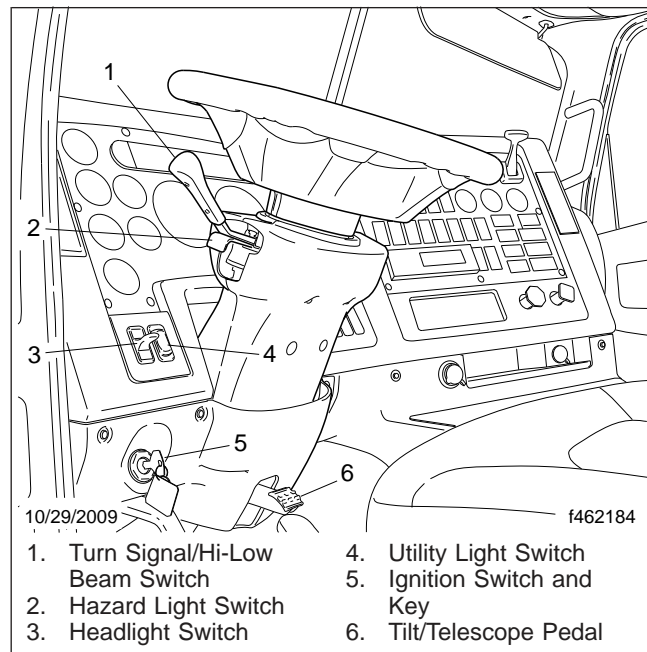
**NOTE:** Switching on the ignition and releasing the parking brakes automatically activates the daytime running lights. The daytime running

lights will operate until the parking brakes are applied, then they will switch off. They can also be turned off with an optional override switch.

The ignition key also locks and unlocks the cab doors, the baggage door(s) and if equipped, the bunk door(s).

### Headlight Switch

A three-position headlight switch on the left-hand dash is used to operate the exterior lights. When the switch is in the upper-most position, the headlights and all other vehicle lights are on. All vehicle lighting is off when the switch is in the middle position. When the switch is in the downward position, only the clearance, instrument panel, marker lights, and the taillights are illuminated. See [Fig. 5.2](#).



**Fig. 5.2, Steering Column and Left-Hand Dash**

Switching ON the ignition and releasing the parking brakes automatically activates the daytime running lights, if equipped. The daytime running lights will operate until the parking brake is applied or the headlights are turned on.



## Utility Light Switch

Utility lights can be swivel-mounted on top of the cab, mounted on the cab side-extender, or flush-mounted in the back of the cab or sleeper. They are turned ON and OFF using the switch (UTLY LAMP) located next to the headlight switch. See [Fig. 5.2](#).

## Turn Signal Lever

The turn signal lever is mounted on the steering column. See [Fig. 5.2](#). Moving the lever counterclockwise turns on the left-turn signal lights; moving it clockwise turns on the right-turn signal lights. When one of the turn signal lights is on, a green indicator light flashes at the far left or far right of the warning and indicator light panel. To cancel the signal, move the lever to the neutral position. Some style levers may have automatic cancelling, and the turn signal lever automatically returns to the neutral position when the steering wheel returns to the straight-ahead position after a turn.

## Headlight Dimmer

Pull the turn signal lever toward the steering wheel to change from low-beam to high-beam headlights or from high beam back to low beam.

When the headlights are on high beam, a blue light on the indicator light panel comes on. For vehicles built to operate in the United States, switching from low beams to high beams will switch off the road lights.

**NOTE:** The ignition switch must be on for the high beams to work.

## Hazard Warning Light Switch Tab

The hazard warning light switch tab is located underneath the turn signal lever. See [Fig. 5.2](#). Hazard warning lights are operated by pulling the tab out. When the hazard warning light switch tab is pulled out, all of the turn signal lights and both of the indicator lights on the control panel will flash. To cancel the warning lights, move the turn signal lever up or down.

## Adjustable Steering Column



**Make sure that the steering column is locked before driving the vehicle. Never tilt the column while driving the vehicle. Doing so could cause loss of vehicle control, personal injury, and property damage.**

For the optional tilt-steering column, the control pedal is located on the column below the steering wheel. See [Fig. 5.2](#).

After adjusting the seat to the desired ride position, unlock the steering column by pushing and holding the control pedal all the way down. Tilt the steering column to the desired position, then release the control pedal to lock the steering column in place.

## Electric Horn

The button for the electric horn is located in the center of the steering wheel. To sound the horn, press down on the button. The horn will sound for the duration that the button is pressed, up to 60 seconds. The electric horn will operate regardless of the position of the ignition key.

## Door Mounted Controls

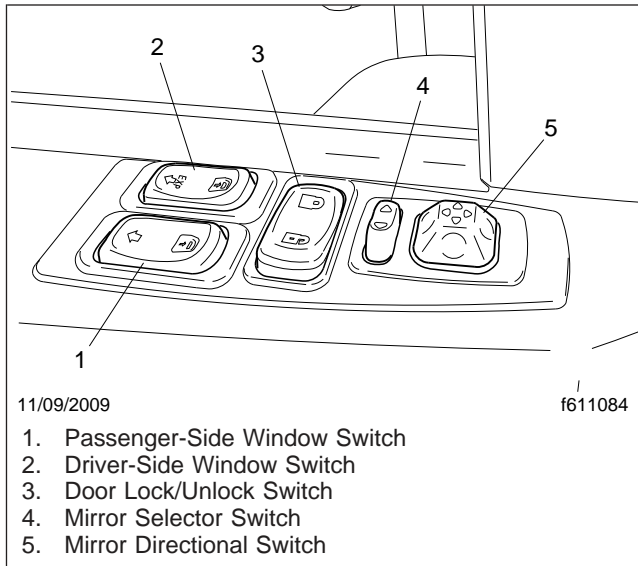
The driver's door control panel has power switches to control the driver's and passenger's windows, door locks, and door mirror adjustments. See [Fig. 5.3](#).

Power windows are standard on 122SD and Coronado vehicles. In addition to the control on the driver's door, the passenger door has a switch mounted in the top of the door, that controls the passenger-side power window.

**IMPORTANT:** There is no anti-pinch protection when the window is almost closed. Be sure to clear all objects from the window before closing.

The window switches have three positions: lower window, neutral, and raise window. Press forward on the switch to raise the window. Press the switch in the rearward position to lower the window. Hold the switch down for approximately one second to activate the express function; the window will continue to roll up or down after the switch is released.

# Driver Controls



**Fig. 5.3, Driver's Door Mounted Switches**

Pressing the power door lock switch opens or locks both the driver's and passenger's doors simultaneously.

To adjust the mirrors, first use the selector to activate either the left or the right mirror, then use the directional switch to aim them inward, outward, upward or downward. See [Fig. 5.3](#).

## Air Horn

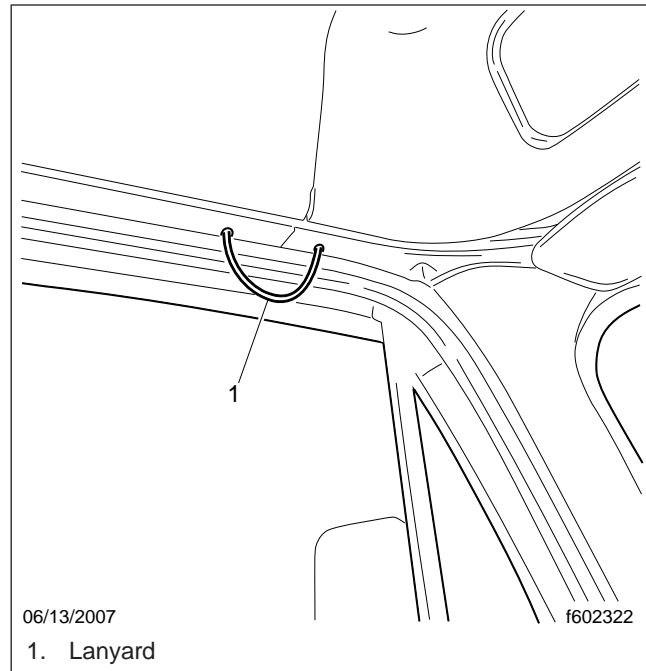
Air horns may be mounted on the roof of day cabs, or under the driver-side floor for sleeper cabs. The air horn is controlled by a wire lanyard that hangs down inboard by the driver's door. See [Fig. 5.4](#). Pull downward on the lanyard to sound the air horn.

## Lower Right-Hand Dash Panel Switches

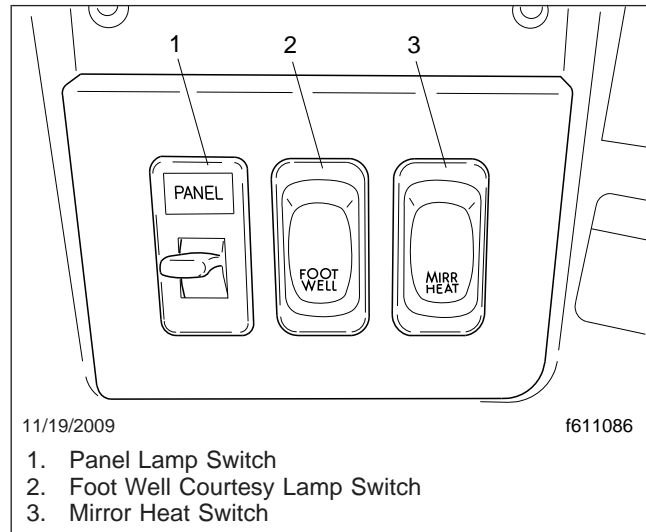
The lower right-hand dash has a small electrical switch panel with room for three switches. Typically it houses the panel lamp dimmer switch, the footwell courtesy lamp switch, and the mirror heat switch. See [Fig. 5.5](#).

### Panel Lamps Control Switch

The circuit to the panel lamps is activated by the headlight switch. When the headlights are turned on the panel lamps are illuminated. The intensity of the



**Fig. 5.4, Air Horn Control**



**Fig. 5.5, Lower RH Dash Panel Switches**

instrument panel lamps can be controlled with the panel lamp switch. Slide the switch toggle up to brighten them and down to dim them. See [Fig. 5.5](#).

## Foot Well Courtesy Lamp Switch

Courtesy lights illuminate the footwell area on both sides of the cab, and the bottom of the door panels. The driver's courtesy light is located on the steering column and the passenger's footwell light is located on the lower right dash panel. There is also a courtesy light in the lower portion of each cab door. The courtesy lights activate when a door is opened or with the dash switch. See [Fig. 5.5](#).

## Mirror Heat Switch

The outside mirrors can be heated to keep them clear of fog, frost, and ice. In order for the heated mirrors to operate, the key must be turned to ON. Press the upper part of the mirror heat switch to activate it. See [Fig. 5.5](#).

## Main Dash Switches

See [Fig. 5.6](#) for a general layout of main dash electrical switches.

**NOTE:** See [Chapter 10](#) in this manual for details on operating the cruise control, and the engine brake.

## Marker Lights Interrupt Switch

The marker lights interrupt (MRKR INT) switch temporarily deactivates the marker lights and taillights. With the vehicle lights on, raise and hold the paddle switch to briefly turn off the marker lights and taillights. To alert the driver that the switch is functioning, the dash lights will flash with the marker lights when the switch is actuated. When the paddle is released the marker lights will return to normal operation. See [Fig. 5.6](#).

## Road Lamp Switch

The optional road lamp (ROAD LAMP) switch (see [Fig. 5.7](#)) operates the road lights mounted on the bottom edge of the front bumper or recessed in the front bumper.

For vehicles built to operate in the United States, the low beam headlights must be turned on before the road lamps can be turned on. The road lamps will not illuminate if the high beam headlights are already on, and switching from low beams to high beams will switch off the road lamps. For vehicles built to oper-

ate in Canada, the marker lights must be on before the road lamps can be turned on.

## Regen Switch

A parked regen of the aftertreatment system can be initiated with the regen switch. See [Fig. 5.6](#).

Refer to [Chapter 11](#) for instructions on how to perform a parked regen.

An optional inhibit regen switch provides additional control over the aftertreatment regeneration process. When activated, the inhibit switch will stop a regeneration cycle in progress, and prevent the start of a regeneration cycle until the switch is no longer active. See [Fig. 5.8](#).

## ATC Switch

The Automatic Traction Control (ATC) switch is a momentary switch. Briefly push the top of the switch to activate or deactivate it. See [Fig. 5.6](#).

The ATC system limits wheel spin when power is applied to the drive axles during reduced-traction situations. When the ATC is active, the ATC will apply gentle braking to the spinning wheel, to force power to the wheel(s) with better traction. If both wheels are spinning, the system will signal the electronic engine to reduce power.

Pressing the ATC switch will temporarily allow more drive wheel spin, to help burn through a thin layer of ice, or to help throw off accumulated mud or snow. When the switch is activated, an ATC or WHEEL SPIN icon located in the driver's message center will blink slowly. Pressing the switch again will cycle the system back to normal operation.

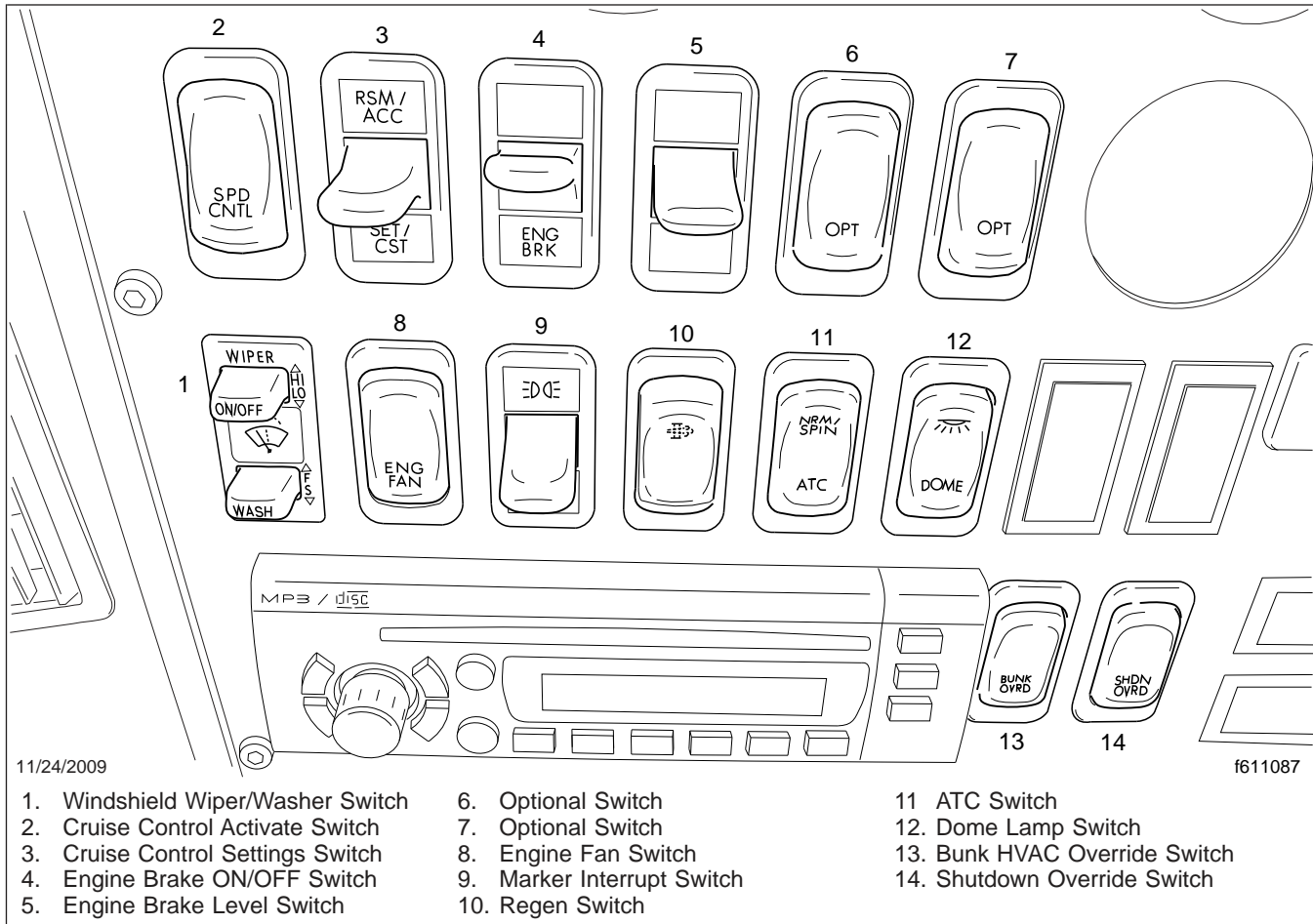
## Engine Fan Switch

The engine cooling fan can be manually activated with the engine fan switch. The fan will continue to operate for a set amount of time and then turn off unless the coolant temperature is high enough to continue the fan operation. To turn the engine fan on, press on the upper part of the switch. Press the bottom of the switch to deactivate it. See [Fig. 5.6](#).

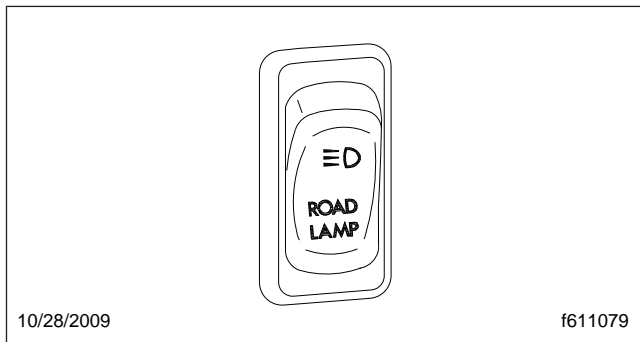
## Trailer Auxiliary Switch

Trailers that are equipped with pneumatic brakes and used in North America or South America are generally equipped with an electrical cable that terminates in a 7-way connector. Power for the trailer lights is

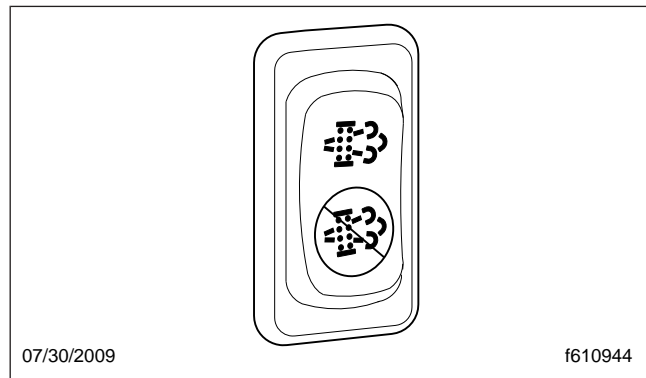
# Driver Controls



**Fig. 5.6, Main Dash Switches**



**Fig. 5.7, Road Lamp Switch**



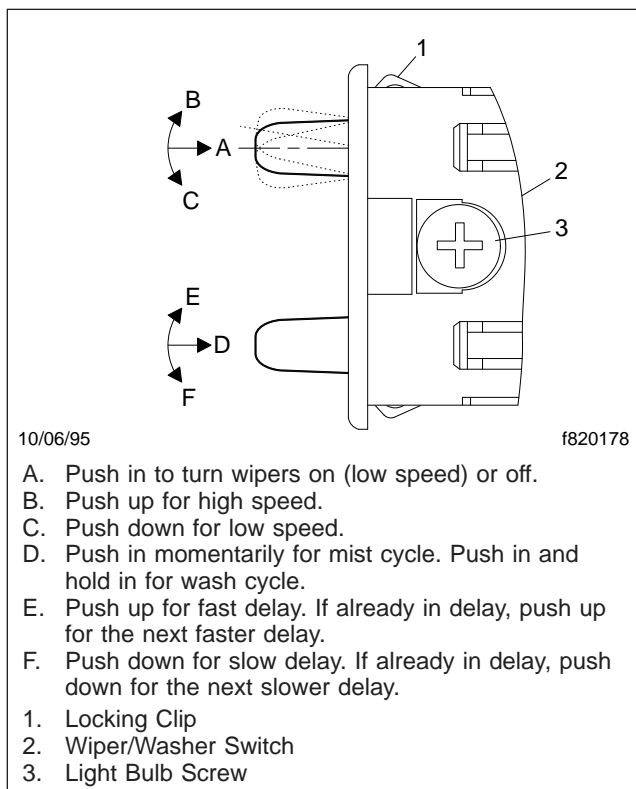
**Fig. 5.8, Regen Inhibit Switch**

passed from the vehicle to the trailer via the primary receptacle, controlled by the dash switch. Press the top of the Trailer Auxiliary switch to activate it. Press the bottom of the switch to turn it off.

## Windshield Wiper/Washer

### Dash Controls

The wipers are operated by a double-paddle WIPER/WASH switch mounted on the main dash panel. The top paddle, when pushed in, turns the wipers on (if they are off) or off (if they are on). When it is pushed up, the top paddle switches the wipers to high speed; when it is pushed down, it switches them to low speed. See [Fig. 5.9](#).



**Fig. 5.9, Wiper/Washer Switch Operation**

The bottom paddle, when pushed in, turns the washers on. When pressed for less than 1/2-second, the wipers will perform a single, low speed dry wipe (mist function). When pressed for more than 1/2-second, the wash cycle begins and continues for three cycles or until the paddle is released. When the bottom paddle is pushed up, the wipers operate in fast delay. When the bottom paddle is pushed down, the wipers operate in slow delay. With the wipers in delay mode (fast or slow), push the bottom paddle up to shorten the delay period or push the paddle down to lengthen it.

### NOTICE

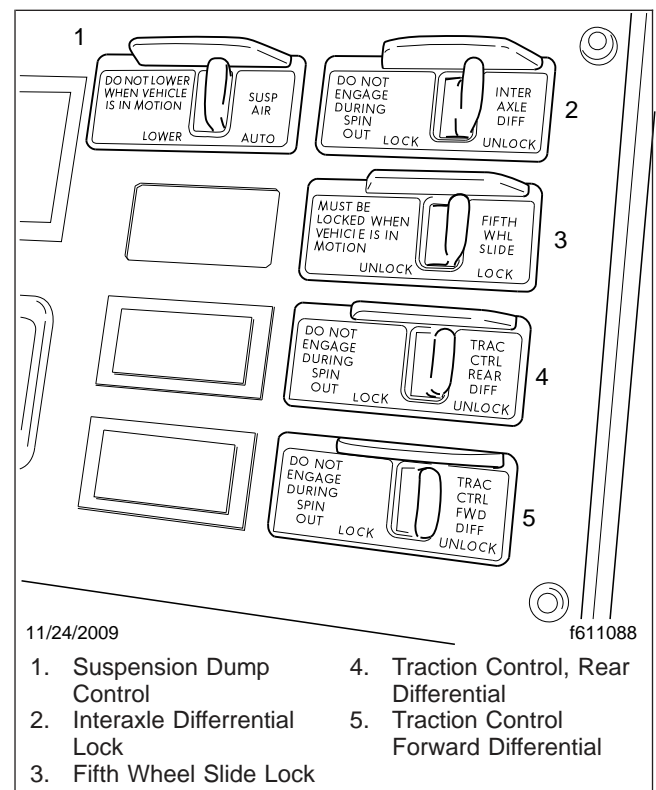
**Do not move the wiper arms manually. Wiper motor damage will occur if the arms are moved.**

### Windshield Washer Fluid Reservoir

The windshield washer reservoir is located under the hood, near the firewall on the driver's side. Remove the cap from the filler neck to add windshield washer fluid.

### Guarded Switches

**IMPORTANT:** The following switches are guarded to prevent unintentional switch activation. See [Fig. 5.10](#).



**Fig. 5.10, Guarded Switches**

### Air Suspension Dump Control

The air-suspension height switch may be used to aid in connecting or disconnecting from a trailer. When the switch is set to LOWER, the air-suspension

# Driver Controls

---

dump valve deflates the air springs to lower the rear of the vehicle. When the switch is moved back to the normal position, the suspension will return to the correct ride height. A guard is positioned around the switch to minimize accidental activation. See [Fig. 5.10](#).

## NOTICE

**Do not operate the vehicle over uneven ground such as ramps, speed bumps, curbs, etc. with the air springs deflated. Doing this may lead to air bag separation from the piston, preventing the suspension air springs from reinflating.**

## NOTICE

**Never exhaust air from the suspension while driving. When the air is exhausted, the suspension will not absorb road shocks, and components may be damaged.**

## Interaxle Differential Lockout Control

## NOTICE

**The interaxle lock should only be engaged when the vehicle is moving slowly at low throttle. Engagement at high speed or power can damage the axle(s).**

The interaxle lock, standard on all dual-drive vehicles, is driver-actuated by means of a LOCK/UNLOCK control valve switch mounted on the control panel. See [Fig. 5.10](#). A red indicator light comes on whenever the interaxle differential is locked out (switch is in the lock position; no differential action between the drive axles). A guard around the switch minimizes accidental activation.

## Fifth Wheel Air Slide Control

## NOTICE

**Do not activate the fifth wheel slide control valve while the vehicle is in motion. To do so could cause damage to the fifth wheel member, the kingpin, the cab or trailer, and ultimately to the drivetrain.**

The fifth wheel air slide valve permits repositioning of the sliding fifth wheel from inside the cab. Moving the

air slide control valve switch to the lock position deactivates the control valve and locks the fifth wheel to the baseplate. See [Fig. 5.10](#). Moving the switch to the unlock position activates the control valve and unlocks the fifth wheel slide mechanism, allowing changes to the total length of the tractor-trailer and changes to axle loads to comply with varying state or provincial laws. A red indicator light, if so equipped, is illuminated whenever the fifth wheel slide is unlocked. A guard is positioned around the switch to minimize accidental activation.

## Controlled Traction Differential Control

A controlled traction differential feature is included or available as an option on some rear axles. A control valve switch engages and disengages the controlled traction feature to cause the axle shafts to rotate together. See [Fig. 5.10](#). The controlled traction, or differential lock, should only be engaged when the vehicle is moving slowly at low throttle to avoid causing internal axle damage. The differential lock must only be used for adverse road conditions. The use of the lock increases the turning radius and affects the vehicle handling. A guard is positioned around the switch to minimize accidental activation.

## Dash-Mounted Brake Controls

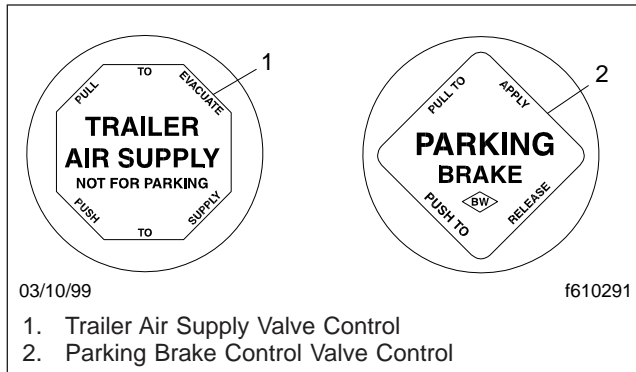
### Parking Brake Control Valve and Trailer Air Supply Valve

## NOTICE

**Do not step on the service brake pedal while the parking brakes are applied. To do so can cause damage to the brake mechanisms.**

The yellow diamond-shaped knob operates the parking brake valve. Pulling the knob applies both the tractor and the trailer spring parking brakes. See [Fig. 5.11](#). Pushing the knob in releases the tractor spring parking brakes. Before the spring parking brakes can be released, the air pressure in either air brake system must be at least 65 psi (447 kPa).

The red octagonal-shaped knob operates the trailer air supply valve. See [Fig. 5.11](#). After the vehicle and its air hoses are connected to a trailer and the pressure in the air system is at least 65 psi (447 kPa), the trailer air supply valve knob must be pushed in (and should stay in) to charge the trailer air supply system and release the trailer spring parking brakes.



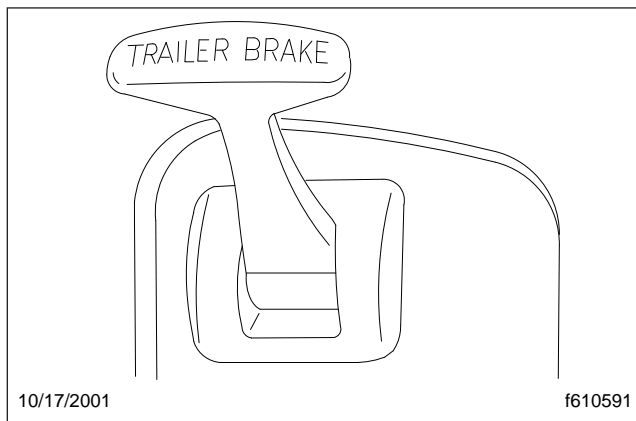
**Fig. 5.11, Dash Brake Valve Controls**

Before disconnecting a trailer or when operating a vehicle without a trailer, the trailer air supply valve knob must be pulled out.

See [Chapter 12](#), Brake System, for complete brake operating instructions.

## Trailer Brake Hand Control Valve Lever

The trailer brake lever (hand control valve) is used for applying the trailer brakes without applying the truck or tractor brakes. It is usually mounted on the right-hand control panel. See [Fig. 5.12](#). See [Chapter 12](#), Brake System, for complete brake operating instructions.



**Fig. 5.12, Trailer Brake Lever**

# 6

## Seats and Restraints

---

|                                   |      |
|-----------------------------------|------|
| Seats, General Information .....  | 6.1  |
| Freightliner High-Back Seat ..... | 6.2  |
| EzyRider® Seat .....              | 6.2  |
| Bostrom Seat .....                | 6.4  |
| Sears Atlas Seat .....            | 6.5  |
| National 2000 Series Seat .....   | 6.5  |
| ABTS Seat .....                   | 6.6  |
| Seat Belts and Tether Belts ..... | 6.7  |
| Steering Wheel Air Bag .....      | 6.11 |



# Seats and Restraints

## Seats, General Information

Unless otherwise noted, all seat adjustments should be made while seated and before the engine is started.

Due to the high degree of adjustability of mid- and high-back air suspension seats, it is possible to combine the seat back recline adjustment and the seat slide adjustment so that the seat back contacts the back wall. Use care when adjusting the seat to prevent damage to the seat and the cab interior.

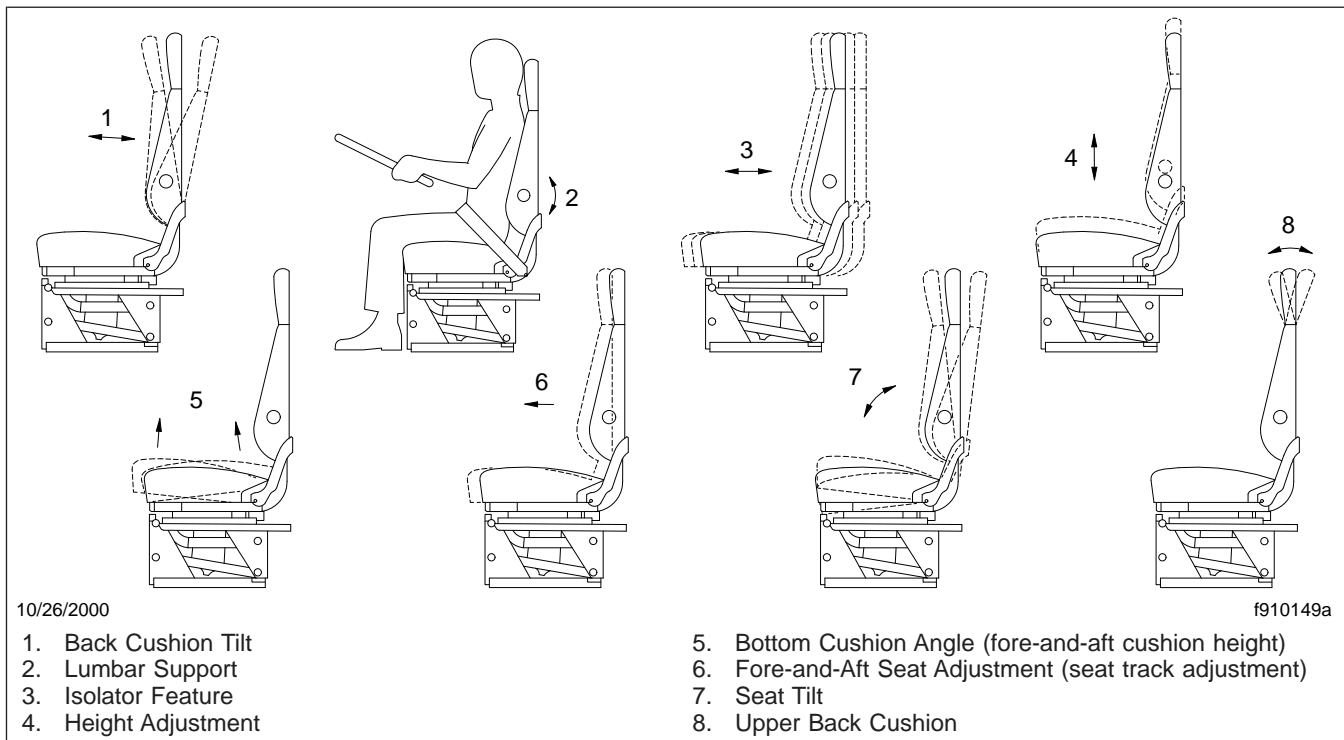
### **WARNING**

**Keep hands, tools, and other objects away from the scissor points under the seats. Failure to do so could cause personal injury.**

The following is a description of adjustments that can be made to various Freightliner-installed seats. Not all seats have all of the adjustments listed below. See [Fig. 6.1](#).

1. Back Cushion Tilt: This adjustment enables the back cushion to pivot forward or backward.

2. Lumbar Support: Lumbar support changes the shape of the seat back to give more, or less, support to the occupant's lumbar (lower back) area. This adjustment is either mechanical or air controlled, depending on make and model of the seat.
3. Isolator: This feature reduces the amount of road shock by isolating the occupant from the motion of the vehicle, and allowing the upper seat to move in a simple pendulum motion. A lockout feature is used whenever the isolator is not desired.
4. Height Adjustment: The entire seat moves up or down when adjusting the height. The adjustment is either manually or air controlled, depending on the make of the seat.
5. Bottom Cushion Angle, or Fore-and-Aft Bottom Cushion Height: This feature enables the occupant to raise or lower the front or back of the bottom cushion. This adjustment is easier to perform when all weight is removed from the seat.



**Fig. 6.1, General Seat Adjustments**

6. **Fore-and-Aft Seat (seat track adjustment):** The entire seat moves forward or backward when this adjustment is made.
7. **Seat Tilt:** When this adjustment is made, the seat assembly (back and bottom cushions) tilts forward or backward.
8. **Upper Back Cushion Adjustment:** When this adjustment is made, the upper back cushion changes angle to provide upper back support.
9. **Weight Adjustment:** On those seats with weight adjustment, the feature is fully automatic. When you sit on the seat, a leveling valve places you in the center of the ride zone. Additional adjustments are possible by using the height adjustment feature.

## Freightliner High-Back Seat

See [Fig. 6.2](#) for seat adjustment controls. Not all models of the seat have all the adjustments listed below.

### Backrest Tilt

To tilt the backrest, lean forward slightly to remove pressure from the cushion, then turn the knob forward or rearward to achieve the desired position.

### Lumbar Support

To adjust the lumbar support, use the lumbar support switches on the side of the seat.

### Height Adjustment

To raise or lower the height of the seat, use the height adjustment switch on the side of the seat.

### Bottom Cushion Extension

To adjust the fore-and-aft position of the seat cushion, remove your weight from the seat, then lift up and pull forward on the cushion adjustment handle. To return the cushion to the aft position, lift up and push rearward.

### Fore/Aft Seat Slide

To adjust the fore-and-aft position of the entire seat, move the fore-and-aft seat adjustment lever to the left and slide the seat forward or backward to the

desired position. Move the lever back to its original position to lock the seat in place.

### Fore/Aft Isolator

To engage the isolator, turn the isolator knob rearward to the unlocked position. Turn the isolator knob forward to the locked position when the isolator feature is not desired.

### Shock Absorber

To adjust the amount of damping the shock absorber provides, move the lever up to increase damping; move the lever down to decrease damping.

### Front Cushion Height

To adjust the height of the front of the cushion, remove your weight from the seat, then turn the adjustment knob toward the front of the seat (clockwise) to increase cushion height. To lower the cushion height, turn the adjustment knob toward the rear of the seat (counterclockwise).

### Rear Cushion Height

To adjust the height of the rear of the seat cushion, remove your weight from the seat and turn the rear cushion adjustment knob to one of three positions.

### Heater

To turn on the heat option, press the button. To turn off the heat option, press the button again. If the vehicle has Optimized Idle, seat heating will not operate with the key in accessory mode. Optimized Idle may also turn seat heating off to reduce stress on the batteries. Refer to [Chapter 10](#) for more information about Optimized Idle.

## EzyRider® Seat

For EzyRider seat adjustment controls, see [Fig. 6.3](#).

### Back Cushion Tilt

To tilt the back cushion, raise the back cushion tilt lever and lean forward or backward. Release the lever to lock the cushion in place.

# Seats and Restraints

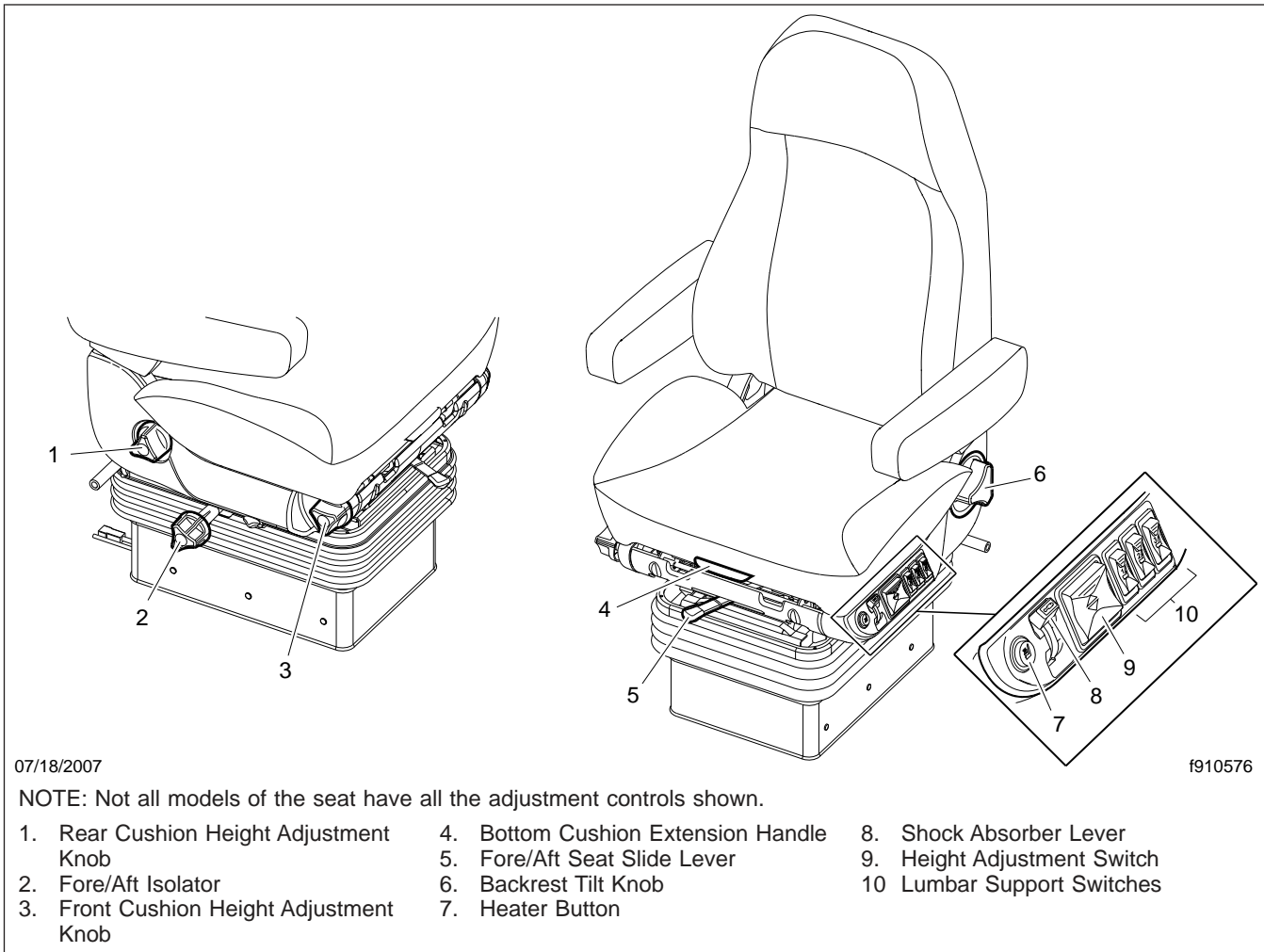


Fig. 6.2, Freightliner High-Back Seat

## Lumbar Support

To adjust the amount of support for your lower back, push the front of the switch to inflate the lower lumbar bag, push the rear of the switch to deflate the bag. .

## Isolator

Move to left allows isolation; to right locks isolator.

## Fore-and-Aft Slide Adjustment

To adjust the fore-and-aft position of the entire seat, lift the bar and slide the seat to the desired position.

## Height Adjustment

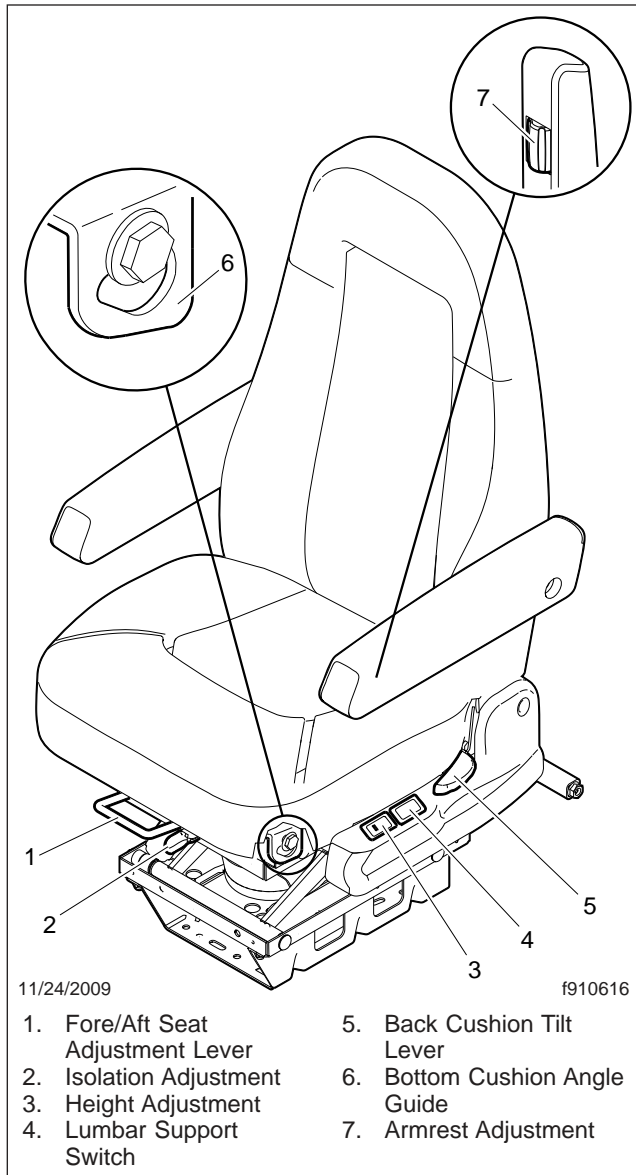
To raise or lower the seat, use the height adjustment switch on the side of the seat.

## Bottom Cushion Angle

To adjust the bottom cushion angle, pull the bottom cushion up and forward or down and back. The bottom cushion angle is controlled by the guides on each side of the seat.

## Armrest Angle (optional armrests)

To adjust the vertical angle of the armrest, turn the adjustment knob on the underside of the armrest.



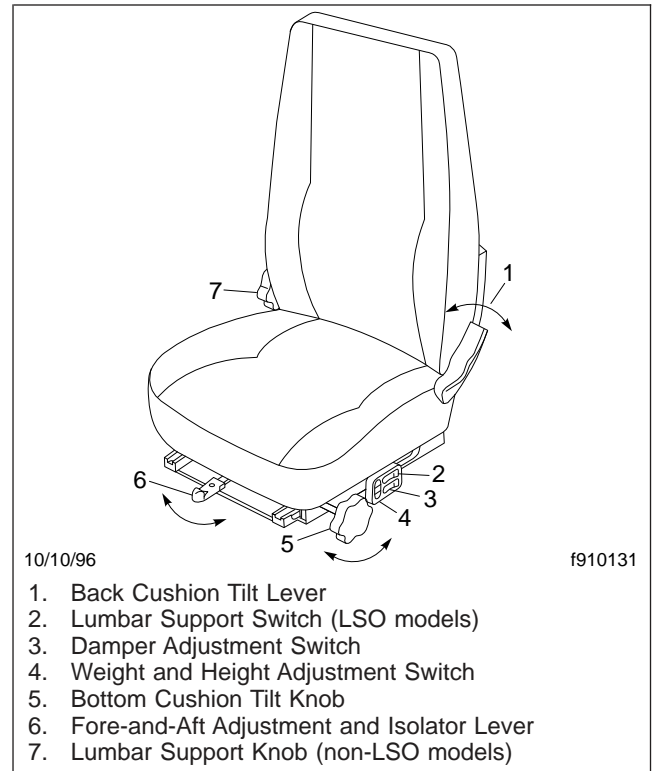
**Fig. 6.3, EzyRider Seat Adjustment Controls**

## Bostrom Seat

See [Fig. 6.4](#) for Bostrom seat adjustment controls.

### Back Cushion Tilt

To tilt the back cushion, lean forward slightly to remove pressure from the cushion then hold the back cushion tilt lever rearward. Lean backward slowly to



**Fig. 6.4, Bostrom Seat Adjustment Controls**

the desired position and release the lever to lock the cushion in place.

### Weight and Height Adjustment

To raise the seat, press the upper portion of the weight and height adjustment switch. To lower the seat, press the lower portion of the switch.

### Isolator

To engage the isolator, put the isolator lever in the center position. Lock out the isolator by moving the lever to the right.

### Fore-and-Aft Seat Adjustment

Hold the fore-and-aft adjustment lever to the left and slide the seat forward or backward to the desired position.

### Bottom Cushion Tilt Adjustment

Rotate the bottom cushion tilt knob to increase or decrease bottom cushion tilt.

# Seats and Restraints

## Lumbar Support

To increase lumbar support on LSO models, press the plus sign on the lumbar support switch. To decrease lumbar support on LSO models, press the minus sign on the switch. To increase lumbar support on non-LSO models, rotate the lumbar support knob forward. To decrease lumbar support on non-LSO models, rotate the knob rearward.

## Damper Adjustment

Press the damper adjustment switch to adjust the damper.

## Sears Atlas Seat

See [Fig. 6.5](#) for seat adjustment controls.

## Isolation Adjustment

Position the handle to the left to allow isolation movement. Position the handle to the right to lock-out isolation movement.

## Fore-and-Aft Slide Adjustment

To adjust the fore-and-aft position of the entire seat, lift the bar and slide the seat to the desired position.

## Seat Tilt/Extension Adjustment

Lift the handle upward and move the seat cushion to the desired position. Three positions are available.

## Backrest Adjustment

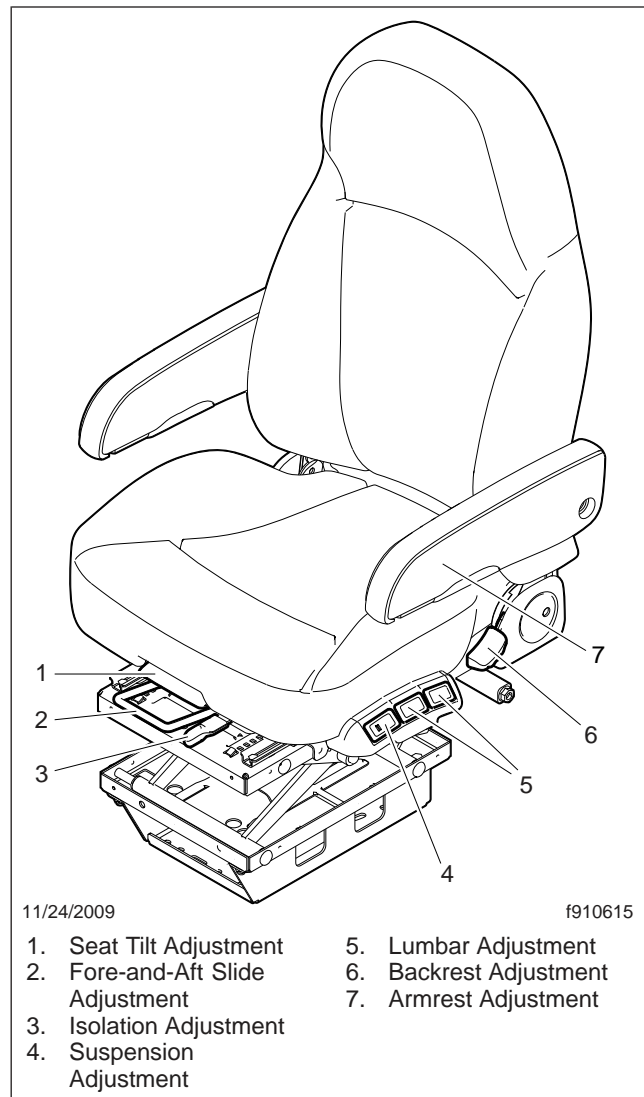
Pull upward on the recliner handle, lean backward to desired position and release handle. To adjust backrest forward, pull upward on the recliner handle while leaning forward.

## Suspension (Ride) Adjustment

Push forward on the front rocker switch to inflate and raise the suspension; push rearward to deflate and lower the suspension.

## Lumbar Adjustment

Rear rocker switch: push forward to inflate the lower lumbar bag; push rearward to deflate the bag. Center rocker switch: push forward to inflate the upper lumbar bag; push rearward to deflate the bag.



**Fig. 6.5, Sears Atlas Seat Adjustment Controls**

## Armrest Adjustment

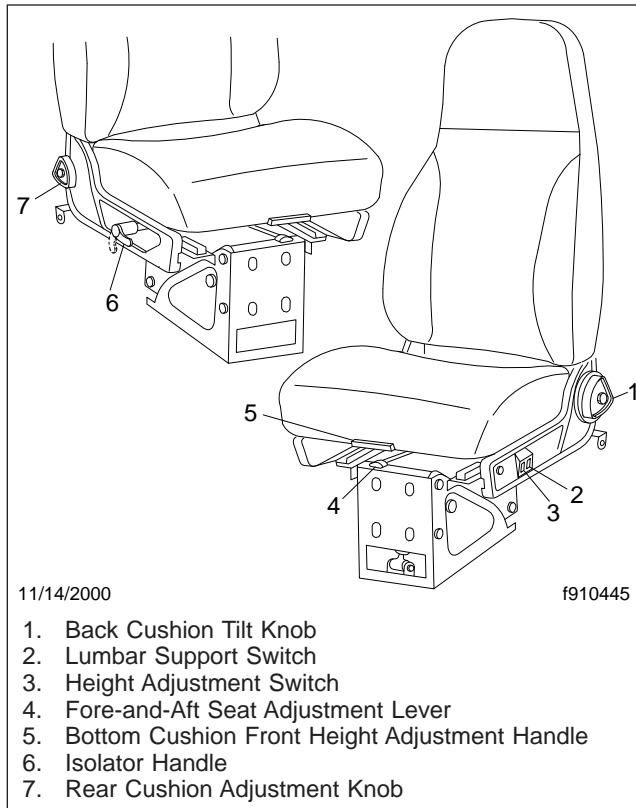
Rotate the control knob, located on the underside of the armrest, to set the desired angle of the armrest.

## National 2000 Series Seat

See [Fig. 6.6](#) for seat adjustment controls.

## Back Cushion Tilt

To tilt the back cushion, turn the back cushion tilt knob until the desired position is reached.



**Fig. 6.6, National 2000 Series Seat Adjustment Controls**

## Height Adjustment

To raise or lower the height of the seat, use the height adjustment switch on the side of the seat.

## Fore-and-Aft Seat Adjustment

To adjust the fore-and-aft position of the entire seat, move the fore-and-aft seat adjustment lever to the left and slide the seat forward or backward to the desired position. Move the lever back to its original position to lock the seat in place.

## Rear Cushion Adjustment

To adjust the height of the rear of the seat cushion, remove your weight from the seat and turn the rear cushion adjustment knob to one of three positions.

## Isolator

Also called a Chugger Snubber®, the isolator reduces the amount of road shock by isolating the oc-

cupant from the motion of the vehicle and allowing the seat to move in a simple pendulum motion. To use the isolator feature, turn the isolator handle to the horizontal position. Turn the isolator handle down when the isolator feature is not desired.

## Lumbar Support

To adjust the lumbar support, use the lumbar support switch on the side of the seat to give more or less support to your lower back.

## Bottom Cushion Front Height

To adjust the height of the front of the bottom cushion, lift the bottom cushion front height adjustment handle, and pull forward or push back to the desired setting.

## ABTS Seat

See [Fig. 6.7](#) for ABTS (all-belts-to-seat) seat adjustment controls.

## Cushion Extension Adjustment

Move the cushion extension adjustment lever to the left and move the seat cushion to the desired position.

## Track Adjustment

To adjust the fore-and-aft position of the entire seat, lift the track adjustment handle and slide the seat to the desired position.

## Isolator

Pull up the isolator control handle to lock out the isolation movement.

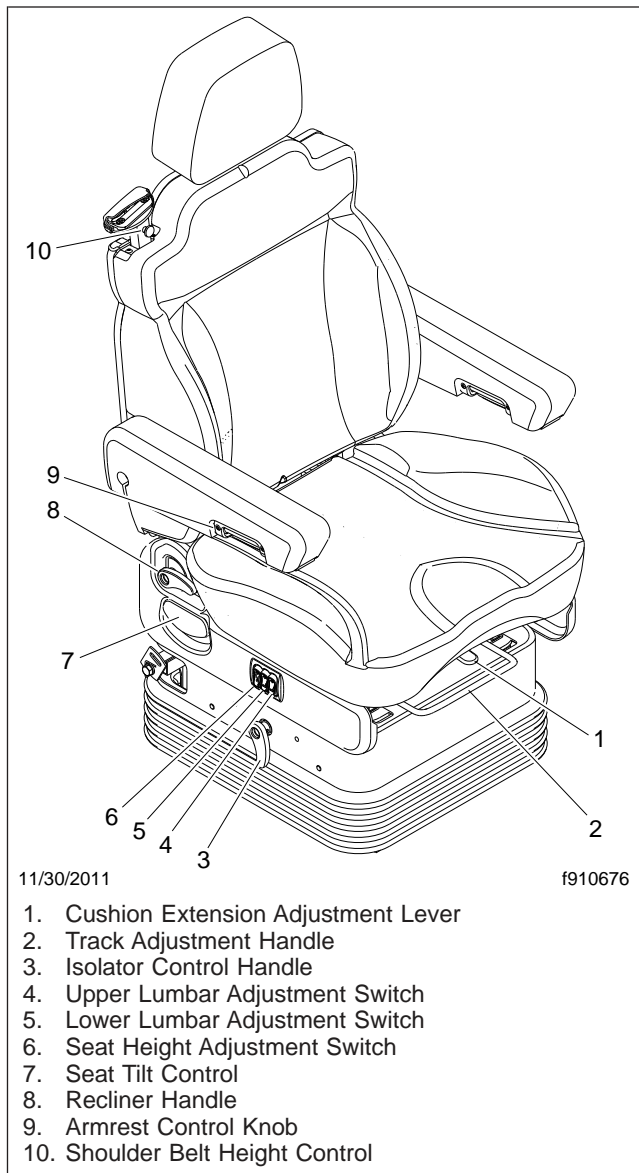
## Lumbar Adjustment

Push the middle rocker switch to adjust the lower lumbar bag. Push the forward switch to adjust the upper lumbar bag.

## Seat Height Adjustment

Push the seat height adjustment switch to raise or lower the seat suspension.

# Seats and Restraints



**Fig. 6.7, ABTS Seat Adjustment Controls**

## Seat Tilt Control

Set the seat tilt control to one of the five positions to set cushion rake adjustment.

## Backrest Adjustment

To tilt the backrest backward, pull up on the recliner handle while leaning backward. To tilt the backrest

forward, pull up on the recliner handle while leaning forward.

## Armrest Adjustment

Rotate the control knob, located on the underside of the armrest, to set the desired angle of the armrest.

## Shoulder Belt Height Control

Adjust the shoulder belt height. The height can be adjusted vertically by 3 inches (75 mm).

## Seat Belts and Tether Belts

### General Information

Seat belt assemblies are designed to secure persons in the vehicle to help reduce the chance of injury, or the amount of injury, resulting from accidents or sudden stops. For this reason, Daimler Trucks North America LLC urges that the driver and *all* passengers, regardless of age or physical condition, use seat belts when riding in the vehicle.

### **⚠ WARNING**

**Always use the vehicle's seat belt system when operating the vehicle. Failure to do so can result in severe personal injury or death.**

Seat belt assemblies in Daimler Trucks North America (DTNA) vehicles meet Federal Motor Vehicle Safety Standard 209, "Type 1" and "Type 2" requirements.

When transporting a child, always use a child restraint system or the vehicle seat belts as appropriate. To determine whether a child restraint system is required, review and comply with applicable state and local laws. Any child restraint used must comply with Federal Motor Vehicle Safety Standard 213, "Child Restraint Systems." When providing a child restraint system, always carefully read and follow all instructions pertaining to installation and usage for the child. Make certain the child remains in the restraint system at all times when the vehicle is in motion.

In addition to seat belt assemblies, tether belts are installed on suspension-type seats. Tether belts provide a flexible extension of the cab structure. They help secure the seat to the floor, and are intended to

restrain the seat and seat belt in case of an accident or sudden stop.

**IMPORTANT:** Seat belts and tethers have a finite life which may be much shorter than the life of the vehicle. Regular inspections and replacement as needed are the only assurance of adequate seat belt security over the life of the vehicle.

## Seat Belt Inspection

### **WARNING**

**Inspect and maintain seat belts. When any part of a seat belt system needs replacement, the entire seat belt must be replaced, both retractor and buckle side. Any time a vehicle is involved in an accident, and the seat belt system was in use, the entire vehicle seat belt system must be replaced before operating the vehicle. Do not attempt to modify the seat belt system; doing so could change the effectiveness of the system. Failure to replace worn or damaged seat belts, or making any modifications to the system, may result in personal injury or death.**

Inspect the seat belts and tether belts (if so equipped).

1. Check the web for fraying, cuts, extreme dirt and dust, or for severe fading from exposure to sunlight, especially near the buckle latch plate and in the D-loop guide area.
2. Check operation of the buckle, latch, Komfort Latch or Sliding Komfort Latch (if equipped), web retractor, and upper seat belt mount on the door pillar. Check all visible components for wear or damage.
3. Check the seat belt and tether belt connection points and tighten any that are loose.

## Seat Belt Operation

### Three-Point Seat Belt With Komfort Latch or Sliding Komfort Latch

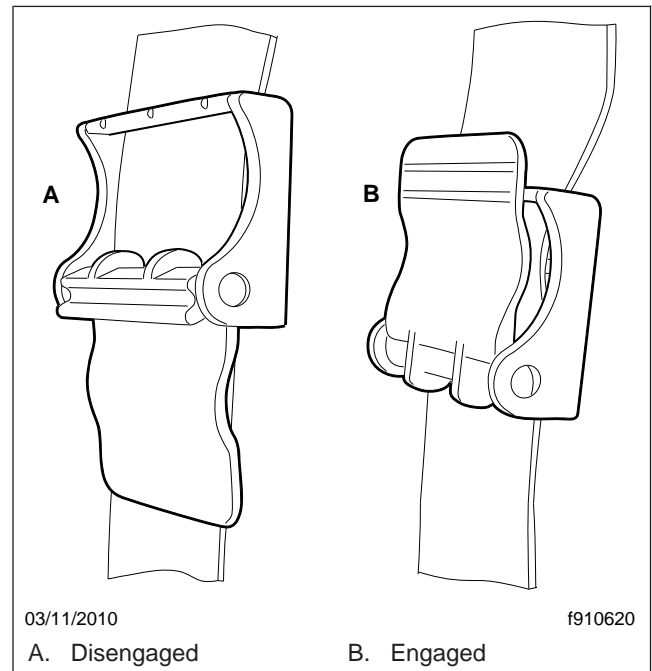
**NOTE:** For vehicles not equipped with the Komfort Latch or the Sliding Komfort Latch, see the seat belt operation under the heading "Three-Point Seat Belt."

### **WARNING**

**Wear three-point seat belts only as described below. Three-point seat belts are designed to be worn by one person at a time. In case of an accident or sudden stop, personal injury or death could result from misuse.**

**Fasten the seat belts before driving. Fastening a three-point seat belt while driving creates a hazard.**

When engaged and used properly, the Komfort Latch (Fig. 6.8) and the Sliding Komfort Latch (Fig. 6.9) introduce a small amount of slack into the seat belt, resulting in a more comfortable ride.



**Fig. 6.8, Komfort Latch**

1. Slowly pull the latch end of the three-point seat belt out of the retractor and pull it across your lap (from outboard to inboard) far enough to engage the buckle. If the retractor locks too soon, allow the belt to retract slightly, then slowly pull it out again. See Fig. 6.10.
2. Fasten the three-point seat belt by pushing the latch into the buckle. Listen for an audible click.



# Seats and Restraints



**Fig. 6.9, Sliding Komfort Latch**

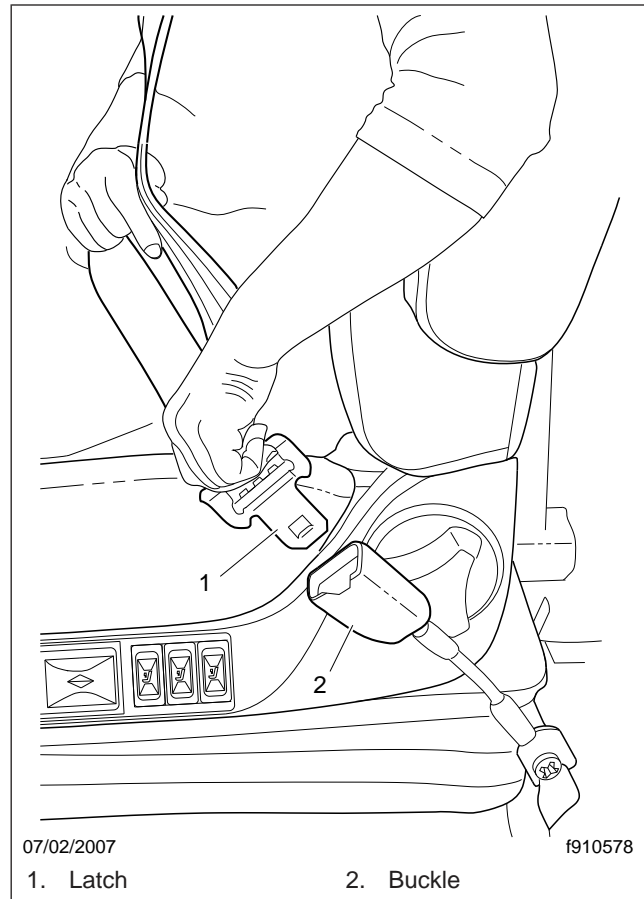
3. Tug on the seat belt to make sure it is securely fastened. If the buckle unlatches, repeat this step. If the problem continues, replace the three-point seat belt.
4. Snug the seat belt to your waist.

## **WARNING**

**Before activating the Komfort Latch or the Sliding Komfort Latch, make sure the amount of slack in the shoulder strap is set as described below. Excess slack in the shoulder strap reduces the effectiveness of the seat belt, and increases the risk of injury or death in an accident.**

5. Position the shoulder strap diagonally across your chest with the adjustable D-loop bracket (if equipped). The shoulder strap must be centered on your shoulder and chest, away from your face and neck. See [Fig. 6.11](#). If desired, engage the Komfort Latch or Sliding Komfort Latch as follows.

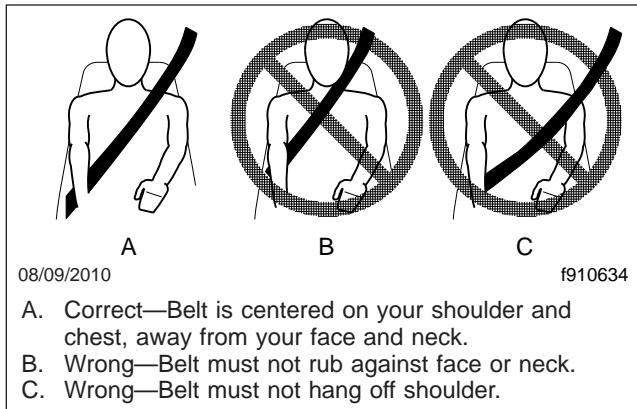
*If equipped with a Sliding Komfort Latch, make sure that the shoulder strap is snug against your chest. Without loosening the shoulder strap, push the Sliding Komfort Latch switch to the "ON" position. See [Fig. 6.9](#). To activate the latch lean forward until you hear a click. This will allow for approximately 1 inch (2.5 cm) of slack be-*



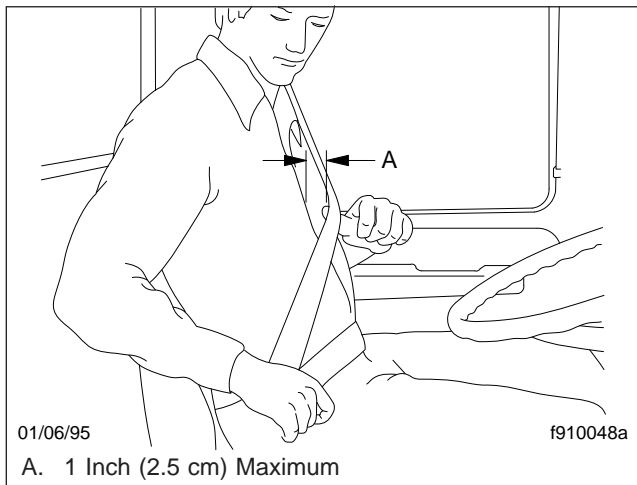
**Fig. 6.10, Three-Point Seat Belt Operation**

tween your chest and the shoulder harness. Once engaged, the latch will allow you to lean forward about 5 inches (13 cm) without having to reset the latch. Leaning forward more than 5 inches (13 cm) will disengage the Sliding Komfort Latch, requiring it to be reset.

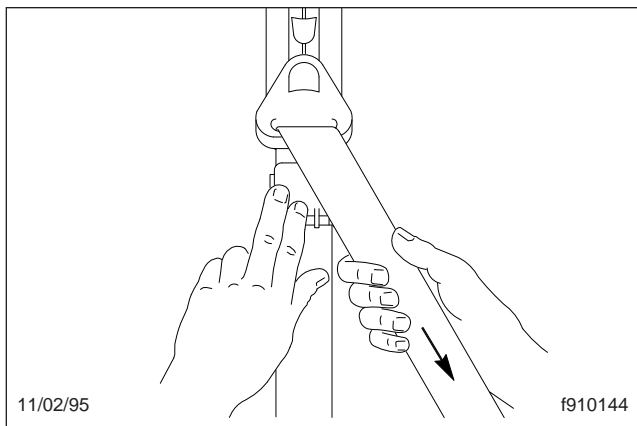
*If equipped with a Komfort Latch, pull on the shoulder strap to lessen the pressure of the strap on your shoulder and chest. Allow no more than 1 inch (2.5 cm) of slack between your chest and the shoulder harness. More slack can significantly reduce the seat belt effectiveness in an accident or a sudden stop. While holding the belt slack, press the Komfort Latch lever up, clamping the seat belt webbing ([Fig. 6.12](#) and [Fig. 6.13](#)).*



**Fig. 6.11, Proper Shoulder Strap Fit**



**Fig. 6.12, Adjusting Shoulder Harness Clearance, Komfort Latch**



**Fig. 6.13, Locking the Komfort Latch**

- Unbuckle the three-point seat belt and release the Komfort Latch or the Sliding Komfort Latch as follows.

*If equipped with a Sliding Komfort Latch, unbuckle the seat belt, then tug on the shoulder belt to release the Sliding Komfort Latch, or press the Sliding Komfort latch to the "OFF" position, then unbuckle the seat belt.*

*If equipped with a Komfort Latch, unbuckle the seat belt, then release the Komfort Latch by giving the shoulder belt a quick tug. If you lean forward against the shoulder belt, the Komfort Latch will automatically release, and will need to be reset.*

**NOTE:** Neither the Komfort Latch nor the Sliding Komfort Latch need to be manually released in an emergency situation. Each will release by itself under rough road or other abnormal conditions. Make sure the three-point seat belt is completely retracted when it is not in use.

### Three-Point Seat Belt

**NOTE:** For vehicles equipped with the Komfort Latch or the Sliding Komfort Latch, see the seat belt operation under the heading "Three-Point Seat Belt With Komfort Latch or Sliding Komfort Latch."

**⚠ WARNING**

**Wear three-point seat belts only as described below. Three-point seat belts are designed to be worn by one person at a time. In case of an accident or sudden stop, personal injury or death could result from misuse.**

**Fasten the seat belts before driving. Fastening a three-point seat belt while driving creates a hazard.**

- Slowly pull the link end of the three-point seat belt out of the retractor and pull it across your lap (from outboard to inboard) far enough to engage the buckle. If the retractor locks too soon, allow the belt to retract slightly, then slowly pull it out again. See [Fig. 6.10](#).
- Fasten the three-point seat belt by pushing the latch into the buckle. Listen for an audible click.

# Seats and Restraints

3. Tug on the seat belt to make sure it is securely fastened. If the buckle unlatches, repeat this step. If the problem continues, replace the three-point seat belt.
4. Snug the seat belt to your waist.
5. Position the shoulder strap diagonally across your chest with the adjustable D-loop bracket (if equipped). The shoulder strap must be centered on your shoulder and chest, away from your face and neck. See [Fig. 6.11](#).
6. To unbuckle the three-point seat belt, press the release button on the buckle.

NOTE: Make sure the three-point seat belt is completely retracted when it is not in use.

## Steering Wheel Air Bag

### Operation

NOTE: Only vehicles with the letters "SRS" molded into the steering wheel center pad are equipped with a steering wheel air bag.

The air bag, when used with seat belts, provides additional protection to the driver in severe frontal collisions. Steering wheel air bags are designed to inflate only in severe frontal collisions. The driver and the passenger should always wear seat belts. The steering wheel air bag will activate during a collision even if the seat belts are not fastened, but the system is designed to provide protection to the occupant only when the seat belts are fastened.

### WARNING

**Keep all heavy objects in the cab secured. Do not place objects on the steering wheel or between you and the steering wheel. Any such objects may cause harm during an accident. Keep your hands on the sides and lower portion of the steering wheel. Failure to follow these instructions may result in death or personal injury.**

For maximum protection in a collision, always be in a normal seated position with your back against the seat back and your head upright. Fasten your seat belt and ensure that it is properly positioned on your body as described under the "Seat Belt Operation" heading. Since the air bag inflates with considerable speed and force, a proper seat position will help keep you a safe distance from the inflating air bag.

## Inspection and Service

### WARNING

**Do not attempt to service or modify the air bag system. Unintentional or improper air bag deployment could cause severe bodily injury or death. Contact an authorized Freightliner service facility for all service and maintenance.**

**The air bag system contains components that use combustible chemicals. Do not cut, drill, braze, solder, weld, strike, or probe the air bag components. Keep all liquids and chemicals away from air bag components.**

**The surface of the deployed air bag may contain small amounts of sodium hydroxide (which is a by-product of the gas generant combustion) and metallic sodium. Sodium hydroxide may be irritating to the skin and eyes. Immediately wash your hands and exposed skin areas with a mild soap and water. Flush your eyes immediately if exposed to sodium hydroxide.**

The operational readiness of the air bag system is indicated by the supplemental restraint system (SRS) indicator on the dash. The SRS indicator illuminates for several seconds when the ignition is turned on, and then it goes off. The indicator will remain on if there is a problem with the air bag system. The vehicle should be serviced if the SRS indicator does not illuminate when the ignition is turned on, or if the SRS indicator remains on.

The air bag module may contain perchlorate material; for information, see [www.dtsc.ca.gov/hazardouswaste/perchlorate](http://www.dtsc.ca.gov/hazardouswaste/perchlorate). Special handling may apply; follow appropriate rules and regulations when disposing of materials.

For all service and maintenance, contact an authorized Freightliner service facility.

# 7

## Climate Control

---

|                                     |     |
|-------------------------------------|-----|
| Cab Climate-Control Panel .....     | 7.1 |
| Sleeper Climate-Control Panel ..... | 7.3 |
| Parked HVAC .....                   | 7.4 |

# Climate Control

## Cab Climate-Control Panel

### Fan Control

The fan switch controls the rate that air is blown through the selected air outlets. It has 8 fan-speed settings, and an OFF position. See [Fig. 7.1](#). To increase the airflow, turn the switch clockwise to a higher number. To decrease the airflow, turn the switch counterclockwise to a lower number. Setting the fan switch at the OFF position disables the cab air conditioning (A/C), and sets the air source to fresh-air mode.

**NOTE:** When the sleeper A/C is running, even though the cab fan switch may be in the OFF position, the cab fan will operate at low speed. This is necessary to protect the evaporator in the cab HVAC system from freezing.

There is a slight delay between the time the engine is started and the blower is operational. It can take an additional 4 seconds for the blower to reach high speed. The blower motor performs a self-test immediately after the engine is started, which causes the delay.

### Air Selection

The air-selection switch allows you to direct the flow of air through the face outlets, the floor outlets, the defrost (windshield) outlets, or a combination of these outlets. There are a total of 9 possible air-selection modes. See [Fig. 7.2](#).

1. **Face Mode:** Directs all airflow through the face outlets in the instrument panel.
2. **Selection between Face Mode and Bi-Level Mode:** Directs 75 percent of the airflow through the face outlets, and 25 percent through the floor outlets.
3. **Bi-Level Mode:** Directs the airflow equally to the face outlets and floor outlets.
4. **Selection between Bi-Level Mode and Floor Mode:** Directs 25 percent of the airflow through the face outlets, and 75 percent through the floor outlets.
5. **Floor Mode:** Directs all airflow through the floor outlets.
6. **Selection between Floor Mode and Floor/Defog Mode:** Directs 75 percent of the airflow through the floor outlets, and 25 percent through the defrost outlets.
7. **Defog Mode:** Directs the airflow equally to the floor outlets and the defrost outlets. The air conditioner automatically turns on in this mode. The recirculation button will not work in this mode.
8. **Selection between Defog Mode and Defrost Mode:** Directs 75 percent of the airflow through the defrost outlets, and 25 percent through the floor outlets. The air conditioner automatically turns on in this mode. The recirculation button will not work in this mode.

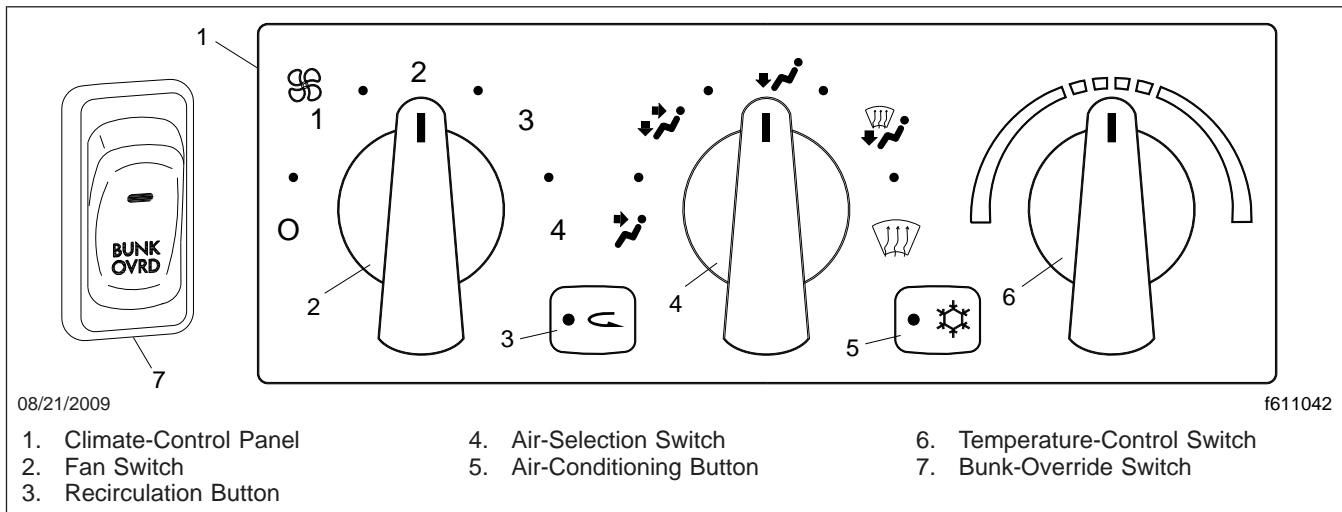
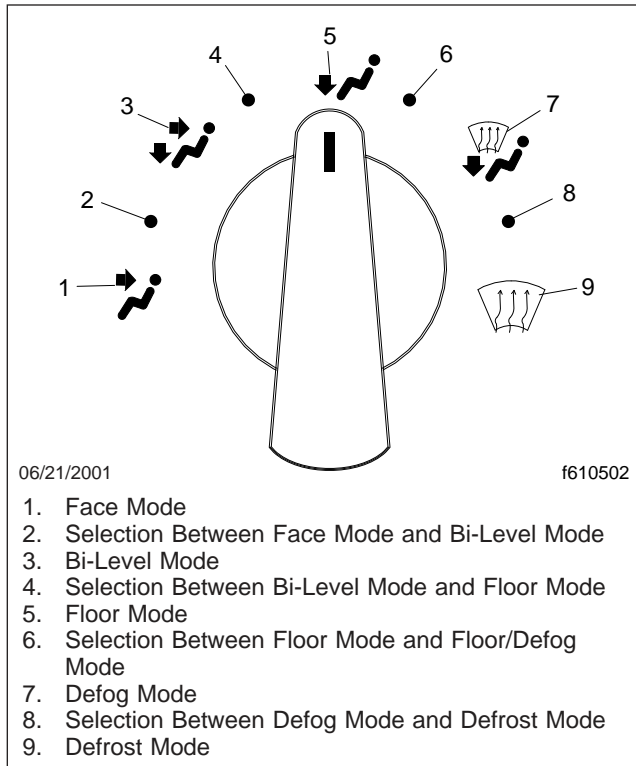


Fig. 7.1, Cab Climate-Control Panel



**Fig. 7.2, Air Selection Modes**

9. **Defrost Mode:** Directs all airflow through the defrost outlets. The air conditioner automatically turns on in this mode. The recirculation button will not work in this mode.

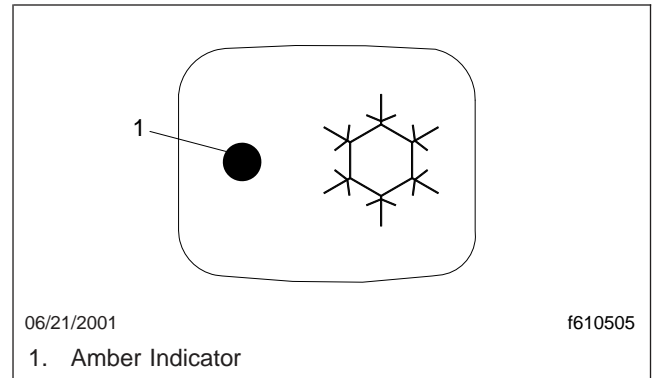
## Temperature Control

The temperature-control switch is used to set the desired temperature. Turn the temperature-control switch clockwise, to the red area, for warm air. Turn the switch counterclockwise, to the blue area, for cool air.

## Air Conditioning

The air conditioner cools and dehumidifies the air inside the cab. Press the air-conditioning button to turn the air conditioner ON and OFF. See [Fig. 7.3](#).

When the A/C is operating, the amber indicator on the air-conditioning button will be illuminated regardless of whether the request for A/C comes from the cab climate-control panel, or the sleeper climate-control panel. When the instrument panel lights are



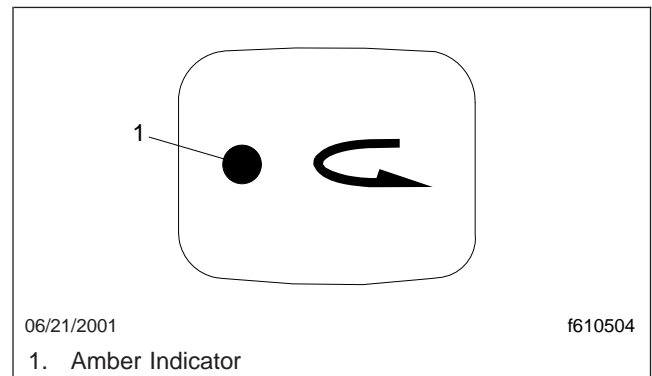
**Fig. 7.3, Air-Conditioning Button**

on, the snowflake indicator on the air-conditioning button will be illuminated.

The A/C will automatically disable when the outside-air temperature is low enough to make air conditioning ineffective, or conditions exist that put the HVAC system into protection mode.

## Recirculation

The recirculation mode limits the amount of outside air entering the cab. It can be used to prevent dusty or smoky air from entering the cab. The recirculation mode can also decrease the time required to cool or heat the cab interior during extreme outside temperature conditions. Press the recirculation button to activate it, or cancel it. When the recirculation mode is ON, the amber indicator on the recirculation button will be illuminated. See [Fig. 7.4](#).



**Fig. 7.4, Recirculation Button**

The recirculation button will not work when the air-selection switch is in one of the following modes:

# Climate Control

- defog mode
- the selection between defog mode and defrost mode
- defrost mode

**NOTE:** To prevent the buildup of fumes or odors, and to prevent oxygen depletion inside the cab, the system switches from full-recirculation mode to partial-recirculation mode after 20 minutes. In extremely dusty or smoky conditions, the partial-recirculation mode can be overridden by pressing the recirculation button twice to obtain full-recirculation mode. This action resets the 20-minute timer.

## Bunk Override

The bunk-override switch allows the driver to remotely set the fan speed and temperature settings for the sleeper. See [Fig. 7.1](#).

When the override switch is not activated, adjusting the climate control in the cab does not affect the sleeper settings. Activating the bunk-override switch causes the cab controls to override the settings on the sleeper HVAC control panel, and the sleeper HVAC will mimic the cab settings. An amber LED in the switch is illuminated when the bunk-override switch is activated.

Adjusting the sleeper HVAC controls at any time, or pressing the switch, will cancel the override mode and the sleeper HVAC will be controlled by the sleeper-control panel. The amber indicator in the bunk-override switch will be off.

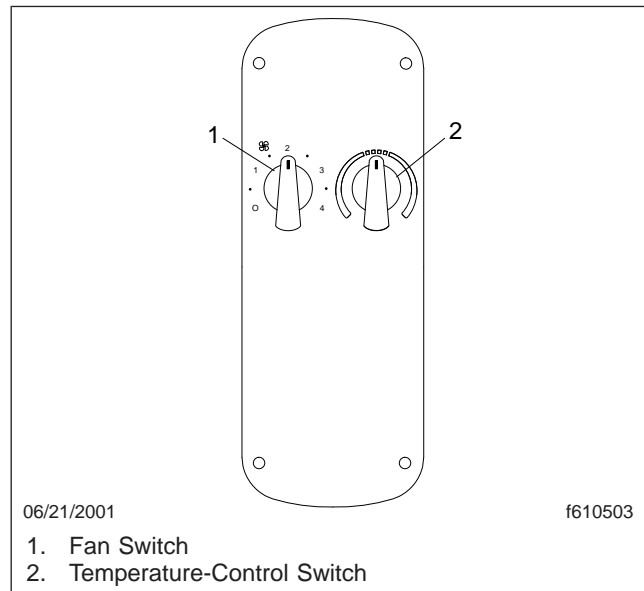
## Sleeper Climate-Control Panel

The sleeper HVAC system features Constant Discharge Temperature Control (CDTC). The CDTC maintains a constant temperature of airflow in the sleeper regardless of outside air temperature, selected fan speed, engine coolant temperature, or engine coolant flow. Once the temperature-control switch is set to the desired temperature, no other adjustments are necessary.

## Fan Control

The fan switch controls the sleeper HVAC system fan speed. It has 8 fan-speed settings, and an OFF position. To increase the airflow, turn the switch clock-

wise to a higher number. To decrease the airflow, turn the switch counterclockwise to a lower number. See [Fig. 7.5](#).



**Fig. 7.5, Sleeper Climate-Control Panel**

**NOTE:** When the cab A/C is on, even though the sleeper fan switch may be in the OFF position, the sleeper fan will operate at low speed. This is necessary to protect the evaporator in the sleeper HVAC system from freezing.

## Temperature Control

The temperature-control switch is used to set the desired temperature in the sleeper. Turn the switch clockwise, to the red area, for warm air. Turn the switch counterclockwise, to the blue area, for cool air. The sleeper A/C automatically turns on when necessary, to maintain the selected temperature. The CDTC system is disabled when the temperature-control switch is in the maximum cool or warm positions.

## Accessory Heaters

Optional accessory heaters are available from the factory in several configurations. Familiarize yourself with the equipment on your specific vehicle, and follow the manufacturer's operating and maintenance instructions.

## WARNING

Do not operate fuel-operated heaters in an area where flammable vapors, including gasoline or diesel fumes, are present, such as at filling stations and tank farms. Turn off a fuel-operated heater and allow it shut down completely before entering an area where flammable gases or liquids are present. Heaters continue to operate for up to three minutes after being turned off.

Failure to observe these precautions could cause an explosion or fire, resulting in serious property damage, and personal injury or death.

## Parked HVAC

The Bergstrom NITE parked HVAC system consists of a compact electrical 3000-BTU air-conditioning system, and a diesel-fired heater unit. It is completely self-contained, and runs on 12-volt deep-cycle batteries located between the frame rails. The parked HVAC batteries are isolated from the vehicle-starting batteries, to prevent the starting batteries from being drawn down during HVAC operation.

The A/C system is designed to maintain cool air in the sleeper interior without having the engine running. However, the parked A/C unit will not cool down a hot sleeper that has been sitting in the sun without the vehicle A/C running. If the interior temperature is higher than desired, start the engine and run the vehicle A/C system until the desired sleeper temperature is achieved. This will help cool the sleeper to a temperature that the parked A/C system can maintain. For optimal operation, the curtain between the cab and the sleeper should be closed when using the Parked HVAC A/C system.

The A/C unit is located under the lower bunk in the sleeper compartment, and intakes air through a grille located on the front panel of the lower bunk. The outlet ducting runs from the left side of the unit to an outlet on the back wall of the sleeper.

The heater unit is located next to the A/C unit. It intakes air through a grille located on the right side of the front panel of the lower bunk. The outlet ducting runs from the back of the unit to a grille on the left side of the front panel of the lower bunk.

## WARNING

Do not operate fuel-operated heaters in an area where flammable vapors, including gasoline or diesel fumes, are present, such as at filling stations and tank farms. Turn off a fuel-operated heater and allow it shut down completely before entering an area where flammable gases or liquids are present. Heaters continue to operate for up to three minutes after being turned off.

Failure to observe these precautions could cause an explosion or fire, resulting in serious property damage, and personal injury or death.

**IMPORTANT:** Blocked vents will hamper the operation of the unit. Keep the area around the air intake grilles clear of objects that may block air flow, or emit objectionable odors into the HVAC system.

## Parked-HVAC Controls

The control panel for the parked HVAC is located on the left side of the rear wall, in the sleeper. It has a temperature-control dial, and a 4-position mode switch. Turn the temperature-control dial to the left for cooling, and to the right for heat. See [Fig. 7.6](#). See [Table 7.1](#) for a description of the mode functions.

After using the system, turn the mode switch to the OFF position, even if the unit is not running, or the batteries may not charge properly.

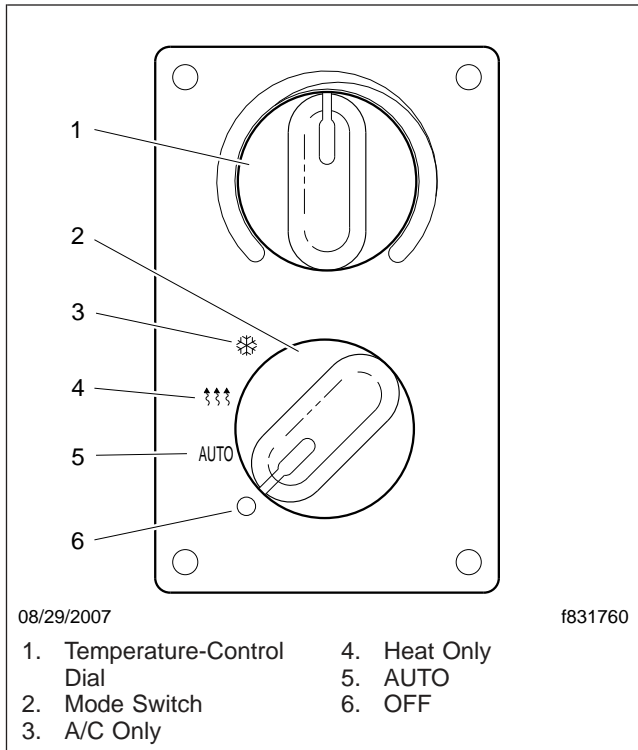
| Parked-HVAC Mode Operation |   |
|----------------------------|---|
| Mode                       | Function  |
| OFF                        | Turns the unit OFF.   |
| AUTO                       | Allows the unit to automatically heat or cool the sleeper, depending on the temperature setting and the sleeper temperature. Adjusts the compressor, heater, and fans to keep temperature constant. |
| Heat Only                  | Allows only the heat portion of the system to run. Adjusts the heater only to keep the temperature constant.  |
| A/C Only                   | Allows only the A/C portion of the system to run. Adjusts compressor and fans only to keep the temperature constant.  |

Table 7.1, Parked-HVAC Mode Operation



# Climate Control

---



**Fig. 7.6, Parked-HVAC Control Panel**

# 8

## Cab Features

---

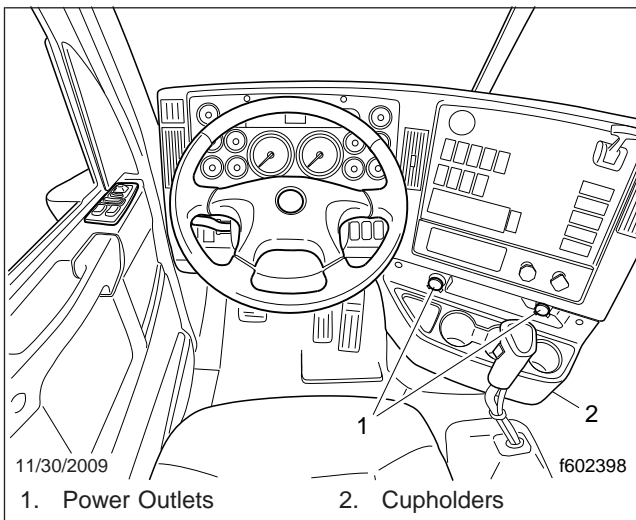
|                         |     |
|-------------------------|-----|
| Cab Amenities .....     | 8.1 |
| Interior Lighting ..... | 8.1 |

# Cab Features

## Cab Amenities

### Center Dash

Three cup holders and a storage tray are molded into the center dash. Power receptacles to supply 12V power for accessories, are located on either side of the cup holders. An optional ashtray/coin holder may be located in the center dash. See [Fig. 8.1](#).



**Fig. 8.1, Cab Amenities**

### Overhead Storage

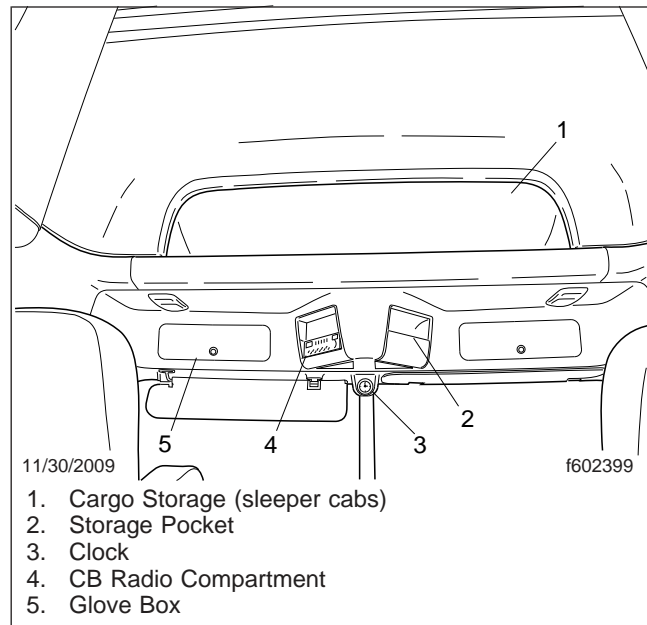
Two glove boxes are located in the overhead console, above the driver and passenger seats. A storage pocket and the CB radio is located in the center of the overhead console. In sleeper cabs, there is an overhead storage compartment above the overhead console. See [Fig. 8.2](#).

## Interior Lighting

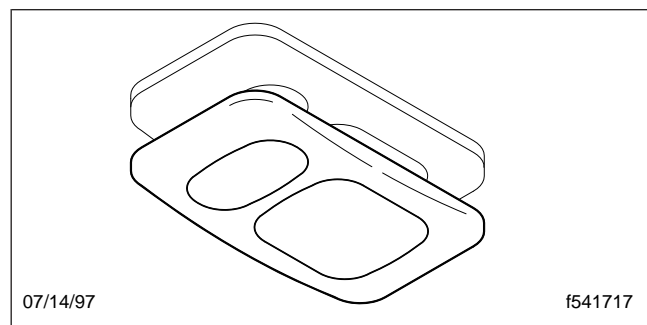
### Dome Lights

Diffuse dome lights are installed on all cabs. See [Fig. 8.3](#). The dome lights are located either on the overhead console, or on the cab roof (if no overhead console is installed). Both dome lights turn on when either the driver's or passenger's door is opened. The dome lights can also be turned on by pressing in on the light lens.

Red map lights are located next to the dome lights in the same fixture. Like the dome lights, the map lights can be turned on by pressing in on the light lens.



**Fig. 8.2, Overhead Console**



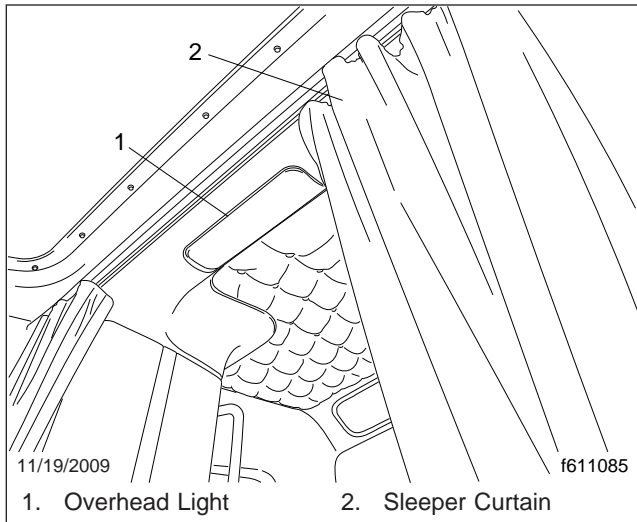
**Fig. 8.3, Dome Light with Red Map Light**

### Overhead Light

The overhead light between the cab and sleeper compartment, is activated with the switch on the dash. See [Fig. 8.4](#).

### Bunk Reading Lights

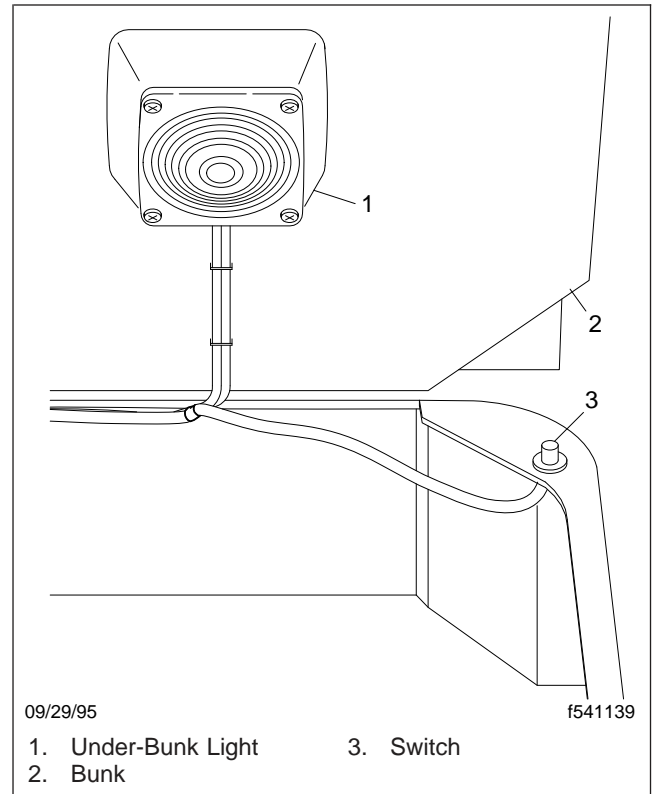
Bunk reading lights are high-intensity swivel lights for use when reading in the bunk. They are located on the bunk control panel for each bunk. To turn on the bunk reading lights, press the rocker switch next to the light on the bunk control panel that holds the light.



**Fig. 8.4, Overhead Light**

## Baggage Compartment Lights

Baggage compartment lights are on all sleeper cabs. One light is located on each side of the cab on the underside of the lower bunk and illuminates the baggage compartment. Both lights turn on when either baggage compartment door is opened. The lights also come on when the lower bunk is raised. See [Fig. 8.5](#).



**Fig. 8.5, Baggage Compartment Light**

# 9

## Engine Starting, Operation, and Shutdown

---

|                        |     |
|------------------------|-----|
| Engine Starting .....  | 9.1 |
| Engine Operation ..... | 9.2 |
| Engine Shutdown .....  | 9.4 |

# Engine Starting, Operation, and Shutdown

## Engine Starting

This engine chapter is to serve as a guide for best practices only. Each make and model engine may have operating characteristics that are unique to that particular engine, and will be documented in the engine manufacturer's literature. Always refer to specific instructions and recommendations from the engine manufacturer.

NOTE: Before starting the engine, read **Chapter 4** for detailed information on how to read the instruments and see **Chapter 5** for detailed information on how to operate the controls. Read the operating instructions in the manufacturer's engine operation manual before starting the engine.

### WARNING

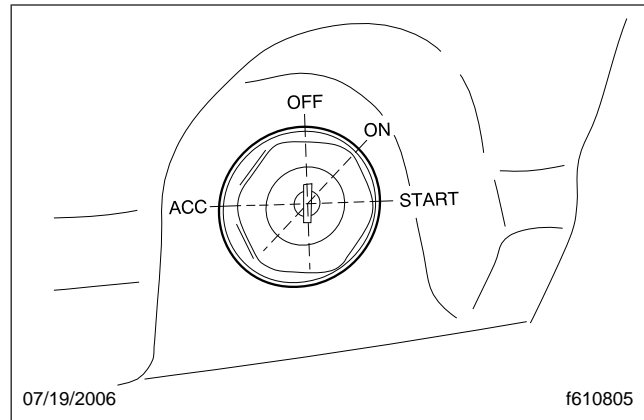
**Never pour fuel or other flammable liquid into the air inlet opening in the air intake in an attempt to start the vehicle. This could result in a flash fire causing serious personal injury or property damage.**

1. Before engine start-up, complete the engine pre-trip and post-trip inspections and maintenance procedures in **Chapter 19** and **Chapter 20**.
2. Set the parking brake.
3. For manual transmissions, place the transmission in neutral and fully depress the clutch pedal. For automatic transmissions, put the transmission in neutral. Do not push the accelerator pedal.

NOTE: Depending on local jurisdictional emissions regulations, vehicles and/or engines that are domiciled outside of the U.S. and Canada may not be equipped with the WAIT TO START or START BLOCKED lamp.

4. Turn the ignition switch to the ON position and allow the gauge sweep to complete. See **Fig. 9.1**. The audible alert will sound for approximately four seconds.

During cold conditions, the WAIT TO START lamp may illuminate. Wait until the lamp goes out before turning the ignition key to START.



**Fig. 9.1, Ignition Switch**

NOTE: The length of time the WAIT TO START lamp remains illuminated depends on the ambient temperature. The lower the ambient temperature, the longer the lamp will be illuminated.

5. Once the gauge sweep has completed, turn the ignition key to the START position. Release the key the moment the engine starts.

### NOTICE

**Do not rev the engine if the oil pressure gauge indicates no oil pressure. Shut down the engine if oil pressure does not build within approximately ten seconds. Check to determine the cause of the problem. Operating the engine with no oil pressure will damage the engine.**

6. It is not necessary to idle the engine before engaging or starting the operation, but load should be applied gradually during the warm-up period until the oil temperature reaches 140°F (60°C).
7. Apply load gradually during the warm-up period.

### NOTICE

**If the oil pressure gauge indicates no oil pressure, shut down the engine within approximately ten seconds to avoid engine damage.**

8. Check the oil pressure gauge for any drop in lubricating oil pressure or mechanical malfunction in the lubricating oil system. Minimum oil pressure at idle is 7 psi (50 kPa).

# Engine Starting, Operation, and Shutdown

## Cold-Weather Starting

See the engine manufacturer's operation manual for starting aids that are approved for specific engines.

## Starting After Extended Shutdown

Before engine start-up, complete the engine pretrip and post-trip inspections and maintenance procedures in [Chapter 19](#) and [Chapter 20](#).

### NOTICE

**Failure to eliminate water-diluted lubricating oil may lead to serious engine damage at startup.**

An engine in storage for an extended period of time (over winter, for example) may accumulate water in the oil pan through normal condensation of moisture on the interanal surfaces of the engine. Oil diluted by water cannot provide adequate bearing protection at start-up. For this reason, change the engine oil and filters after extended storage.

## Engine Operation

### Safety and Environmental Considerations

#### WARNING

**Do not operate the engine in an area where flammable vapors such as gasoline or diesel fumes are present. Shut off the engine when in an area where flammable liquids or gases are being handled. Failure to observe these precautions could result in serious injury or death.**

All Freightliner diesel engines comply with the requirements of the Federal (U.S.) Clean Air Act. Once an engine is placed in service, the responsibility for meeting both state and local regulations is with the owner/operator.

**IMPORTANT:** Depending upon local jurisdictional emissions guidelines, vehicles that are domiciled outside of the U.S. and Canada may not have engines and/or emissions aftertreatment systems that are compliant with EPA10 or GHG14 regulations.

### NOTICE

**It is extremely important that the following guidelines be followed for engines that comply with EPA10 or newer regulations, or damage may occur to the aftertreatment device, and the warranty may be compromised.**

- Use ultralow-sulfur diesel with 15 ppm sulfur content or less.
- Do not use fuel blended with used engine lube oil or kerosene.
- Use only engine lube oil with a sulfated ash level less than 1.0 wt%; currently referred to as CJ-4 oil.

Adequate maintenance of the engine and the diesel-particulate filter are the responsibility of the owner/operator, and are essential to keep the emission levels low. Good operating practices, regular maintenance, and correct adjustments are factors that will help to stay within the regulations.

The driver should be familiar with the vehicle warning system in order to bring the vehicle to a safe stop if the engine malfunctions. If the driver doesn't understand how the warning system works, an engine shutdown could occur, causing a safety hazard. See [Chapter 10](#) for information.

## Engine Break-In

Each engine must pass a full-load operating test on a dynamometer before shipment, thereby eliminating the need for a break-in. Before running the engine for the first time, follow the instructions in the engine manufacturer's operation manual specific to your engine.

## Normal Operation

#### WARNING

**Do not operate the engine in an area where flammable vapors such as gasoline or diesel fumes are present. Shut off the engine when in an area where flammable liquids or gases are being handled. Failure to observe these precautions could result in serious injury or death.**

All engines have an operating range specific to that engine in which the engine performs most efficiently.

# Engine Starting, Operation, and Shutdown

---

The operating range extends from maximum torque rpm at the low end to engine rated speed at the high end. Most engines deliver best fuel economy when operated in the low- and mid-speed segments of the efficiency range and produce maximum horsepower at rated speed, which is also the recommended maximum speed of the engine. For specifics for any engine refer to the engine manufacturer's operation manual.

Prolonged idling of engines is not recommended, and is illegal in some states. The belief that idling a diesel engine causes no engine damage is wrong. Idling produces sulfuric acid, that is absorbed by the lubricating oil, and eats into bearings, rings, valve stems, and engine surfaces. If you must idle the engine for cab heat or cooling, the high idle function of the cruise control switches should be used. An idle speed of 900 rpm should be enough to provide cab heat in above freezing ambient temperatures.

If the engine is programmed with the idle shutdown timer, ninety seconds before the preset shutdown time, the CHECK ENGINE light will begin to flash at a rapid rate. If the position of the clutch pedal or service brake changes during this final ninety seconds (CHECK ENGINE lamp flashing) the idle shutdown timer will be disabled until reset.

## Cold-Weather Operation

Satisfactory performance of a diesel engine operating in low ambient temperatures requires modification of the engine, surrounding equipment, operating practices, and maintenance procedures. The lower the temperature, the greater the amount of modification required. For service products approved for use in cold weather for your engine, see the engine manufacturer's engine operation manual, supplied in the vehicle documentation package.

If satisfactory engine temperature is not maintained, maintenance costs will increase due to greater engine wear. If the engine coolant temperature becomes too low, raw fuel will wash the lubricating oil off the cylinder walls and dilute the crankcase oil, causing all moving parts of the engine to suffer from poor lubrication.

If the engine is in good mechanical condition and the precautions necessary for cold-weather operation are taken, ordinary cold weather will not cause difficulty in starting, or loss of efficiency.

The following points are important to observe when operating in cold weather:

- Check for cracks in the batteries, for corrosion of the terminals, and for tightness of the cable clamps at the terminals.
- Charge the batteries to full capacity. Replace any battery that is damaged.
- If so equipped, turn off the load disconnect switch after the engine is shut down, to prevent battery discharge.
- Have the alternator output checked at an authorized service provider.
- Check the condition and tension of the drive belts.
- Refer to the engine manufacturer's engine operation manual for recommended heaters, low-viscosity lubricating oils, wintergrade fuels, and approved coolants.

---

## NOTICE

---

**For Detroit engines (EPA07 and newer), use of a winterfront is not recommended, as it can cause false fault codes with the engine and aftertreatment system, and possible emission component failures.**

If using a winterfront, leave at least 25% of the grille opening exposed in sectioned stripes that run perpendicular to the charge-air-cooler tube-flow direction. This assures even cooling across each tube, and reduces header-to-tube stress, and possible chance of component failure. For engine-specific guidelines, see below:

*Cummins and Mercedes-Benz engines:* A winterfront may be used to improve cab heating while idling, and only when the ambient temperature remains below 10°F (-12°C).

*Detroit engines (EPA07 and newer):* Use of a winterfront is not recommended. Using a winterfront can cause excessive fan run time, increased fuel consumption, and failure of the DEF system heaters to operate correctly, resulting in fault codes, poor performance, and power reduction. A winterfront should only be used temporarily in the following situations:

- to improve cab heating while idling in an extremely cold ambient temperature;



# Engine Starting, Operation, and Shutdown

---

- when the ambient temperature remains below -22°F (-30°C) and the engine is unable to maintain a running coolant temperature of 175°F (80°C) during normal over-the-road operation.

## Engine Shutdown

1. With the vehicle stopped, apply the parking brakes and place the transmission in neutral.

---

### NOTICE

---

**Idle the engine one to two minutes before shutting it down. After hard operation, shutting down the engine without idling may cause damage to the turbocharger.**

2. Allow the engine to idle one to two minutes before shutting it down. This allows the lubricating oil and the coolant to carry heat away from the combustion chambers, bearings, shafts, and seals. The extreme heat may cause bearings to seize or oil seals to leak.

**IMPORTANT:** Bearings and seals in the turbocharger are subjected to the high heat of combustion exhaust gases. While the engine is running, this heat is carried away by oil circulation, but if the engine is stopped suddenly, the turbocharger temperature may rise as much as 115°F (46°C).

---

### NOTICE

---

**Except in an emergency, do not shut down the engine when the coolant temperature is above 194°F (90°C). To do so could damage the engine.**

3. Turn off the ignition switch and shut down the engine.

# 10

## Optional Engine Systems

---

|  |      |
|--|------|
| Engine Protection—Warning and Shutdown ..... | 10.1 |
| Engine Idle Limiting .....                   | 10.1 |
| Cruise Control .....                         | 10.2 |
| Engine Brakes .....                          | 10.3 |
| Power Takeoff (PTO) Governor .....           | 10.5 |
| Optimized Idle® .....                        | 10.5 |

# Optional Engine Systems

## Engine Protection—Warning and Shutdown

### WARNING

When the red STOP engine or engine protection light illuminates, most engines are programmed to shut down automatically within 30 seconds. The driver must immediately move the vehicle to a safe location at the side of the road to prevent causing a hazardous situation that could cause bodily injury, property damage, or severe damage to the engine.

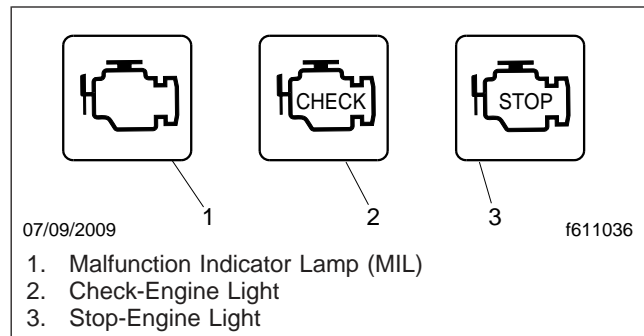
The driver should be familiar with the vehicle warning system, in order to bring the vehicle to a safe stop if the engine malfunctions. If the driver doesn't understand how the warning system works, an engine shutdown could occur, causing a safety hazard.

If the engine coolant temperature, the coolant level, the engine oil pressure, or exhaust aftertreatment system (on some engines, the engine oil temperature, or the intake air temperature) reach preset levels, the engine will begin a warning and shutdown process. See the engine manufacturer's operation manual for specific details for your vehicle. See [Chapter 11](#) in this manual, for the warning and shutdown modes associated with the exhaust aftertreatment system.

Electronic engine protection is programable as an option, and can be specified as the following; DERATE, and SHUTDOWN mode (factory default), WARNING mode, or OFF mode.

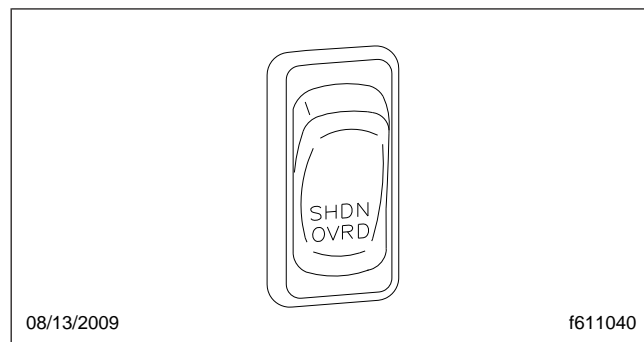
In the DERATE and SHUTDOWN mode, the red stop-engine light will illuminate when the problem is serious enough to reduce the power or speed. The engine power will ramp down, then shut down, if the problem continues. The driver has 30 seconds after the stop-engine light illuminates, to move the vehicle safely off the road. If the vehicle cannot be moved to a safe location within that time, the engine can be restarted by turning the ignition switch to the OFF position for at least 5 seconds, then back ON. This action can be repeated until the vehicle is safely off the road. See [Fig. 10.1](#).

Some vehicles may have a shutdown-override switch, which may be used to override the shutdown sequence. This switch resets the shutdown timer, restoring power to the the level before the derate



**Fig. 10.1, Engine Warning Lights**

was initiated. The switch must be pressed again after 5 seconds to obtain a subsequent override. It can be used to move the vehicle to a safe stopping area. Do not operate the vehicle until the problem has been corrected. See [Fig. 10.2](#).



**Fig. 10.2, Shutdown Override Switch**

If the engine protection parameters are set to WARNING, it warns the driver; the amber, check-engine light will flash, and a buzzer will sound. The engine electronics log the event for diagnostic purposes. The check-engine light will go out if the problem stops.

If the engine protection parameters are set to OFF mode, the individual sensor indicator lights will illuminate if a problem exists, but no shutdown action will be started, and the event will not be recorded.

## Engine Idle Limiting

### Idle Shutdown Timer

This feature is an optional 1-to-100 minute idle shutdown system. Its purpose is to conserve fuel by eliminating excessive idling, and allowing a turbo-charger cool-down period. To activate the shutdown,

the transmission must be in neutral with the vehicle parking brakes set and the engine in idle or fast-idle mode.

## California Engine Idle Limiting

In order to meet the California Air Resources Board (CARB) engine idle limiting standard, an engine idle shutdown feature has been included in engine control strategy. When the CARB engine idle limiting feature is enabled, the engine will generally shut down after five minutes of continuous idling when the transmission is in neutral or park, and the parking brake is set, or after fifteen minutes when the transmission is in neutral or park, and the parking brake is not set.

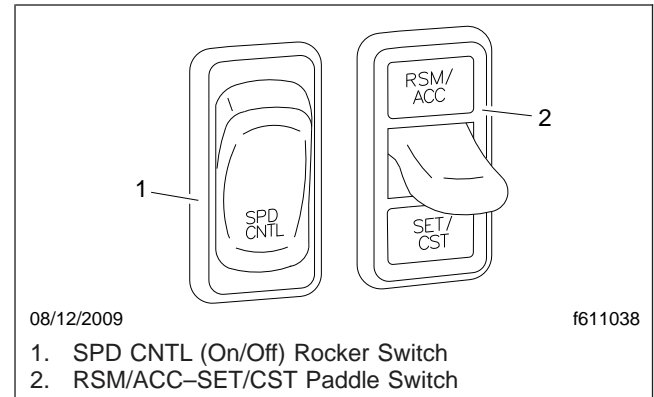
Activating or momentarily changing the position of the service-brake pedal, the clutch pedal, stop-engine override switch, the accelerator pedal, or parking brake, during the final 30 seconds before a shutdown would otherwise occur, will prevent the engine from shutting down, and will reset the shutdown timer. After an automatic shutdown, the engine may be restarted and operated normally.

The automatic shutdown feature is generally disabled on engines certified by the U.S. EPA for use outside California, but is required to be enabled for all California-certified engines (with the exception of engines used in specific vehicle types that the state of California has determined to be exempt from the idle shutdown requirement). Owners that wish to have the shutdown feature disabled should consult with California authorities to determine if their vehicle qualifies for the exemption.

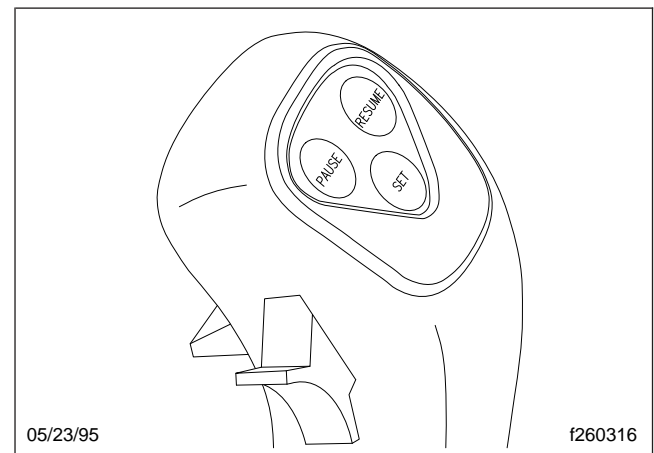
## Cruise Control

**IMPORTANT:** For vehicles with Eaton VORAD Collision Warning System (CWS) with Smart-Cruise, see the "Collision Warning System" in [Chapter 4](#) of this manual, before operating cruise control.

The cruise control is activated by the SPD CNTL (on/off) and RSM/ACC–SET/CST switches on the dash ([Fig. 10.3](#)), or by optional PAUSE, RESUME, and SET buttons on the transmission shift knob ([Fig. 10.4](#)). The minimum speed at which cruise control can be used is 30 mph (48 km/h). The minimum and maximum speed cruise control set limits can be programmed, by authorized personnel, into the engine electronics.



**Fig. 10.3, Cruise Control Switches, Dash-Mounted**



**Fig. 10.4, Cruise Control, Transmission Shift Knob Buttons**

### **WARNING**

Do not use the cruise control system when driving conditions do not permit maintaining a constant speed, such as in heavy traffic or on roads that are winding, icy, snow-covered, slippery, or roads with a loose driving surface. Failure to follow this precaution could cause a collision or loss of vehicle control, possibly resulting in personal injury or property damage.

### **NOTICE**

Do not attempt to shift gears without using the clutch pedal when the cruise control is engaged. Failure to follow this precaution will result in a temporarily uncontrolled increase in engine

# Optional Engine Systems

speed; transmission damage and gear stripping could result.

1. To cruise at a particular speed:
  - 1.1 Press the upper half of the SPD CNTL (on/off) rocker switch on the instrument control panel.
  - 1.2 Hold the throttle down until the speedometer reaches the desired speed.
  - 1.3 Momentarily flip the RSM/ACC–SET/CST paddle switch on the instrument control panel down to SET/CST.  
*or*—Push the SET button on the transmission shift knob.
2. To disengage the cruise control:

Depress the brake pedal or clutch pedal.

*or*—Press the lower half of the SPD CNTL rocker switch on the instrument control panel.

*or*—Push the PAUSE button on the transmission shift knob.
3. To resume a preselected cruise speed:

Momentarily flip the RSM/ACC–SET/CST paddle switch on the instrument control panel to RSM/ACC.

*or*—Push the RESUME button on the transmission shift knob. Cruise will return to the last speed selected.

If the SPD CNTL rocker switch on the instrument control panel is off, turn it on.

NOTE: The resume vehicle speed memory is not maintained if the ignition is shut off.

4. To adjust cruise speed up or down:

Hold the paddle switch on the instrument control panel at RSM/ACC to accelerate, or at SET/CST to decelerate, until the desired speed is reached.

*or*—Press the SET button on the transmission shift knob to accelerate, or the RESUME button to decelerate, until the desired speed is reached.

## Engine Brakes

### WARNING

To avoid injury from loss of vehicle control, do not activate the engine brake system under the following conditions:

- on wet or slippery pavement, unless the vehicle is equipped with antilock braking system (ABS) and you have had prior experience driving under these conditions;
- when driving without a trailer or pulling an empty trailer;
- if the tractor drive wheels begin to lock, or there is fishtail motion after the engine brake is activated.

Each engine manufacturer uses a specific engine brake for their engine. Regardless of the manufacturer, the engine brake is operated with the principles outlined in this chapter. Refer to the engine manufacturer's operation manual for details of their particular engine brake product.

Whenever vehicle braking is required on good road conditions, the engine brake may be used in conjunction with the service brakes. There is no time limit for operation of the engine brake. However, an engine brake does not provide the precise control available from the service brakes, and is not a substitute for a service braking system.

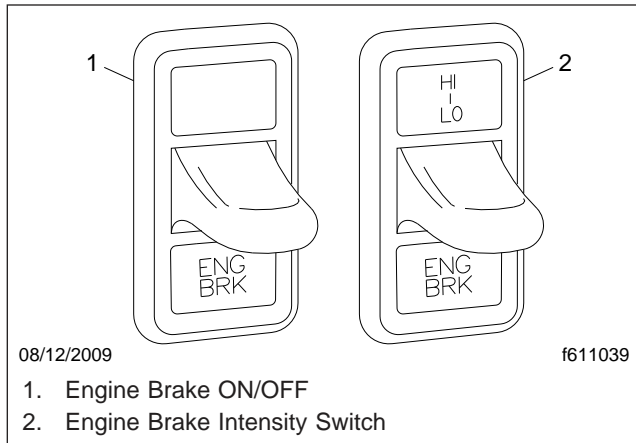
### WARNING

**Usage of the engine brake as the primary braking system can cause unpredictable stopping distances, that could result in personal injury or property damage. Service brakes are the primary vehicle braking system.**

There are two switches that control the engine brake.

- The dash mounted ON/OFF switch (ENG BRK), is used to turn the engine brake ON and OFF. See [Fig. 10.5](#).
- The HI/MED/LO (in some cases HI/LO) engine brake level switch on the dash, controls the amount of engine braking.

Since the engine brake is most effective at rated engine speed, gear selection is very important. Gearing



**Fig. 10.5, Engine Brake Switches**

down the vehicle, within the limits of the rated engine speed, makes the engine brake more effective. Recommended engine braking speed is above 1800 rpm and below the rated speed.

## **⚠ WARNING**

**The engine brake must be disengaged when shifting gears using the clutch pedal. If the engine brake is engaged when the transmission is in neutral, the braking power of the engine brake can stall the engine, which could result in loss of vehicle control, possibly causing personal injury and property damage.**

## **NOTICE**

**Do not allow the engine to exceed 2500 rpm. Serious engine damage could result.**

"Control speed" is the speed at which the engine brake performs 100 percent of the required downhill braking, resulting in a constant speed of descent. The control speed varies, depending on vehicle weight and the downhill grade.

For faster descent, select a higher gear than that used for control speed. Service brakes must then be used intermittently to prevent engine overspeed and to maintain desired vehicle speed.

A driver may descend slower than control speed by selecting a lower gear, being careful not to overspeed the engine. Occasional deactivation of the engine brake may be necessary to maintain the designated road speed under these conditions.

Below a set engine temperature when the engine is cold, the brake may be disabled depending on the brake type.

## Engine Brake Operation

To activate the engine brake after the engine is warmed up and the vehicle is in motion:

- Remove your feet from both the clutch and throttle pedals. Press the dash-mounted ENG BRK switch to toggle the engine brake ON. See [Fig. 10.4](#).

The engine brake will engage at the rate last set on the brake intensity switch.

- Move the intensity switch to the desired intensity. Depending on engine model, LO will provide 1/3 or 1/2 of the full braking capacity of the engine. HI will provide maximum engine braking.

Use the dash-mounted switch set at the LO position when driving on flat, open stretches of road. If the service brakes are still required to slow down on a grade, switch to a higher setting on the dash switch, until there is no need for the service brakes. Grade descent speed should be such that the service brakes are used infrequently and that they remain cool, thus retaining their effectiveness.

- For maximum retarding, maintain the top governed speed of the engine through the appropriate selection of gears. When shifting gears, the engine brake will disengage when the clutch pedal is depressed, then engage when the clutch pedal is released.
- To cancel the engine brake application, toggle the ENG BRK switch OFF.

If the engine is equipped with both cruise control and an engine brake, the engine brake can operate automatically while in cruise control mode. If the cruise control/engine brake function is turned on in the DDEC VI system programming, the engine brake will come on "low" when the set road speed increases a few miles-per-hour (kilometers-per-hour) above the cruise set speed. The maximum amount of braking (low, medium, high) is selected with the dash switches. When the vehicle returns to the set cruise speed, the engine brake will turn off.

# Optional Engine Systems

---

The engine brake will only operate when the accelerator pedal is fully released. Disengaging the clutch will prevent the engine brake from operating.

Vehicles equipped with antilock braking systems (ABS) have the ability to turn the engine brake off if a wheel-slip condition is detected. The engine brake will automatically turn itself back on once the wheel slip is no longer detected. The DDEC VI system will deactivate the engine brake system when the engine speed falls below 1000 rpm or when the vehicle slows down to a preset speed, depending on DDEC programming. This prevents stalling the engine.

## Power Takeoff (PTO) Governor

Front Engine Power Take Offs (PTO) are devices used to tap into engine power to run auxiliary devices. Common uses are vehicles with hydraulic pumps which power additional equipment. The following instructions are general guidelines for operating a PTO.

1. Set the parking brake. Shift the transmission to neutral.
2. Press the dash PTO switch. Release the switch when the light begins to blink.  
When the light comes on steadily, the PTO is engaged and ready to operate. In stationary mode, the vehicle must remain in neutral with the parking brake set.
3. To activate the mobile mode, shift from neutral to reverse, 1st, or 2nd gear. The clutch will open and the PTO will disengage for a moment.
4. Touch the throttle pedal to close the clutch and engage the PTO in mobile mode. The PTO may be operated with the transmission in the following gears only: R-N-1-2.

**NOTE:** Do not attempt to change gears while the vehicle is moving. The transmission will ignore the request.

5. To end the mobile mode, bring the vehicle to a stop. The clutch will open and shut off power to the PTO.
6. To resume stationary mode, shift to neutral. The PTO will engage.
7. To end stationary mode, press the dash switch. When the light in the switch goes out, power to the PTO is shut off. Shut down the engine.

## Optimized Idle®

The optimized idle option on Detroit Diesel engines is a system that automatically stops and restarts the engine to accomplish the following:

- Keep the engine oil temperature between 60 and 104°F (16 to 40°C)
- Keep the battery charged
- Keep the cab or sleeper at a constant, desired temperature (if equipped with a thermostat)

The benefits of the system include reduced engine idle time, fuel savings, reduction of exhaust emissions and noise, increased starter and engine life, and less chance of dead batteries due to electrical loads.

Optimized Idle operates in two modes; the engine mode or the thermostat mode. The engine mode keeps the battery charged and the engine oil temperature within factory set limits. The thermostat mode is the same as the engine mode, but also keeps the cab and sleeper at a constant preset temperature.

The engine mode is always activated when the system is operated. The thermostat mode is activated when the thermostat is turned on.

The thermostat mode controls the set point, which is the desired temperature of the cab and sleeper, and the comfort zone, which is the number of degrees from the set point before the engine needs to heat or cool the cab. There are three comfort zones: 4°F (2°C), 7°F (4°C), or 10°F (6°C).

Vehicles equipped with Optimized Idle have a label on the dash, and a telltale lens in the dash message center. See [Fig. 10.6](#) for the dash label detail. See [Chapter 4](#) for the appropriate dash message center. If equipped with the thermostat mode, a thermostat is located in the sleeper, above the bunk. See [Fig. 10.7](#).

The thermostat consists of an LCD readout and four buttons.

The display normally shows the temperature of the sleeper, but changes accordingly as the buttons are pressed.

The button functions are as follows:

- Up Button: increases the set point and comfort zone.

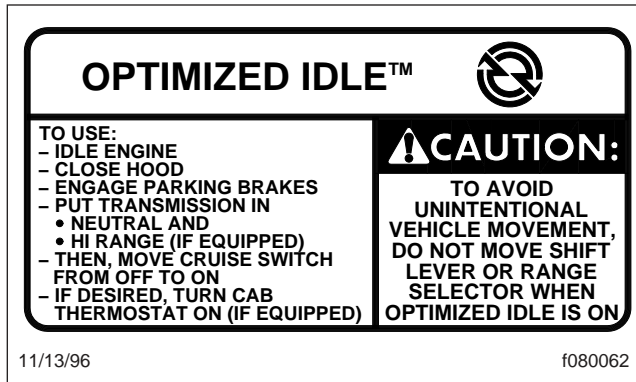


Fig. 10.6, Optimized Idle Dash Label

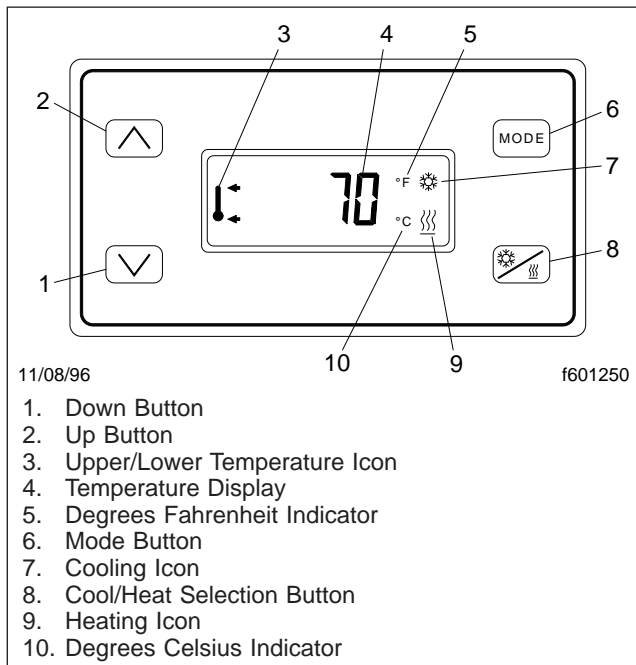


Fig. 10.7, Optimized Idle Thermostat

- Down Button: decreases the set point and comfort zone.
- Cool/Heat Button: detects either cooling or heating operation.
- Mode Button: scrolls through the various functions. It can also be used to set desired temperature values.

1. Activate Optimized Idle (engine mode).
  - 1.1 Set the parking brake.

- 1.2 If it is tilted, close and secure the hood.
- 1.3 Start the engine and let it idle.
- 1.4 Put the transmission in neutral.
- 1.5 Turn on the cruise control.

The dash light will begin blinking, indicating that Optimized Idle is active. The system is now in the engine mode and after an initial phase, in which the idle speeds up to 1000 or 1500 rpm (depending on the outside temperature), the engine will stop and start automatically to keep the battery charged and the engine oil warm. The dash light stays on and shines steadily at this point.

**IMPORTANT:** The cruise control must be turned on *after* the engine is idling. If it was previously turned on, turn off the cruise control, then turn it on again.

2. Activate the thermostat mode (if so equipped).

**NOTE:** When the system is in the thermostat mode, it is also in the engine mode. It will continue to operate in the engine mode even if the thermostat mode is turned off.

- 2.1 With the system in the engine mode, set the cab and sleeper heater or air conditioner controls to the highest setting.
- 2.2 Turn on the thermostat by touching any of the four buttons. See [Fig. 10.7](#).

The display will flash the current sleeper temperature and the previous mode (cooling or heating) selected. If the cab needs to be cooled or heated, the cool/heat icon will flash.

- 2.3 Choose either cool or heat by pressing the *Cool/Heat* button. Make sure the selection matches that of the cab controls.

**IMPORTANT:** If the heat or cool selection of the thermostat does not match that of the cab, the system will idle and cycle excessively.

- 2.4 Select Fahrenheit or Celsius by pressing and holding the *Mode* button until either the "F" or "C" is displayed.



# Optional Engine Systems

---

- 2.5 Select the temperature set point by pressing either the *Up* button or the *Down* button, as applicable. Holding the button will cause the display to count up or down rapidly. When the desired set point is displayed, release the button. The set point is stored in memory.
- 2.6 Select the temperature comfort zone by pressing the *Mode* button until the upper and lower temperature limit icon is displayed. Then use the *Up* or *Down* button to select one of the three comfort zones of 4°F (2°C), 7°F (4°C), or 10°F (6°C).
3. To change the display to either Fahrenheit or Celsius, press the *Mode* button until only the *F°* or *C°* icon is flashing. Press the *Up* or *Down* button to change to the desired value. The main display will appear five seconds after the button is released.
4. To deactivate the thermostat mode and return to just the engine mode, press the *Mode* button and hold it for three seconds.
5. To shut down Optimized Idle completely, either turn off the ignition or use the drive away feature.  
The drive away feature allows the use of all the engine features. Use the drive away feature as follows:
  - 5.1 *If the engine is running:* Release the parking brakes or put the transmission in gear.  
*If the engine is not running:* Start the engine. Release the parking brakes or put the transmission into gear.
  - 5.2 Let the engine return to base idle. The active light will turn off. Optimized Idle is now disabled and all the engine features are available.

# 11

## Emissions and Fuel Efficiency

---

|   |      |
|---|------|
| Greenhouse Gas Emissions and Fuel Consumption Standards ..... | 11.1 |
| EPA-Regulated Emissions Aftertreatment Systems .....          | 11.1 |
| Diesel Exhaust Fluid and Tank .....                           | 11.3 |

# Emissions and Fuel Efficiency

---

## Greenhouse Gas Emissions and Fuel Consumption Standards

Vehicles and/or engines manufactured after December 31, 2006 and domiciled in the U.S. or Canada are required to meet all EPA and NHTSA regulations effective as of the vehicle build date. Engines manufactured between January 1, 2010 and December 31, 2012 meet EPA10 requirements. Engines manufactured from January 1, 2013 meet NHTSA and EPA 2014 fuel efficiency and greenhouse gas emission standards (GHG14) requirements.

Model year 2013 and later vehicles meet additional requirements as specified by GHG14 requirements. These vehicles are equipped with components that increase fuel efficiency and reduce GHG emissions. Components may include, but are not limited to, low-rolling resistance tires; aerodynamic devices such as hood, cab/sleeper extenders, and fuel tank fairings; vehicle speed limiter; and idle shutdown timer. If replacement of any drag-reducing component is required, the replacement component must meet or exceed the drag reduction performance of the originally installed component in order to maintain compliance with GHG14 requirements.

## EPA-Regulated Emissions Aftertreatment Systems

IMPORTANT: Depending on local jurisdictional guidelines, vehicles that are domiciled outside of the U.S. and Canada may not have emissions aftertreatment systems (ATS) that are compliant with EPA regulations.

### NOTICE

It is extremely important that the following guidelines be followed for engines that comply with EPA10 and newer regulations, or damage may occur to the aftertreatment device, and the warranty may be compromised.

- Use ultralow-sulfur diesel with 15 ppm sulfur content or less.
- Do not use fuel blended with used engine lube oil or kerosene.

- Use only engine lube oil with a sulfated ash level less than 1.0 wt%; currently referred to as CJ-4 oil.

IMPORTANT: Using non-specification fuels or oils can lead to shortened diesel particulate filter (DPF) cleaning or replacement intervals. For example, using CJ-4+ oil with 1.3% sulfated ash (30% more ash content) may result in the need for DPF cleaning or replacement 20 to 30% sooner than would normally be required.

IMPORTANT: See the engine manufacturer's operation manual for complete details and operation of the aftertreatment system (ATS).

The EPA mandates that all engines built after December 31, 2009 must reduce the level of emissions exhausted by the engine to the following levels:

- Nitrogen Oxides (NOx) – 0.2 g/bhp-hr
- Particulate Matter (PM) – .01 g/bhp-hr

To meet EPA guidelines, engines that are compliant with EPA10 and newer regulations use technology known as selective catalytic reduction (SCR) in the exhaust aftertreatment system (ATS). The ATS includes an aftertreatment device (ATD), with the addition of SCR to reduce NOx downstream of the engine. The SCR process requires the introduction of diesel exhaust fluid (DEF) into the exhaust stream.

After exhaust gases leave the engine, they flow into the ATS. First they flow into a two-part ATD, comprised of a diesel oxidation catalyst (DOC) and a diesel particulate filter (DPF). The DPF traps soot particles, then exhaust heat converts the soot to ash, in a process called regeneration (regen). After exhaust gases leave the DPF, a controlled quantity of diesel exhaust fluid (DEF) is injected into the exhaust stream. In the presence of heat, DEF is converted to ammonia gas, which reacts with NOx in the selective catalyst chamber to yield nitrogen and water vapor, which exit through the tailpipe.

## Regeneration

The harder an engine works, the better it disposes of soot. If the exhaust temperature is high enough, a process called **passive regeneration** (regen) occurs as the vehicle is driven normally. However, if the engine isn't running hot enough, the electronic controls may initiate an **active regen**, whereby extra fuel is injected into the exhaust stream to superheat and

reduce the soot trapped in the DPF to ash. Active regen happens only when the vehicle is moving above a certain speed, determined by the engine manufacturer. See your engine operation manual for complete details. Both active and passive regen happen automatically, without driver input.

## WARNING

**Active regeneration can occur automatically anytime the vehicle is moving. The exhaust gas temperature could reach 1500°F (800°C), which is hot enough to cause a fire, heat damage to objects or materials, or personal injury to persons near the exhaust outlet. The exhaust temperature can remain high even after the vehicle has stopped. When stopping the vehicle shortly after an automatic regen, ensure the exhaust outlets are directed away from structures, trees, vegetation, flammable materials, and anything else that may be damaged or injured by exposure to high heat.**

**See *Regen Switches*, below, for instructions on preventing automatic regen if necessary.**

When operating conditions do not allow for ATD filter cleaning by active or passive regen, the vehicle may require a driver-activated **parked regen**. When this occurs, the DPF lamp illuminates, indicating that a regen is required. The driver must either bring the vehicle up to highway speed to increase the load (thus starting an active regen), or park the vehicle and initiate a parked regen. See *Regen Switches*, below, for instructions on initiating a parked regen.

## Regen Switches

The regen request switch, located on the dash, is used to initiate a parked regen. See [Fig. 11.1](#). To access the regen request switch, lift the guard and press the yellow button.

Some vehicles may be equipped with a regen request/inhibit switch. See [Fig. 11.2](#). To stop a regen in progress or prevent the start of a regen, press the lower half of the switch. Regen is then delayed until the switch is no longer active.

**NOTE:** The regen switch can initiate a parked regen only when the DPF lamp is illuminated.

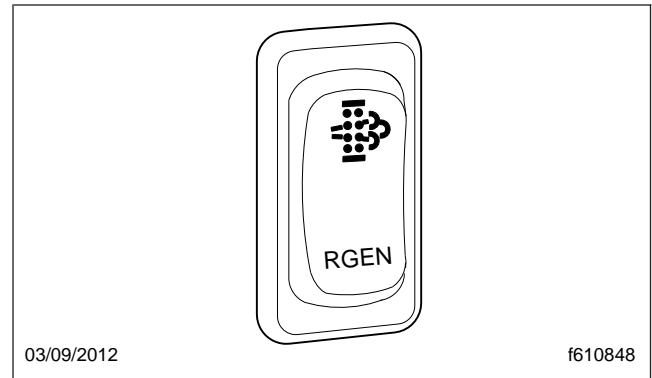


Fig. 11.1, Regen Request Switch

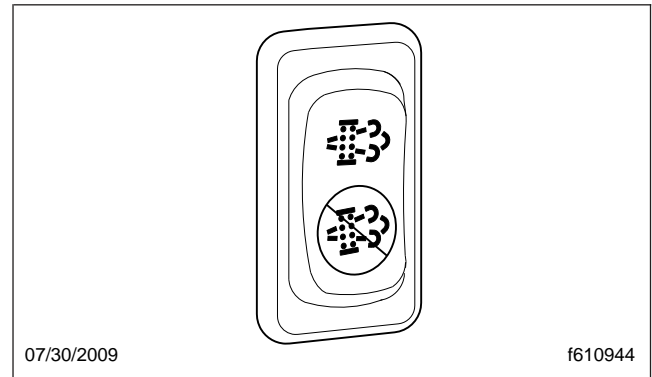


Fig. 11.2, Regen Request/Inhibit Switch

## WARNING

**During parked regen, exhaust temperatures are very high and could cause a fire, heat damage to objects or materials, or personal injury to persons near the exhaust outlet.**

**Before initiating a parked regeneration, make certain the exhaust outlets are directed away from structures, trees, vegetation, flammable materials, and anything else that may be damaged or injured by prolonged exposure to high heat.**

To initiate a parked regen, perform the following steps.

1. Park the vehicle away from all flammable materials, put the transmission in neutral, and set the parking brake.
2. Start and warm the engine until the coolant temperature is at least 150°F (66°C).

# Emissions and Fuel Efficiency

---

3. Lift the regen request switch guard and press and hold the yellow button for five seconds. As the regen process is initiated, engine rpm increases and the HEST lamp illuminates to indicate extremely high exhaust temperatures.

**IMPORTANT:** The driver must remain with the vehicle during the entire regen cycle.

4. The regen cycle will finish after 20 to 60 minutes, at which time engine idle speed drops to normal and the vehicle can be driven normally. The HEST lamp is extinguished when vehicle speed exceeds 5 mph (8 km/h) or the system has cooled to normal operating temperature.
5. To stop a parked regen at any time during the process:
  - depress the clutch pedal, brake pedal, or accelerator pedal;
  - press and hold the regen inhibit switch until idle returns to normal;
  - shut down the engine.

## ATS Warning Lamps

There are three warning lamps that alert the driver of high exhaust temperature, the need to perform a parked regen or service the DPF, or of an engine fault that affects emissions. A decal attached to the driver's sun visor explains the ATS warning lamps. [Fig. 11.3](#).

See [Fig. 11.4](#) for an explanation of the ATS warnings, and actions required to avoid engine protection sequences.

## Malfunction Indicator Lamp (MIL)

A steadily illuminated yellow malfunction indicator lamp (MIL) indicates an engine fault that affects emissions. See [Fig. 11.5](#).

## DPF Status Lamp

When soot accumulates in the DPF and the DPF status lamp illuminates, see [Fig. 11.6](#), perform a parked regen or bring the vehicle up to highway speed to increase the load (thus starting an active regen).

If the DPF status lamp blinks while the CHECK engine lamp is illuminated, initiate a parked regen immediately in order to prevent an engine derate.

If the red STOP engine lamp illuminates with the blinking DPF lamp and the CHECK engine lamp, begin a parked regen in order to prevent an engine shutdown. Park the vehicle and perform a parked regen.

## High Exhaust System Temperature (HEST) Lamp

Slow (10-second) flashing of the high exhaust system temperature (HEST) lamp indicates that a parked regen is in progress, and the engine's high idle speed is being controlled by the engine software, not the vehicle driver.

Steady illumination of the HEST lamp alerts the driver of high exhaust temperature during the regen process if the vehicle speed is below 5 mph (8 km/h), or during a parked regen. See [Fig. 11.7](#).

## DPF Maintenance

Authorized service facilities must perform any DPF service. For warranty purposes, maintain a record that includes:

- date of cleaning or replacement;
- vehicle mileage;
- particulate filter part number and serial number.

## Diesel Exhaust Fluid and Tank

### Diesel Exhaust Fluid

Diesel exhaust fluid (DEF) is used in the ATS to lower NOx in the exhaust stream. DEF is colorless and close to odorless (it may have a slightly pungent odor similar to ammonia). It is nontoxic, nonflammable, and biodegradable. It is mildly corrosive to aluminum, but does not affect the strength or structure of the aluminum.

White crystals may be noticeable around components that come into contact with DEF. The crystals are easily removed with water.

DEF consumption varies depending on ambient conditions and vehicle application.

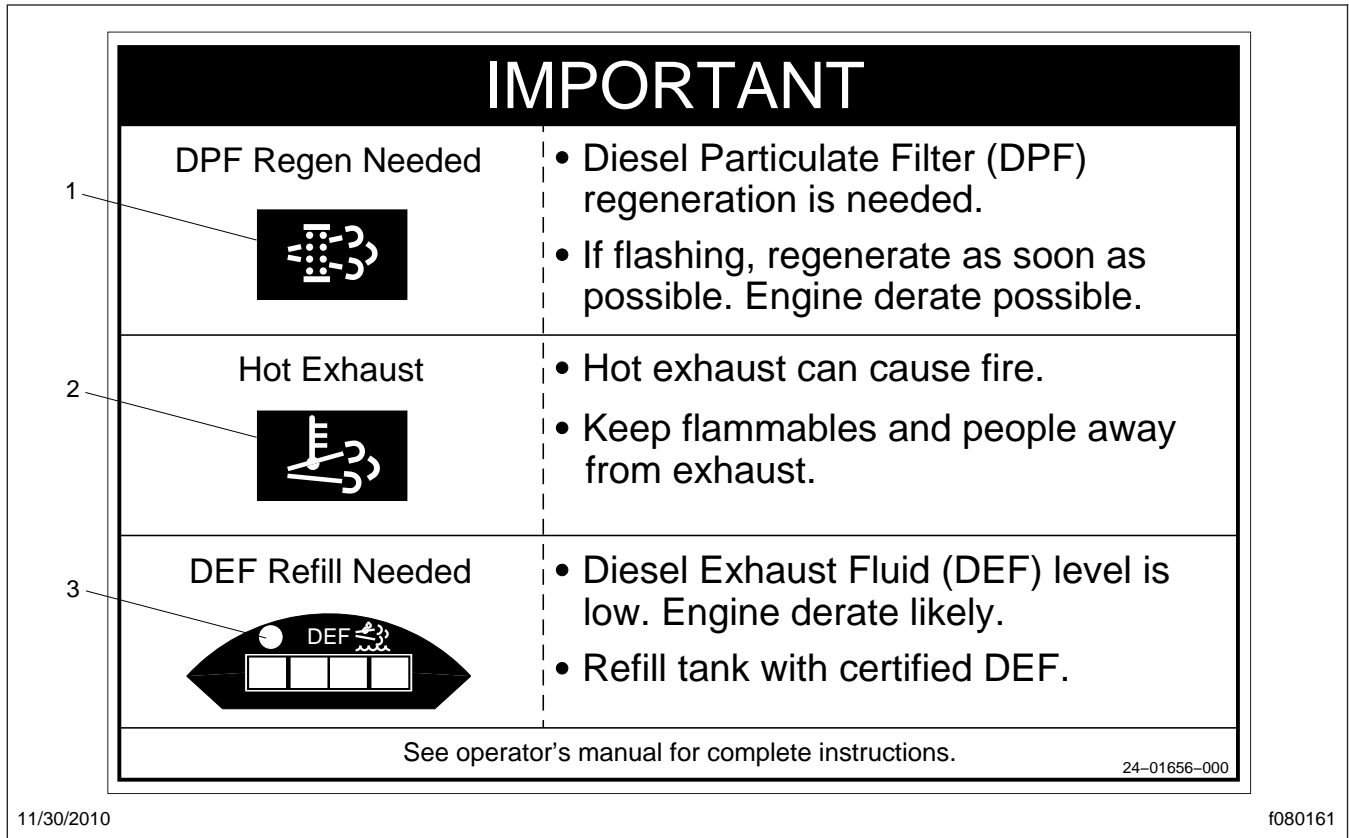


Fig. 11.3, Warning Lamp Decal, Sun Visor

## Freezing Conditions

DEF freezes to slush at around 12°F (-11°C). It is not damaged or destroyed if frozen, and is fully usable when thawed. The DEF in the tank is allowed to freeze while a vehicle is non-operational. At start-up, normal operation of the vehicle is not inhibited if the DEF is frozen; an immersion heater with engine coolant flowing through it warms the DEF once the engine is running, allowing the SCR system to operate.

Pre-2013 DEF supply lines are electrically-heated and are purged when the engine is shut down; complete purging of the DEF lines requires approximately five minutes after the engine is shut down.

DEF supply lines with engine model year 2013 and newer are designed to survive freezing conditions while containing DEF, so purging is not required.

## DEF Tank

Engines that are compliant with EPA10 and newer regulations are equipped with a DEF tank located on the driver's side of the vehicle behind the battery box or forward of the fuel tank. See [Fig. 11.8](#) and [Fig. 11.9](#). The DEF tank has a 19 mm filler neck inlet that prevents the hose from a diesel outlet from being inserted, and has a blue cap for easy identification.






## Fuel/DEF Gauge

The diesel fuel and DEF levels are measured in a dual-purpose gauge. See [Fig. 11.10](#).

Fuel level is indicated at the top of the gauge. Below the fuel level, a low fuel warning lamp illuminates amber when the fuel level drops below 1/8th of the capacity.

The lower portion of the gauge has a DEF warning lamp that illuminates amber when the DEF tank is

# Emissions and Fuel Efficiency

| EXHAUST AFTERTREATMENT SYSTEM INFORMATION   |  |   |   |  |   |
|---|--|---|---|--|---|
| INDICATOR LAMP(S)   |  (Solid)<br>Level 1     |  (Flashing)<br>Level 2   |  (Flashing) CHECK<br>Level 3 |  (Flashing) CHECK STOP<br>Level 4  |  WARNING   |
| Indicator Lamp Message(s)   | Filter Regeneration Recommended  | Filter Regeneration Necessary   | Parked Regeneration Required – Engine Derate  | Parked Regeneration Required – Engine Shut Down  | HEST (High Exhaust System Temperature)  |
| Diesel Particulate Filter Condition   | Filter is reaching capacity.   | Filter is now reaching maximum capacity.  | Filter has reached maximum capacity.  | Filter has exceeded maximum capacity.  | <b>Flashing</b><br>A regeneration is in progress.   |
| Required Action   | Bring vehicle to highway speeds to allow for an Automatic Regeneration or perform a Parked Regeneration. | To avoid engine derate bring vehicle to highway speeds to allow for an Automatic Regeneration or perform a Parked Regeneration as soon as possible. | Vehicle must be parked and a Parked Regeneration must be performed – engine will begin derate.                | Vehicle must be parked and a Parked Regeneration or Service Regeneration must be performed. Check engine operator's manual for details –engine will shut down. | <b>Solid</b><br>Exhaust Components and exhaust gas are at high temperature. When stationary, keep away from people and flammable materials or vapors. |
| For a driver performed Parked Regeneration, vehicle must be equipped with a dash mounted Regeneration Switch. |  |   |   |  |   |
| <b>See Engine Operator's Manual for complete Regeneration Instructions.</b>                                   |  |   |   |  |   |
| <small>24-01583-0008</small>  |  |   |   |  |   |

06/29/2009

f080147

Fig. 11.4, ATS Warning Lamps

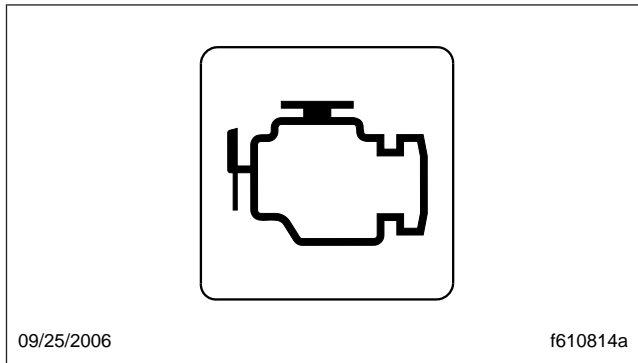


Fig. 11.5, Malfunction Indicator Lamp (MIL)

near empty, and a lightbar that indicates the level of DEF in the tank. The DEF light bar illuminates as follows.

- Four bars illuminated green—Between 75% and 100% full
- Three bars illuminated green—Between 50% and 75% full
- Two bars illuminated green—Between 25% and 50% full

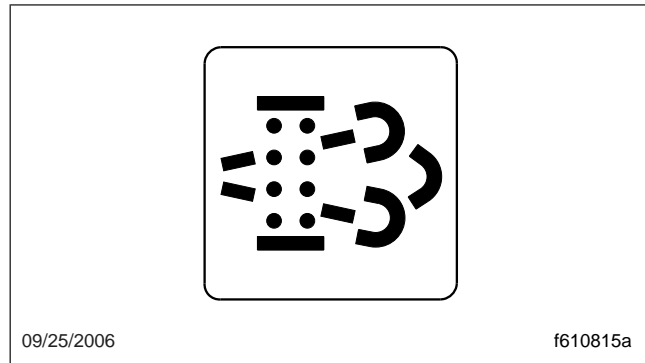


Fig. 11.6, DPF Status Lamp

- One bar illuminated green—Between approximately 10% and 25% full
- One bar illuminated amber—DEF very low, refill DEF
- One bar flashing red—DEF empty, refill DEF

## DEF Warnings and Engine Limits

**IMPORTANT:** Ignoring the DEF warning lights results in limited engine power, with the application of a 5 mph (8 km/h) speed limit.

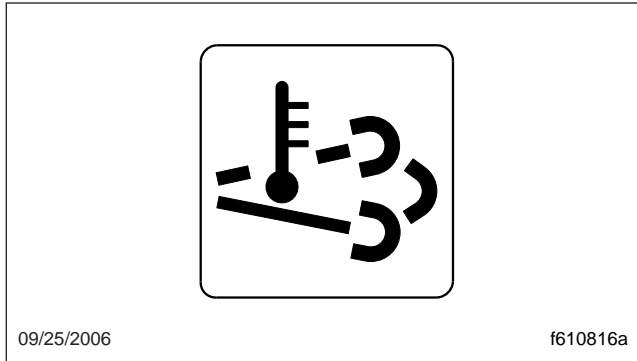


Fig. 11.7, HEST Lamp

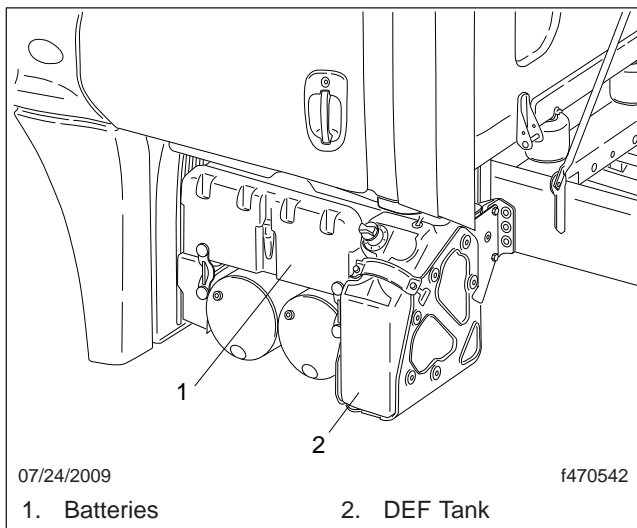


Fig. 11.8, DEF Tank Located Behind the Battery Box

## DEF Level Low—Initial Warning

When the DEF level is low, the following lamps notify the driver. See [Fig. 11.11](#). Refill the DEF tank in order to cancel the warning sequence.

- One bar of the DEF level indicator illuminates amber—DEF very low, refill DEF.
- The DEF warning lamp illuminates solid amber.

## DEF Empty

When the DEF level reads empty, the following lamps notify the driver. See [Fig. 11.12](#).

- One bar of the DEF level indicator flashes red—DEF empty, refill DEF.
- The DEF warning lamp flashes amber.

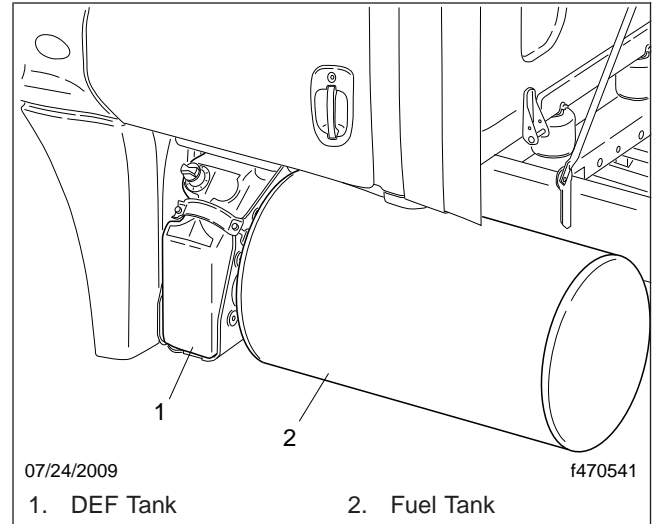


Fig. 11.9, DEF Tank Located Forward of the Fuel Tank

- The MIL lamp illuminates.

Pre-2013 Detroit engines: Power is limited, with a 55 mph (90 km/h) speed limit.

Cummins and 2013 Detroit engines: Power is limited with progressively harsher engine power limits applied.

## DEF Tank Empty and Ignored

If the empty warning is ignored and the DEF tank is not refilled, the red STOP engine lamp illuminates in addition to the MIL lamp and CHECK engine lamp (on vehicles with a Cummins ISB or ISC/L engine.) See [Fig. 11.13](#).

If the DEF is not refilled, a 5 mph (8 km/h) speed limit is applied after the next engine shutdown, while parked and idling, or if a fuel refill is detected.

## DEF Contamination or SCR Tampering

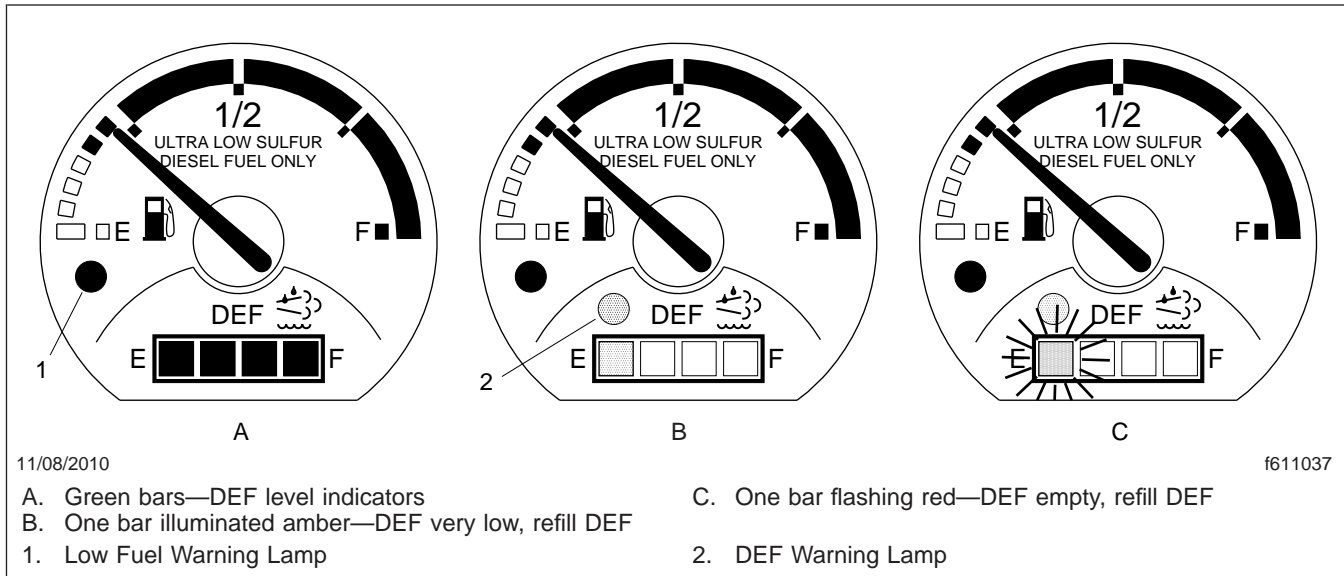
### NOTICE

Once contaminated DEF or tampering has been detected, the vehicle must be taken to an authorized service facility to check the SCR system for damage and to deactivate the warning lights and engine limits.

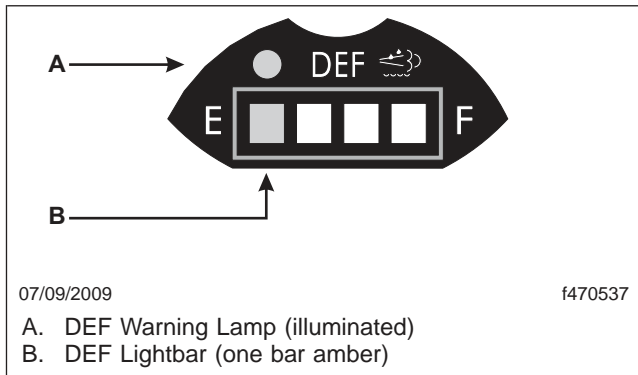
If contaminated DEF or tampering with the ATS is detected, the DEF warning light flashes and the MIL



# Emissions and Fuel Efficiency



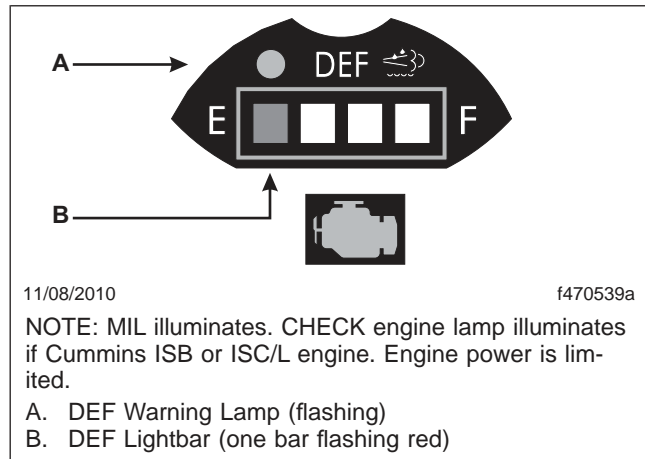
**Fig. 11.10, Fuel/DEF Gauge**



**Fig. 11.11, DEF Level Low Initial Warning**

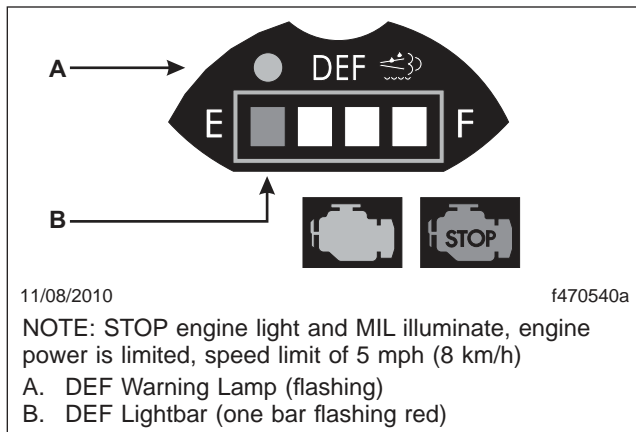
lamp illuminates to warn the driver. The CHECK engine lamp also illuminates on vehicles with a Cummins ISB or ISC/L engine. See [Fig. 11.13](#).

- Detroit engines: Engine power is limited with progressively harsher limits applied. If the fault is not corrected, the STOP engine light illuminates and a 5 mph (8 km/h) speed limit is applied after the next engine shutdown, while parked and idling, or if a fuel refill is detected.
- Cummins engines: Engine power is limited with progressively harsher limits applied. If the fault is not corrected, the STOP engine light illuminates and a 5 mph (8 km/h) speed limit is applied after the next engine shutdown, or while parked and idling.



**Fig. 11.12, DEF Empty Warning**

plied after the next engine shutdown, or while parked and idling.



**Fig. 11.13, DEF Empty and Ignored Warning**

# 12

## Brake Systems

---

|  |      |
|--|------|
| Air Brake System .....                             | 12.1 |
| Meritor WABCO® Antilock Braking System (ABS) ..... | 12.3 |

# Brake Systems

---

## Air Brake System

### General Information

A dual air brake system consists of two independent air systems that use a single set of brake controls. Each system has its own reservoirs, plumbing, and brake chambers. The primary system operates the service brakes on the rear axle; the secondary system operates the service brakes on the front axle. Service brake signals from both systems are sent to the trailer.

#### WARNING

**Do not operate the vehicle with the front brakes backed off or disconnected. Backing off or disconnecting the front brakes will not improve vehicle handling and may lead to loss of vehicle control, resulting in property damage or personal injury.**

**IMPORTANT:** On TRACTORS, loss of air pressure in the primary system causes the rear service brakes to become inoperative; front brakes will continue to be operated by secondary system air pressure. On TRUCKS, loss of air pressure in the primary system causes the rear spring brakes to get modulated, controlled by a secondary air signal. In addition, on TRACTORS and TRUCKS, trailer brakes will be operated by the secondary system.

Before driving your vehicle, allow time for the air compressor to build up a minimum of 100 psi (689 kPa) pressure in both the primary and secondary systems. Monitor the air pressure system by observing the dual system air pressure gauge and the low-air-pressure warning light and buzzer. The warning light and buzzer shut off when air pressure in both systems reaches 64 to 76 psi (441 to 524 kPa).

The warning light and buzzer come on if air pressure drops below 64 to 76 psi (441 to 524 kPa) in either system. If this happens, check the dual system air pressure gauge to determine which system has low air pressure. Although the vehicle's speed can be reduced using the foot brake control pedal, either the front or rear service brakes will not be operating at full capacity, causing a longer stopping distance. Bring the vehicle to a safe stop, and have the air system repaired before continuing.

**IMPORTANT:** In the event of a total loss of service brakes with full system air pressure, use the parking brake control valve (yellow knob) to bring the vehicle to a complete stop in the safest location possible.

Before the vehicle can be moved, the spring parking brakes must be released by applying an external air source at the gladhands, or by manually caging the parking brake springs.

#### WARNING

**Do not release the spring parking brakes and then drive the vehicle. There would be no means of stopping the vehicle, which could result in serious personal injury or vehicle damage. Before releasing the spring parking brakes, make the connection to a towing vehicle or chock the tires.**

After correcting the brake system problem, uncage the spring parking brakes before resuming normal vehicle operation.

### Brake System Operation

**IMPORTANT:** Before driving the vehicle, secure all loose items in the cab so that they will not fly forward during a full brake application. Make sure all passengers are wearing seat belts.

During normal brake stops, depress the foot brake control pedal until braking action slows down the vehicle. Increase or decrease the pressure on the pedal so that the vehicle comes to a smooth, safe stop. Apply the spring parking brakes if the vehicle is to be parked.

**IMPORTANT:** An air brake proportioning system is used in tractor air brake systems when the vehicle is not equipped with ABS. When operating in bobtail mode, the rear brake chambers (whose axle load has been greatly reduced) receive reduced or proportional air pressure, while the front axle brake chambers receive full (normal) air pressure. This results in a different brake pedal "feel," as the pedal seems to require more travel and/or effort to slow or stop the vehicle. However, the air brake proportioning system actually improves vehicle control when the tractor is in the bobtail mode of operation. When the tractor is towing a trailer, the rear

brake chambers will receive full (normal) application air pressure.

The trailer brake lever (hand control valve) is used for applying the trailer brakes without applying the truck or tractor service brakes. It is usually mounted on the right-hand control panel. See [Fig. 12.1](#). The valve can be partially or fully applied, but in any partially on position it will be overridden by a full application of the service brake pedal. Moving the lever down applies the trailer brakes, while moving it up releases the trailer brakes. The lever will automatically return to the up position when it is released.

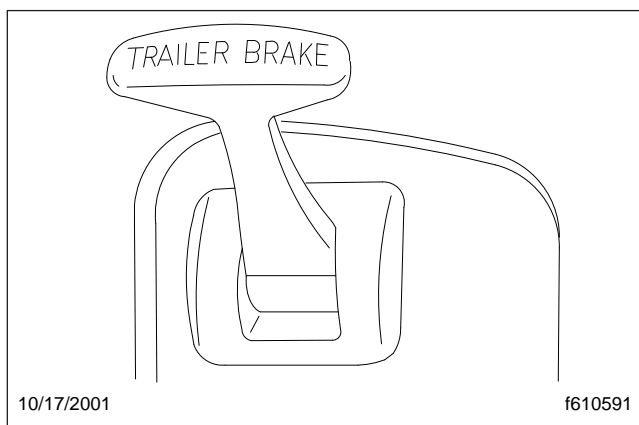


Fig. 12.1, Trailer Brake Lever

## WARNING

**Do not use the trailer service brakes for parking; they are not designed for this purpose. If air bleeds out of the trailer air tank during parking, the vehicle could roll, causing serious personal injury or property damage.**

The red octagonal-shaped knob in the control panel actuates the trailer air supply valve. See [Fig. 12.2](#). After the vehicle's air hoses are connected to a trailer, and the pressure in both air systems is at least 65 psi (448 kPa), the red knob must be pushed in. It should stay in, to charge the trailer air supply system and to release the trailer spring parking brakes. It must be pulled out before disconnecting a trailer. It must also be pulled out when operating a vehicle without a trailer. If pressure in both air systems drops to 35 to 45 psi (242 to 310 kPa), the red knob automatically pops out, exhausting the trailer air supply, and applying the trailer service or spring parking brakes.

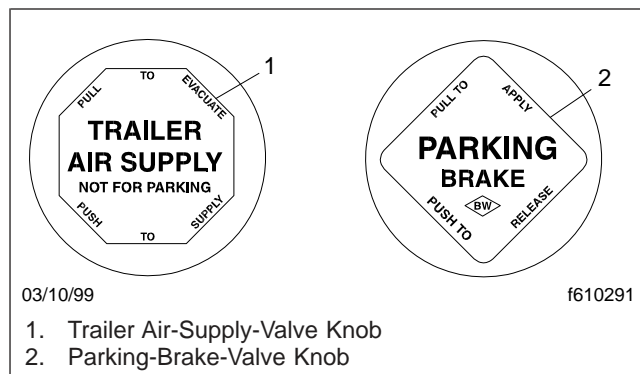


Fig. 12.2, Brake Valve Knobs

The yellow diamond-shaped knob in the control panel actuates the parking brake valve. See [Fig. 12.2](#). Pulling out the knob applies both the tractor and trailer spring parking brakes and automatically causes the trailer air-supply-valve knob to pop out.

## NOTICE

**Do not use the spring parking brakes if the service brakes are hot, such as after descending a steep grade. To do so could damage the brakes. Allow hot brakes to cool before using the spring parking brakes.**

**Do not use the spring parking brakes during freezing temperatures if the service brakes are wet. To do so could cause them to freeze. If the brakes are wet, drive the vehicle in low gear and lightly apply the brakes to heat and dry them.**

If the trailer is not equipped with spring parking brakes, pulling out the yellow knob applies the tractor spring parking brakes and the trailer service brakes. When the tractor and trailer parking brakes (or trailer service brakes) are both applied, the trailer brakes are released by pushing in the red knob, leaving the tractor parking brakes applied. Air pressure in the primary or secondary reservoir must be at least 65 psi (447 kPa) before the tractor spring parking brakes, or the trailer service or spring parking brakes, can be released.

On trailers not equipped with spring parking brakes, chock the trailer tires before disconnecting the truck or tractor when parking just the trailer.

When parking a truck or tractor with a trailer (combination vehicle), and the trailer is not equipped with

# Brake Systems

---

spring parking brakes, apply the truck or tractor spring parking brakes.

## WARNING

**If a trailer or combination vehicle is not equipped with spring parking brakes, do not park it by pulling out only the trailer air supply valve knob. This would apply only the trailer service brakes. If air were to bleed from the trailer brake system, the trailer brakes would release, possibly causing an unattended runaway vehicle.**

## NOTICE

**Never apply the service and spring parking brakes simultaneously. To do so transmits excessive input force to the brake components, which could damage or cause eventual failure of brake actuating components.**

## Automatic Slack Adjusters

Automatic slack adjusters should never be manually adjusted except during routine maintenance of the foundation brakes (e.g., replacing shoes), during slack adjuster installation, or in an emergency situation.

When the brake pushrod stroke exceeds the legal brake adjustment limit on a vehicle, there is likely a mechanical problem with the foundation brake components or the adjuster is improperly installed.

Visit a repair facility as soon as possible when brakes equipped with automatic slack adjusters are determined to be out of adjustment.

## NOTICE

**Manually adjusting an automatic slack adjuster to bring the pushrod stroke within legal limits is likely masking a mechanical problem. Adjustment is not repairing. In fact, continual adjustment of automatic slack adjusters may result in premature wear of the adjuster itself. Further, the improper adjustment of some automatic slack adjusters may cause internal damage to the adjuster, thereby preventing it from properly functioning.**

## Meritor WABCO® Antilock Braking System (ABS)

The Meritor WABCO Antilock Braking System (ABS) is an electronic wheel speed monitoring and control system that works with the standard air brake system. ABS passively monitors vehicle wheel speed at all times, and *controls* wheel speed during emergency stops. If equipped with Automatic Traction Control (ATC), wheel spin is controlled during reduced-traction situations. In normal braking applications, the standard air brake system is in effect.

**IMPORTANT:** For proper ABS system operation, do not change tire sizes. The sizes of the tires installed during production are programmed into the electronic control unit. Installing different-sized tires could result in a reduced braking force, leading to longer stopping distances.

ABS includes signal-generating tone wheels and sensors located in the wheel hubs of each sensed wheel. The sensors transmit vehicle wheel speed information to an electronic control unit (located behind the center dash). The control unit's main circuit interprets the speed sensor signals and calculates wheel speed, wheel retardation, and a vehicle reference speed. If the calculations indicate wheel lockup, the main circuit signals the appropriate modulator valve to reduce braking pressure. During emergency braking, the modulator valve alternately reduces, increases, or maintains air pressure supply in the brake chamber to prevent front and rear wheel lockup.

If equipped with ATC, an additional solenoid valve is installed. During reduced-traction situations, the ATC solenoid valve controls air pressure to the modulator valves, and they in turn increase, hold, or reduce pressure to the appropriate brake chambers to provide better traction whenever wheel spin occurs.

The electronic control unit also has a safety circuit that constantly monitors the wheel sensors, traction control valve (if equipped), modulator valves, and the electrical circuitry.

After the ignition switch is turned on, the tractor warning light (TRACTOR ABS) and, if equipped with automatic traction control, the wheel spin indicator light come on for about three seconds. After three seconds, the warning lights go out only if all of the tractor's ABS components are working.

Vehicles with electronic engines and ABS may have ATC. On these vehicles, the ATC system automatically limits wheel spin during reduced-traction situations.

If the vehicle has ATC, there will be a momentary contact rocker switch on the dash labeled ATC.

When the ATC system is in the NORMAL mode, it will apply gentle braking to the spinning wheel, to feed power to the wheel(s) with better traction. If both wheels are spinning, the system will signal the electronic engine to reduce power.

Pressing the switch will temporarily allow more drive wheel spin, to help burn through a thin layer of ice, or to help throw off accumulated mud or snow. SPIN mode is indicated by a flashing WHEEL SPIN light. Pressing the switch again will cycle the system back to normal operation.

The Meritor WABCO ABS system combines one front-axle control channel with one rear axle to form one control circuit. For example, the sensor and modulator valve on the left-front axle form a control circuit with the sensor and modulator valve on the right-rear axle. If, during vehicle operation, the safety circuit senses a failure in any part of the ABS system (a sensor, modulator valve, wiring connection, short circuit, etc.), the tractor warning light (TRACTOR ABS) comes on and the control circuit where the failure occurred is switched to normal braking action. The remaining control circuit will retain the ABS effect. Even if the ABS system is completely inoperative, normal braking ability is maintained. An exception would be if a modulator valve (or combination modulator valve) is damaged and inoperative. As these components are an integral part of the air brake system, normal braking may be impaired or inoperative.

**IMPORTANT:** If any of the ABS warning lights do not work as described above, or come on while driving, repair the ABS system immediately to ensure full antilock braking capability.

During emergency or reduced-traction stops, fully depress the brake pedal until the vehicle comes to a safe stop; *do not pump* the brake pedal. With the brake pedal fully depressed, the ABS system will control all wheels to provide steering control and a reduced braking distance.

Although the ABS system improves vehicle control during emergency braking situations, the driver still

has the responsibility to change driving styles depending on the existing traffic and road conditions. For example, the ABS system cannot prevent an accident if the driver is speeding or following too closely.

## Trailer ABS Lamp Operation

Antilock Braking Systems (ABS) on tractors are designed to communicate with trailer ABS systems, if they are compatible. Compatibility will result in the illumination of the trailer ABS lamp during vehicle start-up and fault detection.

The dash-mounted lamp will operate as follows when a compatible trailer is properly connected to a tractor:

- When the ignition key is turned to the ON position, the trailer ABS lamp will illuminate momentarily, then turn off.
- If the lamp comes on momentarily during vehicle operation, then shuts off, a fault was detected and corrected.
- If the lamp comes on and stays on during vehicle operation, there is a fault with the trailer ABS. Repair the trailer ABS system immediately to ensure full antilock braking capability.

The Trailer ABS lamp will not illuminate unless a compatible trailer is connected to the tractor.

**IMPORTANT:** If a compatible trailer is connected, and the lamp is not illuminating momentarily when the ignition key is turned to the ON position, it is possible that the lamp is burnt out.

# 13

## Manual Transmissions and Clutch

---

|   |      |
|---|------|
| Eaton Fuller 13-Speed and 18-Speed Splitter and Range-Shift Transmissions ..... | 13.1 |
| Eaton Fuller 10-Speed Range-Shift Transmissions .....                           | 13.4 |
| Clutch .....  | 13.5 |



# Manual Transmissions and Clutch

## Eaton Fuller 13-Speed and 18-Speed Splitter and Range-Shift Transmissions

For complete information on Eaton transmissions, go to the Eaton Roadranger website, [www.roadranger.com](http://www.roadranger.com).

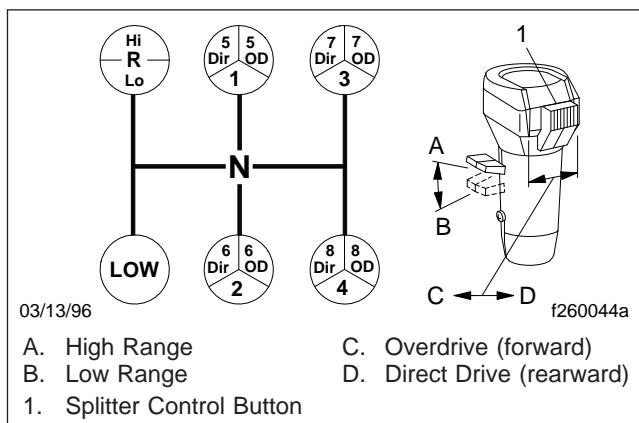
### General Information, Eaton Fuller Splitter and Range-Shift

Combination splitter and range-shift transmissions allow the choice of two splitter ratios in each lever position, as well as the additional ratio provided in each lever position after shifting to the other range.

**IMPORTANT:** Not all lever positions are used in each range, and the shift patterns vary between transmissions. Be sure to read the shift pattern decal on the dash, for the operating instructions for the specific transmission installed in your vehicle.

### 13-Speed RTLO Models

Eaton Fuller 13-speed transmissions have thirteen forward speeds and two reverse speeds. Each transmission consists of a 5-speed front section, and a 3-speed auxiliary section. The auxiliary section contains low- and high-range ratios, plus an overdrive splitter gear. See **Fig. 13.1** for the shift pattern.



**Fig. 13.1, Eaton Fuller 13-Speed Transmission Shift Pattern**

All of the 13 speeds are controlled with one shift lever. A range-preselection lever and a splitter-control

button are built into the shift knob. The range-preselection lever controls range selection and the splitter-control button (located on the side of the shift knob) controls gear splits.

Low gear in the front section is used only as a starting ratio. The remaining four forward positions are used once in the low range and once in the high range. However, each of the four high range gear positions can be split with the underdrive ratio (RT models), or overdrive ratio (RTO models) of the splitter gear. Ratios cannot be split while the transmission is in low range.

### 18-Speed RTLO Splitter and Range-Shift Models

Eaton Fuller 18-speed transmissions have 18 forward speeds and four reverse speeds. These transmissions consist of a 5-speed front section and a 3-speed auxiliary section. The auxiliary section contains low and high range ratios, plus an overdrive splitter gear.

One ratio in the front section (low) is used as a starting ratio; it is never used when the transmission is in high range. Low gear can be split, to provide both a direct and an overdrive ratio.

The other four ratios in the front section are used once in low range, and once again in high range. However, each of the five ratios (low-1-2-3-4) in low range, and each of the four ratios (5-6-7-8) in high range, can be split with the overdrive splitter gear.

All of the 18 speeds are controlled with one shift lever. A range-preselection lever and a splitter-control button are built into the shift knob. The range-preselection lever controls range selection and the splitter-control button (located on the side of the shift knob) controls gear splits.

### Operation Tips, Eaton Fuller Splitter and Range-Shift

**IMPORTANT:** The shifter knob has an interlock feature that prevents the splitter-control button from being moved forward when the range-preselection lever is down (in low range); when in high range and the splitter-control button is in the forward position, the range-preselection lever cannot be moved down.

# Manual Transmissions and Clutch

The following tips highlight important operation principles.

- For all conditions, use the highest gear that is still low enough to start the vehicle moving with the engine at or near idle speed, and without slipping the clutch excessively.

When operating on-highway, with no load, or under ideal conditions, use 1st gear when starting to move the vehicle forward.

When operating off-road, or under adverse conditions, always use low gear when starting to move the vehicle forward.

- Use the clutch brake to stop gear rotation when shifting into low (or 1st) or reverse when the vehicle is stationary. The clutch brake is actuated by depressing the clutch pedal all the way to the floor.

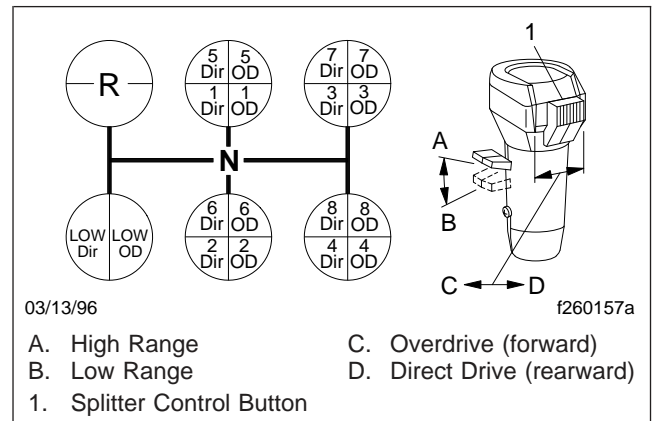
For normal upshifts and downshifts, only a partial disengagement of the clutch is necessary to break engine torque.

- Use double-clutching between all upshifts and downshifts that require movement of the shift lever. Splitting of the high range gears does not require movement of the shift lever.
- Never move the shift lever into low gear while in high range.
- Never move the splitter-control button while in neutral.
- Do not preselect with the splitter-control button; after moving the control button, complete the shift immediately.
- Except when downshifting from 5th direct to 4th gear, never push the range-preselection lever down into low range while operating in high range—the splitter will become inoperative.
- Do not shift from high range to low range at high vehicle speeds.
- Do not make range shifts with the vehicle moving in reverse gear.
- Never attempt to move the range-preselection lever with the gear-shift lever in neutral, while the vehicle is moving. Preselection with the range-preselection lever must be made prior to moving the shift lever out of gear into neutral.

- After your shifting ability improves, you may want to skip some of the ratios. This may be done *only* when operating conditions permit, depending on the load, grade, and road speed.

## Upshifting

1. Position the gear-shift lever in neutral. Start the engine, and bring the air system pressure up to 100 to 120 psi (689 to 827 kPa).
2. Position the range-preselection lever down, into low range. See [Fig. 13.2](#).



**Fig. 13.2, Eaton Fuller 18-Speed Transmission Shift Pattern**

3. Make sure the splitter-control button is in the direct (rearward) position. See [Fig. 13.2](#).
4. For 13-speed transmissions:  
Press the clutch to the floor, shift into low or 1st gear; then engage the clutch, with the engine at or near idle speed, to start the vehicle moving. Accelerate to 80 percent of engine governed speed.  
For 18-speed transmissions:  
Press the clutch to the floor, shift into low; then engage the clutch, with the engine at or near idle speed, to start the vehicle moving.  
To shift from low direct to low overdrive, move the splitter-control button into the overdrive (forward) position, then immediately release the accelerator. Press and release the clutch pedal. After releasing the clutch, accelerate again.
5. For 13-speed transmissions:

# Manual Transmissions and Clutch

---

Shift upward from low to 1st gear, 2nd, etc. until 4th gear, double-clutching between shifts, and accelerating to 80 percent of engine governed speed. See [Fig. 13.1](#).

For 18-speed transmissions:

Shift upward from low overdrive to 1st direct by first moving the splitter-control button into the direct (rearward) position ([Fig. 13.2](#)). Move the shift lever, double-clutching, to the 1st gear position.

Continue upshifting through the shift pattern. Double-clutch during lever shifts (1st to 2nd to 3rd to 4th); single-clutch during split shifts (1st direct to 1st overdrive, etc.).

6. When in 4th gear (13-speed transmissions) or 4th overdrive (18-speed transmissions) and ready to shift up to 5th gear, use the range shift lever as follows:

For 13-speed transmissions:

While in 4th gear, pull the range shift preselection lever up, into high range. The transmission will automatically shift from low to high range as the shift lever passes through neutral. Then, disengage the clutch; double-clutch through neutral; move the shift lever to 5th gear; engage the clutch, and accelerate the engine.

For 18-speed transmissions:

While in 4th overdrive, pull the range shift preselection lever up, into high range. The transmission will automatically shift from low to high range as the shift lever passes through neutral.

Move the shift lever, double-clutching, to the 5th gear position. Just before making final clutch engagement, move the splitter-control button to the direct (rearward) position; then engage the clutch and accelerate. Do not move the control button while the shift lever is in neutral.

7. Shift up through the high range gears as follows:

For 13-speed transmissions:

To shift from 5th direct to 5th overdrive, move the splitter-control button ([Fig. 13.1](#)) into the overdrive (forward) position, then immediately release the accelerator. Press and release the clutch pedal. After releasing the clutch, accelerate again.

Continue upshifting through the shift pattern. Double-clutch during lever shifts (6th to 7th to 8th); single-clutch during split shifts (6th direct to 6th overdrive, etc.).

For 18-speed transmissions:

To shift from 5th direct to 5th overdrive, move the splitter-control button ([Fig. 13.2](#)) into the overdrive (forward) position, then immediately release the accelerator. Press and release the clutch pedal. After releasing the clutch, accelerate again.

Continue upshifting through the shift pattern. Double-clutch during lever shifts (6th to 7th to 8th); single-clutch during split shifts (6th direct to 6th overdrive, etc.).

## Downshifting

1. Downshift from 8th overdrive to 8th direct without moving the shift lever. Flip the splitter-control button to the direct (rearward) position, then immediately release the accelerator, and disengage the clutch. Engage the clutch, and accelerate the engine only after the transmission has shifted.
2. Start the downshift from 8th direct to 7th overdrive by flipping the splitter-control button to the overdrive (forward) position; then, immediately double-clutch through neutral, moving the shift lever from 8th to 7th gear.
3. Shift downward through each of the high range gears, alternating the procedures in steps 1 and 2, above, until reaching 5th direct.
4. While in 5th direct and ready for the downshift to 4th (13-speed transmissions) or 4th overdrive (18-speed transmissions), push the range-preselection lever down. Then, double-clutch through neutral and move the shift lever to the 4th gear position. On 18-speed transmissions, move the splitter-control button to the overdrive (forward) position *before* engaging the clutch. Do not move the control button while the shift lever is in neutral.
5. Continue downshifting from 4th to 1st as follows:  
For 13-speed transmissions:  
Downshift through the low range gears as conditions require.  
For 18-speed transmissions:

# Manual Transmissions and Clutch

Continue downshifting from 4th overdrive to 4th direct, then 4th direct to 3rd overdrive, 3rd overdrive to 3rd direct, etc. Single-clutch when split shifting (direct to overdrive, overdrive to direct). Double-clutch when making lever shifts (4th to 3rd, 3rd to 2nd, etc.).

**IMPORTANT:** Never use the clutch brake when downshifting, or as a brake to slow the vehicle.

## Eaton Fuller 10-Speed Range-Shift Transmissions

For complete information on Eaton transmissions, go to the Eaton Roadranger website, [www.roadranger.com](http://www.roadranger.com).

### General Information, Eaton Fuller Range-Shift

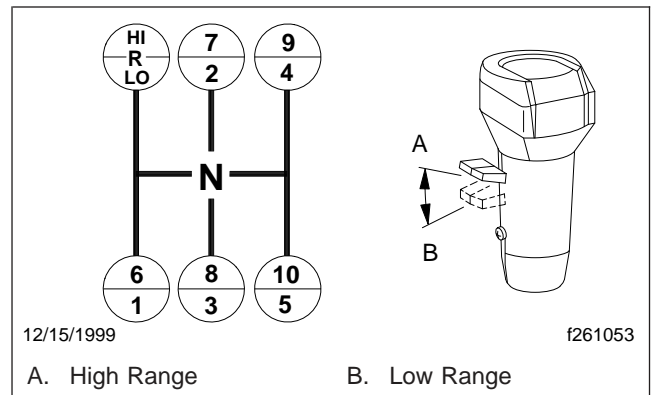
To operate a range-shift transmission, move the shift lever through all the low gear positions and then activate a range switch to provide an additional set of ratios in the high range. Using the same shift lever positions as in low range, move the shift lever through each position as before. On some models, the initial low gear is often used only in low range.

**IMPORTANT:** Not all lever positions are used in each range and the shift patterns vary between transmissions. Be sure to read the shift pattern decal on the dash for the operating instructions for the specific transmission installed in your vehicle.

### 10-Speed FR/FRO and RT/RTO/RTX Models

Eaton Fuller 10-speed transmissions have 10 selective, evenly spaced forward ratios. Each transmission has a 5-speed front section and a 2-speed rear range section. The 10 forward speeds are obtained by twice using a 5-speed shift pattern: the first time in low range, the second time in high range. See **Fig. 13.3** for the shift patterns.

**NOTE:** The 4th/9th and the 5th/10th shift positions in the RT (direct ratio) and RTX (overdrive ratio) transmissions are directly opposite in the RTO (overdrive ratio) transmissions



**Fig. 13.3, Eaton Fuller 10-Speed Transmission Shift Patterns**

### Operation Tips, Eaton Fuller Range-Shift

The following tips highlight important operation principles.

- When operating off-highway, or under adverse conditions, always use low gear (if so equipped) when starting to move the vehicle.

When operating on-highway, with no load, or under ideal conditions, use 1st gear when starting to move the vehicle (except when equipped with a 9-speed RTO transmission, then always start in low gear).

For all conditions, use the highest gear that is still low enough to start the vehicle moving with engine idling, and without slipping the clutch excessively.

- Use the clutch brake to stop gear rotation when shifting into low (or 1st) or reverse when the vehicle is stationary. The clutch brake is actuated by depressing the clutch pedal all the way to the floor.

For normal upshifts and downshifts, only a partial disengagement of the clutch is necessary to break engine torque.

- Do not make range shifts with the vehicle moving in reverse gear.
- Do not shift from high range to low range at high vehicle speeds.
- Double-clutch between all upshifts and downshifts.

# Manual Transmissions and Clutch

- Never attempt to move the range preselection lever with the gear shift lever in neutral while the vehicle is moving. Preselection with the range preselection lever must be made prior to moving the shift lever out of gear into neutral.
- After your shifting ability improves, you may want to skip some of the ratios. This may be done *only* when operating conditions permit, depending on the load, grade, and road speed.

## Upshifting

1. Position the gear shift lever in neutral. Start the engine, and bring the air system pressure up to 100 to 120 psi (689 to 827 kPa).
2. Position the range preselection lever down, into low range.
3. Press the clutch pedal to the floor; shift into low or 1st gear ([Table 13.1](#)), then engage the clutch, with the engine at or near idle speed, to start the vehicle moving. Accelerate to 80 percent of engine governed speed.

| Eaton Fuller Shift Progressions          |             |            |            |
|--|-------------|------------|------------|
| TRANS. MODEL                             | LOW RANGE   |            | HIGH RANGE |
|  | Off-Highway | On-Highway |            |
| 10-Speed Direct or Overdrive (RT or RTX) |             |            |            |

**Table 13.1, Eaton Fuller Range-Shift Shift Progressions**

4. Shift progressively upward from low or 1st gear, to the top gear in low range ([Table 13.1](#)), double-clutching between shifts, and accelerating to 80 percent of engine governed speed.
5. While in the top gear of the low range shift pattern, and ready for the next upshift, flip the range preselection lever up into high range. Double-clutch through neutral, and shift into the bottom gear in high range ([Table 13.1](#)). As the shift lever passes through neutral, the transmission will automatically shift from low range to high range.
6. With the transmission in high range, shift progressively upward through each of the high range gears ([Table 13.1](#)), double-clutching between shifts.

## Downshifting

1. With the transmission in high range, shift progressively downward to the bottom gear in high range, double-clutching between shifts.
2. When in the bottom gear of the high range shift pattern, and ready for the next downshift, push the range preselection lever down into low range. Double-clutch through neutral, and shift into the top gear of the low range shift pattern. As the shift lever passes through neutral, the transmission will automatically shift from high range to low range.
3. With the transmission in low range, downshift through the low range gears as conditions require.

**IMPORTANT:** Never use the clutch brake when downshifting, or as a brake to slow the vehicle.

## Clutch

### General Information

To ensure long service life of the clutch; start in the right gear, be alert to clutch malfunctions, and know when to adjust the clutch.

Typical operation will not break down the clutch friction surfaces. However, if a clutch is slipped excessively, high temperatures develop quickly and destroy the clutch. Temperatures generated between the flywheel, driven discs, and pressure plates can be high enough to cause the friction facing material to char and burn.

Heat and wear are practically nonexistent when a clutch is fully engaged. But during the moment of engagement, when the clutch is picking up the load, it generates considerable heat. An improperly adjusted or slipping clutch will rapidly generate sufficient heat to destroy itself.

### Clutch Operation

#### Clutch Break-In

With a new or newly installed clutch, the clutch may slip for a short time while the friction surfaces break-in. However, allowing the clutch to slip for more than two seconds can severely damage the clutch disc, pressure plate, and the flywheel.

# Manual Transmissions and Clutch

---

During initial operation of a new vehicle or a vehicle with a new clutch, check for clutch slippage during acceleration. If the clutch slips, decelerate until the clutch does not slip. Allow the clutch to cool 15 to 30 seconds, and then gradually accelerate again. If the clutch continues to slip, repeat the procedure. If necessary, repeat the procedure up to five times. If the clutch slips after five attempts, stop the vehicle. Allow the clutch to cool for at least one hour. Notify your Freightliner dealer of the problem.

## NOTICE

**Do not allow sustained slippage of the clutch; this could severely damage the clutch disc, pressure plate, or flywheel. Damage caused by clutch slippage due to improper break-in is not warrantable.**

### Moving the Vehicle in the Proper Gear

An empty vehicle can be started in a higher transmission gear than can a partially or fully loaded vehicle. Select the gear combination that allows the vehicle to start moving with an idling engine, or, if necessary, just enough throttle to prevent stalling the engine. After the clutch is fully engaged, the engine can be accelerated to the correct rpm for the upshift into the next higher gear.

### Gear Shifting Techniques

Shift into the next higher gear when the vehicle speed allows the transmission input shaft speed to match the flywheel speed when engaging the clutch. This technique results in the smallest speed difference between the clutch disc and the flywheel and causes the least heat and wear on the clutch assembly. When downshifting, the input shaft speed must be increased by slightly revving the engine to match the flywheel speed for smooth clutch engagement. For transmission operating instructions, refer to the transmission headings in this manual.

### Vehicle Loading

Clutches are designed for specific vehicle applications and loads. These weight limitations should not be exceeded.

## NOTICE

**Exceeding vehicle load limits can not only result in damage to the clutch, but can also damage the entire powertrain.**

### Using the Clutch

The clutch pedal must be used only to start the vehicle moving or while shifting. To start the vehicle moving, depress the clutch pedal all the way to the floor plate (see "Using the Clutch Brake") and shift from neutral to a low gear. Slowly raise your foot until the clutch starts to engage. In this position the clutch is starting to connect the transmission input shaft to the flywheel and is causing the most heat and wear. Slightly increase the engine speed and smoothly allow the clutch pedal to return to its at rest position. Do not allow the clutch to remain in the partially engaged position any longer than necessary to obtain a smooth start.

To shift gears while the vehicle is moving, push the clutch pedal most of the way (but not all of the way) to the floor plate. Shift the transmission into neutral and fully release the clutch pedal. If upshifting, wait long enough for the engine speed to decrease to the road speed. If downshifting, increase the engine speed to match the road speed. Again, push down the clutch pedal part way and then move the shift lever to the next gear position. Fully release the clutch pedal after completing the shift.

Slightly depressing the clutch pedal while driving is damaging to the clutch, because partial clutch engagement causes slippage and heat. Resting your foot on the clutch pedal will also put a constant thrust load on the release bearing, thinning the bearing lubricant and increasing the wear on the bearing.

### Using the Clutch Brake

The clutch brake is applied by depressing the clutch pedal past the fully released clutch position, almost to the floor plate. The last part of the clutch pedal travel will compress the clutch brake plates together, stopping the transmission input shaft. The purpose of the clutch brake is to stop the transmission gears from rotating in order to quickly engage a transmission gear after idling in neutral.

# Manual Transmissions and Clutch

## NOTICE

Never apply the clutch brake when the vehicle is moving. If the clutch brake is applied when the vehicle is moving, the clutch brake will try to stop or decelerate the vehicle, causing rapid wear of the clutch brake friction discs. Considerable heat will be generated, causing damage to the release bearings and the transmission front bearings.

### Holding the Vehicle on an Incline

Always use the vehicle service brakes to prevent the vehicle from rolling backwards while stopped on a hill. Slipping the clutch on a hill to maintain the vehicle position will quickly damage the clutch assembly.

### Coasting

Coasting with the clutch pedal depressed and the transmission in a low gear can cause high driven disc speed. The clutch speed can be much higher under these conditions than when the engine is driving the clutch. This condition creates a hazardous situation due to the lack of vehicle control and due to the high clutch disc speed. Engaging the clutch under these conditions can cause component damage because of the shock loads to the clutch and drivetrain.

## WARNING

Always shift into the gear that is correct for the traveling speed of the vehicle and engage the clutch. Coasting with the clutch disengaged can prevent engagement of the correct transmission gear which can cause loss of vehicle control, possibly resulting in personal injury or property damage.

High clutch disc speeds while coasting can also cause the clutch facing to be thrown off the disc. Flying debris from the clutch can cause injury to persons in the cab.

### Clutch Maintenance

#### Checking the Clutch Adjustment

Reporting erratic clutch operation as soon as possible gives maintenance personnel a chance to in-

spect, lubricate, and adjust the clutch components. The driver can be aware of clutch wear by noticing the gradual decrease in the distance the clutch pedal moves before resistance is felt. A correctly adjusted clutch must have about 3/4 inch (19 mm) of travel at the top of its stroke before a stronger resistance can be felt. See Fig. 13.4. If the free pedal travel is less than this distance, have the clutch adjusted.

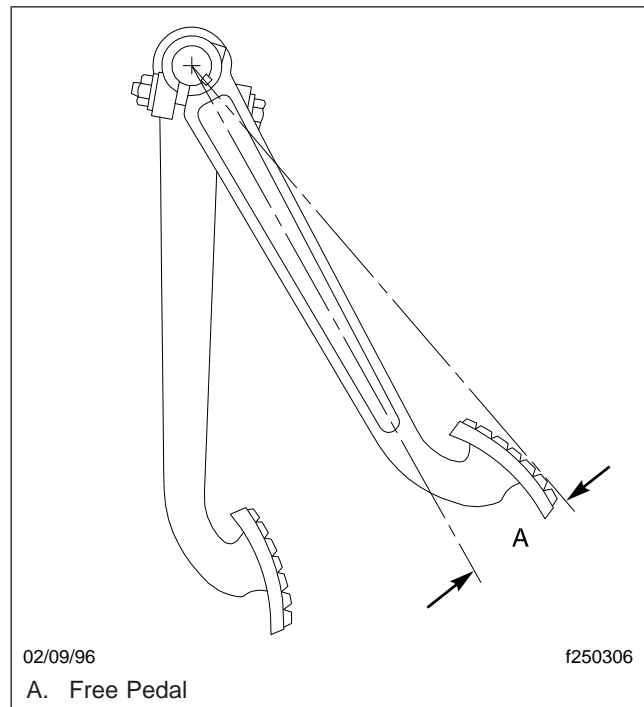


Fig. 13.4, Clutch Free Pedal Travel

The clutch pedal free travel should be checked and commented on daily in the driver's report.

See **Group 25** of the *122SD and Coronado Workshop Manual* for clutch adjustment procedures and specifications.

## NOTICE

Operating the vehicle with incorrect free pedal could result in clutch damage.

### Checking the Clutch Brake Operation

Clutch brake operation can be felt as an increased resistance as the clutch pedal approaches the bottom of its stroke. If the gears grind when shifting into first or reverse gear from neutral with the clutch

# Manual Transmissions and Clutch

---

pedal fully depressed, the clutch pedal is out of adjustment or the clutch brake is worn and needs to be replaced.

## **Adjusting the Clutch**

Clutches have an internal adjustment and external linkage adjustment. See **Group 25** of the *122SD and Coronado Workshop Manual* for clutch adjustment procedures and specifications.

## **Lubricating the Clutch Release Bearing**

On vehicles equipped with a greaseable release bearing, the release bearing should be lubricated at frequent intervals. See **Group 25** of the *122SD and Coronado 132 Maintenance Manual* for intervals and procedures.



# 14

## Automated and Automatic Transmissions

---

|  |       |
|--|-------|
| Freightliner SmartShift Shift Control .....                | 14.1  |
| Eaton Fuller UltraShift PLUS Automated Transmissions ..... | 14.1  |
| Eaton Fuller UltraShift DM Automated Transmissions .....   | 14.5  |
| Eaton Fuller AutoShift Automated Transmissions .....       | 14.10 |
| Allison Automatic Transmissions .....                      | 14.13 |

# Automated and Automatic Transmissions

## Freightliner SmartShift Shift Control

### General Information, SmartShift

The SmartShift transmission control is an electronic transmission control device. It is installed with the following transmissions:

- Eaton Fuller UltraShift™ PLUS
- Eaton Fuller UltraShift™
- Eaton Fuller AutoShift™

It replaces the typical floor-mounted shift lever or dash-mounted push button control.

SmartShift accepts driver requests for transmission functions and transmits them through hard wiring to the transmission control unit (TCU). SmartShift is a true shift-by-wire system.

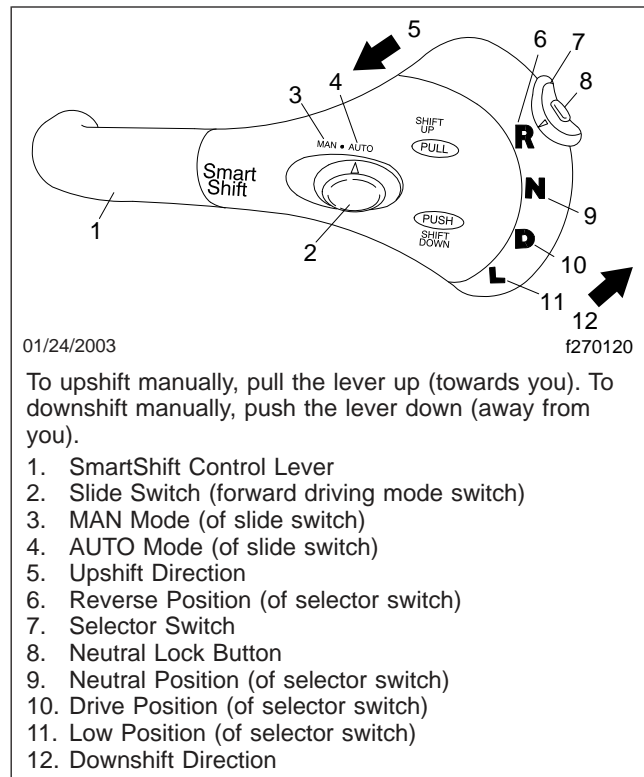
SmartShift offers two main advantages over conventional transmission control devices. Without a floor-mounted shift control, usable cab space is increased. The SmartShift control mounts to the right-hand side of the steering column and is operated by the fingers of the driver's right hand, allowing both hands to remain on the steering wheel.

A two-position slide switch is mounted on the body of the control lever just before the paddle widens out. The slide switch allows the driver to choose automatic (AUTO) or manual (MAN) mode. See [Fig. 14.1](#).

In AUTO mode, gears shift automatically, without driver interaction. Manual gearshifts are accomplished by a momentary pull or push on the control in the plane perpendicular to the steering wheel. Pull upward (toward you) on the control to upshift and push downward (away from you) to downshift. The control is spring-loaded and returns to mid-position when released after an upshift or downshift.

For Eaton Fuller UltraShift PLUS, UltraShift, and AutoShift transmissions, a four-position (R, N, D, L) selector switch is located at the end of the lever. See [Fig. 14.1](#).

Embedded in the selector switch is a small neutral lock button to prevent accidental shifts into gear from neutral. Any time you shift through N, press down on the neutral lock button to move the switch from neutral (N) to another gear, such as drive (D), low (L), or



To upshift manually, pull the lever up (towards you). To downshift manually, push the lever down (away from you).

1. SmartShift Control Lever
2. Slide Switch (forward driving mode switch)
3. MAN Mode (of slide switch)
4. AUTO Mode (of slide switch)
5. Upshift Direction
6. Reverse Position (of selector switch)
7. Selector Switch
8. Neutral Lock Button
9. Neutral Position (of selector switch)
10. Drive Position (of selector switch)
11. Low Position (of selector switch)
12. Downshift Direction

**Fig. 14.1, SmartShift Control (with Eaton Fuller UltraShift PLUS, UltraShift, and AutoShift)**

reverse (R). When shifting to N, it is not necessary to press the neutral lock button.

## Eaton Fuller UltraShift PLUS Automated Transmissions

Eaton Fuller UltraShift PLUS automated transmissions use shift selection software and electric clutch actuation; a clutch pedal is not needed to operate the vehicle. These transmissions use the four-position SmartShift control (see [Fig. 14.1](#)) on the steering column to select mode, direction, neutral, low, and to make manual shifts. To know what gear the transmission is in, see the current gear indicator on the dash. Forward shifts can be made either manually or automatically.

### Power Up

**NOTE:** Engine cranking is delayed until the transmission power-up is complete and the gear display shows a solid "N".

# Automated and Automatic Transmissions

---

1. With the parking brake set, turn the ignition switch to the ON position.
2. Start the engine.
3. Apply the service brake.

NOTE: If the service brake is not applied while selecting a starting gear, the initial start gear will not be found and the driver will need to select Neutral and press the service brake while selecting the desired mode.

4. Select the desired mode and starting gear. (Inappropriate start gear selections are ignored to avoid damaging the transmission.)
5. Release the parking brake.
6. Release the service brake and apply the accelerator.

## Power Down

1. Select Neutral on the shift control.

NOTE: If the gear display does not show a solid "N", neutral has not yet been obtained. Neutral should always be reached before powering down an UltraShift PLUS, except in cases of emergency.

2. Set the parking brake.
3. Turn off the ignition, and shut down the engine.

## Reverse (R)

NOTE: If attempting to select a non-Neutral mode without applying the service brakes, the transmission will not shift into gear. To shift into gear, select Neutral, apply the service brakes, and select the desired mode again. Also, the vehicle will not engage reverse above 2 mph (3 km/h).

Reverse (R) is at the upper end of the four-position selector switch located at the end of the SmartShift control. To select R, press in the neutral lock button and move the selector switch to the position above neutral. The default Reverse gear is engaged.

---

### NOTICE

---

**Avoid launching the vehicle in high range. Launching the vehicle in high range increases**

**the likelihood of clutch abuse and could be detrimental to clutch life.**

## Automatic Mode (AUTO)

In automatic drive mode (AUTO), upshifts and downshifts are made by the UltraShift PLUS without driver intervention. Press in the neutral lock button, move the selector switch to Drive (D), and press down on the throttle pedal. The transmission will shift automatically.

NOTE: If attempting to select a non-Neutral mode without applying the service brakes, the transmission will not shift into gear. To shift into gear, select Neutral, apply the service brakes, and select the desired mode again.

In Drive, the start gear is automatically selected. The selected start gear can vary depending on several vehicle inputs such as load, grade, and axle/transmission ratio. The start gear can be changed using the SmartShift control, provided the selected gear would allow the vehicle to launch without damaging the transmission. If the start gear is changed using the SmartShift control, it will be the default until the vehicle is powered down or the selection is changed again manually.

IMPORTANT: Prior to ascending a steep grade, either reduce the default start gear by one (using the SmartShift control) or apply full throttle for the duration of the grade so the vehicle maintains the proper engine and vehicle speed during the entire grade.

In Drive, the transmission automatically performs upshifts and downshifts. However, when the transmission is near the shift point, the shift can be forced using the upshift or downshift function of the SmartShift control.

NOTE: The transmission may deny a shift while ascending or descending a grade if the load of the vehicle and grade of the terrain in combination with the drivetrain ratio and engine torque fall outside of the acceptable range to perform a shift. If the shift is denied, a tone will sound.

## Manual Mode (MAN)

In manual mode (MAN), the driver selects upshifts and downshifts instead of letting the UltraShift PLUS select them automatically. Manual shifting may be

# Automated and Automatic Transmissions

---

helpful when traversing a work site, railroad tracks, or steep grades, for example. To drive forward, press in the neutral lock button, move the selector switch to Drive (D), and press down on the throttle pedal. To shift up, pull the lever up (towards you); to shift down, push the lever down (away from you). The system holds the current gear unless a shift is requested or if the system initiates a manual mode override.

**NOTE:** The transmission may deny a shift while ascending or descending a grade if the load of the vehicle and grade of the terrain in combination with the drivetrain ratio and engine torque fall outside of the acceptable range to perform a shift. If the shift is denied, a tone will sound.

**NOTE:** If attempting to select a non-Neutral mode without applying the service brakes, the transmission will not shift into gear. To shift into gear, select Neutral, apply the service brakes, and select the desired mode again.

## Manual Mode Override

The system is equipped with a manual mode override function. If the vehicle is being "back driven" (for example, descending a grade and vehicle speed exceeds engine speed) and the engine speed is excessively high, the system will upshift automatically. Also, if the start gear is changed and it causes the engine to lug at takeoff, the system will override the current position and select the best available gear.

## Low (L)

Low (L) is at the lower end of the four-position selector switch located at the end of the SmartShift control. Use Low when wanting to maximize engine braking and minimize the use of the brake pedal—for example, when driving down long grades or when coming to a stop. To select Low, press in the neutral lock button and move the selector switch to the L position. The lowest available start gear will be selected (the starting gear cannot be changed in Low).

If Low is selected while moving, the transmission will not upshift (unless the system initiates a Low override). The system will downshift at the earliest opportunity to provide maximum engine braking.

**NOTE:** If attempting to select a non-Neutral mode without applying the service brakes, the transmission will not shift into gear. To shift into

gear, select Neutral, apply the service brakes, and select the desired mode again.

## Low Override

The system is equipped with a Low override function. If the vehicle is being "back driven" (for example, descending a grade and vehicle speed exceeds engine speed) and the engine speed is excessively high, the system will upshift automatically. Also, if the start gear is changed and it causes the engine to lug at takeoff, the system will override the current position and upshift.

## Clutch Abuse Protection

Although a vehicle equipped with an UltraShift PLUS uses an automated clutch, the clutch can still overheat and slip with improper use. The clutch abuse protection feature helps protect the clutch if the automated clutch starts to overheat. When the clutch abuse protection feature initiates and sounds a warning tone, full clutch actuation must be completed quickly. If it is not completed quickly enough, the system will either open the clutch (if the throttle pedal is not being pressed) or close the clutch (if the throttle pedal is being pressed). If the abuse continues, the system will open the clutch and take away throttle control briefly to allow the clutch to cool down.

To protect the clutch:

- Select the lowest possible start gear for the application.
- Use Creep Mode when appropriate.
- Use the service brakes and the Hill Start Aid when launching on a grade.
- Minimize the time it takes to engage the clutch from rest.
- Do not use the throttle to hold the vehicle on a grade; use the service brakes.
- Do not use the throttle to stop roll back on an incline after Hill Start Aid disengages; use the service brakes, and then relaunch.
- Do not continually start and stop, especially when loaded; use a lower gear or Creep Mode.

## Creep Mode

The Creep Mode function allows the vehicle to maintain a constant speed at engine idle without the

# Automated and Automatic Transmissions

---

driver holding the throttle pedal position. This mode is useful for very low-speed maneuvering and applications where steady vehicle speed is required. The vehicle speed is determined by the selected gear ratio operating at governed low engine idle speed. Any available gear may be selected, though the transmission will downshift or exit Creep Mode to prevent stalling if the engine lugs due to load conditions.

By default, Creep Mode can be activated while in Manual Mode or Low. Eaton's ServiceRanger diagnostic software can be used to enable Creep Mode in Automatic Mode and/or Reverse.

## Engaging Creep Mode

To engage Creep Mode:

1. Select Low or Manual Mode and the desired gear (while stopped or moving).
2. Apply the throttle pedal to accelerate the vehicle until the clutch is closed (engaged).
3. Release the throttle pedal. The vehicle will continue moving at governed low engine idle speed.

## Exiting Creep Mode

To exit Creep Mode, apply the throttle pedal to accelerate temporarily, or select a higher gear in Manual Mode. (Creep Mode can be resumed in the selected gear by releasing the throttle pedal.)

**NOTE:** The transmission will exit Creep Mode if the engine lugs 150 rpm below the governed low engine idle speed. In this case, a lower gear should be selected if available.

## Hill Start Aid

UltraShift PLUS transmissions are equipped with a Hill Start Aid (HSA) feature to prevent the vehicle from rolling while on grades steeper than 3% and allow for a controlled launch. A grade sensor is used to determine when to engage the feature.

HSA is "on" by default. It can be turned off by pressing and releasing the override switch on the dash. HSA will turn back on after the first successful launch.

When the vehicle is stopped on a grade greater than 3% and in a forward mode or reverse, depress the service brakes then release them. The vehicle will begin to move after 3 seconds, and the clutch will

perform partial engagements to slow the vehicle motion. Either step on the brake or apply the throttle to continue negotiating the grade.

## Engine Overspeed Protection

The system will upshift if necessary to prevent engine overspeed in Drive, Manual, and Low.

## Shuttle Shifting

Shuttle shifting from reverse to any forward mode is only allowed if the vehicle speed is approximately zero.

## Auto Start Gear Selection and Override

The UltraShift PLUS system uses various inputs to automatically select the best start gear in Drive and Manual. This selection can be changed using the SmartShift control; however, if the selection requested could cause damage or engine lugging, the request will be denied and a tone will sound.

## Skip Shifting

When appropriate, the UltraShift PLUS system may skip shift in Drive. When prevailing conditions like load and grade allow, skip shifts can be performed in Manual mode using the SmartShift control.

## Auto Neutral

The UltraShift PLUS system will automatically shift to neutral if the vehicle is left in Drive and the parking brake is set. "AN" will show on the gear display. To re-engage the transmission, select Neutral and then either Drive or Reverse on the shift control (it will re-engage regardless of whether the parking brake is released).

## Automatic Traction Control

The UltraShift PLUS system requires the Automatic Traction Control (ATC) option to be enabled when driving in soft soil/sand to prevent wheel slippage and shifting issues. The ATC system has two modes: "normal" (for sand and loose road surface) and a mud/snow setting.

# Automated and Automatic Transmissions

## ATC Normal Mode

In normal mode, the system will engage the brakes on the wheel or side that the wheel slip is occurring to help the vehicle gain traction. The point at which the traction control will actuate the braking system increases with throttle: low throttle allows the system to brake the wheels earlier; heavy/full throttle raises the point of the acceptable wheel slip.

Adhere to the following points when driving in ATC normal mode:

- If using Automatic mode in soft soil and/or sand, maintain the engine speed between 1000 and 1300 rpm to prevent unnecessary upshifting.
- If using Manual mode in soft soil and/or sand, do not attempt an upshift and try to maintain the current gear.
- If the vehicle comes to a stop in the sand it may be necessary to back up prior to attempting forward movement.

## ATC Mud/Snow Mode

To select the mud/snow mode, depress the ATC switch (see [Chapter 5](#)). This mode raises the wheel slip speed that is allowed before the traction control activates. The point at which the traction control will actuate the braking system increases with throttle: low throttle allows the system to brake the wheels earlier; heavy/full throttle raises the point of the acceptable wheel slip.

## Load-Based Shifting

The UltraShift PLUS system is adaptive and will change the shift points based on grade, engine RPM, throttle position, and vehicle load. After changing loads or powering up, the system needs to relearn these inputs for the first few shifts to make the proper adjustments.

## Coasting

When coasting to a stop on level terrain, the UltraShift PLUS system may not downshift into the lower gears. It will select a gear after the throttle is applied.

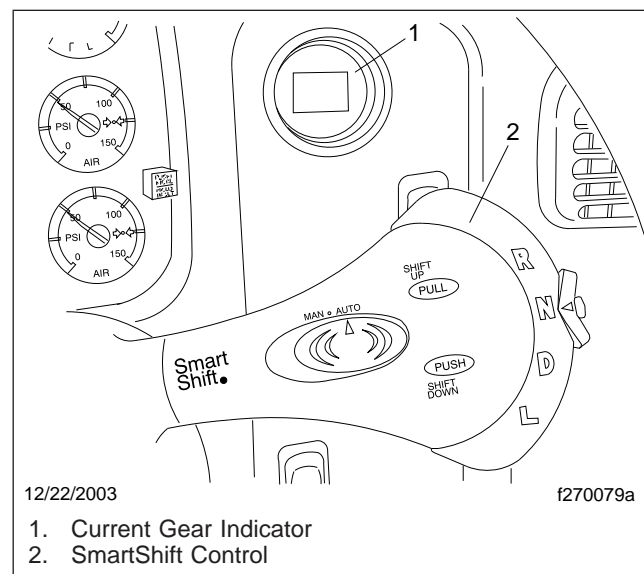
## Eaton Fuller UltraShift DM Automated Transmissions

### General Information, UltraShift DM

Eaton® Fuller® UltraShift™ DM is a heavy-duty fully automated transmission. No clutch pedal is required to operate the vehicle.

UltraShift DM uses a dry clutch system which is offered only on this automated transmission system.

The UltraShift transmission uses the four-position SmartShift lever on the steering column to select gears. The current gear is displayed on the indicator on the right-hand control panel as shown in [Fig. 14.2](#). All forward shifts can be made either manually or automatically, at the driver's choice.



**Fig. 14.2, Shift Controls and Indicators, UltraShift Transmissions**

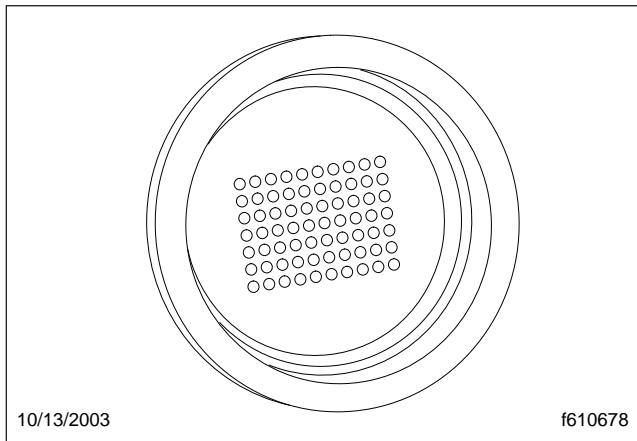
## Operation, UltraShift DM

### Power Up

1. With the parking brake set, select neutral (N) by moving the selector switch to the N position.
2. With the transmission in neutral, turn on the ignition switch. The CHECK TRANS and TRANS TEMP telltale lights come on and go out again (bulb check).

# Automated and Automatic Transmissions

3. After the ignition is turned on, the current gear indicator shows the dot display, arranged in a square pattern. All dots in the pattern should light up, without gaps or spaces. See [Fig. 14.3](#).



**Fig. 14.3, Power-Up Dot Display**

4. Wait for the current gear indicator to show a solid N. When the N is solid, rather than flashing, the UltraShift DM TCU is powered up. Apply the service brake and start the engine.
5. Select drive (D) by pressing in the neutral lock button and moving the selector switch downward to the position below neutral. Release the parking brake. The gear is displayed on the current gear indicator.

**NOTE:** When D is selected, the transmission controller starts up in second gear. If desired, the driver can select to start up in first. No other start gear is available.

6. On a level grade, release the service brake and press down on the throttle pedal to allow the vehicle to move forward. The vehicle will not move until the pedal is depressed.

## **WARNING**

**When starting or stopping on hills and grades, use extra care to prevent the vehicle from rolling back. A rollback accident could cause death, serious personal injury, or property damage.**

7. Prevent the vehicle from rolling backwards when stopped on a hill or grade, or when the vehicle is starting from a stop on a hill or grade.

- 7.1 *To start from a full stop on a hill or grade,* quickly move your foot from the brake pedal and press firmly on the throttle pedal.

On steep hills, set the parking brake, and release it only when there is enough engine power to prevent rollback.

- 7.2 *To stop on a hill or grade,* press and hold the brake pedal to keep the vehicle from moving.

On steep hills, set the parking brake. When parking, chock the tires, front and/or rear. Never hold a hill with the throttle pedal. This will cause the clutch to over-heat.

## Power Down

1. Apply the service brakes.
2. Select neutral (N) by pressing in the neutral lock button and moving the selector switch to N. When the N on the current gear indicator is solid, rather than flashing, the UltraShift DM TCU is ready to power down.
3. With the transmission in neutral, set the parking brake.
4. Turn off the ignition key and shut down the engine.

## Automatic and Manual Modes

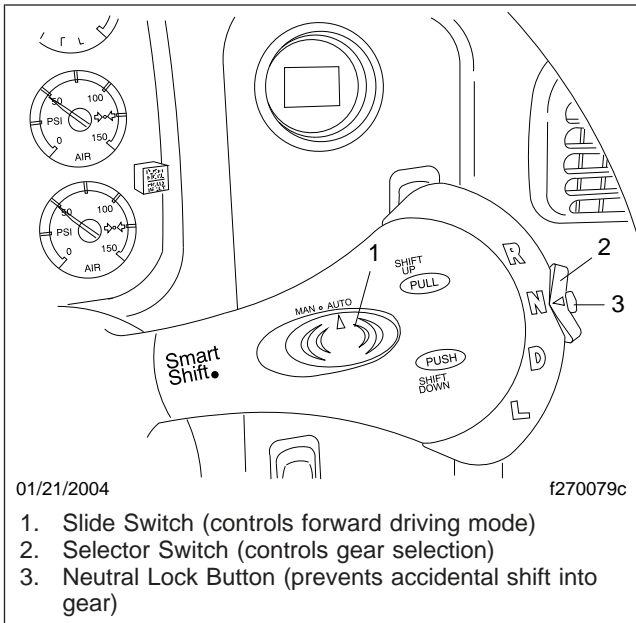
The SmartShift control has a slide switch located on the body of the control lever just before the paddle widens out. See [Fig. 14.4](#). The slide switch controls the forward driving mode, automatic or manual.

To change mode at any time, move the slide switch in the desired direction. This allows the driver to respond to a wide range of driving conditions, such as blind corners, tight curves, and steep hills.

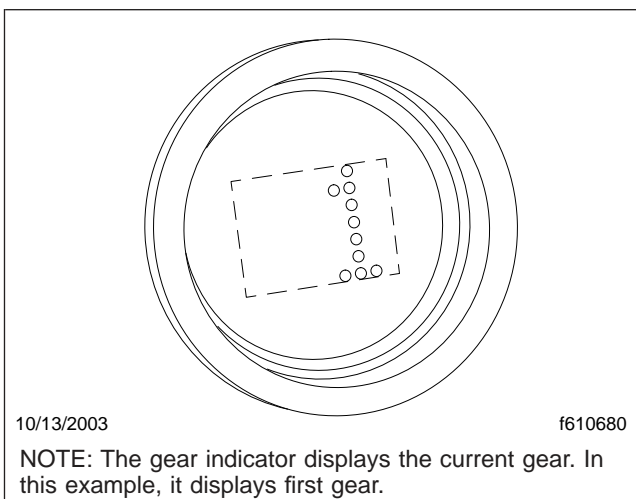
**IMPORTANT:** Whatever the mode, it is always possible to shift manually by moving the lever up or down as needed. When the engine speed is within 75 revolutions per minute (rpm) of the load-based shift point for an automatic shift, the UltraShift DM TCU will advance the shift.

In either mode, the gear indicator displays the current gear. See [Fig. 14.5](#).

# Automated and Automatic Transmissions



**Fig. 14.4, Switches, UltraShift Transmissions**



**Fig. 14.5, Current Gear Display**

At the start of a shift, the current gear continues to display until the transmission has been pulled into neutral. At this point, as the transmission is synchronizing for the new (target) gear, the gear indicator flashes the number of the new gear.

When the shift is complete, the new gear displays solid, without flashing.

## Automatic Mode (AUTO)

In automatic drive mode (AUTO), upshifts and downshifts are made by the transmission without driver intervention. Press in the neutral lock button, move the selector switch to drive (D), and press down on the throttle pedal. The transmission will shift automatically.

If driving conditions require, it is still possible to request a manual shift. The transmission will make the shift if the engine speed is within 75 rpm of the load-based shift point for that gear.

If the driver presses down on the throttle pedal after a manual downshift in automatic mode, the transmission will upshift again if the UltraShift DM TCU requires it.

## Manual Mode (MAN)

In manual drive mode (MAN), upshifts and downshifts are made by the driver:

- To shift up, pull the lever up (towards you).
- To shift down, push the lever down (away from you).

The system will hold the current gear until the driver requests a shift. In downhill situations in particular, the driver must be alert to vehicle speed by downshifting and/or using the service brakes as needed.

A shift request will still be refused if the selected gear would cause engine overspeed or excessive lugging.

## Selecting Gears

### Reverse

Reverse (R) is at the upper end of the four-position selector switch located at the end of the SmartShift control lever. To select R, press in the neutral lock button and move the selector switch upward to the position above neutral.

UltraShift DM has two reverse gears, reverse low and reverse high. To shift manually between them, use the shift lever as described for MAN mode. There is no AUTO mode for reverse.

When reverse low is selected, the letter R displays on the current gear indicator. When reverse high is selected, the letter H displays on the current gear indicator. See [Fig. 14.6](#).



# Automated and Automatic Transmissions

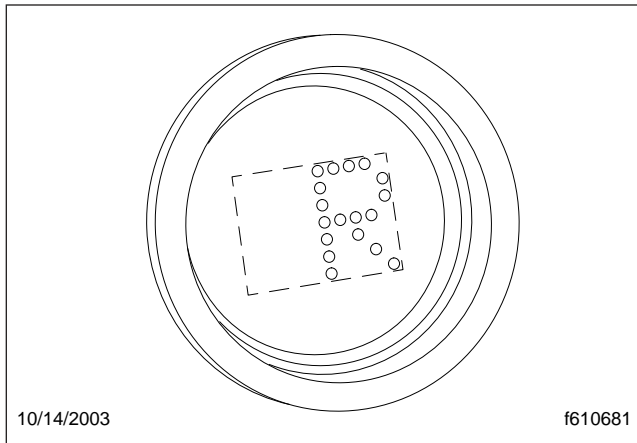


Fig. 14.6, Reverse Gear Display

**IMPORTANT:** Under normal conditions, do not select reverse with the vehicle moving forward.

The vehicle must be moving at less than two miles per hour (3 km/h) before selecting reverse. If reverse is selected when the vehicle is moving faster, an audible alert will sound and continue sounding at three-second intervals until the control lever is returned to the D position or the vehicle slows to the proper speed.

If necessary to rock the vehicle, use the selector switch to shift back and forth at low speed between reverse and drive.

## Neutral

**IMPORTANT:** Always start the engine with the transmission in neutral, the parking brake set, and the service brakes applied.

Neutral (N) is directly below R on the four-position selector switch located at the end of the SmartShift control lever. To select N, press in the neutral lock button and move the selector switch to the position below R. When neutral is selected, the letter N displays on the current gear indicator. See [Fig. 14.7](#).



**Do not coast in neutral. Coasting in neutral can cause an accident, possibly resulting in severe personal injury or death.**

Neutral is always available during operation, whatever the vehicle speed. When in neutral, requests to

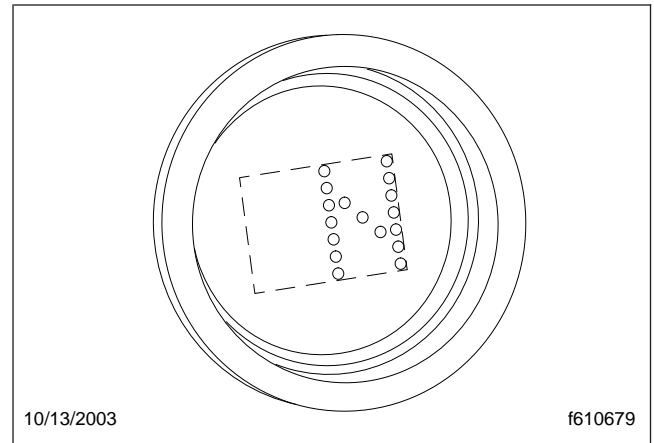


Fig. 14.7, Neutral Display

upshift or downshift are ignored. If the selector switch is moved from neutral to drive while the vehicle is moving, the transmission will shift into a gear within the engine's operating speed range.

When shifting from neutral, always press on the brake pedal. If the brake pedal is not pressed, the transmission will not shift, the current gear display will flash N, and an audible alert will sound.

**NOTE:** To reset the transmission, return the selector switch on the SmartShift lever to N and attempt the shift again, this time with the brake pedal pressed.

Before shutting down the engine, return the selector switch to N. When the ignition is turned off, the transmission will reset to neutral in a few minutes regardless of the position of the shift lever.

## Drive

Drive (D) is directly below N on the four-position selector switch located at the end of the SmartShift control lever. To select D, press in the neutral lock button and move the selector switch to the position below N. When drive is selected, the number of the currently selected forward gear displays on the gear indicator. See [Fig. 14.5](#).

When in drive, requests to upshift or downshift are enabled. Either manual or automatic mode can be selected on the slide switch.

Two starting gears are available, first and second. The default starting gear is second, but first can be

# Automated and Automatic Transmissions

---

selected by the driver, if desired. To change the starting gear, press the brake pedal and select D with the vehicle stopped. The current gear indicator will display the starting gear. Move the shift lever up or down until the desired starting gear is displayed.

The UltraShift DM TCU adapts to the working conditions of each vehicle and its driver. After power up or a load change, it needs to learn the new conditions. While learning, it may hold a gear too long before upshifting. Start the upshift manually. It may take three or four shifts before UltraShift succeeds in learning the new load-based shift points, but after that it will handle the shifting automatically.

## Low

Low (L) is at the lower end of the four-position selector switch located at the end of the SmartShift control lever. To select L, press in the neutral lock button and move the selector switch to the position below D.

When in low, the current gear is maintained. Requests to upshift are not enabled.

**IMPORTANT:** If the engine is approaching overspeed, the UltraShift DM TCU will override the current gear setting and upshift to prevent engine damage.

To enhance engine braking, downshifts are performed at higher rpm than normal.

If L is selected from neutral while stopped, the vehicle starts up in first gear and stays there until the engine approaches overspeed.

## Upshifting

To request an upshift with the transmission in drive, pull the control lever up (towards you). If the gear is available, the transmission upshifts and the new gear displays on the gear indicator. No skip shifts are available while upshifting.

No upshifts are available in low, except to prevent engine overspeed.

If the transmission does not upshift quickly enough after power-up or a load change, begin the shift manually. The UltraShift DM TCU will learn the new load-based shift conditions after three or four shifts.

If the gear requested is unavailable, a tone will sound. An unavailable request to upshift is not stored in memory. The upshift must be requested again.

## Downshifting

**NOTE:** The driver can manually downshift at any time, even when the slide switch is set to AUTO mode.

To request a downshift with the transmission in drive or low, push the control lever down (away from you). If the gear is available, the transmission downshifts and the new gear displays on the gear indicator. Skip shifts are available while downshifting.

For best engine braking, select low while moving. In low, downshifts are performed at higher rpm than in drive.

**IMPORTANT:** If the engine is approaching overspeed, the UltraShift DM TCU will override the current gear setting and upshift to prevent engine damage.

If the gear requested is unavailable, a tone will sound. An unavailable request to downshift is not stored in memory. The downshift must be requested again.

When coasting to a stop, the UltraShift DM TCU may not finish the downshift until the driver presses down on the throttle pedal again.

**IMPORTANT:** A downshift request can never result in a shift into neutral, even if the vehicle is in the drive position in the lowest possible gear.

Before starting down a hill, slow down. Downshift to a speed that you can control without hard pressure on the service brakes.

Before entering a curve, slow down to a safe speed. Downshift if necessary. This lets you use some power through the curve to help the vehicle be more stable on the turn. It also allows you to regain speed faster as you come out of the curve.

## Ultrashift Diagnostics

### Clutch Protection Fault

Excessive clutch slippage creates heat and reduces the life of the clutch. These are some conditions which lead to clutch abuse:

- Using the throttle to hold the vehicle on a grade
- Starting the vehicle in too high a gear

# Automated and Automatic Transmissions

---

- Overloading the vehicle
- Using high idle with the vehicle in gear

The UltraShift DM TCU is programmed to prevent clutch abuse. When the clutch overheats, the following alerts take place:

- The TRANS TEMP light comes on
- The current gear indicator displays CA
- A warning tone sounds at one-second intervals

The alerts continue until the clutch cools, the throttle is released, or the clutch is fully engaged.

## System Problem

In the event of a problem, do the following steps.

1. Note the driving conditions at the time the problem occurred.
2. Record the status of the transmission at the time of the problem (AUTO or MAN mode, gear setting R, N, D, or L, current gear, engine speed, etc.)

## Locked In Gear

If the transmission becomes locked in gear, a dash (–) will appear on the current gear indicator when the vehicle is restarted during the reset procedure.

**NOTE:** If the transmission becomes locked in gear while the vehicle is moving, increased braking effort may be required to stop the vehicle.

If the current gear indicator displays a dash during power-up with the selector switch in neutral, do the following steps.

1. Make sure the parking brake is set.
2. Turn off the ignition and wait at least two minutes.
3. Apply the service brakes.
4. With the service brakes applied, release the parking brake.
5. Make sure the selector switch is in neutral and turn on the ignition key. Do not attempt to start the engine at this time.

6. If necessary to get the transmission to shift into neutral, release the pressure on the brake pedal slightly.
7. Once the UltraShift DM TCU reaches neutral, a solid N will appear on the current gear indicator and the vehicle will start. Make sure the service brakes are applied and the parking brake is set.

If the current gear indicator continues to display a dash, contact an authorized Freightliner or Eaton service facility.

## Reset Procedure

Transmission operation can sometimes be restored by doing the following reset procedure:

1. Stop the vehicle when it is safe to do so. Set the parking brake.
2. Place the selector switch in neutral and turn off the ignition.
3. Check all transmission harness connectors.
4. Wait at least two minutes with the engine shut down.
5. Restart the engine.

If the problem continues, contact an authorized Freightliner or Eaton service facility.

## Eaton Fuller AutoShift Automated Transmissions

Refer to the Eaton website for additional information, [www.roadranger.com](http://www.roadranger.com).

## General Information, AutoShift

### RT/RTO Models

Eaton Fuller AutoShift transmissions have 10 or 18 forward speeds and two reverse speeds. The driver must use the clutch to start and stop the vehicle.

The driver does not need to break torque or increase or decrease engine speed to synchronize the shift. The transmission signals the engine controller when to break torque and the engine controller automatically increases or decreases engine speed. When engine speed is correct, the transmission engages the next gear and signals the engine controller to resume operation.

# Automated and Automatic Transmissions

The AutoShift system consists of the following components:

- The SmartShift control paddle on the steering column. See [Fig. 14.1](#).
- The gear display module mounted on the dashboard indicates the current gear position or transmission status. The display also flashes the next gear to be engaged while the transmission is in neutral during a gear change. See [Fig. 14.8](#).
- The shifter mechanism performs shifts at the front portion of the transmission. It preselects the shift to neutral and completes the gear change after driver input.
- The Electronic Control Unit (ECU) includes two controllers: a transmission ECU and a system ECU. The transmission ECU controls all transmission shift functions and the system ECU manages all vehicle interfaces for transmission shift functions.
- An electronic range valve, controlled by the transmission ECU, is used to perform range shifts.

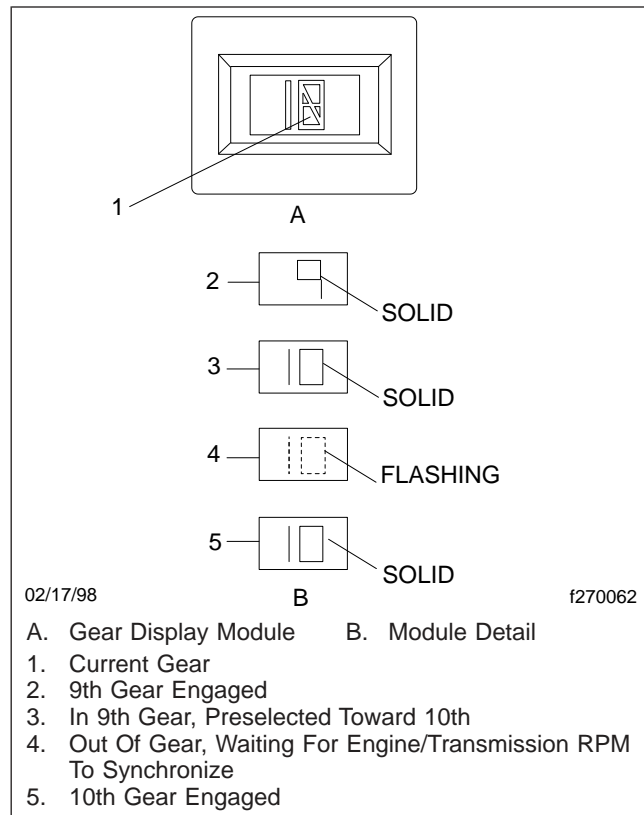
## Operation, AutoShift with SmartShift Automatic and Manual Modes

A two-position slide switch (forward driving mode switch) is located near the end of the SmartShift control. See [Fig. 14.1](#). The switch positions are labelled MAN (manual shift mode) and AUTO (automatic drive mode).

**NOTE:** In automatic drive mode, upshifts and downshifts require no driver interaction. Move the selector switch to the drive (D) position, disengage the clutch to engage the gear selected, engage the clutch and drive the vehicle. In manual shift mode, upshifts and downshifts require either a pull upward or push downward on the control.

### Driver Message Center

Gear information is presented to the driver via a LCD display on the dash. In automatic drive mode, the number of the forward gear currently engaged appears continually on the message display screen when in drive (D). In manual shift mode, the current



**Fig. 14.8, Gear Display Module**

gear is displayed until a new gear is requested. When neutral (N) is engaged, "N" will appear on the message display screen. When reverse (R) is engaged, either "RL" or "RH" will appear on the message display screen.

**IMPORTANT:** The information shown on the message display screen indicates the state of the transmission only, not the state of the SmartShift control.

### Neutral Position

Select neutral by sliding the selector switch to the "N" position.

**NOTE:** Neutral is always available during operation. When in neutral, upshift and downshift requests are ignored. If the mode selector switch is moved from neutral (N) to drive (D) while the vehicle is moving, the transmission will shift into a gear causing the engine to go to a high torque level, under the engine's rated torque.

# Automated and Automatic Transmissions

---

## Selecting a Starting Gear

1. In automatic mode, select drive (D) by sliding the selector switch downward to the next position below the neutral position.
2. Disengage the clutch to engage the gear selected. Engage the clutch and drive the vehicle.

## Changing the Default Starting Gear

To select a starting gear other than the default starting gear, follow the instructions below.

1. Make sure the vehicle is stopped and in drive.
2. In either automatic or manual mode, pull upward on the control (to increase), or push downward (to decrease). Each pull upward on the control increases the starting gear by one gear, but no higher than fourth gear.
3. The number of the gear selected will flash on the message display screen until the driver engages the clutch. This gear will be stored in memory as the default starting gear until either a different starting gear is selected by the driver or the engine is shut down.

**NOTE:** The transmission may also be programmed so that it is not possible to select a starting gear other than the preprogrammed default starting gear.

## Upshifting

**NOTE:** With the transmission in drive (D) in the automatic mode, upshifts require no driver interaction.

1. With the transmission in drive in the manual mode, request an upshift by pulling upward on the control. If the requested gear is available, the transmission will upshift.

**NOTE:** A single, momentary pull upward on the control selects the next higher gear when it is available. Two consecutive, momentary upward pulls will cause a skip shift when the next two higher gears are available and conditions are right.

2. To skip shift, move the control two times in less than 1/2 second. The number of the gear engaged will appear on the message display screen.

**NOTE:** The Eaton Fuller AutoShift transmission is able to perform triple upshifts when the next three higher gears are available and conditions are right. To triple-shift this transmission, move the control three times in less than 1/2 second.

If a requested gear is not available, an audible warning will sound and the gear display module will indicate that the gear is not available. An unavailable requested upshift is not stored in memory. The upshift must be requested again.

## Downshifting

**NOTE:** With the transmission in drive (D) in the automatic mode, downshifts require no driver interaction.

1. With the transmission in drive in the manual mode, request a downshift by pushing downward on the control. If the requested gear is available, the transmission will downshift.

**NOTE:** A single, momentary push downward on the control selects the next lower gear when it is available. Two consecutive, momentary downward pushes will cause a skip shift, when the next two lower gears are available and conditions are right.

2. To skip shift, move the control two times in less than 1/2 second. The number of the gear engaged will appear on the message display screen.

**NOTE:** The Eaton Fuller AutoShift transmission is able to perform triple downshifts when the next three lower gears are available and conditions are right. To triple shift this transmission, move the control three times in less than 1/2 second.

If a requested gear is not available, an audible warning will sound and the gear display module will indicate that the requested gear is not available. Unlike upshifting, an unavailable requested downshift is stored in memory and the shift will be made when the gear is available. The time limit for this memory is a programmable parameter.

# Automated and Automatic Transmissions

## Start-Up

1. With the parking brake applied, press the clutch all the way down to the floor.
2. Start the engine.
3. Check to make sure the transmission is in neutral.
4. With the transmission in neutral, release the clutch.

NOTE: This allows the speed sensor on the input shaft to get a reading.

5. Press down on the clutch again and release the parking brake.
6. Select the desired starting gear.
7. Release the clutch.

## Reverse

1. To engage reverse (R), slide the selector switch upward to the next position above the neutral position and disengage the clutch.

NOTE: AutoShift transmissions have a dual-range reverse. Reverse low (RL) is the default reverse gear.

2. Select reverse high (RH) by pulling upward on the control.

NOTE: Reverse may be engaged below a programmable forward speed in order to rock the vehicle. If reverse is selected above the programmed forward speed, an audible warning will sound and a message indicating that the gear is not available will appear on the message display screen.

## Low Gear Operation

Use low (L) when descending steep hills and using compression braking. Engine speed will be increased by 200 rpm and shift points will be offset by 200 rpm. The efficiency of the exhaust brake will be maximized.

## Using the Clutch

Use the clutch to start and stop the vehicle.

## Allison Automatic Transmissions

Refer to the Allison website for additional information, [www.allisontransmission.com](http://www.allisontransmission.com).

## General Information, Allison

HD-series automatic transmissions have six forward speeds and one reverse speed. See [Fig. 14.9](#). These transmissions have electronic shift controls that can be programmed to allow the use of different numbers of geared speeds. For instance, the transmission can be programmed to operate as a 4-speed, 5-speed, or 6-speed unit in the "primary" shift mode. If needed, a "secondary" shift mode can be programmed to provide another shift configuration to optimize vehicle use under different operating conditions. To activate a secondary shift mode, or other special function programmed into the electronic control unit (ECU), depress the Mode button. "Mode On" is displayed in the indicator panel just above the push buttons. A label just above the Mode button identifies the special function.

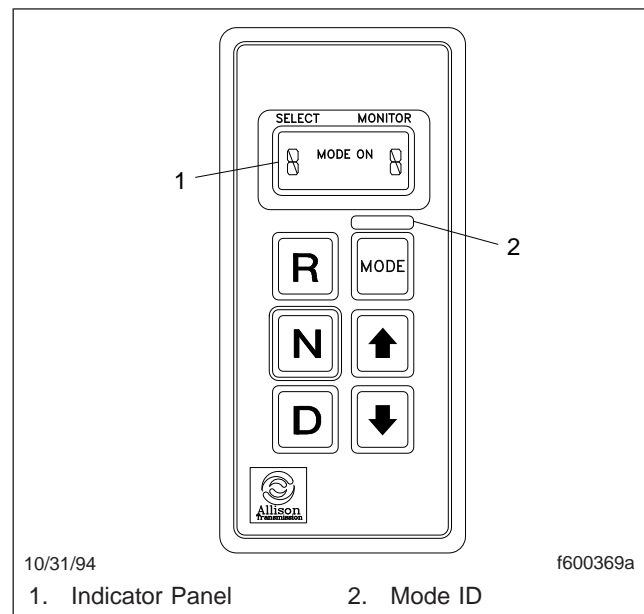


Fig. 14.9, Allison Push Button Shift Selector

NOTE: Each time a push button is depressed on the shift selector, a short beep will be heard. This indicates that the ECU has received input to change operation.

# Automated and Automatic Transmissions

---

## Operation Tips, Allison

 **WARNING**

**Never shift from neutral (N) to drive (D) or reverse (R) at engine speeds above idle. The vehicle will lurch forward or backward, which could cause property damage and personal injury.**

---

### NOTICE

---

**The engine should never be operated for more than 30 seconds at full throttle with the transmission in gear and the output stalled. Prolonged operation of this type will overheat the transmission fluid and will result in severe damage to the transmission.**

---

### NOTICE

---

**Do not allow the vehicle to coast in neutral. This can result in severe transmission damage. Also, no engine braking is available.**

The following tips highlight important operation principles.

- Start the engine, then check the digital display on the "push button shift selector." Under "Select" at the top of the unit, the display should always show the "primary" shift mode. Under "Monitor," the gear the transmission is in should be displayed.
- Use reverse (R) to back the vehicle. Completely stop the vehicle before shifting from a forward gear to reverse, or from reverse to forward. There is only one reverse gear.
- Select drive (D) for all normal driving conditions. The vehicle will start out in 1st gear, and as speed increases, the transmission will upshift through each gear automatically. As the vehicle slows down, the transmission will downshift to the correct gear automatically.
- The pressure of your foot on the accelerator pedal influences the automatic shifting. When the pedal is fully depressed, the transmission will automatically upshift near the governed speed of the engine. A partially depressed position of the pedal will cause the upshifts to occur at a lower engine speed.

- Occasionally the road, load, or traffic conditions make it desirable to restrict the automatic shifting to a lower range. The lower the gear range, the greater the engine braking power.
- Use the up or down arrow buttons on the shift selector to reach the desired gear. The "Select" indicator will display your choice, and the "Monitor" indicator will show the selected gear once it is reached. In the lower gear ranges, the transmission will not upshift above the highest gear selected unless the engine governed speed is exceeded.
- Use neutral (N) and apply the parking brake when the vehicle is parked with the engine running.

# 15

## Drive Axles

---

|  |      |
|--|------|
| Drive Axles with Differential Lock ..... | 15.1 |
|--|------|



# Drive Axles

## Drive Axles with Differential Lock

### Drive Axles with Main Differential Lock

The main differential lock is a driver-controlled traction device operated from the vehicle cab. A dash switch controls the side to side lock-up of the rear axle, supplying equal traction to both sides. On tandem axles there are three possible differential lock options:

- Forward-rear carrier only
- Rear-rear carrier only
- Both rear carriers.

An indicator light comes on when the differential lock is engaged. An optional buzzer can also be used to indicate differential lock engagement.

The main differential lock provides maximum traction under slippery conditions. When the differential lock is engaged, the clutch collar completely locks the differential case, gearing, and axle shafts together, maximizing traction of both wheels and protecting against spinout. Under normal traction conditions, do not engage the differential lock. Operate the axle with differential action between both wheels.

### **WARNING**

**Be especially careful when driving under slippery conditions with the differential locked. Though forward traction is improved, the vehicle can still slip sideways, causing possible loss of vehicle control, personal injury, and property damage.**

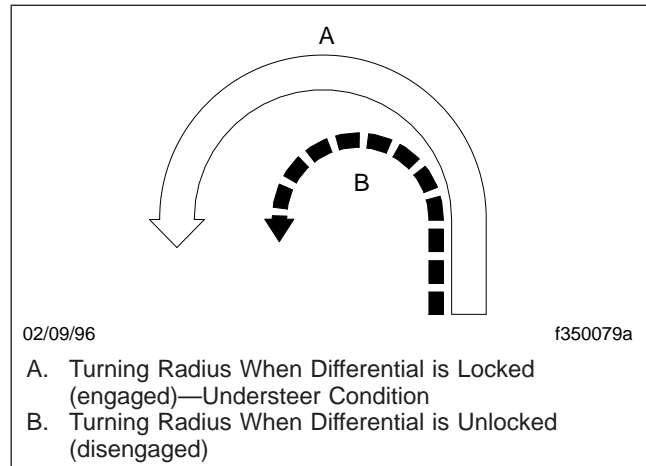
### Main Differential Lock Operation

To lock the main differential and obtain maximum traction under slippery conditions, move the control switch to the lock position.

**NOTE:** On some vehicles, the differential lock system is connected through the low speed range of the transmission. If this system is used, the transmission must be in the low speed range for the differential to fully lock.

If the vehicle is moving, maintain a constant vehicle speed while engaging the differential lock. Briefly let up on the accelerator to relieve torque on the gear-

ing, allowing the differential to fully lock. The indicator light should come on and the buzzer should sound on vehicles so equipped. When the differential is fully locked, the turning radius will increase because the vehicle understeers. See [Fig. 15.1](#). Drive cautiously and do not exceed 25 mph (40 km/h).



**Fig. 15.1, Turning Radius**

To unlock the main differential, move the control switch to the unlock position. Briefly let up on the accelerator to relieve torque on the gearing, allowing the differential to fully unlock.

**NOTE:** If the differential lock system is connected through the low speed range of the transmission, shifting out of low speed range will also unlock the differential.

When the differential lock disengages, the indicator light will go off and the buzzer will stop.

### Tandem Drive Axles with Interaxle Differential

Tandem drive axles with an interaxle differential have a lockout feature. Differential lockout is controlled by a switch ([Fig. 15.2](#)) on the control panel.

In the UNLOCK position, there is differential action between the two axles. The differential compensates for different wheel speeds and variations in tire size. Keep the interaxle differential unlocked for normal driving on roads where traction is good.

In the LOCK position, the interaxle differential is locked out and the driveshaft becomes a solid connection between the two axles. Power entering the

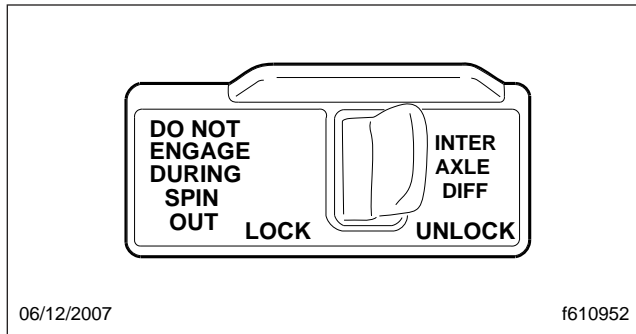


Fig. 15.2, Interaxle Differential Control

forward axle is also transmitted straight through to the rear axle, so both axles turn together at the same speed. The LOCK position should be used when the vehicle encounters poor traction conditions; however, it also increases drivetrain and tire wear and should be used only when improved traction is required.

### Interaxle Differential Lockout Operation

To lock the interaxle differential and achieve maximum pulling power when approaching slippery or poor road conditions, move the lockout control valve to LOCK while maintaining vehicle speed, before encountering the poor road conditions. Let up momentarily on the accelerator to engage the differential lock. Proceed over poor road conditions with caution. Do not wait until traction is lost and the tires are spinning before locking the interaxle differential.

### NOTICE

**Do not actuate the interaxle differential control valve while the tires are slipping. Do not operate the vehicle continuously with the interaxle differential locked during extended good road conditions. To do so could result in damage to the axle gearing and excessive tire wear.**

To unlock the interaxle differential, move the lockout control valve to UNLOCK while maintaining vehicle speed, after leaving the poor road conditions. Let up momentarily on the accelerator to allow the shift, then resume driving at normal speed.

### Single Drive Axles with Traction Equalizer

Some single drive axles are equipped with a traction equalizer that is a load-sensing, self-actuating fea-

ture. A traction equalizer provides normal differential action where traction is good. When one wheel begins to spin faster than the other, clutch plates in the differential housing automatically engage, delivering power to both wheels. There is no operator control with this feature.

### NOTICE

**Tire sizes on both rear wheels should be the same on axles equipped with a traction equalizer. If not, excessive wear may occur in the traction equalizer.**

# 16

## Steering System

---

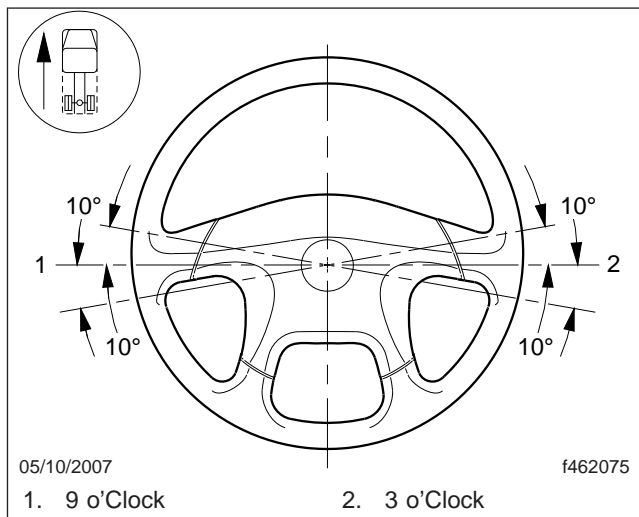
|                             |      |
|-----------------------------|------|
| Power Steering System ..... | 16.1 |
|-----------------------------|------|

# Steering System

## Power Steering System

The steering gear system includes the power steering gear, hydraulic hoses, power steering pump, reservoir, and other components. Some models are also equipped with a separate hydraulic power cylinder on the right side of the front axle, or a right-hand slave gear (such as the TRW RCH-45). The power steering pump, driven by the engine, provides the power assist for the steering system. If the engine is not running, there is no power assist. If the power-assist feature does not work due to hydraulic fluid loss, steering pump damage, or some other cause, bring the vehicle to a safe stop. Do not drive the vehicle until the cause of the problem has been corrected.

When there is no load on the vehicle, and the front tires are pointed straight ahead, the steering wheel spokes should be centered,  $\pm 10$  degrees, as shown in [Fig. 16.1](#). See **Group 46** of the *122SD and Coronado Workshop Manual* for steering adjustment procedures.



**Fig. 16.1, Proper Steering Wheel Position (with tires pointed straight ahead)**

### **WARNING**

Driving the vehicle without the power-assist feature of the steering system requires much greater effort, especially in sharp turns or at low speeds, which could result in an accident and possible injury.

### **NOTICE**

**Never steam clean or high-pressure wash the steering gear. Internal damage to gear seals, and ultimately the steering gear, can result.**

Drivers should carefully use the power available with a power steering system. If the front tires become lodged in a deep chuckhole or rut, drive the vehicle out, instead of using the steering system to lift the tires from the hole. Also, avoid turning the tires when they are against a curb, as this places a heavy load on steering components and could damage them.

# 17

## Fifth Wheels

---

|   |      |
|---|------|
| Fifth Wheels, General Information ..... | 17.1 |
| Fifth Wheel Coupling .....              | 17.1 |
| Fifth Wheel Uncoupling .....            | 17.4 |
| Fifth Wheel Slide .....                 | 17.7 |

# Fifth Wheels

## Fifth Wheels, General Information

### WARNING

Do not use any fifth wheel that fails to operate properly. Doing so may cause loss of vehicle control, possibly resulting in severe personal injury or death.

## Air-Suspension Dump Valve

The air-suspension dump valve may be used to adjust the tractor height to aid with coupling to or uncoupling from a trailer. See [Fig. 17.1](#). When the switch is set to LOWER, the air-suspension dump valve deflates the air springs to lower the rear of the vehicle. In the AUTO position, the automatic ride-control valves operate for normal driving.

### WARNING

Never exhaust air from the suspension while driving. The suspension will not absorb road shocks, possibly damaging components, and vehicle handling may be compromised. This could result in loss of vehicle control, possibly resulting in severe personal injury or death.

### NOTICE

Do not operate the vehicle over uneven ground such as ramps, speed bumps, curbs, etc. with the air springs deflated. Doing this may lead to air bag separation from the piston, preventing the suspension air springs from inflating.

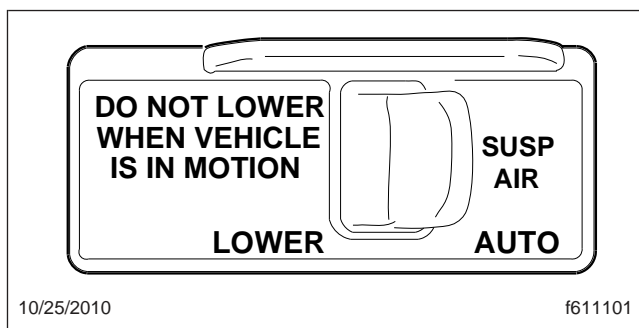


Fig. 17.1, Air-Suspension Dump Valve

## Fifth Wheel Lubrication

### WARNING

Keep the fifth wheel plate lubricated to prevent binding between the tractor and trailer. A binding fifth wheel could cause erratic steering and loss of vehicle control, possibly resulting in personal injury or death.

The standard fifth wheel plate must be kept well lubricated with chassis grease to prevent friction and binding between the tractor fifth wheel plate and the trailer.

For a low-lube fifth wheel plate, inspect the condition of the low-lube pads. There should be no damaged or missing pieces. Slight puckering at the outside edges is normal.

For lubrication instructions, see **Group 31** of the *122SD and Coronado 132 Maintenance Manual*.

## Fifth Wheel Coupling

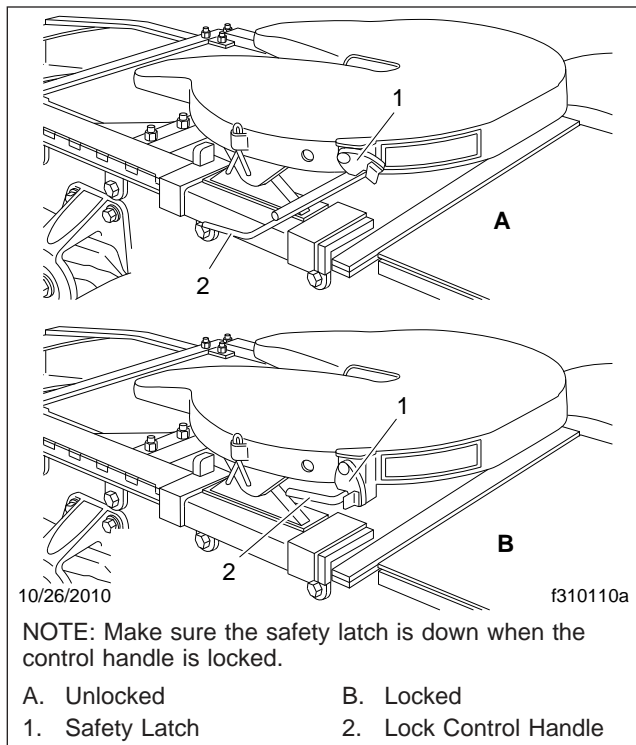
Fifth wheel coupling is activated with the lock control handle located on either the right side or left side of the fifth wheel. Coupling has successfully occurred when the kingpin has been forced into the jaws and the lock control handle has moved to the locked position.

### NOTICE

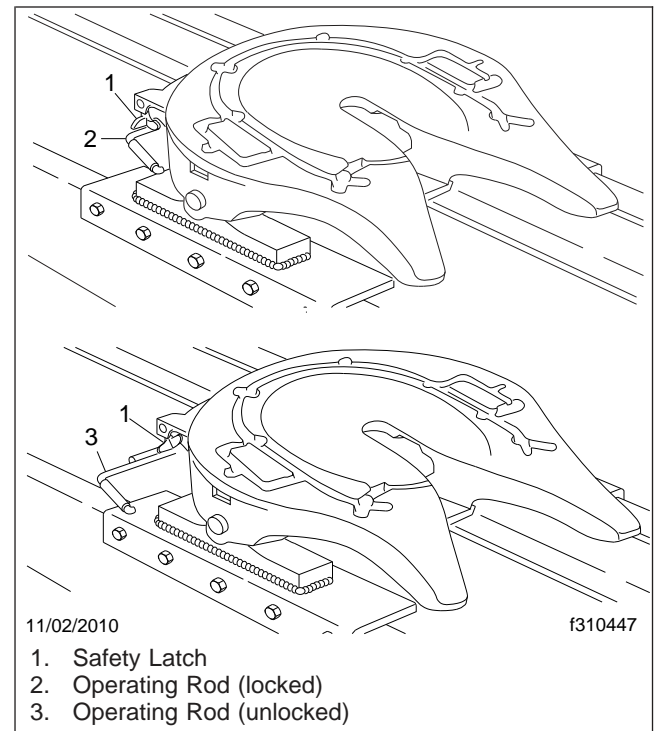
Some fifth wheels may be mounted on sliding rails. Before attempting to couple a trailer to a sliding fifth wheel, the slide feature must be locked to prevent the top plate from sliding rapidly forward or rearward, causing damage to the fifth wheel or kingpin.

## Fontaine and Holland Fifth Wheels Coupling

1. Chock the front and rear of the trailer tires to prevent the trailer from moving.
2. Ensure the fifth wheel jaw is fully open and the operating rod is in the unlocked position. See [Fig. 17.2](#) or [Fig. 17.3](#).
3. Make sure the fifth wheel top plate is tilted so the ramps are as low as possible.



**Fig. 17.2, Fontaine Locking Mechanism**



**Fig. 17.3, Holland Simplex SE Locking Mechanism**

- Position the tractor so that the center of the fifth wheel is in line with the trailer kingpin. The kingpin should be in a position to enter the throat of the locking mechanism.

## NOTICE

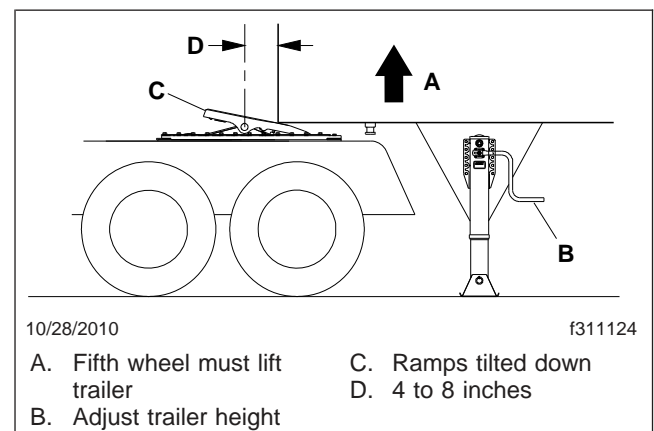
Attempting to couple at the wrong height may cause improper coupling, which could result in damage to the fifth wheel or kingpin.

- Adjust the trailer height if required.

**For a standard fifth wheel plate**, the trailer should contact the fifth wheel approximately 4 to 8 inches (10 to 20 cm) behind the fifth wheel pivot. See [Fig. 17.4](#).

**For a low-lube fifth wheel plate**, the fifth wheel must slide freely under the trailer, and the trailer should contact the fifth wheel at the pivot. See [Fig. 17.5](#).

- With the fifth wheel lock opening aligned with the trailer kingpin, back the tractor slowly toward the trailer. After sliding under the trailer, STOP to



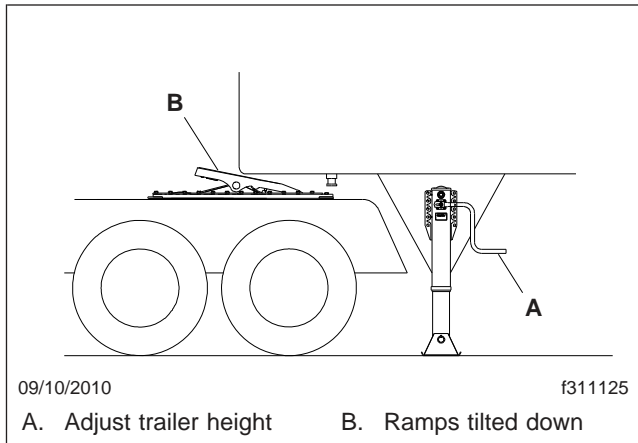
**Fig. 17.4, Trailer Connection Point, Standard Fifth Wheel**

prevent from hitting the kingpin too hard, then resume backing slowly until the fifth wheel locks.

On a standard fifth wheel, the fifth wheel must lift the trailer.

On a low-lube fifth wheel, do not lift the trailer as this may damage the fifth wheel plate.

# Fifth Wheels



**Fig. 17.5, Trailer Connection Point, Low-Lube Fifth Wheel**

7. Apply the tractor parking brakes.

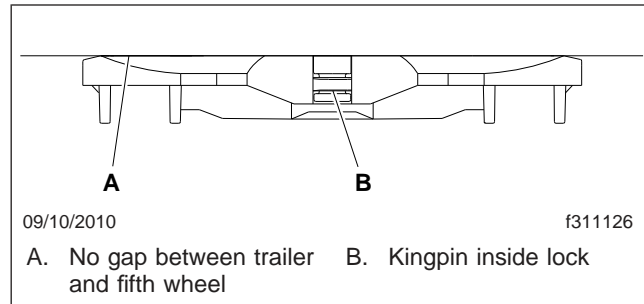
## **WARNING**

A visual inspection is required by law. Some improper couplings can pass a pull test. Sound is not reliable. Get out of the cab and look. Incorrect coupling could cause the trailer to disconnect, possibly resulting in serious personal injury or death.

8. Perform a coupling inspection, checking that there is no gap between the bottom of the trailer and the fifth wheel, and that the kingpin is securely locked. See [Fig. 17.6](#)

When lockup has occurred, the fifth wheel control handle moves to the locked position. Make sure that the safety latch is down over the lock control handle to hold the control handle in the locked position. (The safety latch will only rotate down if the operating rod is fully retracted in the locked position.) See [Fig. 17.2](#) for Fontaine fifth wheels. See [Fig. 17.3](#) for Holland fifth wheels.

9. Release the tractor parking brakes. Test for kingpin lockup slowly inching the tractor forward, pulling on the trailer against the chocks.
10. After lockup is completed, connect the tractor-to-trailer air system lines and the electrical cable to the trailer. Take care to prevent dirt or foreign material from entering the air system lines.



**Fig. 17.6, Coupling Inspection**

## **NOTICE**

Always make sure the connection hanger keeps the trailer air hoses and electrical cables positioned so that they do not rub on anything. Rubbing may wear through hoses or cables, resulting in air leaks, or exposed or broken wires, potentially affecting trailer brake or electrical systems.

11. Charge the air brake system with air, checking that the air connections do not leak.

## **WARNING**

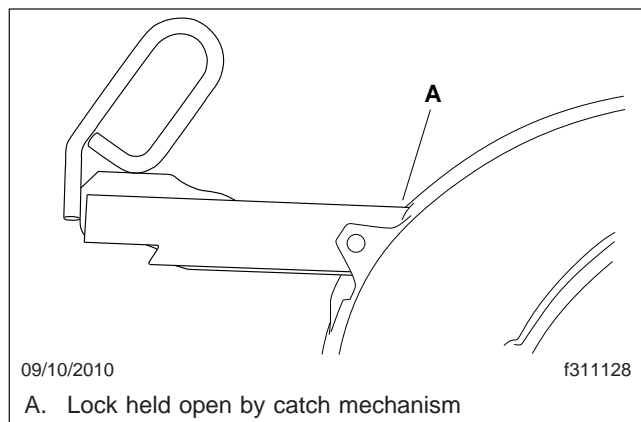
Incorrect fifth wheel lock adjustment could cause the trailer to disconnect, possibly resulting in serious personal injury or death.

12. With the trailer wheels chocked and the brakes set, check for clearance between the kingpin and the fifth wheel jaws by moving the tractor forward and backward against the locked kingpin. If slack is present, uncouple the trailer and have the fifth wheel inspected and adjusted by a certified technician.

## Jost Fifth Wheel Coupling

1. Tilt the ramp down.
2. Open the kingpin locks. See [Fig. 17.7](#).
3. Back the vehicle close to the trailer, centering the kingpin on the fifth wheel.
4. Chock the trailer wheels.
5. Connect the air lines and electrical cable.
6. Ensure that the red trailer air supply valve (trailer brake) is pulled out, and that the trailer parking





**Fig. 17.7, Jost Release Handle Unlocked**

brakes are set. See [Chapter 5](#) in this manual for operation of the dash-mounted brake controls.

## NOTICE

**Attempting to couple at the wrong height may cause improper coupling, which could result in damage to the fifth wheel or kingpin.**

- Adjust the trailer height (if required).

**For a standard fifth wheel plate**, the trailer should contact the fifth wheel approximately 4 to 8 inches (10 to 20 cm) behind the pivot. See [Fig. 17.4](#).

**For a low-lube fifth wheel plate**, the fifth wheel must slide freely under the trailer, and the trailer should contact the fifth wheel at the pivot. See [Fig. 17.5](#).

- Back the tractor under the trailer.

On a standard fifth wheel, the fifth wheel must lift the trailer.

On a low-lube fifth wheel, do not lift the trailer as this may damage the fifth wheel plate.

- After sliding under the trailer, STOP to prevent from hitting the kingpin too hard, then resume backing slowly until the fifth wheel locks.

## WARNING

**A visual inspection is required by law. Some improper couplings can pass a pull test. Sound is not reliable. Get out of the cab and look. Incorrect coupling could cause the trailer to discon-**

**nect, possibly resulting in serious personal injury or death.**

- Apply the tractor parking brake, then perform a physical check for positive kingpin lockup, and that there is no gap between the trailer and the fifth wheel. See [Fig. 17.6](#).
- Ensure that the release handle is in the locked position adjacent to the casting. See [Fig. 17.8](#).
- Release the tractor parking brakes and test for kingpin lockup by slowly moving the tractor forward, pulling on the trailer against the chocks.

## Fifth Wheel Uncoupling

### Manual Uncoupling

- Apply the tractor and trailer parking brakes.
- Chock the trailer rear wheels.
- Lower the trailer landing gear until the weight is removed from the fifth wheel.
- Disconnect the tractor-to-trailer air system lines and electrical cable. Plug the air lines to prevent dirt or foreign material from entering the lines.
- Verify that both the yellow parking-brake and red trailer-air-supply knobs are out, the tractor and trailer parking brakes are set, and that the trailer is prepared for uncoupling.
- Release the kingpin locking mechanism following the instructions for each manufacturer below.
  - Fontaine:** Lift the safety latch and pull the lock control handle to the unlocked position. See [Fig. 17.2](#).
  - Holland:** In the locked position the safety indicator swings freely over the operating rod. See [Fig. 17.9](#), View A.

To unlock the mechanism, manually rotate the safety indicator toward the rear of the fifth wheel. See [Fig. 17.9](#), View B.

Pull the operating rod out. When the upper operating rod shoulder is outside the slot, raise the handle and place the shoulder of the upper rod against the plate casting, above the slot. See [Fig. 17.9](#), View C.

# Fifth Wheels

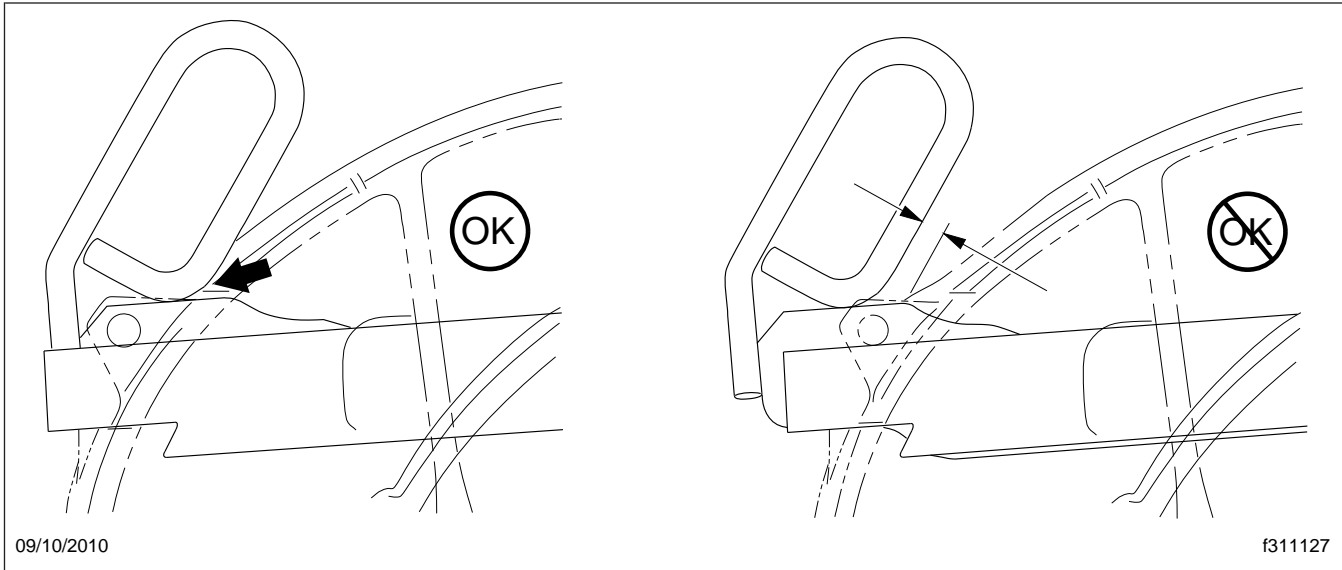


Fig. 17.8, Jost Release Handle Locked

The fifth wheel is now in the lockset position and is ready for uncoupling. As the tractor pulls away from the trailer the kingpin forces the jaw to rotate, contacting the lock. Continued rotation of the jaw forces the lock to move outward, and drops the upper rod back into the slot. See Fig. 17.9 View D. The wheel is now ready for coupling.

- 6.3 **Jost:** Pull the retractable handle out, then secure it in the open position with the catch. See Fig. 17.7.
7. Release the tractor parking brake then drive out slowly, allowing the trailer to slide down the fifth wheel and pick-up ramps.

## Air-Actuated Uncoupling

An air-actuated kingpin release valve is optional with all fifth wheels. See Fig. 17.10.

**NOTE:** In the event of an air system failure, air-actuated kingpins can be manually released following the instructions for manual unlocking.

### **WARNING**

Once the kingpin release valve has been pulled the kingpin lock is released. The vehicle **MUST NOT** be driven with the trailer until the trailer has

been uncoupled and coupled again. Failure to do so may result in separation of the trailer from the tractor, possibly causing serious personal injury or death.

## Preparing the Trailer for Uncoupling

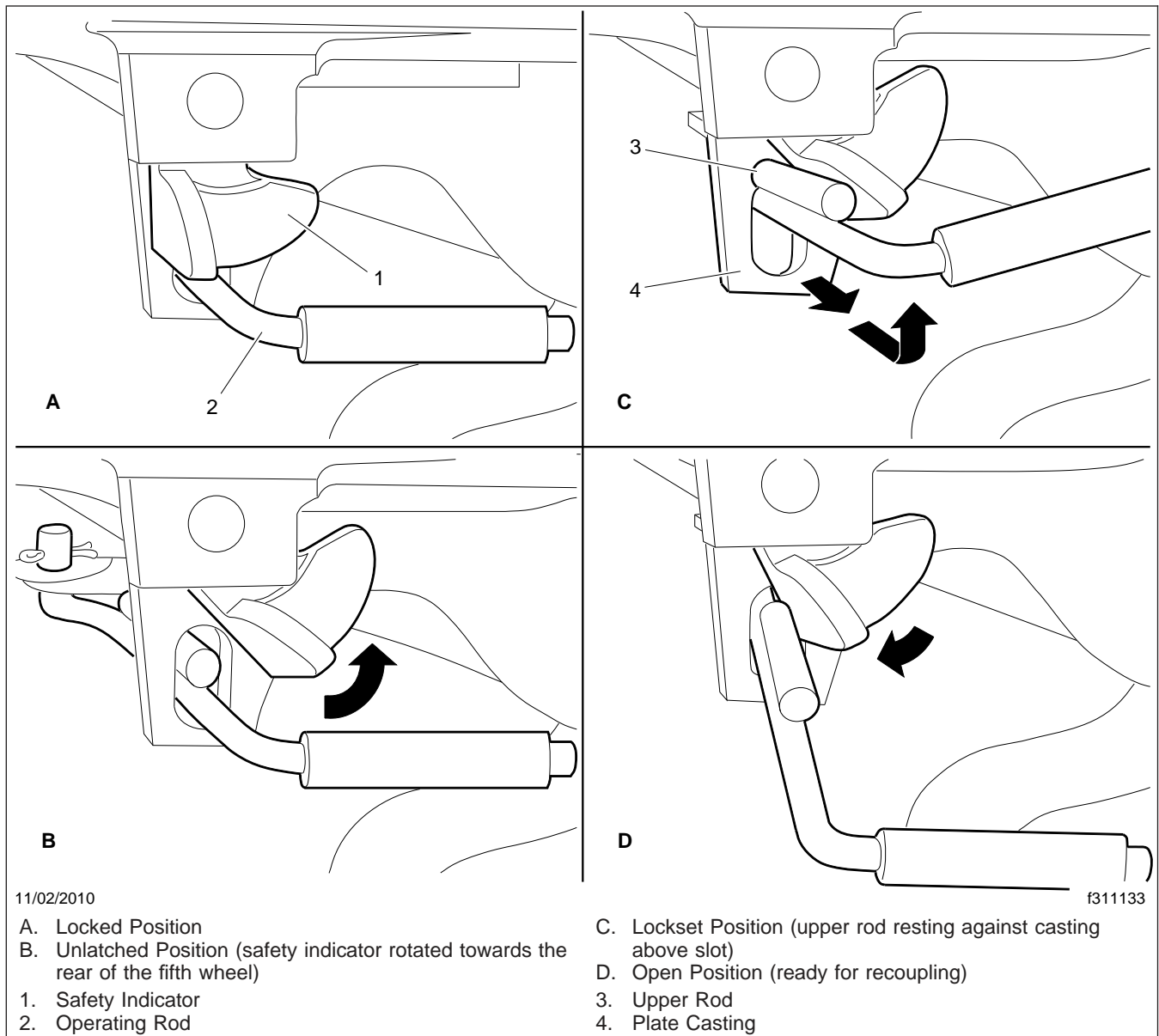
Before using the air valve to unlock a fifth wheel kingpin, prepare the trailer as follows.

1. Apply the tractor and trailer parking brakes.
2. Chock the trailer rear wheels.
3. Lower the trailer landing gear until the weight is removed from the fifth wheel.
4. Disconnect the tractor-to-trailer air lines and electrical cable. Plug the air lines to prevent dirt or foreign material from entering the lines.

## Fontaine and Holland Fifth Wheels Air-Activated Kingpin Unlock

1. Verify that both the yellow parking-brake and red trailer-air supply knobs are out, the tractor and trailer parking brakes are set, and that the trailer is prepared for uncoupling.

**NOTE:** On Fontaine and Holland fifth wheels, if the tractor parking brake is not set, the air-actuated kingpin-release valve will not activate.



11/02/2010

- A. Locked Position
- B. Unlatched Position (safety indicator rotated towards the rear of the fifth wheel)
- 1. Safety Indicator
- 2. Operating Rod

- C. Lockset Position (upper rod resting against casting above slot)
- D. Open Position (ready for recoupling)
- 3. Upper Rod
- 4. Plate Casting

**Fig. 17.9, Holland Kingpin Locking Mechanism**

2. Pull and hold the kingpin release valve (**Fig. 17.10**) until the kingpin lock mechanism opens and locks in place.
3. Release the pull valve.
4. Release the tractor parking brake.
5. Drive out from under the trailer.

### Jost Fifth Wheels Air-Activated Kingpin Unlock

1. Verify that both the yellow parking-brake and red trailer-air-supply knobs are out, the tractor and trailer parking brakes are set, and that the trailer is prepared for uncoupling.

# Fifth Wheels

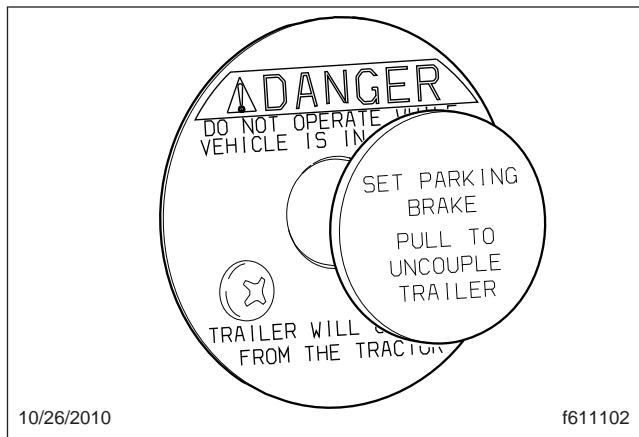


Fig. 17.10, Air-Actuated Kingpin Release Valve

NOTE: With Jost fifth wheels, if the trailer parking brake is not set the air-actuated valve will not activate.

2. Release the tractor parking brake.
3. Pull and hold the kingpin release valve, then drive forward slowly.
4. After the trailer has slid down the fifth wheel and pick-up ramps, release the pull valve.

## Fifth Wheel Slide

### WARNING

Adjust the fifth wheel slide correctly, and do not overload any tractor axle by incorrectly loading the trailer. Incorrect slide adjustment or improper axle loading could cause erratic steering and loss of vehicle control, possibly resulting in serious personal injury or death.

On sliding fifth wheel assemblies, the fifth-wheel plate is attached to rails that allow forward and rearward movement of the fifth wheel to optimally distribute the load across the axles. Slots are evenly spaced along the slide rails, and retractable wedges are positioned through the slots to hold the fifth wheel in the desired position.

The amount of load distribution on the front steering axle and rear drive axle(s) will have a direct effect on the steering control of the vehicle. Determine the front and rear axle weights by weighing the vehicle on scales designed for this purpose.

The maximum axle weight ratings are shown on the Federal Motor Vehicle Safety Standard (FMVSS) label or Canadian Motor Vehicle Safety Standard (CMVSS) label attached to the left rear door post of the tractor. The desired load on the axle is no less than 80 percent of the maximum axle weight rating, but in no instances should the axle load exceed the maximum axle weight rating given on the FMVSS or CMVSS label.

## Manual Slide Operation

The manual slide feature is operated from the fifth wheel plate with a manual release handle using the following procedure. See Fig. 17.11.

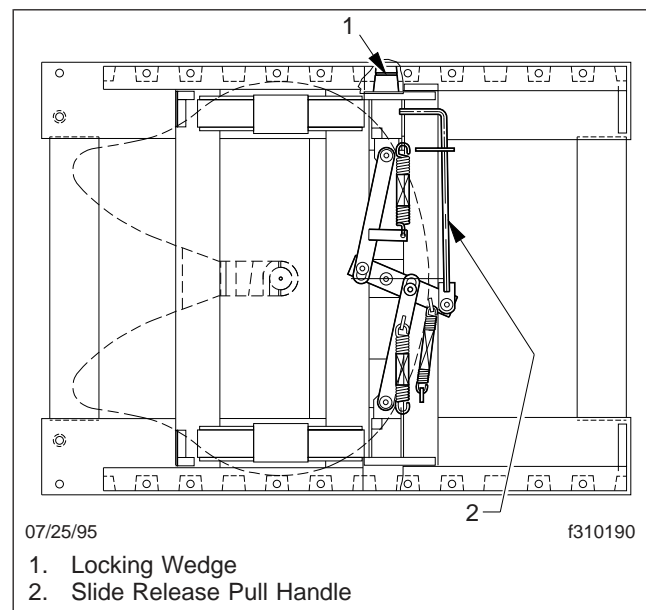
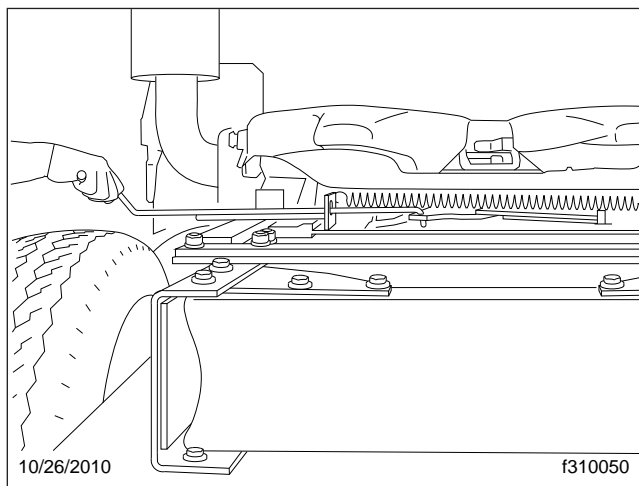


Fig. 17.11, Manual Release Sliding Fifth Wheel (Fontaine shown)

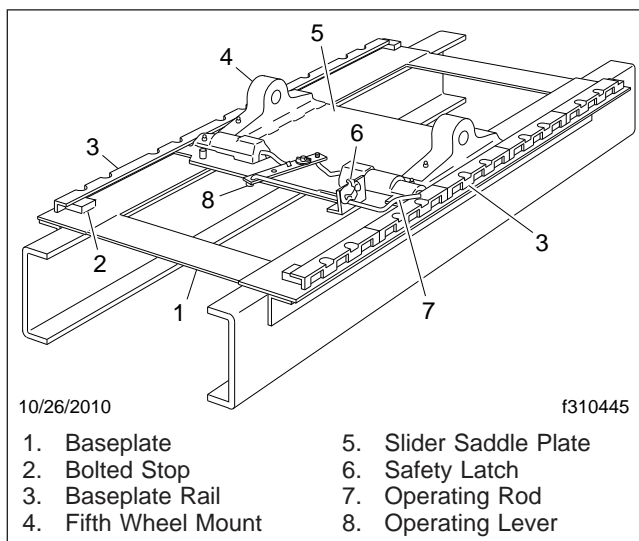
1. Stop the tractor and trailer in a straight line on level ground. Pull the red trailer air supply knob to apply the trailer parking brakes.
2. Apply the tractor parking brake, then release the sliding mechanism using the appropriate method for the fifth wheel manufacturer.
  - 2.1 **Fontaine:** Lift the slide release pull handle to disengage it from the guide plate. Then, pull out the handle until it is in the unlocked position and can be positioned against the guide plate to hold it out. The

handle will stay in the unlocked position until it is manually disengaged from the guide plate. See [Fig. 17.12](#).



**Fig. 17.12, Releasing the Sliding Fifth Wheel, (Fontaine)**

- 2.2 **Holland:** Pull the operating rod out. Make sure both side plungers have released. See [Fig. 17.13](#).



**Fig. 17.13, Sliding Fifth Wheel Manual Release, (Holland Simplex)**

3. Lower the trailer landing gear just enough to remove the weight from the tractor.
4. Chock the front and rear of the trailer tires to prevent the trailer from moving.

5. Release the tractor parking brakes, then slowly move the tractor forward or backward until the fifth wheel is in the desired location.

## NOTICE

**When moving the fifth wheel to the desired position, be sure the trailer landing gear will not at any time come in contact with the tractor frame or other components. Make sure that the front of the trailer will not come in contact with the rear of the cab or with other components if they extend beyond the rear of the cab.**

## ⚠ WARNING

**Check that the locking wedges have seated in the slots. Failure to achieve complete lockup may allow disengagement of the tractor from the trailer, possibly resulting in serious personal injury or death.**

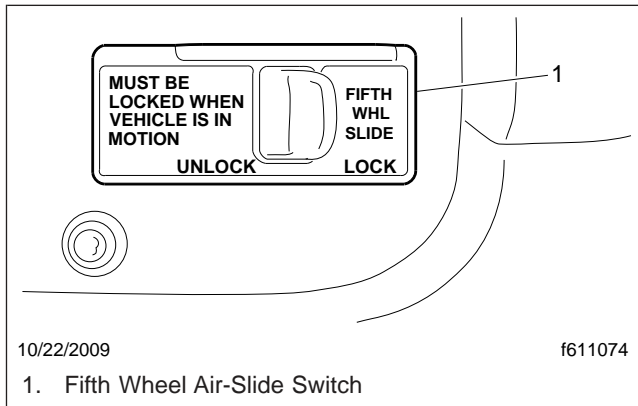
6. Apply the tractor parking brakes, then lock the sliding member in position using one of the following methods:
  - 6.1 **Fontaine:** Disengage the slide release pull handle from the guide plate. The slide release pull handle is spring-loaded in the locked position and will seek the locked position when disengaged from the guide plate. After the slide release pull handle returns to the fully locked position, visually and physically check the locking wedges to make sure they are fully inserted into the slots in the slide rails. Make sure the handle is locked in position against the guide plate.
  - 6.2 **Holland:** Raise the operating rod so that it is free to move inward. Make sure that the lock pins have seated in the base plate rail holes and the operating rod moves into the locked position.

**NOTE:** The fifth wheel may need to be moved slightly to enable the locking wedges to enter the fully locked position.

# Fifth Wheels

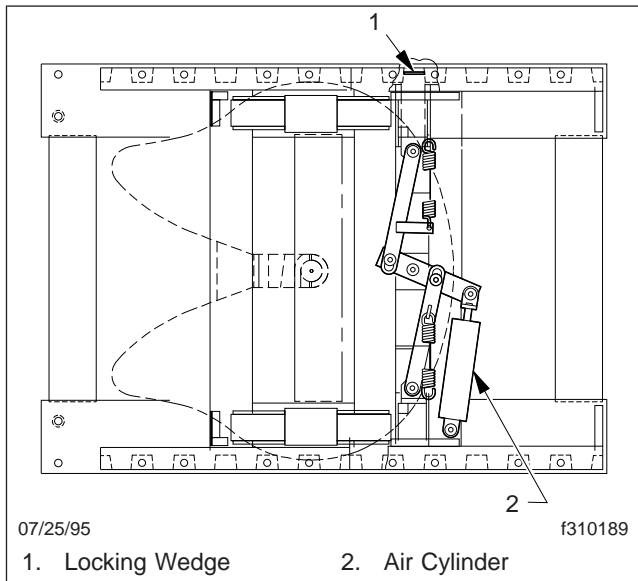
## Air Slide Operation

The slide feature may be operated with an air switch mounted in the dash, that operates an air cylinder that locks and unlocks the slide. See [Fig. 17.14](#).

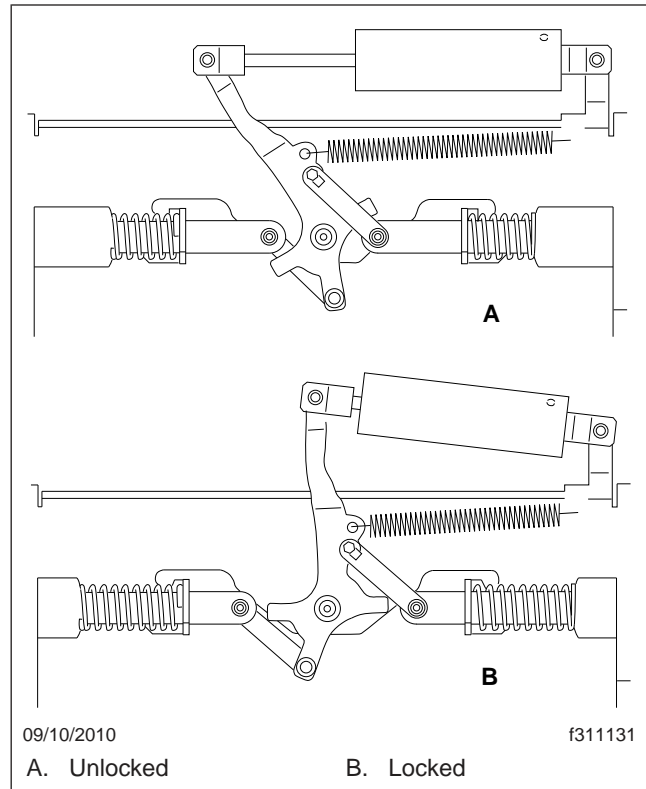


**Fig. 17.14, Air-Slide Switch**

1. Set the air-slide switch ([Fig. 17.14](#)) to UNLOCK. Ensure the locking plungers have released. See [Fig. 17.15](#).  
For Jost fifth wheels, the mechanism activates as shown in [Fig. 17.16](#).



**Fig. 17.15, Air-Operated Sliding Fifth Wheel (Fontaine shown)**



**Fig. 17.16, Jost Sliding Fifth Wheel**

2. Lower the trailer landing gear just enough to remove the weight from the tractor.
3. Pull the red trailer-air-supply knob to set the trailer-parking brakes.
4. Slowly move the tractor forward or backward until the fifth wheel is in the desired location.

### NOTICE

Ensure the trailer landing gear does not come in contact with the tractor frame or other components, and that the front of the trailer will not come in contact with the rear of the cab or other components if they extend beyond the rear of the cab.

5. Apply the tractor parking brakes.



Check that the locking wedges have seated in the slots. Failure to achieve complete lockup may

**allow disengagement of the tractor from the trailer, possibly resulting in serious personal injury or death.**

6. Set the air-slide switch to LOCK. Visually inspect the locking wedges or plungers to make sure that they are fully inserted in the slide rail slots. Verify that the plungers have engaged by tugging the tractor forward while the trailer brakes are locked and the wheels are chocked.

NOTE: The fifth wheel may need to be moved slightly to enable the locking wedges to fully lock.

# 18

## Trailer Couplings

---

|                                 |      |
|---------------------------------|------|
| Air Suspension Dump Valve ..... | 18.1 |
| Holland Trailer Coupling .....  | 18.1 |
| Premier Trailer Couplings ..... | 18.2 |



# Trailer Couplings

## Air Suspension Dump Valve

The air-suspension height switch may be used to aid in connecting or disconnecting from a trailer. When the switch is set to LOWER, the air-suspension dump valve deflates the air springs to lower the rear of the vehicle. In the normal position, the automatic ride-control valves operate for normal driving.

### NOTICE

**Do not operate the vehicle over uneven ground such as ramps, speed bumps, curbs, etc. with the air springs deflated. Doing this may lead to air bag separation from the piston, preventing the suspension air springs from reinflating.**

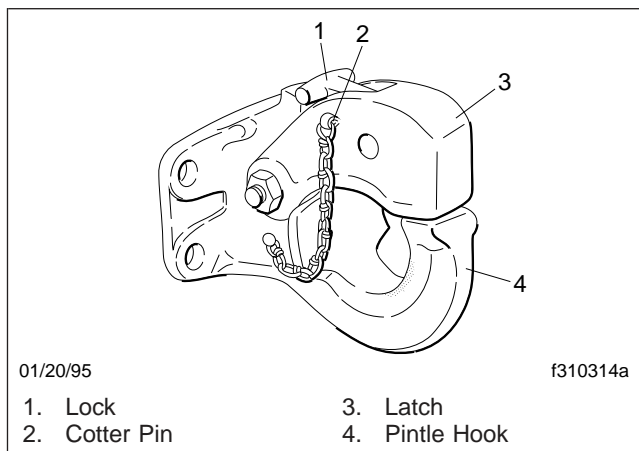
### NOTICE

**Never exhaust air from the suspension while driving. When the air is exhausted, the suspension will not absorb road shocks, and components may be damaged.**

## Holland Trailer Coupling

### General Information

The Holland PH-T-60-AL trailer coupling is designed for use with trailers having a maximum gross weight of 10,000 lb. See [Fig. 18.1](#). It is a rigid-type pintle hook, used only on tractor applications, and is fastened to the rear closing crossmember of the vehicle. It is a non-air-adjusted coupling.



**Fig. 18.1, Holland PH-T-60-AL Trailer Coupling**

## Operation

### Trailer Hookup

1. Chock the front and rear tires of the trailer.
2. Remove the cotter pin, then lift the lock and raise the latch.
3. Back up the vehicle, until the drawbar eye is over the pintle hook.
4. Lower the trailer, until the drawbar eye rests on the pintle hook.
5. Close the latch, then insert the cotter pin.

### NOTICE

**Always make sure the connect-hanger/support keeps the trailer air hoses and electrical cables positioned so that they do not rub on anything. Rubbing may wear through hoses or cables, resulting in air leaks, or exposed or broken wires, potentially affecting trailer brake or electrical systems.**

6. Hook up the trailer electrical and air lines.
7. Remove the chocks from the trailer's tires.

### Trailer Release

1. Apply the tractor and trailer parking brakes.

### **WARNING**

**Do not use the trailer air supply for parking trailers not equipped with spring parking brakes. This applies the trailer service brakes only. As air bleeds from the trailer brake system, brake application is lost. This could allow the unattended vehicle to roll away, possibly resulting in serious personal injury or death.**

2. Chock the front and rear tires of the trailer.
3. Disconnect the trailer air and electrical lines. Plug the air lines to keep out dirt.
4. Take the weight of the trailer drawbar off the pintle hook.
5. Open the latch, by first removing the cotter pin, then lift up the lock and raise the latch.
6. Slowly drive the vehicle away from the trailer.

## Premier Trailer Couplings

### General Information

**IMPORTANT:** Before operating the Premier coupling, refer to the Premier web site at [www.premier-mfg.com](http://www.premier-mfg.com) for complete safety, operation, and maintenance instructions.

Trailer couplings, used only on trucks, are attached to the rear closing crossmember.

The Premier 260 and 460 trailer couplings have a rigid pintle hook, and are air-adjusted. An air chamber, mounted forward of the coupling, operates a pushrod, which pushes against a shoe inside the coupling. The shoe maintains constant pressure on the eye of the trailer drawbar when it's over the pintle hook. See **Fig. 18.2**. This takes up any slack in the trailer connection, providing smoother towing and less wear on the pintle hook. The air pressure is activated when the trailer brakes are released.

The Premier 690 trailer coupling has a moveable pintle hook, and is non-air adjusted. It is used for heavy-duty applications. See **Fig. 18.3**.

### Operation

#### **WARNING**

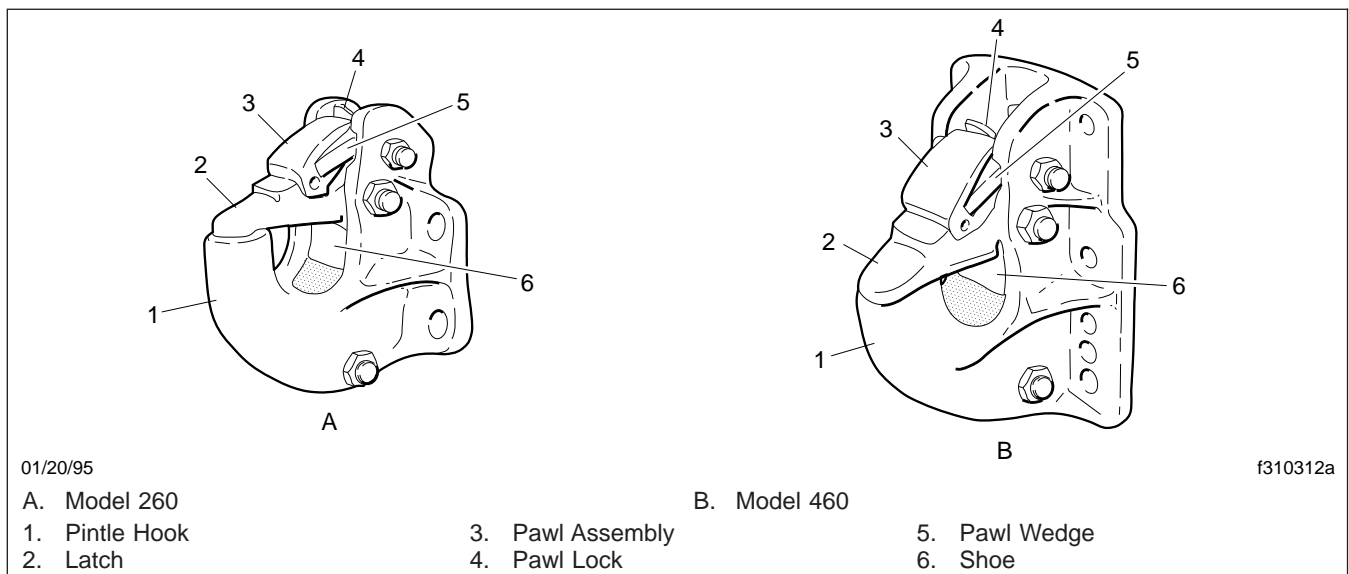
**If at any time the 690 coupling is bound up (jackknifed), the 294 bolt MUST be replaced immediately! Do not use the coupling until the bolt has been replaced. In addition, carefully inspect the 690 coupling, drawbar, drawbar eye, front end assembly, and tail board for damage. Failure to do so may result in trailer separation from the truck while in use, resulting in serious personal injury or property damage.**

### Trailer Hookup

1. Chock the front and rear tires of the trailer.
2. Open the coupling.

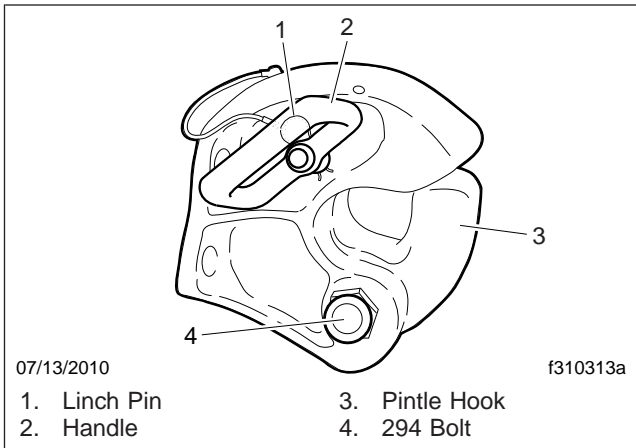
*Models 260 and 460:* Pull up on the pawl lock; then, while squeezing the pawl wedges together, lift up the pawl assembly. Lift up the latch, and push it up against the pawl assembly, locking the latch in place. See **Fig. 18.2**.

*Model 690:* Remove the linch pin from the handle, then push in on the handle and turn it toward you. Open the pintle hook by pulling it down and toward you. Release the handle, locking the pintle hook open. See **Fig. 18.3**.



**Fig. 18.2, Premier 260 and 460 Trailer Couplings**

# Trailer Couplings



**Fig. 18.3, Premier 690 Trailer Coupling**

3. *Models 260 and 460:* Back up the vehicle until the drawbar eye is over the pintle hook, then lower the trailer.  
*Model 690:* Back up the vehicle until the drawbar eye enters the open jaw, contacts the back of the pintle hook, and closes the coupling.
4. Close the coupling.  
*Models 260 and 460:* Push in on the pawl wedges and lift the pawl assembly. The latch will drop into the closed position. Lock the latch by lowering the pawl assembly.  
*Model 690:* The pintle hook will automatically close and lock from the pressure of the drawbar eye against it. Install the linch pin.

## NOTICE

**Always make sure the connect-hanger/support keeps the trailer air hoses and electrical cables positioned so that they do not rub on anything. Rubbing may wear through hoses or cables, resulting in air leaks, or exposed or broken wires, potentially affecting trailer brake or electrical systems.**

5. Hook up the trailer's electrical and air lines.
6. Remove the chocks from the trailer's tires.

## Trailer Release

1. Apply the truck and trailer parking brakes.

## WARNING

**Do not use the trailer air supply for parking trailers not equipped with spring parking brakes. This applies the trailer service brakes only. As air bleeds from the trailer brake system, brake application is lost. This could allow the unattended vehicle to roll away, possibly resulting in serious personal injury or death.**

2. Chock the front and rear tires of the trailer.
3. Disconnect the trailer air and electrical lines. Plug the air lines to keep out dirt.
4. Take the weight of the trailer drawbar eye off the pintle hook.
5. Open the coupling.  
*Models 260 and 460:* Pull up on the pawl lock; then, while squeezing the pawl wedges together, lift up the pawl assembly. Lift up the latch, and push it up against the pawl, locking the latch in place.  
*Model 690:* Remove the linch pin from the handle, then push in on the handle and turn it toward you. Open the pintle hook by pulling it down and toward you. Release the handle, locking the pintle hook open.
6. Slowly drive the vehicle away from the trailer.

# 19

## Pre- and Post-Trip Checklists

---

|   |      |
|---|------|
| Periodic Inspections and Maintenance, General Information ..... | 19.1 |
| Checklists .....  | 19.1 |
| Fluids Added .....  | 19.2 |

# Pre- and Post-Trip Checklists

## Periodic Inspections and Maintenance, General Information

Regulations in Canada and the U.S. clearly indicate that it is the driver's responsibility to perform an inspection, and ensure the complete road-worthiness of a vehicle, before placing it into service. Commercial vehicles may be subject to inspection by authorized inspectors, and an unsafe vehicle can be taken "out of service" until the driver or owner repairs it.

Use the following checklists to ensure that vehicle components are in good working condition before each trip. Careful inspections eliminate stops later to fix overlooked or forgotten items.

The checklists in this chapter can be copied and kept as a record that the procedures have been completed. For details on how to inspect each item on the checklists, see the corresponding procedure (step number) in [Chapter 20](#).

## Checklists

NOTE: Checklists in this chapter correspond with the procedures and steps in [Chapter 20](#), *Pre- and Post-Trip Inspections and Maintenance*. Your vehicle may not be equipped with all components listed below.

### Daily Pretrip Inspection Checklists

See the following tables for a list of procedures that should be performed daily, before the first trip. Place a check mark in the complete (**Comp.**) column to indicate a procedure has been performed.

| Inspector | Date |
|-----------|------|
|           |      |

| Suspension and Slack Adjusters |                       | Comp. |
|--------------------------------|-----------------------|-------|
| 1                              | Suspension components |       |
| 2                              | Slack adjusters       |       |

| Wheels and Tires |                           | Comp. |
|------------------|---------------------------|-------|
| 1                | Wheel covers              |       |
| 2                | Tire condition            |       |
| 3                | Tire inflation            |       |
| 4                | Rims and wheel components |       |

| Wheels and Tires |  | Comp. |
|------------------|--|-------|
| 5                | Wheel bearing oil seals and lubrication levels |       |
| 6                | Mud Flaps                                      |       |

| Saddle Tank Areas |   | Comp. |
|-------------------|---|-------|
| 1                 | Drain air reservoirs (without automatic drain valves) |       |
| 2                 | Fuel tank(s) secure                                   |       |
| 3                 | Frame rails and crossmembers                          |       |
| 4                 | Visible exhaust components                            |       |

| Engine Compartment |                                | Comp. |
|--------------------|--------------------------------|-------|
| 1                  | Leakage under engine           |       |
| 2                  | Air intake system              |       |
| 3                  | Engine oil level               |       |
| 4                  | Power steering reservoir level |       |
| 5                  | Engine coolant level           |       |
| 6                  | Visible engine wiring          |       |
| 7                  | Frame rails                    |       |

| Cab |   | Comp. |
|-----|---|-------|
| 1   | Reset dash-mounted air intake restriction indicator |       |
| 2   | Air-pressure warning systems                        |       |
| 3   | Air governor cut-in and cut-out pressures           |       |
| 4   | Air pressure build-up time                          |       |
| 5   | Air system leakage                                  |       |
| 6   | Air pressure reserve                                |       |
| 7   | Mirrors, windows, windshield                        |       |
| 8   | Horn, windshield wipers, windshield washers         |       |
| 9   | Heater and defroster                                |       |
| 10  | Interior lights                                     |       |
| 11  | Exterior lights                                     |       |
| 12  | Seat belts and tether belts                         |       |
| 13  | Fuel level  |       |
| 14  | Mirror adjustment                                   |       |
| 15  | Service brakes                                      |       |
| 16  | Backup alarm  |       |

# Pre- and Post-Trip Checklists

## Weekly Post-trip Inspection Checklist

See the following table for procedures that should be performed weekly, post-trip. Place a check mark in the complete (**Comp.**) column to indicate a procedure has been performed.

| Inspector |  | Date |
|-----------|--|------|
|           |  |      |

| Engine Compartment |                                    | Comp. |
|--------------------|------------------------------------|-------|
| 1                  | Windshield washer reservoir level  |       |
| 2                  | Air intake restriction indicator   |       |
| 3                  | Water evacuation components        |       |
| 4                  | Automatic transmission fluid level |       |
| 5                  | Water in fuel/water separator      |       |
| 6                  | Steering components                |       |
| 7                  | Serpentine drive belts             |       |

## Fluids Added

Use the following table to note any fluids that were added during the inspection and maintenance procedures.

| Fluids Added During Inspection             |              |
|--|--------------|
| Fluid                                      | Amount Added |
| Wheel Bearing Lubricant                    |              |
| Engine Oil                                 |              |
| Power Steering Fluid                       |              |
| Engine Coolant                             |              |
| Windshield Washer Fluid                    |              |
| Automatic Transmission Fluid               |              |
| Hydraulic Clutch Fluid (DOT 4 brake fluid) |              |

## Monthly Post-trip Inspection Checklists

See the following tables for procedures that should be performed monthly, post-trip. Place a check mark in the complete (**Comp.**) column to indicate a procedure has been performed.

| Inspector |  | Date |
|-----------|--|------|
|           |  |      |

| Brake Components |                               | Comp. |
|------------------|-------------------------------|-------|
| 1                | Brake system components       |       |
| 2                | Brake chambers                |       |
| 3                | Air brake lines               |       |
| 4                | Flex air hoses                |       |
| 5                | Brake linings and brake drums |       |
| 6                | Brake lining thickness        |       |

| Saddle Tank Areas |  | Comp. |
|-------------------|--|-------|
| 1                 | Drain air reservoirs (with automatic drain valves) |       |
| 2                 | Batteries (location may vary)                      |       |
| 3                 | Aerodynamic components                             |       |

| Engine Compartment |                            | Comp. |
|--------------------|----------------------------|-------|
| 1                  | Hood and bumper            |       |
| 2                  | Hydraulic clutch reservoir |       |
| 3                  | Radiator and heater hoses  |       |
| 4                  | Steering wheel play        |       |

# 20

## Pre- and Post-Trip Inspections and Maintenance

---

|  |       |
|--|-------|
| Daily Pretrip Inspection and Maintenance .....     | 20.1  |
| Weekly Post-Trip Inspection and Maintenance .....  | 20.8  |
| Monthly Post-Trip Inspection and Maintenance ..... | 20.10 |

# Pre- and Post-Trip Inspections and Maintenance

## Daily Pretrip Inspection and Maintenance

Complete the following inspection and maintenance procedures to ensure that vehicle components are in good working condition before each trip. A driver who is familiar with the vehicle and drives it regularly can perform the daily inspections, then add the weekly and monthly post-trip inspections as scheduled.

If the driver does not operate the vehicle on a consistent basis, all daily, weekly, and monthly inspection and maintenance procedures should be performed before the trip.

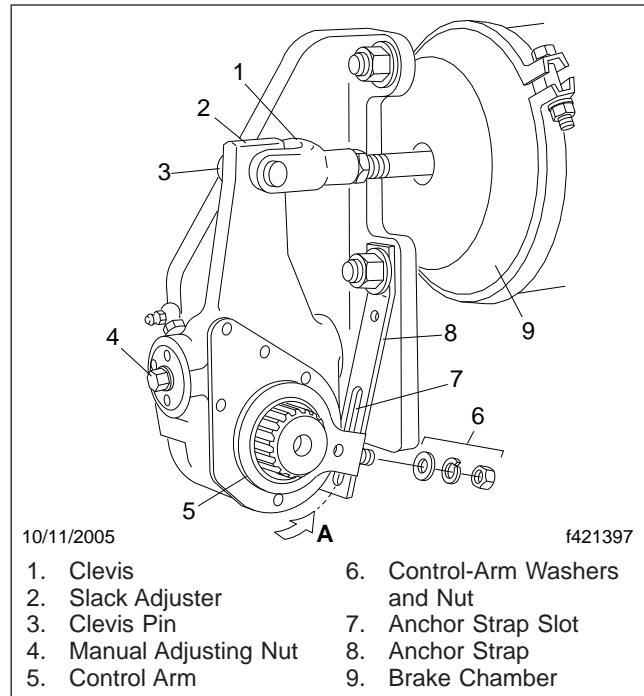
**IMPORTANT:** The pre- and post-trip checklists, inspections, and maintenance procedures detailed in this chapter are **not all-inclusive**. Refer to other component and body manufacturers' instructions for specific inspection and maintenance instructions, as well as local, state, and federal guidelines.

**NOTE:** If any system or component does not pass this inspection, it must be corrected before operating the vehicle. Whenever equipment requires adjustment, replacement, and/or repair, see the *122SD and Coronado Workshop Manual* for procedures and specifications.

## Suspension and Slack Adjuster Inspection

Walk around the vehicle and visually inspect suspension and slack adjuster components.

1. Inspect the following suspension components for signs of structural damage, cracks, or wear.
  - springs
  - spring hangers
  - shocks
  - suspension arms
  - suspension brackets
  - axle seats
  - bushings
2. Inspect slack adjusters for signs of damage. See [Fig. 20.1](#) or [Fig. 20.2](#).



**Fig. 20.1, Haldex Automatic Slack Adjuster**

- Inspect slack adjuster boots, if equipped, for cuts or tears.
- Inspect anchor straps, if equipped, for damage.
- Look for worn clevis pins on brake chamber pushrods.
- Look for missing or damaged cotter pins on the clevis pins.
- Ensure chamber piston rods are in line with the slack adjusters.

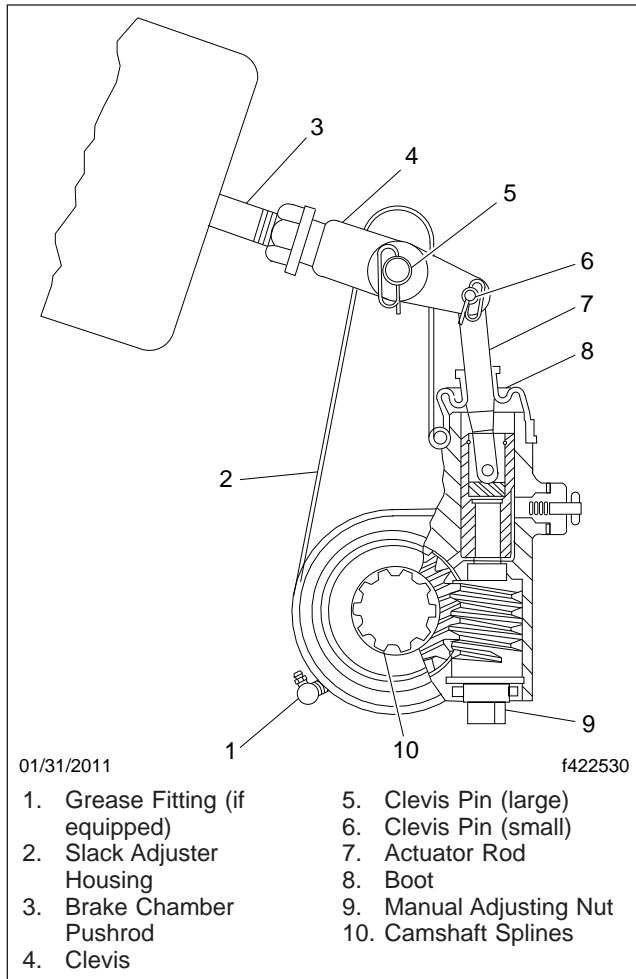
## Wheel and Tire Inspection

Walk around the vehicle and visually inspect each wheel and tire assembly.

**IMPORTANT:** Wheel covers decrease drag force as a vehicle moves, thereby improving fuel efficiency. If replacement of a wheel cover is necessary, the replacement cover must meet or exceed the drag reduction performance of the originally installed cover in order to maintain compliance with greenhouse gas and full efficiency regulations (GHG14).



# Pre- and Post-Trip Inspections and Maintenance



**Fig. 20.2, Meritor Automatic Slack Adjuster**

1. If the vehicle was originally equipped with wheel covers, ensure all wheel covers are present. Inspect wheel covers for damage or wear. Remove wheel covers from rear drive wheels, if equipped, prior to inspecting the tires and wheel components.

**NOTE:** During wheel cover installation, ensure the V-notch in the liner inner retaining ring is centered on the valve stem. The inner and outer retaining rings should be uniformly aligned to each other and to the wheel rim. The outer retaining ring of the liner is equipped with two canvas flaps. When installing the face cover, make sure the cover retaining ring is inserted between the two canvas flaps on the liner outer

retaining ring so that the Velcro strips line up between the face cover and the liner. Make certain the detachable view cover is centered on the face cover, and the Velcro strips are pressed firmly in place.

2. Inspect each tire for the following:

- valve stem caps on every tire, screwed on finger-tight
- bulges, cracks, cuts, and penetrations
- oil contamination (petroleum derivatives will soften the rubber and destroy the tire)
- tread depth—if tread is less than 4/32 inch (3 mm) on any front tire, or less than 2/32 inch (1.5 mm) on any rear tire, replace the tire
- debris lodged between dual tire sets

**IMPORTANT:** Low-rolling resistance (LRR) tires minimize wasted energy as a tire rolls, thereby decreasing rolling effort and improving fuel efficiency. If tire replacement is necessary, replacement tires must meet or exceed the rolling resistance of the originally installed tires in order to maintain compliance with greenhouse gas and full efficiency regulations (GHG14).

Contact your tire manufacturer/supplier to determine the rolling resistance of the originally installed tires. Visit [www.epa.gov/smartway](http://www.epa.gov/smartway) for additional information and resources.

3. Check tire inflation.

For inflation pressures and maximum loads, see the tire manufacturer's guidelines. Inflate the tires to the applicable pressures if needed.

If a tire has been run flat or under-inflated, check the wheel and tire for damage before adding air.

Keep compressed air reservoirs and lines dry during tire inflation. Use well-maintained inline moisture traps and service them regularly.

## **WARNING**

**Do not operate the vehicle with underinflated or overinflated tires. Incorrect inflation can stress the tires and make the tires and rims more susceptible to damage, possibly leading to rim or**

# Pre- and Post-Trip Inspections and Maintenance

tire failure and loss of vehicle control, resulting in serious personal injury or death.

## NOTICE

A weekly pressure loss of 4 psi (28 kPa) or more in a tire may indicate damage. The tire should be inspected and, if necessary, repaired or replaced by a qualified tire service facility.

IMPORTANT: The load and cold inflation pressure must not exceed the rim or wheel manufacturer's recommendations, even though the tire may be approved for a higher load inflation. Consult the rim or wheel manufacturer for the correct tire inflation pressure for the vehicle load.

4. Examine each rim and wheel component.
  - 4.1 Remove all dirt and debris from the assembly. Rust streaks or metal build-up around stud holes, or out-of-round or worn stud holes, may be caused by loose wheel nuts.

## WARNING

Have any worn or damaged wheel components replaced by a qualified person using the wheel manufacturer's instructions and the wheel industry's standard safety precautions and equipment. Otherwise a vehicle or workshop accident could occur, possibly resulting in serious personal injury or death.

- 4.2 Inspect for broken, cracked, badly worn, bent, rusty, or sprung rings and rims.

## NOTICE

Use the recommended torque values and follow the proper tightening sequence. Insufficient wheel nut torque can cause wheel shimmy, resulting in wheel damage, stud breakage, and extreme tire tread wear. Excessive wheel nut torque can break studs, damage threads, and crack discs in the stud hole area.

- 4.3 Make sure all wheel nuts are tightened. If tightening is necessary, use the tightening pattern in [Fig. 20.3](#) to initially tighten the

flange nuts to 50 to 100 lbf-ft (68 to 136 N·m). Then tighten the flange nuts to 450 to 500 lbf-ft (610 to 678 N·m).

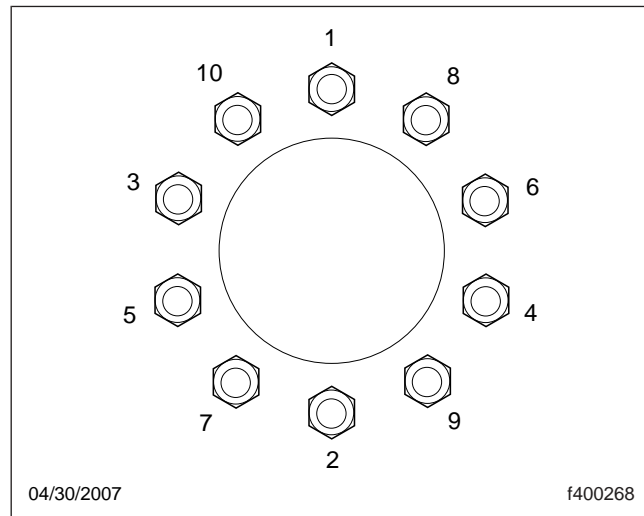


Fig. 20.3, Tightening Pattern, 10-Hole Wheels

5. Inspect the outboard side of all wheel hubs and the hub oil seal area on the inboard side of each wheel for signs of oil leakage. If any oil is found on wheel and tire or brake components, remove the vehicle from service until the leak has been fixed.

If needed, fill the hubs to the level indicated on the hub cap. See **Group 35** of the *122SD and Coronado 132 Maintenance Manual* for recommended lubricants.

6. Check that mud flaps are undamaged and hang 10 inches (25.4 cm) or less from the ground.

## Saddle Tank Areas Inspection

## WARNING

When draining the air reservoir, do not look into the air jets or direct them toward anyone. Dirt or sludge particles may be in the airstream and could cause injury.

## NOTICE

If the water drained from the air reservoirs is cloudy or oily, it may indicate a problem with the compressor. If oil is allowed to contaminate the

# Pre- and Post-Trip Inspections and Maintenance

air dryer, it will not remove the water from the air brake system, which could adversely affect braking.

1. Drain the brake system air reservoirs (reservoirs without automatic drain valves only).

## WARNING

Never operate the engine with the fuel tank shut-off valves partially closed. This could damage the fuel pump, causing sudden loss of engine power, possibly resulting in serious personal injury due to reduced vehicle control.

2. Ensure fuel tanks are secured to their mounting brackets and that the mounting brackets are secured to the frame.

If equipped with fuel tank shutoff valves, be sure the valves are fully open.

3. Inspect visible frame rails for missing bolts, shiny areas, or rust streaks. Check all visible cross-members for damage or signs of looseness.
4. Inspect visible components of the exhaust system to ensure connections are tight.

Inspect upstream of the aftertreatment device (ATD), if equipped, for cracking or signs of leaks, such as soot trails. Inspect downstream of the ATD for signs of exhaust leaks, such as blistering or warping of nearby components.

## Engine Compartment Inspection

1. Check the ground underneath the engine for fuel, oil, or coolant leaks.
2. Inspect the air intake system for leaks or damage.

## NOTICE

Failure to maintain a sealed air intake system could allow the entry of dirt and contaminants into the engine. This could adversely affect engine performance and result in engine damage.

- 2.1 Push the reset button on the air intake restriction indicator located on the air cleaner, if equipped.

- 2.2 Check the air intake duct from the air cleaner to the engine intake. Make sure the duct components are secure and airtight.

3. Check the engine oil level.

## NOTICE

Operating the engine with the oil level below the minimum fill (or "add") mark or above the maximum fill (or "full") mark could result in engine damage.

- 3.1 Check the oil level with the vehicle parked on a level surface. See the engine manufacturer's guidelines for engine shutdown time requirements prior to checking the oil level.

**IMPORTANT:** On engines that comply with EPA10 or newer regulations, use CJ-4 engine oil with less than 1% sulfated ash. Failure to use CJ-4 oil may void the warranty on emission aftertreatment components.

- 3.2 If the oil level is at or below the minimum fill (or "add") mark on the dipstick, add enough oil to maintain the level between the minimum and maximum fill marks. See the engine operation manual for recommended lubricants.

4. Check the power steering reservoir fluid level.

The power steering fluid level should be between the MIN COLD mark and the middle mark just above it. See [Fig. 20.4](#). If needed, fill the reservoir with automatic transmission fluid that meets Dexron III or TES-389 specifications.

## NOTICE

Low coolant could result in engine overheating, which could cause engine damage.

**IMPORTANT:** The surge tank must be cool to check the coolant level.

5. Check the engine coolant level in the radiator surge tank. See [Fig. 20.5](#).

# Pre- and Post-Trip Inspections and Maintenance

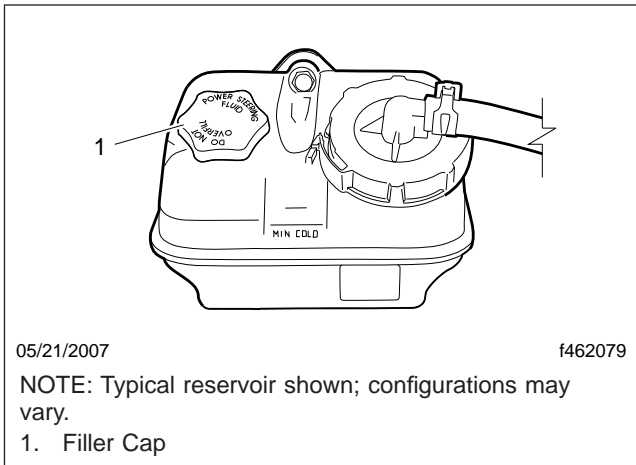


Fig. 20.4, Power Steering Fluid Reservoir

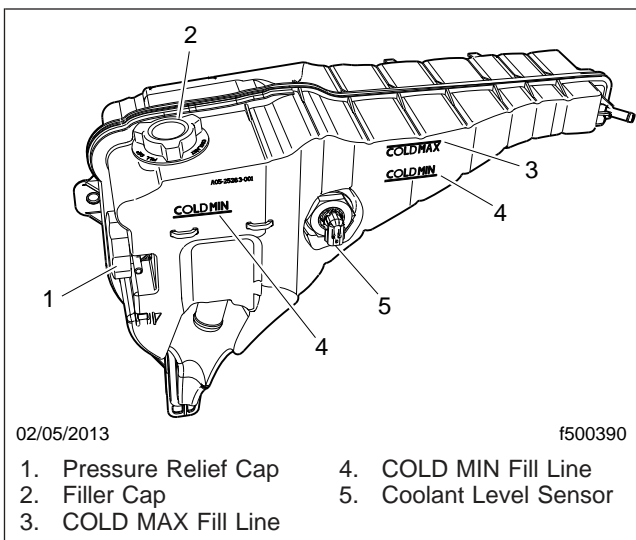


Fig. 20.5, Coolant Surge Tank

## NOTICE

**Coolant must be filled to the COLD MAX line of the surge tank. Low coolant could result in engine overheating, which could cause engine damage.**

- 5.1 If the coolant is low, fill the surge tank to the MAX line with a 50/50 mixture of water and the type of antifreeze currently installed in your vehicle.

- 5.2 If the surge tank was empty, start the engine after refilling and check the level again when the engine is at operating temperature.
6. Inspect visible engine wiring for damage or looseness. Check for loose wiring, chafed insulation, and damaged or loose hold-down clamps.
7. Inspect visible frame rails for missing bolts, shiny areas, or rust streaks.

## Cab Inspection

1. Push the reset button on the dash-mounted air intake restriction indicator, if equipped.
2. With the ignition switch in the OFF position, check the air-pressure warning system.
  - 2.1 If not previously drained, drain the air reservoirs using moderate brake applications until pressure in both reservoirs is less than 70 psi (483 kPa).
  - 2.2 Turn the ignition to the ON position. The ICU will complete a full gauge sweep and bulb check, and an audible warning will sound. Ensure the low air pressure lamp (BRAKE AIR) remains illuminated and an audible warning continues to sound after the gauge sweep is complete.
3. Check air governor cut-in and cut-out pressures.
  - 3.1 Start the engine and ensure the BRAKE AIR lamp goes out and the buzzer silences when pressure reaches approximately 70 psi (483 kPa) in both air reservoirs.

The air governor should cut out at approximately 120 psi (827 kPa). For vehicles with an optional dryer reservoir module (DRM), the cut-out pressure is approximately 130 psi (896 kPa).

- 3.2 With the engine idling, apply the brake pedal several times. The air governor should cut in when pressure in the primary air reservoir (top air gauge) reaches approximately 100 psi (689 kPa).
4. Check air pressure build-up time.

# Pre- and Post-Trip Inspections and Maintenance

- 4.1 With the air system fully charged, make one full brake application and note the air pressure reading on the primary air gauge.
- 4.2 Further reduce air pressure using moderate brake applications, then run the engine at governed rpm.
- 4.3 Note the time that the pressure reaches the previously noted reading on the primary air gauge, then note the time that the air pressure reaches cut-out pressure.
- 4.4 If it takes longer than 30 seconds to reach cut-out pressure after the primary air gauge passes the previously noted pressure (noted after one full brake application), eliminate any leaks or replace the air compressor before operating the vehicle.
5. Check air leakage in the system.
  - 5.1 With the parking brake applied, the transmission out of gear, and the air system fully charged, release the service brakes and shut down the engine.
  - 5.2 Wait one minute and note the air pressure drop in psi (kPa) per minute from the primary air reservoir.  
If the pressure drop exceeds the limits shown in [Table 20.1](#), eliminate any leaks before operating the vehicle.
6. Check the air pressure reserve.  
With the engine still off, make one full brake application and observe the pressure drop on the primary air gauge. If pressure drops more than 25 psi (172 kPa), eliminate any leaks before operating the vehicle.

| Maximum Allowable Air Leakage     |  |         |
|-----------------------------------|--|---------|
| Description                       | Pressure Drop:<br>psi (kPa) Per Minute |         |
|                                   | Released                               | Applied |
| Truck or Tractor Only             | 2 (14)                                 | 3 (21)  |
| Truck or Tractor w/Single Trailer | 3 (21)                                 | 4 (28)  |
| Truck or Tractor w/Two Trailers   | 5 (35)                                 | 6 (42)  |

Table 20.1, Maximum Allowable Air Leakage

## WARNING

**When cleaning windshields and windows, always stand on the ground or on a secure ladder or platform. Use a long-handled window cleaner. Do not use the cab steps, tires, fenders, fuel tanks, engine, or under-hood components to access the windshield or windows. Doing so could cause a fall and result in an injury.**

7. Inspect the mirrors, window glass, and windshield for cracks or other damage.
8. Ensure that the horn, windshield wipers, and windshield washers are operating properly. These devices must be in good working order for safe vehicle operation.
9. Ensure the heater and defroster are operating properly.
10. Check the operation of all interior lights.
  - 10.1 Turn on the headlights and leave them on. Ensure all equipped gauge bulbs illuminate in the dash message center.
  - 10.2 Ensure all equipped driver control switches illuminate.
  - 10.3 Ensure both turn signal indicator bulbs illuminate in the dash message center when the turn signal switch is activated.
11. Check the operation of all exterior lights. See [Fig. 20.6](#).
  - 11.1 Activate the high-beam headlights and hazard warning lights.
  - 11.2 Exit the cab and check that all exterior lights and reflectors are clean and intact.
  - 11.3 Check that the brake lights, taillights, headlights, turn signals, marker lights, identification lights, and clearance lights are working properly.
12. Inspect the seat belts and tether belts.

## WARNING

**Inspect and maintain seat belts. When any part of a seat belt system needs replacement, the entire seat belt must be replaced, both retractor and buckle side. Any time a vehicle is involved in an accident, and the seat belt system was in use,**

# Pre- and Post-Trip Inspections and Maintenance

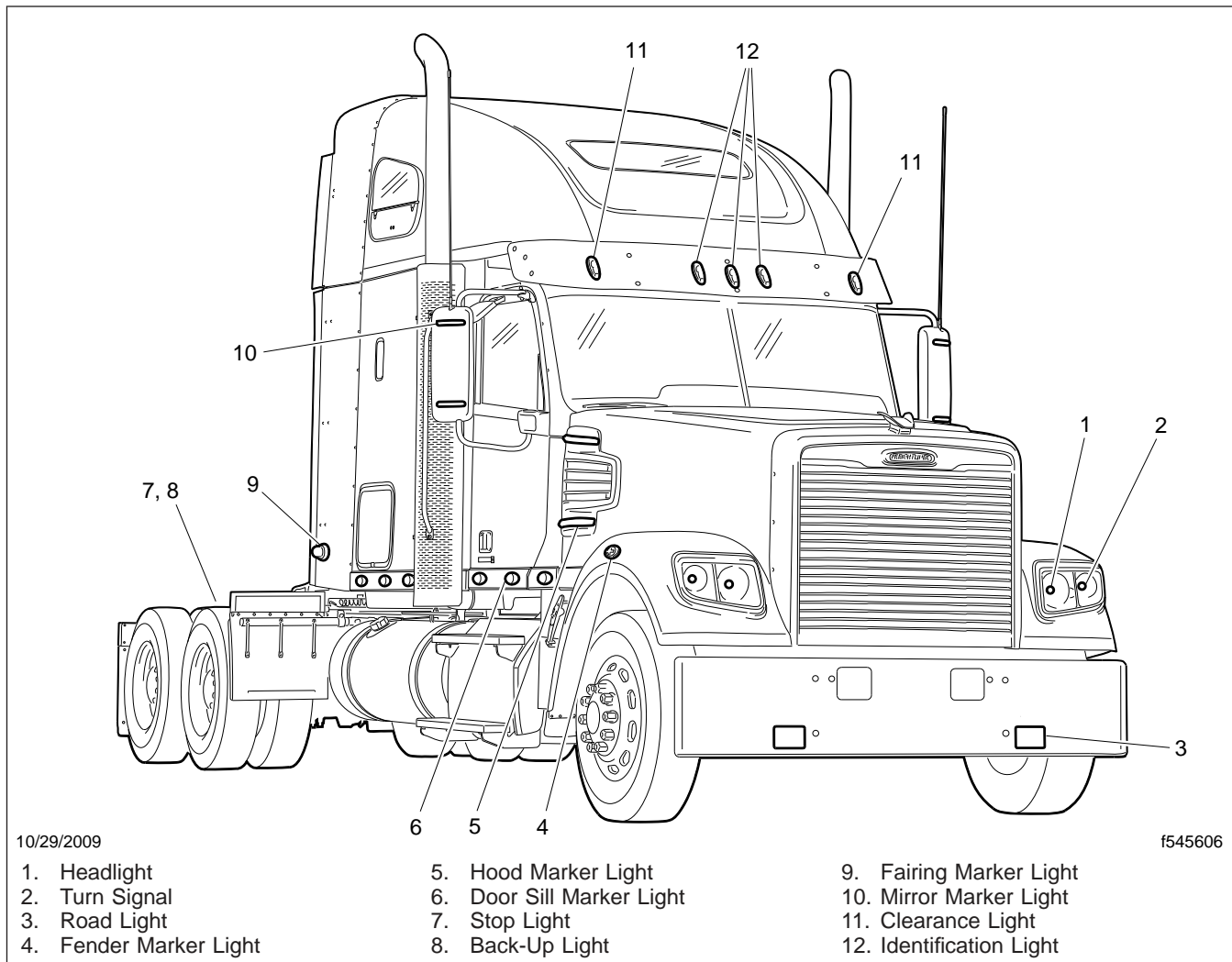


Fig. 20.6, Exterior Lights

**the entire vehicle seat belt system must be replaced before operating the vehicle. Do not attempt to modify the seat belt system; doing so could change the effectiveness of the system. Failure to replace worn or damaged seat belts, or making any modifications to the system, may result in personal injury or death.**

- 12.1 Check the web for fraying, cuts, extreme dirt and dust, or for severe fading from exposure to sunlight, especially near the buckle latch plate and in the D-loop guide area.

- 12.2 Check operation of the buckle, latch, Komfort Latch or Sliding Komfort Latch (if equipped), web retractor, and upper seat belt mount on the door pillar. Check all visible components for wear or damage.
- 12.3 Check the seat belt and tether belt connection points and tighten any that are loose.

**WARNING**

**Never fill fuel tanks to more than 95 percent of their liquid capacity. This could make them more**

# Pre- and Post-Trip Inspections and Maintenance

likely to rupture from impact, possibly causing fire and resulting in serious personal injury or death by burning.

**Do not mix gasoline or alcohol with diesel fuel. This mixture could cause an explosion, possibly resulting in serious personal injury or death. Do not fill the fuel tanks in the presence of sparks, open flames, or intense heat. These could ignite the fuel, possibly causing severe burns.**

**IMPORTANT:** On engines that comply with EPA10 or newer regulations, use ultralow-sulfur diesel (ULSD) with 15 ppm sulfur content or less. Failure to use ULSD fuel may void the warranty on emission components.

13. Check the fuel level in the fuel tank(s). To keep condensation to a minimum, fuel tanks should be filled at the end of each day.
14. Adjust the rearview and down view mirrors as necessary.
15. Test the service brakes.
  - 15.1 With the engine running and air system fully charged, set the parking brake.
  - 15.2 Put the vehicle in the lowest gear and gently attempt to move it forward. The vehicle should not move.

If the vehicle moves, the parking brakes are not operating correctly and must be repaired before the vehicle is operated.
16. Test the backup alarm.
  - 16.1 Release the parking brake and put the transmission in reverse.
  - 16.2 Move the vehicle slightly backward to ensure that the backup alarm is operating correctly.

## Weekly Post-Trip Inspection and Maintenance

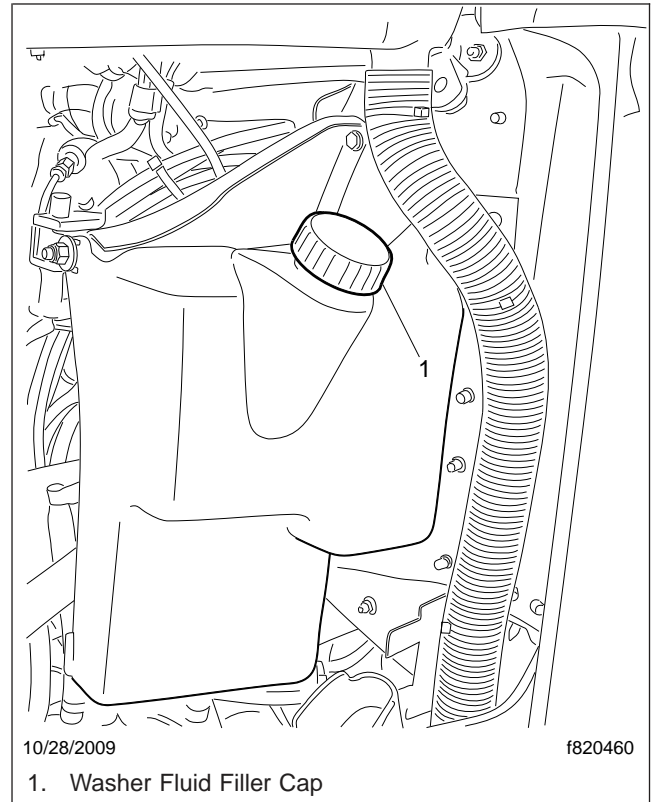
### Engine Compartment Inspection

#### **WARNING**

Washer fluids may be flammable and poisonous. Do not expose washer fluid to an open flame or any burning material, such as a cigarette. Always

comply with the washer fluid manufacturer's recommended safety precautions.

1. Check the windshield washer reservoir fluid level. The reservoir is usually located near the right-hand frame rail. See [Fig. 20.7](#).



**Fig. 20.7, Windshield Washer Reservoir**

2. After resetting the air intake restriction indicator during the daily pretrip inspection, check the indicator again with the engine off.
  - 2.1 Check an indicator with graduations to see if air restriction exceeds the value shown in [Table 20.2](#).

Check a go/no-go indicator without graduations to see if the colored bar shows through the clear window.

| Air Intake Maximum Restriction |                            |
|--------------------------------|----------------------------|
| Engine Make                    | Maximum inH <sub>2</sub> O |
| Cummins                        | 25                         |

# Pre- and Post-Trip Inspections and Maintenance

---

| Air Intake Maximum Restriction |                            |
|--------------------------------|----------------------------|
| Engine Make                    | Maximum inH <sub>2</sub> O |
| Detroit                        | 22                         |

Table 20.2, Air Intake Maximum Restriction

- 2.2 If air restriction exceeds the maximum allowable value, operate the vehicle for one more day, making sure not to run the engine over rated rpm. Refer to the engine operation manual for more information on rated rpm for your engine.
- 2.3 If air restriction exceeds the maximum value again, replace the air cleaner. For instructions, refer to **Group 09** of the *122SD and Coronado Workshop Manual*.
3. Inspect water evacuation components.
  - 3.1 Inspect the vacuator valve(s) installed on the hood interior and air cleaner. Make sure the lips of each valve are undamaged and pliable, free of debris, and remain closed during inspection. See [Fig. 20.8](#) and [Fig. 20.9](#).
  - 3.2 Inspect the rain tray installed at the base of the windshield. Ensure that the seal on the forward edge of the rain tray is in good condition.
  - 3.3 Inspect the drain hoses installed on the rain tray. Both hoses should be securely attached to the rain tray and direct water down the aft side of the front fenders. See [Fig. 20.7](#).
4. If the vehicle is equipped with an Allison automatic transmission, check the automatic transmission fluid level.
5. Check for water in the fuel/water separator, if equipped.

**IMPORTANT:** When draining fluid from a fuel/water separator, drain the fluid into an appropriate container and dispose of it properly. Many jurisdictions now issue fines for draining fuel/water separators onto the ground.

- 5.1 Place a suitable container under the fuel/water separator.

NOTE: A hose may be used to direct water into the container. Use a hose with a ½-inch pipe thread on DAVCO models.

- 5.2 If the engine is equipped with a built-in water separator, loosen the drain valve, and allow the water to run out. Close the drain valve, taking care not to overtighten it.
- 5.3 *Alliance/Racor Models:* Turn the drain plug counterclockwise to open it. See [Fig. 20.10](#).  
*DAVCO Models:* Remove the vent cap and open the drain. See [Fig. 20.11](#).
- 5.4 Stop draining fluid when fuel begins to drain out.  
*Alliance/Racor Models:* turn the drain plug clockwise to close it.  
*DAVCO Models:* close the drain valve. Install and hand-tighten the vent cap.
6. Inspect the steering components.
  - 6.1 Inspect tie rods, steering arms, and the drag link for signs of looseness (i.e., shiny spots or rust tracks). See [Fig. 20.12](#).
  - 6.2 Check the steering gear mounting bolts and pitman arm nut, if equipped, for signs of looseness.
  - 6.3 Check the drag link nuts for missing cotter pins.
  - 6.4 Inspect the steering intermediate shaft and end yokes for excessive looseness or other damage.

---

## NOTICE

---

**Do not drive with a drive belt that is visibly worn or damaged. If it fails, the lack of coolant flow could rapidly cause damage to engine components.**

7. Inspect the serpentine drive belts for signs of glazing, frayed edges, breaks, cracks, or oil contamination.



# Pre- and Post-Trip Inspections and Maintenance

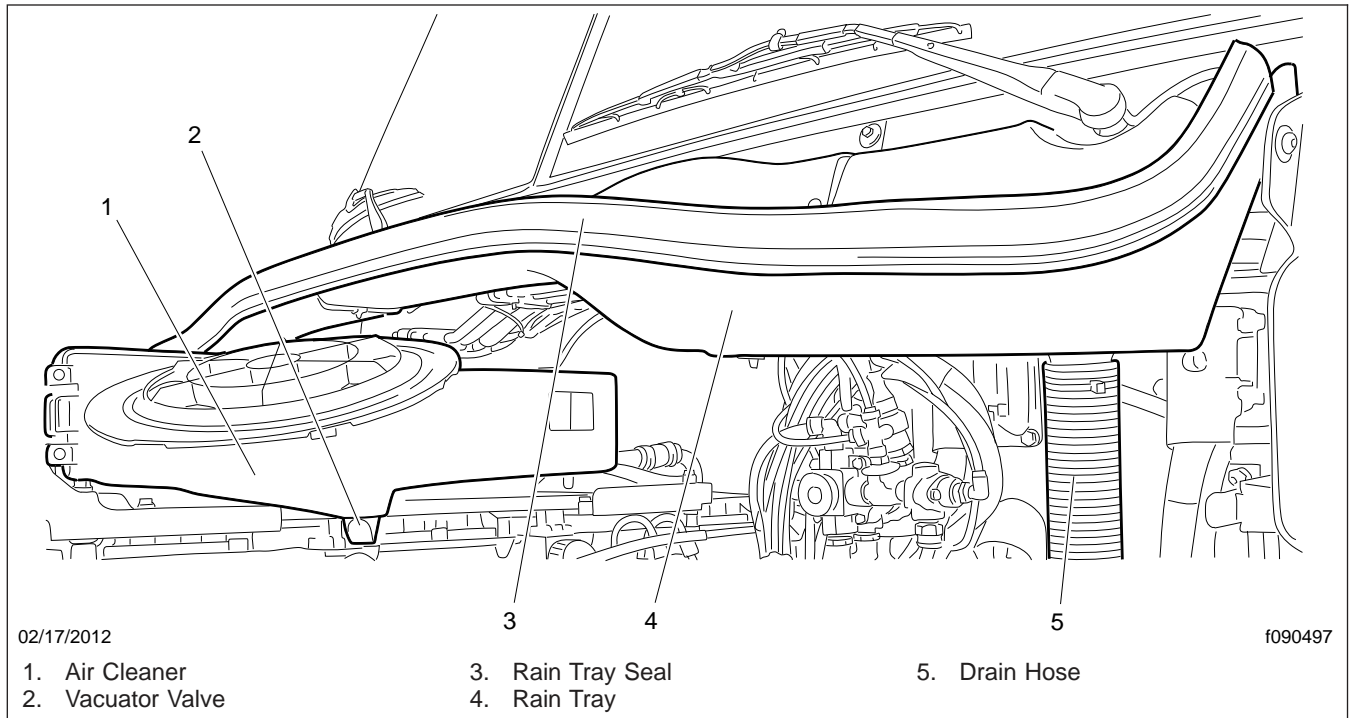


Fig. 20.8, Rain Tray Assembly

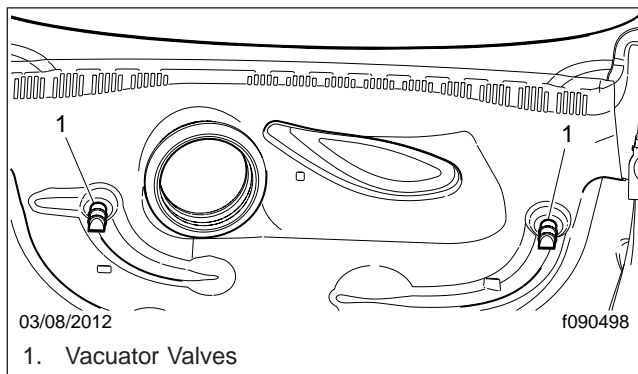


Fig. 20.9, Hood Interior

## Monthly Post-Trip Inspection and Maintenance

### Brake Component Inspection

Walk around the vehicle and inspect brake system components for visible damage.

1. Inspect all visible brake system components for missing fasteners or signs of looseness, such as rust tracks.

## NOTICE

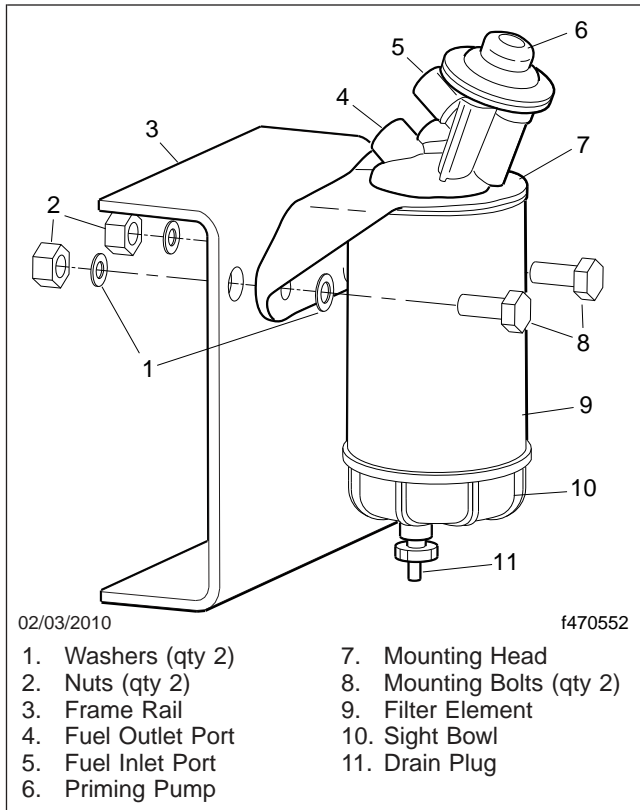
If the external breather tube or breather cap is missing or incorrectly installed, road dirt and debris can adversely affect the operation of the brake chamber. Once inside of the chamber, dirt and debris can cause the internal parts of the chamber to deteriorate faster.

2. Inspect the exterior surfaces of brake chambers for damage. Make sure that breather holes are open and free of debris.

NOTE: Do not route air brake lines on top of anything likely to be stepped on.

3. Inspect air brake lines for dents, swelling, kinks, twisting, abrasion, and damage, especially near moving parts.
4. Inspect flex air lines for deterioration or signs of abrasion.
5. Inspect for cracked, worn, or oil-contaminated brake linings and brake drums (or rotors).

# Pre- and Post-Trip Inspections and Maintenance



**Fig. 20.10, Alliance Fuel/Water Separator Assembly and Installation**

6. Check the thickness of the brake linings. Replace brake linings on all brake assemblies on the axle if any brake linings are worn to less than approximately 1/4 inch (6.4 mm) at the thinnest point.

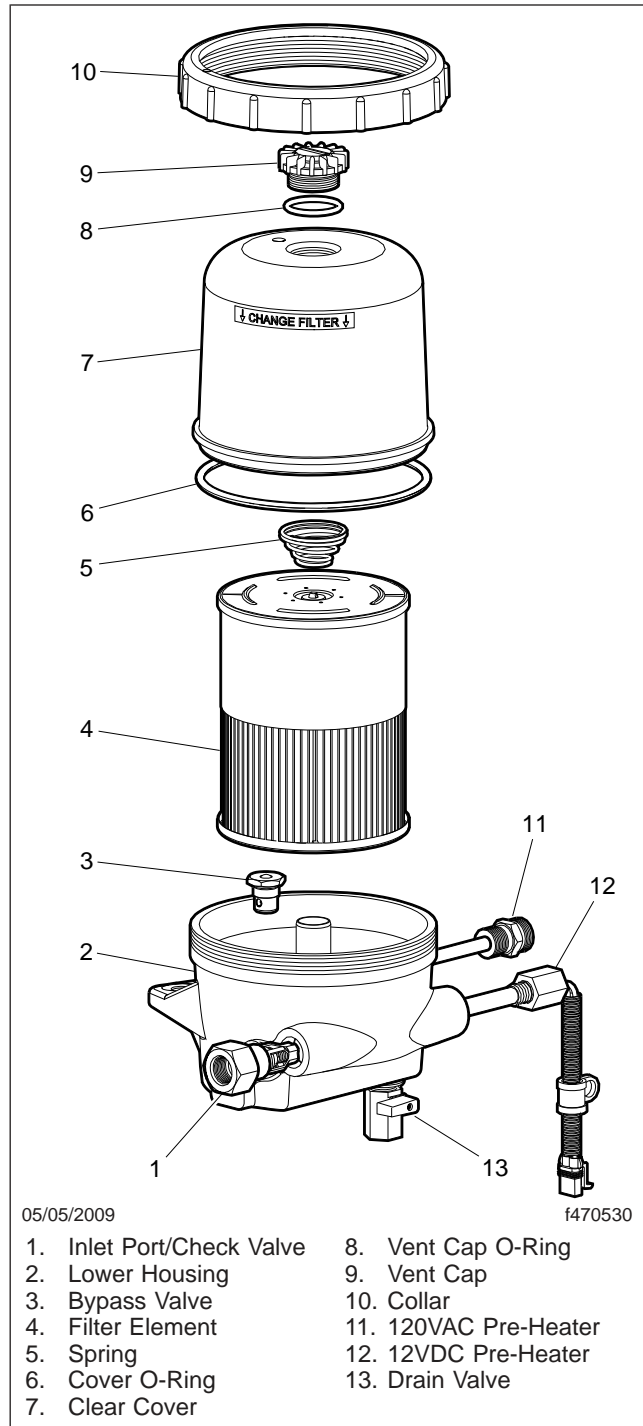
## Saddle Tank Areas Inspection

### **WARNING**

When draining the air reservoir, do not look into the air jets or direct them toward anyone. Dirt or sludge particles may be in the airstream and could cause injury.

### **NOTICE**

If the water drained from the air reservoirs is cloudy or oily, it may indicate a problem with the compressor. If oil is allowed to contaminate the air dryer, it will not remove the water from the air



**Fig. 20.11, DAVCO Fuel/Water Separator (Fuel Pro 482 shown)**

# Pre- and Post-Trip Inspections and Maintenance

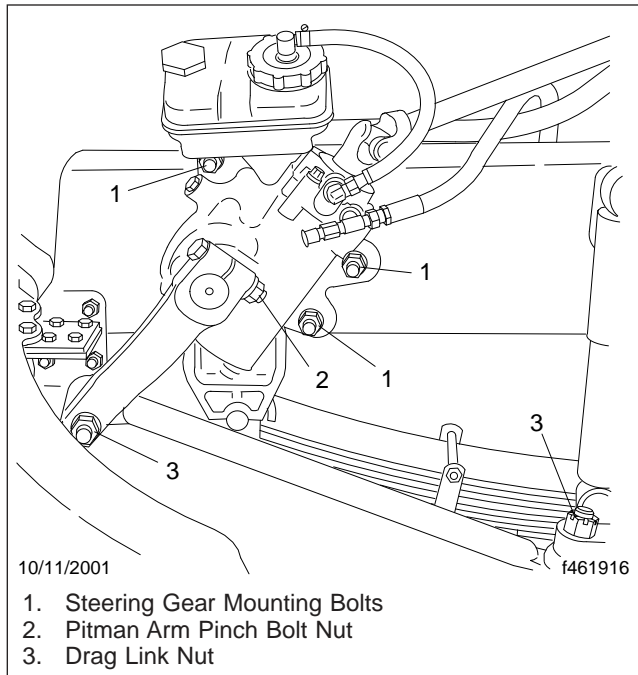


Fig. 20.12, Integral Steering Gear Fasteners

**brake system, which could adversely affect braking.**

1. Drain the brake system air reservoirs (reservoirs with automatic drain valves only).

NOTE: Battery locations vary between vehicles.

2. Inspect the batteries.

## **WARNING**

**Battery posts, terminals, and related accessories contain lead and lead compounds, chemicals known to the State of California to cause cancer and reproductive harm. To prevent possible personal injury, always wash your hands after handling battery parts and related accessories.**

- 2.1 Remove the battery box cover and inspect all visible battery cables for loose wiring or damage.
- 2.2 Check that the battery hold-down is secure.

**IMPORTANT:** Aerodynamic components decrease drag force as a vehicle moves, thereby improving fuel efficiency. If replacement of an

aerodynamic component is necessary, replacement components must meet or exceed the drag reduction performance of the originally installed component in order to maintain compliance with greenhouse gas and full efficiency regulations (GHG14).

3. Inspect the following aerodynamic components, if equipped, for structural damage, cracks, or wear.
  - Chassis fairings
  - Roof fairing/deflector
  - Side skirts
  - Cab/sleeper extenders
  - Battery access cover

## Engine Compartment Inspection and Adjustments

**IMPORTANT:** If replacement of the hood or bumper is necessary, the replacement component must meet or exceed the drag reduction performance of the originally installed item in order to maintain compliance with greenhouse gas and full efficiency regulations (GHG14).

1. Inspect the bumper and hood for structural damage, cracks, or wear.
2. Check the hydraulic clutch reservoir, if equipped. If necessary, add DOT 4 brake fluid.
3. Inspect the radiator and heater hoses, including the clamps and support brackets.
  - 3.1 Inspect the radiator and charge air cooler for damage and accumulated debris. Straighten bent or damaged fins to permit airflow across all areas of the cores.

NOTE: When traveling through areas of high insect concentration, it may be necessary to clean the exterior of the radiator or the charge air cooler core as often as every 200 miles (320 km).

- 3.2 Make sure the radiator inlet and outlet hoses are pliable and are not cracking or ballooning.
- 3.3 Make sure the heater hoses are pliable and are not cracking or ballooning.

# Pre- and Post-Trip Inspections and Maintenance

---

3.4 Tighten hose clamps as necessary.

**IMPORTANT:** Do not overtighten hose clamps, as hose life can be adversely affected.

3.5 Ensure hose support brackets are securely fastened. Make sure hoses are not located near sources of wear, abrasion, or high heat.

**IMPORTANT:** When replacing hoses, install service-type knitted or braided yarn-reinforced neoprene hose. Extended-service-life silicone hoses may also be used. See the Alliance Parts Catalog at [www.alliancebrandparts.com](http://www.alliancebrandparts.com) or contact your Freightliner Dealer.

4. Check the steering wheel for excessive play.

4.1 Start the engine. With the front tires straight ahead, turn the steering wheel until motion is observed at the front wheels.

4.2 Align a reference mark on the steering wheel to a rule, then slowly turn the steering wheel in the opposite direction until motion is again detected at the wheels.

4.3 Measure the lash (free play) at the rim of the steering wheel. Excessive lash exists if steering wheel movement exceeds 2-1/2 inches (64 mm) with a 20-inch (508-mm) steering wheel, or 2-1/4 inches (57 mm) with an 18-inch (450-mm) steering wheel.

4.4 If there is excessive lash, check the steering system for wear or incorrect adjustment before operating the vehicle.

# 21

## Cab Appearance

---

|                                  |      |
|----------------------------------|------|
| Cab Washing and Polishing .....  | 21.1 |
| Care of Fiberglass Parts .....   | 21.1 |
| Care of Chrome Parts .....       | 21.1 |
| Care of Exterior Lights .....    | 21.1 |
| Dashboard Care .....             | 21.1 |
| Vinyl Upholstery Cleaning .....  | 21.2 |
| Velour Upholstery Cleaning ..... | 21.3 |

# Cab Appearance

---

## Cab Washing and Polishing

**IMPORTANT:** Carefully read all instructions before using or applying any cleaner or product on the vehicle or components. Failure to follow manufacturers' recommendations can result in damage to the finish.

To protect the finish of your new vehicle, follow these guidelines carefully.

- During the first 30 days, rinse your vehicle frequently with water. If the vehicle is dirty, use a mild liquid soap. Do not use detergent.
- During the first 30 days, do not use anything abrasive on your vehicle. Brushes, chemicals, and cleaners may scratch the finish.
- During the first 120 days, do not wax your vehicle.

To extend the life of your vehicle's finish, follow these guidelines.

- Avoid washing your vehicle in the hot sun.
- Always use water. After the cab is completely washed, dry it with a towel or chamois.
- Do not dust painted surfaces with a dry cloth, as this will scratch the paint.
- Do not remove ice or snow from a painted surface with a scraper of any sort.
- To prevent damage to the finish, wax it regularly. Before waxing, if the finish has become dull, remove oxidized paint using a cleaner specifically designed for this purpose. Remove all road tar and tree sap before waxing. Freightliner recommends that a quality brand of cleaner or cleaner-polish and polishing wax be used.
- Do not let diesel fuel or antifreeze stand on a painted surface. If either should occur, rinse the surface off with water.
- To prevent rust, have any nicks or other damage on the finish touched up as soon as possible.
- Park your vehicle in a sheltered area whenever possible.

## Care of Fiberglass Parts

Wash unpainted fiberglass air fairings and shields monthly with a mild detergent, such as dishwashing liquid. Avoid strong alkaline cleansers.

Apply a wax specifically designed for fiberglass.

## Care of Chrome Parts

To prevent rust, keep chrome parts clean and protected at all times. This is especially important during winter driving and in coastal areas where there is exposure to salt air.

When cleaning chrome parts, use clean water and a soft cloth or sponge. A mild detergent may also be used.

Sponge gently, then rinse. If necessary, use a non-abrasive chrome cleaner to remove stubborn rust or other material. Do not use steel wool.

To help protect the chrome after cleaning, apply a coat of polishing wax to the surface. Never use wax on parts that are exposed to high heat, such as exhaust pipes.

## Care of Exterior Lights

Clean the headlight lenses by hand only, using a flannel cloth with mild, non-caustic soap or detergent, and water.

---

### NOTICE

---

**Do not use a power buffer, paper towels, chemical solvents, or abrasive cleaners on the headlight lens, all of which can remove the UV coating from the surface, and result in yellowing of the lens.**

## Dashboard Care

---

### NOTICE

---

**When cleaning the dashboard, instrument panel, or gauge lens covers, do not use Armor-All Protectant®, STP Son-of-a-Gun®, window cleaner, or other equivalent treatments. These cleaners contain vinyl plasticizers which can cause stress crazing in the interior plastic panels and can result in cracking of the panels. Some cleaners can**

**also have an adverse effect on the clear plastic of instrument panels and gauge lens covers, resulting in a foggy or cloudy appearance. This type of damage is not covered by vehicle warranty.**

To clean the dashboard, instrument panel, and gauge lens covers, use a cloth dampened with warm soapy water. Make certain to wring the cloth out well before cleaning, as excess water will damage the electrical components.

## Vinyl Upholstery Cleaning

To prevent soiling, frequent vacuuming or light brushing to remove dust and dirt is recommended. Harsh cleaning agents can cause permanent damage to vinyl upholstery. To preserve the upholstery and prevent damage, carefully review the following sections for recommended cleaning procedures. Waxing or refinishing improves soil resistance and cleanability for all vinyls. Any hard wax, such as that used on automobiles, may be used.

### Ordinary Dirt

Wash the upholstery with warm water and mild soap, such as saddle or oil soap. Apply soapy water to a large area and allow to soak for a few minutes, then rub briskly with a cloth to remove the dirt. This can be repeated several times, as necessary.

If dirt is deeply imbedded, use a soft bristle brush after applying the soap.

If dirt is extremely difficult to remove, wall-washing preparations normally found around the home can be used. Powdered cleaners, such as those used for sinks and tiles, are abrasive and must be used with caution as they can scratch the vinyl or give it a permanent dull appearance.

### Chewing Gum

Harden the gum with an ice cube wrapped in a plastic bag, then scrape it off with a dull knife. Any remaining traces of gum can be removed with an all-purpose light oil (peanut butter will also work) and wiped off.

### Tars, Asphalts, and Creosote

Each of these items stains vinyl after prolonged contact. They should be wiped off immediately and the

area carefully cleaned, using a cloth dampened with naphtha.

### Paint, Shoe Heel Marks

Paint should be removed immediately. Do not use paint remover or liquid-type brush cleaner on vinyl. An unprinted cloth, dampened with naphtha or turpentine may be used. Use care to prevent contact with parts of the upholstery that are not vinyl.

### Sulfide Stains

Sulfide compounds, such as those found in eggs and some canned goods, can stain after prolonged contact with vinyl. These stains can be removed by placing a clean, unprinted piece of cloth over the spotted area and pouring a liberal amount of 6 percent hydrogen peroxide onto the cloth. Allow the saturated cloth to remain on the spot for 30 to 60 minutes. For stubborn spots, allow the hydrogen-peroxide saturated cloth to remain on the area overnight. Use caution to prevent the solution from seeping into the seams, or it will weaken the cotton thread.

### Nail Polish and Nail Polish Remover

Prolonged contact with these substances causes permanent damage to vinyl. Careful blotting immediately after contact minimizes damage. Do not spread the liquid during removal.

### Shoe Polish

Most shoe polishes contain dyes which penetrate vinyl and stain it permanently. Shoe polish should be wiped off as quickly as possible using naphtha or lighter fluid. If staining occurs, try the procedure used for sulfide stains.

### Ball Point Ink

Ball point ink can sometimes be removed if rubbed immediately with a damp cloth, using water or rubbing alcohol. If this does not work, try the procedure used for sulfide stains.

### Miscellaneous

If stains do not respond to any of the treatments described above, it is sometimes helpful to expose the vinyl to direct sunlight for up to 30 hours. Mustard, ball point ink, certain shoe polishes, and dyes often

# Cab Appearance

---

bleach out in direct sunlight, leaving the vinyl undamaged.

## Velour Upholstery Cleaning

To prevent soiling, frequent vacuuming or light brushing to remove dust and dirt is recommended. Spot clean with a mild solvent or an upholstery shampoo, or the foam from a mild detergent. When using a solvent or a dry-cleaning product, follow the instructions carefully, and clean only in a well-ventilated area. Avoid any product that contains carbon tetrachloride or other toxic materials. With either method, pretest a small area before proceeding. Use a professional upholstery cleaning service when extensive cleaning is needed.

## Grease and Oil-Based Stains

Dampen a small absorbent cloth with dry-cleaning solvent or spot remover. Apply the cloth carefully to the spot from the outer edge to the center. Pat and blot the spot with a clean, dry cloth. Repeat several times, as necessary, turning the cloths so that the stain does not redeposit on the fabric.

## Sugar and Water-Based Stains

Apply water-based detergent or cleaner, working in circular motions. Pat and blot as dry as possible. Repeat, if necessary, before drying thoroughly.

## Chewing Gum or Wax

Harden the gum or wax with an ice cube wrapped in a plastic bag, then scrape it off with a dull knife. Excess wax can be absorbed by placing a thick white blotter over the wax and heating with a warm (not hot) iron. Remove the remainder by using the procedure for grease and oil-based stains.

## Mildew

Brush the dry fabric with a soft brush. Sponge with detergent, and blot. If the fabric is colorfast, dilute a teaspoon of bleach in one quart (one liter) of cool water. Apply with a swab, directly on the mildew stain. Dab repeatedly with clear, cool water, and blot dry.



# 22

## Headlight Aiming

---

|                               |      |
|-------------------------------|------|
| Preliminary Checks .....      | 22.1 |
| Checking Headlight Aim .....  | 22.1 |
| Adjusting Headlight Aim ..... | 22.1 |

# Headlight Aiming

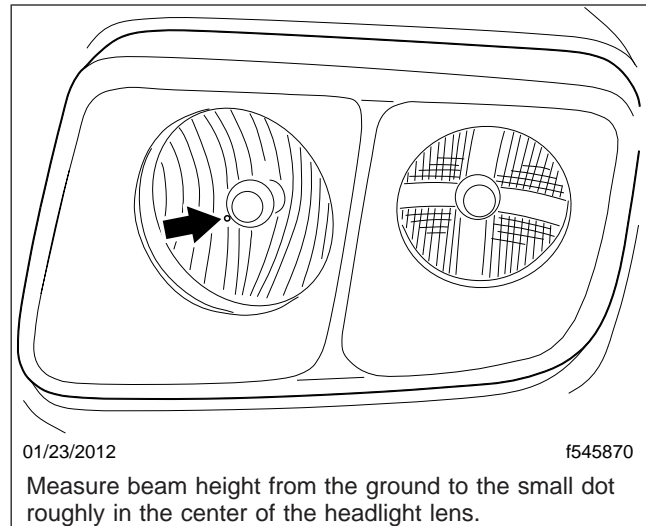
## Preliminary Checks

Before checking or adjusting the headlight aim, complete the following inspection:

- Check that the hood is closed and latched.
- Remove any large amounts of mud or ice from the underside of the fenders.
- Check the springs for sagging or broken leaves.
- Check the suspension for proper functioning of the leveling mechanism. If the vehicle is equipped with an air suspension, make sure that the height is properly adjusted.
- Check for damage to the hood and hinge assembly. Repair as necessary.
- With the vehicle unloaded, check that the tires are inflated to the recommended air pressure.
- Clean the headlight lenses. Use a soft cloth with mild, non-caustic soap or detergent, and water.

## Checking Headlight Aim

1. Park the vehicle on a level surface, 25 ft (7.6 m) away from, and perpendicular to, a vertical screen or wall. Shut down the engine and set the parking brake. Chock the tires.
2. Each headlight has a height adjusting dot. See [Fig. 22.1](#). Measure the distance from the ground to the height adjusting dot on each headlight ([Fig. 22.2](#), Item A). Note those distances.
3. On the screen or wall, mark the locations of each headlight bulb center using the distances found in step 2. See [Fig. 22.2](#), Items 2 and 3.
4. Turn on the low-beam headlights.
5. Check the vertical adjustment of the low beams. The center of each beam projection should fall on or near the marks made during step 3. See [Fig. 22.3](#).
6. Use [Table 22.1](#) to determine the maximum vertical distance allowable between the marks on the wall and the center of each low-beam projection.  
If the distance between either projection center and the mark made on the wall or screen is greater than the maximum distance given in



**Fig. 22.1, Headlight Beam Height Adjusting Dot**

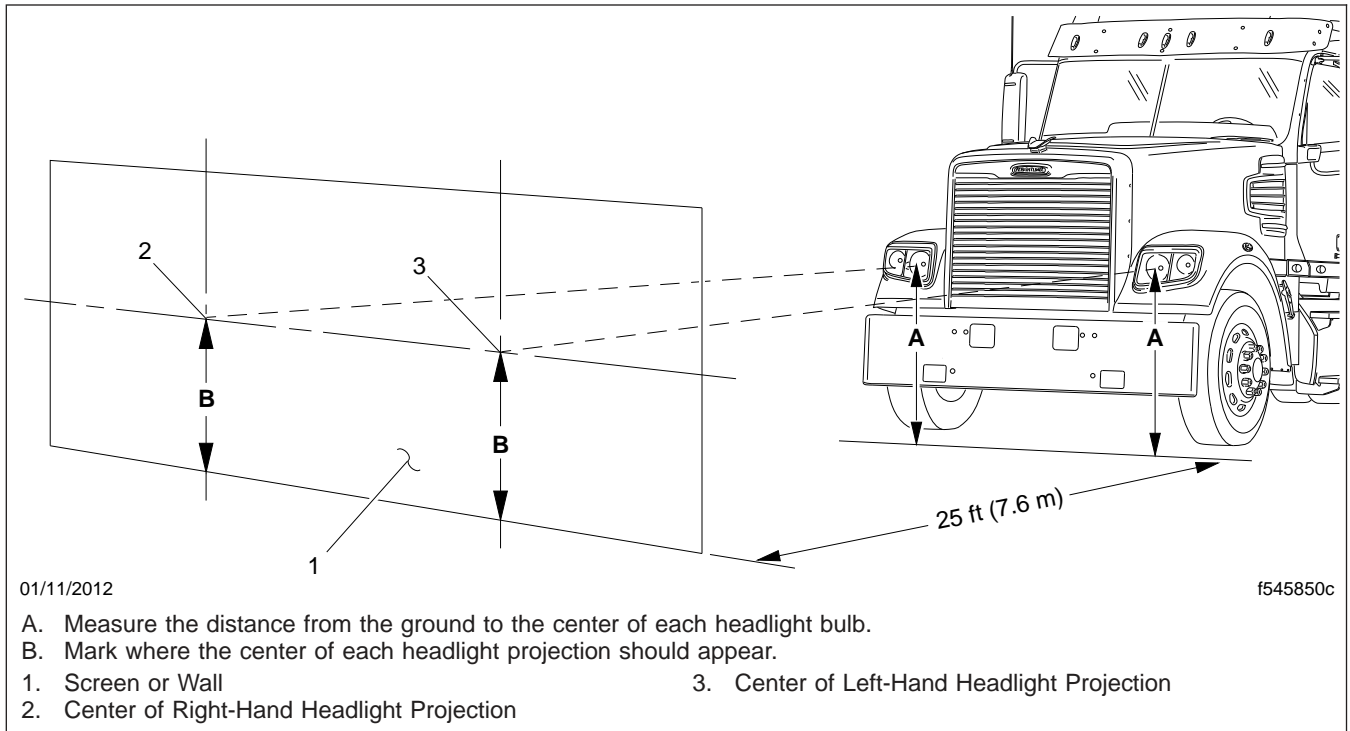
[Table 22.1](#), adjust the vertical positioning of that headlight.

## Adjusting Headlight Aim

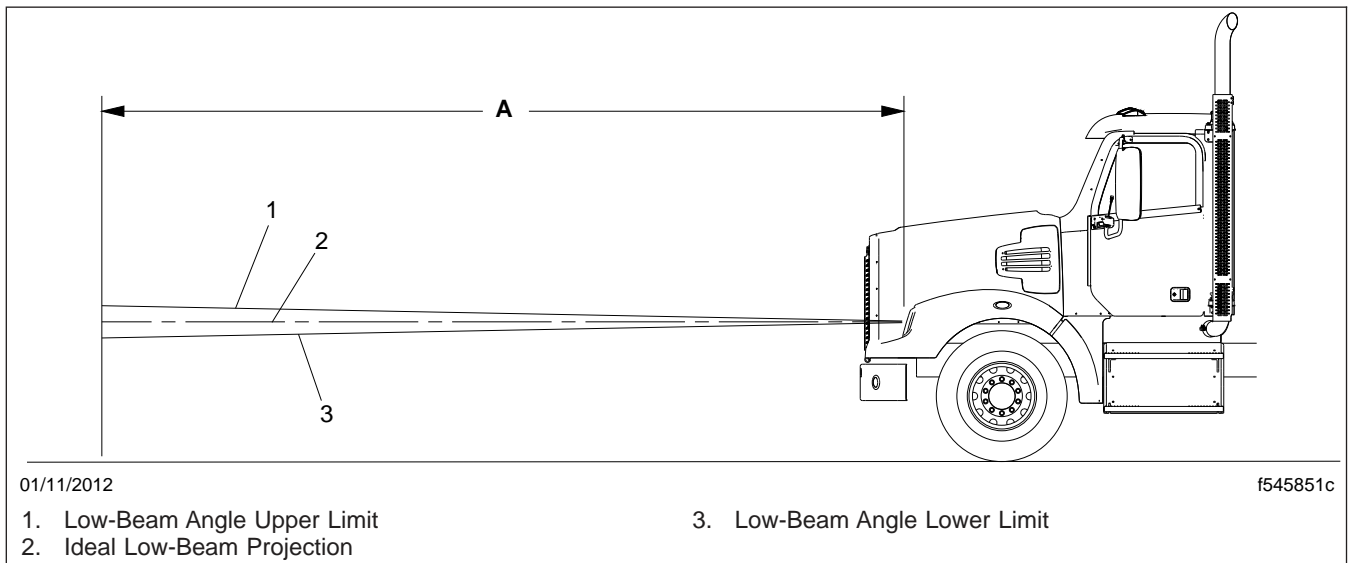
NOTE: Freightliner vehicles are offered with various headlight assembly options. Because of the various options, the location of adjustment screws on your vehicle's headlight assembly may vary from what is shown here.

The adjusting screw is located on the upper inboard corner of the headlight assembly. See [Fig. 22.4](#). Turn the adjusting screw clockwise to raise the beam and counterclockwise to lower it, until the beam pattern meets the acceptable standard.

# Headlight Aiming

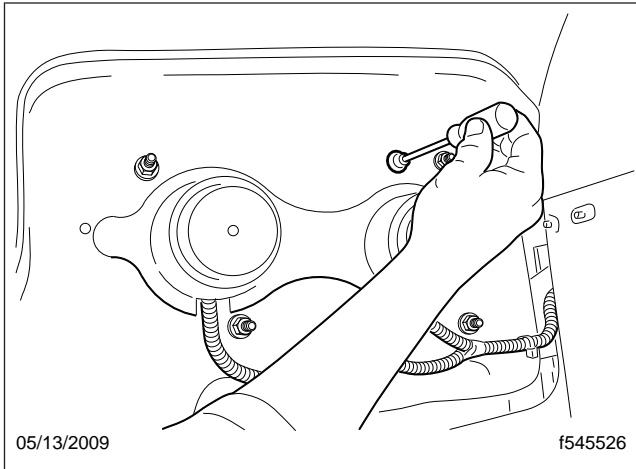


**Fig. 22.2, Headlight Aiming Screen/Wall**



**Fig. 22.3, Vertical Low-Beam Headlight Variation Limits**

# Headlight Aiming



**Fig. 22.4, Headlight Adjusting**

| Vertical Low-Beam Headlight Variation Limits   |  |   |   |
|--|--|---|---|
| Distance Between Ground and Headlight: in (mm) | Desired Variation (Fig. 22.3, Item 2): in (mm) | Upper Limit (Fig. 22.3, Item 1): in (mm) up | Lower Limit (Fig. 22.3, Item 3): in (mm) down |
| 22–36 (560–900)                                | 0  | 3.9 (100)                                   | 3.9 (100)                                     |
| 36–48 (900–1200)                               | 2 (50) down                                    | 2 (50)                                      | 6 (150)                                       |
| 48–54 (1200–1400)                              | 2.5 (64) down                                  | 1.6 (40)                                    | 6.5 (165)                                     |

**Table 22.1, Vertical Low-Beam Headlight Variation Limits**

# 23

## In an Emergency

---

|   |      |
|---|------|
| Hazard Warning Lights .....                 | 23.1 |
| Fire Extinguisher .....                     | 23.1 |
| Emergency Kit, Optional .....               | 23.1 |
| Emergency Starting With Jumper Cables ..... | 23.1 |
| Towing .....                                | 23.2 |
| Fire in the Cab .....                       | 23.4 |

# In an Emergency

## Hazard Warning Lights

The hazard warning light switch tab is located under the turn-signal control lever. See [Fig. 23.1](#). To operate the hazard lights, pull the tab out. All of the turn signal lights and both of the indicator lights on the control panel will flash.

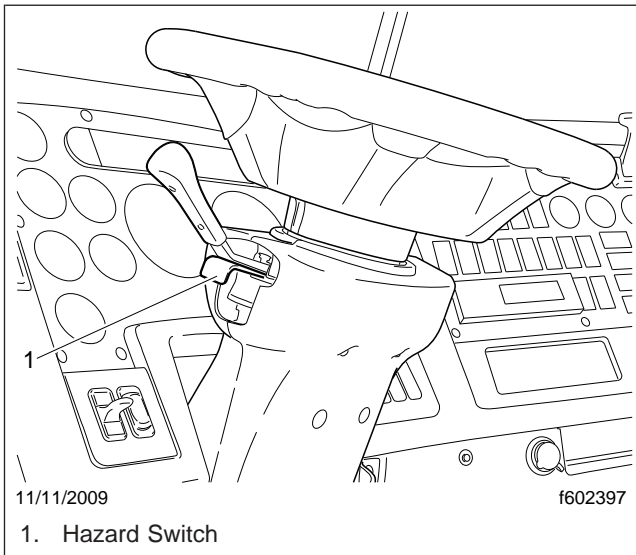


Fig. 23.1, Hazard Warning Light Switch

To cancel the hazard warning lights, push the turn signal control lever either up or down, then return the lever to its neutral position.

## Fire Extinguisher

A fire extinguisher is located either in the cab by the driver's door, or in the baggage compartment.

## Emergency Kit, Optional

An optional emergency kit is located in the cab. The kit includes one or more of the following: a first aid kit, a reflective vest, a triangular reflector, a flare kit, and (on vehicles with a Davco fuel/water separator) a spin-on fuel filter element.

If there is an emergency while driving, cautiously pull off the road. Turn on the hazard warning lights. Place the flares and reflector along the side of the road to alert other drivers that an emergency situation exists.

### WARNING

Use extreme care when placing flares in emergency situations that involve exposure to flammable substances such as fuel. An explosion or fire could occur causing serious personal injury.

## Emergency Starting With Jumper Cables

When using jumper cables, follow the instructions below.

### WARNING

Batteries release explosive gas. Do not smoke when working around batteries. Put out all flames and remove all sources of sparks or intense heat in the vicinity of the battery. Do not allow the vehicles to touch each other. Do not lean over the batteries when making connections, and keep all other persons away from the batteries. Failure to follow these precautions could lead to severe personal injury as a result of an explosion or acid burns.

### NOTICE

Make sure both electrical systems are the same voltage. Electronic devices on both vehicles can be damaged when connected to a vehicle with a different operating voltage.

NOTE: On vehicles equipped with optional jump-start posts, connect to the posts instead of the batteries.

1. Apply the parking brakes and turn off the lights and all other electrical devices.
2. Remove the battery box cover, and the inner cover, to expose the battery posts. See [Chapter 3](#) for instructions.

### NOTICE

Always connect the battery, jumper cables, and charger correctly (positive-to-positive and

negative-to-negative). Connecting a charging device backwards (positive-to-negative) can severely damage the vehicle electrical content and cause non-warrantable failures.

3. Connect the positive (+) jumper cable to the positive battery post on the vehicle needing the jump start, then connect the other end of the positive jumper cable to the positive battery or jump start post of the vehicle providing the jump. See Fig. 23.2.

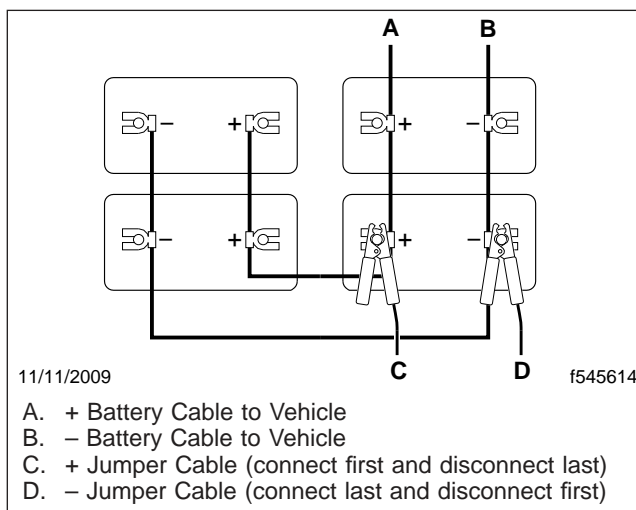


Fig. 23.2, Jumper Connections

## WARNING

Do the next step exactly as instructed and do not allow the clamps of one cable to touch the clamps of the other cable. Otherwise, a spark could occur near a battery, possibly resulting in severe personal injury from explosion or acid burns.

4. Connect one end of the second jumper cable to the negative terminal of the booster battery, and connect the other end of the cable to the negative battery post of the vehicle needing the jump start.
5. Start the engine of the vehicle with the booster batteries, and let the engine run a few minutes to charge the batteries of the other vehicle.
6. Attempt to start the engine of the vehicle with the batteries receiving the charge. Do not operate the starter longer than 30 seconds, and wait at

least two minutes between starting attempts to allow the starter to cool.

7. When the engine starts, let it idle a few minutes.

## WARNING

Do the next step exactly as instructed and do not allow the clamps of one cable to touch the clamps of the other cable. Otherwise, a spark could occur near a battery, possibly resulting in severe personal injury from explosion or acid burns.

8. Disconnect the grounded cable from the frame or other non-battery location, then disconnect the other end of the cable.
9. Disconnect the remaining cable from the newly charged battery (or jump-start post if equipped) first, then disconnect the other end.
10. Install the cover; be sure it is positioned properly before fastening the latch.

## Towing

When it is necessary to tow the vehicle, make sure the instructions below are closely followed to prevent damage to the vehicle.

## WARNING

Do not tow an unbraked vehicle if the combined weight of both vehicles is more than the sum of the gross axle weight ratings (GAWR) of the towing vehicle. Otherwise brake capacity will be inadequate, which could result in personal injury or death.

## Front Towing Hookup

1. Disconnect the battery ground cables.

## NOTICE

Failure to remove the axle shafts when towing the vehicle with the rear wheels on the ground could result in damage to the transmission and other parts.

2. Remove both drive axle shafts. On dual drive axles, if the vehicle is to be lifted and towed, remove only the rearmost drive axle shafts.

# In an Emergency

---

On vehicles equipped with an air fairing, remove both the forward and rearmost drive axle shafts if there is insufficient towing clearance.

3. Cover the ends of the hubs with metal plates or plywood cut to fit the axle opening, and drilled to fit the axle shaft studs. This prevents lubricant from leaking out and will keep contaminants from getting into and damaging the wheel bearings and axle lubricant.

---

## NOTICE

---

**Failure to protect the frame rails from the chains could cause damage, leading to eventual frame failure.**

4. On dual drive axles, if the vehicle is to be lifted and towed, chain the forward rear-axle assembly to the vehicle frame. Use protection to keep the chains from damaging the frame.
5. Remove the bumper end caps and chrome bumper (if equipped).
6. Attach the towing device. Do not pass a sling (for example, a rope or chain) from one tow hook to another to fasten for towing. Known as reeving, this practice is not permissible in most industrial applications of towing and hoisting. Reeving can overload the hooks and result in damage to the vehicle. See [Fig. 23.3](#).
7. Lift the vehicle and secure the safety chains. If extra towing clearance is needed, remove the front wheels.

**NOTE:** Due to the many variables that exist in towing, positioning the lifting and towing device is the sole responsibility of the towing-vehicle operator.

8. Connect the clearance lights, taillights, and signal lights. Connect any special towing lights required by local regulations.

 **WARNING**

**Failure to chock the tires or connect the tow truck's air brake system before releasing the spring parking brakes could allow the disabled vehicle to suddenly roll. This could cause property damage or personal injury.**

9. Chock the tires on the disabled vehicle and connect the towing vehicle's air brake system to the vehicle being towed. Then, release the spring parking brakes and remove the chocks.

## Rear Towing Hookup

---

### NOTICE

---

**Using a rear towing hookup on a vehicle equipped with a roof fairing could cause damage to the cab structure.**

**If reverse towing at speeds above 45 mph (70 kph) is necessary, hold down the cab with tension straps looped over the cab shocks and under the frame rails. Failure to do so could allow the wind load to lift the cab unexpectedly, resulting in damage to the air springs and other components.**

1. If the vehicle is equipped with cab air suspension, and reverse towing at speeds above 45 mph (70 kph) is necessary, hold down the cab as follows:
  - 1.1 Drain the air from the cab air springs.
  - 1.2 Loop a 2-inch (5-cm) ratchet-style tension strap (rated 2000 lb [900 kg] minimum work load) over the top of the cab shock and under the frame rail. See [Fig. 23.4](#). Tighten the strap for a snug fit. If the cab is equipped with two or more shocks, restrain the aftmost shock on each side of the vehicle.
2. Place the front tires straight forward and secure the steering wheel in this position.
3. Disconnect the battery ground cables.

---

### NOTICE

---

**Failure to protect the frame rails from the chains could cause damage, leading to eventual frame failure.**

4. On dual drive axles, using protection to keep the chains from damaging the vehicle frame, chain the forward-rear drive axle to the frame.
5. Attach the towing device.



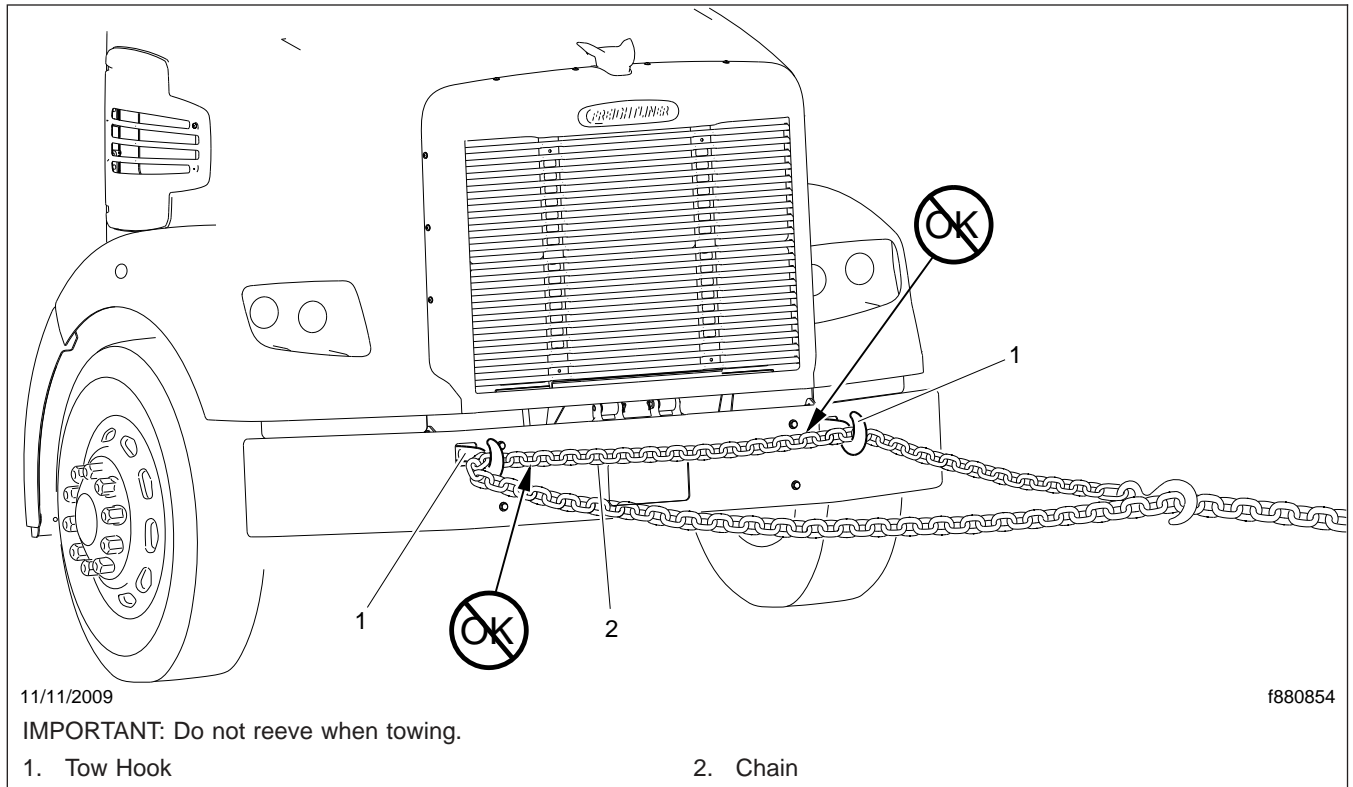


Fig. 23.3, Reeving

NOTE: Due to the many variables that exist in towing, positioning the lifting and towing device is the sole responsibility of the towing-vehicle operator.

6. Lift the vehicle and secure the safety chains. If extra clearance is needed, remove the bumper extension if equipped.
7. Connect the clearance lights, taillights, and signal lights. Also connect any special towing lights required by local regulations.

## Fire in the Cab

The incidence of fire in heavy- and medium-duty trucks is rare, according to data from the National Highway Traffic Safety Administration. Federal Motor Vehicle Safety Standard #302 limits the flammability of specified materials used inside the cab, but despite this, most materials will burn. The cab of this vehicle contains urethane foam, which is of concern in this respect.

### WARNING

**Urethane foam is flammable! Do not allow any flames, sparks, or other heat sources such as cigarettes or light bulbs to contact urethane foam. Urethane foam in contact with such heat sources could cause a serious, rapid fire, which could result in death, severe burns, or gas poisoning, as well as damage to the vehicle.**

### In Case of a Cab Fire

As quickly as possible, bring the vehicle to a safe stop, apply the parking brake, turn off the ignition, and get out of the vehicle.

## In an Emergency

---



06/09/2014

f602528

**Fig. 23.4, Tension Strap Installed to Hold Down the Cab**

# Index

---

| Subject                         | Page  |
|---------------------------------|-------|
| <b>A</b>                        |       |
| ABTS Seat                       | 6.6   |
| Armrest Adjustment              | 6.7   |
| Backrest Adjustment             | 6.7   |
| Cushion Extension Adjustment    | 6.6   |
| Isolator                        | 6.6   |
| Lumbar Adjustment               | 6.6   |
| Seat Height Adjustment          | 6.6   |
| Seat Tilt Control               | 6.7   |
| Shoulder Belt Height Control    | 6.7   |
| Track Adjustment                | 6.6   |
| Adjusting Headlight Aim         | 22.1  |
| Air Brake System                | 12.1  |
| Automatic Slack Adjusters       | 12.3  |
| Brake System Operation          | 12.1  |
| General Information             | 12.1  |
| Air Suspension Dump Valve       | 18.1  |
| Allison Automatic Transmissions | 14.13 |
| General Information, Allison    | 14.13 |
| Operation Tips, Allison         | 14.14 |

|                                |     |
|--------------------------------|-----|
| <b>B</b>                       |     |
| Back-of-Cab Access             | 2.4 |
| Climbing Down from Back-of-Cab | 2.5 |
| Climbing Up to Back-of-Cab     | 2.4 |
| Bostrom Seat                   | 6.4 |
| Back Cushion Tilt              | 6.4 |
| Bottom Cushion Tilt Adjustment | 6.4 |
| Damper Adjustment              | 6.5 |
| Fore-and-Aft Seat Adjustment   | 6.4 |
| Isolator                       | 6.4 |
| Lumbar Support                 | 6.5 |
| Weight and Height Adjustment   | 6.4 |

|                           |     |
|---------------------------|-----|
| <b>C</b>                  |     |
| Cab Amenities             | 8.1 |
| Center Dash               | 8.1 |
| Overhead Storage          | 8.1 |
| Cab Climate-Control Panel | 7.1 |
| Air Conditioning          | 7.2 |
| Air Selection             | 7.1 |
| Bunk Override             | 7.3 |
| Fan Control               | 7.1 |
| Recirculation             | 7.2 |

|   |      |
|---|------|
| Temperature Control                           | 7.2  |
| Cab Door Locks and Handles                    | 2.1  |
| Cab Washing and Polishing                     | 21.1 |
| Cab-to-Sleeper Access                         | 2.3  |
| Canadian Motor Vehicle Safety Standard Labels | 1.1  |
| Care of Chrome Parts                          | 21.1 |
| Care of Exterior Lights                       | 21.1 |
| Care of Fiberglass Parts                      | 21.1 |
| Checking Headlight Aim                        | 22.1 |
| Checklists                                    | 19.1 |
| Daily Pretrip Inspection Checklists           | 19.1 |
| Monthly Post-trip Inspection Checklists       | 19.2 |
| Weekly Post-trip Inspection Checklist         | 19.2 |
| Clutch  | 13.5 |
| Clutch Maintenance                            | 13.7 |
| Clutch Operation                              | 13.5 |
| General Information                           | 13.5 |
| Component GWR Label                           | 1.1  |
| Component Information Label                   | 1.1  |
| Cruise Control                                | 10.2 |

|  |      |
|--|------|
| <b>D</b>   |      |
| Daily Pretrip Inspection and Maintenance                 | 20.1 |
| Cab Inspection   | 20.5 |
| Engine Compartment Inspection                            | 20.4 |
| Saddle Tank Areas Inspection                             | 20.3 |
| Suspension and Slack Adjuster Inspection                 | 20.1 |
| Wheel and Tire Inspection                                | 20.1 |
| Dashboard Care   | 21.1 |
| Dash-Mounted Brake Controls                              | 5.7  |
| Parking Brake Control Valve and Trailer Air Supply Valve | 5.7  |
| Trailer Brake Hand Control Valve Lever                   | 5.8  |
| Diesel Exhaust Fluid and Tank                            | 11.3 |
| DEF Tank   | 11.4 |
| DEF Warnings and Engine Limits                           | 11.5 |
| Diesel Exhaust Fluid                                     | 11.3 |
| Fuel/DEF Gauge   | 11.4 |
| Door Mounted Controls                                    | 5.2  |
| Air Horn   | 5.3  |

| Subject   | Page  | Subject  | Page |
|---|-------|--|------|
| Drive Axles with Differential Lock  | 15.1  | Low (L)  | 14.3 |
| Drive Axles with Main Differential Lock                                   | 15.1  | Manual Mode (MAN)                              | 14.2 |
| Single Drive Axles with Traction Equalizer                                | 15.2  | Power Down                                     | 14.2 |
| Tandem Drive Axles with Interaxle Differential                            | 15.1  | Power Up                                       | 14.1 |
| Driver Message Center   | 4.11  | Reverse (R)                                    | 14.2 |
| ICU4  | 4.11  | Shuttle Shifting                               | 14.4 |
| ICU4Me  | 4.22  | Skip Shifting                                  | 14.4 |
| ICU4M   | 4.13  | Emergency Kit, Optional                        | 23.1 |
| <b>E</b>  |       |  |      |
| Eaton Fuller 10-Speed Range-Shift Transmissions                           | 13.4  | Emergency Starting With Jumper Cables          | 23.1 |
| General Information, Eaton Fuller Range-Shift                             | 13.4  | Emissions Labels                               | 1.2  |
| Operation Tips, Eaton Fuller Range-Shift                                  | 13.4  | Aftertreatment System Indicators Label         | 1.2  |
| Eaton Fuller 13-Speed and 18-Speed Splitter and Range-Shift Transmissions | 13.1  | Certified Clean Idle Label                     | 1.4  |
| General Information, Eaton Fuller Splitter and Range-Shift                | 13.1  | EPA Noise Emission Control Label               | 1.3  |
| Operation Tips, Eaton Fuller Splitter and Range-Shift                     | 13.1  | Vehicle Emission Control Information Label     | 1.4  |
| Eaton Fuller AutoShift Automated Transmissions                            | 14.10 | Engine Brakes                                  | 10.3 |
| General Information, AutoShift  | 14.10 | Engine Brake Operation                         | 10.4 |
| Operation, AutoShift with SmartShift                                      | 14.11 | Engine Idle Limiting                           | 10.1 |
| Eaton Fuller UltraShift DM Automated Transmissions                        | 14.5  | California Engine Idle Limiting                | 10.2 |
| General Information, UltraShift DM  | 14.5  | Idle Shutdown Timer                            | 10.1 |
| Operation, UltraShift DM  | 14.5  | Engine Operation                               | 9.2  |
| Ultrashift Diagnostics  | 14.9  | Cold-Weather Operation                         | 9.3  |
| Eaton Fuller UltraShift PLUS Automated Transmissions                      | 14.1  | Engine Break-In                                | 9.2  |
| Auto Neutral  | 14.4  | Normal Operation                               | 9.2  |
| Auto Start Gear Selection and Override                                    | 14.4  | Safety and Environmental Considerations        | 9.2  |
| Automatic Mode (AUTO)   | 14.2  | Engine Protection—Warning and Shutdown         | 10.1 |
| Automatic Traction Control  | 14.4  | Engine Shutdown                                | 9.4  |
| Clutch Abuse Protection   | 14.3  | Engine Starting                                | 9.1  |
| Coasting  | 14.5  | Cold-Weather Starting                          | 9.2  |
| Creep Mode  | 14.3  | Starting After Extended Shutdown               | 9.2  |
| Engine Overspeed Protection   | 14.4  | EPA-Regulated Emissions Aftertreatment Systems | 11.1 |
| Hill Start Aid  | 14.4  | ATS Warning Lamps                              | 11.3 |
| Load-Based Shifting   | 14.5  | DPF Maintenance                                | 11.3 |
|   |       | Regeneration                                   | 11.1 |
|   |       | EzyRider® Seat                                 | 6.2  |
|   |       | Armrest Angle (optional armrests)              | 6.3  |
|   |       | Back Cushion Tilt                              | 6.2  |
|   |       | Bottom Cushion Angle                           | 6.3  |
|   |       | Fore-and-Aft Slide Adjustment                  | 6.3  |
|   |       | Height Adjustment                              | 6.3  |
|   |       | Isolator                                       | 6.3  |
|   |       | Lumbar Support                                 | 6.3  |

# Index

---

| Subject   | Page |
|---|------|
| <b>F</b>  |      |
| Federal Motor Vehicle Safety Standard Labels            | 1.1  |
| Fifth Wheel Coupling                                    | 17.1 |
| Fontaine and Holland Fifth Wheels Coupling              | 17.1 |
| Jost Fifth Wheel Coupling                               | 17.3 |
| Fifth Wheel Slide                                       | 17.7 |
| Air Slide Operation                                     | 17.9 |
| Manual Slide Operation                                  | 17.7 |
| Fifth Wheel Uncoupling                                  | 17.4 |
| Air-Actuated Uncoupling                                 | 17.5 |
| Manual Uncoupling                                       | 17.4 |
| Fifth Wheels, General Information                       | 17.1 |
| Air-Suspension Dump Valve                               | 17.1 |
| Fifth Wheel Lubrication                                 | 17.1 |
| Fire Extinguisher                                       | 23.1 |
| Fire in the Cab   | 23.4 |
| In Case of a Cab Fire                                   | 23.4 |
| Fluids Added  | 19.2 |
| Freightliner High-Back Seat                             | 6.2  |
| Backrest Tilt   | 6.2  |
| Bottom Cushion Extension                                | 6.2  |
| Fore/Aft Isolator                                       | 6.2  |
| Fore/Aft Seat Slide                                     | 6.2  |
| Front Cushion Height                                    | 6.2  |
| Heater  | 6.2  |
| Height Adjustment                                       | 6.2  |
| Lumbar Support  | 6.2  |
| Rear Cushion Height                                     | 6.2  |
| Shock Absorber  | 6.2  |
| Freightliner SmartShift Shift Control                   | 14.1 |
| General Information, SmartShift                         | 14.1 |
| <b>G</b>  |      |
| Grab Handles and Access Steps                           | 2.1  |
| Entering the Driver Side                                | 2.1  |
| Entering the Passenger Side                             | 2.2  |
| Exiting the Driver Side                                 | 2.2  |
| Exiting the Passenger Side                              | 2.2  |
| Greenhouse Gas Emissions and Fuel Consumption Standards | 11.1 |
| Guarded Switches  | 5.6  |
| Air Suspension Dump Control                             | 5.6  |

| Subject                                      | Page  |
|--|-------|
| Controlled Traction Differential Control     | 5.7   |
| Fifth Wheel Air Slide Control                | 5.7   |
| Interaxle Differential Lockout Control       | 5.7   |
| <b>H</b>                                     |       |
| Hazard Warning Lights                        | 23.1  |
| Holland Trailer Coupling                     | 18.1  |
| General Information                          | 18.1  |
| Operation                                    | 18.1  |
| Hood Opening and Closing                     | 2.5   |
| To Return the Hood                           | 2.5   |
| To Tilt the Hood                             | 2.5   |
| <b>I</b>                                     |       |
| Instrumentation Control Units                | 4.1   |
| Audible Alerts                               | 4.1   |
| Ignition Sequence                            | 4.1   |
| Interior Lighting                            | 8.1   |
| Baggage Compartment Lights                   | 8.2   |
| Bunk Reading Lights                          | 8.1   |
| Dome Lights                                  | 8.1   |
| Overhead Light                               | 8.1   |
| <b>L</b>                                     |       |
| Lower Right-Hand Dash Panel Switches         | 5.3   |
| Foot Well Courtesy Lamp Switch               | 5.4   |
| Mirror Heat Switch                           | 5.4   |
| Panel Lamps Control Switch                   | 5.3   |
| <b>M</b>                                     |       |
| Main Dash Switches                           | 5.4   |
| ATC Switch                                   | 5.4   |
| Engine Fan Switch                            | 5.4   |
| Marker Lights Interrupt Switch               | 5.4   |
| Regen Switch                                 | 5.4   |
| Road Lamp Switch                             | 5.4   |
| Trailer Auxiliary Switch                     | 5.4   |
| Meritor WABCO® Antilock Braking System (ABS) | 12.3  |
| Trailer ABS Lamp Operation                   | 12.4  |
| Monthly Post-Trip Inspection and Maintenance | 20.10 |
| Brake Component Inspection                   | 20.10 |

| Subject   | Page  | Subject                                     | Page |
|---|-------|---|------|
| Engine Compartment Inspection and Adjustments             | 20.12 | Roll Stability Control                      | 4.27 |
| Saddle Tank Areas Inspection                              | 20.11 | Trip/Leg Totals                             | 4.27 |
| <b>N</b>  |       | <b>S</b>                                    |      |
| National 2000 Series Seat                                 | 6.5   | Sears Atlas Seat                            | 6.5  |
| Back Cushion Tilt   | 6.5   | Armrest Adjustment                          | 6.5  |
| Bottom Cushion Front Height                               | 6.6   | Backrest Adjustment                         | 6.5  |
| Fore-and-Aft Seat Adjustment                              | 6.6   | Fore-and-Aft Slide Adjustment               | 6.5  |
| Height Adjustment   | 6.6   | Isolation Adjustment                        | 6.5  |
| Isolator  | 6.6   | Lumbar Adjustment                           | 6.5  |
| Lumbar Support  | 6.6   | Seat Tilt/Extension Adjustment              | 6.5  |
| Rear Cushion Adjustment                                   | 6.6   | Suspension (Ride) Adjustment                | 6.5  |
| <b>O</b>  |       | Seat Belts and Tether Belts                 | 6.7  |
| Optimized Idle®   | 10.5  | General Information                         | 6.7  |
| Optional Instruments                                      | 4.10  | Seat Belt Inspection                        | 6.8  |
| Air Restriction Gauge                                     | 4.10  | Seat Belt Operation                         | 6.8  |
| Brake Application Air Pressure Gauge                      | 4.11  | Seats, General Information                  | 6.1  |
| Drive Axle Oil Temperature Gauges                         | 4.11  | Sleeper Climate-Control Panel               | 7.3  |
| Engine Oil Temperature Gauge                              | 4.11  | Accessory Heaters                           | 7.3  |
| Transmission Fluid Temperature Gauge                      | 4.11  | Fan Control                                 | 7.3  |
| Turbocharger Boost Pressure Gauge                         | 4.11  | Temperature Control                         | 7.3  |
| Overhead Instrument Panel                                 | 4.27  | Sleeper Exit Door                           | 2.3  |
| <b>P</b>  |       | Sleeper Luggage Door                        | 2.4  |
| Parked HVAC   | 7.4   | Standard Instruments                        | 4.8  |
| Parked-HVAC Controls                                      | 7.4   | Coolant Temperature Gauge                   | 4.8  |
| Periodic Inspections and Maintenance, General Information | 19.1  | Engine Oil Pressure Gauge                   | 4.9  |
| Power Steering System                                     | 16.1  | Fuel/Diesel Exhaust Fluid (DEF) Gauge       | 4.9  |
| Power Takeoff (PTO) Governor                              | 10.5  | Primary and Secondary Air Pressure Gauges   | 4.9  |
| Preliminary Checks  | 22.1  | Speedometer                                 | 4.10 |
| Premier Trailer Couplings                                 | 18.2  | Tachometer                                  | 4.10 |
| General Information                                       | 18.2  | Voltmeter                                   | 4.10 |
| Operation   | 18.2  | Steering Column and Left-Hand Dash Controls | 5.1  |
| <b>R</b>  |       | Adjustable Steering Column                  | 5.2  |
| Roll Stability System                                     | 4.25  | Electric Horn                               | 5.2  |
| Hard-Braking Advisor                                      | 4.27  | Hazard Warning Light Switch Tab             | 5.2  |
| Roll Stability Advisor                                    | 4.26  | Headlight Dimmer                            | 5.2  |
|   |       | Headlight Switch                            | 5.1  |
|   |       | Ignition and Key Switch                     | 5.1  |
|   |       | Turn Signal Lever                           | 5.2  |
|   |       | Utility Light Switch                        | 5.2  |
|   |       | Steering Wheel Air Bag                      | 6.11 |
|   |       | Inspection and Service                      | 6.11 |
|   |       | Operation                                   | 6.11 |

# Index

---

| Subject  | Page |
|--|------|
| <b>T</b>                                       |      |
| Towing   | 23.2 |
| Front Towing Hookup                            | 23.2 |
| Rear Towing Hookup                             | 23.3 |
| <b>V</b>                                       |      |
| Vehicle Power Supply                           | 3.1  |
| Battery Access                                 | 3.2  |
| Load Disconnect Switch                         | 3.1  |
| Low Voltage Disconnect,<br>Optional            | 3.1  |
| Power Distribution                             | 3.1  |
| Velour Upholstery Cleaning                     | 21.3 |
| Chewing Gum or Wax                             | 21.3 |
| Grease and Oil-Based Stains                    | 21.3 |
| Mildew   | 21.3 |
| Sugar and Water-Based<br>Stains                | 21.3 |
| Vinyl Upholstery Cleaning                      | 21.2 |
| Ball Point Ink                                 | 21.2 |
| Chewing Gum                                    | 21.2 |
| Miscellaneous                                  | 21.2 |
| Nail Polish and Nail Polish<br>Remover         | 21.2 |
| Ordinary Dirt                                  | 21.2 |
| Paint, Shoe Heel Marks                         | 21.2 |
| Shoe Polish                                    | 21.2 |
| Sulfide Stains                                 | 21.2 |
| Tars, Asphalts, and Creosote                   | 21.2 |
| <b>W</b>                                       |      |
| Warning and Indicator Lights                   | 4.1  |
| Engine Protection System                       | 4.7  |
| Weekly Post-Trip Inspection<br>and Maintenance | 20.8 |
| Engine Compartment<br>Inspection               | 20.8 |
| Windshield Wiper/Washer                        | 5.6  |
| Dash Controls                                  | 5.6  |
| Windshield Washer Fluid<br>Reservoir           | 5.6  |