

Engineering Release Notice (ERN)	Location	Change Description	A = Added D = Deleted	W = Was	Document Release Status RELEASED
D-16585-05		SEE DCN			Date Modification Count

WIRING DIAGRAM INDEX, 12V

NAME	DESCRIPTION	Page	NAME	DESCRIPTION	Page
AA-O	NYC POWER DISTRIBUTION	2	GA-O	NYC LIGHTING CLN POWER FLASHER	10
AC-O	NYC IGN DISCONNECT	3	GD-O	NYC LIGHTING PLOW LIGHTS	11
BC-O	NYC CUSTOMER INTERFACE CA V1	4	NA-O	NYC SPARE CONNECTORS & FEEDS	12
BH-O	NYC BBM V3	5	NB-O	NYC SPARES FEEDS V1	13
BM-O	NYC SINGLE BIN BB	6	NE-O	NYC SINGLE BIN BB	14
BN-O	NYC SINGLE DUAL BI BB	7	NF-O	NYC SINGLE DUAL BIN ELECTRIC FUEL PRIMER PUMP & VENT FANS	15
CK-O	NYC DPF ALERT	8	XA-O	NYC DIANOSTICS CONNECTOR	16
FC-O	NYC SINGLE DUAL BIN BB	9			

<p>The copying, distribution and utilization of this document as well as the communication of its contents to others without expressed authorization is prohibited. Offenders will be held liable for payment of damages. All rights reserved in the event of the grant of a patent, utility model or ornamental design registration.</p>	Document Title WIRING DIAGRAM			
	12V - TYPE OL L1EH1			
	NYC - DEPT OF SANITATION - SINGLE BIN			
	Document Type TECHNICAL REGULATION			
<p>MACK</p> <p>Mack Trucks, Inc.</p>	Owner Domain: Document Prefix			
	Document No	Issue Index	Volume No	Page No
	22617224	02	01	1(16)

EDM-W 2000-04-01

NYC_POWER_DISTRIBUTION

WIRING DIAGRAM: AA-0

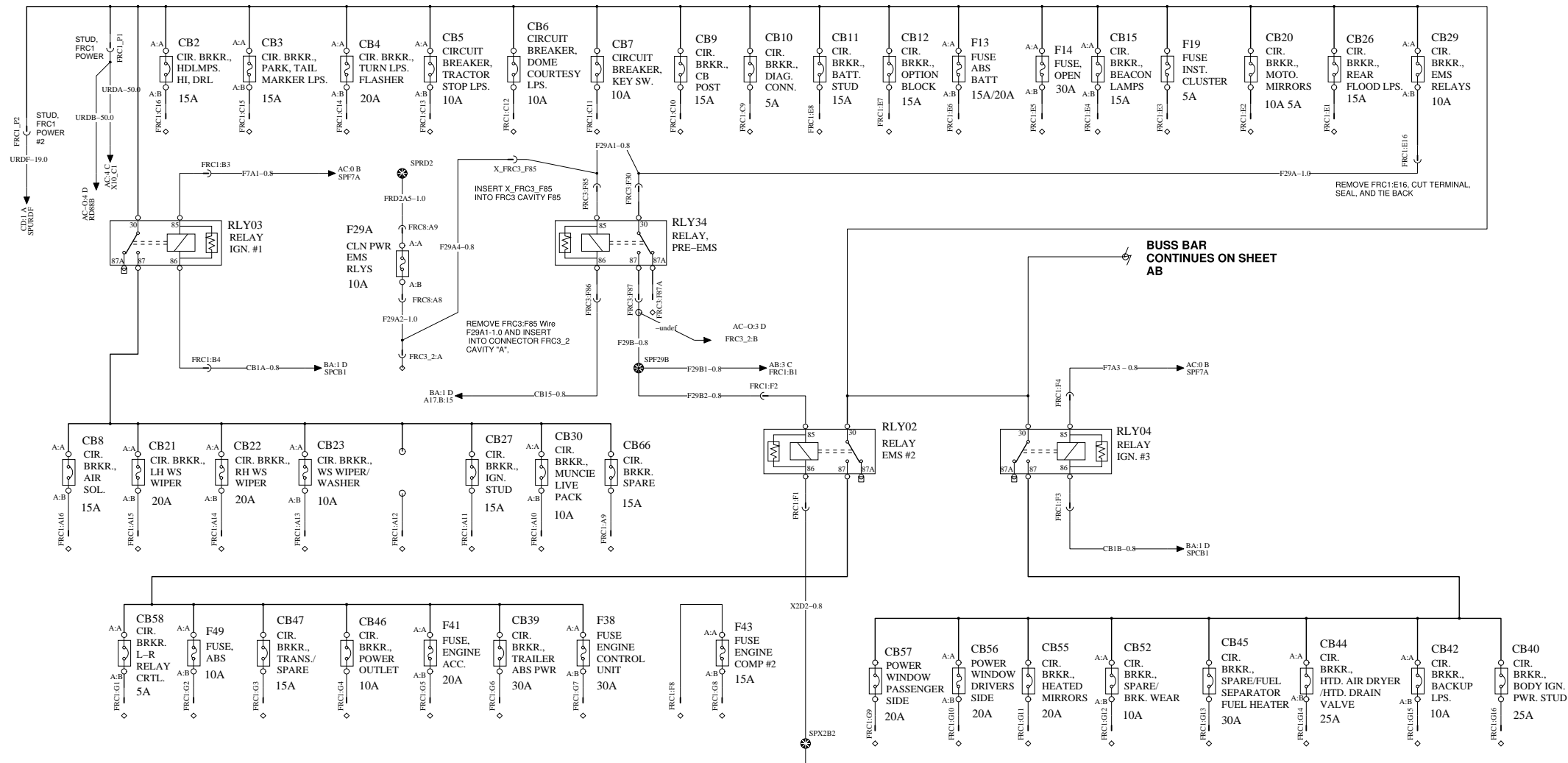
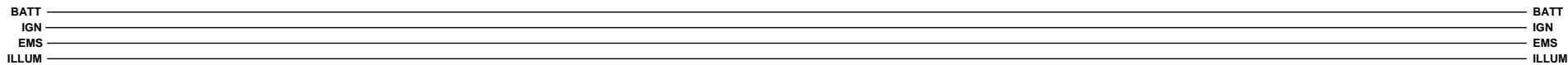

BUSS BAR CONTINUES ON SHEET AB

MACK

Mack Trucks Inc.

Document title
WIRING DIAGRAM

Drawing No.
22617224

Revision
02

Page
2 (16)

https://www.truckmanuals.net/

NYC_IGN_DISCONNECT

WIRING DIAGRAM: AC-O

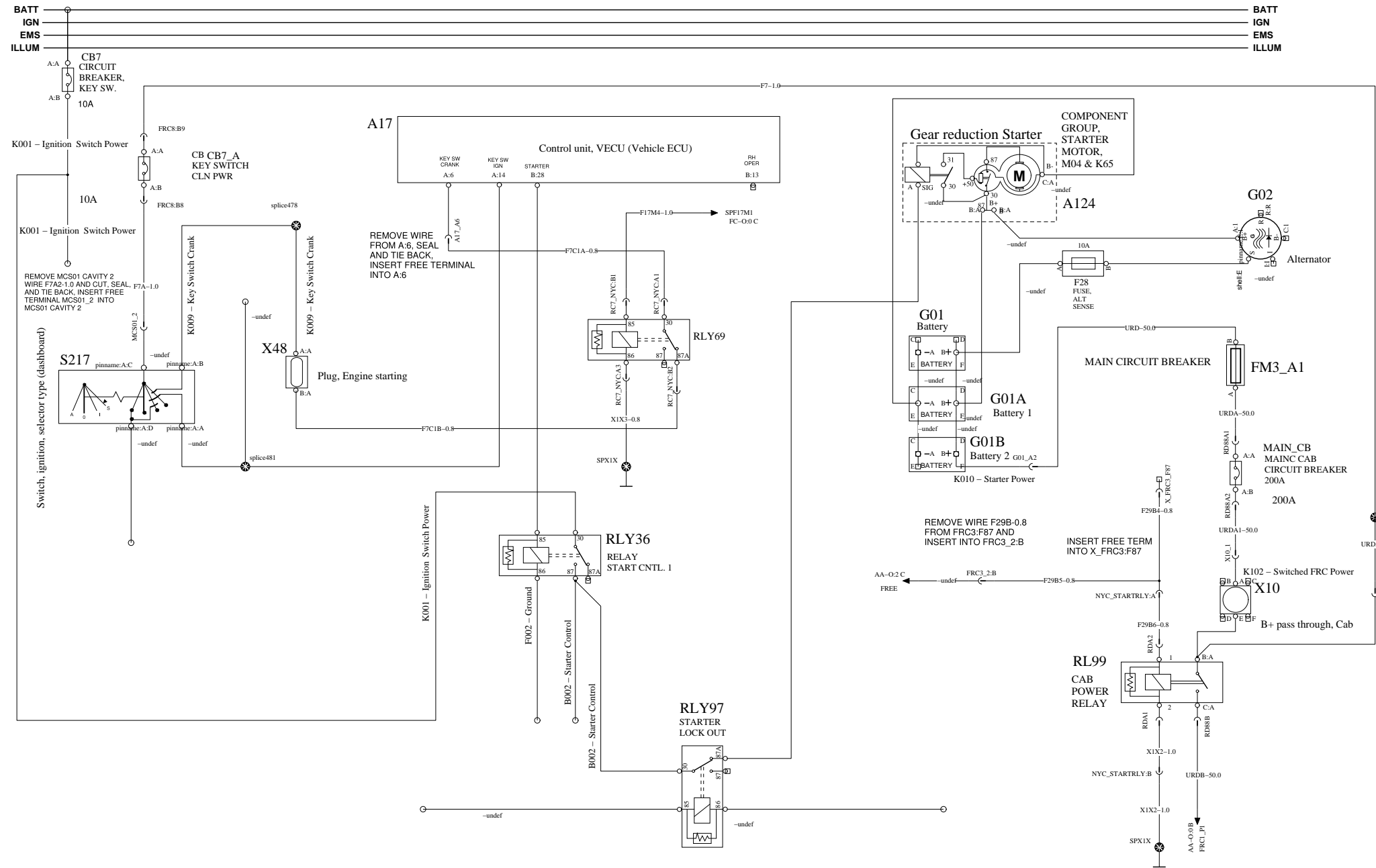

MACK

Mack Trucks Inc.

Document title
 WIRING DIAGRAM - TYPE OL L1EH1 - NYC DS

Document type
<https://www.truckmanuals.net/>

Drawing No.
 22617224

Revision
 02

Page
 3 (16)

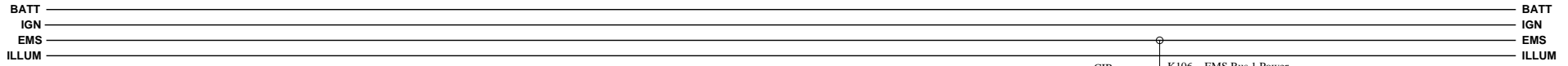

X21A
Socket, Body builder connector

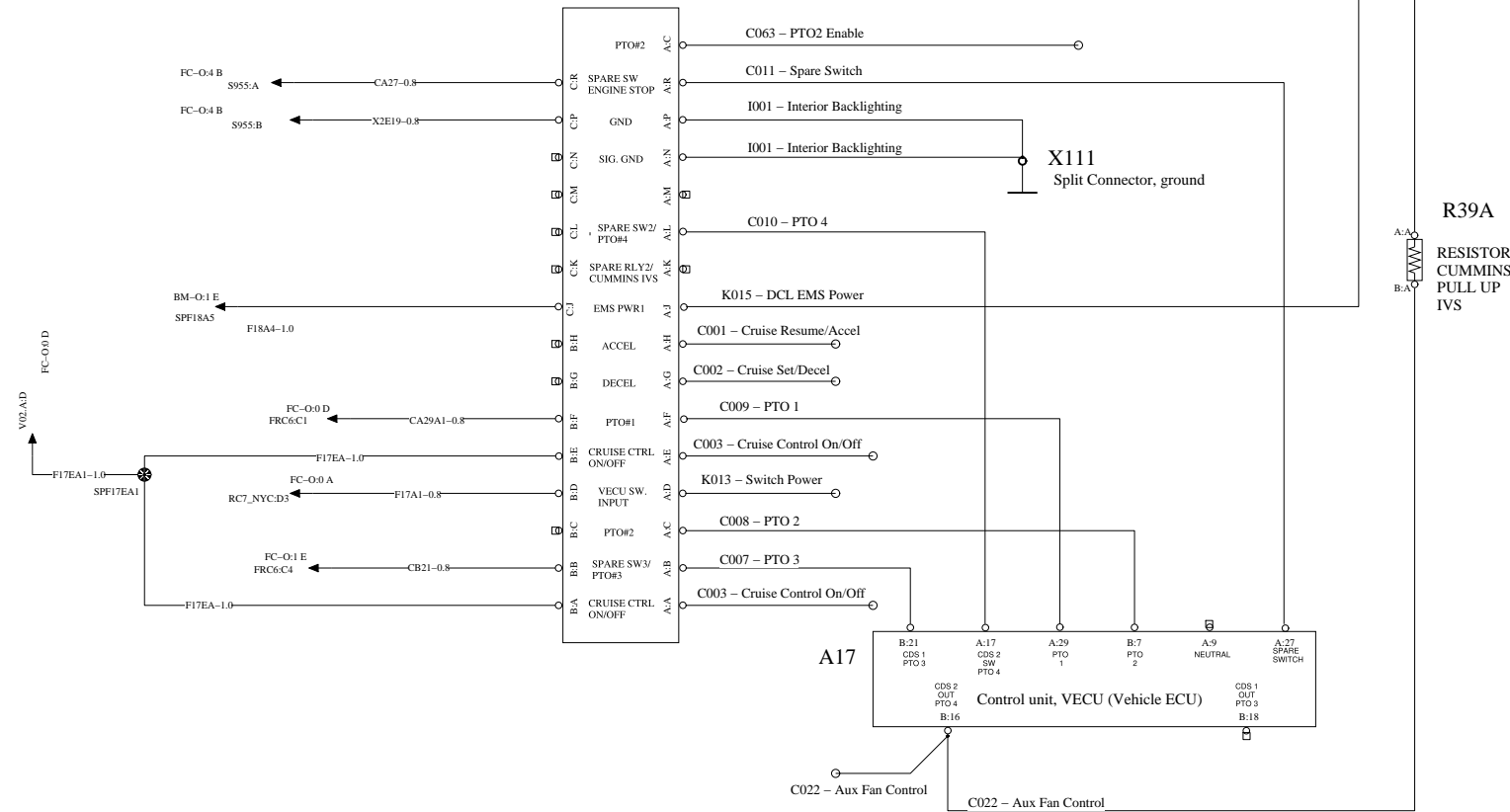

NYC_BBM_V3

WIRING DIAGRAM: BH-O

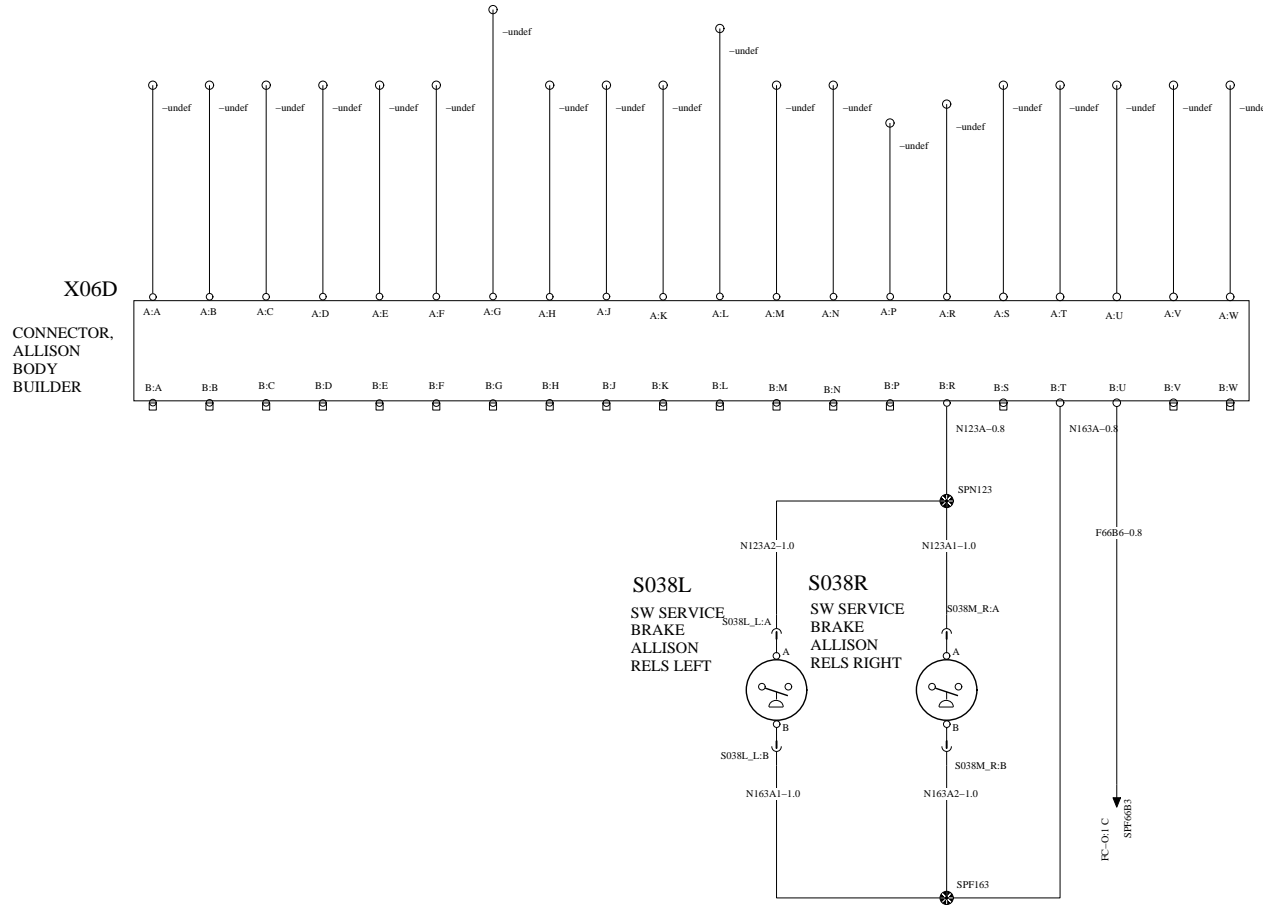
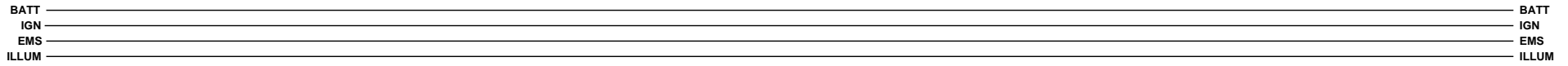

MACK

Mack Trucks Inc.

Document title
WIRING DIAGRAM - TYPE OL L1EH1 - NYC DS

Document type

Drawing No.

22617224

Revision

02

Page

5 (16)

<https://www.truckmanuals.net/>

NYC_SINGLE_BIN_BB

WIRING DIAGRAM: BM-O

BATT
IGN
EMS
ILLUM

BATT
IGN
EMS
ILLUM

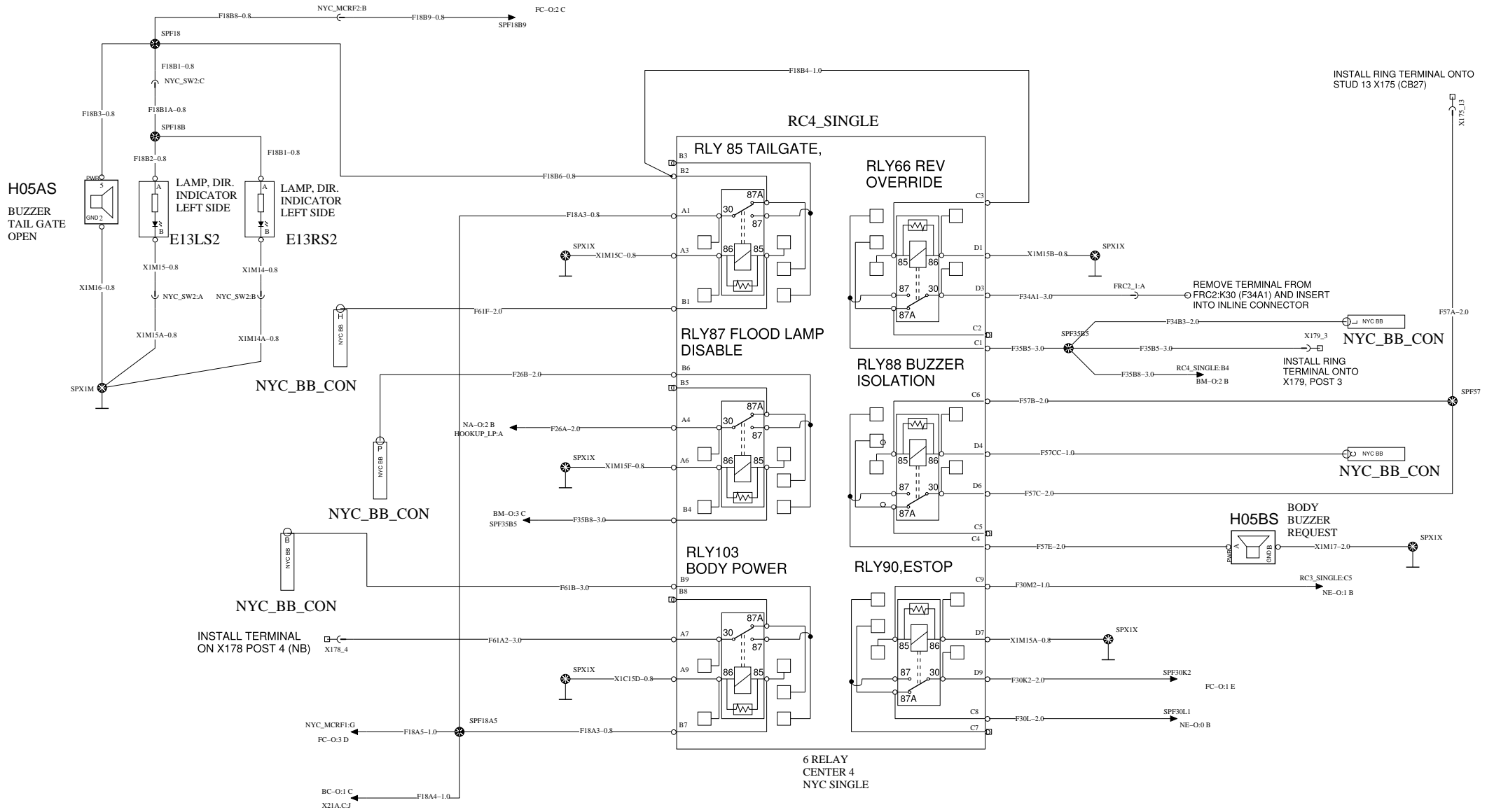

MACK

Mack Trucks Inc.

Document title
WIRING DIAGRAM - TYPE OL L1EH1 - NYC DS

Document type
<https://www.truckmanuals.net/>

Drawing No.
22617224

Revision
02

Page
6 (16)

NYC_SINGLE_DUAL_BIN_BB

WIRING DIAGRAM: BN-O

BATT
IGN
EMS
ILLUM

BATT
IGN
EMS
ILLUM

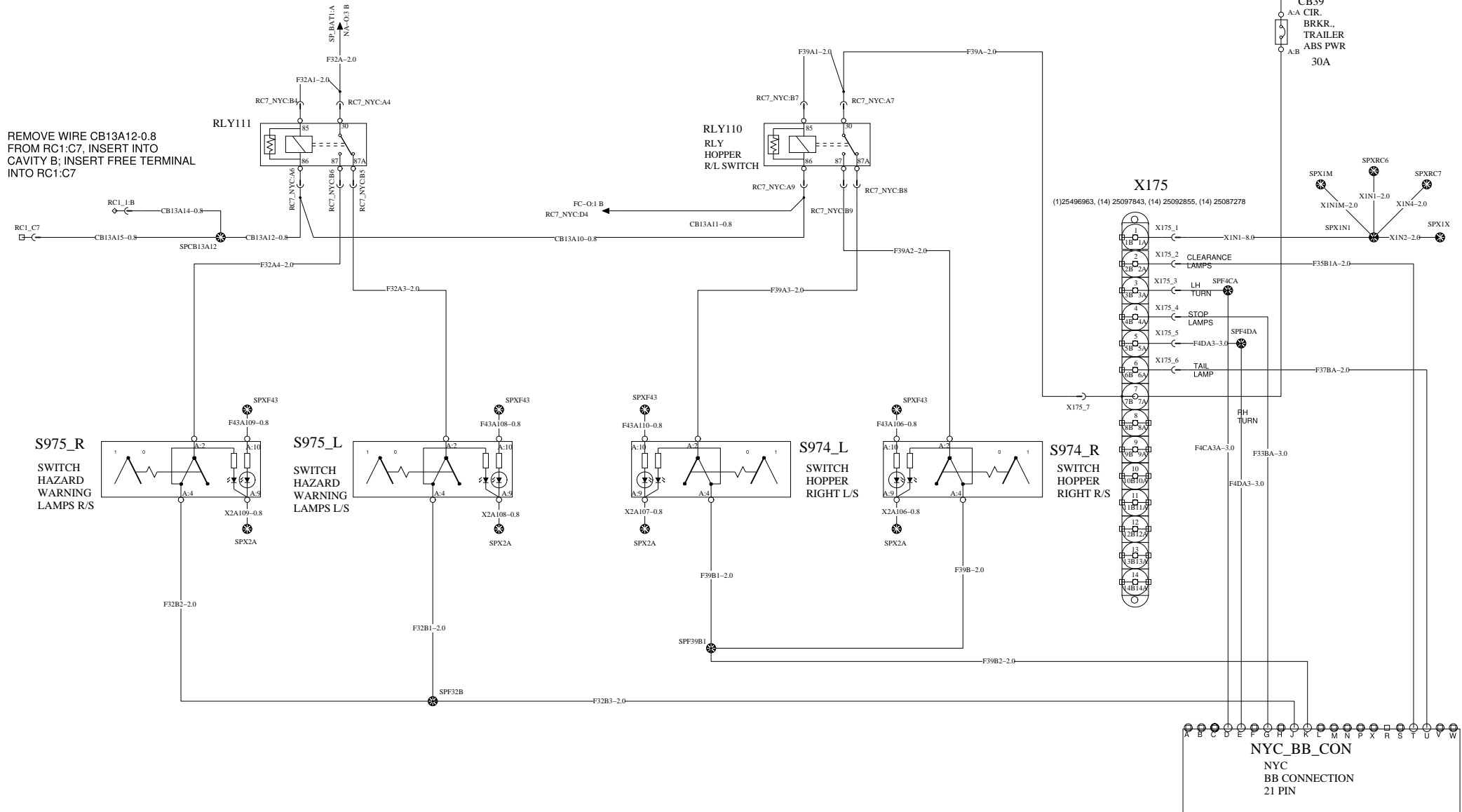

REMOVE WIRE CB13A12-0.8 FROM RC1:C7, INSERT INTO CAVITY B; INSERT FREE TERMINAL INTO RC1:C7

MACK

Mack Trucks Inc.

Document title
WIRING DIAGRAM - TYPE OL L1EH1 - NYC DS

Drawing No.

22617224

Revision

02

Page

7 (16)

Document type
<https://www.truckmanuals.net/>

NYC_BB_CON
NYC
BB CONNECTION
21 PIN

NYC_DPF_ALERT

WIRING DIAGRAM: CK-O

BATT
IGN
EMS
ILLUM

F64
FUSE,
DPF,
IGN
10A 15A 5A

FRC1:A3
INSERT FREE TERMINAL INTO LOCATION

F64A9-0.8

H06
BUZZER
CAB
DPF

X2E7-0.8

SPXE6

V05
Diode

V04
Diode

DPF_IND
CONTROL
UNIT
DPF ALERT
CAN I/O
INTERFACE

S111
DPF
REGEN
SWITCH

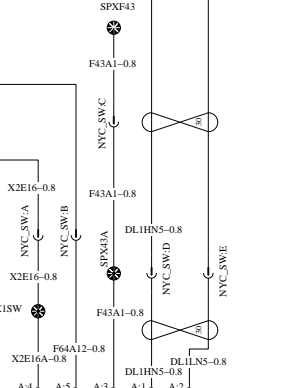
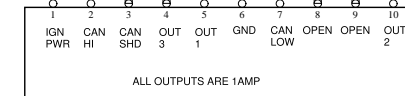
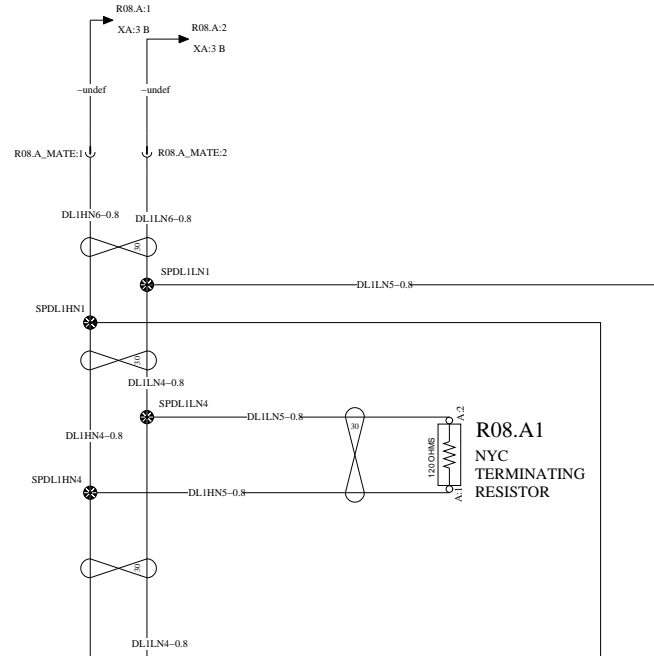

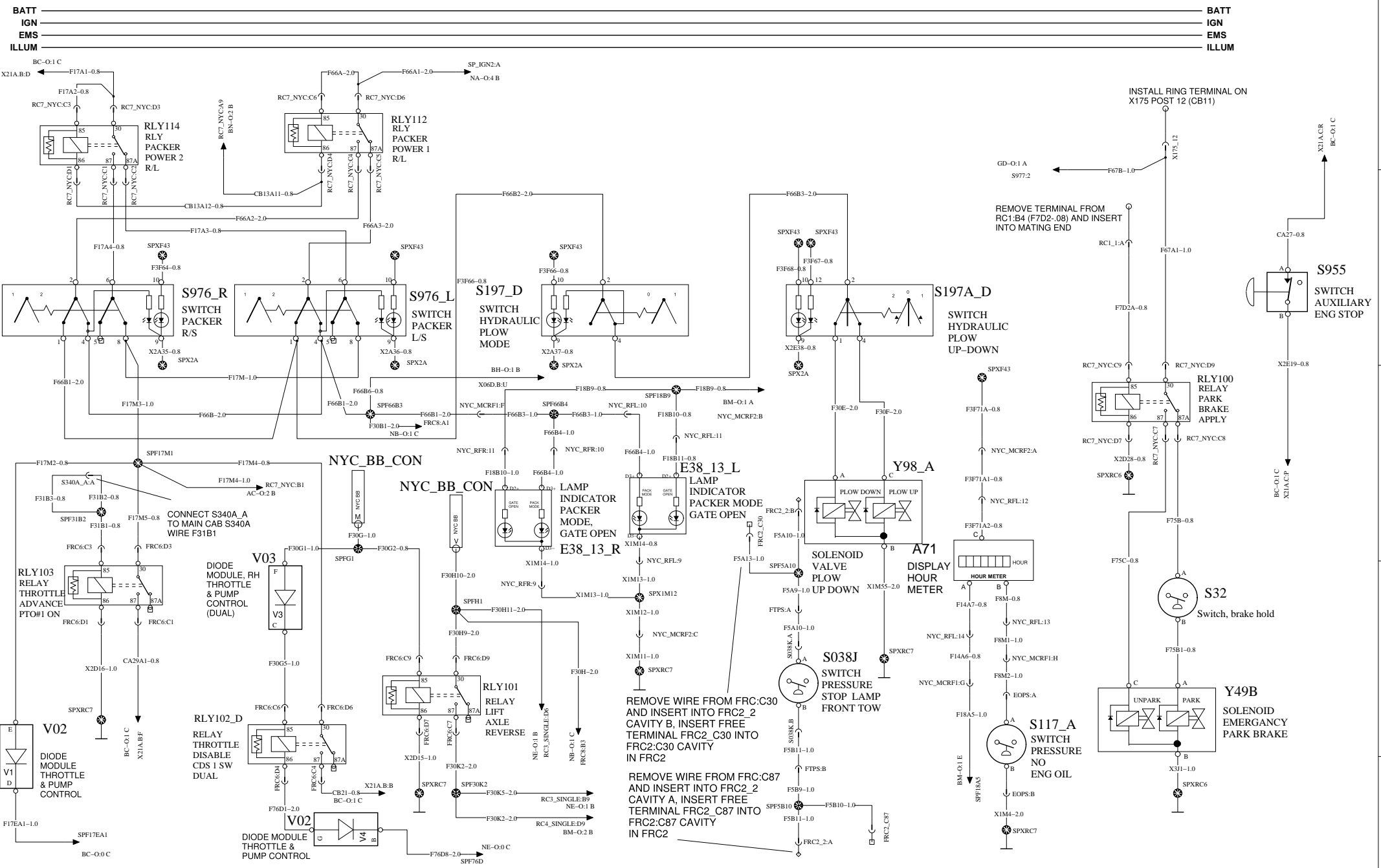

MACK

Mack Trucks Inc.

Document title
WIRING DIAGRAM - TYPE OL L1EH1 - NYC DS

Document type
<https://www.truckmanuals.net/>

Drawing No.
22617224

Revision
02

Page
9 (16)

BATT _____ BATT
 IGN _____ IGN
 EMS _____ EMS
 ILLUM _____ ILLUM

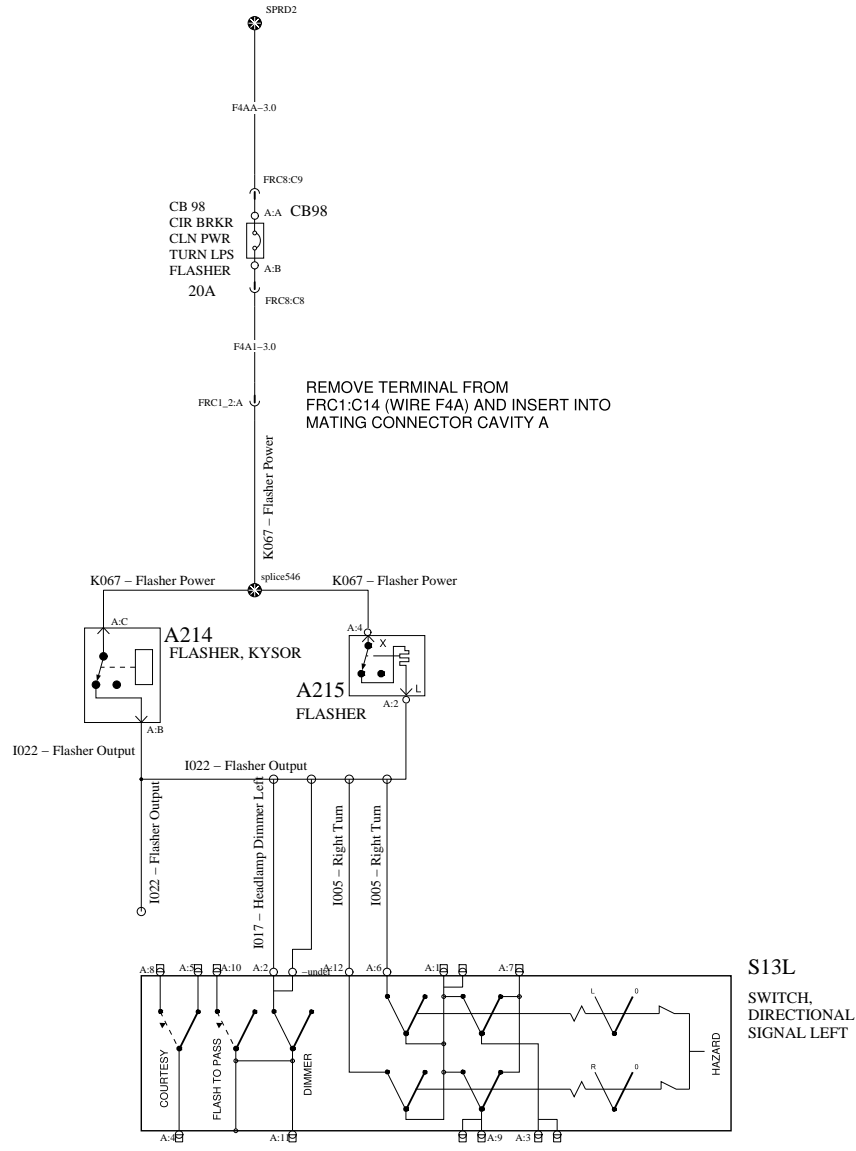

NYC_LIGHTING_PLOW_LIGHTS

WIRING DIAGRAM: GD-O

BATT	_____	BATT
IGN	_____	IGN
EMS	_____	EMS
ILLUM	_____	ILLUM

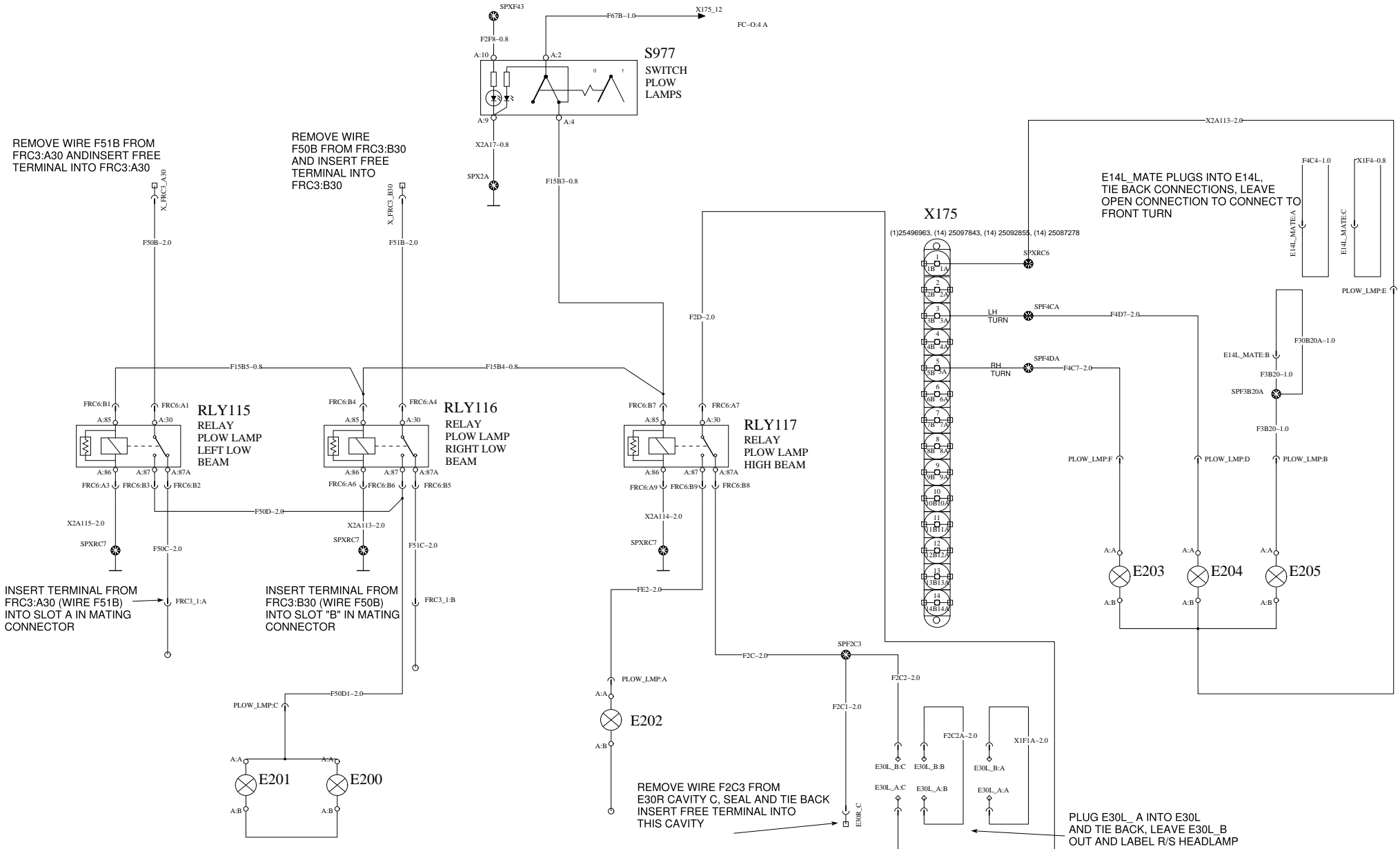

REMOVE WIRE F51B FROM FRC3:A30 AND INSERT FREE TERMINAL INTO FRC3:A30

REMOVE WIRE F50B FROM FRC3:B30 AND INSERT FREE TERMINAL INTO FRC3:B30

INSERT TERMINAL FROM FRC3:A30 (WIRE F51B) INTO SLOT A IN MATING CONNECTOR

INSERT TERMINAL FROM FRC3:B30 (WIRE F50B) INTO SLOT "B" IN MATING CONNECTOR

REMOVE WIRE F2C3 FROM E30R CAVITY C, SEAL AND TIE BACK INSERT FREE TERMINAL INTO THIS CAVITY

E14L_MATE PLUGS INTO E14L, TIE BACK CONNECTIONS, LEAVE OPEN CONNECTION TO CONNECT TO FRONT TURN

PLUG E30L_A INTO E30L AND TIE BACK, LEAVE E30L_B OUT AND LABEL R/S HEADLAMP

MACK

Mack Trucks Inc.

Document title
WIRING DIAGRAM - TYPE OL L1EH1 - NYC DS

Document type

Drawing No.

22617224

Revision

02

Page

11 (16)

<https://www.truckmanuals.net/>

NYC_SPARE_CONNECTORS_&_FEEDS

WIRING DIAGRAM: NA-O

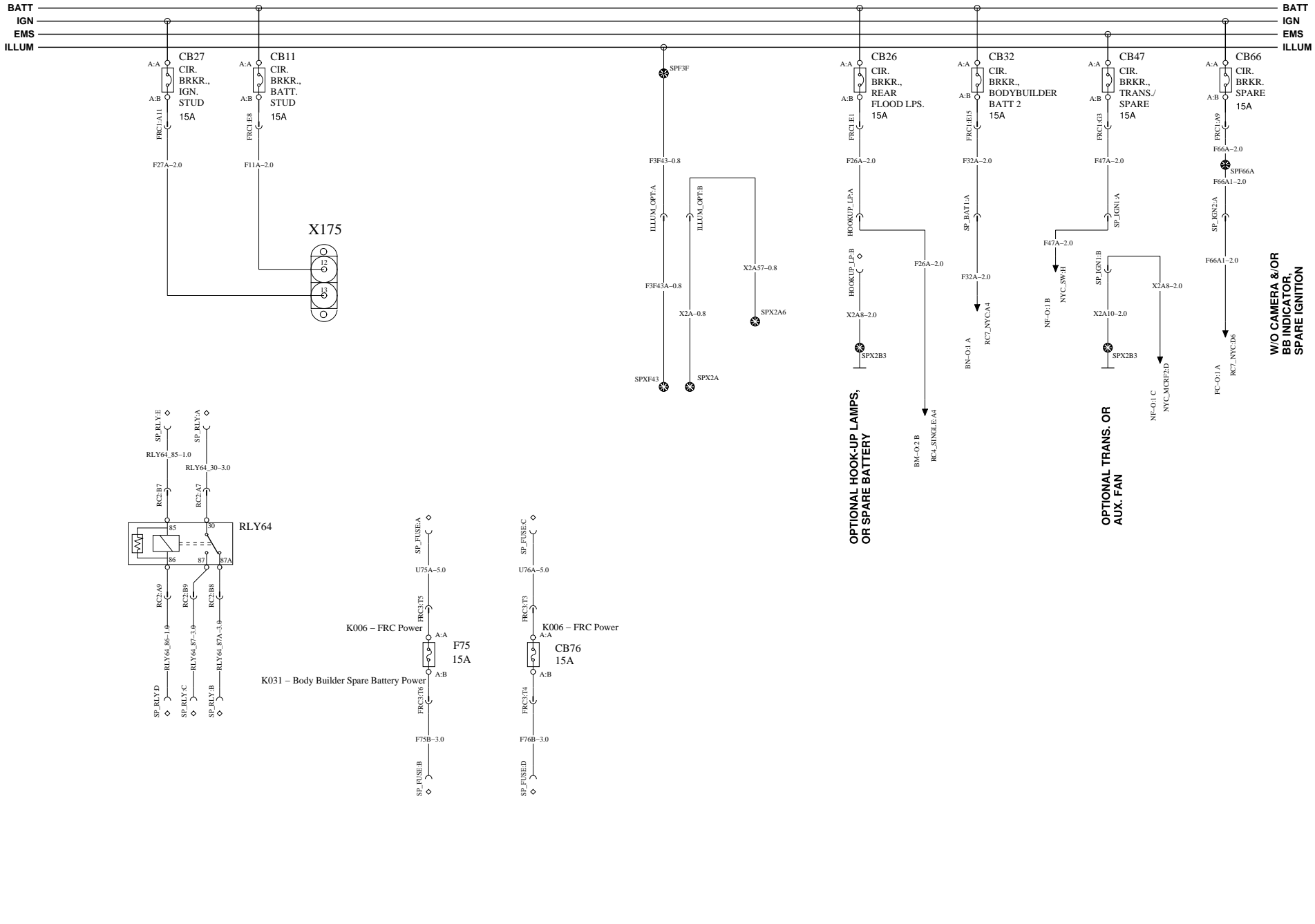

MACK

Mack Trucks Inc.

Document title
WIRING DIAGRAM - TYPE OL L1EH1 - NYC DS

Document type

Drawing No.

22617224

Revision

02

Page

12 (16)

<https://www.truckmanuals.net/>

BATT	_____	BATT
IGN	_____	IGN
EMS	_____	EMS
ILLUM	_____	ILLUM

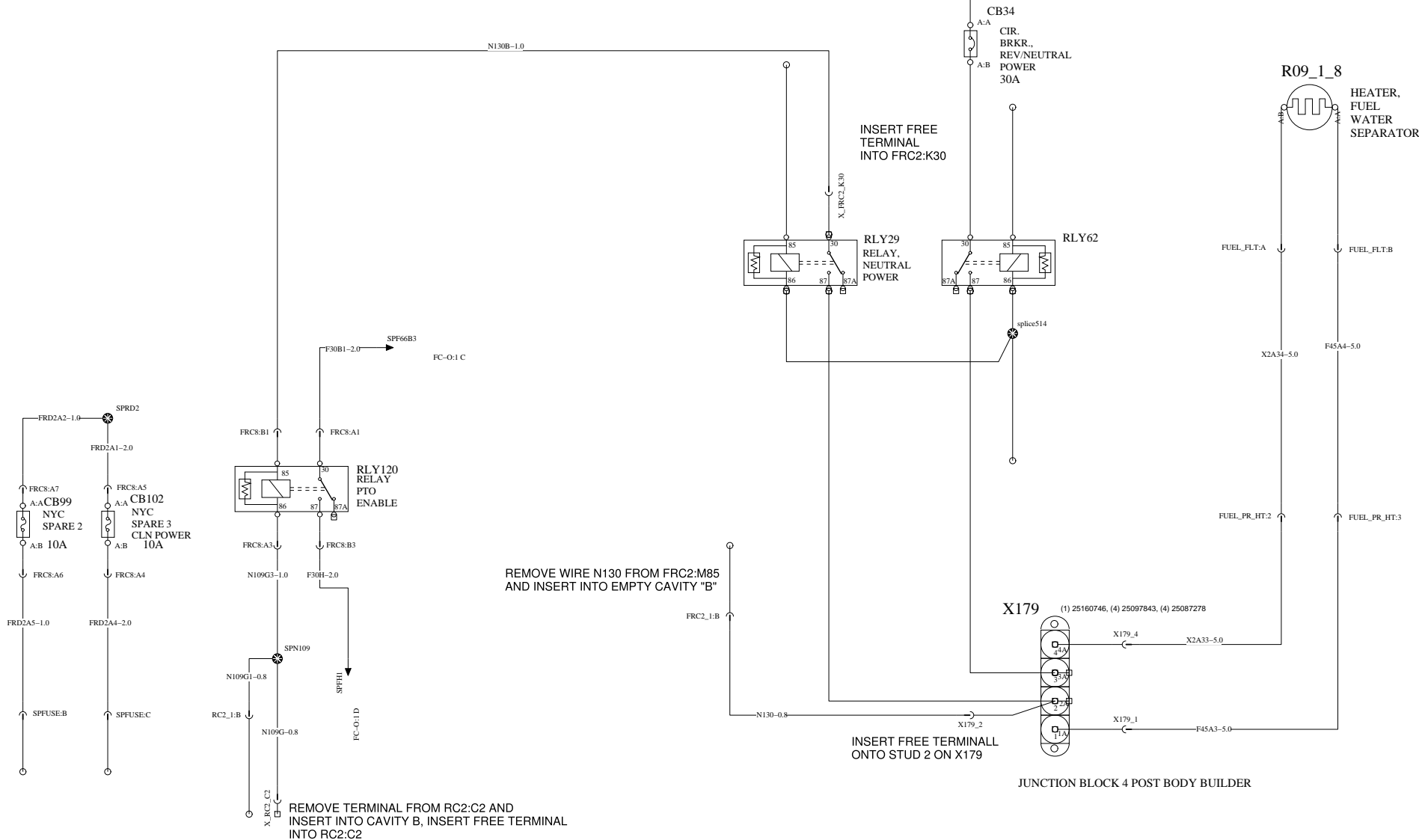

WIRING DIAGRAM: NE-O

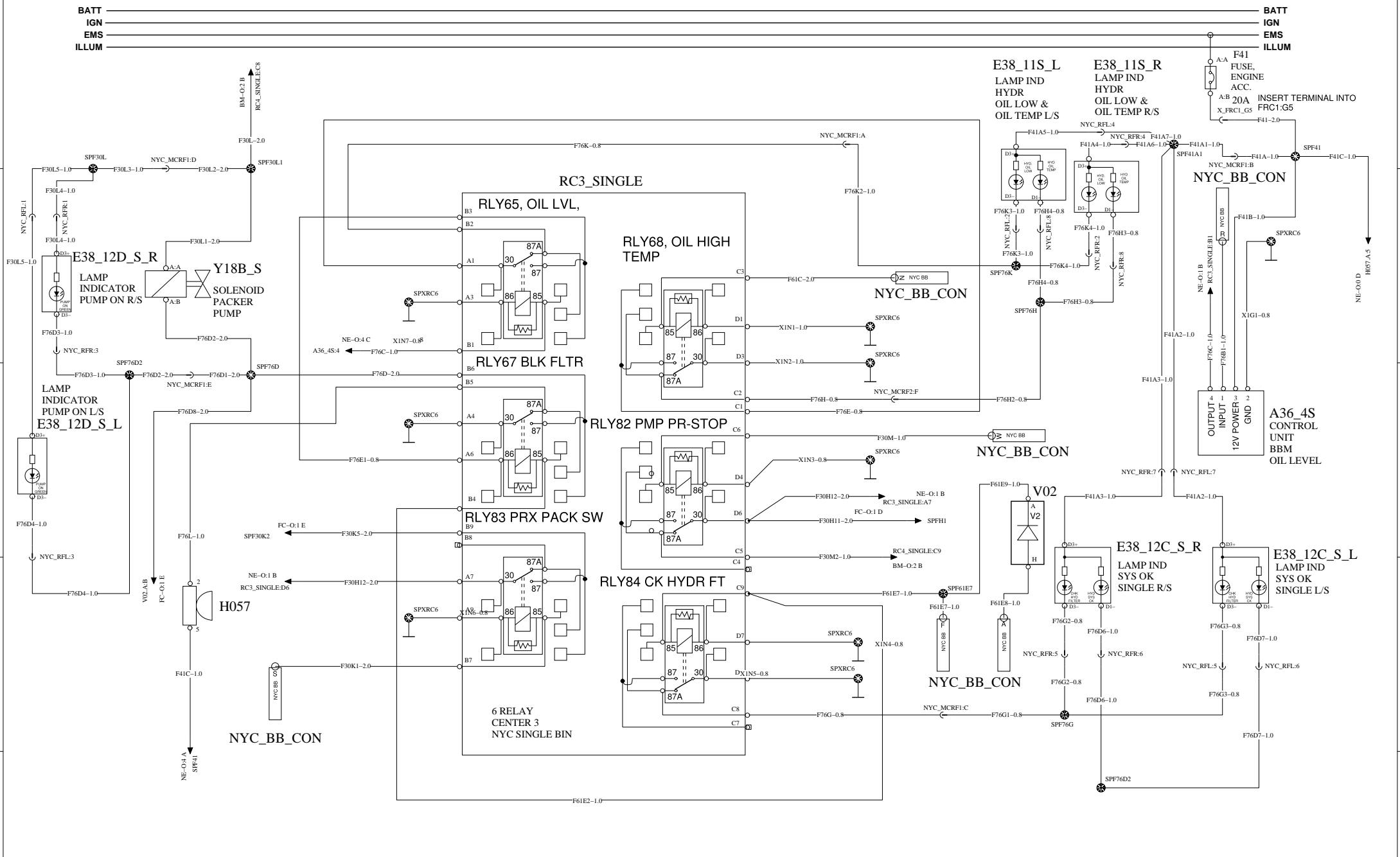

Mack Trucks Inc.

Document title
WIRING DIAGRAM - TYPE OL L1EH1 - NYC DS

Document type
<https://www.truckmanuals.net/>

Drawing No.
22617224

Revision
02

Page
14 (16)

NYC_SINGLE_DUAL_BIN_ELECTRIC_FUEL_PRIMER_PUMP_&_VENT_FANS

WIRING DIAGRAM: NF-O

BATT
IGN
EMS
ILLUM

BATT
IGN
EMS
ILLUM

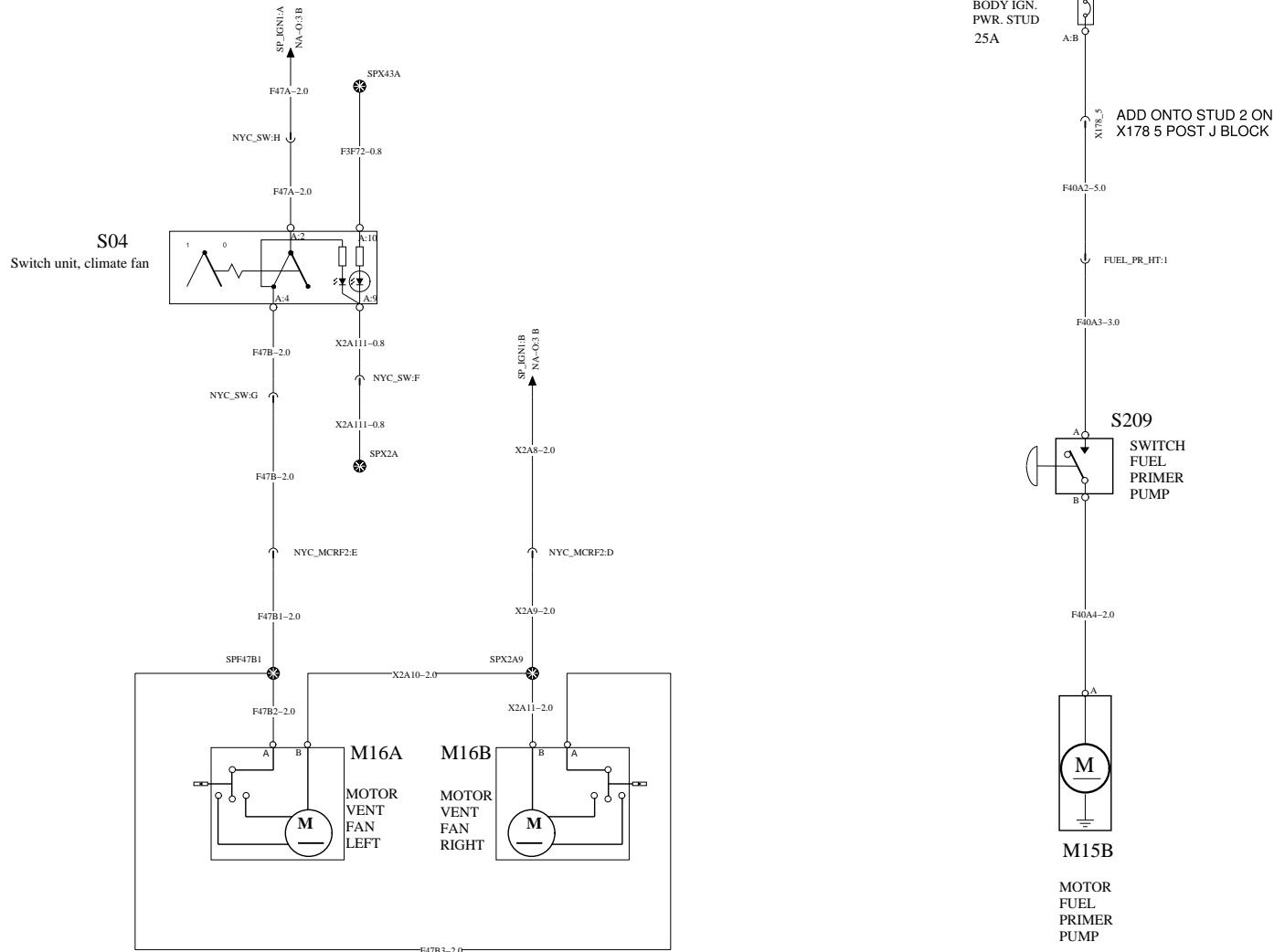

MACK

Mack Trucks Inc.

Document title
WIRING DIAGRAM - TPE OL L1EH1 - NYC DS

Document type

Drawing No.

22617224

Revision

02

Page

15 (16)

<https://www.truckmanuals.net/>

BATT
IGN
EMS
ILLUM

