

20 660 - GB - 02/2004

ENGINE - DCI 11

RANGE	FAMILY	VARIANT
KERAX	33AA P 8X4	12094
	33BB P 8X4	
	33CC P 8X4	
	33DD P 8X4	
	33GG P 6X4	
	33HH P 6X4	
	33II P 6X4	
	33JJ P 6X4	
	33KK T 6X4	
	33LL T 6X4	
	33MM P 6X6	
	33NN T 6X6	
	33PP P 4X2	
	33QQ T 4X2	
	33RR P 4X4	
33SS T 4X4		
PREMIUM	22AA P 4X2	
	22C T 4X2	
	22CC T 4X2	
	22EE P 6X2/4	
	22HA P 6X2/4	
	22JJ T 6X2 PUSHER	
	22QQ P 6X2	
	22RR T 6X2	



The above information may change in the course of time. Only the "Consult" section of the workshop manuals repertory in standard N° 10320 serves as reference.

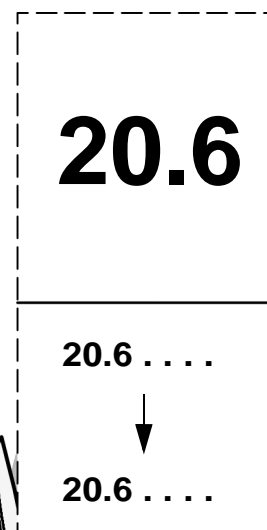
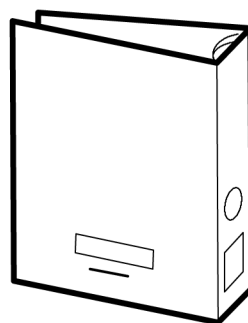
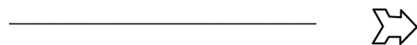
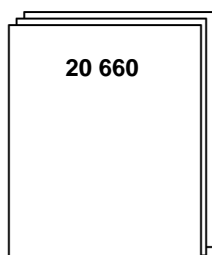

CONTENTS

Generalities	A-1 → 5
<hr/>	
Technical data	B-1 → 3
— General features	B1-2 → 7
— Tightening torques	B2-1 → 7
— Dimensions and tolerances	B3-1 → 10
<hr/>	
Tools / Consumables	C-1 → 13
<hr/>	
Stripping and mounting on stand	D-1 → 8
— Stand 1000	D1-2 → 4
— Belt tensioner	D2-1 → 2
— Compressor (air conditioner)	D3-1 → 1
— Alternator	D4-1 → 1
— Fan control	D5-1 → 1
— Damper	D6-1 → 2
— Starter	D7-1 → 1
— Engine brackets	D8-1 → 1
<hr/>	
Cylinder head	E-1 → 3
— Removal	E1-2 → 5
— Fitting	E2-1 → 7
— Disassembly/inspection/assembly	E3-1 → 6
<hr/>	
Valve timing	F-1 → 14
<hr/>	
Reciprocating gear	G-1 → 13
<hr/>	
Lubrication	H-1 → 2
— Oil filter	H1-2 → 2
— Centrifugal oil filter	H2-1 → 2
<hr/>	
Cooling	I-1 → 3
— Heat exchanger	I1-2 → 3
— Ventilation control	I2-1 → 3
— Water pump	I3-1 → 4
<hr/>	
Injection	J-1 → 2
— Generalities	J1-2 → 17
— Repair	J2-1 → 30

Diagnostics aid (setting B43)	K-1 → 17
Diagnostics aid (setting +J01)	L-1 → 23
Diagnostics aid (setting +J01) variant 14102	M-1 → 23
Turbocharger	N-1 → 4
Jake brake	O-1 → 7

GENERALITIES

Warnings

In this document, safety instructions are symbolized as follows:



DANGER! NON-OBSERVANCE OF THE PROCEDURE DESCRIBED OR LACK OF CARE OR ATTENTION, RISK CAUSING SERIOUS INJURY OR EVEN DEATH.



WARNING! Any different or inappropriate working method risks causing damage to the product.







NOTE! Draws attention to particular or important points of the method.













Comply without fail with the regulations in force relative to the recovery and treatment of used parts and waste.

Conventional symbols









Fitting

	Tighten to torque (Nm) (left-hand thread)		Tighten by indicated value
	Tighten to torque (Nm) (right-hand thread)		Loosen by indicated value
	Tightening torque with lubricated threaded hardware		









Dimensioning

	Tightening		... Greater than or equal to ...
	Equal to		Wear limit
	... Less than ...		Machining limit or dimension
	... Greater than ...		Maximum out-of-true
	... Less than or equal to ...		Maximum parallelism error



















Repair

	Force to be exerted in the direction shown (hammer - press)		Smear or coat (see "Consumables" table)
	Heat or cool: Temperature in degrees Celsius (e.g. + 80 °C)		Fill to level (see "Technical Data" and "Consumables" table)
	Weld bead		Grease or oil (see "Consumables" table)
	Repair time - Heating time		Mark - Assemble according to marking

Adjustment

	Rotating friction torque		Turn anti-clockwise
	Turn in alternate directions		Turn anti-clockwise (the figure shows the number of turns)
	Turn clockwise		Turn clockwise (the figure shows the number of turns)
	Place in contact		Move in the direction shown
	Dimension to be assured (mm)		

Various information

	Exhaust - Outlet		Operation with a sequence
	Intake - Inlet		Involves
	Weight in kg (example: 275 kg)		Return to numbered operation - Connected with numbered operation
	Depending on versions or options		Withdraw - Delete
	Wrong		Direction of disassembly (the arrow shows the direction)
	Correct		Direction of assembly (the arrow shows the direction)
	Injection		... to ...
	Repair dimension		Inspect - Check condition of part
	Part to be replaced		Danger for persons, vehicle or equipment

General instructions

Practical advice

Prior to any work:

- Clean the major unit and its surrounds (See Driving Servicing Handbook, "Vehicle washing").
- Ensure the batteries are disconnected.
- Mark the pipes and wiring harnesses, if necessary.
- Protect all ports to prevent the ingress of foreign matter.
- Before disconnecting an air pipe, drop the circuit pressure.
- If liquid is splashed onto the bodywork, clean quickly with a cleaning product recommended by RENAULT TRUCKS.

Preparation prior to assembly:

Carefully clean and check all the parts.

Do not unpack a new bearing until you are ready to install it. Do not clean off the protective grease on new bearings.

Old seals and lock-plates must be discarded and new ones fitted.

Never force fit parts with copper or brass punches or drifts. Always use a specially adapted driver to prevent ingress of metal particles into the casings and bearings. Always oil parts prior to force fitting.

Always apply grease on the inside of seal ring lips.

Shrink fitted parts are to be heated with a hot air blower or in an oven. etc. Flame heating is strictly forbidden.



When using a torque multiplier, calibrate the torque wrench/multiplier unit at the required torque loading.

Fastening, locking, sealing and adhesive products:

Prior to assembly, carefully clean the product application surfaces of the parts. Old product residue is to be removed. Threaded portions are to be brushed, tapped and, if necessary, cleaned with a suitable product.

Using the product:

Always adapt the recommended product while observing the utilization conditions appearing on the pack:

- Surface finish,
- Working temperature,
- Reaction, drying, etc. time,
- Shelf life.

Observe the assembly method so as to guarantee the quality of the repair.

TECHNICAL DATA

General features

Identification plate 14102 (original engine)*

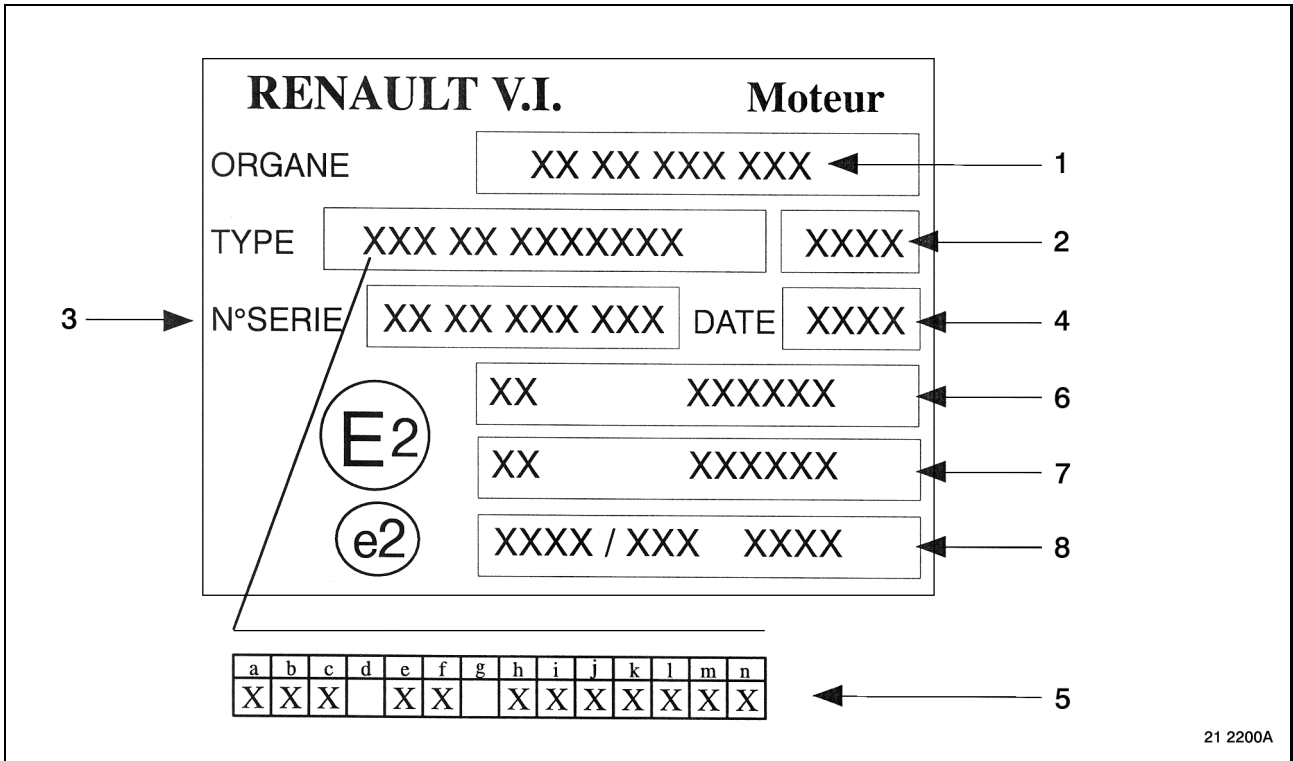

- 1: Spare Parts Reference N°
- 2: Family N°
- 3: Manufacturing N°
- 4: Manufacturing Date
- 5: Engine type (see symbolization)
- 6: Power rating
- 7: Smoke
- 8: Emissions

a	D	Diesel
b	C	Common Rail
c	I	Injection
d		
e	11	Capacity: 11: 11 litres 6: 6 litres 4: 4 litres
f		
g		
h	B	
i		
j	+	+ : Multi-mode (several power ratings available) Blank space: Single-mode (one single power rating available)
k	J	Month of application of pollutant emissions regulation: A: January B: February C: March L: December
l	01	Year of application of pollutant emissions regulation: 00: 2000 01: 2001 02: 2002
m		
n		Post-combustion equipment (particulate filter): Blank space or 0: without 1: with

Identification plate (original engine)*

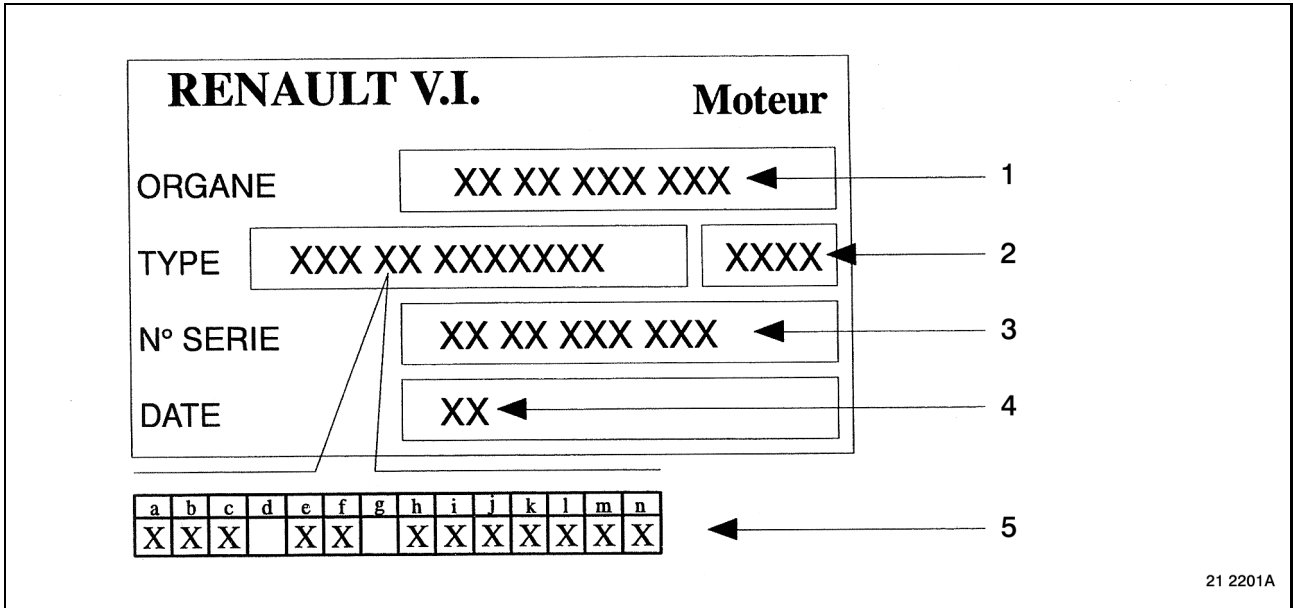

21 2201A

- 1: Spare Parts Reference N°
- 2: Family N°
- 3: Manufacturing N°
- 4: Manufacturing Date
- 5: Engine type (see symbolization)

Service exchange engine

To identify service exchange engines: see Spare Parts department technical comments.

Symbolization

a	D	Diesel
b	C	Common Rail
c	I	Injection
d		
e	11	Capacity: 11: 11 litres 6: 6 litres 4: 4 litres
f		
g		
h	B	
i		
j	+	+ : Multi-mode (several power ratings available) Blank space: Single-mode (one single power rating available)
k	J	Month of application of pollutant emissions regulation: A: January B: February C: March L: December
l	01	Year of application of pollutant emissions regulation: 00: 2000 01: 2001 02: 2002
m		
n		Post-combustion equipment (particulate filter): Blank space or 0: without 1: with

Technical data

Power setting index	B43 / B+J01 / C+J01 / E+J01 / F+J01 / G+J01 / H+J01 / I+J01
Cubic capacity	11 l
Compression ratio	17/1
Firing order	1.5.3.6.2.4
n°1 cylinder:	flywheel end
Engine rotation	clockwise
Fuel:	diesel fuel
Supercharged:	by turbocharger with intercooler

Cooling:

Circulating coolant activated by thermostat-regulated pump.

Beginning of opening:	83 °C
End of opening:	90 °C
Min. full opening dimension:	9.4 mm

Arctic cold cooling pack:

Circulating coolant activated by thermostat-regulated pump.

Beginning of opening:	88 °C
End of opening:	98 °C
Min. full opening dimension:	9.4 mm

Lubrication

Oil pressure (dCi 11 B43)

Engine speed in rpm	Block rail	
	Temperature in °C	Pressure in bar
1000	85	2.9
2100		4.8

Oil pressure (dCi 11 J+01)

Engine speed in rpm	Filter head		Block rail	
	Temperature in °C	Pressure in bar	Temperature in °C	Pressure in bar
1000	85	2.7	85	2.5
2000		4.7		4.3

Lubrication:

forced by gear pump

Oil: specifications and operating temperatures (see Driving & Servicing handbook).

Oil capacity: (see Driving & Servicing handbook).

Tightening torques

Definitions

There are several types of tightening:

- Tightening to torque (in **Nm**)
- Tightening to angle (in °)
- Tightening to torque-angle (en **Nm + °**)

Torques given in **Nm** are nominal torques (average value calculated on the basis of the minimum torque and the maximum torque).

The tightening precision class defines the tolerance of this torque in percent as a function of the nominal torque applied.

Tightening precision classes:

- **Class I:** Special threaded hardware (tolerances $\pm 10\%$ of the final torque).
- **Class II:** Reserved for precise tightening (tolerance $\pm 10\%$ of the nominal torque).
- **Class III: Reserved for normal standard tightening** (tolerance $\pm 20\%$ of the nominal torque).

For standard threaded hardware indicated in the table below, use tightening class **III**.

For other torques, see the following page(s).



"FIH" type (Nylstop) locknuts must be replaced whenever removed. "DRH" type (oval) locknuts can be re-used. If locknuts (DRH, FIH or other) are re-used, make absolutely certain that the screw-thread of the bolt protrudes least two threads above the top edge of the nut.

Standard nut and bolt tightening torques table



The tightening torque values given in the table are based on standard 01.50.4002 and apply to new nuts and bolts fitted dry and re-used nuts and bolts with oil applied to the screw-threads. If any nuts and bolts are replaced, **it is absolutely essential to use nuts and bolts recommended by the RENAULT TRUCKS Spare Parts Department (coefficient of friction in compliance with standard 01.50.4002).**

Tightening torque values in Nm for conventional "metric system" threaded hardware based on standard 01.50.4002 (H: normal and HE: with flange)		
dia. and pitch of nuts and bolts	Quality class III	
	Quality class 8.8	Quality class 10.9
6 x 1.00	7.5 ± 1.5	11 ± 2.2
7 x 1.00	15 ± 3	20 ± 4
8 x 1.00	20 ± 4	30 ± 6
8 x 1.25	20 ± 4	27 ± 5.4
10 x 1.00	40 ± 8	60 ± 12
10 x 1.25	40 ± 8	60 ± 12
10 x 1.50	40 ± 8	50 ± 10
12 x 1.25	70 ± 14	100 ± 20
12 x 1.50	65 ± 13	95 ± 19
12 x 1.75	60 ± 12	90 ± 18
14 x 1.50	105 ± 21	155 ± 31
14 x 2.00	100 ± 20	145 ± 29
16 x 1.50	160 ± 32	220 ± 44
16 x 2.00	150 ± 30	220 ± 44
18 x 1.50	240 ± 48	340 ± 68
18 x 2.50	210 ± 42	310 ± 62
20 x 1.50	330 ± 66	480 ± 96
20 x 2.50	300 ± 60	435 ± 87
22 x 1.50	450 ± 90	650 ± 130
22 x 2.50	410 ± 82	595 ± 119
24 x 2.00	560 ± 112	820 ± 164
24 x 3.00	510 ± 102	750 ± 150

Standard tightening torques table for union bolts with Cu gaskets and BS rings

Nominal tightening torque values for union bolts with CU gaskets and self-centring BS rings			
Nominal dia.	Tightening torque	Nominal dia.	Tightening torque
8	10 ± 2	16	40 ± 8
10	20 ± 4	18	50 ± 10
12	27 ± 5.4	22	80 ± 16
14	32 ± 6.4	24	80 ± 16

Cylinder head

Cylinder head securing bolt (see page E-2-1)	
Rocker shaft securing bolt (see page E-2-4)	
Cylinder head cover bolt (see page E-2-5)	
Inlet manifold securing bolt(see page E-2-6)	
Exhaust manifold securing bolt (see page E-2-6)	
Valve yoke adjusting nut	35 ± 7 Nm
Rocker arm adjusting nut	40 ± 8 Nm
Preheat plug(s)	41 ± 8 Nm
Heat insulating screen(s) setscrew	M8 = 20 ± 4 / M10 = 60 ± 12 Nm

Reciprocating gear

Crankshaft bearing cap securing bolt (see page G-7)	
Flywheel securing bolt (see page G-13)	
Connecting rod cap securing nut (see page G-10)	
Block stiffener securing bolt	30 ± 6 Nm
Flywheel housing setscrew	M14 = 150 ± 30 / M8 = 20 ± 4 Nm

Timing

Damper hub setscrew (see page F-11)	
Oil sump securing bolt (see page F-13)	20 ± 4 Nm
Oil sump securing nut (see page F-13)	20 ± 4 Nm
Oil sump securing stud (see page F-13)	20 ± 4 Nm
Fan bracket securing stud	20 ± 4 Nm
Camshaft stop securing bolt	(FRENETANCH 242) 20 ± 4 Nm
Tappet retaining pin setscrew	20 ± 4 Nm
Idler gear hub securing bolt	100 ± 20 Nm
Pulley to hub securing bolt	67 ± 7 Nm
Damper to hub securing bolt	120 ± 12 Nm
Alternator bracket securing stud	20 ± 4 Nm
Alternator bracket securing nut	60 ± 12 Nm
Alternator bracket securing bolt	cl 8.8 = 20 ± 4 Nm
Alternator bracket securing bolt	cl 10.9 = 30 ± 4 Nm

Air conditioning compressor bracket securing bolt	60 ± 12 Nm
Air compressor pinion securing nut 550 cm ³ (variant 33118)	137.5 ± 27.5 Nm
Air compressor pinion securing nut 442 cm ³ (variant 33124)	270 ± 20 Nm
Hydraulic pump pinion securing nut	60 ± 12 Nm
Hydraulic pump securing stud	30 ± 6 Nm
Oil pump securing bolt	20 ± 4 Nm
High pressure pump securing nut	195 ± 20 Nm
High pressure pump securing stud	(FRENETANCH 242) 20 ± 4 Nm
High pressure pump securing nut (tighten in diametrically opposed sequence, then retighten first nut only)	60 ± 12 Nm
Breather impeller setscrew	11 ± 1 Nm
Air conditioner and alternator tensioner setscrew	40 ± 8 Nm

Lubrication

Oil sump securing nut (see page F-13)	20 ± 4 Nm
Oil sump securing stud (see page F-13)	20 ± 4 Nm
Oil nozzle setscrew	20 ± 4 Nm
Oil pump securing bolt	20 ± 4 Nm
Oil aspiration tube setscrew	20 ± 4 Nm
Oil pump delivery pipe to block stiffener setscrew	20 ± 4 Nm
Oil sump drain plug	70 ± 14 Nm
Heat exchanger oil drain plug	40 ± 5 Nm
Centrifugal filter cover securing nut	30 ± 3 Nm
Centrifugal filter bracket/cover securing stud	(FRENETANCH 242) 30 ± 3 Nm
Oil level sender	50 ± 10 Nm

Jake brake

Mechanism to rocker shaft securing bolt (see page O-3)	60 ± 6 Nm + 120 ± 6°
Mechanism to cylinder head securing bolt	65 ± 7 Nm
Solenoid valve to mechanism	7 ± 0.7 Nm
Slave piston adjusting nut	40 ± 4 Nm

Turbocharger

Turbocharger to exhaust manifold securing bolt	60 ± 12 Nm
Exhaust brake to turbocharger securing nut	(GRAISSE GRIPCOTT NF) 20 ± 4 Nm
Exhaust brake to turbocharger securing stud	(GRAISSE GRIPCOTT NF) 10 ± 2 Nm
Lube tube union nut	24 ± 4.8 Nm

Cooling

Water pump securing bolt	20 ± 4 Nm
Fan bracket securing stud	20 ± 4 Nm
Fan bracket securing nut	60 ± 12 Nm
Fan pulley securing bolt	150 ± 30 Nm
Fan drive belt tensioner securing bolt	(FRENETANCH 242) 40 ± 8 Nm
Heat exchanger tube coolant drain plug	40 ± 5 Nm

Air compressor

Air compressor pinion securing nut 550 cm3 (variant 33118)	137.5 ± 27.5 Nm
Air compressor pinion securing nut 442 cm3 (variant 33124)	270 ± 20 Nm
Air compressor securing stud 550 cm3 (variant 33118)	(FRENETANCH 242) 30 ± 6 Nm
Air compressor securing stud 442 cm3 (variant 33124)	(FRENETANCH 242) 30 ± 6 Nm
Air compressor securing nut 550 cm3 (variant 33118)	40 ± 8 Nm
Air compressor securing nut 442 cm3 (variant 33124)	60 ± 8 Nm
Air compressor securing bolt 550 cm3 (variant 33118)	(FRENETANCH 242) 20 ± 4 Nm
Air compressor securing bolt 442 cm3 (variant 33118)	(FRENETANCH 242) 60 ± 12 Nm
Coolant pipe union nut	25 ± 5 Nm

Sensors

Coolant temperature sensor	18 ± 5 Nm
Speed sensor	7.5 ± 1.5 Nm
Oil pressure sensor	(FRENÉTANCH 242) 18 ± 5 Nm
Oil temperature sensor	18 ± 5 Nm
Oil level sender	50 ± 10 Nm
Common rail pressure sensor	60 ± 5 Nm
Pressure and boost air sensor setscrew	6.5 ± 1.5 Nm

Fuel-Injection

High pressure pipe gallery union nut (see page J-2-6)	
Cylinder head fuel delivery pipe nut (see page J-2-10)	
Injector nozzle-holder flange setscrew (see page J-2-11)	
High pressure pump securing nut	195 ± 20 Nm
High pressure pump securing stud	(FRENÉTANCH 242) (+ Loctite Frenétanch) 20 ± 4 Nm
High pressure pump securing nut (tighten in diametrically opposed sequence, then retighten first nut only)	60 ± 12 Nm
Booster pump securing bolts (tighten in diametrically opposed sequence)	8 ± 1 Nm
High pressure pump speed sensor setscrew	8 ± 1 Nm
Scavenge valve	30 + 10 Nm
Scavenge valve plug	15 + 5 Nm
Pressure and boost air sensor setscrew	6.5 ± 1.5 Nm
Flow limiter	85 ± 5 Nm
Pressure limiter to common rail	45 ± 5 Nm
Common rail pressure sensor	35 ± 5 Nm
ECU cooler piping setscrew	8 ± 1.5 Nm
Injector supply wire securing nut	1 ± 0.25 Nm
Accelerator pedal sensor setscrew	10 ± 2 Nm
Pressure sensor to rail union	45 ± 5 Nm
Fuel leak-off return pipe to pressure limiter union	30 ± 3 Nm
Fuel leak-off return union setscrew	12 ± 2.4 Nm
Low pressure polyamide pipes securing clamp nut	15 ± 3 Nm
High pressure pump oil filler plug	35 ± 5 Nm

Polyamide pipe union nut	28 ± 2 Nm
Wiring harness to engine block attaching clamp screw	30 ± 6 Nm
Fuel low pressure and leak-off return pipes securing nut on clips	3.5 ± 0.7 Nm

Dimensions and tolerances

Cylinder head

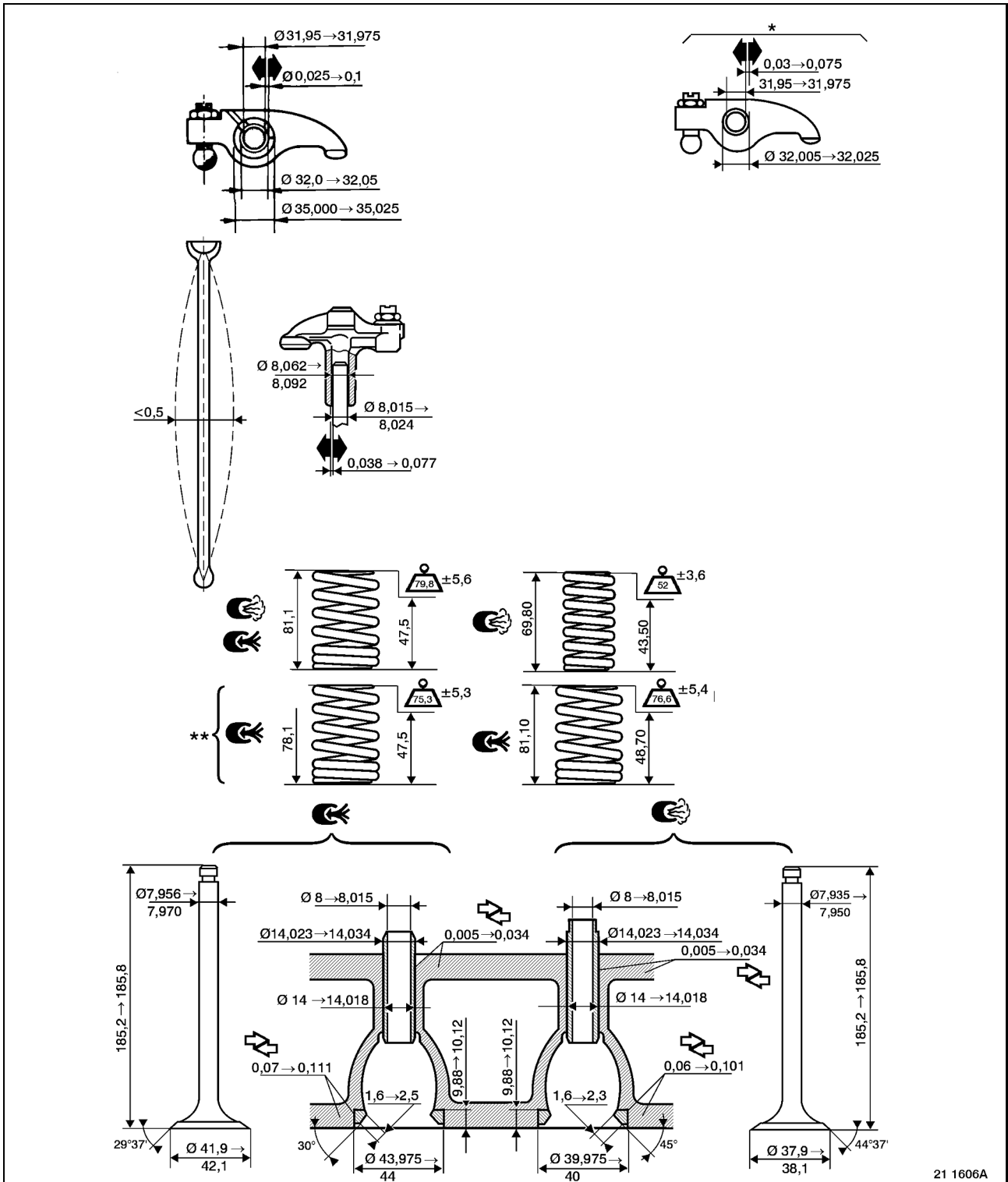

* Only for: dCi 11 B43

** With Jake brake

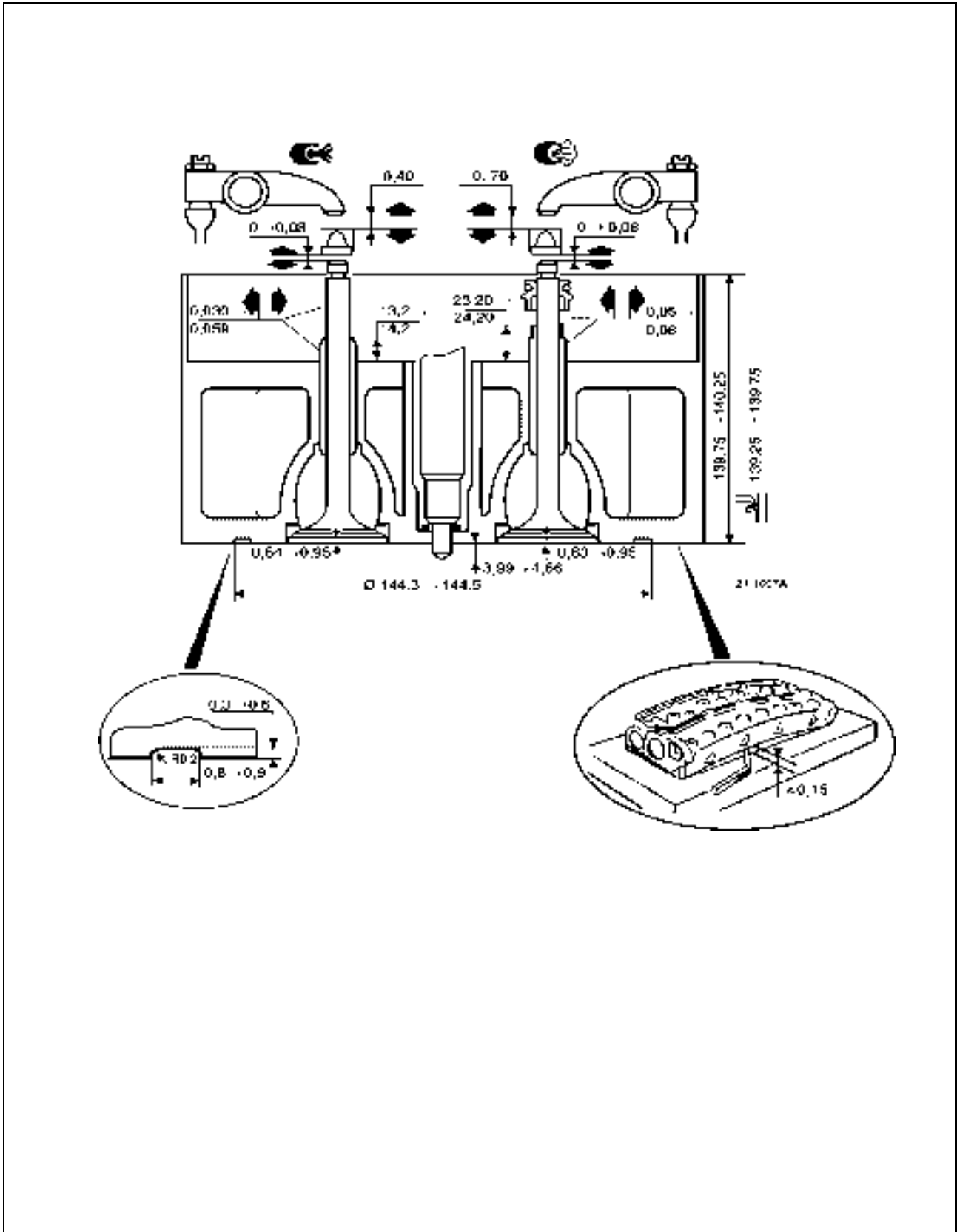

Timing

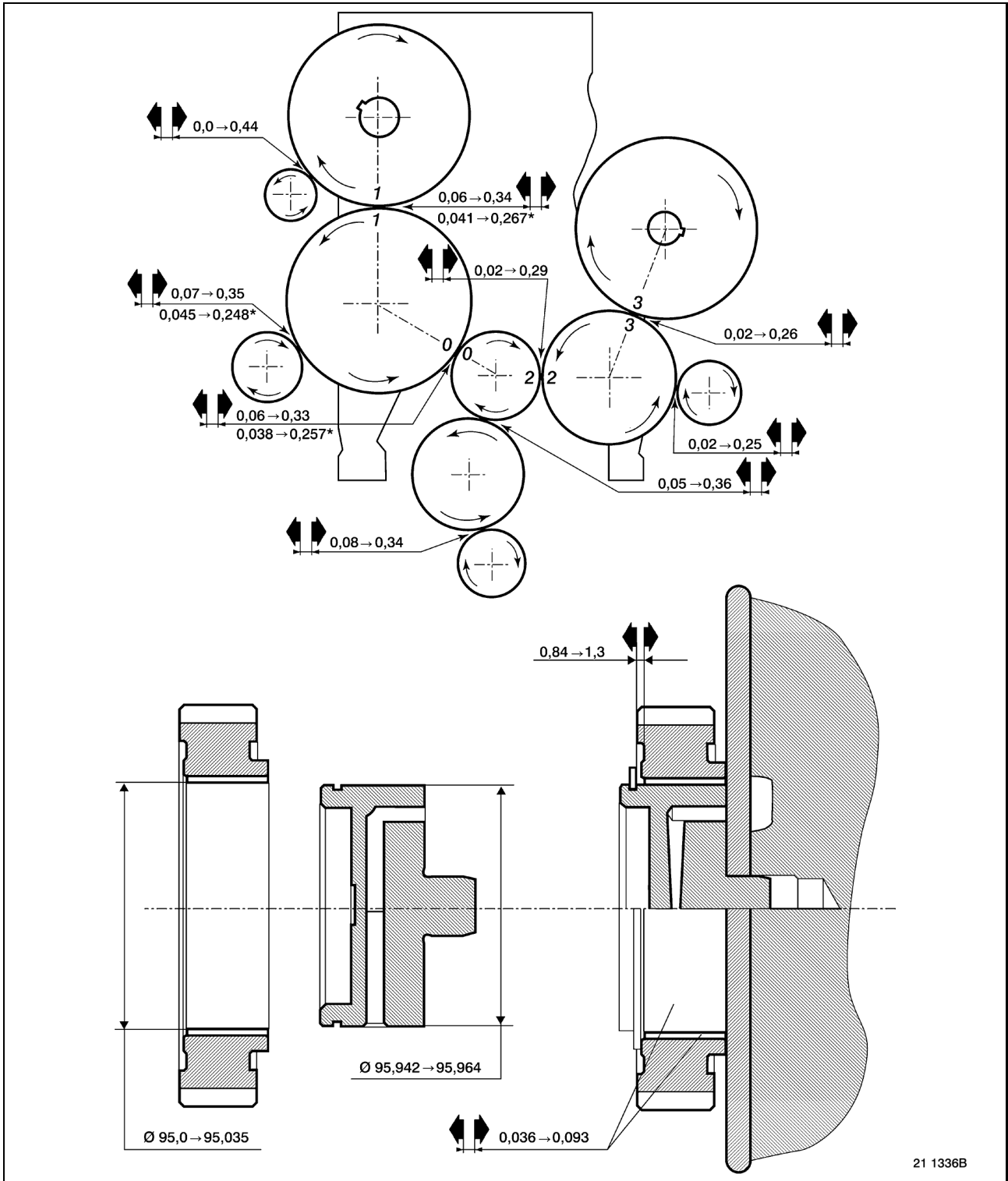

Clearance value with reduced play camshaft idler pinion N° 5010 550 239.

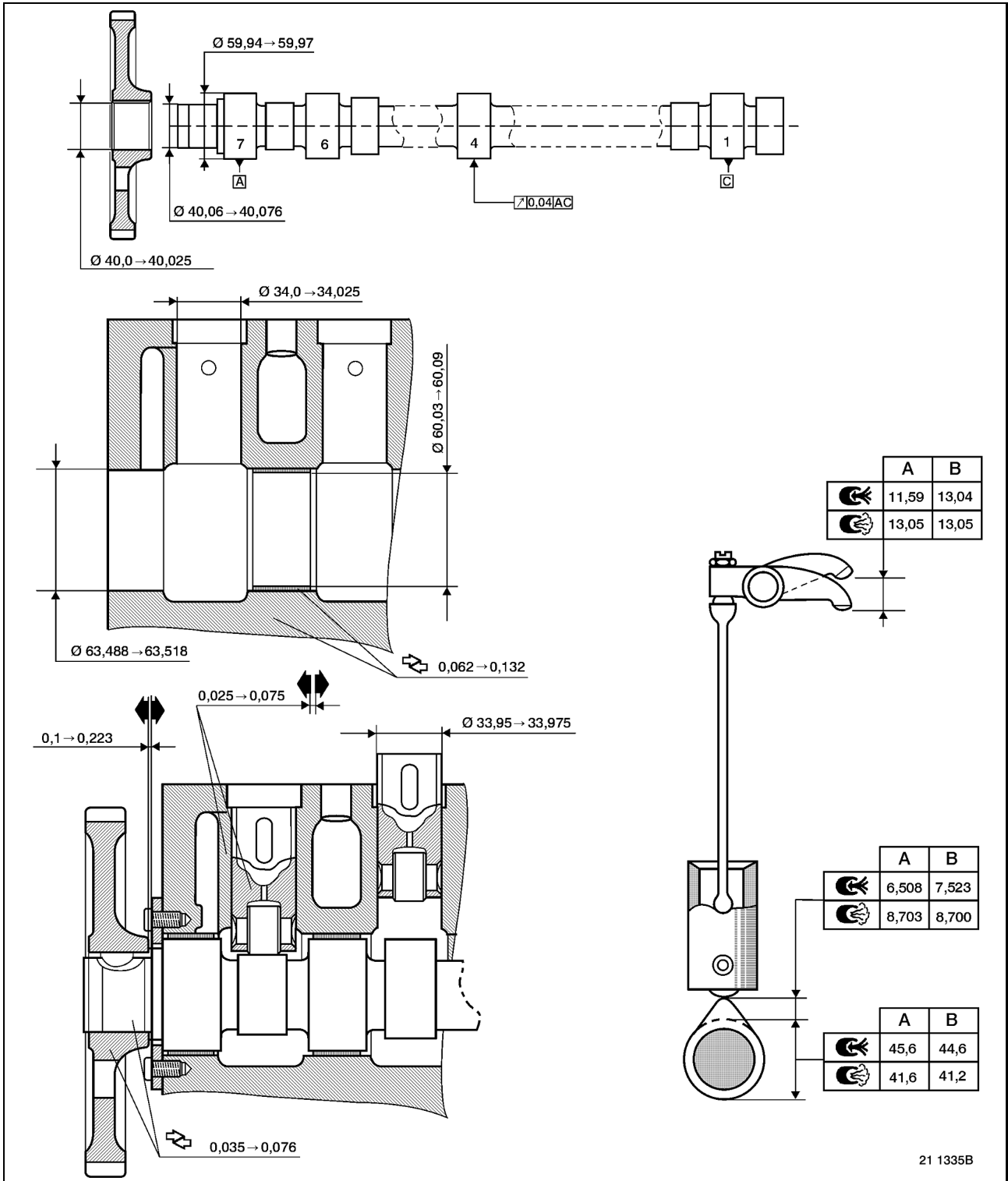

Engine with power setting A: dCi 11 B43.
 Engine with power setting B: dCi 11 + J01.

Quick timing check (dCi 11 B43):

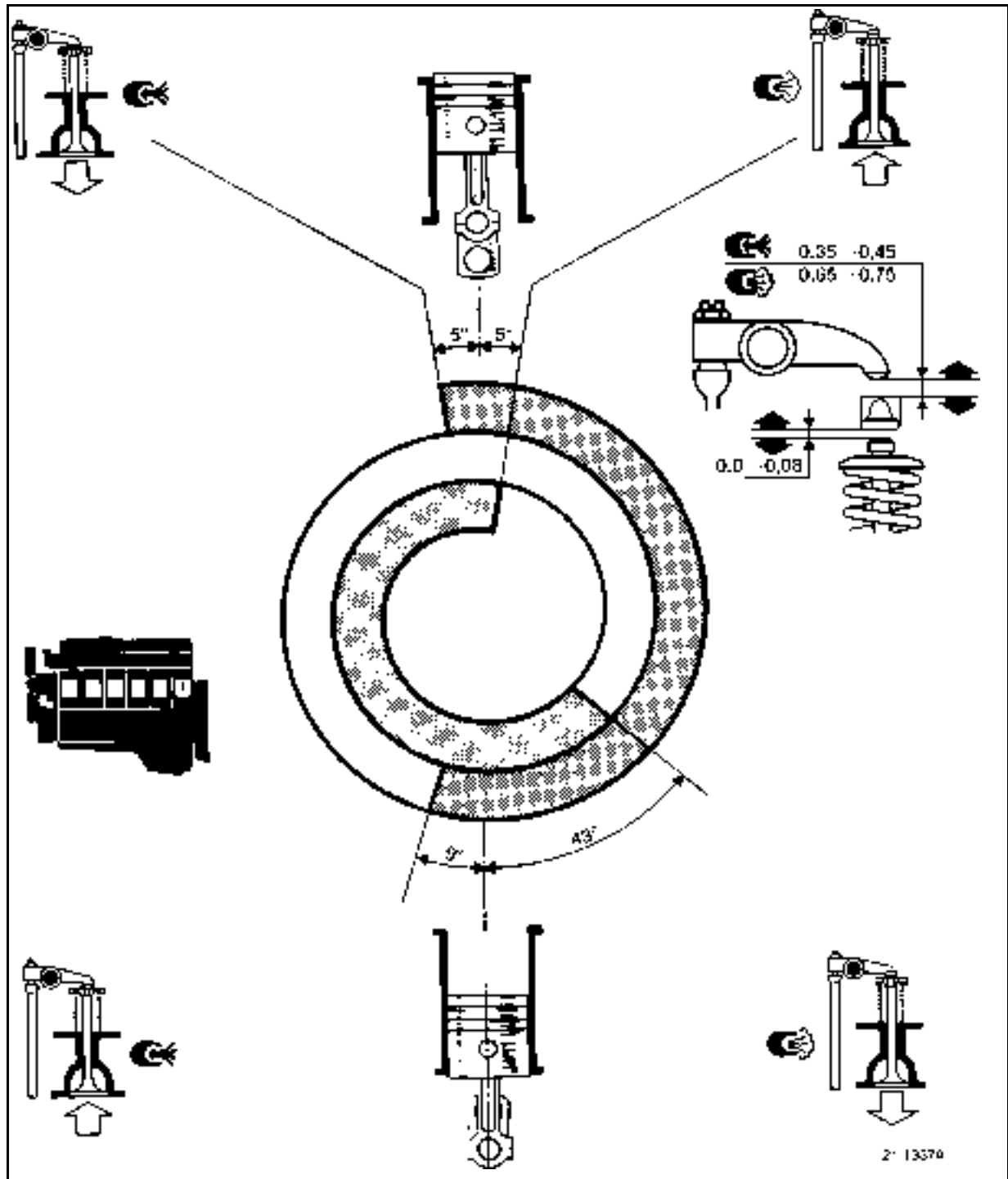

- Position the piston of N° 1 cylinder at end of exhaust/beginning of intake TDC (in the direction of rotation).
- Scribe a mark on the crankshaft pulley.
- Adjust the valve clearances to zero (without compressing the control springs)
- Crank the engine through one revolution while lining up the marks on the crankshaft pulley so as to arrive at "compression TDC".
- Check the valve clearances, which should be:
 - Inlet: **0.80 → 1.10 mm.**
 - Exhaust: **1.28 → 1.58 mm.**



Repeat this check twice so as to provide more accuracy when adjusting the rocker arm clearance to zero.

Quick timing check (dCi 11 + J01):

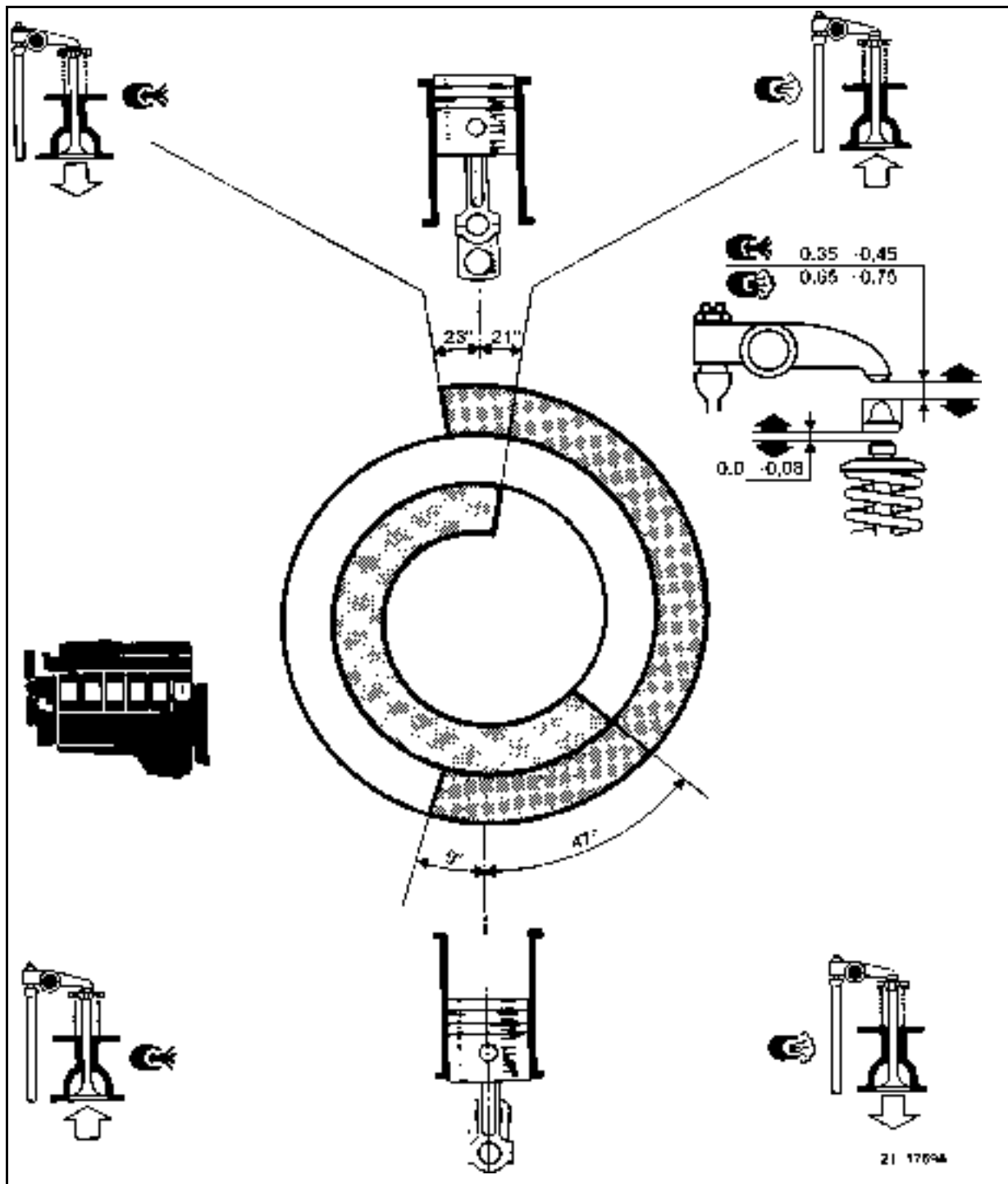

- Position the piston of N° 1 cylinder at end of exhaust/beginning of intake TDC (in the direction of rotation).
- Scribe a mark on the crankshaft pulley.
- Adjust the valve clearances to zero (without compressing the control springs)
- Crank the engine through one revolution while lining up the marks on the crankshaft pulley so as to arrive at "compression TDC".
- Check the valve clearances, which should be:
 - Inlet: **1.85 → 2.85 mm.**
 - Exhaust: **1.80 → 2.50 mm.**



Repeat this check twice so as to provide more accuracy when adjusting the rocker arm clearance to zero.

Reciprocating gear

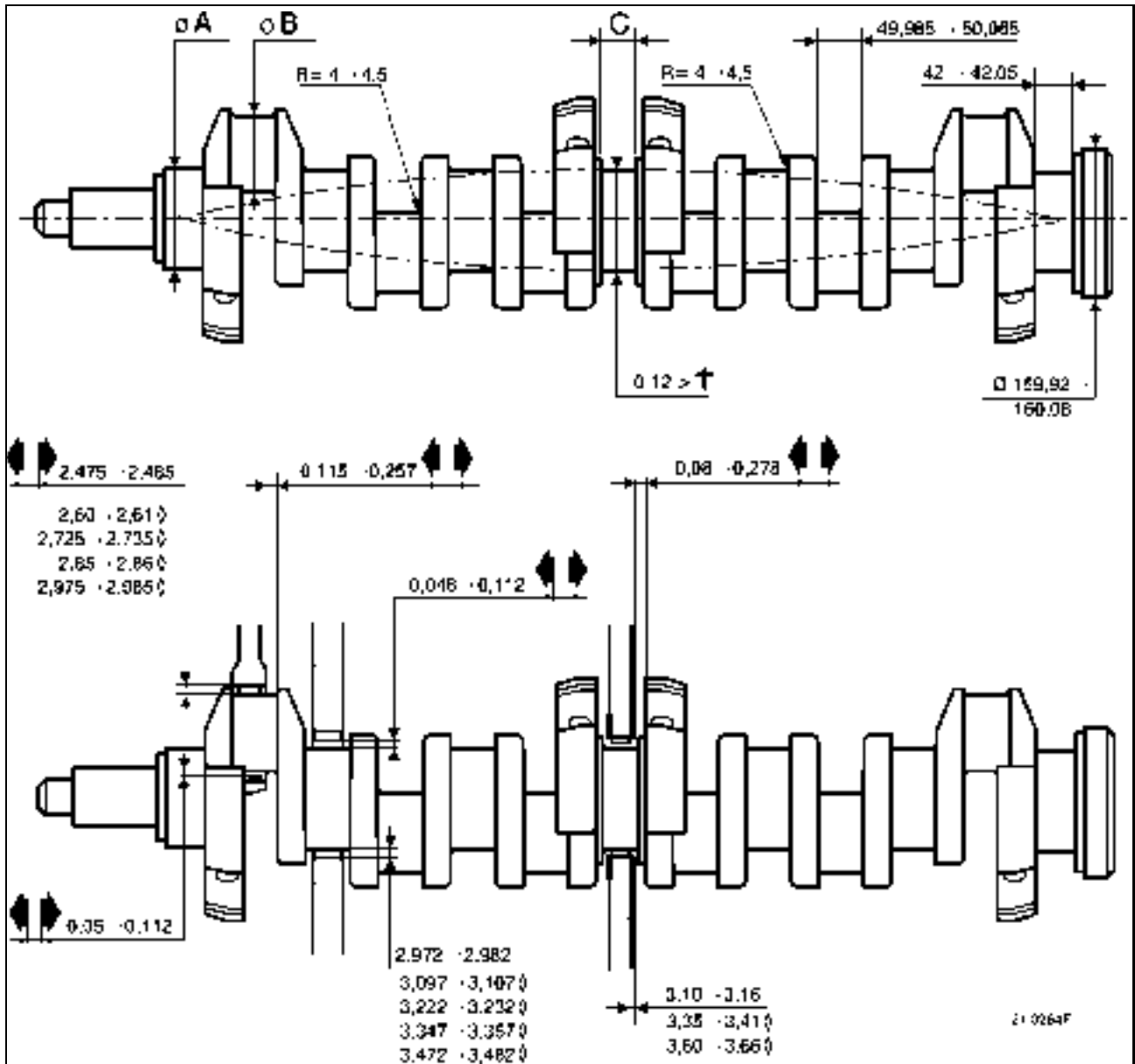

	$\varnothing A$	$\varnothing B$	C
	101.966 → 101.988	76.96 → 76.98	42.40 → 42.439
-0.25	101.716 → 101.738	76.71 → 76.73	42.90 → 42.939
-0.50	101.466 → 101.488	76.46 → 76.48	
-0.75	101.216 → 101.238	76.21 → 76.23	43.40 → 43.439
-1.00	100.966 → 100.988	75.96 → 75.98	

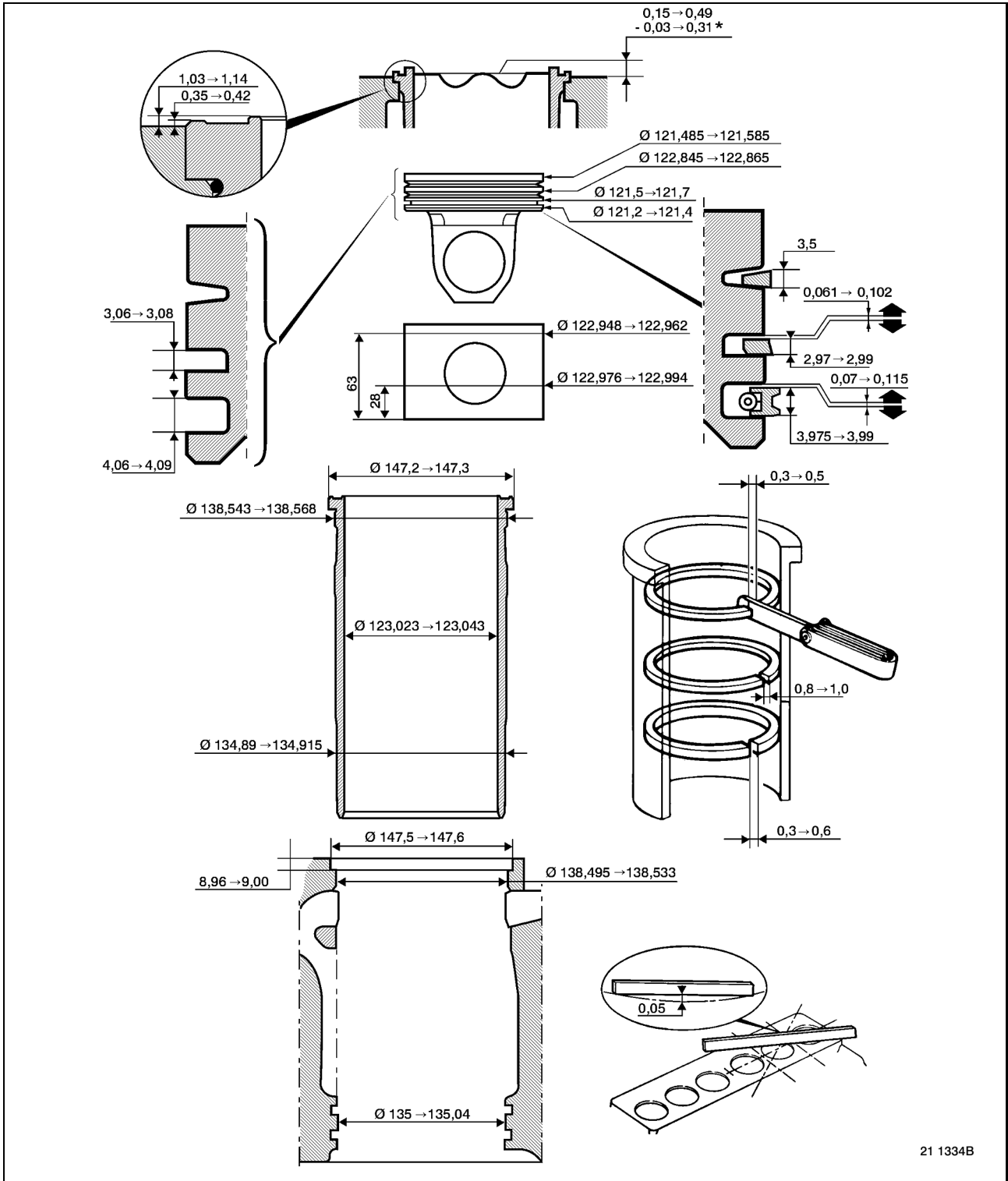

21 1334B

* Only for: dCi 11 B43

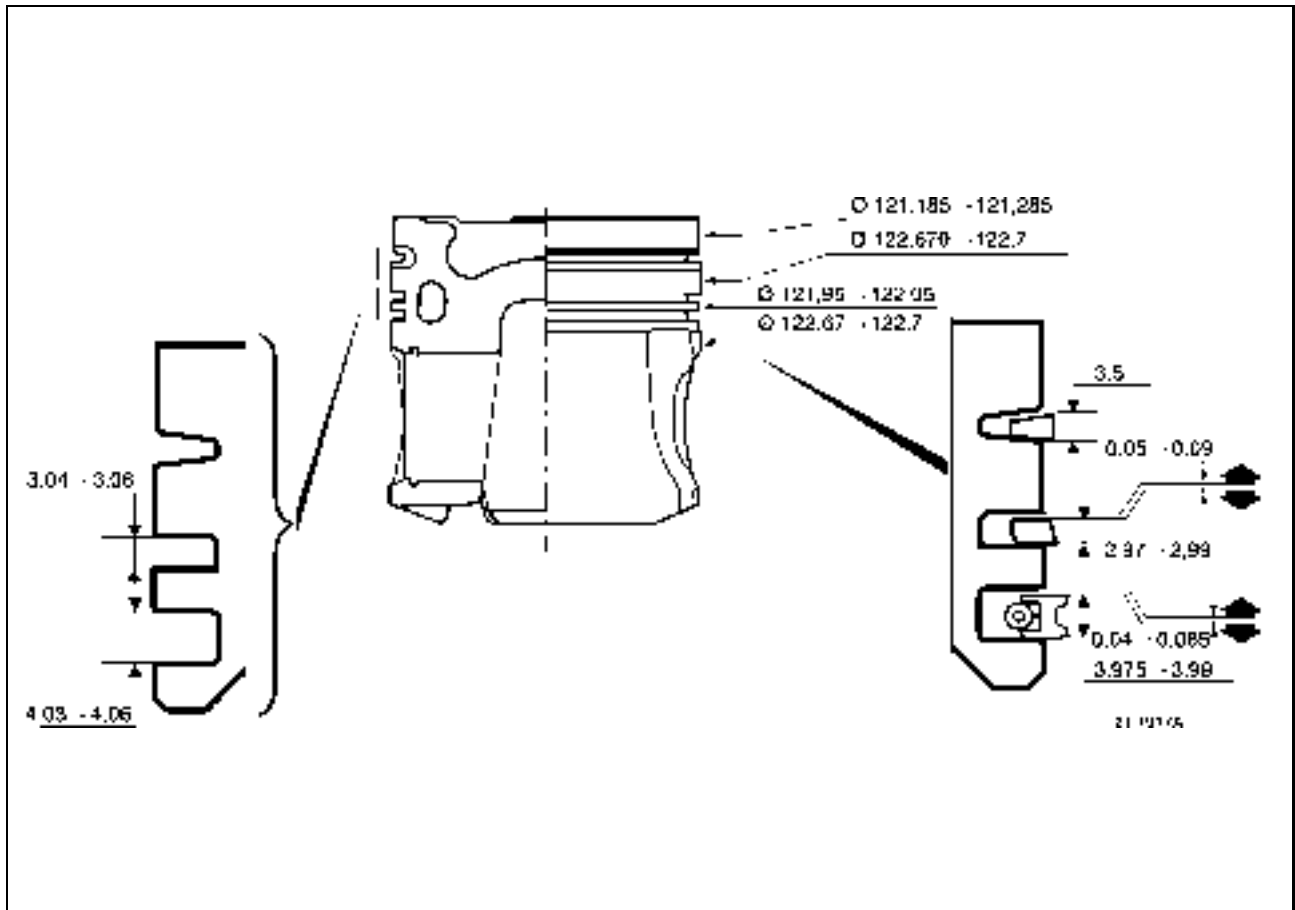

Only for: dCi 11 (variant 14102) E+J01, G+J01, I+J01, F+J01, H+J01 .

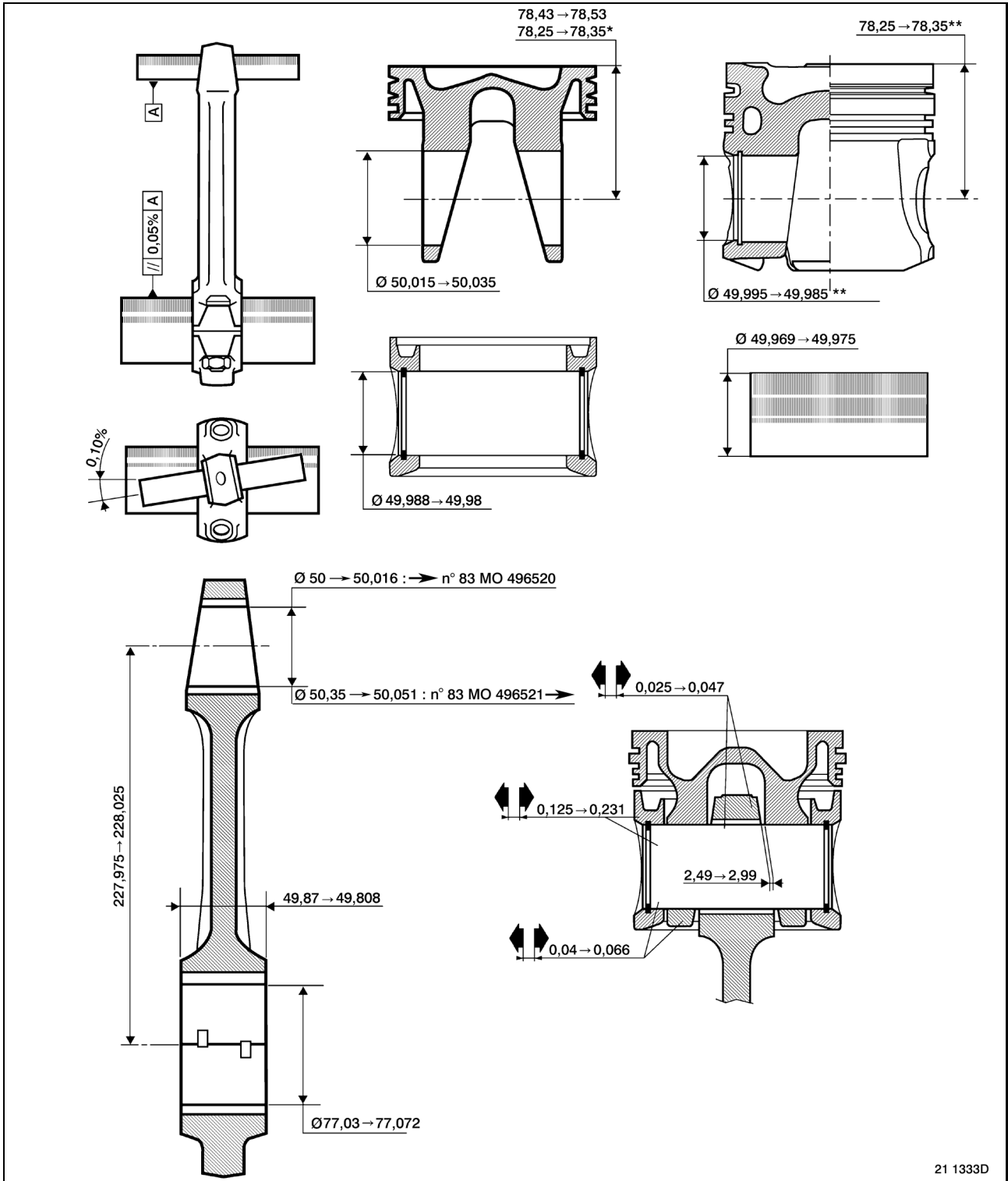

21 1333D

* Only for: dCi 11 B43

** Only for: dCi 11 (variant 14102) E+J01, G+J01, I+J01, F+J01, H+J01.

TOOLS / CONSUMABLES

Generalities

RENAULT TRUCKS divide tools into three categories:

- **General-purpose tools: proprietary tools.**
 - **50 00 26 reference number** (possibility of purchasing through the RENAULT TRUCKS Spare Parts department).
 - **4-figure reference number** (tools classified by RENAULT TRUCKS but available from the supplier).
- **Special tools:** specifically created tools distributed by the RENAULT TRUCKS Spare Parts Department.
- **Locally manufactured tools:** these tools are classified differently according to their degree of sophistication:
 - **4-figure reference number** (represented by a drawing): tools that are simple to make without need for special qualification.
 - **50 00 26 reference number** (possibility of purchasing through the RENAULT TRUCKS Spare Parts department): a certain amount of skill is needed to make these tools.

Three levels (or echelons) determine their assignment:







- **Level 1:** tools for servicing, maintenance and minor tasks.
- **Level 2:** tools for major repairs.
- **Level 3:** tools for refurbishment.



*Proprietary tools mentioned in this manual do not appear in the tools list.
These tools are identified in the standard tools manual (MO) by a 4-figure number.*

LIST OF TOOLS







General-purpose tools



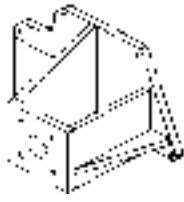

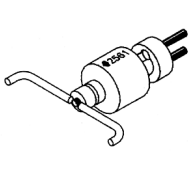

Illustration	RENAULT TRUCKS Ref.	Designation	Manufacturer reference	Manufacturer code	Level	Qty
	5000261000	UNIVERSAL STAND			1	1
	5000269777	ANGULAR DIAL			1	1
	9732	BOX OF CUTTERS	CN 109 B	AF	1	1
	5000260843	PULLER			1	1
	5000262351	SET OF PUSHERS			1	1
	5000260825	PISTON RING CLAMP			1	1
	5000261246	PRESSURE GAUGE			1	1





	50 00 26 2565	WRENCH		AB	1	1
---	----------------------	--------	--	----	---	---

AF	CEVMI					
	15, avenue Paul Doumer					
	75116 PARIS				FRANCE	
	☎ 01 45 53 97 03			📠 01 45 53 37 05		
AB	FACOM					
	6 et 8, rue Gustave Eiffel BP 99					
	91423 MORANGIS CEDEX				FRANCE	
	☎ 01 64 54 45 45			📠 01 69 09 60 93		



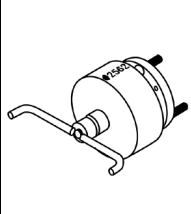



Special Tools

Illustration	RENAULT TRUCKS Ref.	Designation	Manufacturer reference	Manufacturer code	Level	Qty
	5000262542	FITTING			1	1
	5000262322	SOCKET			1	1
	5000261380	CONTROL			1	1
	5000269838	COMPRESSING TOOL			1	1
	5000261205	PULLER			1	1
	5000262549	SEAL PLATE			1	1
	5000263016	HANDLE			1	1

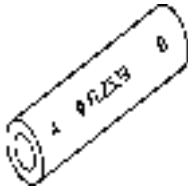
	5000262363	SET OF PUSHERS			1	1
	5000262556	GUIDE			1	1
	5000261220	PUSHER			1	1
	5000261281	PULLER			1	1
	5000261282	PUSHER			1	1
	5000262561	PUSHER			1	1
	5000261230	PULLER			1	1
	5000262334	FLANGE			1	1

	5000262560	GUIDE			1	1
	5000262562	PUSHER			1	1
	5000262655	FILTER WRENCH			1	1
	5000262589	UNCLIPPER			1	1
	5000262547	RETAINER			1	1

Locally manufactured tools

Illustration	RENAULT TRUCKS Ref.	Designation	Manufacturer reference	Manufacturer code	Level	Qty
	1462	SPACER			1	1
	2539	PUSHER			1	1
	FL 1332	PLATE			1	1
	2537	SOCKET			1	1
	2548	PLATE			1	1
	2513	TUBE			1	1
	2648	ENDPIECE			1	1

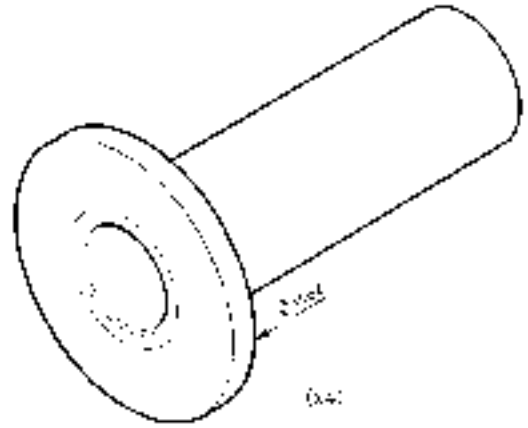
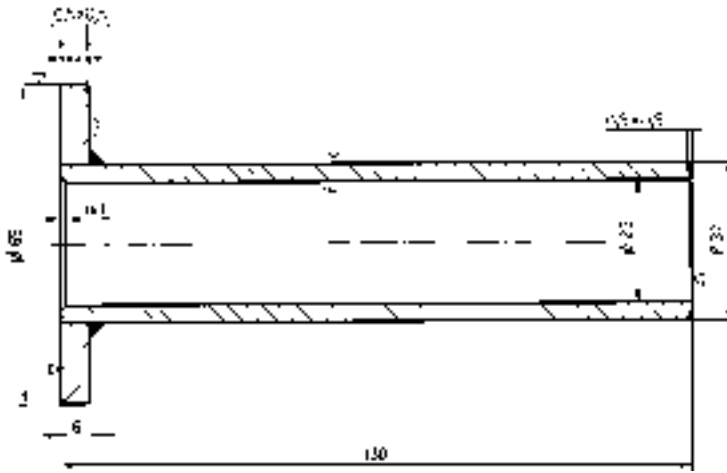

FL 1482

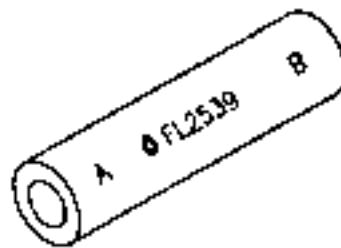
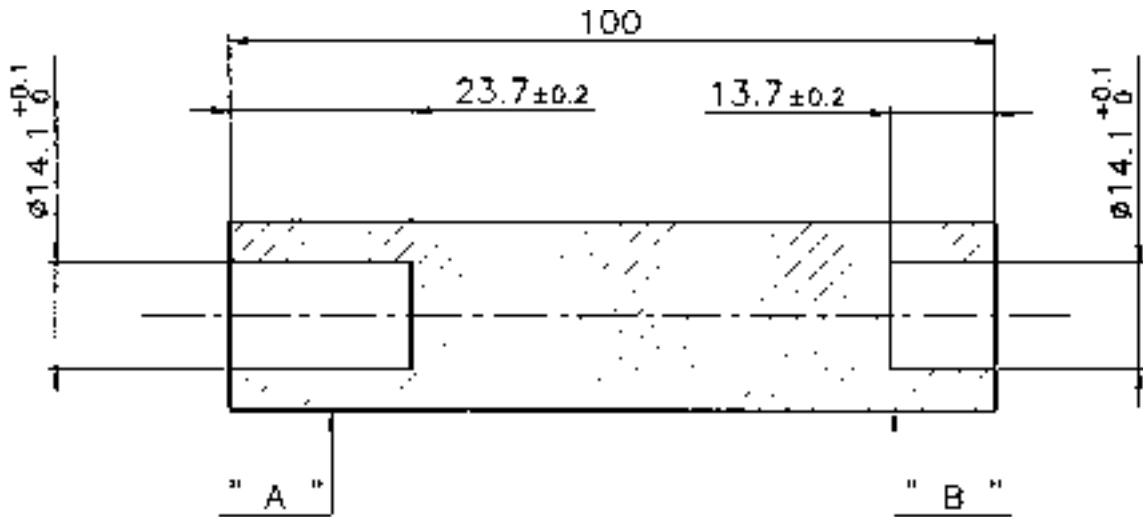

FL 2539

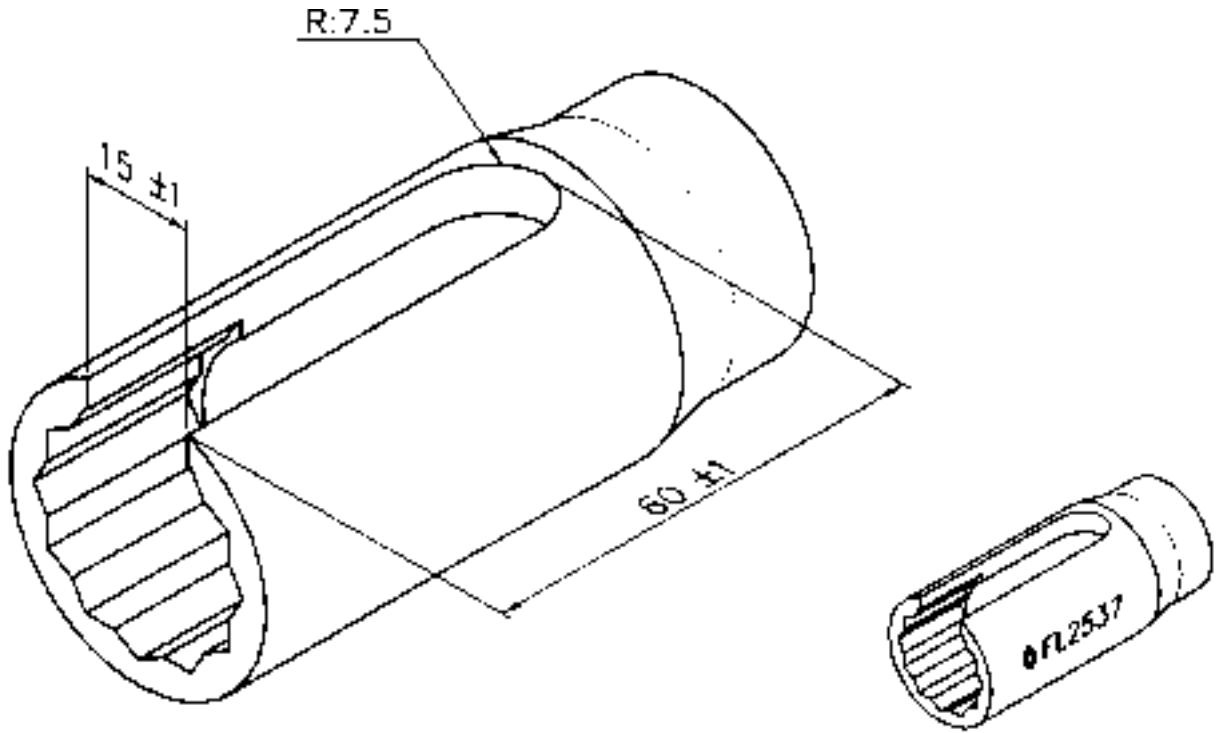

FACOM S 27 L

FL 2537

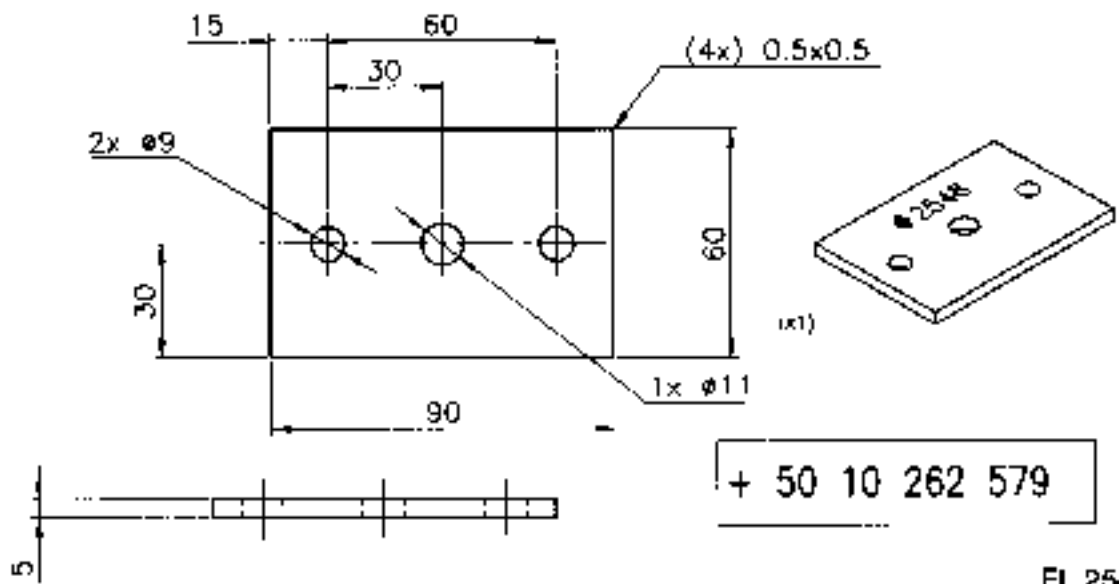
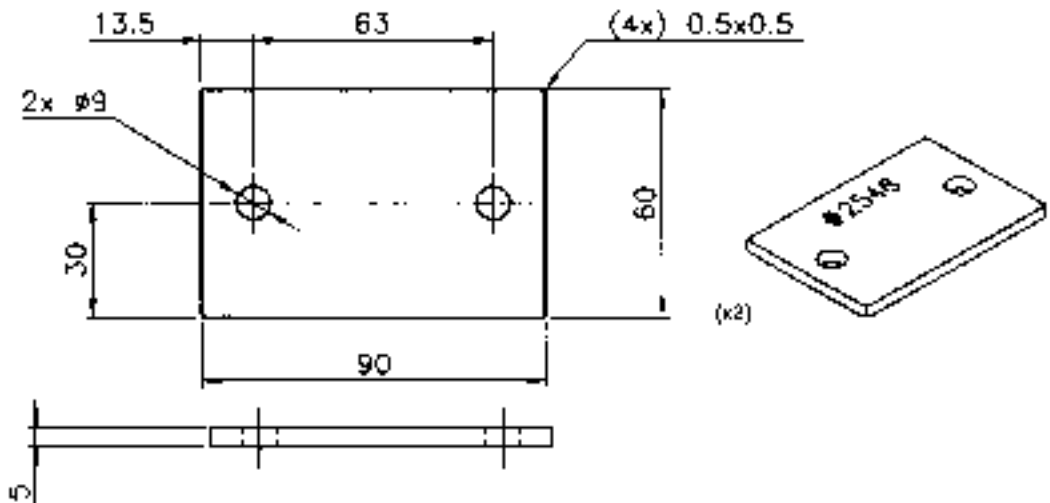
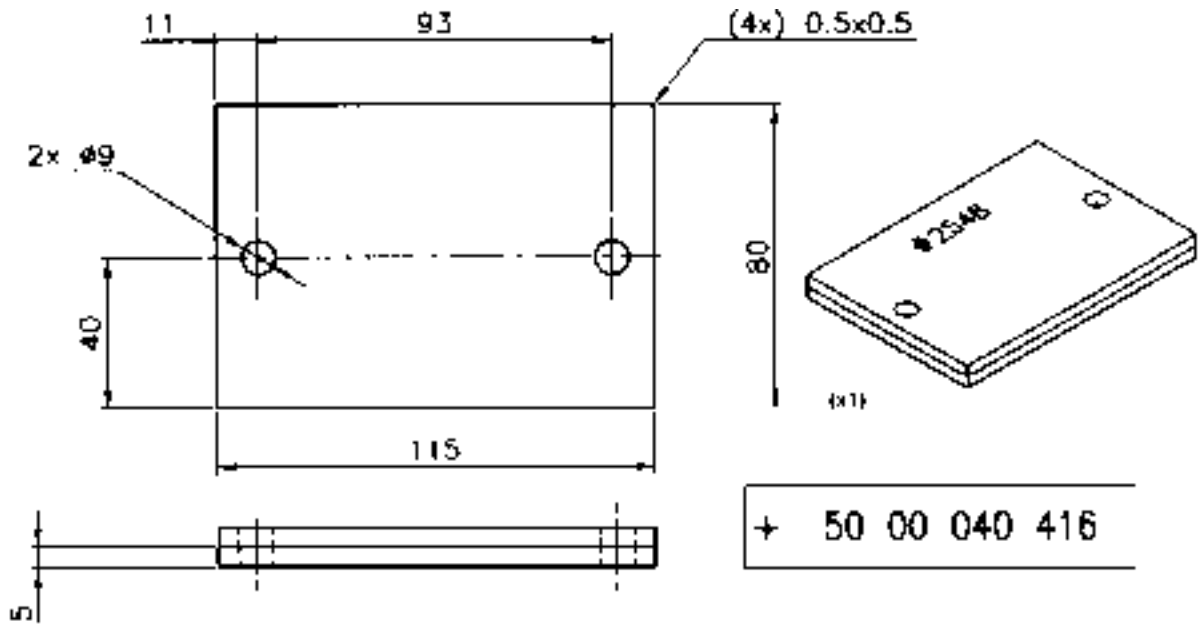

FL 2548

$\varnothing D$	$\varnothing d$	L
36	28	200
40	32	200
50	40	200
56	40	200
63	53	250
75	63	250
80	67	250
85	70	250
90	75	250
95	80	250
100	85	250

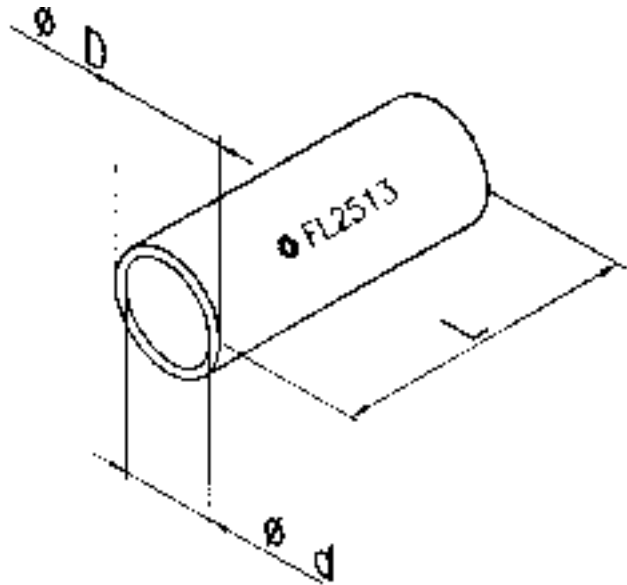

FL 2513

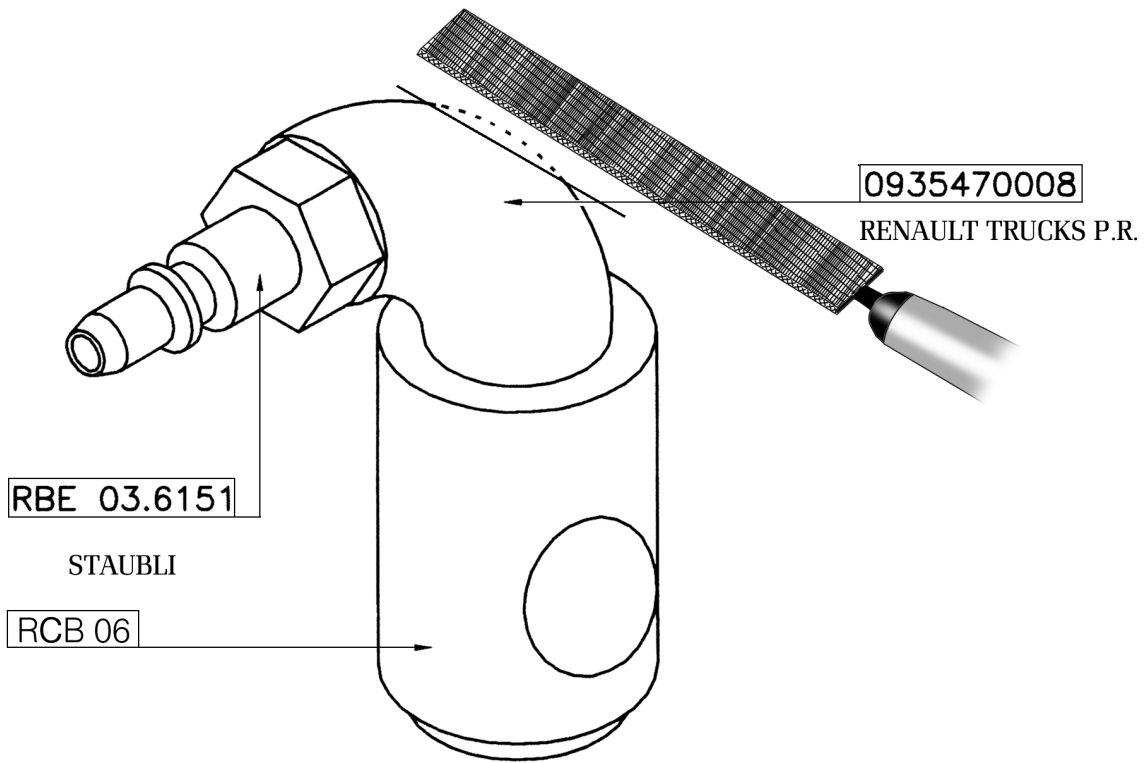

FL 2648

LIST OF CONSUMABLES

Automotive reference	Industrial reference
FRENETANCH 242	THREAD LOCKING COMPOUND 242
GRAISSE GRIPCOTT NF	GRIPCOTT NF GREASE
SPRAY MOLYCOTE GN PLUS DOW CORNING	SPRAY MOLYKOTE GN PLUS DOW CORNING
SCELBLOC 648	RETAINING COMPOUND 648
RECTIJOINT 518	GASKETING COMPOUND 518
SILMATE RTV 1473	SILMATE RTV 1473
OMNIFIT 50H	OMNIFIT 50H SEALING COMPOUND

STRIPPING AND MOUNTING ON STAND

Stand 1000

Mounting

RH side

- Disconnect flexible pipe (1).
- Remove pipes (2).
- Remove heat shield (4).
- Remove the filters/heat exchanger assembly (3).

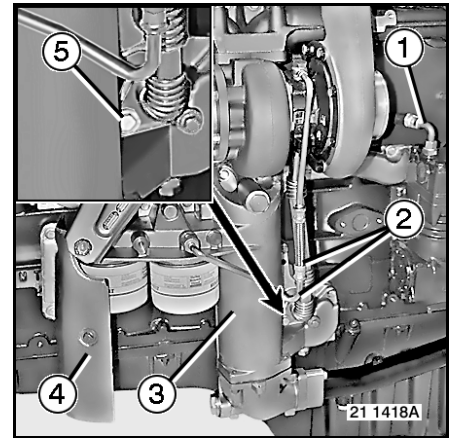

UPON ASSEMBLY OF THE BRACKET 2542, IT IS VITAL TO ENSURE THE LENGTH UNDER THE HEAD OF SCREW (5) WHICH MUST BE EQUAL TO 25 MM.

LH side

- Disconnect wiring harness (2).
- Remove setscrew (3).
- Remove setscrew (1).
- Tighten nuts (4).
- Remove the ECU / cooler assembly (7).
- Remove setscrew (6).

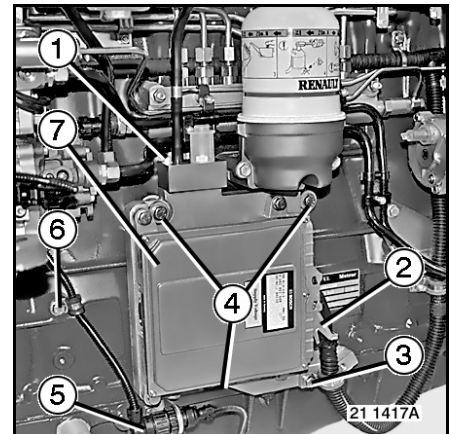

RH side

- Install tool 2542.

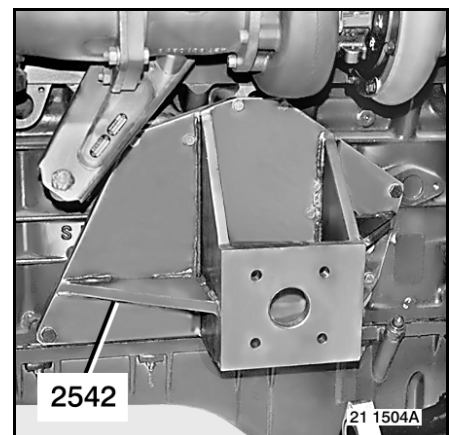

LH side

Install tool 2542.

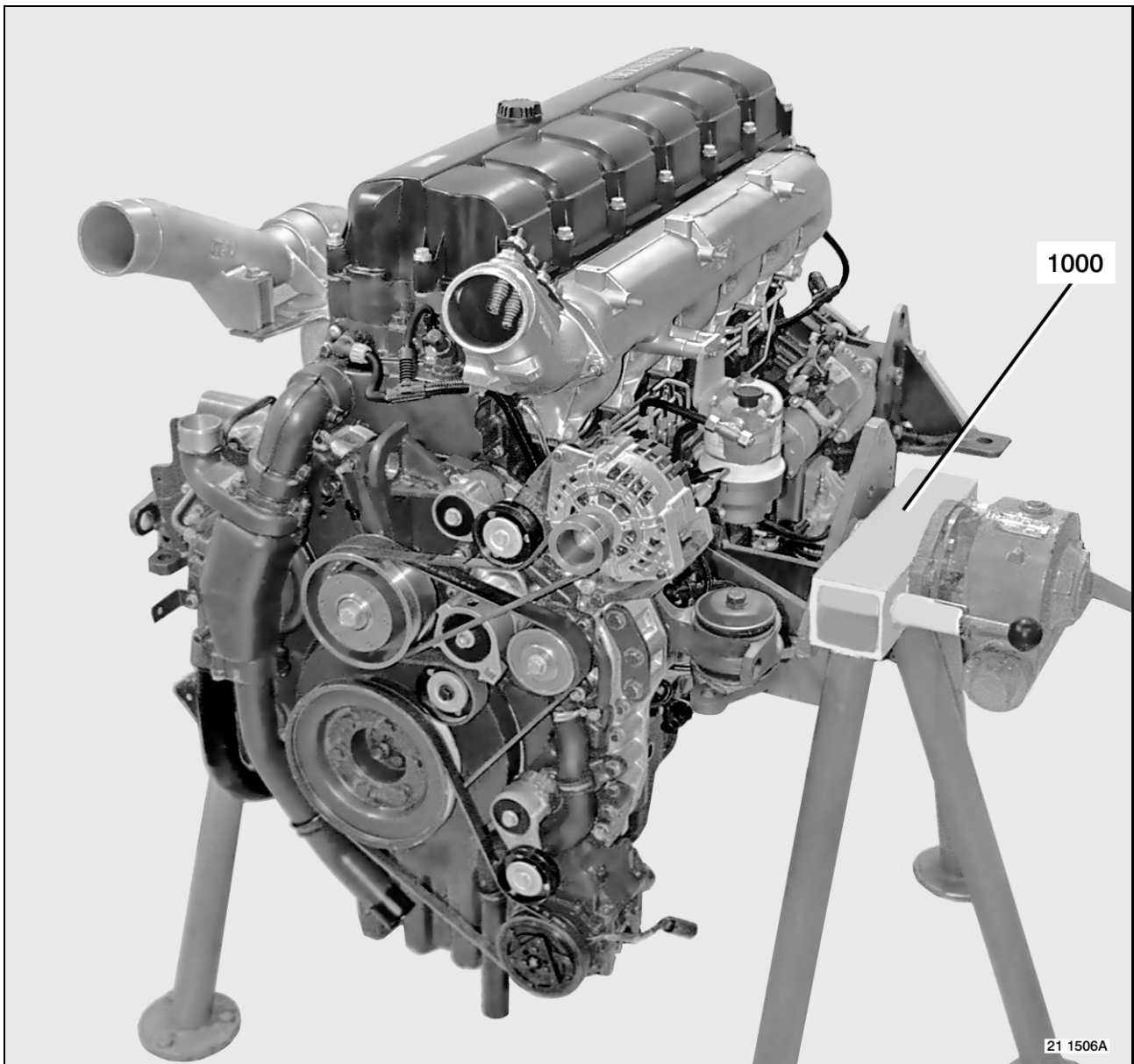
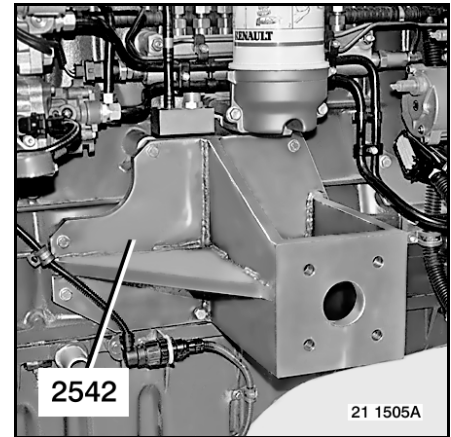

Fasten the engine to stand N°1000.

Removal

Install O-rings (A).

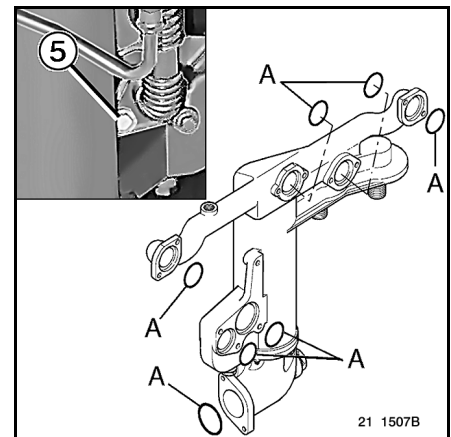

UPON ASSEMBLY, IT IS VITAL TO ENSURE THE LENGTH UNDER THE HEAD OF SCREW (5) WHICH MUST BE EQUAL TO 25 MM.

ENSURE A TIGHT SEAL WITH A SEALING PRODUCT FRENETANCH 242.

For the rest of the fitting operations, proceed in the reverse sequence to removal.

Tighten to torque.

See page B-2-2

Belt tensioner

Removal

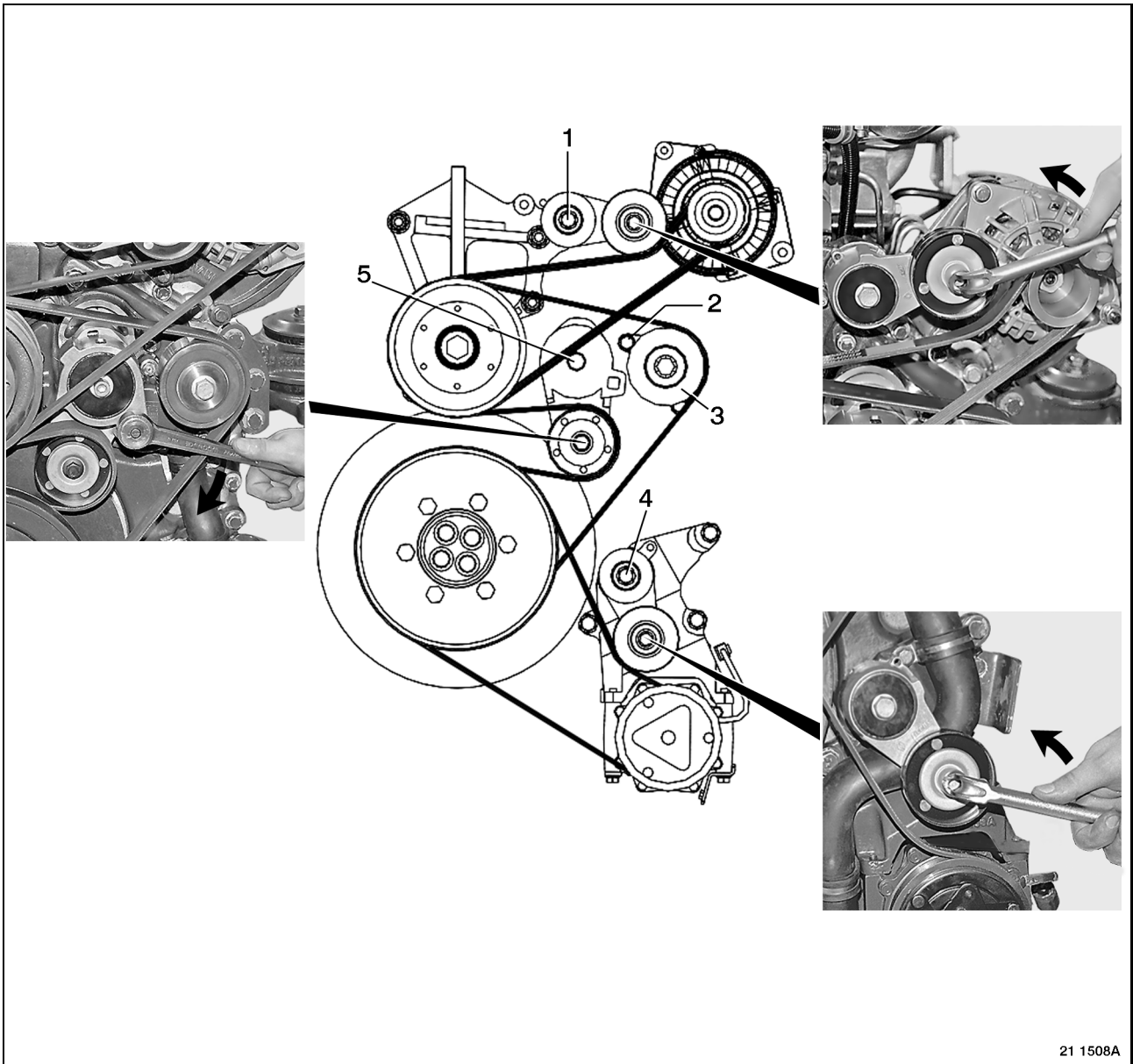

21 1508A

- Compress the tensioner rollers to disengage the drive belts.
- Remove drive belts.
- Tighten nuts **(1 - 4 - 5)**.
- Remove the tensioner rollers.
- Remove setscrew **(2)**.
- Remove jockey pulley **(3)**.

Fitting

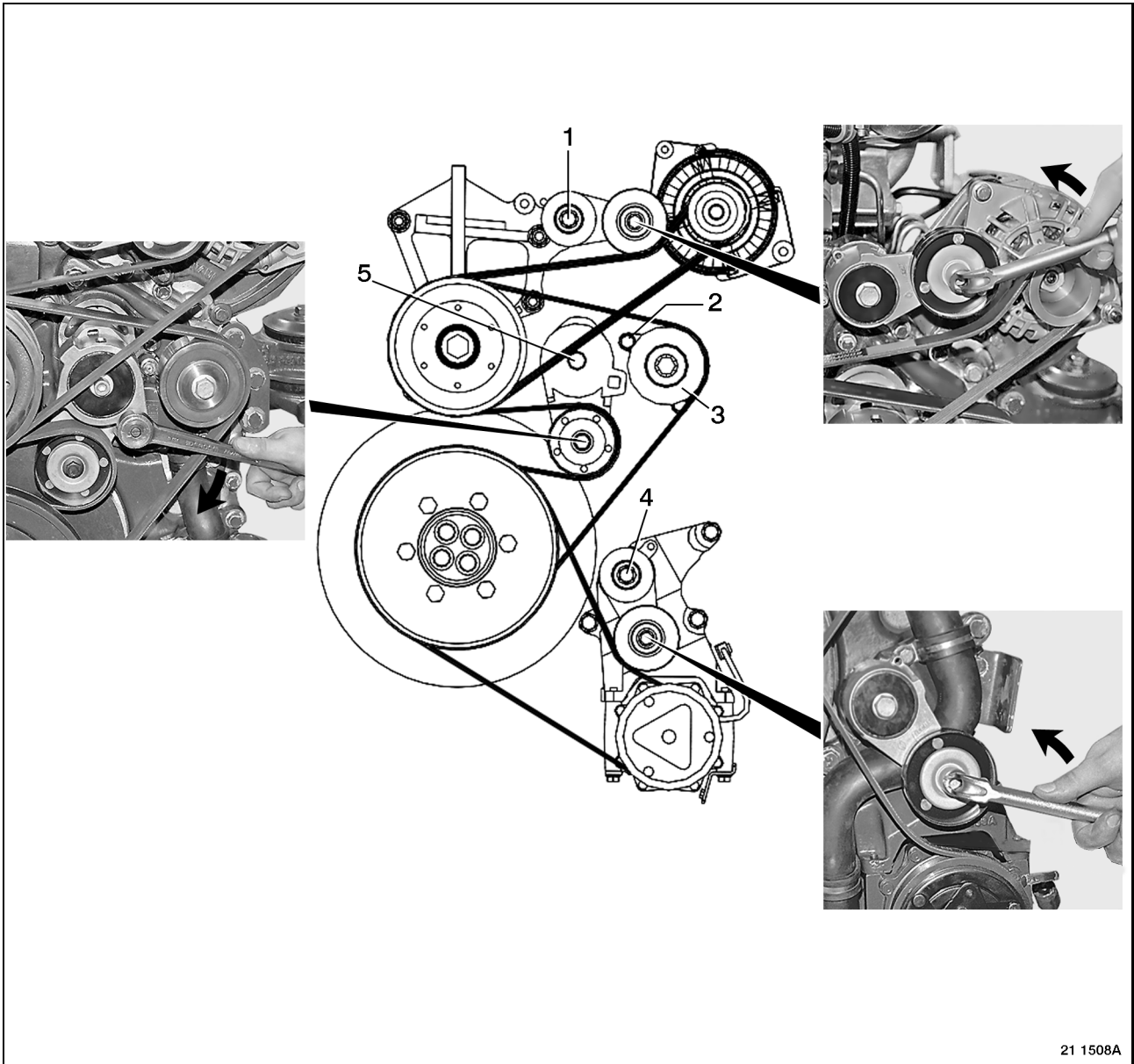

21 1508A

For fitting, proceed in the reverse sequence to removal.

Fit setscrew **(5)**.

Ensure a tight seal with a threadlocking and sealing product **FRENETANCH 242**.

Tighten to torque.

See page **B-2-4**

Compressor (air conditioner)

Removal

Remove compressor.
Remove the bracket.

Fitting

For fitting, proceed in the reverse sequence to removal.
Tighten to torque.

See page B-2-3

Fit support.

Start bolts (1 - 2 - 3) at a torque of 6 Nm.

Tighten nut (4) to torque.

Tighten bolts (1 - 2 - 3) to torque.

See page B-2-3

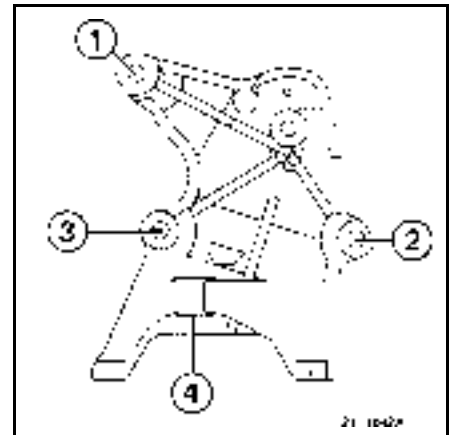

Fit the air compressor.

In the indicated sequence

Tighten to torque.

See page B-2-2

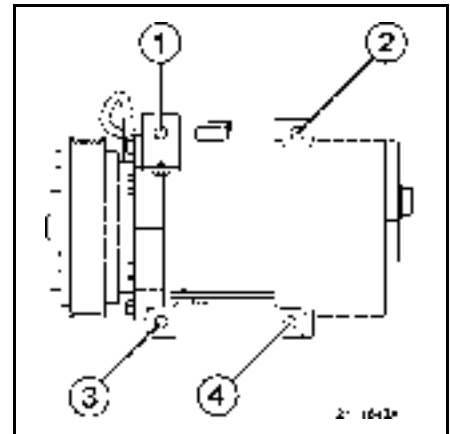

Setscrew (2) is a special screw that serves as guide. Replace it only with an identical screw.

Alternator

Removal

Remove alternator.
Remove the bracket.

Fitting

Fit support.
Start nuts (1 - 2 - 3 - 4) at a torque of **6 Nm**.
Tighten bolts (5 - 6) to torque.
Tighten nuts (1 - 2 - 3 - 4) to torque.
See page B-2-3

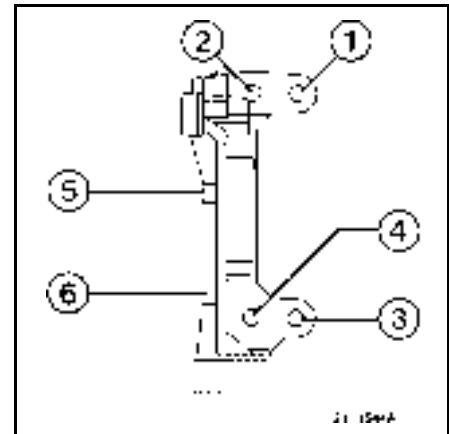

Fan control

Removal

Remove the fan control.

Fitting

For fitting, proceed in the reverse sequence to removal.
Tighten to torque.

See page B-2-5

Damper

Removal

Remove the damper.

Fitting

For fitting, proceed in the reverse sequence to removal.
Tighten to torque.

See page F-11

Disassembly

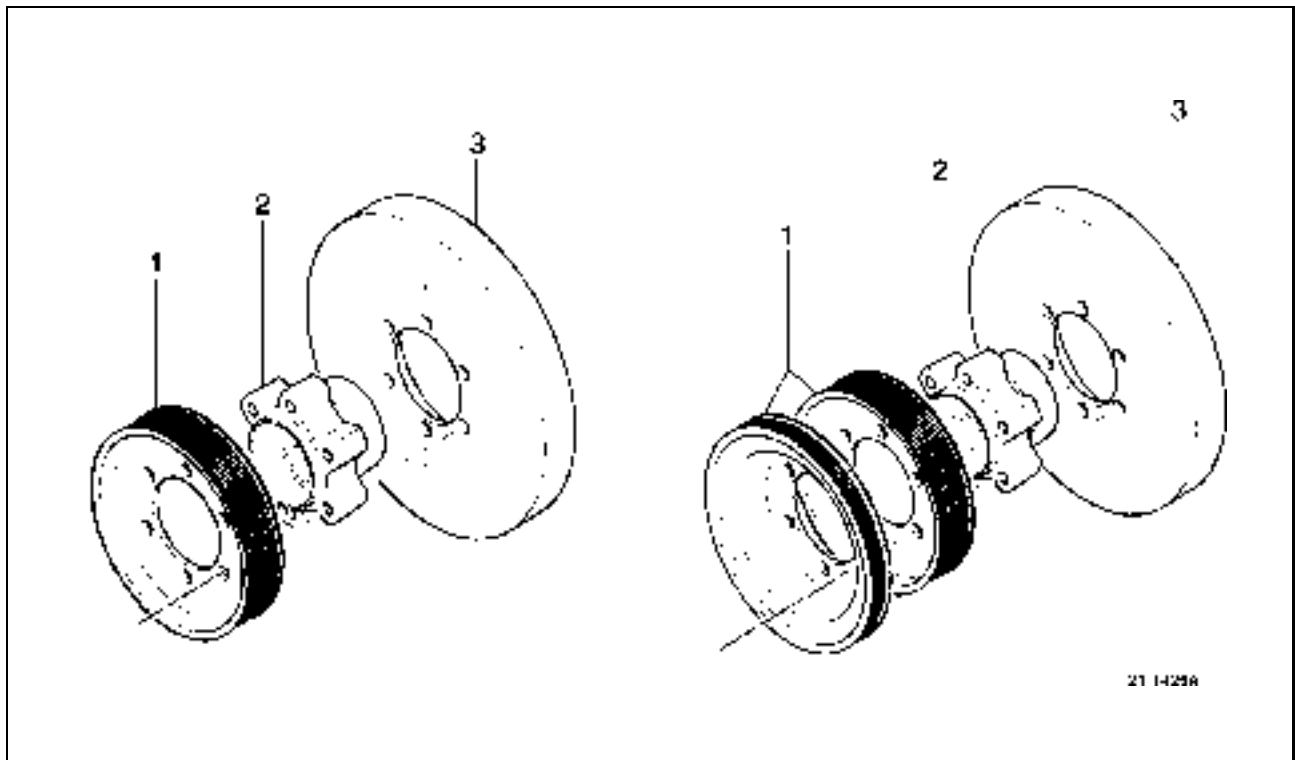

Depending on the assembly.
Separate hub (2) from damper (3).
Remove pulley (1).

Inspection

Check for the absence of:

- knock marks and bellmouthing of fixing holes;
- any cracks;
- points of impact;
- incorrect crimping on the outer part (there should be a regular thickness of 3 mm);
- distortion on the outer part;
- convexity;
- noise when shaking the damper.

Remove the paint at 4 points on both sides and measure the thickness of the damper. The deviation between the check points should be less than 0.25 mm.

If any one of the above defects is noted, replace the damper.

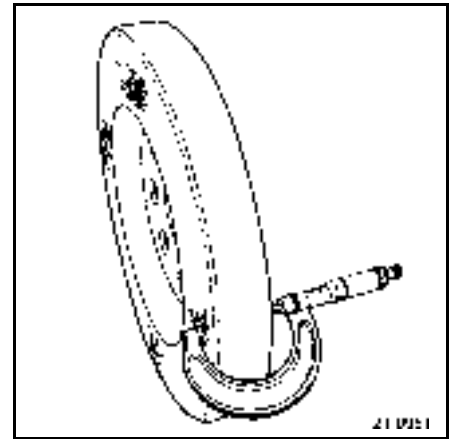

It is essential to clean the damper prior to assembly.

Assembly

The item numbers indicated in the text refer to the drawing on page D-6-1.

Assemble hub **(2)** to damper **(3)**.

Fit setscrews.

In the indicated sequence

Tighten to torque.

See page B-2-3

Assemble the pulley **(1)**.

Fit setscrews.

Tighten to torque.

See page B-2-3

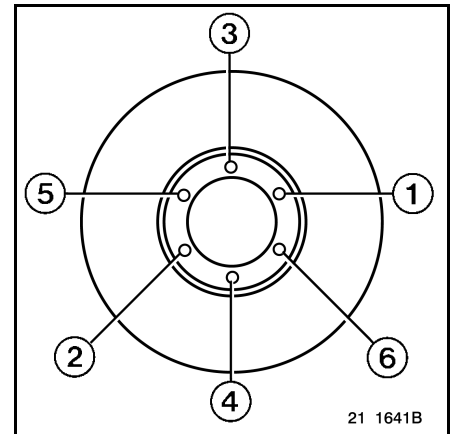

Starter

Removal

Remove the starter motor.

Fitting

For fitting, proceed in the reverse sequence to removal.
Tighten to torque.

See page B-2-2

Engine brackets

Removal

Remove the brackets.

Fitting

For fitting, proceed in the reverse sequence to removal.
Tighten to torque.

See page B-2-2

CYLINDER HEAD

Removal

Cylinder head exploded view

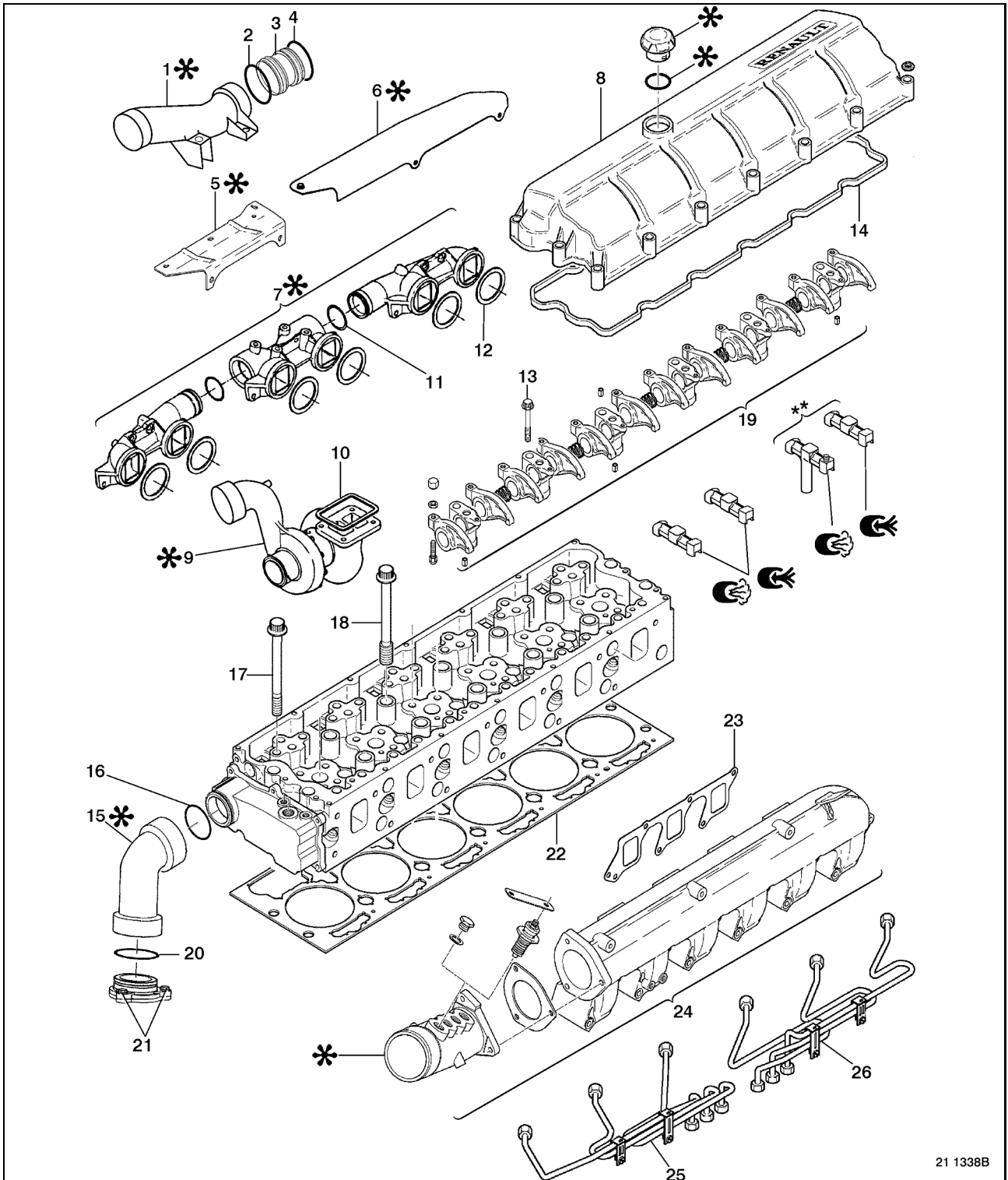

21 1338B

** With Jake brake

Removal of cylinder head

The item numbers indicated in the text refer to the drawing on page E-1-2.

Remove the cylinder head cover (8).

Remove the Jake engine-brake unit*.

See page O-3

Disconnect the wiring harness from the injectors.

Remove the wiring harness bracket.

Remove sensor (C).

Remove setscrew (A) so as to withdraw grommet (B) and the wiring harness.

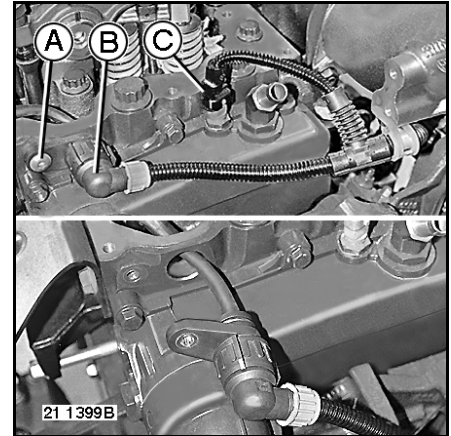

Remove sensor (A).

Remove union (B).

Remove the clamp and clip (C).

Withdraw pipe (1).

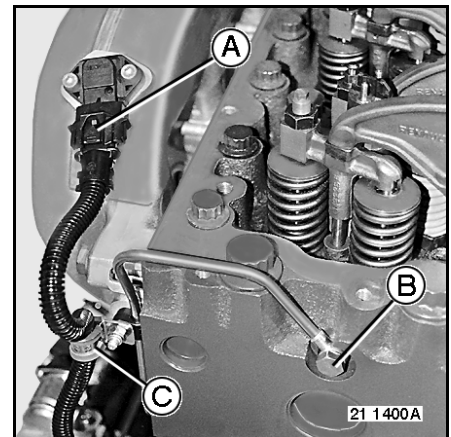

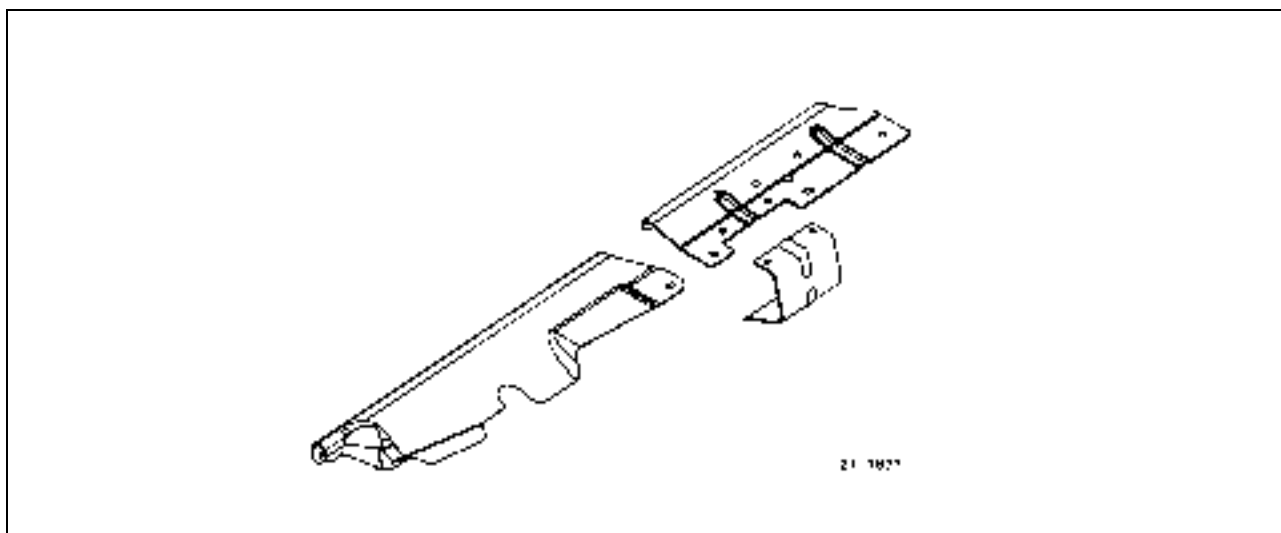
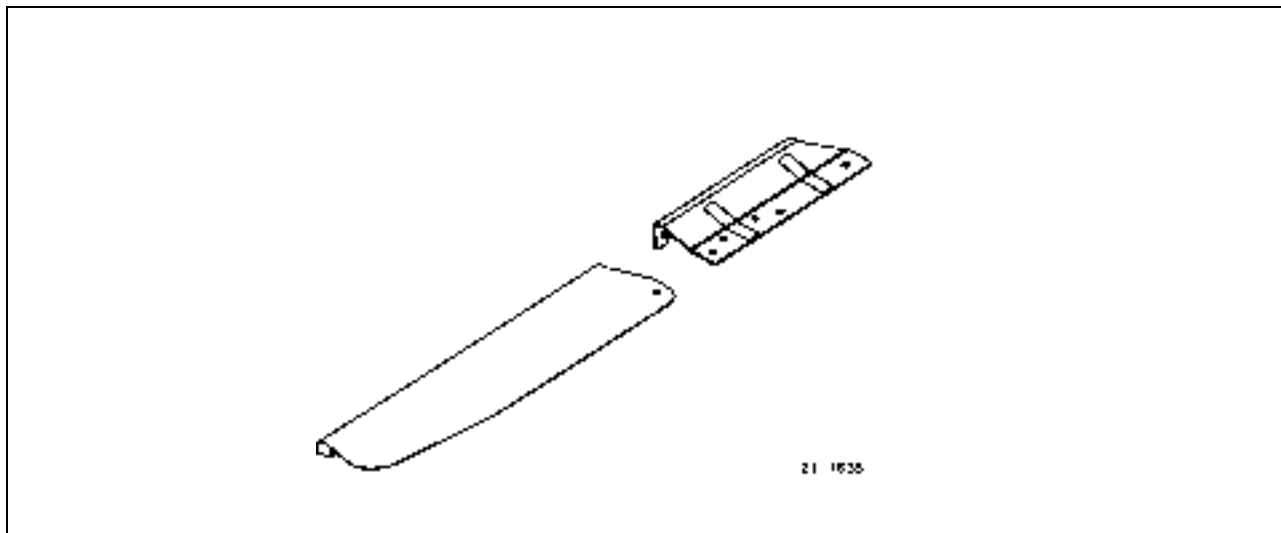

Remove heat shields **(5 - 6)** *.

Remove the angle-brackets.

Remove the turbocharger **(9)**.

Remove exhaust manifold **(7)**.

Tighten nuts **(21)**.

Withdraw pipe **(15)**.

Remove inlet manifold **(24)**.

Remove high pressure pipe gallery **(25 - 26)**.

Blank off the ports.

Tighten nuts **(13)**.

Remove the rocker assembly **(19)**.

Withdraw the push-rods.

Classify the parts in order.

Tighten nuts **(17 - 18)**.
Remove the cylinder head.
Withdraw cylinder head gasket **(22)**.

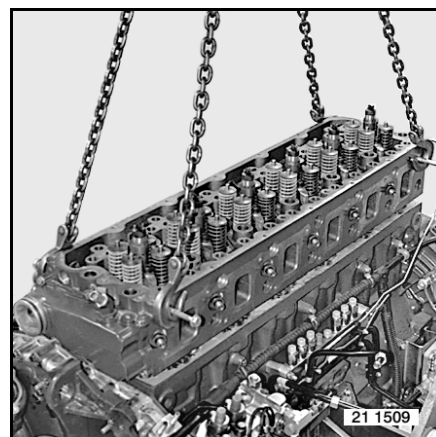

Immobilize the liners.
Use tool **1462**.

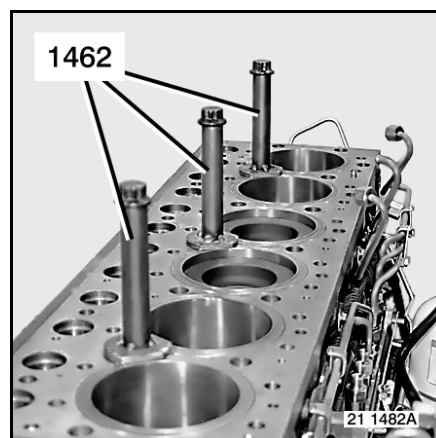

Fitting

Fitting of cylinder head

The item numbers indicated in the text refer to the drawing on page E-1-2.

Withdraw tool **1462**.

Check for the presence of locating dowels.

Use **2** headless screws (**A**) diameter: **14 mm**, length: **170 mm**.

Install cylinder head gasket (**22**).

Fit the cylinder head.

Tighten nuts (**A**).

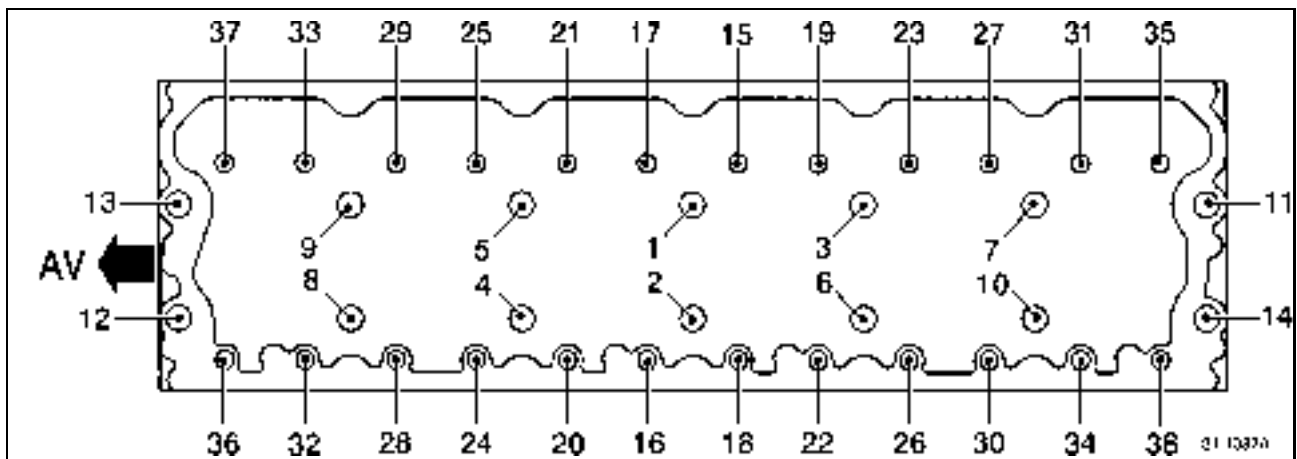
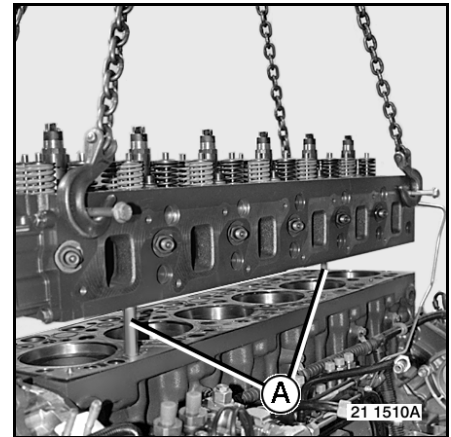

Fit setscrews (**17 - 18**).

In the indicated sequence

Tighten in 4 phases:

- 1st phase: bolt dia. 20 = **200 Nm**
- 2nd phase: bolt dia. 14 (**5010 295 320**) = **100 Nm**
- 2nd phase: bolt dia. 14 (**5010 550 554**) = **120 Nm**
- 3rd phase: bolt dia. 20, loosen then retighten one-by-one = **100 ± 10 Nm + 180° ± 6°**
- 4th phase: bolt dia. 14 (**5010 295 320**), loosen then retighten one-by-one = **60 ± 6 Nm + 100° ± 6°**
- 4th phase: bolt dia. 14 (**5010 550 554**), loosen then retighten one-by-one = **80 ± 6 Nm + 100° ± 6°**

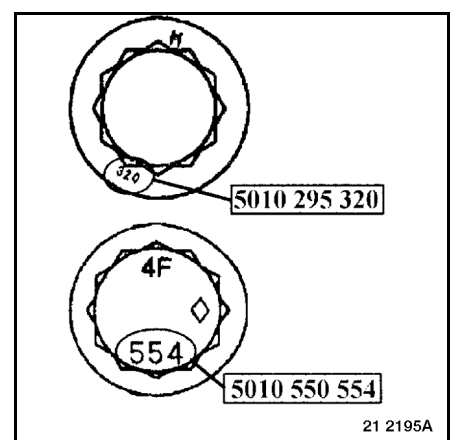

It is forbidden to subsequently retighten after application of this method.

Lubrication of setbolts:

- **New setbolts:** These pre-lubricated bolts do not require any lubrication.
- **Re-used setbolts:** As early as the second fitment, lubricate the screw-thread under the head with **SPRAY MOLYCOTE GN PLUS DOW CORNING.**

Use tool **2322 + 9777**

Fitting of valve yokes

See page E-2-3

Fitting of rocker shaft

See page E-2-4

Adjustment of valve yokes

See page E-2-4

Adjustment of rocker arms

See page E-2-5

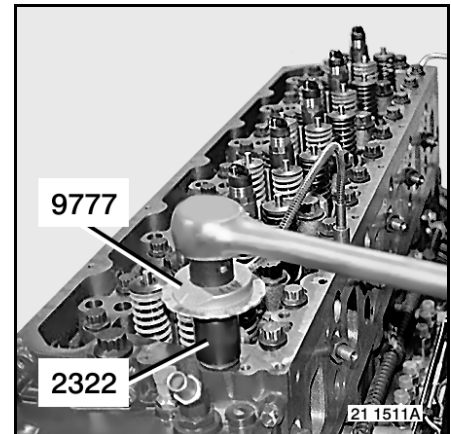

Connect up sensor **(C)**.

Install O-ring **(D)**.

Install grommet **(B)** and the wiring harness.

Fit setscrew **(A)**.

Fit the wiring harness bracket.

Connect the wiring harness to the injectors.

Tighten to torque.

See page B-2-6

Fit the Jake engine-brake unit.

See page O-3

Fitting the cylinder head cover

See page E-2-5

Assemble the high pressure pipe lines **(25 - 26)**.

Tighten to torque.

See page B-2-6

Install O-rings **(16 - 20)**.

Assemble sleeve.

Fit the pipe **(15)**.

Fit setscrews **(21)**.

Tighten to torque.

See page B-2-2

Fitting the inlet manifold

See page E-2-6

Connect up sensor **(A)**.

Assemble the clamp and clip **(C)**.

Change the copper joints.

Screw the connector **(B)**.

Tighten to torque.

See page B-2-6

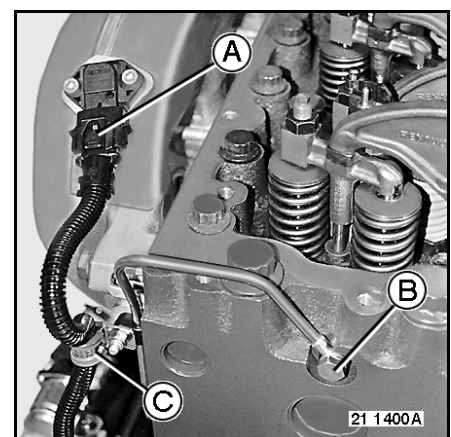
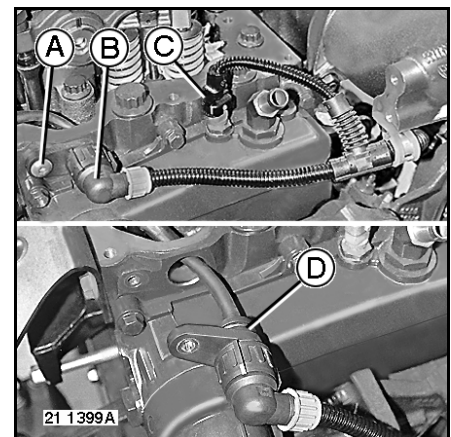

Fitting the exhaust manifold**See page E-2-6**

Install seal (10).

Assemble turbocharger (9).

Tighten to torque.

See page B-2-5

Assemble heat shields (5 - 6).

See page E-1-4

Proceed in the reverse sequence to removal.

Tighten to torque.

See page B-2-3

Install O-rings (2 - 4).

Assemble sleeve (3).

Fit the pipe (1).

Tighten to torque.

See page B-2-2**Fitting of valve yokes**

Apply oil.

Fit the U-bolts.

Ensure the position

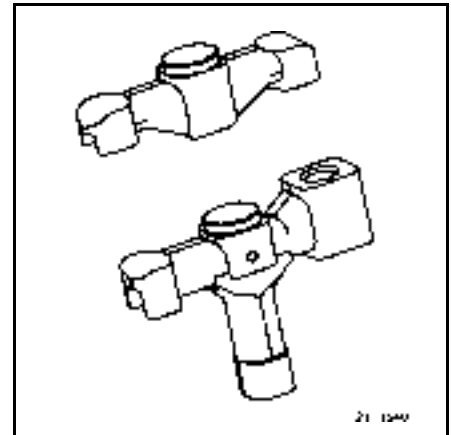
**Only for: dCi 11 B43**

Apply oil.

Fit the U-bolts.

Ensure the position

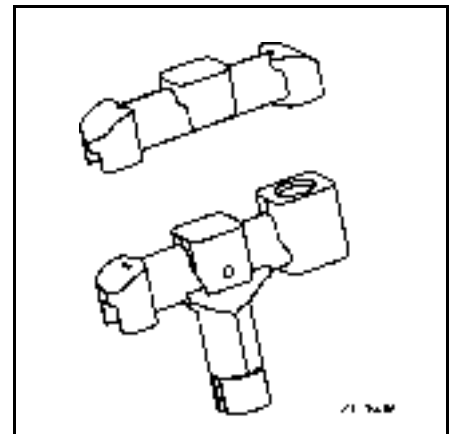

**Do not fit these yokes on other engines.
Risk of engine damage.**

Fitting of rocker shaft

Apply oil.

Put the push-rods into place.

Ensure the position

Check for the presence of locating dowels.

Remove the rocker assembly.

For engines fitted with Jake brake: provisionally use spacers (A) for fastening the mechanisms.

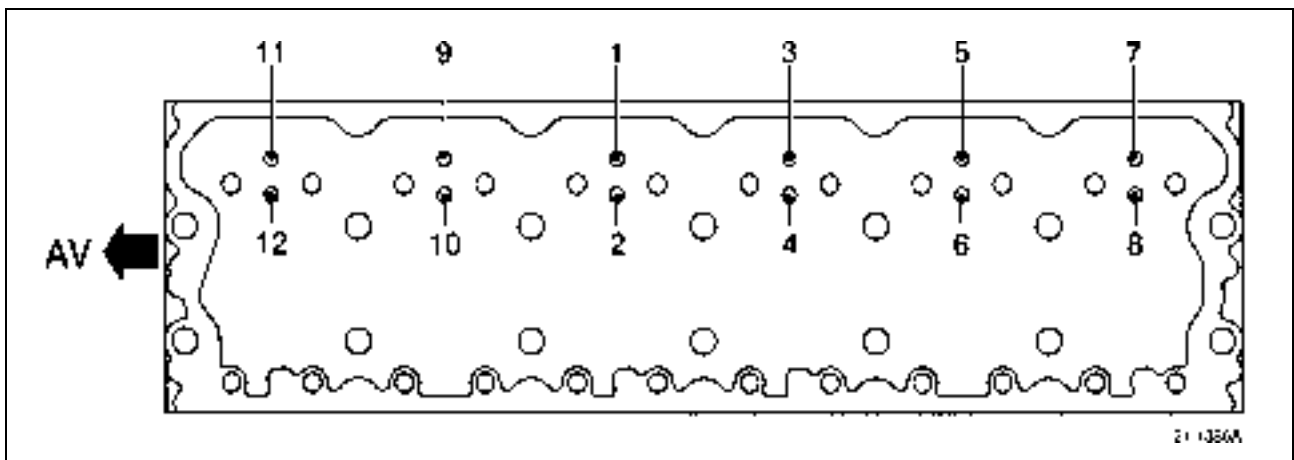
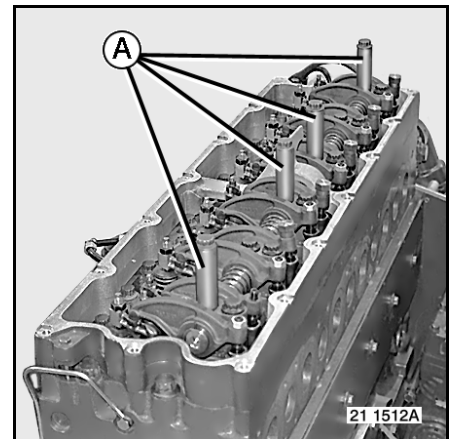

In the indicated sequence

Tighten to torque:

- Rocker shaft setbolts: $40 \pm 4 \text{ Nm} + 90 \pm 6^\circ$
- Jake brake mechanisms to rocker arm assembly setbolts: $60 \pm 6 \text{ Nm} + 120 \pm 6^\circ$.

Lubrication of setbolts:

- **New setbolts:** These pre-lubricated bolts do not require any lubrication.
- **Re-used setbolts:** As early as the second fitment, lubricate the screw-thread under the head with **SPRAY MOLYCOTE GN PLUS DOW CORNING**.

Adjustment of valve yokes

To be done each time before adjusting the rocker arms:

- With the cylinder at the compression stroke (valves closed), check for the presence of clearance between the rocker arm and the valve yoke.
- Loosen locknut (B).
- Free adjusting screw (A).
- With the rocker arm in abutment on the yoke, bring adjusting screw (A) into contact with the valve (without exerting any force).
- Tighten locknut (B) to torque while holding the adjusting screw (A).

See page B-2-3

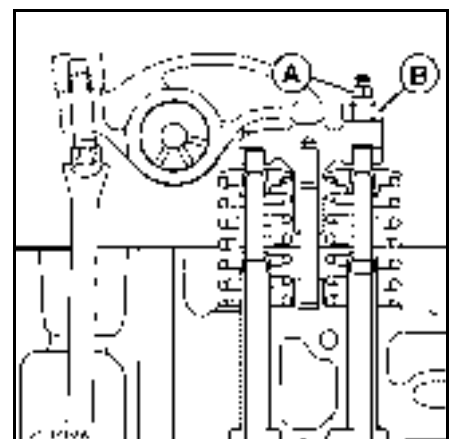

Adjustment of rocker arms

Adjustment values: engine cold:

- Exhaust: **0.70 mm.**
- Inlet: **0.40 mm.**

Valves in balance (end of exhaust, start of induction in cylinder N°)	Adjust the clearances of the valves in cylinder N°
6	1
2	5
4	3
1	6
5	2
3	4

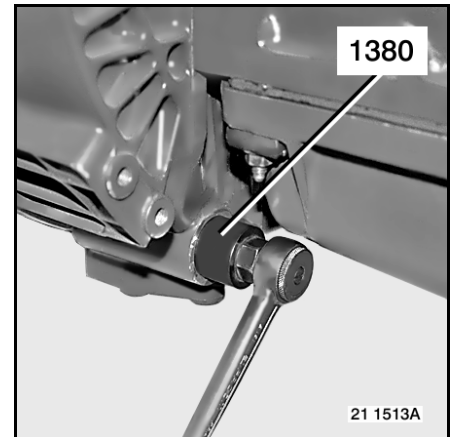

Use tool **1380**.

Tighten the locknuts to torque.

See page **B-2-3**

Fitting the cylinder head cover

The item numbers indicated in the text refer to the drawing on page E-1-2.

Install seal (**14**).

Fit rocker cover (**8**).

Fit the setbolts fitted with rubber sandwich mountings.

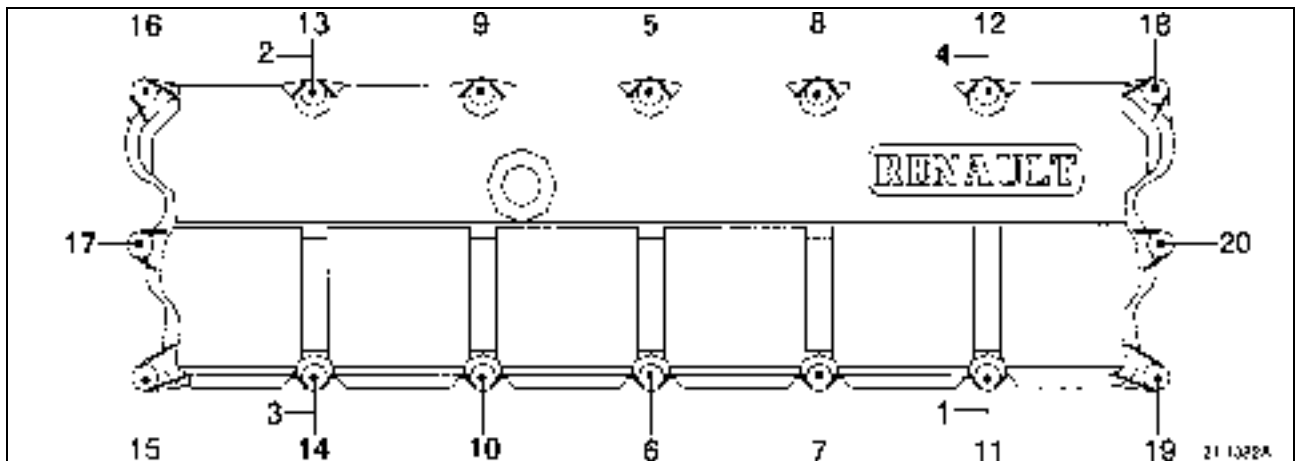

Tighten to torque.

- **1**: preliminary tighten at **2 Nm**.
- **2**: tighten at **20 ± 4 Nm**.

Fitting the inlet manifold

The item numbers indicated in the text refer to the drawing on page E-1-2.

Install seals (23).

Fit intake manifold.

Fit setscrews.

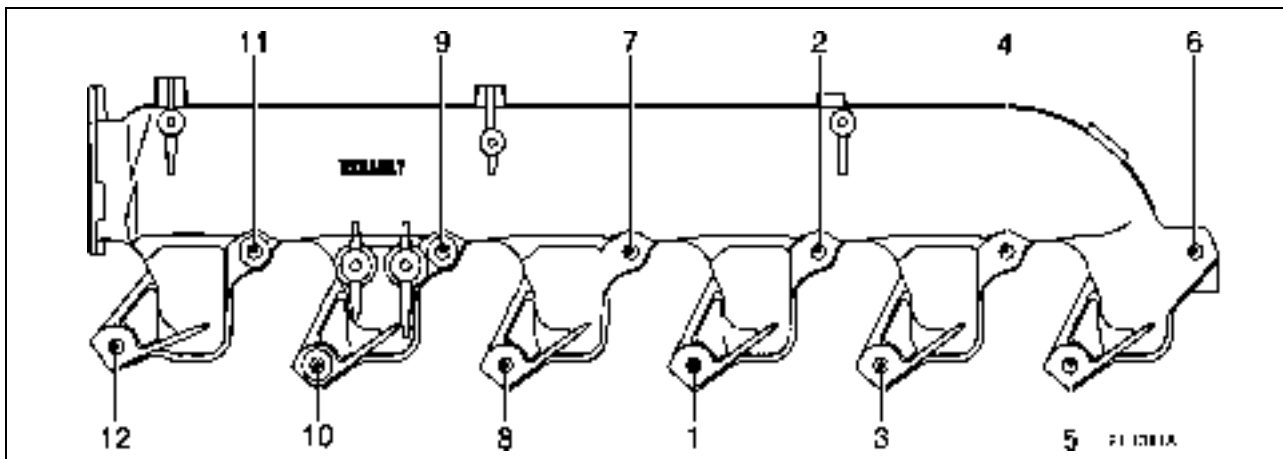

In the indicated sequence

Tighten to torque.

- 1: preliminary tighten at **20 Nm**.
- 2: tighten at **60 ± 12 Nm**.

Fitting the exhaust manifold (B43)

The item numbers indicated in the text refer to the drawing on page E-1-2.

Assemble rings (11).

Install seals (12).

Fit exhaust manifold (7).

Fit setscrews.

Smear the screwthreads with **GRAISSE GRIPCOTT NF** copper grease

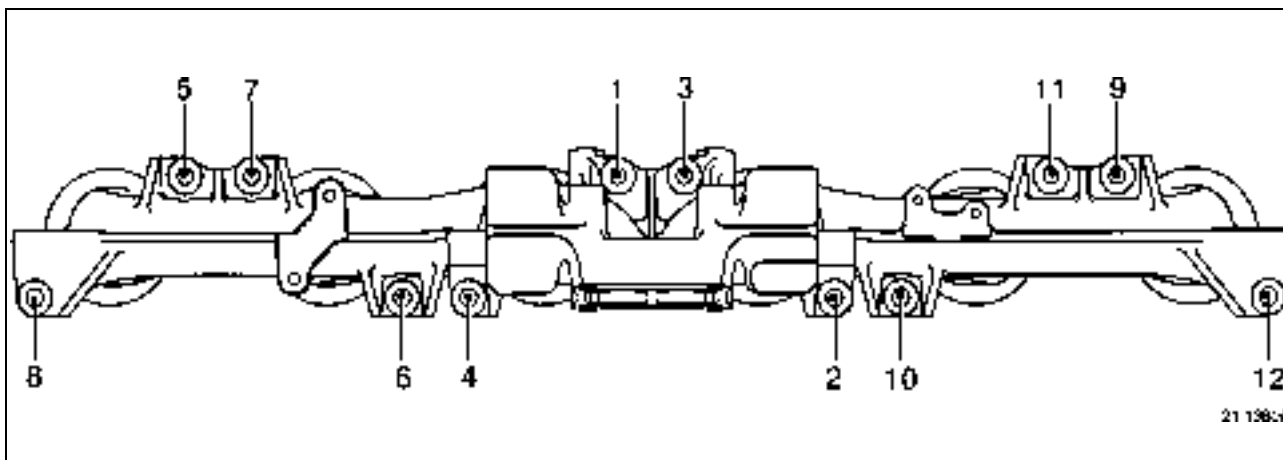

In the indicated sequence

Tighten to torque.

- 1: preliminary tighten at **20 Nm**.
- 2: tighten at **60 ± 12 Nm**.

Fitting the exhaust manifold (+ J01)

The item numbers indicated in the text refer to the drawing on page E-1-2.

Assemble rings (11).

Install seals (12).

Fit exhaust manifold (7).

Fit setscrews.

Smear the screwthreads with **GRAISSE GRIPCOTT NF** copper grease

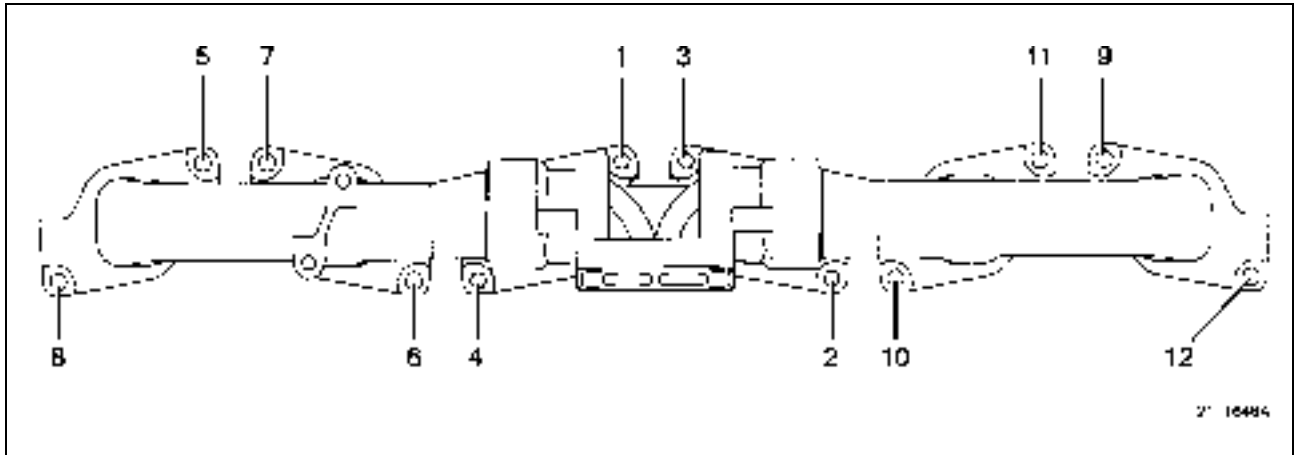

In the indicated sequence

Tighten to torque.

- 1 : preliminary tighten at **20 Nm**.
- 2 : tighten at **40 ± 8 Nm**.

Disassembly/inspection/assembly

Cylinder head detail

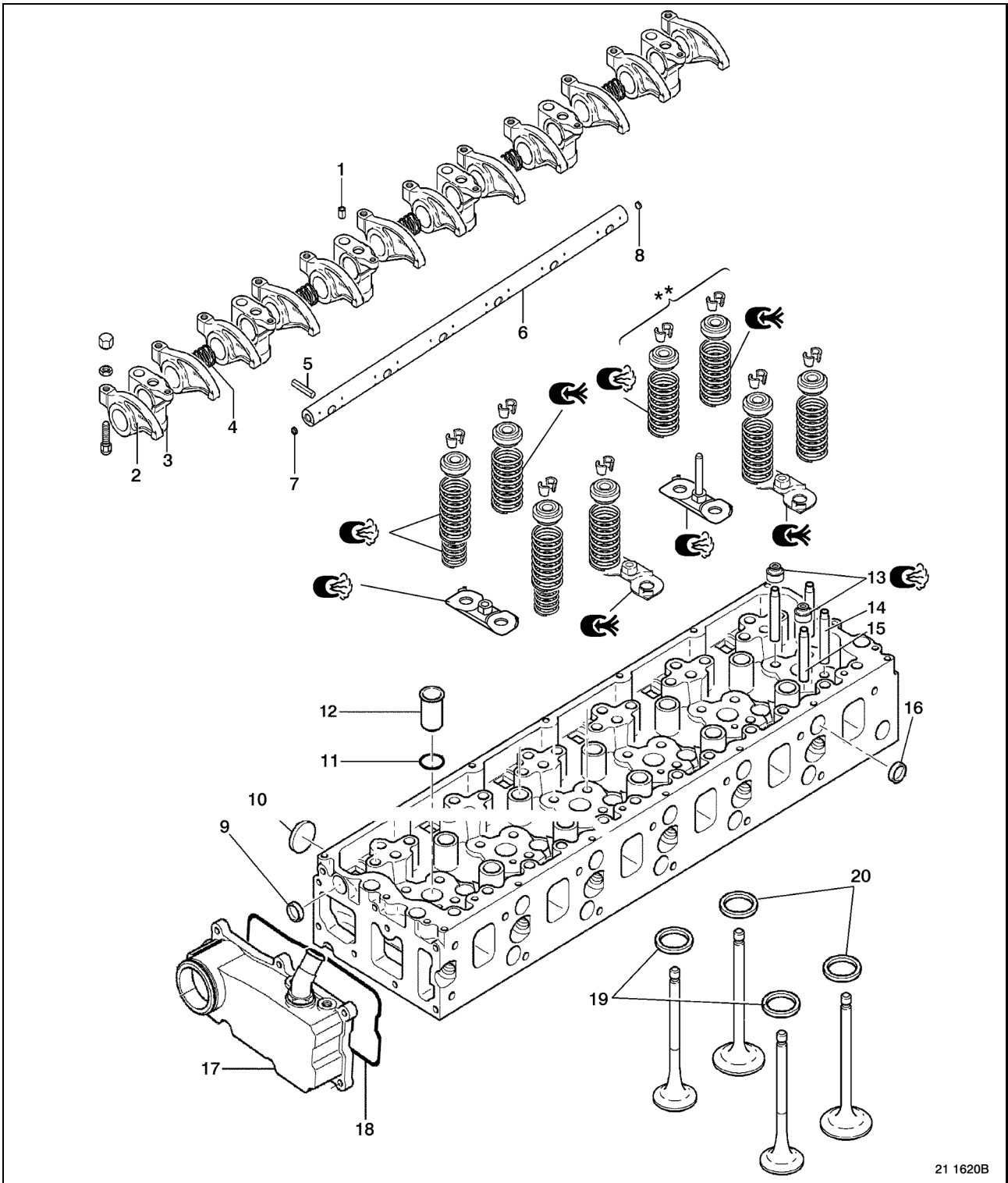

** With Jake brake

Disassembly

The item numbers indicated in the text refer to the drawing on page E-3-1.

Remove the nozzle-holders.

Take out seals.

See page J-2-10

Remove housing (17).

Take out O-ring (18).

Valves

Compress springs.

Use tool **9838**.

Save valve cotters.

Withdraw cups.

Take out springs.

Withdraw cups.

Remove the valves and arrange them in order.

Take out seals (13).

Valve guides

Classify the parts in order (14 - 15).

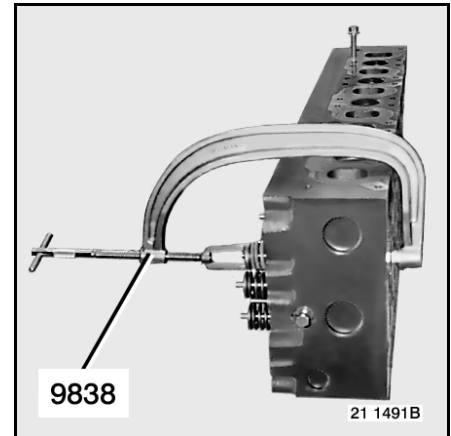

Valve seats

Weld an old valve or a washer to the seat.

Drive out valve seats (19 - 20).

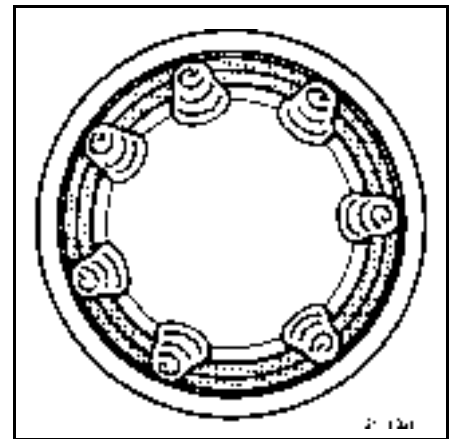

Injector sleeves

Tap to \varnothing 26 x 150 mm.

Withdraw body (12).

Use tool **1205**.

Take out O-ring (11).

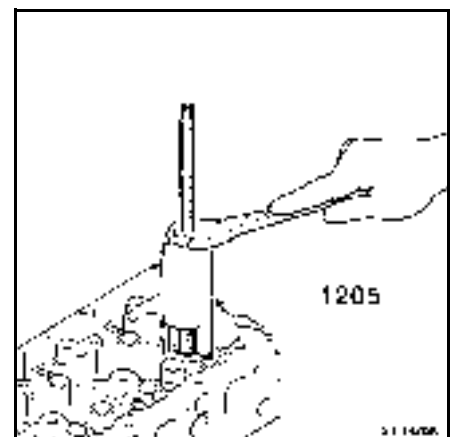

The injector body is to be replaced when the cylinder head is removed.

Clean after the operation.

Cleaning

If necessary

To decarbonize, take out core plugs (9 - 10 - 16).

Rocker assemblies

Remove locating dowel (1).
 Remove pins (5).
 Save rocker arms (2).
 Withdraw pedestals (3).
 Take out springs (4).
 If necessary
 Classify the parts in order (7 - 8).

Inspection**See page B-3-1**

Check the mating surface.

Cylinder head seal

Test the cylinder head for leaks before commencing the overhaul. In a bath of hot water (80°C), air pressure 6 bars, check for the absence of air bubbles.
 Use tool 2549.

Valves

Check the calibration of the springs.
 Check the yokes and the yoke guides guide.

Valve guides

Check the radial clearance of the valves in their guides.

Valve seats

Check the valves set-back or protrusion.

Rocker assemblies

Check the rocker arm bore.
 Check the rocker shaft.

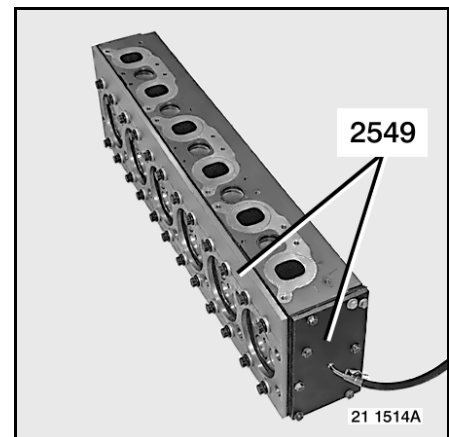
**Assembly / grinding**

The item numbers indicated in the text refer to the drawing on page E-3-1.

Fit core plugs (9 - 16).

Use tool 3016 + 2363 Ø 25 mm.

Fit core plugs (10).

Use tool 3016 + 2363 Ø 42 mm.

Use a sealing product "SCELBLOC 648".

Ensure a set-back $A = 1.5 \pm 0.5$.

Fire grooves

After grinding the cylinder head, the fire grooves must be machined.
 Ensure the dimensions.

See page B-3-2

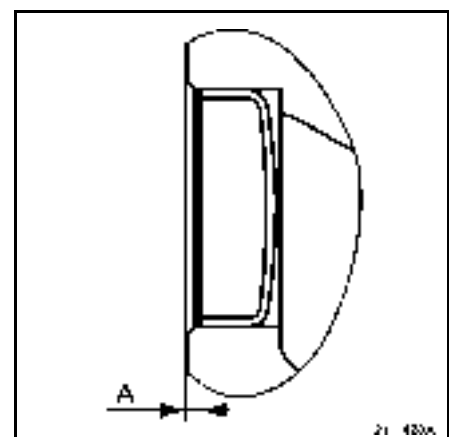

Injector sleeves

Apply tallow.
 Install O-ring (11).
 Insert the sleeve (12).
 Install tool 2556.
 Flange over at (A).
 Use tool 1220.

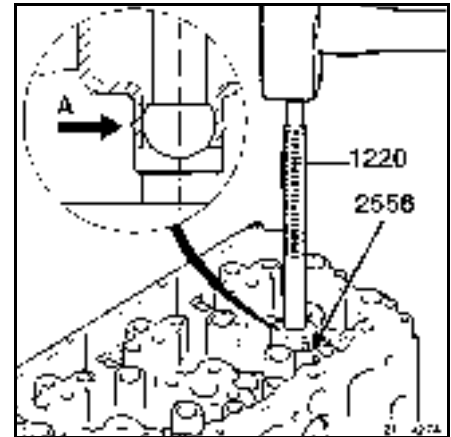

Withdraw tool 1220.
 Use tool 1205.
 Withdraw tool 2556.
 Test for leaks.
See page E-3-3

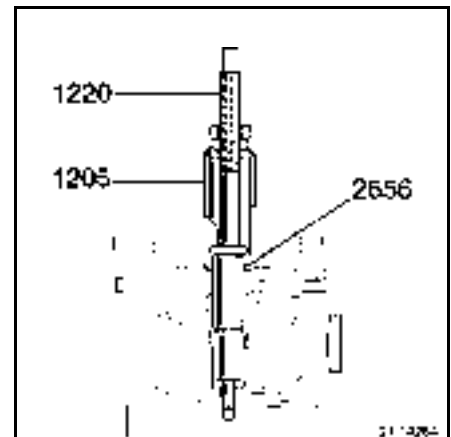
**Valve guides**

Apply tallow.
 Press fit inlet valve guides (14).
 Use tool 2539 on side A.
 Use a press.
 Press fit exhaust valve guides (15).
 Use tool 2539 on side B.
 Use a press.

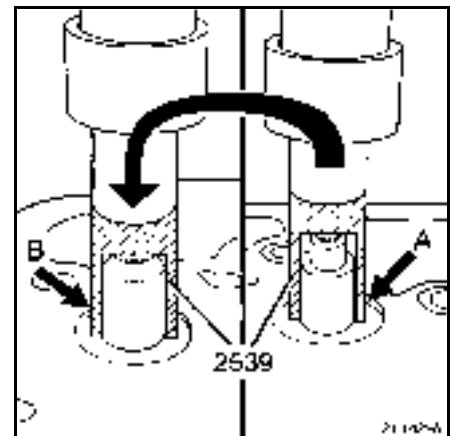

After replacing the valve guides, it is essential to grind the valve seats.
 As spare part, the valve guides are supplied with 7.6 mm inside diameter.
 They must be re-reamed after installation in the cylinder head.

See page B-3-1

Valve seats

Shrink parts in liquid nitrogen or for 12 hours in a deep freezer.

Assemble valve seats (19 - 20).

Use tool 1332.

Use a press.

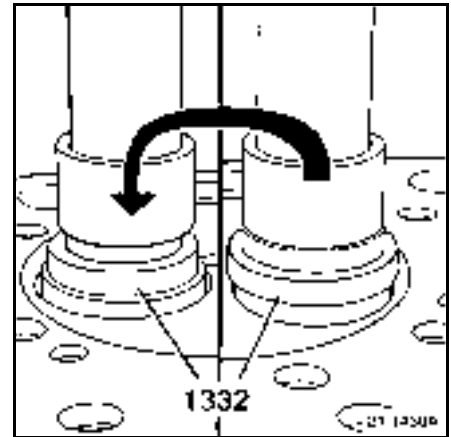
**Grinding valve seats**

Prior to grinding the valve seats, make sure the valve guides are in good condition. Replace them, if necessary.

Method:

The valve guides should serve to centre the tool.

Take into consideration the valves set-back values R to determine the amount of metal to be removed.

- Grind bearing surface **P** while ensuring angle **A**:
 - Inlet = 60°
 - Exhaust = 45°

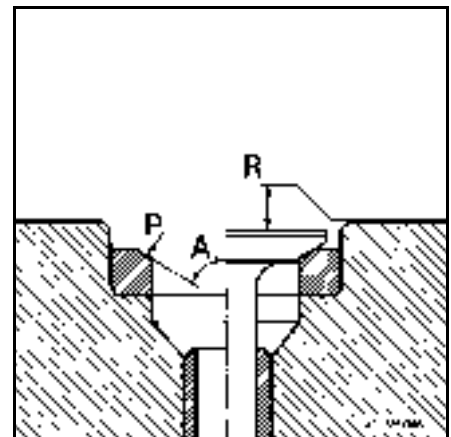

Depending on the tool used, the angles are datum located either in relation to the cylinder heat joint face or in relation to the valve centre-line.

Use tool 9732.

Valves

Do not grind the valves.

Do not lap the valves.

Assemble seals on exhaust guides.

Use a suitable tube.

Oil the valve stems and install the valves.

Fit cups.

Fit the springs.

Tension the springs.

Use tool 9838.

Fit valve cotters.

Injector nozzle-holders

Install the nozzle-holders.

See page J-2-10

Check the injector protrusion.

See page B-3-2

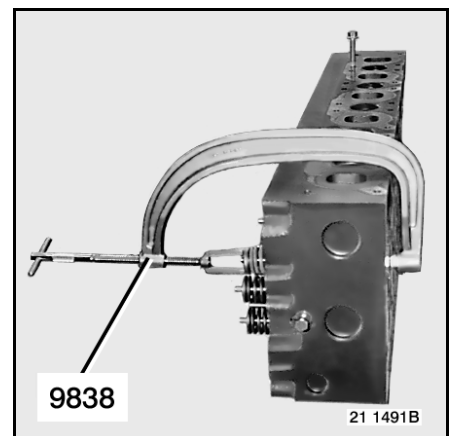

Rocker assemblies

Fit core plugs **(7 - 8)**.

Use a sealing product "**SCELBLOC 648**".

Use a suitable tube.

Apply oil.

Fit rocker arms **(2)**.

Assemble pedestals **(3)**.

Fit the springs **(4)**.

Ensure the position

Fit pins **(5)**.

Fit locating dowels **(1)**.

Install seal **(18)**.

Fit the casing **(17)**.

Fit setscrews.

Tighten to torque.

See page B-2-2

VALVE TIMING

Exploded view

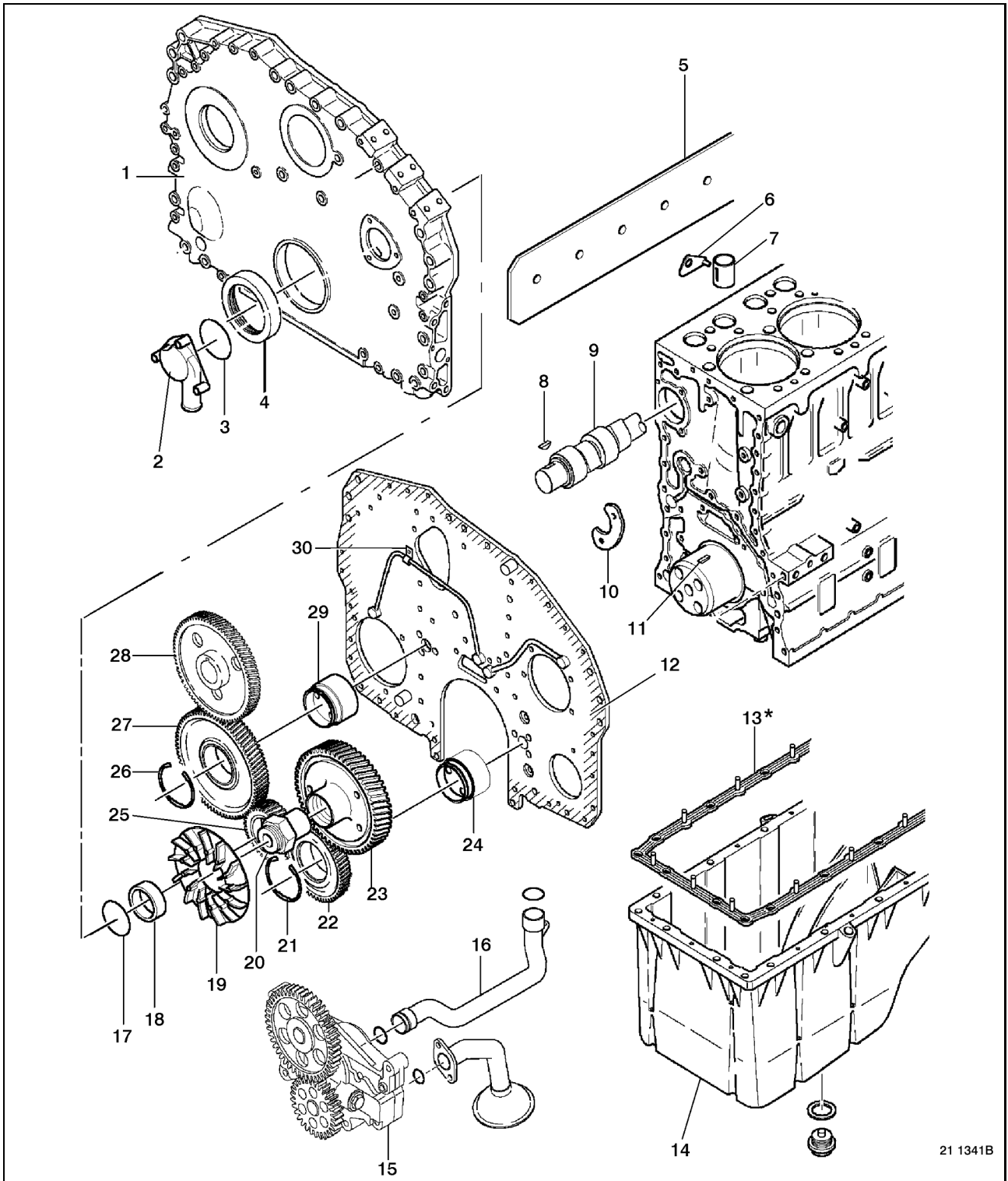

* for trucks.

Removal

The item numbers indicated in the text refer to the drawing on page F-2.

Tappets

Remove tappet cover (5).

Tighten nuts.

Withdraw the tappet retainers (6).

Withdraw tappets (7).

Classify the parts in order.

Damper

Remove damper.

Water pump

Remove the water pump.

Air compressor

Remove compressor.

Hydraulic pump

Remove hydraulic pump.

Oil sump

Remove the oil level sender.

Use tool 2537.

Remove oil sump (14).

Withdraw gasket (13).

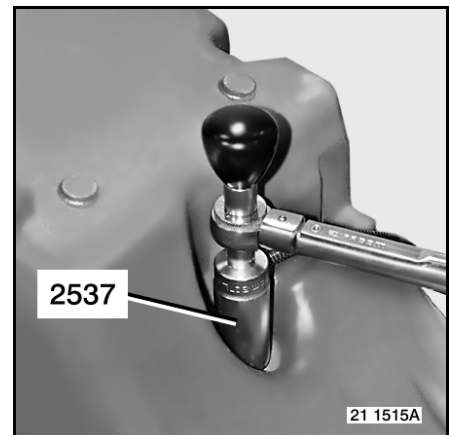
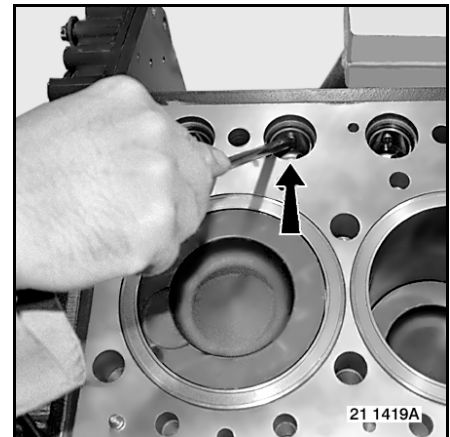

Timing case

Remove breather (2).

Remove timing case (1).

Withdraw seal ring (4).

For replacement only.

Withdraw deflector (A).

Use a press.

Use tool 3016 + 2363 Ø 68 mm.

High pressure pump

Remove the nut (20).

Extract pinion (23).

Remove the high-pressure pump.

See page J-2-13

Remove impeller (19).

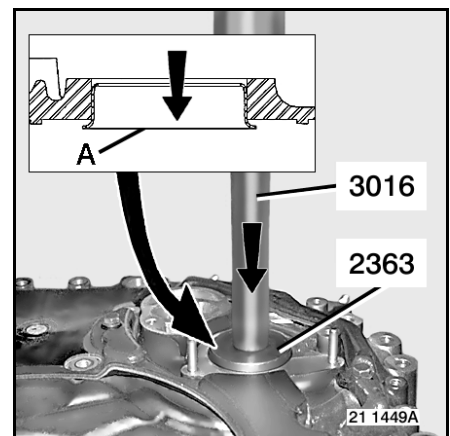

Idler gears

Remove the circlips (21 - 26).

Remove pinions (22 - 27).

Tighten nuts.

Remove hubs (24 - 29).

Camshaft

Take off stop (10).

Remove the camshaft assembly (9).

Crankshaft pinion

Take out O-ring (17).

Withdraw spacer (18).

Extract crankshaft pinion (25).

Remove key (11).

Oil pump

Remove pipe (16).

Remove the sensor.

Tighten nuts.

Withdraw the oil pump (15).

Front plate

Remove front plate (12).

Inspection**On the camshaft, inspect:**

- Coaxiality,
- Cam lift,
- Bearing surface diameter,
- Bushes.

Check the idler gears**On the tappets, inspect:**

- Diameter and housing.

Disassembly**Camshaft pinion**

For replacement only.

Extract pinion (28).

Use a press.

Remove key (8).

Camshaft bearing bush

For replacement only.

Withdraw bushes.

Use tool 1281 + 1282

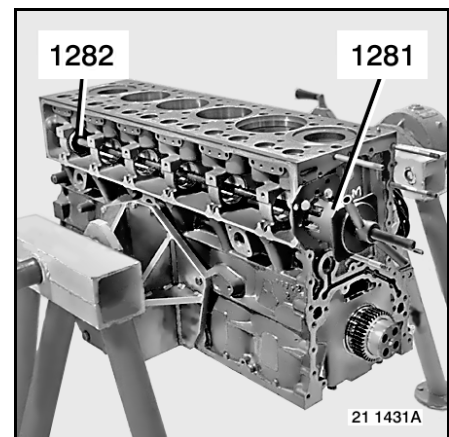

Air compressor pinion

In a vice.

Use a protective device (A).

Remove the nut.

Fit nuts.

Extract pinion.

Use tool **0843**.

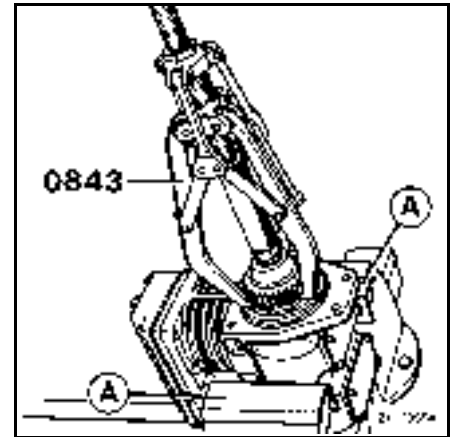
**Hydraulic pump pinion**

In a vice.

Use a protective device (A).

Remove the nut.

Fit nuts.

Extract pinion.

Use tool **0843**.

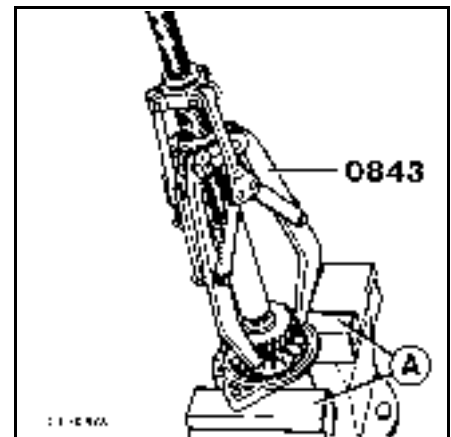
**Water pump**

See page I-3-2

Fan hub

See page I-2-2

Assembly**Camshaft bearing bush**

Fit bushes

Use tool **1281 + 1282**

Line up the lubrication holes.

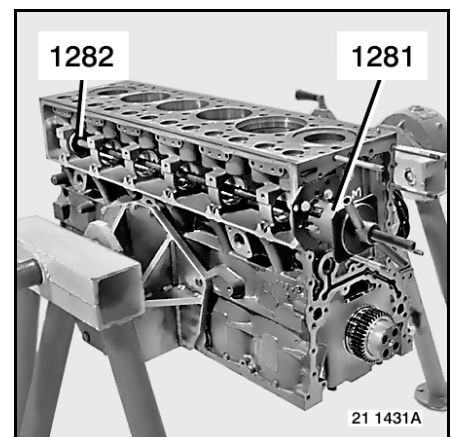

Camshaft pinion

Install key (8).

Heat the part (28) to 200°C.

Minimum heating time: 60 minutes.

Assemble pinion (28).

Let cool.

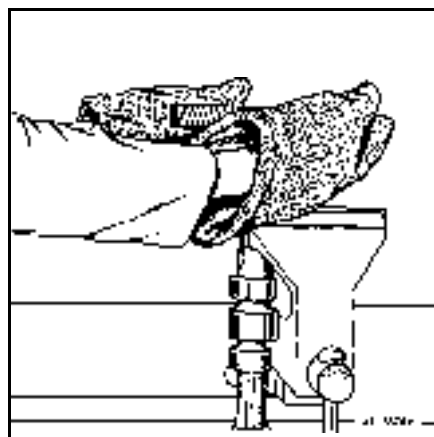
**Timing case**

Put deflector into place.

Use a press.

Use tool 2351 Ø 64 mm

Ensure dimension "A = 3.5 → 4.0 mm".

Air compressor pinion

Assemble pinion.

Fit the washer.

Screw up nut.

Tighten to torque.

See page B-2-5

Hydraulic pump pinion

Assemble pinion.

Fit the washer.

Screw up nut.

Tighten to torque.

See page B-2-3

Water pump

See page B-2-5

Fan hub

See page B-2-5

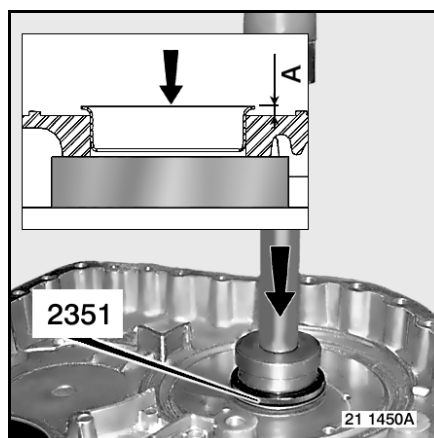

Fitting

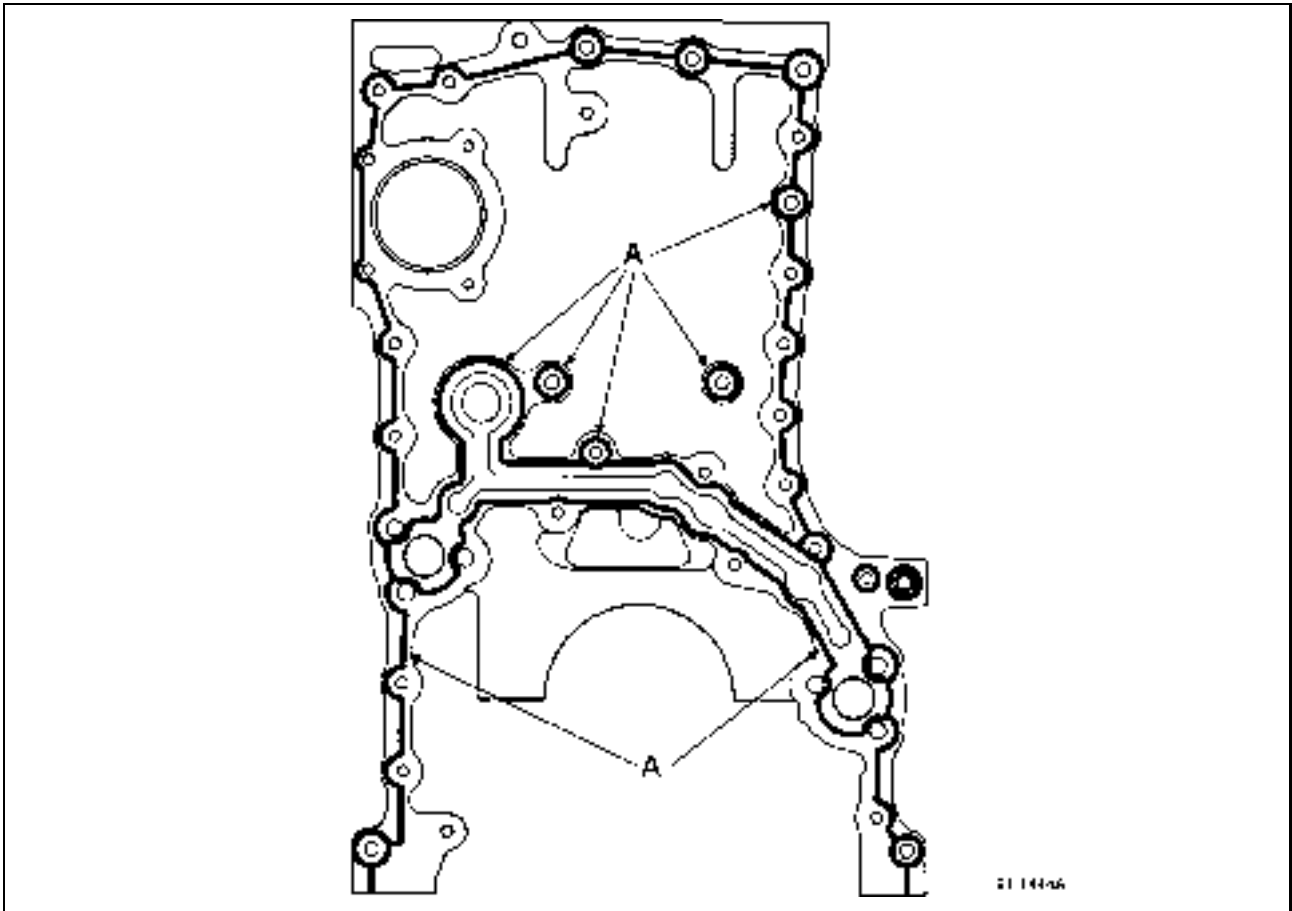

Front plate

Ensure a tight seal with a sealing product "RECTIJOINT 518" (A).

Fit front plate (12).

Fit clamp (30).

Fit setscrews.

Screw up without tightening.

Install hubs (24 - 29).

Fit setscrews.

Tighten to torque.

See page B-2-2

Crankshaft pinion

Install key (11).

Apply oil.

Assemble pinion (25).

Match the direction of orientation.

Fit spacer (18).

Position the crankshaft with N° 1 cylinder at TDC.

Use tool 1380.

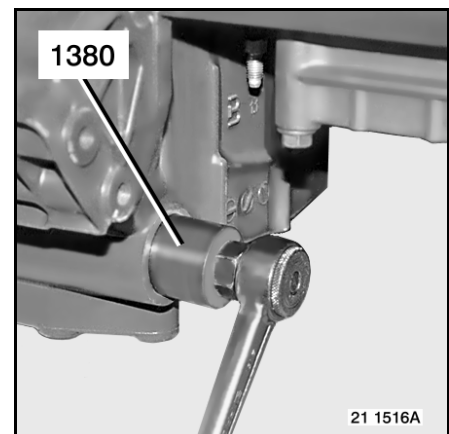

Oil pump

Check for the presence of locating sockets (A).

Assemble oil pump (15).

Fit setscrews.

Tighten to torque.

Check the backlash.

See page B-3-3

Apply oil.

Install O-rings.

Assemble pipe (16).

Fit setscrew.

Tighten to torque.

See page B-2-4

Idler gears

Apply oil.

Fit the pinions (22 - 27)

Ensure the marking.

See page B-3-3

Install circlips (21 - 26).

Check the side play.

Check the backlash.

See page B-3-3

Camshaft

Apply oil.

Fit the camshaft assembly (9).

Ensure the marking.

Install stop (10).

Fit setscrews.

Use a threadlocking and sealing product "FRENETANCH 242".

Tighten to torque.

Check the backlash.

Check the side play.

See page B-3-3

High pressure pump

Install high-pressure pump.

See page J-2-13

Degrease the tapers.

Install key.

Assemble pinion (23).

Ensure the marking.

Screw up nut (20).

Tighten to torque.

Check the backlash.

See page B-3-3

Fit impeller (19).

Tighten to torque.

See page B-2-4

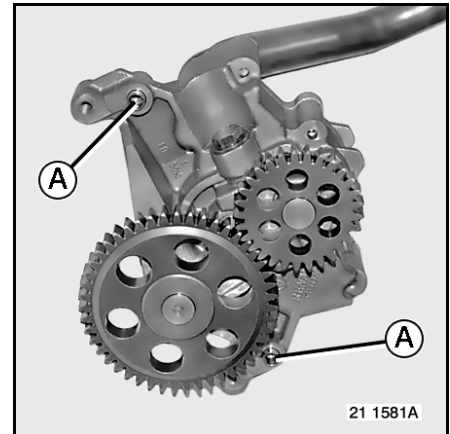

21 1581A

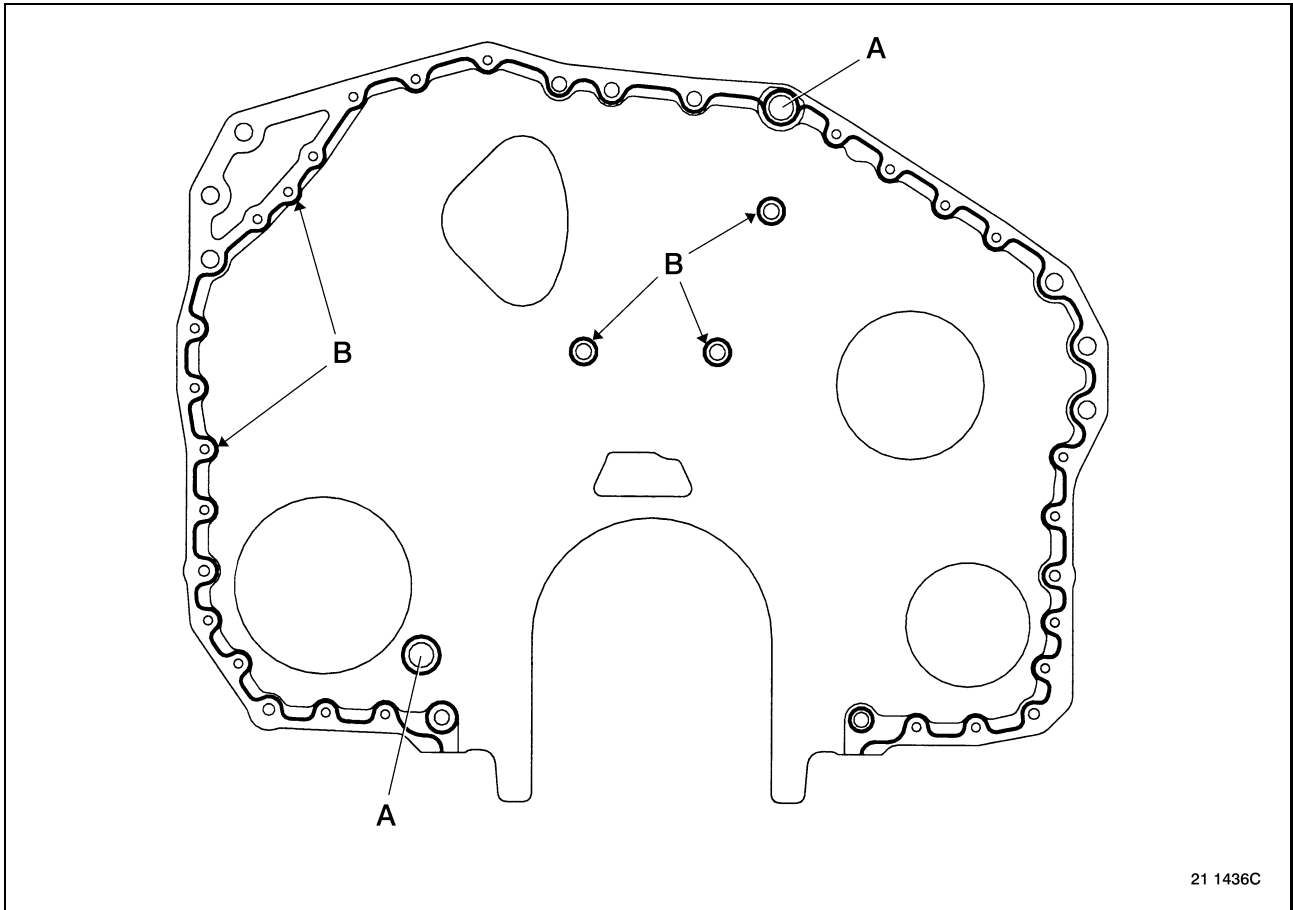

21 1436C

Timing case

Check for the presence of locating sockets (A).

Ensure a tight seal with a sealing product "RECTIJOINT 518" (B).

Fit timing case (1).

Fit setscrews.

Tighten to torque.

See page B-2-2

The tightening sequence starts with the screws in the middle and finishes with those on the outside.

Install O-ring (3).

Fit breather (2).

Tighten to torque.

See page B-2-2

Install tool 2561.

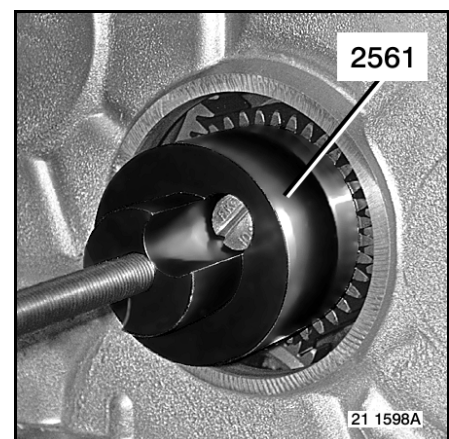

21 1598A

Install protective ring (A) to tool 2561
Match the direction of orientation.

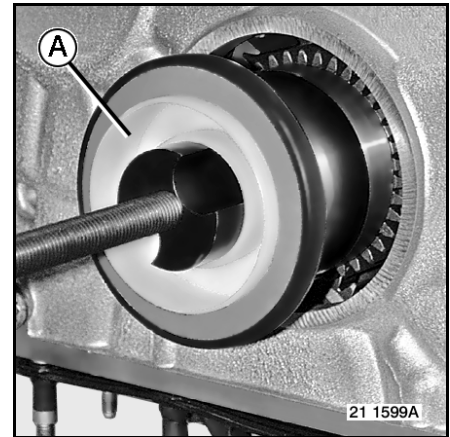

The gasket is supplied fitted to a protective ring that is placed on the assembly tool. It is essential to hold the gasket to the ring until it is finally installed in the case.

Do not apply grease to the lips.

Any gasket that has been removed from its ring must not be re-used.

Fit seal ring (4).

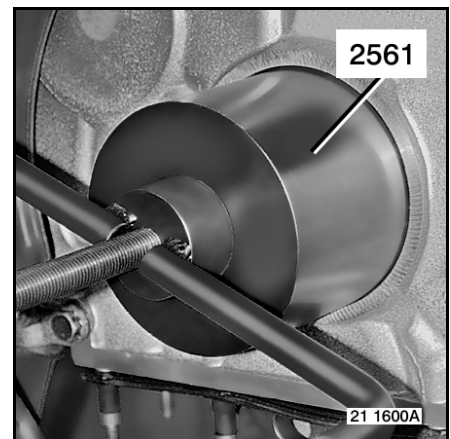

Withdraw protective ring (A).
Withdraw tool 2561.

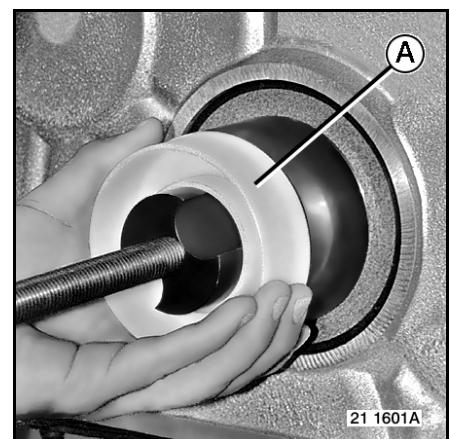

Damper

Install O-ring (17).
Fit damper.

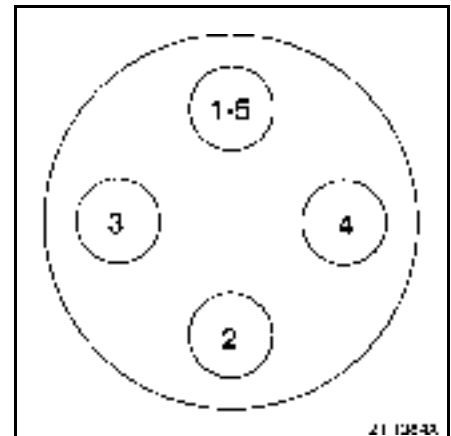

It is essential to replace the setscrews if the length under the head is more than 140 mm

Tighten to torque.

1° Preliminary tighten the bolts at $60 \pm 6 \text{ Nm}$ in the sequence shown from 1 to 5

2° Tighten the bolts at $180 \pm 6 \text{ Nm}$ in the sequence shown from 1 to 4

Lubrication of setbolts:

- **New setbolts:** These pre-lubricated bolts do not require any lubrication.
- **Re-used setbolts:** As early as the second fitment, lubricate the screw-thread under the head with **SPRAY MOLYCOTE GN PLUS DOW CORNING.**

Tappets

Apply oil.

Put tappets (7) into place.

Ensure the position

Fit the tappet retainers (6).

Fit setscrews.

Tighten to torque.

See page B-2-3

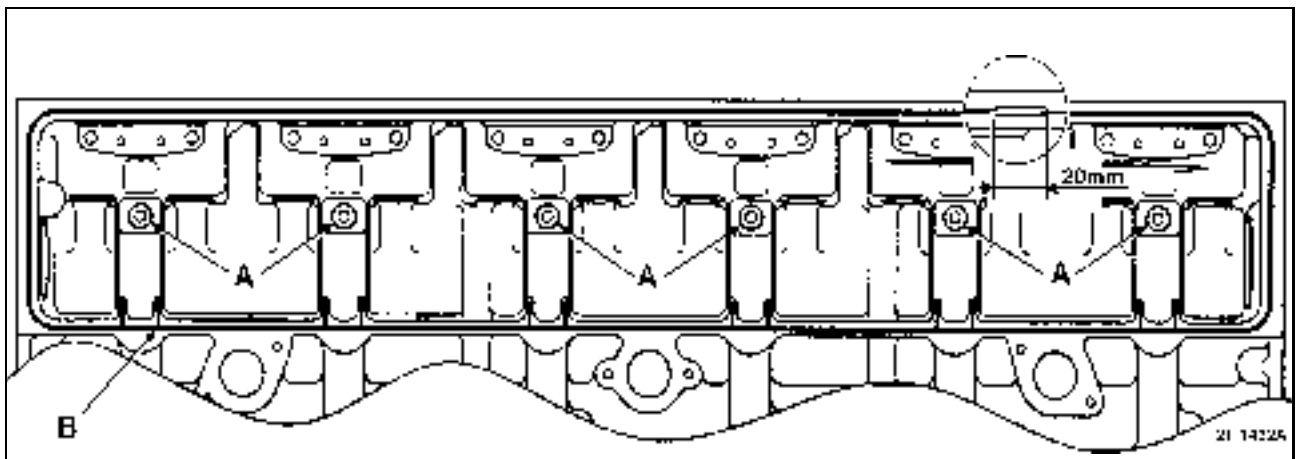

Ensure a tight seal with a sealing product "RECTIJOINT 518" (A) + "SILMATE RTV 1473" (B).

Fit the tappet cover (5).
 Match the direction of orientation.
 Fit setscrews.
 Tighten to torque.
See page B-2-2

Water pump

Fit water pump-thermostat housing unit.
See page I-3-4

Air compressor

Install O-rings.
 Fit the air compressor.
 Fit the nuts.
 Fit spacer.
 Fit screw.
 Ensure a tight seal with a threadlocking and sealing product **FRENETANCH 242**.
 Tighten to torque.
See page B-2-5

Hydraulic pump

Install O-ring.
 Fit the hydraulic pump.
 Tighten to torque.
See page B-2-2

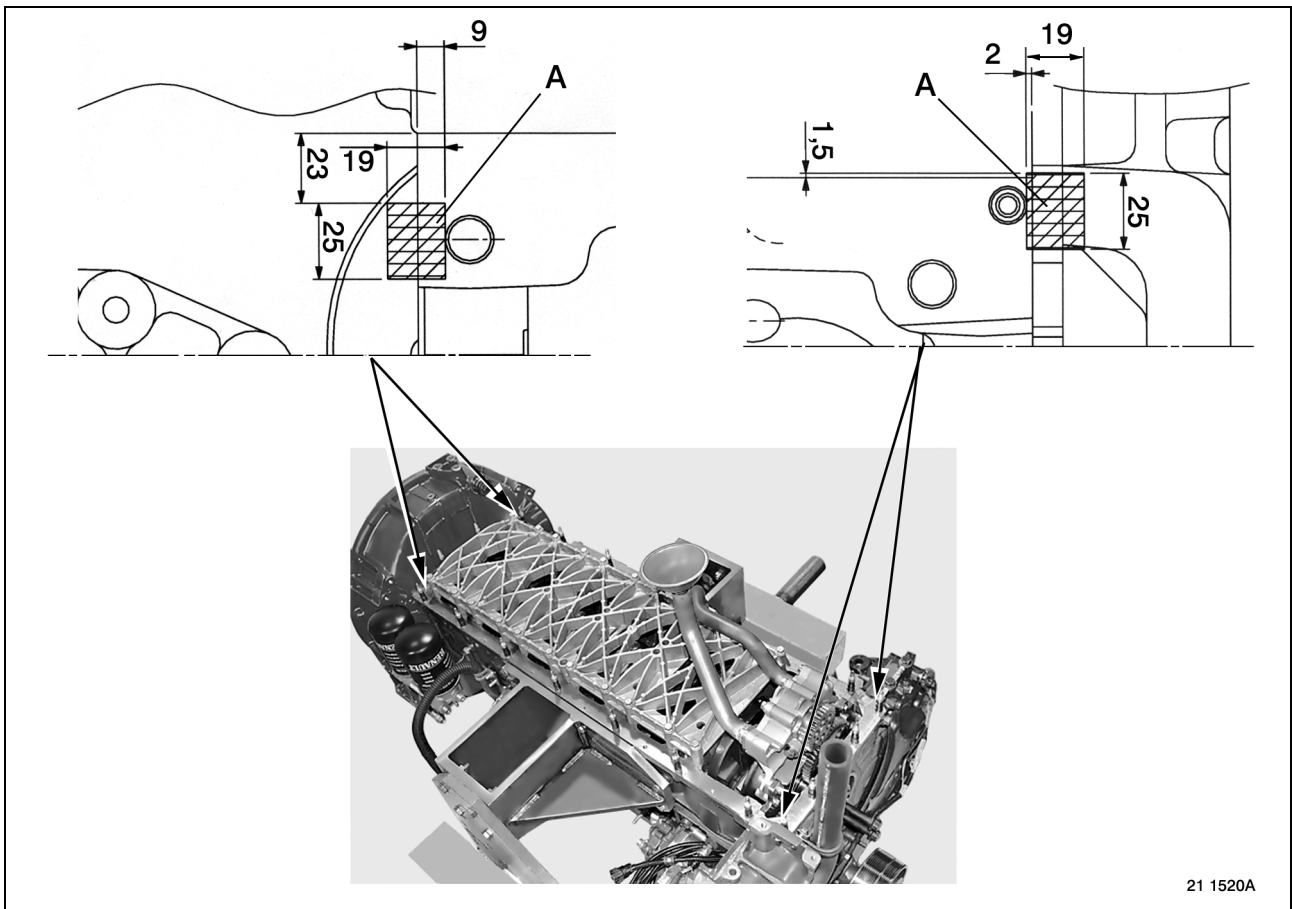
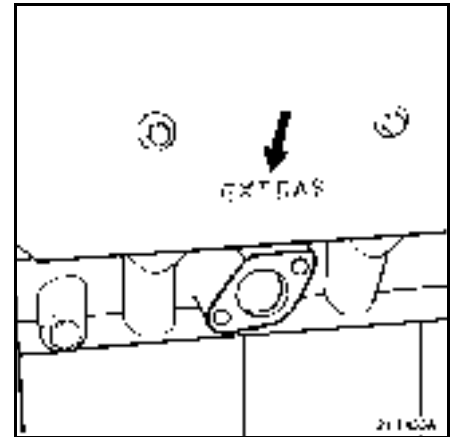

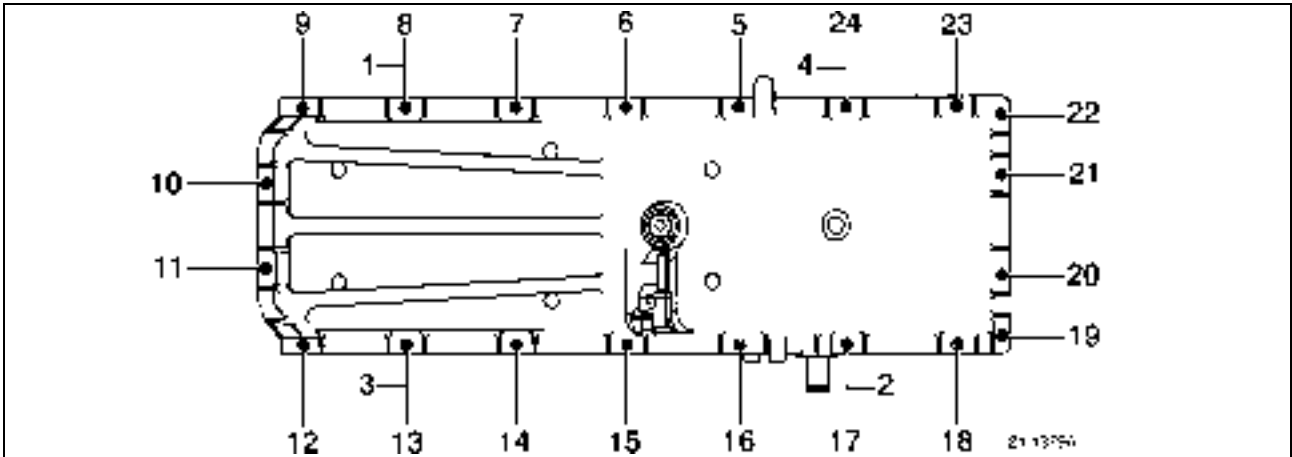

Oil sump

Check the tightness of the studs.

See page B-2-3

At the intersection of the casings, provide a tight seal with adhesive tape VHB.

Install seal (13).

Fit the oil sump (14).

Install the spacers.

Fit the nuts.

In the indicated sequence

Tighten to torque.

See page B-2-3

Fit the oil level sender.

Tighten to torque.

See page B-2-4

Use tool 2537.

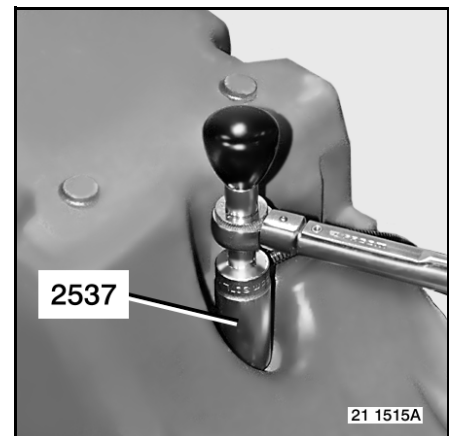

To find Top Dead Centre:

Use tool 1380 to turn the crankshaft.

- Turn the crankshaft (clockwise) to bring the valves of N° 1 cylinder into balance (end of exhaust / commencement of admission).
- Place a locally manufactured pointer (a)
- Turn the crankshaft (clockwise) through 3/4 of a revolution.
- Insert a shim (c) with parallel faces (thickness: 7 mm) between the inlet valve yoke of N° 1 and the rocker arm.
- Turn the crankshaft slowly (clockwise) to bring the piston into contact with the valve.

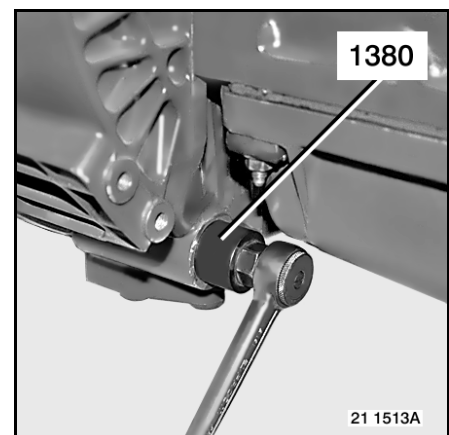

Do not exert too much force.

- Align the letter (A) on the flywheel opposite the locally manufactured pointer (a).
- Turn the engine (anticlockwise) through a few degrees
- Withdraw the shim (c).
- Turn the crankshaft (clockwise) through 1/4 of a revolution.
- Once again insert the shim (c) between the yoke of the inlet valve of N° 1 and the rocker arm.
- Slowly turn the crankshaft (anticlockwise) to bring the piston into contact with the valves.

Do not exert too much force.

- Align the letter (B) on the flywheel opposite the locally manufactured pointer (a).
- Turn the crankshaft (clockwise) through a few degrees.
- Withdraw the shim (c).
- Scribe the mid-point (C) of the quadrant (A-B).
- Turn the crankshaft (anticlockwise) to bring TDC (C) opposite the locally manufactured pointer (a).

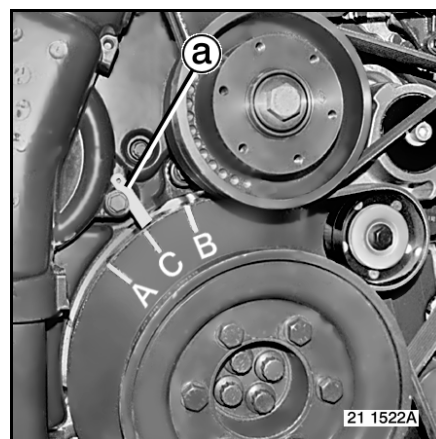
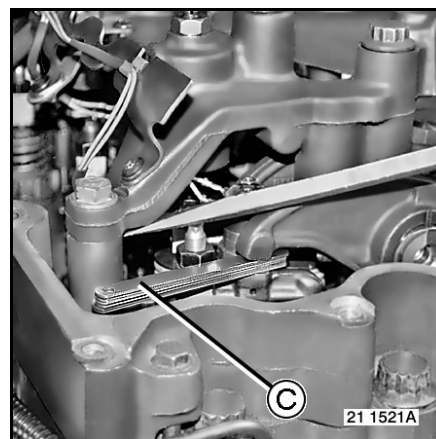

RECIPROCATING GEAR

Exploded view

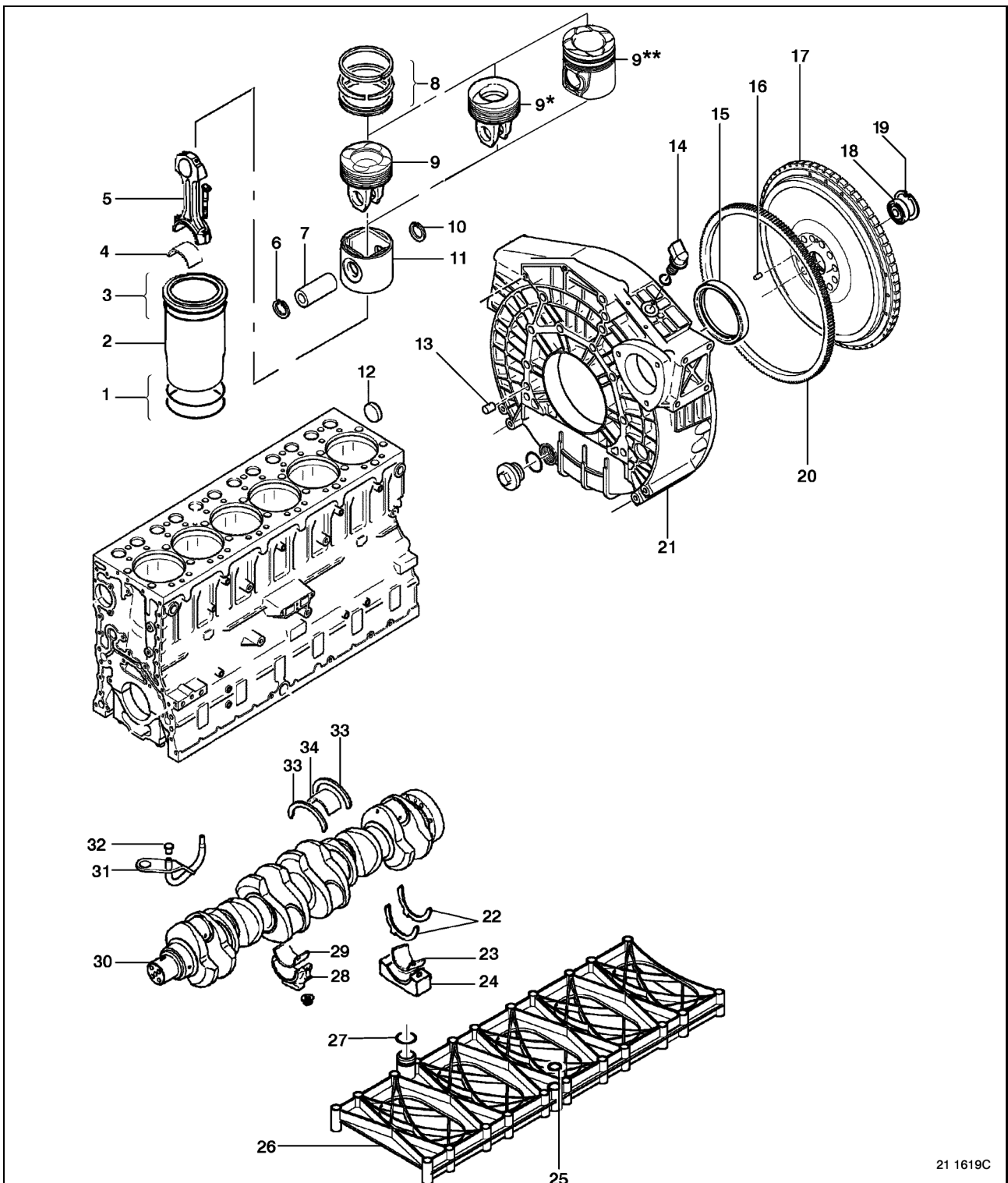

* Only for: dCi 11 B43

** Only for: dCi 11 (variant 14102) E + J01, G + J01, I + J01, F + J01, H + J01.

Disassembly

The item numbers indicated in the text refer to the drawing on page G-2.

Flywheel

Remove the engine speed sensor (14).
Remove flywheel (17).
Remove the casing (21).
Withdraw seal ring (15).

Oil nozzles

Remove engine block stiffener (26).
Remove the sensor (25 - 27).
Remove setscrews.
Remove oil nozzles (31).
Take out seals (32).

Connecting rods

Pistons

Check that the connecting rod markings are effectively present (end opposite camshaft).
Remove connecting rod caps (28).
Remove bearing half-shells (29).
Classify the parts in order.
Withdraw connecting rod/piston assemblies.
Remove bearing half-shells (4).
Classify the parts in order.

Crankshaft

Check for the presence of main bearing cap marks.
Remove the bearing caps (24).
Remove bearing half-shells (23).
Remove the half-rings (22).
Classify the parts in order.
Remove crankshaft (30).
Remove the half-rings (33).
Remove bearing half-shells (34).
Classify the parts in order.

Pistons

Remove piston rings (8).
Use tool 0825.

Connecting rods

Withdraw circlips (6 - 10).
Drive out gudgeon pins (7).
Separate crowns (9) from skirts (11).

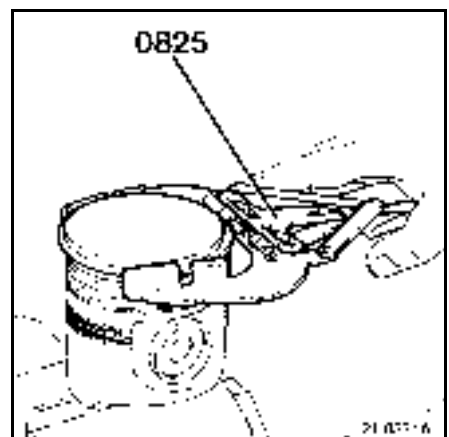
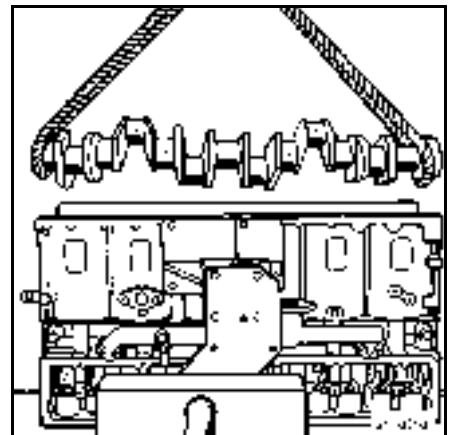
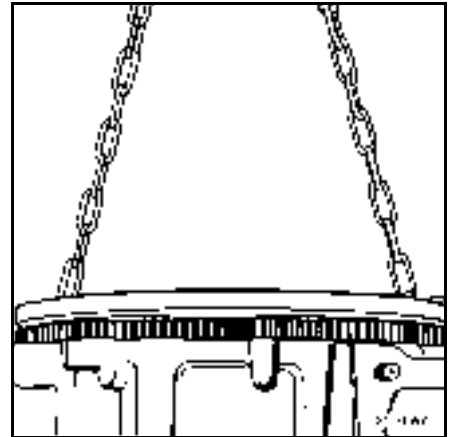

Liners

Withdraw liners (2).
 Use tool **1230 + 2334**
 Take out seals (1 - 3).

Cylinder block

For replacement only.
 Remove the cup (12).
 Remove plugs.
 Thoroughly clean all conduits.

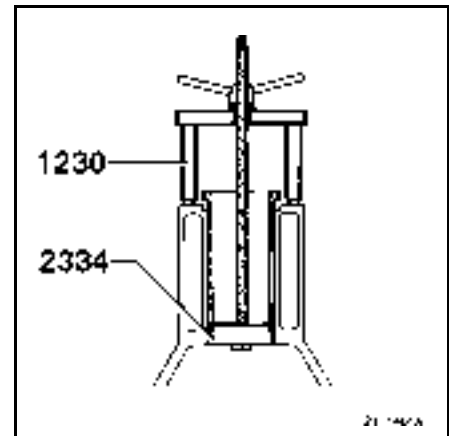
**Flywheel****Manual gearbox and Astronic version**

Remove circlip (19).
 Save bearing (18).
 For replacement only.
 Remove the gear ring (20).
 Use setscrews **M10**.

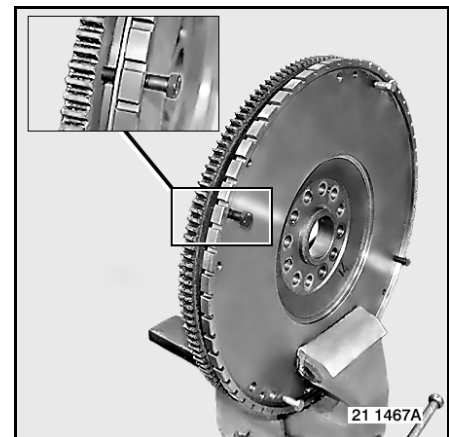
**Automatic transmission version**

For replacement only.
 Remove the gear ring (20).

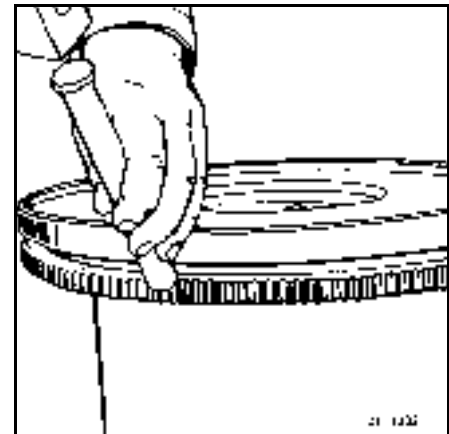
**Inspection****Cylinder block**

Check the mating surface.

Inspect the liners

- out-of-round,
- taper.

Inspect the pistons:

- diameter,
- gudgeon pin and housing,
- grooves and piston rings.

Inspect the piston rings:

- thickness,
- piston groove clearance,
- joint gap.

Inspect the connecting rod:

- squareness and truing up
- bushes.

Inspect the crankshaft:

- co-axiality,
- crankpin diameters,
- crank journal diameters.



Straightening of the crankshaft is forbidden.

Assembly**Flywheel**

Heat part (20) to **200°C**.

If a welding torch is used, take a sheet metal plate and heat it to distribute the heat evenly. Check the temperature at 3 points (A).

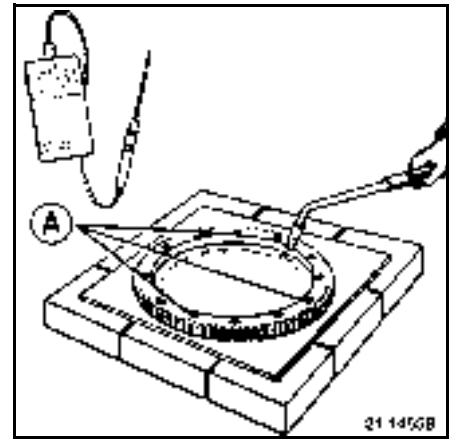

Fit crown wheel (20).

Match the direction of orientation.

Let cool.

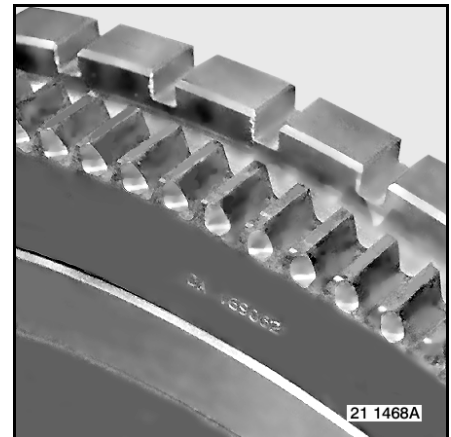
**Cylinder block**

If necessary

Fit the cup (12).

Use tool **3016 + 2363 Ø 55 mm**.

Use a thread locking product "**FRENETANCH 242**".

Ensure a set-back (**A = 2 ± 0.5 mm**).

Fit the plugs.

Use a thread locking product "**FRENETANCH 242**".

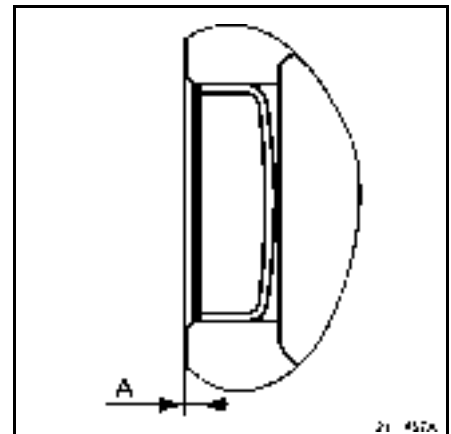

Liners

Install O-rings **(3)**.

Install O-rings **(1)**.

Ensure the position

Black O-ring **(A)** at the top.

Green O-ring **(B)** at the bottom.

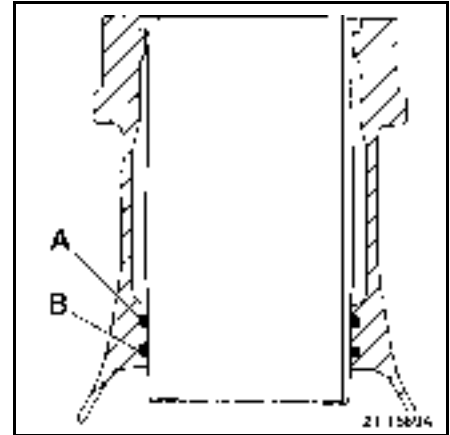

Before assembly: do not oil the gaskets.

After assembly: oil the exposed part of the gaskets.

Fit liners **(2)**.

Immobilize the liners **(2)**.

Use tool **1462**.

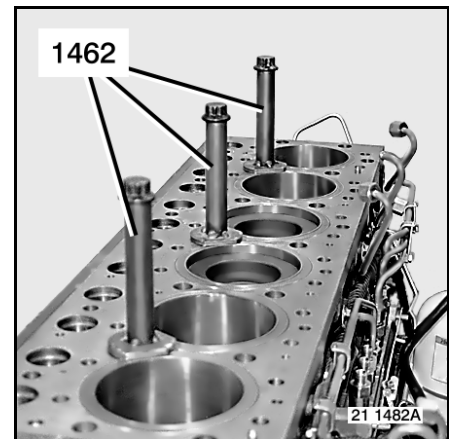

Check the protrusion of the liners.

Ensure dimension "A".

See page B-3-7

Crankshaft

Fit bearing half-shells **(34)**.

Line up the lubrication holes.

Apply oil.

Fit crankshaft **(30)**.

Install thrust half-rings **(33)**.

Match the direction of orientation.

Fit bearing half-shells **(23)**.

Install thrust half-rings **(22)**.

Match the direction of orientation.

Apply oil.

Fit bearing caps **(24)**.

Match the direction of orientation.

Fit setscrews.

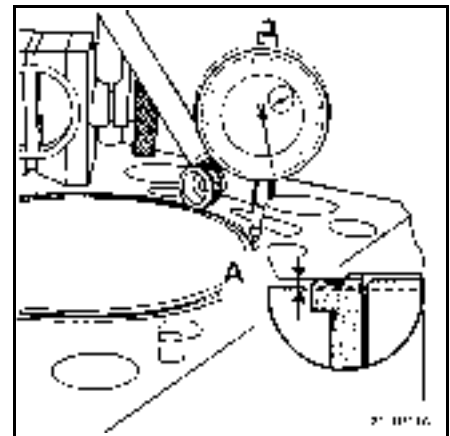

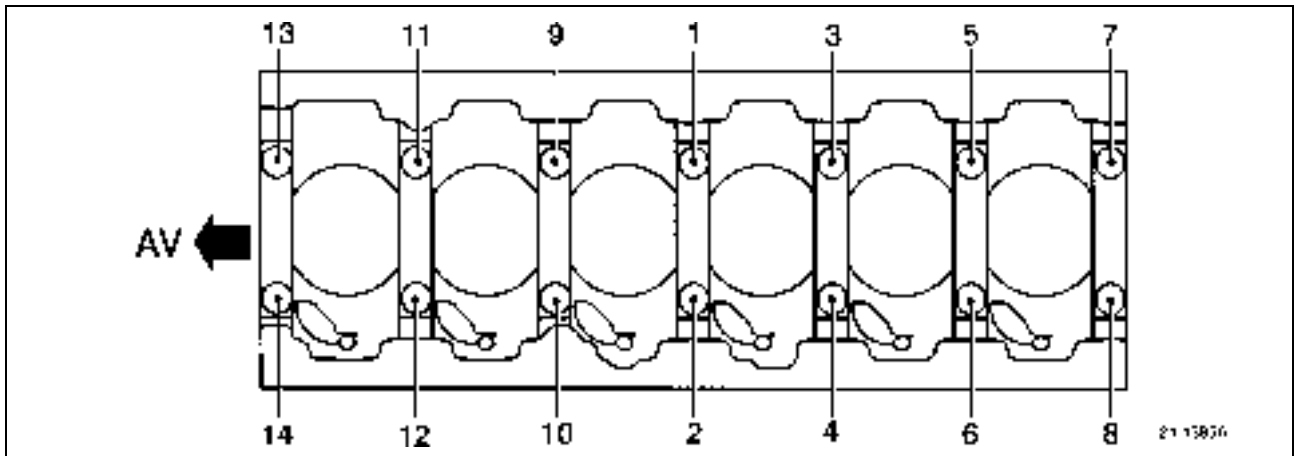

Tighten to torque.

In the indicated sequence:

- Start the setsbolts
- Preliminary tighten at 80 ± 8 Nm
- Final tighten at $180^\circ \pm 6^\circ$



It is essential to replace the setscrews if the length under the head is more than 156 mm



*The setscrews can be re-used. In such case, apply **SPRAY MOLYCOTE GN PLUS DOW CORNING** spray to the screw-threads and under the screw heads.*

Do not apply any product to new setscrews that are already pre-lubricated.

Check the rotation.

Check the play (**A**).

See page B-3-7

Correct, if necessary.

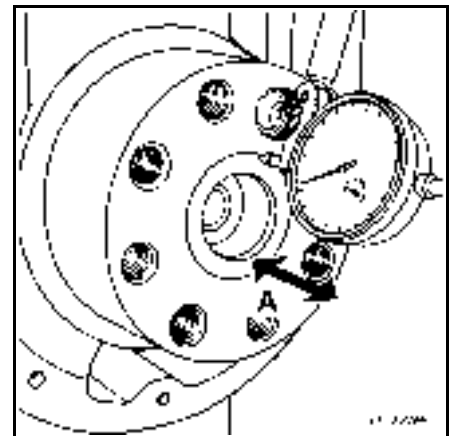

Connecting rods

Pistons

Version dCi 11 B43

Apply oil.

Assemble piston crowns (9), skirts (11) and connecting rods (5) with gudgeon pins (7).

Match the direction of orientation.

Install circlips (6 - 10).

Fit setscrews.

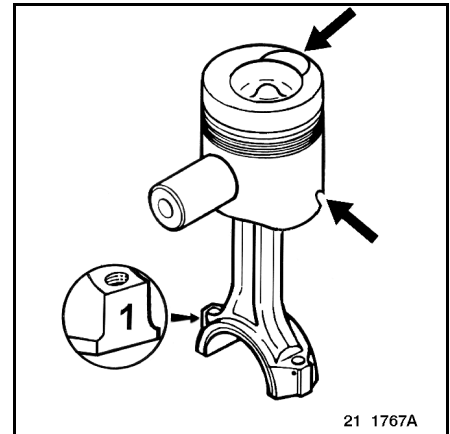

Version dCi 11 + J01

Apply oil.

Assemble piston crowns (9), skirts (11) and connecting rods (5) with gudgeon pins (7).

Match the direction of orientation.

Install circlips (6 - 10).

Fit setscrews.

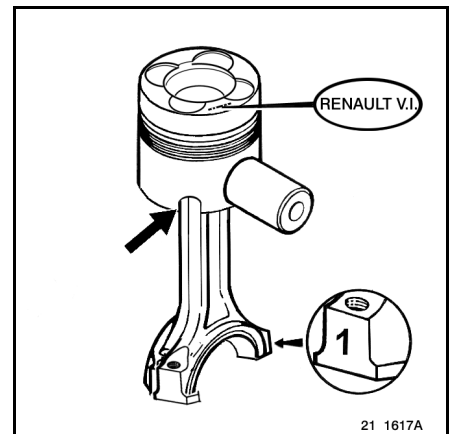

Version dCi 11

(variant 14102) E + J01, G + J01, I + J01, F + J01, H + J01.

Apply oil.

Assemble pistons (9) and connecting rods (5) with gudgeon pins (7).

Match the direction of orientation.

Install circlips (6 - 10).

Fit setscrews.

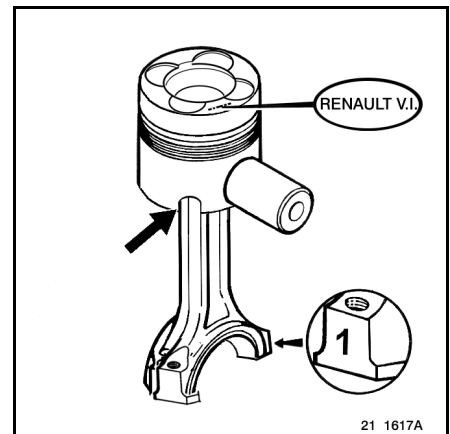

Install piston rings (8).

Match the direction of orientation.

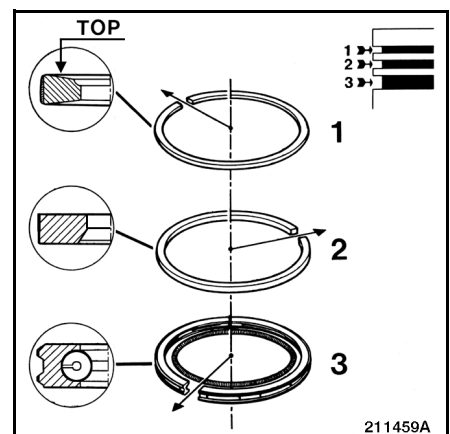

Use tool **0825**.
Fit bearing half-shells **(4)**.
Match the direction of orientation.
Apply oil.

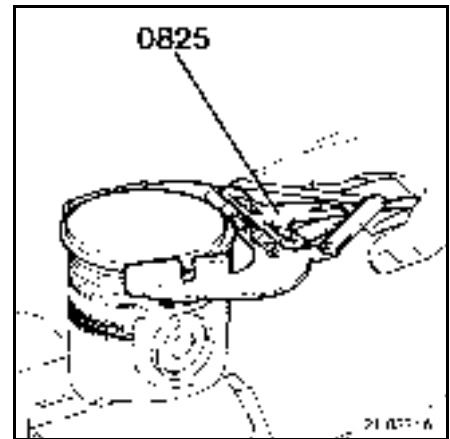

Version dCi 11 B43

Apply oil.
Install connecting rod/piston assemblies.
Match the direction of orientation.

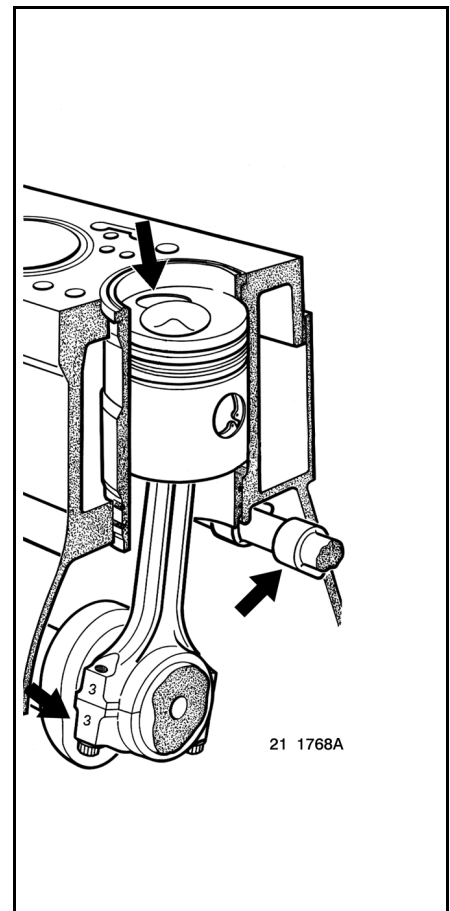

Version dCi 11 + J01

Apply oil.

Install connecting rod/piston assemblies.

Match the direction of orientation.

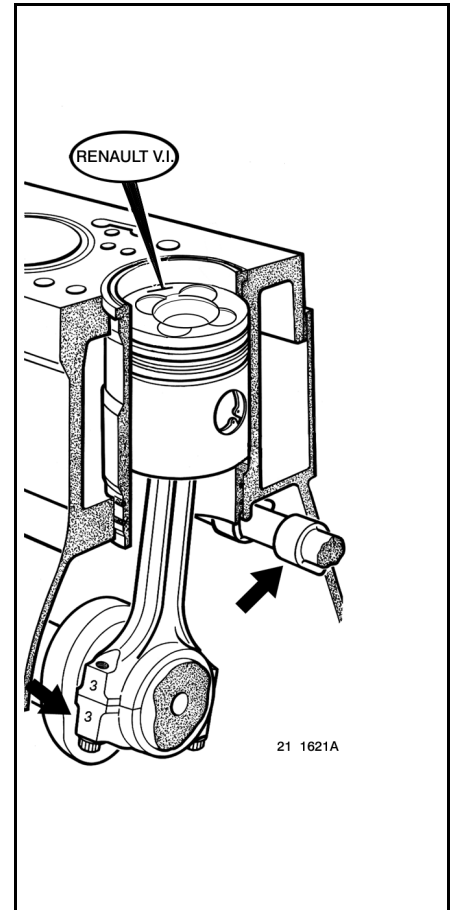

Use tool **2560**.

Fit bearing half-shells (**29**).

Apply oil.

Fit connecting rod caps (**28**).

Fit the nuts.

Tighten to torque.

Before tightening the nuts, apply a film of oil to the screw-threads and to the contact face of each nut:

- Start the nuts
- Preliminary tighten at $80 \pm 8\text{Nm}$
- Final tighten at $90^\circ \pm 6^\circ$

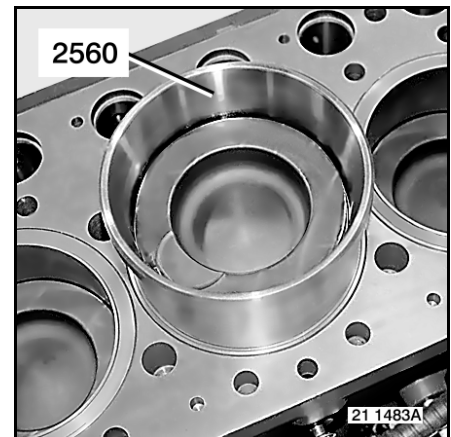

Check the pistons protrusion.

Ensure dimension "A".

See page B-3-7

Oil nozzles

Install seals (**32**).

Fit the oil nozzles (**31**).

Fit setscrews.

Tighten to torque.

See page B-2-4

Apply oil.

Install seals (**25 - 27**).

Assemble engine block stiffener (**26**).

Fit setscrews.

Tighten to torque.

See page B-2-3

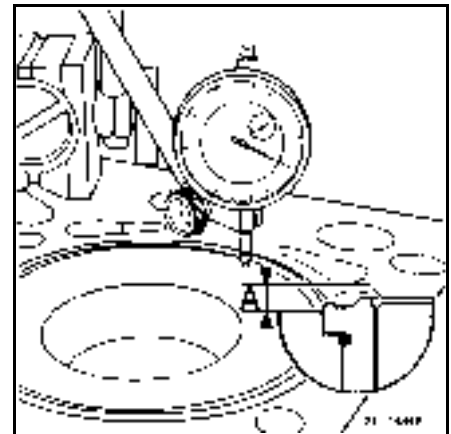

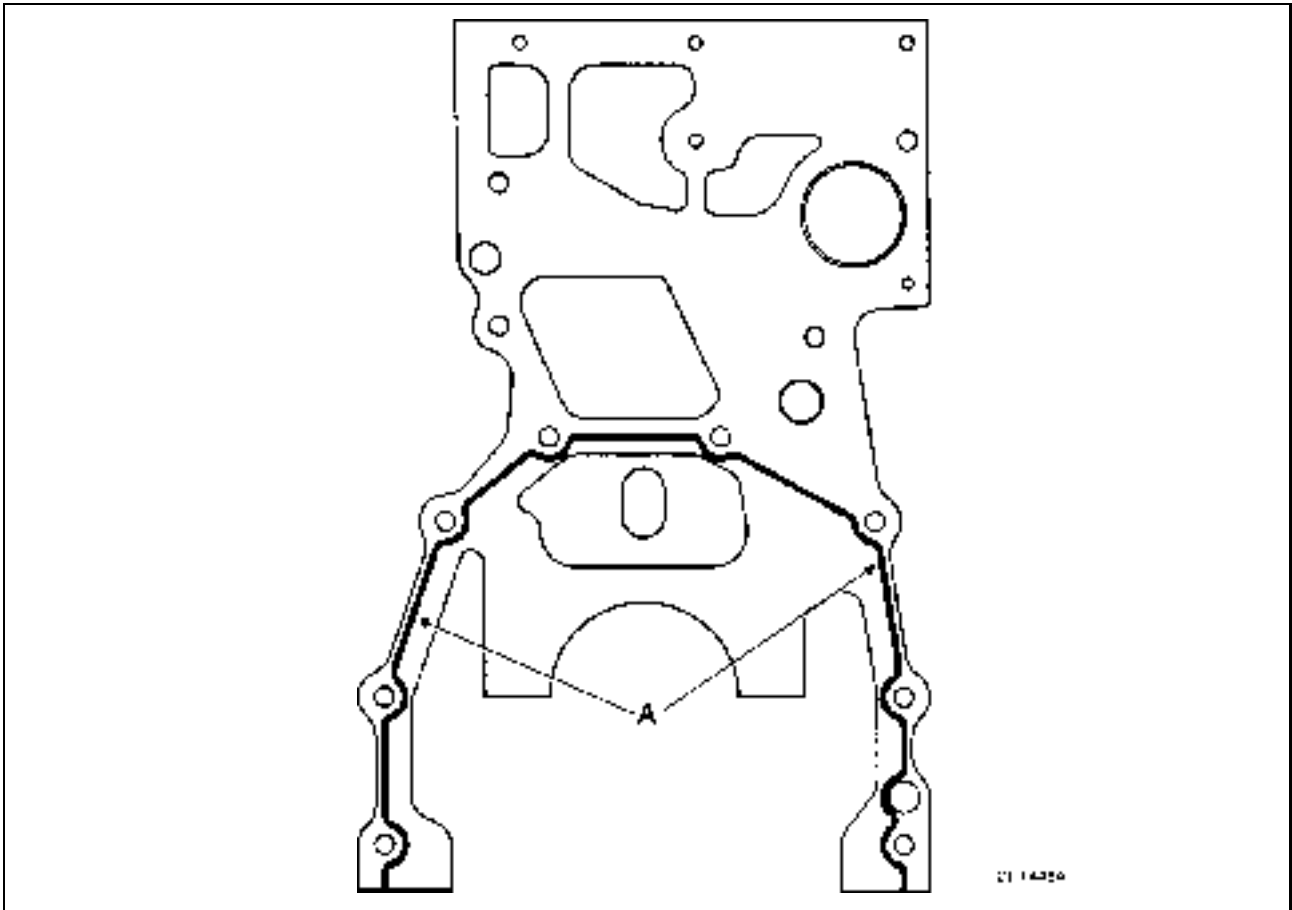
**Flywheel**

Fit the clamps (13).

Fit the housing (21).

Ensure a tight seal with a sealing product "RECTIJOINT 518" (A).

Fit setscrews.

Tighten to torque.

See page B-2-3

Install tool 2562.

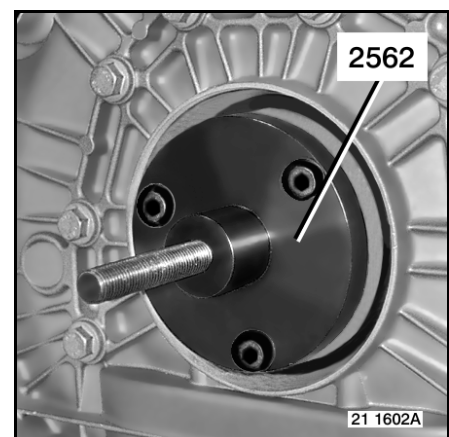

Install protective ring (A) to tool 2562
Match the direction of orientation.

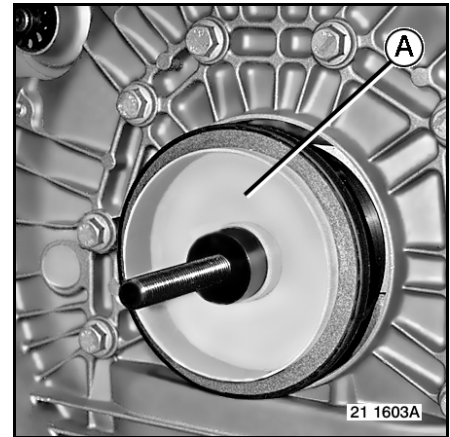

The gasket is supplied fitted to a protective ring that is placed on the assembly tool. It is essential to hold the gasket to the ring until it is finally installed in the case.

Do not apply grease to the lips.

Any gasket that has been removed from its ring must not be re-used.

Fit seal ring (15).

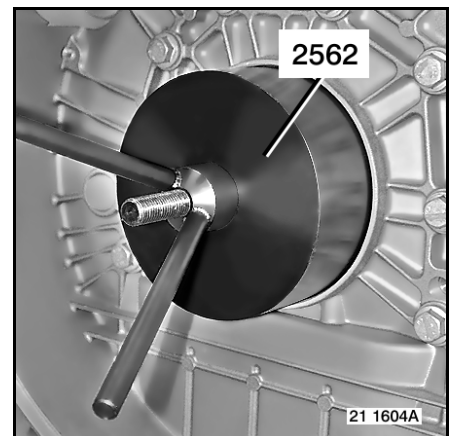

Withdraw protective ring (A).
Withdraw tool 2562.
Fit the clamps (16).
Install bearing (18).
Install circlip (19).
Fit the engine flywheel (17).

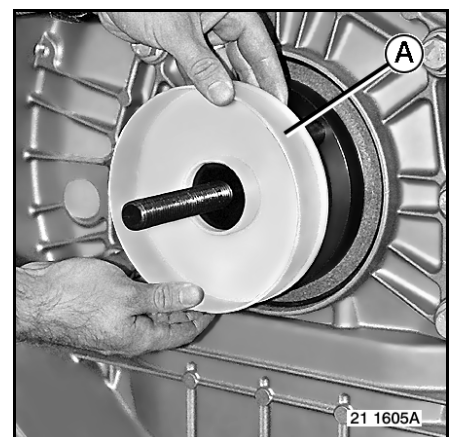

Fit setscrews.

Assembly with manual gearbox

Tighten to torque.

In the indicated sequence:

- Start the setbolts
- Preliminary tighten at $60 \pm 6 \text{ Nm}$
- Final tighten at $120^\circ \pm 6^\circ$

Assembly with automatic transmission

Tighten to torque.

In the indicated sequence:

- Start the setbolts
- Preliminary tighten at $100 \pm 10 \text{ Nm}$
- Final tighten at $150^\circ \pm 6^\circ$

Assembly with power take-off

Tighten to torque.

In the indicated sequence:

- Start the setbolts
- Preliminary tighten at $100 \pm 10 \text{ Nm}$
- Final tighten at $180^\circ \pm 6^\circ$

To facilitate tightening, you are advised to oil the support surface under the bolt head.

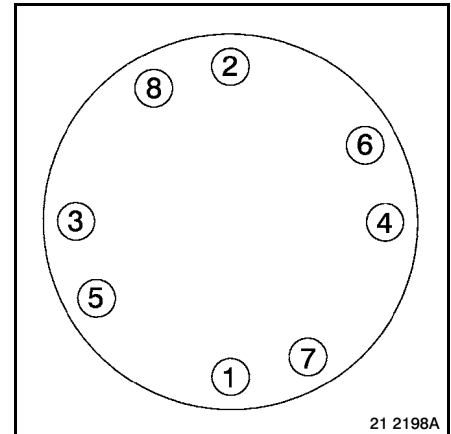

21 2198A

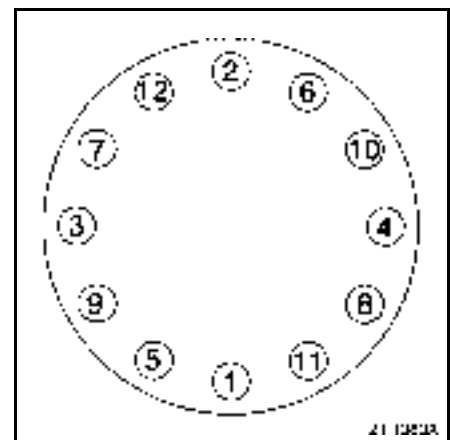

21 1282A

Re-use of setbolts

These bolts can be re-used no more than once.

Whenever you re-use them, mark the bolt with an indentation using a centre punch.

It is vital to replace any bolts already bearing a centre punch mark.

Fit engine speed sensor (14).

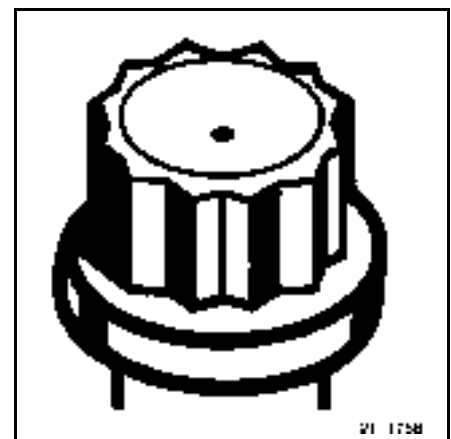

21 175M



The setbolts can only be used one single time. In such case, apply a Loctite type threadlocking and sealing product loctite Frenétanch to the screw-threads.

Do not apply this product to new setbolts that are already pre-coated.

LUBRICATION

Oil filter

Assembly

Throw-away oil filter cartridge

To replace, unscrew the cartridge (1).

Upon fitting:

Fill the cartridge (1) with oil.

Oil the seal

Screw up the cartridge(s) until contact is made with the support bracket.

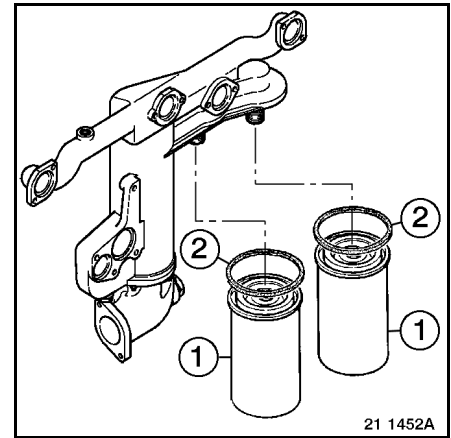

- Tighten at a torque of 25 ± 5 Nm
- Use tool 2655
- Use a torque wrench

Run the engine and check for leaks.

In the event of leakage, remove the cartridge(s), inspect the joint face and repeat the fitting operations.

Centrifugal oil filter

Disassembly

Remove the filter bracket/filter assembly.

Save gasket (8).

Unscrew nut (1).

Withdraw cover (3).

Remove circlip (4).

Withdraw nut (1).

Take out O-ring (2).

Save gasket (5).

Remove centrifugal filter (6).

If necessary

Remove threaded pin (7).

Apply heat. This operation diminishes the strength of the "locking" product.

Thoroughly clean all conduits.

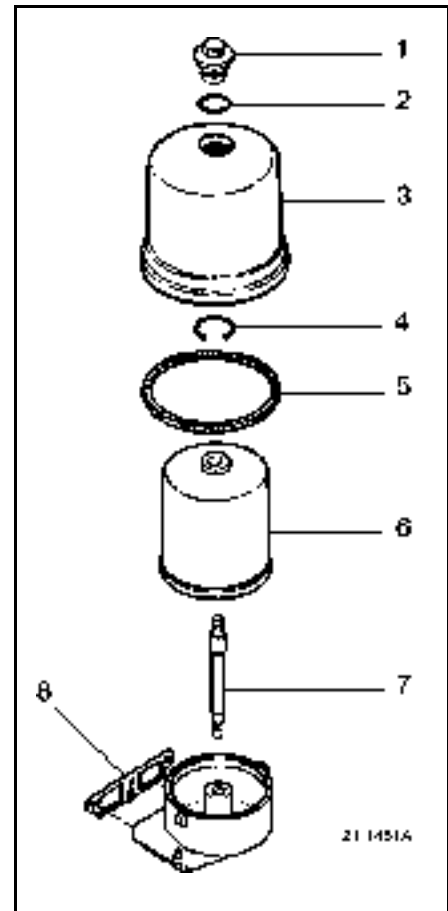

Assembly

If necessary

Fit pin (7).

Use a threadlocking and sealing product "FRENETANCH 242".

Tighten to torque.

See page B-2-4

Fit centrifugal filter (6).

Install seal (5).

Install seal (2).

Fit nut (1).

Install circlip (4).

Position cover (3).

Screw up nut (1).

Tighten to torque.

See page B-2-4

Install seal (8).

Remove the filter bracket/filter assembly support.

Tighten to torque.

See page B-2-2

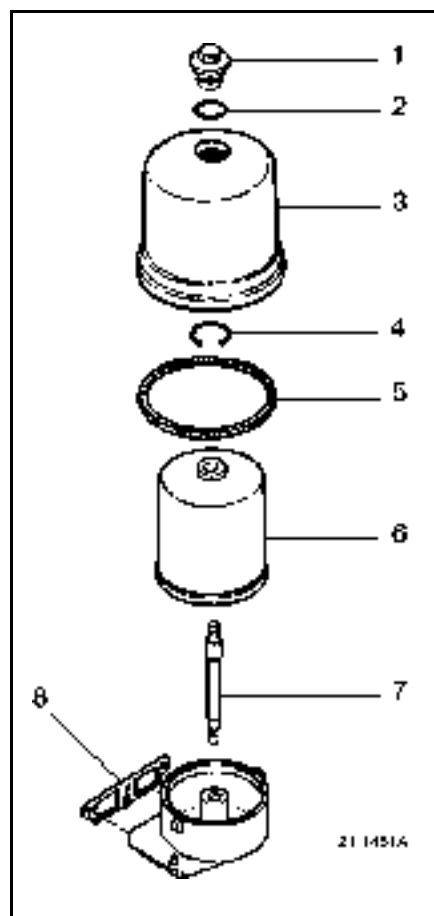

COOLING

Heat exchanger

Exploded view

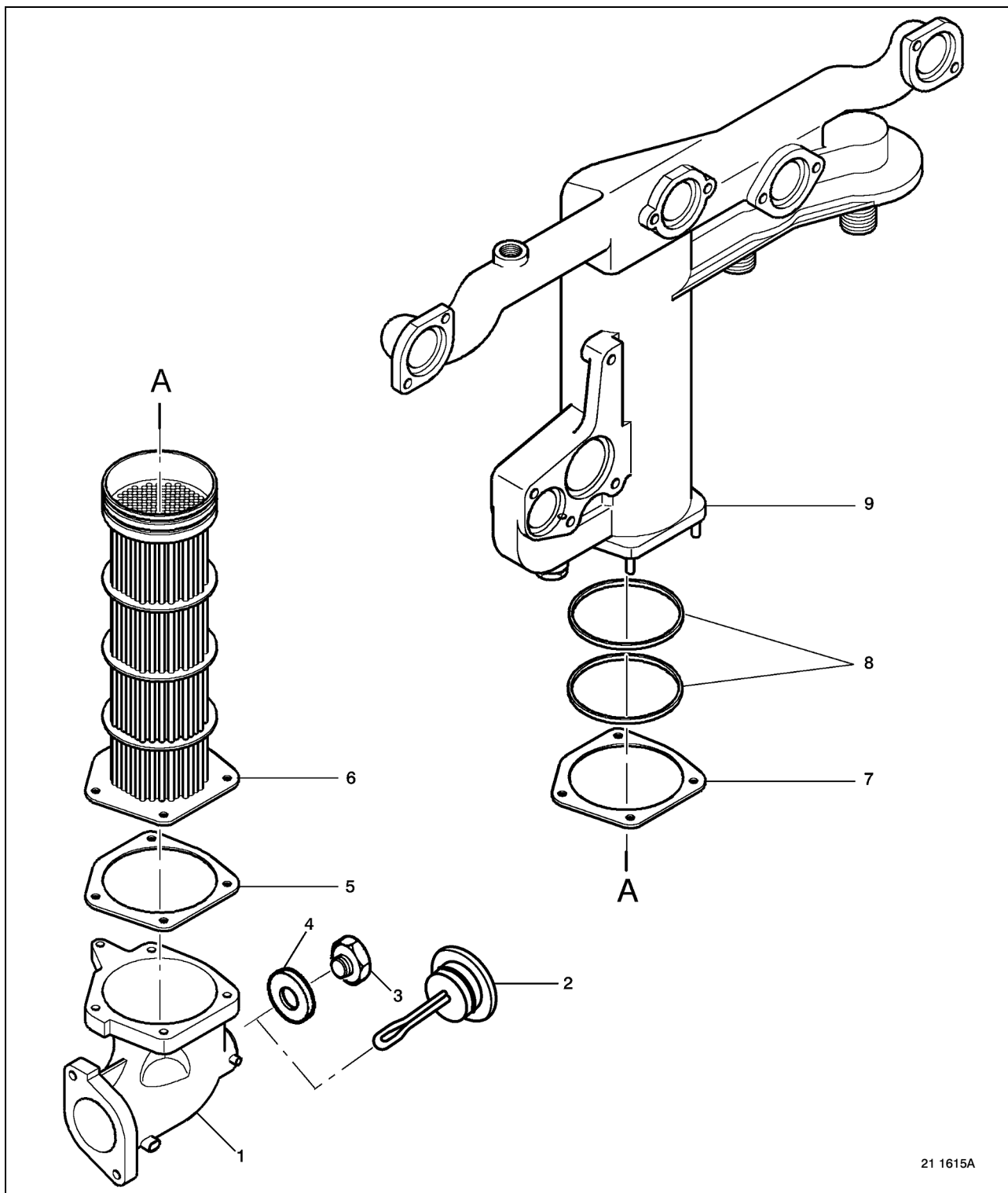

21 1615A

Disassembly

The item numbers indicated in the text refer to the drawing on page I-1-2.

Remove cover (1).

Withdraw gasket (5).

Depending on the assembly.

Remove setscrew (3).

Withdraw gasket (4).

Remove immersion heating rod (2).

Remove heat exchanger stack (6).

Withdraw gasket (7).

Remove the sensor (8).

Cleaning

Oil circuit: Use a degreasing product.

Water circuit: Use water mixed with a solution of 5 to 6 % hydrochloric acid. Allow to soak for about 30 minutes while stirring occasionally. Rinse with water mixed with a solution of 2 to 3 % bicarbonate of soda. Rinse with plenty of water. Dry the parts.

Assembly

Install O-rings (8).

Install seal (7).

Fit heat exchanger stack (6).

Depending on the assembly.

Fit immersion heating rod (2).

Install seal (4).

Fit setscrew (3).

Tighten to torque.

See page B-2-5

Install seal (5).

Position cover (1).

Tighten to torque.

See page B-2-2

Inspection

Install tool **2548 + 5000 040 416**.

Test for leaks in a hot water bath (80°C), air pressure: 6 bar(s), check for the absence of air bubbles.

Withdraw tool **2548 + 5000 040 416**.

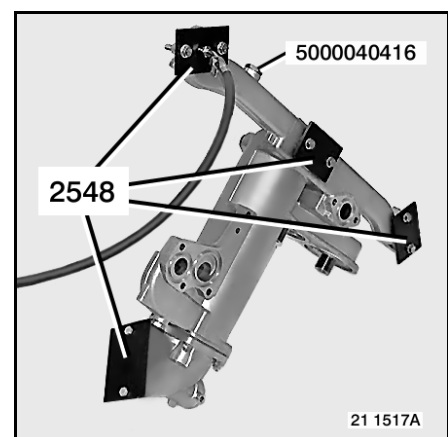

Ventilation control

Detailed view

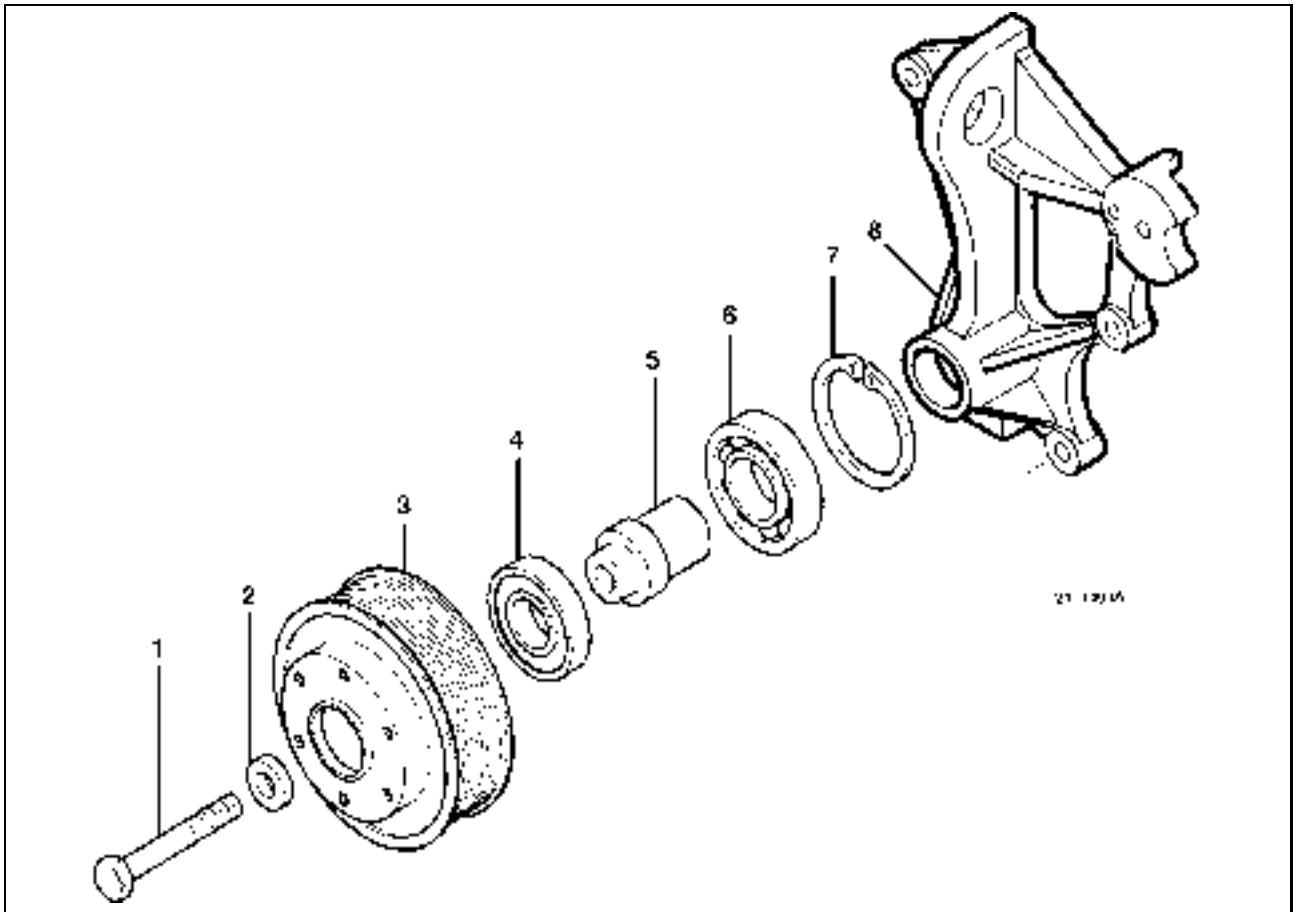

Disassembly

The item numbers indicated in the text refer to the drawing on page I-2-1.

Unscrew bolt **(1)**.

Fit nuts **(2)**.

Remove the bracket **(8)**.

Remove circlip **(7)**.

Use a press.

Drive out bearing shaft **(5)**.

Extract bearing **(6)**.

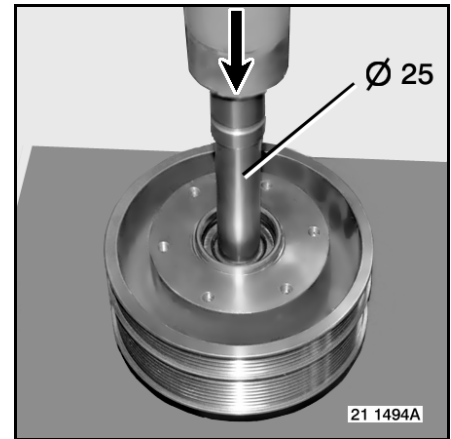

Use a press.

Extract bearing **(4)**.

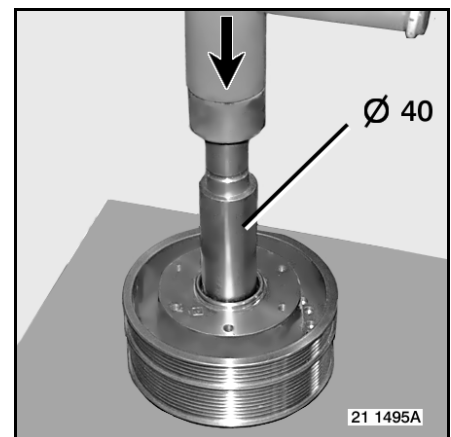

Assembly

The item numbers indicated in the text refer to the drawing on page I-2-1.

Use a press.
Install bearing (4).
Use tool 3016 + 2363 Ø 68 mm.

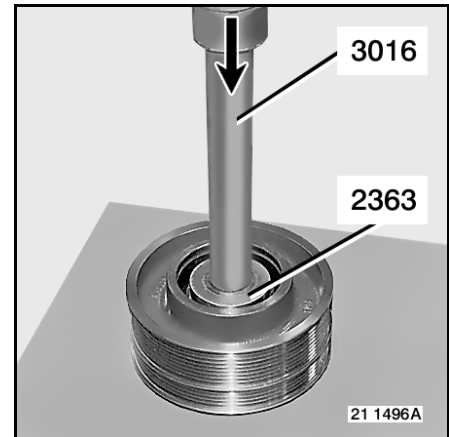

Use a press.
Install bearing shaft (5).

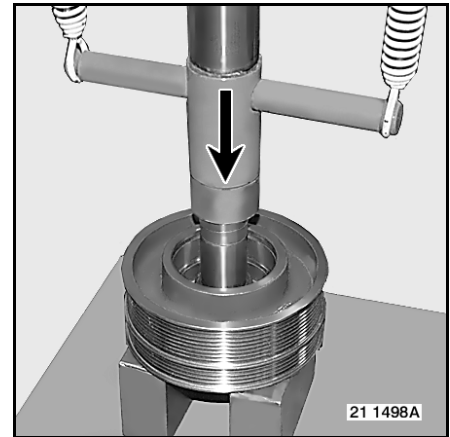

Use a press.
Install bearing (6).
Use tool 2513 Ø 55 x 40 mm
Fit the circlip (7).
Fit support (8).
Tighten to torque.
See page B-2-5

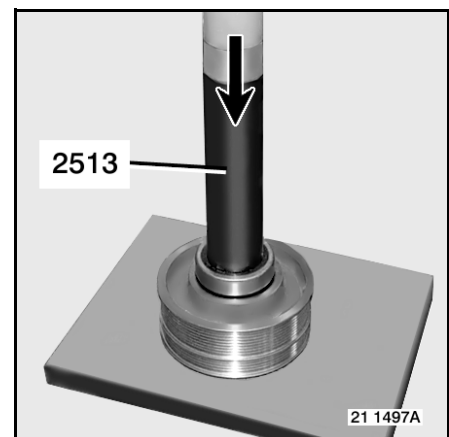

Water pump

Exploded view

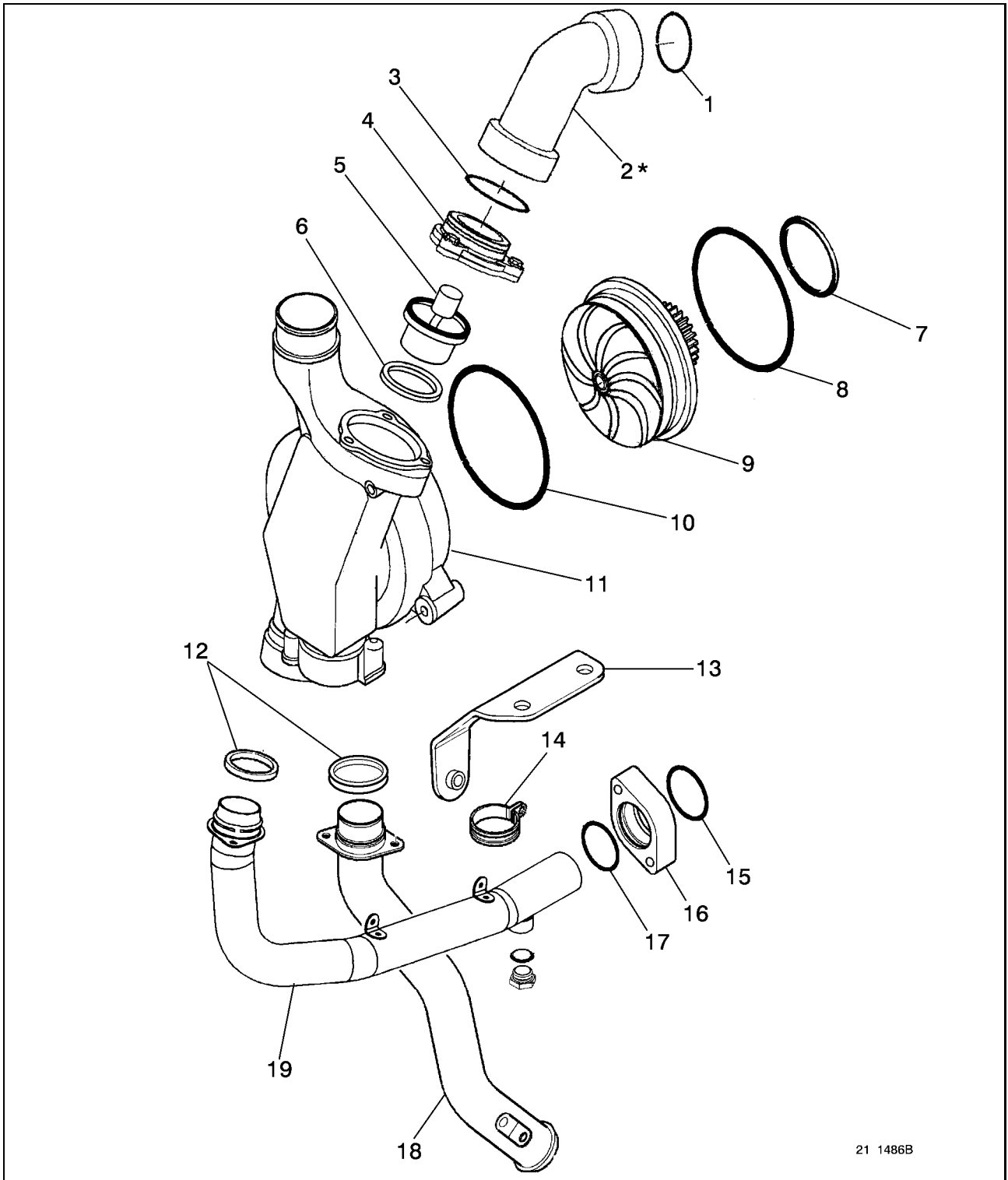

Removal

The item numbers indicated in the text refer to the drawing on page I-3-1.

Remove the assembly (2 - 4).

Remove the bracket (13).

Remove clamp (14).

Remove the flange (16).

Remove the assembly (9 - 11).

Withdraw pipe (18 - 19).

Take out seals (1 - 7 - 8 - 12 - 15 - 17).

Withdraw sleeve (4).

Fit fitting (3).

Disassembly

Remove the thermostat (5).

Withdraw seal ring (6).

Remove the water pump (9).

Withdraw gasket (10).

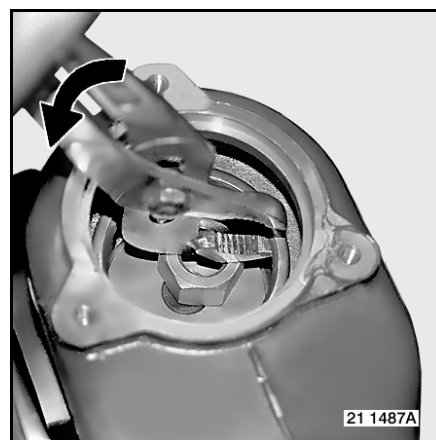

Inspection

Plunge the thermostat in a water bath. Heat progressively while stirring the water. Check the temperature at the commencement of opening. Measure (A) at a temperature of **90°C** for normal cooling, at a temperature of **98°C** arctic cold cooling pack.

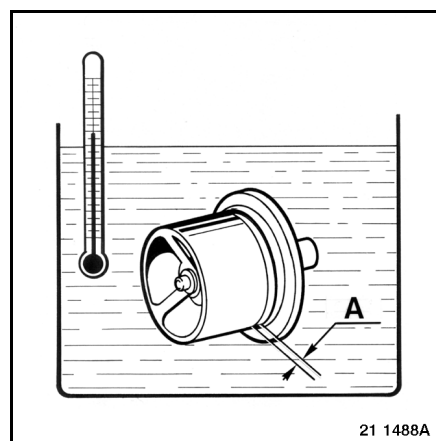

Assembly

Install seal (10).
Lubricate the outside of the seal with soapy water.
Fit coolant pump (9).
Match the direction of orientation.

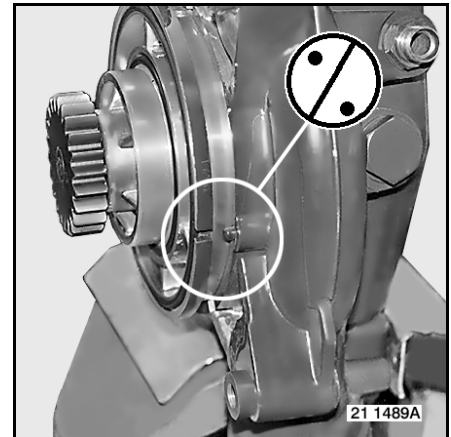

Fit seal ring (6).
Match the direction of orientation.
Use tool 3016 + 2363 Ø 68 mm.
Fit thermostat (5).

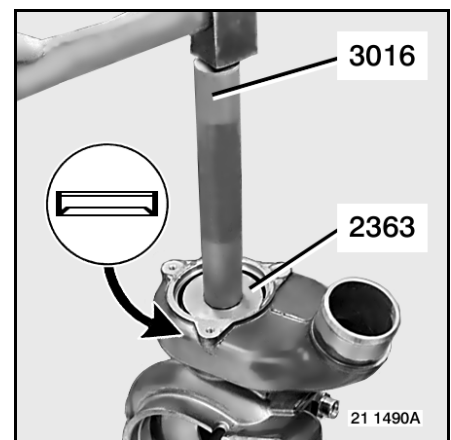

Fitting

Install seals (7 - 8).

Fit the assembly (9 - 11)

Fit setscrews.

Ensure a seal with "FRENETANCH 242" oiltight compound.

Tighten to torque.

See page B-2-5

Install seal (12) to pipe (18).

Lubricate the outside of the seal (12) with soapy water.

Fit pipe (18).

Fit clamp (14).

Fit support (13).

Fit setscrews.

Tighten to torque.

See page B-2-2

Install seal (17).

Lubricate the inside of the seal (17) with soapy water.

Fit flange (16).

Install O-ring (15).

Install seal (12) to pipe (19).

Lubricate the outside of the seal (12) with soapy water.

Fit pipe (19).



Fasten the clip to the heat exchanger before tightening the water pump clip.

Tighten to torque.

See page B-2-2

Install O-rings (1 - 3).

Fit sleeve (4).

Fit the assembly (2 - 4)

Tighten to torque.

See page B-2-2

INJECTION

Generalities

Description of system

"COMMON RAIL" electronic fuel-injection system components:

- Electronic control unit (ECU) (1)
- ECU cooler (2)
- Fuel hand priming pump and prefilter (3)
- Booster pump (4)
- Fuel filters (5)
- Fuel metering housing (6)
- Scavenge valve (7)
- Fuel flow regulation solenoid valves (8)
- High pressure pump (9)
- Common rail (10)
- Rail pressure limiter (11)
- Fuel injectors (13)
- Rail pressure sensor (14)
- Flywheel speed sensor (20)
- High pressure pump speed sensor (21)
- Flow limiters (12)
- Cooling circuit temperature sensor (17)
- Boost air pressure and temperature sensor (19)
- Engine oil level sensor (18)
- Engine oil pressure sensor (15)
- Engine oil temperature sensor (16)*
- engine stop control (cab tilted) (23)*
- Accelerator pedal (24)
- Fuel tank (29)
- Alert warning light (25)
- Fuel filters clogging sensor (30)*

Auxiliary functions components

- Declutching fan clutch (22)*
- Exhaust brake and Jake engine-brake (28)

Information delivered by sensors common to several functions

These information items are collected by vehicle management ECU (26), which sends them to the different peripheral systems ECUs and to the engine ECU in digital form via "CAN BUS" (27).

Examples:

- Engine temperature, oil pressure...
- Tachograph speed information
- Accelerator pedal position sensor (24) information
- PTO information
- Braking information
- Engine immobilizer information

Hydraulic circuits:

- (A): Aspiration
- (B): Low pressure
- (C): High pressure
- (D): Leak-off return to fuel tank



For work on the engine wiring harness, use tool 2589

dCi 11 B43

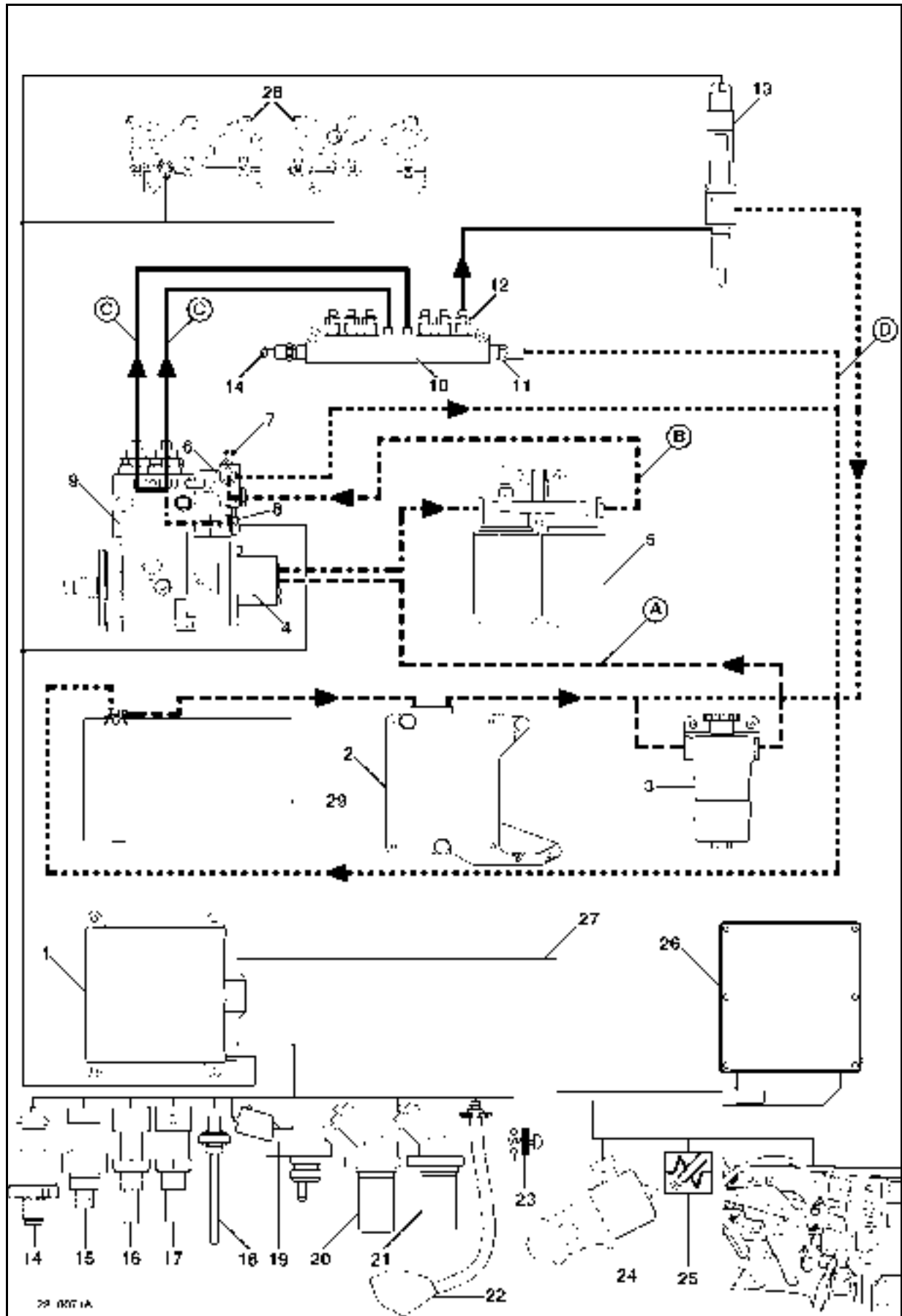

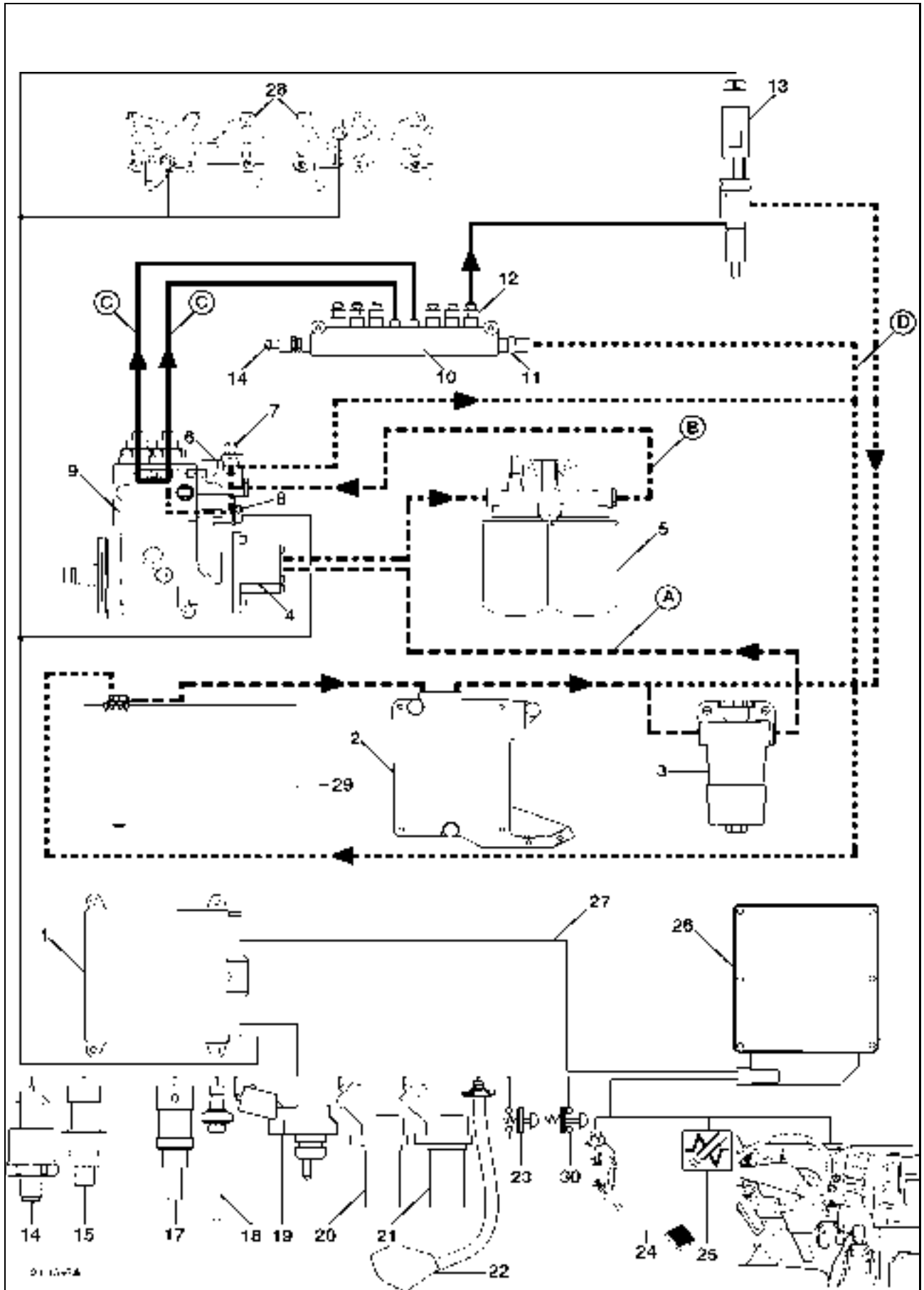

Operation of the system

The new pollutant emissions and harmful noise standards and the research into controlling vehicle operating costs have led to the advent of more precise and more sophisticated fuel-injection systems in the matter of environmental protection and specific fuel consumption.

To meet these requirements, the "COMMON RAIL" fuel-injection system operates according to the following principles:

- High pressure variable according to engine needs independent of load and rotating speed,
- Timing variable according to engine needs independent of load and rotating speed,
- Pressure-time type fuel metering,
- Pre-injection if required (to reduce engine knock),
- Multi-point injection managed integrally by onboard electronics.

Fuel metering and injection:

The fuel stored in the fuel tank is aspirated by the booster pump and sent at low pressure to the high pressure pump inlet. The high pressure value (200 to 1400 bars) is determined by the amount of fuel taken in by the high pressure pump. This quantity is piloted by flow regulation solenoid valves located in the metering housing. The fuel is directed to the common rail, then distributed to the injectors whose opening is controlled electrically by the ECU. The flow limiters forbid leaks in the high pressure circuit downstream from the rail in the event of component fracture (pipe...) and protect the engine in the event of injector malfunction.

To manage the system, the ECU receives information from:

- vehicle electronic control unit "VECU",
- common rail pressure sensor,
- flywheel and high pressure pump speed sensors,
- cooling circuit temperature sensor,
- engine oil temperature sensor,
- accelerator pedal,
- boost air pressure and temperature sensor,
- declutching fan speed sensor,
- cruise control and idling adjustment control.

Functions ancillary to the "COMMON RAIL" system:

- Engine cooling management,
- Cruise control,
- Engine immobilizer,
- Engine protection (overheating, torque limitation),
- Exhaust brake management,
- Adjustable idling variable according to conditions (air conditioning, engine temperature),
- Fast idling adjustable from the driving position.

Operation in fall-back mode

Detected faults change the features provided by the system to fall-back mode, the effects of which are felt more or less while driving:

- cutting of maximum rail pressure (several levels),
- longer starting time,
- stopping of operation of retarder,
- modification to cooling fan pilot-control,
- stopping of operation of one or several injectors,
- etc...

Depending on the gravity of the fault, the consequences might be negligible (e.g. an engine speed sensor) or seriously affect the features provided by the system, which may go as far as forbidding starting. With the aim of minimum vehicle lay-up, in the event of not too serious a fault, the ECU functions by approximate calculation on the basis of values that are still available or by means of values contained in the mapping.



Whatever the fault, it is absolutely essential to get the system overhauled as soon as possible.

Layout of components on-vehicle

Fuel aspiration circuit

- ECU cooler (1)
- Injectors aspiration and leak-off return pipe
- Fuel hand priming pump and prefilter (3)
- Rail leak-off return pipe (4)

Low pressure (boosting) circuit

- Booster pump (5)
- Low pressure pipes (6)
- Fuel filter(s) (7)
- Scavenge valve (8)
- Fuel metering housing (9)

High pressure circuit

- High pressure pump (10)
- Rail delivery pipe gallery (11)
- Common rail (12)
- Rail pressure limiter (13)
- Flow limiters (14)
- Injector pipes gallery (15)
- Cylinder head fuel delivery pipe (16)
- Injection pilot-control solenoid valve (9220 / 9221 / 9222 / 9223 / 9224 / 9225)

Electrical components

- Engine electronic control unit (EECU) (9202)
- N° 1 cylinder high pressure pump solenoid valve (9213)
- N° 2 cylinder high pressure pump solenoid valve (9212)
- Fuel high pressure sensor (9208)
- Flywheel speed sensor (9228)
- Pump (injection or high pressure) speed sensor (9262)
- Engine coolant circuit temperature sensor (7362)
- Engine oil temperature sensor (9226)
- Boost air pressure and temperature sensor (9200)
- Engine oil level sensor (8275)
- Engine stop control (cab tilted) (2266)*
- Engine oil pressure sensor (7368)
- Fuel filters clogging sensor (2400) (18)
- Engine wiring harness (17)

Ancillary functions components

- Declutching fan (8228)*
- Exhaust brake electrovalve (8150)
- Jake brake solenoid valve N° (7940)
- Jake brake solenoid valve N° 2 (7941)
- Vehicle electronic control unit (VECU) (9201)
- Diagnostics socket (7519)

Driver interface

- Accelerator pedal position sensor (5266)
- Steering wheel fingertip controls (cruise control) (6167)
- "DANGER" immediate stop warning lamp (7521)
- "SERVICE" warning lamp (7522)
- Engine electronic fault warning lamp (9267)
- Vehicle electronic fault warning lamp (9268)

dCi 11 B43

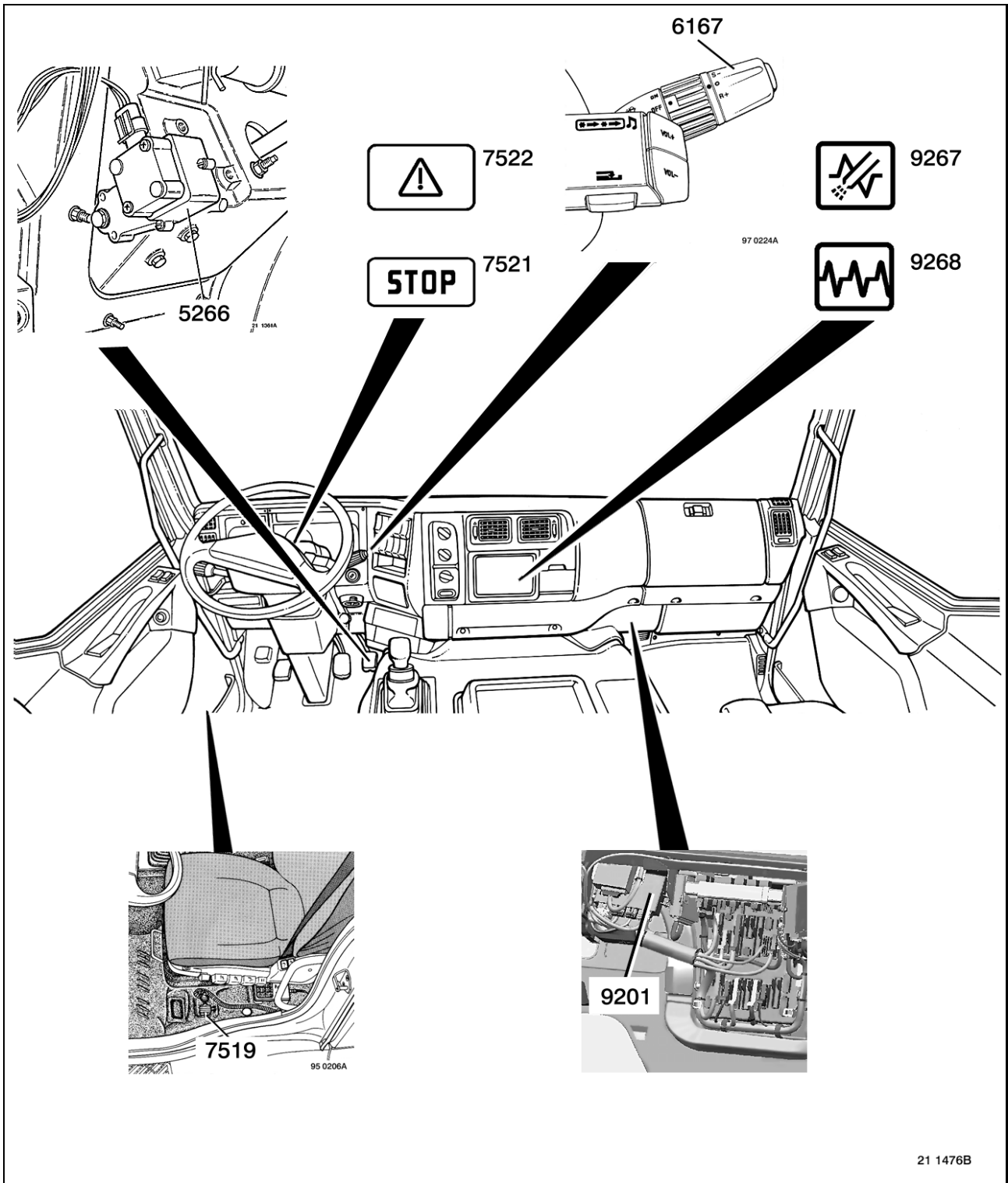

dCi 11 +J01

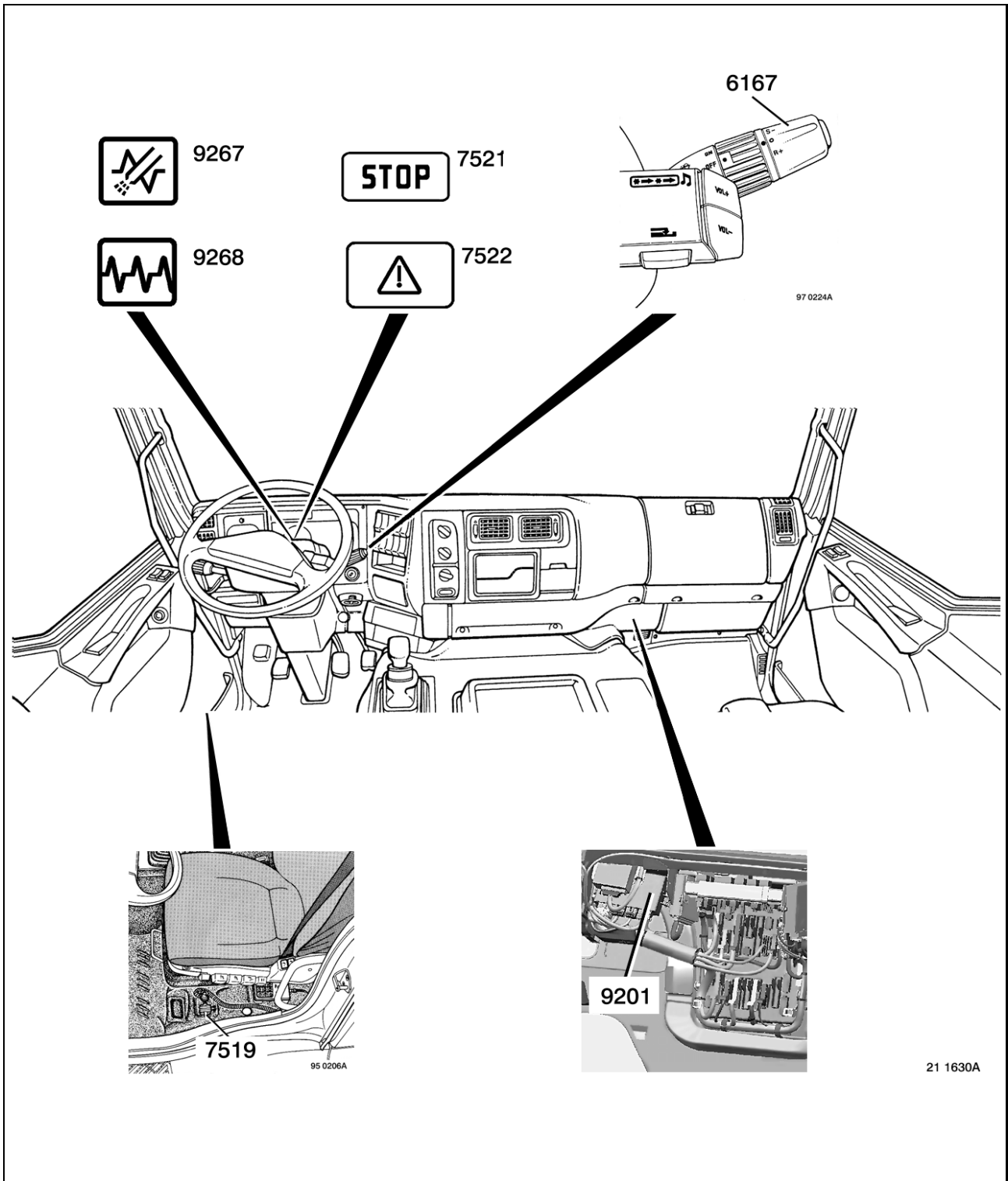

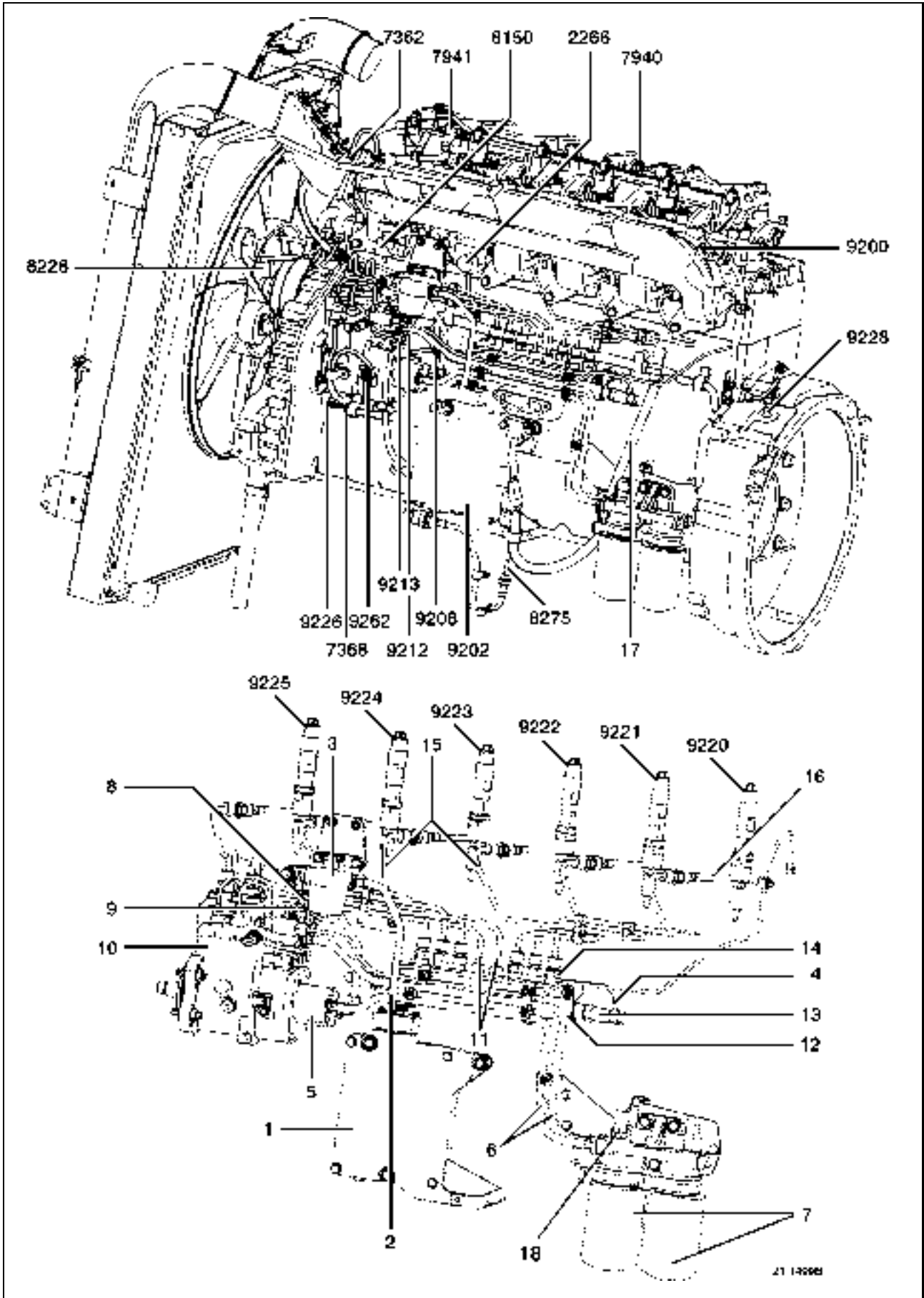

Technical data

Engine master electronic control unit (EECU)

The EECU receives information from the sensors and the vehicle electronic control unit (VECU). Depending on the input data, it pilot-controls fuel-injection and certain ancillary functions (engine cooling fan, retarder, fast idling).

It informs the driver of the status of the system by means of instrument panel tell-tale lights and, in the event of fault, operates in fall-back mode or emergency mode (refer to the "Diagnostics" chapter).

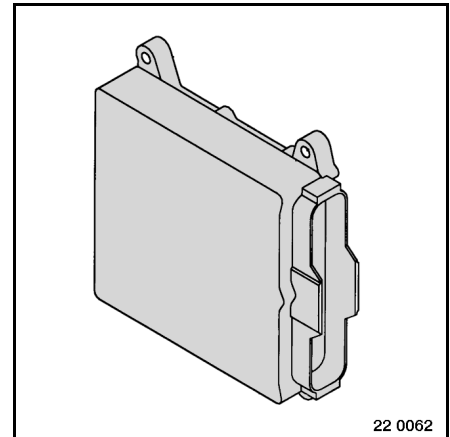

ECU cooler

The ECU cooler is fastened to the engine block on rubber sandwich mountings and damps vibrations while supporting the ECU.

It dissipates the heat energy given off by the engine and by the electrical current (injectors control) crossing the ECU.

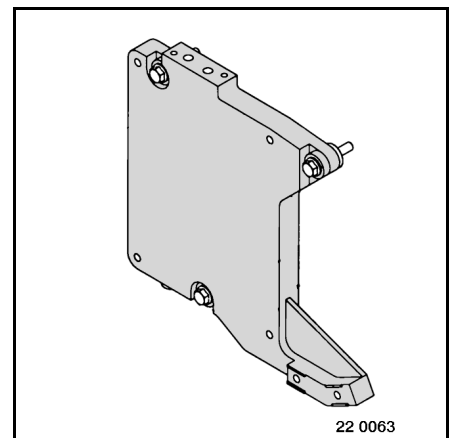

Fuel hand priming pump and prefilter

The fuel priming pump incorporates a gauze prefilter that can be washed in diesel fuel.

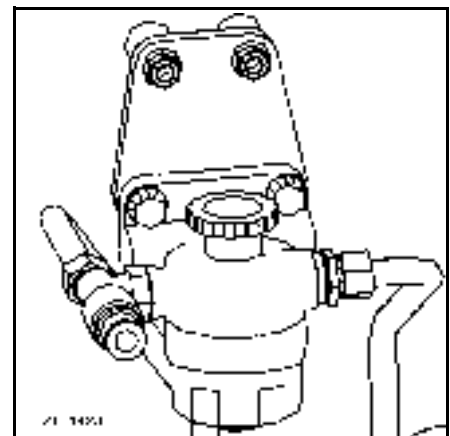

Fuel filters

(1): bleed screw and low pressure take-off.

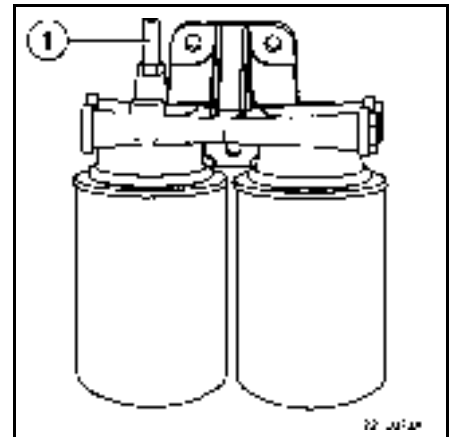

The oil filters, owing to their capacity and their specific filtration level, must be replaced only by filters approved by RENAULT TRUCKS. Upon fitting, do not fill the cartridges.

Booster pump

The booster pump is of the gear type. It is fastened to the high pressure pump casing.

The booster pump cannot be repaired.

Output: up to **500 litres/hour**.

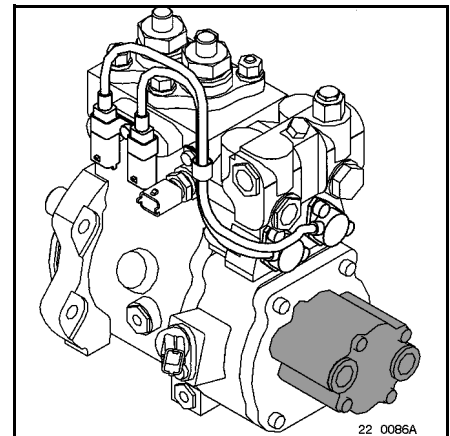

Scavenge valve

The scavenge valve keeps the low pressure circuit pressure to values between **4 and 5 bars** at idling and between **6 and 7 bars** at an engine speed of **2000 rpm**.

The valve calibration value should be between **1.8 bars** and **2.2 bars**.

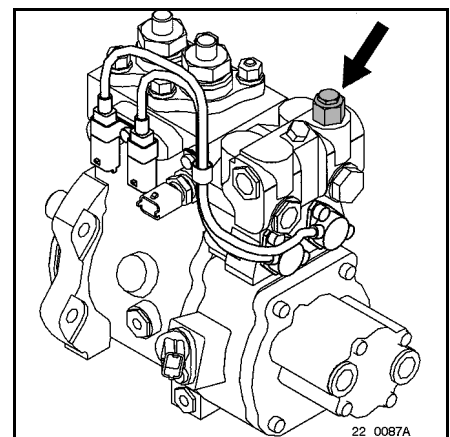

Fuel metering housing

The fuel metering housing integrates the two fuel flow regulation solenoid valves. These valves each pilot-control a shuttle valve that manages the fuel flowrate to the high pressure pump inlet. The metering housing cannot be repaired.

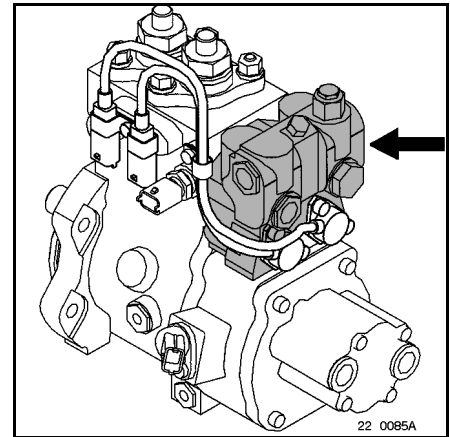

Fuel flow regulation solenoid valves

The two fuel flow regulation solenoid valves are mounted on the fuel metering housing. Their job is to adjust the fuel flow so as to maintain the pressure in the rail at the required value. Without electrical supply, the solenoid valves are in the "normally-closed" position (maximum rail pressure).

- 1: solenoid valve N° 1
- 2: solenoid valve N° 2

Résistance: **15 Ω**

In the event of solenoid valve failure, replace the high pressure pump.

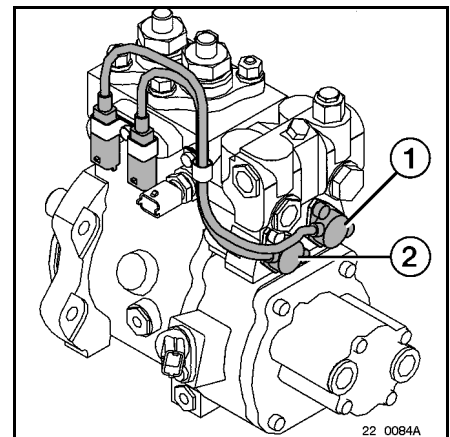

High pressure pump

The high pressure pump consists of two pumping elements. The pistons are controlled by a camshaft. The high pressure pump cannot be repaired.

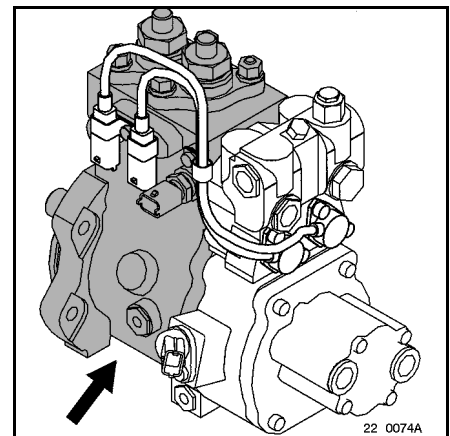

Common rail

The common rail provides the link between the high pressure pump and the fuel injectors.

The rail is equipped with:

- a pressure sensor,
- flow limiters,
- a pressure limiter.

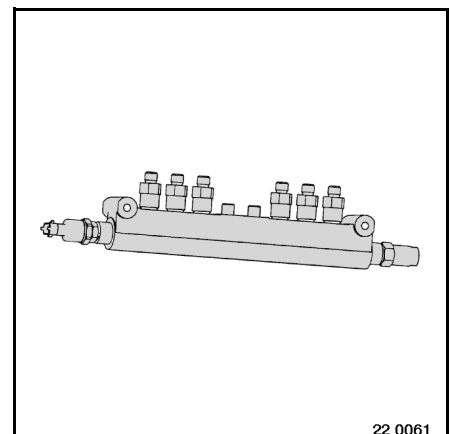

Rail pressure limiter

The pressure limiter protects the high pressure circuit against any excessively high pressure due to by-pass of fuel to the leak-off return circuit (e.g.: failure of a fuel flow regulation solenoid valve). If such occurs, it is essential to replace the rail pressure limiter.
Limiter calibration: **1650 ± 50 bars**.

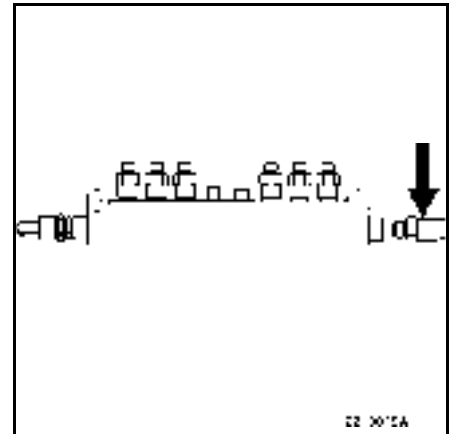

Fuel high pressure sensor

The rail pressure sensor is of the piezo-resistive type. Supplied with 5 Volts current, it delivers an output current (0.5 to 4.5 V) as a function of the measured pressure value. This value is sent to the ECU.

The sensor can only be fully tested using the RENAULT TRUCKS DIAGNOSTICA test tool.

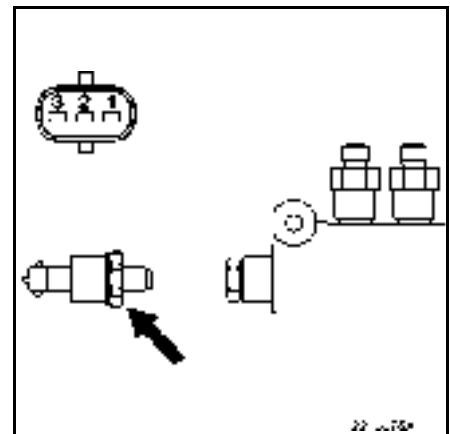

Flow limiter

Flow limiters are fitted to each rail outlet. They isolate a section of the high pressure circuit in the event of too high a flowrate or in case of continuous leak-off (fracture of injector pipe, injector malfunction, etc.).

Maximum flow without jamming the limiter: **600 mm³/shot**.

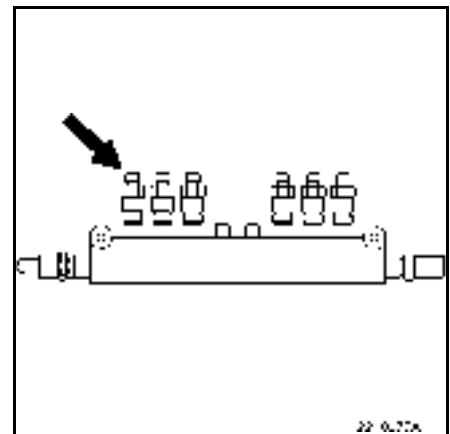

Fuel injector / nozzle-holder

Each unit consists of a solenoid valve fitted to the nozzle-holder that controls opening and closing of the injector. Fuel injector / nozzle-holder units cannot be repaired. All seals must be replaced without fail each time the unit is removed.

Solenoid valve resistance: **0.33 Ω at 20°C**.

Non-polarized terminals.

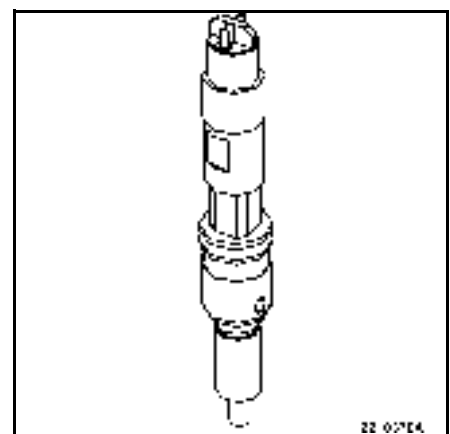

Accelerator pedal position sensor*

The accelerator pedal position sensor consists of a double-track rheostat bridge and a position switch contact.

Fixed resistance: **2300 Ω** between terminals N° 1 and N° 6.

Rheostat tracks (as a function of acceleration):

- between terminals N° 1 and N° 3, the resistance rises gradually from around **400 Ω \rightarrow 1800 Ω ,**
- between terminals N° 1 and N° 3, the resistance falls gradually from around **1800 Ω \rightarrow 400 Ω .**

The contact is closed between terminals N° 2 and N° 5 when the acceleration travel is less than **17 %**.

The sensor can only be fully adjusted using the RENAULT TRUCKS test tool DIAGNOSTICA.

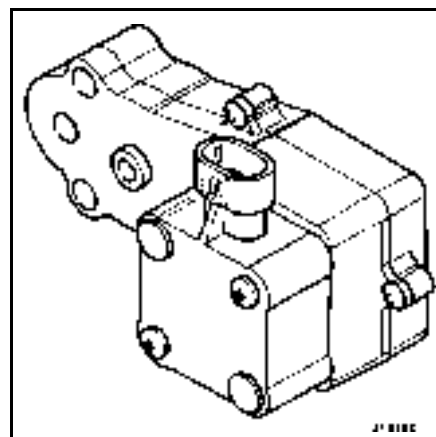

Accelerator pedal

The sensor can only be fully tested using the RENAULT TRUCKS DIAGNOSTICA test tool.

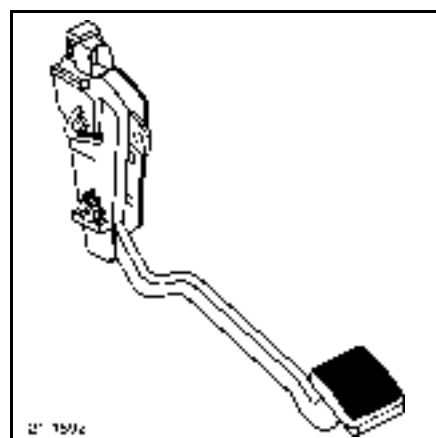

Cylinder head delivery pipes

The cylinder head delivery pipes are provided with a built-in fuel filter and a rotational immobilization device comprising two balls.

These parts, complete with seals, must be replaced without fail each time the unit is removed.

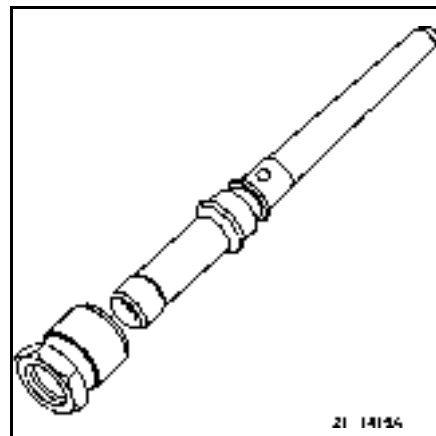

Speed sensors

The speed sensors are of the inductive type and deliver a sinusoidal voltage generated by passage of the flywheel notches and the pump toothed wheel. The frequency of this signal is proportional to the engine rotating speed.

The flywheel is provided with **58 notches (60 - 2)**. The two missing notches indicate the top dead centre position of N° 1 cylinder.

The pump toothed wheel is provided with **7 teeth** (one tooth per top dead centre of each cylinder and two side-by-side teeth for the top dead centre of N° 1 cylinder).

Sensor resistance: **770 \rightarrow 950 Ω** at 20°C.

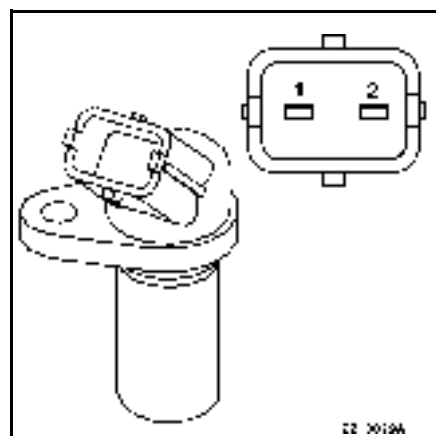

Engine cooling circuit temperature sensor**Engine oil temperature sensor**

The sensors are of the CTN thermistance type

Characteristics:

Temperature (°C)	Resistance (Ω)
-20	17 700 → 13 500
-10	10 650 → 8 250
0	6 650 → 5 200
20	2 800 → 2 200
30	1 860 → 1 550
40	1 300 → 1 000
60	640 → 550
80	300 → 200
100	200 → 170

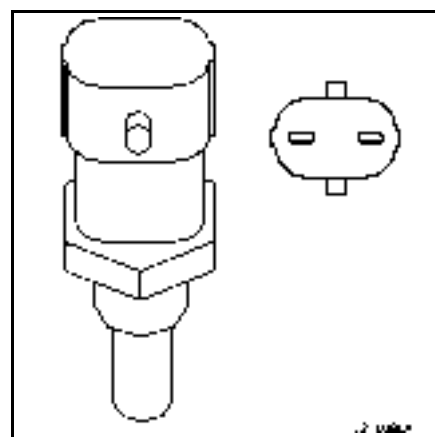
**Boost air pressure and temperature sensor**

The single boost air pressure and temperature sensor incorporates two measuring elements and is mounted on the intake manifold:

- A pressure sensor of the piezo-resistive type:
 - supplied with 5 Volts current, it delivers an output current of between 0.5 to 4.5 Volts.
- A temperature sensor of the CTN thermistance type.
 - Characteristics (between terminals N° 1 and N° 2).

Temperature (°C)	Resistance (Ω)
0	6 600 → 5 900
10	4 200 → 3 800
20	2 760 → 2 500
30	1 870 → 1 700
40	1 280 → 1 180
50	900 → 830

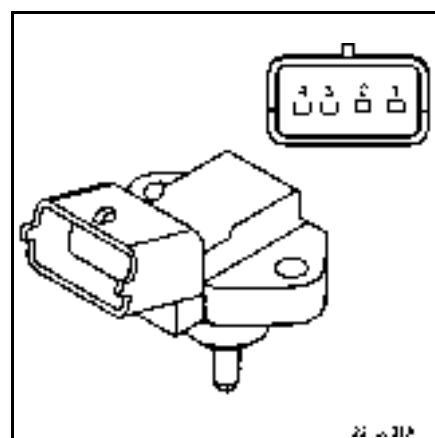
**Engine oil pressure sensor**

The engine oil pressure sensor is of the piezo-resistive type: supplied with 5 Volts current, it delivers an output current of 5 Volts as a function of the engine oil circuit pressure (0 to 7 bars).

The sensor can only be fully tested using the RENAULT TRUCKS DIAGNOSTICA test tool.

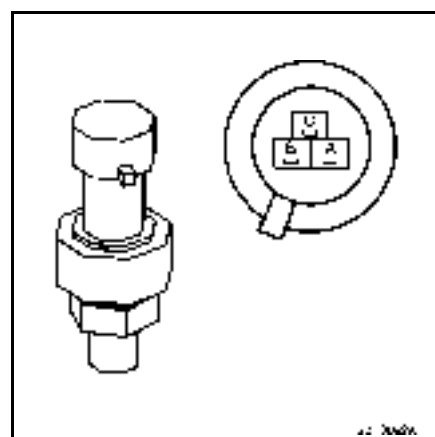

Engine oil level sensor

The engine oil level sensor features a thermo-resistive heating wire. It is supplied by the ECU. The rise in temperature of the wire and therefore the change in its resistance allows the ECU to define the engine oil level.

Characteristics:

Temperature (°C)	Resistance (Ω)
-30	9.3
20	11.4
150	16.7

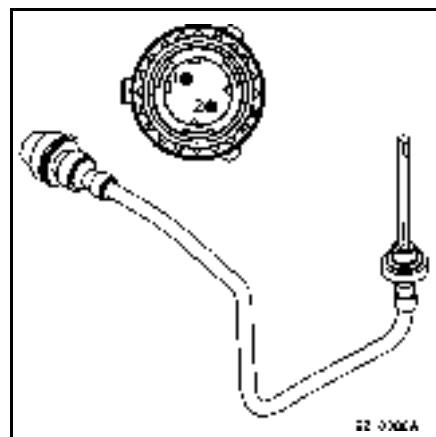

Engine stop control*

The engine stop control is a switch with normally-open contacts that serves to shut down the engine when the cab is raised (normally-open for EURO 2).

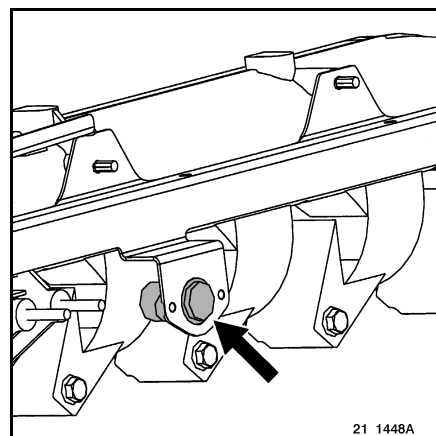

Diagnostics socket

The diagnostics socket allows the "COMMON RAIL" system to communicate with the RENAULT TRUCKS diagnostics tool for the purpose of full diagnostics and parameter definition.

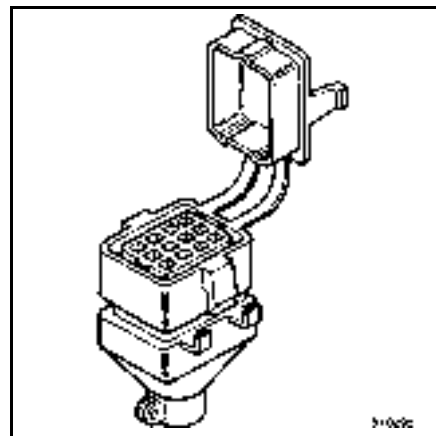

Declutching fan clutch*

The engine cooling fan clutch is a unit comprising a rotating speed sensor, a pilot-control solenoid valve and a viscous coupling. The ECU pilot-controls the viscous coupling via the solenoid valve as a function of engine needs (temperature, fall-back mode, operation of air conditioner).

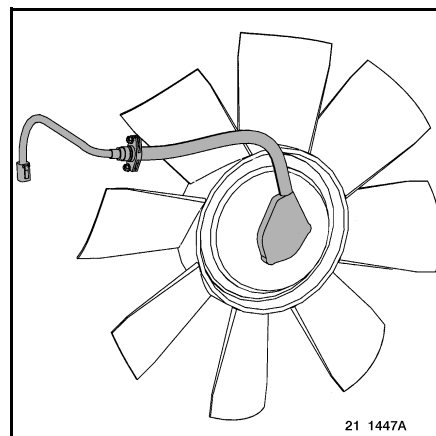

Fuel filters clogging sensor

This sensor is a switch with normally-closed contacts. It changes state when the pressure difference between P1 (1) and P2 (2) is around **3 bars**.

The clogged filters information is time-delayed and is sent to the display only when the engine is at its operating temperature. This is to avoid the appearance of faults due to pressure peaks or to diesel fuel that is frozen in very cold weather.

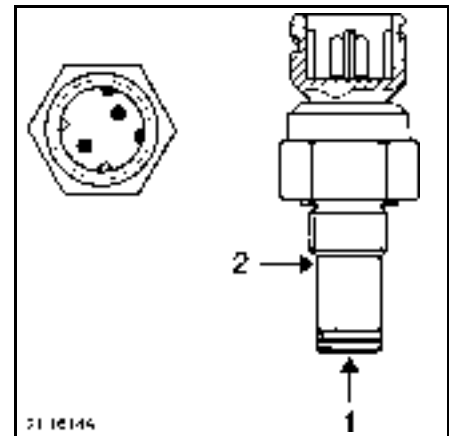

Repair

Precautions

The "COMMON RAIL" system is a high-performance fuel-injection system

Since this system is more sensitive to cleanliness than in-line injection pump systems, risks of damage are all the more important. Hence, it is essential to comply with the fitting of genuine spare parts guaranteed by the manufacturer and observe operating, maintenance and repair instructions for the system.

Work on the "COMMON RAIL" system

The system works with very high injection pressures (up to **1400 bars**) and with medium voltage current (control of injectors by discharge of capacitors).

Prior to dismantling, carefully clean the surrounds then take all necessary precautions to prevent the ingress of foreign matter. Use a clean thinner then blow through with compressed air.

Using the RENAULT TRUCKS test tool DIAGNOSTICA, ensure that the circuit pressure has dropped completely.

In fact, under normal operating condition, the pressure drops rapidly in the high pressure circuit after the vehicle has stopped (between 1 & 3 minutes). In extreme cases of malfunction (several or all the flow limiters jammed) high pressure may prevail for a long time, even not drop. In such case, create a fuel leak by loosening an injector pipe union while protecting your hand and keeping it as far away as possible from the point of leak.

Any work on the fuel-injection system must be carried out with the engine shut-down (check: injectors, voltage, resistance, tightening, etc.).

Repairs must be carried out in a clean room, free from dust and using suitable tools.

The wearing of gloves made from fibrous material is to be banned.

Carefully clean the parts with a clean solvent, then inspect. Use top quality small brushes that are perfectly clean and in very good condition. Use unsoiled lint-free cloths.

The spare parts department supplies cleaning cloths, blanking plugs and storage bags suitable for one-way use. Blank off the ports with plugs as soon as the pipes are dismantled.

Avoid using compressed air.

Cleaned components must be protected to avoid any trace of corrosion in the circuit.

The injector nozzle-holder cannot be repaired. Systematically replace the unit in the event of malfunction.

Do not expose yourself to sprayed fuel when testing injector sprays or high pressure circuit dribble.

Follow the chronological disassembly / assembly sequence outlined in the workshop manual.

Reassembly must be carried out without any modification or stress (torsion, welding, distortion, connecting arrangement, fastening, routing, etc...). Replace the part, if necessary. Tighten to the recommended torque.

Circuits are to be bled without using the starter.

All these recommendations guarantee you "COMMON RAIL" system quality and reliability.

New pipes

The inside of the gallery pipes is protected by a rust-inhibitive product.

The walls are greasy and easily retain dust.

The pipes must be rinsed with solvent or industrial alcohol then fitted immediately (risk of oxidation).

Bleeding the fuel circuit

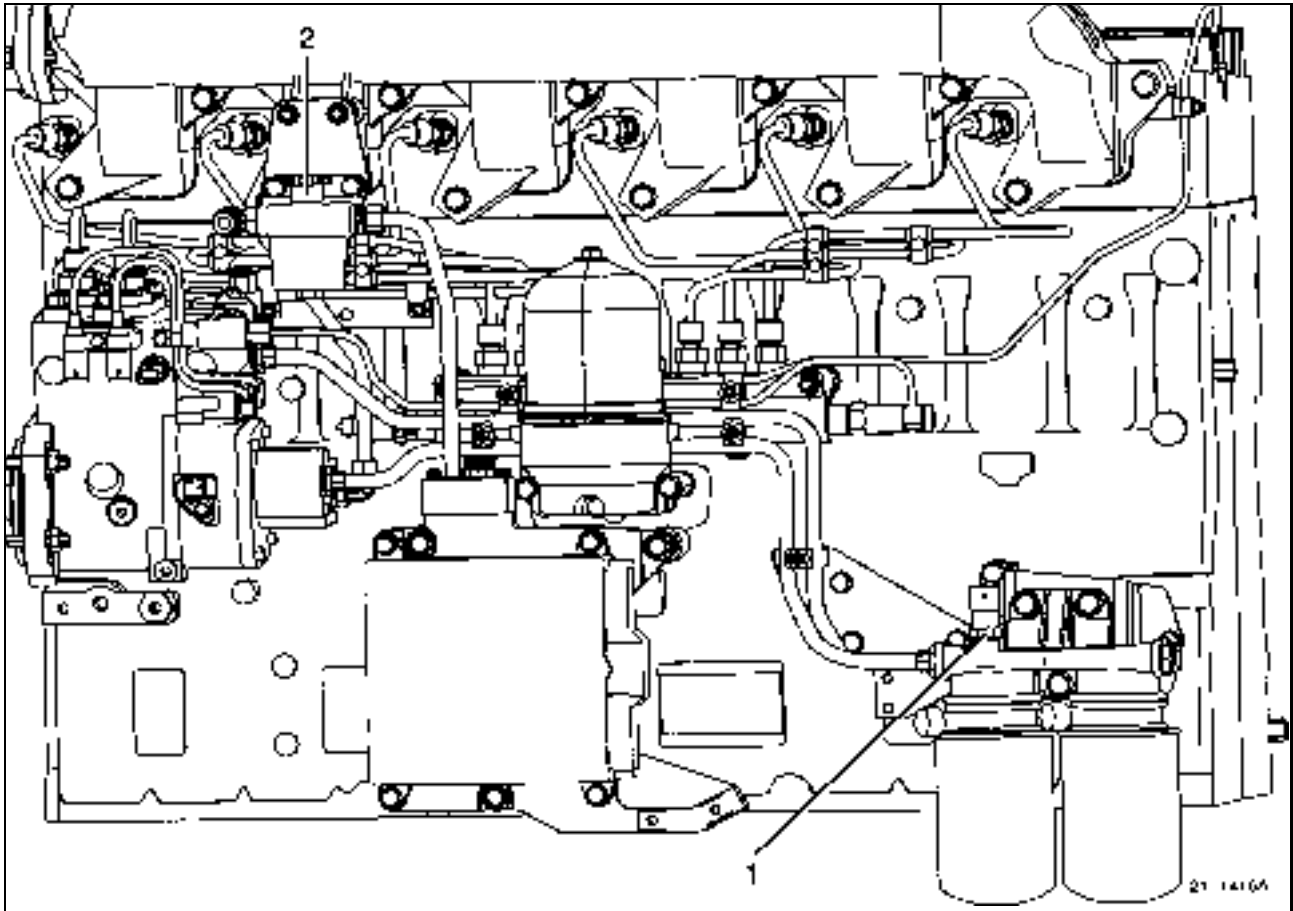

Open bleed screw (1), then unscrew and actuate hand pump (2) until the fuel flows without air bubbles. Close the bleed screw and actuate the hand pump until it hardens. Screw up the hand pump control before starting the engine.

Actuate the starter until the engine fires.



It is forbidden to bleed the low pressure circuit using the starter.

Fuel hand priming pump and prefilter

Removal

Unscrew unions (1).
 Hold unions (2) while loosening unions (1).
 Remove setscrews (3).
 Watch out not to bend the pipes.
 Remove the hand priming pump.

Fitting

For fitting, proceed in the reverse sequence to removal.
 Tighten unions (1) to torque.

See page B-2-7

Hold unions (2) while tightening unions (1).

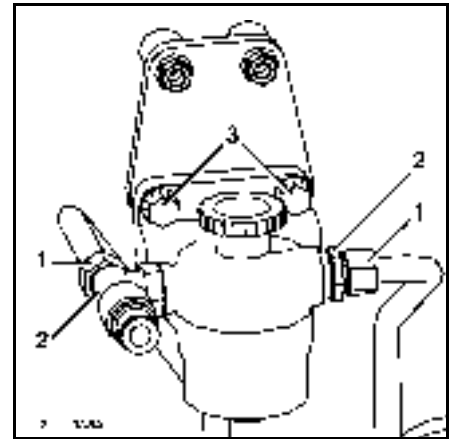

Checking the fuel pressure (low pressure circuit)

Ensure that the filter is in good condition.
 Use tool 2648 + 1246
 Slightly loosen the bleed screw (1).
 Pressure values (see page J-1-11) (scavenge valve)

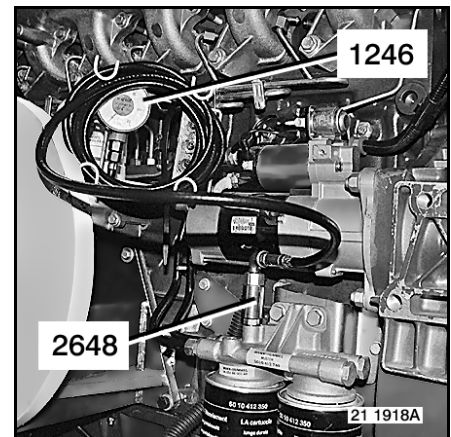

Common rail delivery pipe gallery

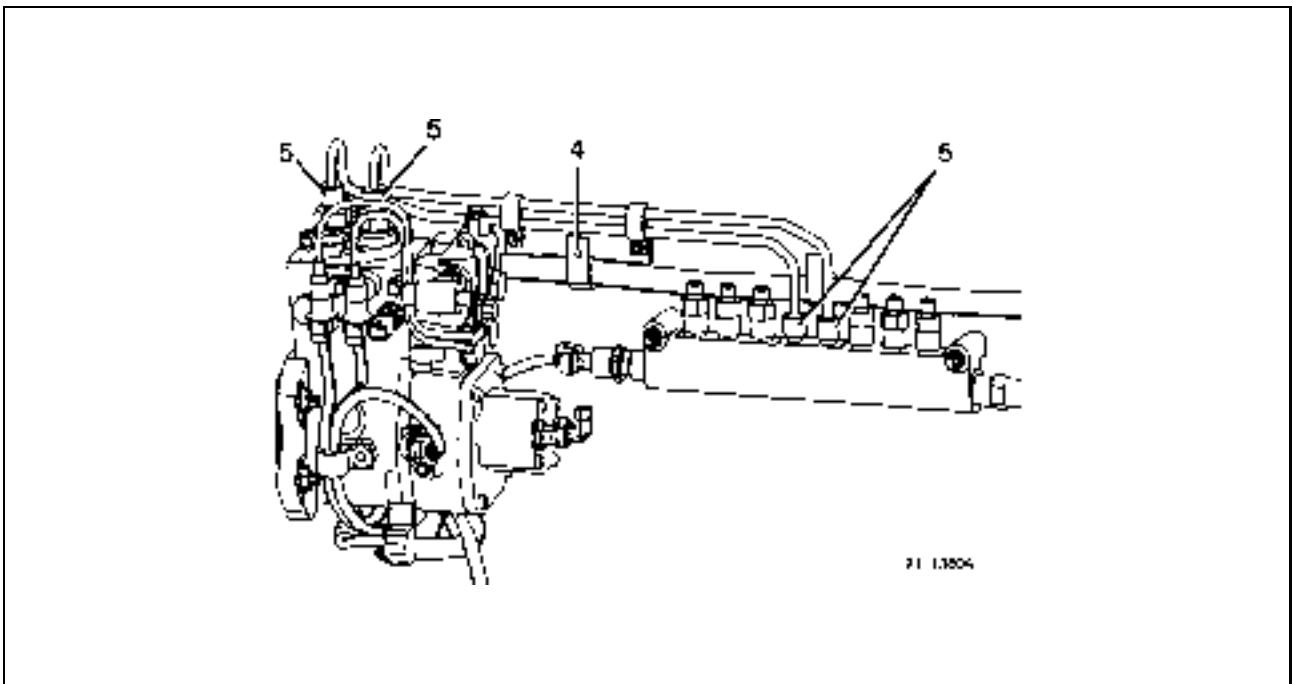
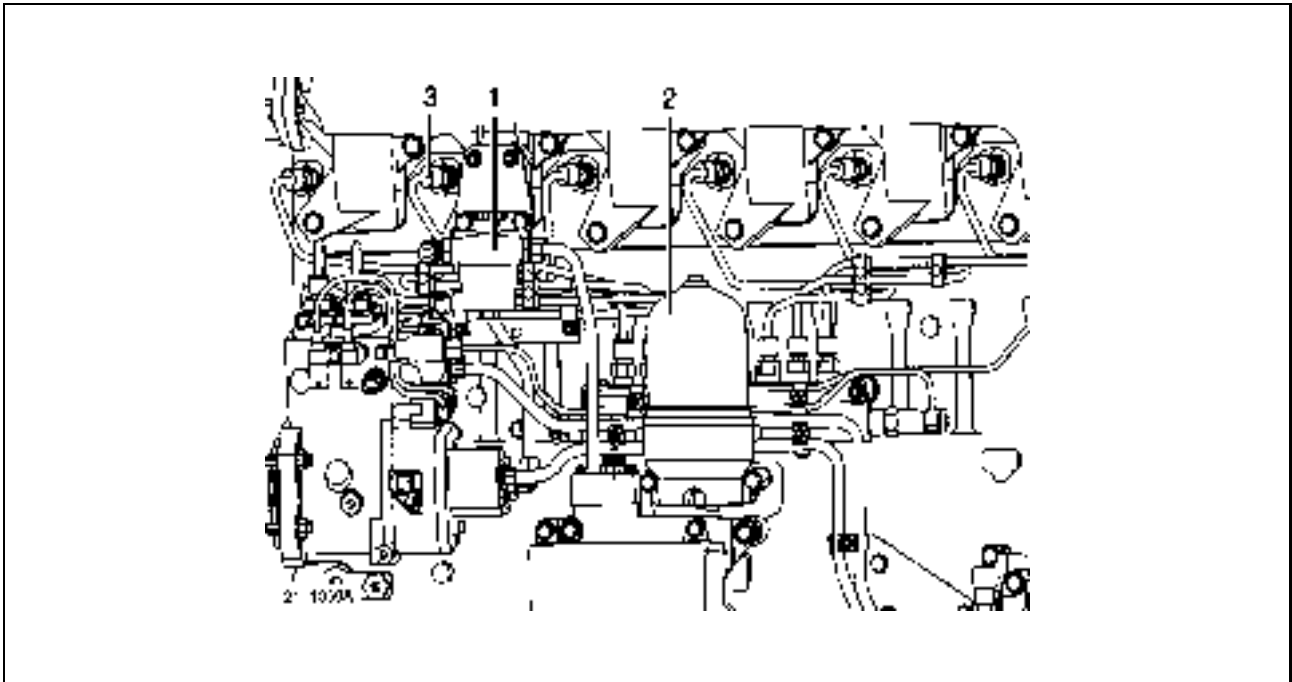

To remove and fit the other components quoted in the paragraph, refer to their respective chapter. The pipe gallery forms an element that cannot be disassembled. The pipes are positioned between one another and in relation to the fastening clamp. It is strictly forbidden to modify the gallery, the clamp fastening or the position of the pipes.

Removal

Remove hand priming pump and prefilter (1)*.

See page J-2-4

Remove centrifugal filter (2).

See page J-2-4

Remove N° 4 / 5 / 6 cylinder injectors pipe gallery.

Remove setscrew (4).

Loosen unions (5).

Remove the pipe gallery from the common rail.

Blank off the ports.

Put each part in a new watertight plastic bag immediately after its removal.

Fitting

It is absolutely essential to follow the pipe gallery assembly procedure detailed below.

Install the pipe gallery to the engine.

Screw up setscrew (4) securing the bracket, without tightening.

If necessary, exert a force on the pipes by hand to bring the pipe unions into position on the high pressure pump and common rail unions. A 5 mm maximum vertical and horizontal displacement of the unions is permitted due to torsion of the pipes.

Use of a lever arm is forbidden.

Screw up pipe unions (5) without tightening.

Tighten bracket securing screw (4) to torque.

Tighten unions (5) to a torque of **40 Nm**.

Use tool **2565**.

In the event of leakage at a nut, loosen the nut in question by 1/4 of a turn, then retighten at a maximum torque of **50 Nm**. **If the leak persists, the pipe gallery must be replaced.**



It is essential to replace the complete pipe gallery. Under no circumstance should the flanges connecting the pipes in the same gallery be dismantled.

Injector pipe gallery

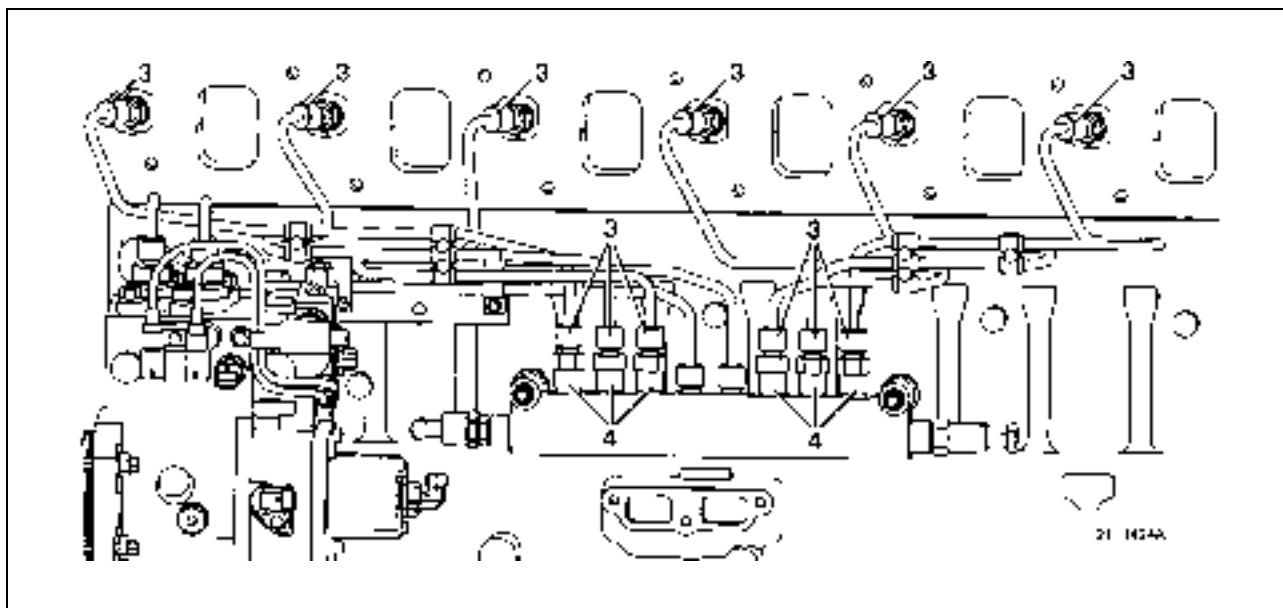

To remove and fit the other components quoted in the paragraph, refer to their respective chapters.

Removal

Remove hand priming pump and prefilter (1)*.

See page J-2-4

Remove centrifugal filter (2).

See page J-2-4

Loosen unions (3).

Check that the cylinder head fuel delivery pipes remain fastened during the unions (3) tightening phase. If they turn around, it is essential to replace them.

While loosening the rail end unions, hold the flow limiters (4) to prevent them from working loose.

Remove pipes gallery.

Blank off the ports.

Put each part in a new watertight plastic bag immediately after its removal.

Fitting

For fitting, proceed in the reverse sequence to removal.

Tighten pipe unions (3) to a torque of **40 Nm**, without holding flow limiters (4).

Use tool **2565**.

In the event of leakage at a nut, loosen the nut in question by 1/4 of a turn, then retighten at a maximum torque of **50 Nm**. **If the leak persists, the pipe gallery must be replaced.**

Check that the cylinder head fuel delivery pipes remain fastened during the unions (3) tightening phase. If they turn around, it is essential to replace them.



It is essential to replace the complete pipe gallery. Under no circumstance should the flanges connecting the pipes in the same gallery be dismantled.

Accelerator pedal position sensor (dCi 11 B43)

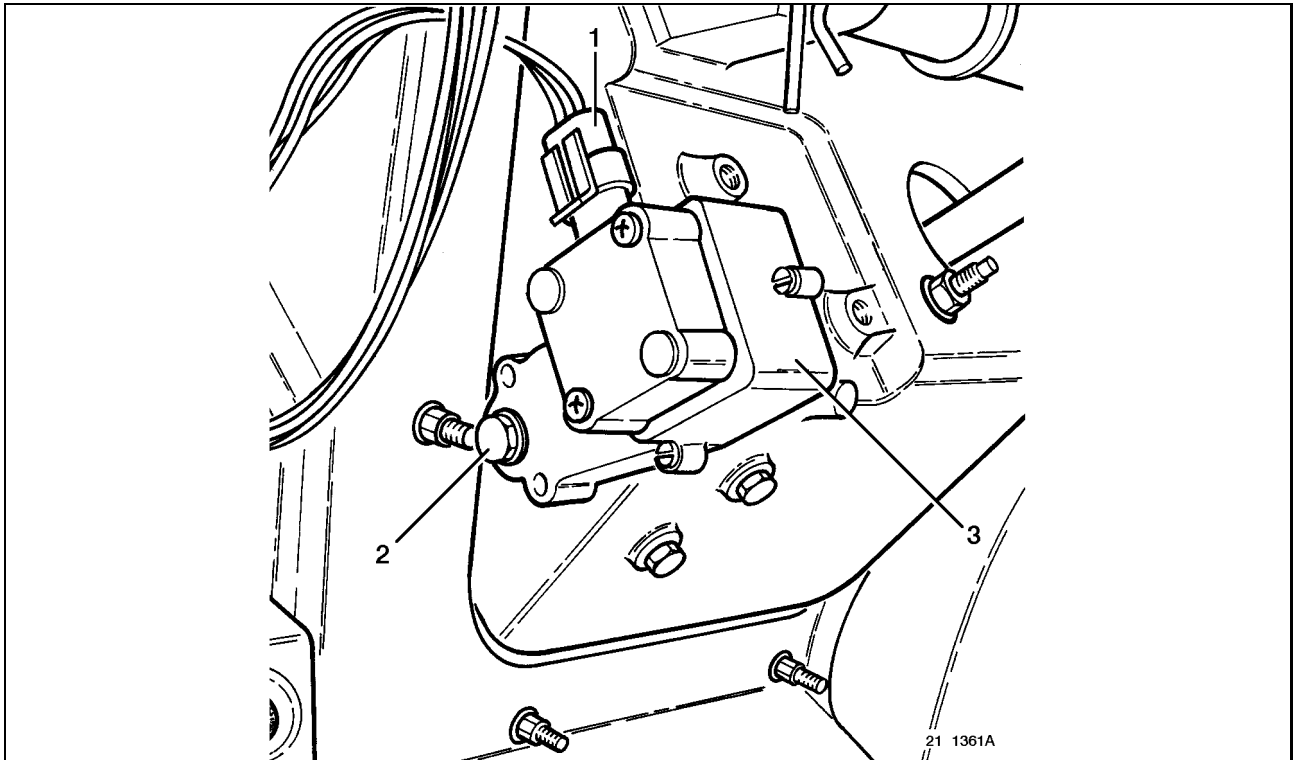

Removal

- Remove the steering column trim.
- Unplug connector (1).
- Remove setscrew (2).
- Remove sensor (3).

Fitting

- To fit, proceed in the reverse sequence to removal.
 - It is essential to tighten setbolt (2) to the recommended torque.
- See page B-2-6**

Accelerator pedal (dCi 11 B43)

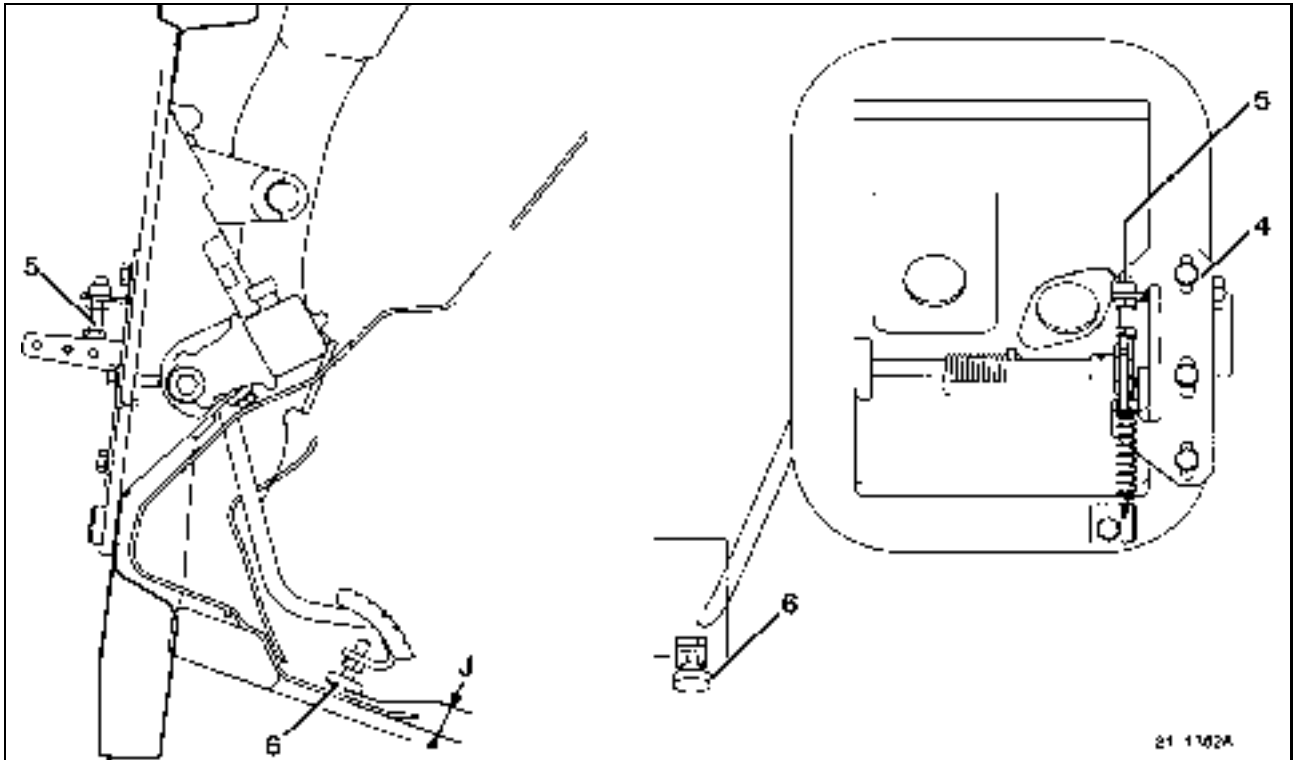

Adjustment

The sensor is adjusted by altering the respective positions of the adjusting stops (**4 - 5**) to change the high and low position of the accelerator pedal.

Measure the voltage delivered by the sensor using the RENAULT TRUCKS diagnostics tool.

Alter the position of adjusting stops so as to obtain the following voltages (**U**):

- pedal "up": **$0.75 < U < 0.9$ Volt.**
- pedal fully depressed (press the pedal in the cab): **$3.75 < U < 3.9$ Volts.**

Alter the position of stop (**6**) to obtain a clearance **$J < 5$ mm** when the pedal is fully depressed.

Accelerator pedal (dCi 11 + J01)*

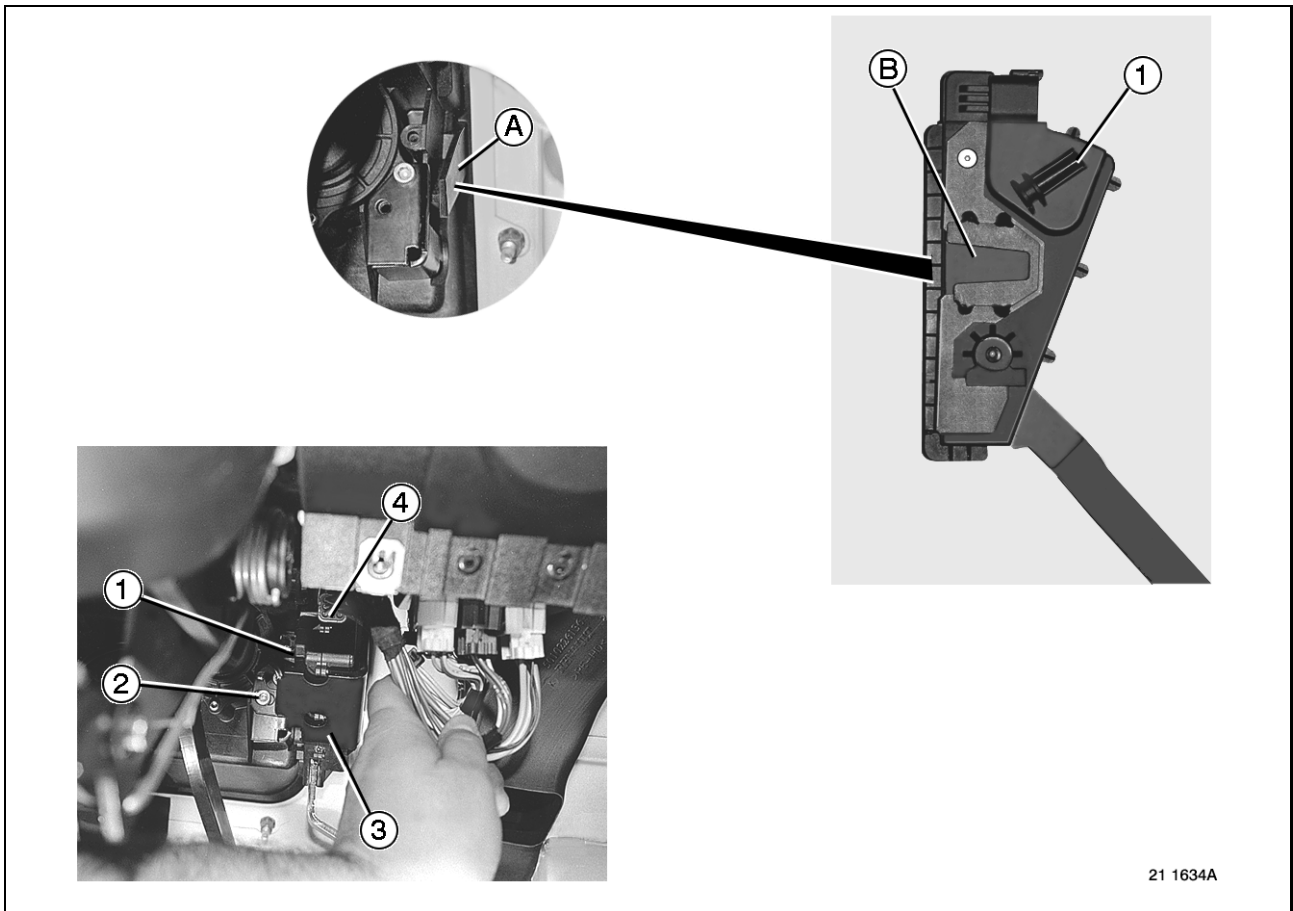

Removal

Remove the steering column trim.

Remove setscrew **(1)**.

Remove setscrew **(2)**.

Pull the accelerator pedal and holding plate **(3)** towards yourself to remove.

Unplug connector **(4)**.

Fitting

Offer up the holding plate **(3)** / accelerator pedal assembly.

Slide the bracket **(B)** in the rail **(A)**.

Tighten bolt **(1)** moderately.

Tighten bolt **(2)**.

Plug in connector **(4)**.

Fit the steering column trim.

Injectors

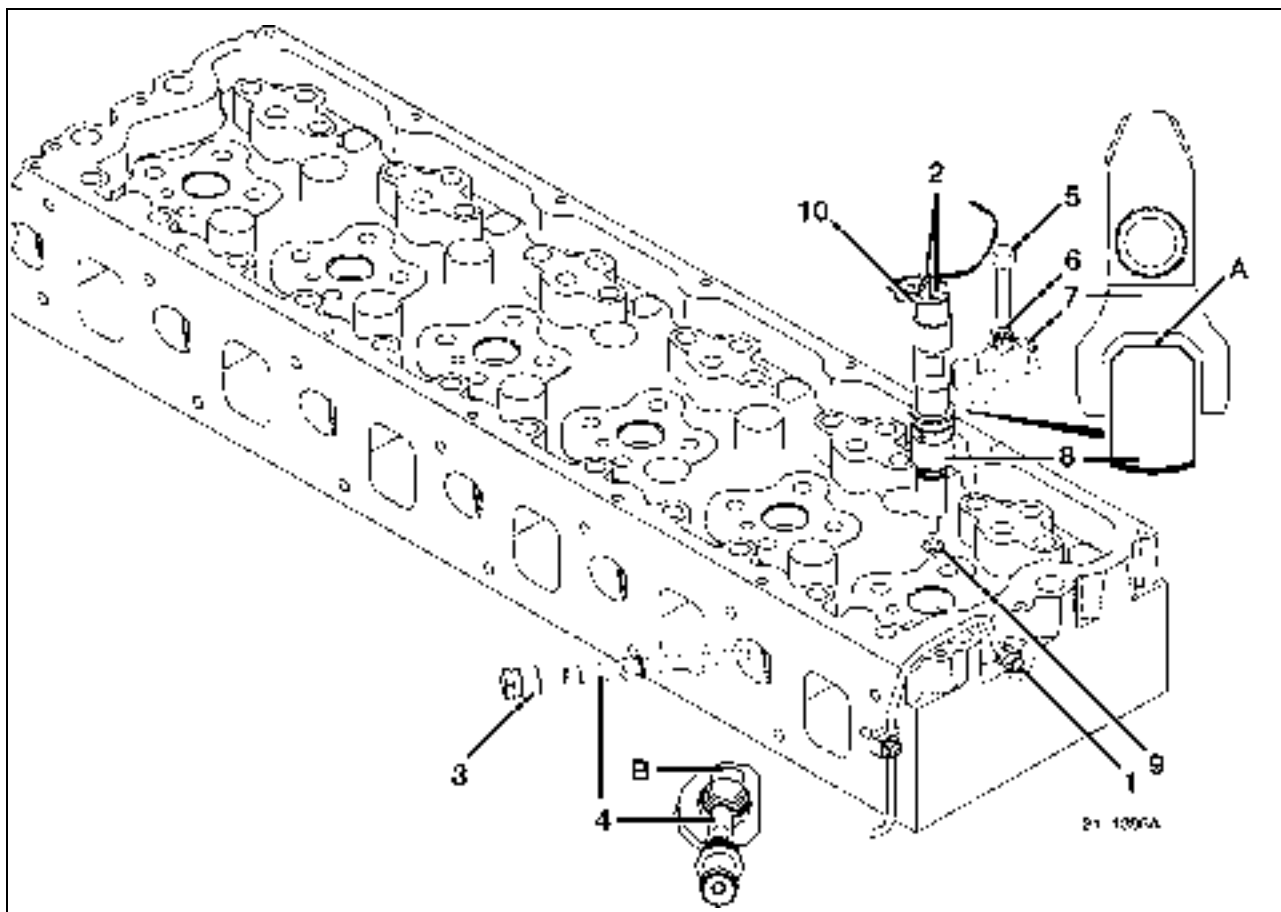

It is strictly forbidden to work on the fuel injectors while the engine is running (high voltage).



To remove and fit the other components quoted in the paragraph, refer to their respective chapters.

Removal

- Remove the corresponding injector pipe gallery.
- Remove the cylinder head cover.
- Depending on the equipment, remove the Jake brake.
- Remove union (1) to drain the fuel contained in the cylinder head.
- Unscrew nuts (2).
- Remove nut (3).
- Blank off the ports.
- Remove fuel delivery pipe (4) to the cylinder head
- Remove setscrew (5).
- Save spherical washer (6).
- Remove flange (7).
- Withdraw injector (8).
- Take off seal (9).
- Put each part in a new watertight plastic bag immediately after its removal.

Fitting

Replace all seals and gaskets without fail.

Replace all removed fuel delivery pipes **(4)** without fail.

Fit injector **(8)**.



It is essential to check for the presence of one single seal (9) to guarantee alignment of the fuel delivery pipe (4) with the injector (8), in order to ensure a perfect seal.

Match the orientation **(A)**.

Fit cylinder head fuel delivery pipe **(4)**.

Match the orientation **(B)**.

Wiggle the injector **(8)** and fuel delivery pipe **(4)** around to ensure their positioning.

Fit nut **(3)**.

Fit flange **(7)**.

Fit spherical washer **(6)**.

Fit setscrew **(5)**.

Screw up nut **(3)** and bolt **(5)** without tightening.

Preliminary tighten bolt **(5)** then nut **(3)** to a torque of **5 Nm**.

Final tighten bolt **(5)** then nut **(3)** to a torque of **60 Nm**.

For the rest of the fitting operations, proceed in the reverse sequence to removal.

Hold terminal lugs **(10)** of the wiring harness with pliers when tightening nuts **(2)** to torque.

Rail leak-off return pipe

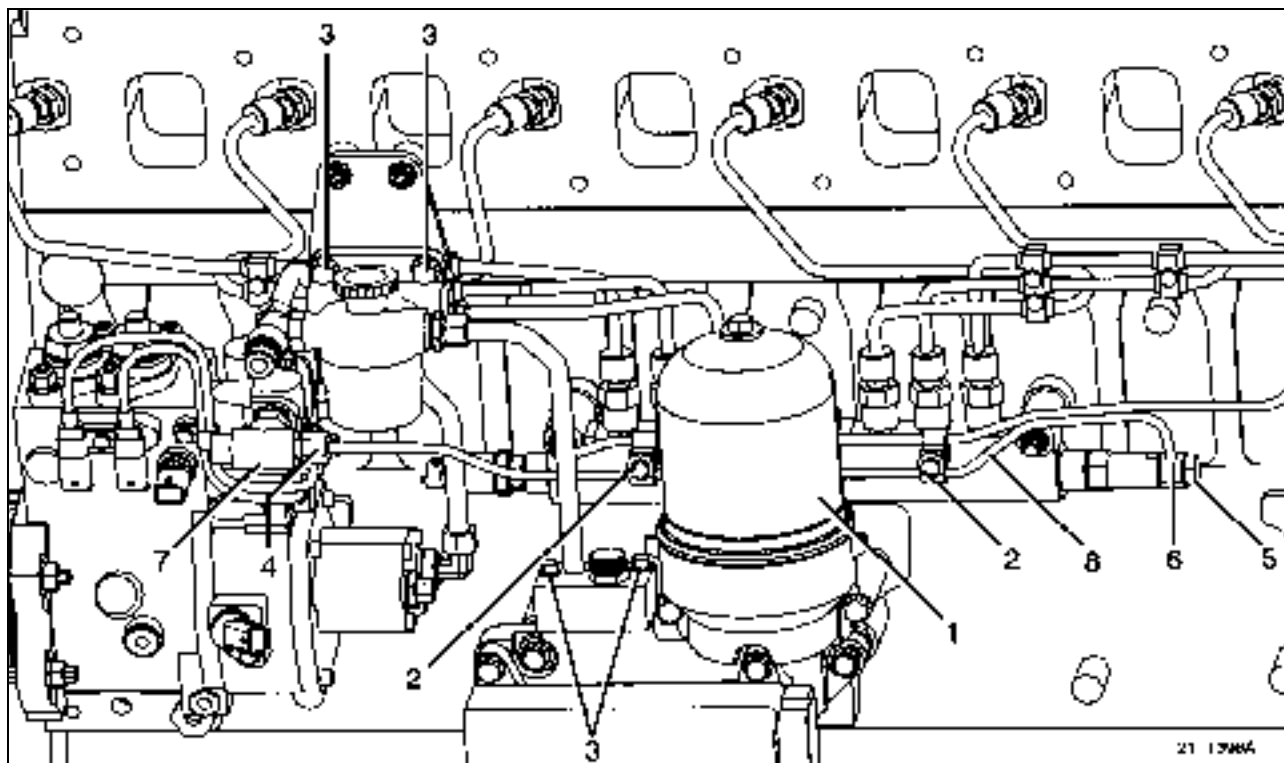

Removal

Remove centrifugal filter (1).

Remove the nuts (2).

Remove securing bolts (3).

Unscrew connectors (4 - 5).

Loosen union (5) while holding end (6) of leak-off return pipe with a wrench.

Loosen union (4) while holding union (7).

Blank off the ports.

Remove pipe (8).

Save the pipe fastening clamps.

Watch out not to bend the pipes.

Put each part in a new watertight plastic bag immediately after its removal.

Fitting

To fit, proceed in the reverse sequence to removal.

Replace all seals and gaskets without fail.

Tighten union (5) while holding end (6) of leak-off return pipe with a wrench.

Tighten union (4) while holding union (7).

Tighten to torque.

See page B-2-6

Bleed the fuel system.

High pressure pump

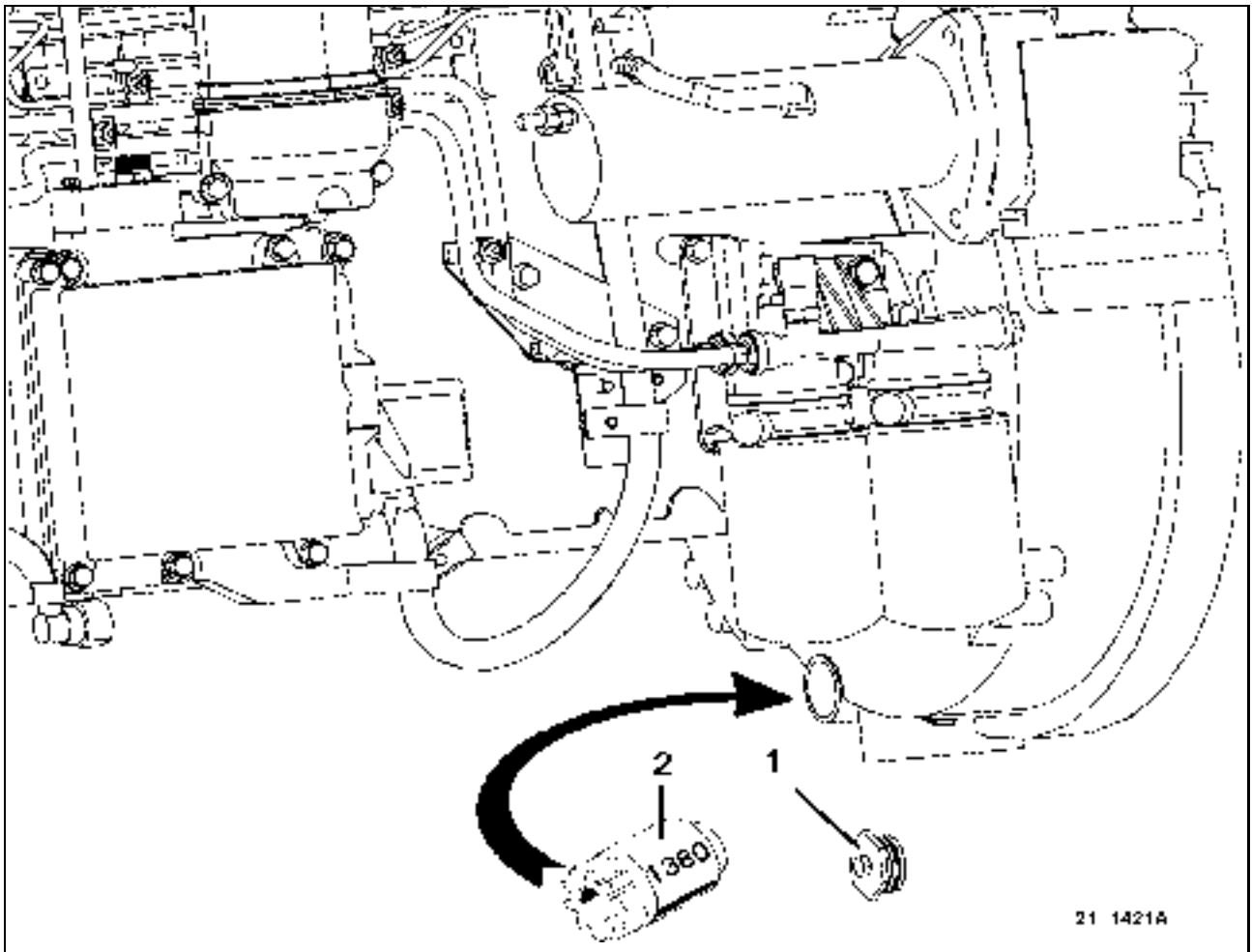

To remove and fit the other components quoted in the paragraph, refer to their respective chapters.

Removal

Remove blanking plug (1). Use tool 1380 (2) to crank the engine and bring the valves of N° 3 into balance. In this position, the pump shaft drive key is oriented upwards to prevent it from falling into the timing case.



To avoid off-setting the pinion, it is essential to use tool 2547 before removing the pump from the engine .

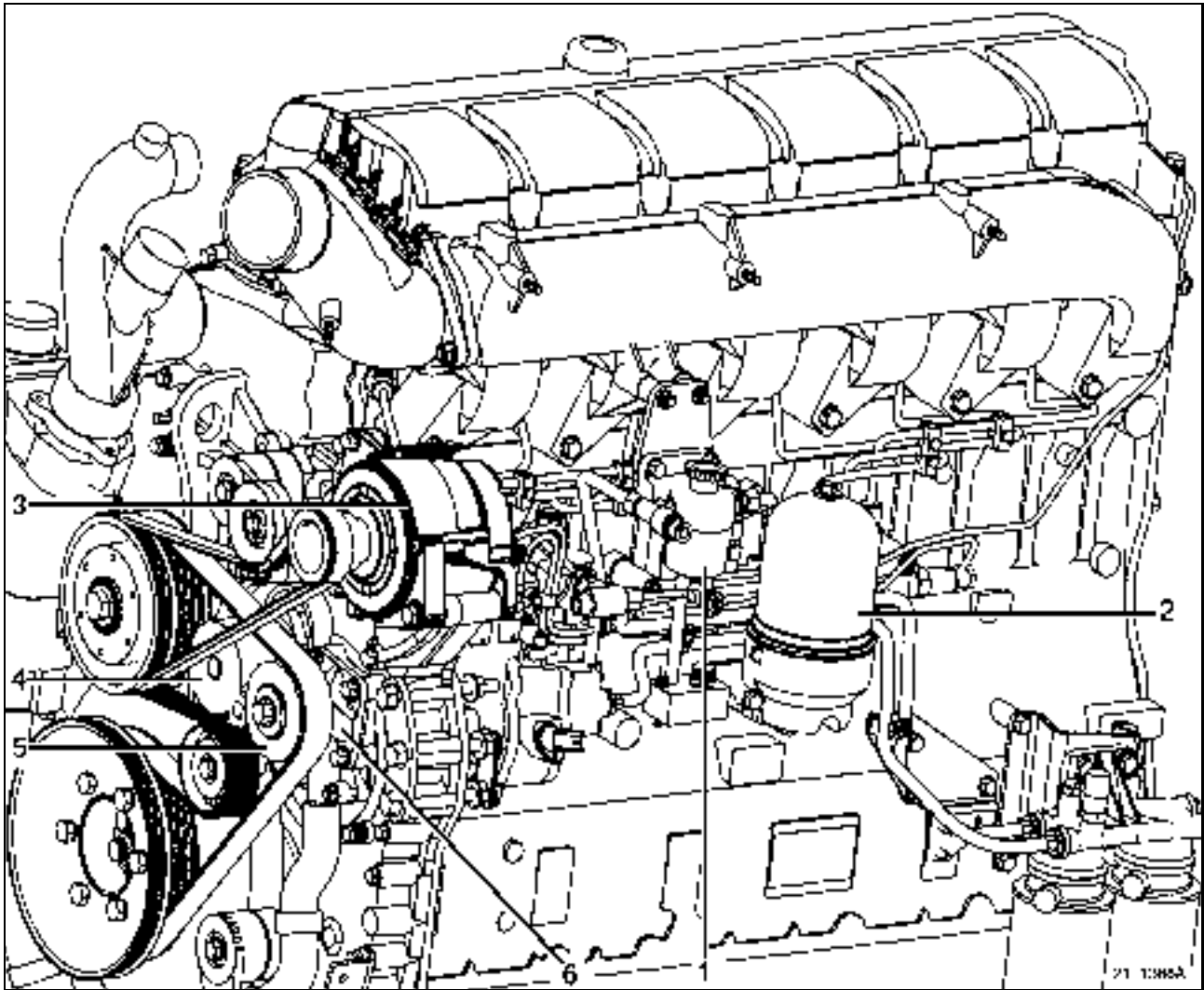

- Remove hand priming pump and prefilter (1).
- Remove centrifugal filter (2).
- Remove drive belts.
- Remove alternator (3).
- Remove tensioner (4).
- Remove jockey pulley (5).
- Remove breather (6).

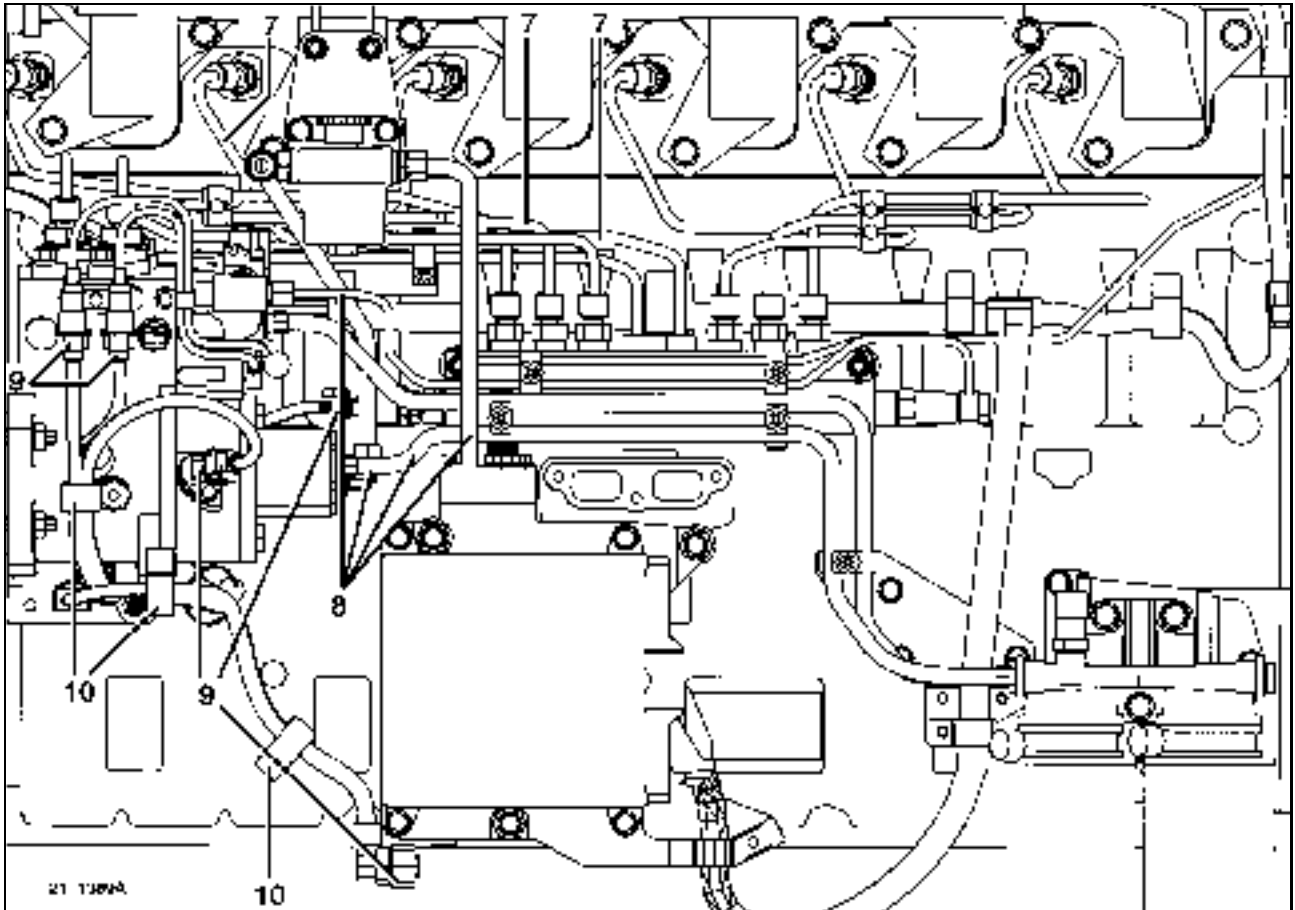

Remove high pressure pipe gallery (7).

Remove pipes (8).

Blank off the ports.

Unplug connectors (9).

Withdraw the clamps (10).

Extract the wiring harness from the space between the pump and the engine block.

Remove nut **(11)**, turn it round and screw it onto the pinion.
 Using an **(M14)** setbolt with a threaded length of **60 mm (12)**, extract the high pressure pump pinion.
 Immobilize the pinion using tool **2547**.
 Remove the nuts **(13)**.
 Put each part in a new watertight plastic bag immediately after its removal.

Fitting

Replace all seals and gaskets without fail.
 Apply oil to the O-rings.

Degrease the tapers.

Align the shaft key with the keyway in the pinion.
 Install high-pressure pump.
 Tighten nuts **(13)** to torque.

See page B-2-6

Tighten nut **(11)** while holding the high pressure pump shaft.
 Fill the high pressure pump with **0.2 litre** of engine oil through port **(14)**.

Put back the seal and tighten plug **(14)** to torque.

See page B-2-6

For the rest of the fitting operations, proceed in the reverse sequence to removal.
 Bleed the fuel system.

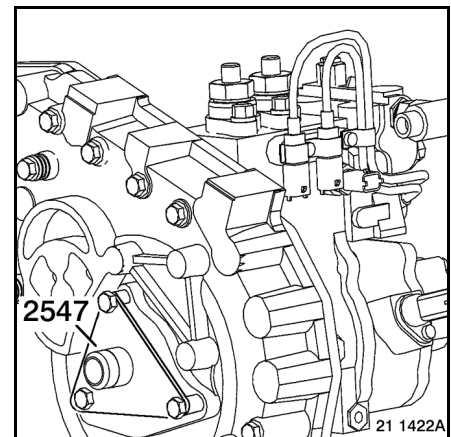
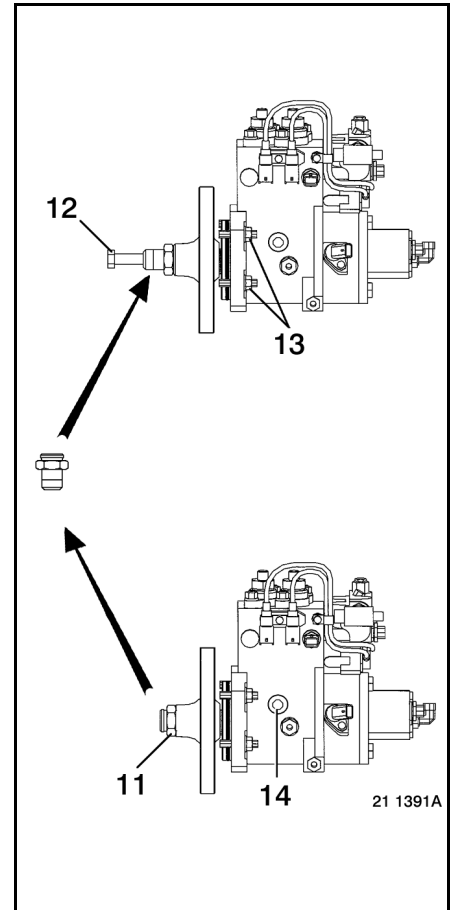

Booster pump ZP5

Removal

Remove securing nuts and bolts (1).

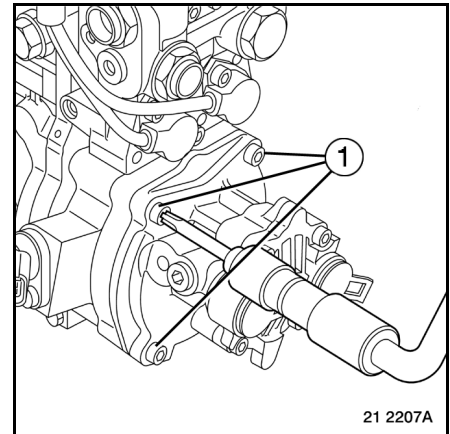

Dislodge booster pump (2) using a plastic mallet (3).

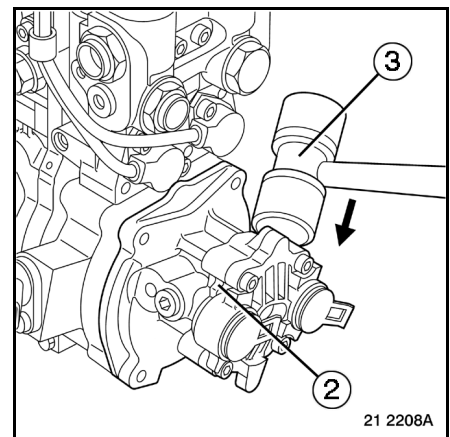

Remove booster pump (2).

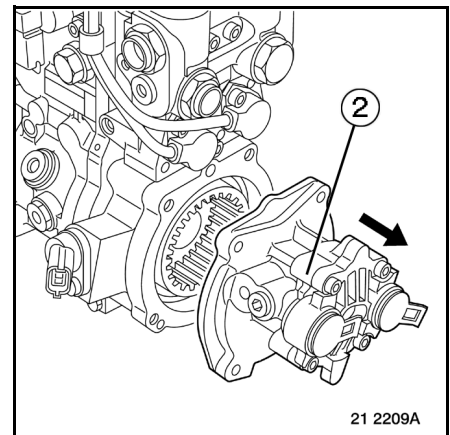

Fitting

To fit, proceed in the reverse sequence to removal.

Replace gasket **(4)** without fail.

Apply oil to the gasket **(4)** (engine oil).

Carefully align the booster pump with the high pressure pump.

Preliminary tighten the booster pump setscrews in diametrically opposed sequence.

Tighten to torque.

See page B-2-6

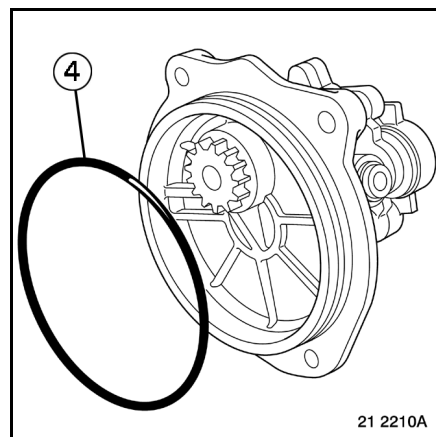
**High pressure pump speed sensor**

Booster pump ZP5 removed.

Removal

Remove setscrew **(1)**.

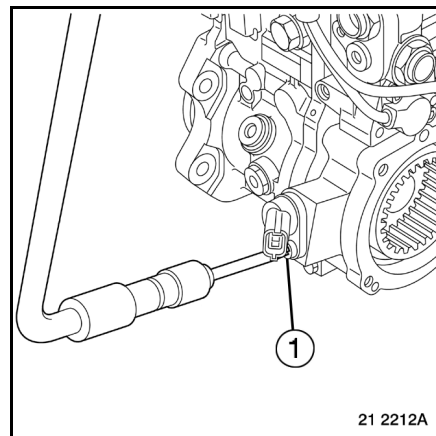

Remove sensor **(2)**.

Remove shim **(3)**.

Fitting

For fitting, proceed in the reverse sequence to removal.

Apply oil to the gasket (engine oil).

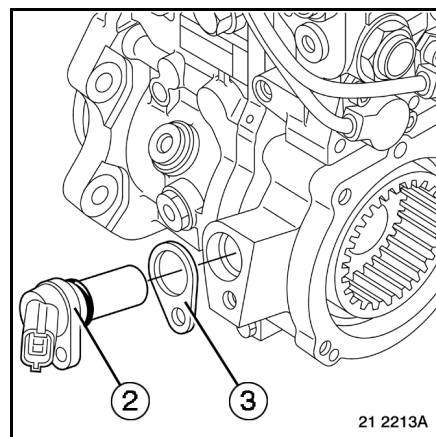

Check the size of air gap **A** = 0.3 ± 0.1 mm using feeler gauge **(4)**.
 If the size of the air gap does not conform, replace adjusting shim **(3)**.
 Tighten to torque.
See page B-2-6

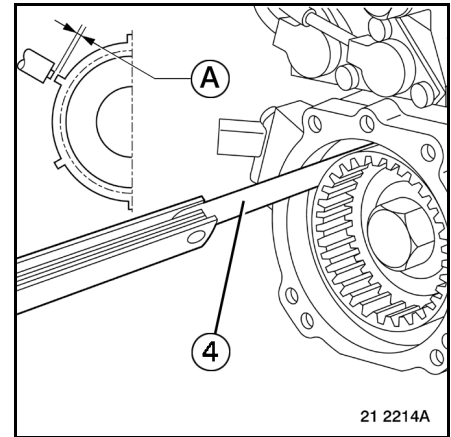

High pressure pump speed sensor

Booster pump ZP5 fitted.

Removal

See page J-2-18

Calculation of the shim thickness to obtain an air gap of 0.3 ± 0.1 mm.

Measure dimension **(a)** corresponding to the length of the sensor.

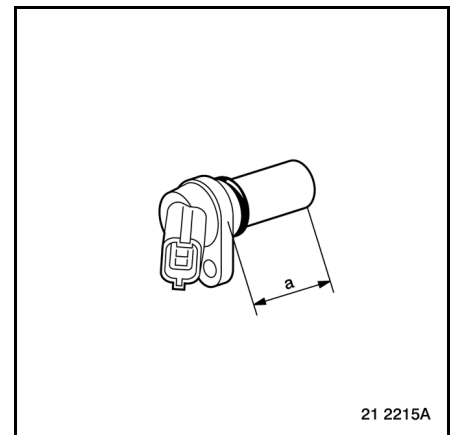

Measure dimension **(b)** corresponding to the distance between the sensor support face and the high pressure pump target.
 Thickness of sensor shim = $0.3 + (a) - (b)$.

Fitting

See page J-2-18

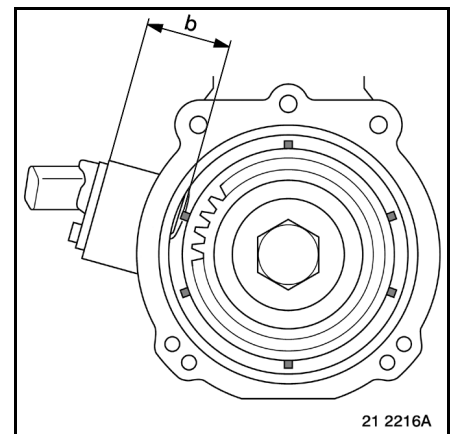

Scavenge valve

Removal

Remove scavenge valve (1).

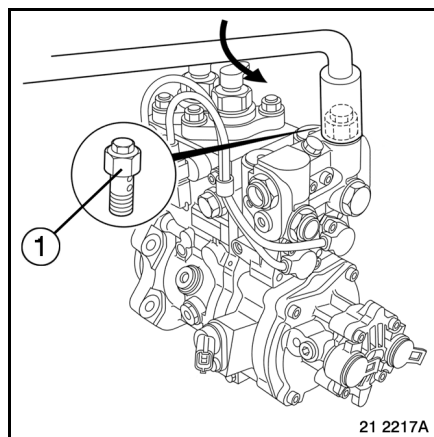

Disassembly

Tighten the scavenge valve in a vice.
Loosen plug (2).

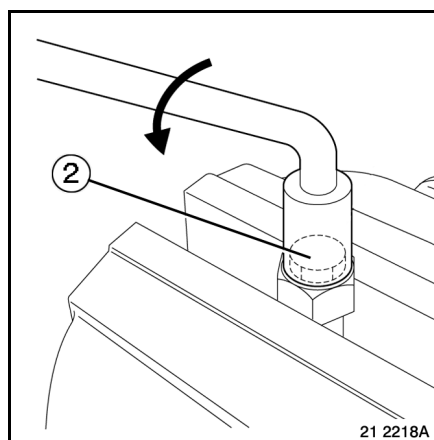

Remove plug (2).
Remove gasket (3).
Withdraw shims (4).
Remove spring (5).
Remove valve (6).
Carefully clean all the parts.
Visually check the condition of the contact surface of valve (6).

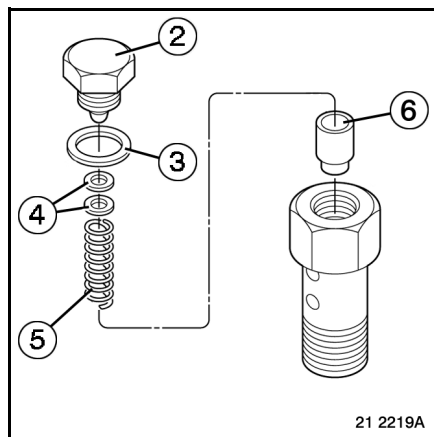

If any of these parts are lost, except for gasket (3), the high pressure pump will have to be replaced.

Assembly

Proceed in the reverse sequence to dismantling.
Replace gasket (3).

Tighten plug (2) to torque.
See page B-2-6

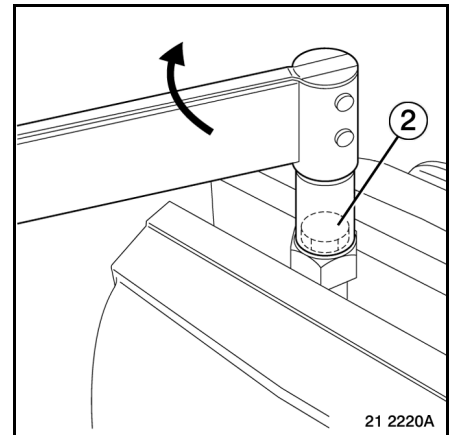
**Fitting**

To fit, proceed in the reverse sequence to removal.
Replace gasket (2).

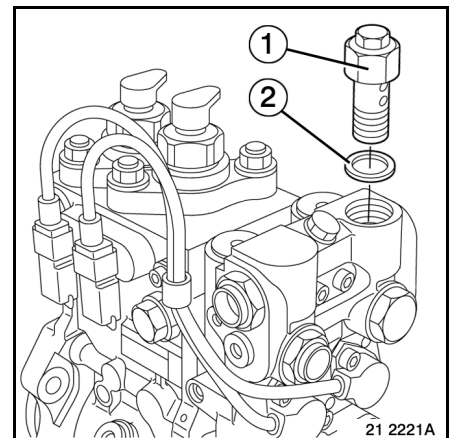

Tighten to torque.
See page B-2-6

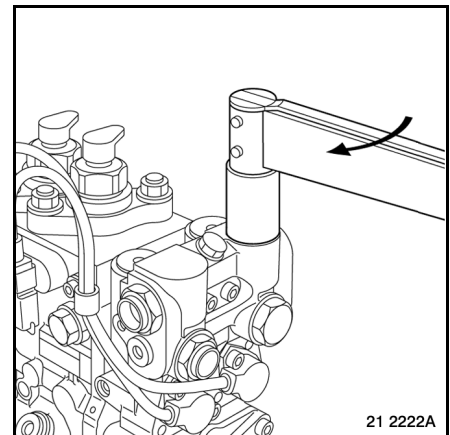

Checking the high pressure pump timing

Remove the rocker cover.

High pressure pump with number **(A)** < 182.

Remove the engine speed and HP pump speed sensors.

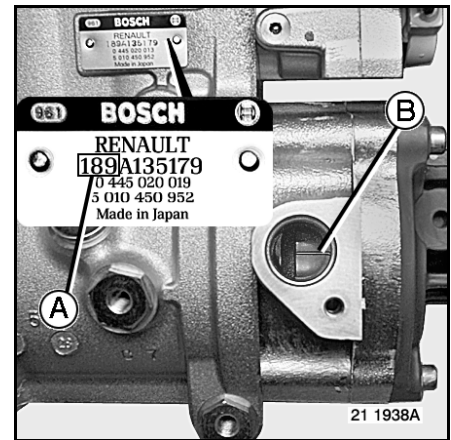

Mark (B) cannot be used for timing the high pressure pump.

Turn the engine in the direction of normal running, as far as compression **TDC** of N° 1 cylinder (valves of cylinder in balance with valves of N° 6 cylinder).

Turn the engine in the direction of normal running as far as the 2nd appearance of the hole-free zone on the flywheel through the speed sensor well.

Turn the engine in the direction of normal running, and bring the 17rd hole after this zone opposite the speed sensor well.

Check that the 1st tooth of the double-tooth of the HP pump target is visibly in the centre through the pump speed sensor well.

High pressure pump with number **(A)** ≥ 182.

Remove the high pressure pump speed sensor.

Turn the engine in the direction of normal running, as far as compression **TDC** of N° 1 cylinder (valves of cylinder in balance with valves of N° 6 cylinder).

Mark **(B)** should appear centred in the high pressure pump speed sensor well.



The TDC of N° 1 cylinder is situated at the 31th hole after the hole-free zone on the flywheel through the engine speed sensor well (on certain flywheels, this hole is marked on both sides).

Fuel pipes (low pressure)

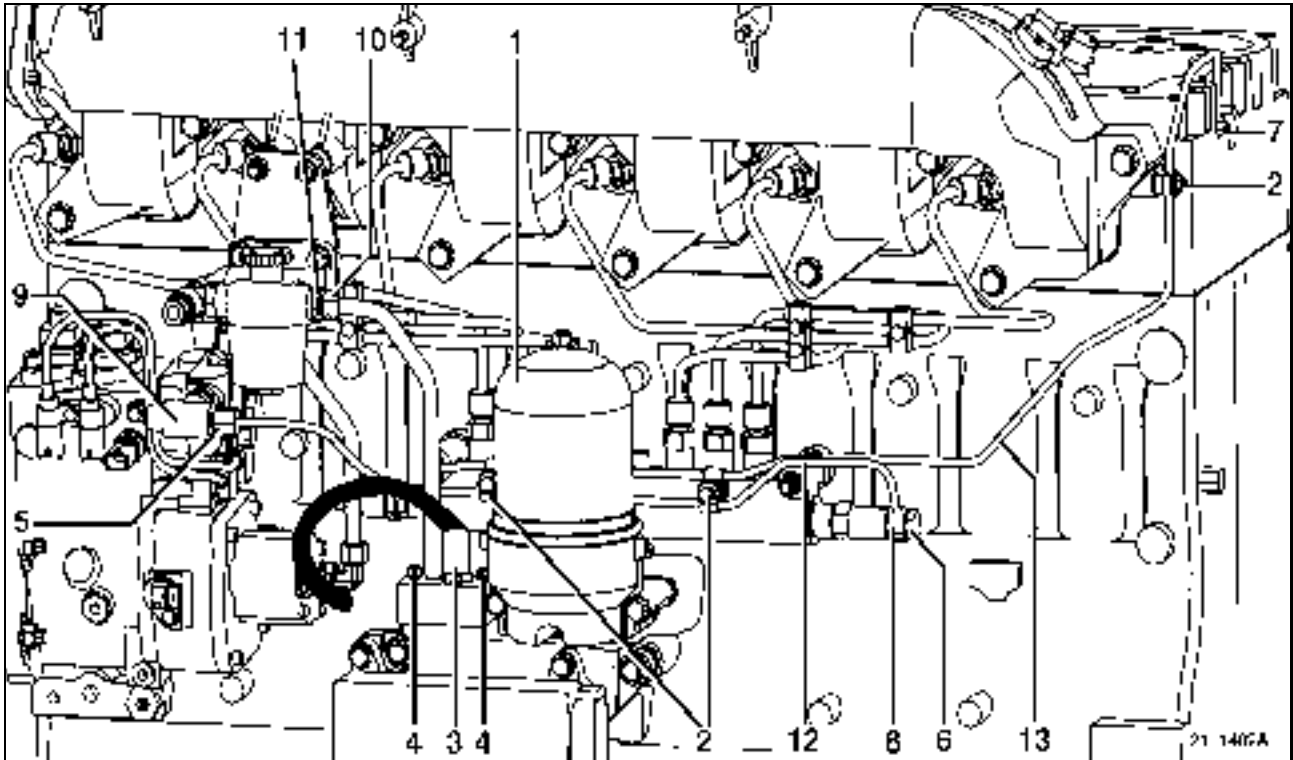

Removal

- Remove centrifugal filter (1).
- Remove the nuts (2).
- Disconnect union (3).
- Remove securing bolts (4).
- Unscrew connectors (5 - 6 - 7 - 10).
- Loosen union (6) while holding end (8) of leak-off return pipe with a wrench.
- Loosen union (5) while holding union (9).
- Loosen union (10) while holding union (11).
- Remove tubes (12 - 13).
- Blank off the ports.
- Save the pipe fastening clamps.
- Watch out not to bend the pipes.
- Put each part in a new watertight plastic bag immediately after its removal.

Fitting

- Replace all seals and gaskets without fail.
- To fit, proceed in the reverse sequence to removal.
- Tighten union (10) while holding union (11).
- Tighten union (5) while holding union (9).
- Tighten union (6) while holding end (8) of leak-off return pipe with a wrench.
- Tighten to torque.

See page B-2-6

Bleed the fuel system.

Common rail

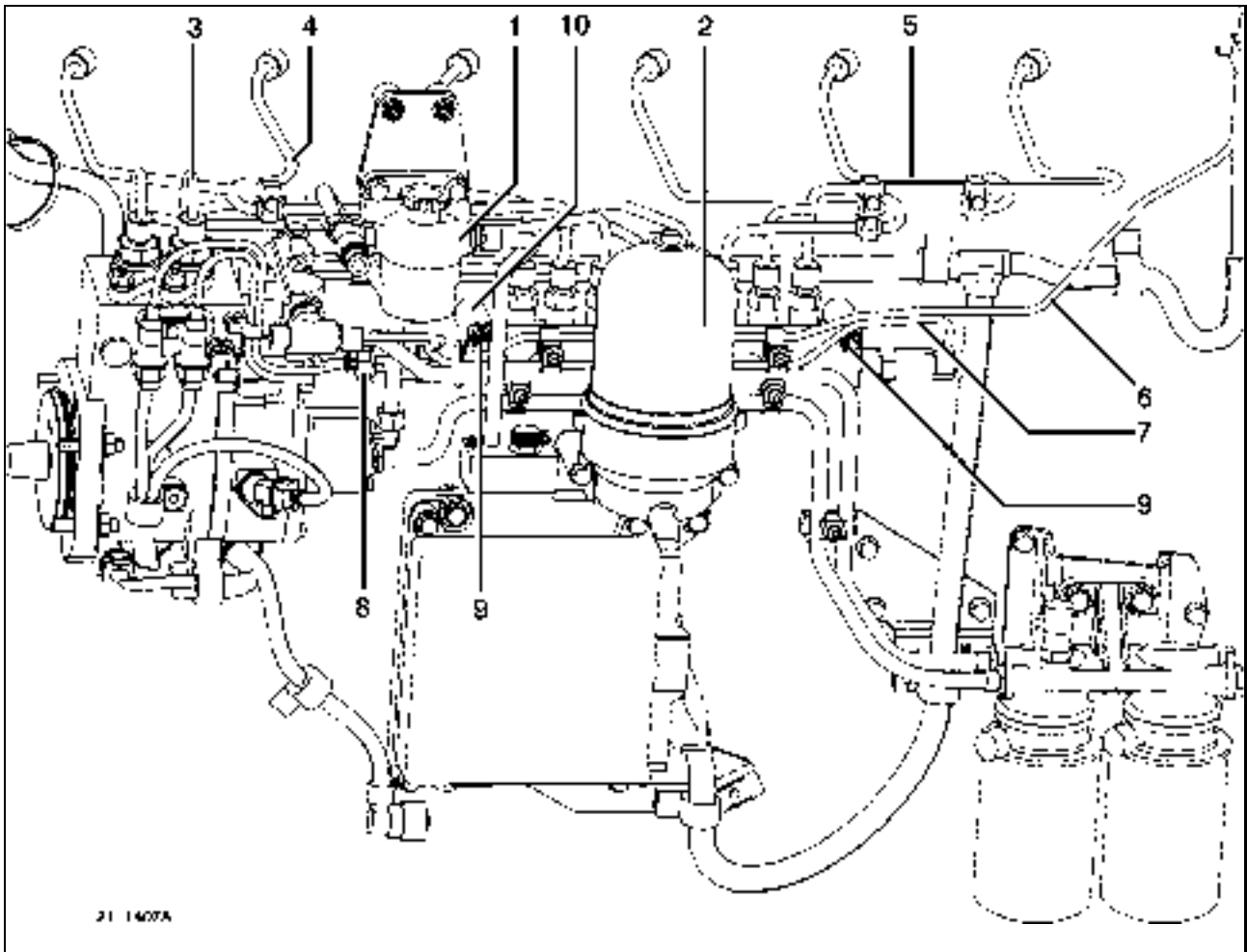

To remove and fit the other components quoted in the paragraph, refer to their respective chapters.

Removal

Remove hand priming pump and prefilter (1).

Remove centrifugal filter (2).

Remove high pressure pipe gallery (3 - 4 - 5).

Remove pipes (6 - 7).

If the starter is in position on the engine, remove the rail pressure limiter.

See page J-2-25

Blank off the ports.

Unplug the connector (8).

Remove nuts (9).

Remove common rail (10).

Put each part in a new watertight plastic bag immediately after its removal.

Fitting

For fitting, proceed in the reverse sequence to removal.

Tighten to torque.

See page B-2-6

Bleed the fuel system.

Rail pressure limiter

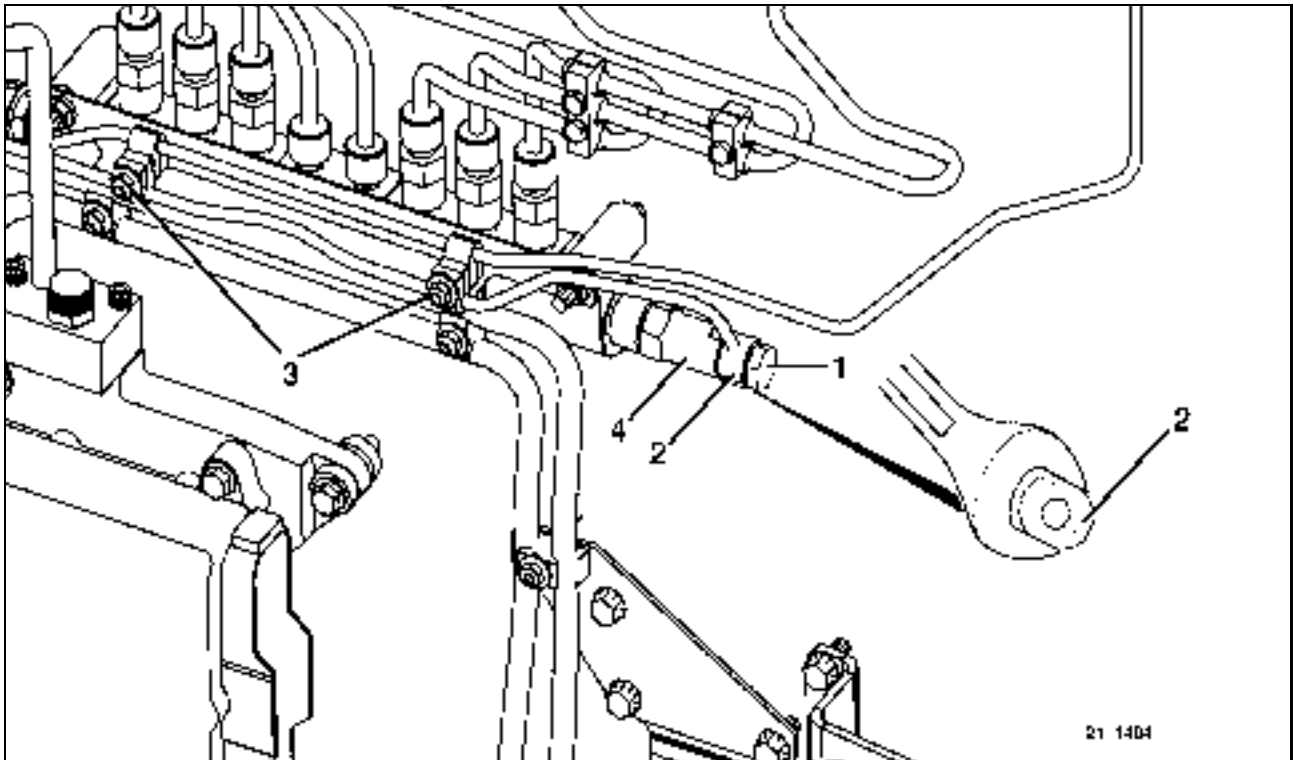

To remove and fit the other components quoted in the paragraph, refer to their respective chapters.

Pressure limiter (4) is to be replaced without fail if the engine is running at abnormally high pressure ("fuel flow regulation solenoid valve" or "fuel injection pressure outside operating band" fault).

Removal

- Remove union (1) while holding end (2) with a wrench.
- Loosen the nuts (3).
- Move pipe (2).
- Remove pressure limiter (4).
- Blank off the ports.
- Put each part in a new watertight plastic bag immediately after its removal.

Fitting

- For fitting, proceed in the reverse sequence to removal.
- Tighten union (1) while holding end (2) of leak-off return pipe with a wrench.
- Tighten to torque.

See page B-2-6

Flow limiter

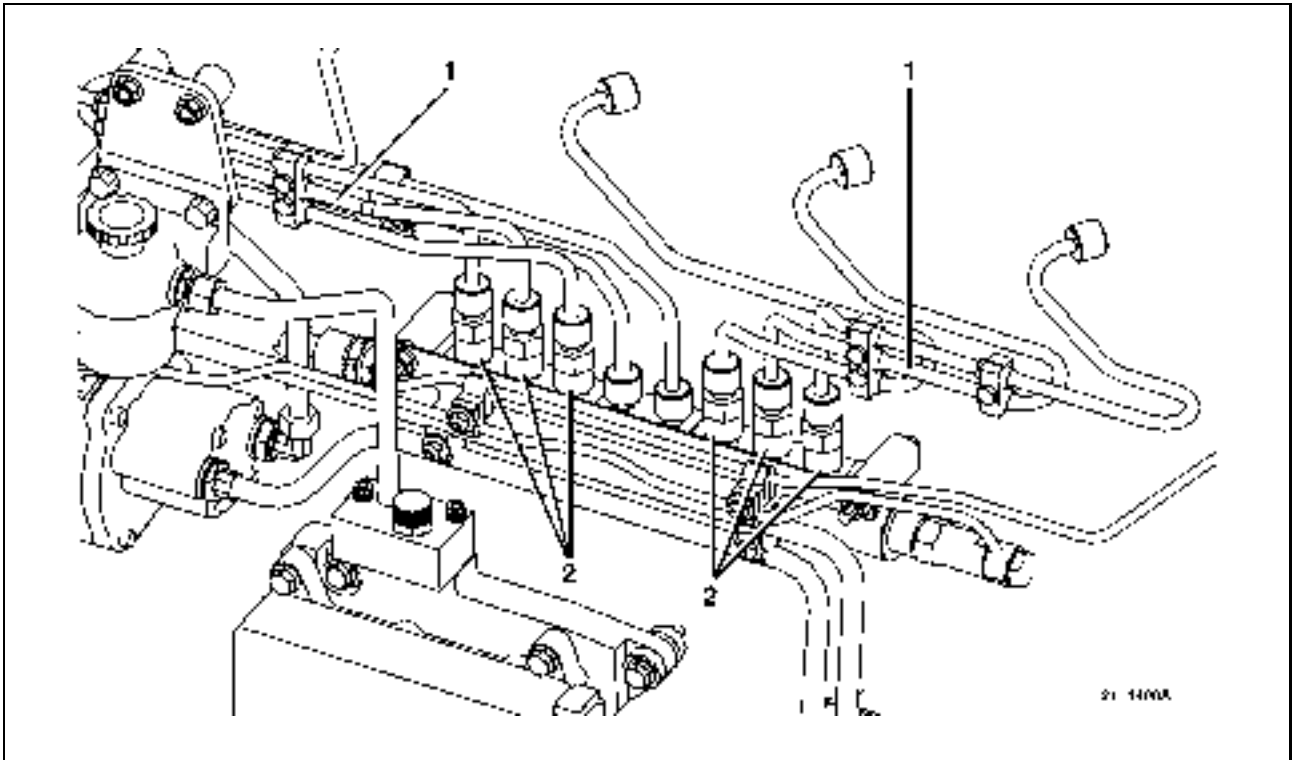

To remove and fit the other components quoted in the paragraph, refer to their respective chapters.

Removal

Remove pipes gallery (1).

Remove flow limiter (2).

Blank off the ports.

Put each part in a new watertight plastic bag immediately after its removal.

Fitting

For fitting, proceed in the reverse sequence to removal.

Tighten to torque.

See page B-2-6

Fuel high pressure sensor

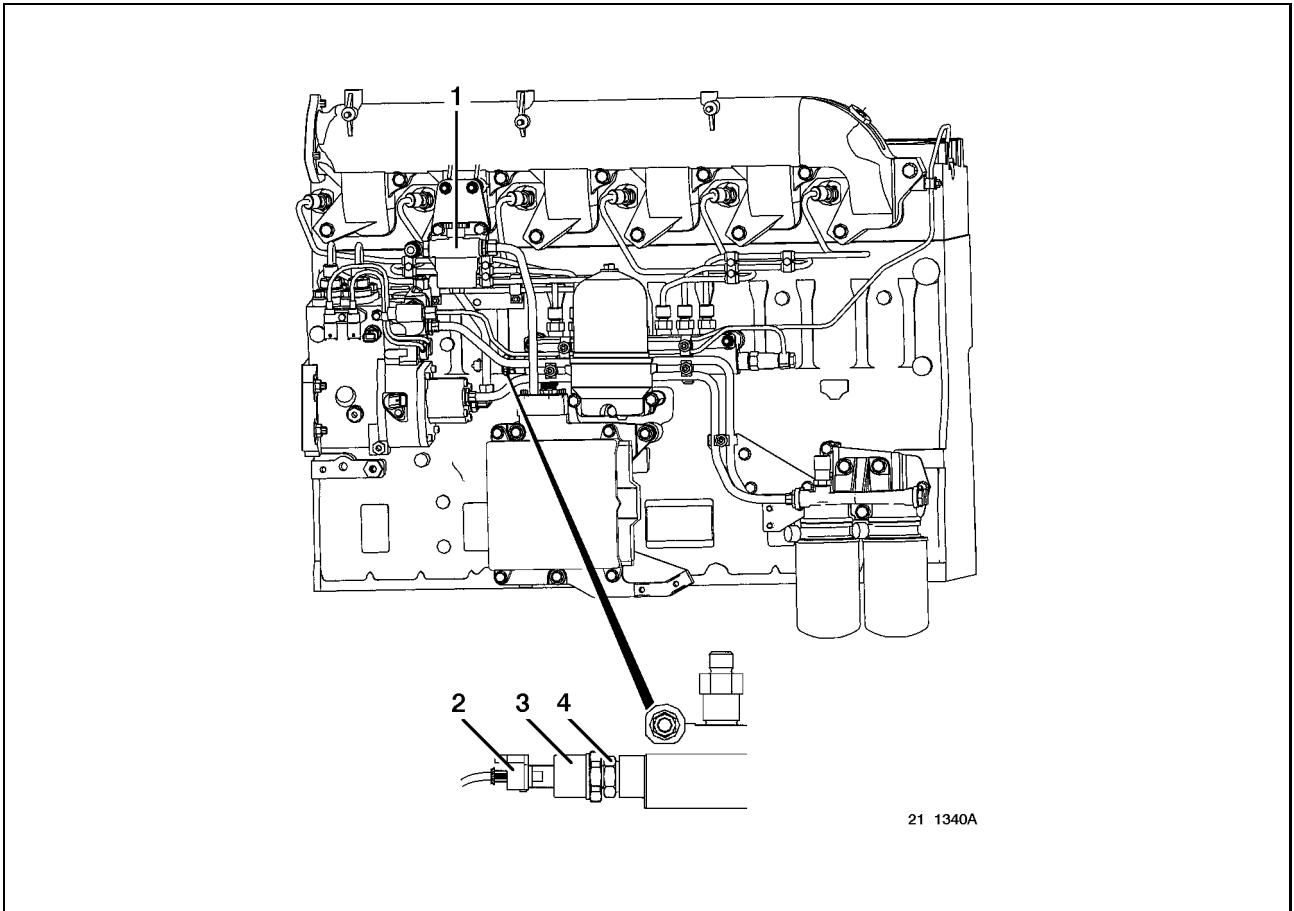

Removal

Remove hand priming pump and prefilter (1).

Unplug the connector (2).

Unscrew sensor (3) while holding sleeve (4).

Blank off the ports.

Put each part in a new watertight plastic bag immediately after its removal.

Fitting

For fitting, proceed in the reverse sequence to removal.

Tighten to torque.

See page B-2-6

Bleed the fuel system.

Engine speed, boost air pressure and temperature sensors

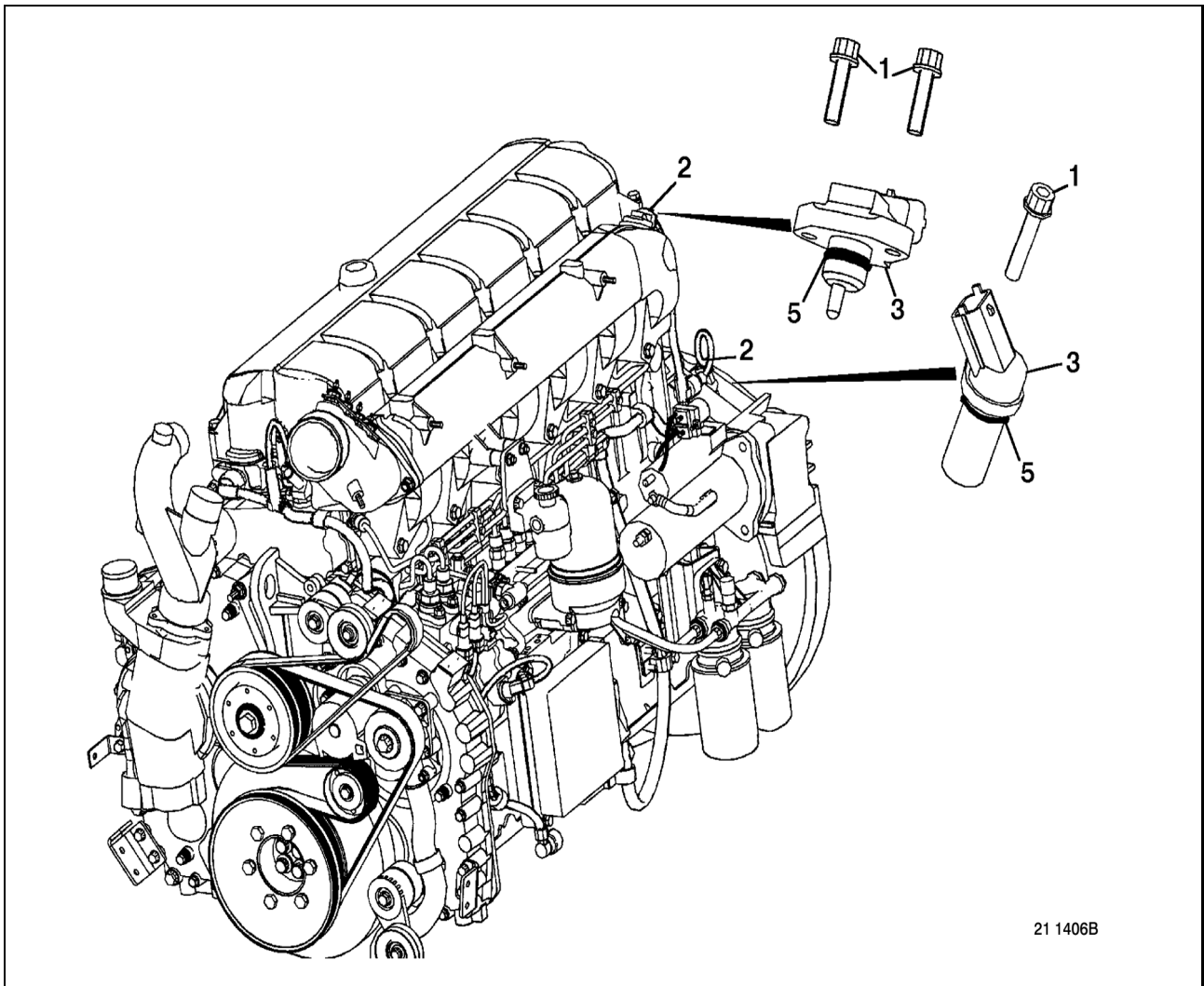

To remove and fit the other components quoted in the paragraph, refer to their respective chapters.

Removal

- Remove setscrew(s) **(1)**.
- Unplug connector **(2)**.
- Remove sensors **(3)**.

Fitting

- Replace seals **(5)**.
- Grease seals **(5)**.
- To fit, proceed in the reverse sequence to removal.
- Tighten to torque.

See page B-2-6

Engine master ECU

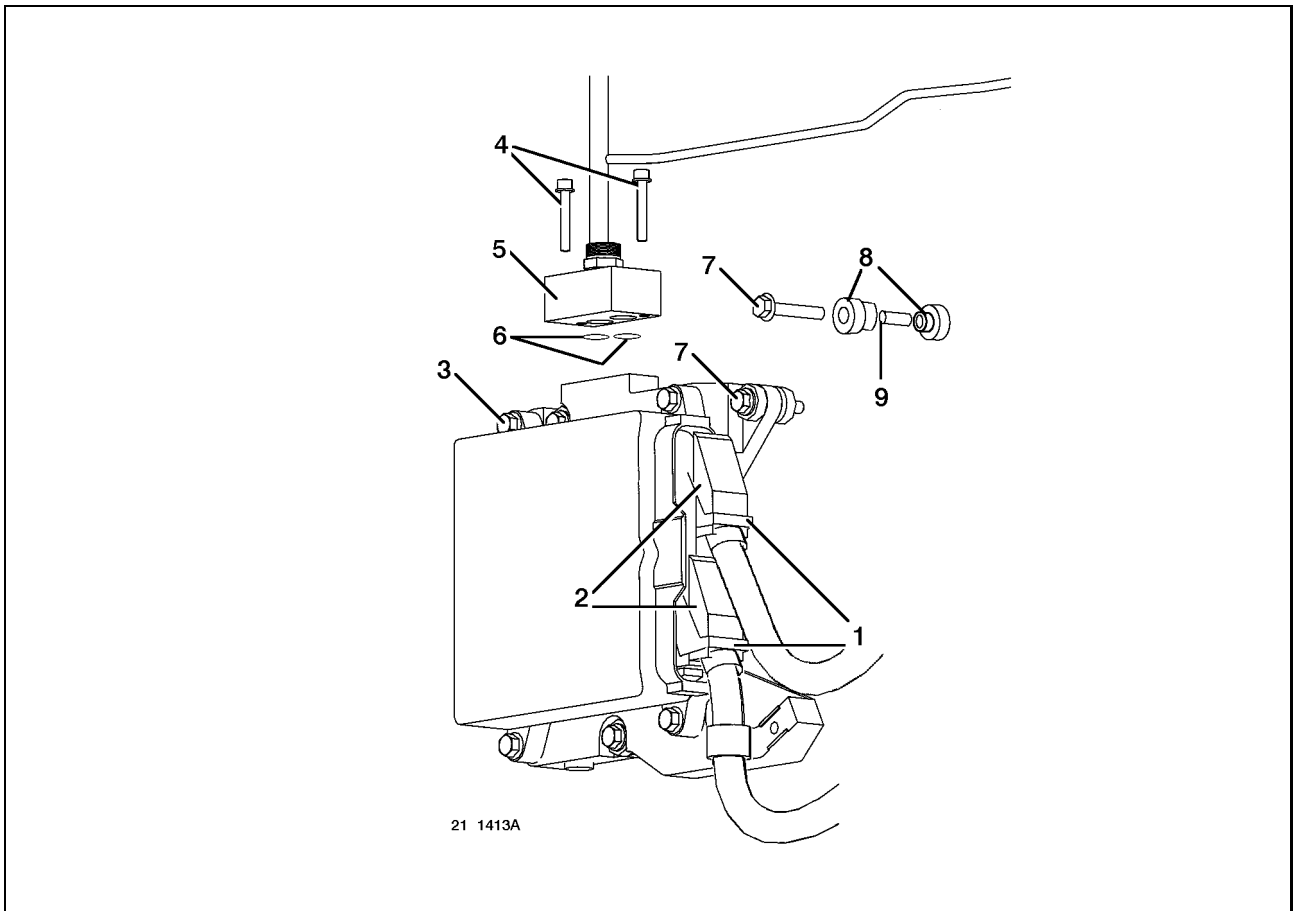

Engine master electronic control unit (EECU)

Removal

Pull out the catches **(1)** and unplug connectors **(2)**.
Remove securing bolts **(3)**.

Fitting

To fit, proceed in the reverse sequence to removal.
Two lugs on the cooler serve to position the ECU.
Tighten to torque.

See page B-2-2

ECU cooler

Removal

Remove securing bolts **(4)**.
Move pipe **(5)**.
Blank off the ports.
Remove the sensor **(6)**.
Remove securing bolts **(7)**.
Put each part in a new watertight plastic bag immediately after its removal.

Fitting

To fit, proceed in the reverse sequence to removal.
It is vital to change the joints **(6)**.
Check the condition of rubber bushes **(8 - 9)**.

Tighten to torque.

See page B-2-2

Bleed the fuel system.

Wiring harness

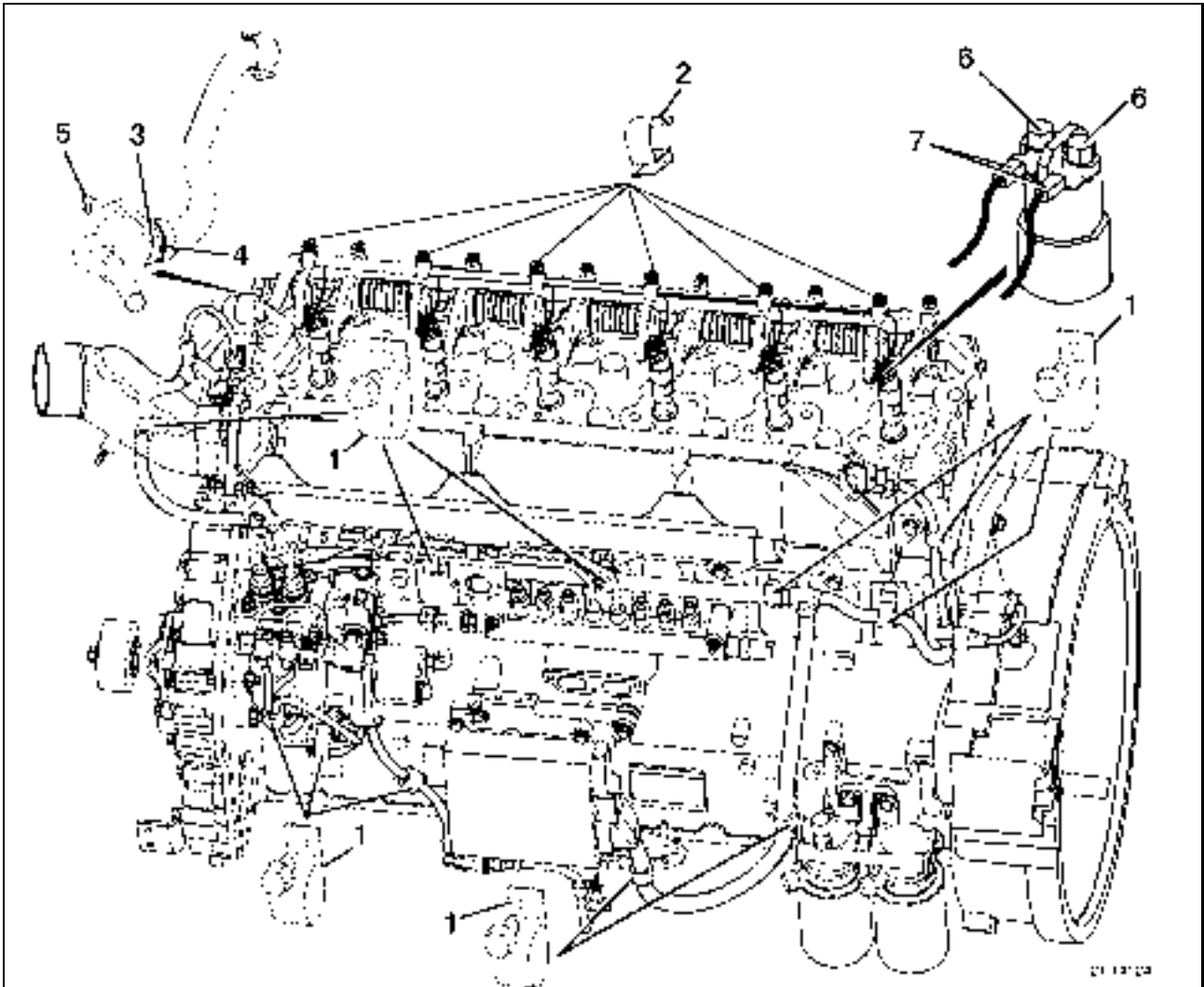

Removal

Remove the high pressure pipe lines.

Unplug connectors.

Remove clamps (1).

Remove the cylinder head cover.

Unscrew nuts (6).

Hold connecting lugs (7) when loosening nuts (6).

Remove setscrew (5) and disengage grommet (3).

Disengage the wiring harness from fastening clips (2).

Extract the wiring harness from the cylinder head.

Put each part in a new watertight plastic bag immediately after its removal.

Fitting

Replace gasket (4).

Check the condition of clips (2).

It is essential to use all the clamps (1) and all the clips (2) to fasten the wiring harness.

Tighten the nuts (6).

Hold connecting lugs (7) when tightening nuts (6).

Tighten to torque.

See page B-2-7

DIAGNOSTICS AID (SETTING B43)

Diagnostic (dCi 11 B43)

Instrument panel indicator lights

Indicator lights (1 - 2 - 3 - 4) inform the driver on the state of the system and on the kind of faults possibly detected or memorized.

Indications informing that the system is fully operational

As soon as the ignition is switched on, lights (2 - 3 - 4) come on for 3 seconds then go out .

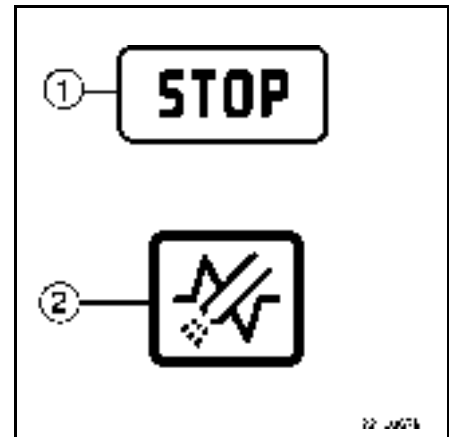

In the event of fault

Presence of minor fault: warning lights (3 - 4) come on.

The system functions by virtue of default values that replace values that can no longer be measured. Certain functions may be inhibited or operate in fall-back mode.

Presence of major fault: warning lights (1 - 2 - 3 - 4) come on.

The system functions in "emergency mode". The features provided are significantly affected and may lead to starting the engine being forbidden.

In all cases, the fuel-injection system needs urgent maintenance.

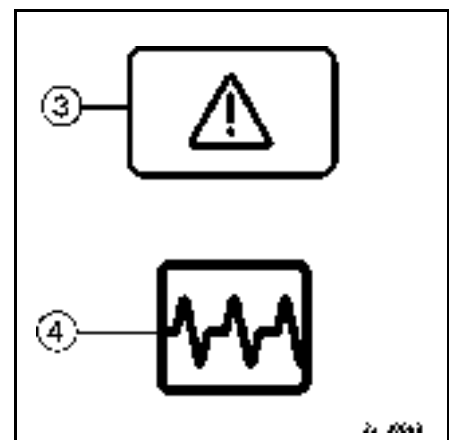

In the case of detection of fault, engine performance is impaired by means of limitation of pressure in the common rail. Depending on the kind of fault, three pressure limitation levels are possible:

- 1300 bars = 5% drop in engine power,
- 1000 bars = 20% drop in engine power,
- 850 bars = 50% drop in engine power.

Faults can be visualized by using the RENAULT TRUCKS diagnostics tool DIAGNOSTICA plugged into the vehicle diagnostics socket (5) .

Faults can also be visualized on the instrument panel information display with the display of code numbers in the "present faults" or "memorized faults" sub-menus

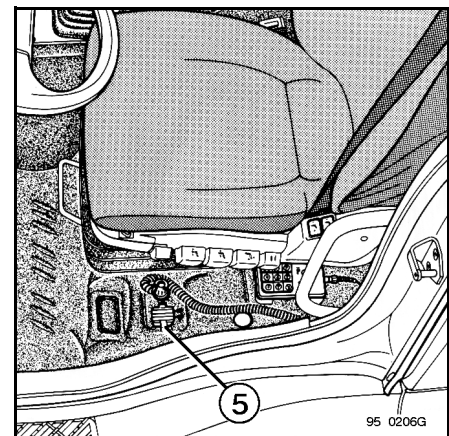

Use of the RENAULT TRUCKS diagnostic tool DIAGNOSTICA

The use of this tool provides great ease of diagnostics and its employment is strongly recommended. It is absolutely essential for erasing faults. Plug the diagnostics tool into the socket.

Available functions:

1/ Present faults

- component
- fault
- remedies

2/ Memorized faults

- component
- fault
- remedies
- erasure

3/ Diagnostic

- Diagnostics according to function
 - Exhaust brake
 - Cylinder balancing
 - Declutching fan
 - Injection pressure
 - PTO
 - Warm-up
 - Exhaust brake strangler
- Visualization of inputs (digital displays and/or graphics of next values)
 - Engine operating time
 - Accelerator pedal position (%)
 - Battery voltage
 - Coolant level
 - Engine oil level
 - Coolant temperature
 - Boost air temperature
 - Fuel temperature (depending on equipment)
 - Atmospheric pressure
 - Engine oil pressure
 - Boost air pressure
 - Injection pressure
 - Engine speed
 - Vehicle road speed
 - Declutching fan speed
 - Injected fuel quantity
 - Injection timing
 - Exhaust brake presence
 - Jake brake presence
 - Exhaust brake pilot-control set-point
 - Air conditioning system in operation
 - Fast idling speed set-point (PTO)



The values for adjusting the accelerator pedal position are shown in the "VECU" menu.

List of fault code numbers



The repercussion of the fault code numbers listed hereafter is only significant in the event of one single fault being present. If there are several present faults, the impairment of the system features provided may be greater and lead to operating impossibility.

Only code numbers specific to fuel-injection are covered in this document.

Faults relative to other functions may impair the features provided by the fuel-injection system (refer to the workshop manual sections corresponding to the systems incriminated).

To perform more comprehensive diagnostics on vehicle wiring harness runs, refer to the "PREMIUM Electrics" or "KERAX Electrics" workshop manual section for the vehicle.

Recap table of fault code numbers

Fault code	Nature of the incident	See page
1 - 1	Engine oil pressure sensor	K-8
1 - 3	Boost air pressure sensor	K-8
1 - 5	Engine cooling circuit temperature sensor	K-8
1 - 6	Boost air temperature sensor	K-9
1 - 7	Engine oil temperature sensor	K-9
1 - 9	Engine oil level sensor	K-9
2 - 1	Declutching fan speed sensor	K-10
2 - 2	Flywheel speed sensor	K-10
2 - 3	High pressure pump rotating speed sensor	K-10
2 - 4	Fuel high pressure sensor	K-10
2 - 5	Sensors "+" 5 Volts current supply fault	K-11
2 - 8	Engine stop control (cab tilted)	K-11
3 - 2	Exhaust brake electrovalve	K-11
3 - 3	Jake brake solenoid valve N° 1	K-12
3 - 4	Jake brake solenoid valve N° 2	K-12
3 - 7	Declutching fan speed regulation solenoid valve	K-12
4 - 1	N° 1 cylinder fuel injector	K-13
4 - 2	N° 2 cylinder fuel injector	K-13
4 - 3	N° 3 cylinder fuel injector	K-13
4 - 4	N° 4 cylinder fuel injector	K-13
4 - 5	N° 5 cylinder fuel injector	K-13
4 - 6	N° 6 cylinder fuel injector	K-13
5 - 1	Fuel flow regulation solenoid valve N° 1	K-14
5 - 2	Fuel flow regulation solenoid valve N° 2	K-14
5 - 3	Injection pressure outside operating band	K-14

Fault code	Nature of the incident	See page
5 - 5	Battery charge voltage incorrect	K-15
5 - 6	Communication line between engine and vehicle ECUs (CAN bus)	K-15
5 - 8	Engine ECU fault	K-15
5 - 9	Engine ECU power supply relay (R40)	K-16
6 - 1	Accelerator pedal position sensor	K-16
6 - 5	Cruise-control switch	K-17
9 - 6*	Absence of communication between vehicle and retarder ECUs	

The cruise-control switch also serves to emit code **(9 - 6)** which does not concern the fuel-injection system. Use the RENAULT TRUCKS diagnostics tool DIAGNOSTICA.

Assignment of pins to ECU wiring harness connector

(Connector face view)

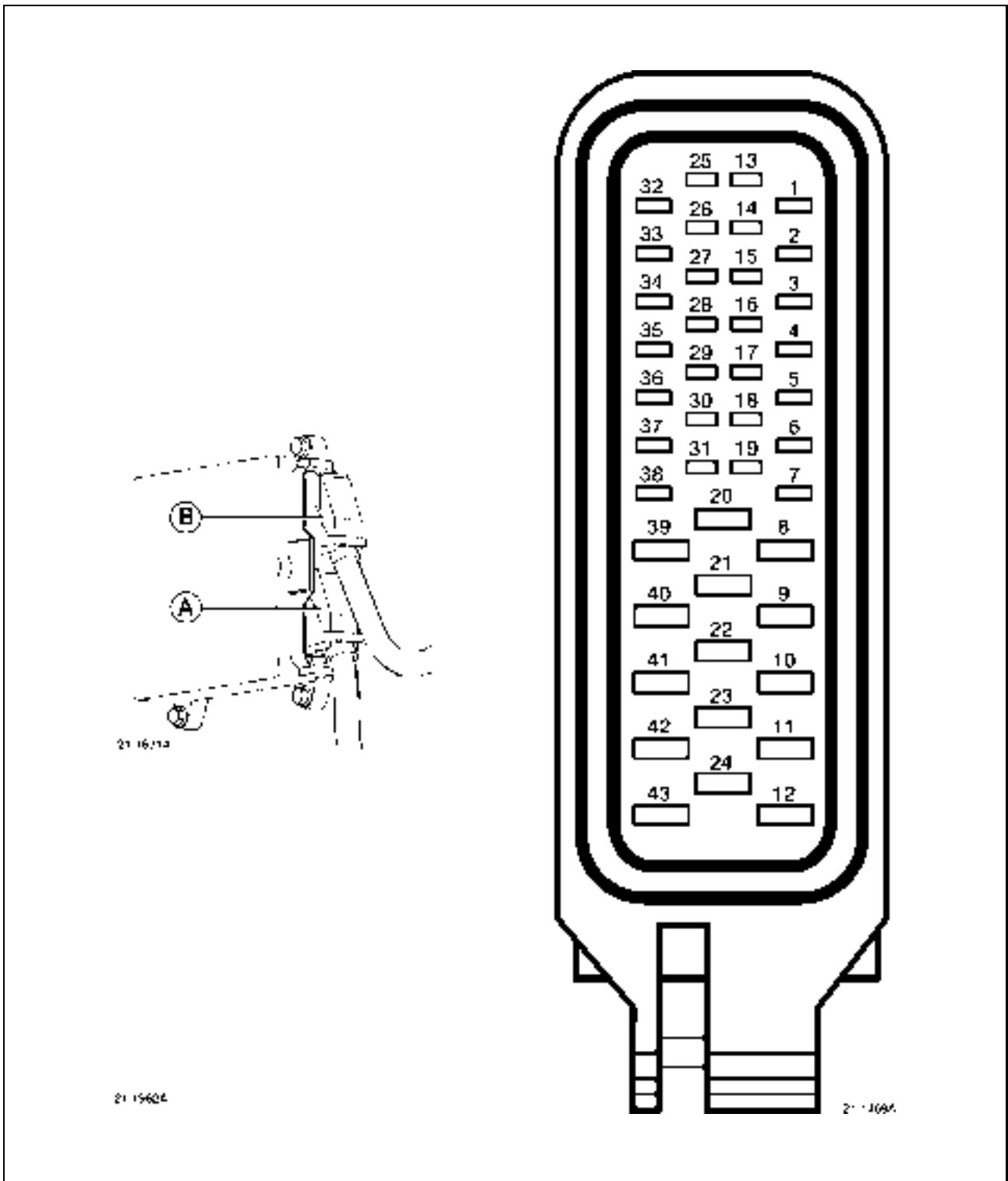

1 - 1 Engine oil pressure sensor

Major fault

Repercussion:

- Drop in engine power of **20 %** (injection pressure limited to **1000 bars**).
- Default value: oil pressure = **6 bars**.

Test:

- Correct operation of sensor using the RENAULT TRUCKS diagnostics tool DIAGNOSTICA.
- Continuity of engine wiring harness between:
 - Terminal **A5** of the ECU connector and terminal **C** of the sensor connector.
 - Terminal **A18** of the ECU and terminal **A** of the sensor connector.
 - Terminal **A26** of the ECU and terminal **B** of the sensor connector.
- Insulation of each wire.
- Sensor current supply (ECU connected, ignition switched on):
 - Presence of + **5 Volts** at terminal **B** of the sensor connector.
 - Presence of earth ($R < 10 \Omega$) at sensor connector terminal **A**.

1 - 3 Boost air pressure sensor

Minor fault

Repercussion:

- Drop in engine power of **5 %** (injection pressure limited to **1300 bars**).
- Default value: boost air pressure = **1013 mbars**.

Test:

- Resistance at sensor terminals (at **20 °C**) between:
 - Between terminals **3** and **4**: $R = 3400 \rightarrow 8200 \Omega$.
 - Between terminals **3** and **1**: $R = 2400 \rightarrow 8200 \Omega$.
- Continuity of engine wiring harness between:
 - Terminal **A19** of the ECU connector and terminal **1** of the sensor connector.
 - Terminal **A3** of the ECU connector and terminal **3** of the sensor connector.
 - Terminal **A34** of the ECU connector and terminal **4** of the sensor connector.
- Insulation of each wire.
- Sensor current supply (ECU connected, ignition switched on):
 - Presence of + **5 Volts** at terminal **3** of the sensor connector.
 - Presence of earth ($R < 10 \Omega$) at sensor connector terminal **1**.

1 - 5 Engine cooling circuit temperature sensor

Minor fault

Repercussion:

- Drop in engine power of **5 %** (injection pressure limited to **1300 bars**).
- Default value: coolant temperature = engine oil temperature

Test:

- Resistance of sensor (see "Technical data" chapter for the values)
- Continuity of engine wiring harness between:
 - Terminal **A30** of the ECU connector and terminal **2** of the sensor connector.
 - Terminal **A1** of the ECU connector and terminal **1** of the sensor connector.
- Insulation of each wire.
- Sensor current supply (ECU connected, ignition switched on):
 - Presence of + **5 Volts** at terminal **1** of the sensor connector.
 - Presence of earth ($R < 10 \Omega$) at sensor connector terminal **2**.

1 - 6 Boost air temperature sensor

Minor fault

Repercussion:

- Drop in engine power of **5 %** (injection pressure limited to **1300 bars**).
- Default value: boost air temperature = **40 °C**.

Test:

- Resistance of sensor (see "Technical data" chapter for the values)
- Continuity of engine wiring harness between:
 - Terminal **A19** of the ECU connector and terminal **1** of the sensor connector.
 - Terminal **A2** of the ECU connector and terminal **2** of the sensor connector.
- Insulation of each wire.
- Sensor current supply (ECU connected, ignition switched on):
 - Presence of earth ($R < 10 \Omega$) at sensor connector terminal **1**.
 - Presence of **+ 5 Volts** at terminal **2** of the sensor connector.

1 - 7 Engine oil temperature sensor

Minor fault

Repercussion:

- Drop in engine power of **5 %** (injection pressure limited to **1300 bars**).
- Default value: engine oil temperature = **90°C**.

Test:

- Resistance of sensor (see "Technical data" chapter for the values)
- Continuity of engine wiring harness between:
 - Terminal **A16** of the ECU connector and terminal **1** of the sensor connector.
 - Terminal **A19** of the ECU connector and terminal **2** of the sensor connector.
- Insulation of each wire.
- Sensor current supply (ECU connected, ignition switched on):
 - Presence of **+ 5 Volts** at terminal **1** of the sensor connector.
 - Presence of earth ($R < 10 \Omega$) at sensor connector terminal **2**.

1 - 9 Engine oil level sensor

Minor fault

Repercussion:

- Drop in engine power of **5 %** (injection pressure limited to **1300 bars**).
- Default value: engine oil system empty.

Test:

- Resistance of sensor (see "Technical data" chapter for the values)
- Continuity of engine wiring harness between:
 - Terminal **A17** of the ECU connector and terminal **2** of the sensor connector.
 - Terminal **A38** of the ECU connector and terminal **1** of the sensor connector.
- Insulation of each wire.

2 - 1 Declutching fan speed sensor

Minor fault

Repercussion:

- Drop in engine power of **5 %** (injection pressure limited to **1300** bars).
- Cooling fan driven at maximum speed.

Test:

- Continuity of vehicle wiring harness between:
 - Terminal **B34** of the ECU connector and terminal **1** of the fan clutch connector.
 - Terminal **B14** of the ECU connector and terminal **2** of the fan clutch connector.
 - Terminal **B4** of the ECU connector and terminal **3** of the fan clutch connector.
- Insulation of each wire.
- Sensor current supply (ECU connected, ignition switched on):
 - Presence of earth at terminal **1** of the sensor connector.
 - Presence of + **5 Volts** at terminal **2** of the sensor connector.

2 - 2 → 2 - 3 Speed sensors

2 - 2 Flywheel speed sensor

2 - 3 High pressure pump speed sensor

Minor fault

Repercussion:

- Drop in engine power of **20 %** (injection pressure limited to **1000** bars)
- Longer starting time (about 6 seconds)

Test:

- Resistance at sensor terminals (at **20°C**): **R = 770 → 950 Ω**
- Insulation of each wire.

Flywheel speed sensor

- Continuity of vehicle wiring harness between:
 - Terminal **A29** of the ECU connector and terminal **1** of the sensor connector.
 - Terminal **A37** of the ECU connector and terminal **2** of the sensor connector.

High pressure pump rotating speed sensor

- Continuity of vehicle wiring harness between:
 - Terminal **A4** of the ECU connector and terminal **2** of the sensor connector.
 - Terminal **A31** of the ECU connector and terminal **1** of the sensor connector.

2 - 4 Fuel high pressure sensor

Major fault

Repercussion:

- Drop in engine power of **50 %** (injection pressure limited to **850** bars)
- Injection pressure maximum value regulated by the rail pressure limiter

Test:

- Operation of the sensor should only be tested using the RENAULT TRUCKS diagnostic tool DIAGNOSTICA.
- Continuity of vehicle wiring harness between:
 - Terminal **A6** of the ECU connector and terminal **1** of the sensor connector.
 - Terminal **A33** of the ECU connector and terminal **2** of the sensor connector.
 - Terminal **A13** of the ECU connector and terminal **3** of the sensor connector.
- Insulation of each wire.
- Sensor current supply (ECU connected, ignition switched on):
 - Presence of earth ($R < 10 \Omega$) at sensor connector terminal **1**.
 - Presence of + **5 Volts** at terminal **3** of the sensor connector.



Replace the rail pressure regulator without fail.

2 - 5 Sensors "+" 5 Volts current supply fault

Major fault

Repercussion:

- Drop in engine power of **20 %** (injection pressure limited to **1000 bars**)
- Operation of sensors in fall-back mode.

Test:

- Presence of **+ 5 Volts** at the sensor terminals (ECU connected, ignition switched on):
 - Terminal **B** of the engine oil pressure sensor.
 - Terminal **3** of the injection pressure sensor.
 - Terminal **3** of the boost air pressure sensor.
 - Terminal **1** of the cooling fan clutch sensor.
- Continuity of engine wiring harness between:
 - Terminal **A26** of the ECU connector and terminal **B** of the engine oil pressure sensor connector.
 - Terminal **A13** of the ECU connector and terminal **3** of the injection pressure sensor connector.
 - Terminal **A3** of the ECU connector and terminal **3** of the boost air pressure sensor connector.
- Continuity of vehicle wiring harness between:
 - Terminal **B34** of the ECU connector and terminal **1** of the fan clutch connector.
- Insulation of each wire.

2 - 8 Engine stop control (cab tilted)

Minor fault

Repercussion:

- Drop in engine power of **5 %** (injection pressure limited to **1300 bars**)
- Operating failure of the engine stop function with the switch

Test:

- Correct operation of switch:
 - Switch contacts open in the rest position.
 - Switch contacts closed when the button is depressed.
 - Button returns to rest position under effect of return spring.
- Switch current supply (ECU connected, ignition switched on):
 - Presence of **+ 24 Volts** at terminal **1** of the switch connector.
- Continuity of vehicle wiring harness between:
 - ECU connector terminal **B32** and switch terminal **2**.
 - ECU connector terminal **B22 B9** and switch terminal **1**.
- Insulation of each wire.

3 - 2 Exhaust brake electrovalve

Open-circuit or short-circuit to + 24 Volts current supply

Minor fault

Repercussion:

- Drop in engine power of **50 %** (injection pressure limited to **850 bars**)
- Operating failure of the exhaust brake function

Short-circuit to earth

Major fault

Repercussion:

- Drop in engine power of **50 %** (injection pressure limited to **850 bars**)
- Exhaust brake strangler jammed in closed position

Test:

- Resistance of electrovalve winding (at **20°C**): **R = 41.5 → 48.5 Ω**
- Continuity of vehicle wiring harness between:
 - Terminal **B42** of the ECU connector and terminal **1** of the electrovalve.
 - Terminals **B22** and **B9** of the ECU connector and terminal **2** of the electrovalve.
- Electrovalve current supply (ECU connected, ignition switched on):
 - Presence of **+ 24 Volts** at terminal n° **2** of the electrovalve connector
- Insulation of each wire.

3 - 3 → 3 - 4 Jake brake solenoid valves

3 - 3 Jake brake solenoid valve N° 1

3 - 4 Jake brake solenoid valve N° 2

Line open-circuit or short-circuit to earth

Minor fault

Repercussion:

- Drop in engine power of **50 %** (injection pressure limited to **850 bars**)
- Operating failure of the exhaust brake function

Line short-circuit to + 24 Volts

Major fault

Repercussion:

- Drop in engine power of **50 %** (injection pressure limited to **850 bars**)
- Retarder operating on 3 cylinders only

Test:

- Resistance of solenoid valve winding (at **20°C**): **R = 32 → 40 Ω**
- Continuity of engine wiring harness between:

Solenoid valve N° 1

- Terminal **A8** of the ECU connector and wire **1007** connector on the solenoid valve.
- Terminal **A32** of the ECU connector and wire **2026** connector on the solenoid valve.

Solenoid valve N° 2

- Terminal **A8** of the ECU connector and wire **1007** connector on the solenoid valve.
- Terminal **A27** of the ECU connector and wire **2027** connector on the solenoid valve.
- Insulation of each wire (both solenoid valves disconnected)

3 -7 Declutching fan speed regulation solenoid valve

Line open-circuit or short-circuit to + 24 Volts

Minor fault

Repercussion:

- Drop in engine power of **5 %** (injection pressure limited to **1300 bars**)
- Cooling fan driven at maximum speed

Line short-circuit to earth

Major fault

Repercussion:

- Drop in engine power of **20 %** (injection pressure limited to **1000 bars**)
- Cooling fan driven at maximum speed

Test:

- Solenoid valve resistance between terminals **4** and **5** of the fan clutch connector (at **20°C**): **R = 55 → 65 Ω**
- Continuity of vehicle wiring harness between:
 - Terminal **B11** of the ECU connector and terminal **4** of the fan clutch connector.
 - Terminals **B22** and **B9** of the ECU connector and terminal **5** of the fan clutch connector.
- Solenoid valve current supply (ECU connected, ignition switched on):
 - Presence of **+ 24 Volts** at terminal **5** of the fan clutch connector.
- Insulation of each wire.

4 - 1 → 4 - 6 Fuel injectors

4 - 1 N° 1 cylinder fuel injector

4 - 2 N° 2 cylinder fuel injector

4 - 3 N° 3 cylinder fuel injector

4 - 4 N° 4 cylinder fuel injector

4 - 5 N° 5 cylinder fuel injector

4 - 6 N° 6 cylinder fuel injector

Flow limiter jammed

Minor fault

Repercussion:

- Impairment of engine performance of around **16 %** (injection pressure not limited)
- Operating failure of fuel injector in question

Test:

- For absence of leaks on circuit between rail and injector
- Operation of fuel injector on test bench

Electrical system open-circuit

Minor fault

Repercussion:

- Operating failure of fuel injector in question
- Impairment of engine performance of around **16 %** (injection pressure not limited)

Test:

Resistance of fuel injector solenoid valve winding (at **20°C**): **R = 0.3 → 0.5 Ω**

- Continuity of engine wiring harness between:
 - Terminals **B40** and **B41** of the ECU connector and wire **173** at the terminals of fuel injectors N° **1/2/3**
 - Terminals **B42** and **B43** of the ECU connector and wire **173** at the terminals of fuel injectors N° **4/5/6**
 - ECU connector terminal **A12** and N° **1** injector terminal wire **293**.
 - ECU connector terminal **A11** and N° **2** injector terminal wire **295**.
 - ECU connector terminal **A24** and N° **3** injector terminal wire **294**.
 - ECU connector terminal **A22** and N° **4** injector terminal wire **298**.
 - ECU connector terminal **A23** and N° **5** injector terminal wire **296**.
 - ECU connector terminal **A10** and N° **6** injector terminal wire **297**.

Electrical system short-circuit

Major fault

Repercussion:

- Operating failure of N° **1/2/3** cylinder injectors or N° **4/5/6** cylinder injectors
- Impairment of engine performance of around **50 %** (injection pressure not limited)

Test:

- Insulation of wires (injector in question disconnected)

5 - 1 → 5 - 2 Fuel flow regulation solenoid valve

5 - 1 Fuel flow regulation solenoid valve N° 1

5 - 2 Fuel flow regulation solenoid valve N° 2

Line open-circuit or short-circuit to earth

Major fault

Repercussion:

- Drop in engine power of **50 %** (injection pressure limited to **850 bars**)
- Flow regulation ensured by non-defective solenoid valve
- High injection pressure (defective solenoid valve jammed in the open position)
- Injection pressure maximum value regulated by the rail pressure limiter

Line short-circuit to + 24 Volts

Major fault

Repercussion:

- Drop in engine power of **50 %** (injection pressure limited to **850 bars**)
- Flow regulation ensured by non-defective solenoid valve
- High injection pressure (defective solenoid valve jammed in the closed position)

Test:

- Resistance of solenoid valve winding (at **20°C**): **R = 14 → 16 Ω**

Solenoid valve N° 1

- Continuity of engine wiring harness between:
 - Terminal **A9** of the ECU connector and terminal **1** of the solenoid valve.
 - Terminal **A20** of the ECU connector and terminal **2** of the solenoid valve.

Solenoid valve N° 2

- Continuity of engine wiring harness between:
 - Terminal **A7** of the ECU connector and terminal **2** of the solenoid valve.
 - Terminal **A21** of the ECU connector and terminal **1** of the solenoid valve.



Replace the rail pressure regulator without fail.

5 - 3 Injection pressure outside operating band

Major fault

Repercussion:

- Drop in engine power of **50 %** (injection pressure limited to **850 bars**)
- Operation with a random rail pressure
- Injection pressure maximum value regulated by the rail pressure limiter

Test:

Fuel aspiration system.

- for leaks.
- for fouling (especially the prefilter).

Low pressure circuit.

- for leaks.
- correct operation of booster pump.
- for fouling (especially the filters).

High pressure circuit.

- for leaks.
- correct operation of high pressure pump.
- correct operation of fuel flow regulation solenoid valves.
- rail leak-off return circuit.
- correct operation of flow limiters.
- correct operation of fuel injectors.



Replace the rail pressure regulator without fail if the injection pressure is too high.

5 - 5 Battery charge voltage incorrect

18.5 V < Battery voltage > 34 V

Minor fault

Repercussion:

- Drop in engine power of **20 %** (injection pressure limited to **1000 bars**)

Test:

- Correct operation of charging system
 - Charge voltage
 - Voltage regulator
 - Conformity, condition and connection of charging system
 - Condition and connection of batteries

5 - 6 Communication line between engine and vehicle ECUs (CAN BUS)

Major fault

Repercussion:

- Engine speed permanently steady at **900 rpm**.

Test:

- Continuity of vehicle wiring harness between:
 - Terminal **B8** of the fuel-injection ECU and terminal **7** of the vehicle VECU connector (green wire).
 - Terminal **B20** of the fuel injection ECU connector and terminal **8** of the vehicle ECU connector (white wire).
 - Terminal **B39 6** of the vehicle VECU connector (red wire).
- Insulation of each wire.
- ECU current supply (vehicle ECU connected):
 - Presence of earth at injection ECU connector terminals **B12, B24, B43**.
 - Presence of after ignition + at terminals **B9, B22, B10, B41**.

5 - 8 Engine master ECU fault

Internal fault

Major fault

Repercussion:

- Operating failure of N° **1 /2/3** cylinder injectors or N° **4/5/6** cylinder injectors
- Drop in engine power of **20 %** (injection pressure limited to **1000 bars**)

Memory fault or fault memorizing procedure fault

Minor fault

- Drop in engine power of **20 %** (injection pressure limited to **1000 bars**)
- No memorizing of faults

5 - 9 Engine ECU power supply relay (R40)

Presence of relay R40 in fuses/relays box:

Minor fault

Repercussion:

- Relay continuously supplied with current
- Drop in engine power of **20 %** (injection pressure limited to **1000 bars**)

Test:

- Correct operation of relay (relay raised slightly so as to measure its terminal voltages):
 - Ignition switched off: absence of voltage at terminal **87** of the relay
 - Ignition switched on: presence of voltage (+ **24 Volts**) at terminal **87** of the relay
- Correct operation of relay (relay removed):
 - Winding not supplied with current: contact open between terminal **30** and **87** of the relay
 - Winding supplied with current (+ **24 Volts**) at terminal **86** and earth at terminal **85** of the relay: contact closed between terminals **30** and **87** of the relay
- Continuity of engine wiring harness between:
 - Terminals **A9** and **A10** of the vehicle VECU and terminal **87** of the relay
 - Terminals **B9**, **B22** and **B41** of the fuel-injection ECU connector.
- Continuity of vehicle wiring harness between:
 - Terminal **9** of the 15-way black connector of the vehicle VECU terminal **85** of the relay connector.

6 - 1 Accelerator pedal position sensor

Major fault

Repercussion:

- Engine speed permanently steady at **900 rpm**.

Test:

- Pedal sensor characteristics
 - Between terminals **1** and **6**, test the resistance: $R = 2300 \Omega$
 - Between terminals **1** and **3**, then between terminals **3** and **6**, test the linear variation of the resistance as a function of the pedal travel.
- Pedal high position signal microswitch
 - Pedal in high position, test closing of contact between terminals **2** and **5** of the sensor.
 - Pedal in acceleration mid-travel position, test opening of contact between terminals **2** and **5** of the sensor.
- Sensor current supply
 - Presence of earth at terminal **2** of the vehicle wiring harness connector.
 - Presence of + **5 Volts** at terminal **1** of the vehicle wiring harness.
 - Presence of + **24 Volts** at terminal **5** of the vehicle wiring harness connector.
- Continuity of dashboard wiring harness between:
 - Terminal N° **1** of the black connector **18** and sensor connector terminal **5**.
 - Terminal N° **3** of the black connector **18** and sensor connector terminal **6**.
 - Terminal N° **4** of the black connector **18** and sensor connector terminal **1**.
 - Terminal N° **5** of the black connector **18** and sensor connector terminal **3**.

6 - 5 Cruise control

Minor fault

Repercussion:

- Operating failure of cruise control, idling speed adjustment and fast idling functions

Test:

- Correct operation of cruise control:
 - Control switch in position "**ON**", contact closed between terminals **B5** and **B6**
 - Control switch in position "**OFF**", contact open between terminals **B5** and **B6**
 - Control switch in position "**R/+**", contact closed between terminals **B7** and **B2**
 - Control switch in position "**S/-**", contact closed between terminals **B1** and **B2**
 - Control switch in position "**O**", contact open between terminals **B1** and **B2** and terminals **B7** and **B2**
- Continuity of wiring harness
- The control connector is the one connected directly to the cruise control
- Continuity of dashboard wiring harness between:
 - VECU **18**-way black connector terminal **6** and control connector terminal **B5**.
 - VECU **18**-way black connector terminal **7** and control connector terminal **B1**.
 - VECU **18**-way black connector terminal **8** and control connector terminal **B7**.
- Control current supply
 - Presence of earth at control connector terminal **B2**.
 - Presence of + **24 Volts** at terminals **B1**, **B5** and **B7** of the control switch connector.

DIAGNOSTICS AID (SETTING +J01)

Diagnostic (dCi 11 +J01)

Instrument panel indicator lights

Indicator lights (1 - 2 - 3 - 4) inform the driver on the state of the system and on the kind of faults possibly detected or memorized. Warning light (1) indicates a major fault and requires the vehicle to be stopped immediately.

Warning light (2) indicates a minor fault.

Tell-tale light (3) indicates that the fault originates from a component managed by the engine master electronic control unit (EECU).

Tell-tale light (4) indicates that the fault originates from a component managed by the vehicle master electronic control unit (VECU).

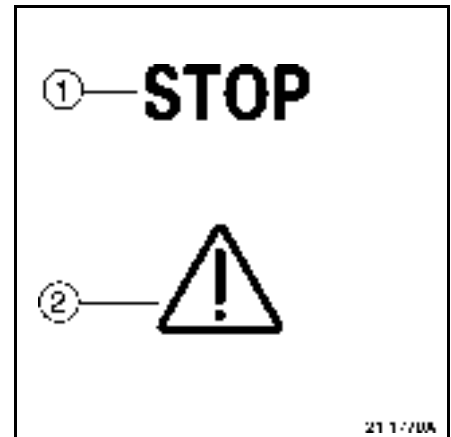

The system functions by virtue of default values that replace values that can no longer be measured. Certain functions may be inhibited or operate in fall-back mode.

In all cases, the fuel-injection system needs urgent maintenance.

In the case of detection of fault, engine performance may be impaired.

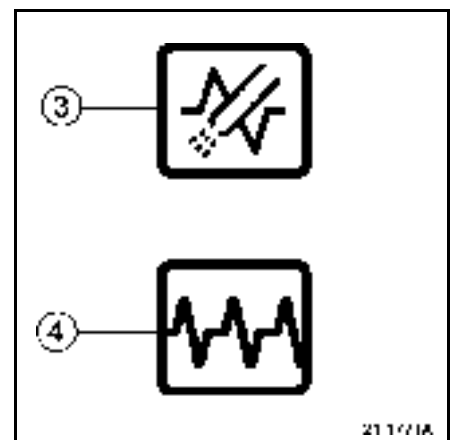

Faults can be visualized by using the RENAULT TRUCKS diagnostics tool DIAGNOSTICA plugged into the vehicle diagnostics socket (5) .

Faults can also be visualized on the instrument panel information display with the display of code numbers in the "present faults" or "memorized faults" sub-menus

After taking action, erase the fault code numbers using the RENAULT TRUCKS diagnostics tool DIAGNOSTICA.

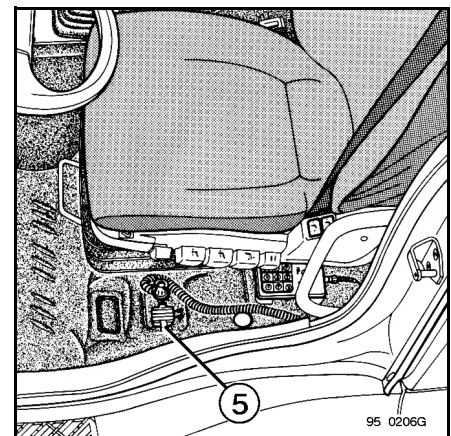

Use of the RENAULT TRUCKS diagnostic tool DIAGNOSTICA

The use of this tool provides great ease of diagnostics and its employment is strongly recommended. It is absolutely essential for erasing faults. Plug the diagnostics tool into the socket.

Available functions:

1/ Present faults

- component
- fault
- remedies

2/ Memorized faults

- component
- fault
- remedies
- erasure

3/ Diagnostic

- Diagnostics according to function
 - Exhaust brake
 - Declutching fan
 - Injection pressure
 - PTO
 - Warm-up
 - Exhaust brake strangler
- Visualization of inputs (digital displays and/or graphics of next values)
 - Engine operating time
 - Accelerator pedal position (%)
 - Battery voltage
 - Engine oil level
 - Coolant temperature
 - Boost air temperature
 - Atmospheric pressure
 - Engine oil pressure
 - Boost air pressure
 - Injection pressure
 - Engine speed
 - Vehicle road speed
 - Declutching fan speed
 - Injected fuel quantity
 - Injection timing
 - Exhaust brake presence
 - Jake brake presence
 - Exhaust brake pilot-control set-point
 - Air conditioning system in operation
 - Fast idling speed set-point (PTO)



The values for adjusting the accelerator pedal position are shown in the "VECU" menu.

Diagnostics using instrument panel display

Controls

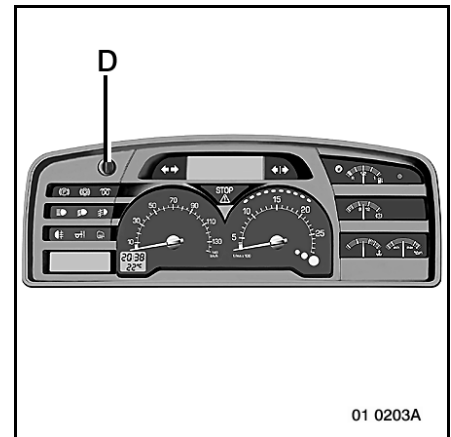

You are advised to use button (D) while the vehicle is stationary and correctly parked.

Button (D):

Push towards (+) or (-)

- to gain access to the different menus and sub-menus
- to make an adjustment or choice in the opened menu

Short pulses (V):

- open a selected menu.
- validate an adjustment or a choice in the menu selected
- scroll through present or memorized faults in succession

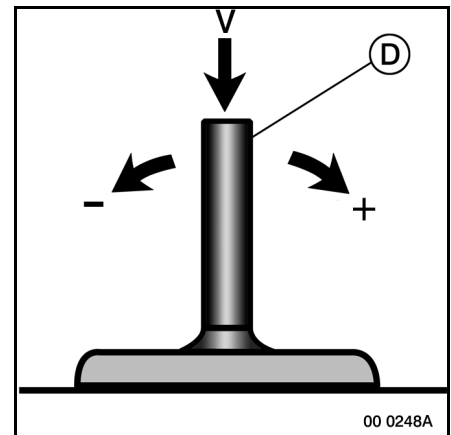

Button (AE):

Short pulses:

- serve to go back to the default display.
- close an opened menu without validating the adjustment or choice
- display the driver's various supplementary driving menus

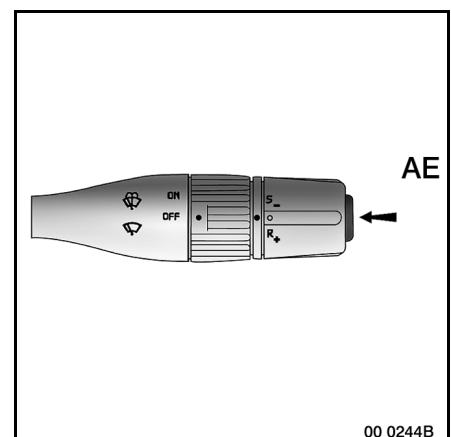

Meaning of fault codes

- **A:** Fault code.
- **B:** Fault type.

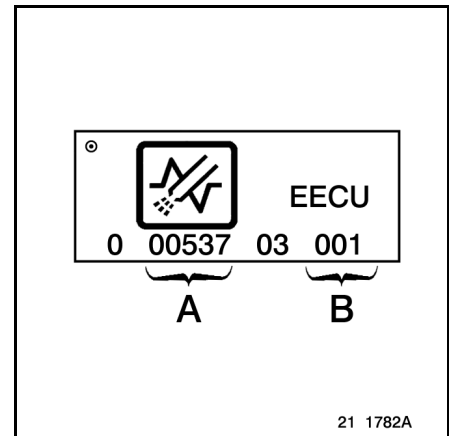

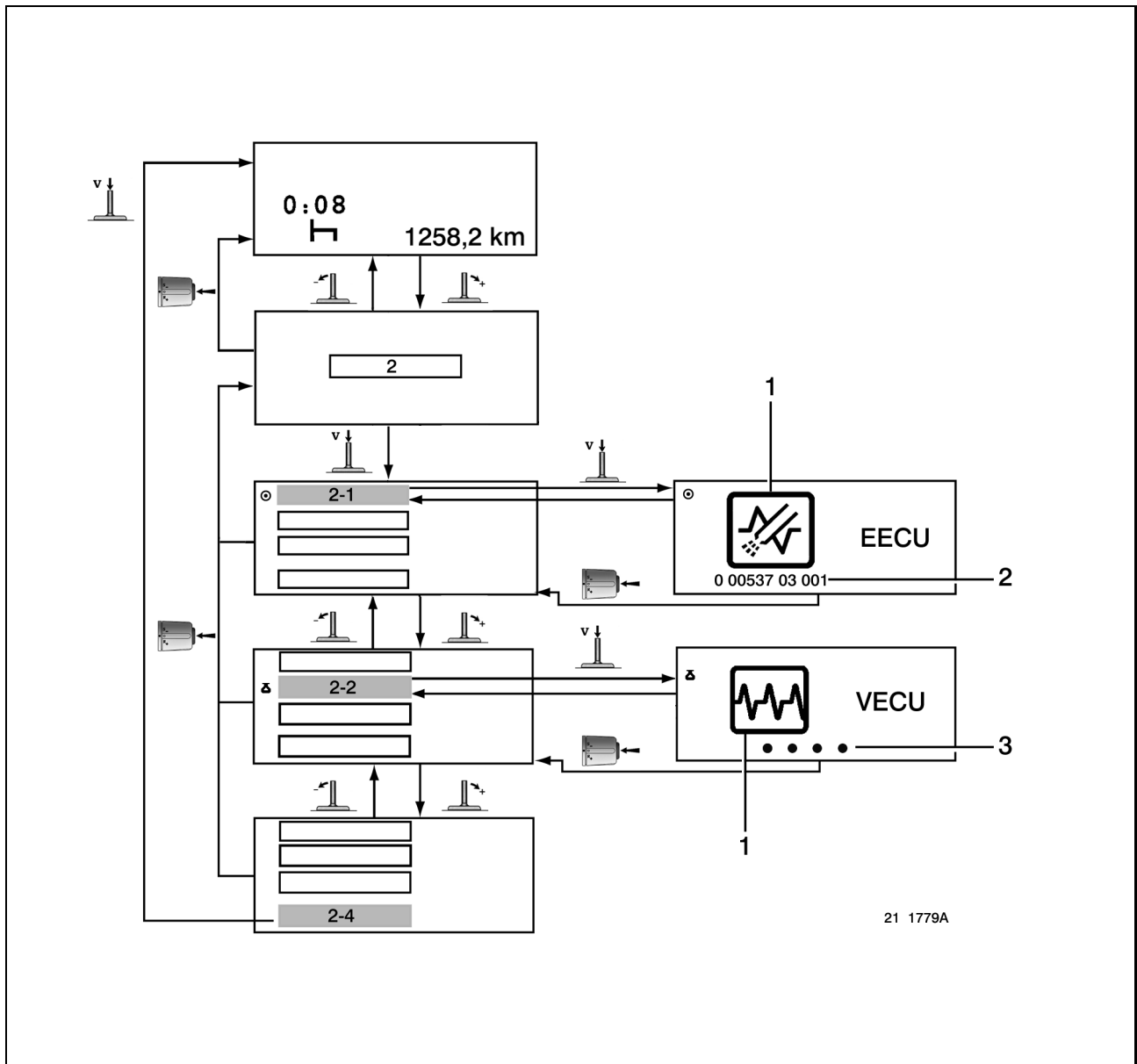

Select the diagnostics menu (2)

When the menu is open, the **STOP** warning light comes on.

Sub-menus

- 2-1: Present faults
- 2-2: Memorized faults
- 2-4: Quit

In all cases, pictogram (1) indicates the function concerned. To obtain the desired function, use control (D) whenever necessary.

For "present faults" and "memorized faults" sub-menus, code number (2) characterizes the fault, or 4 dots (3) mean there are no faults.

List of fault code numbers



The repercussion of the fault code numbers listed hereafter is only significant in the event of one single fault being present. If there are several present faults, the impairment of the system features provided may be greater and lead to operating impossibility.

Only code numbers specific to fuel-injection are covered in this document.

Faults relative to other functions may impair the features provided by the fuel-injection system (refer to the workshop manual sections corresponding to the systems incriminated).

To perform more comprehensive diagnostics on vehicle wiring harness runs, refer to the "PREMIUM Electrics" or "KERAX Electrics" workshop manual section for the vehicle.

Recap table of fault code numbers

Fault code	Nature of incident	See page
513	Parameter definition	L-10
529	Engine oil pressure sensor	L-10
530	Fuel filters clogging sensor	L-10
531	Boost air pressure sensor	L-11
533	Engine cooling circuit temperature sensor	L-11
534	Boost air temperature sensor	L-11
537	Engine oil level sensor	L-12
545	Declutching fan speed sensor	L-12
546	Flywheel speed sensor	L-12
547	High pressure pump rotating speed sensor	L-13
551	Clogged fuel filters	L-13
552	Engine stop control (cab tilted)	L-13
562	Exhaust brake electrovalve	L-14
563	Jake brake solenoid valve N° 1	L-14
564	Jake brake solenoid valve N° 2	L-14
565	Starter	L-14
567	Declutching fan speed regulation solenoid valve	L-15
568	Starting devices	L-15
577	N°1 cylinder fuel injector	L-16
578	N°2 cylinder fuel injector	L-16
579	N°3 cylinder fuel injector	L-16
580	N°4 cylinder fuel injector	L-16
581	N°5 cylinder fuel injector	L-16
582	N°6 cylinder fuel injector	L-16
597	Battery charge voltage incorrect	L-16
600	Engine ECU fault	L-17

Fault code	Nature of incident	See page
613	Cruise-control switch	L-17
804	Fuel high pressure sensor	L-18
805	Sensors "+" 5 Volts current supply fault	L-18
818	Exhaust brake electrovalve	L-19
819	Jake brake solenoid valve N° 1	L-19
820	Jake brake solenoid valve N° 2	L-19
821	Starter	L-20
824	Starting devices	L-20
833	N°1 cylinder fuel injector	L-20
834	N°2 cylinder fuel injector	L-20
835	N°3 cylinder fuel injector	L-20
836	N°4 cylinder fuel injector	L-20
837	N°5 cylinder fuel injector	L-20
838	N°6 cylinder fuel injector	L-20
849	Fuel flow regulation solenoid valve N°1	L-21
850	Fuel flow regulation solenoid valve N°2	L-21
851	Injection pressure outside normal operating band	L-22
853	Battery charge voltage incorrect	L-22
854	Communication line between engine and vehicle ECUs (CAN bus)	
856	Engine ECU fault	L-23
865	Accelerator pedal	L-23

Assignment of pins to ECU wiring harness connector

(Connector face view)

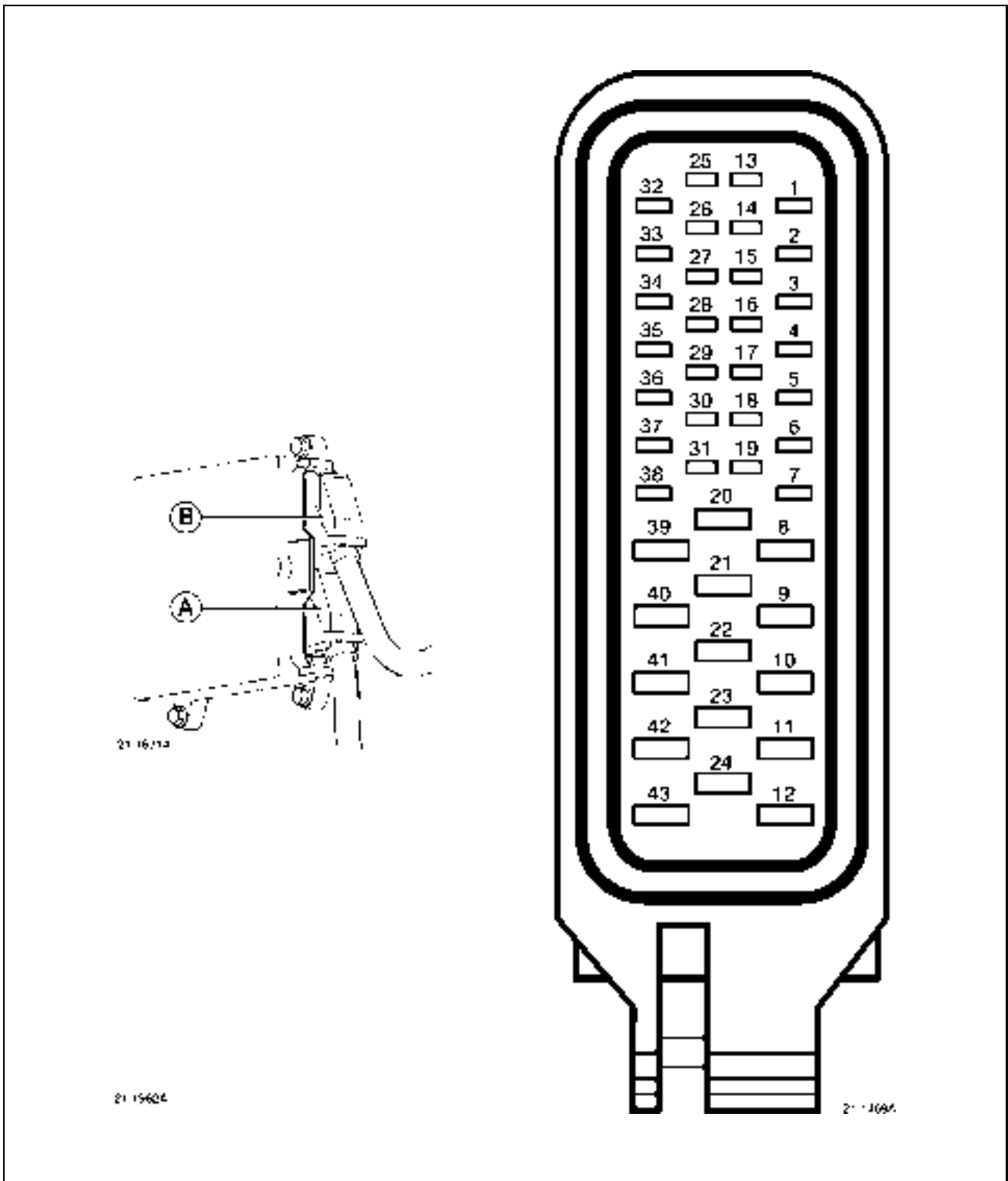

513 Parameter definition

Display message

- PARAMETER DEFINITION

Minor fault

- Parameters of ECU supplied by BOSCH not redefined by RENAULT TRUCKS.

Repercussion:

- No drop in engine power

Remedy:

- Define the EECU parameters.

529 Engine oil pressure sensor

Display message

- SENSOR FAULT.

Minor fault

Repercussion:

- No drop in engine power
- Default value: oil pressure = **6 bars**.

Test:

- Correct operation of sensor using the RENAULT TRUCKS diagnostics tool DIAGNOSTICA.
- Continuity of engine wiring harness between:
 - ECU connector terminal **A5** and sensor connector terminal **C**.
 - ECU connector terminal **A18** and sensor connector terminal **A**.
 - ECU connector terminal **A26** and sensor connector terminal **B**.
- Insulation of each wire.
- Sensor current supply (ECU connected, ignition switched on):
 - Presence of + **5 Volts** at terminal **B** of the sensor connector.
 - Presence of earth ($R < 10 \Omega$) at sensor connector terminal **A**.

530 Fuel filters clogging sensor

Display message

- WORKSHOP STOP.

Minor fault

Repercussion:

- No drop in engine power

Test:

- Correct operation of switch:
 - Switch contacts open in the rest position.
 - Switch contacts open when **P1 \geq 3 bars P2**.
 - Button returns to rest position under effect of return spring.
- Switch current supply (ECU connected, ignition switched on):
 - Presence of + **24 Volts** at one of the switch connector terminals (wire **292**).
- Continuity of vehicle wiring harness between:
 - **EECU** connector terminal **B33** and one of the sensor terminals (wire **8072**).
 - **EECU B9, B22 B32** and one of the sensor terminals (wire **292**).
- Insulation of each wire.

531 Boost air pressure sensor

Display message

- WORKSHOP STOP.

Minor fault

Repercussion:

- Protection mode (low output)
- Default value: boost air pressure = **1013 mbar(s)**.
- Default value: atmospheric air pressure = **0 mbar(s)**.

Test:

- Resistance at sensor terminals (at **20 °C**) between:
 - Between terminals **3** and **4**: $R = 3400 \rightarrow 8200 \Omega$.
 - Between terminals **3** and **1**: $R = 2400 \rightarrow 8200 \Omega$.
- Continuity of engine wiring harness between:
 - ECU connector terminal **A19** and sensor connector terminal **1**.
 - ECU connector terminal **A3** and sensor connector terminal **3**.
 - ECU connector terminal **A34** and sensor connector terminal **4**.
- Insulation of each wire.
- Switch current supply (ECU connected, ignition switched on):
 - Presence of + **5 Volts** at terminal **3** of the sensor connector.
 - Presence of earth ($R < 10 \Omega$) at sensor connector terminal **1**.

533 Engine cooling circuit temperature sensor

Display message

- SENSOR FAULT.

Minor fault

Repercussion:

- Protection mode.
- Default value: coolant temperature = **98 °C**.

Test:

- Resistance of sensor (see "Technical data" chapter for the values)
- Continuity of engine wiring harness between:
 - ECU connector terminal **A30** and sensor connector terminal **2**.
 - ECU connector terminal **A1** and sensor connector terminal **1**.
- Insulation of each wire.
- Sensor current supply (ECU connected, ignition switched on):
 - Presence of + **5 Volts** at sensor connector terminal **1**.
 - Presence of earth ($R < 10 \Omega$) at sensor connector terminal **2**.

534 Boost air temperature sensor

Display message

- WORKSHOP STOP.

Minor fault

Repercussion:

- Protection mode.
- Default value: boost air temperature = **60°C**

Test:

- Resistance of sensor (see "Technical data" chapter for the values)
- Continuity of engine wiring harness between:
 - ECU connector terminal **A19** and sensor connector terminal **1**.
 - ECU connector terminal **A2** and sensor connector terminal **2**.
- Insulation of each wire.
- Sensor current supply (ECU connected, ignition switched on):
 - Presence of earth ($R < 10 \Omega$) at sensor connector terminal **1**.
 - Presence of + **5 Volts** at terminal **2** of the sensor connector.

537 Engine oil level sensor

Display message

- SENSOR FAULT.

Minor fault

Repercussion:

- No drop in engine power
- Default value: engine oil circuit empty

Test:

- Resistance of sensor (see "Technical data" chapter for the values)
- Continuity of engine wiring harness between:
 - ECU connector terminal **A17** and sensor connector terminal **2**.
 - ECU connector terminal **A38** and sensor connector terminal **1**.
- Insulation of each wire.

545 Declutching fan speed sensor

Display message

- COOLING FAN INOPERATIVE

Minor fault

Repercussion:

- No drop in engine power
- Cooling fan driven at maximum speed
- Cut-off speed **1300** to **1400 rpm**.

Test:

- Continuity of vehicle wiring harness between:
 - Terminal **B34** of the ECU connector and terminal **1** of the fan clutch connector.
 - Terminal **B14** of the ECU connector and terminal **2** of the fan clutch connector.
 - Terminal **B4** of the ECU connector and terminal **3** of the fan clutch connector.
- Insulation of each wire.
- Sensor current supply (ECU connected, ignition switched on):
 - Presence of earth at terminal **1** of the sensor connector.
 - Presence of + **5 Volts** at terminal **2** of the sensor connector.

546 Flywheel speed sensor

Display message

- WORKSHOP STOP.

Minor fault

Repercussion:

- Drop in engine power (120 seconds after the information)
- Engine operation impaired if there is reversal of polarity
- Longer starting time (about 6 seconds)
- Operation on pump speed sensor

Test:

- Resistance at sensor terminals (at **20°C**): **R = 770 → 950 Ω**
- Insulation of each wire.
- Continuity of vehicle wiring harness between:
 - ECU connector terminal **A29** and sensor connector terminal **1**.
 - ECU connector terminal **A37** and sensor connector terminal **2**.

547 High pressure pump speed sensor

Display message

- WORKSHOP STOP.

Minor fault

Repercussion:

- No drop in engine power
- Longer starting time (about 6 seconds)
- Operation of engine speed sensor on flywheel

Test:

- Resistance at sensor terminals (at 20°C): $R = 770 \rightarrow 950 \Omega$
- Insulation of each wire.
- Continuity of vehicle wiring harness between:
 - ECU connector terminal **A4** and sensor connector terminal **2**.
 - ECU connector terminal **A31** and sensor connector terminal **1**.

551 Clogged fuel filters

Display message

- FUEL FILTERS

Minor fault

- No drop in engine power
- Cut-off speed **1300** to **1400 rpm**.

Test:

- Replace the fuel filters

552 Engine stop control (cab tilted)

Display message

- WORKSHOP STOP.

Minor fault

Repercussion:

- No drop in engine power
- Operating failure of the engine stop function with the switch

Test:

- Correct operation of switch:
 - Switch contacts open in the rest position.
 - Switch contacts closed when the button is depressed
 - Button returns to rest position under effect of return spring.
- Switch current supply (ECU connected, ignition switched on):
 - Presence of **24 Volts** at one of the switch connector terminals.
- Continuity of vehicle wiring harness between:
 - ECU connector terminal **B32** and switch terminal **2**.
 - ECU connector terminal **B22 B9** and switch terminal **1**.
- Insulation of each wire.

562 Exhaust brake electrovalve

Open-circuit or short-circuit to + 24 Volts current supply

Display message

- EXHAUST BRAKE INOPERATIVE

Minor fault

Repercussion:

- Drop in engine power (120 seconds after the information)
- Operating failure of the exhaust brake function

Test:

- Resistance of electrovalve winding (at 20°C): $R = 43 \rightarrow 49 \Omega$
- Continuity of vehicle wiring harness between:
 - Terminal **B42** of the ECU connector and terminal **1** of the electrovalve.
 - Terminals **B22** and **B9** of the ECU connector and terminal **2** of the electrovalve.
- Electrovalve current supply (ECU connected, ignition switched on):
 - Presence of + **24 Volts** at terminal n° **2** of the electrovalve connector
- Insulation of each wire.

563 → 564 Jake brake solenoid valves

563 Jake brake solenoid valve N° 1

564 Jake brake solenoid valve N° 2

Line open-circuit

Display message

- JAKE BRAKE INOPERATIVE

Minor fault

Repercussion:

- Drop in engine power (120 seconds after the information)
- Operating failure of the retarder function

Test:

- Resistance of solenoid valve winding (at 20°C): $R = 32 \rightarrow 40 \Omega$
- Continuity of engine wiring harness between:

Solenoid valve N° 1

- Terminal **A8** of the ECU connector and wire **1007** connector on the solenoid valve.
- Terminal **A32** of the ECU connector and wire **2026** connector on the solenoid valve.
- Insulation of each wire (both solenoid valves disconnected)

Solenoid valve N° 2

- Terminal **A8** of the ECU connector and wire **1007** connector on the solenoid valve.
- Terminal **A27** of the ECU connector and wire **2027** connector on the solenoid valve.
- Insulation of each wire (both solenoid valves disconnected)

565 Starter

Open-circuit or short-circuit to + 24 Volts current supply

Display message

- STARTER INOPERATIVE

Minor fault

- No drop in engine power
- No engine starting

Test:

- Continuity of vehicle wiring harness between:
 - Terminal **B11** of the ECU connector and wire **1077** connector on the relay.
 - Terminals **B9** and **B22** of the ECU connector and wire **292** connector on the relay.

567 Declutching fan speed regulation solenoid valve

Line open-circuit or short-circuit to + 24 Volts

Display message

- COOLING FAN INOPERATIVE

Minor fault

Repercussion:

- No drop in engine power
- Cooling fan driven at maximum speed

Line short-circuit to earth

Display message

- COOLING FAN INOPERATIVE

Minor fault

Repercussion:

- No drop in engine power
- Cooling fan driven at maximum speed

Test:

- Solenoid valve resistance between terminals **4** and **5** of the fan clutch connector (at **20°C**): $R = 55 \rightarrow 65 \Omega$
- Continuity of vehicle wiring harness between:
 - Terminal **B23** of the ECU connector and terminal **4** of the fan clutch connector.
 - Terminals **B22** and **B9** of the ECU connector and terminal **5** of the fan clutch connector.
- Solenoid valve current supply (ECU connected, ignition switched on):
 - Presence of + **24 Volts** at terminal **5** of the fan clutch connector.
- Insulation of each wire.

568 Starting aids

Open-circuit or short-circuit to + 24 Volts current supply

Display message

- PREHEATING INOPERATIVE

Minor fault

- No air preheating

Repercussion:

- Drop in engine power (120 seconds after the information)

Test:

- Continuity of engine wiring harness between:
 - ECU connector terminal **B11** and relay **R93** terminal **2**.
 - ECU connector terminal **A39** and relay **R93** terminal **1**.
 - Relay **R93** terminal **3** and resistance.
 - Resistance and earth.
 - Relay **R93** terminal **5** and +
- Insulation of each wire.

577 → 582 Fuel injectors

577 N° 1 cylinder fuel injector

578 N° 2 cylinder fuel injector

579 N° 3 cylinder fuel injector

580 N° 4 cylinder fuel injector

581 N° 5 cylinder fuel injector

582 N° 6 cylinder fuel injector

Electrical system open-circuit

Display message

- INJECTOR FAULT

Minor fault

Repercussion:

- Operating failure of fuel injector in question
- Injection pressure limited to **1000 bars**

Test:

Resistance of fuel injector solenoid valve winding (at 20°C): **R = 0.3 → 0.5 Ω**

- Continuity of engine wiring harness between:
 - Terminals **B40** and **B41** of the ECU connector and wire **173** at the terminals of fuel injectors N° **1/2/3**
 - Terminals **B42** and **B43** of the ECU connector and wire **174** at the terminals of fuel injectors N° **4/5/6**
 - ECU connector terminal **A12** and N° **1** injector terminal wire **293**.
 - ECU connector terminal **A11** and N° **2** injector terminal wire **295**.
 - ECU connector terminal **A24** and N° **3** injector terminal wire **294**.
 - ECU connector terminal **A22** and N° **4** injector terminal wire **298**.
 - ECU connector terminal **A23** and N° **5** injector terminal wire **296**.
 - ECU connector terminal **A10** and N° **6** injector terminal wire **297**.

597 Battery charge voltage incorrect

9.6 V < Battery voltage > 18.5 V

31 V < Battery voltage > 34 V

Display message

- WORKSHOP STOP.

Minor fault

Repercussion:

- No drop in engine power

Test:

- Correct operation of charging system
 - Charge voltage
 - Voltage regulator
 - Conformity, condition and connection of charging system
 - Condition and connection of batteries

600 Engine master ECU fault

Memory fault or fault memorizing procedure fault

Display message

- ENGINE FAULT

Minor fault

Repercussion:

- No drop in engine power
- No memorizing of faults

Engine / pump speed sensor acquisition interface fault

Display message

- ENGINE FAULT

Minor fault

Repercussion:

- Drop in engine power (120 seconds after the information)
- Erratic operation of the engine

Test:

EECU box using the RENAULT TRUCKS diagnostics tool DIAGNOSTICA.

613 Cruise control

Display message

- CRUISE CONTROL

Minor fault

Repercussion:

- Operating failure of cruise control, idling speed adjustment and fast idling functions

Test:

- Correct operation of cruise control:
 - Control switch in position "**ON**", contact closed between terminals **B5** and **B6**
 - Control switch in position "**OFF**", contact open between terminals **B5** and **B6**
 - Control switch in position "**R/+**", contact closed between terminals **B7** and **B2**
 - Control switch in position "**S/-**", contact closed between terminals **B1** and **B2**
 - Control switch in position "**O**", contact open between terminals **B1** and **B2** and terminals **B7** and **B2**
- Continuity of wiring harness
- The control connector is the one connected directly to the cruise control
- Continuity of dashboard wiring harness between:
 - VECU **18**-way black connector terminal **6** and control connector terminal **B5**.
 - VECU **18**-way black connector terminal **7** and control connector terminal **B1**.
 - VECU **18**-way black connector terminal **8** and control connector terminal **B7**.
- Control current supply
 - Presence of earth at control connector terminal **B2**.
 - Presence of + **24 Volts** at terminals **B1**, **B5** and **B7** of the control switch connector.

804 High pressure fuel sensor

Display message

- IMMEDIATE STOP

Major fault

Repercussion:

- No drop in engine power
- Default pressure mapping (**1500 bars**)
- Cut-off speed: **1300** to **1400 rpm**
- Injection pressure maximum value regulated by the rail pressure limiter

Test:

- Correct operation of sensor using the RENAULT TRUCKS diagnostics tool DIAGNOSTICA.
- Continuity of vehicle wiring harness between:
 - ECU connector terminal **A6** and sensor connector terminal **1**.
 - ECU connector terminal **A33** and sensor connector terminal **2**.
 - ECU connector terminal **A13** and sensor connector terminal **3**.
- Insulation of each wire.
- Sensor current supply (ECU connected, ignition switched on):
 - Presence of earth ($R < 10 \Omega$) at sensor connector terminal **1**.
 - Presence of + **5 Volts** at terminal **3** of the sensor connector.



Replace the rail pressure regulator without fail.

805 Sensors "+" 5 Volts current supply fault

Display message

- IMMEDIATE STOP

Major fault

Repercussion:

- No drop in engine power
- Operation of sensors in fall-back mode.
- Cut-off speed: **1300** to **1400 rpm**

Test:

- Presence of + **5 Volts** at the sensor terminals (ECU connected, ignition switched on):
 - Engine oil pressure sensor terminal **B**
 - Injection pressure sensor terminal **3**
 - Boost air pressure sensor terminal **3**
 - Terminal **1** of the cooling fan clutch
- Continuity of engine wiring harness between:
 - ECU connector terminal **A26** and engine oil pressure sensor connector terminal **B**
 - ECU connector terminal **A13** and injection pressure sensor connector terminal **3**
 - ECU connector terminal **A3** and boost air pressure sensor connector terminal **3**
- Insulation of each wire.

818 Exhaust brake electrovalve

Short-circuit to earth

Display message

- IMMEDIATE STOP

Major fault

Repercussion:

- Drop in engine power (120 seconds after the information)
- Exhaust brake strangler jammed in closed position

Test:

- Resistance of electrovalve winding (at **20°C**): **R = 43 → 49 Ω**
- Continuity of vehicle wiring harness between:
 - Terminal **B42** of the ECU connector and terminal **1** of the electrovalve.
 - Terminals **B22** and **B9** of the ECU connector and terminal **2** of the electrovalve.
- Electrovalve current supply (ECU connected, ignition switched on):
 - Presence of + **24 volts** at terminal **2** of the electrovalve connector
- Insulation of each wire.

819 → 820 Jake brake solenoid valves

819 Jake brake solenoid valve N° 1

820 Jake brake solenoid valve N° 2

Line short-circuit to + 24 Volts or to earth

Display message

- IMMEDIATE STOP

Major fault

Repercussion:

- Drop in engine power (120 seconds after the information)
- Retarder still activated or inoperative

Test:

- Resistance of solenoid valve winding (at **20°C**): **R = 32 → 40 Ω**
- Continuity of engine wiring harness between:

Solenoid valve N° 1

- Terminal **A8** of the ECU connector and wire **1007** connector on the solenoid valve.
- Terminal **A32** of the ECU connector and wire **2026** connector on the solenoid valve.
- Insulation of each wire (both solenoid valves disconnected)

Solenoid valve N° 2

- Terminal **A8** of the ECU connector and wire **1007** connector on the solenoid valve.
- Terminal **A27** of the ECU connector and wire **2027** connector on the solenoid valve.
- Insulation of each wire (both solenoid valves disconnected)

821 Starter

Short-circuit to earth

Display message

- IMMEDIATE STOP

Major fault

Repercussion:

- No drop in engine power
- Starter still engaged

Test:

- Continuity of vehicle wiring harness between:
 - Terminal **B11** of the ECU connector and wire **1077** connector on the relay.
 - Terminals **B9** and **B22** of the ECU connector and wire **292** connector on the relay.

824 Starting aids

Short-circuit to earth

Display message

- IMMEDIATE STOP

Major fault

- Preheating permanently activated

Repercussion:

- Drop in engine power (120 seconds after the information)

Test:

- Continuity of engine wiring harness between:
 - ECU connector terminal **B11** and relay **R93** terminal **2**.
 - ECU connector terminal **A39** and relay **R93** terminal **1**.
 - Relay **R93** terminal **3** and resistance.
 - Resistance and earth.
 - Relay **R93** terminal **5** and +

833 → 838 Fuel injectors

833 N° 1 cylinder fuel injector

834 N° 2 cylinder fuel injector

835 N° 3 cylinder fuel injector

836 N° 4 cylinder fuel injector

837 N° 5 cylinder fuel injector

838 N° 6 cylinder fuel injector

Short-circuit to earth

Display message

- IMMEDIATE STOP

Major fault

Repercussion:

- Operating failure of N° **1/2/3** cylinder injectors or N° **4/5/6** cylinder injectors
- About **50%** drop in engine power
- Injection pressure limited to **1000 bars**

Test:

- Insulation of wires (injector in question disconnected)

849 → 850 Fuel flow regulation solenoid valve

849 Fuel flow regulation solenoid valve N° 1

850 Fuel flow regulation solenoid valve N° 2

Line open-circuit or short-circuit to earth

Display message

- IMMEDIATE STOP

Major fault

Repercussion:

- No drop in engine power
- Cut-off speed: **1300 to 1400 rpm**
- Flow regulation ensured by non-defective solenoid valve
- High injection pressure (defective solenoid valve jammed in the open position)
- Injection pressure maximum value regulated by the rail pressure limiter



Replace the rail pressure regulator without fail.

Line short-circuit to +

Display message

- IMMEDIATE STOP

Major fault

Repercussion:

- No drop in engine power
- Cut-off speed: **1300 to 1400 rpm**
- Flow regulation ensured by non-defective solenoid valve
- High injection pressure (defective solenoid valve jammed in the closed position)

Test:

- Resistance of solenoid valve winding (at **20°C**): **R = 14 → 16 Ω**

Solenoid valve N° 1

- Continuity of engine wiring harness between:
 - ECU connector terminal **A9** and solenoid valve terminal **1**.
 - ECU connector terminal **A20** and solenoid valve terminal **2**.

Solenoid valve N° 2

- Continuity of engine wiring harness between:
 - ECU connector terminal **A7** and solenoid valve terminal **2**.
 - ECU connector terminal **A21** and solenoid valve terminal **1**.

851 Injection pressure outside operating band

Display message

- IMMEDIATE STOP

Major fault

Repercussion:

- No drop in engine power
- Cut-off speed: **1300** to **1400 rpm**
- Operation with a random rail pressure
- Injection pressure maximum value regulated by the rail pressure limiter

Test:

Fuel aspiration system.

- for leaks.
- for fouling (especially the prefilter).

Low pressure circuit.

- for leaks.
- correct operation of booster pump.
- for fouling (especially the filters).

High pressure circuit.

- for leaks.
- correct operation of high pressure pump.
- correct operation of fuel flow regulation solenoid valves.
- rail leak-off return circuit.
- correct operation of flow limiters.
- correct operation of fuel injectors.



Replace the rail pressure regulator without fail if the injection pressure is too high.

853 Battery charge voltage incorrect

9.6 V < Battery voltage > 34 V

Display message

- IMMEDIATE STOP

Major fault

Repercussion:

- No drop in engine power

Test:

- Correct operation of charging system
 - Charge voltage
 - Voltage regulator
 - Conformity, condition and connection of charging system
 - Condition and connection of batteries

854 Communication line between engine and vehicle ECUs (CAN BUS)

Display message

- IMMEDIATE STOP

Major fault

Repercussion:

- Engine speed permanently steady at **890 rpm**.

Test:

- Continuity of vehicle wiring harness between:
 - Terminal **B8** of the fuel-injection ECU and terminal **7** of the vehicle VECU connector (green wire).
 - Terminal **B39 6** of the vehicle VECU connector (red wire).
- Insulation of each wire.
- ECU current supply (vehicle ECU connected):
 - Presence of earth at injection ECU connector terminals **B12, B24, B43**.
 - Presence of after ignition + at terminals **B9, B22, B10, B41**.

856 Engine master ECU fault

Internal fault

Display message

- IMMEDIATE STOP

Major fault

Repercussion:

- Operating failure of N° **1/2/3** cylinder injectors or N° **4/5/6** cylinder injectors
- About **50%** drop in engine power

Test:

EECU box using the RENAULT TRUCKS diagnostics tool DIAGNOSTICA.

865 Accelerator pedal

Display message

- PEDAL FAULT.

Major fault

Repercussion:

- Engine speed permanently steady at **900 rpm**.

Test:

The test on the accelerator pedal should only be performed using the RENAULT TRUCKS diagnostic tool DIAGNOSTICA.

- Continuity of dashboard wiring harness between:
 - Terminal N° **1** of the black connector **18** and sensor connector terminal **5**.
 - Terminal N° **3** of the black connector **18** and sensor connector terminal **6**.
 - Terminal N° **4** of the black connector **18** and sensor connector terminal **1**.
 - Terminal N° **5** of the black connector **18** and sensor connector terminal **3**.

DIAGNOSTICS AID (SETTING +J01) VARIANT 14102

Diagnostic (dCi 11 +J01)

Instrument panel indicator lights

Indicator lights (1 - 2 - 3 - 4) inform the driver on the state of the system and on the kind of faults possibly detected or memorized. Warning light (1) indicates a major fault and requires the vehicle to be stopped immediately.

Warning light (2) indicates a minor fault.

Tell-tale light (3) indicates that the fault originates from a component managed by the engine master electronic control unit (EECU).

Tell-tale light (4) indicates that the fault originates from a component managed by the vehicle master electronic control unit (VECU).

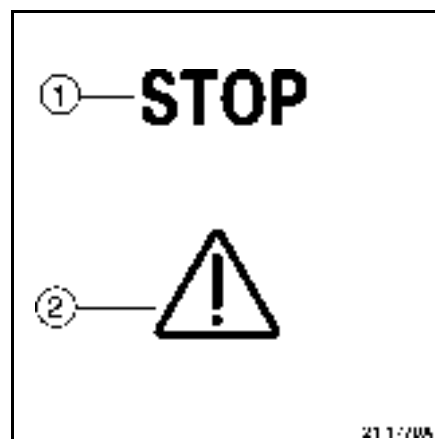

The system functions by virtue of default values that replace values that can no longer be measured. Certain functions may be inhibited or operate in fall-back mode.

In all cases, the fuel-injection system needs urgent maintenance.

In the case of detection of fault, engine performance may be impaired.

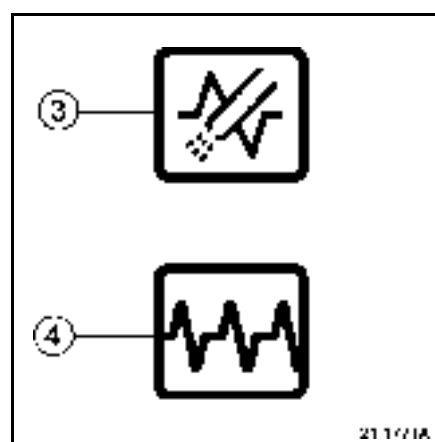

Faults can be visualized by using the RENAULT TRUCKS diagnostics tool DIAGNOSTICA plugged into the vehicle diagnostics socket (5) .

Faults can also be visualized on the instrument panel information display with the display of code numbers in the "present faults" or "memorized faults" sub-menus

After taking action, erase the fault code numbers using the RENAULT TRUCKS diagnostics tool DIAGNOSTICA.

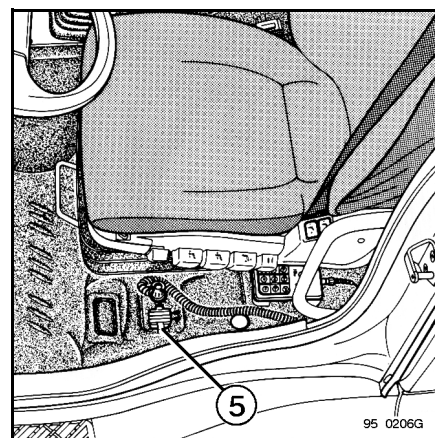

Use of the RENAULT TRUCKS diagnostic tool DIAGNOSTICA

The use of this tool provides great ease of diagnostics and its employment is strongly recommended. It is absolutely essential for erasing faults. Plug the diagnostics tool into the socket.

Available functions:

1/ Present faults

- component
- fault
- remedies

2/ Memorized faults

- component
- fault
- remedies
- erasure

3/ Diagnostic

- Diagnostics according to function
 - Exhaust brake
 - Declutching fan
 - Injection pressure
 - PTO
 - Warm-up
 - Exhaust brake strangler
- Visualization of inputs (digital displays and/or graphics of next values)
 - Engine operating time
 - Accelerator pedal position (%)
 - Battery voltage
 - Engine oil level
 - Coolant temperature
 - Boost air temperature
 - Atmospheric pressure
 - Engine oil pressure
 - Boost air pressure
 - Injection pressure
 - Engine speed
 - Vehicle road speed
 - Declutching fan speed
 - Injected fuel quantity
 - Injection timing
 - Exhaust brake presence
 - Jake brake presence
 - Exhaust brake pilot-control set-point
 - Air conditioning system in operation
 - Fast idling speed set-point (PTO)



The values for adjusting the accelerator pedal position are shown in the "VECU" menu.

Diagnostics using instrument panel display

Controls

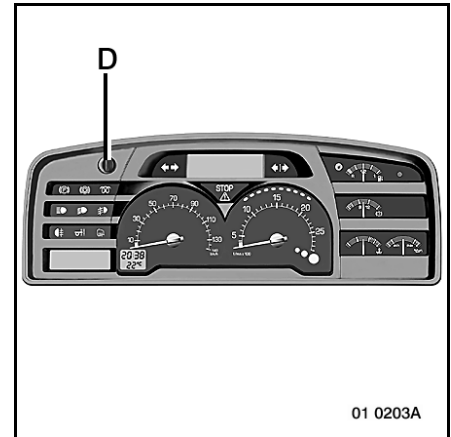

You are advised to use button (D) while the vehicle is stationary and correctly parked.

Button (D):

Push towards (+) or (-)

- to gain access to the different menus and sub-menus
- to make an adjustment or choice in the opened menu

Short pulses (V):

- open a selected menu.
- validate an adjustment or a choice in the menu selected
- scroll through present or memorized faults in succession

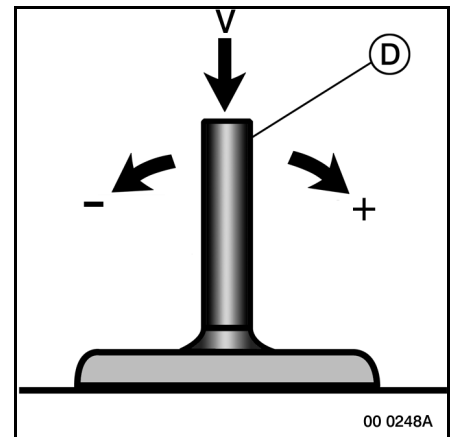

Button (AE):

Short pulses:

- serve to go back to the default display.
- close an opened menu without validating the adjustment or choice
- display the driver's various supplementary driving menus

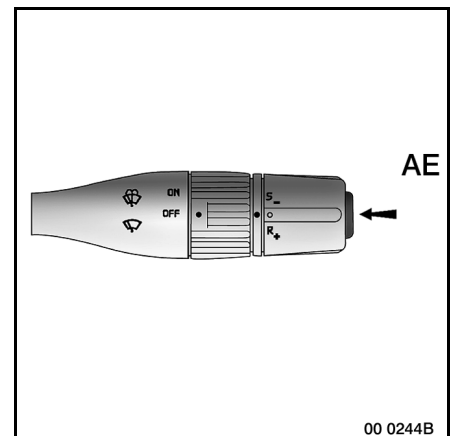

Meaning of fault codes

- **A:** fault number.
- **B:** fault type.
- **C:** number of appearances of fault.

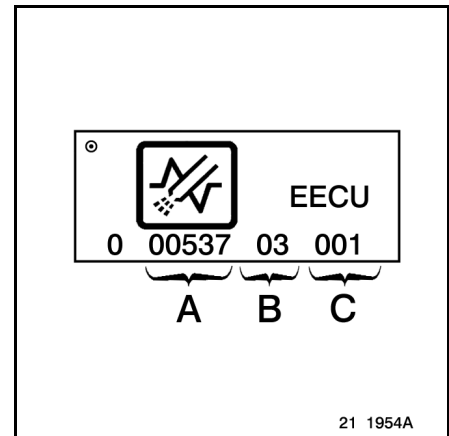
**Fault type (FMI).**

- 00: Data valid but above the normal operating band
- 01: Data valid but below the normal operating band
- 02: Data irregular, intermittent or incorrect
- 03: Voltage higher than rated voltage or short-circuit to +
- 04: Voltage higher than rated voltage or short-circuit to -
- 05: Amperage lower than normal or open-circuit
- 06: Amperage higher than normal or circuit to earth
- 07: Response from mechanical system incorrect
- 08: Frequency, pulse width or period abnormal
- 09: Refreshing speed abnormal
- 10: Variation rhythm abnormal
- 11: Failure mode non-identifiable
- 12: Smart peripheral or component defective
- 13: Outside calibration limits
- 14: Special instructions
- 15: Data valid but above the normal operating band (very low level of gravity)
- 16: Data valid but above the normal operating band (low level of gravity)
- 17: Data valid but below the normal operating band (very low level of gravity)
- 18: Data valid but below the normal operating band (low level of gravity)
- 19: Network data received illogical
- 31: Not available

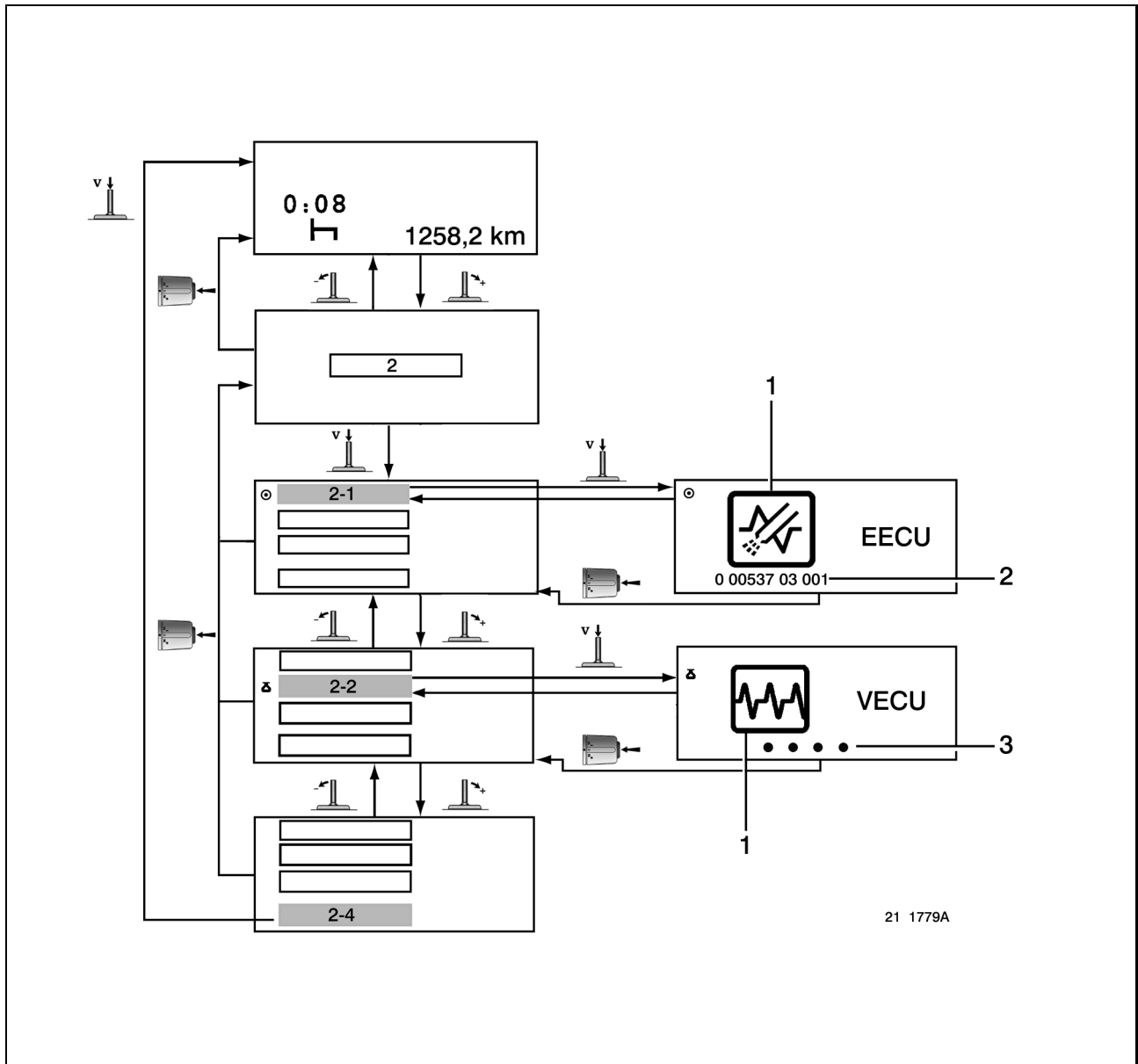

Select the diagnostics menu (2)

When the menu is open, the **STOP** warning light comes on.

Sub-menus

- **2-1**: Present faults
- **2-2**: Memorized faults
- **2-4**: Quit

In all cases, pictogram **(1)** indicates the function concerned. To obtain the desired function, use control **(D)** whenever necessary.

For "present faults" and "memorized faults" sub-menus, code number **(2)** characterizes the fault, or 4 dots **(3)** mean there are no faults.

List of fault code numbers



The repercussion of the fault code numbers listed hereafter is only significant in the event of one single fault being present. If there are several present faults, the impairment of the system features provided may be greater and lead to operating impossibility.

Only code numbers specific to fuel-injection are covered in this document.

Faults relative to other functions may impair the features provided by the fuel-injection system (refer to the workshop manual sections corresponding to the systems incriminated).

To perform more comprehensive diagnostics on vehicle wiring harness runs, refer to the "PREMIUM Electrics" or "KERAX Electrics" workshop manual section for the vehicle.

Recap table of fault code numbers

Fault code	Nature of incident	See page
16	Fuel filters clogging sensor	M-10
91	Accelerator pedal	M-10
94	Fuel high pressure sensor	M-10
95	Clogged fuel filters	M-11
98	Engine oil level sensor	M-11
100	Engine oil pressure sensor	M-11
102	Boost air pressure sensor	M-12
105	Boost air temperature sensor	M-12
110	Engine cooling circuit temperature sensor	M-12
164	Injection pressure outside normal operating band	M-13
168	Battery charge voltage incorrect	M-13
190	Flywheel speed sensor	M-14
558	Accelerator pedal	M-10
597	Cruise-control switch	M-14
598	Cruise-control switch	M-14
601	Cruise-control switch	M-14
604	Cruise-control switch	M-14
611	Engine ECU fault	
628	Parameter definition	M-15
629	Engine ECU fault	
630	Parameter definition	M-15
631	Engine ECU fault	
636	High pressure pump speed sensor	M-15
647	Declutching fan speed regulation solenoid valve	M-16
651	N° 1 cylinder fuel injector 1	M-17
652	N° 1 cylinder fuel injector 2	M-17

Fault code	Nature of incident	See page
653	N° 1 cylinder fuel injector 3	M-17
654	N° 1 cylinder fuel injector 4	M-17
655	N° 1 cylinder fuel injector 5	M-17
656	N° 1 cylinder fuel injector 6	M-17
676	Starting devices	M-18
677	Starter	M-18
970	Engine ECU fault	
1072	Jake brake solenoid valve N°1	M-19
1073	Jake brake solenoid valve N°2	M-19
1074	Exhaust brake electrovalve	M-20
1079	Sensors "+" 5 Volts current supply fault	
1231	Communication line between engine and vehicle ECUs (CAN bus)	
1267	Engine stop control (cab tilted)	M-21
1347	Fuel flow regulation solenoid valve N°1	M-22
1348	Fuel flow regulation solenoid valve N°2	M-22
1479	Engine ECU fault	M-23
1639	Declutching fan speed sensor	M-23

Assignment of pins to ECU wiring harness connector

(Connector face view)

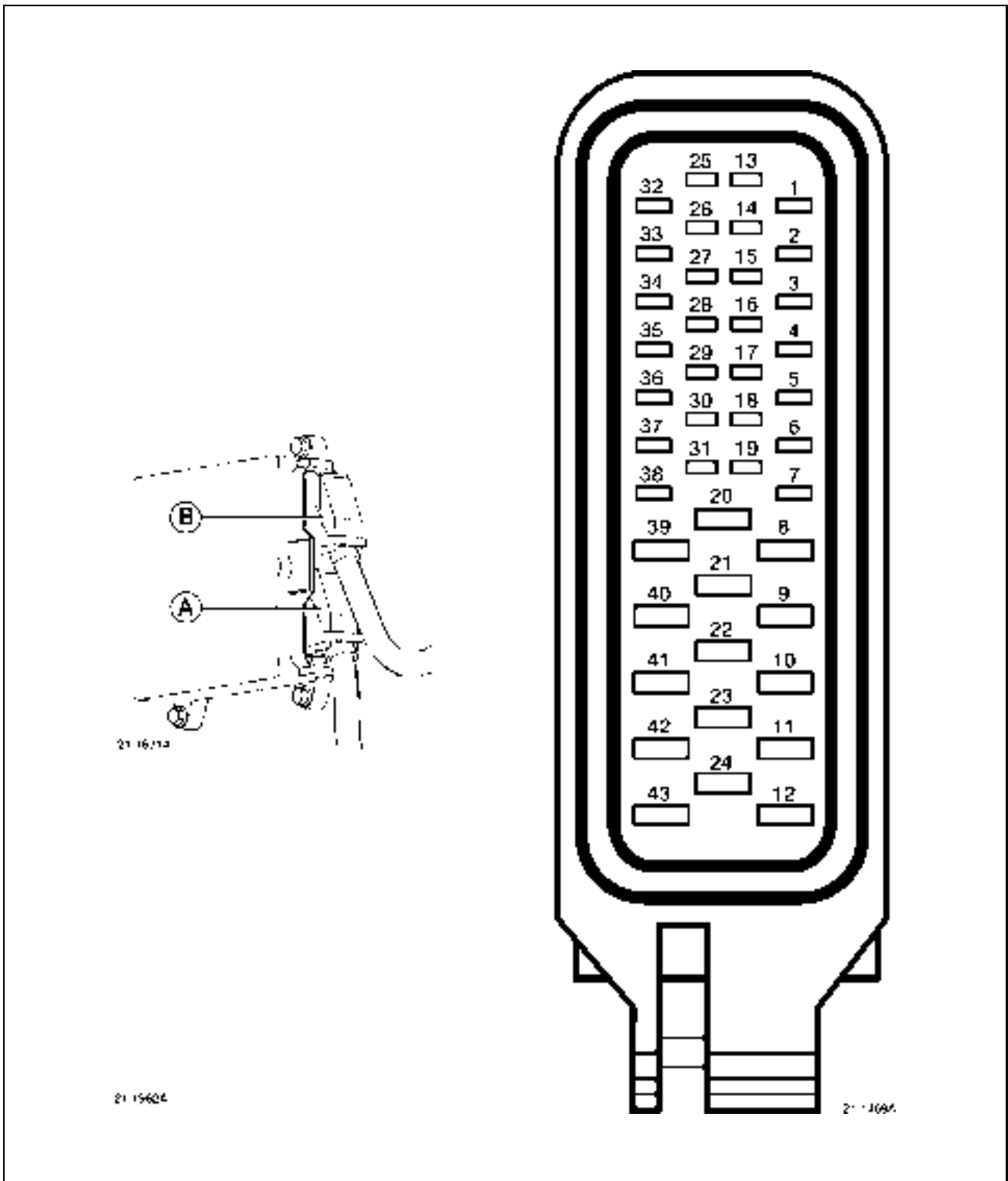

16 Fuel filters clogging sensor

Display message

- WORKSHOP STOP.

Minor fault

Repercussion:

- No drop in engine power

Test:

- Correct operation of switch:
 - Switch contacts open in the rest position.
 - Switch contacts open when **P1 ≥ 3 bars P2**.
 - Button returns to rest position under effect of return spring.
- Switch current supply (ECU connected, ignition switched on):
 - Presence of + **24 Volts** at one of the switch connector terminals (wire **292**).
- Continuity of vehicle wiring harness between:
 - **EECU** connector terminal **B33** and one of the sensor terminals (wire **8072**).
 - **EECU B9, B22 B32** and one of the sensor terminals (wire **292**).
- Insulation of each wire.

91 / 558 Accelerator pedal

Display message

- PEDAL FAULT.

Major fault

Repercussion:

- Engine speed permanently steady at **900 rpm**.

Test:

The test on the accelerator pedal should only be performed using the RENAULT TRUCKS test tool DIAGNOSTICA.

- Continuity of dashboard wiring harness between:
 - Terminal N° **1** of the black connector **18** and sensor connector terminal **5**.
 - Terminal N° **3** of the black connector **18** and sensor connector terminal **6**.
 - Terminal N° **4** of the black connector **18** and sensor connector terminal **1**.
 - Terminal N° **5** of the black connector **18** and sensor connector terminal **3**.

94 High pressure fuel sensor

Display message

- IMMEDIATE STOP

Major fault

Repercussion:

- No drop in engine power
- Default pressure mapping (**1500 bars**)
- Cut-off speed: **1300** to **1400 rpm**
- Injection pressure maximum value regulated by the rail pressure limiter

Test:

- Operation of the sensor should only be tested using the RENAULT TRUCKS diagnostic tool DIAGNOSTICA.
- Continuity of vehicle wiring harness between:
 - ECU connector terminal **A6** and sensor connector terminal **1**.
 - ECU connector terminal **A33** and sensor connector terminal **2**.
 - ECU connector terminal **A13** and sensor connector terminal **3**.
- Insulation of each wire.
- Sensor current supply (ECU connected, ignition switched on):
 - Presence of earth ($R < 10 \Omega$) at sensor connector terminal **1**.
 - Presence of + **5 Volts** at terminal **3** of the sensor connector.



Replace the rail pressure regulator without fail.

95 Clogged fuel filters

Display message

- CLOGGED FUEL FILTERS

Minor fault

- No drop in engine power
- Cut-off speed **1300 to 1400 rpm.**

Test:

- Replace the fuel filters

98 Engine oil level sensor

Display message

- SENSOR FAULT.

Minor fault

Repercussion:

- No drop in engine power
- Default value: engine oil circuit empty

Test:

- Resistance of sensor (see "Technical data" chapter for the values)
- Continuity of engine wiring harness between:
 - ECU connector terminal **A17** and sensor connector terminal **2**.
 - ECU connector terminal **A38** and sensor connector terminal **1**.
- Insulation of each wire.

100 Engine oil pressure sensor

Display message

- URGENT REPAIR

Minor fault

Repercussion:

- No drop in engine power
- Default value: oil pressure = **6 bars.**

Test:

- Operation of the sensor should only be tested using the RENAULT TRUCKS diagnostic tool DIAGNOSTICA.
- Continuity of engine wiring harness between:
 - ECU connector terminal **A5** and sensor connector terminal **C**.
 - ECU connector terminal **A18** and sensor connector terminal **A**.
 - ECU connector terminal **A26** and sensor connector terminal **B**.
- Insulation of each wire.
- Sensor current supply (ECU connected, ignition switched on):
 - Presence of + **5 Volts** at terminal **B** of the sensor connector.
 - Presence of earth ($R < 10 \Omega$) at sensor connector terminal **A**.

102 Boost air pressure sensor

Display message

- POWER LOSS

Minor fault

Repercussion:

- Protection mode (low output)
- Default value: boost air pressure = **1013 mbar(s)**.
- Default value: atmospheric air pressure = **0 mbar(s)**.

Test:

- Resistance at sensor terminals (at **20 °C**) between:
 - Between terminals **3** and **4**: R = **3400 → 8200 Ω**.
 - Between terminals **3** and **1**: R = **2400 → 8200 Ω**.
- Continuity of engine wiring harness between:
 - ECU connector terminal **A19** and sensor connector terminal **1**.
 - ECU connector terminal **A3** and sensor connector terminal **3**.
 - ECU connector terminal **A34** and sensor connector terminal **4**.
- Insulation of each wire.
- Switch current supply (ECU connected, ignition switched on):
 - Presence of **+ 5 Volts** at terminal **3** of the sensor connector.
 - Presence of earth (R < **10 Ω**) at sensor connector terminal **1**.

105 Boost air temperature sensor

Display message

- POWER LOSS

Minor fault

Repercussion:

- Protection mode.
- Default value: boost air temperature = **60°C**

Test:

- Resistance of sensor (see "Technical data" chapter for the values)
- Continuity of engine wiring harness between:
 - ECU connector terminal **A19** and sensor connector terminal **1**.
 - ECU connector terminal **A2** and sensor connector terminal **2**.
- Insulation of each wire.
- Switch current supply (ECU connected, ignition switched on):
 - Presence of earth (R < **10 Ω**) at sensor connector terminal **1**.
 - Presence of **+ 5 Volts** at terminal **2** of the sensor connector.

110 Engine cooling circuit temperature sensor

Display message

- URGENT REPAIR

Minor fault

Repercussion:

- Protection mode.
- Default value: coolant temperature = **98 °C**.

Test:

- Resistance of sensor (see "Technical data" chapter for the values)
- Continuity of engine wiring harness between:
 - ECU connector terminal **A30** and sensor connector terminal **2**.
 - ECU connector terminal **A1** and sensor connector terminal **1**.
- Insulation of each wire.
- Sensor current supply (ECU connected, ignition switched on):
 - Presence of **+ 5 Volts** at sensor connector terminal **1**.
 - Presence of earth (R < **10 Ω**) at sensor connector terminal **2**.

164 Injection pressure outside operating band

Display message

- IMMEDIATE STOP

Major fault

Repercussion:

- No drop in engine power
- Cut-off speed: **1300 to 1400 rpm**
- Operation with a random rail pressure
- Injection pressure maximum value regulated by the rail pressure limiter

Test:

Fuel aspiration system.

- for leaks.
- for fouling (especially the prefilter).

Low pressure circuit.

- for leaks.
- correct operation of booster pump.
- for fouling (especially the filters).

High pressure circuit.

- for leaks.
- correct operation of high pressure pump.
- correct operation of fuel flow regulation solenoid valves.
- rail leak-off return circuit.
- correct operation of flow limiters.
- correct operation of fuel injectors.



Replace the rail pressure regulator without fail if the injection pressure is too high.

168 Battery charge voltage incorrect

9.6 V < Battery voltage > 18.5 V

31 V < Battery voltage > 34 V

Display message

- VOLTAGE FAULT

Minor fault

Battery voltage < 9.6 V

Battery voltage > 34 V

Display message

- VOLTAGE FAULT

Major fault

Repercussion:

- No drop in engine power

Test:

- Correct operation of charging system
 - Charge voltage
 - Voltage regulator
 - Conformity, condition and connection of charging system
 - Condition and connection of batteries

190 Flywheel speed sensor

Display message

- URGENT REPAIR

Minor fault

Repercussion:

- Drop in engine power (120 seconds after the information)
- Engine operation impaired if there is reversal of polarity
- Longer starting time (about 6 seconds)
- Operation on pump speed sensor

Test:

- Resistance at sensor terminals (at 20°C): $R = 770 \rightarrow 950 \Omega$
- Insulation of each wire.
- Continuity of vehicle wiring harness between:
 - ECU connector terminal **A29** and sensor connector terminal **1**.
 - ECU connector terminal **A37** and sensor connector terminal **2**.

597 / 598 / 601 / 604 Cruise control

Display message

- CRUISE CONTROL INOPERATIVE

Minor fault

Repercussion:

- Operating failure of cruise control, idling speed adjustment and fast idling functions

Test:

- Correct operation of cruise control:
 - Control switch in position "**ON**", contact closed between terminals **B5** and **B6**
 - Control switch in position "**OFF**", contact open between terminals **B5** and **B6**
 - Control switch in position "**R/+**", contact closed between terminals **B7** and **B2**
 - Control switch in position "**S/-**", contact closed between terminals **B1** and **B2**
 - Control switch in position "**O**", contact open between terminals **B1** and **B2** and terminals **B7** and **B2**
- Continuity of wiring harness
- The control connector is the one connected directly to the cruise control
- Continuity of dashboard wiring harness between:
 - VECU **18**-way black connector terminal **6** and control connector terminal **B5**.
 - VECU **18**-way black connector terminal **7** and control connector terminal **B1**.
 - VECU **18**-way black connector terminal **8** and control connector terminal **B7**.
- Control current supply
 - Presence of earth at control connector terminal **B2**.
 - Presence of + **24 Volts** at terminals **B1**, **B5** and **B7** of the control switch connector.

611 Engine master ECU fault

Internal fault

Display message

- IMMEDIATE STOP

Major fault

Repercussion:

- Operating failure of N° **1/2/3** cylinder injectors or N° **4/5/6** cylinder injectors
- About **50%** drop in engine power

Test:

Test **EECU** box using the RENAULT TRUCKS test tool DIAGNOSTICA

628 / 630 Parameter definition

Display message

- PARAMETER DEFINITION

Minor fault

- Parameters of ECU supplied by BOSCH not redefined by RENAULT TRUCKS.

Repercussion:

- No drop in engine power

Remedy:

- Define the EECU parameters.

629 / 631 / 970 Engine master ECU fault

Memory fault or fault memorizing procedure fault

Display message

- ENGINE FAULT

Minor fault

Repercussion:

- No drop in engine power
- No memorizing of faults

Engine / pump speed sensor acquisition interface fault

Display message

- ENGINE FAULT

Minor fault

Repercussion:

- Drop in engine power (120 seconds after the information)
- Erratic operation of the engine

Test:

Test **EECU** box using the RENAULT TRUCKS test tool DIAGNOSTICA

636 High pressure pump speed sensor

Display message

- URGENT REPAIR

Minor fault

Repercussion:

- No drop in engine power
- Longer starting time (about 6 seconds)
- Operation of engine speed sensor on flywheel

Test:

- Resistance at sensor terminals (at 20°C): $R = 770 \rightarrow 950 \Omega$
- Insulation of each wire.
- Continuity of vehicle wiring harness between:
 - ECU connector terminal **A4** and sensor connector terminal **2**.
 - ECU connector terminal **A31** and sensor connector terminal **1**.

647 Declutching fan speed regulation solenoid valve

Line open-circuit or short-circuit to + 24 Volts

Display message

- COOLING FAN INOPERATIVE

Minor fault

Repercussion:

- No drop in engine power
- Cooling fan driven at maximum speed

Line short-circuit to earth

Display message

- COOLING FAN INOPERATIVE

Minor fault

Repercussion:

- No drop in engine power
- Cooling fan driven at maximum speed

Test:

- Solenoid valve resistance between terminals **4** and **5** of the fan clutch connector (at **20°C**): $R = 55 \rightarrow 65 \Omega$
- Continuity of vehicle wiring harness between:
 - Terminal **B23** of the ECU connector and terminal **4** of the fan clutch connector.
 - Terminals **B22** and **B9** of the ECU connector and terminal **5** of the fan clutch connector.
- Solenoid valve current supply (ECU connected, ignition switched on):
 - Presence of + **24 Volts** at terminal **5** of the fan clutch connector.
- Insulation of each wire.

651 → 656 Fuel injectors

651 N° 1 cylinder fuel injector

652 N° 2 cylinder fuel injector

653 N° 3 cylinder fuel injector

654 N° 4 cylinder fuel injector

655 N° 5 cylinder fuel injector

656 N° 6 cylinder fuel injector

Electrical system open-circuit

Display message

- INJECTOR FAULT

Minor fault

Repercussion:

- Operating failure of fuel injector in question
- Injection pressure limited to **1000 bars**

Test:

Resistance of fuel injector solenoid valve winding (at 20°C): **R = 0.3 → 0.5 Ω**

- Continuity of engine wiring harness between:
 - Terminals **A40** and **A41** of the ECU connector and wire **173** at the terminals of fuel injectors N° **1/2/3**
 - Terminals **A42** and **A43** of the ECU connector and wire **173** at the terminals of fuel injectors N° **4/5/6**
 - ECU connector terminal **A12** and N° **1** injector terminal wire **293**.
 - ECU connector terminal **A11** and N° **2** injector terminal wire **295**.
 - ECU connector terminal **A24** and N° **3** injector terminal wire **294**.
 - ECU connector terminal **A22** and N° **4** injector terminal wire **298**.
 - ECU connector terminal **A23** and N° **5** injector terminal wire **296**.
 - ECU connector terminal **A10** and N° **6** injector terminal wire **297**.

Short-circuit to earth

Display message

- INJECTOR FAULT

Major fault

Repercussion:

- Operating failure of N° **1/2/3** cylinder injectors or N° **4/5/6** cylinder injectors
- About **50%** drop in engine power
- Injection pressure limited to **1000 bars**

Test:

- Insulation of wires (injector in question disconnected)

676 Starting aids

Open-circuit or short-circuit to + 24 Volts current supply

Display message

- SWITCH OFF THE IGNITION

Major fault

- No air preheating

Repercussion:

- Drop in engine power (120 seconds after the information)

Test:

- Continuity of engine wiring harness between:
 - ECU connector terminal **B11** and relay **R93** terminal **2**.
 - ECU connector terminal **A39** and relay **R93** terminal **1**.
 - Relay **R93** terminal **3** and resistance.
 - Resistance and earth.
 - Relay **R93** terminal **5** and +
- Insulation of each wire.

Short-circuit to earth

Display message

- SWITCH OFF THE IGNITION

Major fault

- Preheating permanently activated

Repercussion:

- Drop in engine power (120 seconds after the information)

Test:

- Continuity of engine wiring harness between:
 - ECU connector terminal **B11** and relay **R93** terminal **2**.
 - ECU connector terminal **A39** and relay **R93** terminal **1**.
 - Relay **R93** terminal **3** and resistance.
 - Resistance and earth.
 - Relay **R93** terminal **5** and +

677 Starter

Line short-circuit to + 24 Volts

Display message

- STARTER INOPERATIVE

Minor fault

- No drop in engine power
- No engine starting

Test:

- Continuity of vehicle wiring harness between:
 - Terminal **B11** of the ECU connector and wire **1077** connector on the relay.
 - Terminals **B9** and **B22** of the ECU connector and wire **292** connector on the relay.

Line open-circuit or short-circuit to earth

Display message

- STARTER INOPERATIVE

Major fault

Repercussion:

- No drop in engine power
- Starter still engaged

Test:

- Continuity of vehicle wiring harness between:
 - Terminal **B11** of the ECU connector and wire **1077** connector on the relay.
 - Terminals **B9** and **B22** of the ECU connector and wire **292** connector on the relay.

1072 → 1073 Jake brake solenoid valves

1072 Jake brake solenoid valve N° 1

1073 Jake brake solenoid valve N° 2

Line open-circuit or short-circuit to + 24 Volts

Display message

- ENGINE BRAKE INOPERATIVE

Minor fault

Repercussion:

- Drop in engine power (120 seconds after the information)
- Operating failure of the retarder function

Test:

- Resistance of solenoid valve winding (at 20°C): $R = 32 \rightarrow 40 \Omega$
- Continuity of engine wiring harness between:

Solenoid valve N° 1

- Terminal **A8** of the ECU connector and wire **1007** connector on the solenoid valve.
- Terminal **A32** of the ECU connector and wire **2026** connector on the solenoid valve.
- Insulation of each wire (both solenoid valves disconnected)

Solenoid valve N° 2

- Terminal **A8** of the ECU connector and wire **1007** connector on the solenoid valve.
- Terminal **A27** of the ECU connector and wire **2027** connector on the solenoid valve.
- Insulation of each wire (both solenoid valves disconnected)

Short-circuit to earth

Display message

- ENGINE BRAKE INOPERATIVE

Major fault

Repercussion:

- Drop in engine power (120 seconds after the information)
- Operating failure of the retarder function

Test:

- Resistance of solenoid valve winding (at 20°C): $R = 32 \rightarrow 40 \Omega$
- Continuity of engine wiring harness between:

Solenoid valve N° 1

- Terminal **A8** of the ECU connector and wire **1007** connector on the solenoid valve.
- Terminal **A32** of the ECU connector and wire **2026** connector on the solenoid valve.
- Insulation of each wire (both solenoid valves disconnected)

Solenoid valve N° 2

- Terminal **A8** of the ECU connector and wire **1007** connector on the solenoid valve.
- Terminal **A27** of the ECU connector and wire **2027** connector on the solenoid valve.
- Insulation of each wire (both solenoid valves disconnected)

1074 Exhaust brake solenoid valve

Open-circuit or short-circuit to + 24 Volts current supply

Display message

- ENGINE BRAKE INOPERATIVE

Minor fault

Repercussion:

- Drop in engine power (120 seconds after the information)
- Operating failure of the exhaust brake function

Test:

- Resistance of solenoid valve winding (at 20°C): $R = 43 \rightarrow 49 \Omega$
- Continuity of vehicle wiring harness between:
 - ECU connector terminal **A42** and electrovalve terminal **1**.
 - ECU connector terminal **B22**, **B9** and electrovalve terminal **2**.
- Electrovalve current supply (ECU connected, ignition switched on):
 - Presence of + **24 volts** at terminal **2** of the electrovalve connector
- Insulation of each wire.

Short-circuit to earth

Display message

- ENGINE BRAKE INOPERATIVE

Major fault

Repercussion:

- Drop in engine power (120 seconds after the information)
- Exhaust brake strangler jammed in closed position

Test:

- Resistance of electrovalve winding (at 20°C): $R = 43 \rightarrow 49 \Omega$
- Continuity of vehicle wiring harness between:
 - ECU connector terminal **B42** and electrovalve terminal **1**.
 - ECU connector terminal **B22**, **B9** and electrovalve terminal **2**.
- Electrovalve current supply (ECU connected, ignition switched on):
 - Presence of + **24 volts** at terminal **2** of the electrovalve connector
- Insulation of each wire.

1079 Sensors "+" 5 Volts current supply fault

Display message

- IMMEDIATE STOP

Major fault

Repercussion:

- No drop in engine power
- Operation of sensors in fall-back mode.
- Cut-off speed: **1300** to **1400 rpm**

Test:

- Presence of + **5 Volts** at the sensor terminals (ECU connected, ignition switched on):
 - Engine oil pressure sensor terminal **B**
 - Injection pressure sensor terminal **3**
 - Boost air pressure sensor terminal **3**
- Continuity of engine wiring harness between:
 - ECU connector terminal **A26** and engine oil pressure sensor connector terminal **B**
 - ECU connector terminal **A13** and injection pressure sensor connector terminal **3**
 - ECU connector terminal **A3** and boost air pressure sensor connector terminal **3**
- Insulation of each wire.

1231 Communication line between engine and vehicle ECUs (CAN BUS)

Display message

- URGENT REPAIR

Major fault

Repercussion:

- Engine speed permanently steady at **890 rpm**.

Test:

- Continuity of vehicle wiring harness between:
 - Terminal **B8** of the fuel-injection ECU and terminal **7** of the vehicle VECU connector (green wire).
 - Terminal **B39 6** of the vehicle VECU connector (red wire).
- Insulation of each wire.
- ECU current supply (vehicle ECU connected):
 - Presence of earth at injection ECU connector terminals **B12, B24, B43**.
 - Presence of after ignition + at terminals **B9, B22, B10, B41**.

1267 Engine stop control (cab tilted)

Display message

- WORKSHOP STOP.

Minor fault

Repercussion:

- No drop in engine power
- Operating failure of the engine stop function with the switch

Test:

- Correct operation of switch:
 - Switch contacts open in the rest position.
 - Switch contacts closed when the button is depressed
 - Button returns to rest position under effect of return spring.
- Switch current supply (ECU connected, ignition switched on):
 - Presence of **24 Volts** at one of the switch connector terminals.
- Continuity of vehicle wiring harness between:
 - ECU connector terminal **B32** and switch terminal **2**.
 - ECU connector terminal **B22 B9** and switch terminal **1**.
- Insulation of each wire.

1347 → 1348 Fuel flow regulation solenoid valve

1347 Fuel flow regulation solenoid valve N° 1

1348 Fuel flow regulation solenoid valve N° 2

Line open-circuit or short-circuit to earth

Display message

- IMMEDIATE STOP

Major fault

Repercussion:

- No drop in engine power
- Cut-off speed: **1300 to 1400 rpm**
- Flow regulation ensured by non-defective solenoid valve
- High injection pressure (defective solenoid valve jammed in the open position)
- Injection pressure maximum value regulated by the rail pressure limiter



Replace the rail pressure regulator without fail.

Line short-circuit to +

Display message

- IMMEDIATE STOP

Major fault

Repercussion:

- No drop in engine power
- Cut-off speed: **1300 to 1400 rpm**
- Flow regulation ensured by non-defective solenoid valve
- High injection pressure (defective solenoid valve jammed in the closed position)

Test:

- Resistance of solenoid valve winding (at **20°C**): **R = 14 → 16 Ω**

Solenoid valve N° 1

- Continuity of engine wiring harness between:
 - ECU connector terminal **A9** and solenoid valve terminal **1**.
 - ECU connector terminal **A20** and solenoid valve terminal **2**.

Solenoid valve N° 2

- Continuity of engine wiring harness between:
 - ECU connector terminal **A7** and solenoid valve terminal **2**.
 - ECU connector terminal **A21** and solenoid valve terminal **1**.

1479 Engine master ECU fault

Memory fault or fault memorizing procedure fault

Display message

- IMMEDIATE STOP

Major fault

Repercussion:

- No drop in engine power
- No memorizing of faults

Engine / pump speed sensor acquisition interface fault

Display message

- IMMEDIATE STOP

Major fault

Repercussion:

- Drop in engine power (120 seconds after the information)
- Erratic operation of the engine

Test:

Test **EECU** box using the RENAULT TRUCKS test tool DIAGNOSTICA

1639 Declutching fan speed sensor

Display message

- SENSOR FAULT.

Minor fault

Repercussion:

- No drop in engine power
- Cooling fan driven at maximum speed
- Cut-off speed **1300** to **1400 rpm**.

Test:

- Continuity of vehicle wiring harness between:
 - Terminal **B34** of the ECU connector and terminal **1** of the fan clutch connector.
 - Terminal **B14** of the ECU connector and terminal **2** of the fan clutch connector.
 - Terminal **B4** of the ECU connector and terminal **3** of the fan clutch connector.
- Insulation of each wire.
- Sensor current supply (ECU connected, ignition switched on):
 - Presence of earth at terminal **1** of the sensor connector.
 - Presence of + **5 Volts** at terminal **2** of the sensor connector.

TURBOCHARGER

Operating trouble

Each turbocharged engine possesses its own characteristic sound. Owing to this, many defects can be detected merely by noticing a change in the customary noise signature.

If the sound level becomes sharper, it may be due to leaking charge air (between turbocharger and intake manifold) or exhaust gas, or a drive shaft defect.

An intermittent change in noise level may be due to turbocharger fouling or use of the engine at underspeed in relation to load.

The appearance of vibration may indicate a drive shaft defect.

A sudden reduction in noise, accompanied by the appearance of black or blue exhaust smoke is the sign of total break-up of the turbocharger.

In all cases, immediately stop the engine to avoid more serious damage to the turbocharger and to the engine.

On-vehicle checks

Engine stopped:

Refer to technical document "DT 357".

Engine idling:

Check the air pipes between air filter and turbocharger for leaks by spraying Start Pilote fluid. Leakage will be indicated by an increase in engine speed.

Engine running at 1 200 rpm.:

Check for leaks between turbocharger and engine using a leak detector. Check for exhaust gas leaks (actuate the exhaust brake). Replace gaskets, if necessary. A gas leak can be detected by a change in colour at the place of the leak.

Removal / fitting of turbocharger

These operations do not present any difficulty. Clean all the air conduits and make sure there is no foreign matter left. Before tightening the exhaust manifold setscrews, smear the screw-threads with high temperature-resistant grease (Renault Trucks Oils Gripcott NF grease) or equivalent.

Tighten to torque (see page B-2-5).



Any turbocharger replacement, where the cause of damage has not been defined, may lead to new incidents and serious engine damage.

Do not use jointing compound on the turbocharger lubrication pipe fastening flanges. Before installing the turbocharger, pour fresh oil through the oil inlet port and turn the rotor by hand to lubricate the journals and the thrust bearing.

After installing the turbocharger, run the engine and wait for 30 seconds before accelerating.

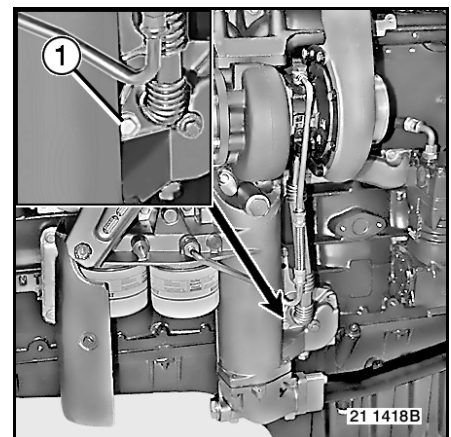

UPON ASSEMBLY, IT IS VITAL TO ENSURE THE LENGTH UNDER THE HEAD OF SCREW (1) WHICH MUST BE EQUAL TO 60 MM.

ENSURE A TIGHT SEAL WITH A SEALING PRODUCT FRENETANCH 242.

Incidents and probable causes



Before implicating the turbocharger, ensure that the engine and its surrounds are in perfect condition.

Lack of engine power

- Air filter clogged
- Aftercooler air/air heat exchanger (tube stack fouled)
- Aspiration air manifold blockage or crushing (between air filter and turbocharger)
- Boost air manifold blockage or crushing (between turbocharger and engine)
- Foreign matter between air filter and turbocharger
- Exhaust blockage or crushing
- Air or gas leak between turbocharger and engine
- Turbine housing damaged or fouled
- Turbo impeller vanes damaged
- Turbocharger pressure regulation system (wastegate) malfunction*

Black exhaust smoke

- Air filter clogged
- Aspiration air manifold blockage or crushing (between air filter and turbocharger)
- Boost air manifold blockage or crushing (between turbocharger and engine)
- Air or gas leak between turbocharger and engine
- Turbocharger damaged or fouled
- Turbocharger pressure regulation system (wastegate) malfunction*

Blue exhaust smoke

- Engine breather clogged
- Oil consumption
- Oil return pipe clogged or crushed
- Turbocharger damaged or fouled
- Prolonged running at idling speed
- Air compressor defective

Strange noise

- Air filter clogged
- Air filter / turbocharger link leakage
- Aspiration air manifold blockage or crushing (between air filter and turbocharger)
- Boost air manifold blockage or crushing (between turbocharger and engine)
- Foreign matter between air filter and turbocharger
- Exhaust blockage or crushing
- Air or gas leak between turbocharger and engine
- Turbocharger lubrication defect
- Turbocharger damaged or fouled
- Engine used at underspeed in relation to load
- Turbocharger pressure regulation system (wastegate) malfunction*

Incidents and probable causes (cont.)

Excessive oil consumption

- Air filter clogged
- Engine breather clogged
- Aspiration air manifold blockage or crushing (between air filter and turbocharger)
- Turbocharger lubrication defect
- Oil return pipe clogged or crushed
- Turbocharger damaged or fouled
- Prolonged running at idling speed
- Air compressor defective

Oil in air pipes before turbocharger

- Air filter clogged
- Aspiration air manifold blockage or crushing (between air filter and turbocharger)
- Air compressor defective

Oil in air pipes after turbocharger

- Air filter clogged
- Engine breather clogged
- Aspiration air manifold blockage or crushing (between air filter and turbocharger)
- Oil return pipe clogged or crushed
- Turbocharger damaged or fouled
- Prolonged running at idling speed

Oil in exhaust manifold

- Prolonged running at idling speed

Oil in exhaust pipes after turbocharger

- Engine breather clogged
- Oil return pipe clogged or crushed
- Turbocharger damaged or fouled
- Prolonged running at idling speed

JAKE BRAKE

Exploded view

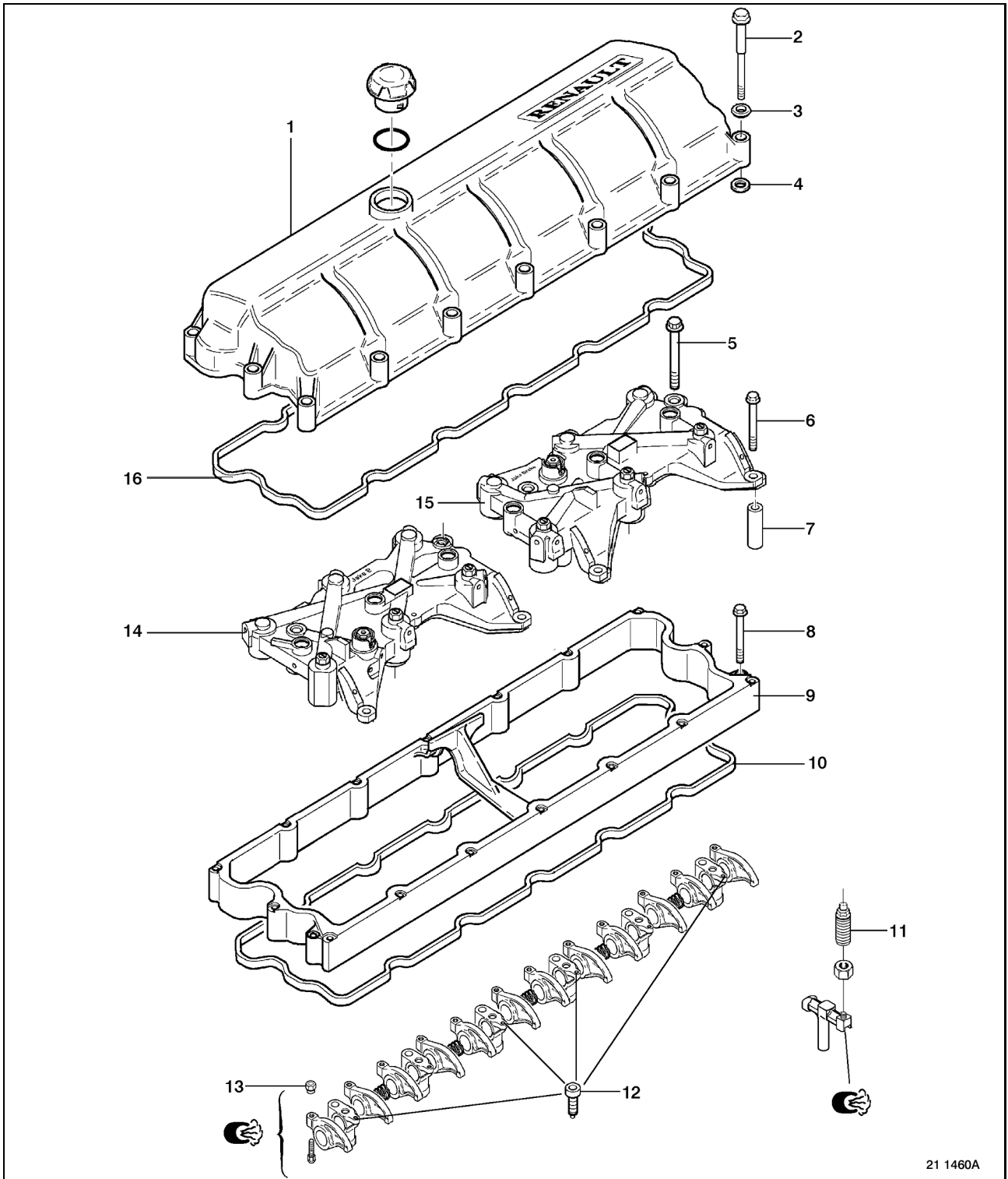

21 1460A

Removal

The item numbers indicated in the text refer to the drawing on page O-2.

- Remove the cylinder head cover (1).
- Take out gasket (16).
- Disconnect wires (A).
- Withdraw the wiring harness from clips (B).
- Tighten nuts (C).
- Move aside the wiring harness complete with bracket (D).
- Tighten nuts (5 - 6).
- Remove mechanisms (14 - 15).
- Save spacers (7).
- Tighten nuts (8).
- Disconnect the wiring harness from the injectors.
- Withdraw spacer (9).
- Take out gasket (10).

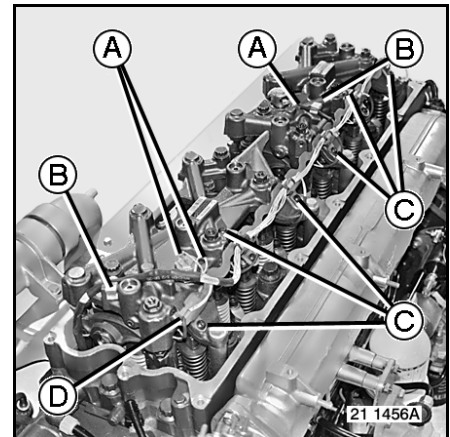

Inspection

- Check for the presence of spherical nuts (13) on the exhaust rocker arms.
- Test for the presence and free sliding of control plungers (11) on the exhaust valve yokes.
- Check for the presence of mechanism positioning screws (12) on the rocker shaft pedestals.
- Check the adjustment of the valve yokes.



If the valve yokes have to be adjusted, so will the valve rocker clearances.

See page E-2-1

Fitting

- Install seal (10).
- Install spacer (9).
- Fit setscrews (8).
- Tighten to torque.
- See page B-2-4**
- Connect the wiring harness to the injectors.
- Tighten to torque.
- See page B-2-6**

- Fit mechanisms (14 - 15).
- Ensure the position.
- Put spacers (7) into place.
- Fit setscrews (5 - 6).
- Tighten to torque.
- See page B-2-4**

To adjust

Check for the presence of clearance at the rocker arms before making any adjustment.

Loosen locknut **(B)**.

Unscrew adjusting screw **(A)**.

Insert a shim thickness 3.05 ± 0.05 mm, between the piston and the yoke.

Screw up adjusting screw **(A)** until the piston enters into contact with the shim.

Tighten locknut **(B)** to torque.

See page B-2-4

Check the clearance.

Correct, if necessary.

Perform the same operation on all the other cylinders.

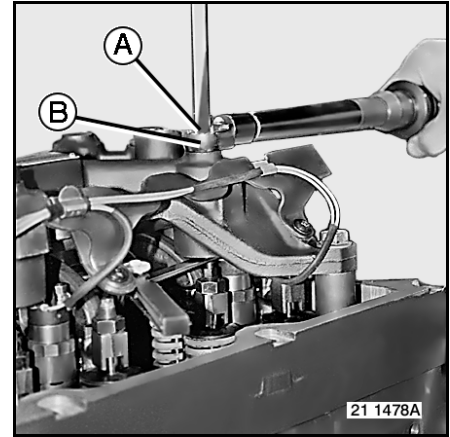

Install the wiring harness complete with bracket **(D)**.

Fit setscrews **(C)**.

Tighten to torque.

See page B-2-2

Fasten the wiring harness in clips **(B)**.

Connect wires **(A)**.

Install seal **(16)**.

Fit rocker cover **(1)**.

Fit washers **(3 - 4)**.

Fit setscrews **(2)**.

Tighten to torque.

See page E-2-1

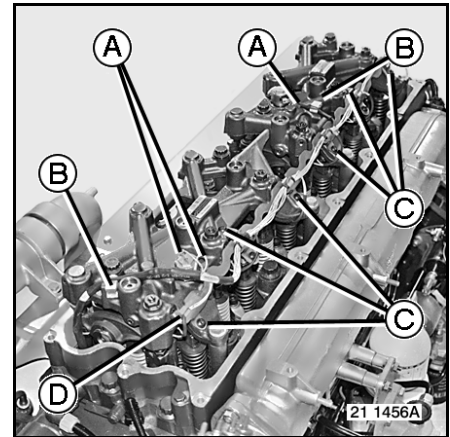

Detailed view

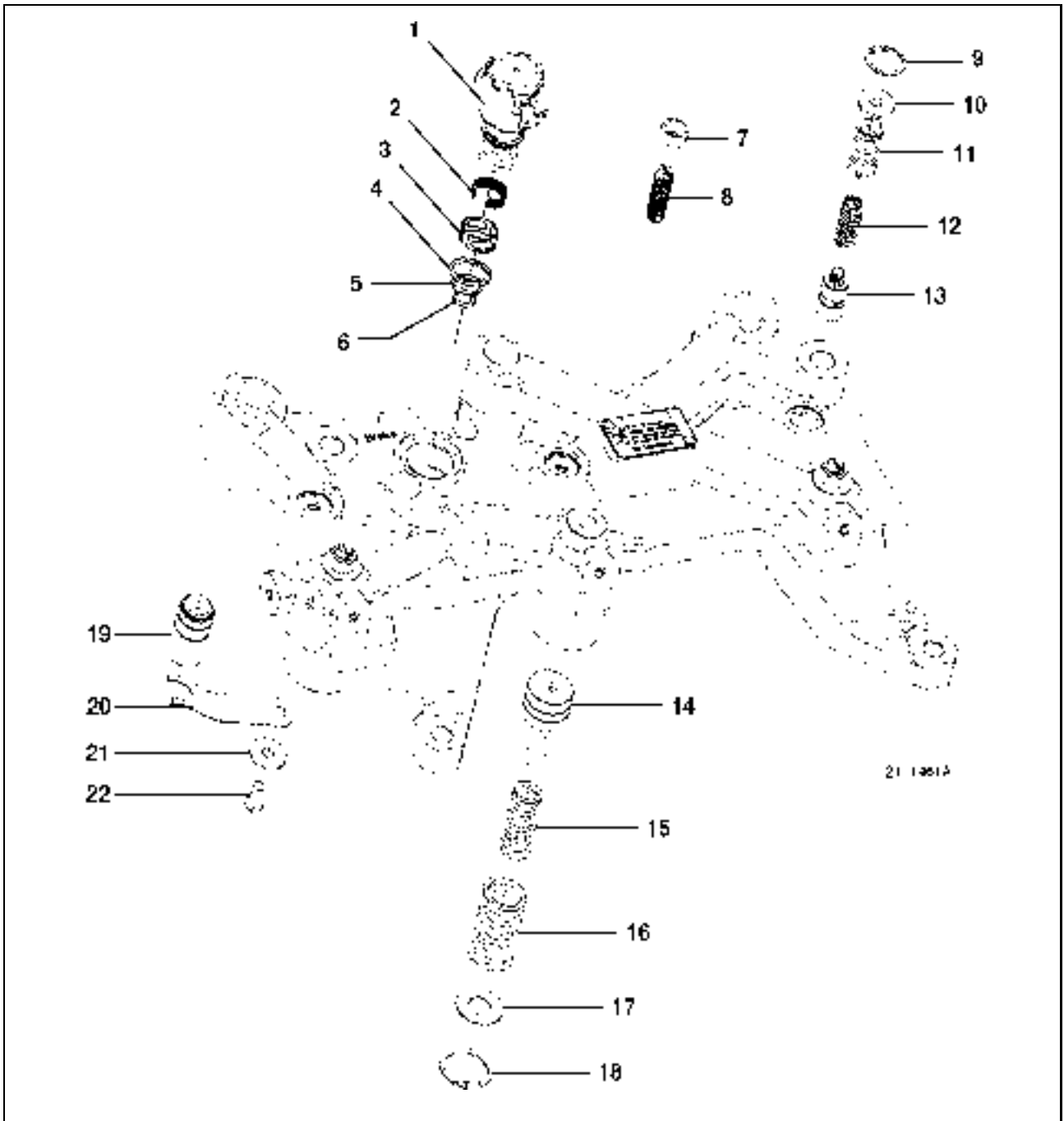

Disassembly

The item numbers indicated in the text refer to the drawing on page O-5.

Solenoid valve

- Unscrew and remove solenoid valve (1).
- Remove gaskets (4 - 5 - 6).
- Withdraw clip (3).
- Take out filter gauze (2).

Control valves

- Compress springs (11 - 12).
- Remove circlip (9).
- Fit nuts (10).
- Take out springs (11 - 12).
- Remove control valve (13).

Transmitter pistons

- Remove setscrew (22).
- Fit nuts (21).
- Take off spring (20).
- Remove the piston (19).

Receiver pistons

- Remove locknut (7).
- Remove adjusting screw (8).
- Compress springs (15 - 16).
- Use a socket **FACOM S11**.
- Remove circlip (18).
- Fit nuts (17).
- Take out springs (15 - 16).
- Remove the piston (14).

Cleaning

- Carefully clean all the parts.
- Clean filter gauze (2).

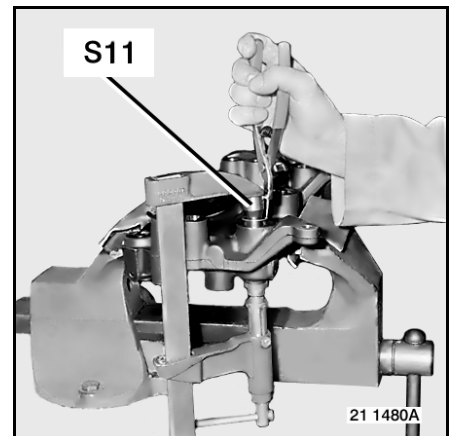
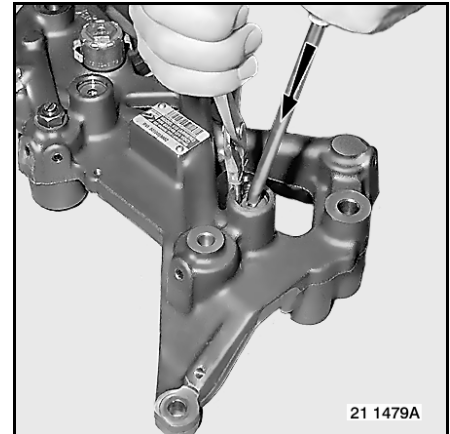

Assembly

The item numbers indicated in the text refer to the drawing on page O-5.

Solenoid valve

Assemble filter gauze (2).

Position clip (3).

Apply oil.

Install seals (4 - 5 - 6).

Screw up solenoid valve (1).

Tighten to torque.

See page B-2-4

Receiver pistons

Apply oil.

Install piston (14).

Match the direction of orientation.

Assemble springs (15 - 16).

Fit washer (17).

Compress springs (15 - 16).

Use a socket **FACOM S11**.

Install circlip (18).

Fit setscrew (8).

Screw up locknut (7).

Tighten to torque.

See page B-2-4

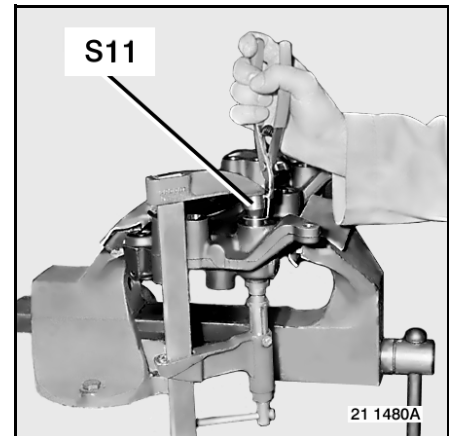

Transmitter pistons

Apply oil.

Install piston (19).

Match the direction of orientation.

Fit spring (20).

Ensure the position.

Fit washer (21).

Fit setscrew (22).

Tighten to torque.

See page B-2-4

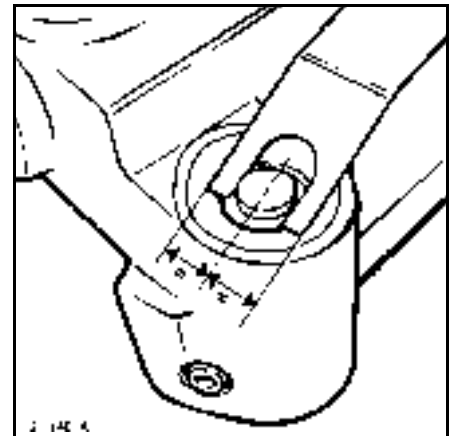

Control valves

Apply oil.

Fit control valve (13).

Assemble springs (11 - 12).

Fit washer (10).

Compress springs (11 - 12).

Install circlip (9).

