

# DAF CF QUICK REFERENCE GUIDE



**CF**

DRIVEN BY QUALITY

TRUCKS | PARTS | FINANCE

[WWW.DAF.COM](http://WWW.DAF.COM)

**DAF**  
A PACCAR COMPANY

# ***DAF CF Quick Reference Guide***



## PREFACE

This Quick Reference Guide consists of sections which in short describe the systems, controls and functions of the truck.

©201604 DAF Trucks N.V., Eindhoven, The Netherlands.

This text has been translated from the English source. Translation may lead to interpretation differences regarding contents and meaning of the written text. Therefore, in case of dispute, the English version of this document shall always be considered the sole and authentic source for determining the contents and meaning of the written text.

In the interest of continuing product development, DAF reserves the right to change specifications or products at any time without prior notice.

No part of this publication may be reproduced and/or published by printing, by photocopying, on microfilm or in any way whatsoever without the prior written consent of DAF Trucks N.V.

## INTRODUCTION

This truck is equipped with advanced features for optimal performance and driver satisfaction.

These features have been designed to help you, and when correctly used, they result in improved fuel efficiency.

To benefit optimally from all these new features it is good to learn about these features, right from the beginning.

Before you start using this truck, read this quick reference guide to help you to realise the maximum benefit in the shortest time possible.



*NOTE: Learn more in the driver's manual or see the videos and animations on the DAF Trucks NV YouTube channel.*



# 1 BEFORE A DRIVE

## Main switch

Switch on the main switch to provide power to the vehicle's systems.

**First switch off the ignition and wait 80 seconds before switching off the main switch.** The after-run phase EAS (Emission Aftertreatment System) must have ended before operating the main switch.

### Mechanical main switch

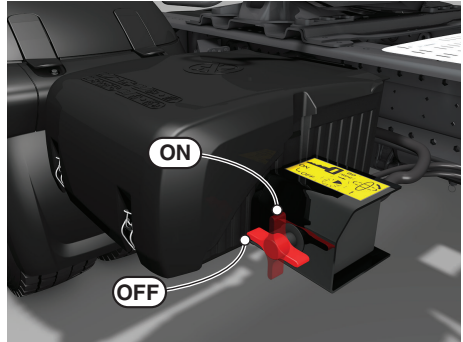

D005026-2

### Electronic main switch

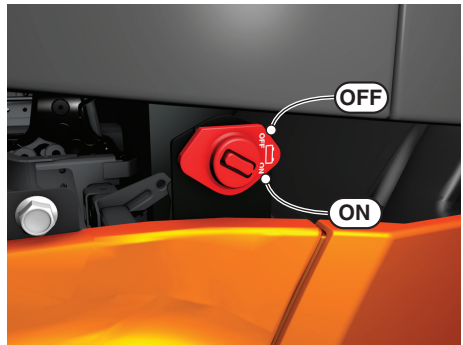

D005008

The electronic main switch also has a switch (1) on the centre console in the cabin.



D005009

## Checks

Always perform the following checks before driving off:

- Possible leaks of vehicle systems (air, engine oil, coolant).
- Wheel attachment and tyre pressures.
- Air filter indicator (on the air filter).
- Windscreen washer fluid level (in the right-hand side door fender).



*NOTE: Use the lever in the top section of the front panel to unlock the front panel.*

- Coolant level (behind the front panel).
- Fuel level.
- AdBlue level.
- Master display for system warnings.
- Engine oil level (on the master display).



*NOTE: Topping up via the filler opening behind the front panel.*

1

## Exterior light check

Press the exterior light check switch (1) on the ignition key or remote control for 2 seconds.



D002221

## Spoiler settings

To minimise fuel consumption, adjust the roof spoiler as indicated.

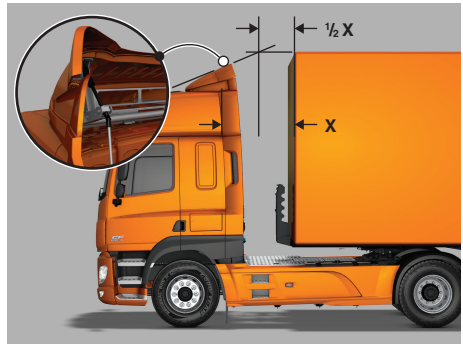

D005002

## Air suspension height settings

Adjust the front and/or rear axle of the vehicle and/or the axles of the trailer to the desired height and store the height. (two 'pre-sets' possible, M1 and M2)



D005010-2

## Mirror settings

Set the chair and safety belt to the desired position.  
Adjust the mirrors at the driver side.

Adjust the mirrors at the co-driver side so the following areas are visible:

- A Wide view mirror
- B Main mirror
- C Kerb mirror
- D Front view mirror

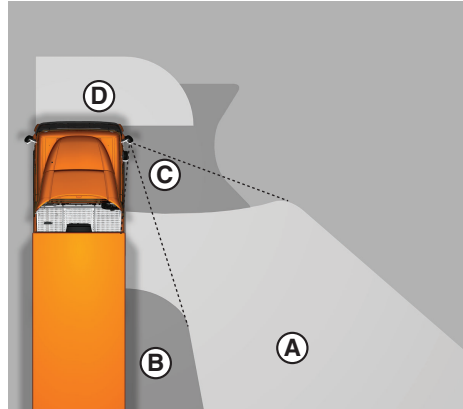

D002222

## Steering column settings

Unlock the steering column and adjust it to the desired position.



D005011

# 1 DRIVING CONTROLS

## Master display

The master display informs you about system warnings and/or vehicle settings.

The colour indicates what the information concerns:

- Red (danger).
- Yellow (warning).
- Blue (settings).
- Grey (information).
- Green (Driver Performance Assistance).



D002228

## Steering column controls

### Left-hand steering column switch

- 1 Horn button.
- 2 Direction indicators, right.
- 3 Direction indicators, left.
- 4 Windscreen washers switch.
- 5 Windscreen wiper switch.
- 6 Main beam.
- 7 Headlight flash.

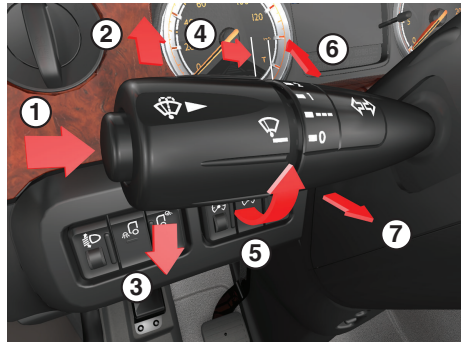

D005012

### Steering wheel switches (SWS)

- 1 Volume control.
- 2 Scroll function.
- 3 Phone control.
- 4 Downhill speed control.
- 5 Variable speed limiter.
- 6 Driving: Cruise control.  
Standstill: Engine Speed Control.



D005013

### Right-hand steering column switch

#### With manual gearbox

- A Version with MX Engine Brake (MEB) or retarder.
- B Version with exhaust brake.
- 1 Eco Mode 'OFF'. If selected, an icon is displayed in the tachometer display.

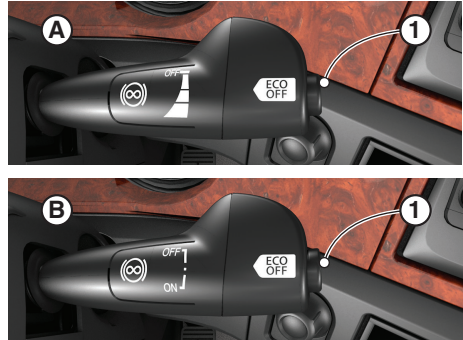

D005014

#### With AS Tronic gearbox

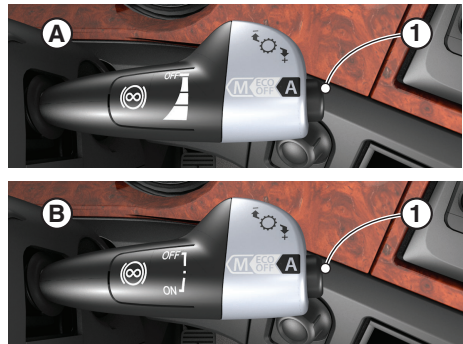

D005015

### Manual gearbox

- 1 Changing half gears (splitting).
- 2 Pre-select the range (low and high range).



D005016-2

# 1 AS Tronic gearbox

- R Reverse mode.
- N Neutral.
- D Drive mode.

The positions with the tortoise symbol are for either the forward or reverse manoeuvring mode.

With switch (1) the Hill Start Aid (HSA) is switched on or off.

The HSA function can be used with an AS Tronic gearbox to drive off at a hill without using the park brake.



D005017-2

## Regenerating DPF

The Emission Aftertreatment System (EAS) is equipped with a Diesel Particulate Filter (DPF) which requires regular regeneration.

Normally regeneration is handled automatically by the vehicle without any driver involvement.

Familiarise yourself with the DPF switch, the three levels of regeneration, their warnings and what action to take. Make sure that you have enough AdBlue for your journey.

### There are three levels of regeneration:

#### Passive regeneration

Automatic regeneration of the DPF above a certain exhaust temperature. No intervention required by the driver and no indication on the master display.

#### Active regeneration

Regeneration when driving, triggered by the engine management system (EMS). No intervention by the driver required.



*NOTE: When at low speed or with the vehicle stationary (during forced stationary regeneration) the yellow coloured high exhaust system temperature (HEST) is shown in the instrument panel. Take care that no people, vehicles, animals or combustible materials are within 2 metres of the exhaust outlet.*



D002232



### Forced stationary regeneration

When Passive and Active Regeneration is not sufficient the system will prompt that a forced stationary regeneration is required.

A forced stationary regeneration is performed at stand-still and triggered by the driver. To prevent the engine derating power, perform regeneration of the DPF as soon as safely possible.

Four different levels of pop-up messages on the master display are possible to warn you the DPF must be regenerated stationary.



#### 1. Soot level high. Regeneration required (yellow).

An alternative to overcome this is to take a motorway route which will clear the soot via passive regeneration.

When ignored, this warning will re-appear at the next key cycles.

#### 2. Soot level too high. Start regeneration immediately (yellow).

Again, to overcome this is to take the motorway route.



#### 3. Soot level full. Regeneration required now (yellow).

The engine derates power and a forced stationary regeneration is required as soon as safely possible.

#### 4. Soot level full. Service required (red).

The engine derates power and an authorised DAF Service dealer must service the vehicle.

It is no longer possible to perform a forced stationary regeneration.

### Safety checks

Before starting a forced stationary regeneration, make sure that following safety checks have been performed:

- The vehicle is parked outside with a minimum of 2 metres clear space around the exhaust outlet.
- The park brake is applied.
- The engine is running at idle speed.
- The vehicle is NOT left unattended.
- The coolant temperature is above 65 degrees.



## 1 Performing forced stationary regeneration

When all safety checks have been met, press (up) the DPF switch (1) once to allow the engine management system (EMS) to carry out a self check. Follow the instructions on the master display. Press the switch (up) again to start the forced stationary regeneration process.



*NOTE: Prevent any regeneration action by switching to 'OFF' (down) when working inside or when entering a hazardous area.*

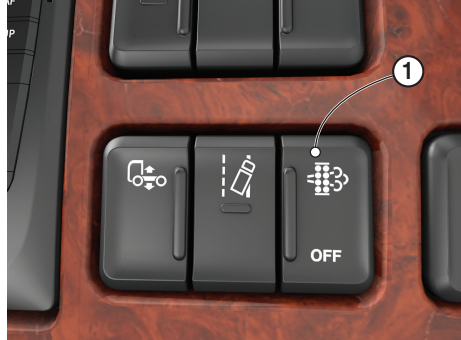

D005018-2

## CONTROLS

### Mirror and window controls

- 1 Adjust mirror button.
- 2 Mirror selection and mirror heater.
- 3 Window control left or right.

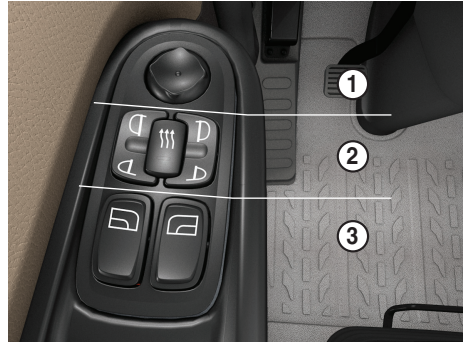

D005019-2

### Dashboard

- 1 Light switch
  - Spring-loaded position (left): Switch off daytime running lights.
  - 0: Lights switched off.
  - 1: Marker lights on.
  - 2: Headlights and marker lights on.
  - Front fog lights: pull out one step.
  - Rear fog lights: pull out two steps.
- 2 Headlight height adjustment (only in combination with halogen headlights)
- 3 Static cornering light.
- 4 Tractor: Working light on the cabin cross member.  
Rigid: Light in the loading space.
- 5 Interior light switch.
- 6 Dimmed instrument lighting.
- 7 Instrument lighting dimmer.
- 8 PTO switches.  
Move the lock upward to release the switch.



D005020

## 1 Master display

- A Interactive and dialogue area.
  - B Indication bar.
  - C Driver Performance Assistant (DPA) status bar.
- 1 Symbol of selected menu.
  - 2 Menu title.
  - 3 Warning indicators.
  - 4 Scroll function available.

The on-board computer system can be accessed using the master display.

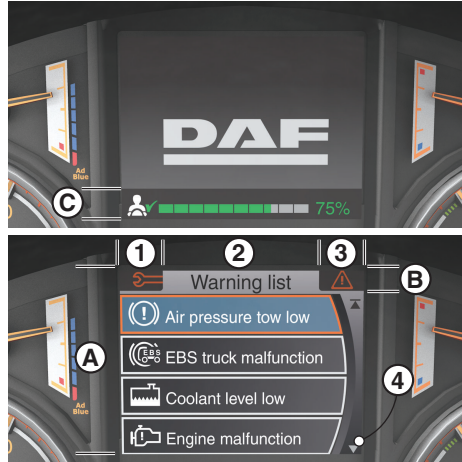

The system is controlled using the Menu Control Switch (MCS). Turn the MCS to select and press to enter a menu, function or setting. Press the Enter key to go back one level or press and hold to exit the menu fully.



**VEHICLE INFO**

- Engine oil level.
- Air supply.
- Tyre Pressure Indication (TPI).
- DPF information.

**DRIVING SUPPORT**

- Economic driving.
- Adaptive Cruise Control (ACC).
- Predictive Cruise Control (PCC).
- Power Take Off (PTO).
- Axle load.
- Speed information.

**SERVICE INFO**

- Warning list.
- Next service.
- Vehicle Identification Number (VIN).
- Total fuel.

**TELEPHONE**

- Truck phone.
- Bluetooth telephone.
- Phone volume.

**SETTINGS**

- Alarm & clock.
- Language.
- Units.
- Dim settings.
- Speed control.
- Tachograph card settings.

**TRIP INFO**

- Drive time.
- Trip 1.
- Trip 2.

## 1 Control panel

- 1 Menu Control Switch.
- 2 Fan speed, rotary knob.
- 3 Air distribution, rotary knob.
- 4 Air temperature control, rotary knob.
- 5 Advanced Emergency Braking System (AEBS) switch.
- 6 Predictive Cruise Control (PCC) switch.
- 7 Adaptive Cruise Control (ACC) switch.
- 8 Diesel Particulate Filter (DPF) switch.
- 9 Lane Departure Warning System (LDWS) switch.
- 10 Driving height switch.
- 11 Flasher hazard warning lights switch.
- 12 Air recirculation switch.
- 13 Air conditioning switch.



D005021-2

## Centre console

- 1 Lock or unlock co-drivers door.
- 2 Depending on the version: Reverse buzzer deactivation switch or silent truck mode switch.
- 3 12V / 5A lighter or accessory connection (maximum 60W).
- 4 24V / 15A accessory connection (maximum 360W).
- 5 USB / AUX plug connection DAF radio.



D005022-2

## Roof console

### Sleeper Cab and Space Cab

1. Auxiliary driving light on roof switch.
2. Rotating light switch.
3. Roof hatch switch.

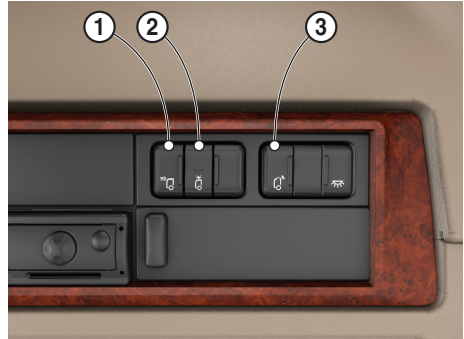

D005023

# 1 AFTER A DRIVE

## Filling fuel tank

Fill the fuel tank or tanks with diesel of the prescribed quality.



*NOTE: When the vehicle is equipped with a duel fuel tank system, fill both fuel tanks separately.*

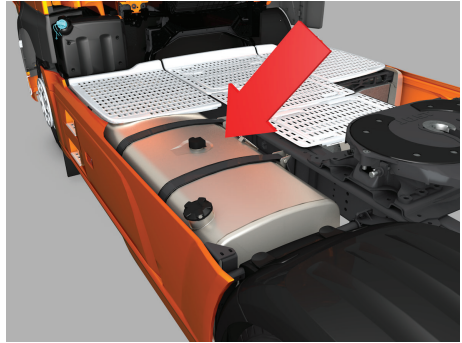

D005024

## Filling AdBlue tank

When filling the AdBlue tank and there is (a chance for) frost, fill it to maximum 75%.

Fill the AdBlue tank with AdBlue of the prescribed quality.

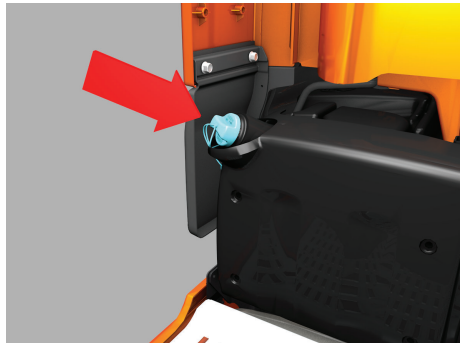

D005025-2

## Leaving the vehicle

Test the vehicle (combination) brakes using the test position of the park brake handle.

Close both doors and press button (1) for more than 2 seconds to initiate comfort locking.



D002243



ISO14001  
Environmental  
Management System



ISO/TS16949  
Quality  
Management System

DRIVEN BY QUALITY