

TECHNICAL DATA	0
DIAGNOSTICS	1
SINGLE REAR AXLE 1132	2
SINGLE REAR AXLE 1339	3
SINGLE REAR AXLE 1347	4
SINGLE REAR AXLE 1354	5
TANDEM REAR AXLE 1132T	6
TANDEM REAR AXLE 1355T	7
TRAILING AXLES	8
HYDRAULIC LIFTING GEAR	9
09N044 LEADING REAR AXLE (FTP VEHICLE)	10



## CONTENTS

	Page	Date
<b>1. SINGLE REAR AXLE 1132</b> .....	1-1 .....	200424
1.1 General .. .. .	1-1 .....	200424
1.2 Tightening torques .....	1-2 .....	200424
1.3 Filling capacities .....	1-2 .....	200424
<b>2. SINGLE REAR AXLE 1339</b> .....	2-1 .....	200424
2.1 General .. .. .	2-1 .....	200424
2.2 Tightening torques .....	2-2 .....	200424
2.3 Filling capacities .....	2-2 .....	200424
<b>3. SINGLE REAR AXLE 1347</b> .....	3-1 .....	200424
3.1 General .. .. .	3-1 .....	200424
3.2 Tightening torques .....	3-2 .....	200424
3.3 Filling capacities .....	3-2 .....	200424
<b>4. SINGLE REAR AXLE 1354</b> .....	4-1 .....	200424
4.1 General .. .. .	4-1 .....	200424
4.2 Tightening torques .....	4-2 .....	200424
4.3 Filling capacities .....	4-2 .....	200424
<b>5. TANDEM REAR AXLE 1132T</b> .....	5-1 .....	200424
5.1 General .. .. .	5-1 .....	200424
5.2 Tightening torques .....	5-2 .....	200424
5.3 Filling capacities .....	5-2 .....	200424
<b>6. TANDEM REAR AXLE 1355T</b> .....	6-1 .....	200424
6.1 General .. .. .	6-1 .....	200424
6.2 Tightening torques .....	6-2 .....	200424
6.3 Filling capacities .....	6-2 .....	200424
<b>7. TANDEM REAR AXLE RT40-145/MT21-144</b> .....	7-1 .....	200424
7.1 General .. .. .	7-1 .....	200424
7.2 Tightening torques .....	7-1 .....	200424
7.3 Filling capacities .....	7-1 .....	200424
<b>8. TRAILING AXLES</b> .....	8-1 .....	200424
8.1 General .. .. .	8-1 .....	200424
8.2 Tightening torques .....	8-2 .....	200424
<b>9. HYDRAULIC LIFTING GEAR</b> .....	9-1 .....	200424
9.1 General .. .. .	9-1 .....	200424
9.2 Tightening torques .....	9-2 .....	200424
<b>10. 09N044 LEADING REAR AXLE (FTP VEHICLE)</b> .....	10-1 .....	200424
10.1 General .. .. .	10-1 .....	200424
10.2 Tightening torques .....	10-2 .....	200424



## 1. SINGLE REAR AXLE 1132

### 1.1 GENERAL

#### Sealant for differential

Mating surface and around bolt holes of axle body

Loctite 5910

#### Sealant for axle shaft

Mating surface of axle shaft flange

Loctite 5910

#### Wheel speed sensor ring

Axial end play

maximum 0.25 mm

#### Installation of wheel hub unit

Axle journal for installing the wheel hub unit treated with

Gleitmo 805

#### Driven axle caster

FA model

4,5°



**1.2 TIGHTENING TORQUES**

The tightening torques stated in this section are different from the standard tightening torques stated in the overview of the standard tightening torques. The other threaded connections not specified must therefore be tightened to the torque stated in the overview of standard tightening torques.

When attachment bolts and nuts are replaced, it is important that - unless stated otherwise - these bolts and nuts are of exactly the same length and property class as those removed.

**Differential**

Drive flange attachment nut	1250 Nm <sup>(1)</sup>
Differential lock cover attachment bolts	30 Nm
Attachment bolts differential to axle housing	170 Nm <sup>(2)</sup>
Torx plug (level check/filler and drain plug)	85 Nm

(1) Use Loctite 262 to secure  
 (2) Apply Loctite 572

**Hub**

Hub nut <sup>(1)</sup>	
1 <sup>st</sup> phase	500 Nm
2 <sup>nd</sup> phase	turn the hub 10 revolutions at a speed of approx. 40 rpm
3 <sup>rd</sup> phase	550 Nm
4 <sup>th</sup> phase	turn the hub 10 revolutions at a speed of approx. 40 rpm
5 <sup>th</sup> phase	1300 Nm
Axle shaft attachment bolts	260 Nm

(1) Only fit a new hub nut

**1.3 FILLING CAPACITIES**

**Differential**

Filling capacity	Minimum caster approx. 15.0 litres	Maximum caster approx. 17.5 litres
------------------	------------------------------------	------------------------------------

## 2. SINGLE REAR AXLE 1339

### 2.1 GENERAL

#### Sealant for differential

Mating surface and around bolt holes of axle body Loctite 5910

#### Sealant for axle shaft

Mating surface of axle shaft flange Loctite 5910

#### Wheel speed sensor ring

Axial end play	maximum 0.25 mm
Driven axle caster	
FAG	3,5°
FAS (11/7 ratio) <sup>(1)</sup>	4°
FAS (10/10 ratio) <sup>(1)</sup>	3,5°
Other	4,5°

(1) With a lowered trailing axle

#### Trailing axle lifting height

Leaf-sprung trailing axle lifting height 100 mm min.

#### Installation of wheel hub unit

Axle journal for installing the wheel hub unit treated with Gleitmo 805



**2.2 TIGHTENING TORQUES**

The tightening torques stated in this section are different from the standard tightening torques stated in the overview of the standard tightening torques. The other threaded connections not specified must therefore be tightened to the torque stated in the overview of standard tightening torques.

When attachment bolts and nuts are replaced, it is important that - unless stated otherwise - these bolts and nuts are of exactly the same length and property class as those removed.

**Differential**

Drive flange attachment nut	1250 Nm <sup>(1)</sup>
Differential lock cover attachment bolts	30 Nm
Attachment bolts differential to axle housing	260 Nm <sup>(2)</sup>
Torx plug (level check/filler and drain plug)	85 Nm

(1) Use Loctite 262 to secure  
 (2) Apply Loctite 572

**Hub**

Hub nut <sup>(1)</sup>	
1 <sup>st</sup> phase	500 Nm
2 <sup>nd</sup> phase rpm	turn the hub 10 revolutions at a speed of approx. 40 rpm
3 <sup>rd</sup> phase	550 Nm
4 <sup>th</sup> phase rpm	turn the hub 10 revolutions at a speed of approx. 40 rpm
5 <sup>th</sup> phase	1300 Nm
Axle shaft attachment bolts	260 Nm

(1) Only fit a new hub nut

**2.3 FILLING CAPACITIES**

**Differential**

Filling capacity	Minimum caster approx. 18.0 litres	Maximum caster approx. 20.0 litres
------------------	------------------------------------	------------------------------------



**3. SINGLE REAR AXLE 1347****3.1 GENERAL****Sealant for differential**

Mating surface and around bolt holes of axle body

Loctite 5910

**Sealant for axle shaft**

Mating surface of axle shaft flange

Loctite 5910

**Wheel speed sensor ring**

Axial end play

maximum 0.25 mm

Driven axle caster

FAG

3,5°

FAS (11/7 ratio)<sup>(1)</sup>

4°

FAS (10/10 ratio)<sup>(1)</sup>

3,5°

Other

4,5°

(1) With a lowered trailing axle

**Trailing axle lifting height**

Leaf-sprung trailing axle lifting height

100 mm min.

Installation of wheel hub unit

Axle journal for installing the wheel hub unit treated with

Gleitmo 805

**3.2 TIGHTENING TORQUES**

The tightening torques stated in this section are different from the standard tightening torques stated in the overview of the standard tightening torques. The other threaded connections not specified must therefore be tightened to the torque stated in the overview of standard tightening torques.

When attachment bolts and nuts are replaced, it is important that - unless stated otherwise - these bolts and nuts are of exactly the same length and property class as those removed.

**Differential gear**

Drive flange attachment nut	1250 Nm <sup>(1)</sup>
Differential lock cover attachment bolts	30 Nm
Attachment bolts differential to axle housing	260 Nm <sup>(2)</sup>
Torx plug (level check/filler and drain plug)	85 Nm

(1) Use Loctite 262 to secure  
 (2) Apply Loctite 572

**Hub**

Hub nut <sup>(1)</sup>	
1 <sup>st</sup> phase	500 Nm
2 <sup>nd</sup> phase rpm	turn the hub 10 revolutions at a speed of approx. 40 rpm
3 <sup>rd</sup> phase	550 Nm
4 <sup>th</sup> phase rpm	turn the hub 10 revolutions at a speed of approx. 40 rpm
5 <sup>th</sup> phase	1300 Nm
Axle shaft attachment bolts	260 Nm

(1) Only fit a new hub nut

**3.3 FILLING CAPACITIES**

<b>Differential</b>	Minimum caster	Maximum caster
Filling capacity	approx. 21.5 litres	approx. 23.5 litres

## 4. SINGLE REAR AXLE 1354

### 4.1 GENERAL

#### Sealant for differential

Mating face and around stud bolts of banjo housing Loctite 5910

#### Wheel bearings

Wheel bearings pre-load:  
frictional force without hub seal 30 - 62 N<sup>(1)</sup>

(1) Measured at the circumference of the hub

#### Wheel speed sensor ring

Axial end play	maximum 0.25 mm
Driven axle caster	
FAG	3,5°
FAS (11/7 ratio) <sup>(1)</sup>	4,0°
FAS (10/10 ratio) <sup>(1)</sup>	3,5°
Other	4,5°

(1) With a lowered trailing axle

#### Trailing axle lifting height

Leaf-sprung trailing axle lifting height 100 mm min.

#### Studs from axle housing

Fit studs with locking compound Loctite 243

**4.2 TIGHTENING TORQUES**

The tightening torques stated in this section are different from the standard tightening torques stated in the overview of the standard tightening torques. The other threaded connections not specified must therefore be tightened to the torque stated in the overview of standard tightening torques.

When attachment bolts and nuts are replaced, it is important that - unless stated otherwise - these bolts and nuts are of exactly the same length and property class as those removed.

**Differential**

Drive flange attachment nut	1325 Nm <sup>(1)</sup>
Locking nut of differential-lock cylinder	80 Nm
Attachment nuts differential to axle housing	260 Nm
Torx plug (level check/filler and drain plug)	85 Nm

(1) Use Loctite 262 to secure

**Hub**

Hub nut	2125 Nm
Locking plate attachment bolts	30 Nm <sup>(1)</sup>
Planet wheel attachment bolts	45 Nm
Hub cap attachment bolts	30 Nm
Torx plug (level check/filler and drain plug)	85 Nm

(1) Use Loctite 243 to secure

**4.3 FILLING CAPACITIES**

**Differential**

Filling capacities	approx. 16.5 litres
--------------------	---------------------

**Hub**

Oil capacity, per hub	2.0 litres
-----------------------	------------

## 5. TANDEM REAR AXLE 1132T

### 5.1 GENERAL

#### Sealant for differential

Mating surface and around bolt holes of axle body

Loctite 5910

#### Sealant for axle shaft

Mating surface of axle shaft flange

Loctite 5910

#### Wheel bearings

Wheel bearing play

0.025 - 0.25 mm

#### Wheel speed sensor ring

Axial end play

maximum 0.2 mm

#### Caster

Caster

5°

**5.2 TIGHTENING TORQUES**

The tightening torques stated in this section are different from the standard tightening torques stated in the overview of the standard tightening torques. The other threaded connections not specified must therefore be tightened to the torque stated in the overview of standard tightening torques.

When attachment bolts and nuts are replaced, it is important that - unless stated otherwise - these bolts and nuts are of exactly the same length and property class as those removed.

**Differential**

First axle drive flanges attachment nut	1385 Nm <sup>(1)</sup>
Second axle drive flanges attachment nut	1250 Nm <sup>(1)</sup>
Differential lock cover attachment bolts	30 Nm
M12 attachment bolts of pinion housing cover	70 Nm <sup>(2)</sup>
Attachment bolts differential to axle housing	170 Nm <sup>(3)</sup>
Torx plug (level check/filler and drain plug)	85 Nm
Hub	
Hub nut (outside nut)	560 Nm
Axle shaft attachment bolts	260 Nm
Torx plug, wheel hub	85 Nm

- (1) Use Loctite 262 to secure
- (2) Use Loctite 243 to secure
- (3) Use Loctite 572 to secure

**5.3 FILLING CAPACITIES**

Differential	Minimum caster	Maximum caster
Filling capacity of 1 <sup>st</sup> axle	approx. 17.0 litres	approx. 25.0 litres
Filling capacity of 2 <sup>nd</sup> axle	approx. 15.0 litres	approx. 17.5 litres

**Hub**

Oil capacity, per hub	0.8 litres
-----------------------	------------

## 6. TANDEM REAR AXLE 1355T

### 6.1 GENERAL

#### Sealant for differential

Mating surface of banjo housing	Loctite 5910
Flanges of attachment nuts and bolts, differential to axle housing	Loctite 5910
Bearing-house cover, input shaft	Loctite 5910

#### Wheel bearings

Wheel bearings pre-load: frictional force without hub seal	30 - 62 N <sup>(1)</sup>
---	--------------------------

(1) Measured at the circumference of the hub

#### Wheel speed sensor ring

Axial end play	maximum 0.2 mm
----------------	----------------

#### Caster

Caster	5°
--------	----

**6.2 TIGHTENING TORQUES**

The tightening torques stated in this section are different from the standard tightening torques stated in the overview of the standard tightening torques. The other threaded connections not specified must therefore be tightened to the torque stated in the overview of standard tightening torques.

When attachment bolts and nuts are replaced, it is important that - unless stated otherwise - these bolts and nuts are of exactly the same length and property class as those removed.

**Differential**

Drive flange attachment bolt	1385 Nm <sup>(1)</sup>
Differential lock cover attachment bolts	30 Nm
Attachment bolts differential to axle housing:	
Attachment bolt M12	110 Nm <sup>(2)</sup>
Attachment bolt M14 x 1.5	200 Nm <sup>(2)</sup>
Attachment bolts of input shaft bearing cover	60 Nm
Torx plug (level check/filler and drain plug)	85 Nm

(1) Use Loctite 262 to secure  
 (2) Use Loctite 243 to secure

**Adjusting the differential lock**

Selector shaft adjusting screw is 0.1 mm under the mating surface of the differential housing at full engaging of the claws.

**Hub**

Hub nut	2125 Nm <sup>(1)</sup>
Locking plate attachment bolts	30 Nm
Planet wheel attachment bolts	45 Nm
Hub cap attachment bolts	30 Nm
Torx plug (level check/filler and drain plug)	85 Nm

(1) Use Loctite 243 to secure

**6.3 FILLING CAPACITIES**

**Differential**

Filling capacity of 1 <sup>st</sup> axle	Minimum caster approx. 13.0 litres	Maximum caster approx. 18.0 litres
Filling capacity of 2 <sup>nd</sup> axle	approx. 11.5 litres	approx. 13.0 litres

**Hub**

Oil capacity, per hub	2.0 litres
-----------------------	------------



## 7. TANDEM REAR AXLE RT40-145/MT21-144

### 7.1 GENERAL

For technical data, please refer to the Meritor product manuals or visit the Meritor web site at "<http://www.arvinmeritor.com>".

### 7.2 TIGHTENING TORQUES

For tightening torques, please refer to the Meritor product manuals or visit the Meritor web site at "<http://www.arvinmeritor.com>".

### 7.3 FILLING CAPACITIES

#### Differential gear

Filling capacity of 1<sup>st</sup> axle

approx. 14.3 litres

Filling capacity of 2<sup>nd</sup> axle

approx. 12.2 litres

**0**

## 8. TRAILING AXLES

### 8.1 GENERAL

#### Installation of wheel hub unit

Axle journal for installing the wheel hub unit treated with

Gleitmo 805



**8.2 TIGHTENING TORQUES**

The tightening torques stated in this section are different from the standard tightening torques stated in the overview of the standard tightening torques. The other threaded connections not specified must therefore be tightened to the torque stated in the overview of standard tightening torques.

When attachment bolts and nuts are replaced, it is important that - unless stated otherwise - these bolts and nuts are of exactly the same length and property class as those removed.

**Hub**

Hub nut of 09N075 trailing axle<sup>(1)</sup>

1 <sup>st</sup> phase	400 Nm
2 <sup>nd</sup> phase	turn the hub 10 revolutions at a speed of approx. 40 rpm
3 <sup>rd</sup> phase	450 Nm
4 <sup>th</sup> phase	turn the hub 10 revolutions at a speed of approx. 40 rpm
5 <sup>th</sup> phase	950 Nm

Hub nut of 09N220 trailing axle<sup>(1)</sup>

1 <sup>st</sup> phase	500 Nm
2 <sup>nd</sup> phase	turn the hub 10 revolutions at a speed of approx. 40 rpm
3 <sup>rd</sup> phase	550 Nm
4 <sup>th</sup> phase	turn the hub 10 revolutions at a speed of approx. 40 rpm
5 <sup>th</sup> phase	1300 Nm

(1) Only fit a new hub nut

**Trailing axle**

Attachment bolts, bearing block to bearing support	260 Nm
Outer bearing block adjusting nut	90 Nm
Pull-rod/push-rod attachment nut	130 Nm

## 9. HYDRAULIC LIFTING GEAR

### 9.1 GENERAL

Cut-out pressure, pressure switch	160 bar
Pre-set value, pressure relief valve	180 bar
Maximum admissible system pressure	200 bar
Test pressure, lifting cylinder	220 bar
Delivery line while lifting	Line connection B
Delivery line while lowering	Line connection A
Safety device	(The characters are printed on the pump unit) Once the trailing axle has been lowered, it can only be lifted again after approx. 2.5 minutes. If the control switch is put into the "lifting" position before approx. 2.5 minutes has elapsed, the lifting gear will not be activated and the time relay will be reset. In that case you will have to wait about another 2.5 minutes before the trailing axle can be lifted.



**9.2 TIGHTENING TORQUES**

The tightening torques stated in this section are different from the standard tightening torques stated in the overview of the standard tightening torques. The other threaded connections not specified must therefore be tightened to the torque stated in the overview of standard tightening torques.

When attachment bolts and nuts are replaced, it is important that - unless stated otherwise - these bolts and nuts are of exactly the same length and property class as those removed.

**Pump unit**

2/2 valve	25 Nm
4/2 valve	25 Nm
Pressure relief valve	30 Nm
Pressure switch	25 Nm
Pump attachment bolts	25 Nm
Engine attachment bolts	17 Nm

**Cylinder**

Piston attachment bolts	200 Nm
-------------------------	--------

---

CF65/75/85 series

09N044 leading rear axle (FTP vehicle)

## 10.09N044 LEADING REAR AXLE (FTP VEHICLE)

### 10.1 GENERAL

Wheel bearing play, 09N044 leading rear axle      0 mm

**0**

**0**

**10.2 TIGHTENING TORQUES**

The tightening torques stated in this paragraph are different from the standard tightening torques stated in the overview of the standard tightening torques. The other threaded connections not specified must therefore be tightened to the torque stated in the overview of standard tightening torques.

When attachment bolts and nuts are replaced, it is important that - unless stated otherwise - these bolts and nuts are of exactly the same length and property class as those removed.

Hub nut	100 Nm <sup>(1)</sup>
Hub cap	500 Nm
U-bolt nut M20, property class 10	553 Nm <sup>(2)</sup>

(1) Turn back until split pin can be fitted.  
 (2) Evenly tighten the two U-bolt nuts alternately.



## CONTENTS

	Page	Date
1. SINGLE REAR AXLE 1132 .....	1-1 .....	200424
1.1 Fault-finding table .....	1-1 .....	200424
2. SINGLE REAR AXLE 1339 .....	2-1 .....	200424
2.1 Fault-finding table .....	2-1 .....	200424
3. SINGLE REAR AXLE 1347 .....	3-1 .....	200424
3.1 Fault-finding table .....	3-1 .....	200424
4. SINGLE REAR AXLE 1354 .....	4-1 .....	200424
4.1 Fault-finding table .....	4-1 .....	200424
5. TANDEM REAR AXLE 1132T .....	5-1 .....	200424
5.1 Fault-finding table .....	5-1 .....	200424
6. TANDEM REAR AXLE 1355T .....	6-1 .....	200424
6.1 Fault-finding table .....	6-1 .....	200424
7. HYDRAULIC LIFTING GEAR .....	7-1 .....	200424
7.1 Fault-finding table .....	7-1 .....	200424



## 1. SINGLE REAR AXLE 1132

### 1.1 FAULT-FINDING TABLE

<b>SYMPTOM: NOISES IN REAR AXLE AND DRIVE ASSEMBLY</b>	
<b>Possible cause</b>	<b>Remedy</b>
Oil level too low	Top up oil
Incorrect oil viscosity	Drain oil and top up
Loosened attachment bolts or broken differential lock parts	Drain oil and check drained oil for presence of pieces of metal
Pinion-bearing play	Adjust and/or replace

<b>SYMPTOM: OIL LEAK</b>	
<b>Possible cause</b>	<b>Remedy</b>
Oil level too high	Drain oil
Incorrect oil viscosity	Drain oil and top up
Leaking oil seal	Replace oil seal
Bleeding system blocked	Clean or replace the bleeding system
Oil leakage between the differential gear housing mating surfaces	Clean mating surfaces and apply new sealant

<b>SYMPTOM: DIFFERENTIAL LOCK IS NOT FUNCTIONING</b>	
<b>Possible cause</b>	<b>Remedy</b>
No air pressure at engaging cylinder	Check compressed-air system
Defective pneumatic control	Check or replace pneumatic switch
Defective mechanical shift control	Check shift control

<b>SYMPTOM: DIFFERENTIAL LOCK WARNING LAMP IS NOT FUNCTIONING</b>	
<b>Possible cause</b>	<b>Remedy</b>
Switch on cylinder fitted too high	Readjust switch
Switch on cylinder defective	Replace switch
Fault in electrical circuit	Check electrical circuit



## 2. SINGLE REAR AXLE 1339

### 2.1 FAULT-FINDING TABLE

<b>SYMPTOM: NOISES IN REAR AXLE AND DRIVE ASSEMBLY</b>	
<b>Possible cause</b>	<b>Remedy</b>
Oil level too low	Top up oil
Incorrect oil viscosity	Drain oil and top up
Loosened attachment bolts or broken differential lock parts	Drain oil and check drained oil for presence of pieces of metal
Pinion-bearing play	Adjust and/or replace

<b>SYMPTOM: OIL LEAK</b>	
<b>Possible cause</b>	<b>Remedy</b>
Oil level too high	Drain oil
Incorrect oil viscosity	Drain oil and top up
Leaking oil seal	Replace oil seal
Bleeding system blocked	Clean or replace the bleeding system
Oil leakage between the differential gear housing mating surfaces	Clean mating surfaces and apply new sealant

<b>SYMPTOM: DIFFERENTIAL LOCK IS NOT FUNCTIONING</b>	
<b>Possible cause</b>	<b>Remedy</b>
No air pressure at engaging cylinder	Check compressed-air system
Defective pneumatic control	Check or replace pneumatic switch
Defective mechanical shift control	Check shift control

<b>SYMPTOM: DIFFERENTIAL LOCK WARNING LAMP IS NOT FUNCTIONING</b>	
<b>Possible cause</b>	<b>Remedy</b>
Switch on cylinder fitted too high	Readjust switch
Switch on cylinder defective	Replace switch
Fault in electrical circuit	Check electrical circuit

**1**

### 3. SINGLE REAR AXLE 1347

#### 3.1 FAULT-FINDING TABLE

<b>SYMPTOM: NOISES IN REAR AXLE AND DRIVE ASSEMBLY</b>	
<b>Possible cause</b>	<b>Remedy</b>
Oil level too low	Top up oil
Incorrect oil viscosity	Drain oil and top up
Loosened attachment bolts or broken differential lock parts	Drain oil and check drained oil for presence of pieces of metal
Pinion-bearing play	Adjust and/or replace

<b>SYMPTOM: OIL LEAK</b>	
<b>Possible cause</b>	<b>Remedy</b>
Oil level too high	Drain oil
Incorrect oil viscosity	Drain oil and top up
Leaking oil seal	Replace oil seal
Bleeding system blocked	Clean or replace the bleeding system
Oil leakage between the differential gear housing mating surfaces	Clean mating surfaces and apply new sealant

<b>SYMPTOM: DIFFERENTIAL LOCK IS NOT FUNCTIONING</b>	
<b>Possible cause</b>	<b>Remedy</b>
No air pressure at engaging cylinder	Check compressed-air system
Defective pneumatic control	Check or replace pneumatic switch
Defective mechanical shift control	Check shift control

<b>SYMPTOM: DIFFERENTIAL LOCK WARNING LAMP IS NOT FUNCTIONING</b>	
<b>Possible cause</b>	<b>Remedy</b>
Switch on cylinder fitted too high	Readjust switch
Switch on cylinder defective	Replace switch
Fault in electrical circuit	Check electrical circuit

**1**



## 4. SINGLE REAR AXLE 1354

### 4.1 FAULT-FINDING TABLE

SYMPTOM: NOISES IN REAR AXLE AND DRIVE ASSEMBLY	
Possible cause	Remedy
Oil level too low	Top up oil
Incorrect oil viscosity	Drain oil and top up
Loosened attachment bolts or broken differential lock parts	Drain oil and check drained oil for presence of pieces of metal
Pinion-bearing play	Adjust and/or replace

SYMPTOM: OIL LEAK	
Possible cause	Remedy
Oil level too high	Drain oil
Incorrect oil viscosity	Drain oil and top up
Leaking oil seal	Replace oil seal
Bleeding system blocked	Clean or replace the bleeding system
Oil leakage between the differential housing mating surfaces	Clean mating surfaces and apply new sealant

SYMPTOM: DIFFERENTIAL LOCK IS NOT FUNCTIONING	
Possible cause	Remedy
No air pressure at engaging cylinder	Check compressed-air system
Defective pneumatic control	Check or replace pneumatic switch
Incorrect setting engaging cylinder	Adjust engaging cylinder
Defective mechanical shift control	Check shift control

SYMPTOM: DIFFERENTIAL LOCK WARNING LAMP IS NOT FUNCTIONING	
Possible cause	Remedy
Defective pressure switch	Replace pressure switch
Fault in electrical circuit	Check electrical circuit

**1**

## 5. TANDEM REAR AXLE 1132T

### 5.1 FAULT-FINDING TABLE

<b>SYMPTOM: NOISES IN REAR AXLE AND DRIVE ASSEMBLY</b>	
<b>Possible cause</b>	<b>Remedy</b>
Oil level too low	Top up oil
Incorrect oil viscosity	Drain oil and top up
Loosened attachment bolts or broken differential lock parts	Drain oil and check drained oil for presence of pieces of metal
Pinion-bearing play	Adjust and/or replace

<b>SYMPTOM: OIL LEAK</b>	
<b>Possible cause</b>	<b>Remedy</b>
Oil level too high	Drain oil
Incorrect oil viscosity	Drain oil and top up
Leaking oil seal	Replace oil seal
Bleeding system blocked	Clean or replace the bleeding system
Oil leakage between the differential gear housing mating surfaces	Clean mating surfaces and apply new sealant

<b>SYMPTOM: DIFFERENTIAL LOCK IS NOT FUNCTIONING</b>	
<b>Possible cause</b>	<b>Remedy</b>
No air pressure at engaging cylinder	Check compressed-air system
Defective pneumatic control	Check or replace pneumatic switch
Defective mechanical shift control	Check shift control

<b>SYMPTOM: DIFFERENTIAL LOCK WARNING LAMP IS NOT FUNCTIONING</b>	
<b>Possible cause</b>	<b>Remedy</b>
Switch on cylinder fitted too high	Readjust switch
Switch on cylinder defective	Replace switch
Fault in electrical circuit	Check electrical circuit



## 6. TANDEM REAR AXLE 1355T

### 6.1 FAULT-FINDING TABLE

<b>SYMPTOM: NOISES IN REAR AXLE AND DRIVE ASSEMBLY</b>	
<b>Possible cause</b>	<b>Remedy</b>
Oil level too low	Top up oil
Incorrect oil viscosity	Drain oil and top up
Loosened attachment bolts or broken differential lock parts	Drain oil and check drained oil for presence of pieces of metal
Pinion-bearing play	Adjust and/or replace

<b>SYMPTOM: OIL LEAK</b>	
<b>Possible cause</b>	<b>Remedy</b>
Oil level too high	Drain oil
Incorrect oil viscosity	Drain oil and top up
Leaking oil seal	Replace oil seal
Bleeding system blocked	Clean or replace the bleeding system
Oil leakage between the differential gear housing mating surfaces	Clean mating surfaces and apply new sealant

<b>SYMPTOM: DIFFERENTIAL LOCK IS NOT FUNCTIONING</b>	
<b>Possible cause</b>	<b>Remedy</b>
No air pressure at engaging cylinder	Check compressed-air system
Defective pneumatic control	Check or replace pneumatic switch
Defective mechanical shift control	Check shift control

<b>SYMPTOM: DIFFERENTIAL LOCK WARNING LAMP IS NOT FUNCTIONING</b>	
<b>Possible cause</b>	<b>Remedy</b>
Switch on cylinder fitted too high	Readjust switch
Switch on cylinder defective	Replace switch
Fault in electrical circuit	Check electrical circuit

**1**

## 7. HYDRAULIC LIFTING GEAR

### 7.1 FAULT-FINDING TABLE

<b>SYMPTOM: TRAILING AXLE DOES NOT LIFT, PUMP MOTOR IS NOT RUNNING</b>	
<b>Possible cause</b>	<b>Remedy</b>
Time between lowering and lifting < 2.5 minutes, causing the time relay to be constantly reset	After lowering the axle wait for more than 2.5 minutes before putting the control switch into the "lifting" position.
Fault in electrical circuit	Check electrical circuit
Defective pump motor	Replace pump motor

<b>SYMPTOM: TRAILING AXLE DOES NOT LIFT, PUMP MOTOR IS OPERATING BUT IS SWITCHED OFF IMMEDIATELY</b>	
<b>Possible cause</b>	<b>Remedy</b>
4/2 valve is not functioning	Check whether the 4/2 valve is activated
Connectors of 4/2 and 2/2 valves have been switched	Check the connection using the wire numbers
Piping kinked	Check piping
Pipe connections on the pump unit have been switched	Check pipe connections

<b>SYMPTOM: TRAILING AXLE IS LIFTED PARTIALLY, PUMP MOTOR IS SWITCHED OFF</b>	
<b>Possible cause</b>	<b>Remedy</b>
Pressure switch activates at too low a pressure	Check pressure switch cut-out pressure and replace switch if necessary
Piping kinked	Check piping
Blocked trailing axle or mechanical linkage of lifting gear	Check the mechanical linkage
In cold weather conditions: oil of incorrect viscosity used	Drain the oil and fill the system with the specified oil

<b>SYMPTOM: TRAILING AXLE IS LIFTED PARTIALLY, PUMP MOTOR CONTINUES TO OPERATE</b>	
<b>Possible cause</b>	<b>Remedy</b>
Not enough oil in the reservoir	Check oil level and top up, if necessary
Opening pressure of pressure relief valve too low or valve is leaking	Check the opening pressure of the pressure relief valve. Adjust or replace the valve
The 4/2 valve is leaking	Check the system pressure and subsequently the 4/2 valve
Insufficient pump delivery due to leakage between pump and valve block, a worn pump or a defective motor	Check the system pressure, the pump and the pump motor

**1**

<b>SYMPTOM: PUMP MOTOR CONTINUES TO OPERATE WHILE THE TRAILING AXLE HAS BEEN FULLY LIFTED OR LOWERED</b>	
<b>Possible cause</b>	<b>Remedy</b>
Pressure relief valve setting too low	Check the opening pressure of the pressure relief valve and adjust the pressure-relief valve
Pressure switch is not functioning	Check the pressure switch and the wiring Replace the pressure switch, if necessary
Fault in electrical circuit	Check electrical circuit

<b>SYMPTOM: TRAILING AXLE DOES NOT LOWER, PUMP MOTOR IS NOT RUNNING</b>	
<b>Possible cause</b>	<b>Remedy</b>
Fault in electrical circuit	Check electrical circuit

<b>SYMPTOM: TRAILING AXLE IS NOT LOWERED, PUMP MOTOR IS OPERATING BUT IS SWITCHED OFF IMMEDIATELY</b>	
<b>Possible cause</b>	<b>Remedy</b>
2/2 valve is not functioning	Check whether the 2/2 valve is activated
Connectors of 2/2 and 4/2 valves have been switched	Check the connection using the wire numbers
Piping kinked	Check piping

<b>SYMPTOM: TRAILING AXLE IS LOWERED QUICKLY, PUMP MOTOR IS NOT OPERATING AND RESERVOIR MAY FLOOD</b>	
<b>Possible cause</b>	<b>Remedy</b>
Fault in electrical circuit	Check electrical circuit
Defective pump motor	Repair or replace pump motor

<b>SYMPTOM: TRAILING AXLE IS LOWERED AUTOMATICALLY ONCE LIFTED</b>	
<b>Possible cause</b>	<b>Remedy</b>
External oil leakage	Check piping, piping connections, pump unit and cylinders for leakage
Bad sealing of the 2/2 valve or of the non-return valve built into of the 2/2 valve	Check pump unit for internal leakage and subsequently inspect the 2/2 valve
Internal leakage of one of the cylinders	Check the cylinders for internal leakage



## CONTENTS

	Page	Date
<b>1. GENERAL</b> .....	1-1	200424
1.1 Description .....	1-1	200424
1.2 Overview drawing, wheel hub unit .....	1-2	200424
<b>2. INSPECTION AND ADJUSTMENT</b> .....	2-1	200424
2.1 Checking the differential oil level .....	2-1	200424
2.2 Checking the operation of the differential lock .....	2-2	200424
2.3 Checking the wheel speed sensor ring .....	2-2	200424
<b>3. REMOVAL AND INSTALLATION</b> .....	3-1	200424
3.1 Removal and installation, entire rear axle .....	3-1	200424
3.2 Removal and installation, axle shafts .....	3-2	200424
3.3 Removal and installation, wheel hub unit .....	3-4	200424
3.4 Removal and installation, wheel speed sensor ring .....	3-8	200424
3.5 Removal and installation, drive flange .....	3-9	200424
3.6 Removal and installation, pinion oil seal .....	3-10	200424
3.7 Removal and installation, differential .....	3-11	200424
3.8 Removal and installation, differential lock .....	3-12	200424
<b>4. DRAINING AND FILLING</b> .....	4-1	200424
4.1 Draining and filling, differential .....	4-1	200424



## 1. GENERAL

### 1.1 DESCRIPTION

#### Differential

The differential has a hypoid bevel gear.

A single reduction is applied.

The bevel gear-to-pinion backlash is achieved using adjusting nuts.

The pinion housing can be removed using jacking screws.

The pinion bearing is adjusted using shims which are placed between the inner bearing races.

#### Differential lock

The differential is equipped with a variable differential lock.

The right side of the satellite-gear housing flange is fitted with spline tothing. The left side of the selector sleeve is equipped with similar tothing. The selector sleeve is fitted with splines, similar to the splines in the axle shaft.

The outside of the selector sleeve is fitted with a groove, in which a fork fits which is attached to the engaging cylinder.

If the engaging cylinder is pressurised using a pneumatic switch, the tothing of the selector sleeve will mesh with the tothing of the satellite-gear housing.

If the engaging cylinder is vented via the pneumatic switch, the spring will ensure that the lock is deactivated.

#### Wheel hub unit

The wheel hub, wheel bearings in compact version and hub oil seal form a unit, also called the wheel hub unit (3).

The thrust washer (2) installed between the hub nut (1) and wheel bearing, is fitted with two straight surfaces on the inside to prevent the washer from turning. This is to prevent the hub nut (1) from loosening in case of wheel bearing problems. The hub nut (1) is of the self-locking type. The nut is locked by bending the lips on the hub nut outward.

The wheel bearings of the wheel hub unit are greased and are maintenance free.

The correct wheel bearing pre-load is achieved by installing the hub nut as specified.

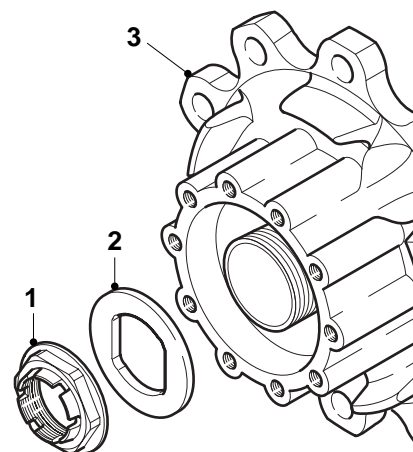

A8 00 356

## 1.2 OVERVIEW DRAWING, WHEEL HUB UNIT

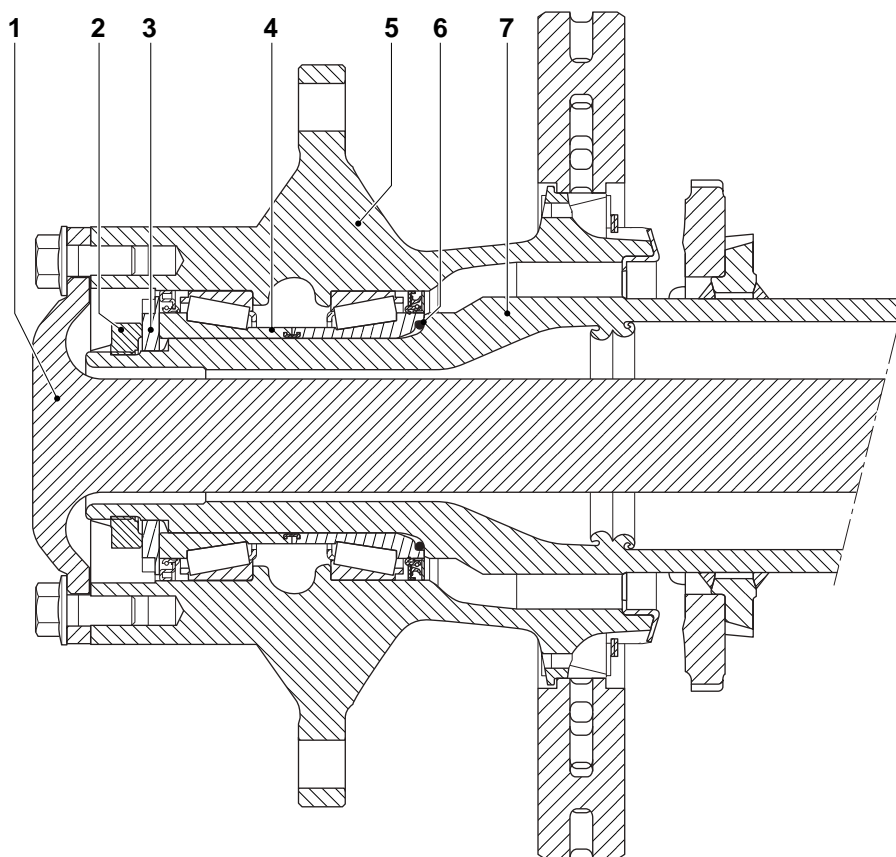

A8 00 341

- 1. Axle shaft
- 2. Hub nut
- 3. Thrust washer
- 4. Compact bearings
- 5. Hub
- 6. O-ring
- 7. Axle journal

2

## 2. INSPECTION AND ADJUSTMENT

### 2.1 CHECKING THE DIFFERENTIAL OIL LEVEL



To prevent skin injury, avoid unnecessary contact with the drained oil.

1. Position the vehicle on a level surface.
2. Lower the trailing axle, if present, on a leaf-sprung version.
3. Remove the oil-level check/filler plug (A). The oil level should reach the level check/filler opening.
4. Fit the plug using the special tool (DAF no. 1329493) and tighten the plug to the specified tightening torque. See "Technical data".

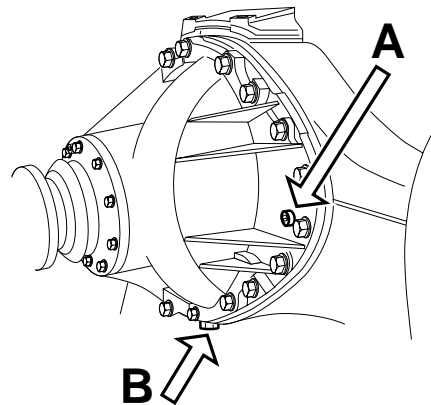

M8013

## 2.2 CHECKING THE OPERATION OF THE DIFFERENTIAL LOCK

1. Jack up the rear axle and support the axle on stands.
2. Bring the air system to operating pressure.
3. Engage the differential lock. The warning lamp should now come on.
4. Check that there is a "rigid" connection between the driven wheels.
5. Disengage the differential lock. The warning lamp should not light up and the "rigid" connection between the driven wheels should be broken.

## 2.3 CHECKING THE WHEEL SPEED SENSOR RING

1. Remove the wheel hub unit.
2. Check the sensor ring (2) for deposits. Special attention should be paid to deposits between the teeth of the sensor ring. Clean the sensor ring if necessary.
3. Check the sensor ring (2) for damage. Even the slightest damage can cause a failure. If necessary replace the sensor ring.
4. If possible, the sensor ring (2) should be checked for the maximum admissible axial end play. See "Technical data".
5. Check the sensor (1) for freedom of movement. If necessary, clean the sensor (1) and apply new grease.

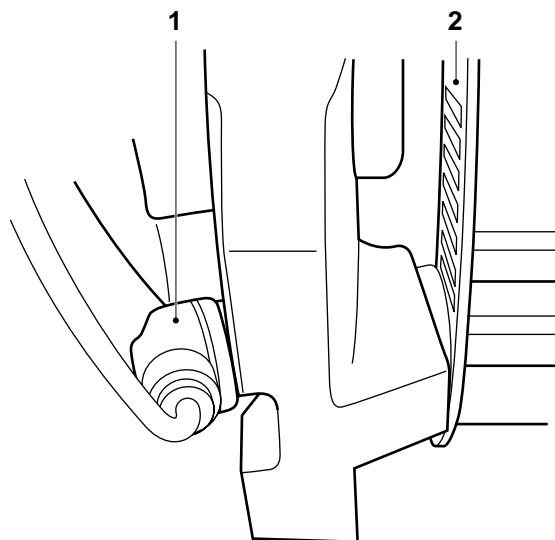

A8 00 342

### 3. REMOVAL AND INSTALLATION

#### 3.1 REMOVAL AND INSTALLATION, ENTIRE REAR AXLE

##### Removing the entire rear axle

1. Block the front wheels using chocks.
2. Slacken the central bolt of the spring-brake cylinder as much as possible.
3. Apply the parking brake.
4. Remove the air pipes and wiring.
5. Remove the prop shaft from the drive flange.
6. Loosen the shock absorbers on the bottom.
7. Support the vehicle securely with stands under the chassis side members.
8. Remove the axle suspension/guide. Take precautionary measures to make sure that the axle does not tilt during removal of the axle suspension/guide.
9. If possible, the entire rear axle with wheels should be rolled from under the vehicle.

##### Installing the entire rear axle

1. Install the entire rear axle with wheels under the vehicle.
2. Fit the axle suspension/guide.
3. Fit the shock absorbers.
4. Fit the prop shaft to the drive flange.
5. Connect the electrical wiring and fit the air pipes.
6. Tighten the central bolt of the spring-brake cylinder.

### 3.2 REMOVAL AND INSTALLATION, AXLE SHAFTS

#### Removing axle shafts

1. Jack up the rear axle and support the axle on stands.
2. Engage the differential lock. Check whether the axle is blocked. Replace the switch by the special tool (DAF no. 1329447), see (A). This is to prevent the sliding sleeve from falling into the differential when removing the axle shaft.

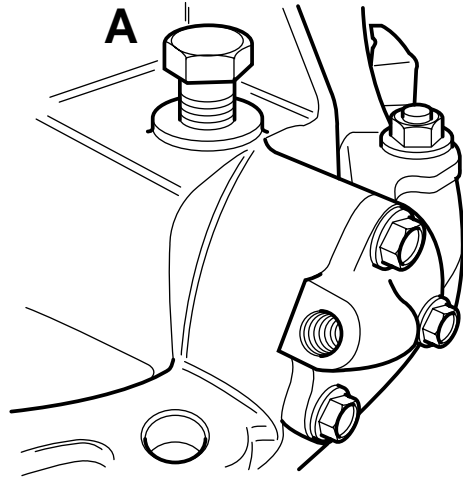

A800139

3. Remove the axle-shaft attachment bolts.
4. Remove the axle shaft using special tool (DAF no. 0694980), if required, see (B). When the axle shaft comes loose, a small amount of oil may leak out. Collect this oil.

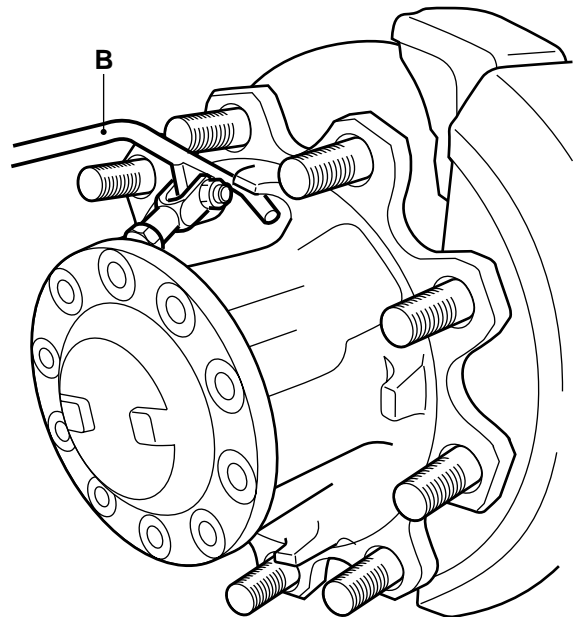

A8 00 351



**Installing axle shafts**

1. Clean the mating surfaces of the axle shaft flange and wheel hub unit.
2. Apply sealant to the mating surface of the axle shaft flange. See "Technical data".
3. Fit the axle shaft. Tighten the axle shaft attachment bolts to the specified tightening torque, see "Technical data".
4. Activate the differential lock and remove the special tool from the differential lock. Install the switch.

**3.3 REMOVAL AND INSTALLATION, WHEEL HUB UNIT**

**2**

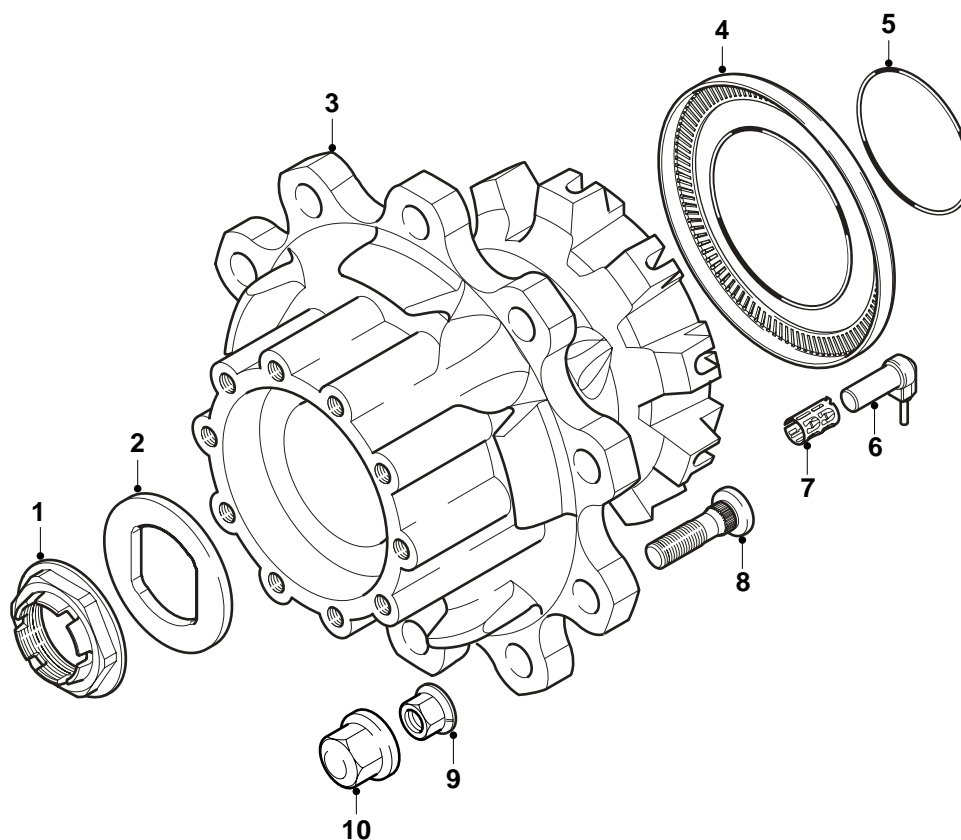

A8 00 348

**Removing the wheel hub unit**

1. Jack up the rear axle and support the axle on stands.
2. Remove the wheels.
3. Remove the brake calliper.
4. Remove the axle shaft.
5. Remove the hub nut (1) using the hub nut wrench (A), which is part of the special tool set (DAF no. 1329496). Loosen the hub nut (1), using a torque amplifier to do so.
6. Remove the thrust washer (2).

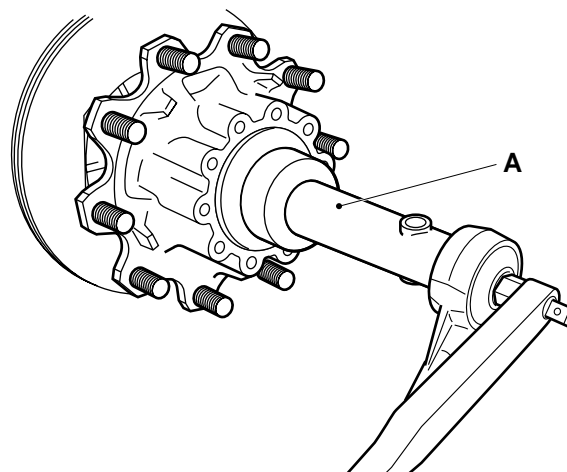

A8 00 405

7. Install the guide sleeve (A), which is part of the special tool set (DAF no. 1329496), on the axle journal.
8. Attach the wheel hub unit (3) securely to a movable lifting device.
9. Slide the wheel hub unit (3) from the axle journal using the lifting device.
10. Take care that the wheel hub unit (3) does not rest on the guide bush (A) as the latter is not strong enough to take the weight of the wheel hub unit (3).

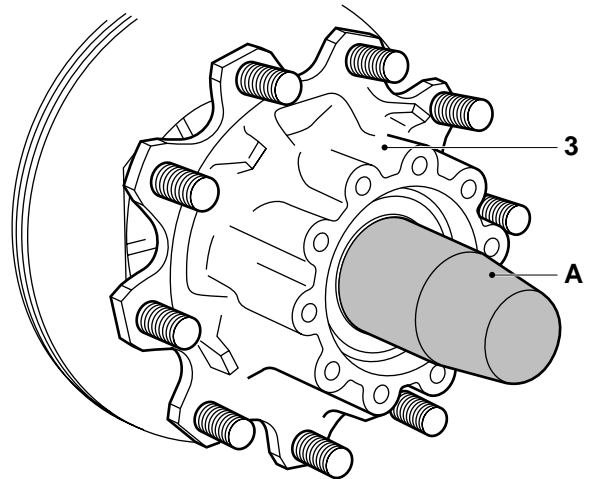

A8 00 345

#### Installing the wheel hub

1. Check the wheel speed sensor and the oil seals in the wheel hub unit (3) for damage.
2. Check the axle journal thread carefully for damage.



**You must never fit a wheel hub on an axle journal with a damaged thread.**

3. Fit the O-ring (5) into the wheel hub unit.

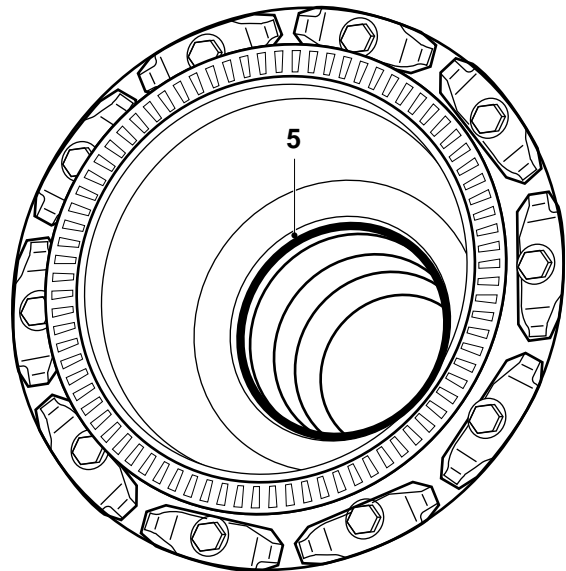

A8 00 350

# 2

- Apply a thin and even layer of the prescribed lubricant to the axle journal, see "Technical data".

**Note:**

Do not overlubricate the axle journal. While fitting the wheel hub unit, the excess grease will collect at the backside of the wheel hub. When the vehicle is used in daily operation, this anti-corrosion agent can leak out so that it looks as if the oil seal leaks.

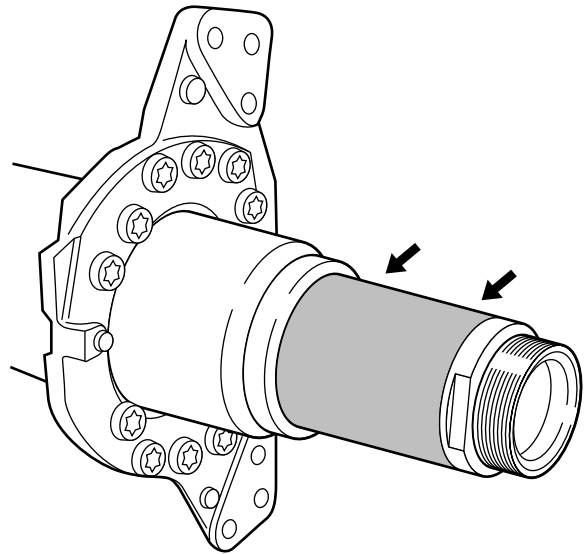

A8 00 344

- Install the guide sleeve (A), which is part of the special tool set (DAF no. 1329496), on the axle journal.

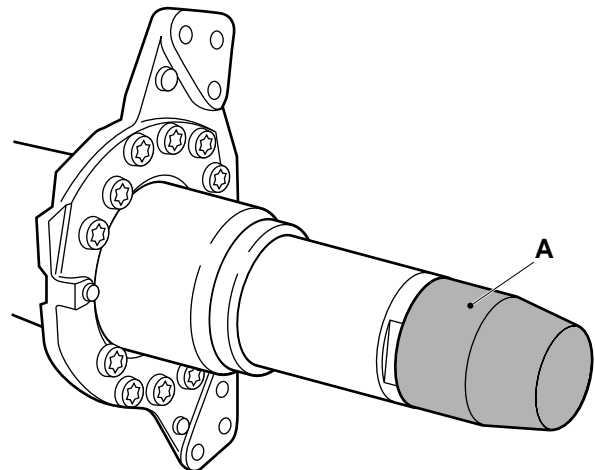

A8 00 343

- Attach the wheel hub unit (3) securely to a movable lifting device.
- Position the wheel hub unit (3) exactly in front of the axle journal using the movable lifting device. Slide the wheel hub unit (3) on the axle journal. Take care that the wheel hub unit (3) does not rest on the guide bush as the latter is not strong enough to take the weight of the wheel hub unit (3).
- Fit the thrust washer (2).
- Replace the hub nut (1). Apply a few drops of oil to the abutting surface of the hub nut (1). Fit the hub nut (1).

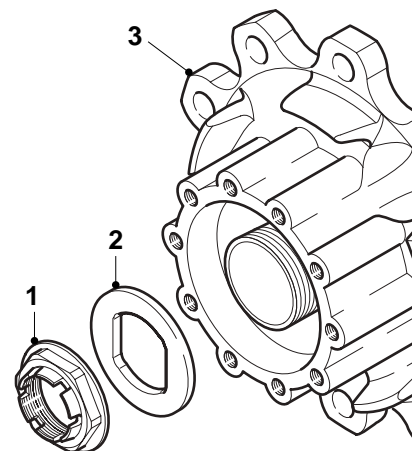

A8 00 356

10. Tighten the hub nut (1) using the hub nut wrench (A), which is part of the special tool set (DAF no. 1329496). Tighten the hub nut (1) in the specified manner using a torque amplifier, see "Technical data".

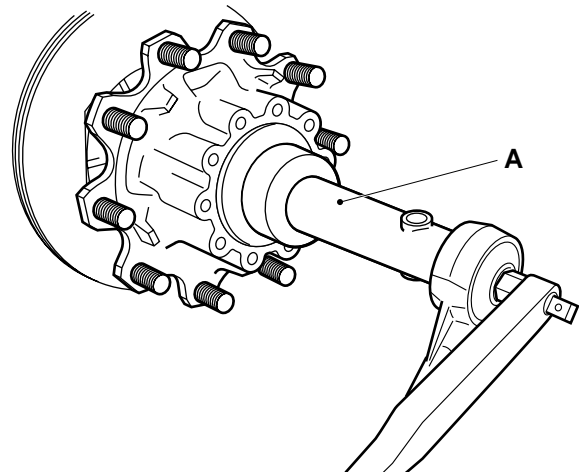

A8 00 405

11. Press the wheel speed sensor (1) up against the sensor ring (2). While the vehicle is being driven, the air gap between the sensor and the sensor ring is adjusted automatically.
12. Fit the axle shaft.
13. Fit the brake calliper.
14. Put the wheels back on.

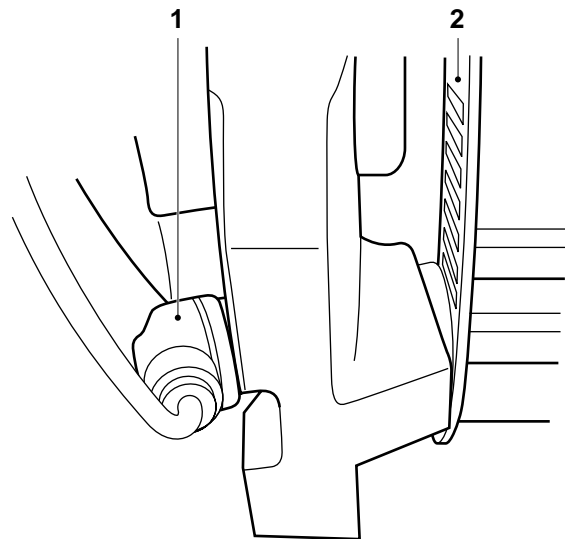

A8 00 342

### 3.4 REMOVAL AND INSTALLATION, WHEEL SPEED SENSOR RING

#### Removing the wheel speed sensor ring

1. Remove the wheel hub unit from the axle journal.
2. Use a driving tool to carefully tap the sensor ring from the inside from the wheel hub unit. Make sure that the wheel hub unit is not damaged in the process.



**Once removed, a sensor ring should not be re-installed.**

#### Installing the wheel speed sensor ring

1. Check the mating surfaces of sensor ring and wheel hub unit for damage.
2. Check the new sensor ring carefully for possible damages in transit.
3. Use a flat plate and a press to fit the sensor ring to the wheel hub unit. Press the sensor ring evenly on the wheel hub unit until it fully abuts.
4. Install the wheel hub unit on the axle journal.
5. Press the wheel speed sensor (1) up against the sensor ring (2). While the vehicle is being driven, the air gap between the sensor and the sensor ring is adjusted automatically.

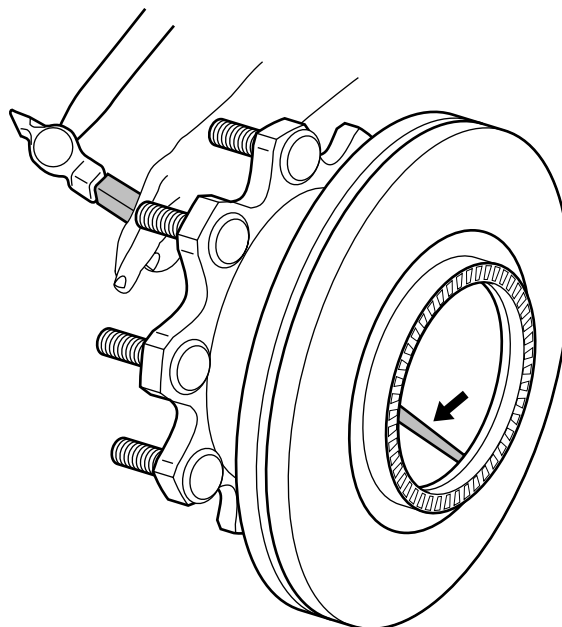

A8 00 359

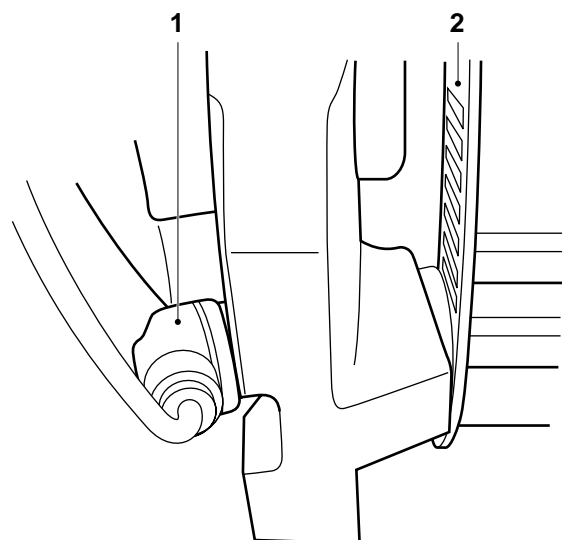

A8 00 342

### 3.5 REMOVAL AND INSTALLATION, DRIVE FLANGE

#### Removing the drive flange

1. Remove the prop shaft from the drive flange.
2. Fit the special tool (B) (DAF no. 0484977) on the drive flange to prevent the flange from rotating. Remove the drive-flange nut using a torque amplifier (A).
3. Remove the drive flange. If necessary, use a puller.

#### Installing the drive flange

1. Before installation check the drive flange along the oil-seal running surface for grooves and/or sharp edges. If required, replace the drive flange.
2. Fit the drive flange.
3. Apply a small amount of grease to the first turn of the drive-flange nut.
4. Apply locking compound to the screw thread. See "Technical data".
5. Fit the special tool (B) (DAF no. 0484977) on the drive flange to prevent the flange from rotating. Fit the drive-flange nut. Use a torque amplifier (A) to tighten the drive-flange nut to the specified tightening torque, see "Technical data".
6. Fit the prop shaft to the drive flange.

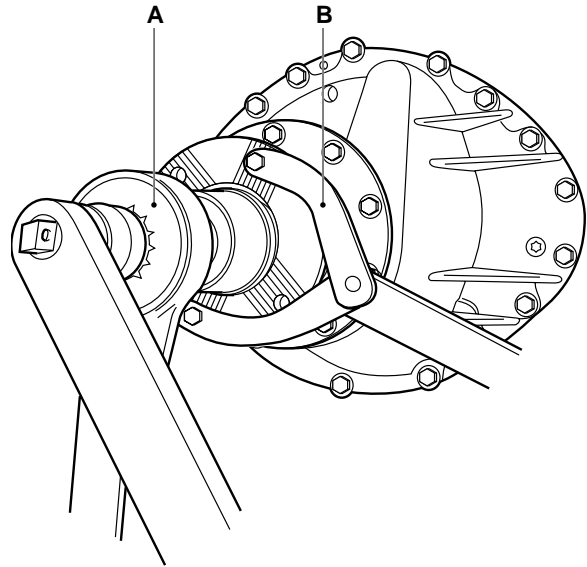

A8 00 357

### 3.6 REMOVAL AND INSTALLATION, PINION OIL SEAL

#### Removing the pinion oil seal

1. Remove the drive flange.
2. Drill two holes into the seal and screw the special tool (B) (DAF no. 0484899) into the seal. Pull the oil seal from the pinion housing using the special tool (A) (DAF no. 0694928).

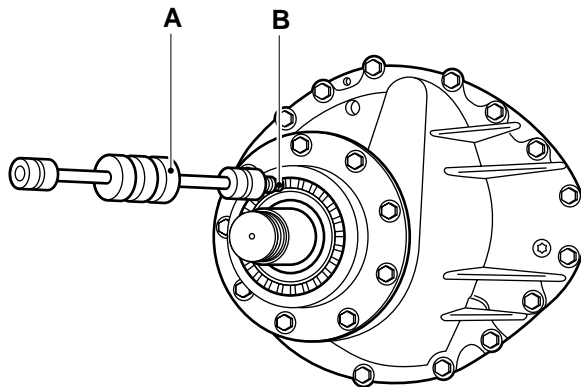

A8 00 360

#### Installing the pinion oil seal

1. Use the special tool (DAF no. 1240452) to fit the seal so that the inscription "outside" is pointed outwards.
2. Fit the drive flange.



### 3.7 REMOVAL AND INSTALLATION, DIFFERENTIAL

#### Removing the differential

1. Drain the oil from the differential, see "Draining and filling".
2. Remove the prop shaft from the drive flange.
3. Remove the axle shafts.
4. Remove the air connection for the differential lock.
5. Attach the differential securely to a lifting device.
6. Remove the attachment bolts from the differential.
7. Remove the differential from the axle housing using two jacking screws.

#### Installing the differential

1. Clean the mating surfaces of the axle housing and the differential housing. Re grind the mating faces lightly. Do not damage the mating faces in the process.
2. Clean and degrease the attachment bolts. Apply locking compound to the attachment bolts. See "Technical data".
3. Apply a thin, even layer of sealant to the mating surface and around the bolt holes of the axle housing, see "Technical data".
4. Fit the differential into the axle housing. Install the attachment bolts and tighten them evenly. Tighten the attachment bolts to the specified torque. See "Technical data".
5. Fit the air connection to the differential lock.
6. Fit the axle shafts.
7. Fit the prop shaft to the drive flange.
8. Fill the differential with oil, see "Draining and filling".

3.8 REMOVAL AND INSTALLATION, DIFFERENTIAL LOCK

Removing the differential lock

1. Remove the differential.



**Do not come near the selector sleeve when de-aerating the differential lock.**

2. Pressurise the air connection of the differential lock. Remove the special tool (A). Evenly de-aerate the differential lock.
3. Remove the attachment bolts (1) from the cylinder cover (2). Remove the cover.

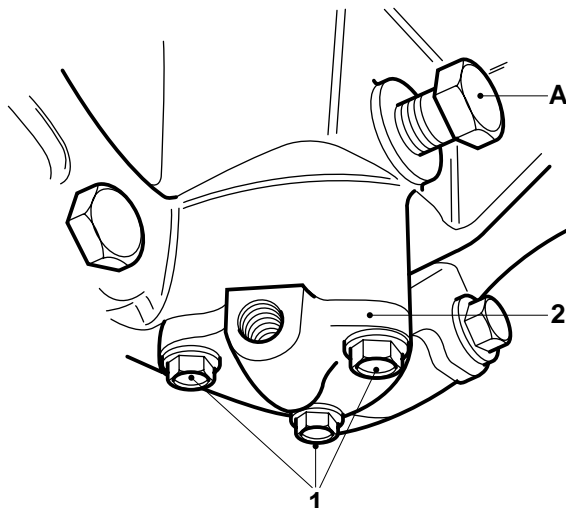

A8 00 353

4. Remove the piston (5).
5. Remove the shifting fork (3) and the sliding sleeve (1) with the spring (2).

Installing the differential lock

1. Fit the shifting fork (3) and the sliding sleeve (1) with the spring (2).

**Note:**

Make sure that the flat side (see arrow) of the shifting fork (3) points towards the piston (5).

2. Apply a small amount of oil to the piston (5) sealing ring (4).
3. Install the piston (5).
4. Install the cylinder cover and tighten the attachment bolts evenly. Tighten the attachment bolts to the specified tightening torque, see "Technical data".

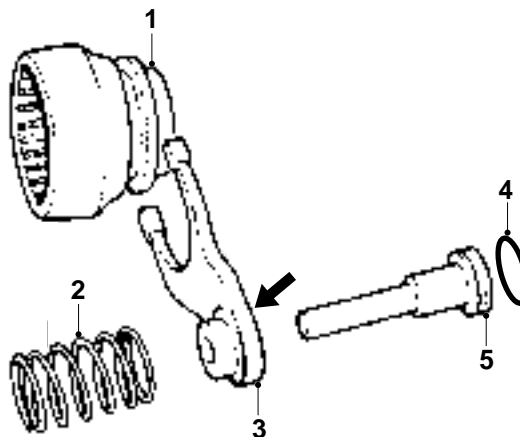

A8 00 354

2



**Do not come near the selector sleeve when de-aerating the differential lock.**

5. Pressurise the air connection of the differential lock. Fit special tool (A) (DAF no. 1329447), so that the differential lock is blocked.
6. Install the differential.

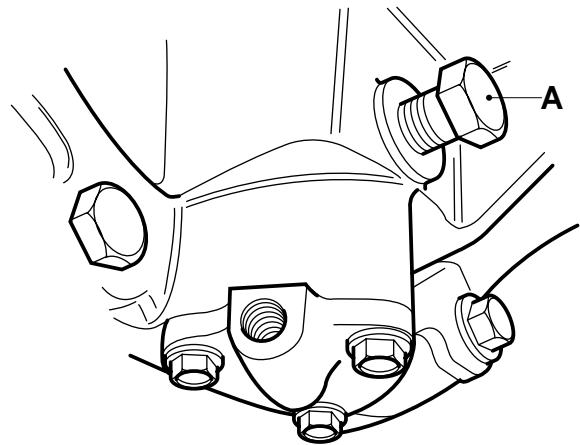

A8 00 346

**2**

## 4. DRAINING AND FILLING

### 4.1 DRAINING AND FILLING, DIFFERENTIAL



To prevent skin injury, avoid unnecessary contact with the drained oil.

#### Draining the differential

1. Position the vehicle on a level surface.
2. Remove the level check/filler plug (A) and drain plug (B). Drain the oil.
3. Fit the drain plug (B) using the special Torx wrench (DAF no. 1329493) and tighten to the specified torque; see "Technical data".

#### Filling the differential

1. Fill the differential via the level check/filler plug (A) with the specified quantity of oil, see "Technical data".
2. Check the oil level after approx. 5 minutes. The oil level should now have reached the level check/filler opening. See "Inspection and adjustment".
3. Fit the level check/filler plug (A) using the special Torx wrench (DAF no. 1329493) and tighten to the specified torque; see "Technical data".

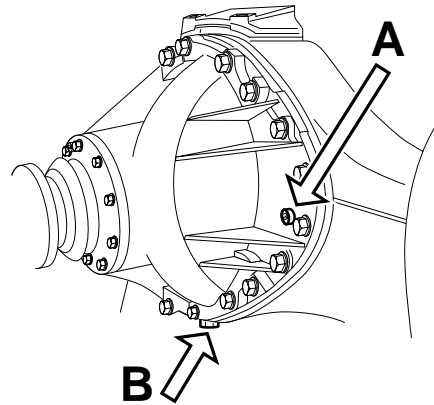

M8013

**2**

## CONTENTS

	Page	Date
<b>1. GENERAL</b> .....	1-1	200424
1.1 Description .....	1-1	200424
1.2 Overview drawing, wheel hub unit .....	1-2	200424
<b>2. INSPECTION AND ADJUSTMENT</b> .....	2-1	200424
2.1 Checking the differential oil level .....	2-1	200424
2.2 Checking the operation of the differential lock .....	2-2	200424
2.3 Checking the wheel speed sensor ring .....	2-2	200424
2.4 Inspection and adjustment, caster .....	2-3	200424
<b>3. REMOVAL AND INSTALLATION</b> .....	3-1	200424
3.1 Removal and installation, entire rear axle .....	3-1	200424
3.2 Removal and installation, axle shafts .....	3-2	200424
3.3 Removal and installation, wheel hub unit .....	3-4	200424
3.4 Removal and installation, wheel speed sensor ring .....	3-8	200424
3.5 Removal and installation, drive flange .....	3-9	200424
3.6 Removal and installation, pinion oil seal .....	3-10	200424
3.7 Removal and installation, differential .....	3-11	200424
3.8 Removal and installation, differential lock .....	3-12	200424
<b>4. DRAINING AND FILLING</b> .....	4-1	200424
4.1 Draining and filling, differential .....	4-1	200424





## 1. GENERAL

### 1.1 DESCRIPTION

#### Differential

The differential has a hypoid bevel gear.

A single reduction is applied.

The bevel gear-to-pinion backlash is achieved using adjusting nuts.

The pinion housing can be removed using jacking screws.

The pinion bearing is adjusted using shims which are placed between the inner bearing races.

#### Differential lock

The differential is equipped with a variable differential lock.

The right side of the satellite-gear housing flange is fitted with spline tothing. The left side of the selector sleeve is equipped with similar tothing. The selector sleeve is fitted with splines, similar to the splines in the axle shaft.

The outside of the selector sleeve is fitted with a groove, in which a fork fits which is attached to the engaging cylinder.

If the engaging cylinder is pressurised using a pneumatic switch, the tothing of the selector sleeve will mesh with the tothing of the satellite-gear housing.

If the engaging cylinder is vented via the pneumatic switch, the spring will ensure that the lock is deactivated.

#### Wheel hub unit

The wheel hub, wheel bearings in compact version and hub oil seal form a unit, also called the wheel hub unit (3).

The thrust washer (2) installed between the hub nut (1) and wheel bearing, is fitted with two straight surfaces on the inside to prevent the washer from turning. This is to prevent the hub nut (1) from loosening in case of wheel bearing problems. The hub nut (1) is of the self-locking type. The nut is locked by bending the lips on the hub nut outward.

The wheel bearings of the wheel hub unit are greased and are maintenance free.

The correct wheel bearing pre-load is achieved by installing the hub nut as specified.

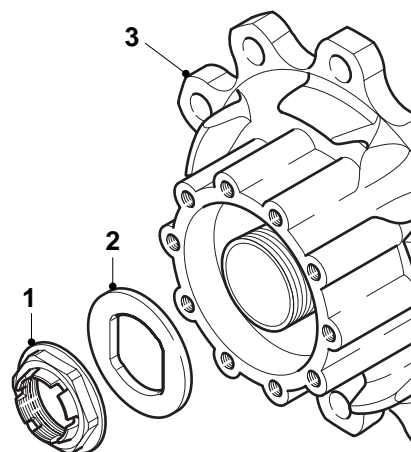

A8 00 356

1.2 OVERVIEW DRAWING, WHEEL HUB UNIT

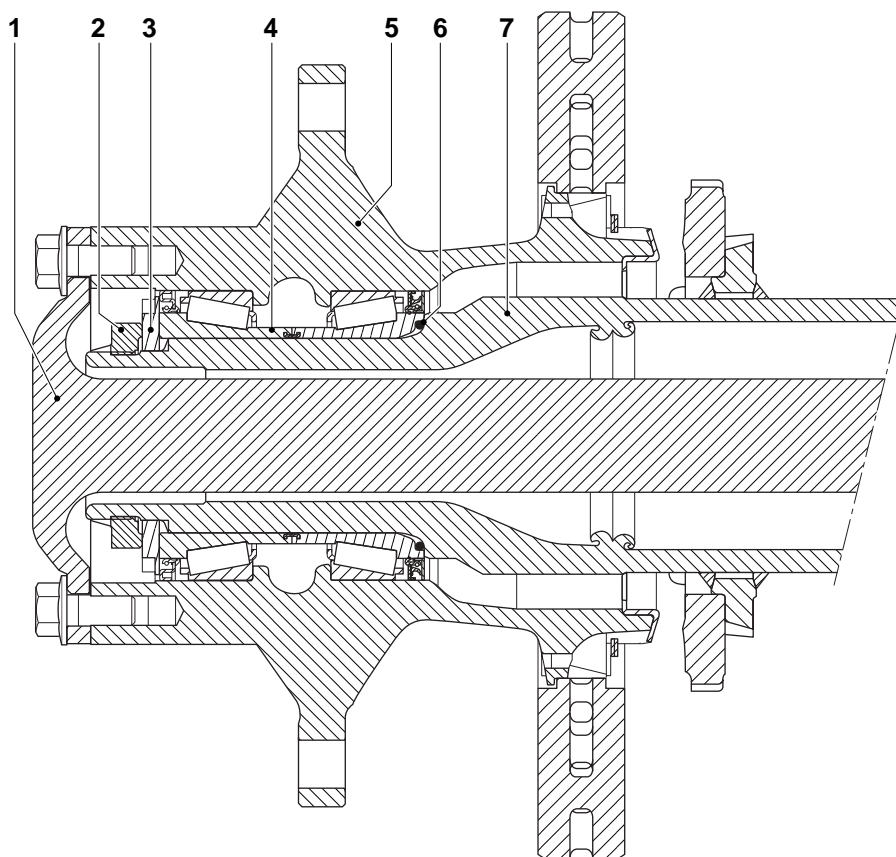

3

- 1. Axle shaft
- 2. Hub nut
- 3. Thrust washer
- 4. Compact bearings
- 5. Hub
- 6. O-ring
- 7. Axle journal

A8 00 341

## 2. INSPECTION AND ADJUSTMENT

### 2.1 CHECKING THE DIFFERENTIAL OIL LEVEL



To prevent skin injury, avoid unnecessary contact with the drained oil.

1. Position the vehicle on a level surface.
2. Lower the trailing axle, if present, on a leaf-sprung version.
3. Remove the oil-level check/filler plug (A). The oil level should reach the level check/filler opening.
4. Fit the plug using the special tool (DAF no. 1329493) and tighten the plug to the specified tightening torque. See "Technical data".

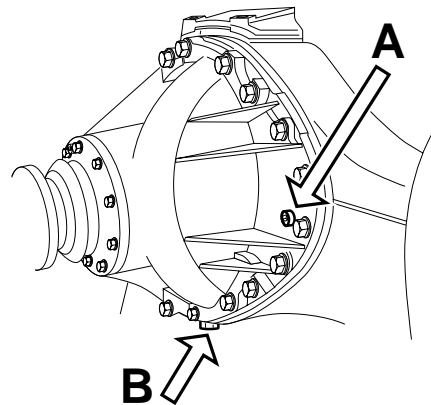

M8013

## 2.2 CHECKING THE OPERATION OF THE DIFFERENTIAL LOCK

1. Jack up the rear axle and support the axle on stands.
2. Bring the air system to operating pressure.
3. Engage the differential lock. The warning lamp should now come on.
4. Check that there is a "rigid" connection between the driven wheels.
5. Disengage the differential lock. The warning lamp should not light up and the "rigid" connection between the driven wheels should be broken.

3

## 2.3 CHECKING THE WHEEL SPEED SENSOR RING

1. Remove the wheel hub unit.
2. Check the sensor ring (2) for deposits. Special attention should be paid to deposits between the teeth of the sensor ring. Clean the sensor ring if necessary.
3. Check the sensor ring (2) for damage. Even the slightest damage can cause a failure. If necessary replace the sensor ring.
4. If possible, the sensor ring (2) should be checked for the maximum admissible axial end play. See "Technical data".
5. Check the sensor (1) for freedom of movement. If necessary, clean the sensor (1) and apply new grease.

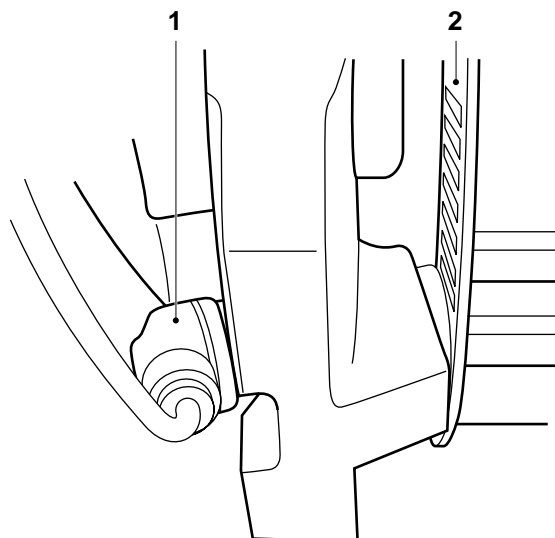

A8 00 342

## 2.4 INSPECTION AND ADJUSTMENT, CASTER

### Checking the caster

1. Place the vehicle on a flat surface.
2. Try to achieve a nominal axle load with the trailing axle on the ground.
3. Remove the prop shaft from the differential.
4. Place an angle gauge on the drive flange and measure the caster of the axle relative to the chassis side member. See "Technical data" for the specified caster.

### Adjusting the caster, leaf-sprung trailing axle

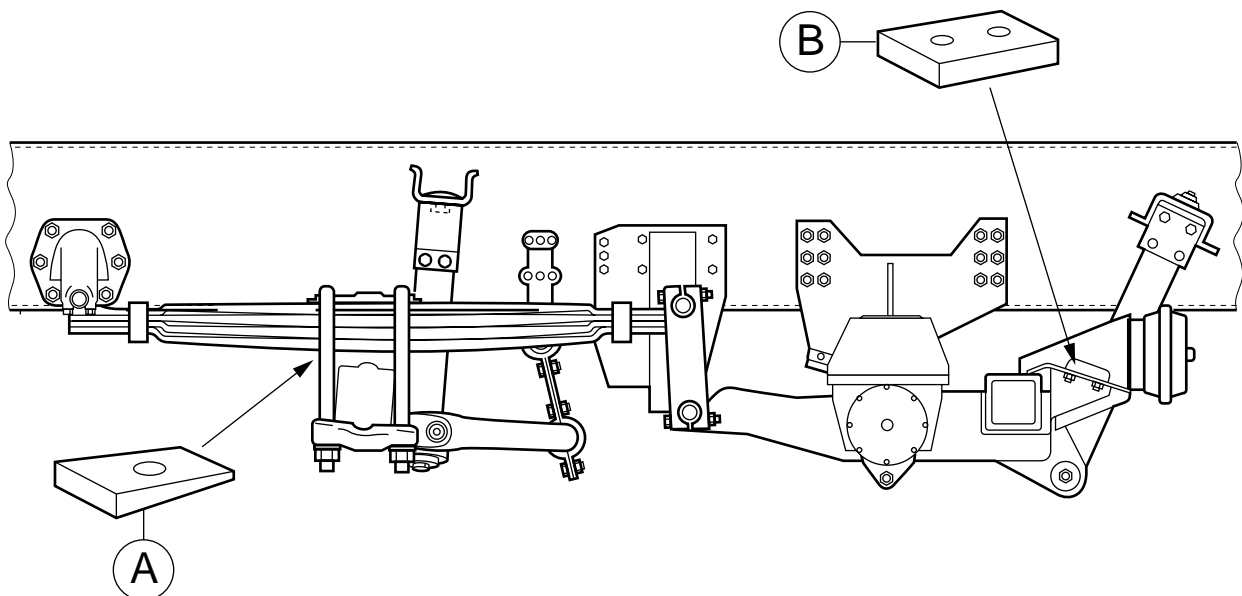

A8 00 292

#### Note:

The lowering of the lifting height of the trailing axle reduces the caster. See "Technical data" for the minimum lifting height of the trailing axle.

1. Fit a block (B) (can be made by yourself) under the stop block.
2. Fit the stop block.
3. If the correction made by this process is insufficient, the caster must be corrected on the driven axle.

### Adjusting the caster, driven axle

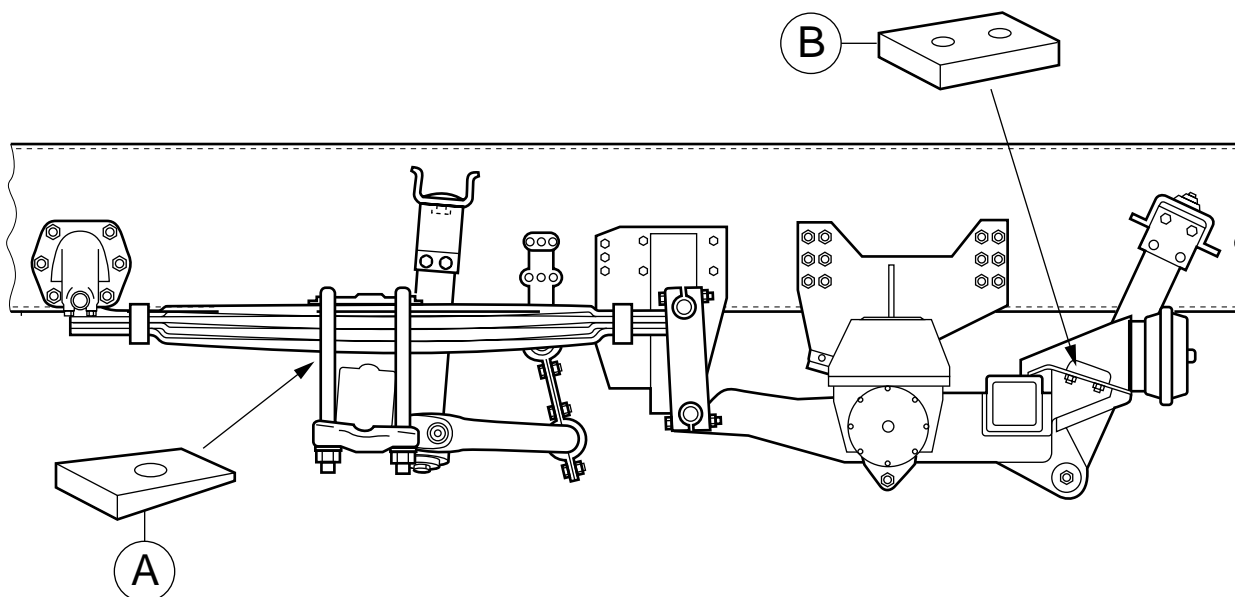

3

1. Jack up the chassis in such a way that the driven axle is free.

A8 00 292

**Note:**

Ensure that both the chassis and axle are well supported with stands.

2. Loosen the U-bolt nuts so that the correct key can be fitted to position (A).
3. Tighten the U-bolt nuts evenly on both sides to the specified torque.
4. Check the caster again.

### 3. REMOVAL AND INSTALLATION

#### 3.1 REMOVAL AND INSTALLATION, ENTIRE REAR AXLE

##### Removing the entire rear axle

1. Block the front wheels using chocks.
2. Slacken the central bolt of the spring-brake cylinder as much as possible.
3. Apply the parking brake.
4. Remove the air pipes and wiring.
5. Remove the prop shaft from the drive flange.
6. Loosen the shock absorbers on the bottom.
7. Support the vehicle securely with stands under the chassis side members.
8. Remove the axle suspension/guide. Take precautionary measures to make sure that the axle does not tilt during removal of the axle suspension/guide.
9. If possible, the entire rear axle with wheels should be rolled from under the vehicle.

##### Installing the entire rear axle

1. Install the entire rear axle with wheels under the vehicle.
2. Fit the axle suspension/guide.
3. Fit the shock absorbers.
4. Fit the prop shaft to the drive flange.
5. Connect the electrical wiring and fit the air pipes.
6. Tighten the central bolt of the spring-brake cylinder.

### 3.2 REMOVAL AND INSTALLATION, AXLE SHAFTS

#### Removing axle shafts

1. Jack up the rear axle and support the axle on stands.
2. Engage the differential lock. Check whether the axle is blocked. Replace the switch by the special tool (DAF no. 1329447), see (A). This is to prevent the sliding sleeve from falling into the differential when removing the axle shaft.

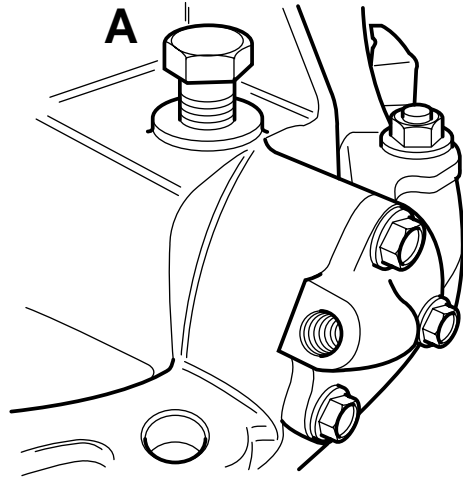

A800139

3. Remove the axle-shaft attachment bolts.
4. Remove the axle shaft using special tool (DAF no. 0694980), if required, see (B). When the axle shaft comes loose, a small amount of oil may leak out. Collect this oil.

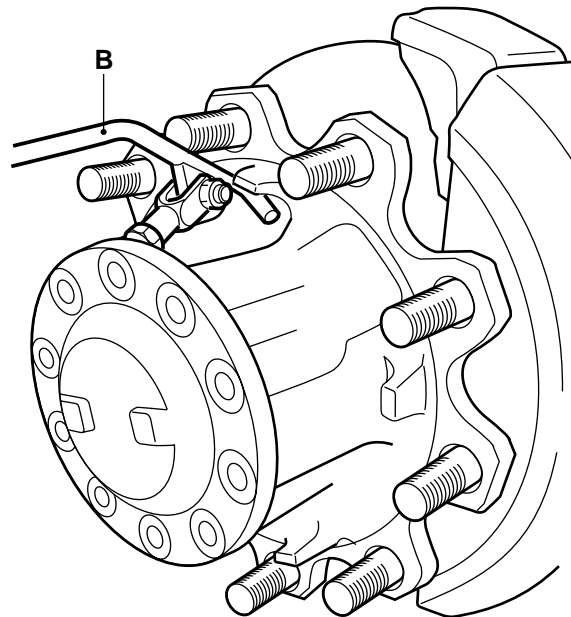

A8 00 351



**Installing axle shafts**

1. Clean the mating surfaces of the axle shaft flange and wheel hub unit.
2. Apply sealant to the mating surface of the axle shaft flange. See "Technical data".
3. Fit the axle shaft. Tighten the axle shaft attachment bolts to the specified tightening torque, see "Technical data".
4. Activate the differential lock and remove the special tool from the differential lock. Install the switch.

**3.3 REMOVAL AND INSTALLATION, WHEEL HUB UNIT**

**3**

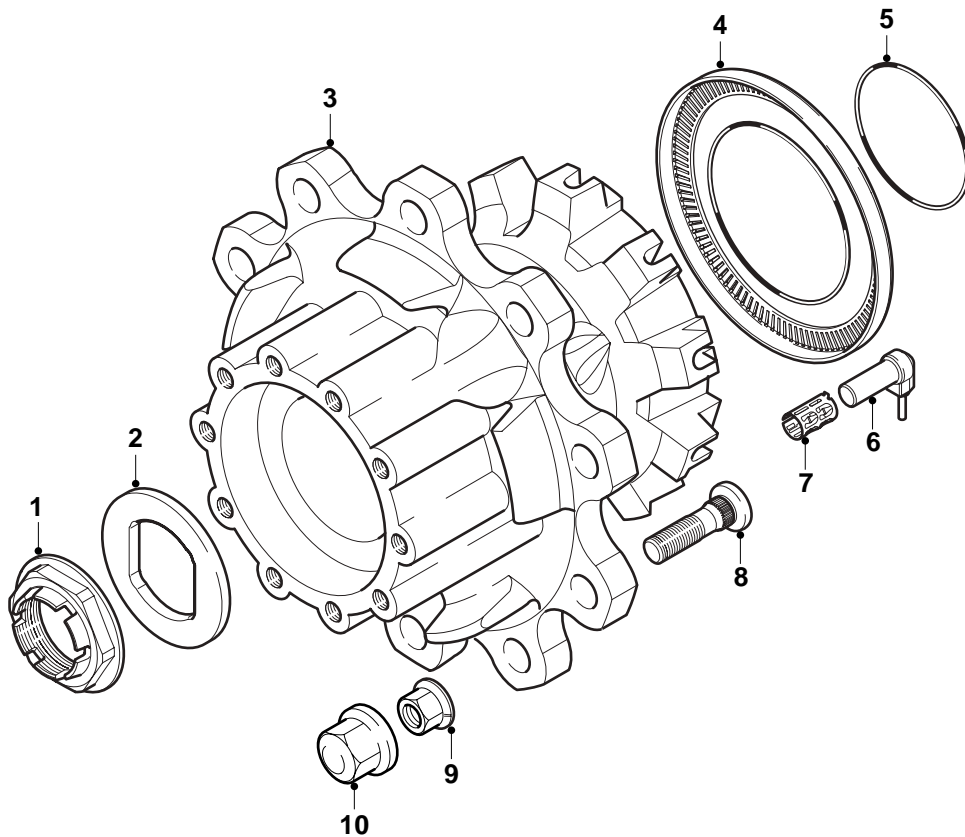

A8 00 348

**Removing the wheel hub unit**

1. Jack up the rear axle and support the axle on stands.
2. Remove the wheels.
3. Remove the brake calliper.
4. Remove the axle shaft.
5. Remove the hub nut (1) using the hub nut wrench (A), which is part of the special tool set (DAF no. 1329496). Loosen the hub nut (1), using a torque amplifier to do so.
6. Remove the thrust washer (2).

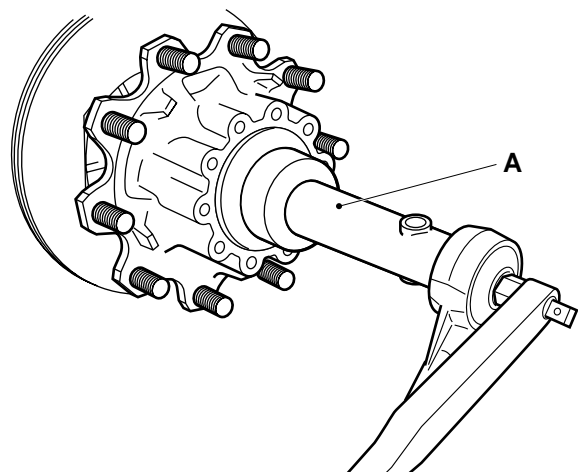

A8 00 405

7. Install the guide sleeve (A), which is part of the special tool set (DAF no. 1329496), on the axle journal.
8. Attach the wheel hub unit (3) securely to a movable lifting device.
9. Slide the wheel hub unit (3) from the axle journal using the lifting device.
10. Take care that the wheel hub unit (3) does not rest on the guide bush (A) as the latter is not strong enough to take the weight of the wheel hub unit (3).

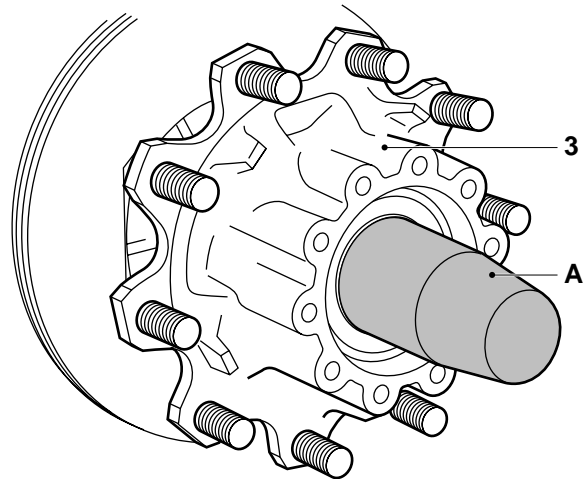

A8 00 345

3

#### Installing the wheel hub

1. Check the wheel speed sensor and the oil seals in the wheel hub unit (3) for damage.
2. Check the axle journal thread carefully for damage.



**You must never fit a wheel hub on an axle journal with a damaged thread.**

3. Fit the O-ring (5) into the wheel hub unit.

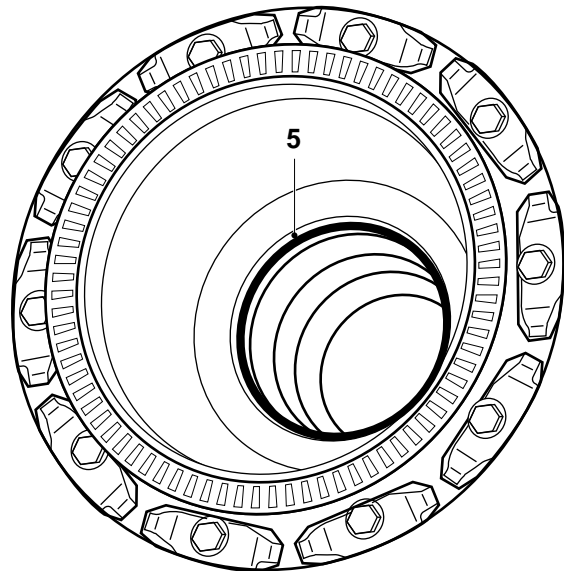

A8 00 350

4. Apply a thin and even layer of the prescribed lubricant to the axle journal, see "Technical data".

**Note:**

Do not overlubricate the axle journal. While fitting the wheel hub unit, the excess grease will collect at the backside of the wheel hub. When the vehicle is used in daily operation, this anti-corrosion agent can leak out so that it looks as if the oil seal leaks.

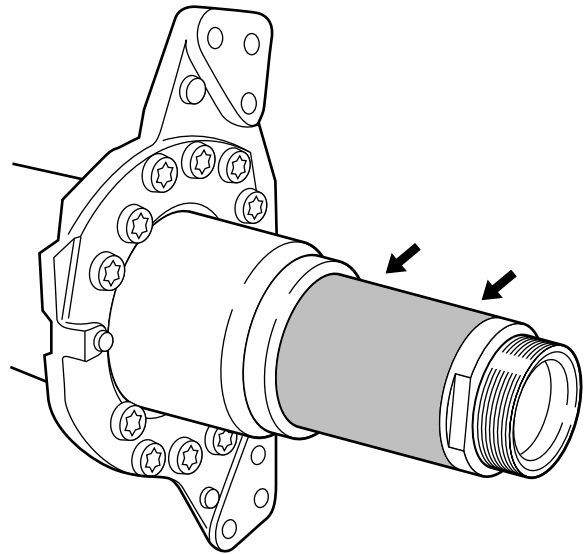

A8 00 344

5. Install the guide sleeve (A), which is part of the special tool set (DAF no. 1329496), on the axle journal.

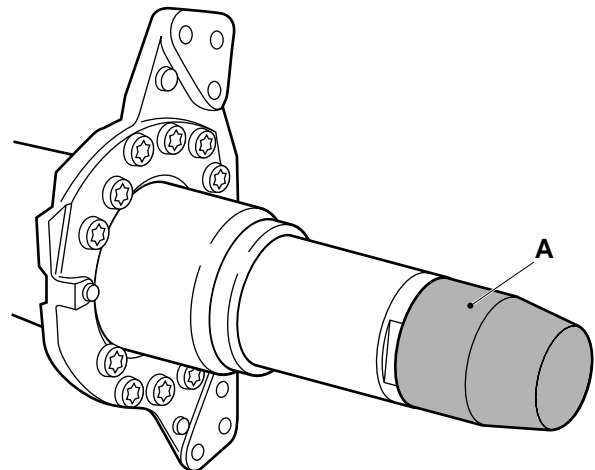

A8 00 343

6. Attach the wheel hub unit (3) securely to a movable lifting device.
7. Position the wheel hub unit (3) exactly in front of the axle journal using the movable lifting device. Slide the wheel hub unit (3) on the axle journal. Take care that the wheel hub unit (3) does not rest on the guide bush as the latter is not strong enough to take the weight of the wheel hub unit (3).
8. Fit the thrust washer (2).
9. Replace the hub nut (1). Apply a few drops of oil to the abutting surface of the hub nut (1). Fit the hub nut (1).

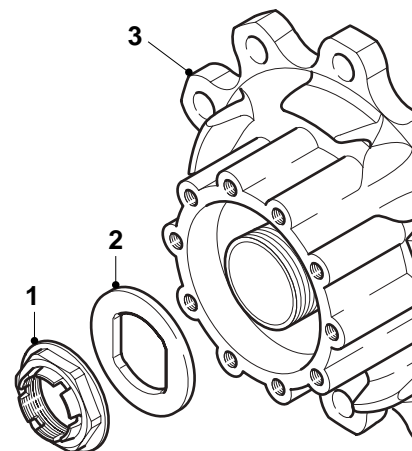

A8 00 356

10. Tighten the hub nut (1) using the hub nut wrench (A), which is part of the special tool set (DAF no. 1329496). Tighten the hub nut (1) in the specified manner using a torque amplifier, see "Technical data".

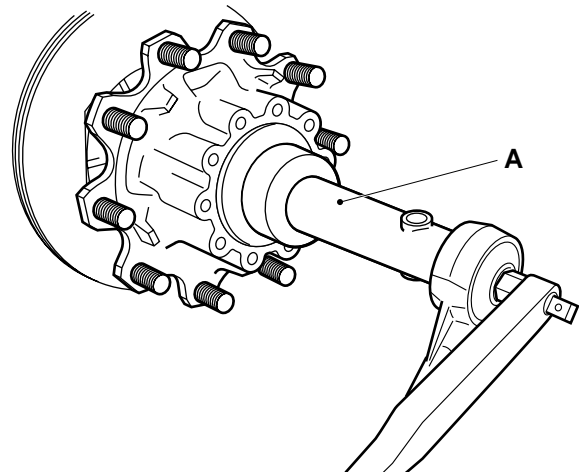

A8 00 405

11. Press the wheel speed sensor (1) up against the sensor ring (2). While the vehicle is being driven, the air gap between the sensor and the sensor ring is adjusted automatically.
12. Fit the axle shaft.
13. Fit the brake calliper.
14. Put the wheels back on.

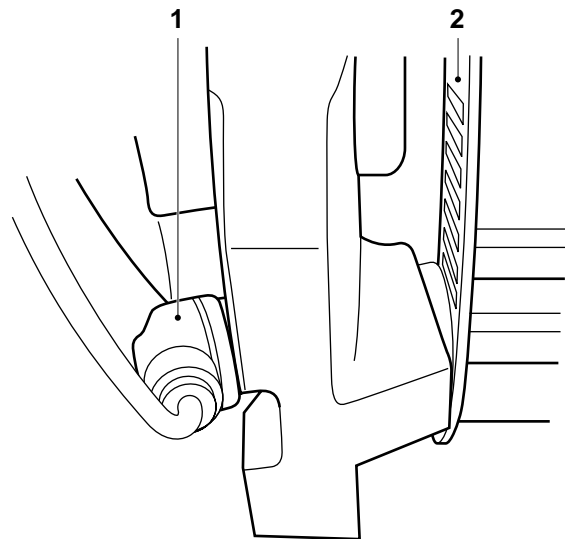

A8 00 342

**3.4 REMOVAL AND INSTALLATION, WHEEL SPEED SENSOR RING**

**Removing the wheel speed sensor ring**

1. Remove the wheel hub unit from the axle journal.
2. Use a driving tool to carefully tap the sensor ring from the inside from the wheel hub unit. Make sure that the wheel hub unit is not damaged in the process.

**3**



**Once removed, a sensor ring should not be re-installed.**

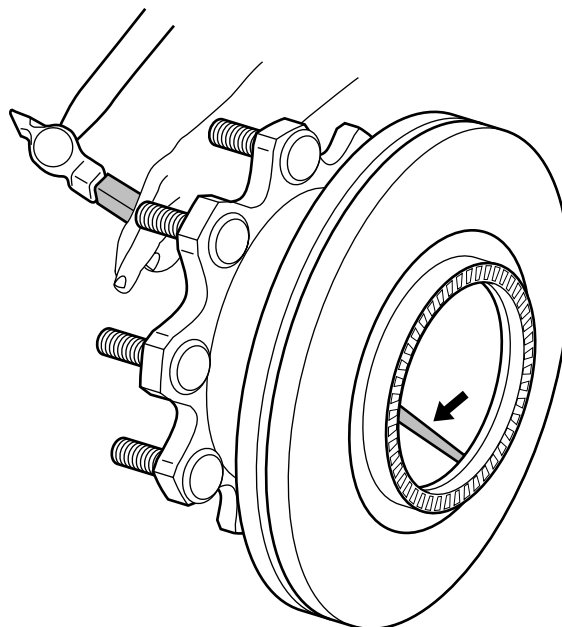

A8 00 359

**Installing the wheel speed sensor ring**

1. Check the mating surfaces of sensor ring and wheel hub unit for damage.
2. Check the new sensor ring carefully for possible damages in transit.
3. Use a flat plate and a press to fit the sensor ring to the wheel hub unit. Press the sensor ring evenly on the wheel hub unit until it fully abuts.
4. Install the wheel hub unit on the axle journal.
5. Press the wheel speed sensor (1) up against the sensor ring (2). While the vehicle is being driven, the air gap between the sensor and the sensor ring is adjusted automatically.

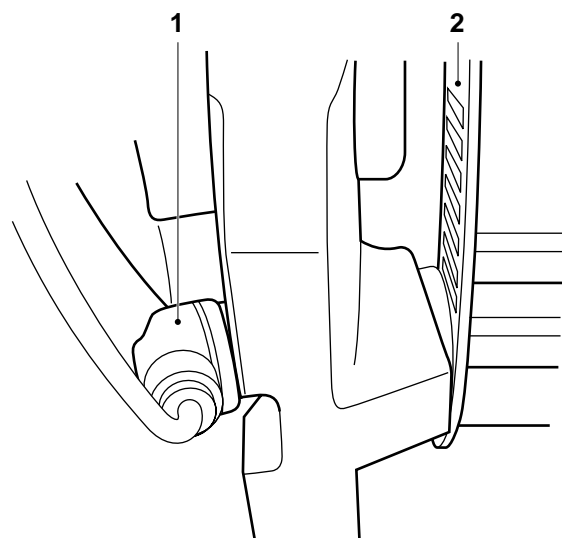

A8 00 342

### 3.5 REMOVAL AND INSTALLATION, DRIVE FLANGE

#### Removing the drive flange

1. Remove the prop shaft from the drive flange.
2. Fit the special tool (B) (DAF no. 0484977) on the drive flange to prevent the flange from rotating. Remove the drive-flange nut using a torque amplifier (A).
3. Remove the drive flange. If necessary, use a puller.

#### Installing the drive flange

1. Before installation check the drive flange along the oil-seal running surface for grooves and/or sharp edges. If required, replace the drive flange.
2. Fit the drive flange.
3. Apply a small amount of grease to the first turn of the drive-flange nut.
4. Apply locking compound to the screw thread. See "Technical data".
5. Fit the special tool (B) (DAF no. 0484977) on the drive flange to prevent the flange from rotating. Fit the drive-flange nut. Use a torque amplifier (A) to tighten the drive-flange nut to the specified tightening torque, see "Technical data".
6. Fit the prop shaft to the drive flange.

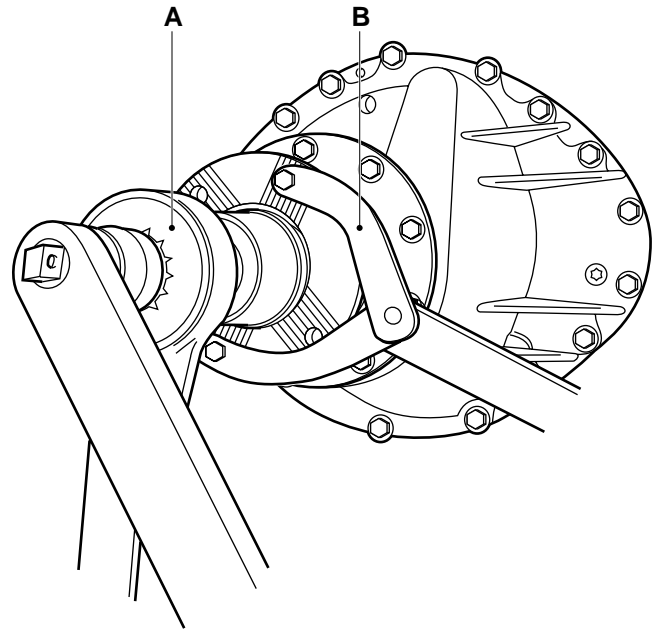

A8 00 357

### 3.6 REMOVAL AND INSTALLATION, PINION OIL SEAL

#### Removing the pinion oil seal

1. Remove the drive flange.
2. Drill two holes into the seal and screw the special tool (B) (DAF no. 0484899) into the seal. Pull the oil seal from the pinion housing using the special tool (A) (DAF no. 0694928).

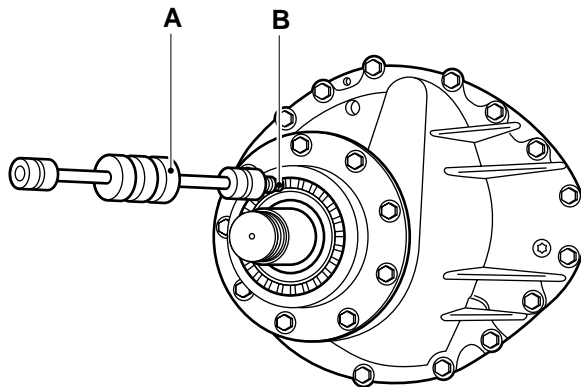

A8 00 360

3

#### Installing the pinion oil seal

1. Use the special tool (DAF no. 1240452) to fit the seal so that the inscription "outside" is pointed outwards.
2. Fit the drive flange.



### 3.7 REMOVAL AND INSTALLATION, DIFFERENTIAL

#### Removing the differential

1. Drain the oil from the differential, see "Draining and filling".
2. Remove the prop shaft from the drive flange.
3. Remove the axle shafts.
4. Remove the air connection for the differential lock.
5. Attach the differential securely to a lifting device.
6. Remove the attachment bolts from the differential.
7. Remove the differential from the axle housing using two jacking screws.

#### Installing the differential

1. Clean the mating surfaces of the axle housing and the differential housing. Re grind the mating faces lightly. Do not damage the mating faces in the process.
2. Clean and degrease the attachment bolts. Apply locking compound to the attachment bolts. See "Technical data".
3. Apply a thin, even layer of sealant to the mating surface and around the bolt holes of the axle housing, see "Technical data".
4. Fit the differential into the axle housing. Install the attachment bolts and tighten them evenly. Tighten the attachment bolts to the specified torque. See "Technical data".
5. Fit the air connection to the differential lock.
6. Fit the axle shafts.
7. Fit the prop shaft to the drive flange.
8. Fill the differential with oil, see "Draining and filling".

3.8 REMOVAL AND INSTALLATION, DIFFERENTIAL LOCK

Removing the differential lock

1. Remove the differential.



**Do not come near the selector sleeve when de-aerating the differential lock.**

2. Pressurise the air connection of the differential lock. Remove the special tool (A). Evenly de-aerate the differential lock.
3. Remove the attachment bolts (1) from the cylinder cover (2). Remove the cover.

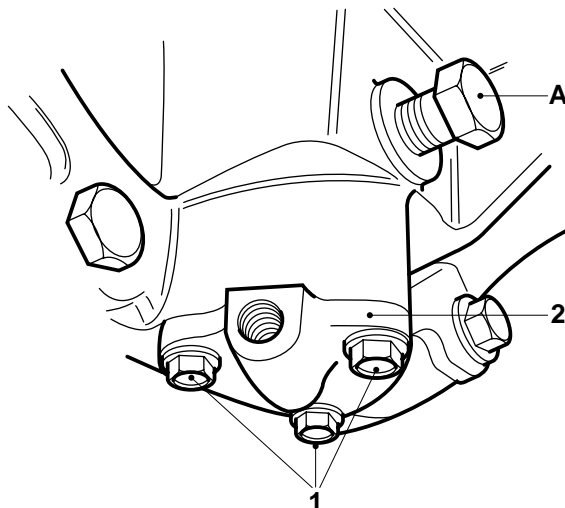

A8 00 353

4. Remove the piston (5).
5. Remove the shifting fork (3) and the sliding sleeve (1) with the spring (2).

Installing the differential lock

1. Fit the shifting fork (3) and the sliding sleeve (1) with the spring (2).

**Note:**

Make sure that the flat side (see arrow) of the shifting fork (3) points towards the piston (5).

2. Apply a small amount of oil to the piston (5) sealing ring (4).
3. Install the piston (5).
4. Install the cylinder cover and tighten the attachment bolts evenly. Tighten the attachment bolts to the specified tightening torque, see "Technical data".

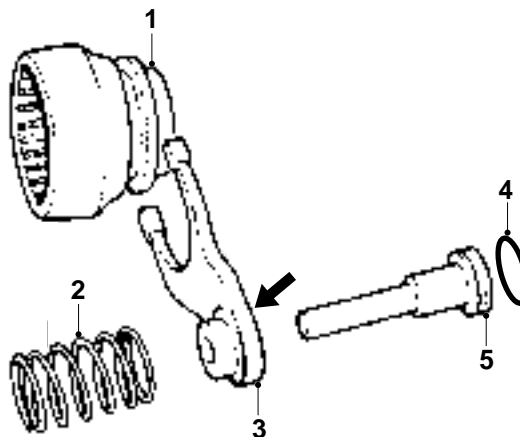

A8 00 354



**Do not come near the selector sleeve when de-aerating the differential lock.**

5. Pressurise the air connection of the differential lock. Fit special tool (A) (DAF no. 1329447), so that the differential lock is blocked.
6. Install the differential.

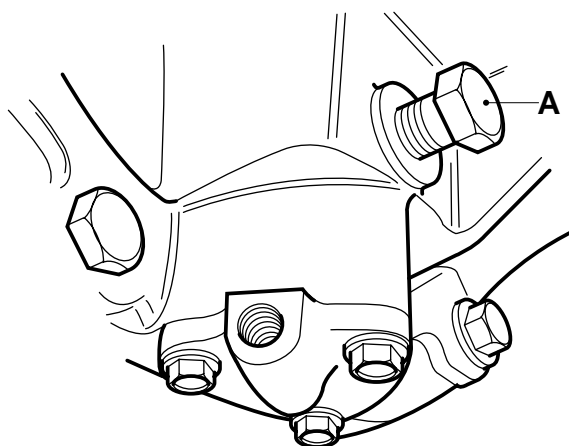

A8 00 346



## 4. DRAINING AND FILLING

### 4.1 DRAINING AND FILLING, DIFFERENTIAL



To prevent skin injury, avoid unnecessary contact with the drained oil.

#### Draining the differential

1. Position the vehicle on a level surface.
2. Remove the level check/filler plug (A) and drain plug (B). Drain the oil.
3. Fit the drain plug (B) using the special Torx wrench (DAF no. 1329493) and tighten to the specified torque; see "Technical data".

#### Filling the differential

1. Fill the differential via the level check/filler plug (A) with the specified quantity of oil, see "Technical data".
2. Check the oil level after approx. 5 minutes. The oil level should now have reached the level check/filler opening. See "Inspection and adjustment".
3. Fit the level check/filler plug (A) using the special Torx wrench (DAF no. 1329493) and tighten to the specified torque; see "Technical data".

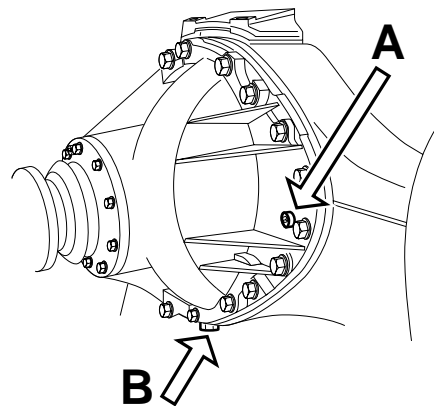

M8013



## CONTENTS

	Page	Date
<b>1. GENERAL</b> .....	1-1	200424
1.1 Description .....	1-1	200424
1.2 Overview drawing, wheel hub unit .....	1-2	200424
<b>2. INSPECTION AND ADJUSTMENT</b> .....	2-1	200424
2.1 Checking the differential oil level .....	2-1	200424
2.2 Checking the operation of the differential lock .....	2-2	200424
2.3 Checking the wheel speed sensor ring .....	2-2	200424
2.4 Inspection and adjustment, caster .....	2-3	200424
<b>3. REMOVAL AND INSTALLATION</b> .....	3-1	200424
3.1 Removal and installation, entire rear axle .....	3-1	200424
3.2 Removal and installation, axle shafts .....	3-2	200424
3.3 Removal and installation, wheel hub unit .....	3-4	200424
3.4 Removal and installation, wheel speed sensor ring .....	3-8	200424
3.5 Removal and installation, drive flange .....	3-9	200424
3.6 Removal and installation, pinion oil seal .....	3-10	200424
3.7 Removal and installation, differential .....	3-11	200424
3.8 Removal and installation, differential lock .....	3-12	200424
<b>4. DRAINING AND FILLING</b> .....	4-1	200424
4.1 Draining and filling, differential .....	4-1	200424





## 1. GENERAL

### 1.1 DESCRIPTION

#### Differential

The differential has a hypoid bevel gear.

A single reduction is applied.

The bevel gear-to-pinion backlash is achieved using adjusting nuts.

The pinion housing can be removed using jacking screws.

The pinion bearing is adjusted using shims which are placed between the inner bearing races.

#### Differential lock

The differential is equipped with a variable differential lock.

The right side of the satellite-gear housing flange is fitted with spline tothing. The left side of the selector sleeve is equipped with similar tothing. The selector sleeve is fitted with splines, similar to the splines in the axle shaft.

The outside of the selector sleeve is fitted with a groove, in which a fork fits which is attached to the engaging cylinder.

If the engaging cylinder is pressurised using a pneumatic switch, the tothing of the selector sleeve will mesh with the tothing of the satellite-gear housing.

If the engaging cylinder is vented via the pneumatic switch, the spring will ensure that the lock is deactivated.

#### Wheel hub unit

The wheel hub, wheel bearings in compact version and hub oil seal form a unit, also called the wheel hub unit (3).

The thrust washer (2) installed between the hub nut (1) and wheel bearing, is fitted with two straight surfaces on the inside to prevent the washer from turning. This is to prevent the hub nut (1) from loosening in case of wheel bearing problems. The hub nut (1) is of the self-locking type. The nut is locked by bending the lips on the hub nut outward.

The wheel bearings of the wheel hub unit are greased and are maintenance free.

The correct wheel bearing pre-load is achieved by installing the hub nut as specified.

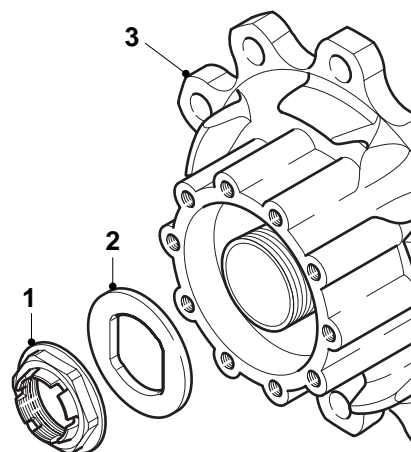

A8 00 356

## 1.2 OVERVIEW DRAWING, WHEEL HUB UNIT

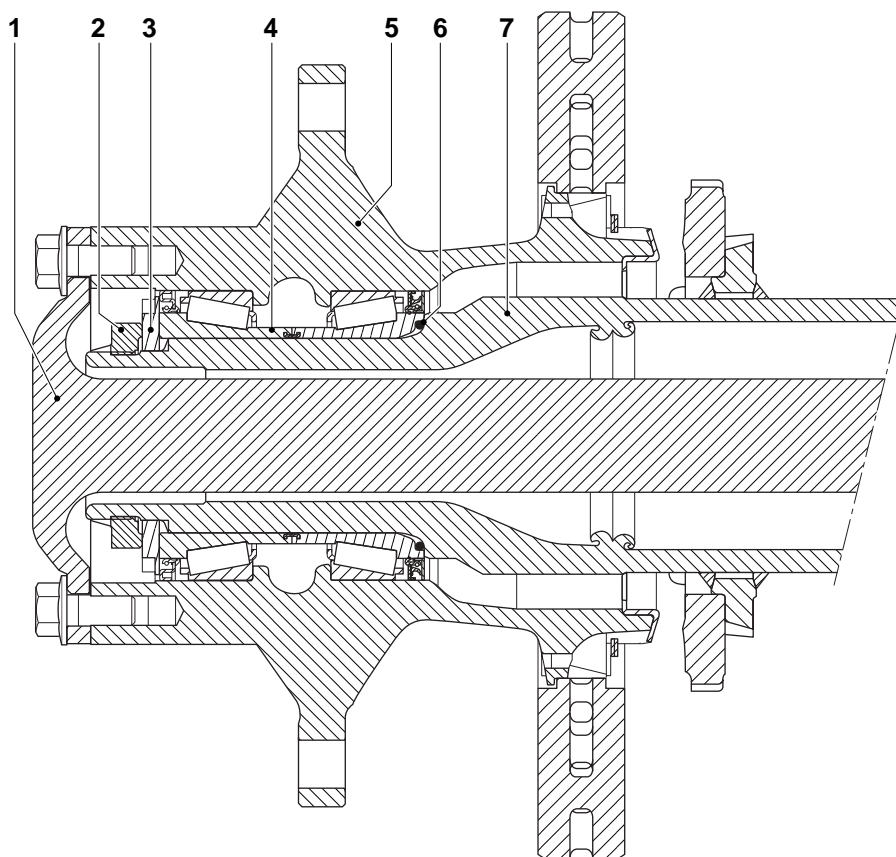

A8 00 341

- 1. Axle shaft
- 2. Hub nut
- 3. Thrust washer
- 4. Compact bearings
- 5. Hub
- 6. O-ring
- 7. Axle journal

4

## 2. INSPECTION AND ADJUSTMENT

### 2.1 CHECKING THE DIFFERENTIAL OIL LEVEL



To prevent skin injury, avoid unnecessary contact with the drained oil.

1. Position the vehicle on a level surface.
2. Lower the trailing axle, if present, on a leaf-sprung version.
3. Remove the oil-level check/filler plug (A). The oil level should reach the level check/filler opening.
4. Fit the plug using the special tool (DAF no. 1329493) and tighten the plug to the specified tightening torque. See "Technical data".

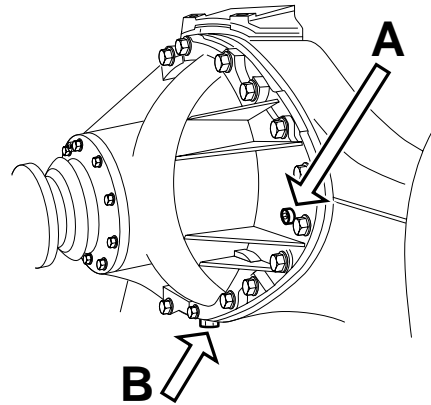

M8013

## 2.2 CHECKING THE OPERATION OF THE DIFFERENTIAL LOCK

1. Jack up the rear axle and support the axle on stands.
2. Bring the air system to operating pressure.
3. Engage the differential lock. The warning lamp should now come on.
4. Check that there is a "rigid" connection between the driven wheels.
5. Disengage the differential lock. The warning lamp should not light up and the "rigid" connection between the driven wheels should be broken.

4

## 2.3 CHECKING THE WHEEL SPEED SENSOR RING

1. Remove the wheel hub unit.
2. Check the sensor ring (2) for deposits. Special attention should be paid to deposits between the teeth of the sensor ring. Clean the sensor ring if necessary.
3. Check the sensor ring (2) for damage. Even the slightest damage can cause a failure. If necessary replace the sensor ring.
4. If possible, the sensor ring (2) should be checked for the maximum admissible axial end play. See "Technical data".
5. Check the sensor (1) for freedom of movement. If necessary, clean the sensor (1) and apply new grease.

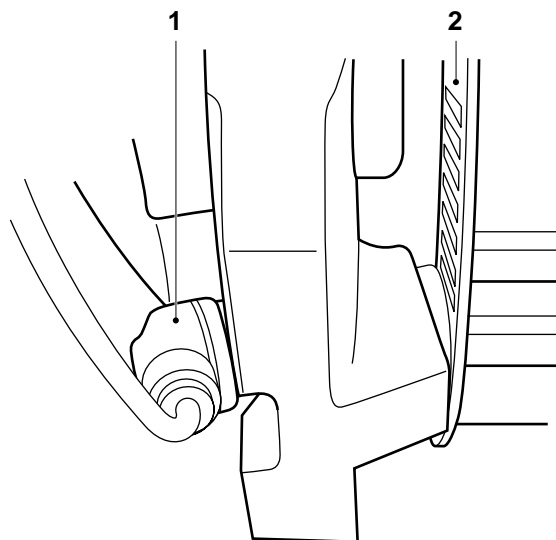

A8 00 342

## 2.4 INSPECTION AND ADJUSTMENT, CASTER

### Checking the caster

1. Place the vehicle on a flat surface.
2. Try to achieve a nominal axle load with the trailing axle on the ground.
3. Remove the prop shaft from the differential.
4. Place an angle gauge on the drive flange and measure the caster of the axle relative to the chassis side member. See "Technical data" for the specified caster.

### Adjusting the caster, leaf-sprung trailing axle

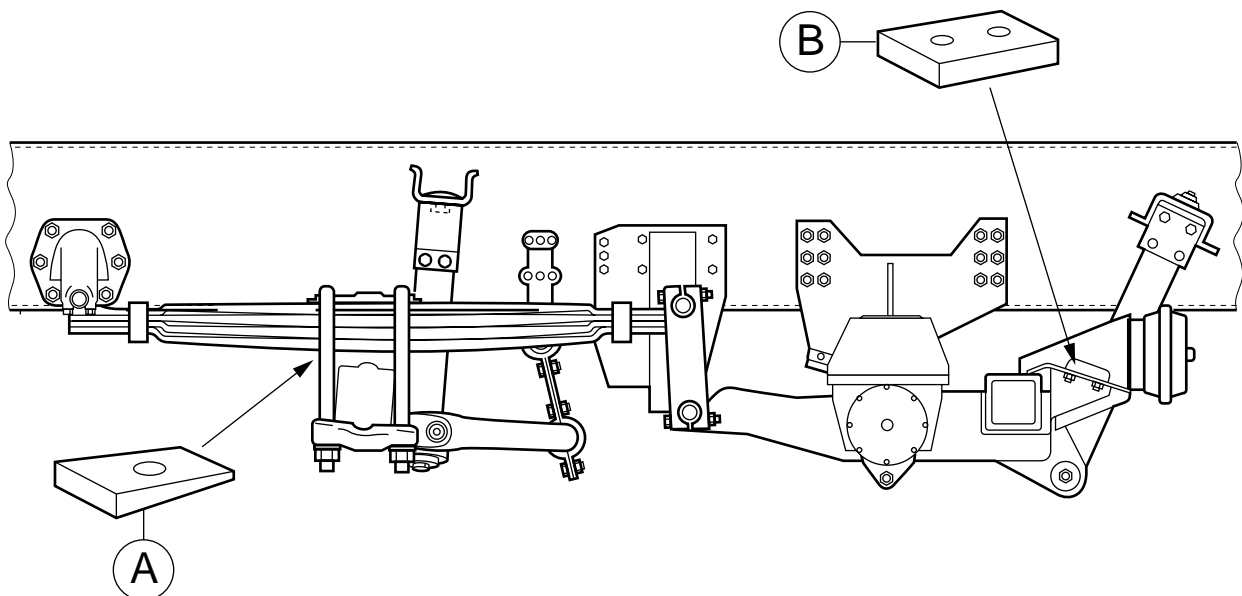

A8 00 292

#### Note:

The lowering of the lifting height of the trailing axle reduces the caster. See "Technical data" for the minimum lifting height of the trailing axle.

1. Fit a block (B) (can be made by yourself) under the stop block.
2. Fit the stop block.
3. If the correction made by this process is insufficient, the caster must be corrected on the driven axle.

### Adjusting the caster, driven axle

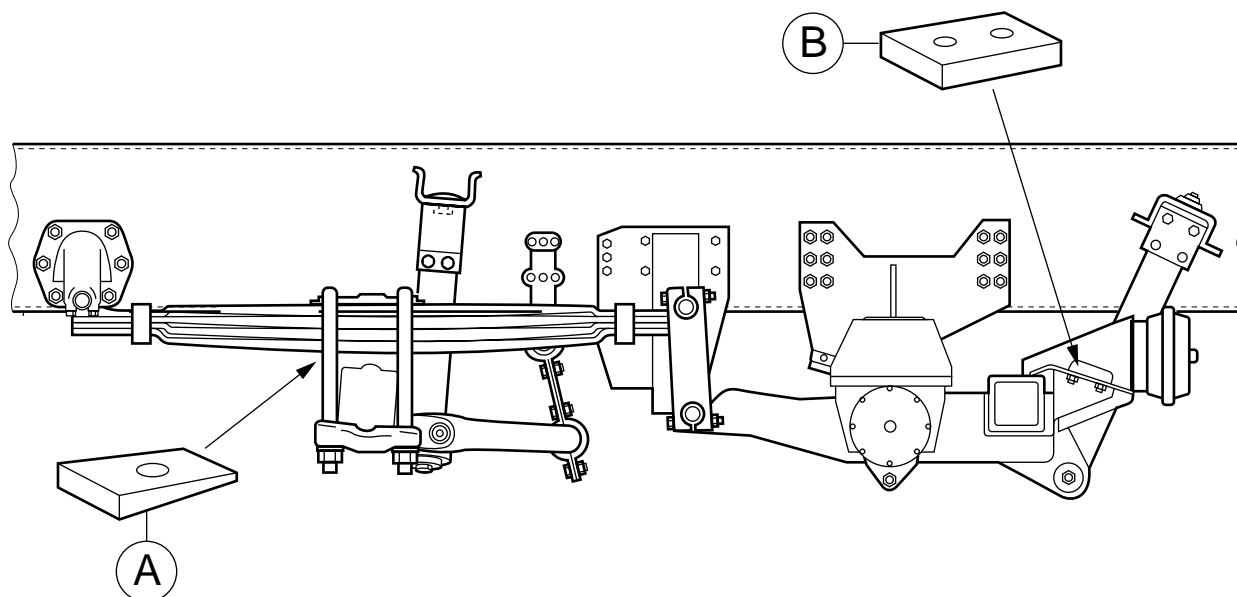

4

1. Jack up the chassis in such a way that the driven axle is free.

A8 00 292

**Note:**

Ensure that both the chassis and axle are well supported with stands.

2. Loosen the U-bolt nuts so that the correct key can be fitted to position (A).
3. Tighten the U-bolt nuts evenly on both sides to the specified torque.
4. Check the caster again.

### 3. REMOVAL AND INSTALLATION

#### 3.1 REMOVAL AND INSTALLATION, ENTIRE REAR AXLE

##### Removing the entire rear axle

1. Block the front wheels using chocks.
2. Slacken the central bolt of the spring-brake cylinder as much as possible.
3. Apply the parking brake.
4. Remove the air pipes and wiring.
5. Remove the prop shaft from the drive flange.
6. Loosen the shock absorbers on the bottom.
7. Support the vehicle securely with stands under the chassis side members.
8. Remove the axle suspension/guide. Take precautionary measures to make sure that the axle does not tilt during removal of the axle suspension/guide.
9. If possible, the entire rear axle with wheels should be rolled from under the vehicle.

##### Installing the entire rear axle

1. Install the entire rear axle with wheels under the vehicle.
2. Fit the axle suspension/guide.
3. Fit the shock absorbers.
4. Fit the prop shaft to the drive flange.
5. Connect the electrical wiring and fit the air pipes.
6. Tighten the central bolt of the spring-brake cylinder.

### 3.2 REMOVAL AND INSTALLATION, AXLE SHAFTS

#### Removing axle shafts

1. Jack up the rear axle and support the axle on stands.
2. Engage the differential lock. Check whether the axle is blocked. Replace the switch by the special tool (DAF no. 1329447), see (A). This is to prevent the sliding sleeve from falling into the differential when removing the axle shaft.

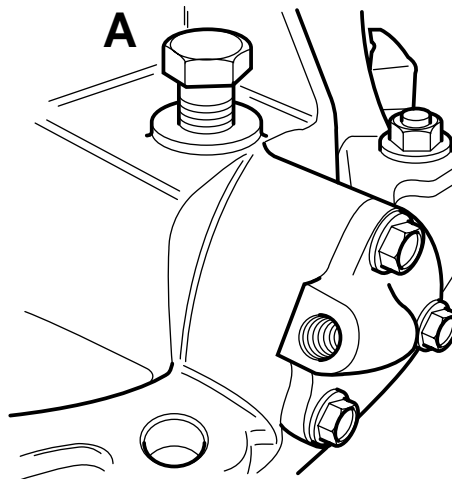

A800139

3. Remove the axle-shaft attachment bolts.
4. Remove the axle shaft using special tool (DAF no. 0694980), if required, see (B). When the axle shaft comes loose, a small amount of oil may leak out. Collect this oil.

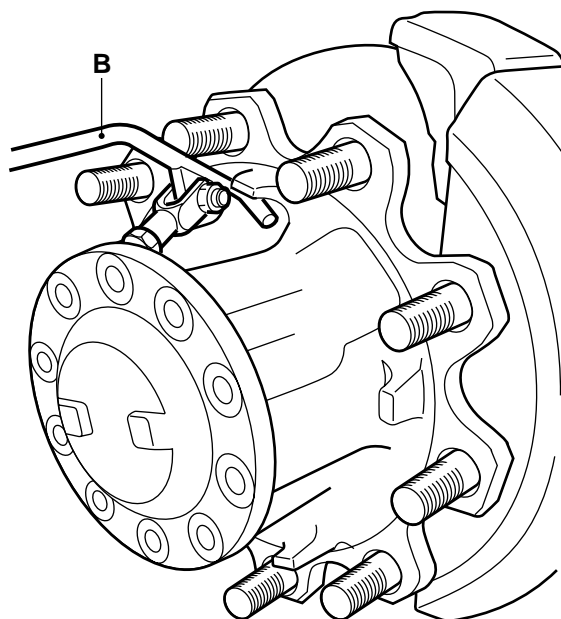

A8 00 351



**Installing axle shafts**

1. Clean the mating surfaces of the axle shaft flange and wheel hub unit.
2. Apply sealant to the mating surface of the axle shaft flange. See "Technical data".
3. Fit the axle shaft. Tighten the axle shaft attachment bolts to the specified tightening torque, see "Technical data".
4. Activate the differential lock and remove the special tool from the differential lock. Install the switch.

**3.3 REMOVAL AND INSTALLATION, WHEEL HUB UNIT**

**4**

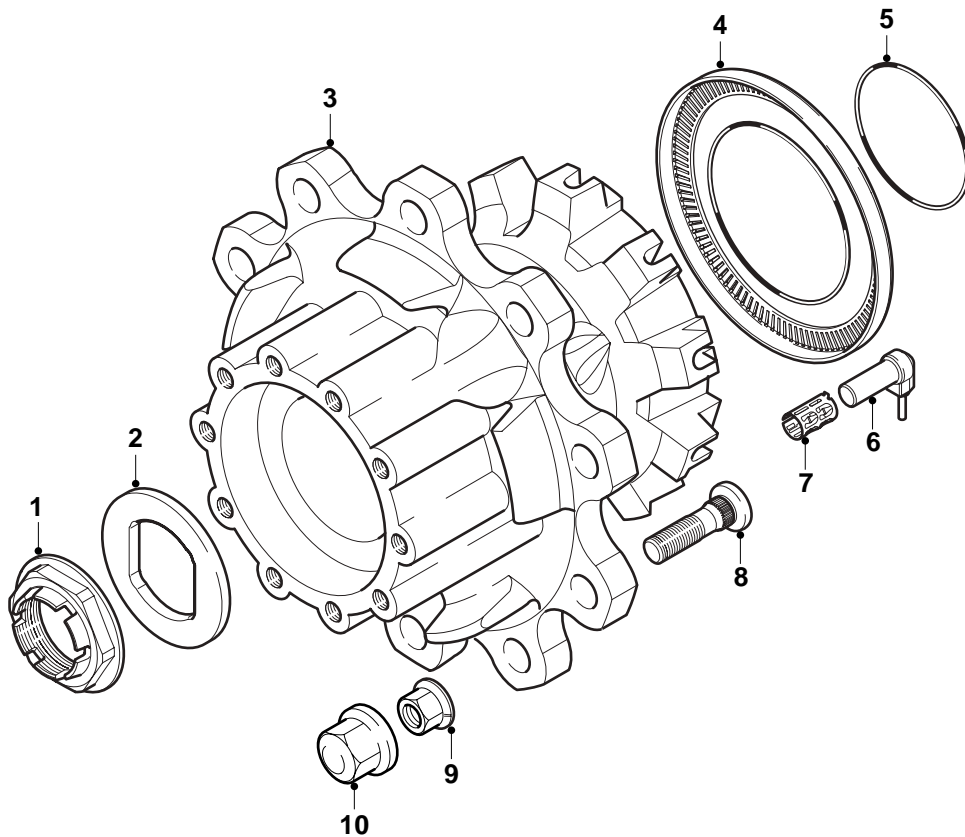

A8 00 348

**Removing the wheel hub unit**

1. Jack up the rear axle and support the axle on stands.
2. Remove the wheels.
3. Remove the brake calliper.
4. Remove the axle shaft.
5. Remove the hub nut (1) using the hub nut wrench (A), which is part of the special tool set (DAF no. 1329496). Loosen the hub nut (1), using a torque amplifier to do so.
6. Remove the thrust washer (2).

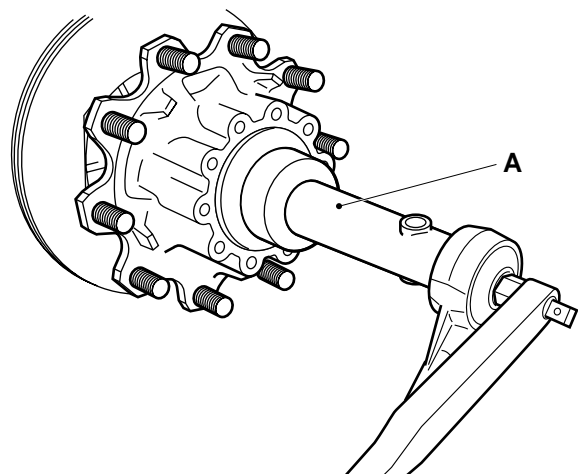

A8 00 405

7. Install the guide sleeve (A), which is part of the special tool set (DAF no. 1329496), on the axle journal.
8. Attach the wheel hub unit (3) securely to a movable lifting device.
9. Slide the wheel hub unit (3) from the axle journal using the lifting device.
10. Take care that the wheel hub unit (3) does not rest on the guide bush (A) as the latter is not strong enough to take the weight of the wheel hub unit (3).

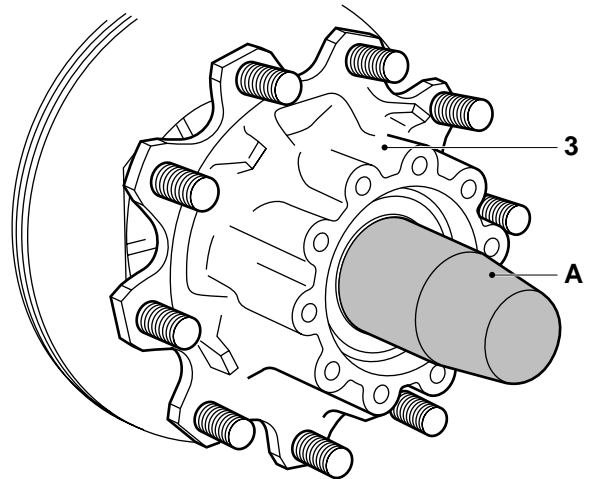

A8 00 345

4

#### Installing the wheel hub

1. Check the wheel speed sensor and the oil seals in the wheel hub unit (3) for damage.
2. Check the axle journal thread carefully for damage.



**You must never fit a wheel hub on an axle journal with a damaged thread.**

3. Fit the O-ring (5) into the wheel hub unit.

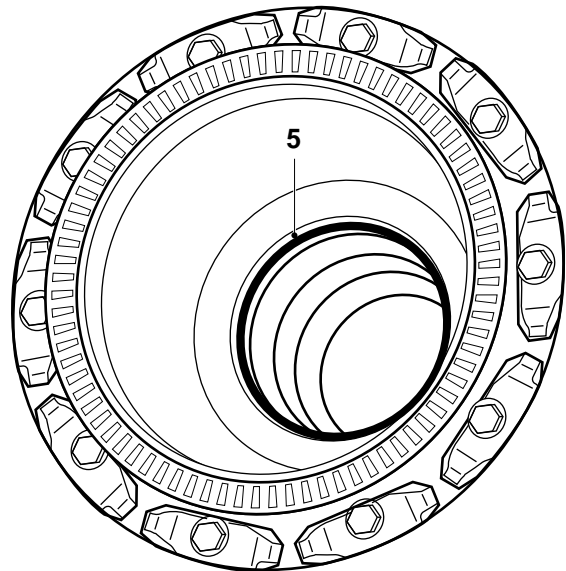

A8 00 350

4. Apply a thin and even layer of the prescribed lubricant to the axle journal, see "Technical data".

**Note:**

Do not overlubricate the axle journal. While fitting the wheel hub unit, the excess grease will collect at the backside of the wheel hub. When the vehicle is used in daily operation, this anti-corrosion agent can leak out so that it looks as if the oil seal leaks.

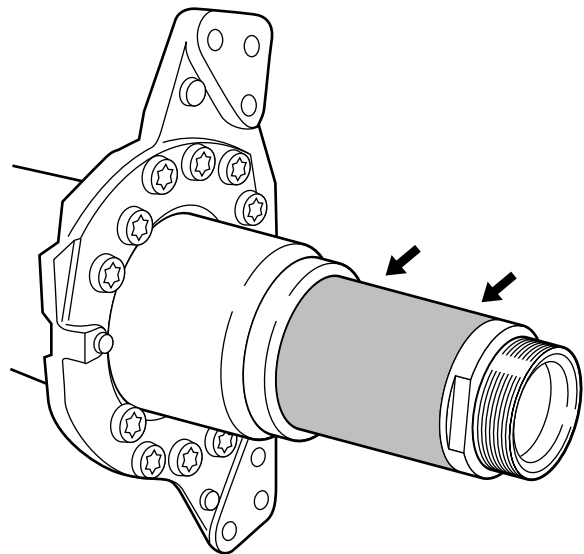

A8 00 344

5. Install the guide sleeve (A), which is part of the special tool set (DAF no. 1329496), on the axle journal.

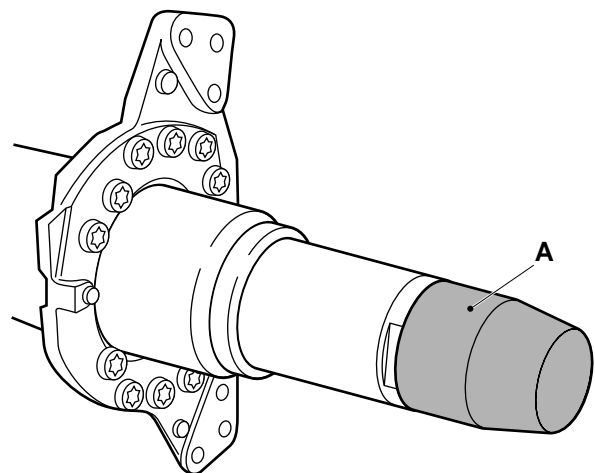

A8 00 343

6. Attach the wheel hub unit (3) securely to a movable lifting device.
7. Position the wheel hub unit (3) exactly in front of the axle journal using the movable lifting device. Slide the wheel hub unit (3) on the axle journal. Take care that the wheel hub unit (3) does not rest on the guide bush as the latter is not strong enough to take the weight of the wheel hub unit (3).
8. Fit the thrust washer (2).
9. Replace the hub nut (1). Apply a few drops of oil to the abutting surface of the hub nut (1). Fit the hub nut (1).

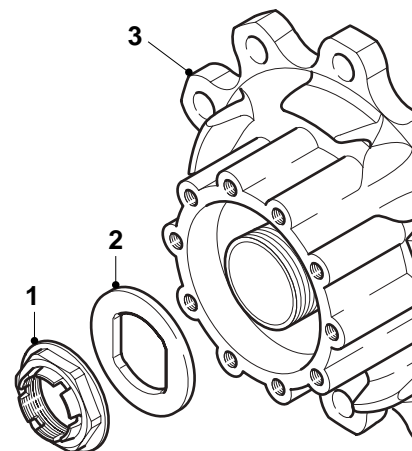

A8 00 356

10. Tighten the hub nut (1) using the hub nut wrench (A), which is part of the special tool set (DAF no. 1329496). Tighten the hub nut (1) in the specified manner using a torque amplifier, see "Technical data".

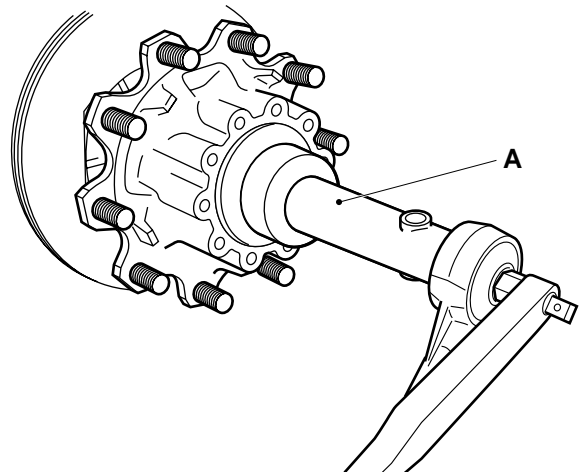

A8 00 405

11. Press the wheel speed sensor (1) up against the sensor ring (2). While the vehicle is being driven, the air gap between the sensor and the sensor ring is adjusted automatically.
12. Fit the axle shaft.
13. Fit the brake calliper.
14. Put the wheels back on.

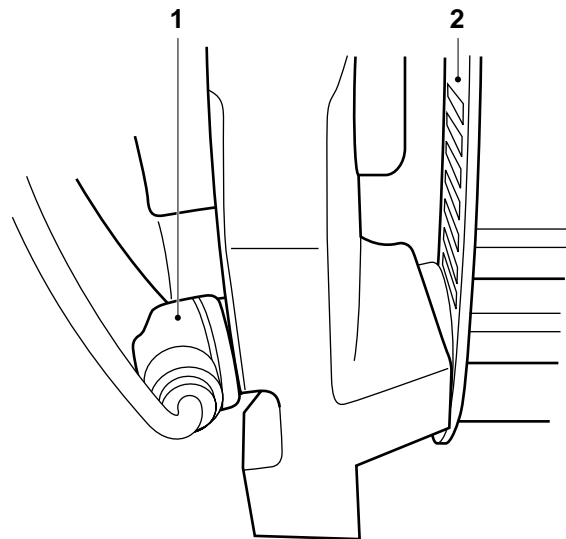

A8 00 342

### 3.4 REMOVAL AND INSTALLATION, WHEEL SPEED SENSOR RING

#### Removing the wheel speed sensor ring

1. Remove the wheel hub unit from the axle journal.
2. Use a driving tool to carefully tap the sensor ring from the inside from the wheel hub unit. Make sure that the wheel hub unit is not damaged in the process.



Once removed, a sensor ring should not be re-installed.

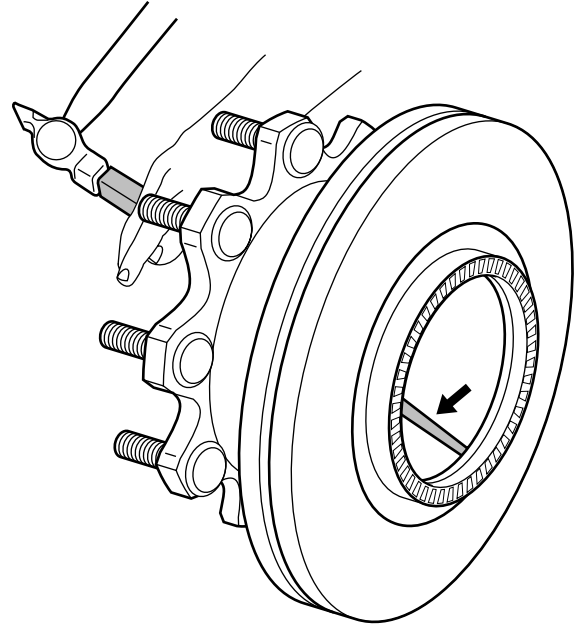

A8 00 359

#### Installing the wheel speed sensor ring

1. Check the mating surfaces of sensor ring and wheel hub unit for damage.
2. Check the new sensor ring carefully for possible damages in transit.
3. Use a flat plate and a press to fit the sensor ring to the wheel hub unit. Press the sensor ring evenly on the wheel hub unit until it fully abuts.
4. Install the wheel hub unit on the axle journal.
5. Press the wheel speed sensor (1) up against the sensor ring (2). While the vehicle is being driven, the air gap between the sensor and the sensor ring is adjusted automatically.

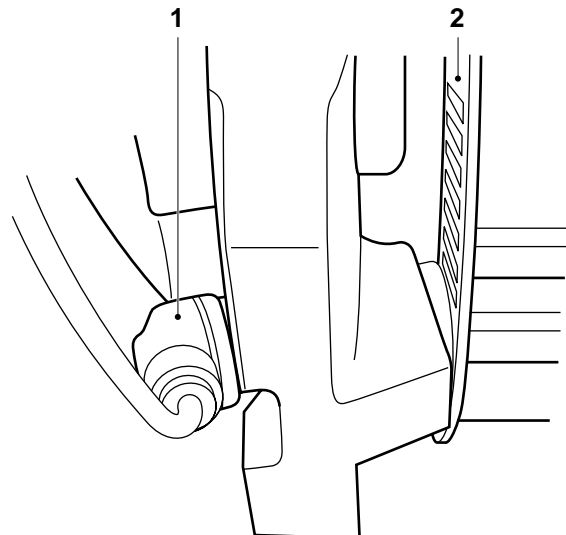

A8 00 342

### 3.5 REMOVAL AND INSTALLATION, DRIVE FLANGE

#### Removing the drive flange

1. Remove the prop shaft from the drive flange.
2. Fit the special tool (B) (DAF no. 0484977) on the drive flange to prevent the flange from rotating. Remove the drive-flange nut using a torque amplifier (A).
3. Remove the drive flange. If necessary, use a puller.

#### Installing the drive flange

1. Before installation check the drive flange along the oil-seal running surface for grooves and/or sharp edges. If required, replace the drive flange.
2. Fit the drive flange.
3. Apply a small amount of grease to the first turn of the drive-flange nut.
4. Apply locking compound to the screw thread. See "Technical data".
5. Fit the special tool (B) (DAF no. 0484977) on the drive flange to prevent the flange from rotating. Fit the drive-flange nut. Use a torque amplifier (A) to tighten the drive-flange nut to the specified tightening torque, see "Technical data".
6. Fit the prop shaft to the drive flange.

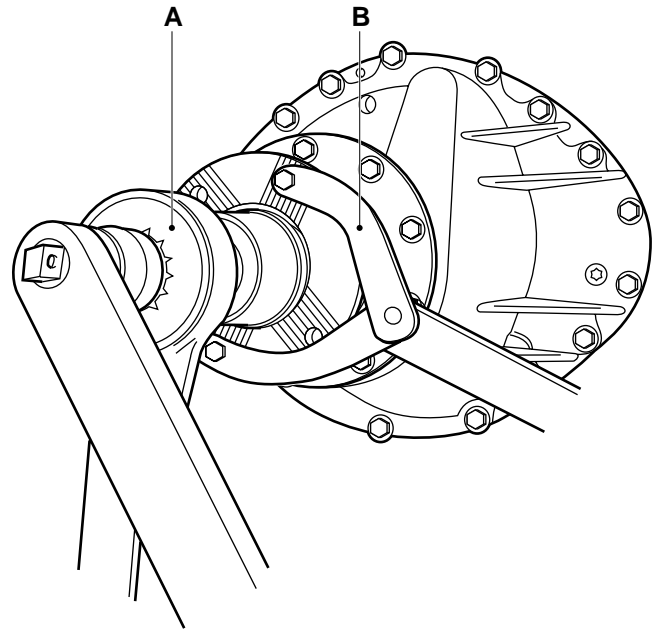

A8 00 357

### 3.6 REMOVAL AND INSTALLATION, PINION OIL SEAL

#### Removing the pinion oil seal

1. Remove the drive flange.
2. Drill two holes into the seal and screw the special tool (B) (DAF no. 0484899) into the seal. Pull the oil seal from the pinion housing using the special tool (A) (DAF no. 0694928).

#### Installing the pinion oil seal

1. Use the special tool (DAF no. 1240452) to fit the seal so that the inscription "outside" is pointed outwards.
2. Fit the drive flange.

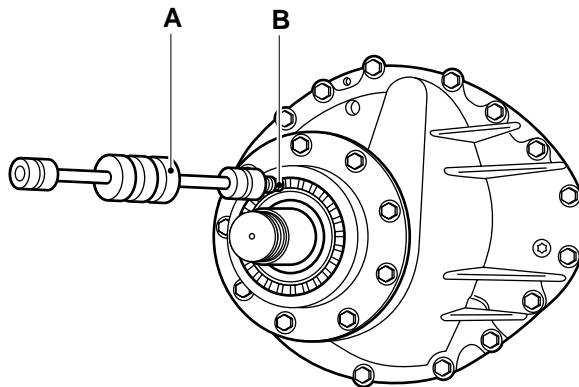

A8 00 360



### 3.7 REMOVAL AND INSTALLATION, DIFFERENTIAL

#### Removing the differential

1. Drain the oil from the differential, see "Draining and filling".
2. Remove the prop shaft from the drive flange.
3. Remove the axle shafts.
4. Remove the air connection for the differential lock.
5. Attach the differential securely to a lifting device.
6. Remove the attachment bolts from the differential.
7. Remove the differential from the axle housing using two jacking screws.

#### Installing the differential

1. Clean the mating surfaces of the axle housing and the differential housing. Re grind the mating faces lightly. Do not damage the mating faces in the process.
2. Clean and degrease the attachment bolts. Apply locking compound to the attachment bolts. See "Technical data".
3. Apply a thin, even layer of sealant to the mating surface and around the bolt holes of the axle housing, see "Technical data".
4. Fit the differential into the axle housing. Install the attachment bolts and tighten them evenly. Tighten the attachment bolts to the specified torque. See "Technical data".
5. Fit the air connection to the differential lock.
6. Fit the axle shafts.
7. Fit the prop shaft to the drive flange.
8. Fill the differential with oil, see "Draining and filling".

**3.8 REMOVAL AND INSTALLATION, DIFFERENTIAL LOCK**

**Removing the differential lock**

1. Remove the differential.



**Do not come near the selector sleeve when de-aerating the differential lock.**

2. Pressurise the air connection of the differential lock. Remove the special tool (A). Evenly de-aerate the differential lock.
3. Remove the attachment bolts (1) from the cylinder cover (2). Remove the cover.

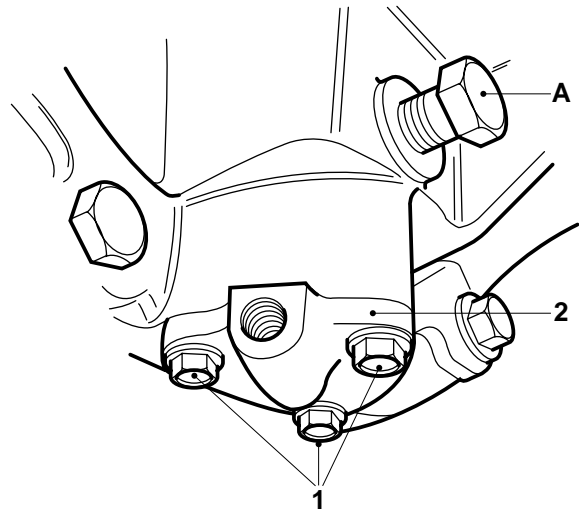

A8 00 353

4. Remove the piston (5).
5. Remove the shifting fork (3) and the sliding sleeve (1) with the spring (2).

**Installing the differential lock**

1. Fit the shifting fork (3) and the sliding sleeve (1) with the spring (2).

**Note:**

Make sure that the flat side (see arrow) of the shifting fork (3) points towards the piston (5).

2. Apply a small amount of oil to the piston (5) sealing ring (4).
3. Install the piston (5).
4. Install the cylinder cover and tighten the attachment bolts evenly. Tighten the attachment bolts to the specified tightening torque, see "Technical data".

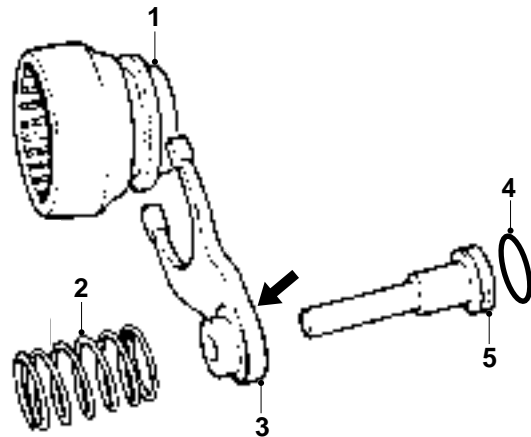

A8 00 354



**Do not come near the selector sleeve when de-aerating the differential lock.**

5. Pressurise the air connection of the differential lock. Fit special tool (A) (DAF no. 1329447), so that the differential lock is blocked.
6. Install the differential.

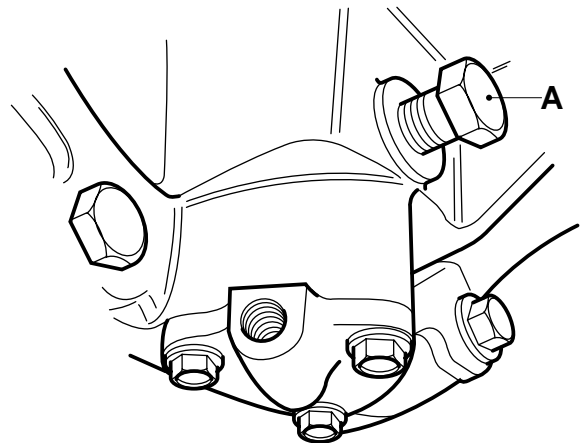

A8 00 346



## 4. DRAINING AND FILLING

### 4.1 DRAINING AND FILLING, DIFFERENTIAL



To prevent skin injury, avoid unnecessary contact with the drained oil.

#### Draining the differential

1. Position the vehicle on a level surface.
2. Remove the level check/filler plug (A) and drain plug (B). Drain the oil.
3. Fit the drain plug (B) using the special Torx wrench (DAF no. 1329493) and tighten to the specified torque; see "Technical data".

#### Filling the differential

1. Fill the differential via the level check/filler plug (A) with the specified quantity of oil, see "Technical data".
2. Check the oil level after approx. 5 minutes. The oil level should now have reached the level check/filler opening. See "Inspection and adjustment".
3. Fit the level check/filler plug (A) using the special Torx wrench (DAF no. 1329493) and tighten to the specified torque; see "Technical data".

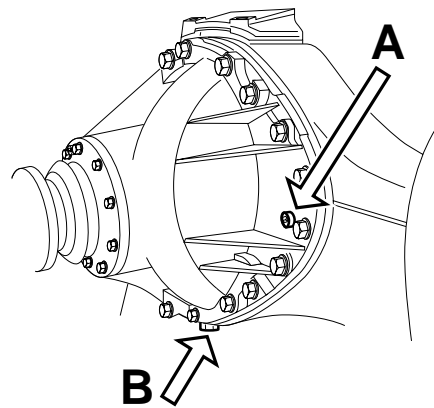

M8013



## CONTENTS

	Page	Date
<b>1. GENERAL</b> .....	1-1	200424
1.1 Description .....	1-1	200424
1.2 Overview drawing, wheel hub .....	1-3	200424
<b>2. INSPECTION AND ADJUSTMENT</b> .....	2-1	200424
2.1 Inspection and adjustment, wheel bearing play .....	2-1	200424
2.2 Checking the hub oil levels .....	2-2	200424
2.3 Checking the differential oil level .....	2-2	200424
2.4 Checking the operation of the differential lock .....	2-3	200424
2.5 Checking the hub and wheel bearings .....	2-3	200424
2.6 Checking the wheel speed sensor ring .....	2-4	200424
2.7 Inspection and adjustment, caster .....	2-5	200424
<b>3. REMOVAL AND INSTALLATION</b> .....	3-1	200424
3.1 Removal and installation, entire rear axle .....	3-1	200424
3.2 Removal and installation, axle shafts .....	3-2	200424
3.3 Removal and installation, wheel hub .....	3-3	200424
3.4 Removal and installation, hub seal/wheel speed sensor ring unit .....	3-6	200424
3.5 Removal and installation, wheel bearings .....	3-9	200424
3.6 Removal and installation, drive flange .....	3-10	200424
3.7 Removal and installation, pinion oil seal .....	3-11	200424
3.8 Removal and installation, differential .....	3-12	200424
3.9 Removal and installation, differential lock .....	3-14	200424
<b>4. DRAINING AND FILLING</b> .....	4-1	200424
4.1 Draining and filling, hub .....	4-1	200424
4.2 Draining and filling, differential .....	4-3	200424





## 1. GENERAL

### 1.1 DESCRIPTION

The reduction in the differential is only very limited. That is why a single-reduction differential can be applied with a pinion which has a relatively large diameter, creating a relatively favourable load.

The load for the satellite gears, planet gear and axle shafts is low.

Due to this low load the crown wheel and pinion could be equipped with a helical toothing instead of a hypoid bevelled gear.

The fitting dimension of the pinion is adjusted using shims, the bevel gear-to-pinion backlash is adjusted using adjusting nuts.

The pinion is supported on two bevel roller bearings. The bearing pre-load of the bevel roller bearings is adjusted using spacers which are positioned between the inner bearing race of the front bevel roller bearing and the shoulder of the pinion.

The satellite-gear housing is supported on bevel roller bearings.

The pre-load of these bearings is adjusted using adjusting nuts.

**Differential lock**

The differential is equipped with a variable differential lock.

The satellite-gear housing flange is fitted with radial tothing at the right. The left side of the selector sleeve is equipped with similar tothing. This selector sleeve is also equipped with keyways which fit into the keyways in the right axle shaft. The left axle-shaft journal is also equipped with keyways which fit into the internal keyways of the planet wheel. The selector sleeve (9) can be slid over the axle shaft using a fork (6). This hinged fork is suspended from the axle (5) fitted to the axle housing. The fork is operated via the control rod which is activated by the engaging cylinder (1). The connection between fork and selector sleeve is composed of two sliding blocks (7) which fit into a groove of the selector sleeve (9). A spring clip ensures that the selector sleeve and sliding blocks do not fall into the axle housing, once the right axle shaft has been removed. Air is admitted to and bled from the engaging cylinder via a pneumatic valve which is operated by a switch on the dashboard.

Once the engaging cylinder is pressurised, the selector sleeve will move to the left.

Subsequently the tothing of the selector sleeve will engage the tothing of the satellite-gear housing.

This will create a rigid connection from the satellite-gear housing via the selector sleeve to the right axle shaft. As a consequence, the remaining parts of the differential, such as the planet wheels and satellite gears, can no longer turn in relation to the satellite-gear housing. The differential is now locked and both the left and the right axle shafts are loaded with 50% of the torque. If the engaging cylinder is bled using the pneumatic switch on the dashboard, a spring in the engaging cylinder will deactivate the lock.

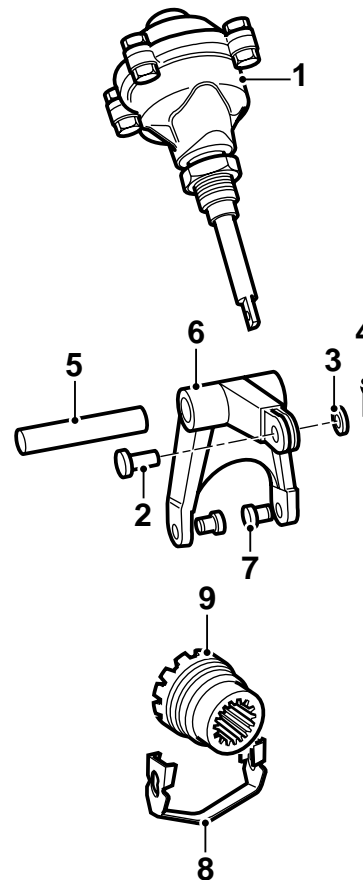

A800021

1.2 OVERVIEW DRAWING, WHEEL HUB

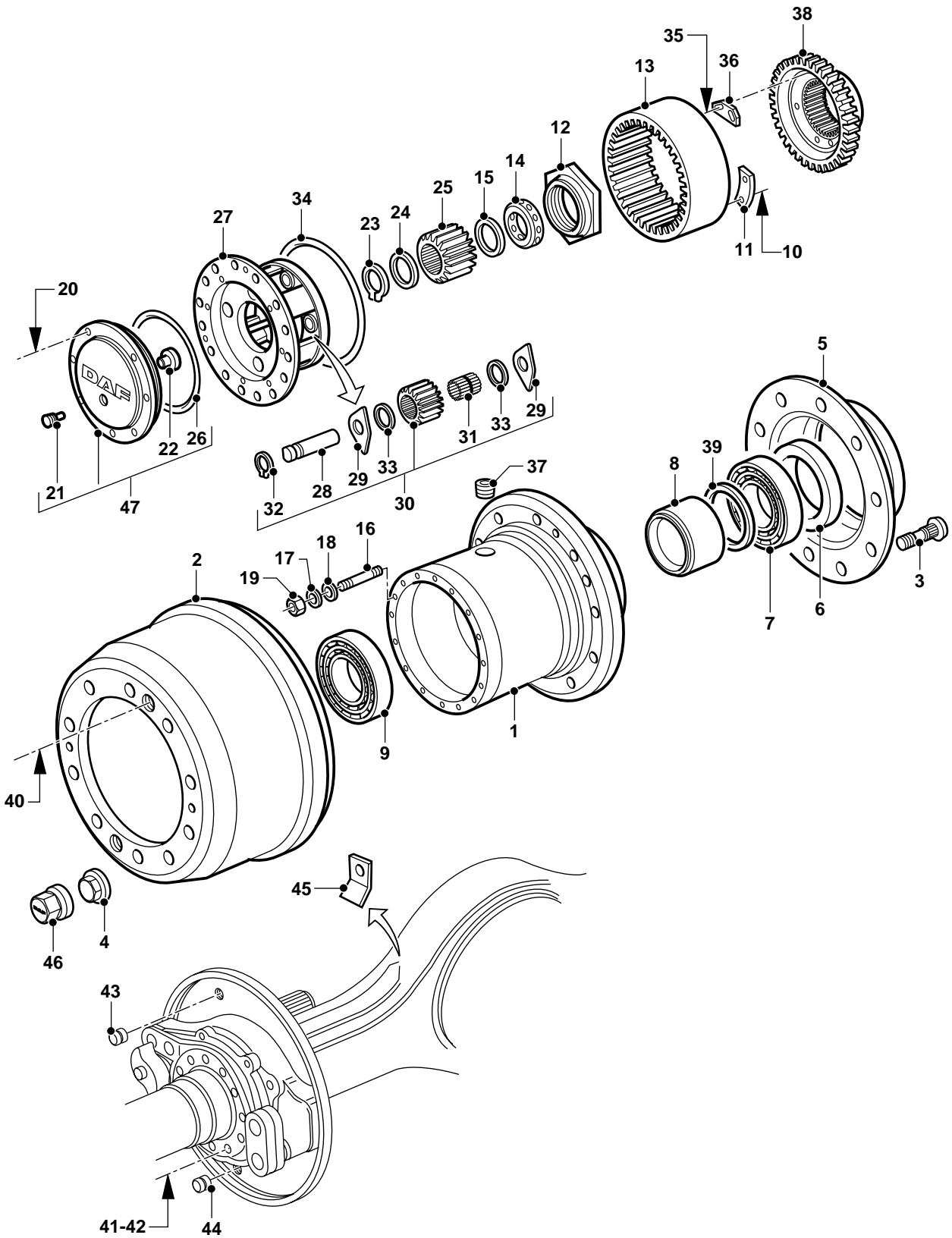

5

A8 00 349

1. Hub
2. Brake drum
3. Wheel stud
4. Nut
5. Grease retainer
6. Oil seal
7. Taper roller bearing
8. Spacer sleeve
9. Taper roller bearing
10. Flange bolt
11. Attachment plate
12. Hub nut
13. Annular gear
14. Thrust washer
15. Ring
16. Stud bolt
17. Spring washer
18. Sealing ring
19. Nut
20. Cap screw
21. Magnet plug
22. Yoke pin
23. Circlip
24. Ring
25. Gear wheel
26. O-ring
27. Planet-gear carrier
28. Shaft
29. Shim
30. Planet wheel
31. Needle bearing
32. Circlip
33. Shim
34. O-ring
35. Flange bolt
36. Locking plate
37. Plug
38. Annular-gear carrier
39. Spacer ring
40. Cap screw
41. Flange bolt
42. Flange nut
43. Grommet
44. Grommet
45. Bracket
46. Cap
47. Hub cap
48. Cover

## 2. INSPECTION AND ADJUSTMENT

### 2.1 INSPECTION AND ADJUSTMENT, WHEEL BEARING PLAY

1. Remove the wheel hub. See "Removal and installation".
2. Remove the hub seal. See "Removal and installation".
3. Fit the wheel hub without the hub seal. See "Removal and installation".
4. Turn a rope several times around the hub and attach it to a wheel stud. Pull the rope using a tensioner gauge and read off the force required to turn the hub at a constant speed. Compare the pressure reading with the technical data. See "Technical data".
5. The pre-load of the wheel bearings can be changed by removing or fitting spacers between the spacer sleeve and the inner wheel bearing. See "Removal and installation".

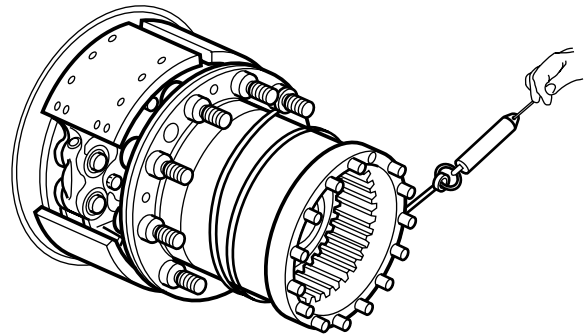

A800039

**2.2 CHECKING THE HUB OIL LEVELS**



**To prevent skin injury, avoid unnecessary contact with the drained oil.**

1. Position the vehicle on a level surface.
2. Position the wheels so that the arrow on the hub is pointing upwards.
3. Remove the level check plug (A). The oil level should have reached the opening.
4. Fit the drain plug (B) using the special Torx wrench (DAF no. 1329493) and tighten to the specified torque; see "Technical data".

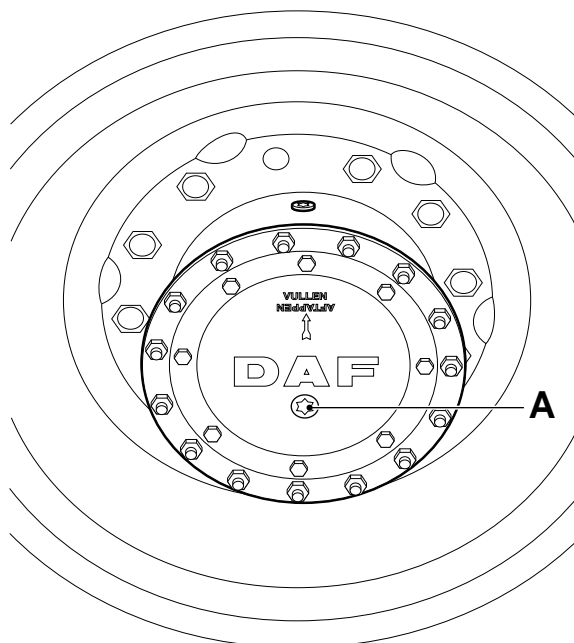

A8 00 365

**5**

**2.3 CHECKING THE DIFFERENTIAL OIL LEVEL**



**To prevent skin injury, avoid unnecessary contact with the drained oil.**

1. Position the vehicle on a level surface.
2. Lower the trailing axle, if present, on a leaf-sprung version.
3. Remove the level check/filler plug (A). The oil level should have reached the level check/filler opening.
4. Fit the drain plug (B) using the special Torx wrench (DAF no. 1329493) and tighten to the specified torque; see "Technical data".

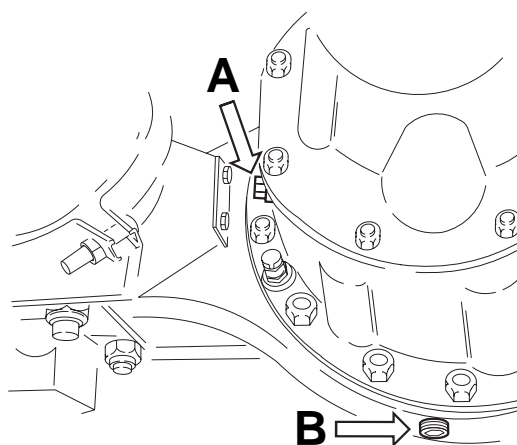

M8048

## 2.4 CHECKING THE OPERATION OF THE DIFFERENTIAL LOCK

1. Jack up the rear axle and support the axle on stands.
2. Bring the air system to operating pressure.
3. Engage the differential lock. The warning lamp should now come on.
4. Check that there is a "rigid" connection between the driven wheels.
5. Disengage the differential lock. The warning lamp should not light up and the "rigid" connection between the driven wheels should be broken.

## 2.5 CHECKING THE HUB AND WHEEL BEARINGS

1. Inspect the bearings for damage at the following points:
  - the roller bearing race,
  - the bearing cage,
  - the raceways of the inner and outer race.If damage is found, the entire bearing (inner race/bearing cage and outer race) should be replaced.
2. If the outer race of the bearing is loose in the hub or has turned in the hub, the hub should be replaced.
3. Check the axle journal screw thread, the bearing surfaces of the inner bearing races and the running surface of the seal for damage.
4. Check the wheel speed sensor ring for damage. Replace the ring at even the slightest trace of damage.

## 2.6 CHECKING THE WHEEL SPEED SENSOR RING

1. Remove the wheel hub. See "Removal and installation".
2. Check the sensor ring (1) for deposits. Special attention should be paid to deposits between the teeth of the sensor ring. Clean the sensor ring if necessary.
3. Check the sensor ring (1) for damage. Even the slightest damage can cause a failure. If necessary replace the sensor ring.
4. If possible, the sensor ring (1) should be checked for the maximum admissible axial end play. See "Technical data".
5. Check the sensor (2) for freedom of movement. If necessary, clean the sensor and apply new grease.

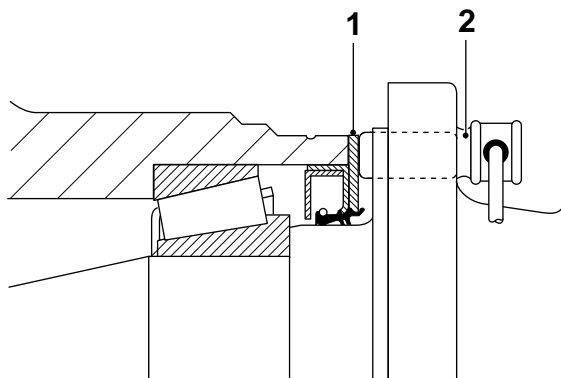

A8 00 347



## 2.7 INSPECTION AND ADJUSTMENT, CASTER

### Checking the caster

1. Place the vehicle on a flat surface.
2. Try to achieve a nominal axle load with the trailing axle on the ground.
3. Remove the prop shaft from the differential.
4. Place an angle gauge on the drive flange and measure the caster of the axle relative to the chassis side member. See "Technical data" for the specified caster.

### Adjusting the caster, leaf-sprung trailing axle

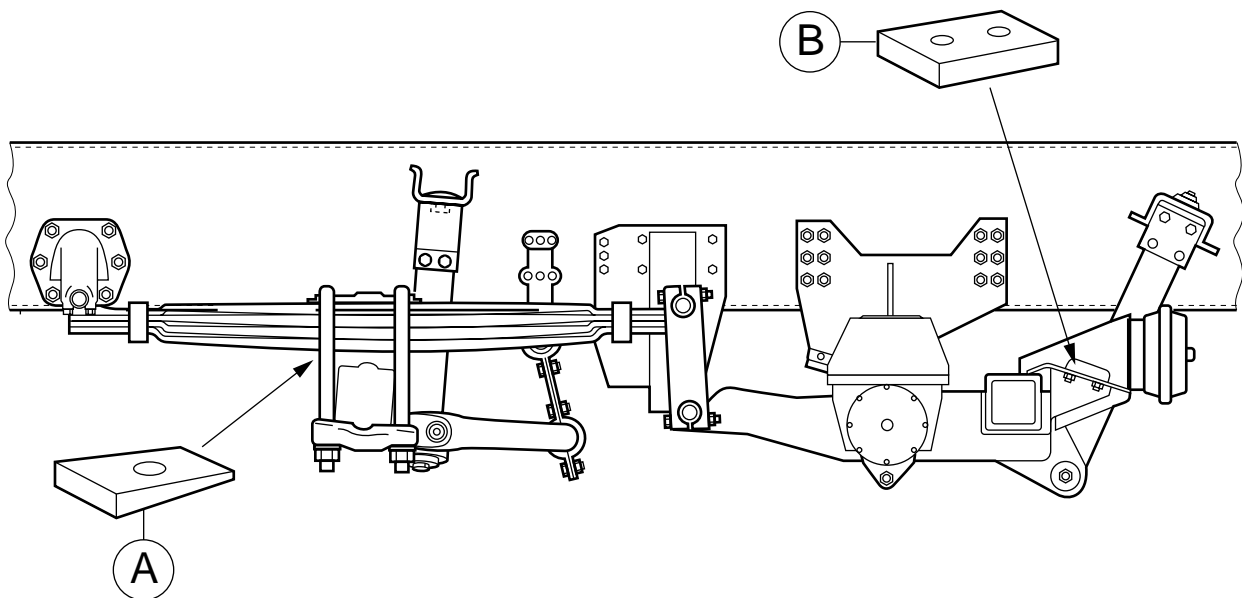

A8 00 292

#### Note:

The lowering of the lifting height of the trailing axle reduces the caster. See "Technical data" for the minimum lifting height of the trailing axle.

1. Fit a block (B) (can be made by yourself) under the stop block.
2. Fit the stop block.
3. If the correction made by this process is insufficient, the caster must be corrected on the driven axle.

**Adjusting the caster, driven axle**

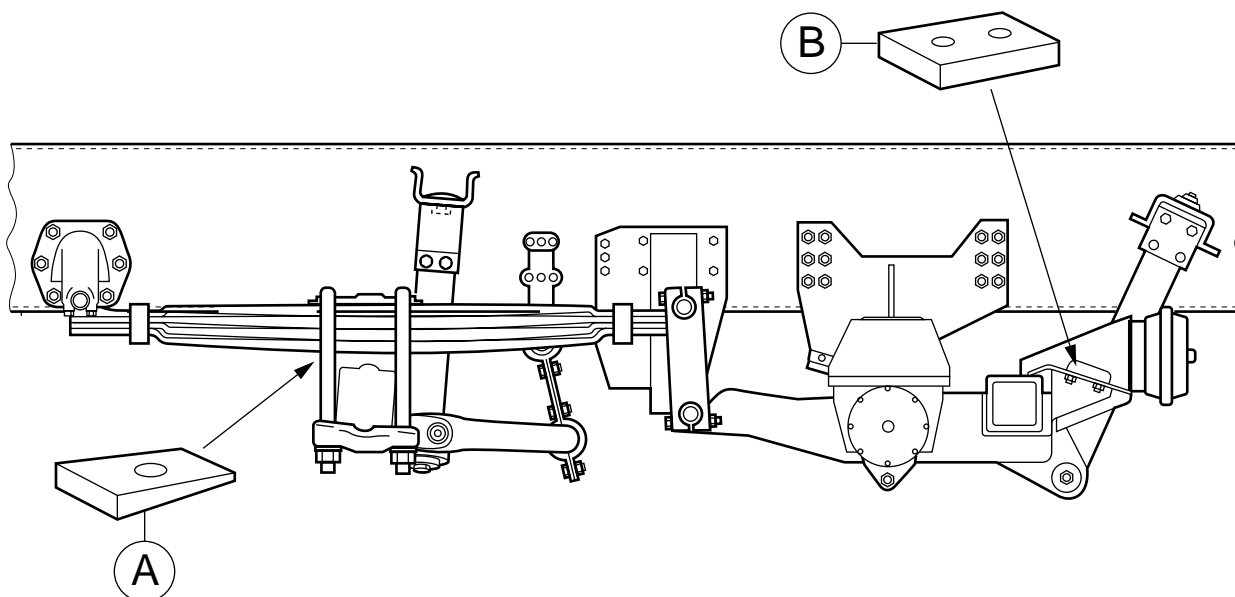

**5**

A8 00 292

1. Jack up the chassis in such a way that the driven axle is free.

**Note:**

Ensure that both the chassis and axle are well supported with stands.

2. Loosen the U-bolt nuts so that the correct key can be fitted to position (A).
3. Tighten the U-bolt nuts evenly on both sides to the specified torque.
4. Check the caster again.

### 3. REMOVAL AND INSTALLATION

#### 3.1 REMOVAL AND INSTALLATION, ENTIRE REAR AXLE

##### Removing the entire rear axle

1. Block the front wheels using chocks.
2. Slacken the central bolt of the spring-brake cylinder as much as possible.
3. Apply the parking brake.
4. Remove the air pipes and wiring.
5. Remove the prop shaft from the drive flange.
6. Loosen the shock absorbers on the bottom.
7. Loosen the control rod of the ALR valve.
8. Support the vehicle securely with stands under the chassis side members.
9. Remove the axle suspension/guide.  
Take precautionary measures to make sure that the axle does not tilt during removal of the axle suspension/guide.
10. If possible, the entire rear axle with wheels should be rolled from under the vehicle.

##### Installing the entire rear axle

1. Install the entire rear axle with wheels under the vehicle.
2. Fit the axle suspension/guide.
3. Fit the control rod of the ALR valve.

**Note:**

Check the setting of the ALR valve following installation of the rear axle.

4. Fit the shock absorbers.
5. Fit the prop shaft to the drive flange.
6. Connect the electrical wiring and fit the air pipes.
7. Tighten the central bolt of the spring-brake cylinder.

**3.2 REMOVAL AND INSTALLATION, AXLE SHAFTS**

**Removing axle shafts**

1. Jack up the rear axle and support the axle on stands.
2. Drain the hub oil. See "Draining and filling".
3. Remove the attachment bolts from the hub cap and remove the hub cap.
4. Pull the axle shaft from the wheel hub.

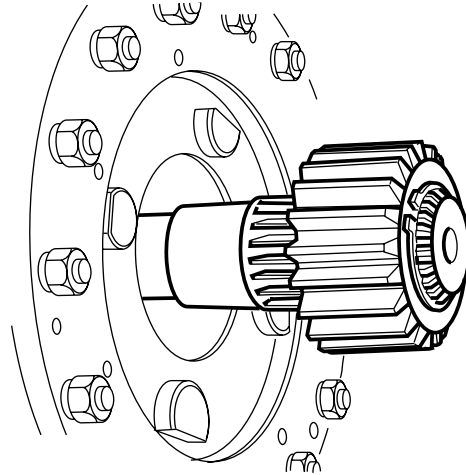

A800289

**Installing axle shafts**

1. Fit the axle shaft into the wheel hub.
2. Turn the planet-gear shafts so that the flat sides point outward.
3. Check the O-ring in the hub cap. If necessary, replace the O-ring. Apply silicone grease to the O-ring.
4. Install the spring assembly. Tighten the attachment bolts to the specified torque. See "Technical data".
5. Fill the hub with oil. See "Draining and filling".

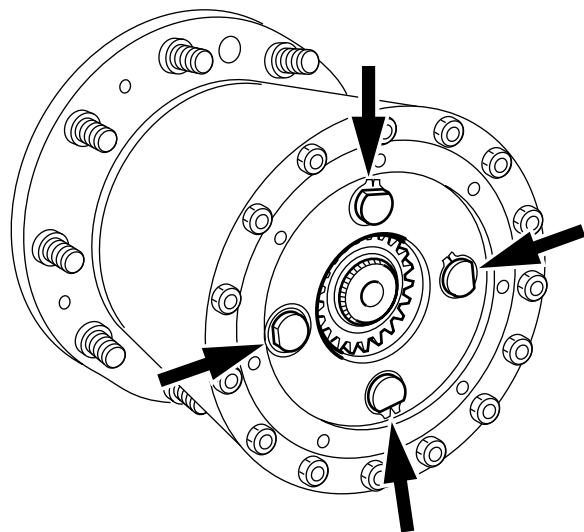

A800040

### 3.3 REMOVAL AND INSTALLATION, WHEEL HUB

#### Removing the wheel hub

1. Jack up the rear axle and support the axle on stands.
2. Remove the wheels.
3. Release the brakes and remove the brake drum.
4. Mark the hub at the semicircular hole in the cover.
5. Drain the oil. See "Draining and filling".
6. Remove the hub cap.
7. Remove the axle shaft.

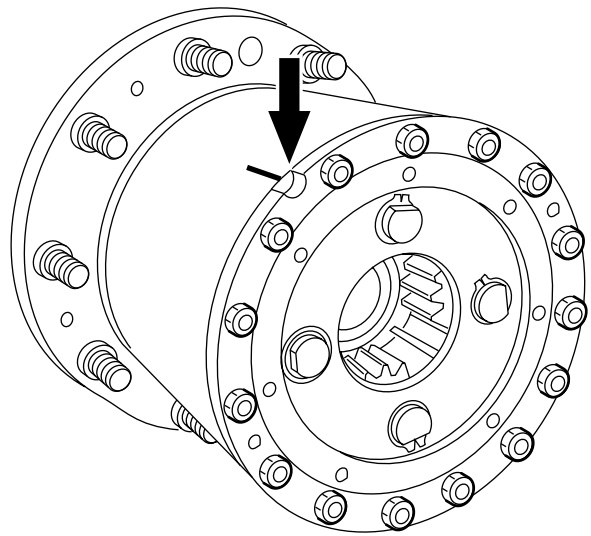

A800290

8. Remove the attachment nuts and tapered spring washers.  
Remove the planet-gear set from the hub using three jacking screws.

**Note:**

Make sure that the planet-gear set is put down with the circlips facing upward. This will prevent the pins from falling out.

9. Remove the thrust washer from the axle journal.
10. Remove the attachment bolts from the locking plate and remove the locking plate.

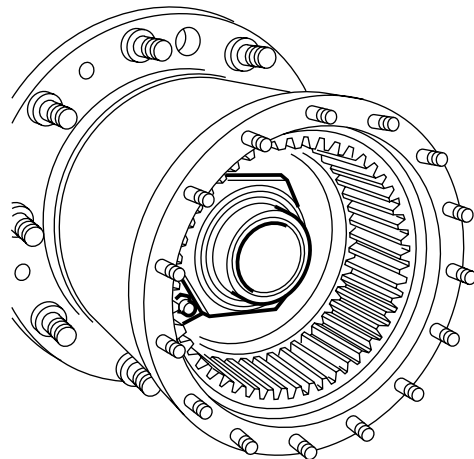

A800107

11. Remove the hub nut using special tool (DAF no. 0535705) and a torque amplifier (ratio 1 : 5).
12. Support the hub and pull it from the axle journal. The annular-gear carrier with the annular gear, the bearings and the spacer sleeve with spacer rings will be removed at the same time.
13. Remove the annular-gear carrier with the annular gear from the hub.

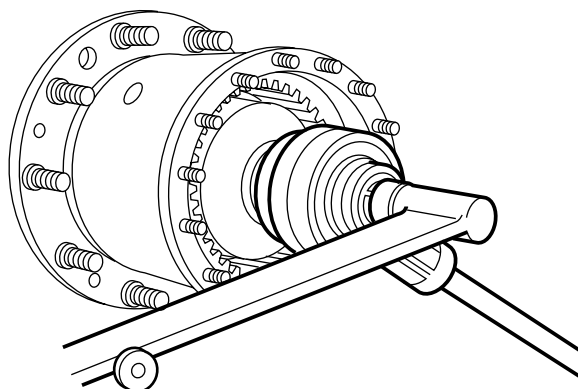

A800038

### Installing the wheel hub

#### Note:

If you have not replaced the wheel bearings and intend to reuse the original spacer sleeve with spacer rings, you need not readjust the wheel bearing pre-load.

If the wheel bearings have been replaced, the wheel bearing pre-load should be re-adjusted, see chapter "Inspection and adjustment". You must adjust the wheel bearing pre-load before fitting the hub seal.

1. Replace the hub seal.
2. Check the components for signs of wear and/or damage.
3. Replace the O-rings.
4. Apply oil to the wheel bearings.
5. Fit the hub on the axle journal.
6. Fit the original spacer sleeve and spacer rings.
7. Fit the inner race of the outer wheel bearing on the axle journal.
8. Fit the annular-gear carrier with the annular gear into the hub and on the splines of the axle journal.

9. Fit the hub nut and tighten it using special tool (DAF no. 0535705) and a torque amplifier (ratio 1 : 5). Tighten the hub nut to the specified tightening torque, see "Technical data". Turn the hub nut while tightening it.

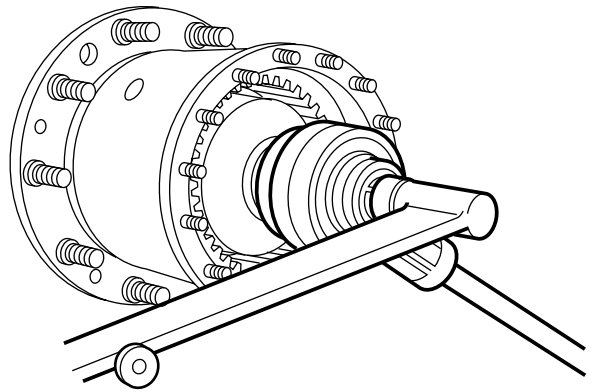

A800038

10. Fit the locking plate. Apply locking compound to the attachment bolts and tighten them to the specified torque. See "Technical data".
11. Install the thrust washer.

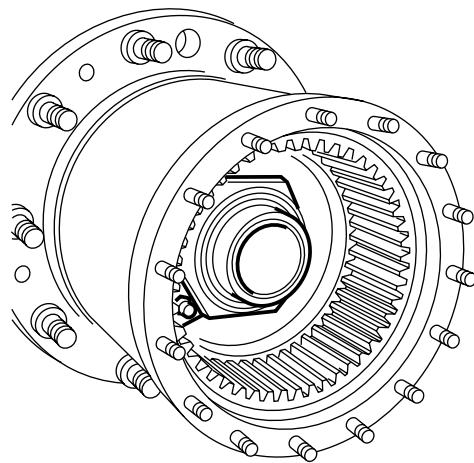

A800107

12. Fit the planet-wheel set in its original position in the hub (watch the markings).
13. Install the tapered spring washers and tighten them to the specified torque. See "Technical data".
14. Fit the axle shaft.
15. Check the O-ring in the hub cap. If necessary, replace the O-ring. Apply silicone grease to the O-ring.
16. Install the spring assembly. Tighten the attachment bolts to the specified torque. See "Technical data".
17. Fill the hub with oil. See "Draining and filling".

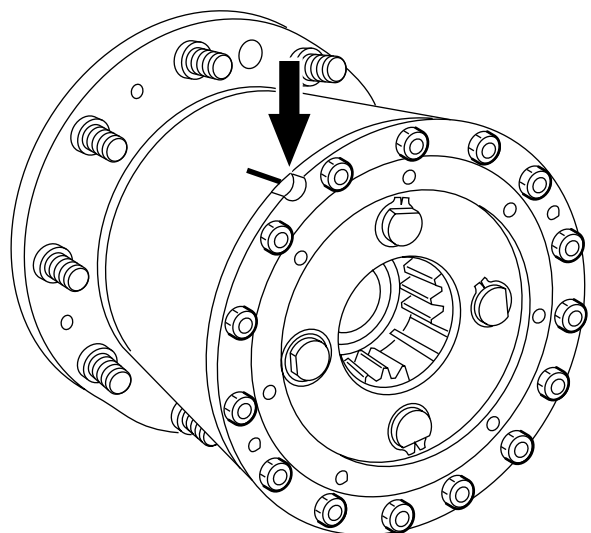

A800290

18. Press the sensor (2) against the sensor ring (1).  
While the vehicle is being driven, the air gap between the sensor and the sensor ring is adjusted automatically.

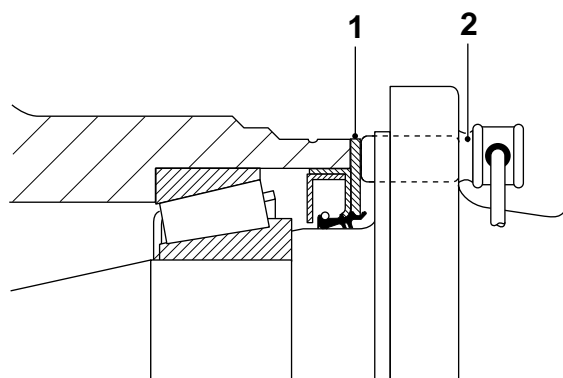

A8 00 347

**5**

**3.4 REMOVAL AND INSTALLATION, HUB SEAL/WHEEL SPEED SENSOR RING UNIT**

**Removing the hub seal/wheel speed sensor ring**

1. Remove the hub from the axle journal.
2. Fit special tool (3) (DAF no. 1329411) to the impact puller (2), special tool (DAF no. 0694928).  
Fit the special tool (3) behind the seal/sensor ring (1).  
Use the impact puller (2) to pull the seal/sensor ring (1) evenly from the hub.  
Once removed, the seal/sensor ring cannot be reused.

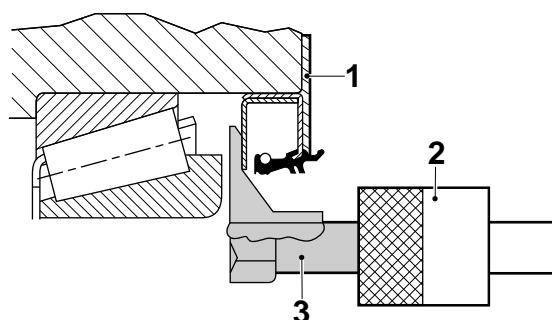

S7 00 424



### Installing the hub seal/wheel speed sensor ring

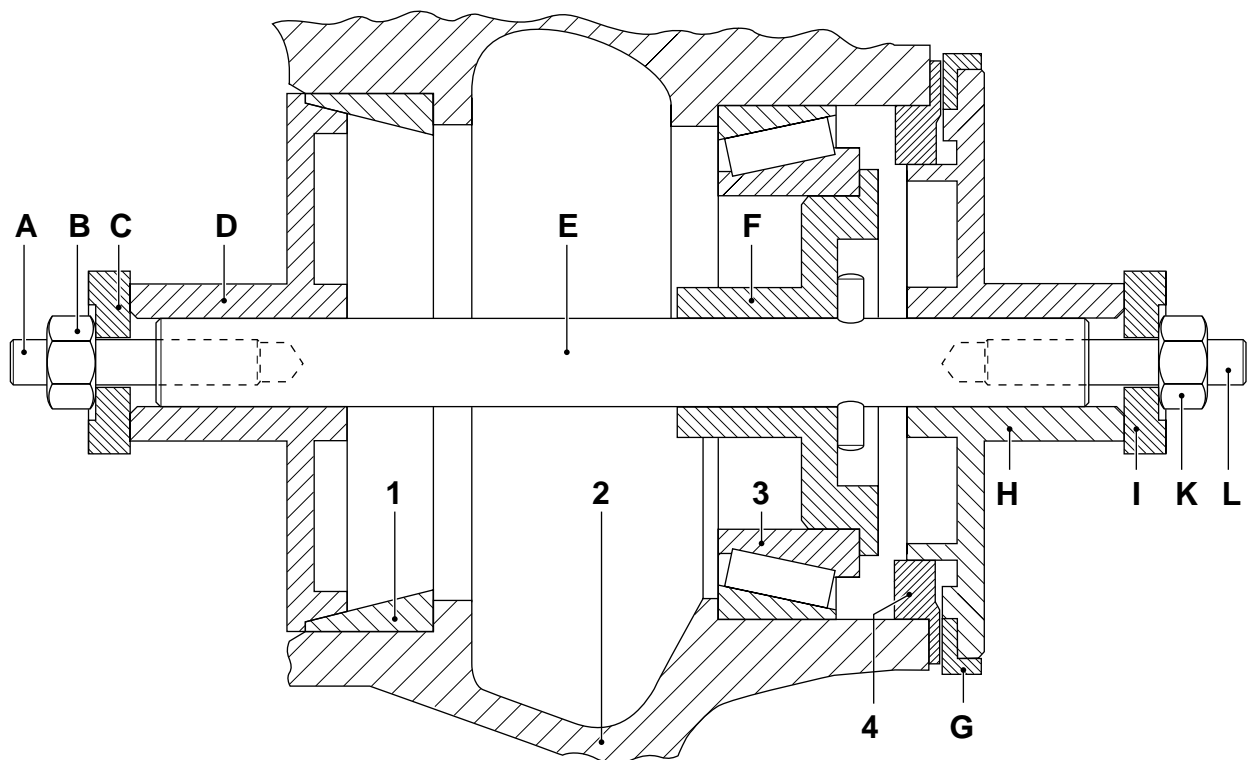

1. Check the recess for the seal/sensor ring (4) in the hub (2) for damage.
2. Use the special tool (DAF no. 1240036) to install the seal/sensor ring (4).

S7 00 405

3. Assemble the special tool: turn the threaded ends (A) and (L) into the centring spindle (E). Assemble the short stud (L) on the side where the pin has been fitted into the centring spindle (E).
4. Slide the appropriate centring flange (F) over the centring spindle (E).
5. Install the inner wheel bearing (3). Insert the centring spindle (E) together with the centring flange (F) into the hub (2).
6. Press the centring flange (F) into the inner wheel bearing (3).
7. Slide the appropriate centring flange (D) on the centring spindle (E).
8. Fit the retaining plate (C) and the nut (B) on the centring spindle (E).
9. Align the centring flange (D) on the outer race of the outer wheel bearing and hand-tighten nut (B) (max. 20 Nm). The centring spindle (E) must be installed in the hub (2) free of play.
10. Fit the ring (G) on the draw-in flange (H).
11. Position the seal/sensor ring (4) in front of the hub (2). Slide the draw-in flange (H) with the washer (G) over the centring spindle (E) against the seal/sensor ring (4).
12. Fit the retaining plate (I) and the nut (K).
13. Press the seal/sensor ring (4) evenly into the hub (2) using nut (K), until the sensor ring abuts the hub (2).
14. Remove the special tool.
15. Apply grease to the sealing lips of the seal/sensor ring (4).
16. Fit the hub on the axle journal.

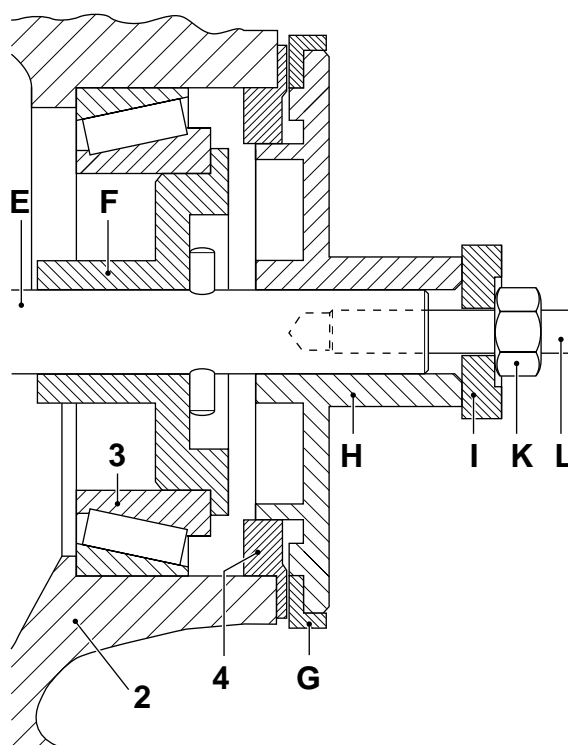

S7 00 411

### 3.5 REMOVAL AND INSTALLATION, WHEEL BEARINGS

#### Removing wheel bearings

1. Remove the wheel hub.
2. Remove the hub seal.
3. Remove the inner bearing.
4. Use a driver to tap the bearing outer races from the hub if the wheel bearings need to be replaced. For this purpose, the hub has been fitted with two recesses (A) and (B).

#### Installing wheel bearings

1. Clean the bearings and check them for signs of damage.
2. Use a driving tool and a hydraulic press to install the outer races into the hub. You can also tap the outer races evenly into the hub using a driver.
3. Fit the wheel hub.
4. Adjust the wheel bearing play until correct.

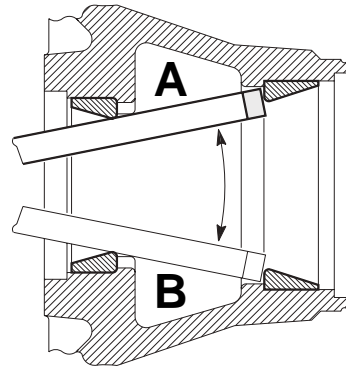

### 3.6 REMOVAL AND INSTALLATION, DRIVE FLANGE

#### Removing the drive flange

1. Remove the prop shaft from the drive flange.
2. Fit the special tool (B) (DAF no. 0484977) on the drive flange to prevent the flange from rotating. Remove the drive-flange nut using a torque amplifier (A).
3. Remove the drive flange. If necessary, use a puller.

#### Installing the drive flange

1. Before installation check the drive flange along the oil-seal running surface for grooves and/or sharp edges. If required, replace the drive flange.
2. Fit the drive flange.
3. Apply a small amount of grease to the first turn of the drive-flange nut.
4. Apply locking compound to the screw thread. See "Technical data".
5. Fit the special tool (B) (DAF no. 0484977) on the drive flange to prevent the flange from rotating. Fit the drive-flange nut. Use a torque amplifier (A) to tighten the drive-flange nut to the specified tightening torque, see "Technical data".
6. Fit the prop shaft to the drive flange.

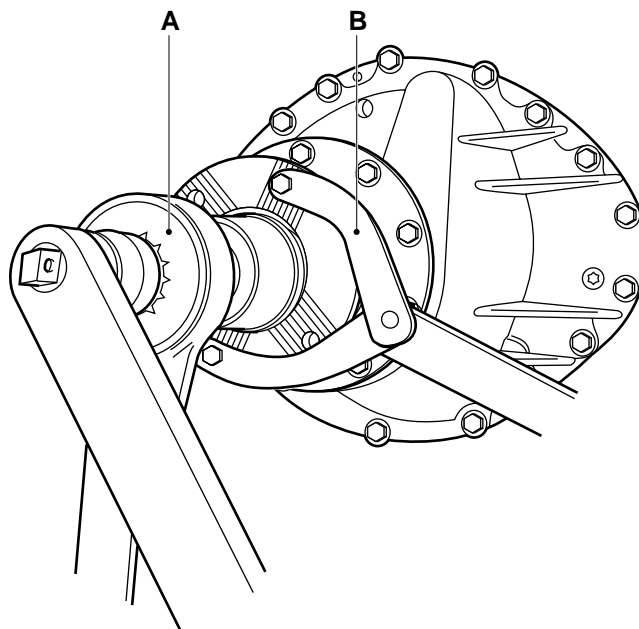

A8 00 357

### 3.7 REMOVAL AND INSTALLATION, PINION OIL SEAL

#### Removing the pinion oil seal

1. Remove the drive flange.
2. Drill two holes into the seal and screw the special tool (B) (DAF no. 0484899) into the seal. Pull the oil seal from the pinion housing using the special tool (A) (DAF no. 0694928).

#### Installing the pinion oil seal

1. Use the special tool (DAF no. 1240088) to fit the seal so that the inscription "outside" is pointed outwards.
2. Fit the drive flange.

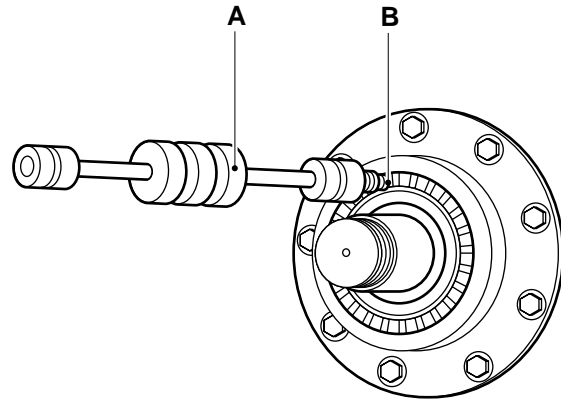

A8 00 426

### 3.8 REMOVAL AND INSTALLATION, DIFFERENTIAL

#### Removing the differential

1. Drain the oil from the differential and the hubs, see Chapter "Draining and filling".
2. Remove the prop shaft from the drive flange.
3. Remove the left axle shaft.
4. Pull the right axle shaft (i.e. on the side where the differential-gear lock cylinder is fitted) 15 - 18 cm from the hub.
5. Remove the air connection for the differential lock.
6. Slacken the locking nut of the differential lock cylinder and turn the differential lock cylinder out approx. one turn.
7. Attach the differential securely to a lifting device.
8. Remove the attachment bolts from the differential.
9. Remove the differential from the axle housing using two jacking screws.

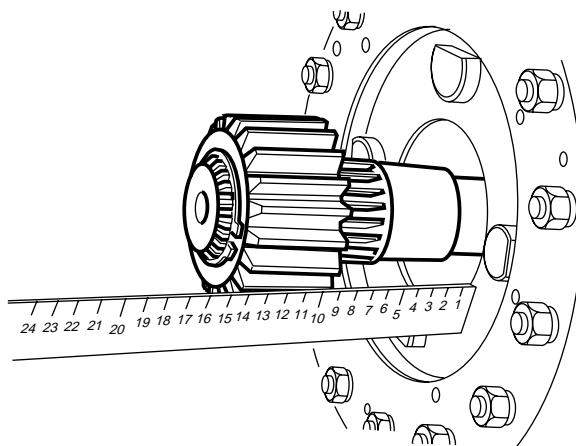

A800291

**Installing the differential**

1. Install the right axle shaft and slide it into the selector sleeve of the differential lock cylinder.
2. Slacken the engaging cylinder until the selector sleeve is positioned inside the edge of the axle housing.
3. Remove the jacking screws.
4. Clean the mating surfaces of the banjo housing and the differential housing and regrind the surfaces lightly. Do not damage the mating faces in the process.
5. Check the stud bolts for signs of damage. Replace the stud bolts if these are damaged. Apply locking compound to the new stud bolts, see "Technical data".
6. Apply a thin, even layer of sealant to the mating surface and around the stud bolts of the banjo housing, see "Technical data".
7. Fit the differential into the banjo housing. Evenly tighten the nuts. Tighten the nuts to the specified tightening torque, see "Technical data".
8. Install the left axle shaft and slide both axle shafts into the differential.
9. Tighten the engaging cylinder while turning the right wheel at the same time, until the teeth of the selector sleeve and the satellite-gear housing engage.
10. Slacken the engaging cylinder 1.5 turns and tighten the lock nut to the specified tightening torque, see "Technical data".
11. Fit the air connection to the differential lock.
12. Fit the prop shaft to the drive flange.
13. Fill the differential and the hubs with oil. See "Draining and filling".

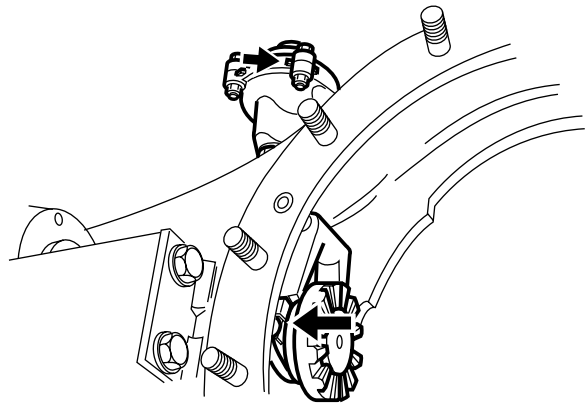

A800024

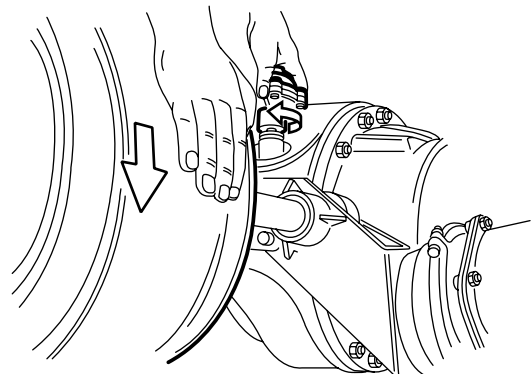

A800035

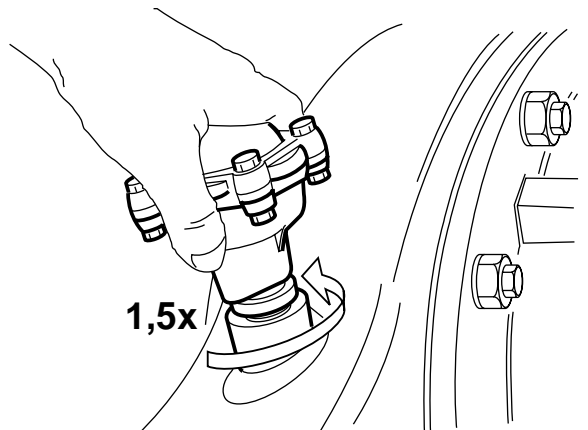

A800034

**3.9 REMOVAL AND INSTALLATION, DIFFERENTIAL LOCK**

**Removing the differential lock**

1. Remove the differential.
2. Remove the yoke axle (5) from the yoke (6) using a home-made yoke puller (A800151).

**5**

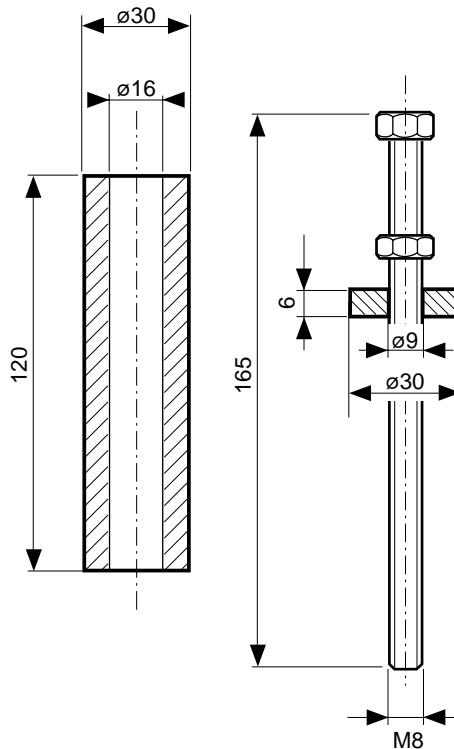

A800151

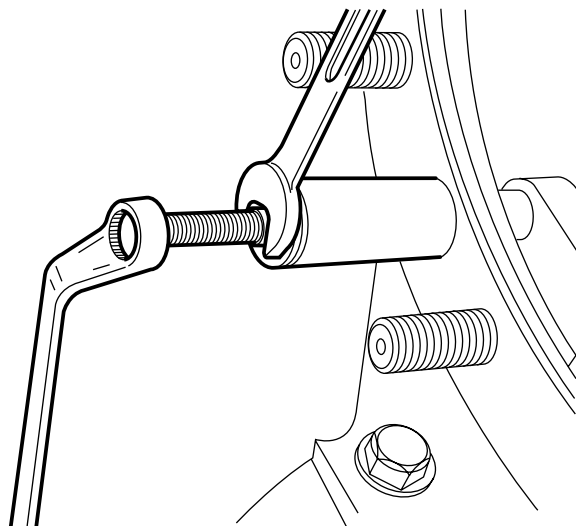

A800026



3. Remove the split pin (4), ring (3) and yoke pin (2) and remove the yoke (6) from the axle housing.
4. Remove the floating blocks (7) from the yoke (6).
5. Turn the pneumatic cylinder (1) out of the housing.
6. Check the tothing of the selector sleeve (9) and the right satellite-gear housing flange for signs of damage and wear.
7. Check whether the selector sleeve moves smoothly over the axle shaft.
8. Check whether the yoke (6) moves smoothly over the axle (5).
9. If the tothing of the satellite-gear housing flange appears to be damaged, you must not only replace this flange but also the entire satellite-gear housing. You cannot replace these two components separately.
10. If necessary, remove the engaging cylinder and check the various parts for signs of damage.

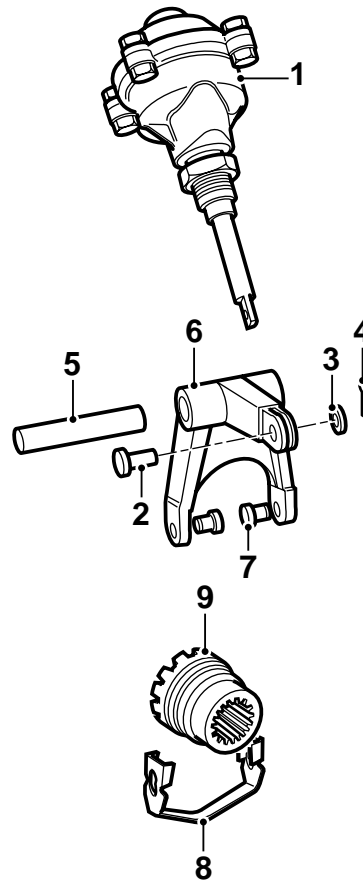

A800021

#### Installing the differential lock

1. Turn the engaging cylinder (1) with lock nut entirely into the axle housing.

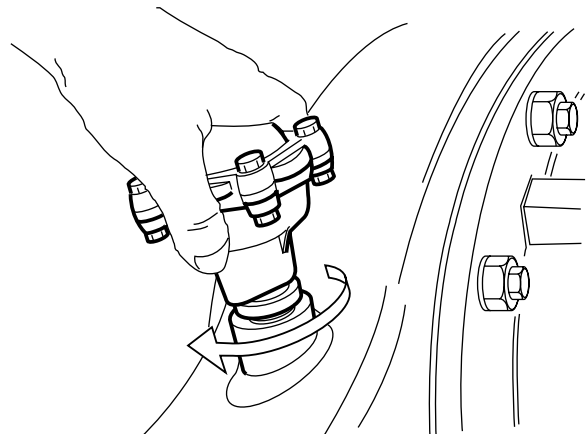

A800028

2. Fit the yoke (6) with yoke pin (2), ring (3) and split pin (4) to the cylinder control rod.

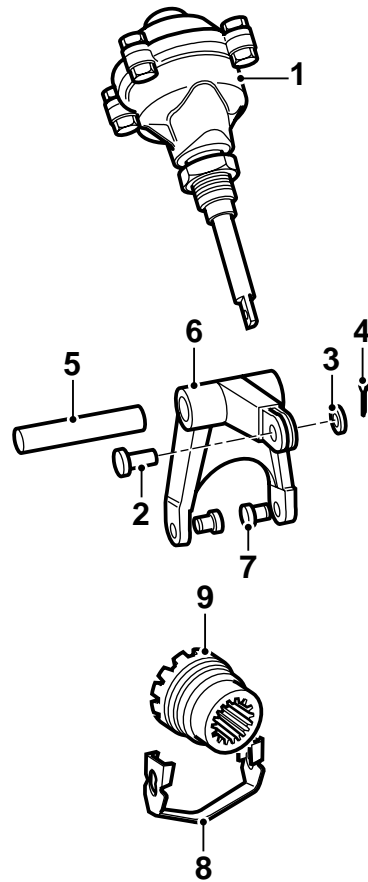

A800021

3. Install the yoke with axle into the differential housing, making sure that the threaded hole of the axle points outward (see arrow).
4. Use a nylon or copper hammer to tap the axle into the axle housing until the axle journal is positioned flush with or slightly lower than the mating surface of axle housing and differential.

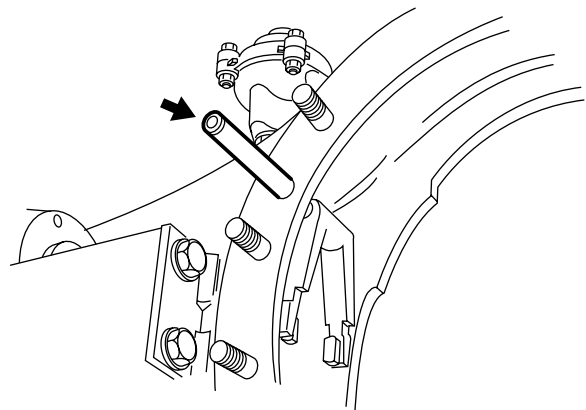

A800030

**5**

5. Fit the floating blocks (7) into the yoke (6). Fit the selector sleeve (9) with the spring clip (8) into the yoke. Pull the spring clip (8) downward on both sides, so that the narrowest part of the semicircular holes is positioned behind the edges of the floating blocks.
6. Install the right axle shaft and slide it into the selector sleeve.

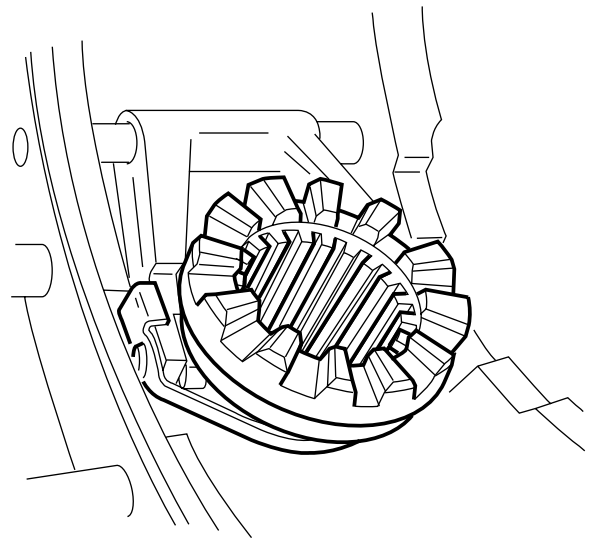

A800031

7. Slacken the engaging cylinder until the selector sleeve is positioned inside the edge of the axle housing. Make sure that the axle shaft end is flush with the top of the selector sleeve tooting.
8. Install the differential.

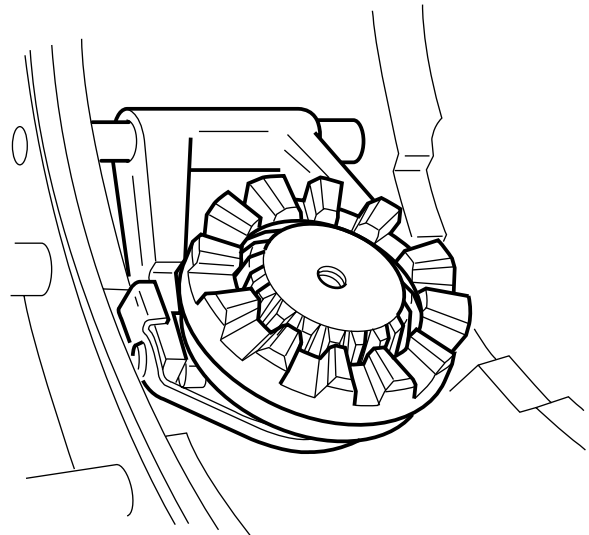

A800032



## 4. DRAINING AND FILLING

### 4.1 DRAINING AND FILLING, HUB



To prevent skin injury, avoid unnecessary contact with the drained oil.

#### Draining the hub

1. Position the vehicle on a level surface.
2. Position the wheels in such a way that the oil drain/filler plug (A) is on the underside.
3. Remove the oil level check plug (B) and oil drain/filler plug (A).
4. Drain the oil and let the oil leak out of the hub.

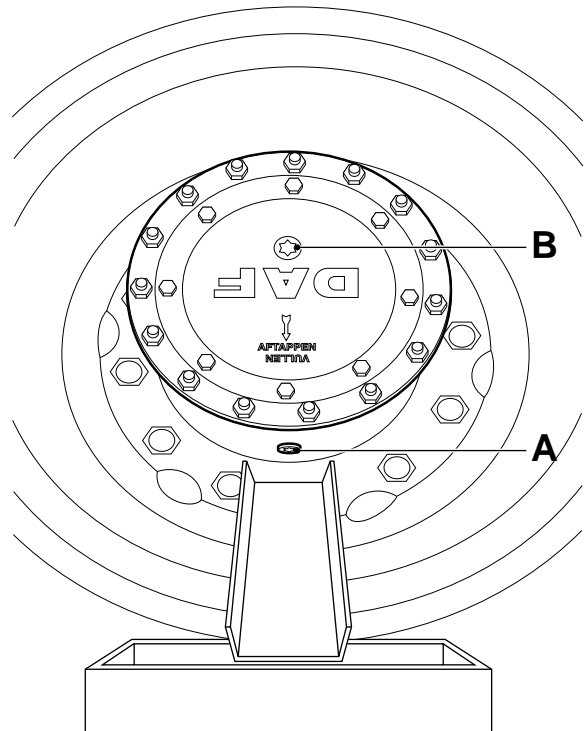

A8 00 363

**Filling the hub**

1. Position the wheels in such a way that the oil drain/filler plug (A) is at the top.
2. Fill the hub with the specified quantity of oil. See "Technical data".
3. Check the oil level after approximately 5 minutes. See "Inspection and adjustment".
4. Fit the plugs using the special Torx wrench (DAF no. 1329493) and tighten to the specified torque; see "Technical data".

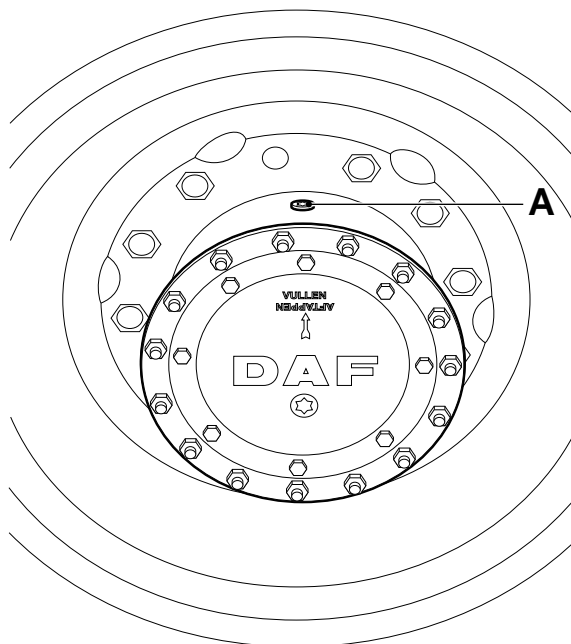

A8 00 364

## 4.2 DRAINING AND FILLING, DIFFERENTIAL



To prevent skin injury, avoid unnecessary contact with the drained oil.

### Draining the differential

1. Position the vehicle on a level surface.
2. Remove the level check/filler plug (A) and drain plug (B). Drain the oil.
3. Fit the drain plug (B) using the special Torx wrench (DAF no. 1329493) and tighten to the specified torque; see "Technical data".

### Filling the differential

1. Fill the differential via the level check/filler plug (A) with the specified quantity of oil, see "Technical data".
2. Check the oil level after approx. 5 minutes. The oil level should now have reached the level check/filler opening. See "Inspection and adjustment".
3. Fit the level check/filler plug (A) using the special Torx wrench (DAF no. 1329493) and tighten to the specified torque; see "Technical data".

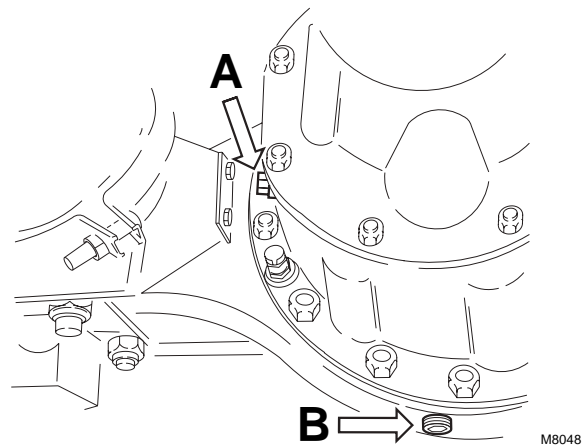





## CONTENTS

	Page	Date
<b>1. GENERAL</b> .....	1-1	200424
1.1 Description .....	1-1	200424
1.2 Overview drawing, wheel hub .....	1-2	200424
<b>2. INSPECTION AND ADJUSTMENT</b> .....	2-1	200424
2.1 Inspection and adjustment, wheel bearing play .....	2-1	200424
2.2 Checking the hub oil levels .....	2-4	200424
2.3 Draining and filling, differential .....	2-5	200424
2.4 Checking the operation of the differential lock .....	2-6	200424
2.5 Checking the hub and wheel bearings .....	2-6	200424
2.6 Checking the wheel speed sensor ring .....	2-7	200424
<b>3. REMOVAL AND INSTALLATION</b> .....	3-1	200424
3.1 Removal and installation, entire rear axle .....	3-1	200424
3.2 Removal and installation, axle shafts .....	3-2	200424
3.3 Removal and installation, wheel hub .....	3-4	200424
3.4 Removal and installation, hub seal/wheel speed sensor ring unit .....	3-6	200424
3.5 Removal and installation, wheel bearings .....	3-8	200424
3.6 Removal and installation, drive flange .....	3-9	200424
3.7 Removal and installation, input shaft pinion oil seal .....	3-10	200424
3.8 Removal and installation, output shaft pinion oil seal .....	3-10	200424
3.9 Removal and installation, differential .....	3-11	200424
3.10 Removal and installation, differential lock .....	3-12	200424
<b>4. DRAINING AND FILLING</b> .....	4-1	200424
4.1 Draining and filling, hub .....	4-1	200424
4.2 Draining and filling, differential .....	4-2	200424



## 1. GENERAL

### 1.1 DESCRIPTION

The tandem rear axle 1132T consists of two 1132 rear axles.

In the first axle the torque is divided over the first and second axle. To enable speed differences between the two axles, a so-called third differential is installed. If required, the differential can be locked. Via the axle shafts the torque is transferred to the wheel hubs; a single reduction is applied.

The differentials are equipped with a hypoid bevel gear.

#### **Differential lock**

The 1132 T differential is equipped with a variable differential lock.

The satellite-gear housing flange is fitted with spline toothing at the right. The left side of the selector sleeve is equipped with similar toothing. The selector sleeve is fitted with splines, similar to the splines in the axle shaft.

The outside of the selector sleeve is fitted with a groove, in which a fork fits which is attached to the engaging cylinder.

#### **Operation of differential lock**

If the engaging cylinder is pressurised using a pneumatic switch, the toothing of the selector sleeve will mesh with the toothing of the satellite-gear housing.

If the engaging cylinder is vented via the pneumatic switch, the spring will ensure that the lock is deactivated.

1.2 OVERVIEW DRAWING, WHEEL HUB

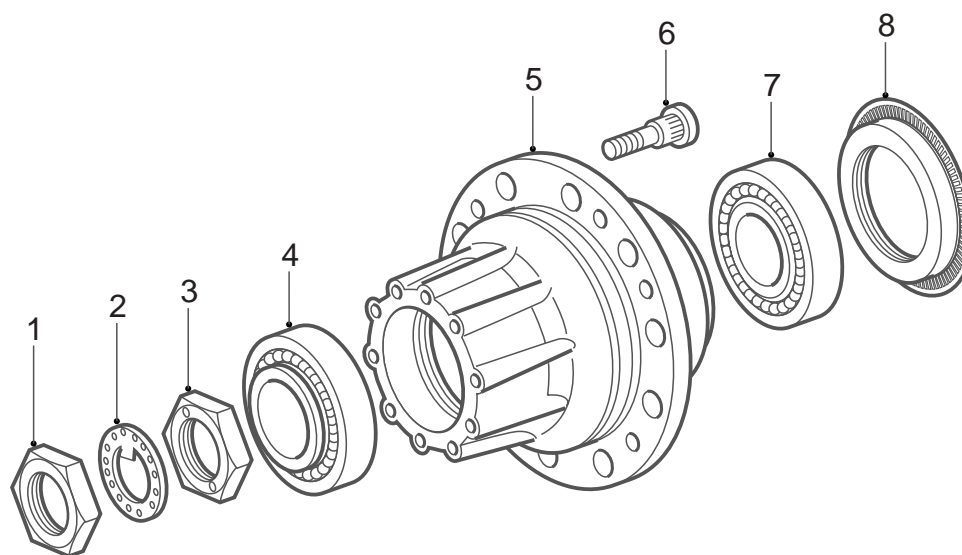

A8 00 425

6

- 1. Lock nut
- 2. Circlip
- 3. Hub nut
- 4. Bevelled roller bearing
- 5. Hub
- 6. Wheel stud
- 7. Bevelled roller bearing
- 8. Hub oil seal/wheel speed sensor ring

## 2. INSPECTION AND ADJUSTMENT

### 2.1 INSPECTION AND ADJUSTMENT, WHEEL BEARING PLAY

#### Checking the wheel bearing play

1. Jack up the rear axle and support the axle on stands.
2. Drain the hub oil. See "Draining and filling".
3. Remove the axle shafts. See "Removal and installation".
4. Use the special tool (DAF no. 0535595) for checking the wheel bearing play.
5. Remove two opposite wheel nuts.

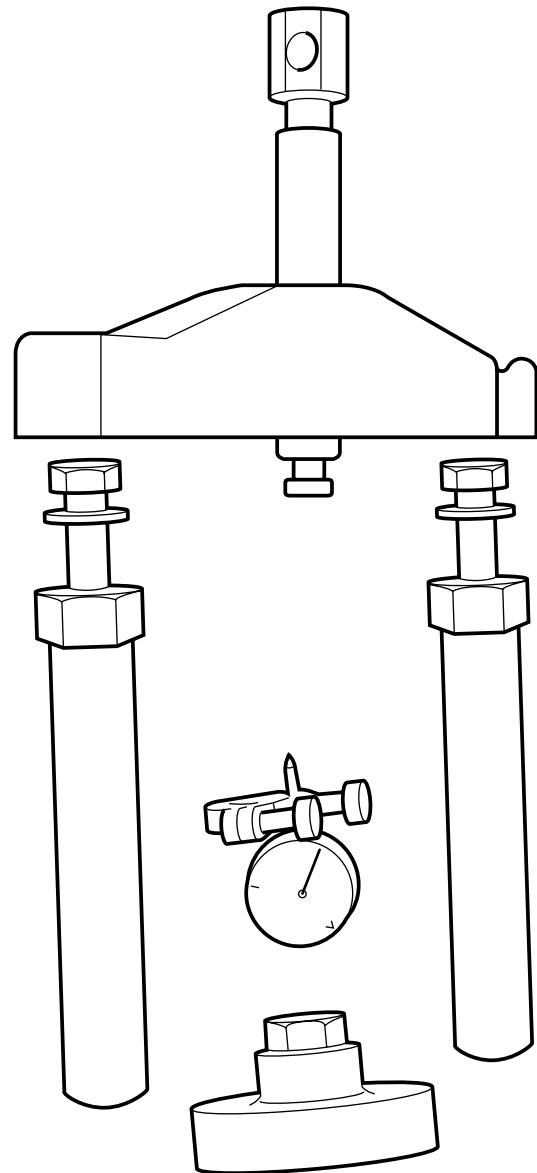

W807008

6. Fit the extensions of the special tool to the now vacant wheel studs.
7. Always clean the measuring surface thoroughly and tighten the central nut on the shaft journal.
8. Place the dial gauge holder on the central nut. Place the dial gauge so that the stylus abuts the hub.
9. Screw the spindle into the bridge and fit it to the extensions so that the end of the spindle fits into the recess of the central nut. Tighten the bridge with the nuts.

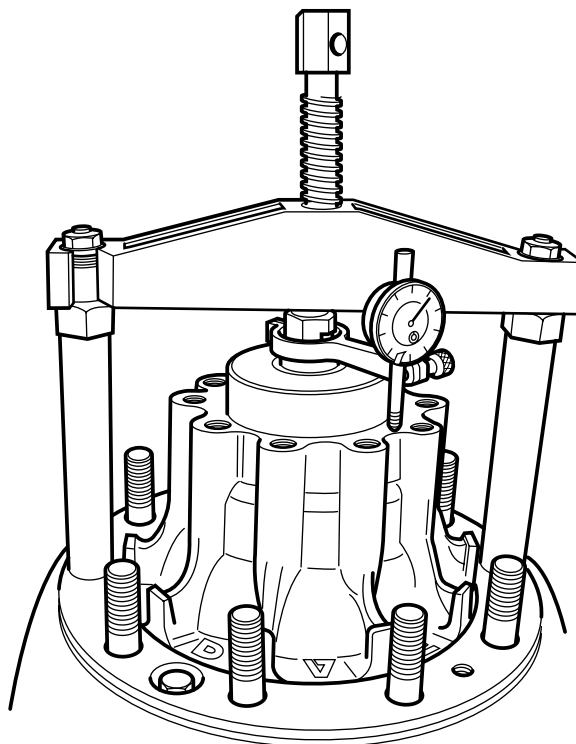

A800149

6

10. Press the hub firmly on to the axle journal by screwing the spindle anti-clockwise, to a tightening torque of 40 Nm.



M8130

11. Withdraw the hub by screwing the spindle clockwise, to a tightening torque of 40 Nm.

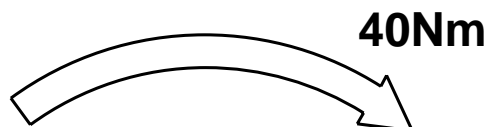

M8131

12. Press the hub firmly on to the axle journal by screwing the spindle anti-clockwise, to a tightening torque of 15 Nm. Set the dial gauge to "0".

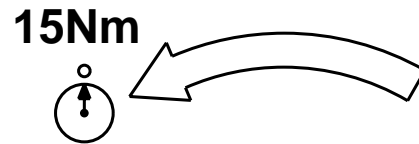

M8132

13. Withdraw the hub by screwing the spindle clockwise, to a tightening torque of 15 Nm. The value on the dial gauge should equal that in the technical data. See "Technical data".
14. Readjust the wheel bearing play if a deviating value is measured.

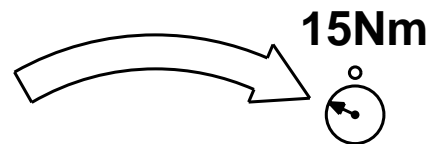

M8133

#### Adjusting the wheel bearing play

1. Tighten the hub nut using special tool (DAF no. 0694894) to a torque of 100 Nm, while turning the hub.
2. Turn the hub nut anti-clockwise 45° and 60° until the dowel pin of the axle nut falls into the holes of the circlip. This way the prescribed wheel bearing play is achieved.
3. Fit the circlip and the lock nut. Tighten the hub nut to the specified torque using the special tool (DAF no. 0694894), see "Technical data".

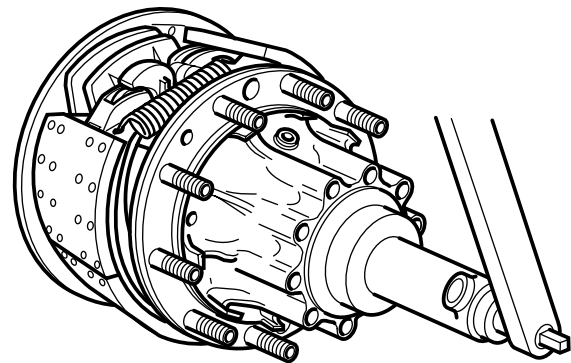

A800148

## 2.2 CHECKING THE HUB OIL LEVELS



To prevent skin injury, avoid unnecessary contact with the drained oil.

1. Position the vehicle on a level surface.
2. Position the wheels so that the arrow on the hub is pointing upwards.
3. Remove the oil-level check/filler plug (A). The oil level should reach the level check/filler opening.
4. Fit the plug using the special Torx wrench (DAF no. 1329493) and tighten to the specified torque; see "Technical data".

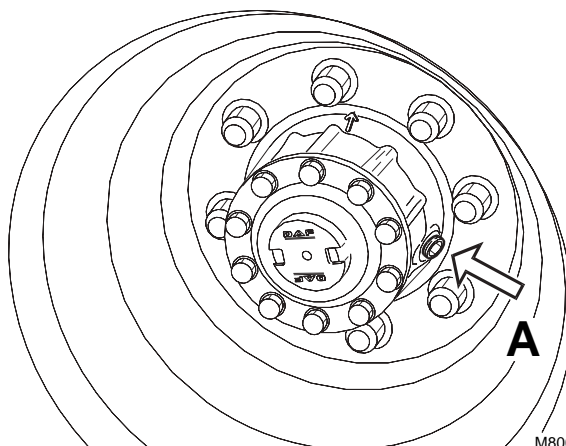



### 2.3 DRAINING AND FILLING, DIFFERENTIAL



To prevent skin injury, avoid unnecessary contact with the drained oil.

#### Checking the oil level, first axle

1. Position the vehicle on a level surface.
2. Remove the level check/filler plug (A). The oil level should have reached the level check/filler opening.
3. Fit the level check/filler plug (A) using the special Torx wrench (DAF no. 1329493) and tighten to the specified torque; see "Technical data".

#### Checking the oil level, second axle

1. Position the vehicle on a level surface.

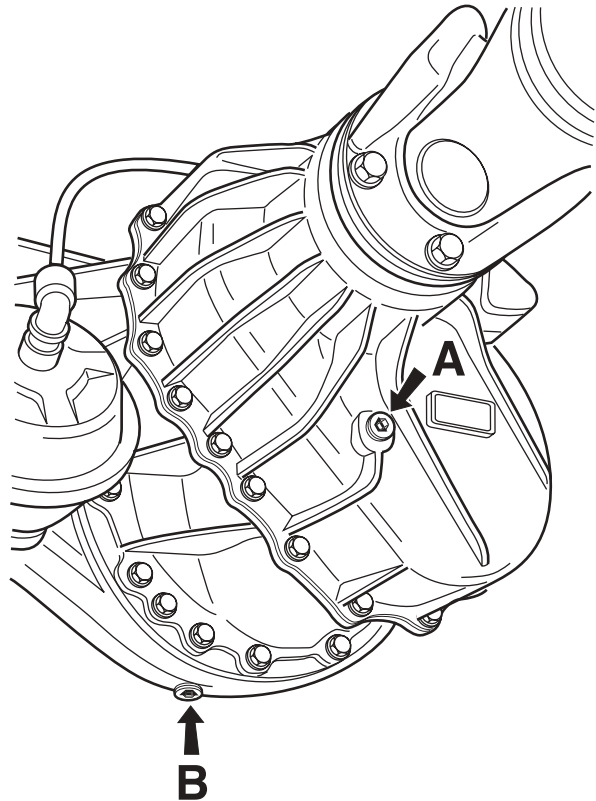

GO 00 268

2. Remove the level check/filler plug (A). The oil level should have reached the level check/filler opening.
3. Fit the level check/filler plug (A) using the special Torx wrench (DAF no. 1329493) and tighten to the specified torque; see "Technical data".

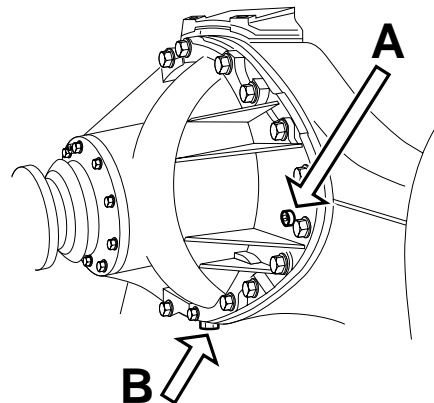

M8013

**2.4 CHECKING THE OPERATION OF THE DIFFERENTIAL LOCK**

1. Jack up the rear axle and support the axle on stands.
2. Bring the air system to operating pressure.
3. Engage the differential lock. The warning lamp should now come on.
4. Check that there is a "rigid" connection between the driven wheels.
5. Disengage the differential lock. The warning lamp should not light up and the "rigid" connection between the driven wheels should be broken.

**2.5 CHECKING THE HUB AND WHEEL BEARINGS****6**

1. Inspect the bearings for damage at the following points:
  - the roller bearing race,
  - the bearing cage,
  - the raceways of the inner and outer race.If damage is found, the entire bearing (inner race/bearing cage and outer race) should be replaced.
2. If the outer race of the bearing is loose in the hub or has turned in the hub, the hub should be replaced.
3. Check the axle journal screw thread, the bearing surfaces of the inner bearing races and the running surface of the seal for damage.
4. Check the wheel speed sensor ring for damage. Replace the ring at even the slightest trace of damage.

## 2.6 CHECKING THE WHEEL SPEED SENSOR RING

1. Remove the wheel hub. See "Removal and installation".
2. Check the sensor ring (1) for deposits. Special attention should be paid to deposits between the teeth of the sensor ring. Clean the sensor ring if necessary.
3. Check the sensor ring (1) for damage. Even the slightest damage can cause a failure. If necessary replace the sensor ring.
4. If possible, the sensor ring (1) should be checked for the maximum admissible axial end play. See "Technical data".
5. Check the sensor (2) for freedom of movement. If necessary, clean the sensor and apply new grease.

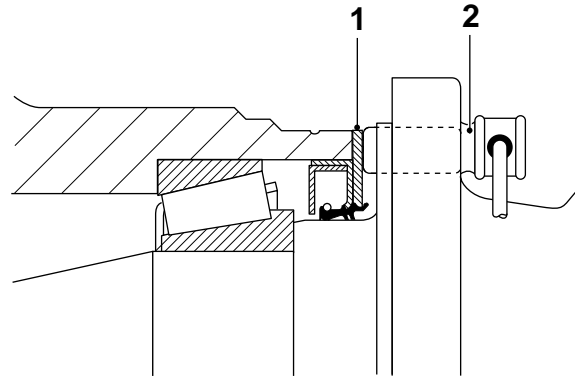

A8 00 347



### 3. REMOVAL AND INSTALLATION

#### 3.1 REMOVAL AND INSTALLATION, ENTIRE REAR AXLE

##### Removing the entire rear axle

1. Block the front wheels using chocks.
2. Slacken the central bolt of the spring-brake cylinder as much as possible.
3. Apply the parking brake.
4. Remove the air pipes and wiring.
5. Remove the prop shaft from the drive flange.
6. Loosen the shock absorbers on the bottom.
7. Loosen the control rod of the ALR valve.
8. Support the vehicle securely with stands under the chassis side members.
9. Remove the axle suspension/guide.  
Take precautionary measures to make sure that the axle does not tilt during removal of the axle suspension/guide.
10. If possible, the entire rear axle with wheels should be rolled from under the vehicle.

##### Installing the entire rear axle

1. Install the entire rear axle with wheels under the vehicle.
2. Fit the axle suspension/guide.  
Make sure that the torque-rod supports are fitted so that arrow **A** on the support points in the driving direction.
3. Fit the control rod of the ALR valve.

**Note:**

Check the setting of the ALR valve following installation of the rear axle.

4. Fit the shock absorbers (if applicable).
5. Fit the prop shaft to the drive flange.
6. Connect the electrical wiring and fit the air pipes.
7. Tighten the central bolt of the spring-brake cylinder.

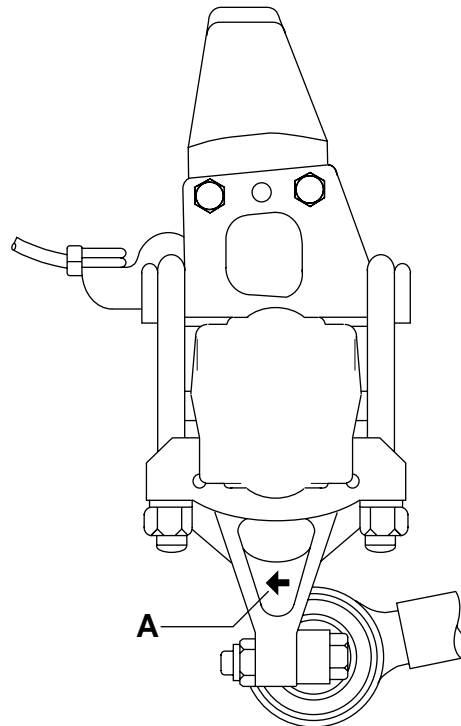

A800045

### 3.2 REMOVAL AND INSTALLATION, AXLE SHAFTS

#### Removing axle shafts

1. Jack up the rear axle and support the axle on stands.
2. Engage the differential lock. Check whether the axle is blocked. Replace the switch by the special tool (DAF no. 1329447), see (A). This is to prevent the sliding sleeve from falling into the differential when removing the axle shaft.

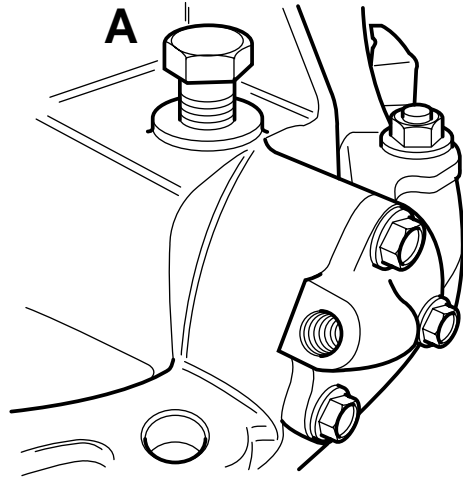

A800139

3. Remove the axle-shaft attachment bolts.
4. Remove the axle shaft using special tool (DAF no. 0694980), if required, see (B). When the axle shaft comes loose, a small amount of oil may leak out. Collect this oil.

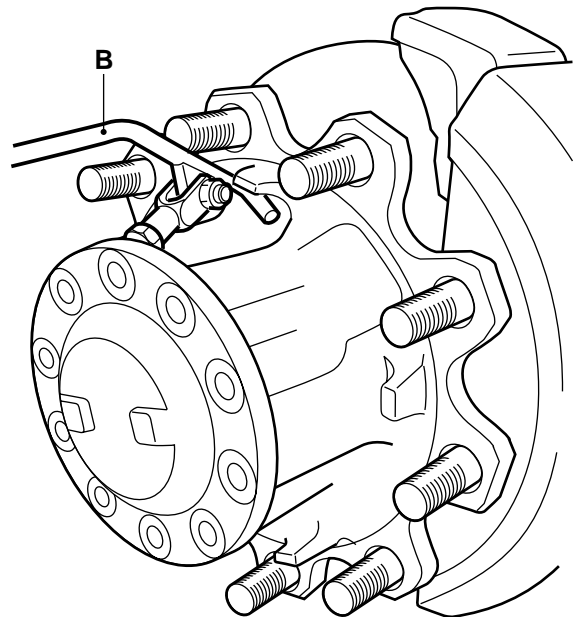

A8 00 351

**Installing axle shafts**

1. Clean the mating surfaces of the axle shaft flange and wheel hub unit.
2. Apply sealant to the mating surface of the axle shaft flange. See "Technical data".
3. Fit the axle shaft. Tighten the axle shaft attachment bolts to the specified tightening torque, see "Technical data".
4. Activate the differential lock and remove the special tool from the differential lock. Install the switch.

### 3.3 REMOVAL AND INSTALLATION, WHEEL HUB

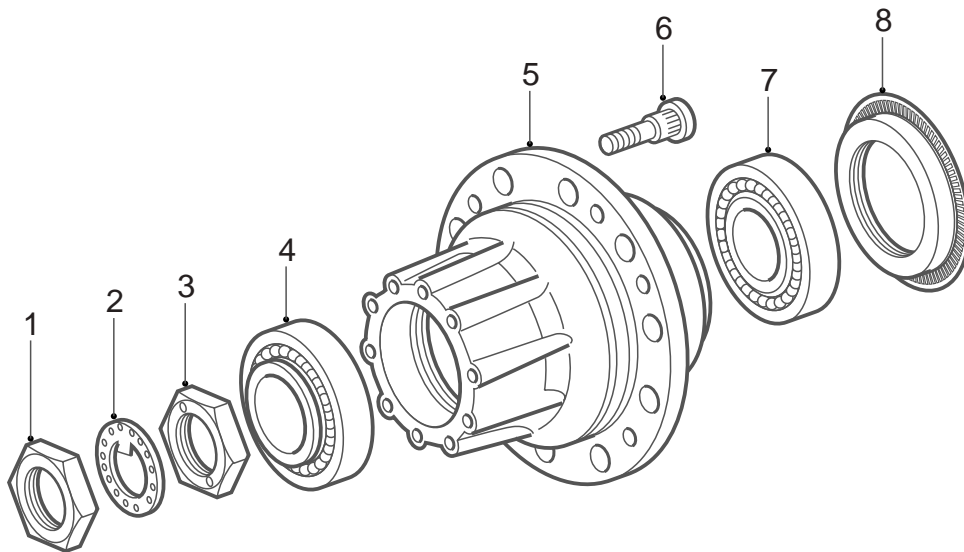

A8 00 425

## 6

#### Removing the wheel hub

1. Jack up the rear axle and support the axle on stands.
2. Remove the wheels.
3. Release the brakes.
4. Remove the brake drum.
5. Remove the axle shaft.
6. Remove the lock nut (1) using special tool (DAF no. 0694894).
7. Remove the circlip (2).
8. Remove the hub nut (3) using special tool (DAF no. 0694894).
9. Remove the wheel hub from the axle journal.

#### Installing the wheel hub

1. Replace the wheel hub oil seal.
2. Oil the axle journal and the inner and outer bearing and slide the wheel hub over the axle journal. Use the outer bearing as a guide.
3. Fit the hub nut and adjust the wheel bearing play. See "Inspection and adjustment".



4. Press the wheel speed sensor (2) up against the sensor ring (1).  
While the vehicle is being driven, the air gap between the sensor and the sensor ring is adjusted automatically.
5. Fit the axle shaft.
6. Fit the brake drum.
7. Put the wheels back on.
8. Adjust the brakes.

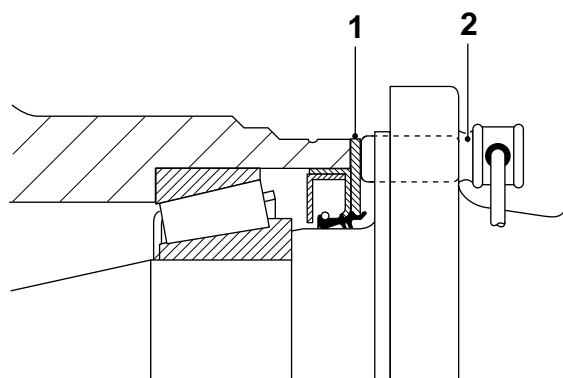

A8 00 347

**3.4 REMOVAL AND INSTALLATION, HUB SEAL/WHEEL SPEED SENSOR RING UNIT**

**Removing the hub seal/wheel speed sensor ring**

1. Remove the hub from the axle journal.
2. Fit special tool (3) (DAF no. 1329411) to the impact puller (2), special tool (DAF no. 0694928).  
Fit the special tool (3) behind the seal/sensor ring (1).  
Use the impact puller (2) to pull the seal/sensor ring (1) evenly from the hub.  
Once removed, the seal/sensor ring cannot be reused.

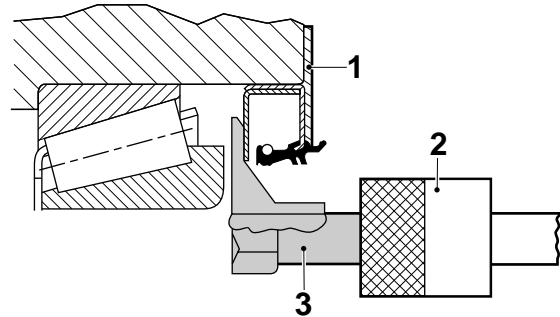

S7 00 424

**Installing the hub seal/wheel speed sensor ring**

6

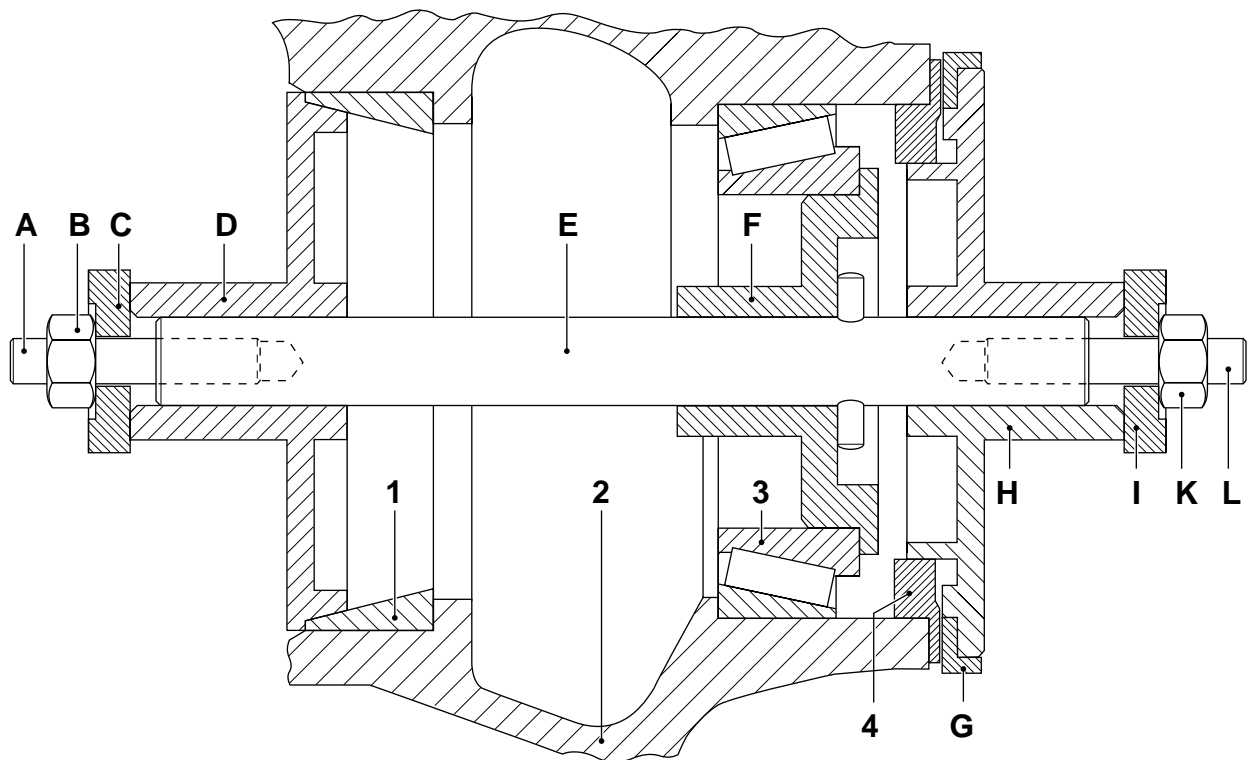

S7 00 405

1. Check the recess for the seal/sensor ring (4) in the hub (2) for damage.
2. Use the special tool (DAF no. 1240036) to install the seal/sensor ring (4).

3. Assemble the special tool: turn the threaded ends (A) and (L) into the centring spindle (E). Assemble the short stud (L) on the side where the pin has been fitted into the centring spindle (E).
4. Slide the appropriate centring flange (F) over the centring spindle (E).
5. Install the inner wheel bearing (3). Insert the centring spindle (E) together with the centring flange (F) into the hub (2).
6. Press the centring flange (F) into the inner wheel bearing (3).
7. Slide the appropriate centring flange (D) on the centring spindle (E).
8. Fit the retaining plate (C) and the nut (B) on the centring spindle (E).
9. Align the centring flange (D) on the outer race of the outer wheel bearing and hand-tighten nut (B) (max. 20 Nm). The centring spindle (E) must be installed in the hub (2) free of play.
10. Fit the ring (G) on the draw-in flange (H).
11. Position the seal/sensor ring (4) in front of the hub (2). Slide the draw-in flange (H) with the washer (G) over the centring spindle (E) against the seal/sensor ring (4).
12. Fit the retaining plate (I) and the nut (K).
13. Press the seal/sensor ring (4) evenly into the hub (2) using nut (K), until the sensor ring abuts the hub (2).
14. Remove the special tool.
15. Apply grease to the sealing lips of the seal/sensor ring (4).
16. Fit the hub on the axle journal.

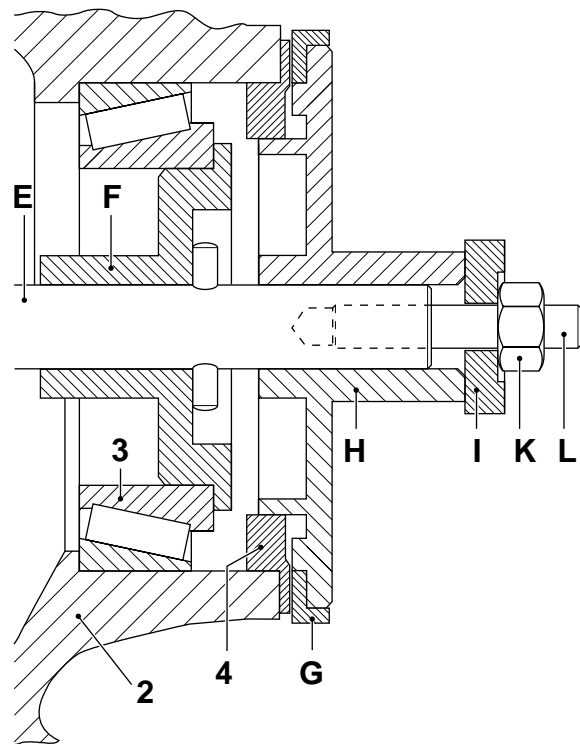

S7 00 411

### 3.5 REMOVAL AND INSTALLATION, WHEEL BEARINGS

#### Removing wheel bearings

1. Remove the wheel hub.
2. Remove the hub seal.
3. Remove the bearing cages.
4. If the wheel bearings should be replaced, the outer bearing races can be tapped from the hub using a driving tool. For this purpose, the hub has been fitted with two recesses (A) and (B).

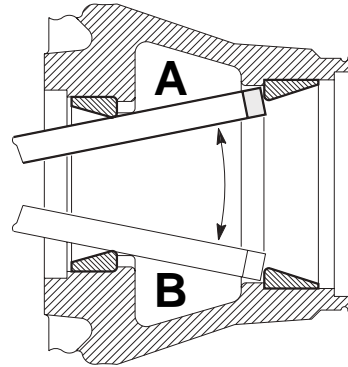

#### Installing wheel bearings

1. Clean the bearings and check them for signs of damage.
2. Use a driving tool and a hydraulic press to install the outer races into the hub. You can also tap the outer races evenly into the hub using a driver.
3. Fit the wheel hub.
4. Tighten the adjusting nut to a torque of 100 Nm and turn the hub a few revolutions so that the wheel bearings can set.
5. Retighten the adjusting nut to a torque of 100 Nm and adjust the wheel bearing play, see "Inspection and adjustment, wheel bearings".

M8120

### 3.6 REMOVAL AND INSTALLATION, DRIVE FLANGE

#### Removing the drive flange

1. Remove the prop shaft from the drive flange.
2. Fit the special tool (B) (DAF no. 0484977) on the drive flange to prevent the flange from rotating. Remove the drive-flange nut using a torque amplifier (A).
3. Remove the drive flange. If necessary, use a puller.

#### Installing the drive flange

1. Before installation check the drive flange along the oil-seal running surface for grooves and/or sharp edges. If required, replace the drive flange.
2. Fit the drive flange.
3. Apply a small amount of grease to the first turn of the drive-flange nut.
4. Apply locking compound to the screw thread. See "Technical data".
5. Fit the special tool (B) (DAF no. 0484977) on the drive flange to prevent the flange from rotating. Fit the drive-flange nut. Use a torque amplifier (A) to tighten the drive-flange nut to the specified tightening torque, see "Technical data".
6. Fit the prop shaft to the drive flange.

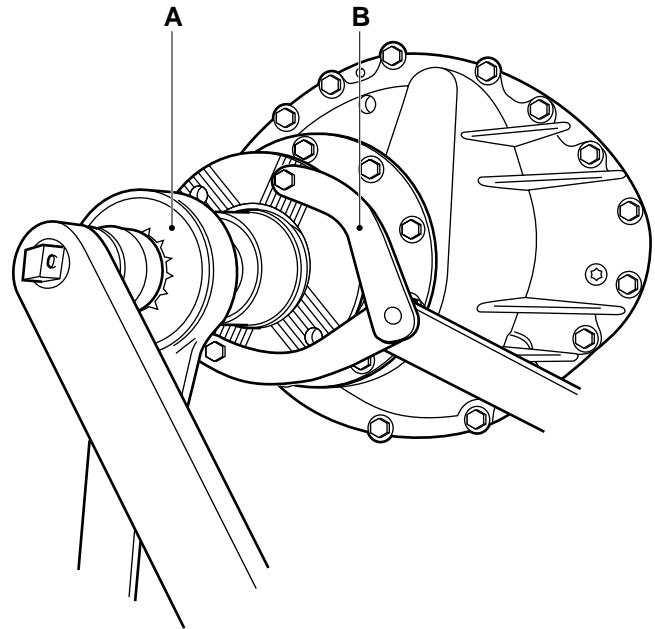

A8 00 357

**3.7 REMOVAL AND INSTALLATION, INPUT SHAFT PINION OIL SEAL**

**Removing the input shaft pinion oil seal**

1. Remove the drive flange.
2. Drill two holes into the seal and screw the special tool (B) (DAF no. 0484899) into the seal. Pull the oil seal from the pinion housing using the special tool (A) (DAF no. 0694928).

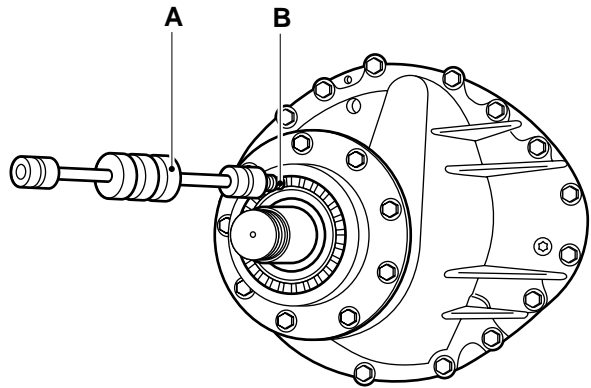

A8 00 360

**Installing the input shaft pinion oil seal**

1. Use the special tool (DAF no. 1240105) to fit the seal so that the inscription "outside" is pointed outwards.
2. Fit the drive flange.

**3.8 REMOVAL AND INSTALLATION, OUTPUT SHAFT PINION OIL SEAL**

**Removing the output shaft pinion oil seal**

1. Remove the drive flange.
2. Drill two holes into the seal and screw the special tool (B) (DAF no. 0484899) into the seal. Pull the oil seal from the pinion housing using the special tool (A) (DAF no. 0694928).

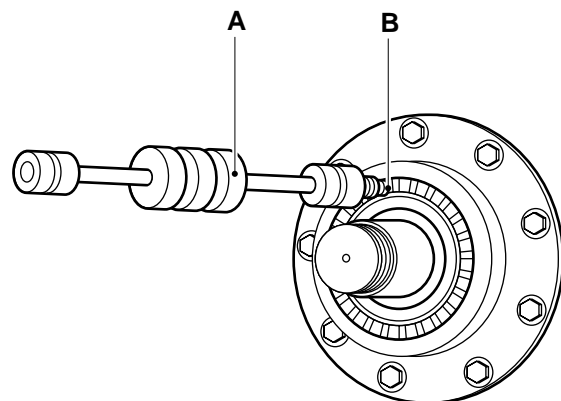

A8 00 426

**Installing the output shaft pinion oil seal**

1. Use a stamp (DAF no. 1240106) to fit the seal so that the inscription "outside" is pointed outwards.
2. Fit the drive flange.

### 3.9 REMOVAL AND INSTALLATION, DIFFERENTIAL

#### Removing the differential

1. Drain the oil from the differential, see "Draining and filling".
2. Remove the prop shaft from the drive flange.
3. Remove the axle shafts.
4. Remove the air connection for the differential lock.
5. Attach the differential securely to a lifting device.
6. Remove the attachment bolts from the differential.
7. Remove the differential from the axle housing using two jacking screws.

#### Installing the differential

1. Clean the mating surfaces of the axle housing and the differential housing. Re grind the mating faces lightly. Do not damage the mating faces in the process.
2. Clean and degrease the attachment bolts. Apply locking compound to the attachment bolts. See "Technical data".
3. Apply a thin, even layer of sealant to the mating surface and around the bolt holes of the axle housing, see "Technical data".
4. Fit the differential into the axle housing. Install the attachment bolts and tighten them evenly. Tighten the attachment bolts to the specified torque. See "Technical data".
5. Fit the air connection to the differential lock.
6. Fit the axle shafts.
7. Fit the prop shaft to the drive flange.
8. Fill the differential with oil, see "Draining and filling".

### 3.10 REMOVAL AND INSTALLATION, DIFFERENTIAL LOCK

#### Removing the differential lock

1. Remove the differential.



**Do not come near the selector sleeve when de-aerating the differential lock.**

2. Pressurise the air connection of the differential lock. Remove the special tool (A). Evenly de-aerate the differential lock.
3. Remove the attachment bolts (1) from the cylinder cover (2). Remove the cover.

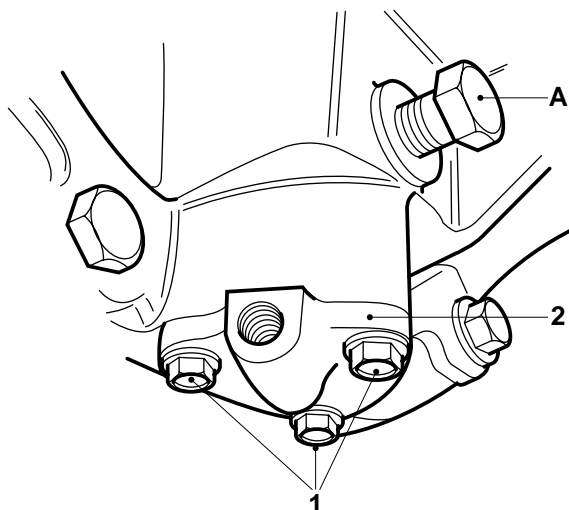

A8 00 353

4. Remove the piston (5).
5. Remove the shifting fork (3) and the sliding sleeve (1) with the spring (2).

#### Installing the differential lock

1. Fit the shifting fork (3) and the sliding sleeve (1) with the spring (2).

**Note:**

Make sure that the flat side (see arrow) of the shifting fork (3) points towards the piston (5).

2. Apply a small amount of oil to the piston (5) sealing ring (4).
3. Install the piston (5).
4. Install the cylinder cover and tighten the attachment bolts evenly. Tighten the attachment bolts to the specified tightening torque, see "Technical data".

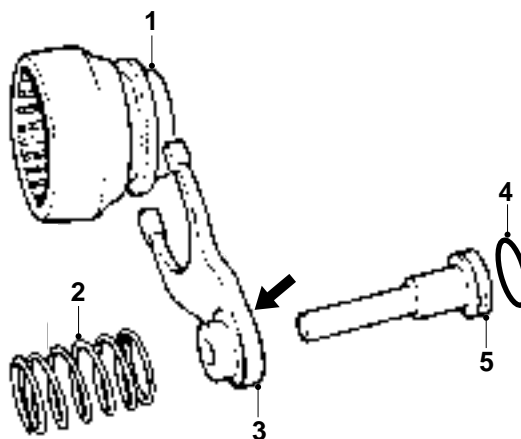

A8 00 354





**Do not come near the selector sleeve when de-aerating the differential lock.**

5. Pressurise the air connection of the differential lock. Fit special tool (A) (DAF no. 1329447), so that the differential lock is blocked.
6. Install the differential.

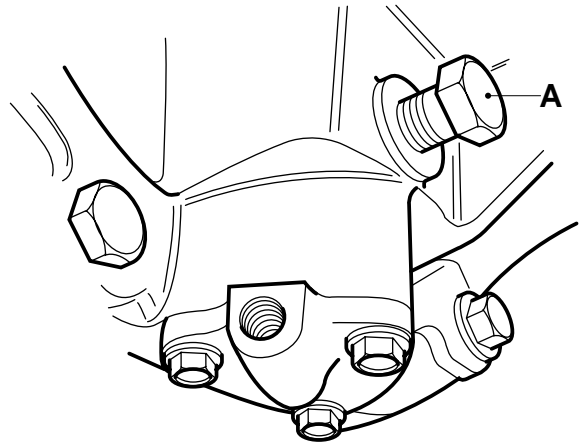

A8 00 346



## 4. DRAINING AND FILLING

### 4.1 DRAINING AND FILLING, HUB



To prevent skin injury, avoid unnecessary contact with the drained oil.

#### Draining the hub

1. Position the vehicle on a level surface.
2. Position the wheels so that the level check/filler plug (A) is at the underside.
3. Remove the level check/filler plug (A) and drain the oil.

#### Filling the hub

1. Position the vehicle on a level surface.
2. Position the wheels so that the level check/filler plug (A) is on the top.
3. Fill the hub with the specified quantity of oil. See "Technical data".
4. Check the oil level after approximately 5 minutes. See "Inspection and adjustment".
5. Fit the plug using the special Torx wrench (DAF no. 1329493) and tighten to the specified torque; see "Technical data".

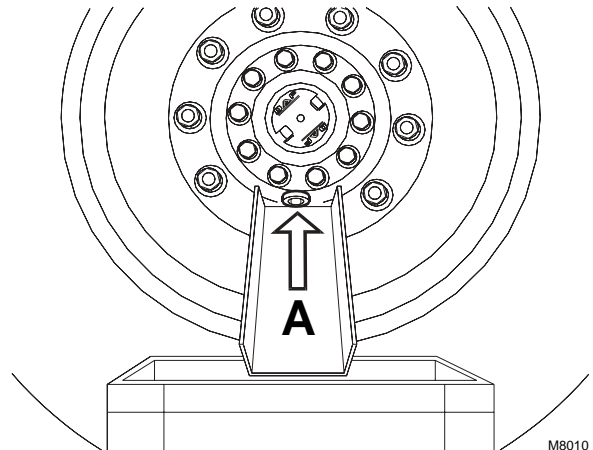

M8010

4.2 DRAINING AND FILLING, DIFFERENTIAL



To prevent skin injury, avoid unnecessary contact with the drained oil.

Draining the differential, first axle

1. Position the vehicle on a level surface.
2. Remove the level check/filler plug (A) and drain plug (B). Drain the oil.
3. Fit the drain plug (B) using the special Torx wrench (DAF no. 1329493) and tighten to the specified torque; see "Technical data".

Filling the differential

1. Fill the differential via the level check/filler plug (A) with the specified quantity of oil, see "Technical data".
2. Check the oil level after approx. 5 minutes. The oil level should now have reached the level check/filler opening. See "Inspection and adjustment".
3. Fit the level check/filler plug (A) using the special Torx wrench (DAF no. 1329493) and tighten to the specified torque; see "Technical data".

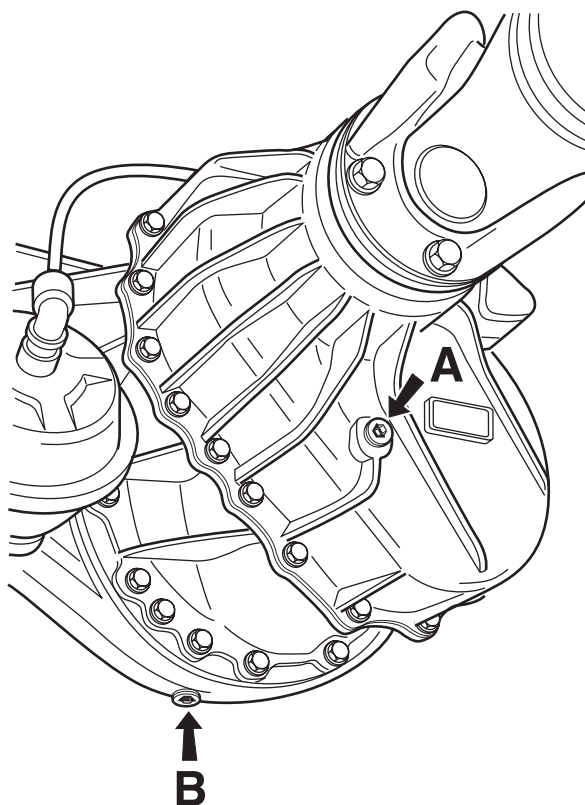

GO 00 268

Draining the differential, second axle

1. Position the vehicle on a level surface.
2. Remove the level check/filler plug (A) and drain plug (B). Drain the oil.
3. Fit the drain plug (B) using the special Torx wrench (DAF no. 1329493) and tighten to the specified torque; see "Technical data".

Filling the differential

1. Fill the differential via the level check/filler plug (A) with the specified quantity of oil, see "Technical data".
2. Check the oil level after approx. 5 minutes. The oil level should now have reached the level check/filler opening. See "Inspection and adjustment".
3. Fit the level check/filler plug (A) using the special Torx wrench (DAF no. 1329493) and tighten to the specified torque; see "Technical data".

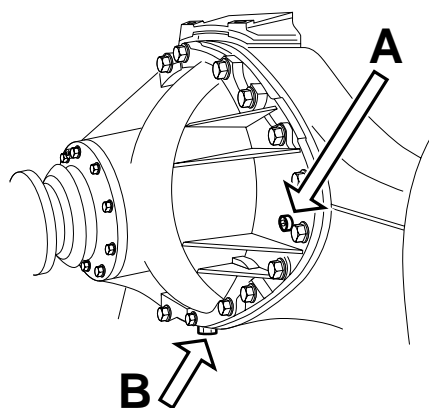

M8013

6

## CONTENTS

	Page	Date
<b>1. GENERAL</b> .....	1-1	200424
1.1 Description of 1355T, general .....	1-1	200424
1.2 Overview drawing, wheel hub .....	1-2	200424
<b>2. INSPECTION AND ADJUSTMENT</b> .....	2-1	200424
2.1 Inspection and adjustment, wheel bearing play .....	2-1	200424
2.2 Checking the hub oil levels .....	2-2	200424
2.3 Checking the differential oil level .....	2-3	200424
2.4 Checking the operation of the differential lock .....	2-4	200424
2.5 Checking the hub and wheel bearings .....	2-5	200424
2.6 Checking the wheel speed sensor ring .....	2-6	200424
<b>3. REMOVAL AND INSTALLATION</b> .....	3-1	200424
3.1 Removal and installation, entire rear axle .....	3-1	200424
3.2 Removal and installation, axle shafts .....	3-2	200424
3.3 Removal and installation, wheel hub .....	3-4	200424
3.4 Removal and installation, hub seal/wheel speed sensor ring unit .....	3-8	200424
3.5 Removal and installation, drive flange .....	3-10	200424
3.6 Removal and installation, input shaft pinion oil seal .....	3-11	200424
3.7 Removal and installation, output shaft pinion oil seal .....	3-12	200424
3.8 Removal and installation, differential .....	3-12	200424
3.9 Removal and installation, differential lock .....	3-14	200424
<b>4. DRAINING AND FILLING</b> .....	4-1	200424
4.1 Draining and filling, hub .....	4-1	200424
4.2 Draining and filling the differential .....	4-3	200424



## 1. GENERAL

### 1.1 DESCRIPTION OF 1355T, GENERAL

The 1355T tandem gear is a double-drive tandem gear with hub reduction. The rear-axle housing is of a very light but rigid construction. Due to this construction the banjo-housing cover is not welded to the axle housing but attached using bolts. These bolts, which run right through the axle housing, also attach the differential to the axle housing.

In the first axle the torque is divided over the first and second axle. To enable speed differences between the two axles, a so-called third differential is installed. If required, the differential can be locked. Via the axle shafts the torque is transferred to the wheel hubs, where, using a second reduction, the torque is used to drive the wheels.

1.2 OVERVIEW DRAWING, WHEEL HUB

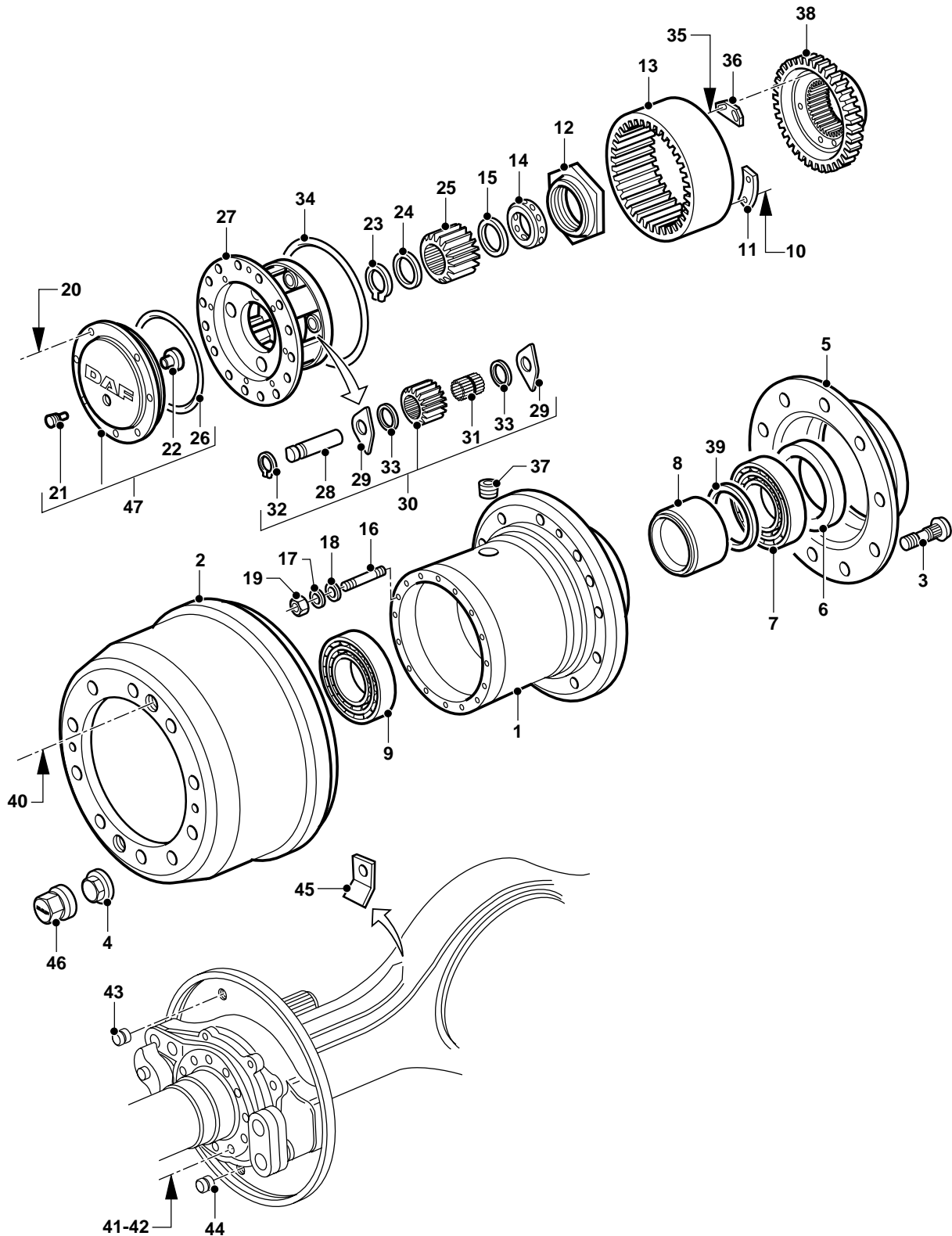

7

A8 00 349



1. Hub
2. Brake drum
3. Wheel stud
4. Nut
5. Grease retainer
6. Oil seal
7. Taper roller bearing
8. Bush
9. Taper roller bearing
10. Flange bolt
11. Attachment plate
12. Hub nut
13. Gear wheel
14. Thrust washer
15. Ring
16. Stud bolt
17. Spring washer
18. Sealing ring
19. Nut
20. Cap screw
21. Magnet plug
22. Yoke pin
23. Circlip
24. Ring
25. Gear wheel
26. O-ring
27. Support
28. Shaft
29. Shim
30. Hub
31. Needle bearing
32. Circlip
33. Shim
34. O-ring
35. Flange bolt
36. Locking plate
37. Plug
38. Holder
39. Shim
40. Cap screw
41. Flange bolt
42. Flange nut
43. Grommet
45. Bracket
46. Cap
47. Hub cap
48. Cover
49. Pin



## 2. INSPECTION AND ADJUSTMENT

### 2.1 INSPECTION AND ADJUSTMENT, WHEEL BEARING PLAY

1. Remove the wheel hub. See "Removal and installation".
2. Remove the hub seal. See "Removal and installation".
3. Fit the wheel hub without the hub seal. See "Removal and installation".
4. Turn a rope several times around the hub and attach it to a wheel stud. Pull the rope using a tensioner gauge and read off the force required to turn the hub at a constant speed. Compare the pressure reading with the technical data. See "Technical data".
5. The pre-load of the wheel bearings can be changed by removing or fitting spacers between the spacer sleeve and the inner wheel bearing. See "Removal and installation".

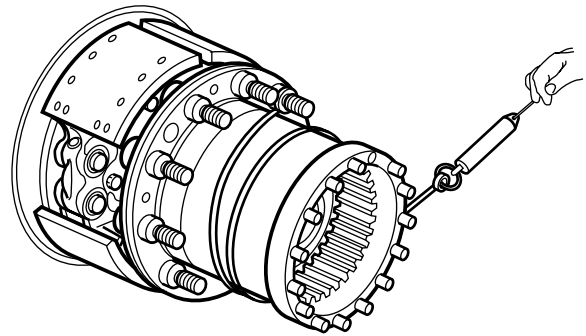

A800039

## 2.2 CHECKING THE HUB OIL LEVELS



To prevent skin injury, avoid unnecessary contact with the drained oil.

1. Position the vehicle on a level surface.
2. Position the wheels so that the arrow on the hub is pointing upwards.
3. Remove the level check plug (A). The oil level should have reached the opening.
4. Fit the level check plug (A) using the special Torx wrench (DAF no. 1329493) and tighten to the specified torque; see "Technical data".

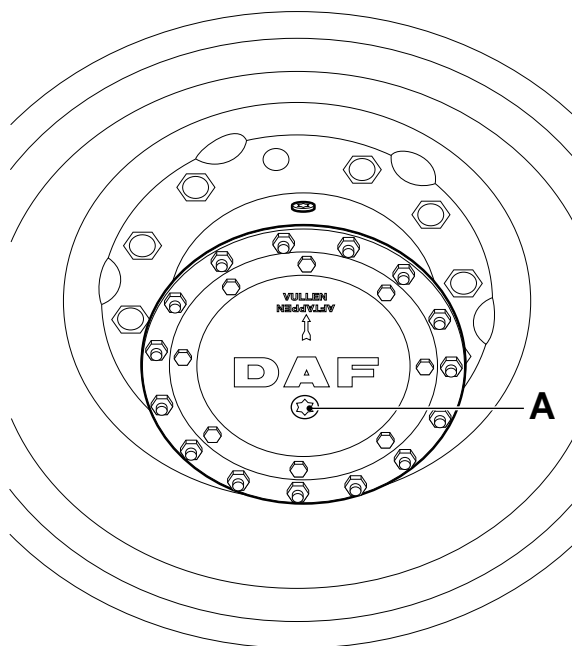

A8 00 365

### 2.3 CHECKING THE DIFFERENTIAL OIL LEVEL



To prevent skin injury, avoid unnecessary contact with the drained oil.

#### Checking the oil level, first axle

1. Position the vehicle on a level surface.
2. Remove the level check/filler plug (A). The oil level should have reached the level check/filler opening.
3. Fit the plug using the special Torx wrench (DAF no. 1329493) and tighten to the specified torque; see "Technical data".

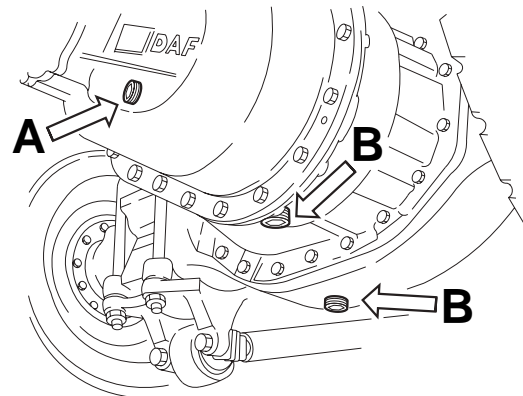

M8049

#### Checking the oil level, second axle

1. Position the vehicle on a level surface.
2. Remove the level check/filler plug (A). The oil level should have reached the level check/filler opening.
3. Fit the plug using the special Torx wrench (DAF no. 1329493) and tighten to the specified torque; see "Technical data".

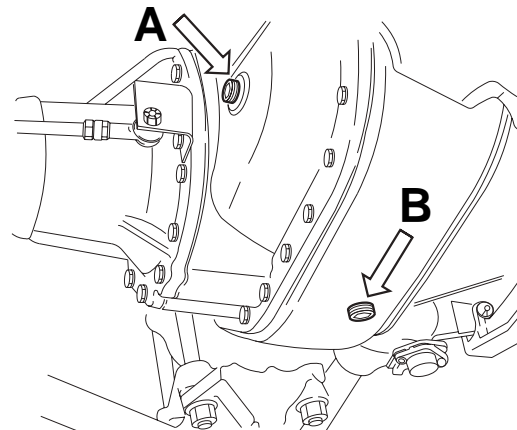

M8050

**2.4 CHECKING THE OPERATION OF THE DIFFERENTIAL LOCK**

1. Jack up the rear axle and support the axle on stands.
2. Bring the air system to operating pressure.
3. Engage the differential lock. The warning lamp should now come on.
4. Check that there is a "rigid" connection between the driven wheels.
5. Disengage the differential lock. The warning lamp should not light up and the "rigid" connection between the driven wheels should be broken.

## 2.5 CHECKING THE HUB AND WHEEL BEARINGS

1. Inspect the bearings for damage at the following points:
  - the roller bearing race,
  - the bearing cage,
  - the raceways of the inner and outer race.If damage is found, the entire bearing (inner race/bearing cage and outer race) should be replaced.
2. If the outer race of the bearing is loose in the hub or has turned in the hub, the hub should be replaced.
3. Check the axle journal screw thread, the bearing surfaces of the inner bearing races and the running surface of the seal for damage.
4. Check the wheel speed sensor ring for damage. Replace the ring at even the slightest trace of damage.

### 2.6 CHECKING THE WHEEL SPEED SENSOR RING

1. Remove the wheel hub. See "Removal and installation".
2. Check the sensor ring (1) for deposits. Special attention should be paid to deposits between the teeth of the sensor ring. Clean the sensor ring if necessary.
3. Check the sensor ring (1) for damage. Even the slightest damage can cause a failure. If necessary replace the sensor ring.
4. If possible, the sensor ring (1) should be checked for the maximum admissible axial end play. See "Technical data".
5. Check the sensor (2) for freedom of movement. If necessary, clean the sensor and apply new grease.

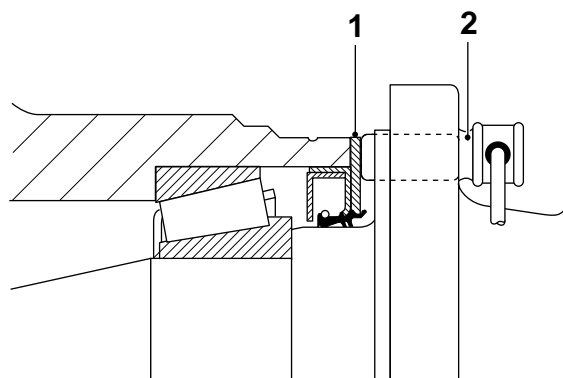

A8 00 347



### 3. REMOVAL AND INSTALLATION

#### 3.1 REMOVAL AND INSTALLATION, ENTIRE REAR AXLE

##### Removing the entire rear axle

1. Block the front wheels using chocks.
2. Slacken the central bolt of the spring-brake cylinder as much as possible.
3. Apply the parking brake.
4. Remove the air pipes and wiring.
5. Remove the prop shaft from the drive flange.
6. Loosen the shock absorbers on the bottom.
7. Loosen the control rod of the ALR valve.
8. Support the vehicle securely with stands under the chassis side members.
9. Remove the axle suspension/guide.  
Take precautionary measures to make sure that the axle does not tilt during removal of the axle suspension/guide.
10. If possible, the entire rear axle with wheels should be rolled from under the vehicle.

##### Installing the entire rear axle

1. Install the entire rear axle with wheels under the vehicle.
2. Fit the axle suspension/guide.  
Make sure that the torque-rod supports are fitted so that arrow **A** on the support points in the driving direction.
3. Fit the control rod of the ALR valve.

**Note:**

Check the setting of the ALR valve following installation of the rear axle.

4. Fit the shock absorbers (if applicable).
5. Fit the prop shaft to the drive flange.
6. Connect the electrical wiring and fit the air pipes.
7. Tighten the central bolt of the spring-brake cylinder.

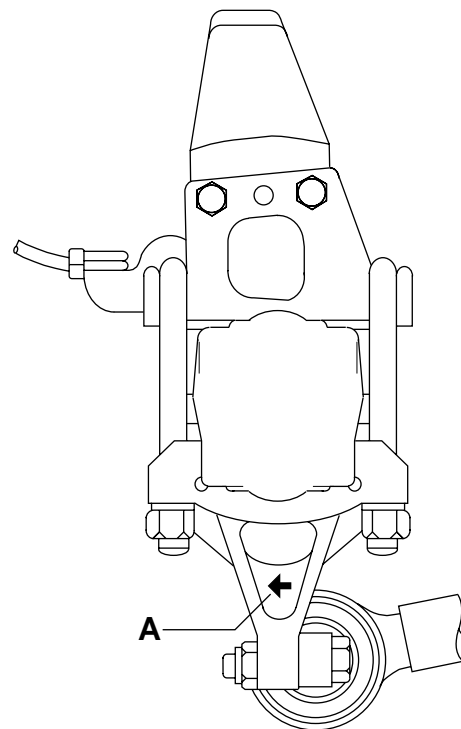

A800045

### 3.2 REMOVAL AND INSTALLATION, AXLE SHAFTS

#### Removing axle shafts

1. Jack up the rear axle and support the axle on stands.
2. Activate the differential lock and install the special tool (DAF no. 0694836) at the position of the switch.

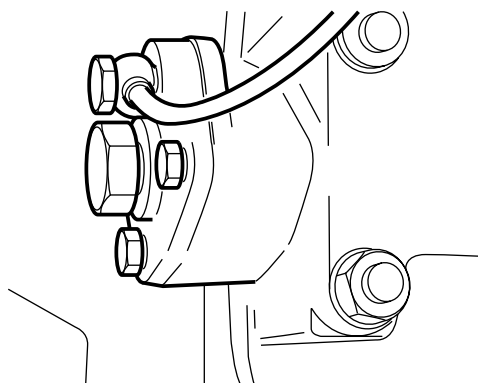

A800046

3. Drain the hub oil. See "Draining and filling".
4. Remove the attachment bolts from the hub cap and remove the hub cap.
5. Pull the axle shaft from the wheel hub.

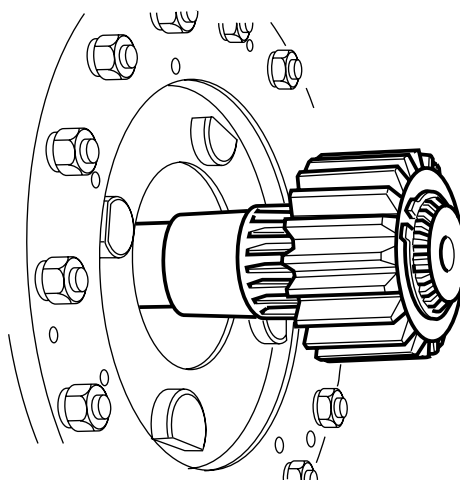

A800289

**Installing axle shafts**

1. Fit the axle shaft into the wheel hub.
2. Turn the planet-gear shafts so that the flat sides point outward.
3. Check the O-ring in the hub cap. If necessary, replace the O-ring and apply silicone grease.
4. Check the O-ring in the hub cap. If necessary, replace the O-ring. Apply silicone grease to the O-ring.
5. Install the spring assembly. Tighten the attachment bolts to the specified torque. See "Technical data".
6. Fill the hub with oil. See "Draining and filling".
7. Remove the special tool from the differential lock and fit the switch again.

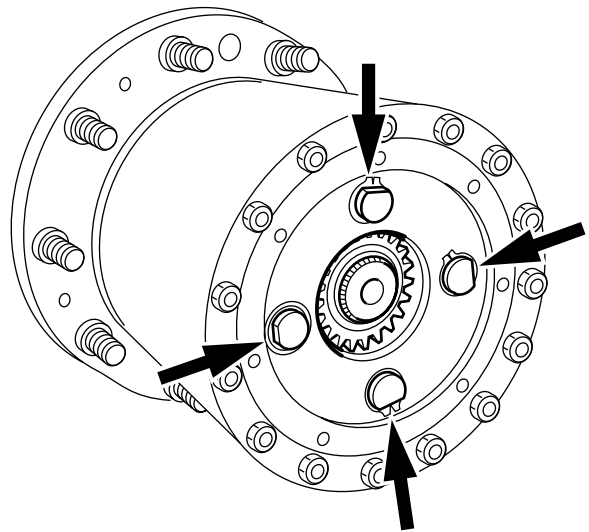

A800040

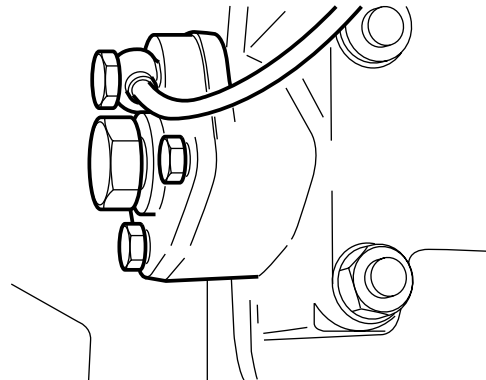

A800046

### 3.3 REMOVAL AND INSTALLATION, WHEEL HUB

#### Removing the wheel hub

1. Jack up the rear axle and support the axle on stands.
2. Remove the wheels.
3. Release the brakes and remove the brake drum.
4. Mark the hub at the semicircular hole in the cover.
5. Drain the oil. See "Draining and filling".
6. Remove the hub cap.
7. Remove the axle shaft.

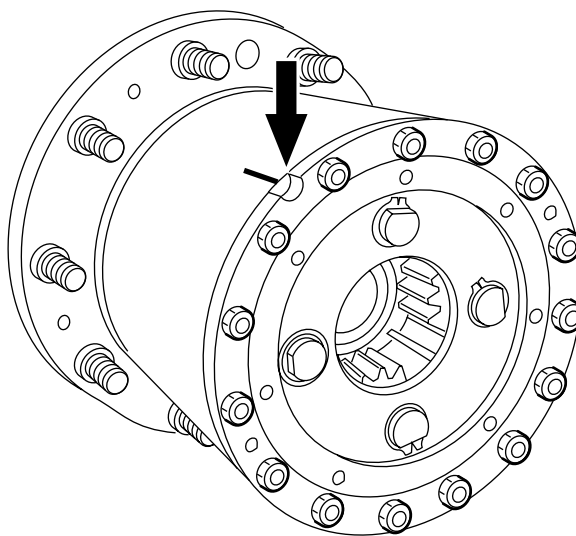

A800290

8. Remove the attachment nuts and tapered spring washers. Remove the planet-gear set from the hub using three jacking screws.

**Note:**

Make sure that the planet-gear set is put down with the circlips facing upward. This will prevent the pins from falling out.

9. Remove the thrust washer from the axle journal.
10. Remove the attachment bolts from the locking plate and remove the locking plate.

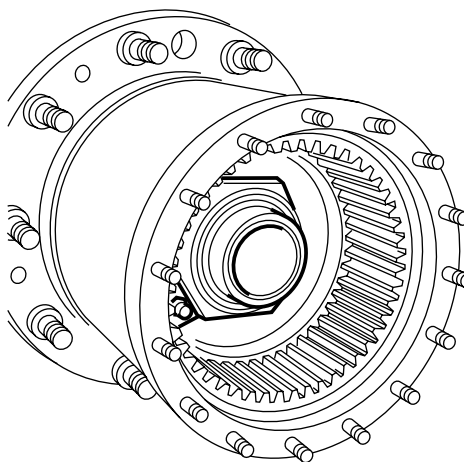

A800107

11. Remove the hub nut using special tool (DAF no. 0535705) and a torque amplifier (ratio 1 : 5).
12. Support the hub and pull it from the axle journal. The annular-gear carrier with the annular gear, the bearings and the spacer sleeve with spacer rings will be removed at the same time.
13. Remove the annular-gear carrier with the annular gear from the hub.

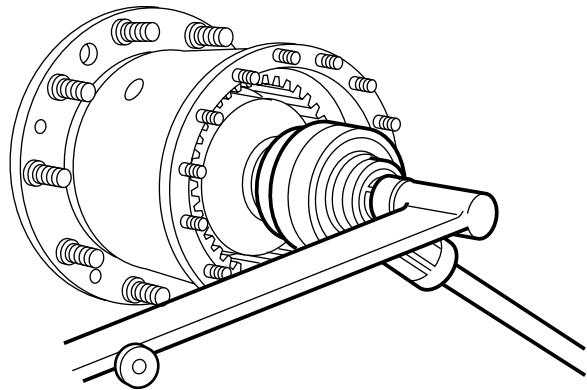

A800038

### Installing the wheel hub

#### Note:

If you have not replaced the wheel bearings and intend to reuse the original spacer sleeve with spacer rings, you need not readjust the wheel bearing pre-load.

If the wheel bearings have been replaced, the wheel bearing pre-load should be re-adjusted, see chapter "Inspection and adjustment". You must adjust the wheel bearing pre-load before fitting the hub seal.

1. Replace the hub seal.
2. Check the components for signs of wear and/or damage.
3. Replace the O-rings.
4. Apply oil to the wheel bearings.
5. Fit the hub on the axle journal.
6. Fit the original spacer sleeve and spacer rings.
7. Fit the inner race of the outer wheel bearing on the axle journal.
8. Fit the annular-gear carrier with the annular gear into the hub and on the splines of the axle journal.

9. Fit the hub nut and tighten it using special tool (DAF no. 0535705) and a torque amplifier (ratio 1 : 5). Tighten the hub nut to the specified tightening torque, see "Technical data". Turn the hub nut while tightening it.

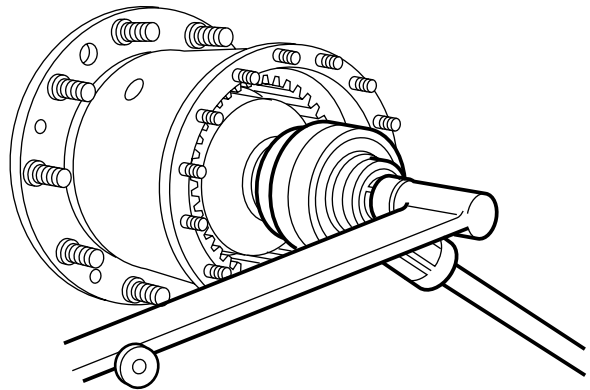

A800038

10. Fit the locking plate. Apply locking compound to the attachment bolts and tighten them to the specified torque. See "Technical data".

11. Install the thrust washer.

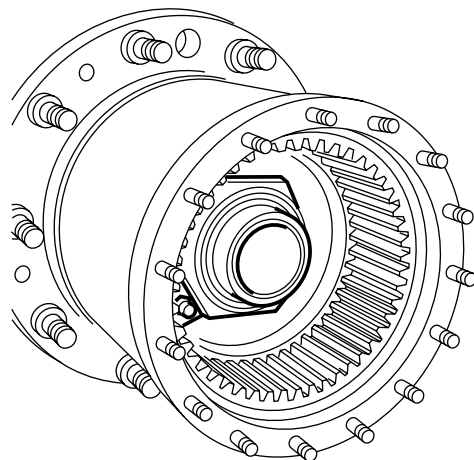

A800107

12. Fit the planet-wheel set in its original position in the hub (watch the markings).

13. Install the tapered spring washers and tighten them to the specified torque. See "Technical data".

14. Fit the axle shaft.

15. Check the O-ring in the hub cap. If necessary, replace the O-ring. Apply silicone grease to the O-ring.

16. Install the spring assembly. Tighten the attachment bolts to the specified torque. See "Technical data".

17. Fill the hub with oil. See "Draining and filling".

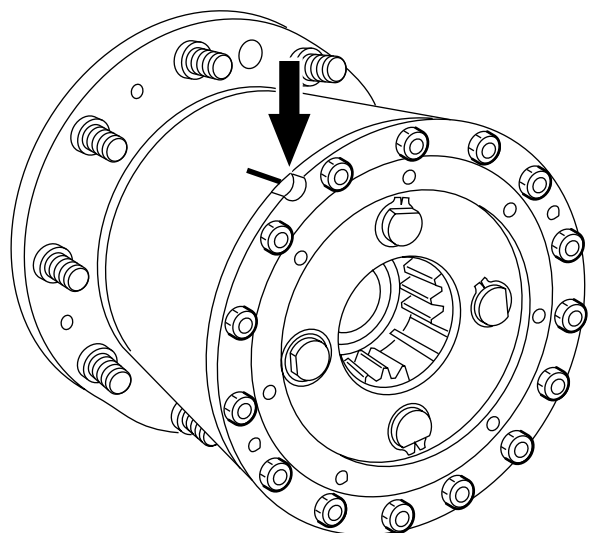

A800290

18. Press the sensor (2) against the sensor ring (1).  
While the vehicle is being driven, the air gap between the sensor and the sensor ring is adjusted automatically.

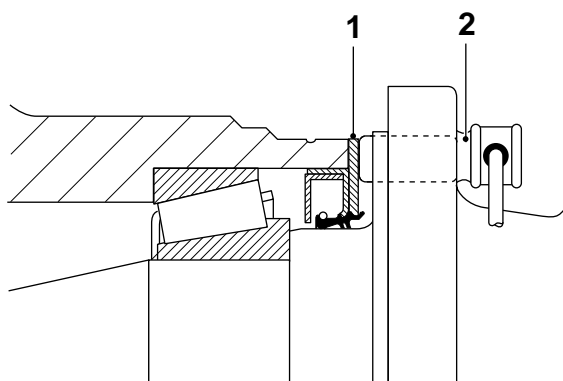

A8 00 347

**3.4 REMOVAL AND INSTALLATION, HUB SEAL/WHEEL SPEED SENSOR RING UNIT**

**Removing the hub seal/wheel speed sensor ring**

1. Remove the hub from the axle journal.
2. Fit special tool (3) (DAF no. 1329411) to the impact puller (2), special tool (DAF no. 0694928). Fit the special tool (3) behind the seal/sensor ring (1). Use the impact puller (2) to pull the seal/sensor ring (1) evenly from the hub. Once removed, the seal/sensor ring cannot be reused.

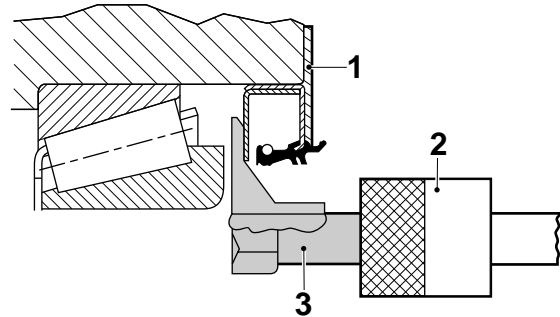

S7 00 424

**Installing the hub seal/wheel speed sensor ring**

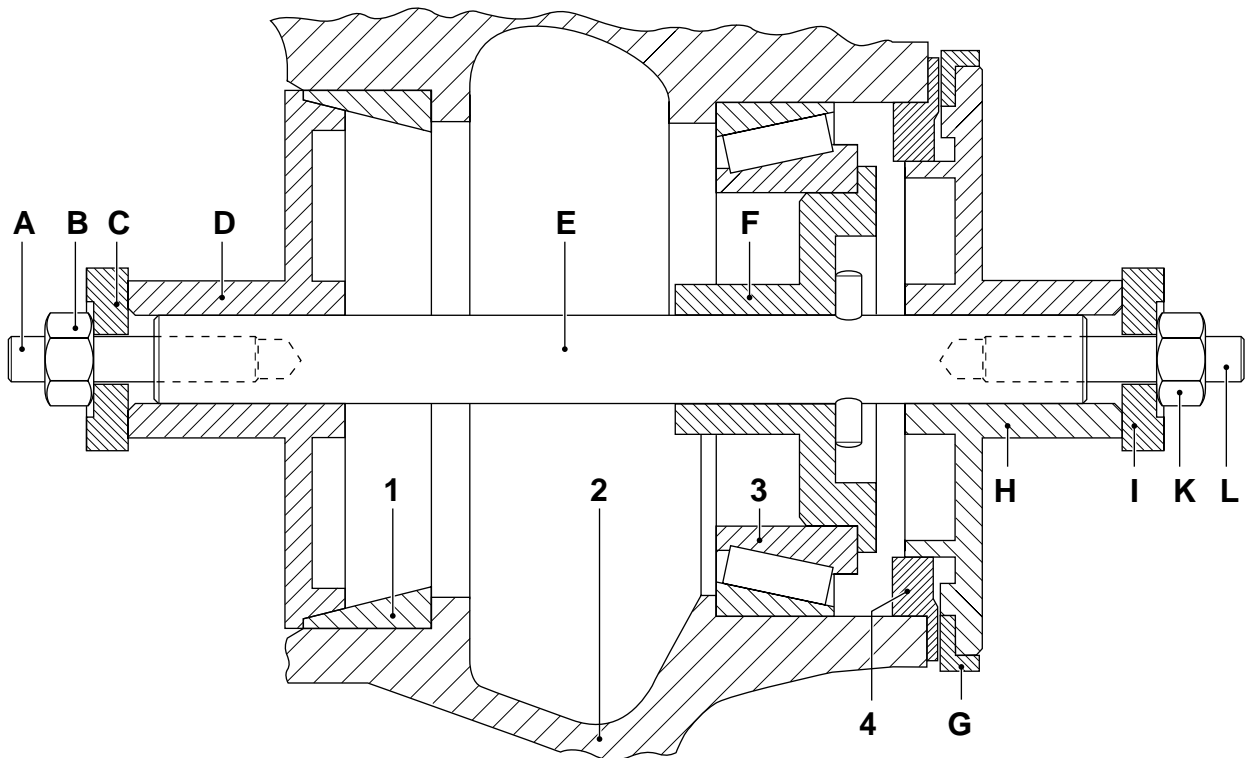

S7 00 405

1. Check the recess for the seal/sensor ring (4) in the hub (2) for damage.
2. Use the special tool (DAF no. 1240036) to install the seal/sensor ring (4).

7



3. Assemble the special tool: turn the threaded ends (A) and (L) into the centring spindle (E). Assemble the short stud (L) on the side where the pin has been fitted into the centring spindle (E).
4. Slide the appropriate centring flange (F) over the centring spindle (E).
5. Install the inner wheel bearing (3). Insert the centring spindle (E) together with the centring flange (F) into the hub (2).
6. Press the centring flange (F) into the inner wheel bearing (3).
7. Slide the appropriate centring flange (D) on the centring spindle (E).
8. Fit the retaining plate (C) and the nut (B) on the centring spindle (E).
9. Align the centring flange (D) on the outer race of the outer wheel bearing and hand-tighten nut (B) (max. 20 Nm). The centring spindle (E) must be installed in the hub (2) free of play.
10. Fit the ring (G) on the draw-in flange (H).
11. Position the seal/sensor ring (4) in front of the hub (2). Slide the draw-in flange (H) with the washer (G) over the centring spindle (E) against the seal/sensor ring (4).
12. Fit the retaining plate (I) and the nut (K).
13. Press the seal/sensor ring (4) evenly into the hub (2) using nut (K), until the sensor ring abuts the hub (2).
14. Remove the special tool.
15. Apply grease to the sealing lips of the seal/sensor ring (4).
16. Fit the hub on the axle journal.

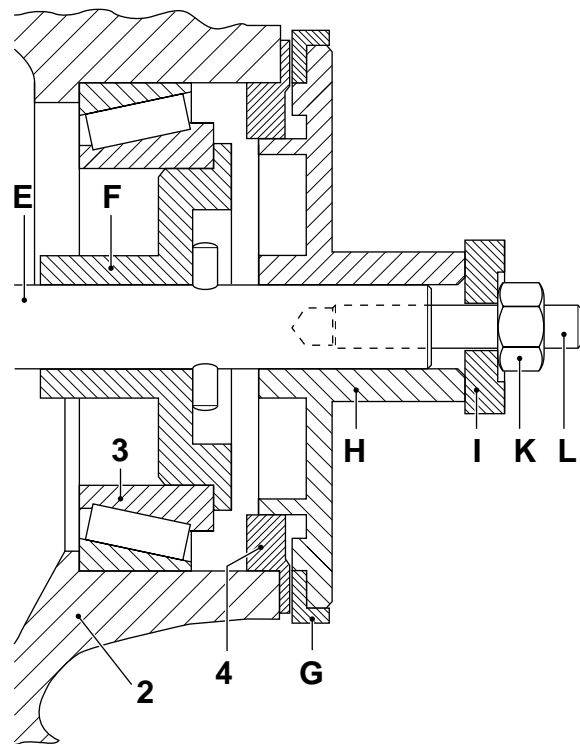

S7 00 411

### 3.5 REMOVAL AND INSTALLATION, DRIVE FLANGE

#### Removing the drive flange

1. Remove the prop shaft from the drive flange.
2. Fit the special tool (B) (DAF no. 0484977) on the drive flange to prevent it from rotating. Remove the drive flange nut using a torque amplifier (A).
3. Remove the drive flange. If necessary, use a puller.

#### Installing the drive flange

1. Before installation check the drive flange along the oil-seal running surface for grooves and/or sharp edges. If required, replace the drive flange.
2. Fit the drive flange.
3. Apply a small amount of oil to the abutting surface of the drive-flange nut.
4. Apply locking compound to the screw thread. See "Technical data".
5. Fit the special tool (B) (DAF no. 0484977) on the drive flange to prevent the flange from rotating. Fit the drive-flange nut. Use a torque amplifier (A) to tighten the drive-flange nut to the specified tightening torque, see "Technical data".
6. Fit the prop shaft to the drive flange.

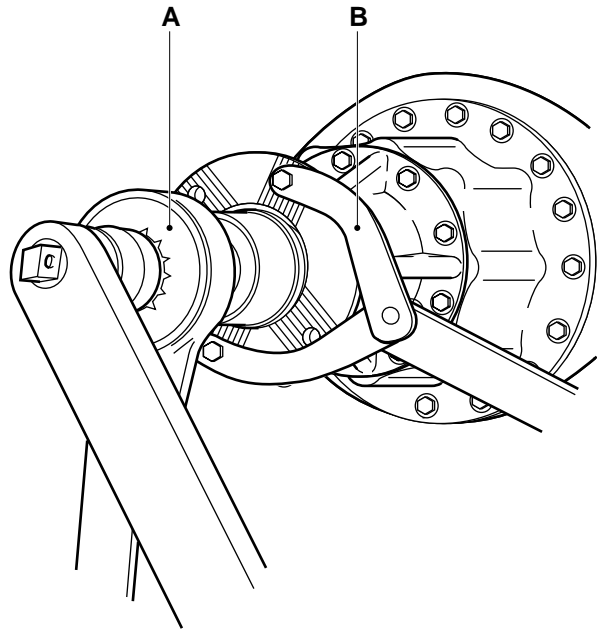

A8 00 358

### 3.6 REMOVAL AND INSTALLATION, INPUT SHAFT PINION OIL SEAL

#### Removing the input-shaft seal

1. Remove the drive flange.
2. Remove the attachment bolts from the bearing-house cover and remove the bearing-house cover.
3. Remove the seal from the bearing-house cover.

#### Installing the input-shaft oil seal

1. Clean the mating surfaces of the bearing-house cover and the differential housing.
2. Lightly grease the bearing cover and, using a stamp (DAF no. 1240089), install the oil seal so that the inscription "outside" points outward.
3. Apply a thin film of the specified sealant on the surface to which the bearing-house cover is fitted, see "Technical data".
4. Fit the bearing-house cover. Tighten the attachment bolts to the specified torque. See "Technical data".
5. Fit the drive flange.

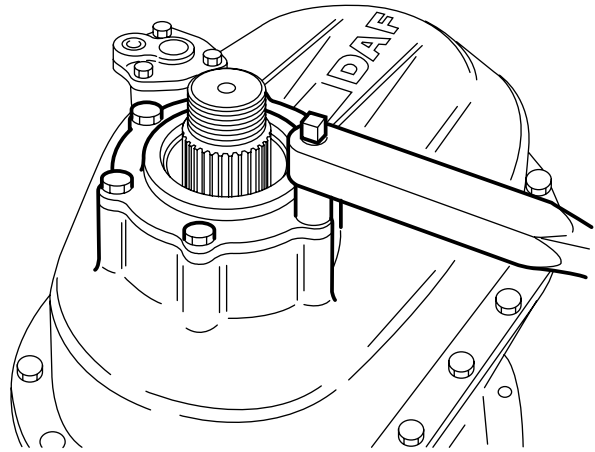

A800053

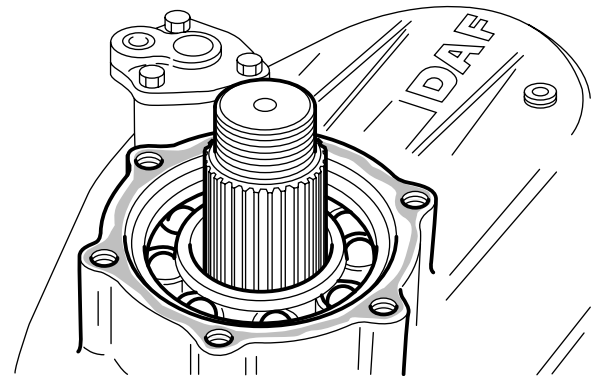

A800055

**3.7 REMOVAL AND INSTALLATION, OUTPUT SHAFT PINION OIL SEAL**

**Removing the output shaft pinion oil seal**

1. Remove the drive flange.
2. Drill two holes into the seal and screw the special tool (B) (DAF no. 0484899) into the seal. Pull the oil seal from the pinion housing using the special tool (A) (DAF no. 0694928).

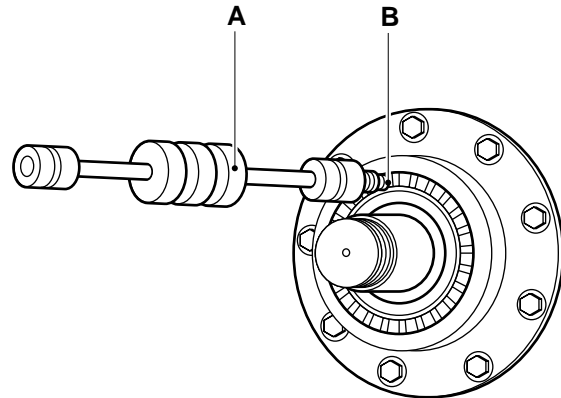

A8 00 426

**Installing the output shaft pinion oil seal**

1. Use a stamp (DAF no. 1240106) to fit the seal so that the inscription "outside" is pointed outwards.
2. Fit the drive flange.

**3.8 REMOVAL AND INSTALLATION, DIFFERENTIAL**

**Removing the differential**

1. Drain the oil from the differential and the hubs.
2. Remove the prop shaft from the drive flange.
3. Remove the axle shafts.
4. Remove the air connection for the differential lock.
5. Attach the differential securely to a lifting device.
6. Remove the nuts from the attachment bolts (B). These long bolts run through the differential housing.
7. Remove the two attachment bolts (A) from the differential.
8. Remove the differential from the axle housing.

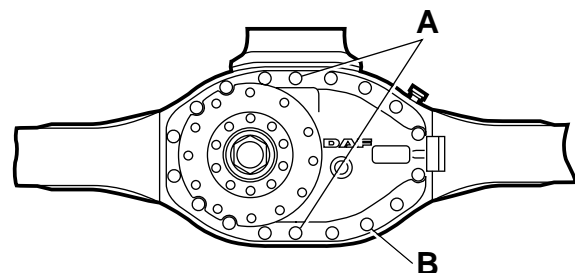

A800047

**Installing the differential**

1. Clean the mating surfaces of the banjo housing and the differential housing. Do not damage the mating faces in the process.
2. Clean the nut and bolt flanges of the through bolts.
3. Apply a thin, even film of the specified sealant on the mating surface of the banjo housing, see "Technical data". Make sure that the sealant is applied correctly around the bolt holes.
4. Apply the specified sealant to the nut and bolt flanges of the through bolts, see "Technical data".
5. Apply locking compound to the threads. See "Technical data".
6. Fit the differential into the banjo housing.
7. Tighten the bolts and nuts to the specified tightening torque, see "Technical data".
8. Fit the air connection to the differential lock.
9. Fit the axle shafts.
10. Fit the prop shaft to the drive flange.
11. Fill the differential and the hubs with oil.

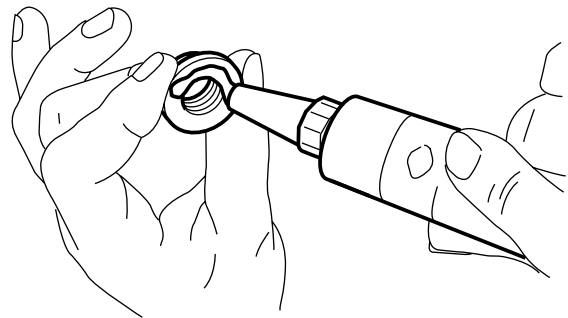

A800051

3.9 REMOVAL AND INSTALLATION, DIFFERENTIAL LOCK

Removing the differential lock

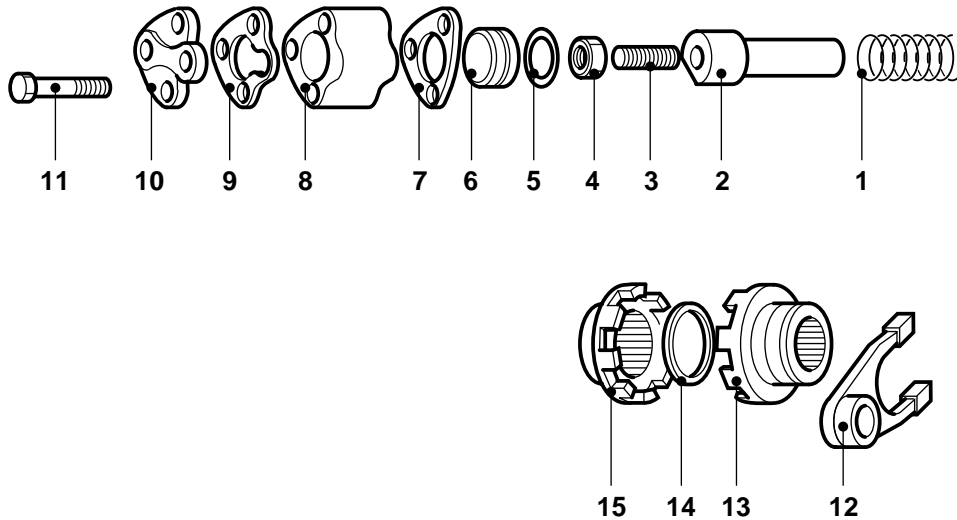

A800226

1. Remove the differential.
2. Remove the special tool (DAF no. 0694836).
3. Remove the attachment bolts (11).
4. Remove the cover (10) together with the gasket (9).
5. Remove the cylinder housing (8) and gasket (7). The piston (6) with sealing ring (5) will come free.
6. Remove the selector shaft (2), the shifting fork (12), the clutch body (13) and the pressure spring (1).
7. Remove the selector sleeve (15).

## Installing the differential lock

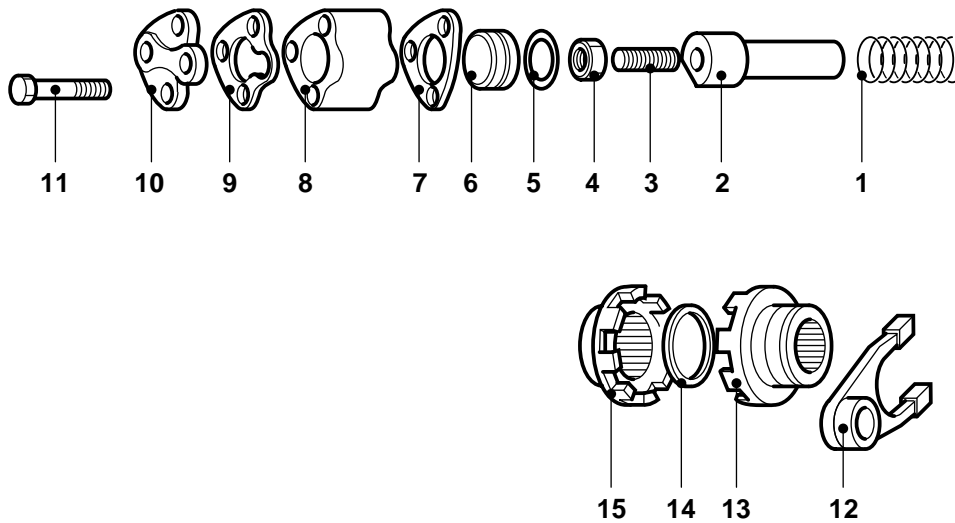

A800226

1. Fit the selector sleeve (15)
2. Fit the selector shaft (2) with the shifting fork (12) and the clutch body (13) to the differential housing. Make sure that the tapered edge of the shifting fork is flush against the shoulder of the axle. Do not fit the pressure spring yet (1).
3. Unscrew the adjusting bolt (3) on the selector shaft (2) so far that when the claws fully engage, the top of the adjusting screw remains under the mating surface of the differential housing with the specified value. See "Technical data".

**Note:**

The differential lock must be adjusted such that the claws of the clutch body and synchroniser shaft fully engage. In addition, the shifting fork may not grind against the edge of the groove in the clutch body. It is especially important that the play between crown wheel/pinion gear is properly adjusted.

4. Fit the pressure spring (1) between the differential housing and the shifting fork (12).
5. Fit the sealing ring (5) to the piston of the differential lock and lightly oil the piston.
6. Fit the piston (6) into the cylinder.
7. Fit the air connection at the correct position. The air connection lip must point to the top of the differential in the direction of the input shaft.

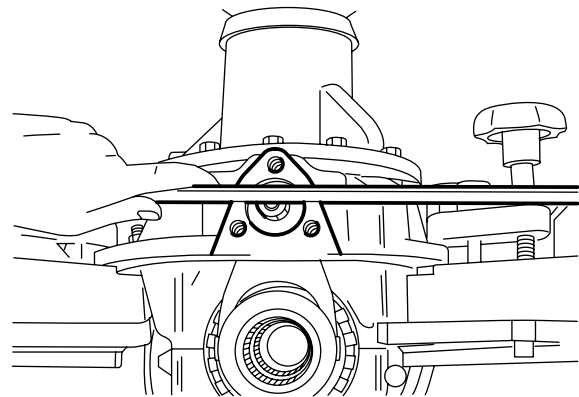

A800077

8. Fit the locking cylinder (8) with the cover (10) and the two gaskets (7) and (9) to the differential housing. Tighten the attachment bolts (11) to the specified torque. See "Technical data".
9. Fit the special tool (DAF no. 0694836) so that the differential lock is blocked.
10. Install the differential.
11. Fit the air connection to the differential lock.
12. Remove the special tool.
13. Fit the switch with the spring washer and electrical connection.



## 4. DRAINING AND FILLING

### 4.1 DRAINING AND FILLING, HUB



To prevent skin injury, avoid unnecessary contact with the drained oil.

#### Draining the hub

1. Position the vehicle on a level surface.
2. Position the wheels in such a way that the oil drain/filler plug (A) is on the underside.
3. Remove the oil level check plug (B) and oil drain/filler plug (A).
4. Drain the oil and let the oil leak out of the hub.

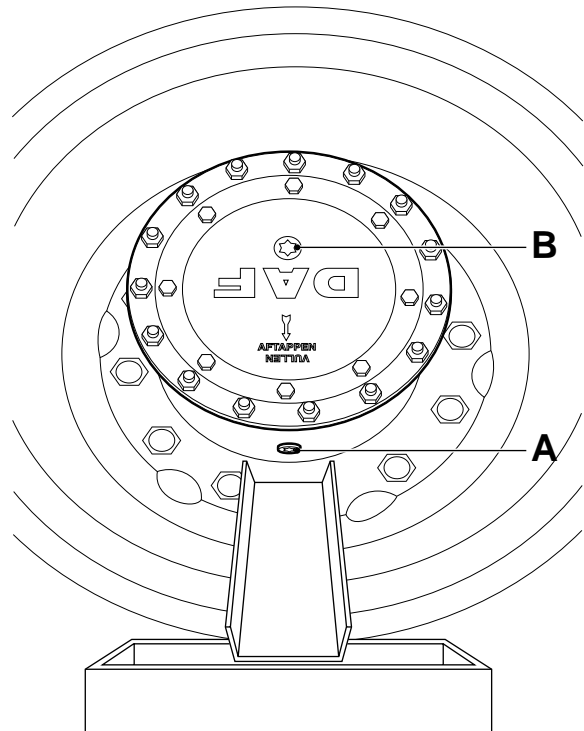

A8 00 363

### Filling the hub

1. Position the wheels in such a way that the oil drain/filler plug (A) is at the top.
2. Fill the hub with the specified quantity of oil. See "Technical data".
3. Check the oil level after approximately 5 minutes. See "Inspection and adjustment".
4. Fit the plugs using the special Torx wrench (DAF no. 1329493) and tighten to the specified torque; see "Technical data".

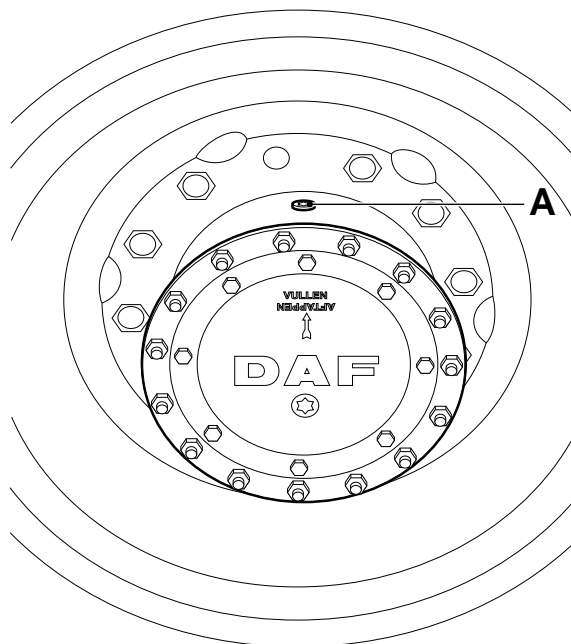

A8 00 364

## 4.2 DRAINING AND FILLING THE DIFFERENTIAL



To prevent skin injury, avoid unnecessary contact with the drained oil.

### Draining the differential, first axle

1. Position the vehicle on a level surface.
2. Remove the drain plugs (B) and drain the oil. Let all the oil leak out of the differential.
3. Fit the plugs using the special Torx wrench (DAF no. 1329493) and tighten to the specified torque; see "Technical data".

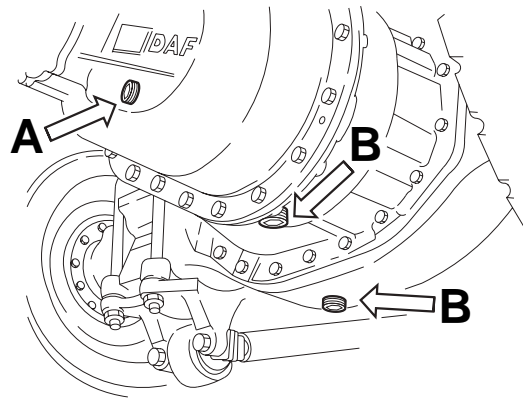

M8049

### Filling the differential, first axle

1. Remove the level check/filler plug (A) and fill the differential with the specified quantity of oil. See "Technical data".
2. Check the oil level after approximately 5 minutes. See "Inspection and adjustment".
3. Fit the plug using the special Torx wrench (DAF no. 1329493) and tighten to the specified torque; see "Technical data".

### Draining the differential, second axle

1. Position the vehicle on a level surface.
2. Remove the drain plug (B) and drain the oil. Let all the oil leak out of the differential.
3. Fit the plug using the special Torx wrench (DAF no. 1329493) and tighten to the specified torque; see "Technical data".

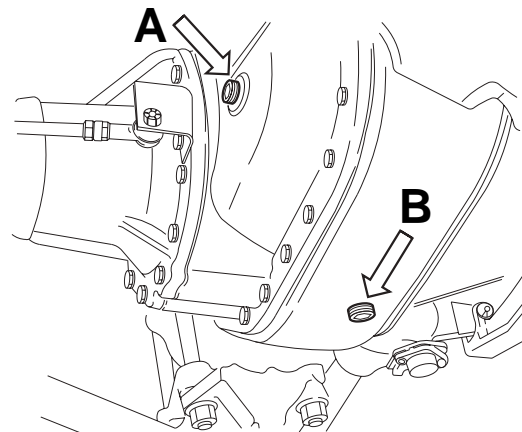

M8050

### Filling the differential, second axle

1. Remove the level check/filler plug (A) and fill the differential with the specified quantity of oil. See "Technical data".
2. Check the oil level after approximately 5 minutes. See "Inspection and adjustment".
3. Fit the plug using the special Torx wrench (DAF no. 1329493) and tighten to the specified torque; see "Technical data".



## CONTENTS

	Page	Date
<b>1. GENERAL</b> .....	1-1	200424
1.1 Description of 09N075/09N220 trailing axle .....	1-1	200424
1.2 Overview drawing, 09N075 trailing axle hub .....	1-2	200424
1.3 Overview drawing, 09N220 trailing axle hub .....	1-3	200424
1.4 Overview drawing, trailing-axle yoke attachment .....	1-4	200424
<b>2. REMOVAL AND INSTALLATION</b> .....	2-1	200424
2.1 Removal and installation, wheel hub unit (09N075 trailing axle) .....	2-1	200424
2.2 Removal and installation, wheel hub (09N220 trailing axle) .....	2-4	200424
2.3 Removal and installation, trailing axle .....	2-7	200424
2.4 Removal and installation, trailing-axle yoke. ....	2-10	200424



## 1. GENERAL

### 1.1 DESCRIPTION OF 09N075/09N220 TRAILING AXLE

Vehicles with a trailing axle are typically equipped with a driven axle followed by a non-driven axle, i.e. the trailing axle. If the axle load is so low that this load can be carried by the driven axle only, the trailing axle can be lifted.

The advantage of this is that tyres, brakes and fuel are saved.

#### 09N075 trailing axle

The 09N075 trailing axle is an air-suspended rigid axle with a pneumatic lifting gear.

#### 09N220 trailing axle

The 09N220 trailing axle can be either air-suspended or leaf-sprung.

The air-suspended trailing axle is a rigid axle with a pneumatic lifting gear.

With a leaf-sprung trailing axle, the driven rear axle is suspended by spring assemblies which are connected (hinged) at the front. On the other side the spring assemblies are connected to the trailing-axle wheel yoke using shackles. The lever effect of the wheel yoke makes sure that the trailing axle is also suspended. The trailing axle may or may not be equipped with a hydraulic lifting gear.

#### Wheel hub

The wheel hub, wheel bearings and hub oil seal form a unit, also called the wheel hub unit (3). The wheel bearings are a compact version.

The thrust washer (2) installed between the hub nut (1) and wheel bearing, is fitted with two straight surfaces on the inside to prevent the washer from turning. This is to prevent the hub nut (1) from loosening in case of wheel bearing problems. The hub nut (1) is of the self-locking type. The nut is locked by bending the lips on the hub nut outward.

The wheel bearings of the wheel hub unit are greased and are maintenance free.

The correct wheel bearing pre-load is achieved by installing the hub nut as specified.

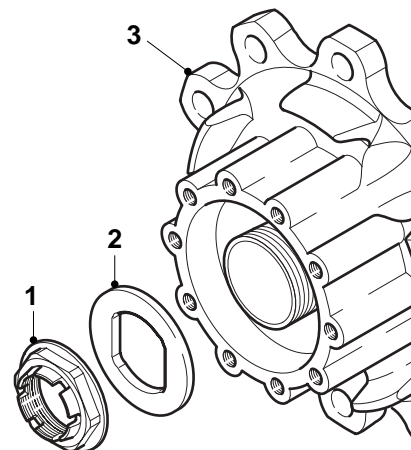

A8 00 356

## 1.2 OVERVIEW DRAWING, 09N075 TRAILING AXLE HUB

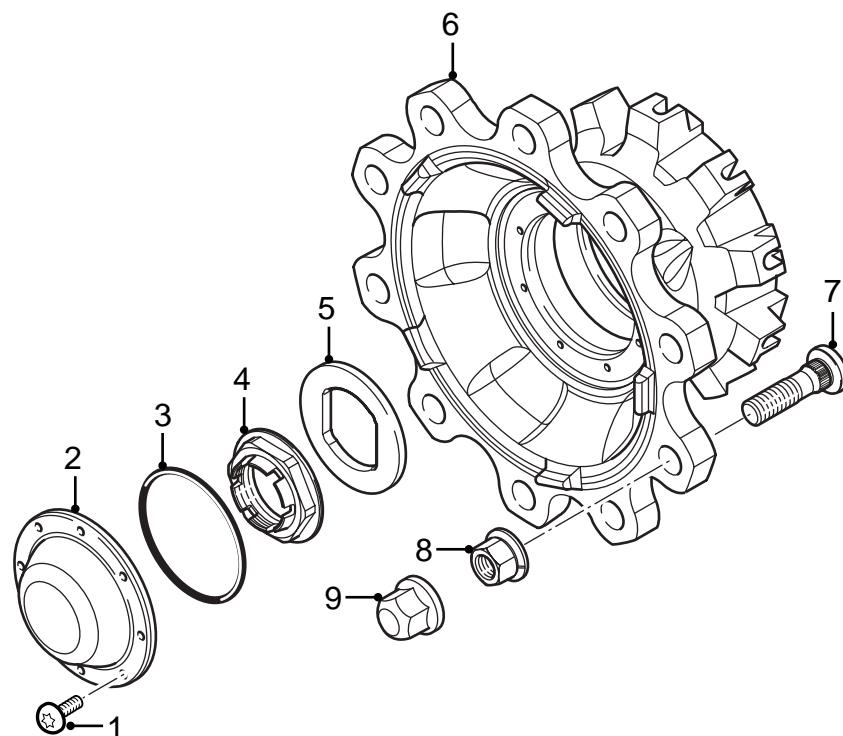

A8 00 404

1. Attachment bolt
2. Hub cap
3. O-ring
4. Hub nut
5. Thrust washer
6. Wheel hub unit
7. Wheel stud
8. Wheel nut
9. Wheel nut cap



## 1.3 OVERVIEW DRAWING, 09N220 TRAILING AXLE HUB

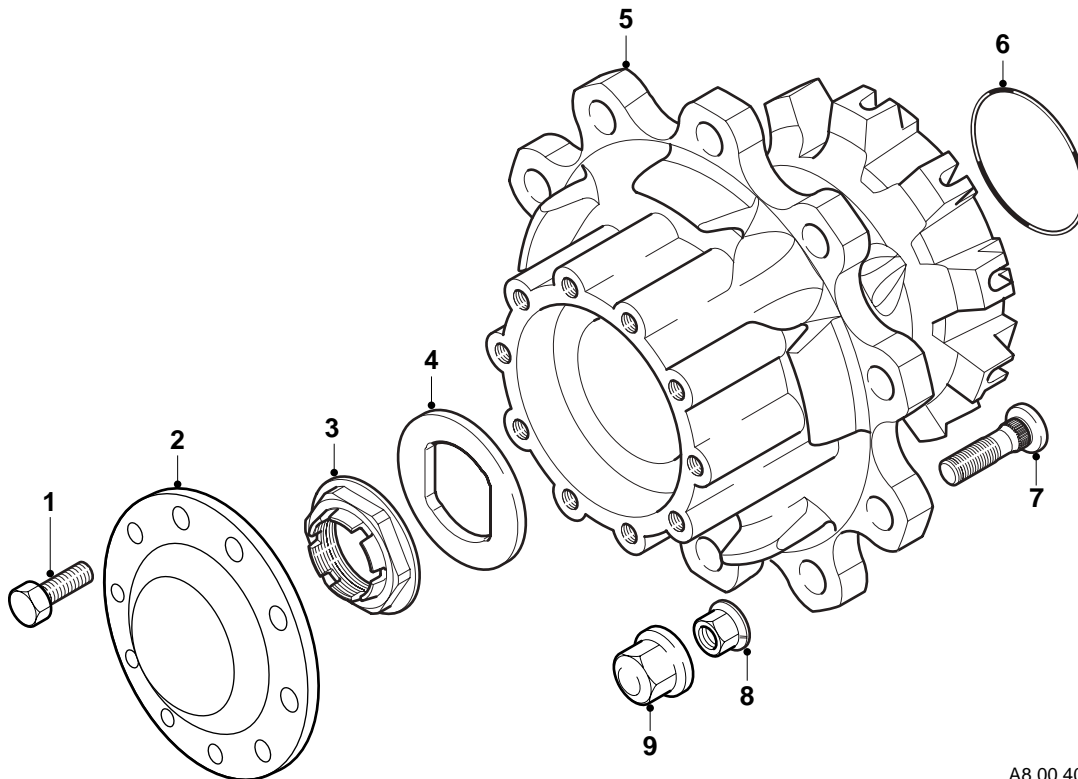

A8 00 403

1. Attachment bolt
2. Hub cap
3. Hub nut
4. Thrust washer
5. Wheel hub unit
6. O-ring
7. Wheel stud
8. Wheel nut
9. Wheel nut cap

1.4 OVERVIEW DRAWING, TRAILING-AXLE YOKE ATTACHMENT

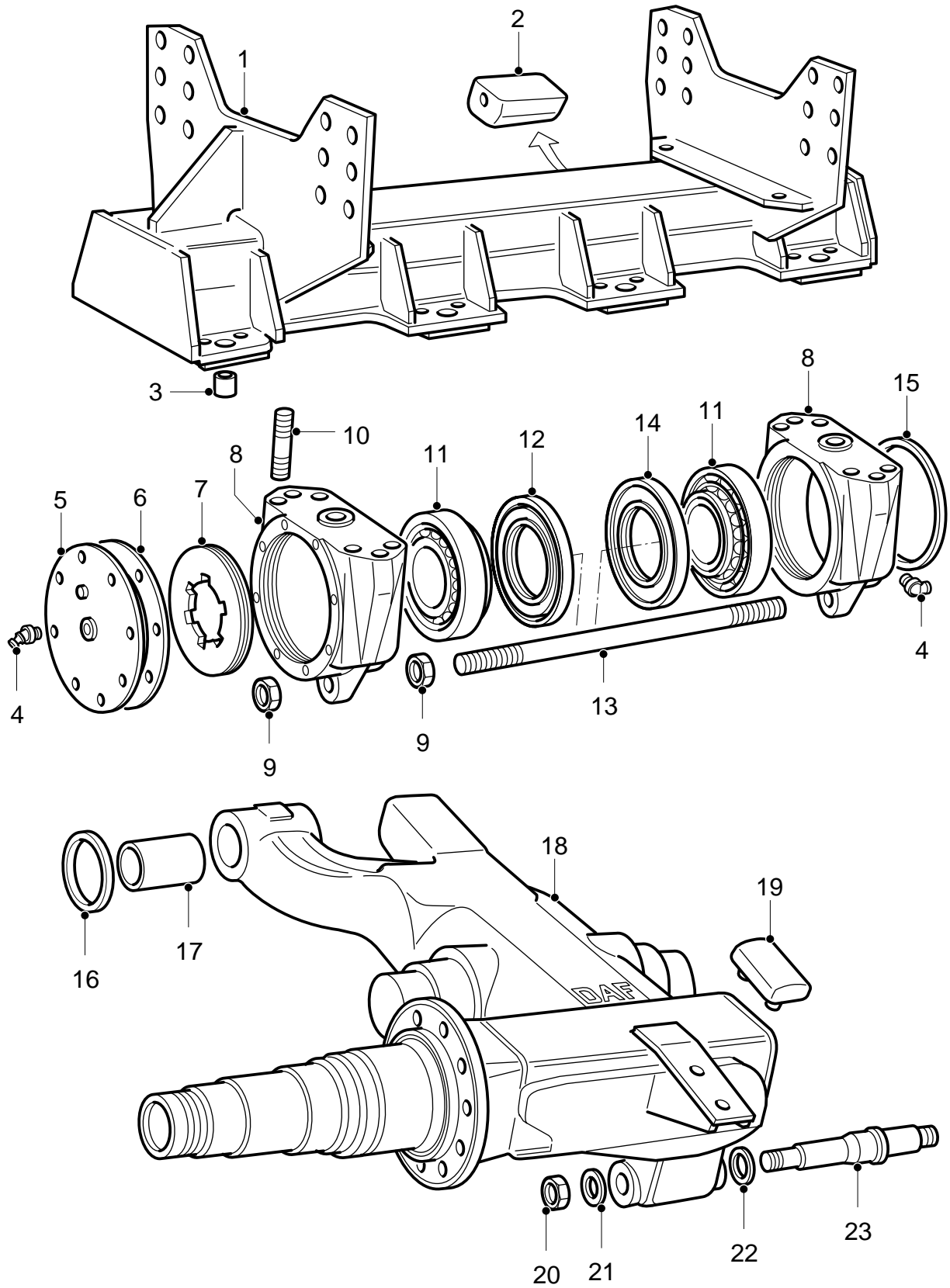

8

A8 00 402

1. Bearing support
2. Stop block
3. Bush
4. Lubricating nipple
5. Trailing-axle yoke cover
6. Flange seal
7. Adjusting nut
8. Bearing block
9. Nut
10. Stud bolt
11. Taper roller bearing
12. Oil seal
13. Pull-rod/push-rod
14. Oil seal
15. Sealing plate
16. Bearing-bush rings
17. Bearing bush
18. Trailing-axle yoke
19. Stop block
20. Nut
21. Sealing ring
22. Sealing ring
23. Pin



## 2. REMOVAL AND INSTALLATION

### 2.1 REMOVAL AND INSTALLATION, WHEEL HUB UNIT (09N075 TRAILING AXLE)

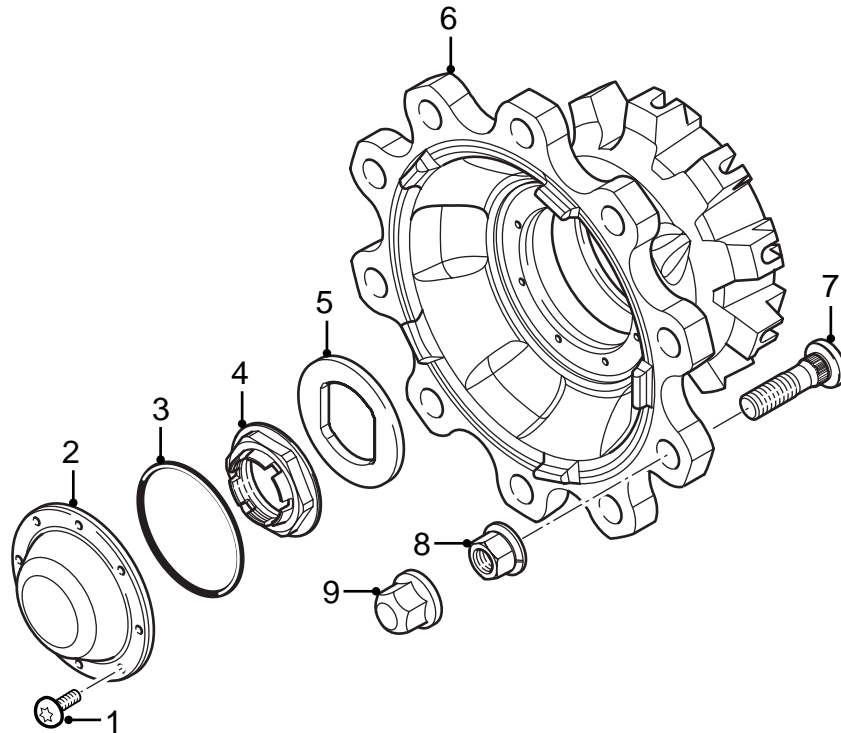

A8 00 404

#### Removing the wheel hub unit (09N075 trailing axle)

1. Lift the trailing axle and support it properly.
2. Remove the wheel.
3. Remove the brake calliper.
4. Remove the hub cap (2).

5. Remove the hub nut (4) using the special tool set (DAF no. 1329496). Fit the socket wrench (A) to the hub nut. Fit the socket wrench guide (B) to the wheel hub unit using four wheel studs. Loosen the nut using a torque amplifier.
6. Remove the thrust washer (5).

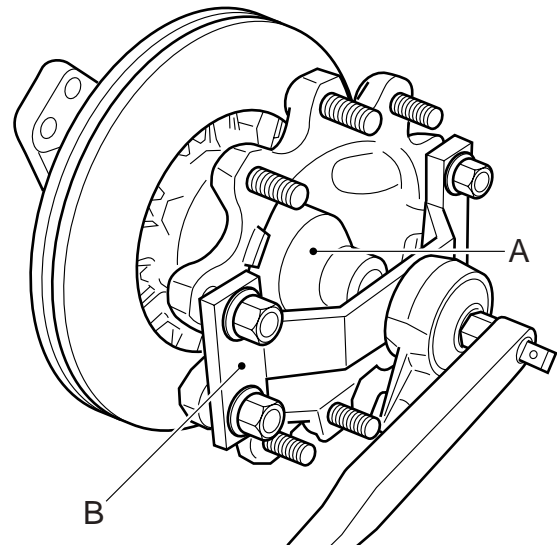

S7 00 641

7. Install the guide sleeve (A), which is part of the special tool set (DAF no. 1329496), on the axle journal.
8. Remove the wheel hub unit (6) using a lifting device. Take care that the wheel hub unit does not rest on the guide bush (A) as the latter is not strong enough to take the weight of the wheel hub unit.

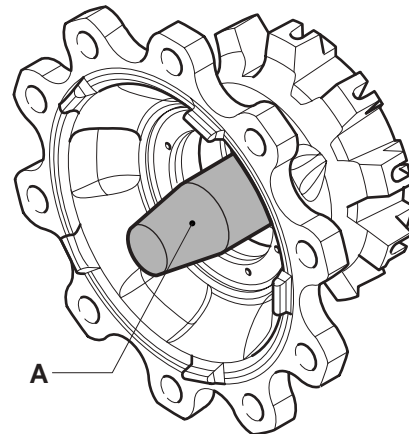

S7 00 580

### Installing the wheel hub unit

1. Check the axle journal thread carefully for damage.



**You must never fit a wheel hub unit on an axle journal with a damaged thread.**

2. Apply a thin and even layer of the prescribed lubricant to the entire circumference of the axle journal, see "Technical data".

#### Note:

Do not overlubricate the axle journal. While fitting the wheel hub unit, the excess grease will collect at the backside of the wheel hub. When the vehicle is used in daily operation, this can leak out so that the seal wrongly appears to be leaking.

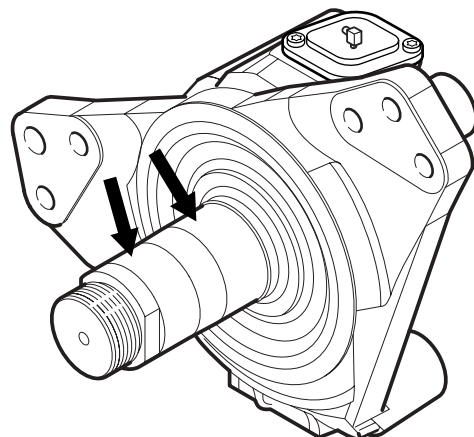

S7 00 547

3. Install the guide sleeve (A), which is part of the special tool set (DAF no. 1329496), on the axle journal.

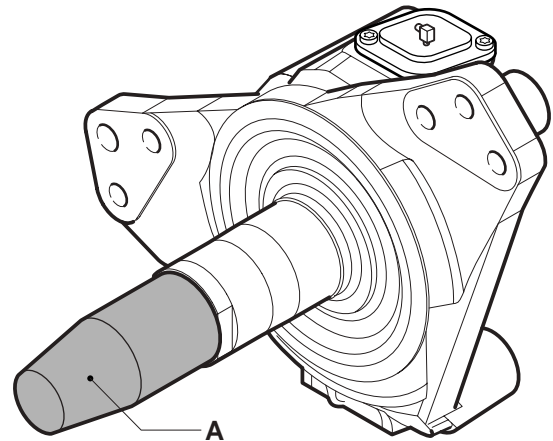

S7 00 561

4. Position the wheel hub unit (6) precisely in front of the axle journal using a lifting device. Slide the wheel hub unit (6) onto the axle journal without twisting it. Take care that the wheel hub unit does not rest on the guide bush (A) as the latter is not strong enough to take the weight of the wheel hub unit.
5. Fit the thrust washer (5).
6. Replace the hub nut (4). Apply a few drops of oil to the abutting surface of the hub nut. Fit the hub nut.

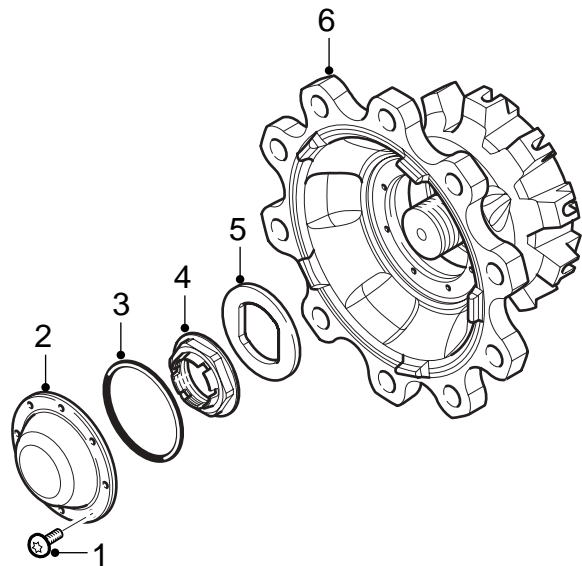

S7 00 581

7. Fit the hub nut (4) using the special tool set (DAF no. 1329496). Fit the socket wrench (A) to the hub nut. Fit the socket wrench guide (B) to the wheel hub unit using four nuts. Tighten the hub nut (4) in the specified manner using a torque amplifier, see "Technical data".
8. Fit a new O-ring (3) to the hub cap (2).
9. Fit the brake calliper.
10. Fit the wheel.

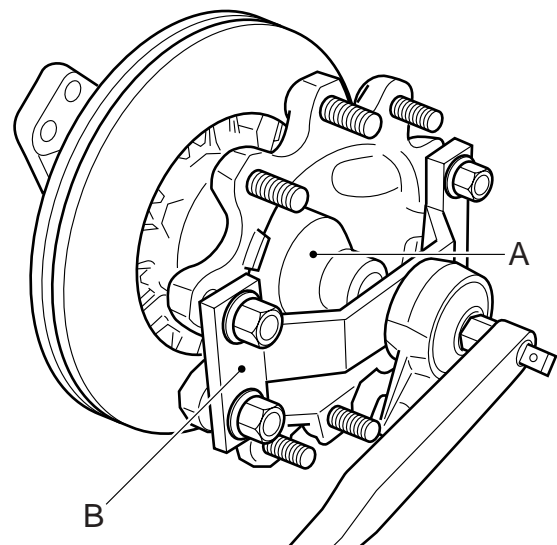

S7 00 641

## 2.2 REMOVAL AND INSTALLATION, WHEEL HUB (09N220 TRAILING AXLE)

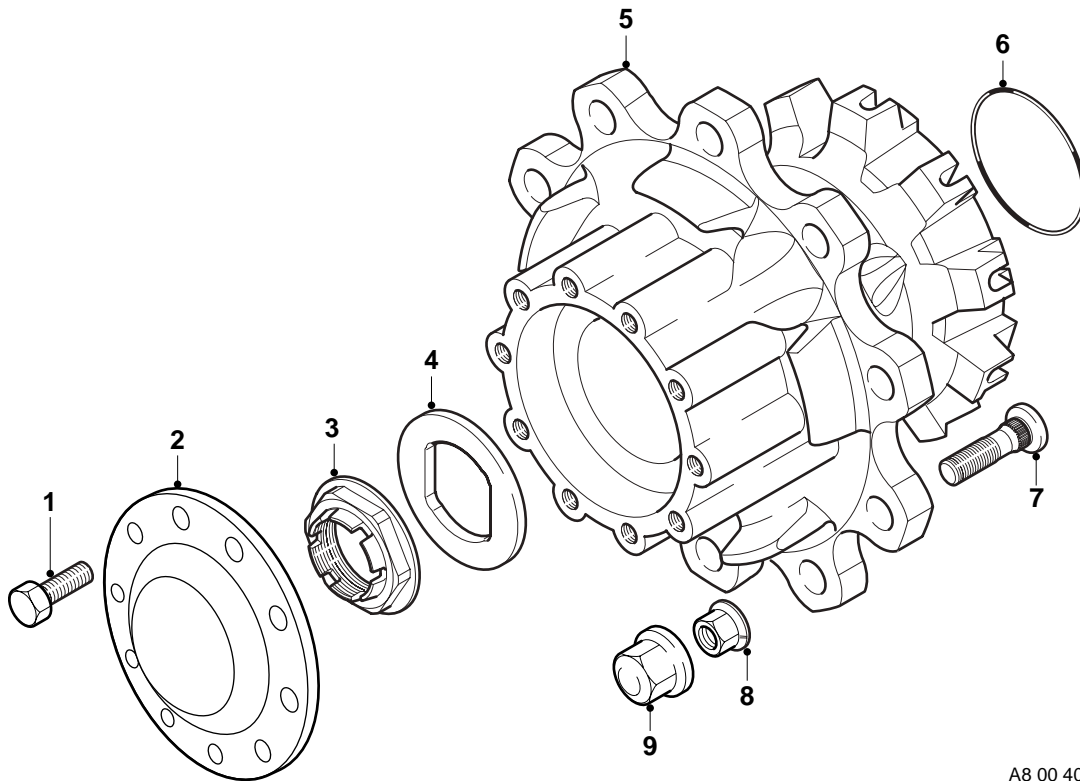

A8 00 403

8

### Removing the wheel hub (09N220 trailing axle)

1. Remove the attachment bolts (1) from the hub cap (2) and remove the cap.
2. Lift the trailing axle and support it properly.
3. Remove the wheel.
4. Remove the brake calliper.
5. Remove the hub nut (3) using the hub nut wrench (A), which is part of the special tool set (DAF no. 1329496). Loosen the hub nut (3), using a torque amplifier to do so.
6. Remove the thrust washer (4).

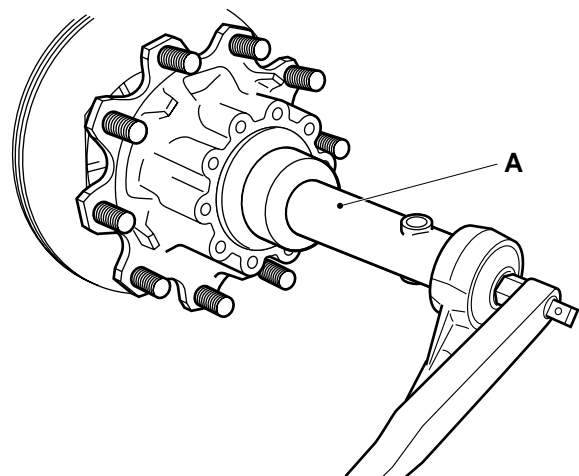

A8 00 405



7. Install the guide sleeve (A), which is part of the special tool set (DAF no. 1329496), on the axle journal.
8. Attach the wheel hub unit (5) securely to a movable lifting device.
9. Slide the wheel hub unit (5) from the axle journal using the lifting device.  
Take care that the wheel hub unit (5) does not rest on the guide bush (A) as the latter is not strong enough to take the weight of the wheel hub unit (5).
10. Remove the O-ring (6) from the wheel hub unit (5).

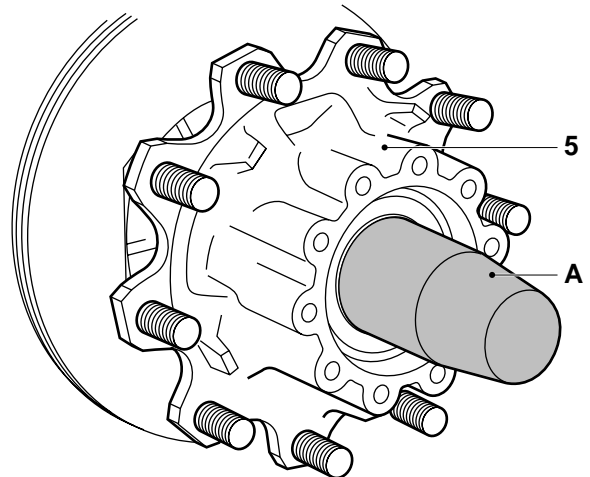

A8 00 411

### Installing the wheel hub

1. Check the axle journal thread carefully for damage.



**You must never fit a wheel hub on an axle journal with a damaged thread.**

2. Fit the O-ring (6) into the wheel hub unit (5).

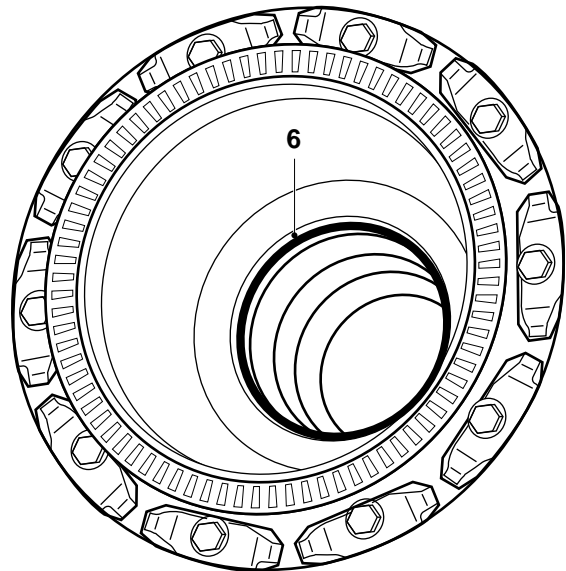

A8 00 412

3. Apply a thin and even layer of the prescribed lubricant to the axle journal, see "Technical data".

#### Note:

Do not overlubricate the axle journal. While fitting the wheel hub unit, the excess grease will collect at the backside of the wheel hub. When the vehicle is used in daily operation, this anti-corrosion agent can leak out so that it looks as if the oil seal leaks.

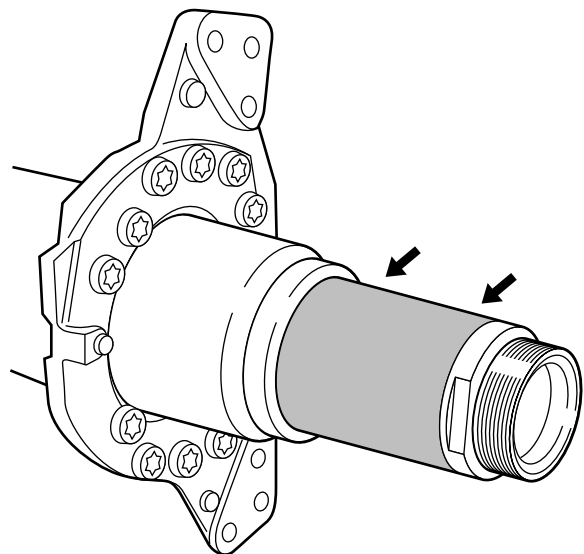

A8 00 344

4. Install the guide sleeve (A), which is part of the special tool set (DAF no. 1329496), on the axle journal.
5. Attach the wheel hub unit (5) securely to a movable lifting device.
6. Position the wheel hub unit (5) exactly in front of the axle journal using the movable lifting device. Slide the wheel hub unit (5) on the axle journal.  
Take care that the wheel hub unit (5) does not rest on the guide bush as the latter is not strong enough to take the weight of the wheel hub unit (5).

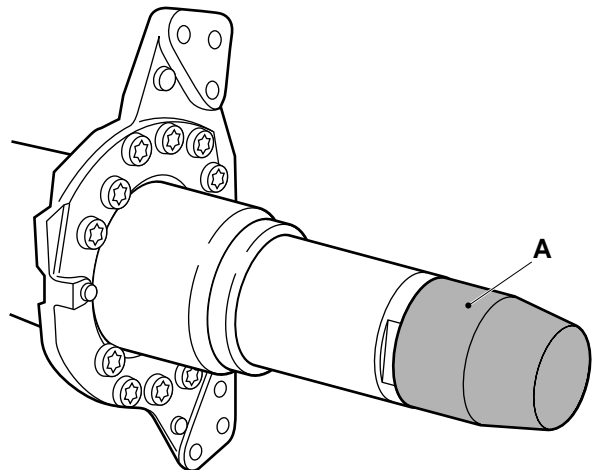

A8 00 343

7. Fit the thrust washer (4).
8. Replace the hub nut (3). Apply a few drops of oil to the abutting surface of the hub nut (3). Fit the hub nut (3).

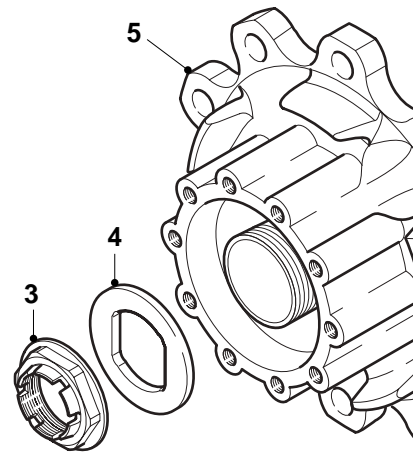

A8 00 413

9. Fit the hub nut (3) using the hub nut wrench (A), which is part of the special tool set (DAF no. 1329496) and a torque amplifier. Tighten the hub nut (3) in the specified manner using a torque amplifier, see "Technical data".
10. Thoroughly clean the sealing surfaces of the wheel hub and the hub cap.
11. Apply a sealant to one of the sealing surfaces.
12. Fit the hub cap.
13. Fit the brake calliper.
14. Put the wheels back on.

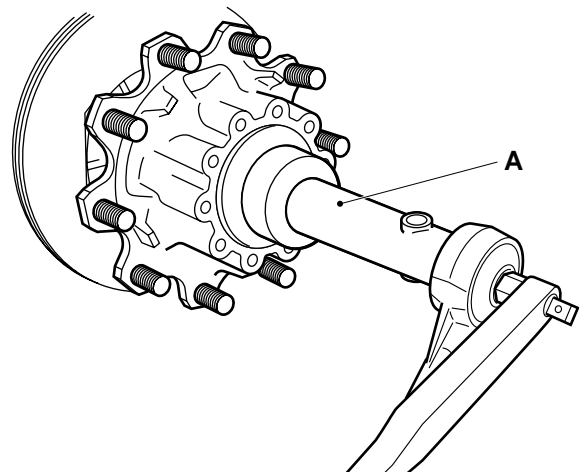

A8 00 405

## 2.3 REMOVAL AND INSTALLATION, TRAILING AXLE

### Removing the trailing axle

1. Remove the wheels from the trailing axle.
2. Loosen the shock absorbers at the top and depress these as far as possible.
3. Remove the brake pipes and the cabling of the disc brakes.
4. (Temporarily) fit the outer wheels of the trailing axle.
5. Lower the trailing axle.
6. Safely lift the chassis rear until the attachment bolts holding the bearing supports to the chassis can be removed.
7. Remove the attachment bolts holding the bearing supports to the chassis.

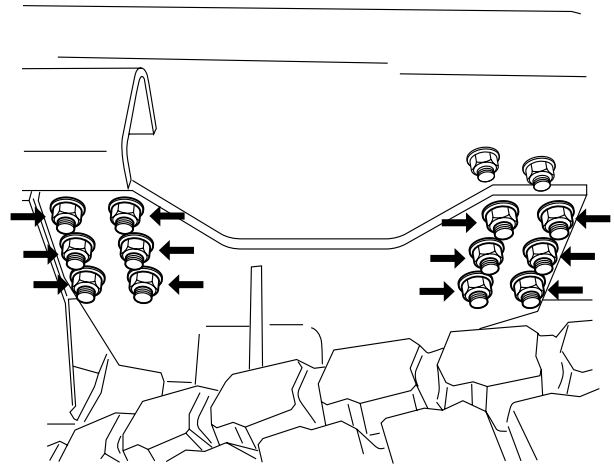

A8 00 408

8. Lift the chassis until the bearing supports are clear of the chassis and the bottom pins of the shackles are within reach.
9. Place a wooden block right and left between the chassis member and the axle housing of the driven axle.
10. Place suitable supports under the yokes where the shackle is attached.
11. Remove the lower pins from the shackles.

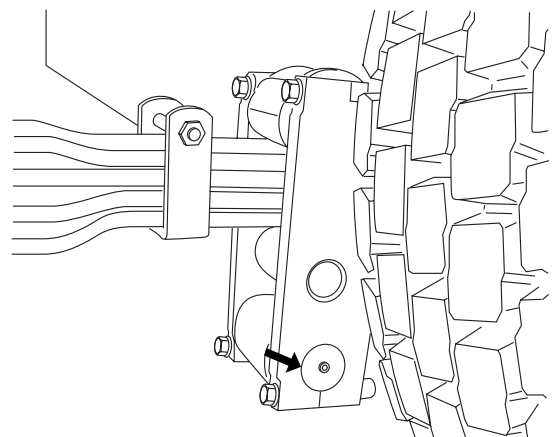

A8 00 409

12. Insert a solid piece of pipe through the eye of every yoke.
13. Position a trolley jack in the middle of the pipe, supporting it.
14. Remove the supports and slowly lower the pipe and the yokes.
15. Roll the trailing axle from under the chassis.
16. Slowly lower the chassis onto the wooden blocks.
17. Take the rings out of the eyes of the yokes if necessary.

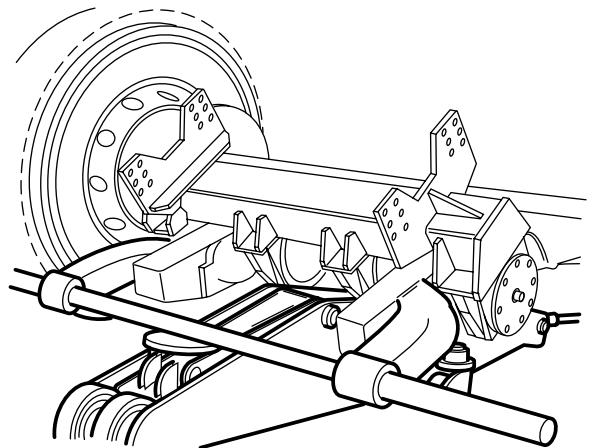

A8 00 406

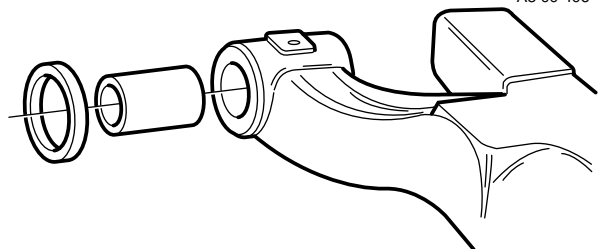

A800208

### Installing the trailing axle

1. Fit the rings in the eyes of the yokes.
2. Raise the chassis. Support the chassis in a safe way.
3. Insert a solid piece of pipe through the eye of every yoke.
4. Move the trailing axle under the chassis using a trolley jack. Align the trailing axle and the chassis.

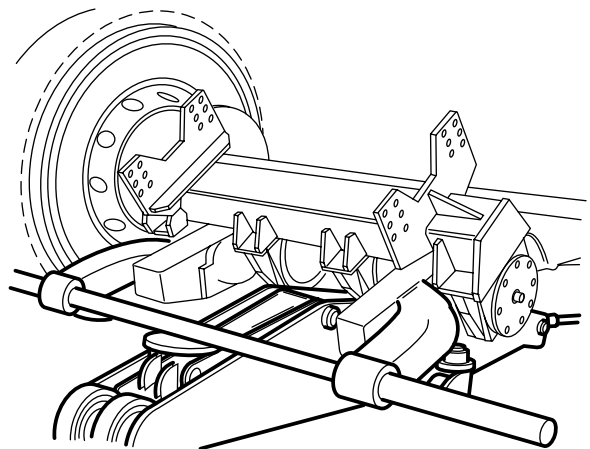

A8 00 406

5. Attach the shackles to the yokes.
6. Lower the chassis.

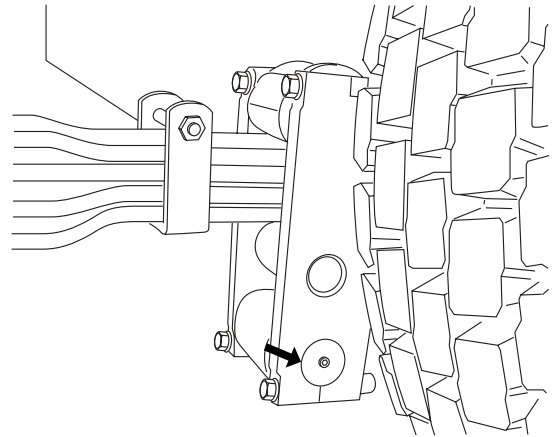

A8 00 409

7. Fit the attachment bolts with the bolt heads on the inside of the chassis. Tighten the bolts.
8. Fit the brake pipes and cabling.
9. Tighten the shock absorbers at the top.
10. Put the wheels back on.
11. Check the brake pipe connections for leaks.
12. Lubricate the shackle pins.

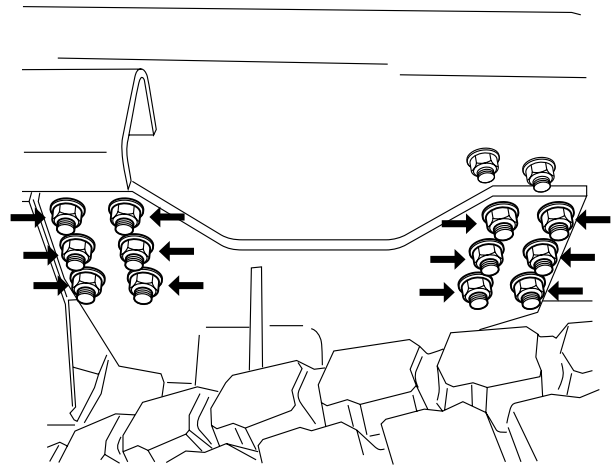

A8 00 408

## 2.4 REMOVAL AND INSTALLATION, TRAILING-AXLE YOKE

### Removing the trailing-axle yoke

1. Remove the trailing axle.
2. Support the trailing-axle yokes at the front and back in a safe way, so that they are horizontal.

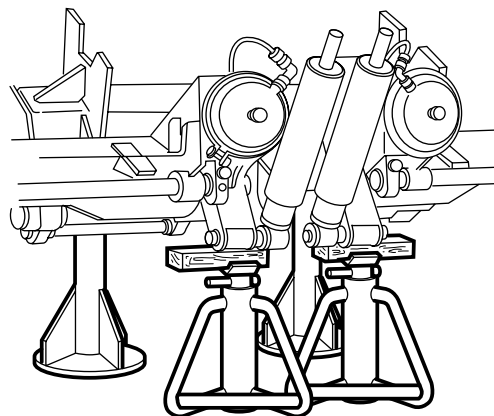

A8 00 424

3. Remove the outer cover. Remove the grease.

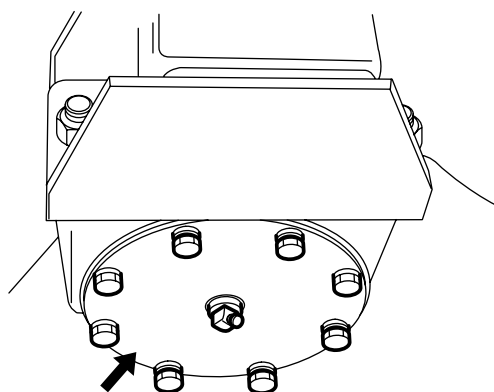

A8 00 416

4. Slacken the adjusting nut a couple of turns using the special tool (DAF no. 1453122).

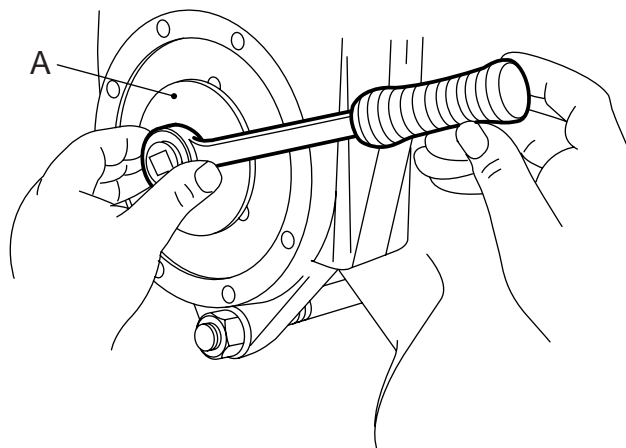

A8 00 414

- Loosen the nuts (1, 2, 4 and 5) of the push/pull rod (3).

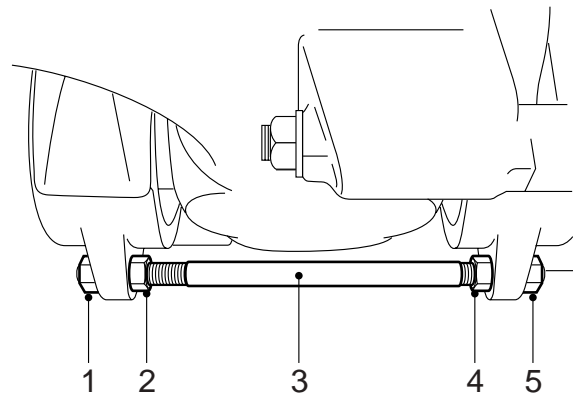

A8 00 407

- Mark the bearing blocks in relation to the bearing support.

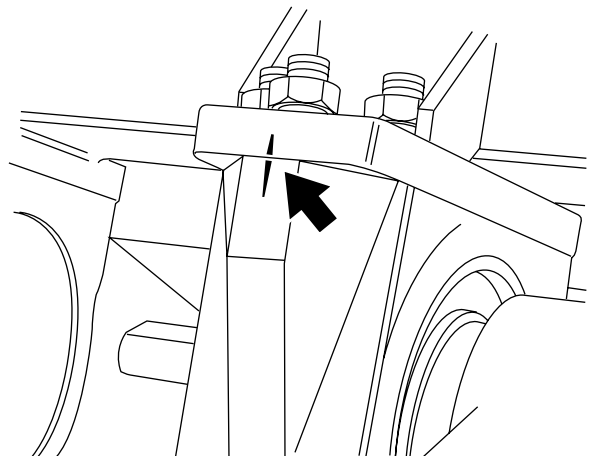

A800210

- Remove the attachment nuts from the bearing block. Remove the bearing support from the bearing blocks.



A8 00 410

8. Remove the adjusting nut from the bearing block.

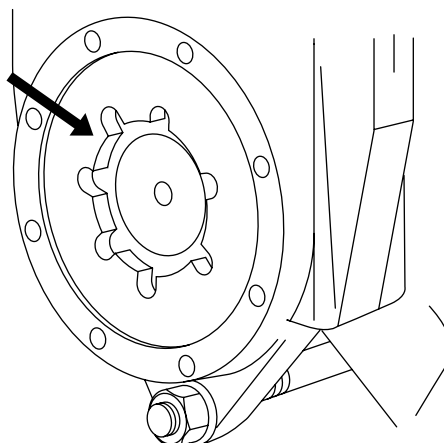

A8 00 420

9. Remove the outer nut (1) of the push/pull rod (3).

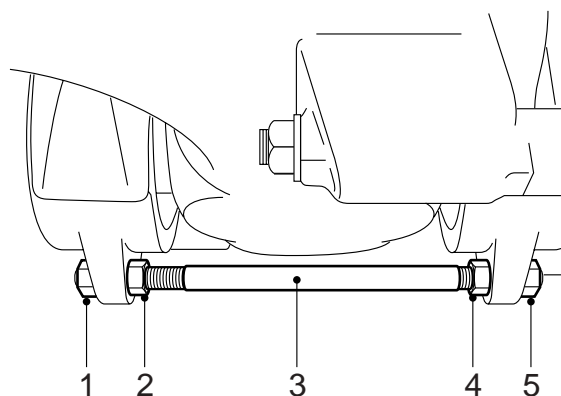

A8 00 407

10. Use two band irons to remove the outer bearing block from the axle journal. The bearing cage of the roller bearing will remain on the axle journal and at the same time retain the oil seal.

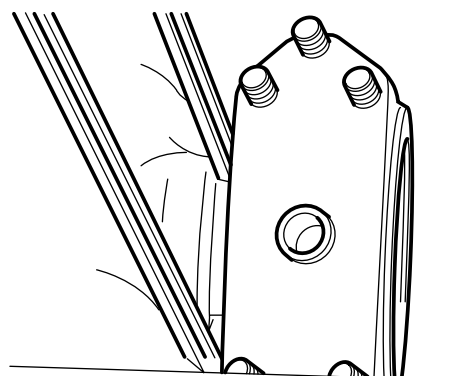

A800214



11. Remove the bearing cage from the axle journal. Remove the oil seal from the axle journal.

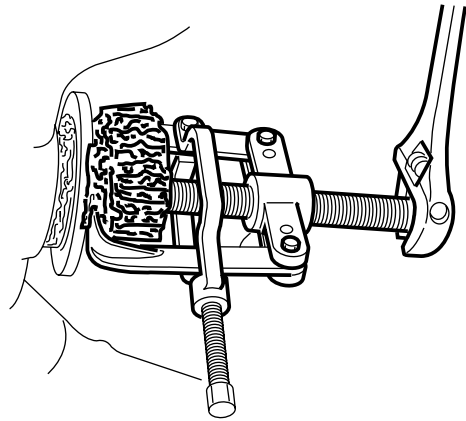

A8 00 417

12. Similarly remove the inner bearing block with bearing and oil seal from the axle journal.
13. Tap the sealing plate off the inner bearing from inside the bearing block, if the outer race of the roller bearing must be removed.

#### Installing the trailing-axle yoke

1. Clean the axle journals and bearing blocks.
2. Clean and check all bearings for wear and damage.
3. Apply new grease to the bearings.
4. Fit the bearing in the inner bearing block.

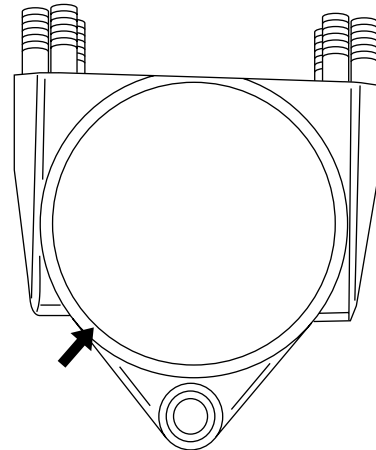

A8 00 418

5. Fit the seals at the indicated positions in the bearing blocks.

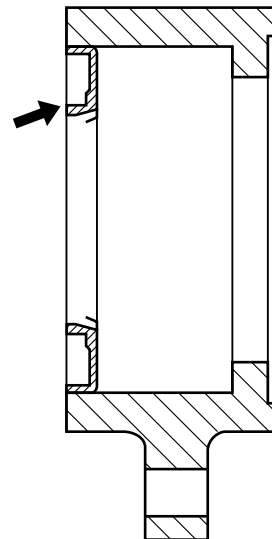

A8 00 423

6. Lightly grease the axle journals.

7. Fit the inner bearing block to the axle journal.

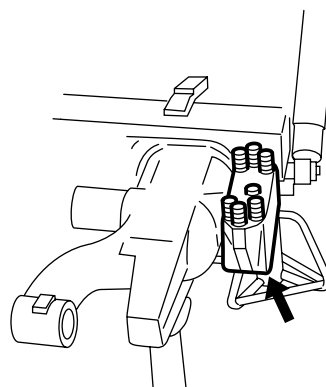

A8 00 422

8. Fit the sealing plate and lock it by tapping the centring edge inward in eight places.

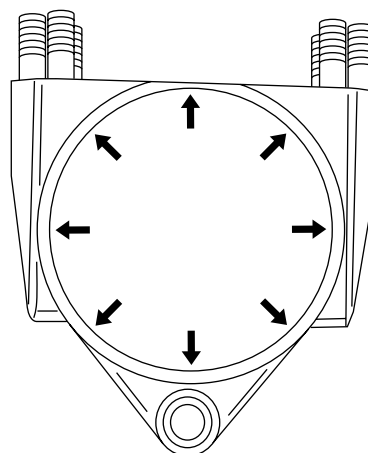

A8 00 419

9. Fit the outer bearing block to the axle journal. Make sure that the push/pull rod is inserted through the eye of the bearing block.

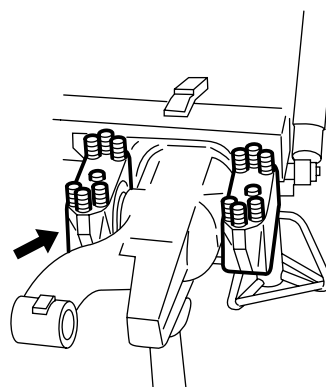

A8 00 421

10. Fit the bearing in the outer bearing block.
11. Screw the adjusting nut several turns into the bearing block.

12. Turn the outer nut (1) of the push/pull rod onto the push/pull rod.

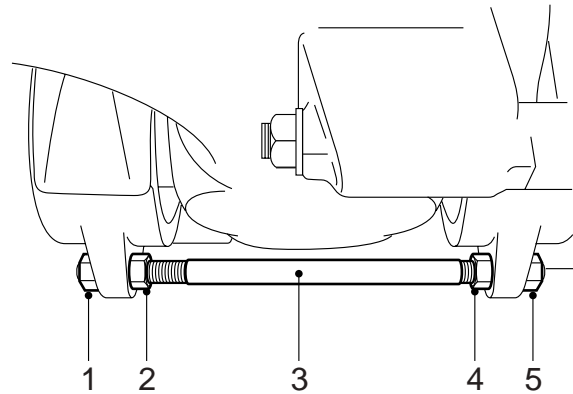

A8 00 407

13. Clean the contact surfaces of the bearing blocks and bearing support. Check that all adjusting bushes are present.
14. Fit the bearing blocks into their original positions on the bearing support. Evenly tighten the attachment nuts to the specified torque.

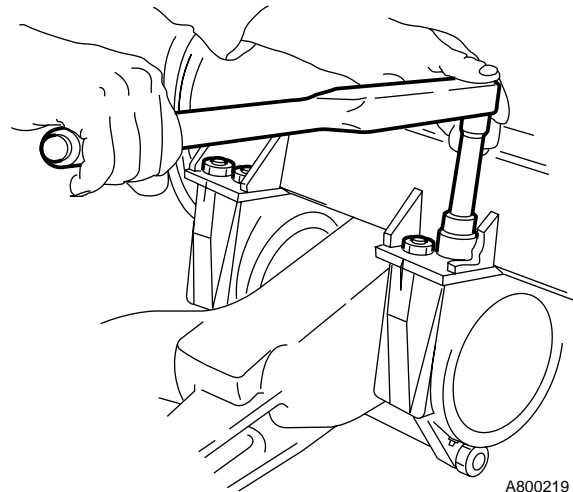

A800219

15. Turn the inner nuts (2) and (4) of the push/pull rod (3) against the bearing block.
16. Tighten the outer nuts (1) and (5) of the push/pull rod (3) to the specified torque, see "Technical data".

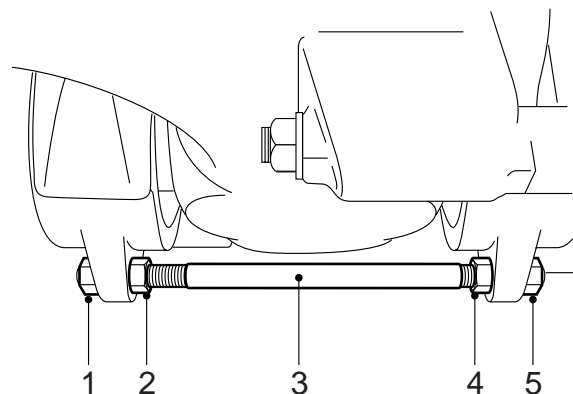

A8 00 407

17. Tighten the adjusting nut to the specified torque using the special tool (A) (DAF no. 1453122), see "Technical data".
18. Loosen the adjusting nut. Re-tighten the adjusting nut to the specified torque. See "Technical data".

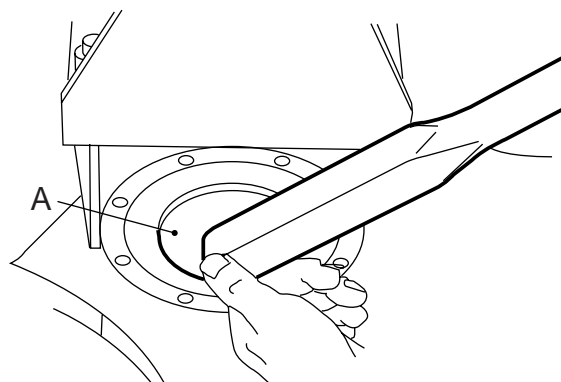

A8 00 415

19. Fit a new gasket to the cover and fit the cover. The lock cam on the inside of the cover must fall into a recess in the adjusting nut. If it does not, turn the adjusting nut to the smallest angle (loosen or tighten) until the lock cam falls into a recess.
20. Fit the cover attachment bolts.
21. Lubricate the bearing blocks until a collar of grease is visible at the seals.

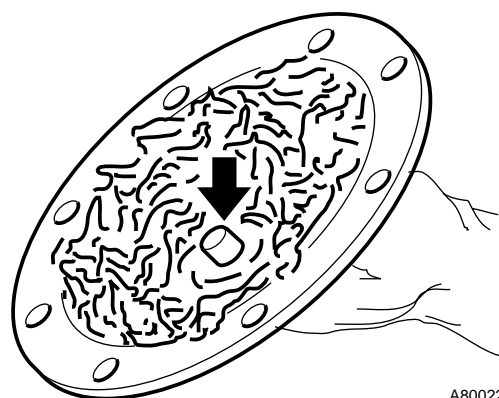

A800221

## CONTENTS

	Page	Date
<b>1. SAFETY INSTRUCTIONS</b> .....	1-1 .....	200424
1.1 Safety instructions .....	1-1 .....	200424
<b>2. GENERAL</b> .....	2-1 .....	200424
2.1 Location of components .....	2-1 .....	200424
2.2 System description, hydraulic part .....	2-2 .....	200424
2.3 Overview drawing, pump unit .....	2-4 .....	200424
2.4 Overview drawing, 2/2 solenoid valve .....	2-6 .....	200424
2.5 Overview drawing, 4/2 solenoid valve .....	2-7 .....	200424
2.6 Overview drawing, pressure relief valve .....	2-8 .....	200424
2.7 Overview drawing, cylinder .....	2-9 .....	200424
<b>3. INSPECTION AND ADJUSTMENT</b> .....	3-1 .....	200424
3.1 Checking the system pressure and pressure switch .....	3-1 .....	200424
3.2 Inspection and adjustment, pressure relief valve .....	3-2 .....	200424
3.3 Checking internal leakage in the pump unit .....	3-4 .....	200424
3.4 Bleeding of the hydraulic lifting gear .....	3-5 .....	200424
3.5 Checking the fluid level in the hydraulic lifting gear .....	3-5 .....	200424
3.6 Checking the cylinder .....	3-6 .....	200424
<b>4. REMOVAL AND INSTALLATION</b> .....	4-1 .....	200424
4.1 Removal and installation, pump unit .....	4-1 .....	200424
4.2 Removal and installation, 4/2 solenoid valve .....	4-3 .....	200424
4.3 Checking the fluid level in the hydraulic lifting gear .....	4-4 .....	200424
4.4 Removal and installation, pressure relief valve .....	4-5 .....	200424
4.5 Removal and installation, cylinder .....	4-6 .....	200424
<b>5. DISASSEMBLY AND ASSEMBLY</b> .....	5-1 .....	200424
5.1 Disassembly and assembly, pump unit .....	5-1 .....	200424
5.2 Disassembly and assembly, 2/2 solenoid valve .....	5-4 .....	200424
5.3 Disassembly and assembly, cylinder .....	5-6 .....	200424
<b>6. DRAINING AND FILLING</b> .....	6-1 .....	200424
6.1 Filling the hydraulic lifting gear .....	6-1 .....	200424



## 1. SAFETY INSTRUCTIONS

### 1.1 SAFETY INSTRUCTIONS

- Repair and maintenance activities must only be carried out while the trailing axle is lowered.  
When the trailing axle is lifted, the line connected to line connection B (imprinted on the pump unit) is pressurised.
- Stay at a safe distance from the moving parts when activating the lifting gear.
- Avoid skin contact with hydraulic oil.
- Use T-pieces and couplings which are suited for high system pressures when connecting a pressure gauge.
- Before the pump unit is tested for internal leakage, always begin by checking the function of the pressure relief valve.
- Never stand in front of the piston rod when testing the cylinder.
- The surface of the cylinder piston rods can be easily damaged. Even the smallest damage to the surface will result in leakage.

During repair or maintenance activities which could cause damage to the piston-rod surfaces, the trailing axle should be lowered. In that case the piston rods will be retracted into the cylinders.

During activities such as welding, grinding, paint spraying and applying bitumen coatings, it is especially important to cover any cylinder-rod parts still protruding from the cylinder.

Also cover the pipes.





## 2. GENERAL

### 2.1 LOCATION OF COMPONENTS

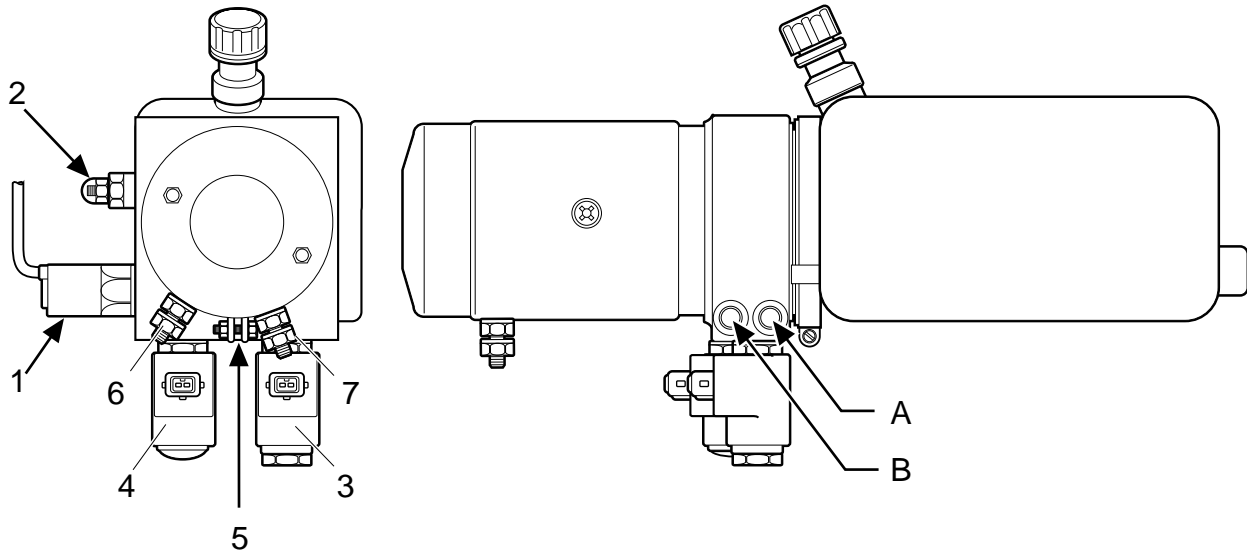

A8 00 247

1. Pressure switch
  2. Pressure relief valve
  3. 4/2 solenoid valve (lift trailing axle)
  4. 2/2 solenoid valve (lower trailing axle)
  5. Built-in non-return valve
  6. + connection point (D1E1)
  7. - connection point (D2E2)
- 
- A. Line connection (delivery line while lowering)
  - B. Line connection (delivery line while lifting)  
(The characters are imprinted on the pump unit)

#### Relays, diodes and fuse

The relay, diodes and fuse that have a bearing on the lifting gear of the trailing axle are stored in a watertight box.

This box is fitted on the inside of the chassis on the chassis main member.

## 2.2 SYSTEM DESCRIPTION, HYDRAULIC PART

The hydraulic part of the trailing axle load transfer device is composed of a pump unit and two parallel, double-acting cylinders. Both when lifting and lowering the trailing axle, the pump will deliver oil to the cylinders.

The pump unit is composed of a gear pump which is driven by an electric motor, a plastic reservoir and a valve block.

The valve block is equipped with the following valves: a non-return valve (6), the pressure relief valve (2), the 4/2 valve "lift trailing axle" (3) and the 2/2 valve "lower trailing axle" (4).

The valve block is also equipped with a pressure switch (1).

When the lifting gear is not being operated, both solenoid valves (3) and (4) will be deactivated.

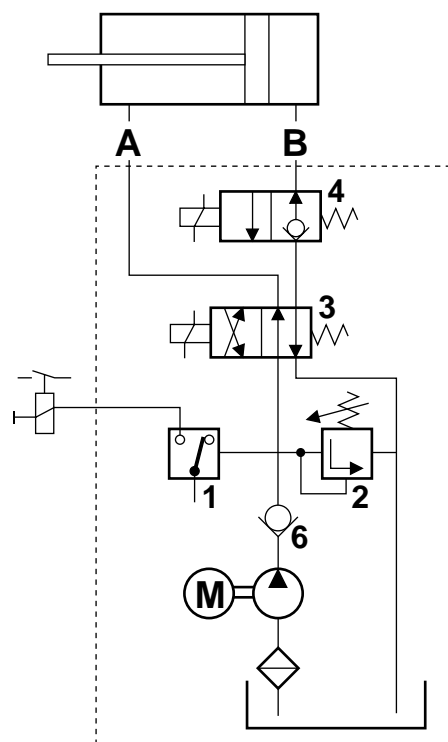

A8 00 257

### Lifting

- When the lifting-gear control switch is placed in the "lifting" position, the pump relay and the 4/2 solenoid valve (3) are activated. The activated solenoid valve (3) connects the pump delivery side to the space behind the pistons in the cylinders. The space in front of the pistons is connected to the reservoir.
- The pump relay activates the pump, after which oil is carried to the cylinders through line connection B. Due to the pressure build-up from the cylinders, the piston rods are pushed from the cylinders, thus lifting the trailing axle via the lever effect.
- When the trailing axle is fully lifted, the pressure in the system will build up until the switching value of the pressure switch (1) is reached. The pressure switch (1) will deactivate the pump motor. When the control switch is released, the 4/2 solenoid valve (3) is deactivated.
- The non-return valve built into the 2/2 solenoid valve (4) keeps the line pressurised and the trailing axle lifted.

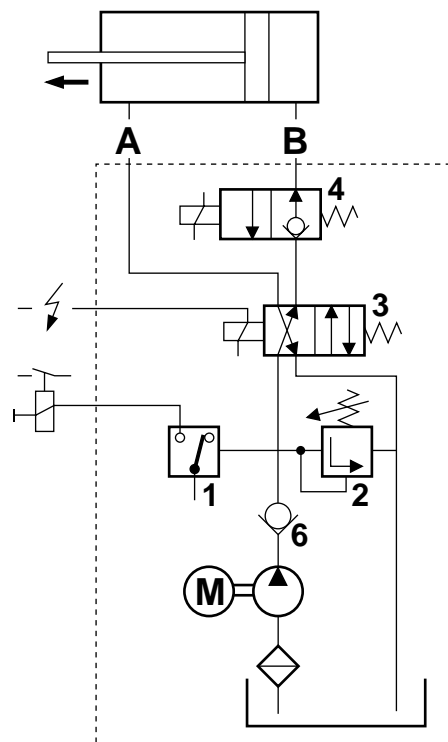

A8 00 258

**Lowering**

- When the lifting-gear control switch is placed in the "lowering" position, the pump relay and the 2/2 solenoid valve (4) are activated.
  - The activated solenoid valve will connect the space behind the pistons to the reservoir. In its neutral position the 4/2 solenoid valve (4) connects the pump delivery side to the space in front of the pistons in the cylinders.
  - The pump relay activates the pump after which oil is carried to the cylinders through line connection A. Due to the pressure build-up in the cylinders the piston rods are retracted, thus lowering the trailing axle.
  - When the pistons are fully retracted into the cylinders, the pressure in the system will build up until the switching value of the pressure switch is reached. The pressure switch will deactivate the pump motor. The 2/2 solenoid valve (4) remains activated for approx. 2.5 minutes.
  - The line connected to line connection B will be pressureless after deactivating the pump.
  - The line connected to line connection A will remain pressurised immediately after deactivating the pump.
- Due to minor internal leakage in the 4/2 solenoid valve (3) the pressure in the line will be slowly reduced after the pump is deactivated. After approx. 5 minutes the pressure in the line will have been reduced to approx. 5 bar.

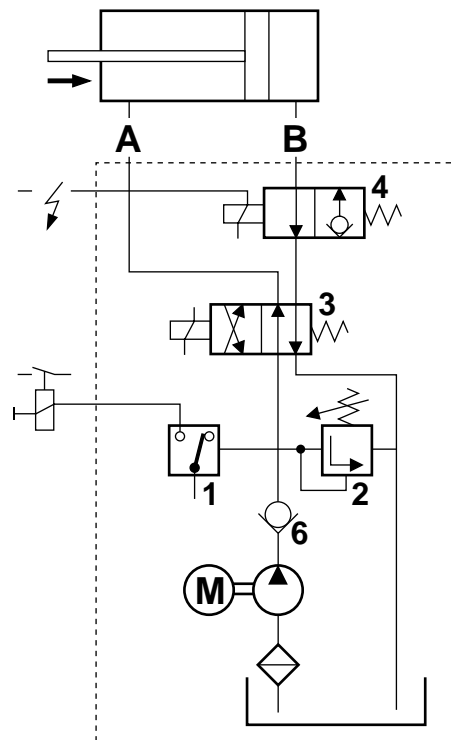

A8 00 259

2.3 OVERVIEW DRAWING, PUMP UNIT

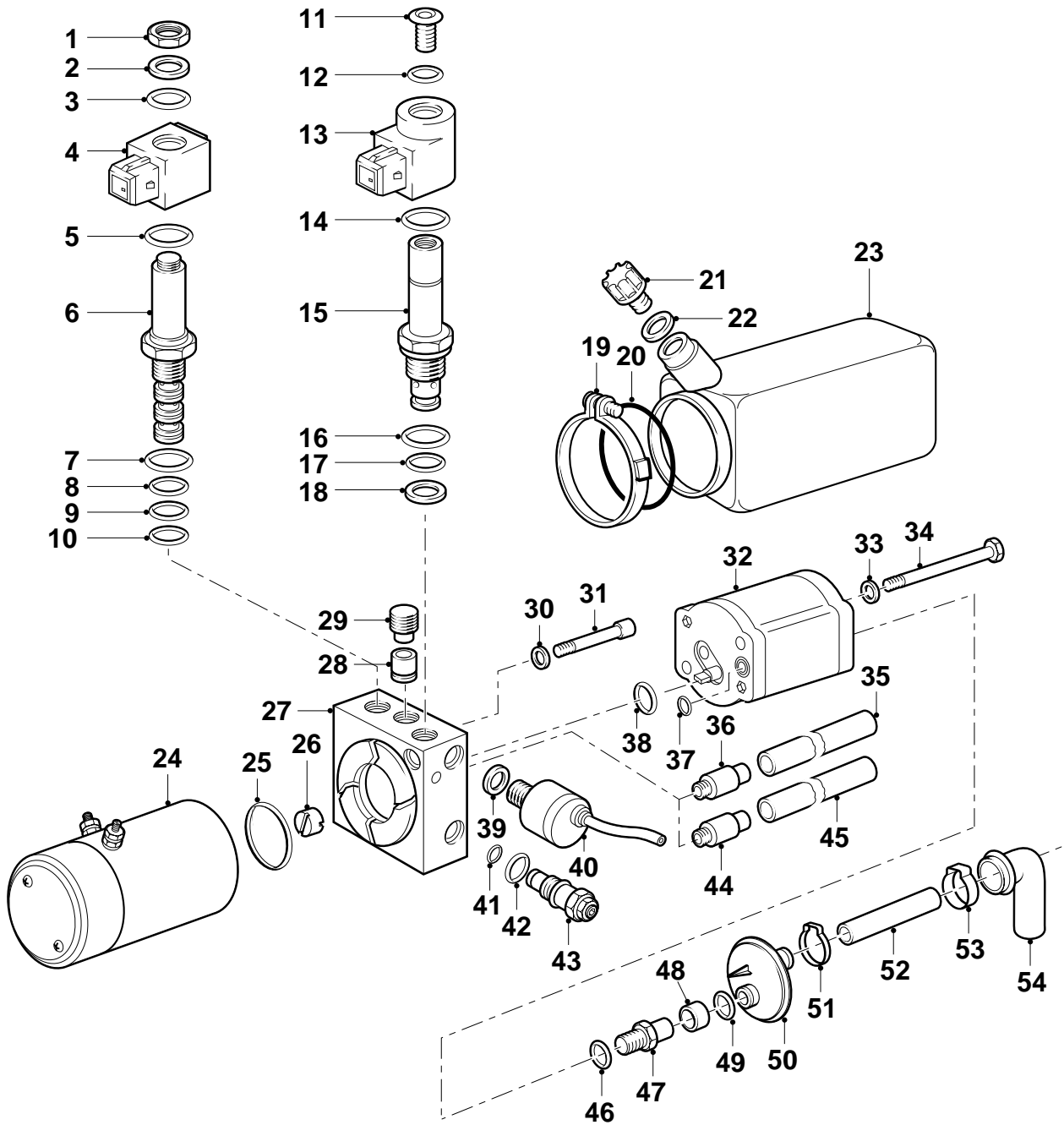

A8 00 277

1. Nut
2. Spacer ring
3. O-ring
4. Coil
5. O-ring
6. 4/2 valve
7. O-ring
8. O-ring
9. O-ring
10. O-ring
11. Allen screw
12. O-ring
13. Coil
14. O-ring
15. 2/2 valve
16. O-ring
17. O-ring
18. Plastic ring
19. Clamping strap
20. O-ring
21. Cap
22. Gasket ring
23. Reservoir
24. Engine
25. O-ring
26. Coupling disc
27. Valve block
28. Non-return valve
29. Plug
30. Sealing ring
31. Allen screw
32. Pump
33. Sealing ring
34. Bolt
35. Return pipe
36. Clutch
37. O-ring
38. O-ring
39. O-ring
40. Pressure switch
41. O-ring
42. O-ring
43. Pressure relief valve
44. Clutch
45. Return pipe
46. O-ring
47. Clutch
48. Hose clamp
49. O-ring
50. Filter
51. Hose clamp
52. Supply pipe
53. Hose clamp
54. Inlet pipe

## 2.4 OVERVIEW DRAWING, 2/2 SOLENOID VALVE

1. Allen screw
2. O-ring
3. Coil
4. O-ring
5. Valve casing (2/2 valve)
6. O-ring
7. O-ring
8. Plastic ring

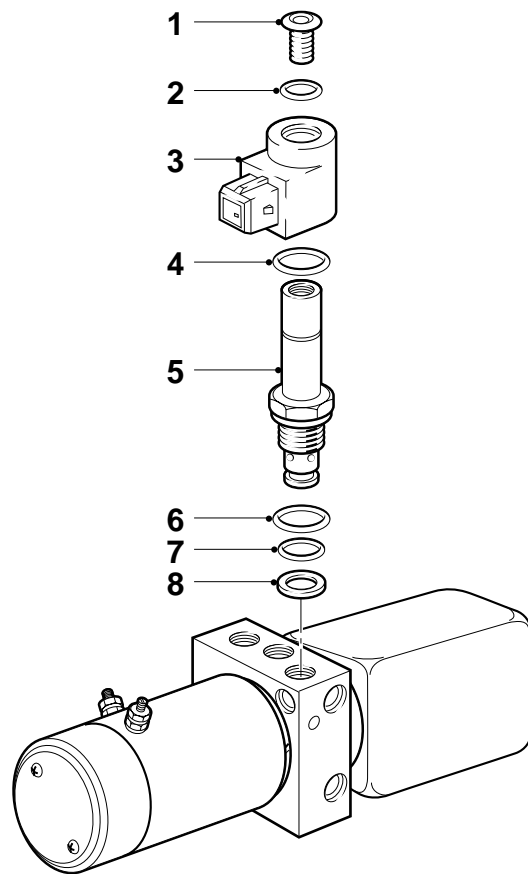

A8 00 251

9

1. Valve casing (2/2 valve)
2. O-ring
3. Adjusting ring(s)
4. Magnet core
5. Bush
6. Spring
7. Valve
8. Holder
9. O-ring
10. Plastic ring

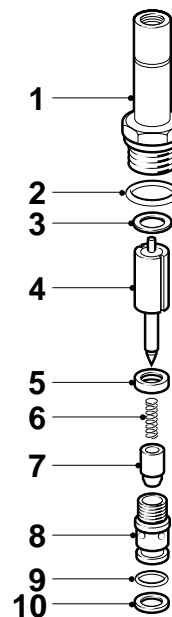

A8 00 254

## 2.5 OVERVIEW DRAWING, 4/2 SOLENOID VALVE

1. Nut
2. Spacer ring
3. O-ring
4. Coil
5. O-ring
6. 4/2 valve
7. O-ring
8. O-ring
9. O-ring
10. O-ring

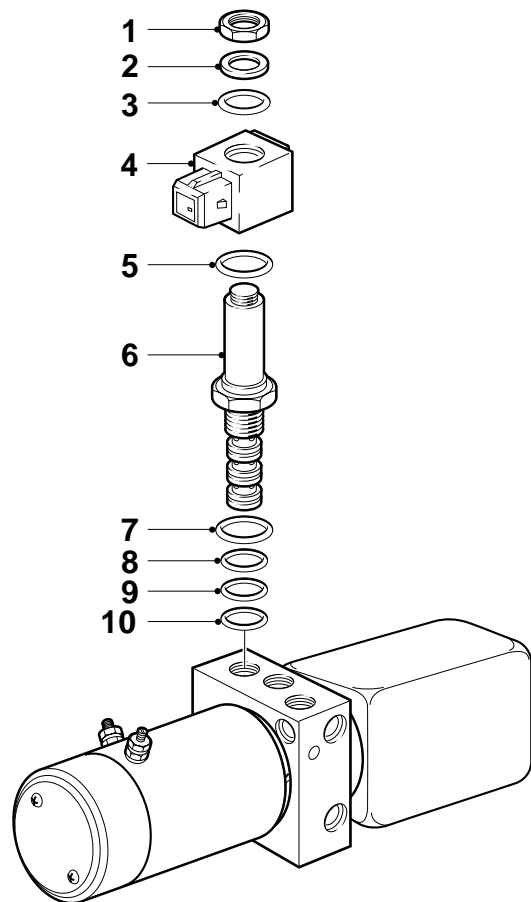

A8 00 252

## 2.6 OVERVIEW DRAWING, PRESSURE RELIEF VALVE

1. O-ring
2. O-ring
3. Pressure relief valve

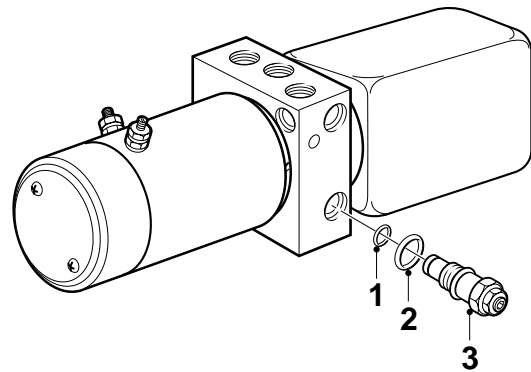

A8 00 276



## 2.7 OVERVIEW DRAWING, CYLINDER

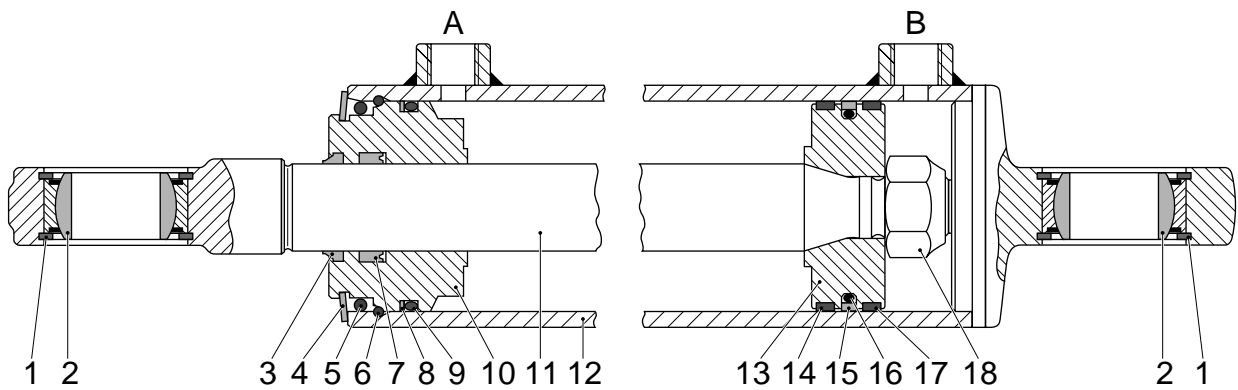

A8 00 248

1. Circlip
2. Bearing
3. Dirt scraper
4. Circlip
5. O-ring
6. Spring clip
7. Sealing ring
8. Plastic ring
9. O-ring
10. Piston-rod guide
11. Piston rod
12. Cylinder
13. Piston
14. Plastic ring
15. Sealing ring
16. O-ring
17. Plastic ring
18. Nut

- A Pipe connection  
B Pipe connection



### 3. INSPECTION AND ADJUSTMENT

#### 3.1 CHECKING THE SYSTEM PRESSURE AND PRESSURE SWITCH

1. Make sure that the trailing axle wheels are fully lowered and on the ground.
2. Connect the pressure gauge, special tool (DAF no. 0535653) to the pipe which is connected to pipe connection B by a T-piece (M16 x 1.5).
3. Lift the trailing axle and take the pressure reading. Compare the reading with the technical data. See "Technical data". The pressure switch cannot be adjusted. If the value deviates, the pressure switch should be replaced.
4. Lower the trailing axle and remove the T-piece and the pressure gauge.
5. Check the oil level in the reservoir and top up if necessary.

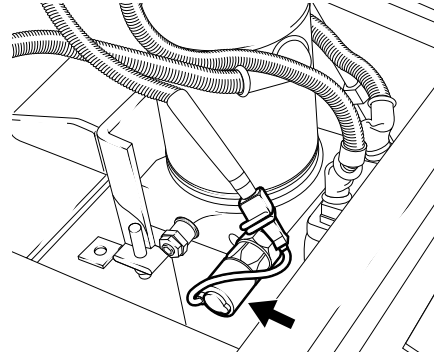

A8 00 278

### 3.2 INSPECTION AND ADJUSTMENT, PRESSURE RELIEF VALVE

#### Checking the pressure relief valve

1. Make sure that the trailing axle wheels are fully lowered and on the ground.
2. Connect the pressure gauge, special tool (DAF no. 0535653) to the pipe which is connected to pipe connection B by a T-piece (M16 x 1.5).
3. Detach the pressure switch connector.
4. Lift the trailing axle and take the pressure reading. Release the control switch on the dashboard immediately once the maximum pressure is achieved.

#### Note:

If the pressure exceeds 200 bar, the control switch on the dashboard should be released immediately.

5. Compare the reading with the technical data. See "Technical data". Adjust the pressure relief valve if the value deviates.
6. Fit the pressure switch connector.
7. Lower the trailing axle and remove the T-piece and the pressure gauge.
8. Check the oil level in the reservoir and top up if necessary.

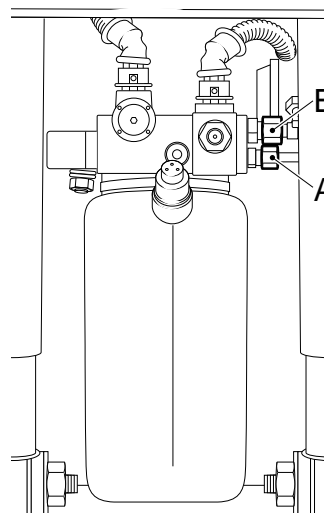

A8 00 281

#### Adjusting the pressure relief valve

1. Make sure that the trailing axle wheels are fully lowered and on the ground.
2. Connect the pressure gauge, special tool (DAF no. 0535653) to the pipe which is connected to pipe connection, B by a T-piece (M16 x 1.5).
3. Detach the pressure switch connector.
4. Loosen the lock nut (2) of the pressure relief valve (3).

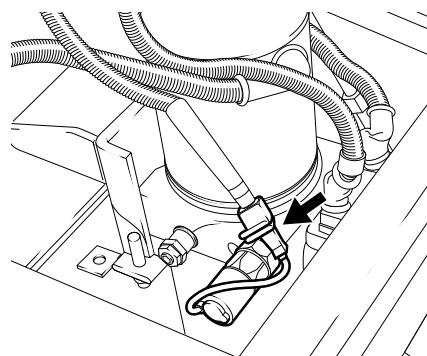

A8 00 280

5. Turn the adjusting bolt (1) using an Allen key. During the adjusting process the trailing axle should not be activated.
  - Screwing the bolt in will increase the pressure.
  - Unscrewing the bolt will decrease the pressure.
 Turn the adjusting bolt (1) using small steps of not more than 20°. Measure the pressure after each step.

**Note:**

As the pressure increases very rapidly, a large turn of the adjusting bolt can result in excessive system pressure causing damage.

6. Lift the trailing axle and take the pressure reading. Release the control switch on the dashboard immediately once the maximum pressure is achieved. If the pressure exceeds 200 bar, the control switch on the dashboard should be released immediately.
7. If the measured value is still incorrect: **connect the pressure-switch connector** and lower the trailing axle.
8. Turn the adjusting bolt (1) once again.
9. Remove the pressure switch connector.
10. Wait for approx. 2.5 minutes and take a new reading. If necessary, repeat points 7 to 10 until the pressure setting is correct.
11. Tighten lock nut (2). Make sure that the adjusting bolt (1) does not turn too.
12. Connect the connector of the pressure switch, lower the trailing axle and check the pressure again.
13. Remove the T-piece and pressure gauge.
14. Check the oil level in the reservoir and top up if necessary.

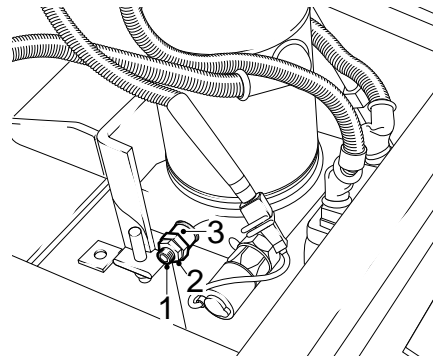

A8 00 279

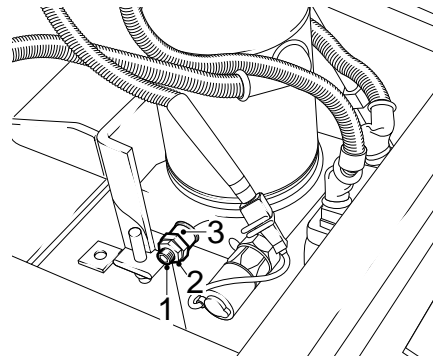

A8 00 279

### 3.3 CHECKING INTERNAL LEAKAGE IN THE PUMP UNIT

1. Check the setting of the pressure relief valve before conducting this test.
2. Lower the trailing axle. The wheels of the trailing axle must rest on the ground.
3. Clean pipe connection B of the pump unit.
4. Remove the pipe from pipe connection B and plug the pipe.
5. Connect the pressure gauge, special tool (DAF no. 0535653), to pipe connection B so that the pipe connection is also plugged.
6. Put the control switch into the "lifting" position. The pressure will quickly increase and the pressure switch will deactivate the pump motor. Release the control switch.
7. Take the pressure reading and check the outward leakage. Leave the pump unit in pressurised condition, also depending on the complaint (how quickly the trailing axle will be lowered by itself). If the pressure decreases, the non-return valve in the 2/2 solenoid valve or the gasket of the 2/2 solenoid valve is leaking.
8. Activate the 2/2 solenoid valve manually after the test using a 24V power supply. The 2/2 solenoid valve will be activated, rendering pipe connection B of the pump unit pressureless.
9. Remove the pressure gauge and reconnect the piping.
10. Activate the lifting gear and check the oil level in the reservoir. Inspect the pipe connections for leaks.

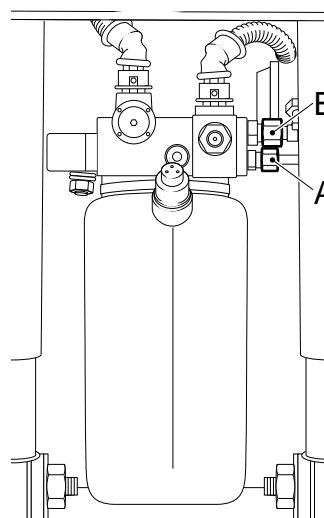

A8 00 281

### 3.4 BLEEDING OF THE HYDRAULIC LIFTING GEAR

The lifting gear is bled automatically. If necessary, lift and lower the trailing axle several times in a row.

The oil level in the reservoir should not fall below the minimum level.

Note: after lowering the trailing axle, wait approx. 2.5 minutes before lifting the trailing axle.

If the switch is activated before this time span of approx. 2.5 minutes elapses, the time will be reset and you will have to wait about another 2.5 minutes before you can lift the trailing axle.

### 3.5 CHECKING THE FLUID LEVEL IN THE HYDRAULIC LIFTING GEAR

1. Make sure that the trailing axle wheels are fully lowered and on the ground.
2. Check the fluid level. The liquid level must be between the "min." and "max." level mark. If necessary, top up.

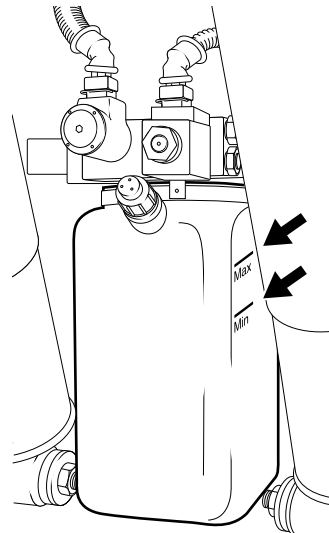

A8 00 282

### 3.6 CHECKING THE CYLINDER

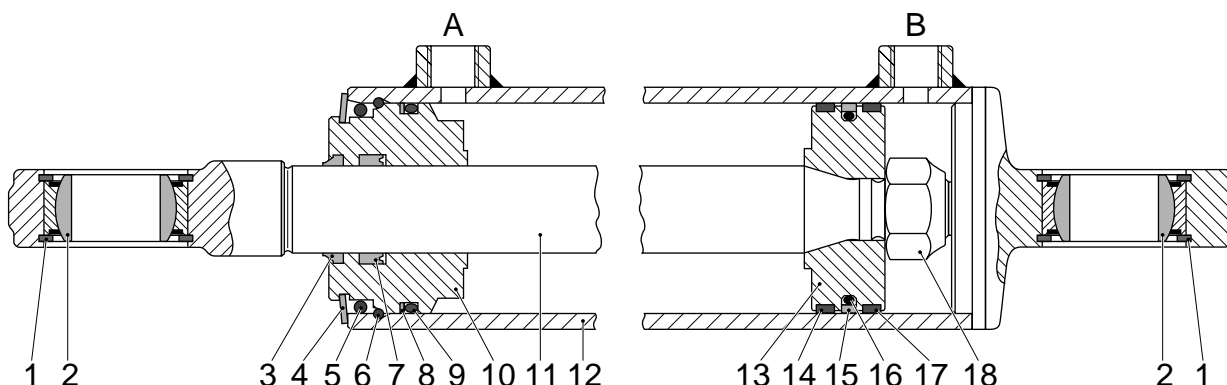

A8 00 248

1. After cylinder disassembly and assembly the cylinder should be checked for internal and external damage. See "Disassembly and assembly".
2. Pull the entire length of the piston rod out of the cylinder.
3. Connect a test pump with pressure gauge to pipe connection B. Both pump and pressure gauge should be able to handle a minimum pressure of 220 bar.
4. Increase the pressure to the prescribed test pressure, see "Technical data" and leave the cylinder pressurised for some time.  
Never stand in front of the piston rod when increasing the pressure. If the spring clip (6) is not installed correctly, the piston rod could come out of the cylinder.
5. Check the cylinder for internal and external leakage.
6. Push the piston rod completely into the cylinder and plug the pipe connections after completion of the test.

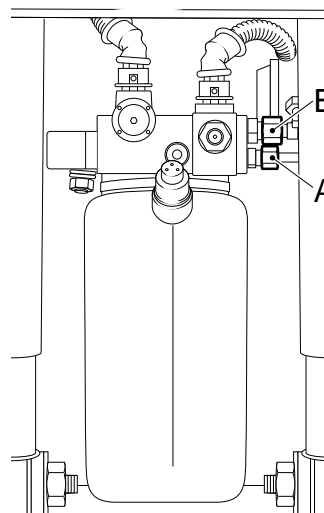

A8 00 281



## 4. REMOVAL AND INSTALLATION

### 4.1 REMOVAL AND INSTALLATION, PUMP UNIT



Before removing components, the component concerned and the pipe connections should be cleaned. Working conditions should be very clean as even the smallest impurity can cause faults.

#### Removing the pump unit

1. The wheels of the trailing axle must rest on the ground.
2. Remove the fuse from the lifting gear.
3. Mark the engine-wiring connection points and disconnect these.
4. Mark the solenoid valve connectors and disconnect these.
5. Remove the hydraulic lines from the pump unit.  
Note: the pipe attached to pipe connection A may retain a residual pressure. Wait for approx. 5 minutes after the trailing axle has been lowered before disconnecting the hydraulic lines from the pump unit. Collect the oil coming from the pipe. Plug the openings.
6. Remove the bolts (5). Remove the support (1) and the attached pump unit (2).
7. Remove the bracket (3).
8. Remove the two attachment bolts (4) and lift the pump unit from the support (1).
9. If a new pump unit is to be installed, the position of line connections (A) and (B) should be marked.

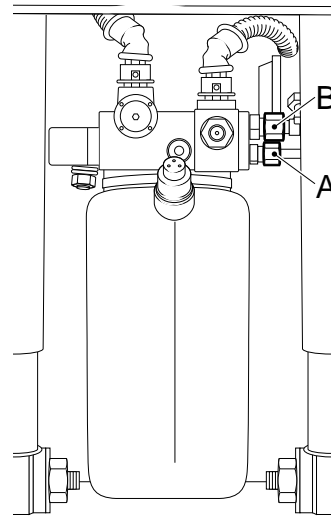

A8 00 281

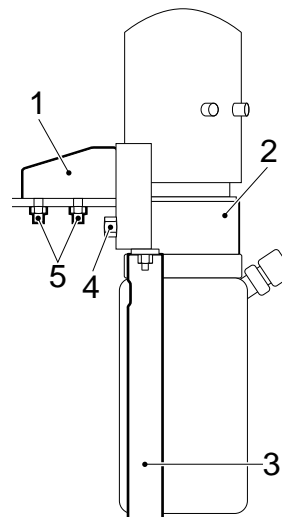

A8 00 287

### Installing the pump unit

1. If a new pump unit is to be installed, the line connections should be transferred. Make sure that the line connections are connected to the correct pump outputs.
  - The line connection which is equipped with M16 x 1.5 screw thread should be fitted to output A.
  - The line connection which is equipped with M18 x 1.5 screw thread should be fitted to output B.
2. Fit the pump unit on its support.
3. Fit the bracket around the reservoir.
4. Fit the support on its chassis cross member.
5. Fit the pipes.
6. Reconnect the wiring and put the fuse back in.
7. Fill the reservoir. See "Draining and filling".
8. Inspect the line connections for leaks.
9. Check the system pressure and the pressure relief valve. See "Inspection and adjustment".

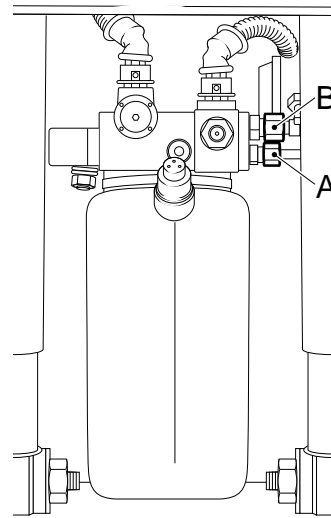

A8 00 281

**4.2 REMOVAL AND INSTALLATION, 4/2 SOLENOID VALVE****Removing the 4/2 solenoid valve**

1. Remove the connector.
2. Clean the valve and the surrounding area.  
Work cleanly.
3. Remove the nut (1) at the valve top and take the coil (4) from the valve.
4. Remove the valve (6) from the valve block.
5. The valve (6) itself cannot be disassembled.

**Installing the 4/2 solenoid valve**

1. Renew the O-rings and the sealing ring.
2. Apply a little oil to the valve (6) and install it into the valve block. Tighten the valve to the specified torque. See "Technical data".
3. Check the O-rings (3) and (5) on the top and bottom of the coil (4) and fit it.
4. Turn the coil (4) into the desired position and fit the spacer ring (2) with the nut (1).
5. Fit the connector.

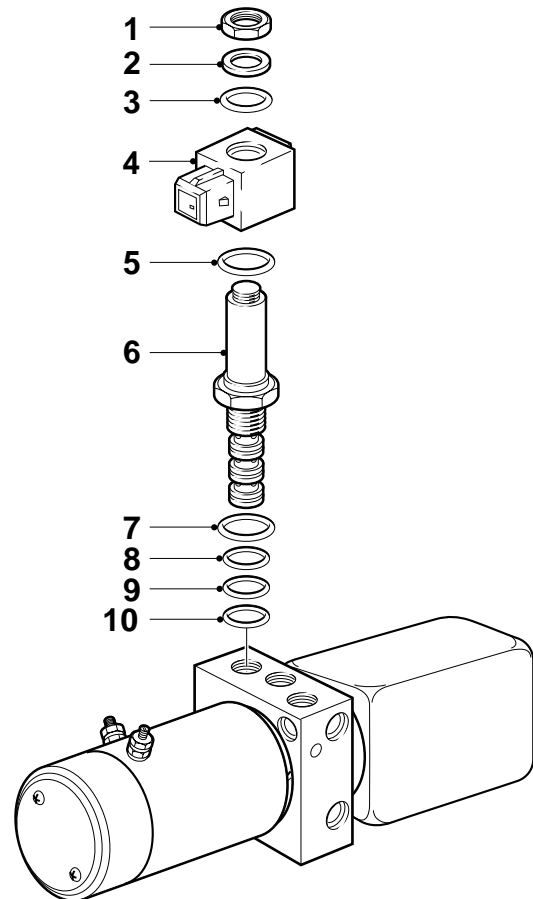

A8 00 252

## 4.3 CHECKING THE FLUID LEVEL IN THE HYDRAULIC LIFTING GEAR

1. Make sure that the trailing axle wheels are fully lowered and on the ground.
2. Check the fluid level. The liquid level must be between the "min." and "max." level mark. If necessary, top up.

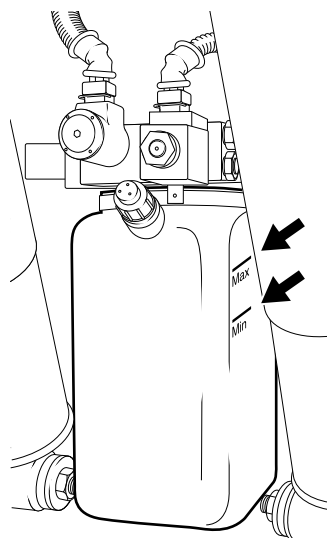

A8 00 282

#### 4.4 REMOVAL AND INSTALLATION, PRESSURE RELIEF VALVE

##### Removing the pressure relief valve

1. Make sure that the trailing axle wheels are fully lowered and on the ground.
2. Clean the valve and the surrounding area. Work cleanly.
3. Remove the fuse from the lifting gear.
4. Remove the entire valve (3) from the valve block.
5. The valve (3) itself cannot be disassembled. If necessary, turn out the hexagonal socket screw until the ball is lifted from its seat. Subsequently purge the valve using compressed air. Before unscrewing the Allen screw, first measure the length of the Allen screw protruding from the valve. After purging the valve, screw the Allen screw into the valve to the same length.

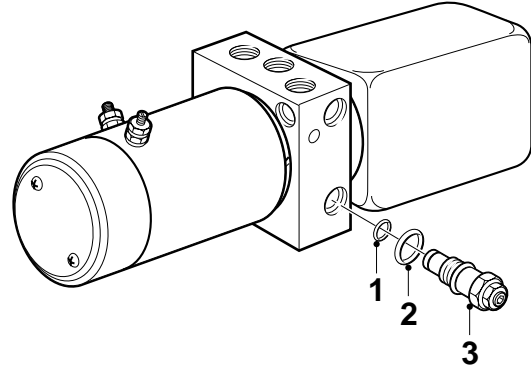

A8 00 276

##### Installing the pressure relief valve

1. Renew the O-rings(1) and (2). Apply a little oil to the valve (3) and install it into the valve block. Tighten the valve to the specified torque. See "Technical data".
2. Install the fuse.
3. Check the pressure and adjust if necessary. See "Inspection and adjustment".

### 4.5 REMOVAL AND INSTALLATION, CYLINDER

#### Removing the cylinder

1. Make sure that the trailing axle wheels are fully lowered and on the ground.
2. Clean the line connections and the surrounding area.
3. Remove the fuse from the lifting gear.
4. Remove the shock absorber next to the cylinder.  
If the cylinder is located on the vehicle's left, the linkage of the load-dependent brake-control valve should also be removed.
5. Remove the lines from the lifting cylinder.  
Note: the line attached to line connection A of the pump unit may retain a residual pressure.  
Wait for approx. 5 minutes after the trailing axle has been lowered before disconnecting the lines.  
Collect the oil coming from the line.  
Plug the openings.
6. Disconnect the lines of the central greasing system, if applicable.

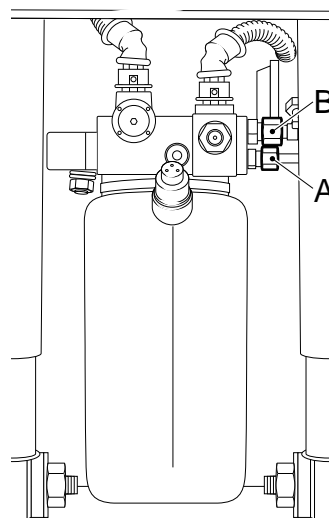

A8 00 281

7. Remove the pin (4) that connects the cylinder (3) with the lever (5).
8. Remove the two bushes from the lever (5). The cylinder will now point downwards, causing part of the oil in the cylinder to flow out.
9. Remove the attachment nut (2) and remove the cylinder (3) from the chassis support (1). Collect the oil still present in the cylinder.

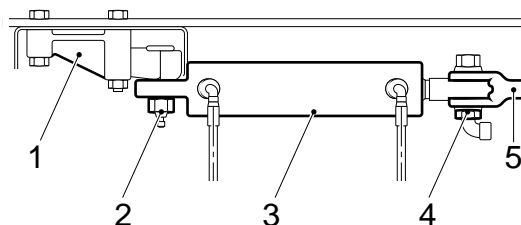

A8 00 283

**Installing the cylinder**

1. Clean the pivot points of the cylinder connection.
2. Grease the chassis support pin. Fit the cylinder on the pin. Hand-tighten the nut onto the pin.
3. Check the bushes (3) and grease them. Fit the bushes (3) to the lever (4).
4. Apply some grease to the connecting pin (6) and install it in the bushes (3) with the nut side pointing towards the chassis members.
5. Fit the lock washer (2) with the nut (1) to the pin (6). Tighten the nut (1) to the specified torque. See "Technical data".
6. Tighten the chassis support nut.
7. Connect the hydraulic lines.
8. Install the shock absorber and, if applicable, the linkage of the load-dependent brake-control valve.
9. Reconnect the lines of the central lubricating system, if applicable.
10. Manually lubricate the turning points, or do so using the central greasing system.
11. Install the fuse.
12. Activate the lifting gear several times. Check the oil level in the reservoir and top up, if necessary. Inspect the line connections for leaks.

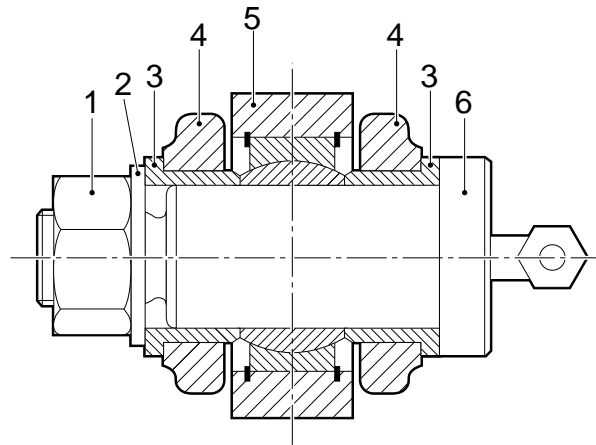

A8 00 284





## 5. DISASSEMBLY AND ASSEMBLY

## 5.1 DISASSEMBLY AND ASSEMBLY, PUMP UNIT

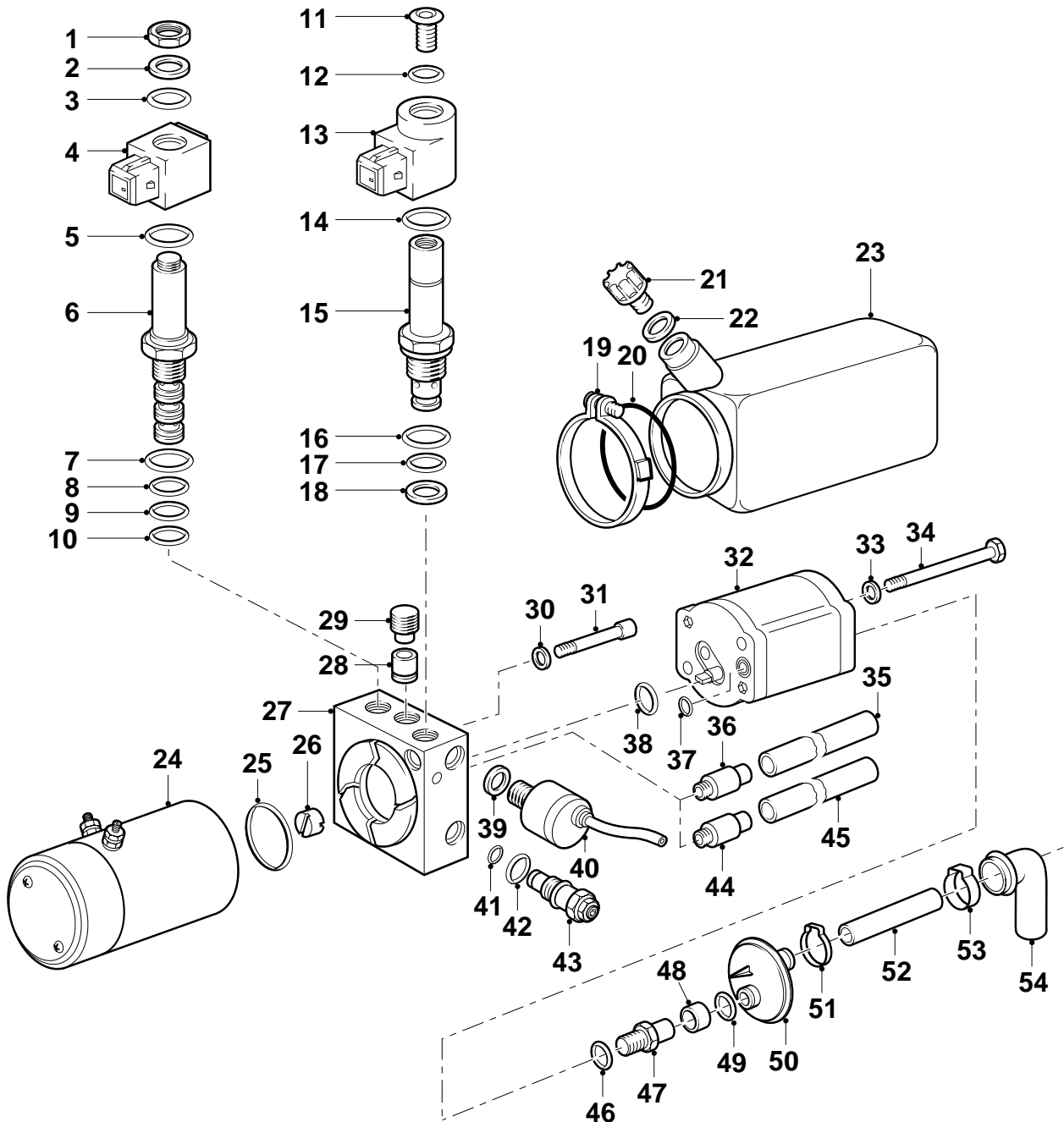

A8 00 277

**Disassembling the pump unit**

1. Remove the pump unit from the vehicle, see the chapter "Removal and installation".
2. Let the oil run from the reservoir.

3. Clean the entire pump unit and the surroundings before disassembly. Work in very clean conditions.
4. Remove the pressure relief valve, the 4/2 valve and the 2/2 valve, see chapter "Removal and installation".
5. The built-in non-return valve (28) is very difficult to remove from the valve block because a very strong locking and sealing compound has been applied to the screw thread of the plug (29). Leave the non-return valve in the valve block, if it is not necessary to remove it.
6. Remove the pressure switch (40).
7. Loosen the clamping strip (19) and take the reservoir (23) from the valve block (27).
8. If necessary, remove the return lines (35) and (45) from the valve block (27). The lines are clamped to the couplings (36) and (44).
9. Loosen the hose clamp (48) and take the suction filter (50) out of the coupling (47).
10. Mark the position of the pump (32) relative to the valve block (27) to facilitate installing the pump. Remove the two attachment bolts (34) at the back of the pump and remove the pump (32) from the valve block (27).
11. Mark the position of the motor (24) relative to the valve block (27). Remove the two hexagonal socket screws (31) and remove the motor from the valve block.
12. Remove the coupling disc (28) from the valve block.

### Assembling the pump unit

1. Check the components for signs of wear and/or damage.  
Check the suction pipe carefully.  
When installing the parts, use new gaskets and/or O-rings. Apply some grease to the O-rings prior to installation.
2. Apply plenty of oil to the coupling disc (26) and install the coupling disc in the valve block (27). Make sure that the groove for the motor is pointing towards the motor side.
3. Install the motor (24) on the valve block (27). Tighten the attachment bolts (31) to the specified torque. See "Technical data".

4. Install the pump (32) on the valve block (27). Make sure that the pump drive shaft engages the coupling disc (26). Check whether the front of the pump is flush against the valve block before tightening the attachment nuts (34). Tighten the attachment bolts to the specified tightening torque, see "Technical data".
5. Install the pressure relief valve, the 4/2 valve and the 2/2 valve, see chapter "Removal and installation".
6. Install the pressure switch (40).
7. Connect the oil return lines (35) and (45).
8. Fit the filter (50). The cam on the filter must fall into the groove of the pump cover. Tighten hose clamp (48) securely.
9. Install the O-ring (20) and the reservoir (23). The filler opening of the reservoir (23) is on the side with the valves (40) and (43). Tighten the reservoir using the clamping strip (19).
10. Plug the line connections.
11. After installation of the pump unit in the vehicle, the operation and adjustment of the valves and the pressure switch should be checked, see chapter "Inspection and adjustment".  
Check for external leakage.

### 5.2 DISASSEMBLY AND ASSEMBLY, 2/2 SOLENOID VALVE



**Disassemble the valve only to check and/or to clean the internals. The internal parts cannot be obtained separately. In case of a fault, the valve as a whole should be replaced. Repair and maintenance activities should be carried out in very clean conditions as even the smallest impurity can cause internal leakage or can result in jamming of the valve.**

#### Disassembling the 2/2 solenoid valve

1. Remove the valve from the pump, see the chapter "Removal and installation".
2. Clamp the valve casing (1) with the hexagonal head in the vice and remove the holder (8).
3. Remove the holder (8) with the valve (7) from the valve casing (1). Make sure that the adjusting rings (3) are kept together.
4. Remove the spring (6) from the magnet-core (4) pin.
5. Remove the magnet core (4) with the bush (5) from the valve casing (1). Note down the distance of the bush (5).

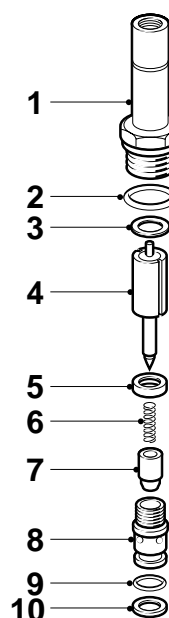

A8 00 254

#### Assembling the 2/2 solenoid valve

1. Check the sealing surfaces of the valve (7), the holder (8) and the magnet-core (4) pin.
2. Check the freedom of movement of the valve (7) in the holder (8).
3. Check the freedom of movement of the pin in the magnet core (4).
4. Replace the O-ring (2) of the valve core (1) and the O-ring (9) of the holder (8). Apply a layer of grease to the O-rings.
5. Install the magnet core (4) with the bush (5) into the valve casing (1). Make sure that the bush (5) is fitted in its original position.

6. Fit the spring (6) on the pin of the magnet-core (4).
7. Oil the valve (7) and slide the valve into the holder (8). Check for freedom of movement.
8. Install the holder (8) with the adjusting ring(s) (3) on the valve casing.
9. Install the valve in the pump unit, see the chapter "Removal and installation".

## 5.3 DISASSEMBLY AND ASSEMBLY, CYLINDER

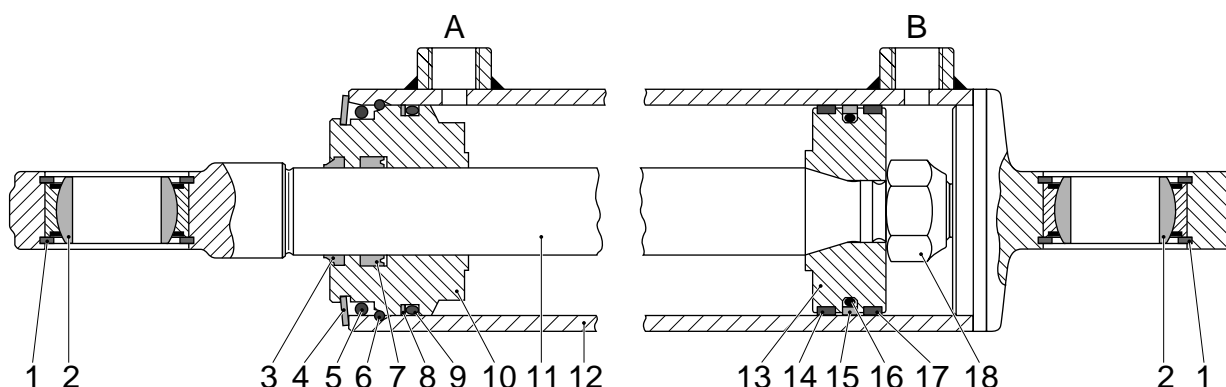

A8 00 248

**Disassembling the cylinder**

1. Remove the cylinder from the vehicle, see the chapter "Removal and installation".
2. Check whether all the oil has been drained from the cylinder.
3. Clean the cylinder before disassembly. Work in very clean conditions. Make sure that the piston rod is not damaged during the repair or maintenance activities.
4. Remove the circlips (1) and push the bearing (2) from the eye.
5. Remove the circlip (4).
6. Remove the dirt which has collected before the O-ring (5) and remove the O-ring (5).
7. Use a plastic mallet to carefully tap the piston-rod guide (10) deeper into the cylinder, until the spring clip (6) can be removed. Make sure that the piston rod is not damaged in the process.
8. Remove the spring clip (6) from the cylinder.
9. Pull the entire length of the piston rod (11) out of the cylinder. The piston-rod guide (10) will come out of the cylinder together with the piston rod.
10. Remove the plastic rings (14) and (16) from the piston.
11. Remove the nut (1) and use a plastic mallet to tap the piston (13) from the piston rod.
12. Slide the piston-rod guide (10), the O-ring (5) and the circlip (4) from the piston rod. Pay attention to the position of the circlip.

13. Remove the dirt scraper (3), the sealing ring (7), the O-ring (9) and the plastic ring (8) from the piston-rod guide.
14. Remove the sealing ring (15) and the underlying O-ring (16) from the piston.

#### Assembling the cylinder

1. Check the sealing-ring chambers and recesses, the dirt scraper and O-rings for impurities.  
Check the surfaces of the piston rod and the cylinder casing for signs of wear and/or damage. Even the slightest damage can cause a leak.  
Check the condition of the spring clip (6) and the circlip (4). Replace if necessary.  
Replace the sealing rings, dirt scraper and O-rings.  
Apply a layer of grease to the O-rings and running surfaces of the sealing rings and dirt scraper prior to assembly.
2. Install the O-ring (16) on the piston (13).
3. Heat the new sealing ring (15) for 5 minutes in water at a temperature of 90°C.
4. Position the special tool (DAF no. 1310472), see "b" in the illustration, on the piston (13).
5. Slide the heated sealing ring (15) onto the piston using the special tool (DAF no. 1310473), see "a" in the illustration.
6. Slide the special tool (DAF no. 1310474), see "c" in the illustration, over sealing ring (15) and leave the special tool on the sealing ring for 5 minutes.

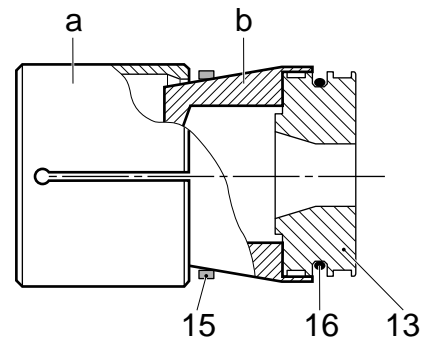

A8 00 260

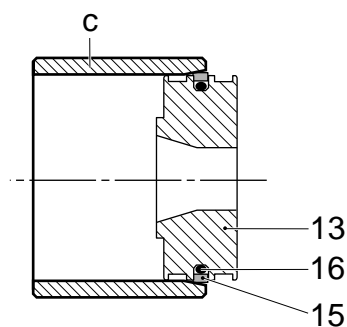

A8 00 261

- Install the sealing ring (7) with the recess aimed towards the piston (13) into the piston-rod guide (10). To do so, press the sealing ring together as shown in the illustration. Make sure that no sharp corners are formed. Subsequently, press the sealing ring into the chamber of the piston-rod guide as shown in the illustration.

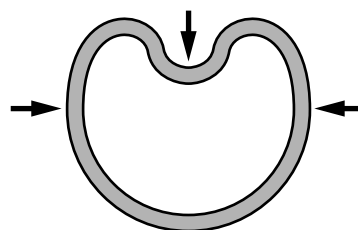

A8 00 262

- Install the dirt scraper (3) into the piston-rod guide (10). You should proceed in the same manner as when installing the sealing ring (7).

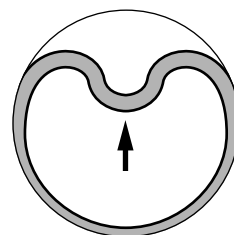

A8 00 263

- Install the plastic ring (8) onto the piston-rod guide (10). You should proceed in the same manner as when installing the sealing ring (15) on the piston.

- Install the O-ring (9) on the piston-rod guide (10). The O-ring should fall into the groove at the piston side. The plastic ring (8) is positioned on the circlip side.

- Slide the circlip (4) into the correct clamping position over the piston rod.

- Slide the O-ring (5) over the piston rod.

- Oil the piston rod (11) and slide the piston-rod guide (10) onto the piston rod.

- Install the piston (13) on the piston rod, replace the self-locking nut (18) and tighten the nut to the prescribed tightening torque, see "Technical data".

- Apply some oil to the cylinder casing.

- Install the plastic rings (14) and (17) on the piston. The gap openings of the rings should be opposite each other. During the installation of the piston in the cylinder, the gap openings may not be positioned near line connection A of the cylinder.

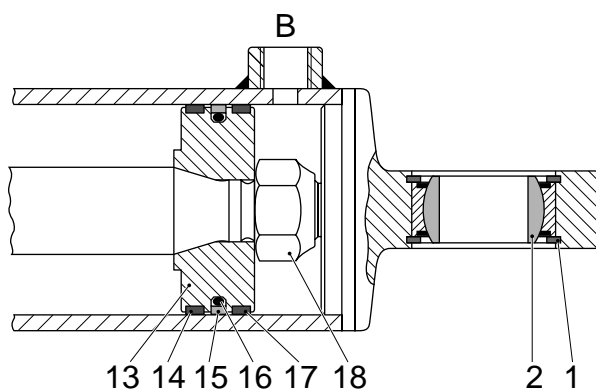

A8 00 286

- Apply some oil to the plastic rings (14) and (17) and the sealing ring (15) and slide the piston into the cylinder. When sliding the piston into the cylinder, the plastic rings should be pressed into the grooves.

- Slide the piston-rod guide (10) into the cylinder and tap the piston-rod guide carefully into the cylinder using a plastic mallet until the spring clip (6) can be fitted. Make sure that the piston rod is not damaged in the process.



19. Fit the spring clip (6) into the cylinder. Make sure that the entire circlip is positioned correctly in the groove.
20. Pull back the piston-rod guide (10) using the piston rod, until the piston-rod guide is in contact with the spring clip (6).
21. Install the O-ring (5).
22. Install the circlip (4). Make sure that the entire circlip is positioned correctly in the groove.
23. Install one of the circlips (1) and press a new bearing (2) into the eye.
24. Install the second circlip (1).
25. Check the cylinder for internal and external leakage, see chapter "Inspection and adjusting".

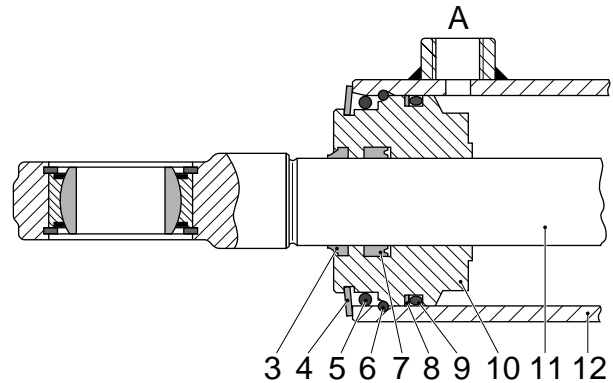

A8 00 285



## 6. DRAINING AND FILLING

### 6.1 FILLING THE HYDRAULIC LIFTING GEAR

1. Make sure that the trailing axle wheels are fully lowered and on the ground.
2. Fill the reservoir with the specified oil up to the "max." level mark.
3. Lift the trailing axle and top up oil to the "min." level mark, if necessary.
4. Lower the trailing axle and, once again, check the level. Top up oil to the "max." level mark, if necessary.



**CONTENTS**

	<b>Page</b>	<b>Date</b>
<b>1. GENERAL</b> .....	1-1 .....	200424
1.1 Description of 09N044 leading rear axle .....	1-1 .....	200424
1.2 Overview drawing, 09N044 leading rear axle .....	1-2 .....	200424
<b>2. INSPECTION AND ADJUSTMENT</b> .....	2-1 .....	200424
2.1 Inspection and adjustment, wheel bearing play, 09N044 leading rear axle .....	2-1 .....	200424
2.2 Checking the hub and wheel bearings .....	2-2 .....	200424
<b>3. REMOVAL AND INSTALLATION</b> .....	3-1 .....	200424
3.1 Removal and installation, wheel hub .....	3-1 .....	200424
3.2 Removal and installation, hub seal .....	3-2 .....	200424
3.3 Removal and installation, wheel bearings .....	3-3 .....	200424



## 1. GENERAL

### 1.1 DESCRIPTION OF 09N044 LEADING REAR AXLE

The 09N044 leading rear axle is a rigid axle. The axle is equipped with air suspension and if the vehicle load admits it, the axle can be raised pneumatically.

The wheel hub has separate wheel bearings that are greased. The wheel bearing play is adjusted using the hub nut, which is secured by a split pin.

1.2 OVERVIEW DRAWING, 09N044 LEADING REAR AXLE

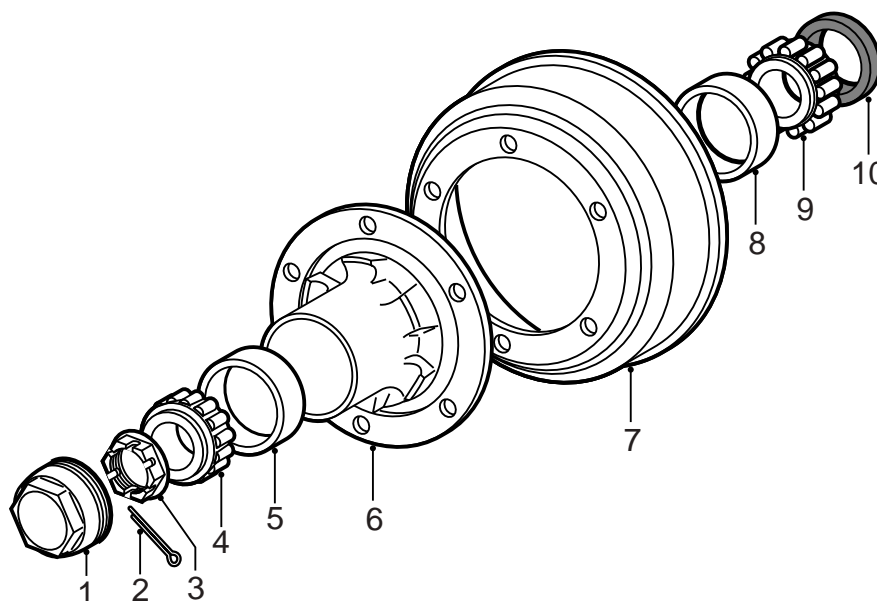

S7 00 640

- 1. Hub cap
- 2. Split pin
- 3. Hub nut
- 4. Bearing cage
- 5. Outer race
- 6. Wheel hub
- 7. Brake drum
- 8. Outer race
- 9. Bearing cage
- 10. Hub oil seal



## 2. INSPECTION AND ADJUSTMENT

### 2.1 INSPECTION AND ADJUSTMENT, WHEEL BEARING PLAY, 09N044 LEADING REAR AXLE

#### Checking the wheel bearing play

1. Remove the hub cap using special tool (DAF no. 1329498).
2. Lift the leading rear axle and support it properly.
3. Release the brakes.
4. Fit a dial gauge; let the stylus rest against the axle journal.
5. Push and pull on the wheel. Read the value off the gauge. Compare this reading to the specified value. See "Technical data". If the reading falls outside the tolerance range, the wheel bearing play should be re-adjusted.
6. Fit the hub cap. Tighten the hub cap to the specified torque using the special tool (DAF no. 1329498), see "Technical data".
7. Adjust the brakes.

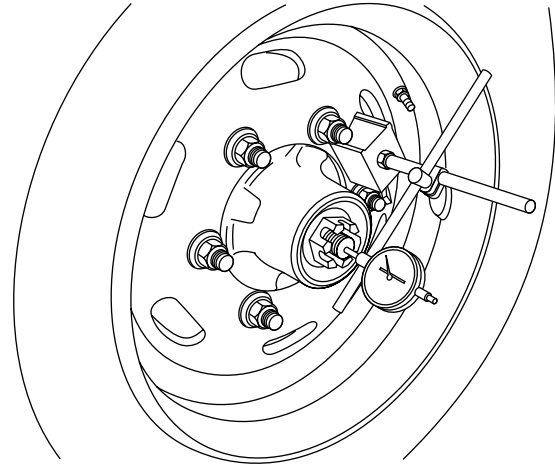

S7 00 635

#### Adjusting the wheel bearing play

1. Remove the hub cap (4) using special tool (DAF no. 1329498).
2. Lift the leading rear axle.
3. Release the brakes.
4. Remove the split pin (3) from the hub nut (2).
5. Tighten the hub nut to the specified tightening torque, see "Technical data". Turn the wheel at least 5 revolutions in anti-clockwise direction and then 5 revolutions in clockwise direction when fixing the hub nut.
6. Check that the wheel rotates smoothly.
7. Turn back the hub nut until the split pin can be fitted. Fit a new split pin.

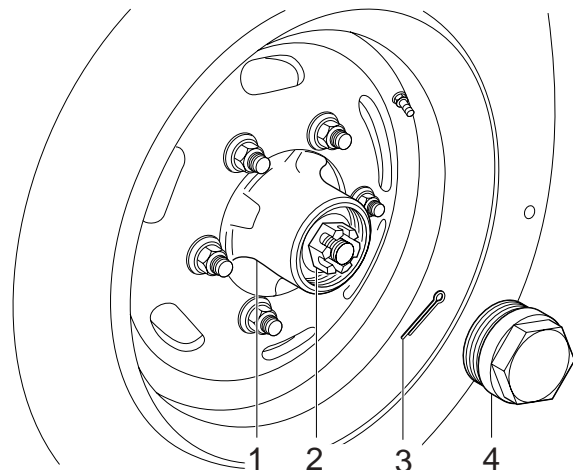

S7 00 657

**Note:**

There are 2 split pin holes in the axle journal. Select the split pin hole where the hub nut needs to be turned back the smallest distance.

8. Check the wheel bearing play. Check the bearings for wear if the wheel bearing play remains too large after adjustment.
9. Fit the hub cap. Tighten the hub cap to the specified torque using the special tool (DAF no. 1329498), see "Technical data".
10. Adjust the brakes.

**2.2 CHECKING THE HUB AND WHEEL BEARINGS**

1. Inspect the bearings for damage at the following points:
  - the roller bearing race,
  - the bearing cage,
  - the raceways of the inner and outer race.If damage is found, the entire bearing (inner race/bearing cage and outer race) should be replaced.
2. If the outer race of the bearing is loose in the hub or has turned in the hub, the hub should be replaced.
3. Check the axle journal screw thread, the bearing surfaces of the inner bearing races and the running surface of the seal for damage.

### 3. REMOVAL AND INSTALLATION

#### 3.1 REMOVAL AND INSTALLATION, WHEEL HUB

##### Removing the wheel hub

1. Remove the hub cap (5) using special tool (DAF no. 1329498).
2. Lift the leading rear axle and support it properly.
3. Remove the split pin (4) and the hub nut (3).
4. Remove the outer wheel bearing (2).
5. Remove the hub (1) with the wheel.

##### Installing the wheel hub

1. Remove the grease from the hub (1).
2. Clean the bearings and liberally re-grease the outer bearing races and bearing cages.
3. Lubricate the space between the wheel bearings with new grease.
4. Install the hub with the wheel.
5. Fit the outer wheel bearing (2).
6. Fit the hub nut (5).
7. Adjust the wheel bearing play, see chapter "Inspection and adjustment".
8. Fit a new split pin (4).
9. Lower the leading rear axle.
10. Fit the hub cap (5) using special tool (DAF no. 1329894). Tighten the hub cap to the specified torque, see "Technical data".
11. Adjust the brakes.

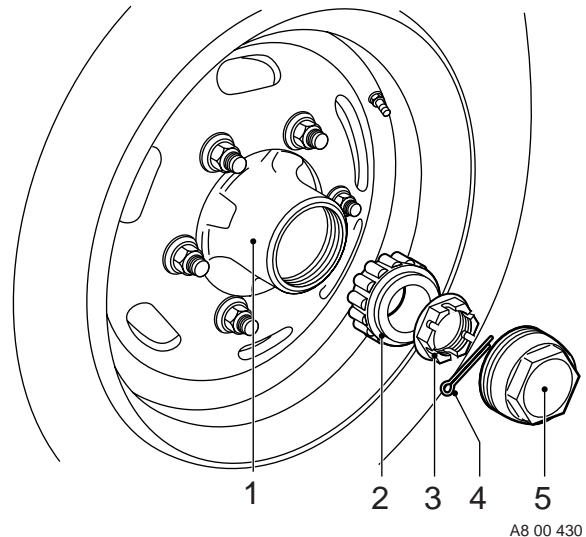

### 3.2 REMOVAL AND INSTALLATION, HUB SEAL

#### Removing the hub seal

1. Remove the wheel hub from the axle journal.
2. Drill two small holes into the seal and screw the special tool (B) (DAF no. 0484899) into the seal. Pull the oil seal from the wheel hub using the special tool (A) (DAF no. 0694928).

#### Installing the hub seal

1. Check the seal chamber for damage.
2. Use the special tool (DAF no. 1329497) to install the seal. Press the seal into the hub.
3. Apply a little grease to the lips of the seal.
4. Install the wheel hub on the axle journal.

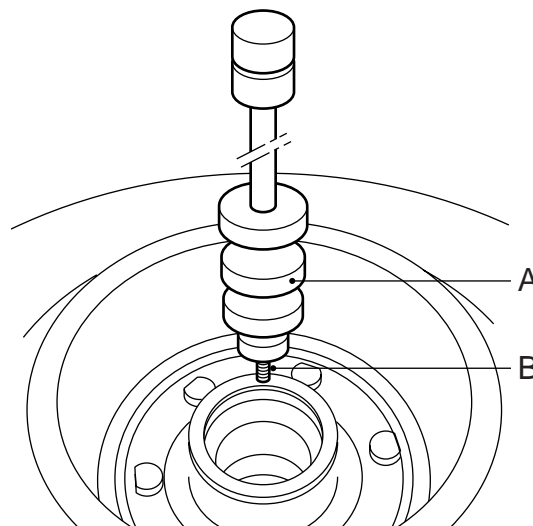

A8 00 432

### 3.3 REMOVAL AND INSTALLATION, WHEEL BEARINGS

#### Removing wheel bearings

1. Remove the hub (3) from the axle.
2. Remove the hub seal (6).
3. Remove the bearing cages (1) and (5).
4. If the wheel bearings should be replaced, the outer bearing races (2) and (4) can be tapped from the hub (3) using a copper driving tool.

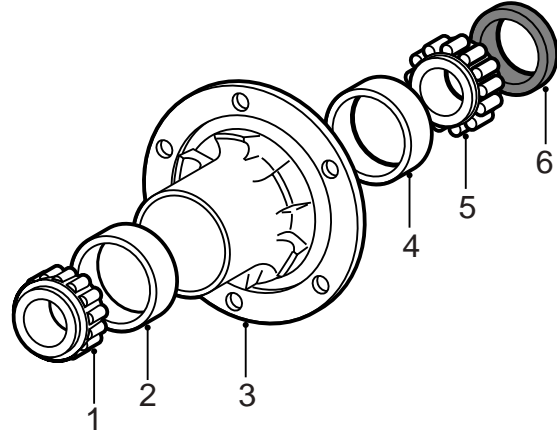

A8 00 431

#### Installing wheel bearings

1. Clean the bearings and check them for signs of damage.
2. Use a driving tool and a hydraulic press to install the new outer bearing races (2) and (4) into the hub (3). Check that the outer races (2) and (4) are pressed into the hub (3) as far as the stop.
3. Apply an ample quantity of new grease to the outer races (2) and (4) and the bearing cages (1) and (5).
4. Lubricate the space between the wheel bearings with new grease.
5. Fit a new hub seal (6).
6. Install the hub (3).

