

TECHNICAL DATA	0
DIAGNOSTICS	1
INTERNAL CAB COMPONENTS	2
CAB HEATING	3
EXTERNAL CAB COMPONENTS	4
CAB SUSPENSION	5
CAB TILTING GEAR	6
SEATS	7
ACCESSORIES	8

CONTENTS

	Page	Date
1. INTERNAL AND EXTERNAL CAB COMPONENTS	1-1	0210
1.1 General	1-1	0210
1.2 Tightening torques	1-8	0210
2. CAB SUSPENSION	2-1	0210
2.1 General	2-1	0210
2.2 Tightening torques	2-3	0210
3. CAB TILTING GEAR	3-1	0210
3.1 General	3-1	0210
3.2 Filling capacities	3-1	0210
4. SEATS	4-1	0210
4.1 General	4-1	0210
4.2 Tightening torques	4-1	0210
5. ACCESSORIES	5-1	0210
5.1 General	5-1	0210
5.2 Tightening torques	5-2	0210

1. INTERNAL AND EXTERNAL CAB COMPONENTS

1.1 GENERAL

Main dimensions and weights

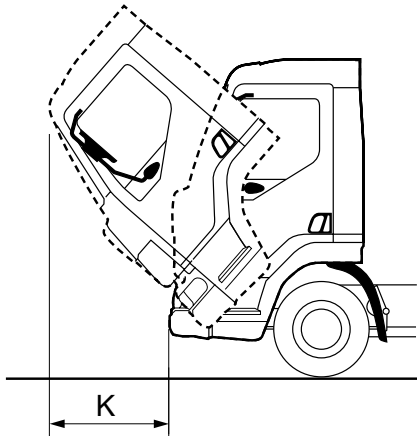

K1 01 170

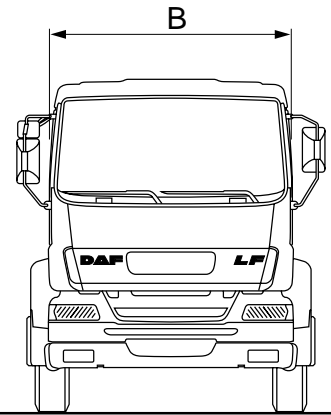
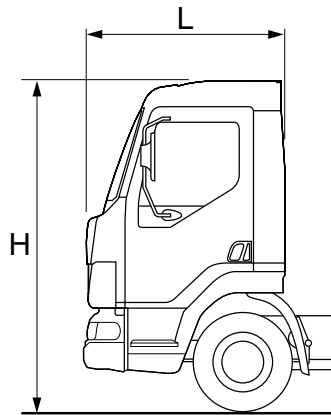

K1 01 192

Cab dimensions in mm:

length (L)
width (B)
max. height (H)
tilting (K)

Day cab

1600 mm
2130 mm
2900 mm ⁽¹⁾
1105 mm ⁽²⁾

Sleeper Cab

2000 mm
2130 mm
2900 mm ⁽¹⁾
1105 mm ⁽²⁾

Cab weights:

Day cab 595 kg
Sleeper cab 750 kg

Notes:

- ⁽¹⁾ Height (H) dependent on version and tyre size
⁽²⁾ Dimension K measured from the front of the bumper.

0

Permissible cab weights:

Roof console evenly distributed

max.

5 kg

Roof evenly distributed

150 kg

Weight on the bunk

125 kg

Cab side members

Welding on cab side members is **NOT** permitted.

When repairing the cab side member, you must use sheet-metal trimming panels. These must be fitted by spot welding.

Straightening dimensions

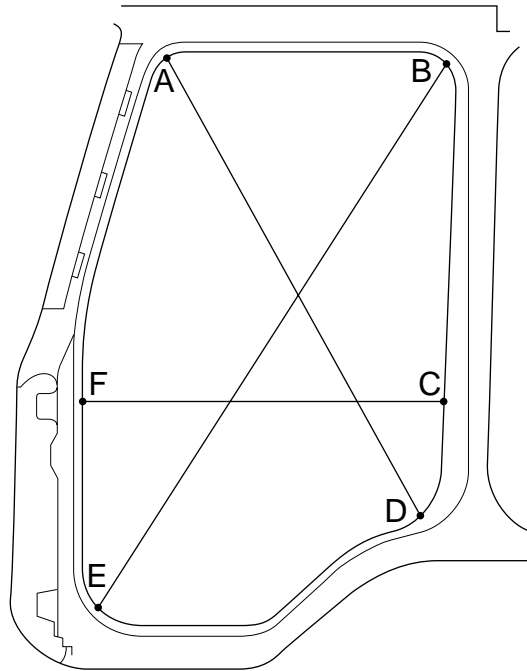

Door opening dimensions

A - D	1283 mm
C - F	887 mm
B - E	1591 mm

0

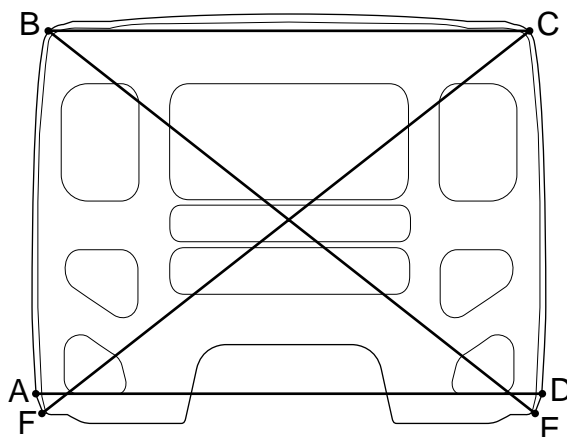

K1 01 208

Rear wall dimensions

A - D	2042 mm
B - C	1926 mm
B - E	2435 mm
C - F	2435 mm

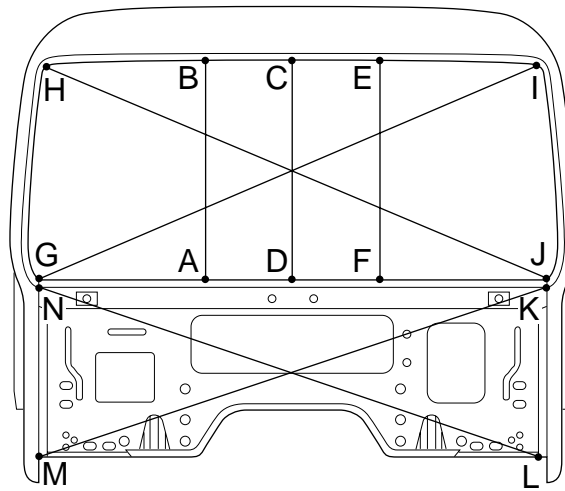

K1 01 210

Cab front dimensions

A - B	836 mm
C - D	836 mm
E - F	836 mm
G - I	1973 mm
H - J	1973 mm

Front panel dimensions

N - L	1945 mm
K - M	1945 mm

Field of vision dimensions

0

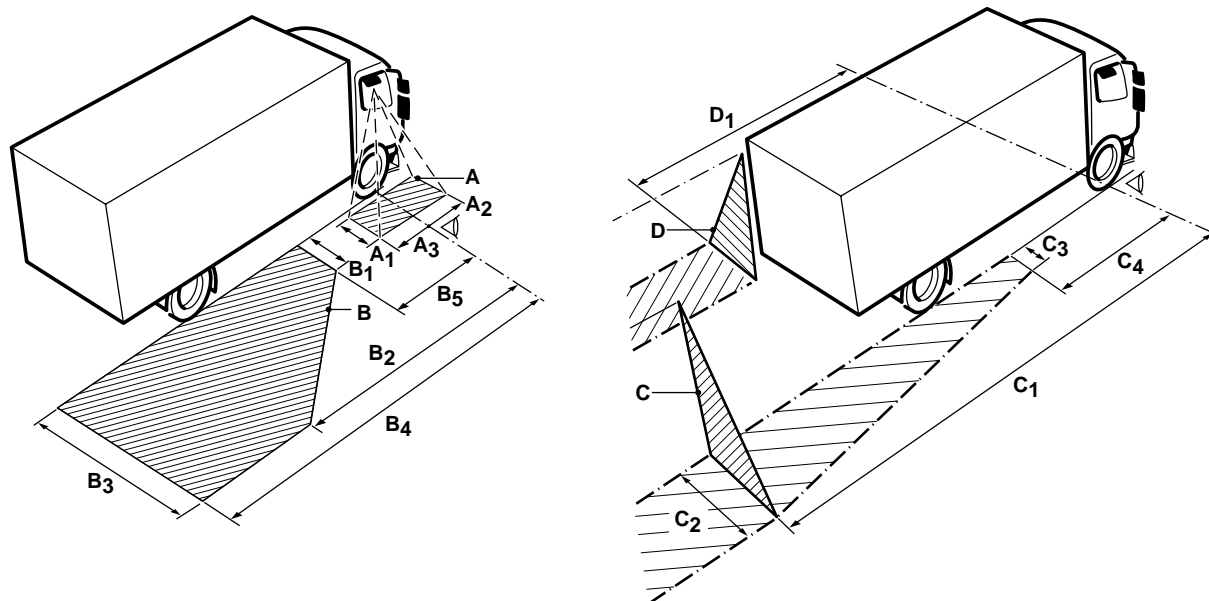

K100237

Mirror	size 1	size 2	size 3	size 4	size 5
Pavement mirror [A]	1 m	1 m	1.25 m		
Wide-angle mirror [B]	2.5 m	15 m	12.5 m	25 m	3 m
Main mirror on co-driver's side [C]	30 m	3.5 m	0.75 m	4 m	
Main mirror on driver's side [D]	10 m	2.5 m			

Windscreens

Curing times for windscreen adhesive				
Product name	DAF number	Vehicle mobile in workshop after:	Cab can be tilted after:	Vehicle usable after:
Sikaflex 255 FC	1271129	6 hours	8 hours	12 hours
Sika Tack Ultrafast	1241020	2 hours	4 hours	6 hours
Sika Tack plus booster	1357925	1 hour	1 hour ⁽¹⁾	2 hours

Notes:

⁽¹⁾ If a vehicle is equipped with an airbag, the curing time is 2 hours

A relative humidity of less than 50% delays curing, as does a temperature lower than 20°C.

Products applied for bonded windscreens			
Product name	DAF number	Properties	Applications
Sikaflex 255 FC	1271129	Processing time 20 min.	Adhesive (cold process) for bonding windscreens
Sika Tack UF	1241020	Processing time 10 min.	Adhesive (warm process) for bonding windscreens
Sika Tack plus booster	1357925	Processing time 10 min.	Adhesive (cold process) for bonding windscreens
Sika Aktivator	1312362		Cleaning fluid for cleaning the glass and the frame.
Sika remover SR 208	1241019		Removal of adhesive which has not yet hardened. Do not use on surfaces to be bonded.

0

1.2 TIGHTENING TORQUES

The tightening torques stated in this paragraph are different from the standard tightening torques stated in the overview of the standard tightening torques. The other threaded connections which are not stated must therefore be tightened to the tightening torque stated in the overview of standard tightening torques.

When attachment bolts and nuts are to be replaced, it is important - unless stated otherwise - that these bolts and nuts are of exactly the same length and property class as the removed ones.

Steering wheel

Steering wheel attachment bolt	50 ± 5 Nm
--------------------------------	-----------

Universal joint

Universal joint attachment bolt	56 ± 5.6 Nm ⁽¹⁾
---------------------------------	----------------------------

Airbag

Airbag module attachment bolt	5 ± 1 Nm
Contact unit attachment bolt	1.2 Nm
Electronic unit	10 ± 2 Nm

Note:

⁽¹⁾ Always replace the attachment bolt and nut.

2. CAB SUSPENSION

2.1 GENERAL

The day cab can be fitted with rubber spring elements at the front. The version with rubber spring elements at the front does not have a stabiliser.

The coil spring elements are fitted with shock absorbers.

The length of the spring elements and the cab height cannot be adjusted.

On models equipped with coil spring elements at the front, a difference in cab height can be corrected to a certain extent using the stabiliser bar.

At the rear, coil springs are used. The length of the spring elements varies depending on whether a day cab or a sleeper cab is involved.

Cab support, general

The distance between the cab supports (A) measured from the left side of the left support to the left side of the right support is:

1000 mm

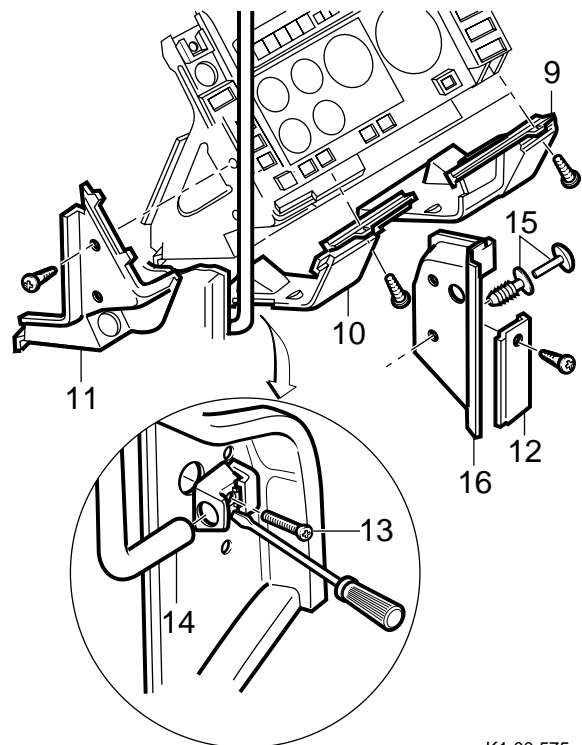

K1 00 575

TECHNICAL DATA

1

Cab suspension

LF45/55 series

0

Cab support with silentblock

Silent block mounting angle (A)

67° - 71°

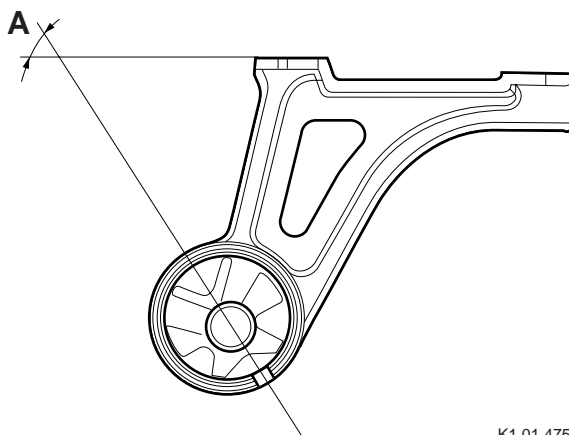

K1 01 475

Cab support with coil spring suspension

Silent block mounting angle (A)

18° - 22°

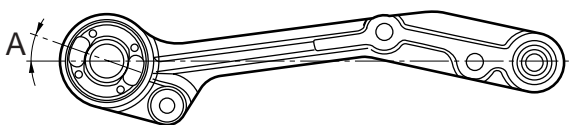

K1 01 442

2.2 TIGHTENING TORQUES

The tightening torques stated in this paragraph are different from the standard tightening torques stated in the overview of the standard tightening torques. The other threaded connections which are not stated must therefore be tightened to the tightening torque stated in the overview of standard tightening torques.

When attachment bolts and nuts are to be replaced, it is important - unless stated otherwise - that these bolts and nuts are of exactly the same length and property class as the removed ones.

Attachment bolts for cab suspension using coil springs

Cab suspension attachment bolt	250 Nm + 150° angular displacement
--------------------------------	------------------------------------

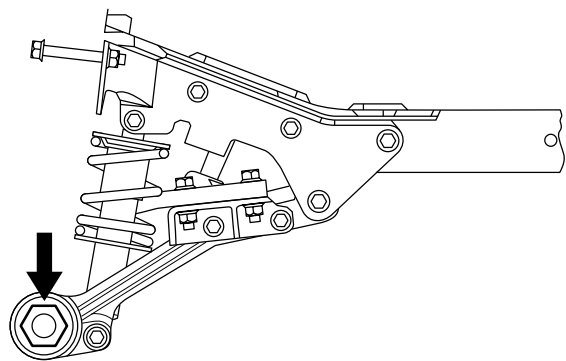

K1 01 573

Attachment bolts for cab suspension using rubber spring elements

Cab suspension attachment bolt	250 Nm + 150° angular displacement
--------------------------------	------------------------------------

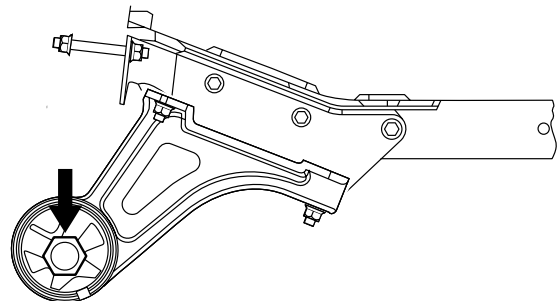

K1 01 574

3. CAB TILTING GEAR

3.1 GENERAL

Lifting cylinder

Nominal pressure 250 bar

Cab tilting pump

Nominal pressure 250 bar

Pressure limiting valve 350 + 30 bar

3.2 FILLING CAPACITIES

Cab tilting pump

Effective oil capacity of the cab-tilting pump. 200 cm³

4. SEATS

4.1 GENERAL

Height control valve

Adjusting dimension X for height control valve 1 - 2 mm

4.2 TIGHTENING TORQUES

The tightening torques stated in this paragraph are different from the standard tightening torques stated in the overview of the standard tightening torques. The other threaded connections which are not stated must therefore be tightened to the tightening torque stated in the overview of standard tightening torques.

When attachment bolts and nuts are to be replaced, it is important - unless stated otherwise - that these bolts and nuts are of exactly the same length and property class as the removed ones.

M8 attachment bolt	22 Nm
M10 attachment bolt	22 Nm
Attachment bolt 7/16" UNF-2B	37 Nm

5. ACCESSORIES

5.1 GENERAL

Roof spoiler

Adjusting range of roof spoiler, aerodynamic and adjustable

350 - 850 mm

Note:

The roof spoiler height can be adjusted using adjusting mechanism (B).
The size is the distance measured between the highest roof spoiler edge (P) and the cab roof plate local to the vehicle centreline.

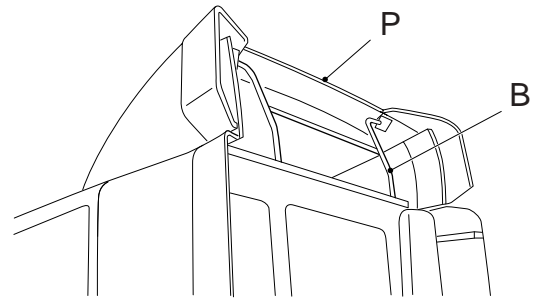

K1 01 355

Application compounds for rear air foils and roof spoilers

Product name	DAF number	Properties	Applications
Sikaflex 252 (white)	1286578	Working time within 15 min. Curing time 2 days	Kit for fender and roof spoiler attachment



5.2 TIGHTENING TORQUES

The tightening torques stated in this paragraph are different from the standard tightening torques stated in the overview of the standard tightening torques. The other threaded connections which are not stated must therefore be tightened to the tightening torque stated in the overview of standard tightening torques.

When attachment bolts and nuts are to be replaced, it is important - unless stated otherwise - that these bolts and nuts are of exactly the same length and property class as the removed ones.

Roof spoiler

Attachment nuts	13 Nm
-----------------	-------

Rear air foil

Attachment nuts	13 Nm
-----------------	-------

Sun visor

Bracket attachment bolts	13 Nm
Bolt for attaching the sun visor to the bracket	10 Nm

CONTENTS

	Page	Date
1. CAB SUSPENSION	1-1	0210
1.1 Fault-finding table, cab tilting mechanism	1-1	0210



1. CAB SUSPENSION

1.1 FAULT-FINDING TABLE, CAB TILTING MECHANISM

COMPLAINT: TILTING CYLINDER FAILS TO RESPOND	
Possible cause	Remedy
Damaged or broken pipe.	Replace pipe or connection.
Pump reservoir empty.	Top up reservoir and check for leakage.
Worn or damaged cylinder seal.	Replace the cylinder or seal.

COMPLAINT: PUMP ROD REBOUNDS	
Possible cause	Remedy
Leaking non-return valve.	Disassemble the two-way valve of the pump. Clean and degrease the valve components. Replace all seals and assemble the two-way valve.

COMPLAINT: PUMP ONLY FUNCTIONS IN THE LAST PART OF THE STROKE	
Possible cause	Remedy
Low oil level in oil reservoir.	Top up oil reservoir.
Leaking inlet valve (ball).	Remove the two-way valve and check the inlet valve. Clean or replace it.
Polluted inlet strainer.	Clean the reservoir and strainer.

COMPLAINT: PUMP FAILS TO BUILD UP PRESSURE	
Possible cause	Remedy
Reservoir level too low.	Top up the reservoir.
Leaking inlet valve (ball).	Remove the two-way valve and check the inlet valve. Clean or replace it.
Worn or damaged O-rings on the two-way valve.	Remove the two-way valve and replace all seals and O-rings.
Pressure-relief valve incorrectly set.	Check the pressure relief valve and adjust, if necessary.

COMPLAINT: CAB LOCK CANNOT BE OPENED

Possible cause	Remedy
Damaged or broken pipe.	Replace pipe or connection.
Jammed piston in locking mechanism.	Repair or replace the locking mechanism.

COMPLAINT: CAB CANNOT BE TILTED

Possible cause	Remedy
Jammed piston in cab locking mechanism.	Repair or replace the locking mechanism.
Pump fails to build up pressure.	Check the operation of the pump.

CONTENTS

	Page	Date
1. SAFETY INSTRUCTIONS	1-1	0210
2. GENERAL	2-1	0210
2.1 Overview drawing, interior cab components	2-1	0210
2.2 System description, steering column	2-2	0210
3. INSPECTION AND ADJUSTMENT	3-1	0210
3.1 Inspection, steering column setting valve	3-1	0210
4. REMOVAL AND INSTALLATION	4-1	0210
4.1 Removal and installation, switches	4-1	0210
4.2 Removal and installation, dashboard panels	4-2	0210
4.3 Removal and installation of complete dashboard	4-9	0210
4.4 Removal and installation, pneumatic switch/valve of steering column adjustment unit	4-15	0210
4.5 Removal and installation, steering column	4-17	0210
4.6 Removal and installation, steering wheel	4-22	0210
4.7 Removal and installation, door panel	4-26	0210
4.8 Removal and installation, manually operated window mechanism	4-28	0210
4.9 Removal and installation, electrically operated window mechanism	4-29	0210
4.10 Removal and installation, roof console	4-30	0210
4.11 Removal and installation, interior lighting	4-31	0210
4.12 Removal and installation, ignition lock	4-31	0210
4.13 Removal and installation, complete door lock mechanism	4-32	0210
4.14 Removal and installation, door lock cylinder	4-34	0210
4.15 Removal and installation, engine brake switch	4-34	0210
4.16 Removal and installation, rear wall lining	4-35	0210
4.17 Removal and installation, roof lining	4-36	0210
4.18 Removal and installation, side wall lining	4-37	0210
4.19 Removal and installation, storage trays (sleeper cab)	4-37	0210

1. SAFETY INSTRUCTIONS

General

The cab is equipped with a hydraulic tilting mechanism. The pump is located on co-driver's side at the rear of the cab. The cab locks are opened hydraulically during pumping. Before tilting the cab, make sure that the doors are closed, that there are no loose items in the cab and that the gear lever is in neutral. Tilt the cab fully forward if work must be carried out underneath the cab.



You can stop the cab tilting forward at any time by turning the tap to the reverse tilting position.



When working on a tilted cab (for example when welding, spray-painting or applying bitumen coatings), be sure to cover the piston rod of the lifting cylinder. Welding spatter and paint on the piston rod will inevitably cause damage to the oil seal.

Inspection after a collision

Before tilting the cab after a collision, check the cab rests, the cab hinges and the attachment of the lifting cylinder to the chassis member and cab for cracks.



If the vehicle has been involved in a collision, the cab must under no circumstances be tilted without due precautions. The end stop in the lifting cylinder may be damaged, which might cause the cab to shoot past its end stop.

If possible, suspend the cab in slings and put a stand in front of the cab. Make sure that there is no one in front of the cab while it is being tilted.

Replacing the lifting cylinder

After a collision, **always** check the lifting cylinder for internal damage.

Replace the lifting cylinder if damaged or if you are in doubt as to its condition.

Always replace the cylinder if one of the following points has occurred during a collision:

- A. the cab has been pulled out of the cab locks,
- B. the cab locks have been deformed or damaged,
- C. the rear cab springs have been deformed or damaged.

Airbag and seat belt tensioner safety instructions

- Never disconnect an electrical connection in the airbag or seat belt tensioner circuits with the ignition switched on.
- All work on pyrotechnic systems (systems with airbag(s) and/or seat belt tensioner(s)) may only be carried out by employees of approved DAF dealers or workshops who are sufficiently trained on these systems.
- The use of pyrotechnic systems (systems with airbag(s) and/or seat belt tensioner(s)) is subject to various national laws. The legal stipulations must be observed.

- Vehicles equipped with a pyrotechnic system (system with airbag(s) and/or seat belt tensioner(s)) can be identified by a sticker with an airbag symbol on the windscreen and/or with the word AIRBAG on the airbag unit on the steering wheel.
- If the vehicle is equipped with an airbag and seat belt tensioner system while there is no airbag symbol on the windscreen, this symbol will have to be applied as yet.

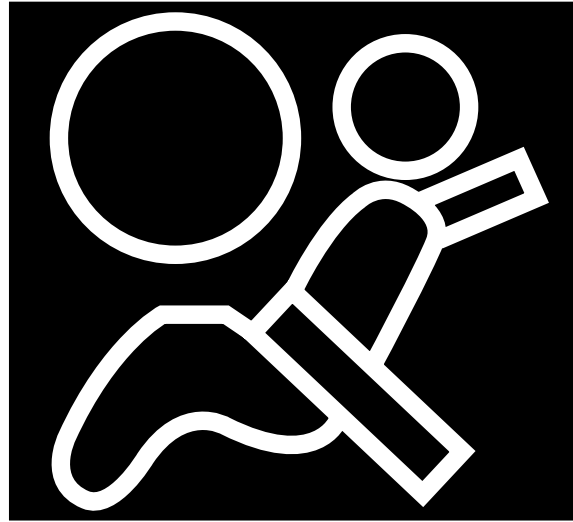

K101290

- It is not permitted to install accessories on airbag and seat belt tensioner parts or in their operating zones afterwards. The operating zone covers an area the size of a ball with a diameter of 80 cm. Only accessories approved by DAF for vehicles with an airbag and/or seat belt tensioner may be installed, in the place indicated by DAF and in the manner outlined by DAF.
- Using equipment or objects that generate strong electromagnetic fields in the vicinity of parts of the airbag/seat belt tensioner system can lead to unwanted activation of the airbag and/or seat belt tensioner or can make proper operation of the system impossible. The use of such equipment or objects in the vicinity of parts of the airbag/seat belt tensioner system is therefore not recommended.

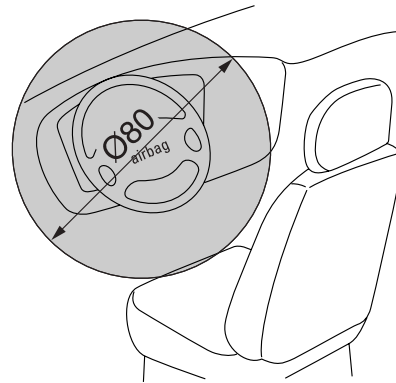

G0 00 235

- It is not allowed to leave pyrotechnic units (airbags and/or seat belt tensioners) unattended. If repairs to a vehicle continue for a long time and pyrotechnic units (airbags and/or seat belt tensioners) are involved in the repair, the pyrotechnic units must be stored safely (under lock and key). This means that the storage location must meet local requirements relating to pyrotechnic materials. The pyrotechnic units may not be stored together with different hazardous substances and the location must have the relevant hazard warning symbols and fire protection facilities.
- Before any work is carried out on a pyrotechnic part (airbag and/or seat belt tensioner):
 - a. switch off the ignition.
 - b. the negative battery terminal clamp must be separated carefully.
 - c. wait at least 5 minutes.
- If pyrotechnic units have been activated in a crash, the electronic unit and the contact unit must be replaced in addition to the pyrotechnic units. The cable harness assembly and connectors must be inspected visually. If damage or overload is established, the cable harness assembly must be replaced.

2. GENERAL

2.1 OVERVIEW DRAWING, INTERIOR CAB COMPONENTS

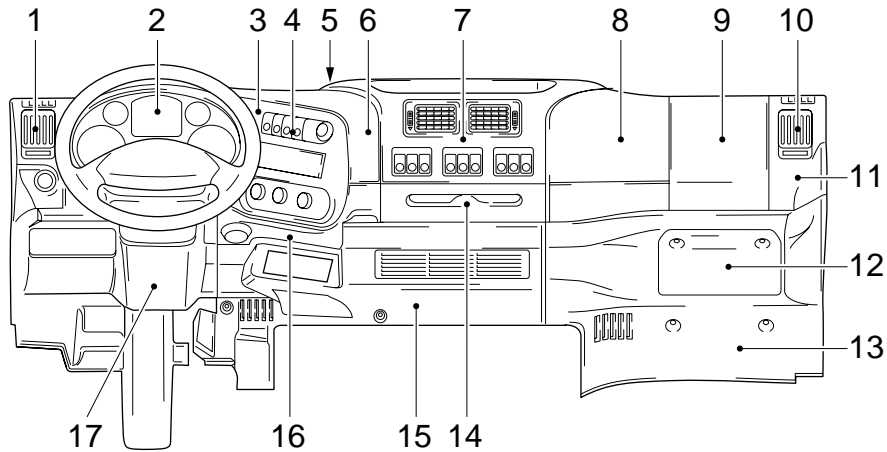

K1 01 438

Legend

1. Left-side ventilation grille
2. Instrument panel
3. Garnish moulding
4. Radio panel
5. Frame rim cover panel
6. Upper dashboard panel on driver's side
7. Central console control panel
8. Upper side of cover panel
9. Upper side of cover
10. Right-side ventilation grille
11. Right-side dashboard panel
12. Lid on central box
13. Lower dashboard panel on co-driver's side
14. Ashtray
15. Engine tunnel dashboard panel
16. Lower dashboard panel on driver's side
17. Steering column dashboard panel

2.2 SYSTEM DESCRIPTION, STEERING COLUMN

The tilting angle of the steering column can be adjusted manually or pneumatically. A spring-loaded clamping mechanism fixes the steering column in position.

The pneumatically adjusted steering column is unlocked using the air cylinder behind the steering column.

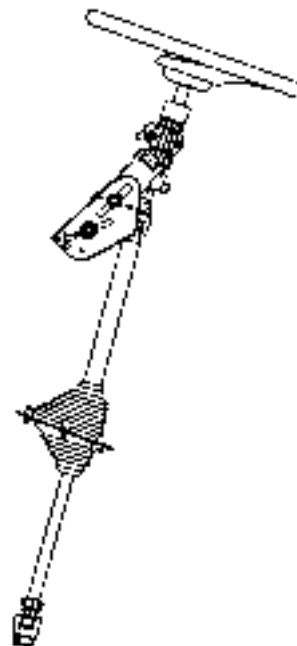

K1 01 425

The operating valve (switch) is situated behind the driver's seat. This valve can be operated by the heel.

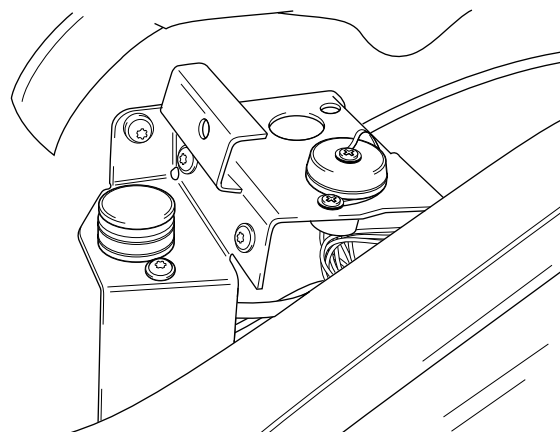

K1 01 202

3. INSPECTION AND ADJUSTMENT

3.1 INSPECTION, STEERING COLUMN SETTING VALVE

1. Check whether the angle of the steering column can be adjusted, once the switch is pressed in with the heel.
2. Check that the adjustment mechanism is securely locked again when the switch is released.
3. If this is not the case, check that no air pipe is trapped. If not, replace the valve (switch).

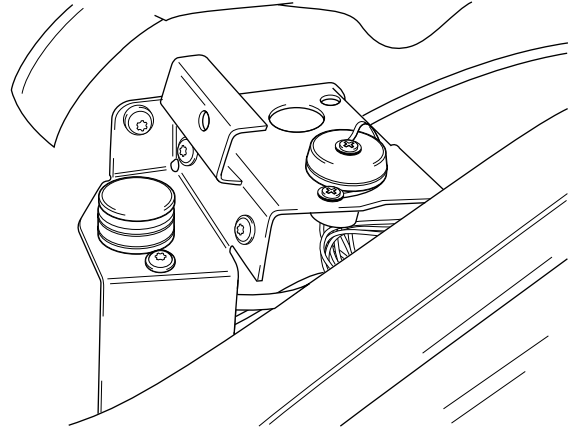

K1 01 202

4. REMOVAL AND INSTALLATION

4.1 REMOVAL AND INSTALLATION, SWITCHES

Removing switches

1. Insert a feeler gauge of approx. 1 mm straight between the switch and the panel at the side of the finger-sized depression (A), until it touches the inside of the panel.
2. Remove the switch from its locked position by carefully moving the feeler gauge in the direction of the arrow (B).
3. Carefully remove the switch from the panel. In doing so, ensure that the connector lock does not catch behind the panel, causing the connector to fall behind the panel.
4. If necessary, remove the switch from the connector.

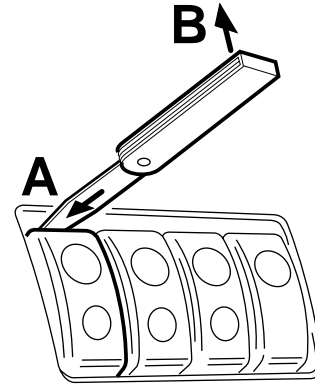

K1 01 186

Installing switches

1. Fit the connector.
2. Insert the switch into the opening in the panel and press until you can feel it lock.

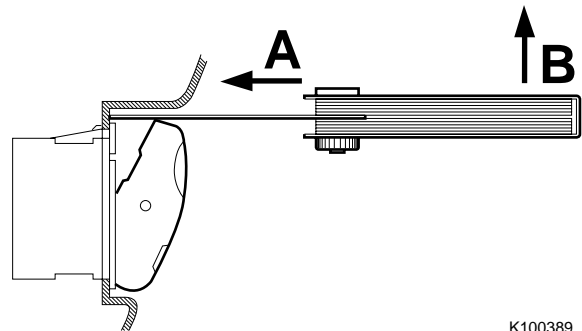

K100389

4.2 REMOVAL AND INSTALLATION, DASHBOARD PANELS

Note:

Dashboard panel removal and installation is listed in the correct sequence. To allow each following panel to be removed, the earlier specified panels must be removed first.

Removing steering column dashboard panel

1. If necessary, remove the floor mat.
2. Using the steering column setting, move the steering wheel to its highest possible position.
3. Remove the attachment bolts (1) and panel plug (2) and subsequently the steering column dashboard panel.

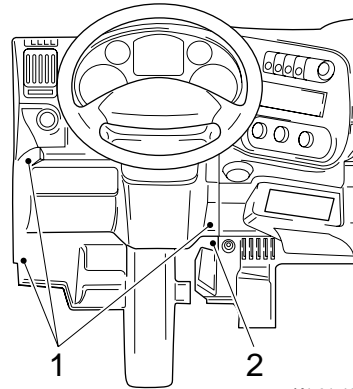

K1 01 427

Removing the lower dashboard panel on co-driver's side

1. Remove the attachment bolts from the lower dashboard panel on co-driver's side. Remove the lower dashboard panel on co-driver's side

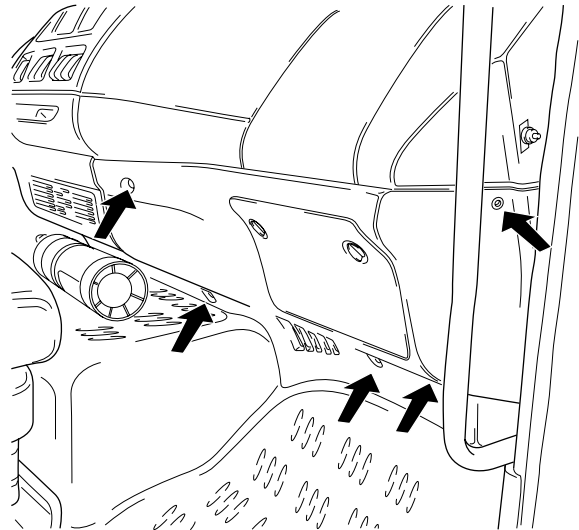

K1 01 428

Removing the engine tunnel dashboard panel

1. Remove the attachment bolts (1) and the panel plugs (2). Remove the engine tunnel cover panel.
2. Loosen the 12V power supply connector at the rear.

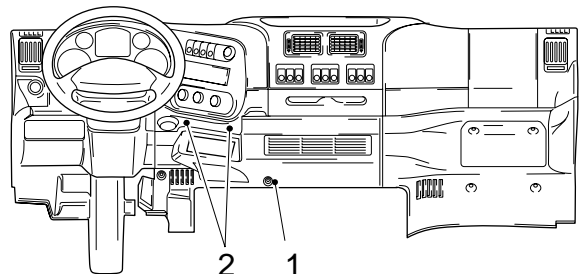

K1 01 429

Removing the instrument panel

1. Remove the attachment bolts (1) of the garnish moulding (2) around the instrument panel (3).
2. Carefully pull the mounting clips (see arrows) holding down the garnish moulding (2) from the dashboard panel.
3. Remove the attachment bolts from the instrument panel (3).
4. Remove the instrument panel (3).
5. Remove the connector from the instrument panel (3).

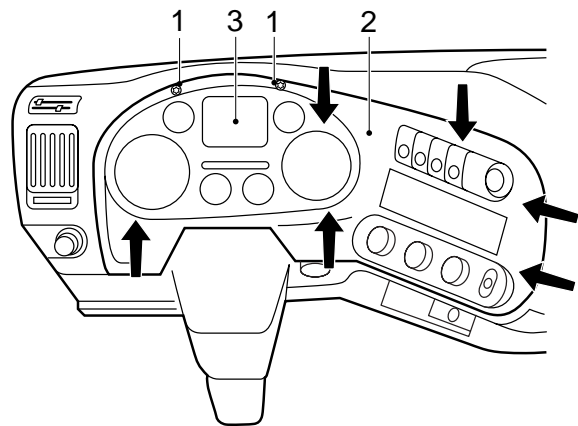

K1 01 430

Removing the lower dashboard panel on driver's side

1. Remove the attachment bolts (1). Remove the dashboard panel.
2. Loosen the headlamp height adjustment connector at the rear.
3. Remove the attachment bolts from the connector block at the rear of the dashboard panel.
4. Remove the connector block.

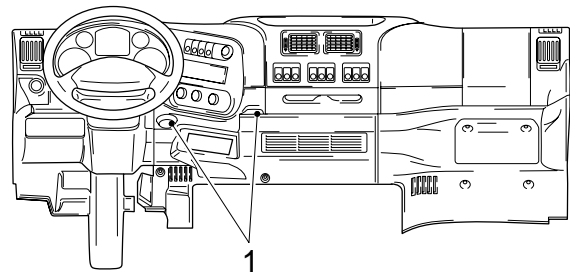

K1 01 431

Removing the window frame cover panel

1. Remove the attachment bolts (1) from the window frame.
2. Take the cover panel out of the window frame.

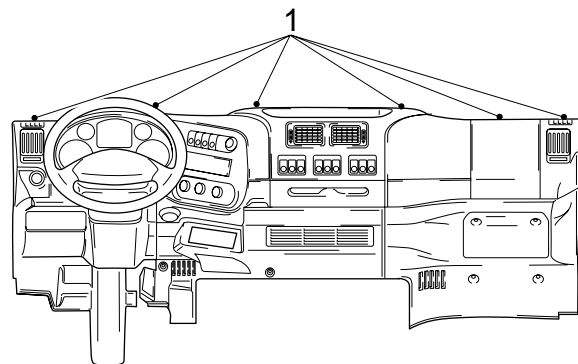

K1 01 432

Removing the upper cover

1. Remove the attachment bolts at the bottom of the cover.
2. Remove the cover from the upper cover panel by tilting it upwards.

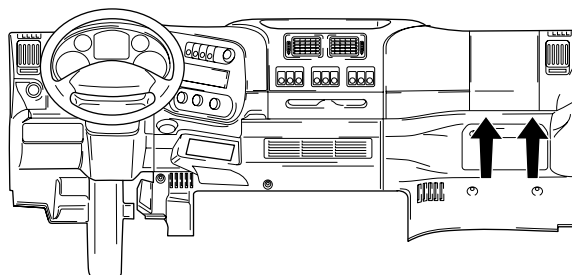

K1 01 433

2

Removing the central console control panel

1. Remove the switches (3) from the control panel in the central console (5).
2. Remove the ashtray (2) from the control panel in the central console (5).
3. Remove the attachment bolts (1) from control panel in the central console (5).
4. Remove the control panel from the central console (5).
5. Disconnect the connector of the cigarette lighter (4).

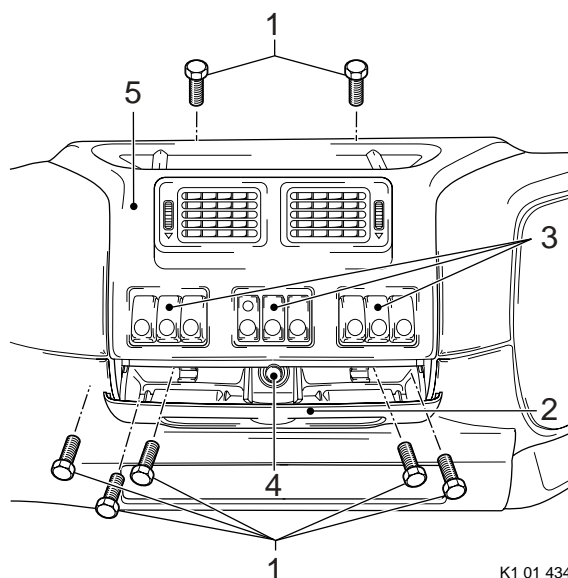

K1 01 434

Removing the right-side dashboard panel

1. Remove the dashboard panel attachment bolts.
2. Remove the connector from the stepwell lighting door switch

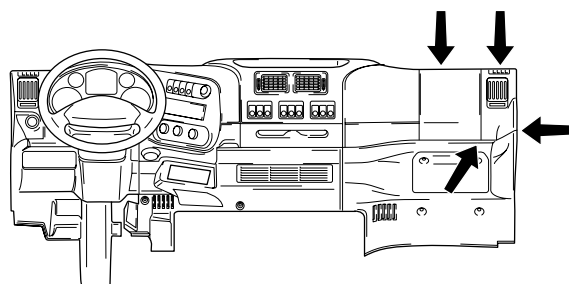

K1 01 435

Removing the upper dashboard panel on driver's side

1. Remove the attachment bolts (1) from the radio panel (2).
2. Remove the attachment bolts (3) from the dashboard panel.
3. Cut the cable binders that are used to attach the wiring harnesses to the dashboard panel.
4. Remove the dashboard panel. Unhook the radio panel (2) from the dashboard panel.
5. Disconnect the connector of the light switch (4) and the stepwell lighting door switch.

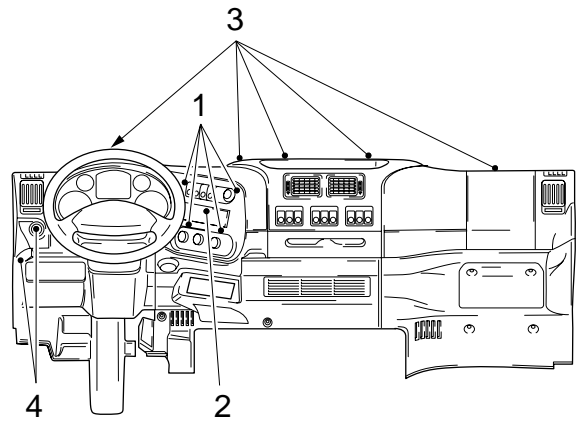

K1 01 436

Installing the upper dashboard panel on driver's side

1. Fit the connector of the light switch (4) and the stepwell lighting door switch.
2. Fit the dashboard panel. Hook the radio panel (2) to the dashboard panel.
3. Fix the removed cable harnesses to the dashboard panel using cable binders.
4. Fit the dashboard panel attachment bolts (3).
5. Fit the attachment bolts (1) of the radio panel (2) to the dashboard panel.

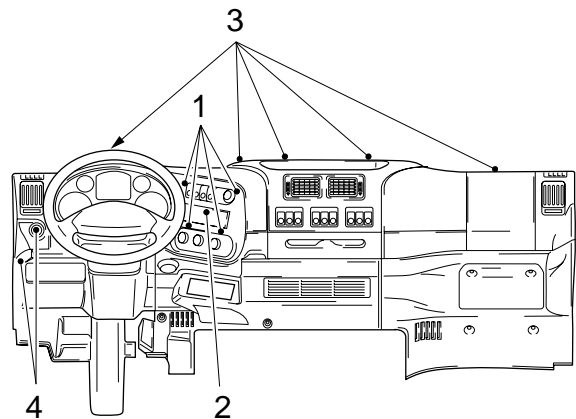

K1 01 436

Installing the right-side dashboard panel

1. Fit the connector of the stepwell lighting door switch to the right-side dashboard panel
2. Fit the right-side dashboard panel using the attachment bolts.

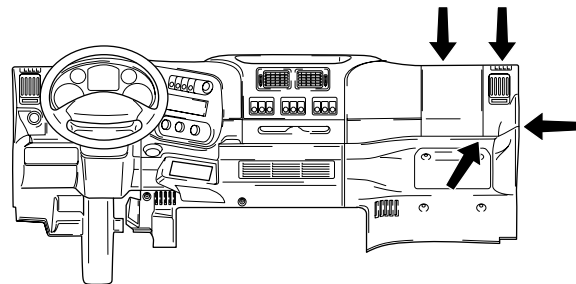

K1 01 435

Installing the central console control panel

1. Re-fit the connector of the cigarette lighter (4) to the rear of the control panel of the central console (5).
2. Fit the control panel of the central console (5) to the dashboard.
3. Hook up the switches (3) from the control panel in the central console (5) to the connectors. Re-fit the switches (3) to the control panel in the central console (5).
4. Secure the control panel in the central console (5) using the attachment bolts (1).
5. Fit the ashtray (2) into the control panel in the central console (5).

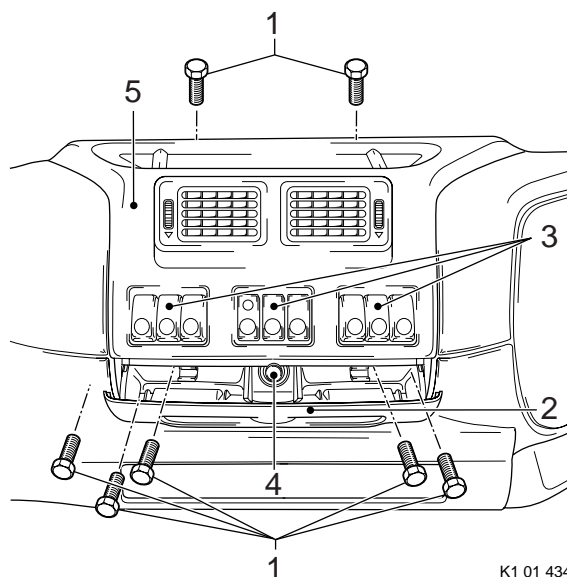

K1 01 434

Fitting the upper cover

1. Hook the cover into the cover panel. Fit the cover into the cover panel using the attachment bolts.

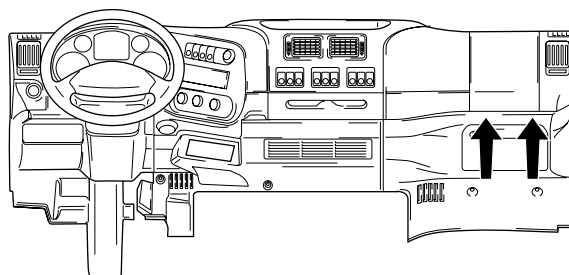

K1 01 433

Fitting the cover panel into the window frame

1. Fit the cover panel into the window frame using the attachment bolts (1).

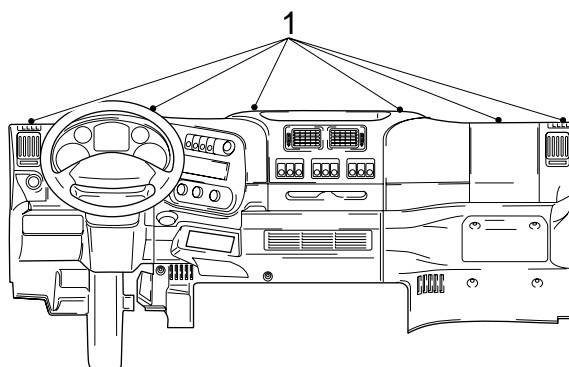

K1 01 432

1

LF45/55 series

INTERNAL CAB COMPONENTS

Removal and installation

Fitting the lower dashboard panel on driver's side

1. Fit the connector block to the rear of the dashboard panel using the attachment bolts.
2. Fit the connector of the headlamp height adjustment unit to the dashboard panel.
3. Fit the dashboard panel using the attachment bolts (1).

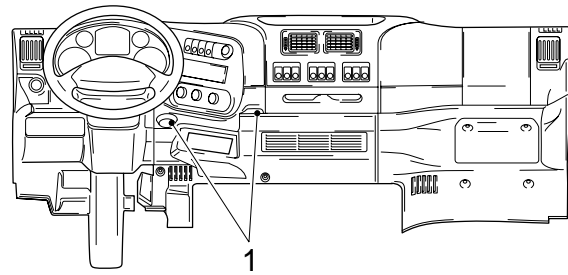

Installing the instrument panel

1. Fit the connector of the instrument panel (3).
2. Fit the instrument panel (3) to the dashboard panel using the attachment bolts.
3. Push the garnish moulding (2) back onto the dashboard panel using the mounting clips. Fix the garnish moulding (2) onto the dashboard panel using the attachment bolts (1).

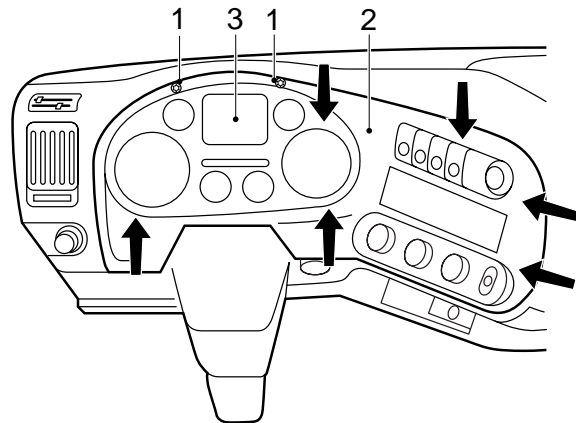

Fitting the engine tunnel dashboard panel

1. Remove the attachment bolts (1) and the panel plugs (2). Remove the engine tunnel cover panel.
2. Fit the connector of the 12V power supply to the rear of the engine tunnel dashboard panel.

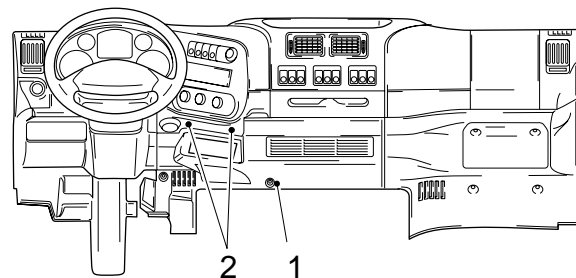

2

Fitting the lower dashboard panel on co-driver's side

1. Fit the lower dashboard panel on co-driver's side using the attachment bolts.

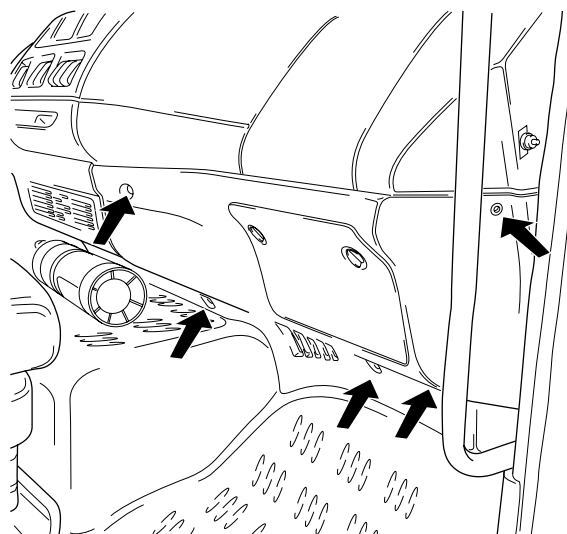

K1 01 428

Installing the steering column dashboard panel

1. Fit the steering column dashboard panel using the attachment bolts (1) and panel plug (2).

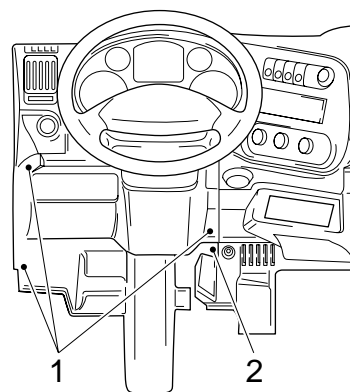

K1 01 427

4.3 REMOVAL AND INSTALLATION OF COMPLETE DASHBOARD

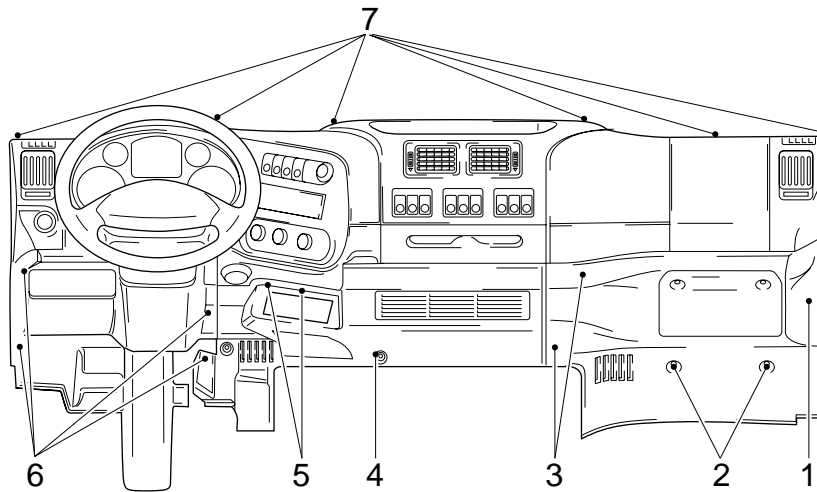

K1 01 437

Removing the dashboard

1. Disconnect the earth lead from the battery terminal.
2. Remove the attachment bolts and the panel plug (6). Remove the steering column cover panel.
3. Remove the attachment bolts (1), (2) and (3) and remove the cover panel on co-driver's side.
4. Remove the attachment bolts (4) and the panel plugs (5). Remove the engine tunnel cover panel. Remove the connector from the 12V power supply.
5. Remove the attachment bolts (7) and remove the upper cover panel.
6. Open the grille.

2

7. Remove the attachment bolt (1).
8. Remove the protective cover by pressing the retainer (2) aside.

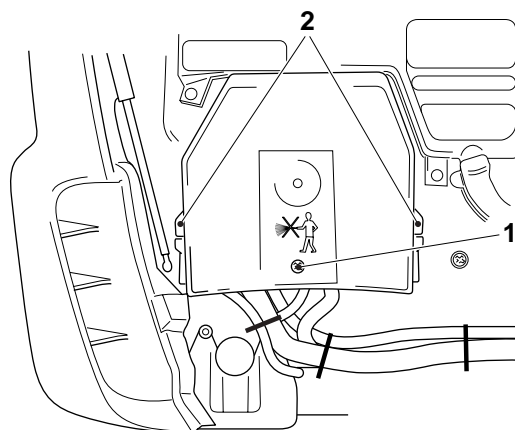

K1 00 988

9. Detach the connectors (1) from the connecting block.
10. Press the connecting block retainer (2) inside and push the complete connecting block inside.

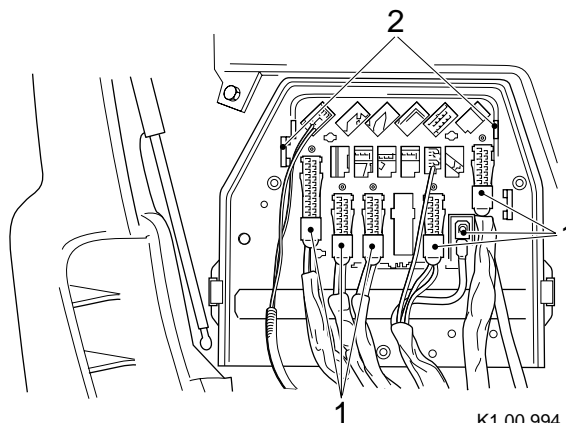

K1 00 994

11. Remove the cover plate (2) by releasing the retainer (1).

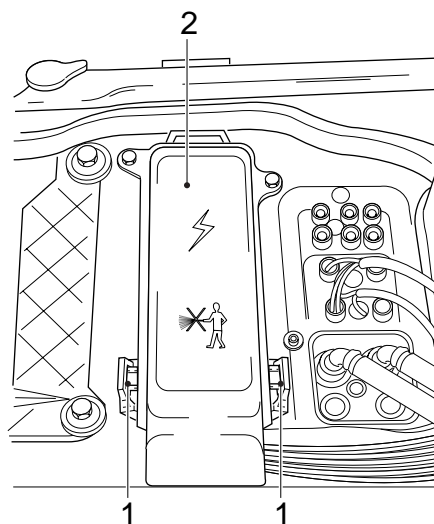

K100989

1

LF45/55 series

INTERNAL CAB COMPONENTS

Removal and installation

12. Remove the connectors (2).
13. Push the retainers (1) aside and the connector holder plate inside.

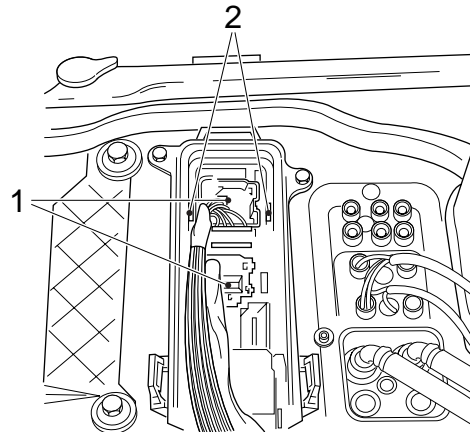

K1 00 990

14. Remove the attachment bolts (1) from the filter casing and remove the filter casing (2).

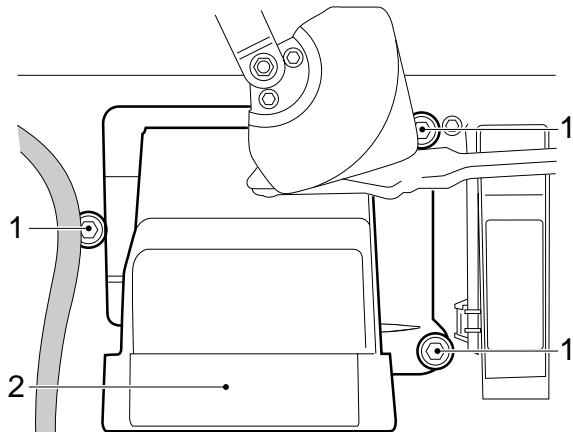

K1 01 194

15. Remove the attachment bolts (1).
16. Remove the heater hoses (2) and seal the heater tubes.
17. Remove the connectors to the left and right of the steering column.

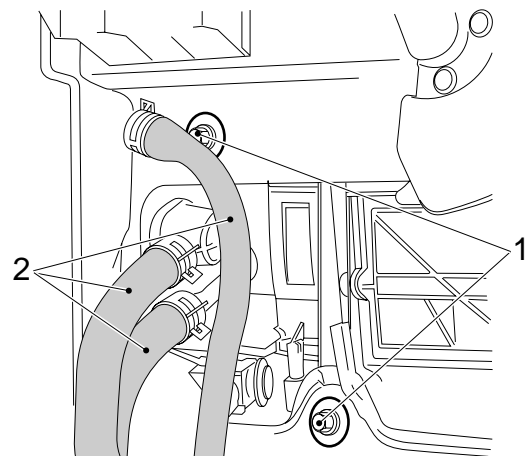

K1 01 175

2

18. Remove the connectors (2) and the earth connections (3).
19. Remove the attachment bolts on the underside of the dashboard, left and right.
20. Remove the attachment bolts (4) and (1).
21. Pull the cover plate in the A-pillar out of the retainer, remove the grip attachment bolt and remove the grip (5).
22. Remove the floor mats. Remove the diagnostic and ECAS connectors by taking the wiring apart and then removing the attachment bolts. Remove the connectors from the bracket.
23. Remove the floor plate above the wiring.
24. Remove the seat wiring.
25. Remove the attachment bolts from the window frame.
26. Remove the attachment bolts on the underside and remove the complete dashboard.

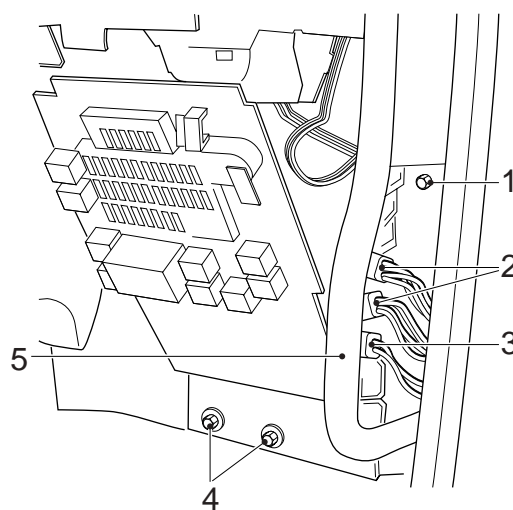

K1 00 986

Fitting the dashboard

1. Fit the dashboard and secure it in the window frame using a few attachment bolts.
2. Fit the seat wiring.
3. Install the floor plate above the wiring.
4. Fit the ECAS and diagnostic connectors to the bracket.
5. Fit the grip and the cover panel in the A-pillar.
6. Fit the connectors in the central box.
7. Remove the seals from the coolant hoses and attach the hoses.
8. Fit the connectors to the left and right of the steering column.

1

LF45/55 series

INTERNAL CAB COMPONENTS

Removal and installation

9. Insert the attachment bolts (1).
10. Fit the heater hoses (2).

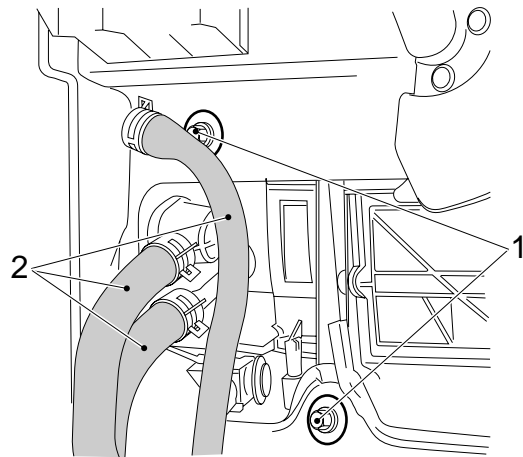

K1 01 175

11. Fit the filter casing (2). Secure the filter casing using the attachment bolts (1).

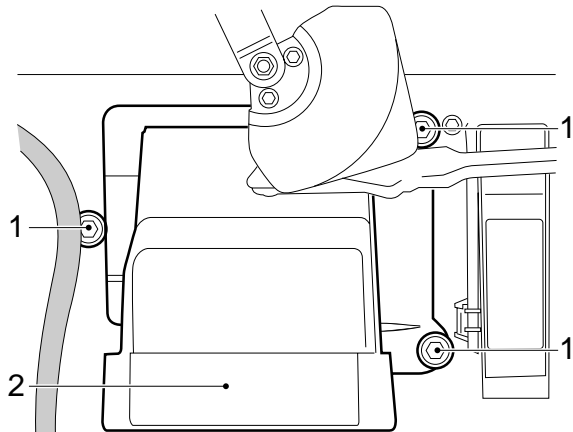

K1 01 194

12. Fit the plate for the connectors via the inside and press it into the retainers (2).
13. Fit the connectors (1).
14. Fit the cover plate.

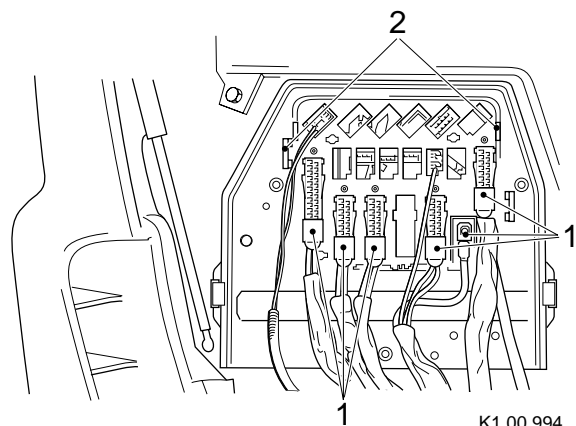

K1 00 994

2

INTERNAL CAB COMPONENTS

1

Removal and installation

LF45/55 series

15. Fit the connecting block via the inside and press it firmly into the retainers (2).
16. Fit the connectors (1) to the connecting block. Pay attention to the markings on the components.

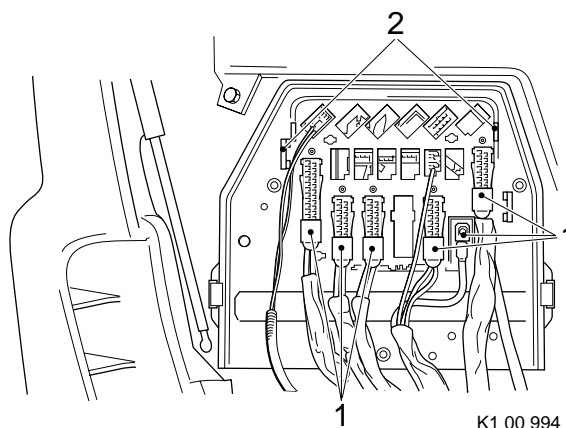

17. Fit the protective cover to the cab lead through and secure it using the attachment bolt (1).

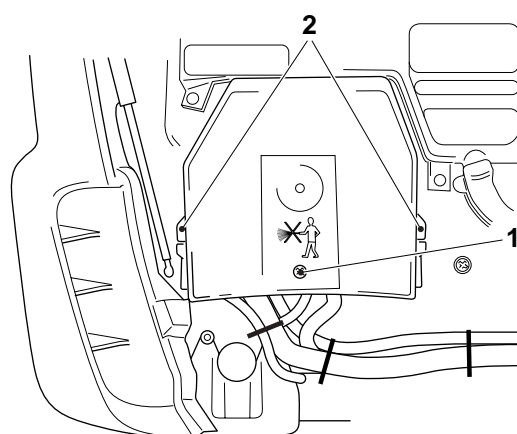

18. Close the grille.
19. Fit the attachment bolts under the dashboard to the left and right.
20. Secure the attachment bolts in the window frame.
21. Fit the dashboard panels on co-driver's side.
22. Fit the steering column dashboard panels.
23. Fit the connector of the 12V power supply to the engine tunnel cover panel.
24. Fit the cover panel to the engine tunnel.
25. Fit the earth lead to the battery terminal.

2

4.4 REMOVAL AND INSTALLATION, PNEUMATIC SWITCH/VALVE OF STEERING COLUMN ADJUSTMENT UNIT

Removing the pneumatic switch/valve of the steering column adjustment unit

1. Lay the floor mat aside.
2. Remove the attachment bolts (1) from the switch/valve.

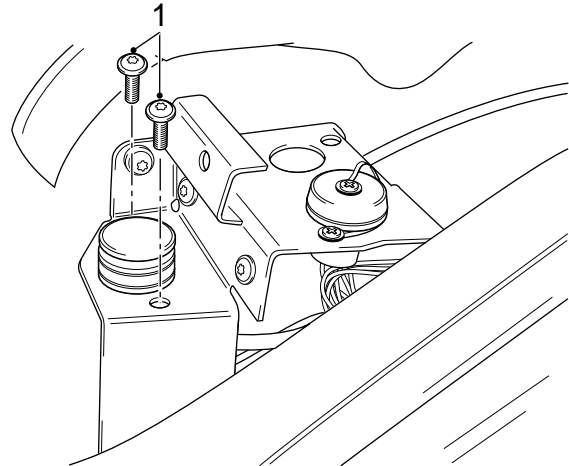

K1 01 120

3. Remove the bracket holding the switch/valve. Disconnect the air pipes (2) and remove the switch/valve.

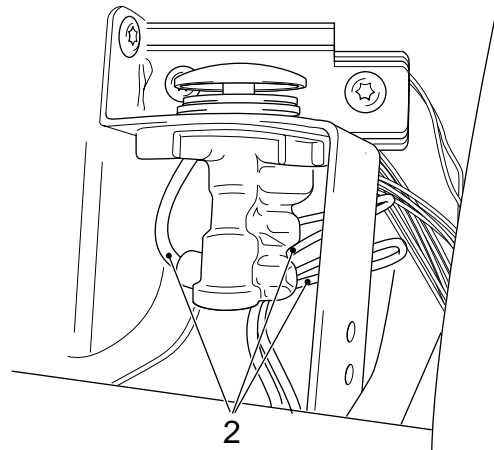

K1 01 121

Fitting the pneumatic switch/valve

1. Fit the air pipes (2) to the switch/valve.

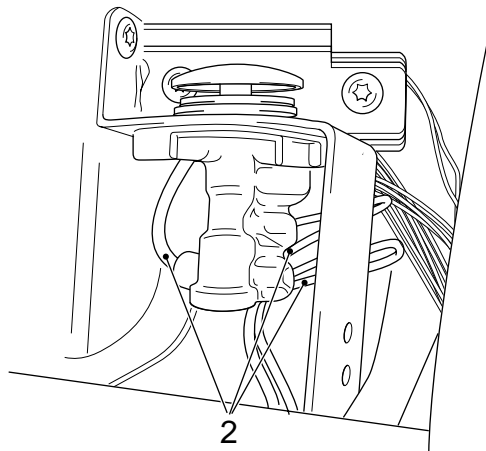

K1 01 121

2. Fit the switch/valve and secure them using the attachment bolts (1).

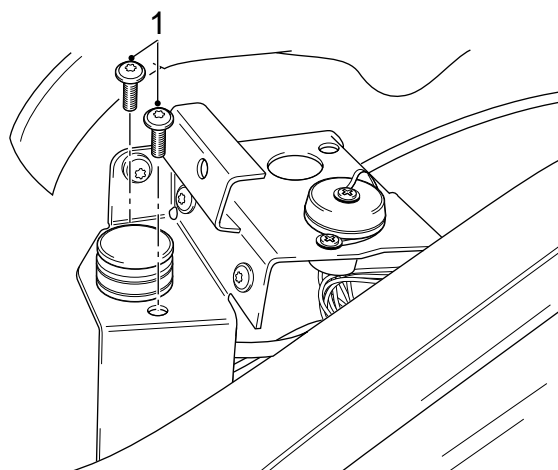

K1 01 120

3. Check the operation of the switch/valve, see chapter "Inspection and Adjustment".
4. Reposition the floor mat.

4.5 REMOVAL AND INSTALLATION, STEERING COLUMN

Note:

A steering wheel with an airbag can be recognised by the inscription "airbag" on the cover plate and the "Airbag" sticker on the windscreen.

Steering wheel model without airbag

Removing the steering column without airbag steering wheel

1. Place the steering box in the central position using the marks.

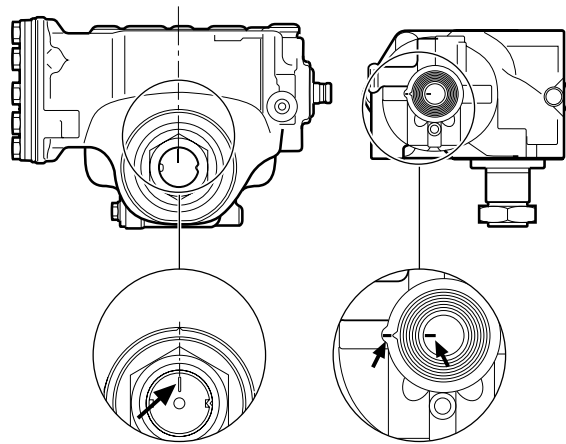

S7 00 623

2. Remove the steering column panel.
3. Depending on the work to be carried out, remove the floor dust cover or the cover panels beneath the steering wheel.
4. If applicable, remove the steering column adjustment air pipe.
5. Remove the connectors from the steering column.
6. Remove the attachment bolt of one universal joint of the steering shaft (depending on the operations to be performed; either the universal joint beneath the steering wheel or the universal joint on the steering box). Before loosening, mark the position of the universal joint versus the steering shaft.
7. Remove the attachment bolts. One of the attachment bolts is a security bolt. Remove this using a drift.
8. Remove the steering column.

Installing the steering column without airbag steering wheel

1. Check whether the steering box is still in the central position, using the markings.

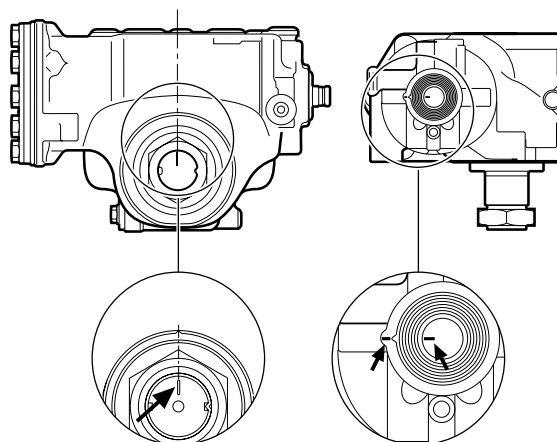

S7 00 623

2. Fit the steering column to the steering shaft and make sure that the marks between the universal joint and steering shaft align. Fit a new attachment bolt with nut in the universal joint. Tighten the attachment bolt to the specified torque, see main group "Technical data".
3. Place the steering column by tightening the top attachment bolts by hand.
4. Attach the air pipes to the connection block behind the dashboard. Check to see that the air pipes are not in contact with any moving parts.
5. Fit the steering column connectors.
6. Fit the lower attachment bolts and lock the steering column.
7. Fit the steering column panel and secure it with the attachment bolts and panel clips.

Steering wheel model with airbag

Observe the warnings and safety instructions applicable to working on an airbag system.

Removing the steering column with airbag steering wheel

1. Remove the airbag module.
2. Place the steering box in the central position using the marks.

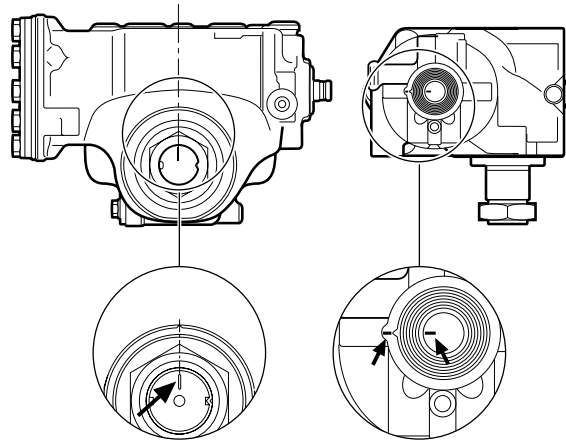

S7 00 623

3. Remove the panel under the tachograph.



There must at least be 5 minutes waiting time between disconnecting the battery leads and loosening the airbag connector. Non-observance of the 5 minutes waiting time may result in the airbag being activated when the connector is removed.

4. Remove the steering column panel.
5. Depending on the work to be carried out, remove the floor dust cover or the cover panels under the steering wheel.
6. If applicable, remove the steering column adjustment air pipe.
7. Remove the connectors from the steering column.

2

8. Remove the attachment bolt of one universal joint of the steering shaft (depending on the operations to be performed; either the universal joint under the steering wheel or the universal joint on the steering box). Before loosening, mark the position of the universal joint versus the steering shaft.
9. Lock the steering wheel to prevent it from turning, using, for example, adhesive tape



If the steering wheel is rotated more than 3 turns to the left or right from the centre position, the airbag contact unit will get damaged.

10. Remove the attachment bolts. One of the attachment bolts is a security bolt. Remove this using a drift.
11. Remove the steering column.

Installing the steering column with airbag steering wheel

1. Check that the steering box is still in the central position, using the marks.

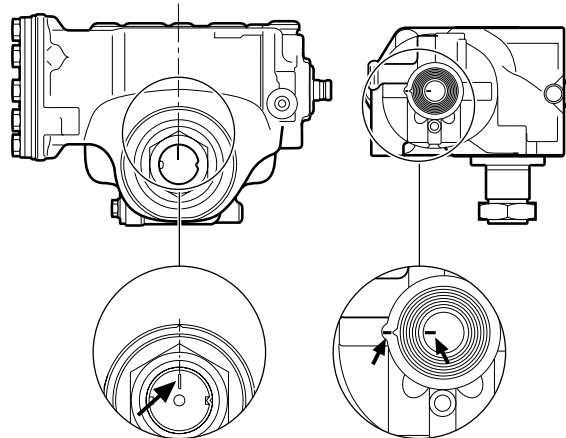

S7 00 623

2

2. Fit the steering column to the steering shaft and make sure that the marks between the universal joint and steering shaft align. Fit a new attachment bolt with nut in the universal joint. Tighten the attachment bolt to the specified torque, see main group "Technical data".
3. Place the steering column by tightening the top attachment bolts by hand.
4. Attach the air pipes to the connection block behind the dashboard. Check to see that the air pipes are not in contact with any moving parts.
5. Fit the steering column connectors.
6. Fit the lower attachment bolts and lock the steering column.
7. Fit the steering column panel and secure it with the attachment bolts and panel clips.
8. Fit the panel.
9. Fit the airbag module.

4.6 REMOVAL AND INSTALLATION, STEERING WHEEL

Note:

A steering wheel with an airbag can be recognised by the inscription "Airbag" on the cover plate and the "Airbag" sticker on the windscreen.

Steering wheel without airbag

Removing the steering wheel without airbag

1. Check that the steering wheel is not equipped with an airbag.
2. Place the steering box in the central position using the marks.

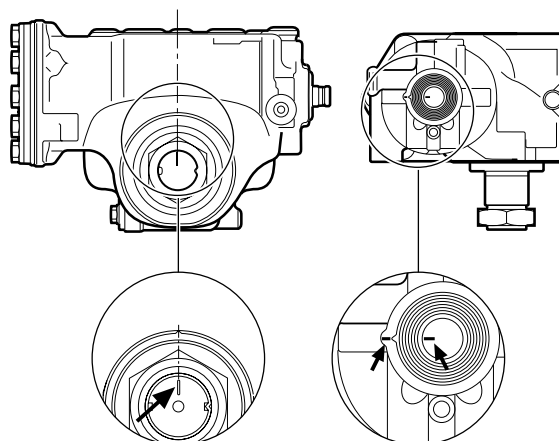

S7 00 623

3. Remove the cover plate from the steering wheel.
4. Remove the steering wheel bolt (2).
5. Make marks (A and B) on the steering wheel (1) and the steering shaft (3).

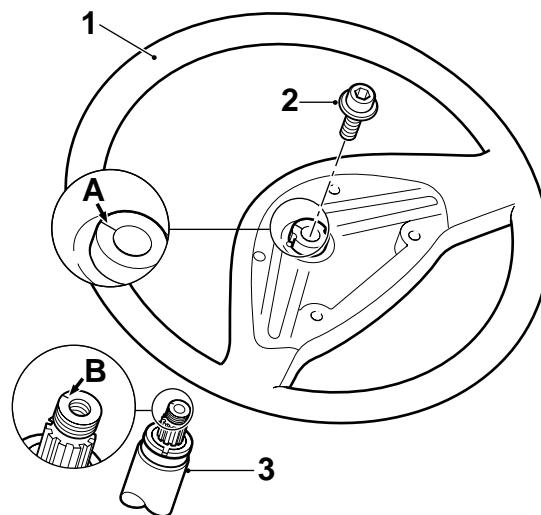

K1 01 321

1

LF45/55 series

INTERNAL CAB COMPONENTS

Removal and installation

6. Fit the steering wheel puller (DAF no. 1451995) on the steering wheel.
7. Make sure the bottom of the spindle (1) is level with the bottom of the attachment bolts (2).
8. Turn the spindle (1) approximately 10 mm into the steering shaft.
9. Turn both attachment bolts (2) approximately 10 mm into the steering wheel.
10. Evenly tighten both attachment bolts (2) alternately until the steering wheel comes loose.

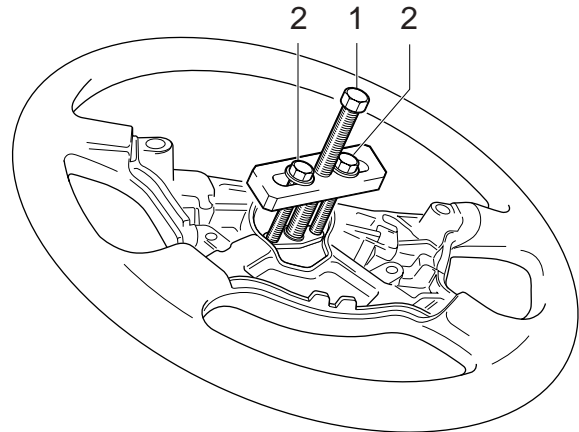

K1 01 324

Fitting the steering wheel without airbag

1. Fit the steering wheel (1) on the steering shaft (3) so that the markings on the steering wheel and steering shaft (A and B) "align". Ensure that the ridges on the rear of the steering wheel fall into the recesses. Check that the steering box is still in the central position, if a new steering wheel is fitted.
2. Fit the attachment bolt (2). Tighten the attachment bolt to the specified torque, see main group "Technical data".
3. Fit the cover plate on the steering wheel.

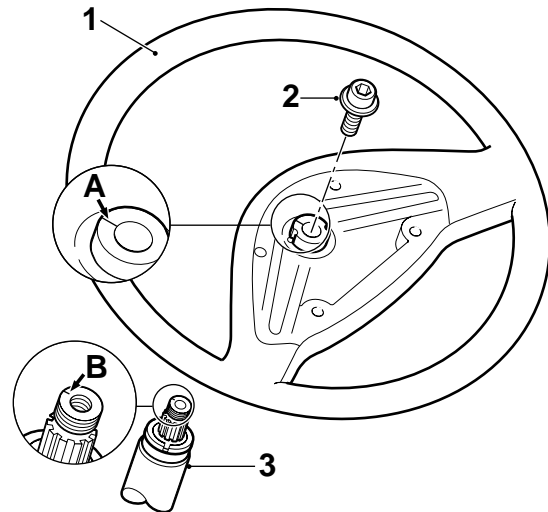

K1 01 321

2

Steering wheel with airbag



Observe the warnings and safety instructions applicable to working on an airbag system.

Removing the steering wheel with airbag

1. Disconnect the earth leads from the battery.
2. Place the steering box in the central position using the marks.

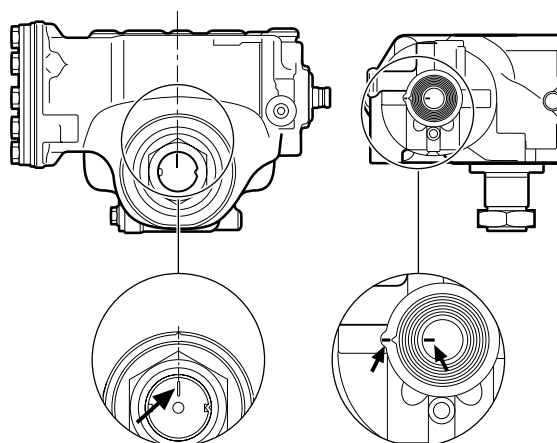

S7 00 623

3. Remove the covers from the steering column.



There must at least be 5 minutes waiting time between disconnecting the battery leads and loosening the airbag connector. Non-observance of the 5 minutes waiting time may result in the airbag being activated when the connector is removed.

4. Remove the steering wheel bolt (2).
5. Make marks (A and B) on the steering wheel (1) and the steering shaft (3).

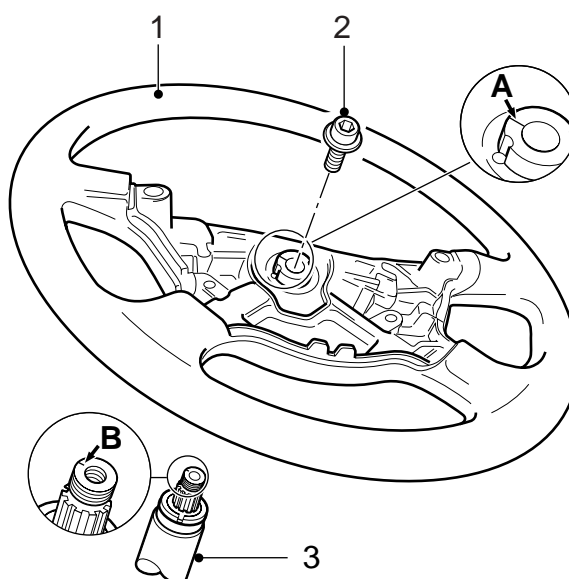

K1 01 505

6. Fit the steering wheel puller (DAF no. 1451995) on the steering wheel.
7. Make sure the bottom of the spindle (1) is level with the bottom of the attachment bolts (2).
8. Turn the spindle (1) approximately 10 mm into the steering shaft.
9. Turn both attachment bolts (2) approximately 10 mm into the steering wheel.
10. Evenly tighten both attachment bolts (2) alternately until the steering wheel comes loose.

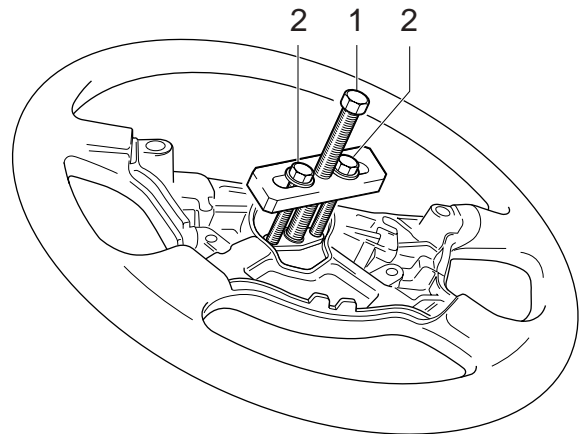

K1 01 324

Fitting the steering wheel with airbag

1. Fit the steering wheel (1) on the steering shaft (3) so that the markings on the steering wheel and steering shaft (A and B) "align". Ensure that the ridges on the rear of the steering wheel fall into the recesses. Check that the steering box is still in the central position, if a new steering wheel is fitted.
2. Fit the attachment bolt (2). Tighten the attachment bolt to the specified torque, see main group "Technical data".
3. Fit the airbag module.
4. Fit the steering column covers.

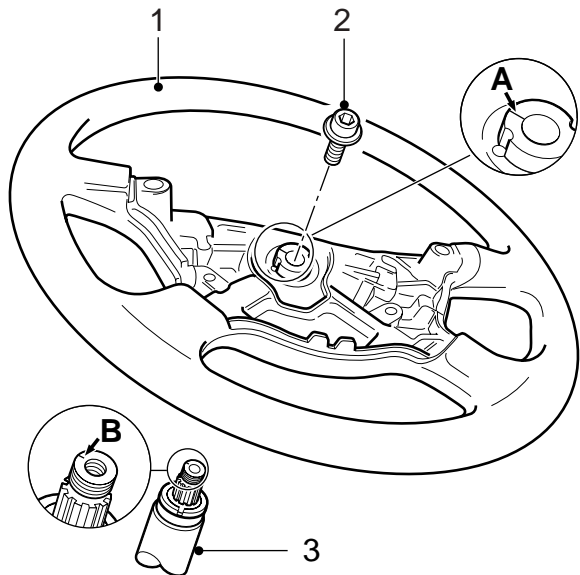

K1 01 505

4.7 REMOVAL AND INSTALLATION, DOOR PANEL

Removing the door panel

1. Loosen the cap from the grip by pushing a screwdriver into the recesses (1).
2. Remove the cap from the grip.
3. Remove the caps (2) at the bottom of the door.
4. Remove the attachment bolts from the door.

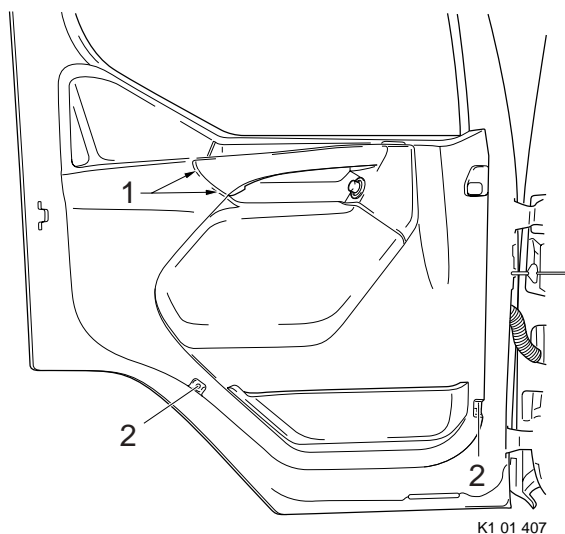

5. Remove the attachment bolts (1) from the grip.
6. Disconnect the electric window and mirror connectors at the inside of the grip.
7. Push the grip down as far as it will go.
8. Push the control cable clip (2) out of the grip.
9. Remove the control cable from the door knob. Put the grip aside.

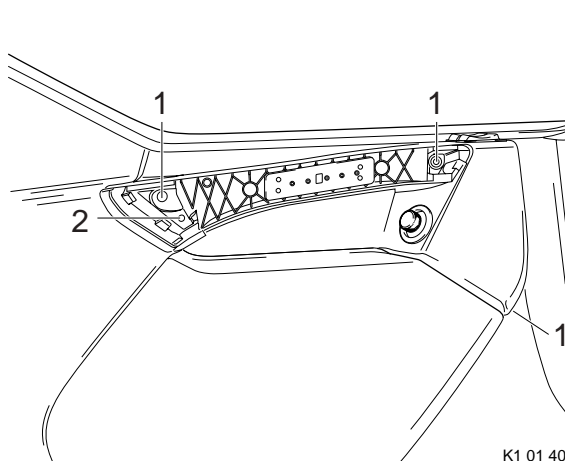

10. Pull the door panel out of the mounting clips in the door, starting at the bottom.
11. Lift the door panel out of the window frame.

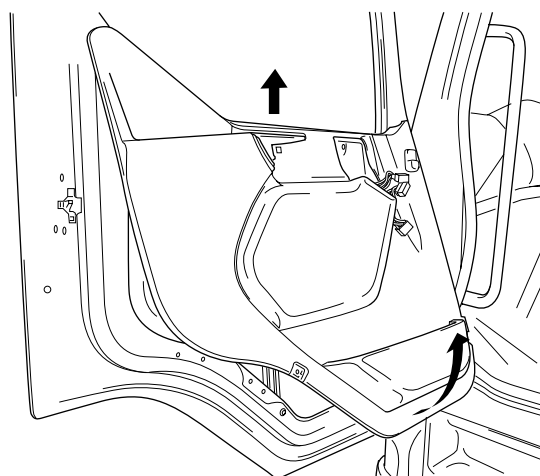

Installing the door panel

1. Fit the door panel into the upper part of the window frame.
2. Press the door panel all around into the door using the mounting clips.
3. Secure the lower part of the door panel using the attachment bolts and fit the caps.
4. Position the grip on the door panel.
5. Fit the nipple of the control cable in the door catch of the grip (A). Fit the coupler into the grip (B).
6. Secure the control cable coupler into the grip (C) using the mounting clip.

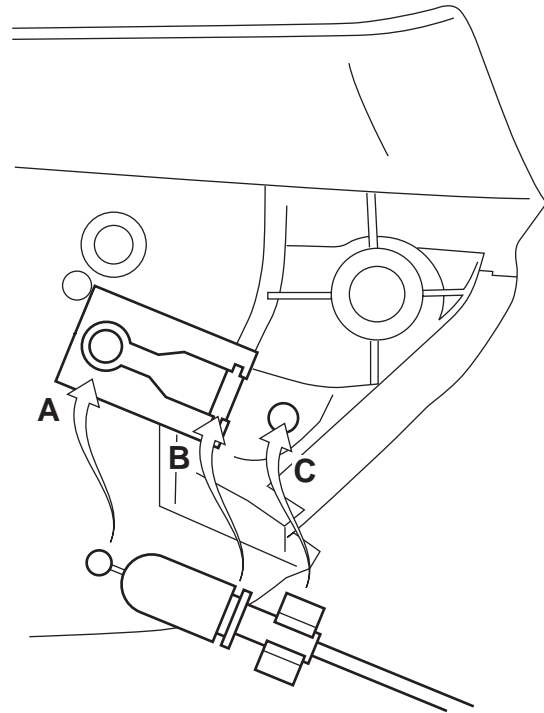

K1 01 441

7. Fit the automatic mirror and window connectors into the grip.
8. Fix the grip to the door using the attachment bolts (1).
9. Fit the grip cap.

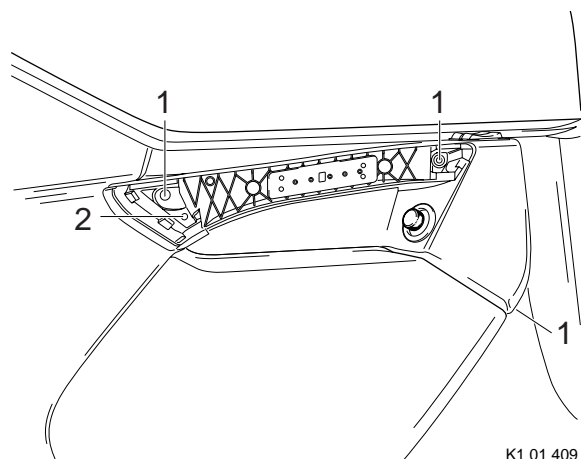

K1 01 409

4.8 REMOVAL AND INSTALLATION, MANUALLY OPERATED WINDOW MECHANISM

Removing the manually operated window mechanism

1. Remove the door panel.
2. Remove the door screen.
3. Support the door window using a block (1) and remove the attachment bolts (4). Remove the window on the underside so that it is no longer locked in position.
4. Remove the attachment bolts (3) and the attachment nut (2) from the window mechanism.
5. Tilt the window mechanism (5) and remove it through the bottom of the door.

Installing manually operated window mechanism

1. Fit the window mechanism (5) through the bottom of the door.
2. Remove the block (1) and hook up the door window in the window mechanism. Secure the door window with the attachment bolts (4).
3. Secure the window mechanism with the attachment bolts (3) and nut.
4. Close the door window until nearly shut. Check that the top edge of the window is parallel with the window frame. Loosen the attachment bolts (4), if necessary. Move the window to the correct position and re-tighten the attachment bolts.
5. Fit the door screen.
6. Install the door panel.

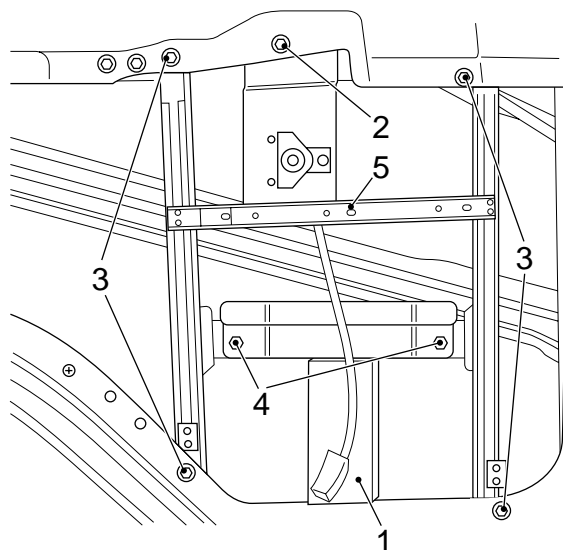

K1 00 977

4.9 REMOVAL AND INSTALLATION, ELECTRICALLY OPERATED WINDOW MECHANISM

Removing the electrically operated window mechanism

1. Remove the door panel.
2. Remove the door screen.
3. Lower the window, remove the attachment bolts (2) and slide the window up. Support the window with a block (1).
4. Disconnect the connector (4) from the electric motor.
5. Remove the attachment bolts (2) and nuts (3) and remove the window mechanism from the door through the opening.

Installing the electrically operated window mechanism

1. Fit the window mechanism in the door and fit the attachment bolts (2) and attachment nuts (3).
2. Connect the electric motor connector (4).
3. Lower the window and attach the window mechanism to the door using the attachment bolts (2).
4. Operate the window switch. Close the window until nearly shut. Check that the top edge of the window is parallel with the window frame. Loosen the attachment bolts (2), if necessary. Move the window to the correct position and re-tighten the attachment bolts.
5. Fit the door screen.
6. Install the door panel.

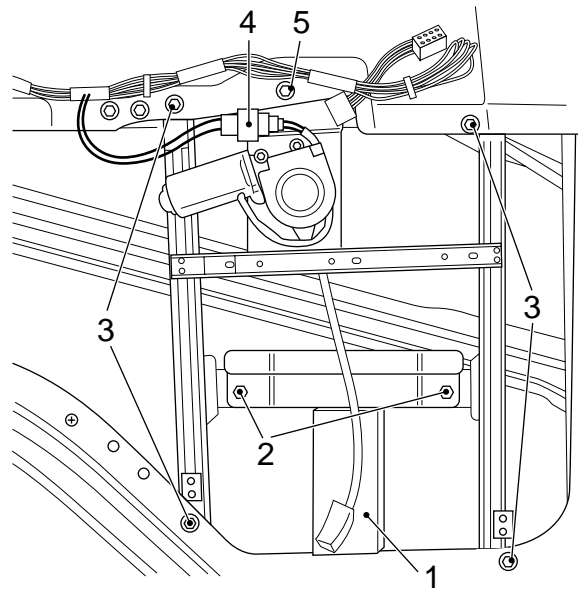

K1 00 974

4.10 REMOVAL AND INSTALLATION, ROOF CONSOLE**Removing the roof console**

1. Remove the top lighting attachment bolts from the outside of the vehicle and put the lighting aside.
2. Remove the top lighting connector.
3. Remove the wiring covers in the roof console.
4. Remove the interior lighting connector.
5. Remove the loudspeaker and its connector.
6. Remove the wiring harness from the roof console.
7. Remove the attachment bolts (2) from the roof console in the window frame.
8. Remove the covers (1) at the front and remove the attachments bolts behind these covers.
9. Remove the roof console.

Installing the roof console

1. Put the roof console in place and position it using a few attachment bolts.
2. Place the attachment bolts at the front of the roof console and tighten them.
3. Fit the connectors for the interior lighting, loudspeaker and top lighting.
4. Fit the attachment bolts (2) in the window frame.
5. Secure the top lighting with the attachment bolts.
6. Fit the covers (1).

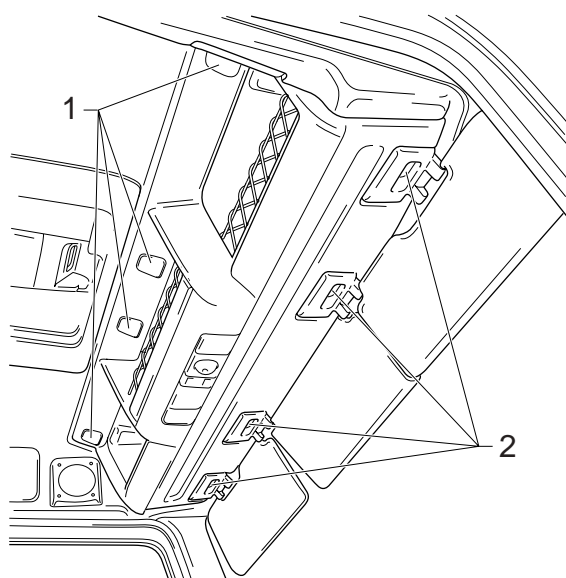

K1 01 123

4.11 REMOVAL AND INSTALLATION, INTERIOR LIGHTING

Removing the interior ceiling lighting

1. Put a screwdriver between the glass cover (1) and the holder (2).
2. Remove the glass cover (1).

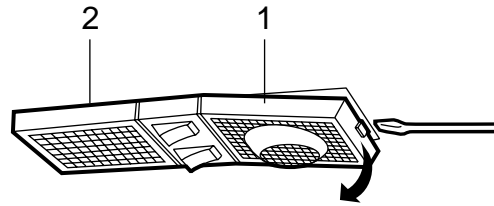

K1 01 169

3. Bend the lock levers (B) inwards.
4. Unplug the connectors and remove the lamp holder.

Fitting the interior ceiling lighting

1. Bend the lock levers (B) outwards.
2. Hook up the connectors and fit the lamp holder (2).
3. Fit the glass cover (1).

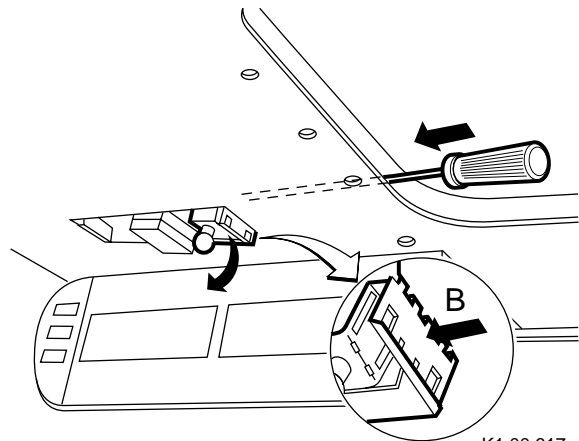

K1 00 617

4.12 REMOVAL AND INSTALLATION, IGNITION LOCK

Removing the ignition lock

1. Remove the covers around the steering column under the steering wheel.
2. Disconnect the connectors (behind the dashboard).
3. Drill off the head of the security bolt, use a bit with the same diameter as the hole where the head falls and remove the ignition lock.

Installing the ignition lock

1. Install the ignition lock.
2. Tighten the security bolts with such a tightening torque that the heads break off.
3. Fit the covers around the steering column.

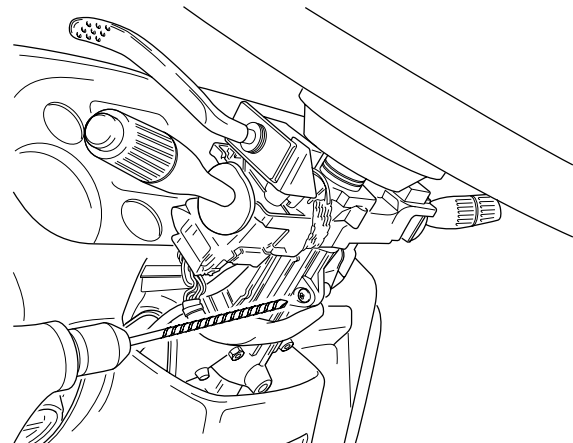

K1 01 134

4.13 REMOVAL AND INSTALLATION, COMPLETE DOOR LOCK MECHANISM

Removing the complete door lock mechanism

1. Close the window.
2. Remove the door panel.

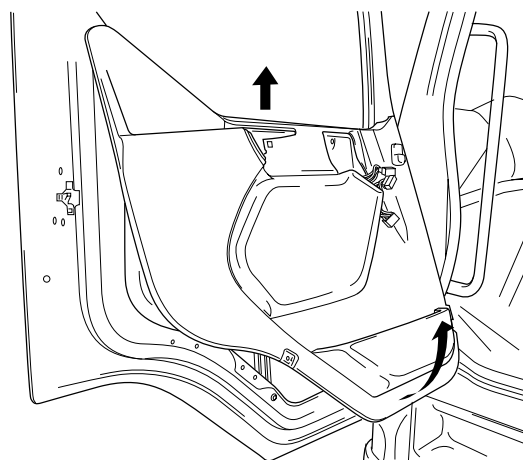

K1 01 408

3. Gently remove the plastic screen (1) from the door.
4. Remove the attachment bolts (6) from the closing mechanism.
5. Remove the attachment bolts (5) from the door lock mechanism.
6. Remove the plug (4) from the central door locking mechanism.
7. Remove the clamping strips (3) holding in place the main wiring harness (2) and the wiring harness of the central door locking mechanism.
8. Lay the main wiring harness (2) aside
9. Remove the control rod by loosening the control rod locking (1) through tilting and unhooking the control rod from the locking.
10. Unhook the door lock mechanism from the door and allow it to be lowered together with the door locking
11. Remove the attachment bolts (3) from the door lock mechanism.

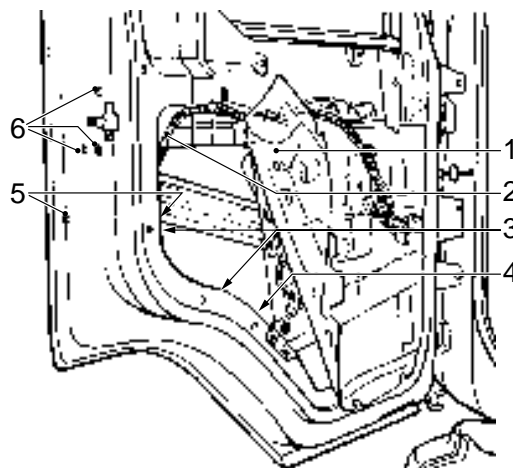

K1 01 439

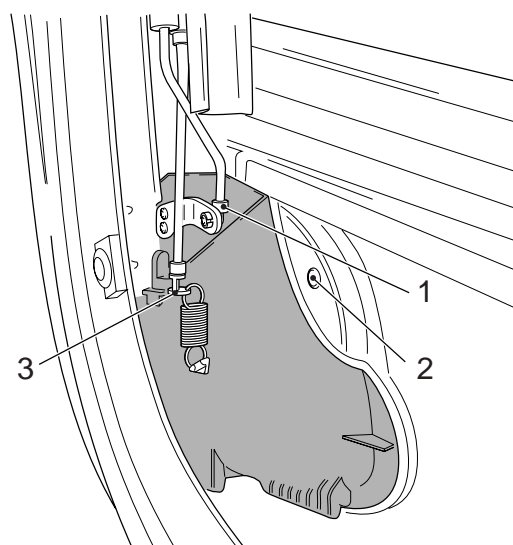

K1 01 124

12. Remove the complete door lock mechanism from the outside.
13. Remove the closing mechanism together with the motor of the central door locking from the inside of the door.

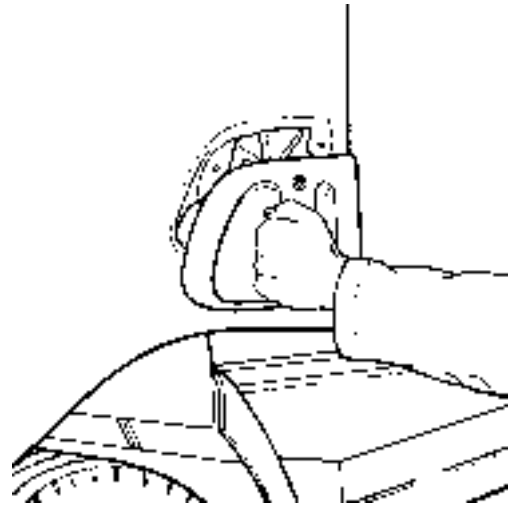

K1 01 171

Fitting the complete door lock mechanism

1. Fit the closing mechanism in the door.
2. Hook the control cable (3) in the door lock mechanism.
3. Position the door lock mechanism in the door.
4. Hook the control rod in the locking (1) of the operating lever. Lock the control rod by clicking the locking (1) in place over the control rod.

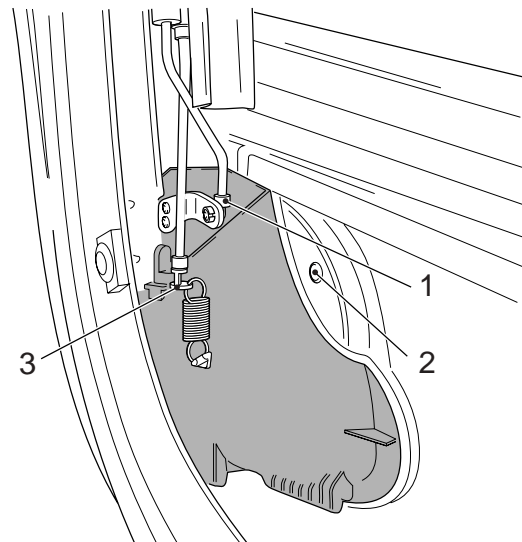

K1 01 124

5. Fit the attachment bolts (6) of the closing mechanism.
6. Fit the attachment bolts (5) of the door lock mechanism.
7. Fit the plug (4).
8. Secure the main wiring harness (2), the wiring harness of the central door locking and the plug (4) to the threaded ends at the inside of the door, using clamping strips.
9. Fit the door screen (1).
10. Install the door panel.

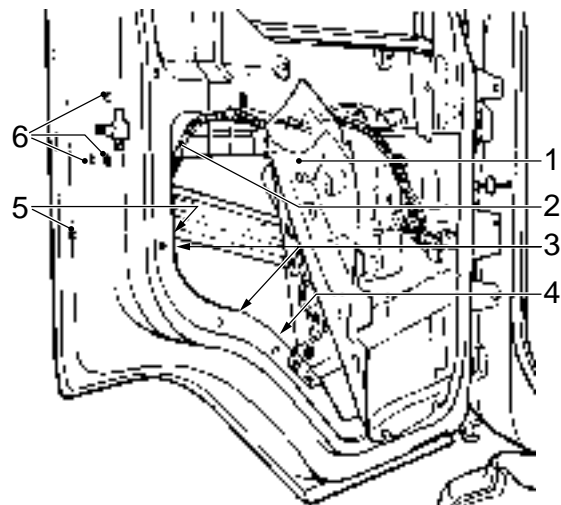

K1 01 439

4.14 REMOVAL AND INSTALLATION, DOOR LOCK CYLINDER**Removing the door lock cylinder**

1. Remove the complete door lock mechanism.
2. Remove the circlip (3).
3. Detach the operating lever (4).
4. Loosen the locking spring (1) and remove the door lock cylinder (2).

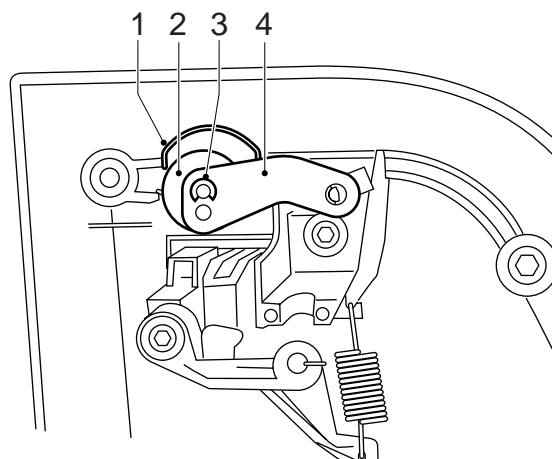

K1 01 440

Fitting the door lock cylinder

1. Fit the door lock cylinder (2). Fit the locking spring (1).
2. Fit the operating lever (4).
3. Fit the locking ring (3).
4. Fit the complete door lock mechanism.

4.15 REMOVAL AND INSTALLATION, ENGINE BRAKE SWITCH**Removing the engine brake switch**

1. Remove the covers from the steering column.
2. Remove the engine brake switch connector from the connector holder next to the steering column.
3. Remove the attachment bolts (1) from the engine brake switch.
4. Remove the engine brake switch (2).

Installing the engine brake switch

1. Fit the engine brake switch (2).
2. Secure the attachment bolts (1).
3. Fit the connector.
4. Fit the steering column covers.

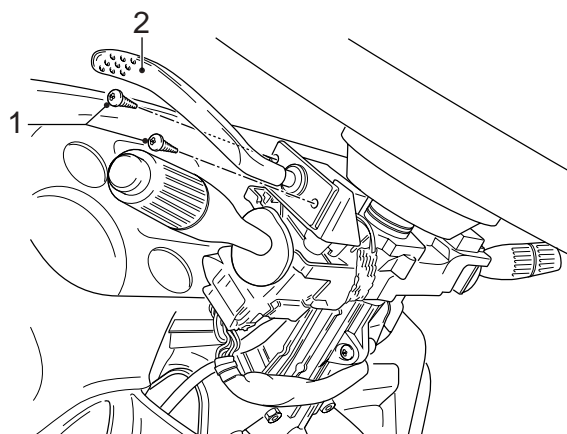

K1 01 164

4.16 REMOVAL AND INSTALLATION, REAR WALL LINING

Removing the rear wall lining

Note:

When working on the upholstery make sure hands are clean or wear gloves.

1. Remove the panel clips on the rear wall of the cab.
2. If applicable, remove the thermostat and clock from their casing using a small screwdriver.
3. Remove the rear wall supports.
4. Remove the (entrance) grip.
5. Remove the rear wall lining. Pay attention to the connectors for the cab heater sensor and lighting.

Installing the rear wall lining

1. Fit the rear wall using the panel clips. Pay attention to the connectors for the cab heater sensor and lighting.
2. Fit the (entrance) grip.
3. Fit the supports to the rear wall.
4. Fit the thermostat and clock if applicable.

4.17 REMOVAL AND INSTALLATION, ROOF LINING

Removing the roof lining

1. Remove the dashboard.
2. Remove the steering wheel.

Note:

When working on the upholstery make sure hands are clean or wear gloves.

3. Remove the roof console.
4. Remove the rear window cover, if applicable.
5. Remove the panel clips from the roof lining.
6. Remove the cover panels from the A-pillar.
7. Partially remove the door rubbers.
8. Remove the entrance grips if the vehicle has a sleeper cab.
9. Remove the connectors from the roof console lighting.

Installing the roof lining

1. Fit the roof lining from the co-driver's side.
2. Fit the lighting connectors. Fit the roof console.
3. Fit the entrance grips.
4. Fit the door rubbers.
5. Fit the panel clips.
6. Fit the rear window cover.
7. Fit the cover panels in the A-pillar.
8. Fit the steering wheel.
9. Fit the dashboard.

4.18 REMOVAL AND INSTALLATION, SIDE WALL LINING

Removing the side wall lining

Note:

When working on the upholstery make sure hands are clean or wear gloves.

1. Remove the caps from the door pillar.
2. Remove the steel plates that are fixed to the rear wall.
3. If the vehicle has a sleeper cab, the storage trays under the bed need to be removed.
4. Remove the panel clips and the side wall lining.

Installing the side wall lining

1. Fit the side wall lining using the panel clips.
2. If applicable, fit the storage trays.
3. Fit the steel panels to the side walls.
4. Fit the covers in the door pillar.

4.19 REMOVAL AND INSTALLATION, STORAGE TRAYS (SLEEPER CAB)

Removing the storage trays

1. Remove the wooden bed base.
2. Remove the rear wall panel and the side panels.
3. Remove the attachment bolts in the bottom of the storage trays.
4. Remove the storage tray.

Installing the storage trays

1. Put the storage trays in place.
2. Fit the attachment bolts in the bottom of the storage trays.
3. Fit the rear wall panels and the side panels.
4. Fit the wooden cover.

CONTENTS

	Page	Date
1. SAFETY INSTRUCTIONS	1-1	0210
2. GENERAL	2-1	0210
2.1 System description of heater, heater control	2-1	0210
3. REMOVAL AND INSTALLATION	3-1	0210
3.1 Removal and installation, interior filter	3-1	0210
3.2 Removal and installation, heater unit	3-2	0210
3.3 Removal and installation, heater control panel	3-8	0210
3.4 Removal and installation, heater motor	3-10	0210
3.5 Removal and installation, series resistor	3-13	0210
3.6 Removal and installation, heater radiator	3-15	0210

1. SAFETY INSTRUCTIONS



The air conditioning system may only be opened and filled by a specialist. Furthermore, many countries require official certification to carry out such activities.

2. GENERAL

2.1 SYSTEM DESCRIPTION OF HEATER, HEATER CONTROL

The heater is installed in the central console as a complete unit.
 The unit contains all control valves, control handles and switches needed for ventilation and heating.

There are two models:

- heating/ventilation system
- heating/ventilation system combined with air conditioning.

The control panel has three rotary knobs.

Knob 1

Five-position switch to control fan speed.

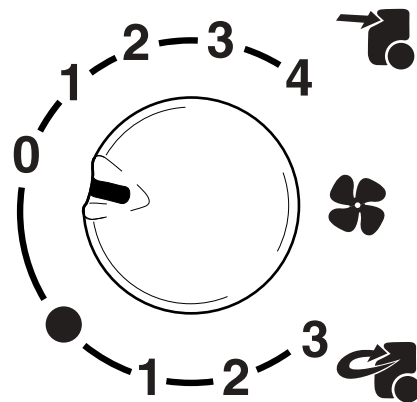

K1 01 197

Three-position switch to control fan speed with recirculation.

Knob 2

Air outlets in the cab.

- 0 = 0-position
- A = windscreen (defroster)
- B = windscreen and leg area
- C = leg area
- D = leg area and dashboard
- E = dashboard

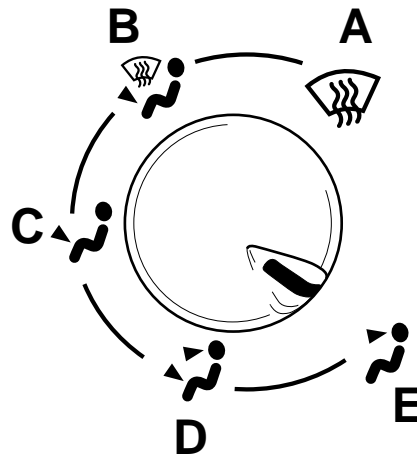

K1 01 195

Knob 3

Temperature control: offers a continuously variable supply of hot air from 0 to 100%.

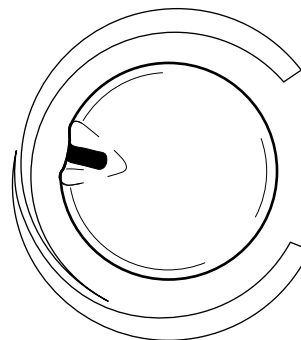

K1 01 196

3

Air distribution

Optimal air distribution in the cab can be achieved by means of knob 2 in combination with the rotating and adjustable vents on the central console and at the sides of the dashboard.

3. REMOVAL AND INSTALLATION

3.1 REMOVAL AND INSTALLATION, INTERIOR FILTER

Removing the interior filter

1. Open the cab grille.
2. Remove the attachment bolts (1) from the grille on the underside of the filter casing.
3. Open the grille (2) and remove the interior filter.

Installing the interior filter

1. Fit the interior filter, close the grille (2) and fit the attachment bolts (1).
2. Close the cab grille.

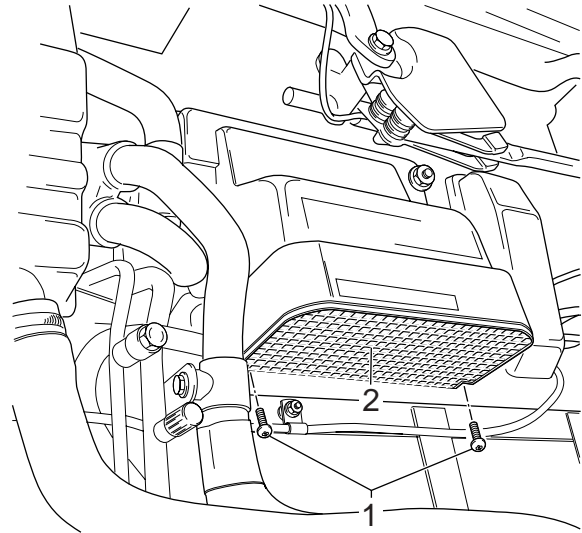

K1 01 147

3.2 REMOVAL AND INSTALLATION, HEATER UNIT

Removing the heater unit

1. Take the cover panel out of the window frame.
2. Remove all dashboard panels on the underside.
3. Remove the upper cover panel.
4. Remove the dashboard panels on the co-driver's side. Remove the garnish moulding around the instrument panel.
5. Remove the attachment bolts from the mounting plate at the front of the heater. Remove the mounting plate and the upper attachment bolts.
6. Take the heater control out of the radio panel and place it on the left-hand side of the heater.
7. Remove the heater unit connectors.
8. Remove the heater unit air ducts.

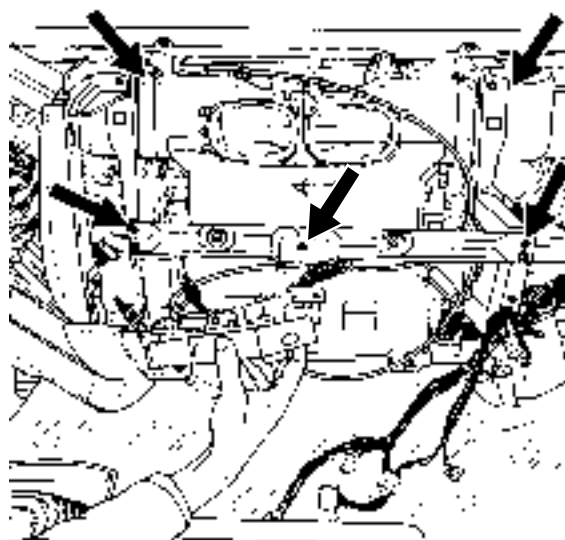

K1 00 950

9. Remove the upper attachment bolts from the heater unit.

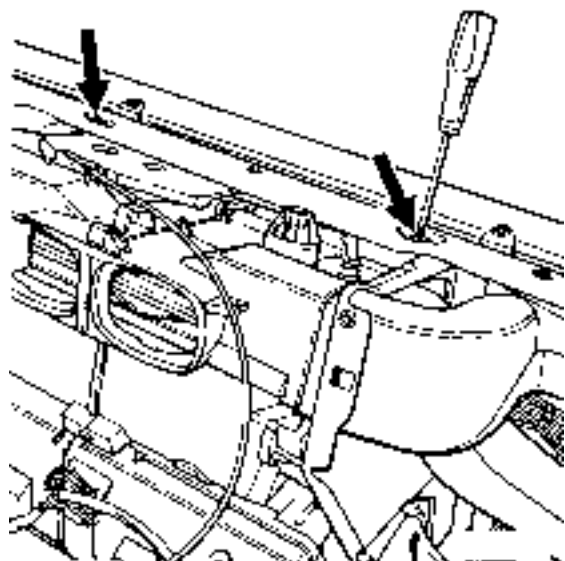

K1 00 951

10. Remove the interior filter casing attachment bolts (1) and remove the interior filter casing (2).

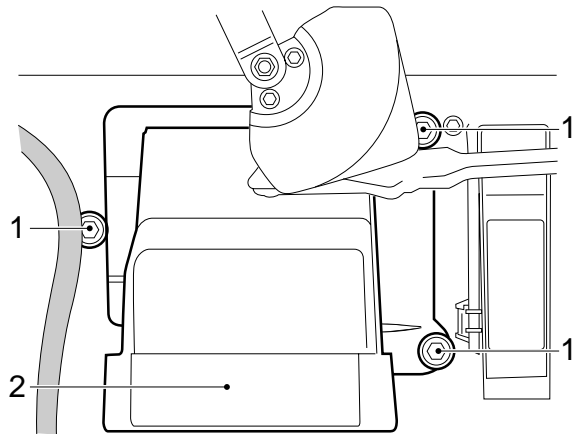

K1 01 194

11. Remove the attachment bolts from heater unit (1).
12. Partially drain the coolant.
13. Remove the heater hoses (2).

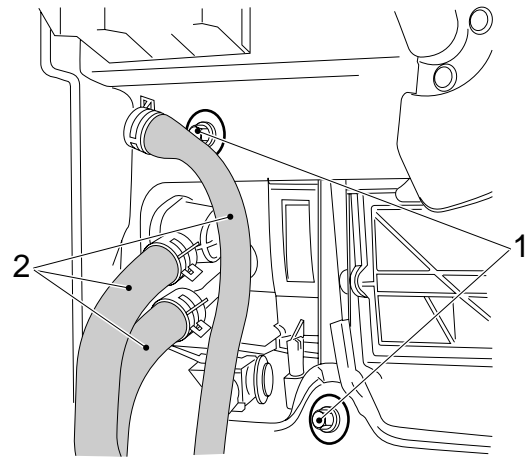

K1 01 175

14. Remove the cover (2) at the front by pressing the retainers (1) aside.

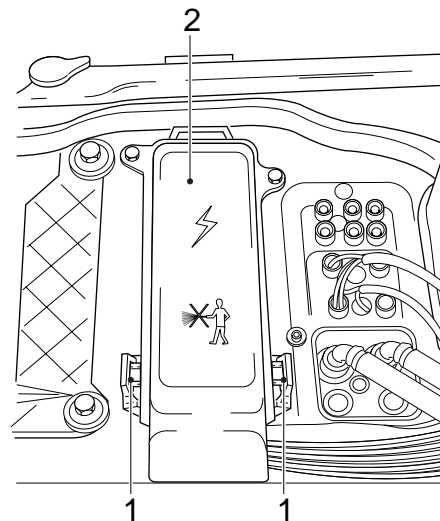

K100989

15. Remove the connectors (1), press the retainers (2) inwards and push the holder complete with connectors inside.

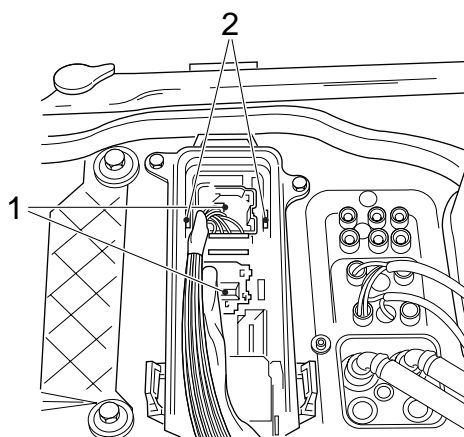

K1 00 990

Note:

If the vehicle has air conditioning fitted, any work on the air conditioning must be done by a qualified person.

16. If relevant, empty the air conditioning unit.
17. Remove the air conditioning pipes.
18. Remove the coolant hoses and seal the openings on the heater unit to prevent the coolant spilling out into the cab.
19. Remove the heater unit.

Installing the heater unit

1. Fit the heater unit. Push the holder for the connectors into the scuttle.
2. Fit the attachment bolts (1) and the heater hoses (2).

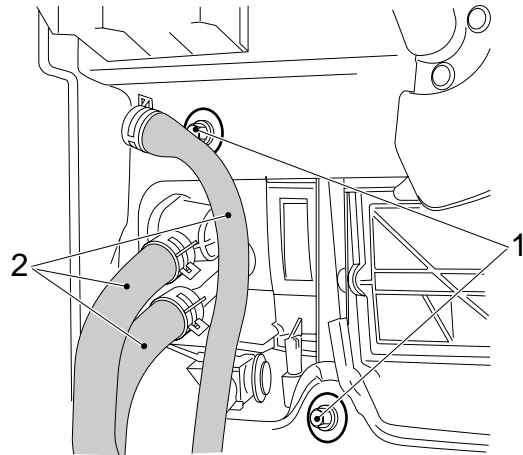

K1 01 175

3

3. Fit the interior filter casing (2). Secure it with the attachment bolts (1).

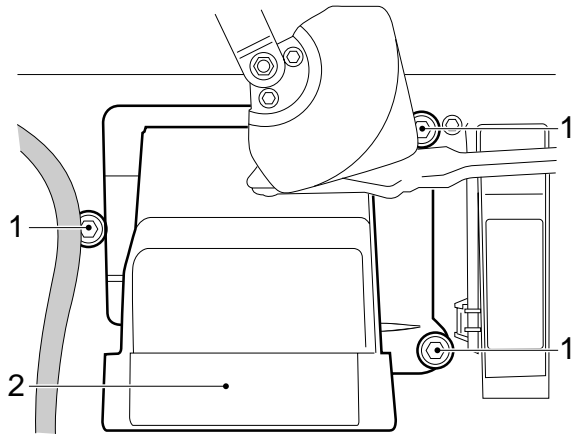

K1 01 194

4. Connect the air conditioning pipes.
5. Fit the heater unit air ducts.

6. Fit the connector holder via the inside. Push it into the retainers (2).
7. Fit the connectors (1).

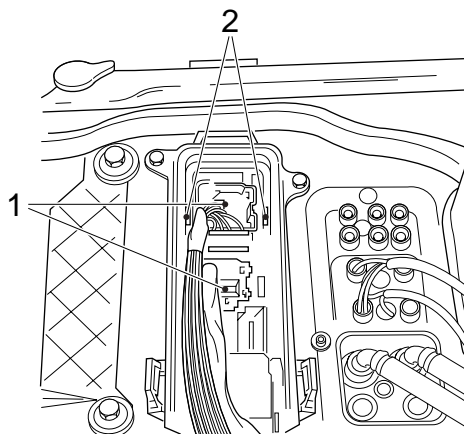

K1 00 990

8. Tighten the upper attachment bolts.

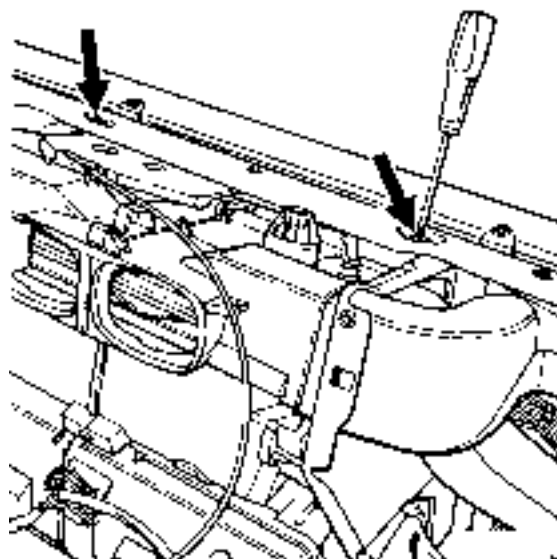

K1 00 951

9. Tighten the attachment bolts at the front.

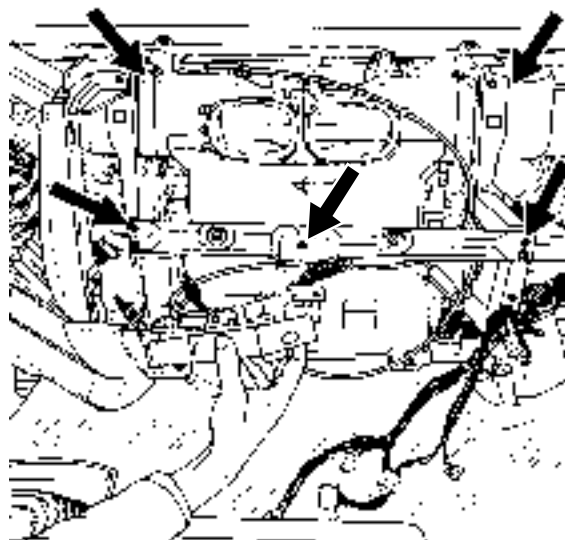

K1 00 950

10. Fit the heater control in the radio panel. Fit the garnish moulding around the instrument panel.
11. Re-install all removed dashboard panels.
12. Top up the cooling system.
13. Fill the air conditioning unit, if necessary.

3.3 REMOVAL AND INSTALLATION, HEATER CONTROL PANEL

Removing the heater control panel

1. Remove instrument panel cover panel.
2. Remove the control panel from the radio panel by pushing the right and left clips out.

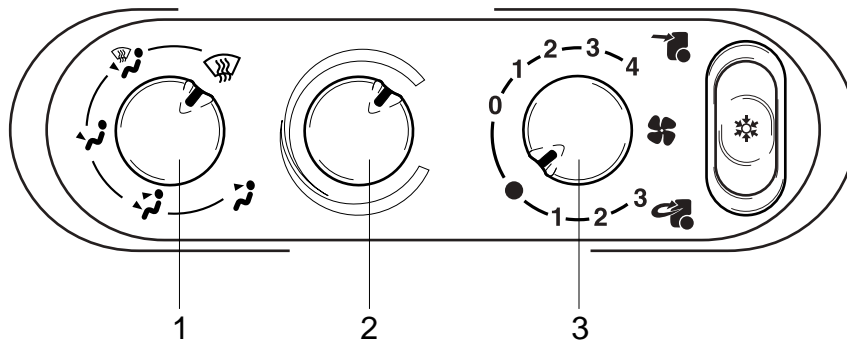

K1 01 211

3. Put the selection knob (1) in the windscreen demister position. Mark the position of the cable. Remove the clip and take the cable out of the control panel.
4. Set the temperature selection knob (2) to the hottest position. Mark the position of the cable. Remove the clip and take the cable out of the control panel.
5. Set the heater motor selection knob (3) to the "stop"-position. Mark the position of the cable. Remove the clip and take the cable out of the control panel.
6. If applicable, remove the connector from the air conditioning button.
7. Remove the control panel.

Installing the heater control panel

1. If applicable, fit the connector of the air conditioning button.
2. Fit the control cables and secure them with the clips at the appropriate markings. Make sure that the selection knobs are in the correct position.
3. Fit the control panel and push it into the retainer.
4. Fit the instrument panel cover panel and secure it with the attachment bolts.

3.4 REMOVAL AND INSTALLATION, HEATER MOTOR

Removing the heater motor

1. Remove the fire extinguisher, if applicable.
2. Remove the dashboard panel on the engine tunnel.
3. Remove the ashtray and the ashtray holder. Take out the cigarette lighter connector and remove the ashtray lighting.
4. Remove the connectors from the heater cover.
5. Remove the cover attachment bolts and put the cover aside.

3

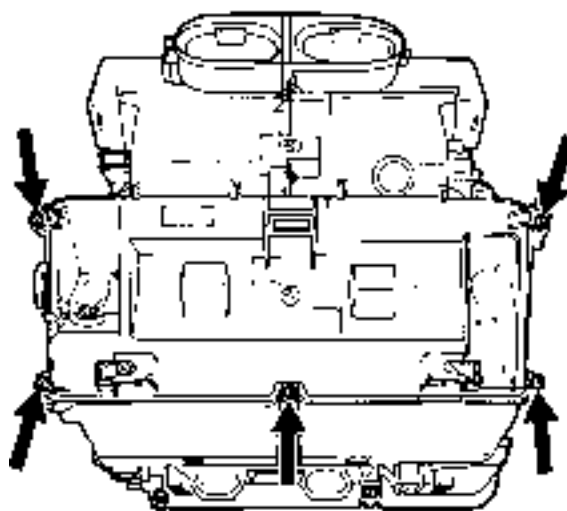

K1 00 953

6. Remove the connectors from the series resistor. If applicable, remove the connectors from the air conditioning thermostat.

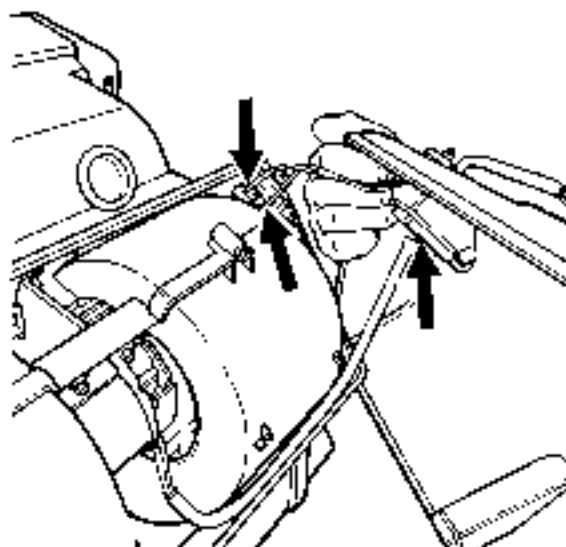

K1 00 954

7. Remove the cover.

8. Remove the heater motor attachment bolts.

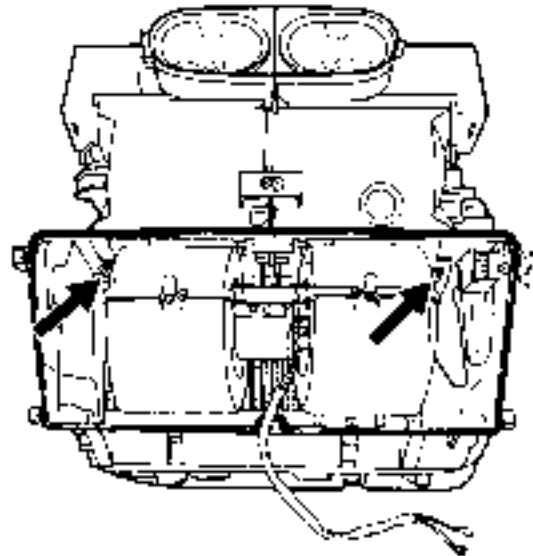

K1 00 955

9. Remove the heater motor.

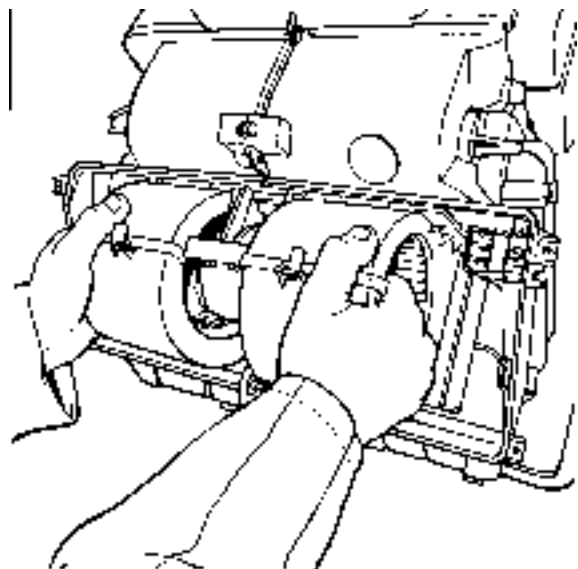

K1 00 956

Installing the heater motor

1. Install the heater motor and secure it with the attachment bolts.
2. Fit the connectors to the series resistor.

3. If applicable, fit the connectors to the air conditioning thermostat.
4. Fit the cover and secure it with the attachment screws.
5. Fit the connectors to the cover.
6. Fit the dashboard panel to the engine tunnel.

3.5 REMOVAL AND INSTALLATION, SERIES RESISTOR

Removing the series resistor.

1. Remove the fire extinguisher, if applicable.
2. Remove the dashboard panels on the underside.

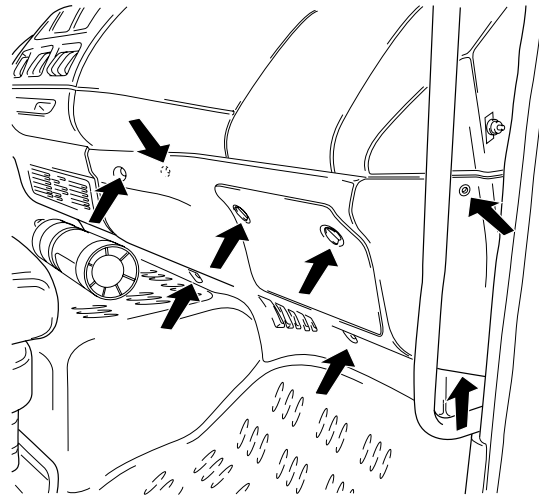

K1 01 133

3. Remove the attachment screws from the series resistor and remove the series resistor from the cover.

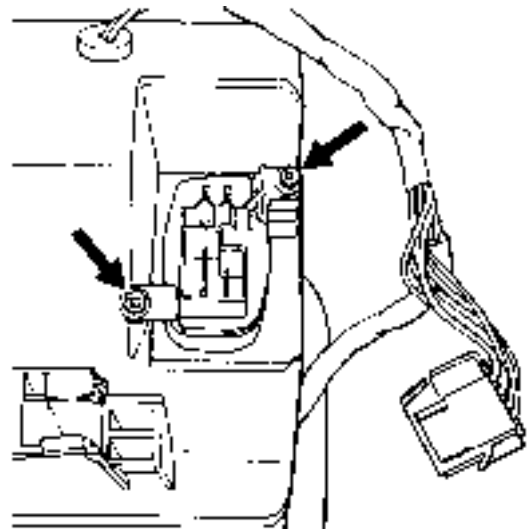

K1 00 957

4. Detach the connectors from the series resistor and remove the series resistor.

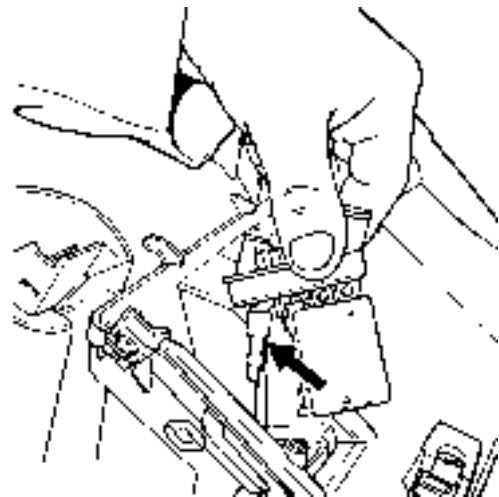

K1 00 958

Installing the series resistor

1. Fit the connector to the series resistor.

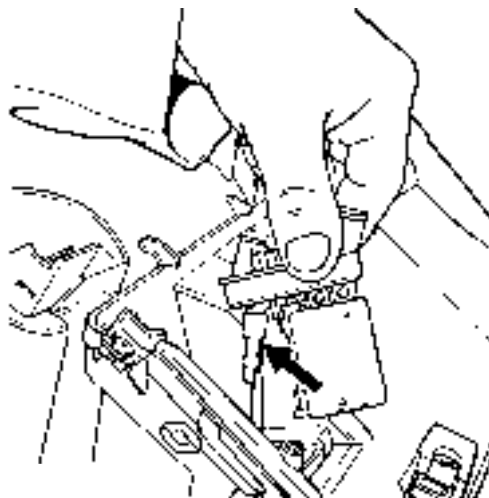

K1 00 958

2. Fit the resistor and secure it using the attachment screws.

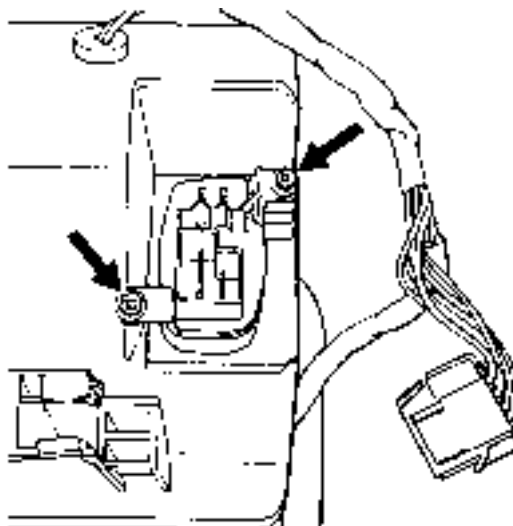

K1 00 957

3. Fit the connector to the cover.
4. Fit the dashboard panels on the underside.

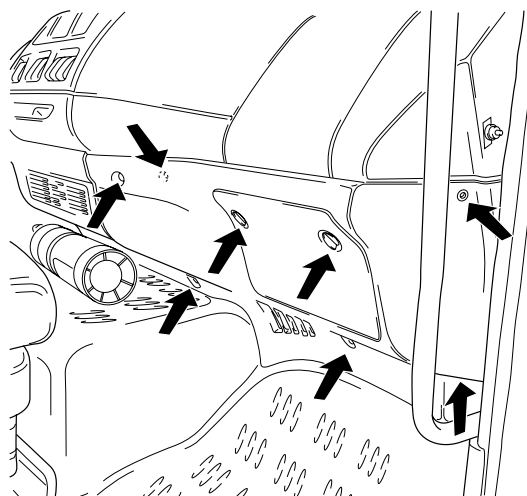

K1 01 133

3.6 REMOVAL AND INSTALLATION, HEATER RADIATOR

Removing the heater radiator

1. Remove the heater unit.
2. Remove the cover.

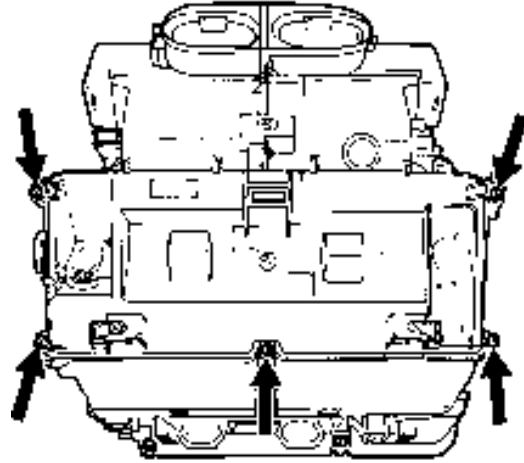

K1 00 953

3. Detach the connectors from the air conditioning thermostat and remove the series resistor.

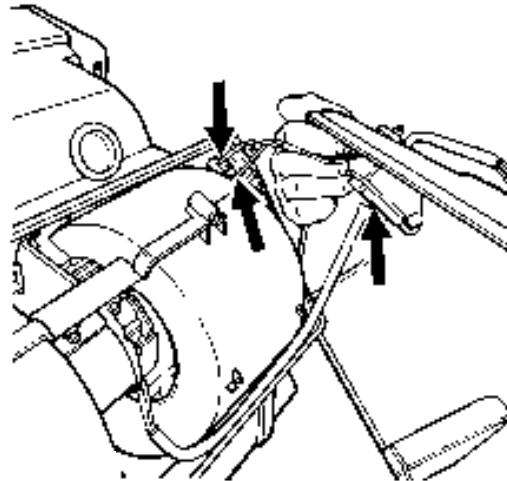

K1 00 954

4. Remove the heater motor.

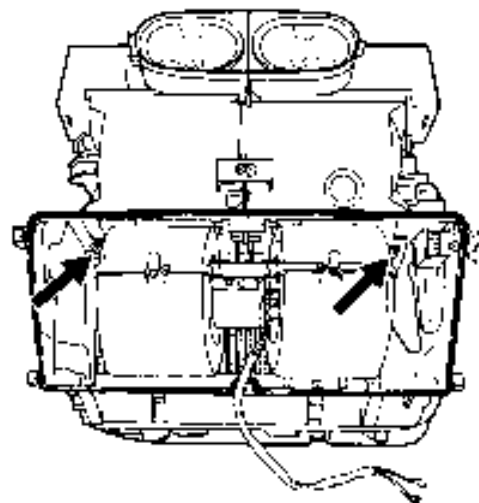

K1 00 955

5. Remove the attachment bolts from the air conditioning thermostat. Remove the capillary tube from the evaporator.

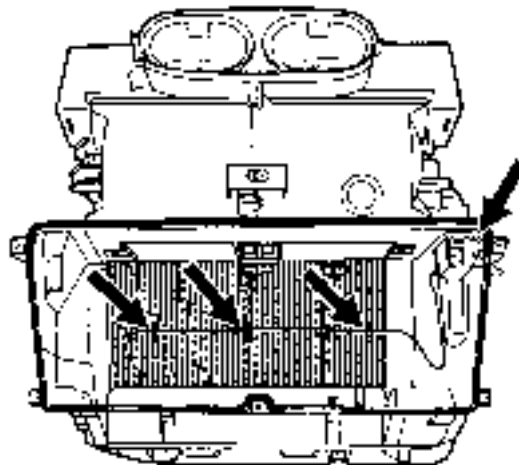

K1 00 959

6. Remove the fastening clip from the control cable and remove the heater valve.

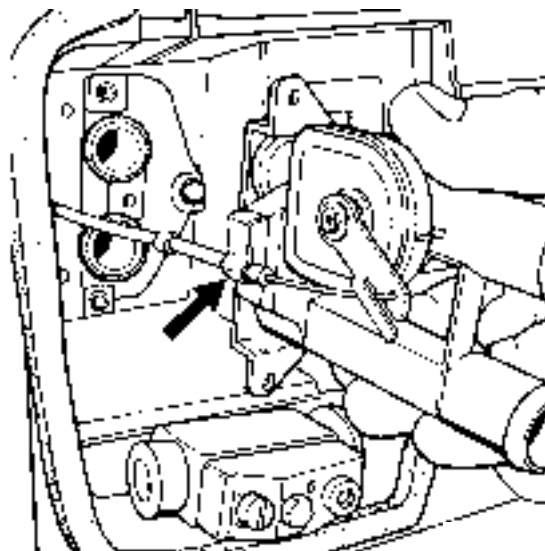

K1 00 961

7. Remove the attachment bolts from the heater valve holder.
8. Remove the O-rings.

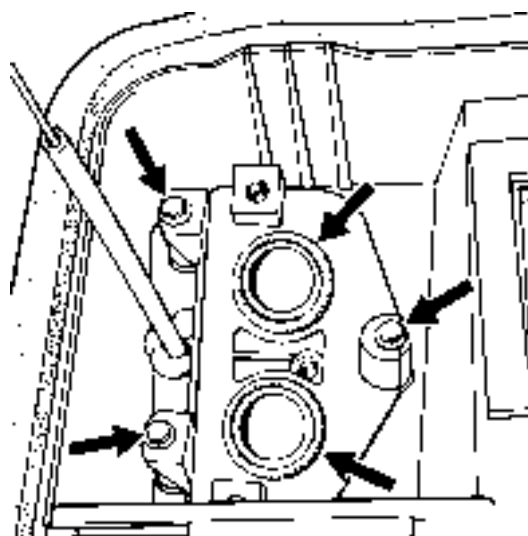

K1 00 962

9. Remove the attachment bolt from the heater pipe fastening.

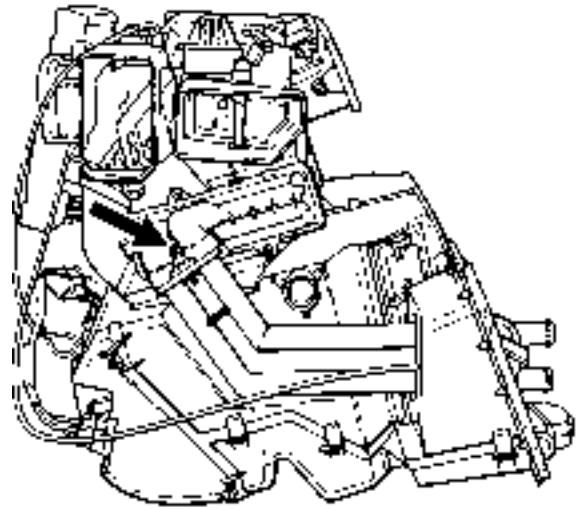

K1 00 963

10. Remove the heater pipes and remove the O-rings.

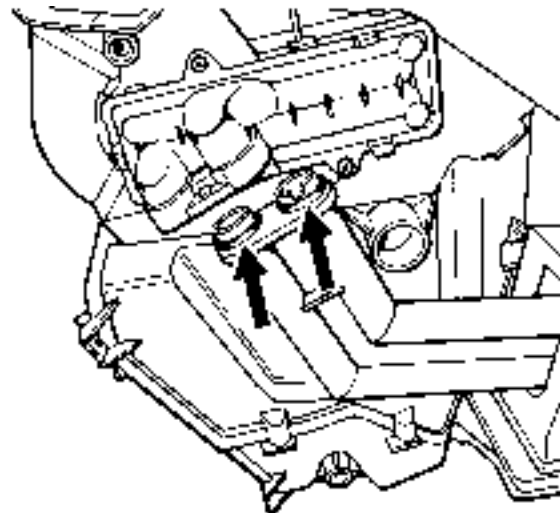

K1 00 964

11. Remove the radiator attachment bolts.

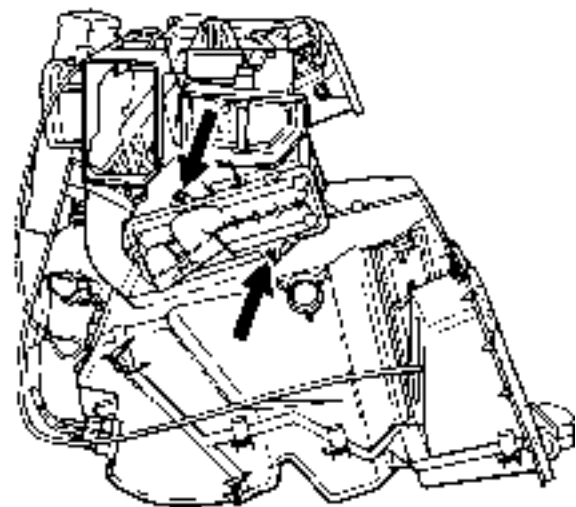

K1 00 965

12. Push the retainer aside.

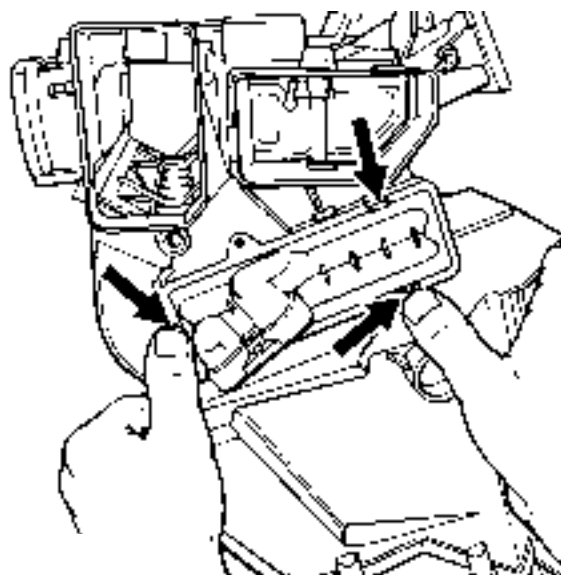

K1 00 966

13. Remove the radiator.

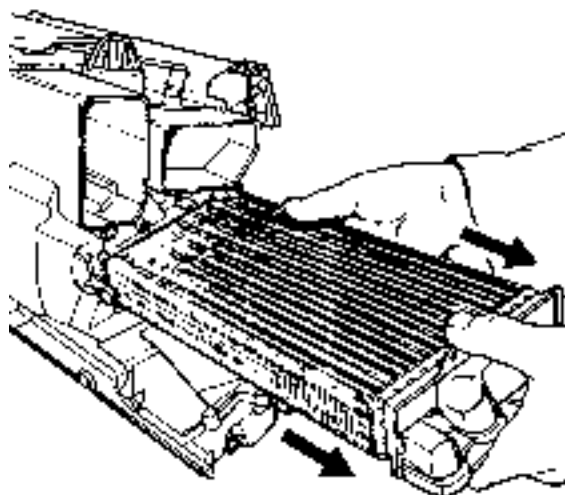

K1 00 967

Installing the heating radiator

1. Install the heater radiator in the heating unit.
2. Press the heater radiator into the retainer.
3. Fit the heater radiator attachment bolts.
4. Fit new O-rings and fit the heater pipes.
5. Secure the heater pipe with the attachment bolt.
6. Fit the heater valve holder and secure it using the attachment bolts.
7. Fit the control cable to the heater valve and secure it using the fastening clip.
8. Install the heater motor.
9. Fit the air conditioning thermostat connectors and the series resistor.
10. Fit the heater motor cover.
11. Fit the heater unit.

CONTENTS

	Page	Date
1. SAFETY INSTRUCTIONS	1-1	0210
2. GENERAL	2-1	0210
2.1 Description of exterior mirrors	2-1	0210
2.2 Description of windscreen wiper and washers	2-2	0210
2.3 Description of headlight levelling	2-2	0210
3. INSPECTION AND ADJUSTMENT	3-1	0210
3.1 Inspection and adjustment, headlights	3-1	0210
4. REMOVAL AND INSTALLATION	4-1	0210
4.1 Removal and installation, windscreen wiper system	4-1	0210
4.2 Removal and installation, entrance step grille	4-3	0210
4.3 Removal and installation, entrance step support	4-3	0210
4.4 Removal and installation, door	4-4	0210
4.5 Removal and installation, corner piece	4-6	0210
4.6 Removal and installation, lattice grille	4-6	0210
4.7 Removal and installation, grille	4-7	0210
4.8 Removal and installation, lattice of headlight cover panel	4-7	0210
4.9 Removal and installation, headlight cover panel	4-8	0210
4.10 Removal and installation, roof hatch	4-10	0210
4.11 Removal and installation, bumper	4-11	0210
4.12 Removal and installation, windscreen	4-12	0210
4.13 Removal and installation, rear window glass	4-17	0210
4.14 Removal and installation, door glass	4-19	0210
4.15 Removal and installation, exterior mirror glass	4-20	0210
4.16 Removal and installation, exterior mirrors complete with arms	4-22	0210
4.17 Removal and installation, pavement mirror	4-23	0210
4.18 Removal and installation, dead angle exterior mirror	4-23	0210
4.19 Removal and installation, headlight	4-24	0210
4.20 Removal and installation, headlight bracket	4-24	0210
4.21 Removal and installation, headlight levelling control	4-25	0210
4.22 Removal and installation, mudguard assembly	4-25	0210

1. SAFETY INSTRUCTIONS

General

The cab is equipped with a hydraulic tilting gear. The pump is located on co-driver's side at the rear of the cab. The cab locks are opened hydraulically during pumping.

Before tilting the cab, make sure that the doors are closed, that there are no loose items in the cab and that the gear lever is in neutral. Tilt the cab fully forward if work is to be carried out underneath the cab.



You can stop the cab tilting forward at any time by turning the cock to the reverse tilting position.



When working on a tilted cab (for example when welding, spray-painting or applying bitumen coatings), be sure to cover the piston rod of the lifting cylinder. Welding spatter and paint on the piston rod will inevitably cause damage to the oil seal.

Inspection after a collision

Before tilting the cab after a collision, check the cab rests, the cab hinges and the attachment of the lifting cylinder to the chassis member and cab for cracks.



If the vehicle has been involved in a collision, the cab must under no circumstances be tilted without due precautions. The end stop in the lifting cylinder may be damaged, which might cause the cab to shoot past its end stop.

If possible, suspend the cab in slings and put a stand in front of the cab. Make sure that there is no one in front of the cab while it is being tilted.

Replacing the lifting cylinder

After a collision, **always** check the lifting cylinder for internal damage.

Replace the lifting cylinder if damaged or if you are in doubt as to the its condition.

Always replace the cylinder if one of the following points has occurred during a collision:

- A. the cab has been pulled out of the cab locks,
- B. the cab locks have been deformed or damaged,
- C. the rear cab springs have been deformed or damaged.

2. GENERAL

2.1 DESCRIPTION OF EXTERIOR MIRRORS

All exterior mirrors and exterior mirror arms used are factory set for average driving conditions. After the superstructure has been constructed on the vehicle, it is required by law that all exterior mirrors and exterior mirror arms should be re-adjusted in accordance with EC Directive 88/321. This critical adjustment depends entirely on the width of the vehicle's superstructure.

To ensure proper adjustment of the exterior mirror/external mirror arms as provided for in the Directive, it is important to follow all adjustment procedures closely.

Exterior mirror classification

This section describes the different types of vehicle exterior mirrors according to the standard EC exterior mirror classification. The following vehicle exterior mirror categories apply to trucks over 7.5 tonnes:

- "Category 2" - Main exterior mirror
- "Category 4" - Wide angle exterior mirror
- "Category 5" - Close-up exterior mirror

Note:

Category 1 (inside) and category 3 (exterior) mirrors are intended for passenger cars.

The exterior mirror consists of convex glass and an aerodynamically shaped mirror housing. The main exterior mirror and wide-angle exterior mirror (only on co-driver side) are fitted to a D-shaped arm on the door. The pavement mirror is attached to the upper part of the door on a separate bracket.

The exterior mirror bracket returns to its original position if it gets flapped back. On several models there is an extra exterior mirror (apart from a pavement mirror) on co-driver side giving the driver a better view of the drawn vehicle.

The main exterior mirror heating and the windscreen heating, can be turned on by a switch on the dashboard. When the exterior mirror heating is turned on, the warning lamp in the switch lights up.

The exterior mirrors can be divided into:

- non-heated exterior mirrors
- heated exterior mirrors (except for pavement mirror) in combination with windscreen heating

2.2 DESCRIPTION OF WINDSCREEN WIPER AND WASHERS

There are two windscreen wipers which are equipped with nozzle tips, each of which has three spray nozzles. The high-pressure pump for this washing system abuts the storage tank. The washers are underneath the headlights.

The filler opening of the storage tank for the windscreen washers and possibly the headlight washers is located in the stepwell on driver's side.

2.3 DESCRIPTION OF HEADLIGHT LEVELLING

The cab is equipped with an internal device for adjusting the angle of the headlight beam. Control is by a rotary knob located in the cab. The knob is situated on the dashboard to the right of the steering wheel. The headlights are levelled by means of electric motors located at the bottom of the headlight unit.

3. INSPECTION AND ADJUSTMENT

3.1 INSPECTION AND ADJUSTMENT, HEADLIGHTS

Note:

Use adjustment equipment to check and adjust the headlights.

Adjustment, headlamps

1. When adjusting the headlights, check that:
 - the vehicle is unladen and the tyres are inflated to the specified pressure.
 - the vehicle is standing on a flat and level surface.
 - inside the cab the height adjustment of the headlights is in "0"-position.
2. The headlight can be adjusted by four knurled knobs at the rear of the headlight housing; main beam and dipped beam can be adjusted separately:
 - To adjust the dipped beam horizontally, turn knob 1.
 - To adjust the dipped beam vertically, turn knob 2.
 - To adjust main beam horizontally, turn knob 3.
 - To adjust the main beam vertically, turn knob 4.

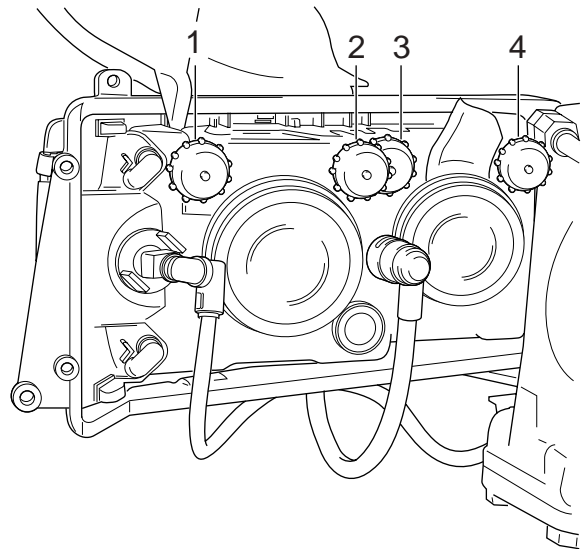

K1 01 156

3. As clear headlight glass is used the image of the asymmetrical light beam deviates slightly from the usual image. The beam of light is not a straight line that slants upwards, but is slightly convex.
4. Adjust the headlight in such a manner that the intersection of the convex and the horizontal light beam coincides with the intersection of the asymmetrical diagonal and the horizontal adjustment line. It does not matter that the light beam convex is above the asymmetrical diagonal.

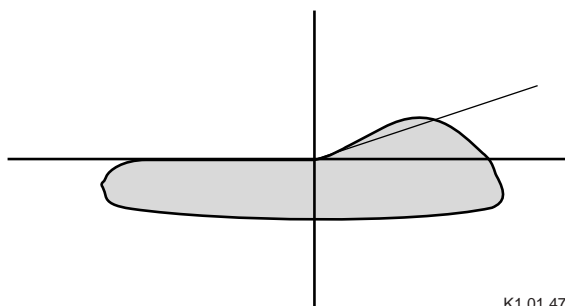

K1 01 473

4. REMOVAL AND INSTALLATION

4.1 REMOVAL AND INSTALLATION, WINDSCREEN WIPER SYSTEM

Notes:

Before replacing the wiper linkage, the following points must be observed.

If the bearings of the wiper linkage are worn, replace them as well as the linkage.

Use the correct tools when removing old linkage in order to avoid damaging the seals.

Use FINA Ceran-grease for new linkage.

When fitting new linkage, never hit the sealing covers of the linkage with a hammer or other hard object. These covers are only 1 mm thick and might suffer damage in this way.

If the motor shaft shows evidence of axial play, replace the motor. This play will cause excessive wear to the wiper linkage.

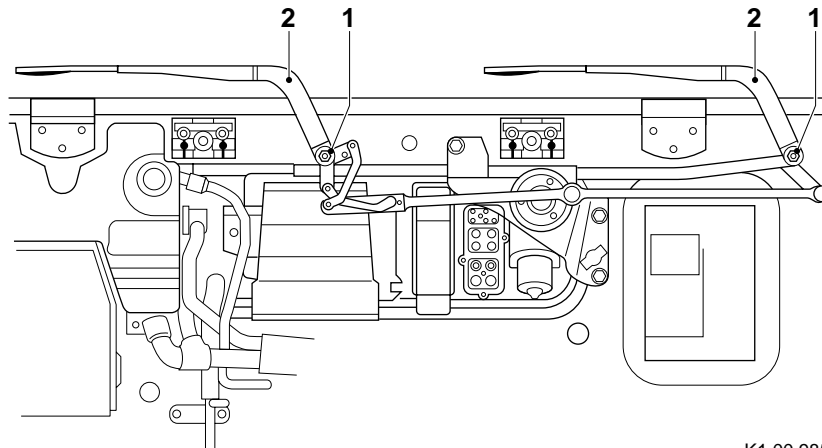

K1 00 985

Removing the windscreen wiper system

1. Remove the attachment nuts (1) from the windscreen wiper arms and remove the windscreen wiper arms (2) using a pulley puller (trade tool).

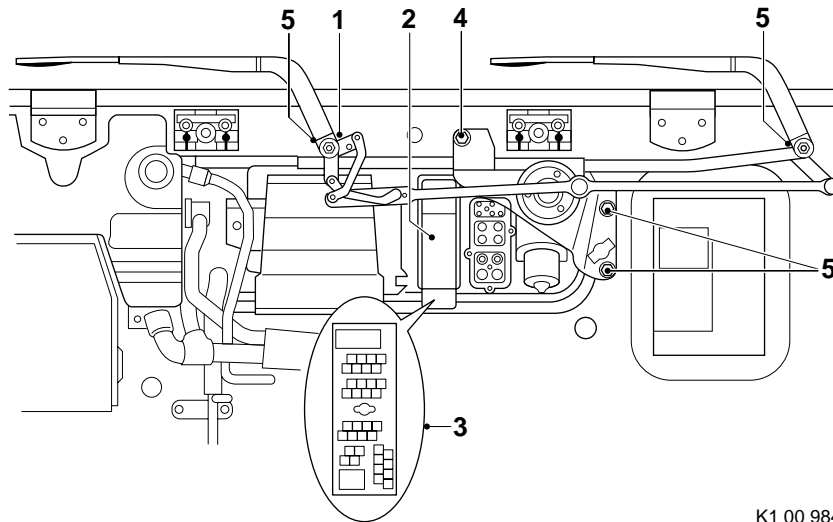

K1 00 984

4

2. Remove the hose for the windscreen wiper fluid (1).
3. Remove the protecting plate (2).
4. Remove the connectors (3).
5. Remove the attachment nut (4).
6. Remove the attachment bolts (5) and remove the windscreen wiper mechanism.

Installing the windscreen wiper mechanism

1. Fit the windscreen wiper mechanism with the attachment bolts (5).
2. Fit the attachment nuts (4).
3. Fit the connectors (3).
4. Fit the protecting plate (2).
5. Fit the hose for the windscreen wiper fluid (1).
6. Put the windscreen washer motor in the neutral position by turning it on and off quickly using the switch in the cab.
7. Fit the windscreen wiper arms.

4.2 REMOVAL AND INSTALLATION, ENTRANCE STEP GRILLE

Removing the stepwell and entrance step support

1. Remove the attachment bolts (1) from the stepwell.
2. Remove the grille.

Installing the stepwell and entrance step support

1. Fit the grille.
2. Secure the grille with the attachment bolts (1).

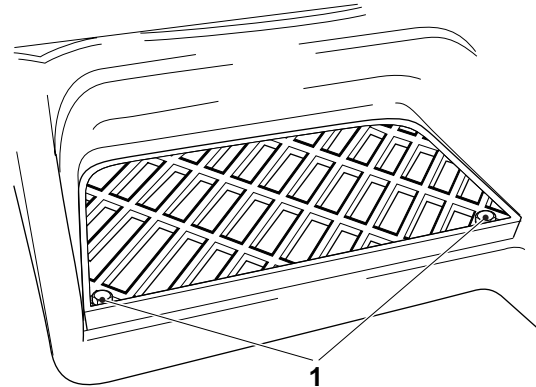

K1 00 987

4.3 REMOVAL AND INSTALLATION, ENTRANCE STEP SUPPORT

Removing the entrance step support

1. Tilt the cab forward.
2. Remove the attachment bolts (1).
3. Remove the bracket from the entrance step.

Installing the entrance step support

1. Fit the bracket.
2. Secure the bracket with the attachment bolts (1).
3. Tilt the cab back.

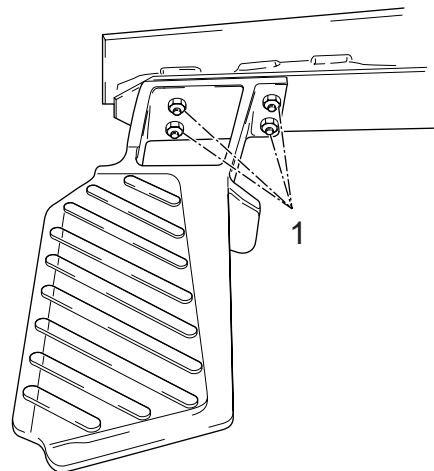

K1 01 151

4.4 REMOVAL AND INSTALLATION, DOOR**Removing the door**

1. Remove the corner piece.
2. Wind the door glass down.
3. Remove the attachment nut (1).
4. Remove the pin (2).

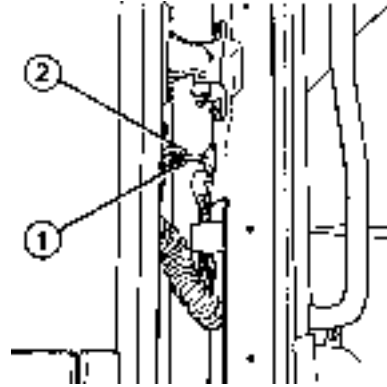

K1 00 979

5. Suspend the door in a hoist using a sling (1).

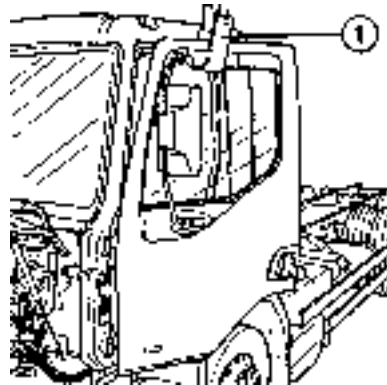

K1 00 980

6. Remove the cover caps (1).
7. Detach the connector from the holder (3) and take the connector (2) apart.
8. Remove the fitted bolts.
9. Remove the door.

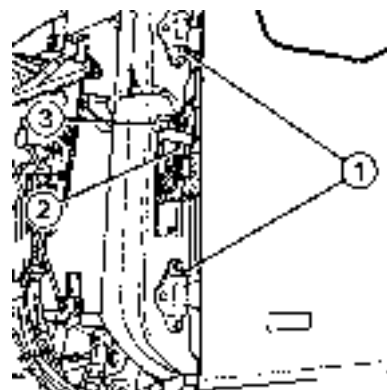

K1 00 981

Installing the door

1. Install the door.
2. Place the fitted bolts and tighten them.
3. Fit the cover caps (1).
4. Reassemble the connector (2) and fit it in the holder (3).

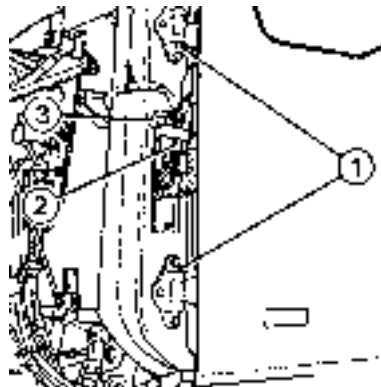

K1 00 981

5. Fit the pin (2).
6. Fit the nut (1).
7. Remove the hoist and close the door glass.
8. Fit the corner piece.

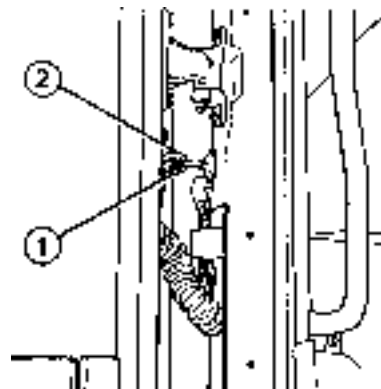

K1 00 979

4.5 REMOVAL AND INSTALLATION, CORNER PIECE

Removing the corner piece

1. Open the grille and remove the attachment bolts (1).



K1 00 982

2. Open the door and remove the attachment bolts (1).
3. Remove the corner piece (2).

Installing the corner piece

1. Fit the corner piece.
2. Secure the corner piece (2) in the door post and at the front of the cab, using the attachment bolts (1).
3. Close the grille.

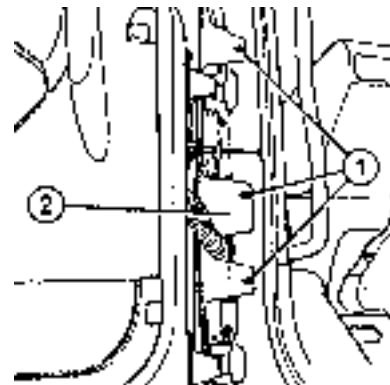

K1 00 983

4.6 REMOVAL AND INSTALLATION, LATTICE GRILLE

Removing the lattice grille

1. Open the grille.
2. Remove the attachment bolts from the lattice.
3. Remove the lattice.

Fitting the lattice grille

1. Fit the lattice.
2. Secure the lattice using the attachment bolts.
3. Close the grille.

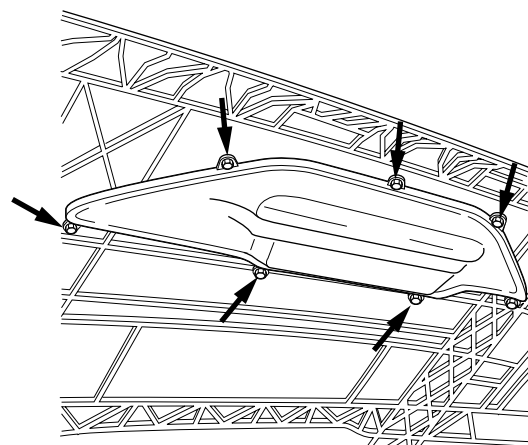

K1 00 991

4.7 REMOVAL AND INSTALLATION, GRILLE

Removing the grille

1. Open the grille and support it.
2. Remove the locking clips from the gas spring attachment and remove the gas springs.
3. Remove the attachment bolts from the grille and remove the grille.

Installing the grille

1. Position the grille and secure it using the attachment bolts.
2. Support the grille when open and install the gas springs using the locking clips.
3. Close the grille.

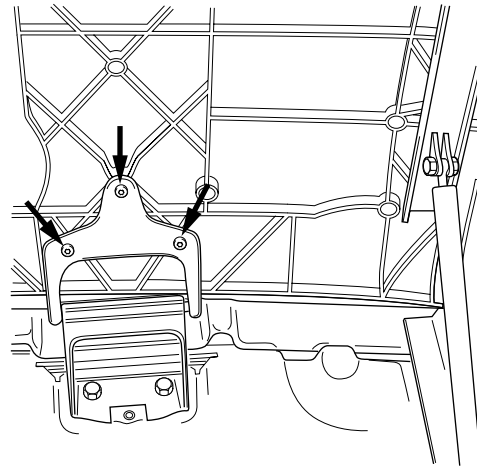

K1 00 992

4

4.8 REMOVAL AND INSTALLATION, LATTICE OF HEADLIGHT COVER PANEL

Removing the lattice from the headlight cover panel

1. Loosen the attachment screws (1) by $\frac{1}{4}$ -of a turn.
2. Remove the lattice (2).

Fitting the lattice of the headlight cover panel

1. Fit the lattice (2).
2. Position the slot of the attachment screws (1) horizontally and push them in place.

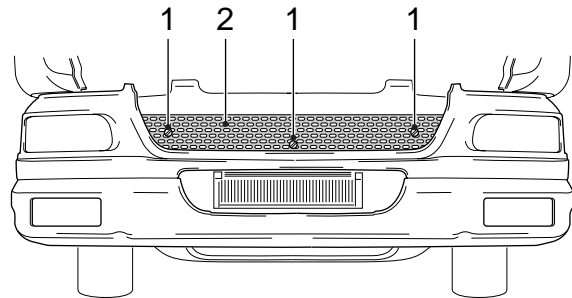

K1 01 157

4.9 REMOVAL AND INSTALLATION, HEADLIGHT COVER PANEL

Removing the headlight cover panel

1. Remove the lattice from the cover panel.
2. Remove the attachment bolts (1) from behind the lattice.
3. Remove the attachment bolts with nuts (3 and 4) at the rear of the headlight cover panel.
4. Remove the nuts (2).

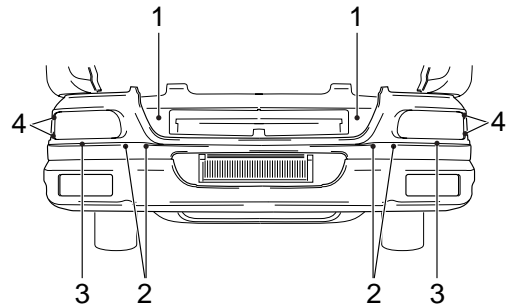

K1 01 185

5. Remove the attachment bolts (1) on either side and remove the covers.

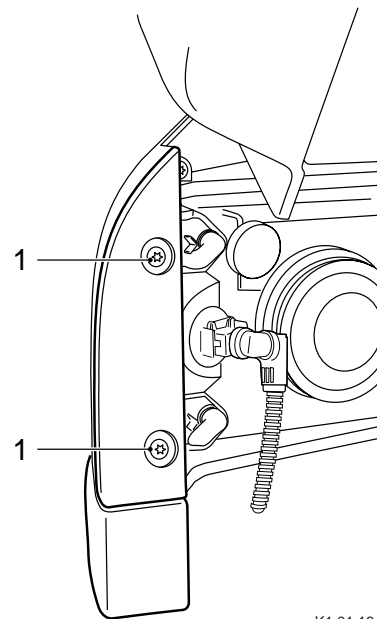

K1 01 184

6. Remove the attachment bolts (1).
7. Remove the headlight cover panel.

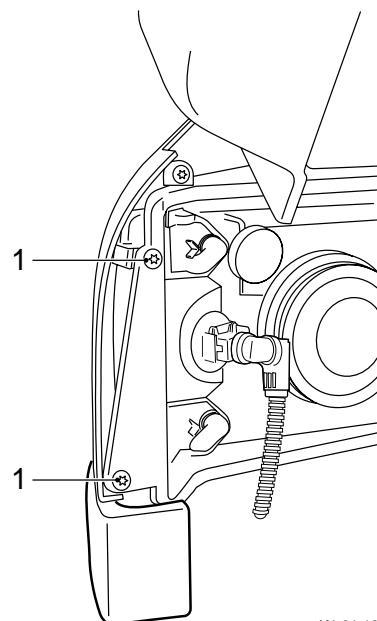

K1 01 199

1

EXTERNAL CAB COMPONENTS

LF45/55 series

Removal and installation

Installing the headlight cover panel

1. Fit the headlight cover panel.
2. Insert the attachment bolts (1).
3. Fit the attachment bolts and nuts (3 and 4) on the rear side of the cover panel.
4. Fit the nuts (2).

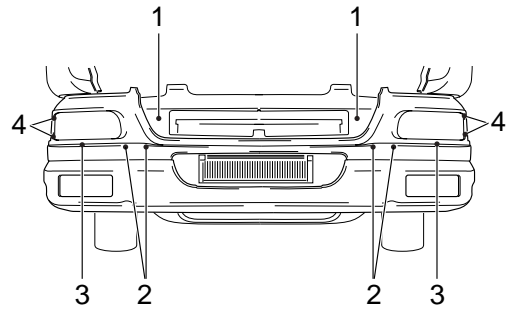

5. Insert the attachment bolts (1).

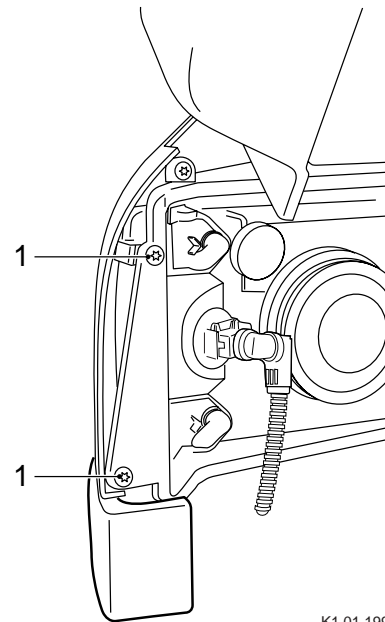

6. Fit the cover panel. Secure it using the attachment bolts (1).
7. Fit the lattice to the cover panel.

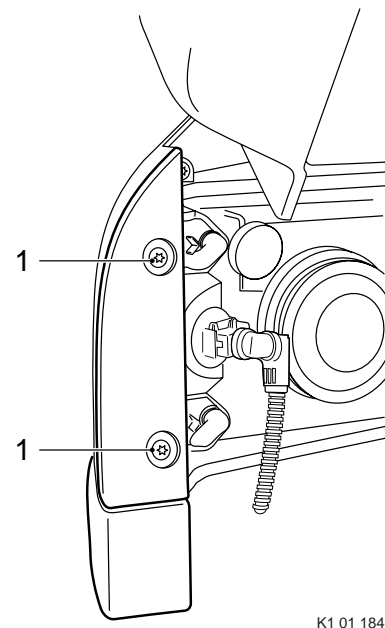

4.10 REMOVAL AND INSTALLATION, ROOF HATCH

Removing the roof hatch

1. Remove the attachment bolts from the roof hatch weather strip.
2. Remove the roof hatch weather strip.

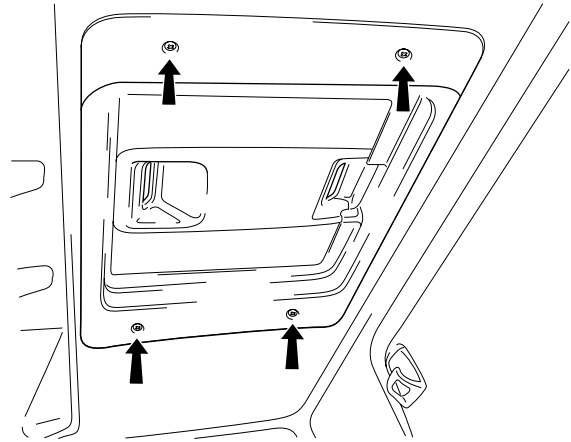

K1 01 159

3. Remove the roof hatch attachment bolts.

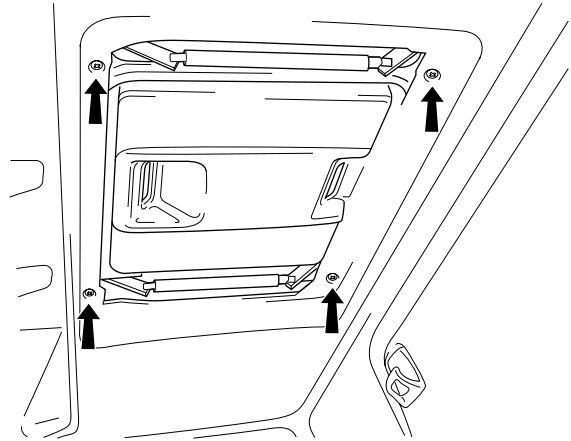

K1 01 160

4. Remove the roof hatch.

Installing the roof hatch

1. Install the roof hatch.
2. Tighten the attachment bolts evenly.
3. Fit the roof hatch weather strip.
4. Secure the roof hatch weather strip with the attachment bolts.

4.11 REMOVAL AND INSTALLATION, BUMPER

Removing the bumper

1. Remove the attachment bolts on the underside of the bumper (1).
2. Remove the attachment bolts (2) on the top of the bumper (1). These attachment bolts can be reached using an open-end spanner on the rear of the bumper.
3. If applicable, remove the lighting connectors.

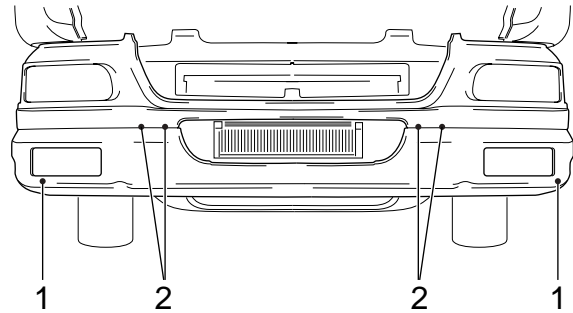

K1 01 132

Installing the bumper

1. Fit the bumper.
2. Position the bumper. Secure the attachment bolts (1 and 2) on the top and underside.
3. If applicable, fit the lighting connectors.

4.12 REMOVAL AND INSTALLATION, WINDSCREEN

Removing the windscreen

1. Remove the grille.
2. Take the cover panel out of the window frame.
3. Remove the windscreen wiper arms.
4. Remove the plastic cover strips on the inside of the front-screen pillars (A-pillar).
5. Protect the curved areas on the outside of the windscreen frame with linen tape. Also use tape to protect the plastic parts on the inside and the defroster openings of the heating and ventilation system.

Note:

Take care not to damage the paint.

6. Put the wire (special tool, DAF no. 1329415) at approximately the middle of the upper and lower side of the glass using pliers or a special pass-through tool (special tool, DAF no. 1240458) through the sealant.

Note:

Remove the wire pass-through tool before fitting the wire ends to the handles of the cutting wire set.

7. The length of the cutting wire should be 1.5 x the height of the windscreen.
8. Secure the handles that are part of the set, special tool (DAF no. 0499817) to the cutting wire.

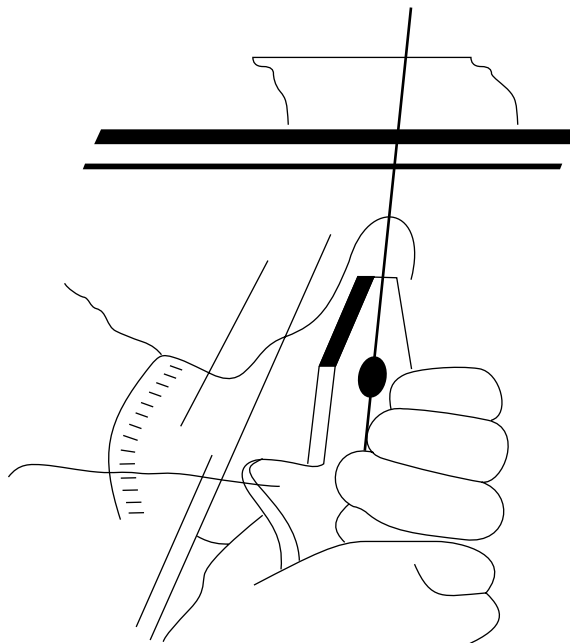

K1 00 715

9. Use tape strips to protect the glass from falling out accidentally (after the sealant has been cut through).
10. Start the cutting in the middle. Make sure the wire is kept moving and tightly stretched all the time. If the wire gets twisted, it will inevitably break.
11. Keep the cutting wire as close as possible to the edge of the glass.
12. Make sure the wire ends are crossed before the bottom corners are reached.
13. Take the windscreen out of the frame using the two suction pads, special tool (DAF no. 0484800).
14. Remove any remaining sealant in the window frame with a scraper, special tool (DAF no. 1329417). Make sure the remaining layer of sealant has a thickness of at most 1 to 1.5 mm and that it is flat and smooth.
15. Remove frayed pieces and granules of old sealant and clean the frame thoroughly with a cleaner.

Important tips

- If the new windscreen is fitted at a later time, the old, fully cured sealant should be cleaned 15 minutes before the glass is fitted, to ensure proper adhesion.
- Repair any damage to the paint on the window frame immediately with the right type of paint.
- Always work in a clean area.
- Wear industrial gloves or use a special hand cream.
- Use paper towels or tissues instead of cleaning rags.

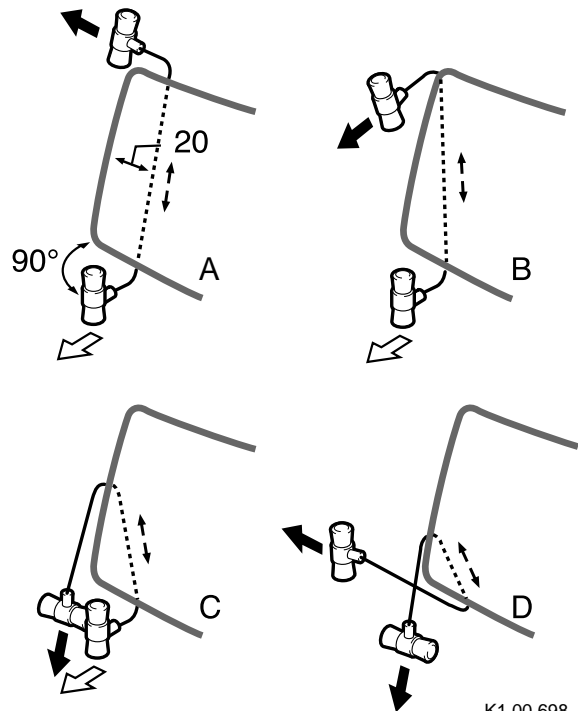

K1 00 698

Installing the windscreen



Be careful when using cleaner. Contact with the cleaner will cause skin irritation and swallowing will cause burning. Inhaling may cause breathing problems.

1. Any damage to the paint should be repaired well before the windscreen glass is placed. Use the right type of paint.
2. Make sure that the guide rail is smooth and flat (no major irregularities).
3. Check the windscreen for damage.
4. Attach two double suction pads, special tool (DAF no. 0484800) to the outside of the glass.
5. Put the windscreen with the suction pads on a completely clean workbench.
6. Fit the rubber trimming to the glass and secure it with tape on the outside of the glass.
7. Place the glass in the frame without using sealant, starting at the bottom and ensuring that it fits exactly in the frame. If necessary, fill up the rubber spacer blocks by means of which the glass rests on the support blocks.
8. Mark the correct position of the glass in the frame with strips of tape. Cut through the tape in the frame.
9. Remove the glass from the frame and place the glass on the workbench.
10. Clean the glass where the layer of sealant is to be applied. See "Technical data".
11. Clean the sealant within the frame.

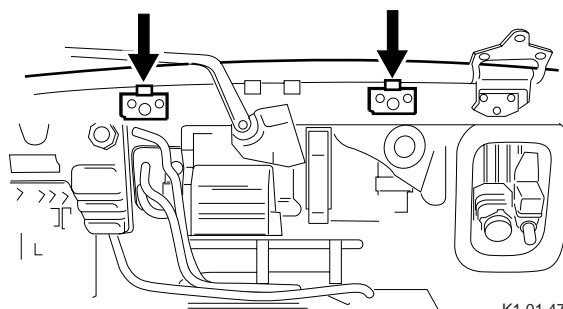

K1 01 474

Applying sealant

1. For hot processing, the adhesive should be heated in an oven, special tool (DAF no. 1329416) for 60 minutes at 80°C.
2. Apply the sealant to the rubber as indicated in the diagram. There is no rubber on the underside of the windscreen. Here, the seal beads must be 11 mm from the edge of the glass.

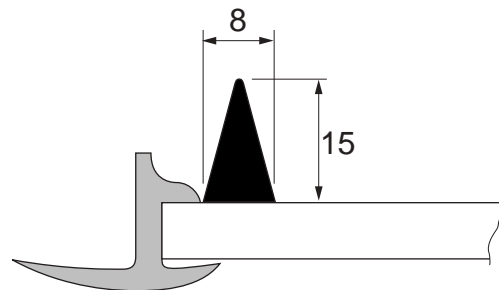

K1 01 215

3. Take note of the processing time when applying the sealant. See "Technical data".
4. Place the sealant gun with the opening 90°/60° onto the windscreen and move it evenly to build up a good layer.
5. Avoid air bubbles in the layer of sealant.

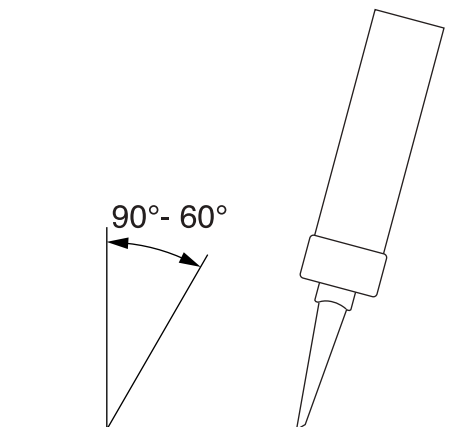

K1 00 722

Note:

If a pneumatic glue gun is used for sealing (special tool DAF no 1240444) then before beginning adjust the pressure in the gun by spraying several test strips.

Fitting the glass

1. For safety, open the windows to avoid undesirable pressure build-up on the windscreen.
2. The glass should be taken from the workbench by two persons and it should be placed in the frame in one go. Use the tape strips to determine the correct position.
3. Make sure that the rubber windscreen trim on the bottom seats properly into the frame.

4. Use a sealant remover to remove the excess sealant immediately from the painted parts, see "Technical data".
5. Depending on the type of sealant used (hardening time), fit straps. See "Technical data". Protect the paint by fitting linen tape in the places where the straps will touch the paint.
6. If applicable, pull two strips round the outside of the windscreen and the cab pillar. Put strips of wood or Tempex underneath to avoid damage.
7. Let the sealant harden. See "Technical data".
8. Remove from the cab body all the tape used for protection and marking.
9. Clean the entire windscreen and the parts of the cab body which have been fouled during installation of the windscreen using a glass cleaner.
10. Fit the A-pillar trimming panels in the cab.
11. Fit the cover panel to the window frame.
12. Fit the windscreen wipers and adjust them.
13. Fit the grille.
14. If the vehicle is fitted with an airbag, apply a new airbag sticker to the windscreen.



K1 01 426

4.13 REMOVAL AND INSTALLATION, REAR WINDOW GLASS

Removing the rear window glass

1. Remove the cover panel attachment bolts. Remove the cover panels.
2. Attach a suction pad (DAF no. 0484800).
3. Put the wire (special tool, DAF no. 1329415) at approximately the middle of the upper and lower side of the glass using pliers or a special pass-through tool (special tool, DAF no. 1240458) through the sealant.

Note:

Remove the wire pass-through tool before fitting the wire ends to the handles of the cutting wire set.

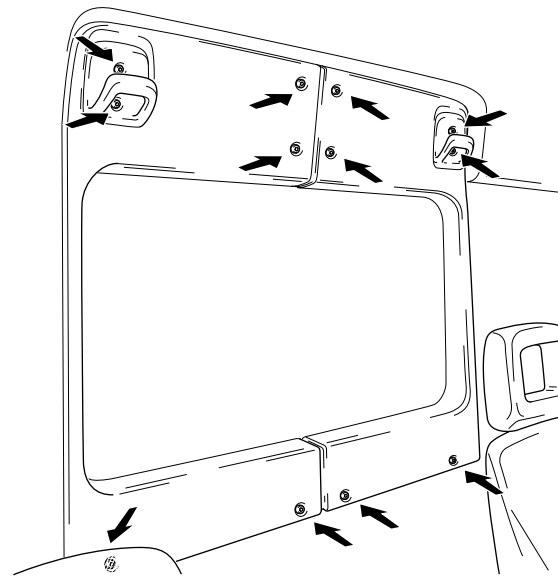

K1 01 131

4. The length of the cutting wire should be 1.5 x the height of the window.
5. Secure the handles that are part of the set, special tool (DAF no. 0499817) to the cutting wire.
6. Use tape strips to protect the glass from falling out accidentally (after the sealant has been cut through).
7. Start cutting in the middle. Make sure the wire is kept moving and tightly stretched all the time. If the wire gets twisted, it will inevitably break.
8. Keep the cutting wire as close as possible to the edge of the glass.
9. Make sure the wire ends are crossed before the bottom corners are reached.
10. Take the glass out of the frame using a suction pad, special tool (DAF no. 0484800).

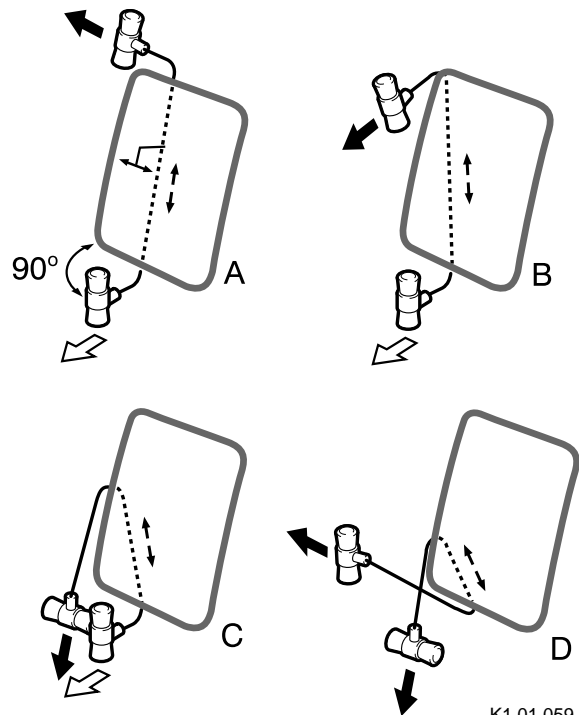

K1 01 059

11. Remove any remaining sealant in the window frame with a scraper, special tool (DAF no. 1329417). Make sure the remaining layer of sealant has a thickness of at most 1 to 1.5 mm and that it is flat and smooth.
12. Remove frayed pieces and granules of old sealant and clean the frame thoroughly with a cleaner.

Fitting the rear window glass

1. If necessary, smooth off spare sealant.
2. Apply the adhesive (1) as shown.
3. Fit the spraying nozzle to the cartridge and apply the sealant to the window, spraying as evenly as possible.

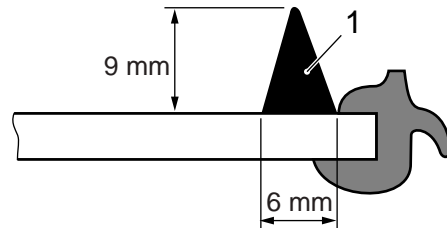

K1 01 178

4. Place the sealant gun with the opening 90°/60° onto the windscreen and move it evenly to build up a good layer.
5. Avoid air bubbles in the layer of sealant.

Note:

If a pneumatic glue gun is used for sealing (special tool DAF no 1240444) then before beginning adjust the pressure in the gun by spraying several test strips.

6. Pay attention to the processing time, see "Technical data".
7. Fit the rear window glass and press it into the frame. Secure the glass in several places with strips of tape around 20 cm long. Open the door windows to prevent pressure in the cab.

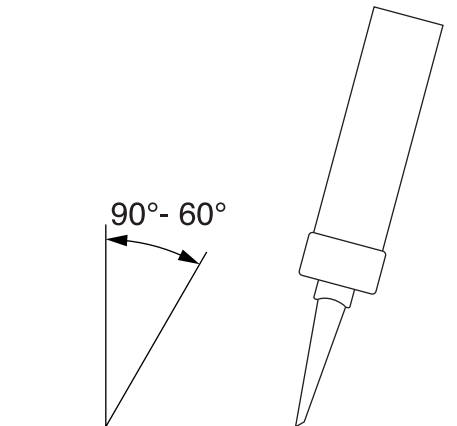

K1 00 722

8. Let the sealant harden. See "Technical data".
9. Remove from the cab body all the tape used for protection and marking.
10. Clean the entire window and the parts of the cab body which have been fouled during installation of the window glass using a glass cleaner.

4.14 REMOVAL AND INSTALLATION, DOOR GLASS

Removing door glass

1. Remove the complete window mechanism.
2. Tilt the door glass (1).
3. Remove the door window from below.

Installing door glass

1. Fit the door window from below.
2. Fit the window mechanism.

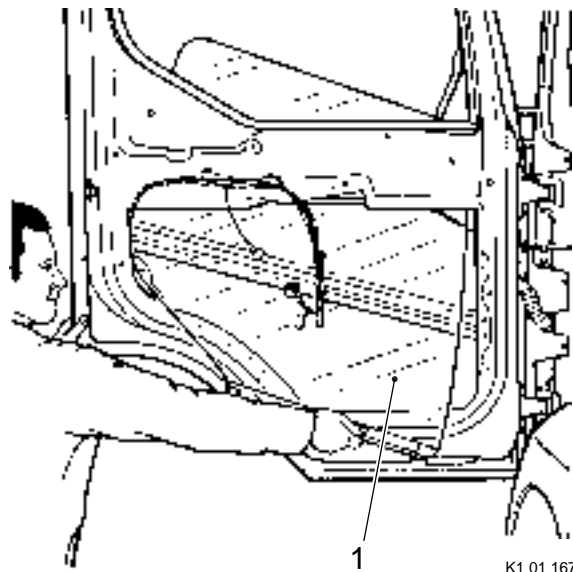

K1 01 167

4.15 REMOVAL AND INSTALLATION, EXTERIOR MIRROR GLASS

Removing mirror glass

1. Push in the cover (1) of the mirror housing (5) at the notches. Remove the cover (1) from the exterior mirror housing (5).
2. Disconnect the electrical exterior mirror adjustment connector (7), if applicable.
3. Disconnect the exterior mirror heating connector (9).
4. Remove the attachment bolts (2) from the clamping brackets (3). Mark the position. Remove the outside mirror housing (5).
5. Remove the attachment bolts (4) from the mirror glass holder (8). Push the mirror glass holder (8) out of the mirror housing (5).
6. If fitted, remove the attachment screws (6) from the electrical exterior mirror adjustment (7). Mark the position of the electrical mirror adjustment (7). Remove the electrical mirror adjustment (7) from the mirror glass holder (8).
7. Place the exterior mirror glass holder (8) in a hot water bath of approx. 80°C. Allow the mirror glass holder (8) and mirror (10) to heat for fifteen minutes.
8. Wear isolating gloves to prevent burns. Take the exterior mirror glass holder (8) out of the hot water bath. Carefully press one side of the mirror (10) out of the mirror glass holder (8).
9. Carefully remove the exterior mirror (10) from the mirror glass holder (8).

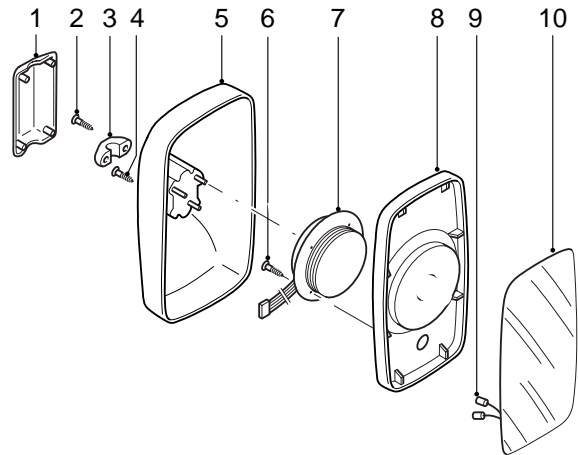

K1 01 258

Installing exterior mirror glass

1. Place the exterior mirror glass holder (8) in a hot water bath of approx. 80°C. Allow the mirror glass holder (8) to heat for fifteen minutes.
2. Wear isolating gloves to prevent burns. Take the exterior mirror glass holder (8) out of the hot water bath. Insert the wires of the electrical exterior mirror heating (9) through the grommet in the exterior mirror glass holder (8).
3. Place one side of the mirror glass (10) in the groove of the mirror glass holder (8). Press the edges of the mirror glass holder (8) carefully over the mirror glass (10).
4. Allow the mirror glass holder (8) to cool down.
5. If applicable, fit the electrical exterior mirror adjustment (7) to the mirror glass holder (8), using the attachment bolts (6). Note the fitting position.
6. Fit the exterior mirror glass holder (8) in the mirror housing (5) using the attachment bolts (4). Note the fitting position and the electrical connectors.
7. Fit the mirror housing (5) to the mirror arm, using the attachment bolts (2) and the clamping brackets (3).
8. If applicable, connect the electrical connectors of the electrical mirror adjustment (7) and the mirror heating (9).
9. Fit the cover (1) to the exterior mirror housing (5).

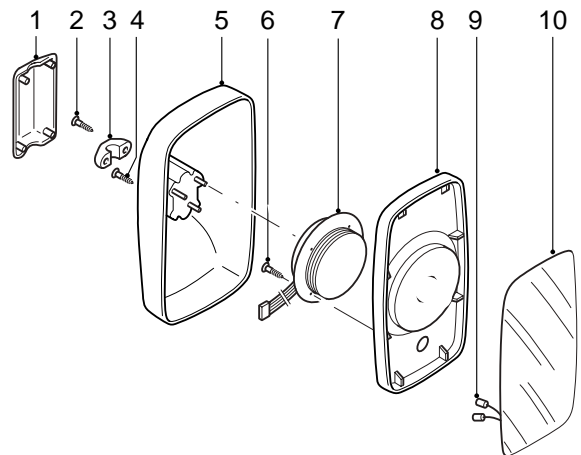

K1 01 258

4.16 REMOVAL AND INSTALLATION, EXTERIOR MIRRORS COMPLETE WITH ARMS

Removing the exterior mirror assembly

1. Remove the attachment bolts (1) and remove the exterior mirror assembly with the covers (2).

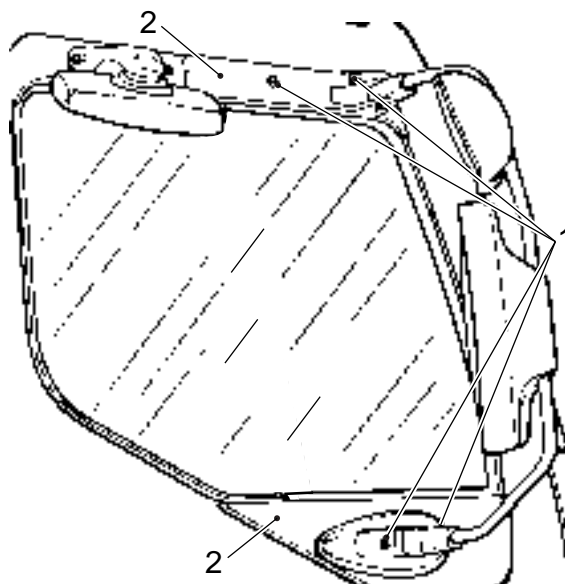

K1 01 168

2. Remove the connector (1).
3. Remove the exterior mirror assembly with the covers.

Installing the exterior mirror assembly

1. Fit the connector (1).
2. Fit the exterior mirror assembly with arm and the covers.
3. Secure the mirror with the attachment bolts. Ensure that the rubber O-rings are fitted between the cover and the door.

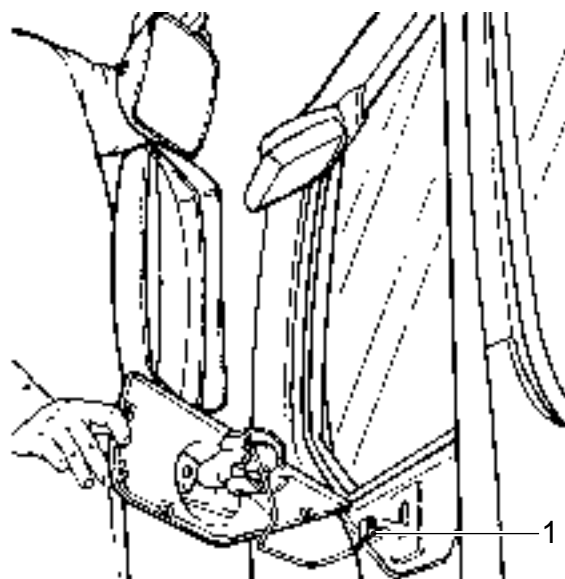

K1 01 172

4.17 REMOVAL AND INSTALLATION, PAVEMENT MIRROR

Removing the pavement mirror

1. Remove the attachment bolts (1) and remove the pavement mirror with the cover plate (2).

Installing the pavement mirror

1. Fit the pavement mirror and the cover plate (2) and secure it with the attachment bolts (1).

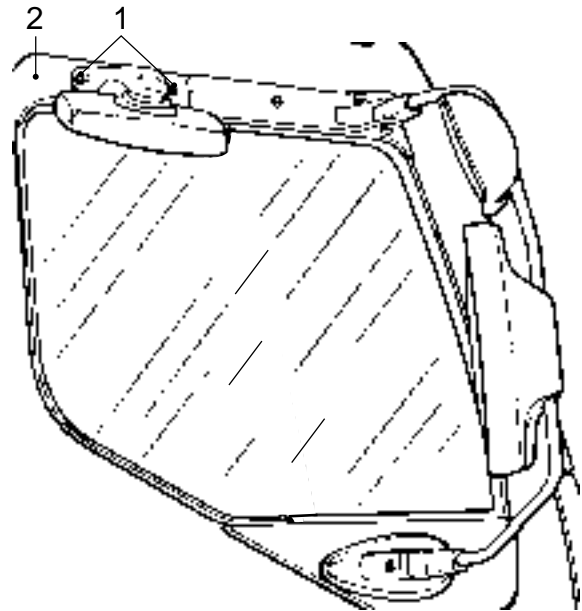

K1 01 173

4.18 REMOVAL AND INSTALLATION, DEAD ANGLE EXTERIOR MIRROR

Removing the dead angle exterior mirror

1. Open the cab grille. Open the co-driver's door.
2. Remove the attachment bolts from the corner piece.
3. Remove the corner piece.
4. Disconnect the dead angle exterior mirror heating connector.
5. Remove the attachment bolts (1) from the dead angle exterior mirror.
6. Remove the dead angle exterior mirror.

Installing the dead angle exterior mirror

1. Fit the dead angle exterior mirror using the attachment bolts (1).
2. Connect the dead angle exterior mirror heating connector.
3. Fit the corner piece using the attachment bolts.

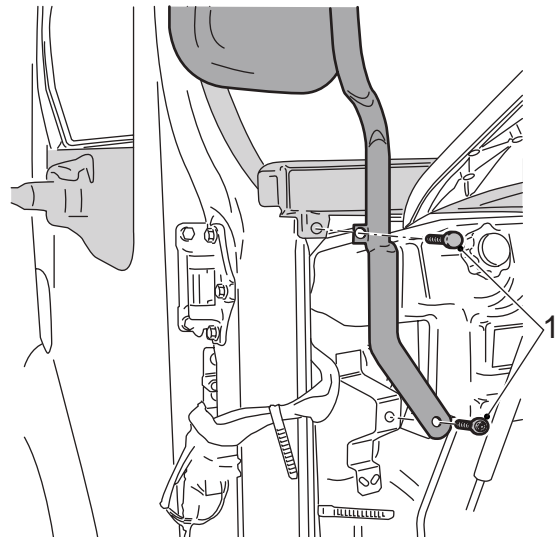

K1 01 423

4.19 REMOVAL AND INSTALLATION, HEADLIGHT

Removing headlight

1. Remove the headlight cover panel.
2. Remove the attachment bolts (1) on the front of the headlight.
3. Pull the headlight forward and disconnect the connectors at the rear.
4. Remove the headlight.

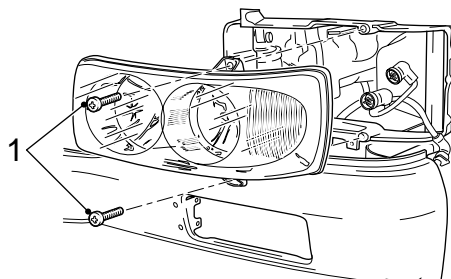

K1 01 183

Installing headlight

1. Connect the headlight.
2. Hook up the rubber bulge in the recess on the headlight bracket.
3. Secure the headlight with the attachment bolts (1) at the front.
4. Fit the headlight cover panel.

4

4.20 REMOVAL AND INSTALLATION, HEADLIGHT BRACKET

Removing headlight bracket

1. Remove the headlight cover panel.
2. Remove the headlight.
3. Remove the attachment bolts.
4. Remove the headlight bracket.

Installing headlight bracket

1. Fit the headlight bracket.
2. Secure the headlight bracket with the attachment bolts.
3. Place the headlight in position.
4. Fit the headlight cover panel.

4.21 REMOVAL AND INSTALLATION, HEADLIGHT LEVELLING CONTROL

Removing headlight levelling control

1. Tilt the cab forwards.
2. Remove the connectors from the headlight levelling control.
3. Remove the headlight levelling control by turning it fully anti-clockwise out of the back of the headlight (at the rear).

Installing headlight levelling control

1. Fit the headlight levelling control by screwing it clockwise into the bayonet catch.
2. Fit the headlight levelling connector.
3. Tilt the cab back.

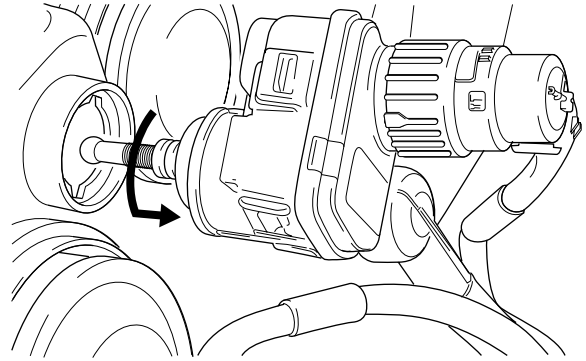

K1 01 100

4

4.22 REMOVAL AND INSTALLATION, MUDGUARD ASSEMBLY

Removing mudguard assembly

1. Tilt the cab forwards.
2. Remove attachment bolts and nuts (1 and 2).
3. Remove the mudguard assembly.

Installing mudguard assembly

1. Fit the mudguard assembly.
2. Fit the attachment bolts (1 and 2).
3. Tilt the cab back.

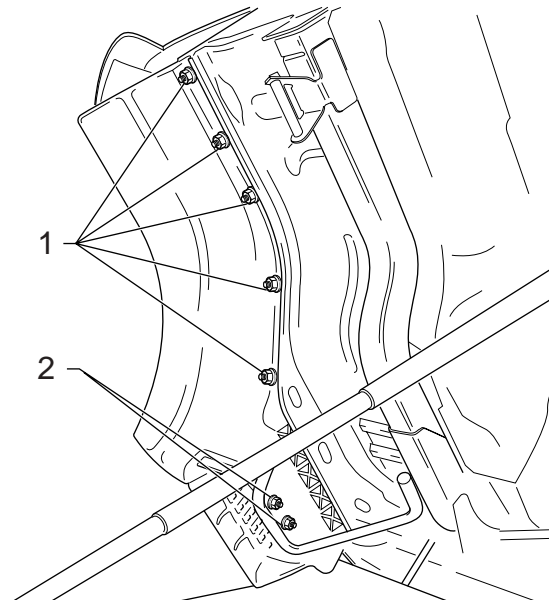

K1 01 158

CONTENTS

	Page	Date
1. SAFETY INSTRUCTIONS	1-1	0210
2. GENERAL	2-1	0210
2.1 Cab suspension	2-1	0210
3. INSPECTION AND ADJUSTMENT	3-1	0210
3.1 Inspection and adjustment, cab height	3-1	0210
4. REMOVAL AND INSTALLATION	4-1	0210
4.1 Removing the cab stabiliser	4-1	0210
4.2 Removal and installation, front spring suspension cab support	4-2	0210
4.3 Removal and installation, cab front rubber suspension support	4-4	0210
4.4 Removal and installation, silent blocks of front spring suspension cab support	4-6	0210
4.5 Removal and installation, silent block of cab front rubber suspension support	4-8	0210
4.6 Removal and installation, coil spring front suspension	4-10	0210
4.7 Removal and installation, rear coil spring suspension	4-11	0210
4.8 Removal and installation, cab locking mechanism	4-12	0210
4.9 Removal and installation, complete cab	4-13	0210

1. SAFETY INSTRUCTIONS

General

The cab is equipped with a hydraulic tilting gear. The pump is located on co-driver's side at the rear of the cab. The cab locks are opened hydraulically during pumping.

Before tilting the cab, make sure that the doors are closed, that there are no loose items in the cab and that the gear lever is in neutral. Tilt the cab fully forward if work is to be carried out underneath the cab.



You can stop the cab tilting forward at any time by turning the cock to the reverse tilting position.



When working on a tilted cab (for example when welding, spray-painting or applying bitumen coatings), be sure to cover the piston rod of the lifting cylinder. Welding spatter and paint on the piston rod will inevitably cause damage to the oil seal.

Inspection after a collision

Before tilting the cab after a collision, check the cab rests, the cab hinges and the attachment of the lifting cylinder to the chassis member and cab for cracks.



If the vehicle has been involved in a collision, the cab must under no circumstances be tilted without due precautions. The end stop in the lifting cylinder may be damaged, which might cause the cab to shoot past its end stop.

If possible, suspend the cab in slings and put a stand in front of the cab. Make sure that there is no one in front of the cab while it is being tilted.

Replacing the lifting cylinder

After a collision, **always** check the lifting cylinder for internal damage.

Replace the lifting cylinder if it is damaged or if you are in doubt as to its condition.

Always replace the cylinder if one of the following points has occurred during a collision:

- A. the cab has been pulled out of the cab locks,
- B. the cab locks have been deformed or damaged,
- C. the rear cab springs have been deformed or damaged.

2. GENERAL

2.1 CAB SUSPENSION

The cab is attached to the chassis at four different points. There are several types of cab suspension.

Rubber and spring suspension.

All models use springs for rear suspension. Both rubber and spring suspension are used at the front. If the vehicle uses rubber suspension at the front, a cab stabiliser is not fitted.

Spring suspension

The cab is attached to the chassis with front and rear coil spring elements. These elements cannot be adjusted. There is a cab stabiliser at the front.



Do not tilt the cab if the stabiliser has been removed.

3. INSPECTION AND ADJUSTMENT

3.1 INSPECTION AND ADJUSTMENT, CAB HEIGHT

Checking the cab height

If the vehicle has spring suspension, it is possible to make some adjustment in cab height.

Setting the cab height

1. Check the height on the left and right sides.
2. Slacken the attachment bolts on the stabiliser.
3. Place a weight in the cab in order to correct the height difference.
4. Tighten the stabiliser attachment bolts.

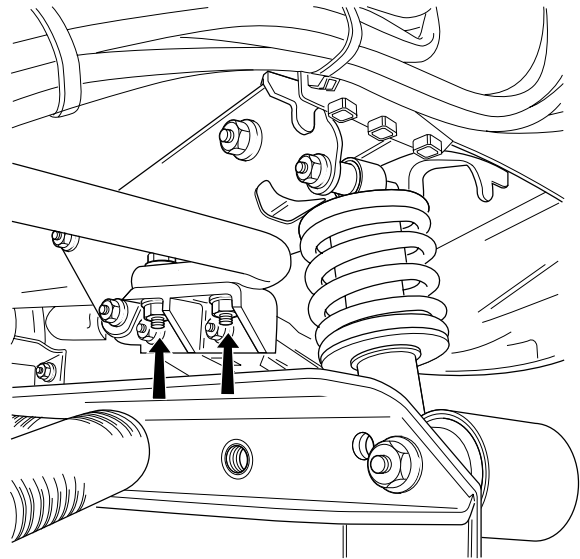

K1 01 161

4. REMOVAL AND INSTALLATION

4.1 REMOVING THE CAB STABILISER

Removing the cab stabiliser

Note:

If the cab has spring suspension, do not tilt the cab without the cab stabiliser.

1. Open the grille.
2. Remove the cab stabiliser attachment bolts.
3. Remove the cab stabiliser.

Installing the cab stabiliser

1. Put the cab stabiliser in place.
2. Tighten the attachment bolts.
3. Inspect the cab for correct alignment, see "Inspection and adjustment".

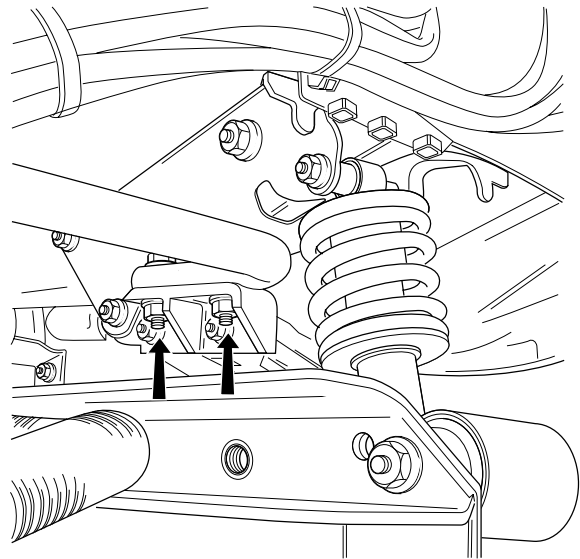

K1 01 161

4.2 REMOVAL AND INSTALLATION, FRONT SPRING SUSPENSION CAB SUPPORT

Removing the cab support



Only use approved lifting equipment.
Comply with general safety instructions when working with lifting equipment.

1. Suspend the cab from the hoisting belt.

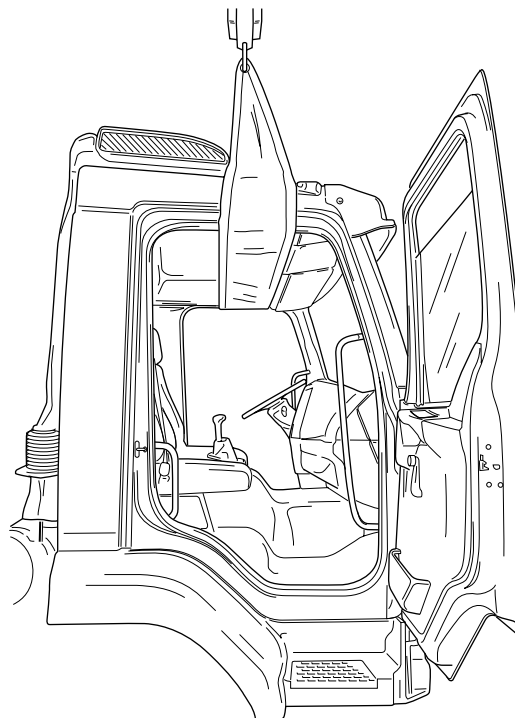

K1 01 212

2. Place a block under the entrance step support on the side where the cab support will be removed.
3. Remove the headlight cover panel.

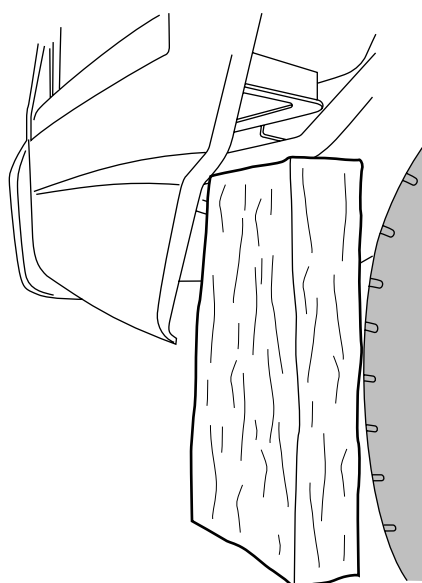

K1 01 198

1

LF45/55 series

CAB SUSPENSION

Removal and installation

4. Remove the attachment bolt (1).
5. Remove the cab stabiliser attachment bolts (2).
6. Remove the attachment bolt (3).
7. Remove the suspension attachment bolt (4).
8. Remove the cab support.

Installing the cab support

1. Fit the support.
2. Check the distance between the cab supports, see "Technical data".
3. Fit the attachment bolts (1) and (3) hand-tighten them with the bolt heads on the inside. Fit the attachment bolts (2) with the bolt heads facing upwards. Fit the attachment bolt (4) with the bolt head on the outer side.
4. Remove the block.
5. Lower the cab and secure the attachment bolt (3). Tighten the attachment bolt (1) to the specified torque. See "Technical data".
6. Remove the hoisting belt.
7. Inspect the cab for correct alignment, see "Inspection and adjustment".
8. Fit the headlight cover panel.

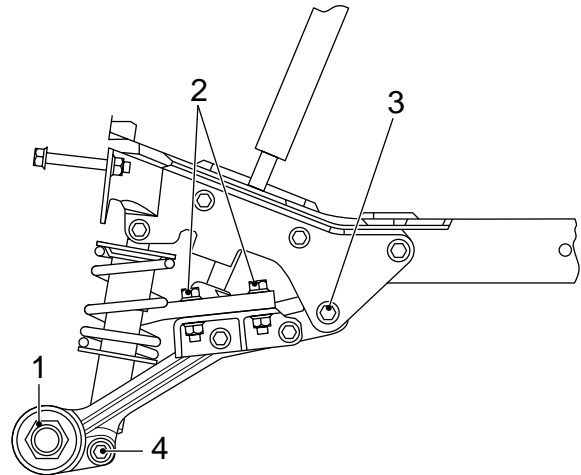

K1 01 204

4.3 REMOVAL AND INSTALLATION, CAB FRONT RUBBER SUSPENSION SUPPORT

Removing the cab support



Only use approved lifting equipment.
Comply with general safety instructions when working with lifting equipment.

1. Suspend the cab from the hoisting belt.

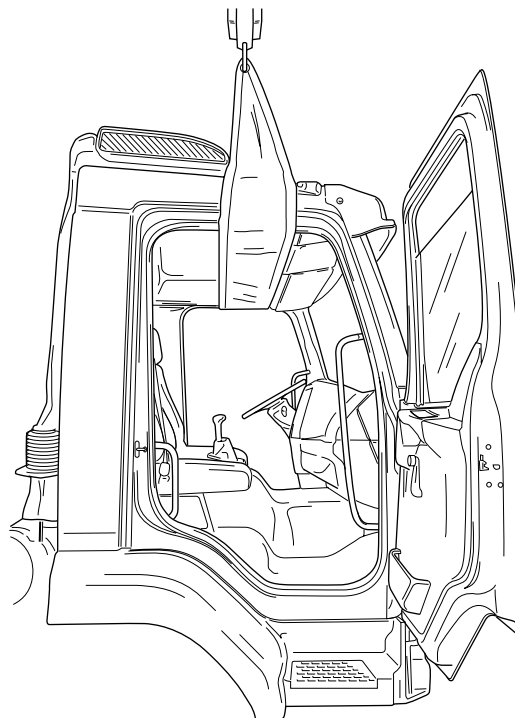

K1 01 212

2. Place a block under the entrance step support on the side where the cab support will be removed.
3. Remove the headlight cover panel.

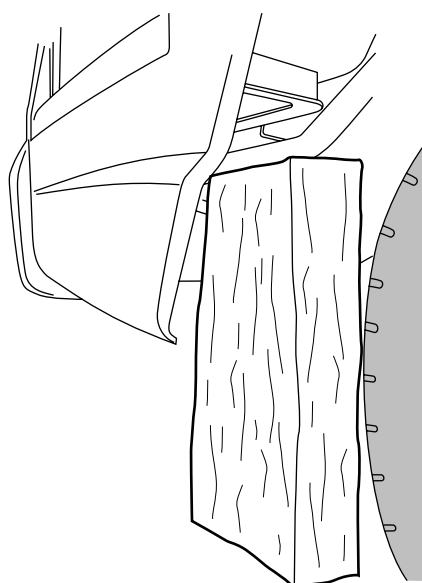

K1 01 198

1

LF45/55 series

CAB SUSPENSION

Removal and installation

4. Remove the attachment bolt (3).
5. Remove the attachment bolts (4).
6. Remove the cab support.

Installing the cab support

1. Fit the support with the attachment bolts (4), with the bolt heads facing downwards.
2. Check the distance between the cab supports, see "Technical data".
3. Tighten the attachment bolts (4).
4. Remove the block.
5. Lower the cab, tighten the attachment bolt (3) with the bolt head on the outer side to the specified torque, see "Technical data".
6. Remove the hoisting belt.
7. Inspect the cab for correct alignment, see "Inspection and adjustment".
8. Fit the headlight cover panel.

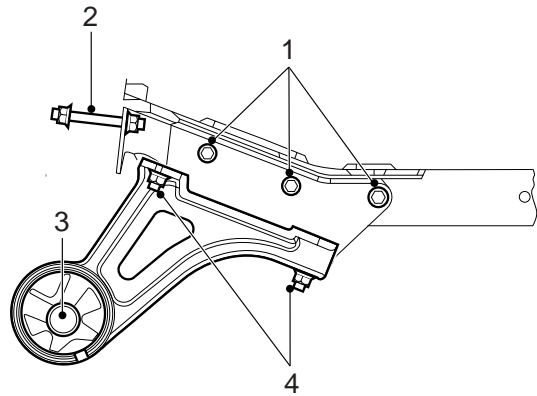

K1 01 476

4.4 REMOVAL AND INSTALLATION, SILENT BLOCKS OF FRONT SPRING SUSPENSION CAB SUPPORT

Note:

To remove and install the silent blocks, use special tool (DAF no. 1329471).

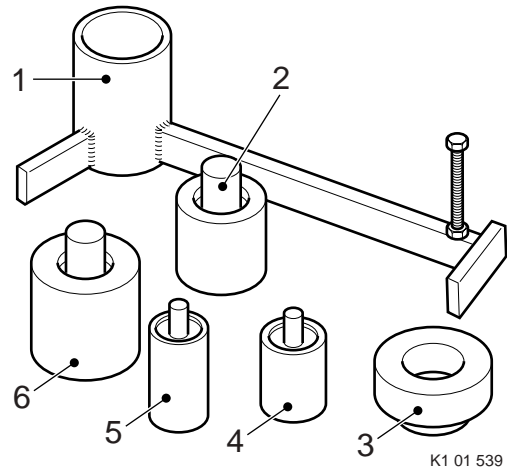

Removing the front silent block

1. Place the housing of the cab support on the base (1) of the special tool (DAF no. 1329471).
2. Force the front silent block (1) out of the housing using the press-out tool (2) of the special tool (DAF no. 1329471).

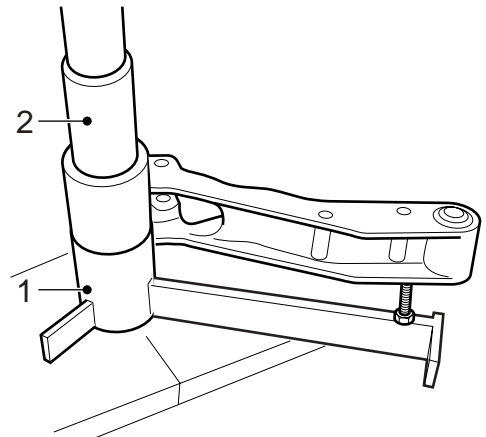

Removing the rear silent block

1. Place the back-up washer (3) of the special tool (DAF no. 1329471) on the base (1).
2. Place the housing of the cab support on the base (1) with the back-up washer (3).
3. Force the rear silent block out of the housing using the press-out tool (5) of the special tool (DAF no. 1329471).

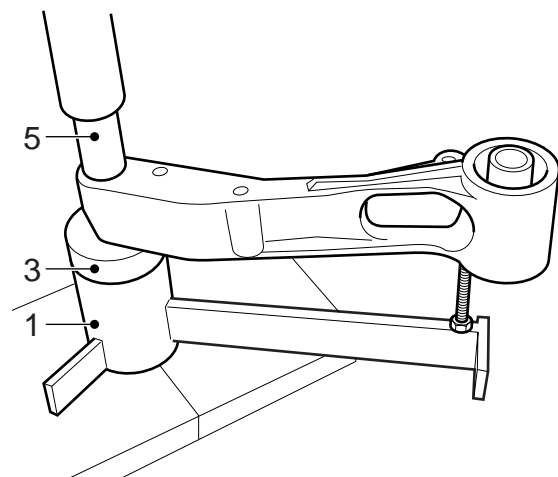

Installing the front silent block

1. Place the housing of the cab support on the base (1).

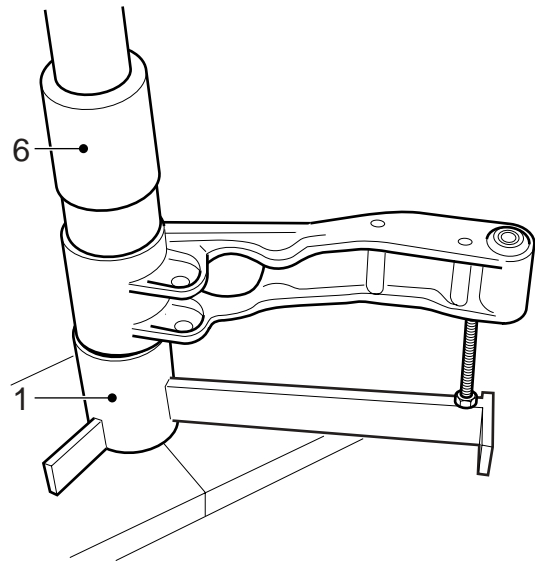

K1 01 537

2. Place the silent block, its openings in the right positions (angle A), on the housing of the cab support, see "Technical data".

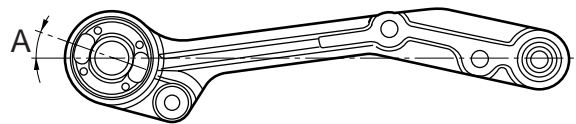

K1 01 442

3. Force the silent block into the housing using the press-in tool (6) of the special tool (DAF no. 1329471).

Installing the rear silent block

1. Place the back-up washer (3) on the base (1).
2. Place the housing of the cab support on the base (1) with the back-up washer (3).
3. Force the silent block into the housing using the press-in tool (4) of the special tool (DAF no. 1329471).

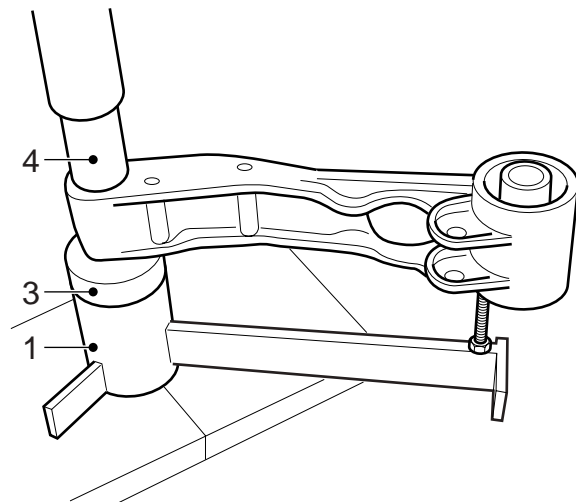

K1 01 536

4.5 REMOVAL AND INSTALLATION, SILENT BLOCK OF CAB FRONT RUBBER SUSPENSION SUPPORT

Note:

To remove and install the silent block, use special tool (DAF no. 1453126).

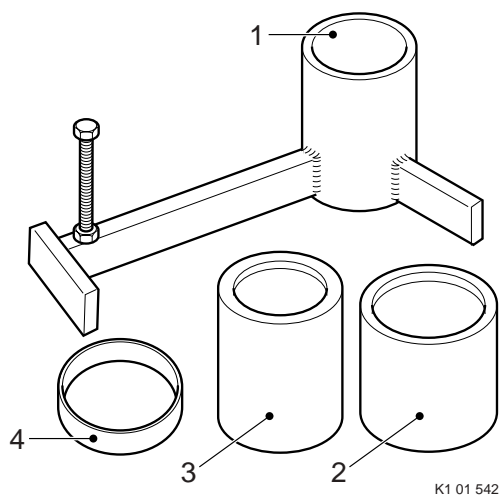

5

Removing the silent block

1. Place the housing of the cab support on the base (1) of the special tool (DAF no. 1453126).
2. Place the guide ring (4) of the special tool (DAF no. 1453126) over the edge of the silent block.
3. Force the silent block out of the housing using the press-out tool (3) of the special tool (DAF no. 1453126).

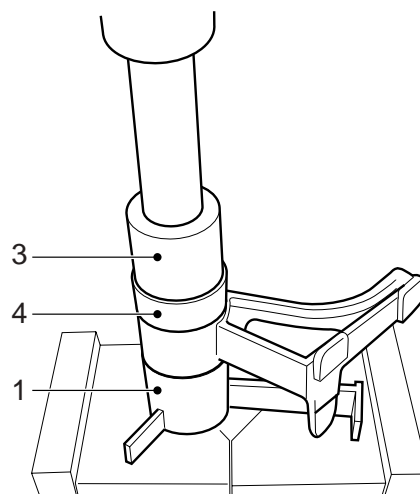

Installing the silent block

1. Place the housing of the cab support on the base (1).

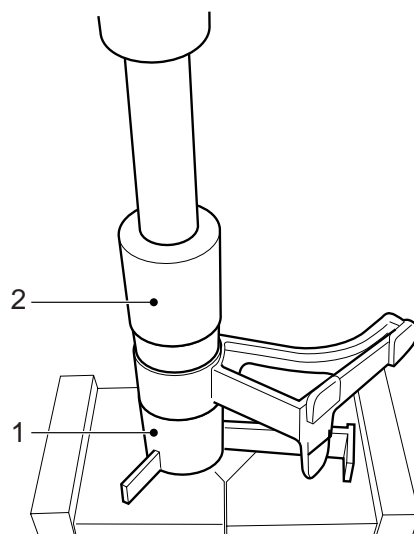

1

LF45/55 series

CAB SUSPENSION

Removal and installation

2. Place the silent block, its openings in the right positions (angle A), on the housing of the cab support, see "Technical data".

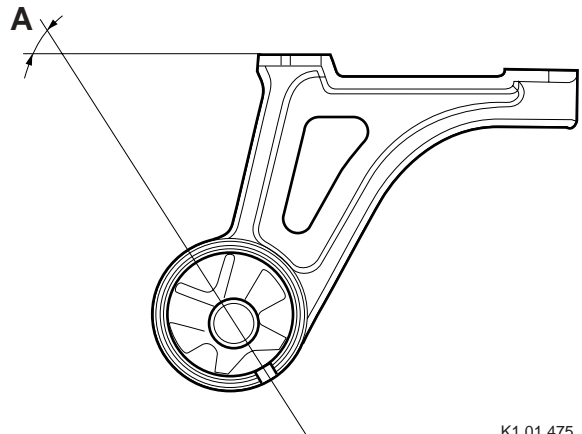

K1 01 475

3. Force the silent block into the housing using the press-in tool (2) of the special tool (DAF no. 1453126).

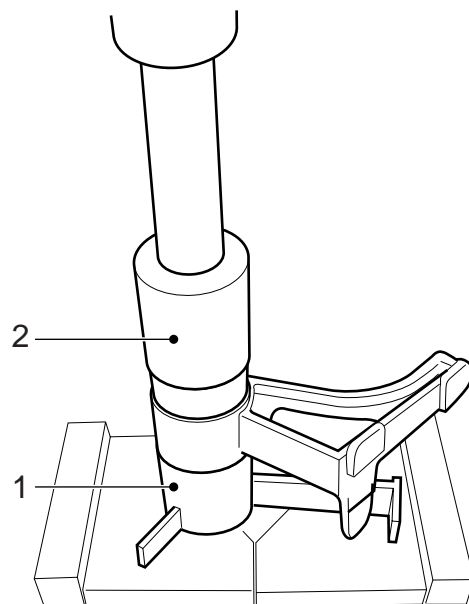

K1 01 543

5

4.6 REMOVAL AND INSTALLATION, COIL SPRING FRONT SUSPENSION

Removing front spring suspension



Only use approved lifting equipment.
Comply with general safety instructions when working with lifting equipment.

1. Suspend the cab from the hoisting belt.

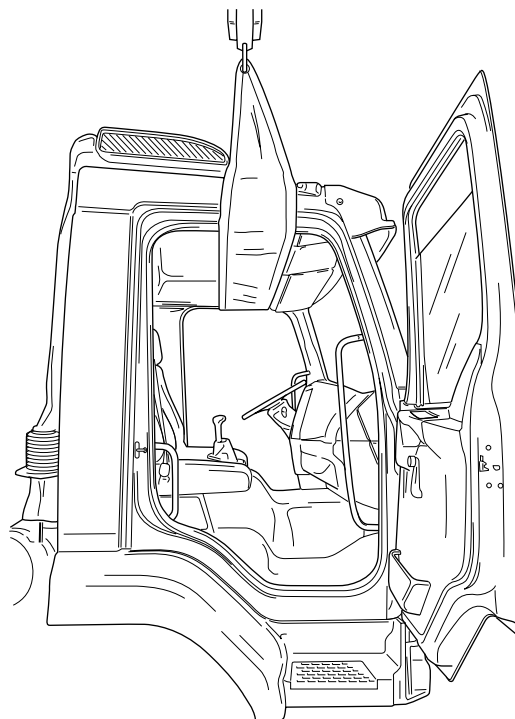

K1 01 212

2. Place a block under the entrance step support on the side where the cab support will be removed.
3. Remove the headlight cover panel.

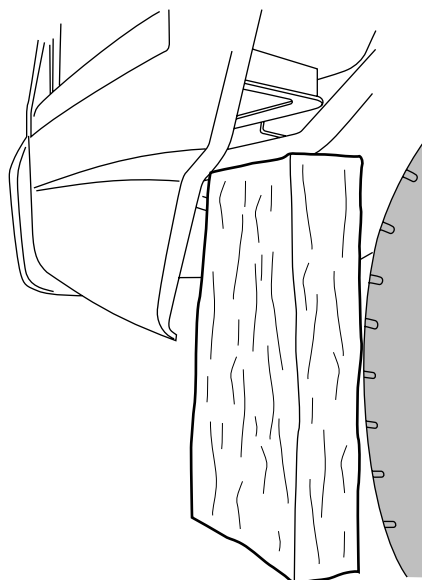

K1 01 198

4. Remove the attachment bolts (1) and (2).
5. Remove the coil spring element.

Installing front spring suspension

1. Put the spring element in place.
2. Fit the attachment bolt (1) in the cab support with the bolt head on the inside.
3. Fit the attachment bolt (2) in the chassis support with the bolt head on the outer side.
4. Remove the hoisting belt.
5. Fit the headlight cover panel and secure it with the attachment bolts.

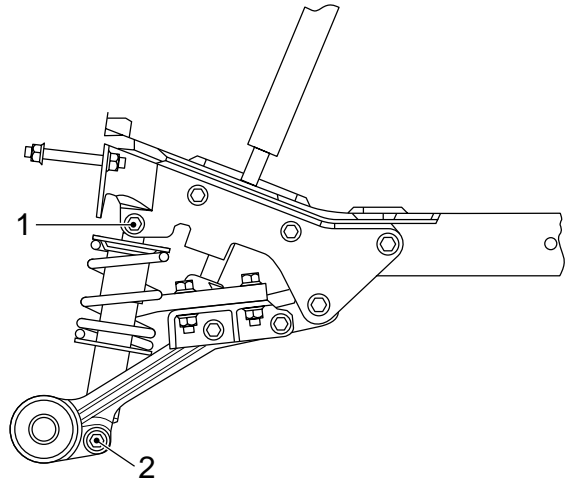

K1 01 205

4.7 REMOVAL AND INSTALLATION, REAR COIL SPRING SUSPENSION

Removing rear coil spring suspension

1. Tilt the cab forward.
2. Remove the attachment bolt (1) at the top of the spring element.
3. Remove the attachment bolt and nut (2) at the top.
4. Remove the spring element.

Installing rear coil spring suspension

1. Put the spring element in place.
2. Hand-tighten the attachment bolt (1).
3. Fit the attachment bolt and nut (2) and hand-tighten them.
4. Tilt the cab back.
5. Tighten the attachment bolts and nuts (1), (2).

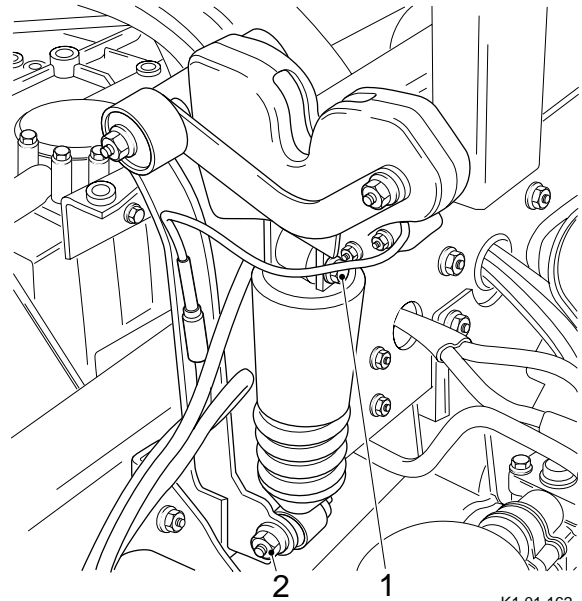

K1 01 162

4.8 REMOVAL AND INSTALLATION, CAB LOCKING MECHANISM

Removing cab locking mechanism

1. Tilt the cab until it is released from the cab lock.
2. Support the cab using a hoist or place a block or support underneath.
3. Switch the tilting pump to reverse tilting.
4. Remove the proximity switch connector at the right-hand side.
5. Remove the hydraulic line (quick-release coupling).
6. Remove the attachment bolts (2 and 3).
7. Remove the cab lock (1).

Installing cab lock mechanism

1. Fit the cab-locking mechanism (1).
2. Fit the attachment bolts (2 and 3) and hand-tighten them.
3. Connect the hydraulic line.
4. Fit the connector of the cab tilting switch.
5. Carefully lower the cab. When doing so, ensure that the locks are open.
6. Tighten the attachment bolts (2 and 3).

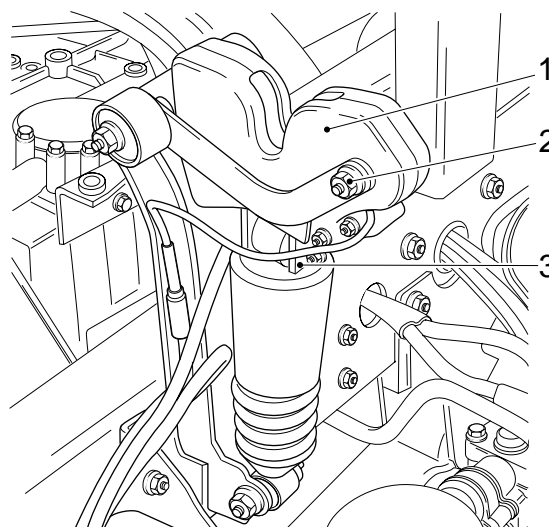

K1 01 203

4.9 REMOVAL AND INSTALLATION, COMPLETE CAB

Removing complete cab



**Only use approved lifting equipment.
Comply with general safety instructions when working with lifting equipment.**

1. Disconnect the earth lead from the battery terminal.

Note:

Work on the air conditioning unit should only be carried out by qualified personnel.

2. If applicable, drain the air conditioning unit.
3. Drain the cooling water. Remove cooling water pipes.
4. Tilt the cab forward. Remove the spring clip from the selector rod. Pull the selector rod apart.
5. Tilt the cab back and place wood blocks under the cab, so that it does not go into the locked position.

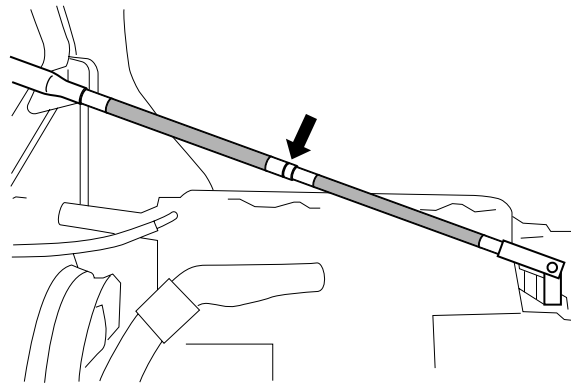

K1 01 213

6. Fit the hoisting belt to support the cab.

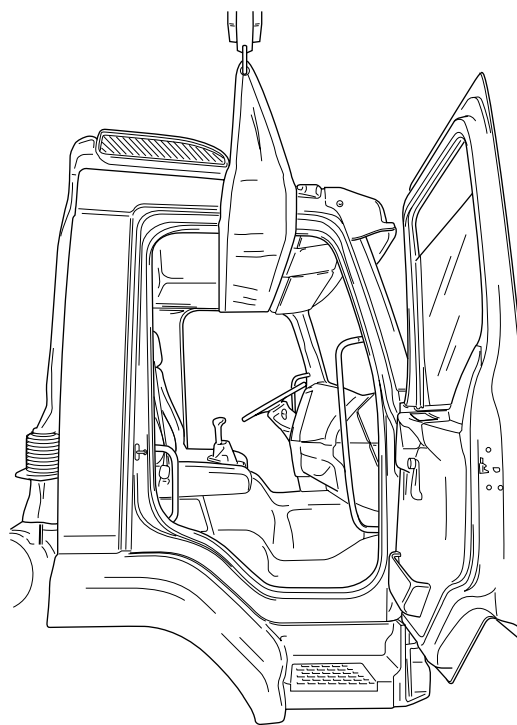

K1 01 212

7. Remove the cover from the cab lead-through and remove the positive cable (2).
8. Remove the connectors (1).
9. Remove the wiring harness attachment.
10. Remove the air pipes from the cab lead-through.

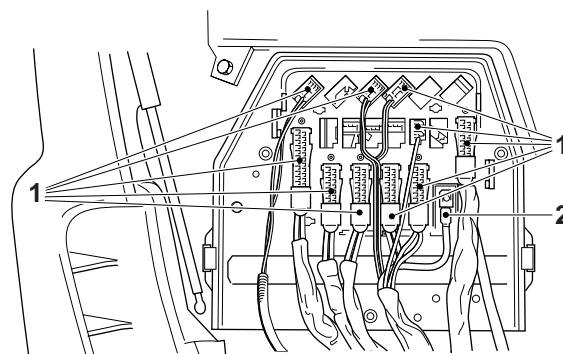

GO 00 203

11. Disconnect the air pipes (2) from the service brake valve.
12. Remove the clutch cylinder pipe (3). Collect the clutch fluid.
13. Remove the earth lead (1).
14. Remove the (air) pipe attachment.
15. Remove the lifting cylinder pin.

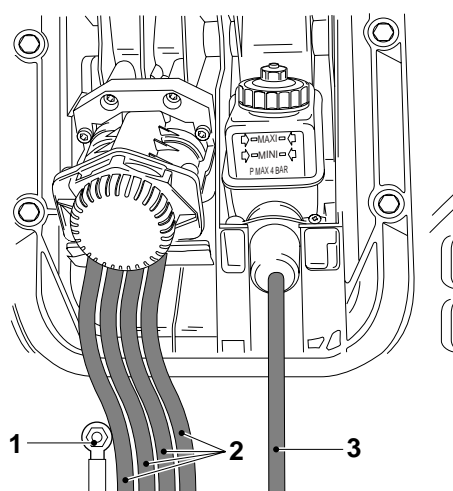

K1 01 214

16. Hoist the cab a little way and remove the attachment bolts at the front.
17. Remove the complete cab.

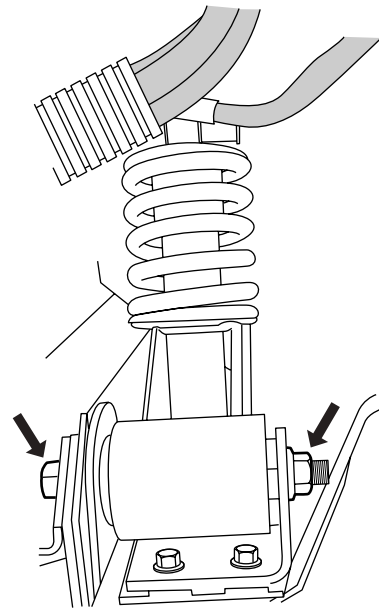

K1 01 218

Installing complete cab

1. Install the cab.
2. Fit the attachment bolts at the front.
3. Fit the lifting cylinder pin.
4. Connect the air pipes to the cab lead-through.
5. Fit the connectors (1). Fit the positive cable (2).

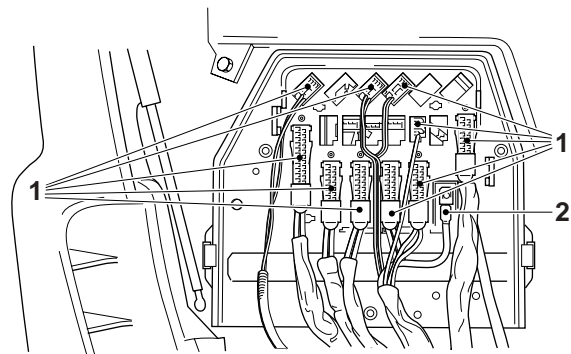

G0 00 203

6. Fit the pipes (2) to the service brake valve. Secure the clutch cylinder (3) pipe with the retaining clip. Bleed the clutch cylinder.
7. Fit the earth lead (1).

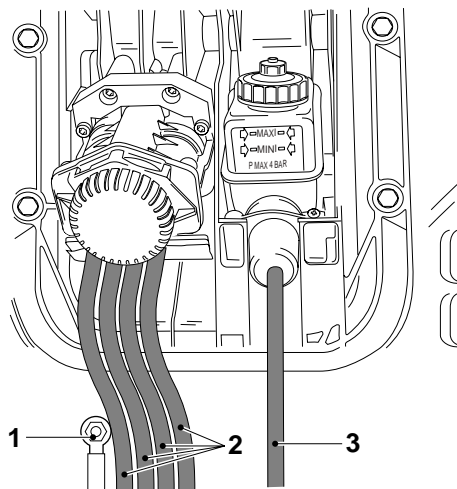

K1 01 214

5

8. Secure pipes with clamping strips to prevent chafing and pipes being worn through.
9. Remove the hoisting belt.
10. Tilt the cab forward.
11. Re-connect the selector rod and fit the spring clip in the selector rod.

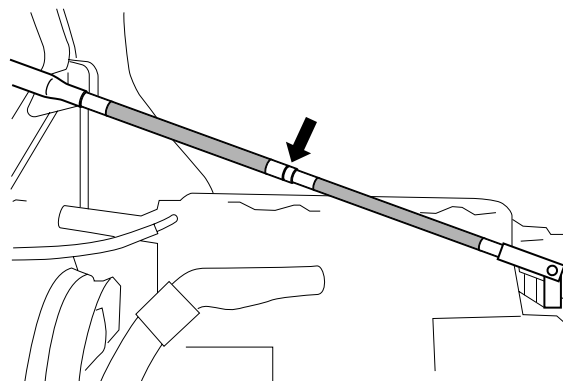

K1 01 213

12. Fit the coolant hoses. Fill the cooling system.
13. Fill the air conditioning unit, if necessary..
14. Fit the earth lead to the battery terminal.

CONTENTS

	Page	Date
1. SAFETY INSTRUCTIONS	1-1	0210
2. GENERAL	2-1	0210
2.1 System description, cab tilting mechanism	2-1	0210
2.2 Overview drawing, cab tilting pump	2-2	0210
2.3 Overview drawing, lifting cylinder	2-3	0210
3. INSPECTION AND ADJUSTMENT	3-1	0210
3.1 Checking cab-tilting pump	3-1	0210
4. REMOVAL AND INSTALLATION	4-1	0210
4.1 Removal and installation, lifting cylinder	4-1	0210
4.2 Removal and installation, cab tilting pump	4-2	0210
5. DISASSEMBLY AND ASSEMBLY	5-1	0210
5.1 Disassembly and assembly, cab tilting pump	5-1	0210
6. DRAINING AND FILLING	6-1	0210
6.1 Filling and bleeding, tilting mechanism	6-1	0210

1. SAFETY INSTRUCTIONS

General

The cab is equipped with a hydraulic tilting gear. The pump is located on co-driver's side at the rear of the cab. The cab locks are opened hydraulically during pumping.

Before tilting the cab, make sure that the doors are closed, that there are no loose items in the cab and that the gear lever is in neutral. Tilt the cab fully forward if work is to be carried out underneath the cab.



You can stop the cab tilting forward at any time by turning the cock to the reverse tilting position.



When working on a tilted cab (for example when welding, spray-painting or applying bitumen coatings), be sure to cover the piston rod of the lifting cylinder. Welding spatter and paint on the piston rod will inevitably cause damage to the oil seal.

Inspection after a collision

Before tilting the cab after a collision, check the cab rests, the cab hinges and the attachment of the lifting cylinder to the chassis member and cab for cracks.



If the vehicle has been involved in a collision, the cab must under no circumstances be tilted without due precautions. The end stop in the lifting cylinder may be damaged, which might cause the cab to shoot past its end stop.

If possible, suspend the cab in slings and put a stand in front of the cab. Make sure that there is no one in front of the cab while it is being tilted.

Replacing the lifting cylinder

After a collision, **always** check the lifting cylinder for internal damage.

Replace the lifting cylinder if it is damaged or if you are in doubt as to its condition.

Always replace the cylinder if one of the following points has occurred during a collision:

- A. the cab has been pulled out of the cab locks,
- B. the cab locks have been deformed or damaged,
- C. the rear cab springs have been deformed or damaged.

2. GENERAL

2.1 SYSTEM DESCRIPTION, CAB TILTING MECHANISM

General

The cab is equipped with a hydraulic tilting gear. The pump is on co-driver side behind the stepwell.

The cab locks are automatically released during pumping.

The hydraulic locking mechanism has a switch on one side, to activate the warning light for tilted cab (in the instrument panel).

If the vehicle has been involved in a collision, check the following points before tilting the cab.

- cab rests,
- cab hinges,
- attachment of the lifting cylinder,
- hydraulic system for leakage.

After this check, continue to proceed with utmost care.

If possible, suspend the cab in slings and put a stand in front of the cab.

After a collision, always check the lifting cylinder for internal damage.

Tilting the cab:

- Make sure there are no people immediately in front of the cab.
- Make sure there is sufficient clearance around the cab.
- Make sure there are no loose objects inside the cab.
- Apply the parking brake.
- Move the gear lever to the right position and turn off the engine.
- Close the doors.
- Turn the cab-tilting pump cock as far to the right as possible.
- Position the rod in the pump and operate the pump.

You can stop the cab tilting forward at any time by turning the cock anticlockwise.

2.2 OVERVIEW DRAWING, CAB TILTING PUMP

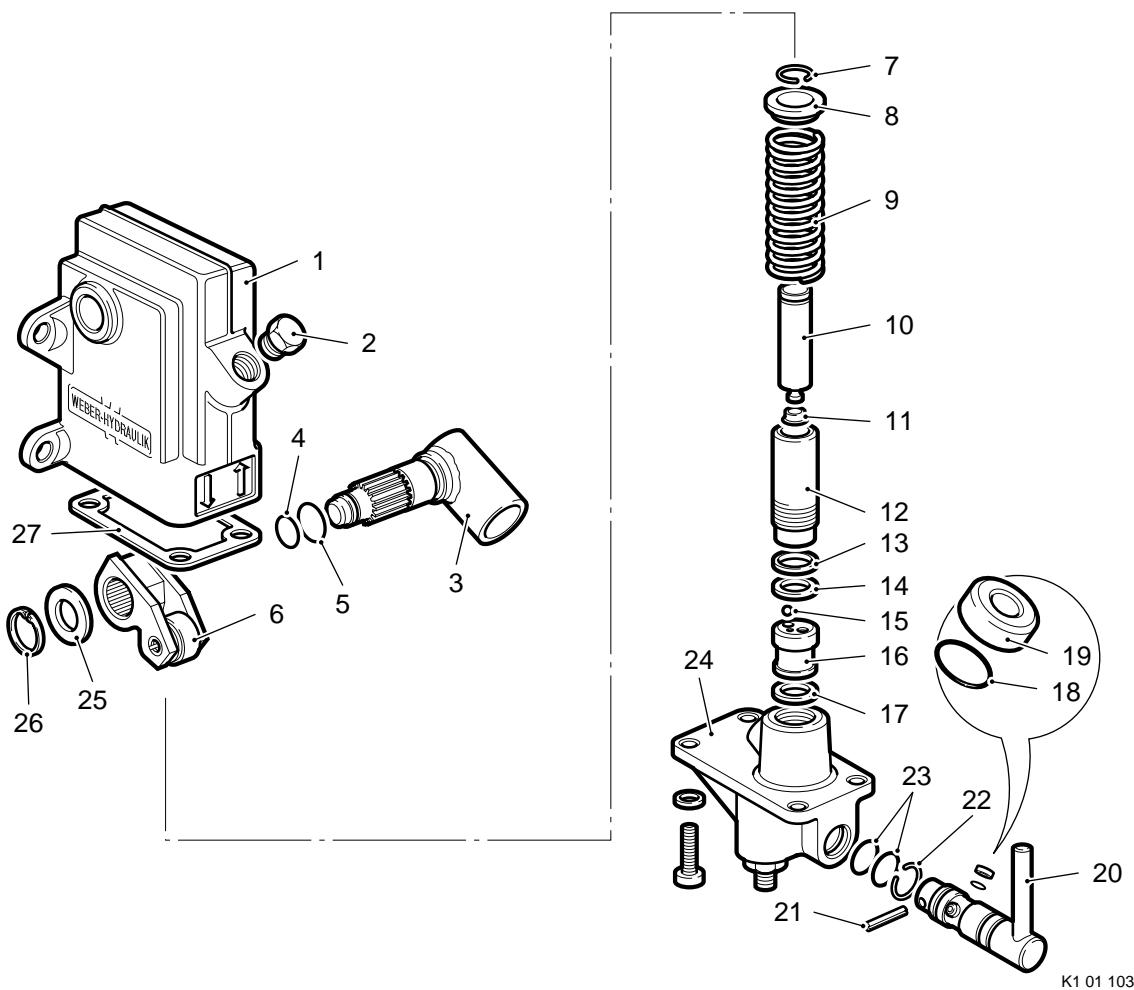

K1 01 103

Legend

- | | |
|---------------------|------------------------|
| 1. Reservoir | 15. Ball |
| 2. Filler plug | 16. Valve block |
| 3. Lever block | 17. Copper washer |
| 4. O-ring | 18. O-ring |
| 5. O-ring | 19. Seal |
| 6. Cam | 20. Direction selector |
| 7. Circlip | 21. Pin |
| 8. Washer | 22. Circlip |
| 9. Spring | 23. O-ring |
| 10. Plunger | 24. Pump housing |
| 11. Grooved ring | 25. Spacer |
| 12. Plunger housing | 26. Spring washer |
| 13. Seal | 27. Gasket |
| 14. Copper washer | |

2.3 OVERVIEW DRAWING, LIFTING CYLINDER

Legend

1. Split pin
2. Dowel pin
3. Lifting cylinder
4. Washer
5. Bottom attachment nut
6. Hydraulic lines

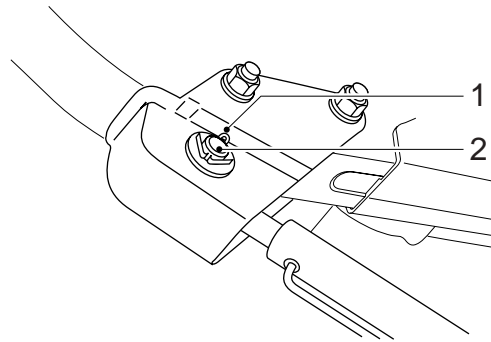

K1 01 220

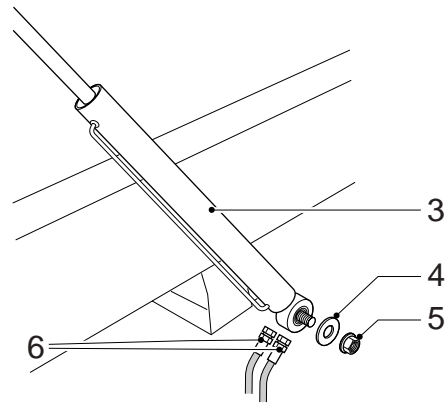

K1 01 222

3. INSPECTION AND ADJUSTMENT

3.1 CHECKING CAB-TILTING PUMP

Checking cab-tilting pump

1. Check all hoses and connections for any leakage.
2. Disconnect the hoses from the pump and close off the connections to the pump.
3. Check the oil level in the pump.
4. Place the switch cock in the "lowering" position, apply a few pump strokes and check whether the pressure-relief valve is activated. Then place the switch cock in the "lifting" position and check the operation of the pressure-relief valve again.
5. Inspect the pump plunger for any leakage.

If the above checks of the pump are unsuccessful, the lifting cylinder is defective. A defective pump is often the result of contaminated hydraulic oil.

4. REMOVAL AND INSTALLATION

4.1 REMOVAL AND INSTALLATION, LIFTING CYLINDER

Removing lifting cylinder

Notes:

Do **not** remove the lifting cylinder while the cab is in the tilted position.

Mark the piping before removing it.

1. Remove all dirt and grease in the cylinder.
2. Place an appropriate receptacle under the pump, loosen the hydraulic pipes (6) and plug the ends to prevent dirt getting in.
3. Remove the split pin (1) from the cab support pin. Remove the pin (2).

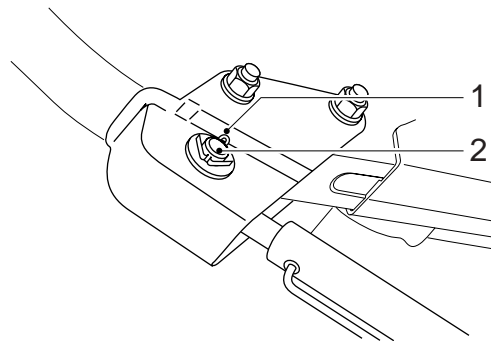

K1 01 220

4. Remove the nut and washer (4 and 5).
5. Remove the lifting cylinder (3).

Installing lifting cylinder

1. Fit the lifting cylinder (3).
2. Fit the washer and nut (4 and 5) to the underside.
3. Position the lifting cylinder. Fit the pin (2) with the split pin (1) to the cab support.
4. Connect the pipes (6). Bleed the cylinder, see "Draining and filling".

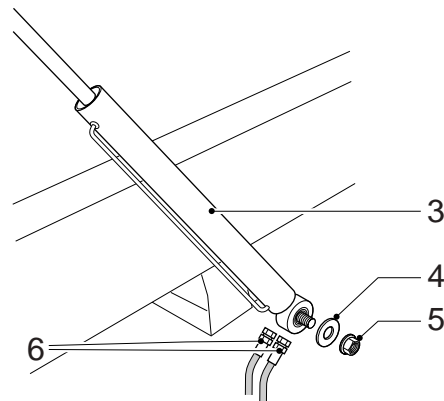

K1 01 101

4.2 REMOVAL AND INSTALLATION, CAB TILTING PUMP**Removing cab tilting pump**

1. Remove all dirt and grease from the pump.
2. Place a receptacle beneath the pump to capture any escaping fluid.
3. Mark the pipes and take them out of the pump holder, plug the ends of the pipes to prevent dirt getting in.
4. Remove the nuts and attachment bolts that connect the pump to the chassis bracket, and remove the pump.

Installing cab tilting pump

1. Install the cab tilting pump. Secure the cab tilting pump with the attachment bolts.
2. Fit the pipes.
3. For filling (1) and bleeding, see "Draining and filling".

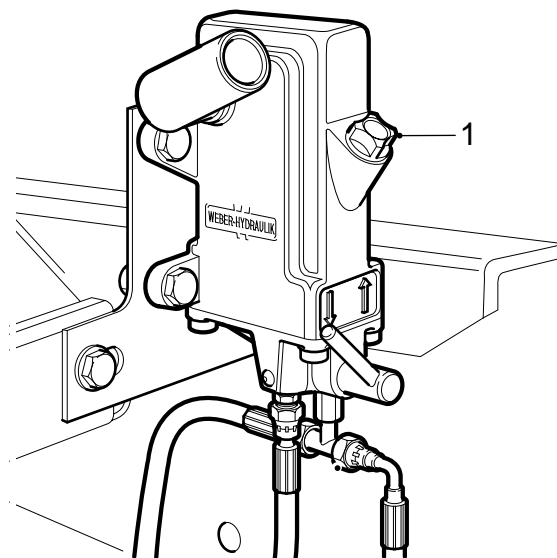

K1 01 105

5. DISASSEMBLY AND ASSEMBLY

5.1 DISASSEMBLY AND ASSEMBLY, CAB TILTING PUMP

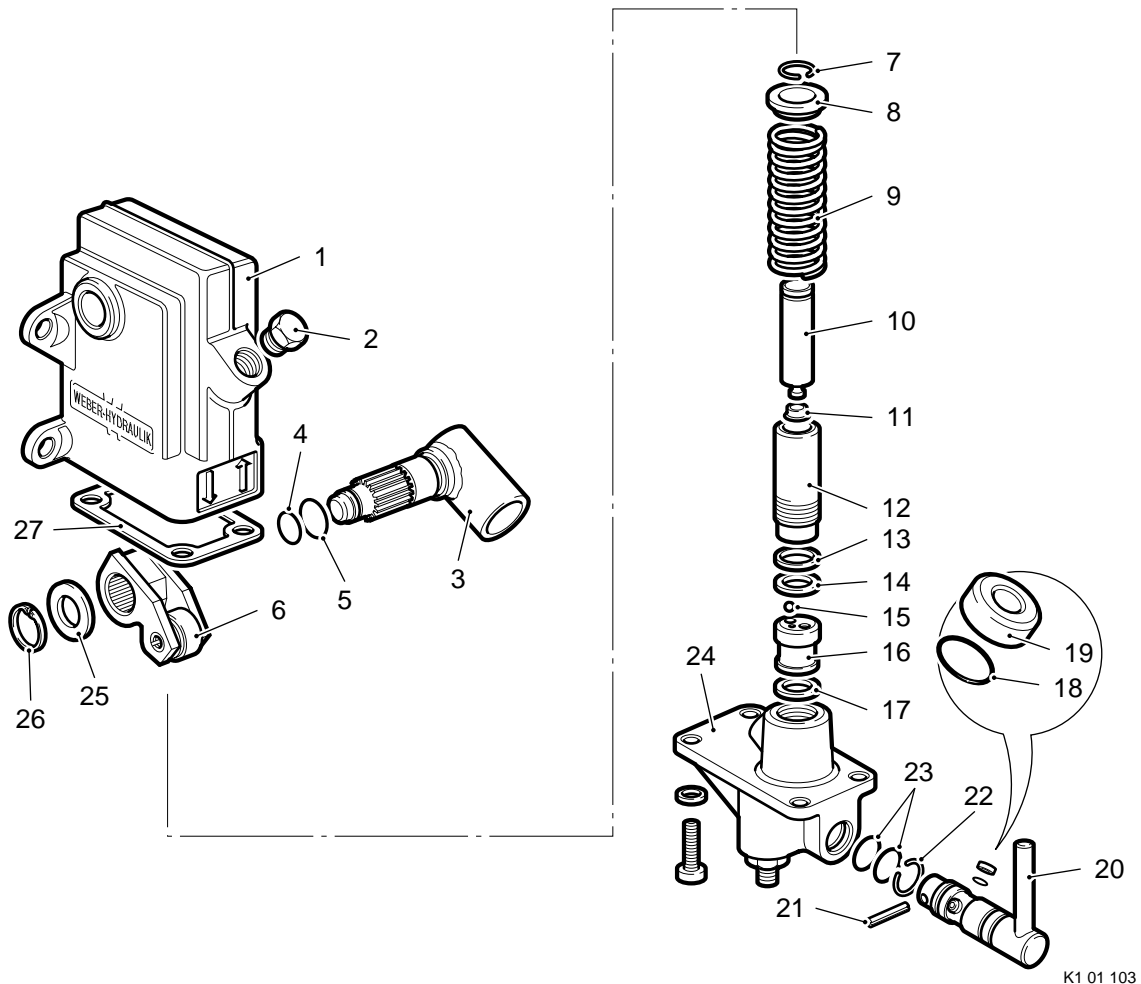
**Disassembling cab tilting pump**

1. Remove the pump, see "Removal and installation".
2. Remove the socket head screws and take the pump housing (24) out of the reservoir (1). Take account of the fact that the pump housing is spring-loaded.
3. Remove the gasket (27).
4. Take the circlip (7), plunger (10), grooved ring (11), spring washer (8) and the spring itself out of the plunger housing (12).

5. Turn the plunger housing (12) off the pump housing (24) and remove the seal (13) and the copper washer (14).
6. Push the valve block (16) out of the pump housing and pay attention to the ball (15).
7. Remove the copper washer (17).

Note:

The valve block (16) is a sealed unit with a pressure-relief valve inside that is set by the manufacturer and cannot be taken apart.

8. Tap the pin (21), which attaches the cross bar and within it the direction selector (20), until it is loose and take the cross bar carefully off the housing. Pay attention to the O-rings (18) and (23) and seal (19).
9. Remove the spring washer (26) and the spacer (25) that secure the lever block (3).
10. Remove the lever block (3) and the cam (6) of the reservoir (1). Pay attention to the O-rings (4) and (5).

Assembling cab tilting pump

1. Check and the O-rings (4) and (5) and replace them if necessary. Fit the lever block (3) and the cam (6) with O-rings (4) and (5) in the reservoir (1).
2. Fit the spacer (25) and the spring washer (26) to the lever block (3).
3. Check the O- rings (18) and (23) and the seal (19). Replace them if necessary.
4. Fit the O- rings (18) and (23) and the seal (19) to the direction selector (20). Fit the direction selector (20) into the pump housing (24).
5. Fit the pin (21).
6. Place the copper washer (17) on the pump housing (24) and fit the valve block (16). Pay attention to the ball (15).

7. Check seal (13) and replace if necessary.
8. Turn the plunger housing (12) with the seal (13) and copper washer (14) in the pump housing (24).

Note:

The bevelled side of the seal (13) points in the direction of the plunger housing (12).

9. Fit the grooved ring (11) and the plunger (10) in the plunger housing (12).
10. Fit the spring (9), the spring washer (8) and the circlip (7).
11. Fit a new gasket to the pump housing (24).
12. Fit the pump housing (24) in the reservoir (1) in line with the marks.
13. Tighten the socket head screws.

6. DRAINING AND FILLING

6.1 FILLING AND BLEEDING, TILTING MECHANISM

Filling and bleeding, cab tilting mechanism

Note:

The cab tilting pump and lifting cylinder are self-bleeding.

The cab must be tilted completely back.

Check whether the lifting components have been fitted correctly and whether the connected piping is secure enough.

1. Fill the reservoir to the maximum level, see fluids and lubricants specifications.
2. Put the pump in the forward tilting position.
3. Tilt the cab completely forward.
4. Tilt the cab all the way back.
5. Remove the filler plug and top up the oil.
6. Repeat this process three times to bleed the whole system.
7. Fit the filler plug.

CONTENTS

	Page	Date
1. SAFETY INSTRUCTIONS	1-1	0210
2. GENERAL	2-1	0210
2.1 Operation	2-1	0210
2.2 Serial/type plate of seat	2-2	0210
2.3 System description, air-sprung seat	2-3	0210
2.4 Overview drawing, air-sprung seat	2-5	0210
2.5 Operation, gas-sprung seat	2-6	0210
2.6 Overview drawing, gas-sprung seat	2-7	0210
3. INSPECTION AND ADJUSTMENT	3-1	0210
3.1 Inspection, seat belt operation	3-1	0210
3.2 Adjusting the control cable of the height control valve	3-1	0210
4. REMOVAL AND INSTALLATION	4-1	0210
4.1 Removal and installation, seat assembly	4-1	0210
4.2 Removal and installation, seat slide	4-2	0210
4.3 Removal and installation, seat adjusting mechanism	4-2	0210
4.4 Removal and installation, seat squab	4-3	0210
4.5 Removal and installation, seat squab guide	4-4	0210
4.6 Removal and installation, front cover panel	4-4	0210
4.7 Removal and installation, rear cover panel	4-4	0210
4.8 Removal and installation, cover panel on control side	4-5	0210
4.9 Removal and installation, cover panel on non-control side	4-7	0210
4.10 Removal and installation, dust boot	4-8	0210
4.11 Removal and installation, seat belt guide panel	4-9	0210
4.12 Removal and installation, backrest	4-9	0210
4.13 Removal and installation, arm rest	4-11	0210
4.14 Removal and installation, seat belt mechanism	4-11	0210
4.15 Removal and installation, seat belt lock	4-12	0210
4.16 Removal and installation, rapid-lowering handle	4-13	0210
4.17 Removal and installation, manifold	4-13	0210
4.18 Removal and installation, height control valve	4-15	0210
4.19 Removal and installation, vertical damping adjuster	4-16	0210
4.20 Removal and installation, height adjustment handle	4-17	0210
4.21 Removal and installation, seat tilting handle	4-18	0210
4.22 Removal and installation, backrest adjuster lever	4-19	0210
4.23 Removal and installation, backrest adjuster	4-19	0210
4.24 Removal and installation, lumbar position control valve	4-20	0210
4.25 Removal and installation, seat heating switch	4-21	0210
4.26 Removal and installation, vertical damper	4-21	0210
4.27 Removal and installation, air bellows	4-22	0210
4.28 Removal and installation, seat squab framework	4-23	0210
4.29 Removal and installation, framework of gas-sprung seat squab	4-25	0210
4.30 Removal and installation, height adjustment handle of gas-sprung seat ...	4-26	0210
4.31 Removal and installation, gas spring of gas-sprung seat	4-27	0210

1. SAFETY INSTRUCTIONS

- Replace the seat belt if the belt is worn or damaged.
- If the seat belts have been highly stressed during a collision, the entire mechanism must be replaced, even if no damage can be observed.
- Always check the seat attachments for any fractures or cracks after a collision.
- After a collision, always check whether the seat attachment bolts have been subjected to excessive stress.
- Do not use abrasive cleaning agents to clean the seat belts; these may damage the seat belt material.
- Seat repairs must be carried out by trained technicians only.
- The illustrations in this manual usually represent the left-hand seat or the left-hand side. For the right-hand seat or right-hand side, repairs are carried out in a similar way.
- After each repair, a functional test must be carried out; in the case of pneumatic repairs, also carry out an air-tightness test.
- Do not lean on the seat if the back rest has been fully folded forwards.
- It is necessary, however, to restore the routes of the air pipes and cables and their connections in the original positions.
- Also keep to the proper colour position when installing the air pipes.
- Air pipes and cables must not be kinked.
- In the case of transport and storage, ensure that the seat is placed on its longitudinal slides.

SEAT WITH SEAT BELT TENSIONERS

- If a seat is equipped with a seat belt tensioner, the system manual for the airbag and seat belt tensioner must be consulted for the various safety instructions and instructions for packing and treating pyrotechnic components.
- A seat with seat belt tensioner can be identified by the airbag. If a vehicle is equipped with an airbag, the driver seat automatically also has a pyrotechnic seat belt tensioner.
- A vehicle with an airbag can be identified by the text "airbag" on the steering wheel and by a sticker on the windscreen stating that the vehicle is equipped with an airbag.

2. GENERAL

2.1 OPERATION

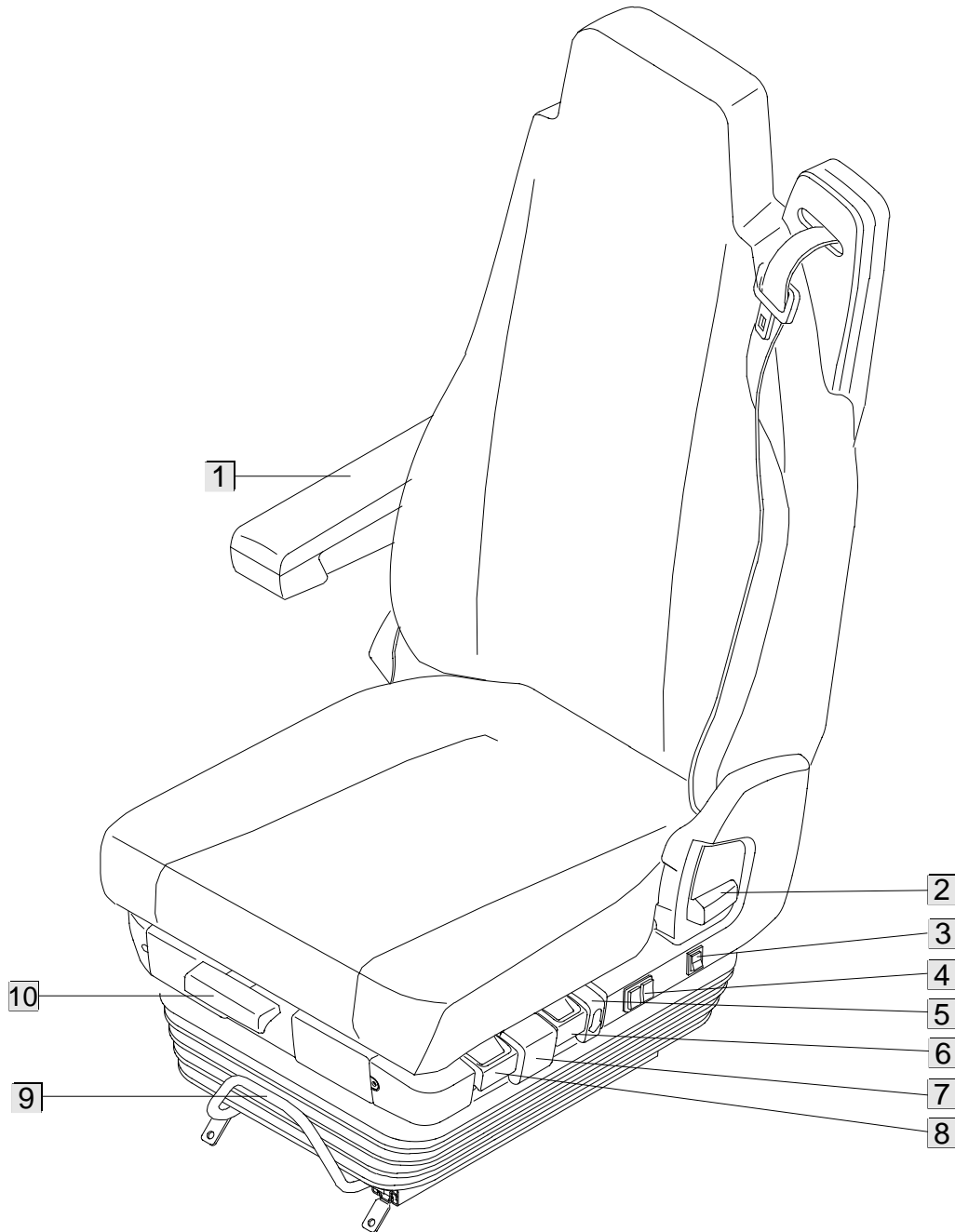

K1 01 371

Legend

- | | |
|--------------------------------------|--|
| 1. Arm rest | 6. Seat height operating lever |
| 2. Backrest adjuster operating lever | 7. Seat tilting operating lever |
| 3. Seat heating switch | 8. Operating lever for shock absorber adjuster |
| 4. Lumbar position switches | 9. Seat adjuster |
| 5. Rapid-lowering operating lever | 10. Seat squab adjuster |

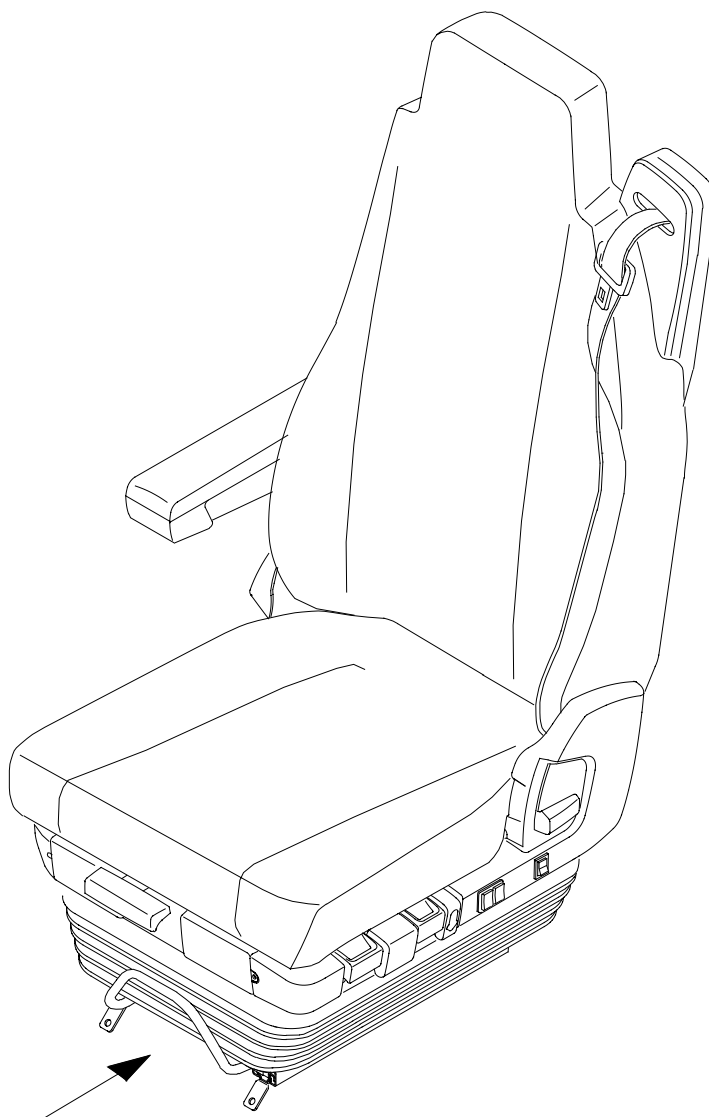
2.2 SERIAL/TYPE PLATE OF SEAT

K1 01 372

- The sticker with the serial number is located on the guide rail at the side of the seat. Other stickers with serial and part numbers are located on the front of the seat frame and are visible upon removal of the seat squab.
- When ordering parts, always state the serial number of the seat.

2.3 SYSTEM DESCRIPTION, AIR-SPRUNG SEAT

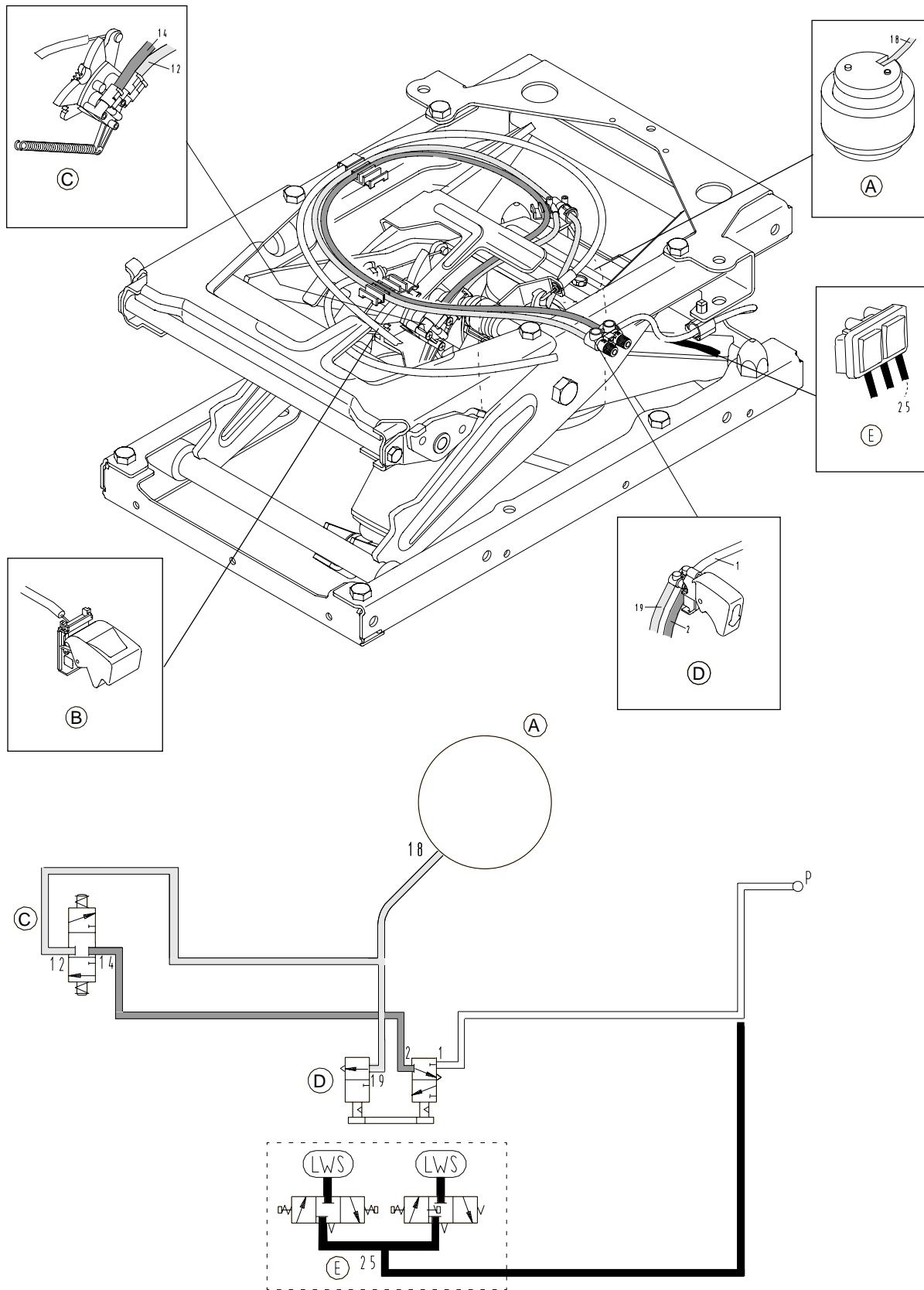

K1 01 373

Legend

- A. Air bellows
 - B. Height adjustment
 - C. Height control valve
 - D. Rapid-lowering valve
 - E. Lumbar position adjustment valve
- p. Air supply

2.4 OVERVIEW DRAWING, AIR-SPRUNG SEAT

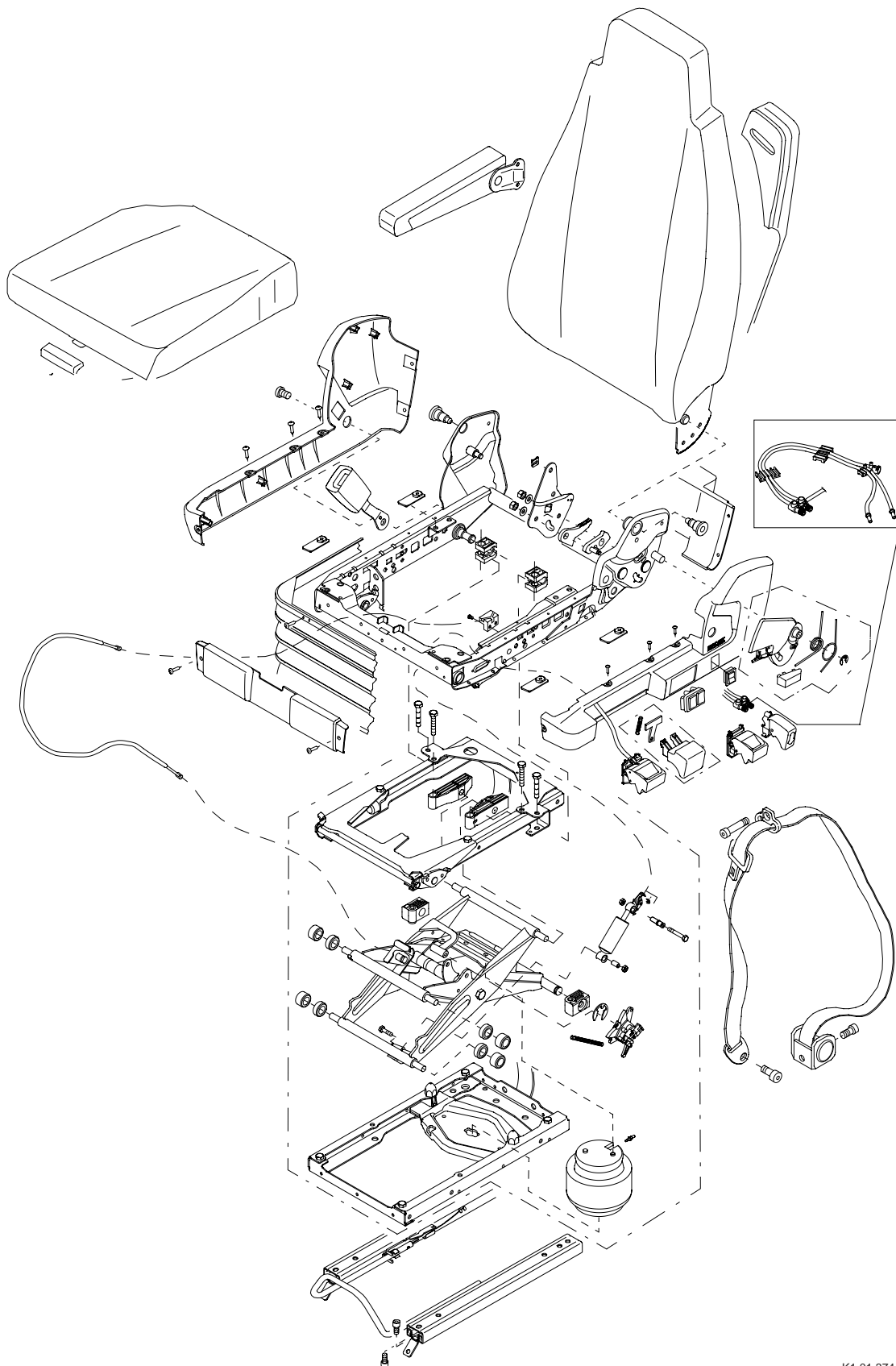

K1 01 374

2.5 OPERATION, GAS-SPRUNG SEAT

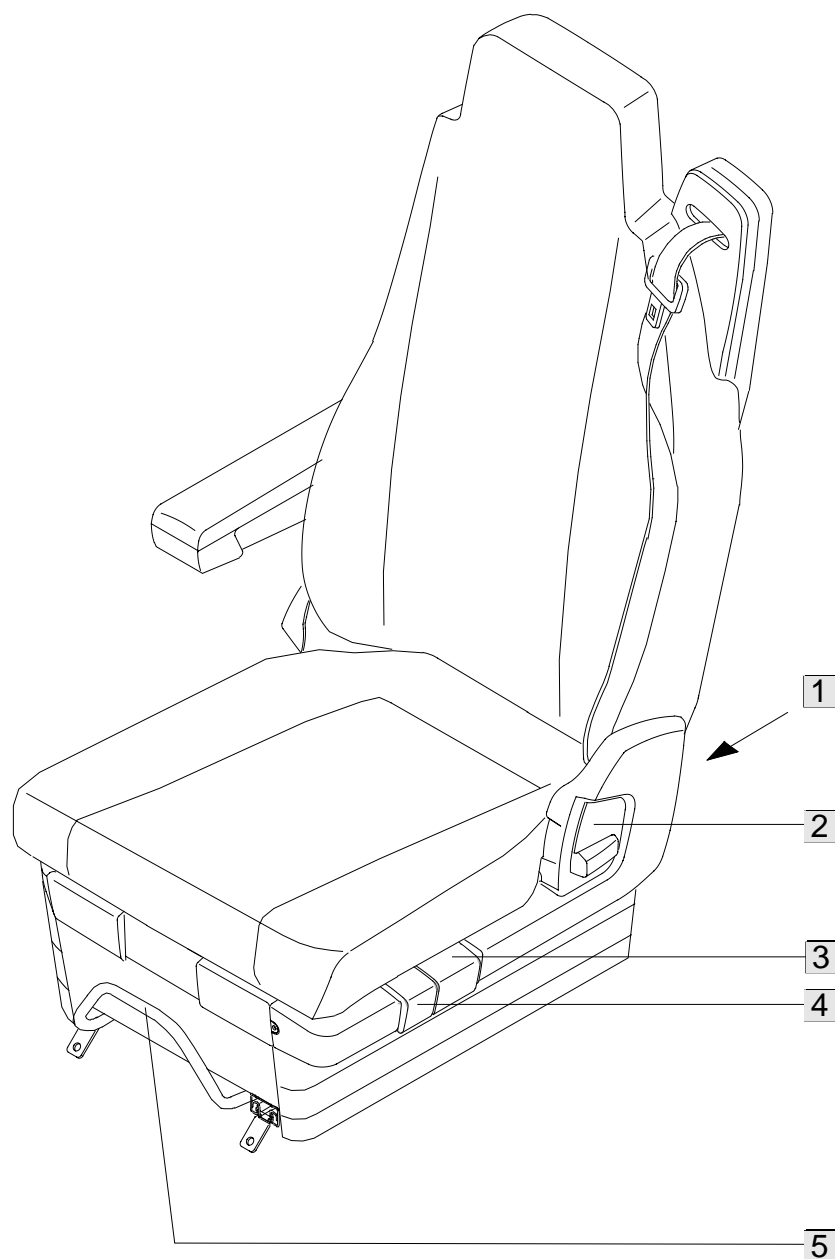

K1 01 375

Legend

1. Serial number
2. Backrest adjuster operating lever
3. Seat height operating lever
4. Seat tilting operating lever
5. Seat adjuster

2.6 OVERVIEW DRAWING, GAS-SPRUNG SEAT

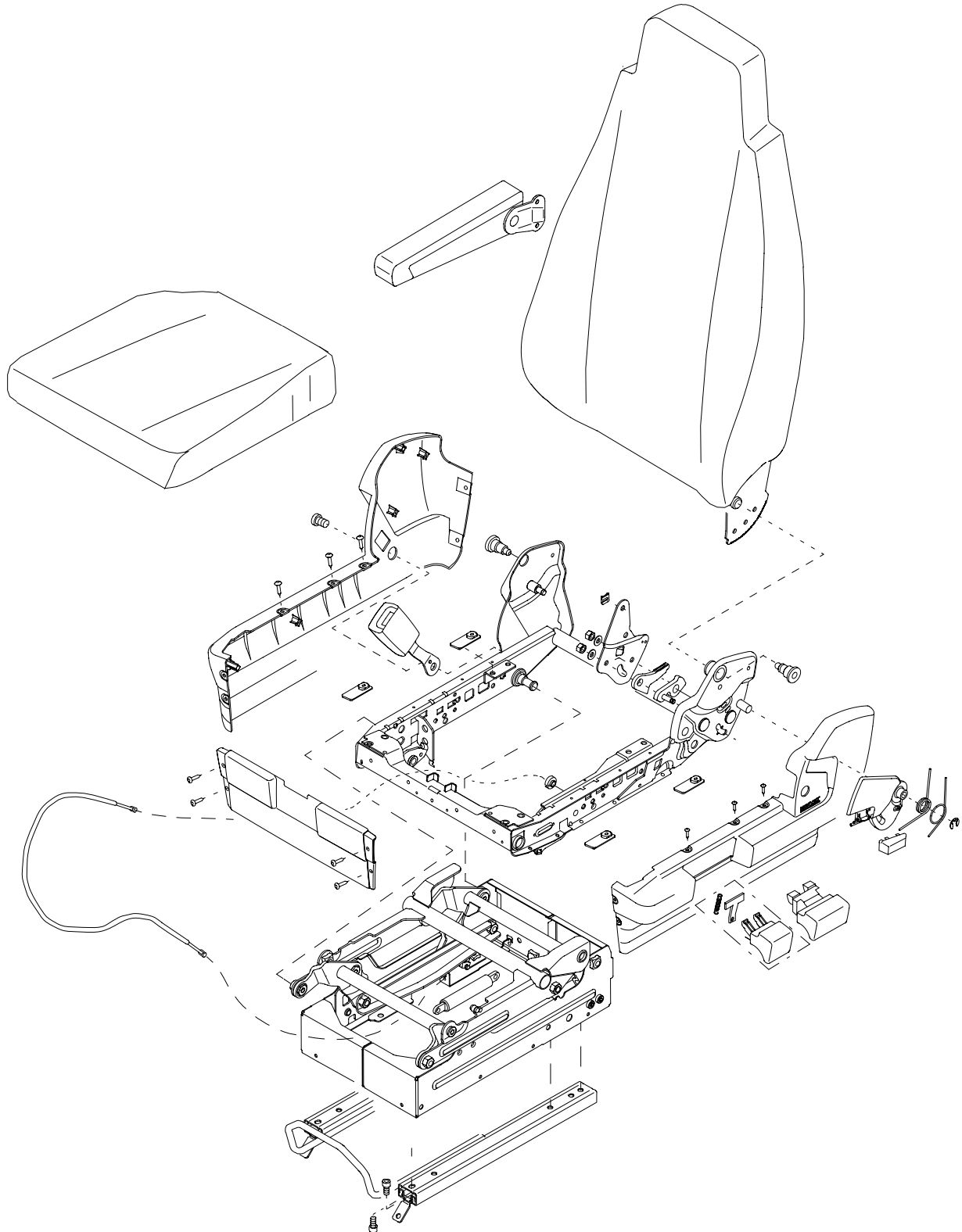

K1 01 376

3. INSPECTION AND ADJUSTMENT

3.1 INSPECTION, SEAT BELT OPERATION

- Pull the belt quickly out of its retracting unit to test the locking action. The belt must lock. It must not be possible to pull the belt out any further after locking.
- Check the seat belts for wear.

3.2 ADJUSTING THE CONTROL CABLE OF THE HEIGHT CONTROL VALVE

Adjusting the control cable of the height control valve

1. Remove the seat squab.
2. Loosen the lock nut of the cable tensioner (1).
3. Set the seat in its highest position.
4. Adjust the distance (X) between the operating lever (2) of the height control valve and the bottom air bellows carrier (3) to the prescribed distance, see "Technical data".

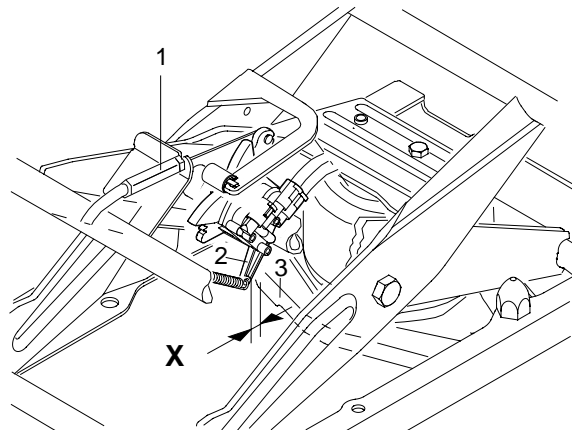

K1 01 377

4. REMOVAL AND INSTALLATION

4.1 REMOVAL AND INSTALLATION, SEAT ASSEMBLY

- If the seat is equipped with seat belt tensioners, turn the ignition off and disconnect the batteries before disconnecting the plug of the seat belt tensioner in the seat.
- If the vehicle is equipped with an airbag, the seat automatically has a seat belt tensioner. You can identify the presence of an airbag by the text on the steering wheel and a sticker on the windscreen stating "airbag".

Removing seat assembly

1. Remove the air pipe while pressing the circlip of the quick-release coupling and pulling the pipe from the coupling.
2. Detach the electric seat heating connector.
3. If applicable, unplug the seat belt tensioner connector.
4. Slide the seat backwards and remove the front attachment screws (1) of the seat slide.
5. Slide the seat forwards and remove the rear attachment screws (2) of the seat slide.
6. Remove the seat from the cab.

Installing seat assembly

1. Position the seat on the seat rails with the centring pins in the centring holes in the cab. Make sure that the air pipes and power supply cables do not get pinched off.
2. Slide the seat backwards and tighten the front attachment screws (1).
3. Slide the seat forwards and tighten the rear attachment screws (2).
4. Connect the air pipe.
5. Install the seat heating connector.

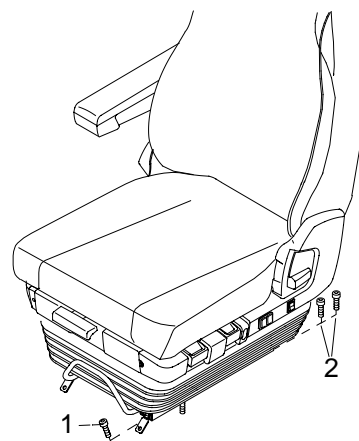

K1 01 378

6. Fit the seat belt tensioner connector.
7. Connect the batteries.

4.2 REMOVAL AND INSTALLATION, SEAT SLIDE

Removing seat slide

1. Remove the seat assembly.
2. Slide both seat slides forwards until the rear attachment screws (1) can be reached through the holes (2) in the slide.
3. Remove the rear attachment screws.
4. Slide the seat slides backwards.
5. Remove the front attachment screws (3).
6. Take the seat slides off the seat frame.

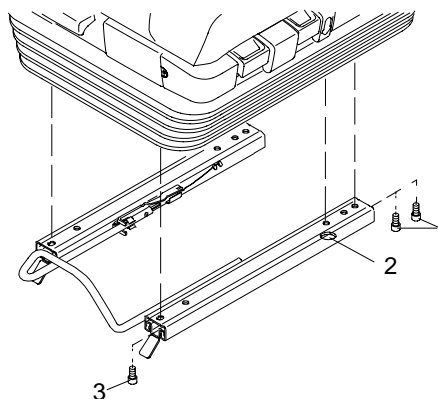

K1 01 379

Installing seat slide

1. Fit the seat slides to the seat frame using the front attachment screws (3).
2. Fit the rear attachment screws (2) through the mounting holes in the seat slides (1).
3. Install the seat assembly.

4.3 REMOVAL AND INSTALLATION, SEAT ADJUSTING MECHANISM

Removing seat adjusting mechanism

1. Slide the seat into the frontmost position.
2. Press the bracket (1) of the seat adjusting mechanism out of the attachment clamp (2) and the supporting cams (3).

Installing seat adjusting mechanism

1. Press the seat adjusting mechanism bracket (1) on either side into the attachment clamps (2) and the supporting cams (3).

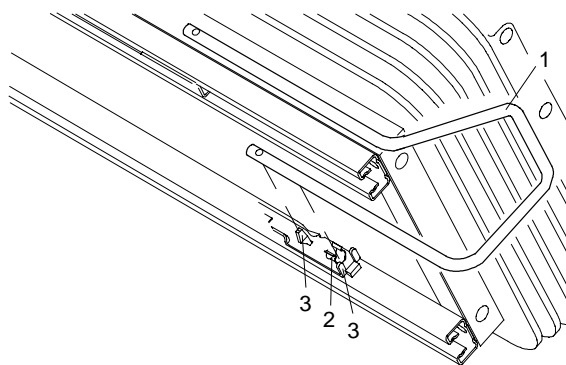

K1 01 380

4.4 REMOVAL AND INSTALLATION, SEAT SQUAB

Removing seat squab

1. Slide the seat squab into the frontmost position.
2. Detach the Velcro between the backrest and seat squab.
3. Put a screwdriver between the operating lever (1) of the seat squab and the seat frame.
4. Push the lever (1) up and to the right (A) until you can slide it over the locking mechanism on the seat frame.
5. Pull the squab further forwards. Lift the squab from the guides (3, 4).
6. In the case of seat heating, disconnect the electrical connector (5) at the rear and at the bottom of the seat squab.
7. If necessary, take the hand grip (2) off the operating lever (1).

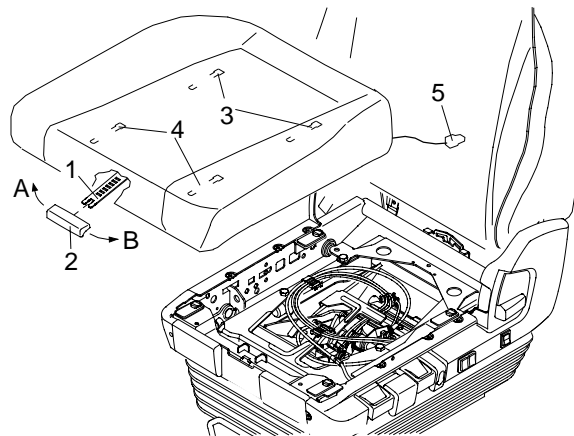

K1 01 381

Installing seat squab

1. If necessary, fit the hand grip (2) on the operating lever (1).
2. When installing the seat squab, slide it at the rear end onto the frame approximately 2 cm into the rearmost guides (3).
3. When doing so, press the seat squab down at the front and slide the seat squab into the frontmost guides (4) until the operating lever (1) of the seat squab snaps into position.
4. In the case of seat heating, connect the connector (5).
5. In the case of a stepwise adjustable seat squab check after installation that the slat of the operating lever (1) snaps into all openings. If necessary, move the slat to the left (B) or right (A) until it snaps.

4.5 REMOVAL AND INSTALLATION, SEAT SQUAB GUIDE

Removing seat squab guide

1. Remove the seat squab.
2. Remove the central circlip (1) from the seat squab guide (2).
3. Remove the seat squab guide (2) from the seat frame.

Installing seat squab guide

1. Fit the seat squab guide (2) on the seat frame.
2. Fit the central circlip (1) into the seat squab guide.
3. Fit the seat squab.

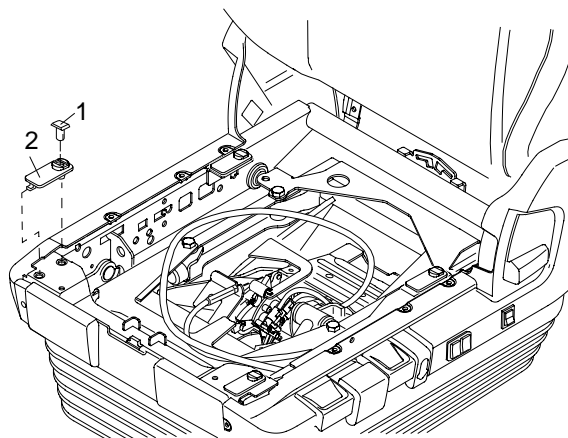

K1 01 382

4.6 REMOVAL AND INSTALLATION, FRONT COVER PANEL

Removing front cover panel

1. Remove the attachment screws of the front cover panel.
2. Detach the front cover panel from the side panels.

Installing front cover panel

1. Fit the front cover panel to the side panels using the attachment screws.

4.7 REMOVAL AND INSTALLATION, REAR COVER PANEL

Removing rear cover panel

1. Press the central locking pins (2) out of the attachment plugs (1), collect the locking pins (2) and keep them.
2. Take the attachment plugs (1) out of the attachment holes of the rear cover panel.
3. Detach the rear cover panel from the side panels.

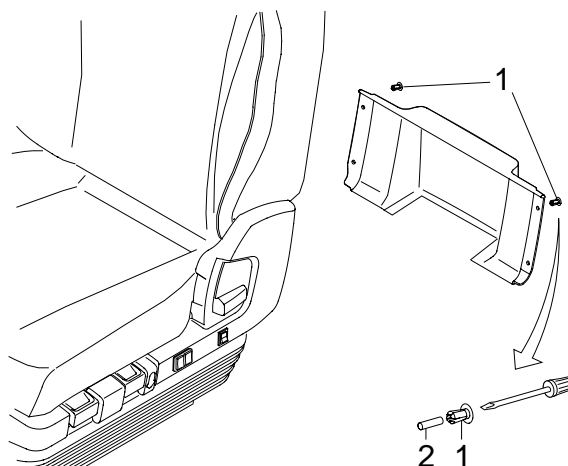

K1 01 383

Installing rear cover panel

1. Fit the rear cover panel to the side panels using the attachment plugs (1).
2. Secure the attachment plugs (1) by fitting the pins (2).

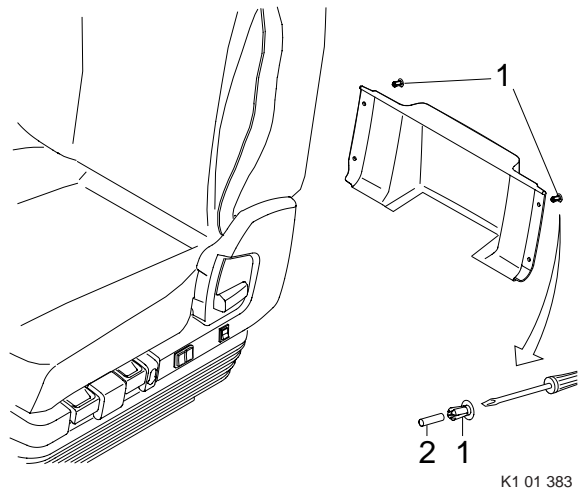
**4.8 REMOVAL AND INSTALLATION, COVER PANEL ON CONTROL SIDE****Removing cover panel on control side**

1. Remove the seat assembly.
2. Remove the seat squab.
3. Remove the front cover panel (5).
4. Remove the rear cover panel (1).
5. Fold the backrest forwards.
6. Remove the attachment screw (3) on the inside of the backrest hinge bracket.
7. Fold the backrest back.
8. Remove the attachment screws (2) on the seat frame.
9. Disconnect the air pipes on the switches of the lumbar support adjustment (8). You may mark the sequence of connection.
10. Disconnect the connector on the seat heating switch (9).
11. Disconnect the cover panel of the seat frame and tilt the cover panel over the backrest adjuster lever (7).

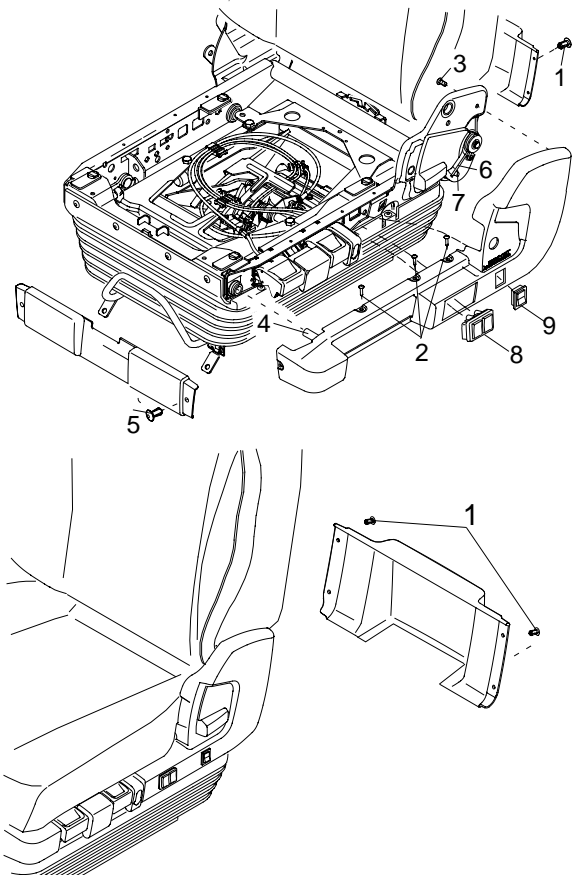

Installing cover panel on control side

1. Tilt the cover panel into mounting position over the backrest adjuster lever (7). Check that the reset spring (6) is still on the cam of the backrest adjuster lever (7).
2. Fit the air pipes of the lumbar support adjuster (8).
3. Fit the connector of the seat heating switch (9).
4. Fit the cover panel to the seat frame using the centring pin (4) and the attachment screws (2).
5. Fit the cover panel to the backrest hinge bracket using the attachment screw (3).
6. Fit the front cover panel (5), rear cover panel (1) and the seat squab.
7. Install the seat assembly.

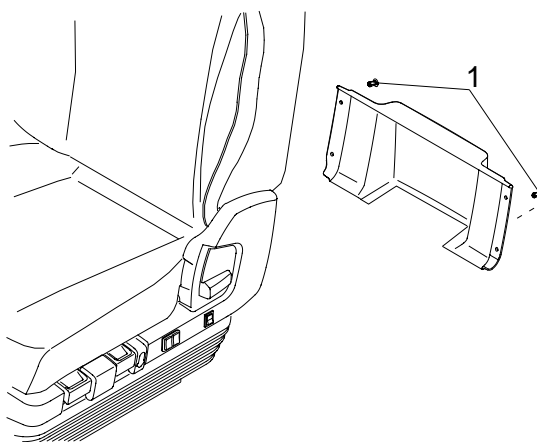
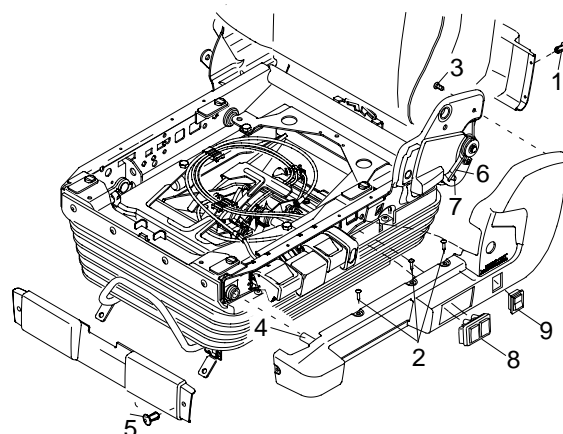

K1 01 384

4.9 REMOVAL AND INSTALLATION, COVER PANEL ON NON-CONTROL SIDE

Removing cover panel on non-control side

1. Remove the seat assembly.
2. Remove the seat squab.
3. Remove the front cover panel.
4. Remove the rear cover panel.
5. Remove the attachment screw on the inside of the backrest hinge bracket.
6. Remove the attachment screws on the seat frame.
7. Remove the attachment screw of the seat belt lock.
8. Remove the seat belt lock.
9. Remove the cover panel.

Installing cover panel on non-control side

1. Fit the cover panel to the seat frame and the backrest hinge bracket using the attachment screws.
2. Fit the seat belt lock using the attachment screw.
3. Fit the front cover panel using the attachment screws.
4. Fit the rear cover panel using the attachment plugs.
5. Fit the seat squab.
6. Install the seat assembly.

4.10 REMOVAL AND INSTALLATION, DUST BOOT**Removing dust boot**

1. Remove the seat assembly.
2. Remove the seat squab.
3. Remove all cover panels.
4. Remove the air pipe to the quick-release coupling on the connector block at the seat rear.
5. Disconnect the attachment caps and the clamps on the seat frame.
6. Pull the rubber dust boot at the front over the operating lever of the horizontal seat adjusting mechanism and the guide slides.
7. Remove the rubber dust boot completely from the seat.

Installing dust boot

1. Fit the rubber dust boot to the seat over the guide slides.
2. Fasten the rubber dust boot to the seat frame (all round) using the fastening caps. Press the attachment caps of the rubber dust boot into the attachment holes with a driving tool.
3. Fasten the dust boot with the clamps.
4. Fit the air pipe to the quick-release coupling on the connector block.
5. Fit all cover panels.
6. Fit the seat squab.
7. Install the seat assembly.

4.11 REMOVAL AND INSTALLATION, SEAT BELT GUIDE PANEL

Removing seat belt guide panel

1. Lift the operating lever of the backrest adjuster. Remove the attachment bolt (1) of the seat belt mount (2). Remove the seat belt mount (2).
2. Remove the attachment screws (3) of the seat belt guide panel from the backrest.
3. Lift the seat belt guide panel of the seat belt guide off the backrest. Guide the seat belt with mount and latch through the opening at the front of the seat belt guide panel (4).
4. Remove the seat belt guide panel from the backrest.

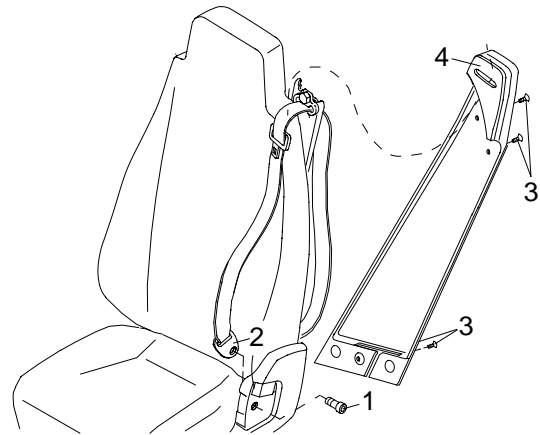

K1 01 385

Installing seat belt guide panel

1. Guide the seat belt with mount (2) through the opening of the seat belt guide panel (4).
2. Fit the seat belt guide panel to the backrest using the attachment screws (3).
3. Fit the seat belt mount (2) to the seat frame using the attachment bolt (1).

4.12 REMOVAL AND INSTALLATION, BACKREST

Removing backrest

1. Remove the seat assembly.
2. Remove the seat squab.
3. Remove all cover panels.
4. Remove the attachment bolts of the seat belt guide panel (3).
5. Remove the attachment screws (1) of the fastening strip (1).
6. Remove the seat belt guide (3) with seat belt from the backrest.

7. Disconnect the air pipes (7) to the backrest. Mark the position of the air pipes.
8. In the case of electric seat heating, disconnect the electrical connector (8) to the seat.
9. Remove the circlip (5) on the attachment screw (4) of the backrest hinge.
10. Remove the attachment screws (4) of the backrest hinges.
11. Remove the backrest from the seat frame.

Installing backrest

1. Install the backrest in the correct position on the seat frame.
2. Clean the attachment bolts (4) of the backrest hinge. Apply locking compound to the attachment bolts.
3. Fit the attachment bolts (4) in the backrest hinge. Fit the attachment bolt (4) with circlip (5).
4. Fit the air pipes (7) to the backrest.
5. In the case of electric seat heating, connect the electrical connector (8).
6. Fit the seat belt guide (3) with the attachment bolt (1) to the backrest.
7. Fit the seat belt guide panel to the backrest using the attachment bolts (2).
8. Fit all cover panels. Fit the seat squab.
9. Install the seat assembly.

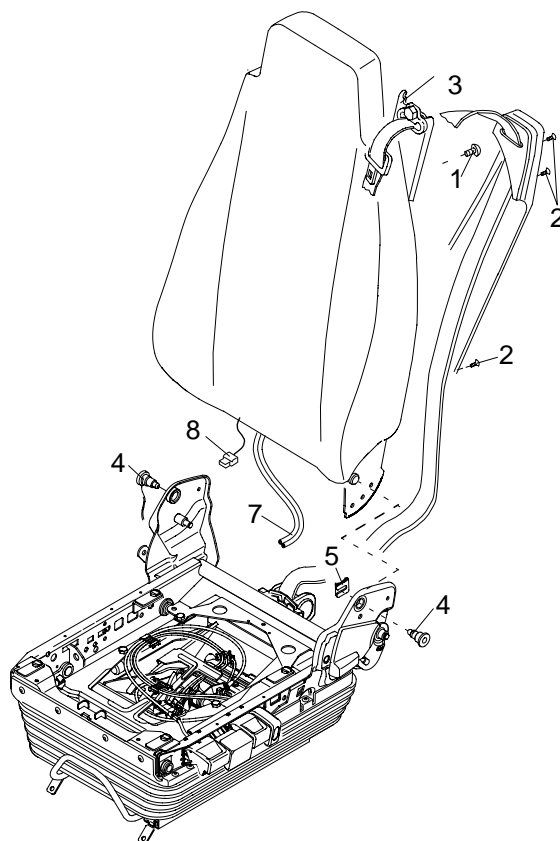

K1 01 386

4.13 REMOVAL AND INSTALLATION, ARM REST

Removing arm rest

1. Remove the cap on the attachment screw (1) in the arm rest.
2. Turn the attachment screw (1) of the arm rest out of the backrest and remove it.

Installing arm rest

1. Fit the arm rest to the backrest using the attachment screw (1).
2. Fit the cap on the attachment screw (1) in the arm rest.

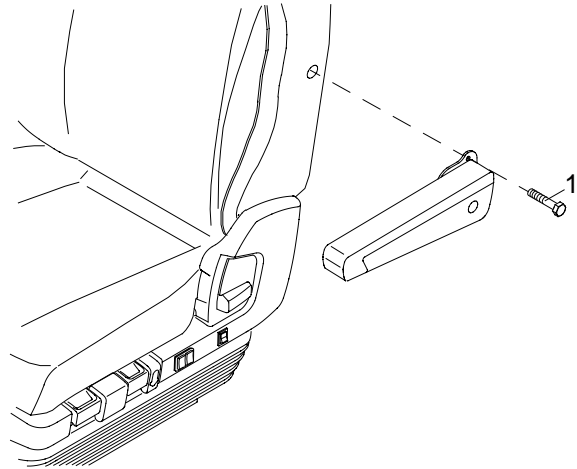

K1 01 387

4.14 REMOVAL AND INSTALLATION, SEAT BELT MECHANISM

- If a seat is equipped with a seat belt tensioner, the system manual for the airbag and seat belt tensioner must be consulted for the various safety instructions and instructions for removing, installing, packing and treating pyrotechnic components.
- A seat with seat belt tension can be identified by the airbag. If a vehicle is equipped with an airbag, the driver seat automatically also has a pyrotechnic seat belt tensioner.
- A vehicle with an airbag can be identified by the text "airbag" on the steering wheel and by a sticker on the windscreen stating that the vehicle is equipped with an airbag.

Removing seat belt mechanism

1. Remove the rear cover panel.
2. Lift the operating lever of the backrest adjuster and remove the attachment bolt (6) underneath of the seat belt mount. Remove the seat belt mount.
3. Remove the seat belt guide panel.

4. Remove the attachment bolt (1) of the seat-belt guide (2). Remove the seat-belt guide (2).
5. If there is a seat belt tensioner, disconnect the plug of the seat belt tensioner (5) on the seat belt roll (4).
6. Remove the attachment bolt (3) of the seat belt roll (4). Remove the seat belt roll (4).

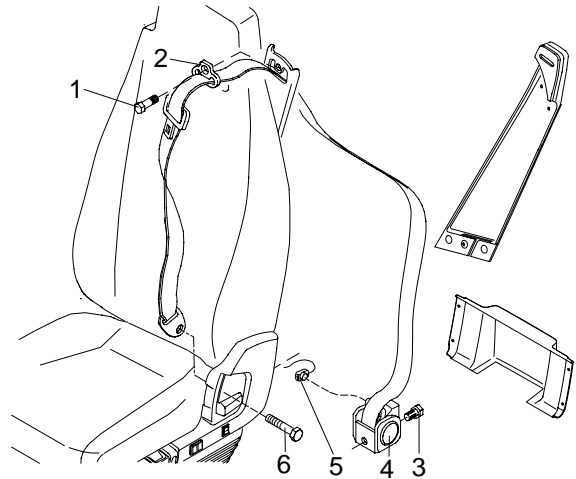

Installing seat belt mechanism

1. Fit the seat belt roll (4) to the frame using the attachment bolt (3). Tighten the attachment bolt to the specified tightening torque. See main group "Technical data".
2. Fit the seat belt guide (2) with seat belt to the backrest.
3. Fit the seat belt guide panel to the backrest.
4. Fit the seat belt mount to the seat frame using the attachment bolt (6) and tighten the attachment bolt to the specified tightening torque. See "Technical data".
5. Fit the rear cover panel to the seat frame.

4.15 REMOVAL AND INSTALLATION, SEAT BELT LOCK

7

Removing seat belt lock

1. Remove the attachment bolt (1) of the seat belt lock (2).
2. Take the seat belt lock (2) from the seat frame and the cover panel.

Installing seat belt lock

1. Fit the seat belt lock (2) through the opening in the cover panel.
2. Fit the seat belt lock (2) to the seat frame using the attachment bolt (1).
3. Tighten the attachment bolt (1) to the specified tightening torque. See main group "Technical data".

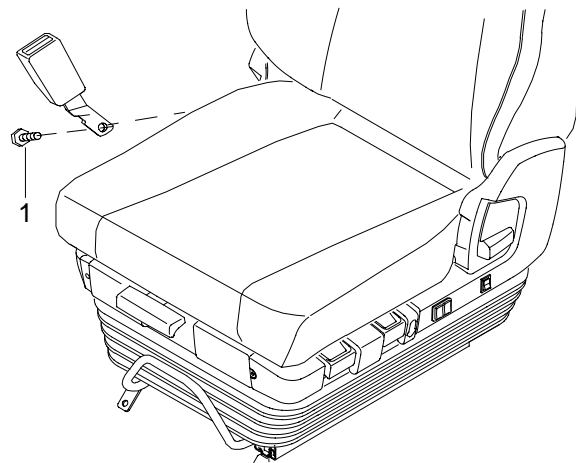

4.16 REMOVAL AND INSTALLATION, RAPID-LOWERING HANDLE

Removing rapid-lowering handle

1. Remove the seat squab.
2. Remove the attachment bolts (1) of the rapid-lowering handle.
3. Remove the rapid-lowering handle from the seat frame.

Installing rapid-lowering handle

1. Fit the rapid-lowering handle to the seat frame using the attachment screws.
2. Fit the seat squab.

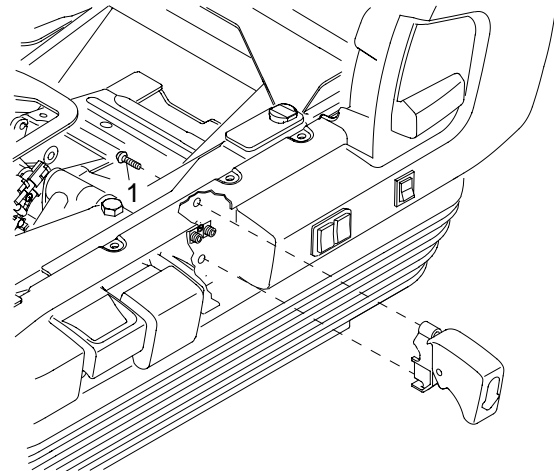

K1 01 390

4.17 REMOVAL AND INSTALLATION, MANIFOLD

Removing manifold

1. Remove the seat squab.
2. Lock the seat in its highest position using a spacer block. The spacer block serves to prevent the frame from lowering when work is carried out on the air pipes. Since you can easily make it yourself, it cannot be ordered from DAF. The block is sized 65x40x25 mm (LxWxH).
3. Remove rapid-lowering handle.

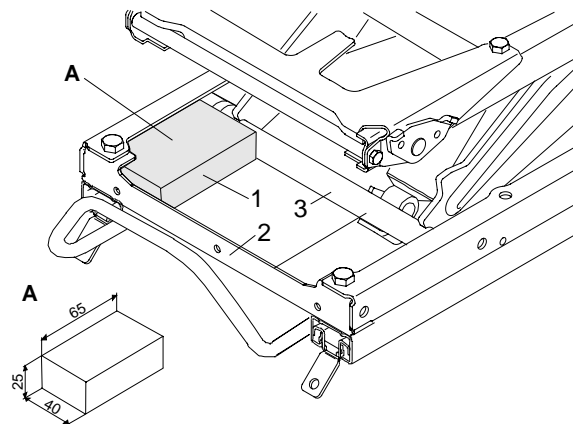

K1 01 402

4. Remove the attachment bolts (1) of the manifold (2).
5. Disconnect the manifold (2) from the seat frame.
6. When replacing the manifold, cut loose the transparent air supply pipe, approximately 3 cm from the manifold (3).
7. Remove the pipe guide (7) from the attachment clamp (10). Remove the control cable (5) from the pipe guide.
8. Disconnect the pipe guide (6).

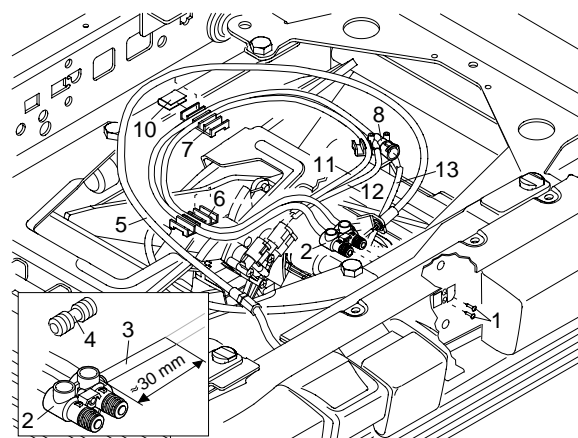

K1 01 391

9. Disconnect the air pipes (11) (red) and (12) (yellow) from the quick-release coupling to the height control valve.
10. Disconnect the air pipe (11) of the air bellows from the quick-release coupling (8).
11. Remove the complete manifold (2) with pipes from the seat frame.

Installing manifold

1. Repair the air supply pipe to the new manifold (2) using the repair kit (4) supplied.
2. Fit the manifold (2) on the seat frame.
3. Fit the control cable (5) in the pipe guide (7). Fit the pipe guide (7) in the attachment clamp (10).
4. Fit the pipe guide (6).
5. Lay the pipes back into the original position (before removal) in the pipe clips (6 and 7).
6. Connect the air pipe (11) of the air bellows to the quick-release coupling (8).
7. Connect the air pipes (11) (red) and (12) (yellow) to the height control valve.
8. Fit the rapid-lowering handle.
9. Remove the seat lock.
10. Check the pipes and system for air tightness and proper operation.
11. Fit the seat squab.

4.18 REMOVAL AND INSTALLATION, HEIGHT CONTROL VALVE

Removing height control valve

1. Remove the seat back.
2. Remove the air pipes (1) on the coupling piece of the height control valve. Note the position of the pipes.
3. Remove the attachment bolt (5) on the bracket (6). Remove the bracket.
4. Loosen nut (2) of the connection piece (3). Remove the control cable from the bracket.
5. Unhook the cable eye (4) from the lever.
6. Remove the reset spring (8) of the height control valve.
7. Snap the height control valve off the cross bar in the seat frame.

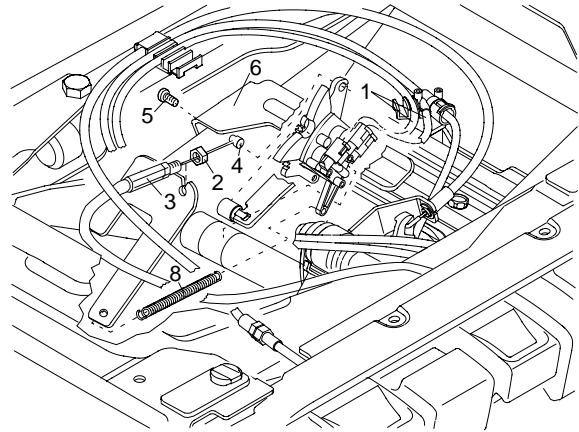

K1 01 392

Installing height control valve

1. Snap the height control valve onto the cross bar of the seat frame.
2. Fit the reset spring (8).
3. Install the bracket (6).
4. Hook the control cable (4) into the bracket. Fit the connection piece (3) with nut (2).
5. Fit the air pipes (1) in the quick-release coupling. Remember the sequence.
6. Check the pipes and system for air tightness and proper operation.
7. Fit the seat squab.

4.19 REMOVAL AND INSTALLATION, VERTICAL DAMPING ADJUSTER**Removing vertical damping adjuster**

1. Remove the seat squab.
2. Remove the attachment bolts (2) of the vertical damping lever (1).
3. Disconnect the vertical damping lever (1) from the seat frame.
4. Press the attachment pin (3) of the control cable (4) from the vertical damping lever (1).
5. Disconnect the control cable (4) from the vertical damping lever (1).
6. Disconnect the circlip (5) of the control cable on the fixing bracket near the shock absorber (6).
7. Unhook the control cable from the control lever of the shock absorber (6).

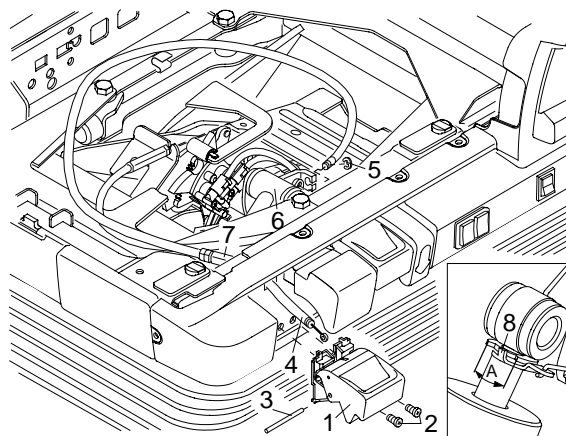

K1 01 393

Installing vertical damping adjuster

1. Hook the control cable into the control lever of the shock absorber (6).
2. Fasten the control cable in the fixing bracket near the shock absorber (6).
3. Secure the control cable on the fixing bracket using circlip (5).
4. Fit the control cable in the opening in the seat frame.
5. Fit the control cable (4) in the operating lever (1) using the attachment pin (3).
6. Fit the vertical damping lever (1) on the seat frame using the attachment bolts (2).
7. Loosen the lock nut of the control cable adjuster (7). Using the nut, adjust the cable until the movement of the control lever (8) on the shock absorber (6) covers the entire range (A).
8. Fit the seat squab.
9. Check the system for proper operation.

4.20 REMOVAL AND INSTALLATION, HEIGHT ADJUSTMENT HANDLE

Removing height adjustment handle

1. Remove the seat squab.
2. Remove the nut (4) of the control cable (3). Unhook the cable from the bracket (1).
3. Unhook the cable eye (5) from the control lever (7) of the height control valve.
4. Remove the attachment screws (1) of the operating handle (6).
5. Remove the operating handle (6) from the seat frame.
6. Remove the guide block (2) for the control cable (3) from the seat frame.
7. Remove the tension springs from the operating lever (6).
8. Remove the attachment pin from the components of the operating lever (6).
9. Detach the components of the operating handle (6) and unhook the control cable (3) from the attachment.

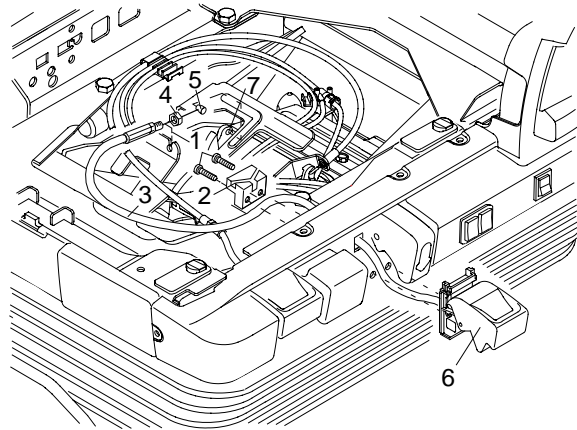

K1 01 394

Installing height adjustment handle

1. Hook the control cable (3) into the interior of the operating handle (6).
2. Assemble both components of the operating handle (6) using the attachment pin.
3. Fit the tension springs in the operating handle (6).
4. Fit the operating handle (6) with control cable (3) and guide block (2) on the seat frame.
5. Fit the control cable (3) on the bracket (1).
6. Hook the cable eye (5) into the lever (7) on the height control valve.
7. If necessary, readjust the control cable play.

4.21 REMOVAL AND INSTALLATION, SEAT TILTING HANDLE

Removing seat tilting handle

1. Remove the seat squab.
2. Press the locking lip at the bottom of the control button. Remove the control button from the handle.
3. Remove the reset spring (3) from the handle.
4. Push the spring end (1) of the seat angle lock out of the recess in the metal T-piece (2).
5. Remove the metal T-piece (2).
6. Tilt the handle out of the seat frame.

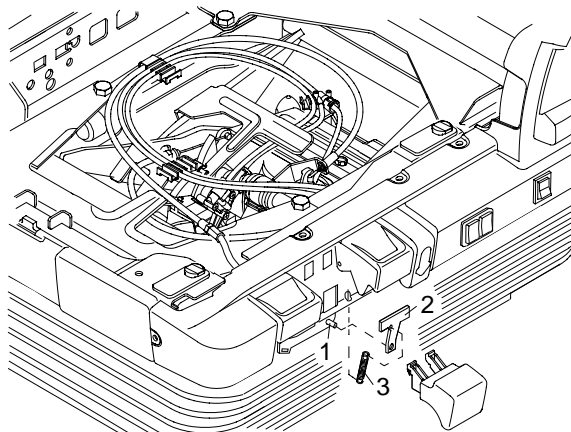

K1 01 395

Installing seat tilting handle

1. Tilt the handle into the seat frame.
2. Place the metal T-piece (2) back in the handle. Click the spring end (1) of the seat angle lock out into the recess in the metal T-piece (2).
3. Fit the reset spring (3) to the handle and the seat frame.
4. Click the control button onto the handle.
5. Fit the seat squab.

4.22 REMOVAL AND INSTALLATION, BACKREST ADJUSTER LEVER

Removing backrest adjuster lever

1. Remove the seat assembly.
2. Remove the seat squab.
3. Remove all cover panels.
4. Remove the circlip (1) on the operating lever (4).
5. Remove the lock washer (6) on the operating lever (4).
6. Slide the operating lever (4) with the springs (2, 3) off the hinge pin. Pay attention to the position of the springs (2, 3).

Installing backrest adjuster lever

1. Fit the operating lever (4) with the springs (2, 3) to the hinge pin.
2. Fit the lock washer (6) and the circlip (1) to the hinge pin.
3. Fit the cover panels and the seat squab.
4. Install the seat assembly.

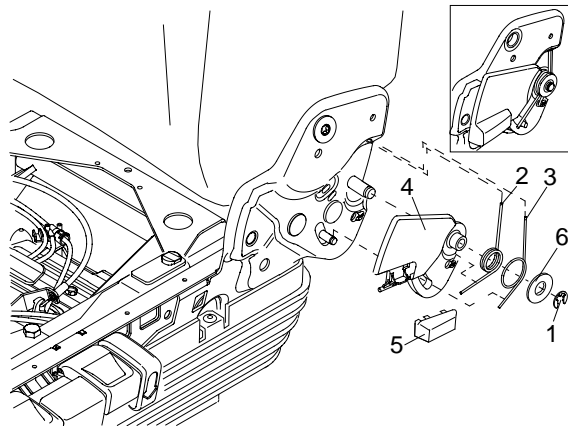

K1 01 396

4.23 REMOVAL AND INSTALLATION, BACKREST ADJUSTER

Removing the backrest adjuster

1. Remove the lumbar support.
2. Remove the circlip (1) from the locking plate (4) of the backrest adjuster.
3. Remove the attachment nuts (2) from the locking plate (4).
4. Hook the spring end (8) of the cam (7) onto the operating pin (6).
5. Remove the locking plate (4) with the locking pin (5) and the operating pin (6).

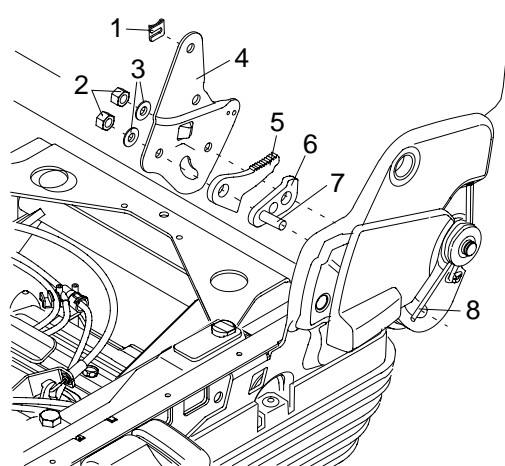

K1 01 397

Installing backrest adjuster

1. Place the locking plate (4) with the locking pin (5) and the operating pin (6) back on the mounting plate of the backrest adjuster.
2. Hook the spring end (8) of the cam (7) onto the operating pin (6).
3. Fix the locking plate (4) to the mounting plate using the attachment nuts (2).
4. Fit the circlip (1) to the locking plate.
5. Fit the back rest.

4.24 REMOVAL AND INSTALLATION, LUMBAR POSITION CONTROL VALVE**Removing lumbar position control valve**

1. Remove the cover panel on control side.
2. Disconnect the air supply pipe (3) from the coupling (4).
3. Disconnect the air pipes (1) to the lumbar cushions in the backrest from the connecting piece (2) or from the control valve (5) itself.
4. Remove the lumbar position control valve (5) from inside the cover panel.

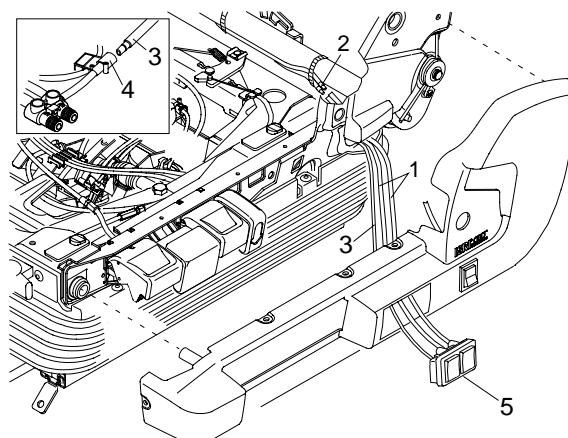

K1 01 398

Installing lumbar position control valve

1. Fit the lumbar position control valve (5) in the cover panel.
2. Fit the air pipes (3) of the lumbar cushions in the backrest to the connecting piece (2) or to the control valve (5) itself.
3. Connect the air supply pipe (3) to the coupling (4).
4. Fit the cover panel on control side to the seat frame.

4.25 REMOVAL AND INSTALLATION, SEAT HEATING SWITCH

Removing seat heating switch

1. Remove the cover panel on control side.
2. Unplug the connector (1).
3. Remove the seat heating switch (2) from inside the cover panel.

Installing seat heating switch

1. Connect the connector (1).
2. Fit the seat heating switch (2) in the cover panel.
3. Fit the cover panel on control side.

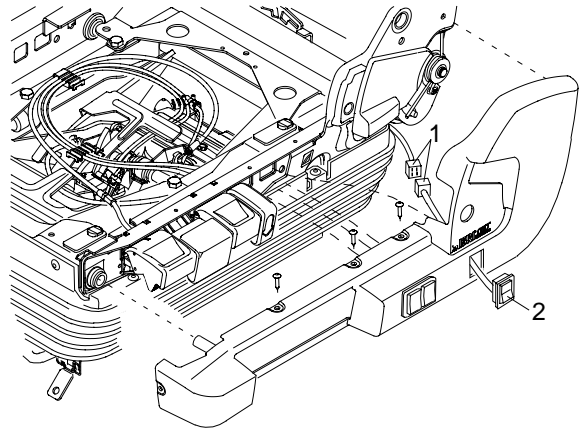

K1 01 399

4.26 REMOVAL AND INSTALLATION, VERTICAL DAMPER

Removing vertical damper

1. Remove the seat assembly.
2. Remove the seat squab.
3. Lock the seat in its highest position using a spacer block. The spacer block serves to prevent the frame from lowering when work is carried out on the air pipes. Since you can easily make it yourself, it cannot be ordered from DAF. The block is sized 65x40x25 mm (LxWxH).

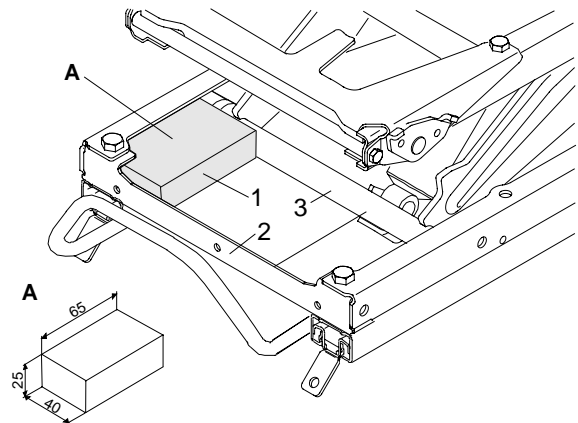

K1 01 402

4. Disconnect the circlip (6) of the control cable on the fixing bracket near the shock absorber (7).
5. Unhook the control cable from the control lever of the shock absorber (7).
6. Remove the attachment nuts (1, 5) and attachment bolts (2, 4) from the fixing bushes (3, 8) of the shock absorber (7).
7. Remove the shock absorber (7) from the seat frame.

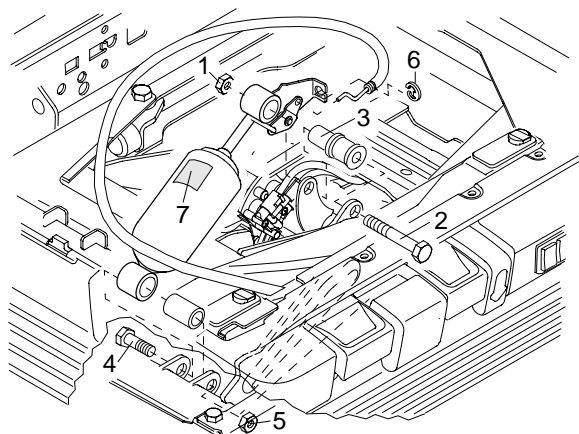

K1 01 400

Installing vertical damper

1. Fit the shock absorber (7) in the seat frame fixing brackets using the fixing bushes (3, 8), attachment nuts (1, 5) and attachment bolts (2, 4). Fit the shock absorber (7) with the sticker facing up.
2. Hook the control cable into the control lever of the shock absorber (6).
3. Fit the control cable to the fixing bracket of the shock absorber.
4. Fit the circlip (6) to the control cable.
5. Check the adjustment of the control cable.
6. Remove the seat lock.
7. Fit the seat squab.
8. Install the seat assembly.

4.27 REMOVAL AND INSTALLATION, AIR BELLOWS**Removing air bellows**

1. Remove the seat assembly.
2. Remove the seat squab.
3. Lock the seat in its highest position using a spacer block. The spacer block serves to prevent the frame from lowering when work is carried out on the air pipes. Since you can easily make it yourself, it cannot be ordered from DAF. The block is sized 65x40x25 mm (LxWxH).
4. Disconnect the quick-release coupling (5) of the air pipe (2) to the air bellows. Pay attention to the position of the air pipe.
5. Remove the attachment bolt (1) from the top of the air bellows.

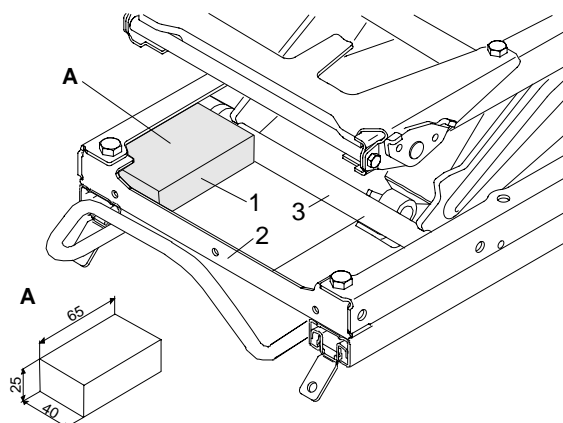

K1 01 402

6. Push the air bellows positioning bush (4) out of the upper cross member.
7. Loosen the air bellows a quarter stroke from the lower cross member (3). Take the air bellows out of the lower cross member.
8. Remove the air bellows from behind the seat frame.

Installing air bellows

1. Place the air bellows in the seat frame between the upper and lower cross members.
2. Turn the air bellows into the lower cross member (3). Pay attention to the position of the air pipe (2).
3. Fit the air bellows in the upper cross member using the attachment bolt (1); pay attention to the positioning bush (4).
4. Connect the air pipe (2) of the air bellows to the quick-release coupling (5).
5. Remove the seat lock.
6. Fit the seat squab.
7. Install the seat assembly.

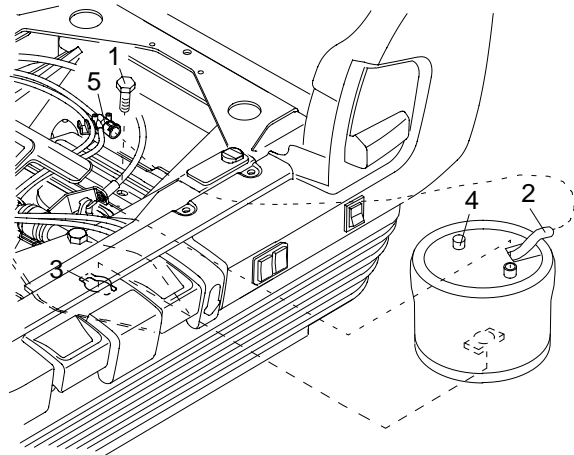

K1 01 401

4.28 REMOVAL AND INSTALLATION, SEAT SQUAB FRAMEWORK

Removing seat squab framework

1. Remove the seat assembly.
2. Remove the seat squab.
3. Remove all cover panels.
4. Remove the backrest (3) with the belt (1, 2).
5. Detach the dust boot from the framework.
6. Detach the control cable (5) from the vertical damper adjuster.
7. Disconnect the control cable (6) from the height control valve.

8. Disconnect the manifold (9) from the air pipes.
9. Remove the attachment bolts (7) from the rear hinges on the framework.
10. Set the largest possible angle and remove the front hinge bolts (8) from the framework.
11. Disconnect the air pipes from the framework.

Installing seat squab framework

1. Attach the framework on the frame using the front hinge bolts (8). Fit the air pipes.
2. Fit the rear hinges of the framework using the attachment bolts (7).
3. Fit the manifold (9).
4. Connect the control cable of the height control valve (6) and the vertical damper (5).
5. Fit the dust boot.
6. Fit the backrest, the belt and the cover panels.
7. Fit the seat squab.
8. Install the seat assembly.

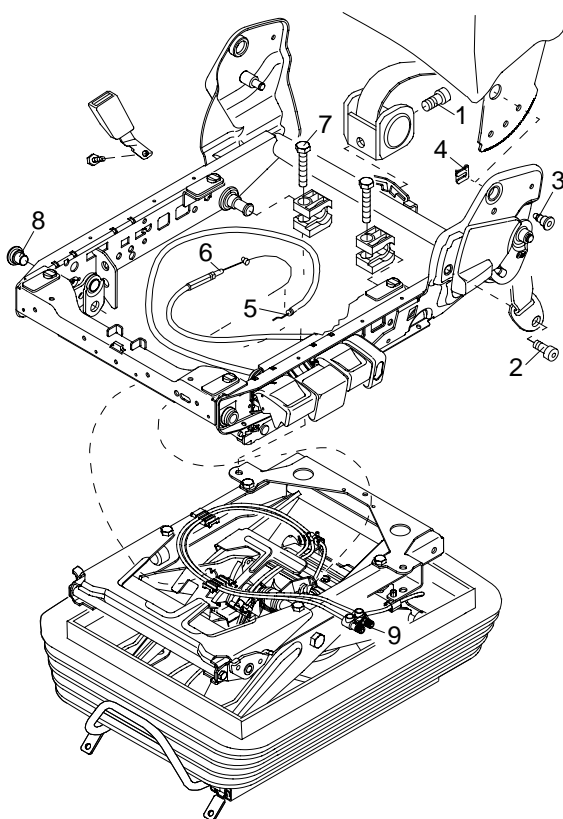

K0 01 403

4.29 REMOVAL AND INSTALLATION, FRAMEWORK OF GAS-SPRUNG SEAT SQUAB

Removing framework of gas-sprung seat squab

1. Remove the seat assembly.
2. Remove the seat squab and backrest assembly
3. Detach the control cable (1) from the height adjustment handle (2).
4. Adjust the seat to the correct position, remove the front (3) and rear (4) attachment bolts.

Installing framework of gas-sprung seat squab

1. Fit the front (3) and rear (4) attachment bolts.
2. Connect the control cable (1) to the height adjustment handle (2).
3. Fit the seat squab and backrest assembly
4. Fit the seat assembly.

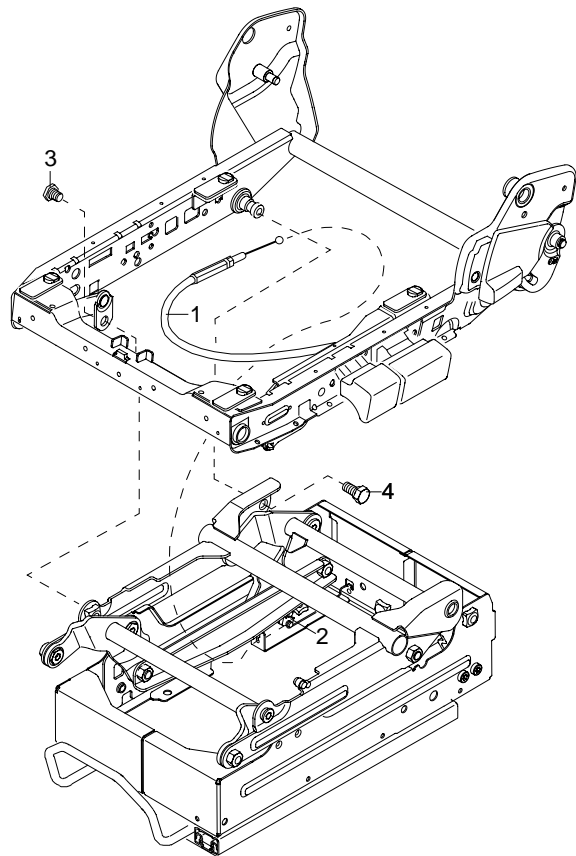

K1 01 404

4.30 REMOVAL AND INSTALLATION, HEIGHT ADJUSTMENT HANDLE OF GAS-SPRUNG SEAT

Removing height adjustment handle of gas-sprung seat

1. Remove the seat squab.
2. Press the locking lip at the bottom of the control button (1). Remove the control button from the handle (2).
3. Remove the circlip (3) from the control cable.
4. Push the pin (4) out of the handle (2).
5. Remove the control cable attachment ball (5) from the handle (2).
6. Remove the handle (2) from the frame.
7. Remove the reset spring (6).
8. Remove the stop (7). Unhook the attachment ball (8) from the handle (9).

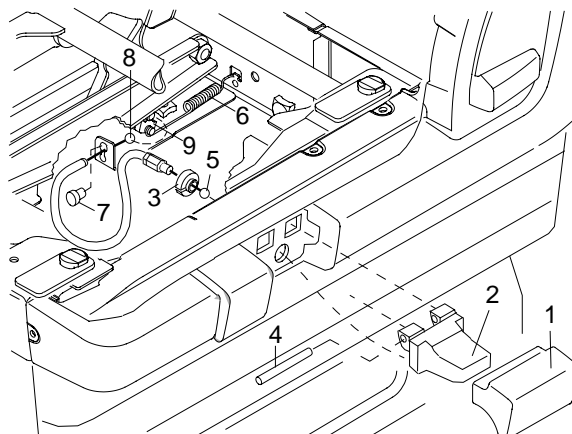

K1 01 405

Installing height adjustment handle of gas-sprung seat

1. Hook the attachment ball (8) into the handle (9). Fit the nut (7).
2. Fit the reset spring (6).
3. Fit the handle (2) into the frame.
4. Fit the attachment ball (5) into the handle (2).
5. Fit the pin (4) into the handle (2).
6. Fit the circlip (3) to the control cable.
7. Push the control button (1) on the operating handle (2).
8. Fit the seat squab.

4.31 REMOVAL AND INSTALLATION, GAS SPRING OF GAS-SPRUNG SEAT**Removing gas spring of gas-sprung seat**

1. Remove the seat squab.
2. Remove the nut (1).
3. Remove the circlip (2).
4. Remove the gas spring (3).

Installing gas spring of gas-sprung seat

1. Fit the gas spring (3).
2. Fit the circlip (2).
3. Fit the nut (1).
4. Fit the seat squab.

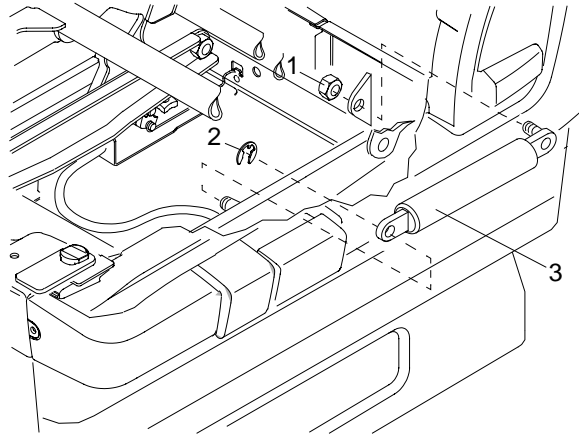

K1 01 406

CONTENTS

	Page	Date
1. SAFETY INSTRUCTIONS	1-1	0210
2. INSPECTION AND ADJUSTMENT	2-1	0210
2.1 Adjusting roof spoiler	2-1	0210
3. REMOVAL AND INSTALLATION	3-1	0210
3.1 Removal and installation, roof spoiler (aerodynamic)	3-1	0210
3.2 Removal and installation, roof spoiler (aerodynamic and adjustable)	3-2	0210
3.3 Removal and installation, rear air foils	3-3	0210
3.4 Removal and installation, windscreen sun visor	3-4	0210
3.5 Removal and installation, combi-light	3-4	0210
3.6 Removal and installation, seat covers	3-5	0210

1. SAFETY INSTRUCTIONS

General

The cab is equipped with a hydraulic tilting gear. The pump is located on co-driver's side at the rear of the cab. The cab locks are opened hydraulically during pumping.

Before tilting the cab, make sure that the doors are closed, that there are no loose items in the cab and that the gear lever is in neutral. Tilt the cab fully forward if work is to be carried out underneath the cab.



You can stop the cab tilting forward at any time by turning the tap to the reverse tilting position.

2. INSPECTION AND ADJUSTMENT

2.1 ADJUSTING ROOF SPOILER

Note:

Correct adjustment of the roof spoiler is essential to minimise fuel consumption.

1. Place the vehicle on a level and horizontal surface. Make sure that in the case of a tractor/semi-trailer combination the tractor is straight in front of the semi-trailer.
2. Determine the centreline of the vehicle and put a slat on the superstructure roof protruding into the cab direction.
3. Put another slat (as a tangent) onto the outer roof spoiler edge (P) pointing into the direction of the superstructure.
4. Both slats should cross at half the distance ($\frac{1}{2} X$) between the roof spoiler edge and the start of the superstructure.

The roof spoiler height can be adjusted using adjusting mechanism (B). For the roof spoiler adjusting range, see main group "Technical data".

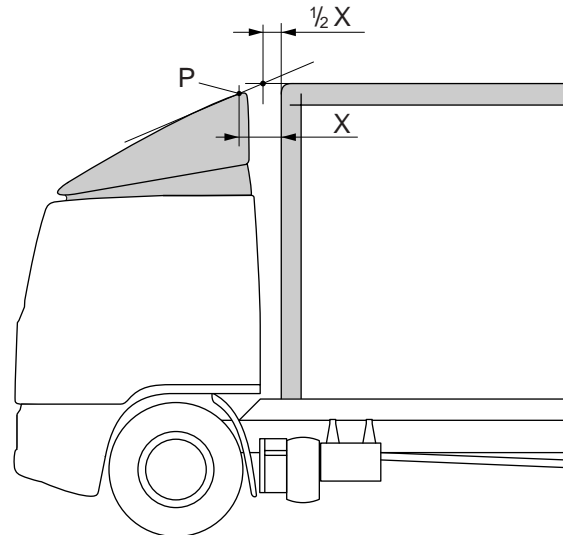

K1 01 357

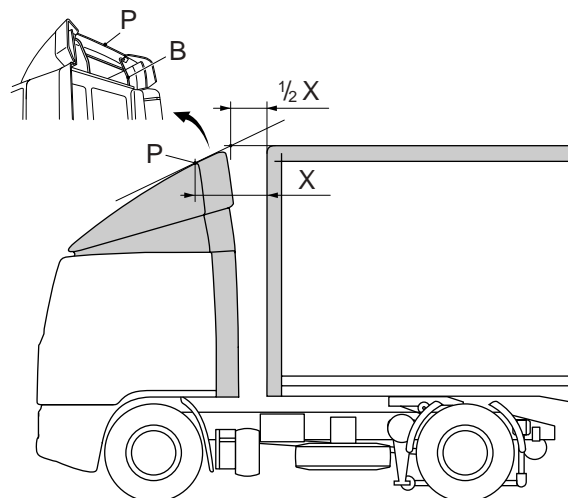

K1 01 356

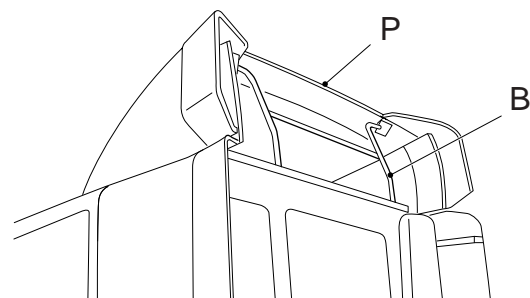

K1 01 355

3. REMOVAL AND INSTALLATION

3.1 REMOVAL AND INSTALLATION, ROOF SPOILER (AERODYNAMIC)

Removing roof spoiler (aerodynamic)

1. Remove the attachment nuts of the roof spoiler.
2. Carefully detach the roof spoiler assembly from the cab roof and carefully cut loose any sealant between the spoiler and cab roof.
3. Remove the residual sealant from the roof cab and roof spoiler.

Installing roof spoiler (aerodynamic)

1. Degrease the cab roof at the positions where the new sealant is to be applied.
2. Apply the specified sealant, see main group "Technical data", at the indicated positions on the cab roof.
3. Fit the roof spoiler assembly to the cab roof.
4. Fit the roof spoiler attachment nuts and tighten the attachment nuts to the specified tightening torque. See main group "Technical data".

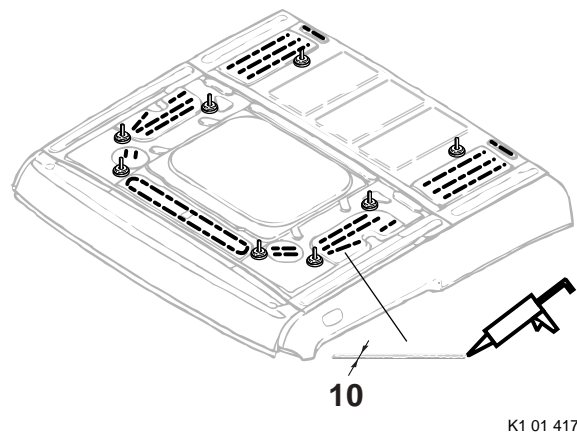
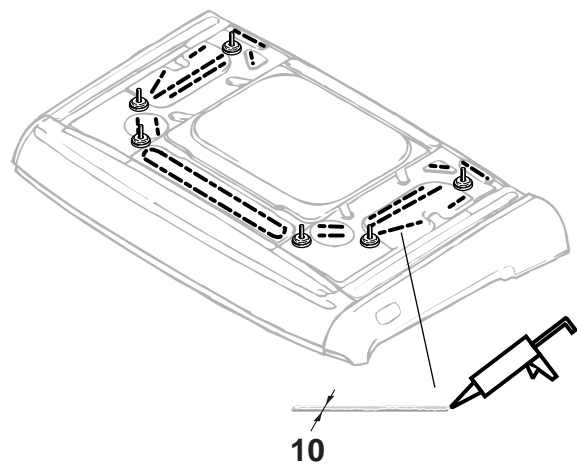

3.2 REMOVAL AND INSTALLATION, ROOF SPOILER (AERODYNAMIC AND ADJUSTABLE)

Removing roof spoiler (aerodynamic and adjustable)

1. Remove the attachment nuts of the roof spoiler.
2. Carefully detach the roof spoiler assembly from the cab roof and carefully cut loose any sealant between the spoiler and cab roof.
3. Remove the residual sealant from the roof cab and roof spoiler.

Installing roof spoiler (aerodynamic and adjustable)

1. Degrease the cab roof at the positions where the new sealant is to be applied.
2. Apply the specified sealant, see main group "Technical data", at the indicated positions on the cab roof.
3. Fit the roof spoiler assembly to the cab roof.
4. Fit the roof spoiler attachment nuts and tighten the attachment nuts to the specified tightening torque. See main group "Technical data".
5. Check the setting of the roof spoiler, see chapter "Inspection and adjustment".

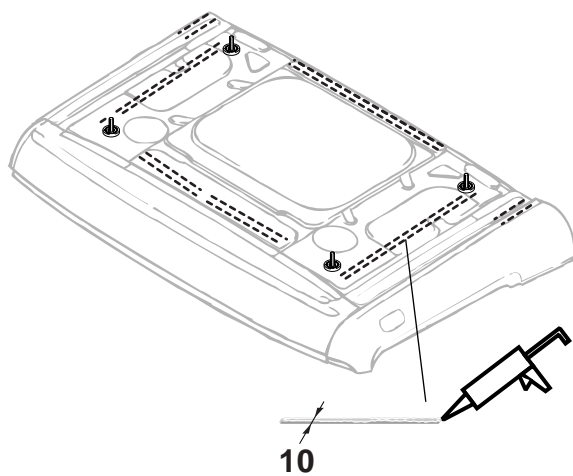

K1 01 418

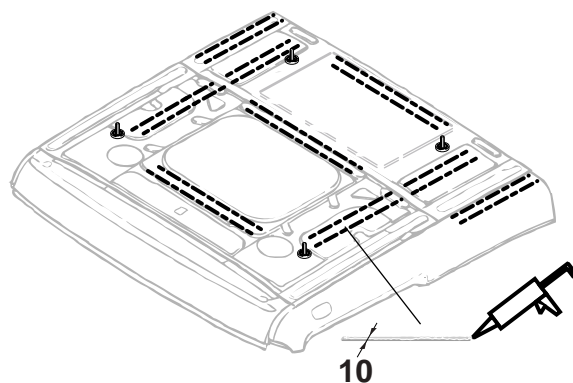

K1 01 419

3.3 REMOVAL AND INSTALLATION, REAR AIR FOILS

Removing rear air foils

1. Remove the attachment nuts of the cab wall attachment brackets.
2. Carefully detach the rear air foils from the cab and carefully cut loose any sealant between the cab and rear air foil.
3. Remove the residual sealant from the roof and rear air foil.

Installing rear air foils

1. Degrease the rear air foil parts and the cab at the positions where sealant is to be applied.
2. Position the rear air foil against the cab and check that the rear air foil fits the entire cab wall.
3. Put a plug in the drip channel between the rear air foil and the cab wall (A).
4. Apply the specified sealant to the attachment surfaces. See main group "Technical data".
5. Fit the rear air foil to the cab wall using the attachment nuts and tighten the attachment nuts to the specified tightening torque. See main group "Technical data".
6. Wait until the sealant has set and remove the plug from the drip channel.

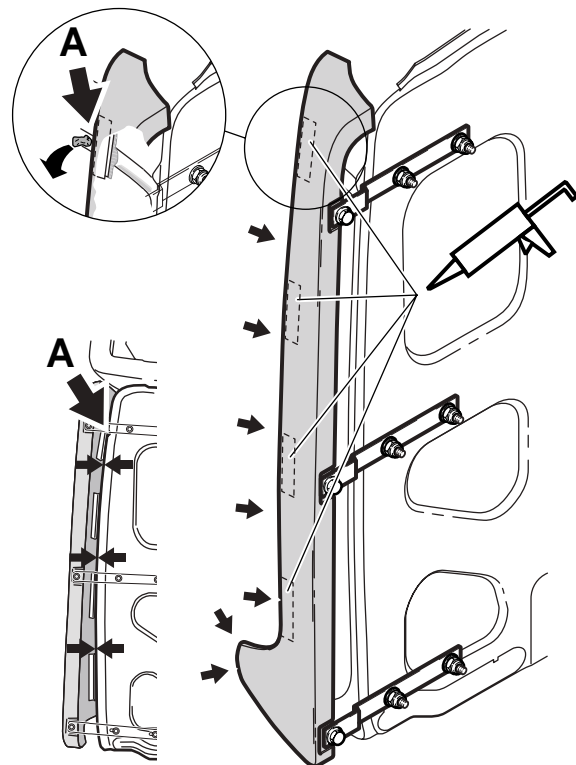

K1 01 420

3.4 REMOVAL AND INSTALLATION, WINDSCREEN SUN VISOR

Removing windscreen sun visor

1. Remove the attachment bolts of the attachment brackets from the threaded holes in the cab.
2. Remove the attachment brackets.

Installing windscreen sun visor

1. Fit the attachment brackets to the cab using the attachment bolts. Tighten the attachment bolts to the specified tightening torque. See main group "Technical data".

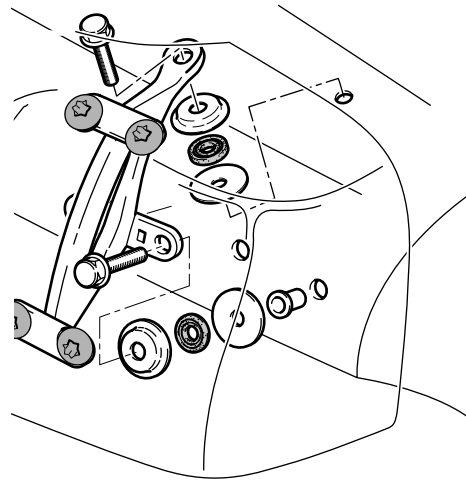

K1 01 421

3.5 REMOVAL AND INSTALLATION, COMBI-LIGHT

Removing combi-light

1. Remove the combi-light connector.
2. Remove the attachment screw (1) and take the combi-light out of the bumper.

Installing combi-light

1. Fit the combi-light with attachment screw (1) into the bumper.
2. Fit the combi-light connector.

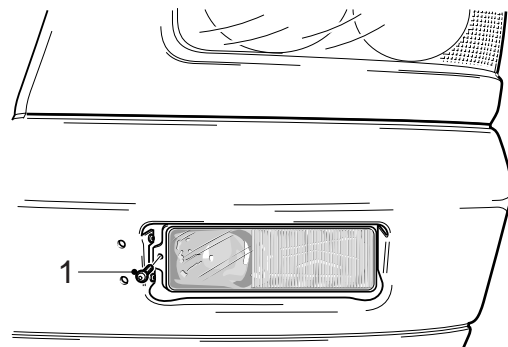

K1 01 358

3.6 REMOVAL AND INSTALLATION, SEAT COVERS

Removing seat covers

1. If necessary, remove the attachment bolts of the armrests and, if necessary, remove the armrests.
2. Remove the attachment bolts of the cover on the seat-belt guide.
3. Remove the cover of the seat-belt guide from the backrest.
4. Remove the attachment bolt of the seat-belt guide.
5. Remove the seat-belt guide from the backrest.
6. Remove the seat squab by pressing the releasing device of the seat adjusting mechanism at the front of the seat cushion.
7. Remove the seat cover from the backrest by detaching the cover at the bottom and pulling it upward.
8. Remove the seat cover from the seat by detaching the attachment hooks and pulling the cover from the seat.

Installing the seat covers

1. Fit the seat cover on the seat.
2. Tighten the seat cover on the seat, using the attachment hooks.
3. Fit the seat cover on the backrest.
4. Check that the attachment holes for the seat-belt guide and, if necessary, the armrests are free.
5. If applicable, fit the armrests to the backrest using the attachment bolts.
6. Fit the seat-belt guide to the backrest using the attachment bolt.
7. Fit the cover of the seat-belt guide to the backrest using the attachment bolts.
8. Slide the seat into the seat frame until it snaps into the lock.

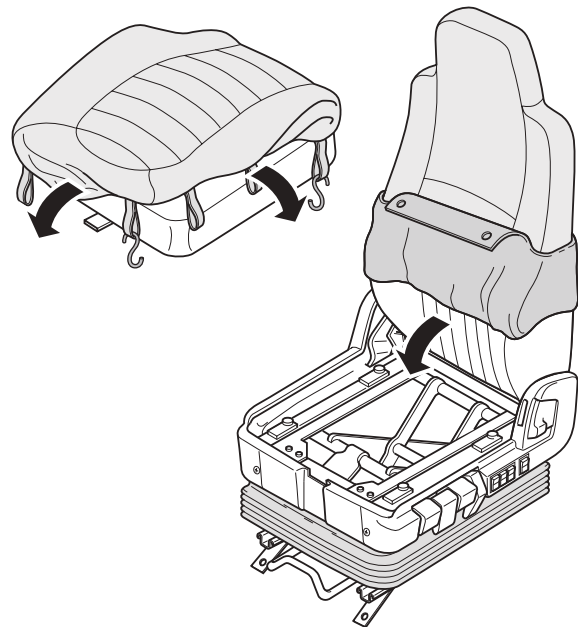

K1 01 422

