

TECHNICAL DATA	0
DIAGNOSTICS	1
BE ENGINE	2
BE ENGINE COOLING SYSTEM	3
BE ENGINE LUBRICATION SYSTEM	4
CE ENGINE	5
CE ENGINE COOLING SYSTEM	6
CE ENGINE LUBRICATION SYSTEM	7

CONTENTS

	Page	Date
1. BE ENGINE	1-1	200505
1.1 General	1-1	200505
1.2 Tightening torques	1-6	200505
2. BE ENGINE COOLING SYSTEM	2-1	200505
2.1 General	2-1	200505
2.2 Tightening torques	2-2	200505
2.3 Filling capacities	2-2	200505
3. BE ENGINE LUBRICATION SYSTEM	3-1	200505
3.1 General	3-1	200505
3.2 Tightening torques	3-3	200505
3.3 Filling capacities	3-4	200505
4. CE ENGINE	4-1	200505
4.1 General	4-1	200505
4.2 Tightening torques	4-6	200505
5. CE ENGINE COOLING SYSTEM	5-1	200505
5.1 General	5-1	200505
5.2 Tightening torques	5-2	200505
5.3 Filling capacities	5-2	200505
6. CE ENGINE LUBRICATION SYSTEM	6-1	200505
6.1 General	6-1	200505
6.2 Tightening torques	6-3	200505
6.3 Filling capacities	6-4	200505

1. BE ENGINE

1.1 GENERAL

Cold engine	A cold engine is an engine which, having reached operating temperature, has been allowed to cool down for at least six hours .
Warm engine	A warm engine is an engine which, having reached operating temperature, has been at a standstill for not more than thirty minutes .
Direction of rotation of the engine	The direction of rotation of the engine is clockwise, as seen from the vibration damper end.
First cylinder of the engine	The first cylinder of the engine is the cylinder at the vibration damper end of the engine.
Left-hand and right-hand side of the engine	The left-hand side of the engine is the side where the air compressor and electronic unit are mounted. The right-hand side of the engine is the side where the turbocharger and oil filter are mounted.

Engine types

Coding	BE 99 C BE 110 C BE 123 C
--------	---------------------------------

General specifications

Environmental standard	Euro 3 (C)
Number of cylinders	4 cylinders in line
Valves	4 per cylinder
Bore x stroke	102 x 120 mm
Cubic capacity	3.9 litres
Weight	approx. 391 kg
Cooling	fluid
Air inlet system	Turbocharger intercooling
Fuel injection	direct
Injection sequence	1-3-4-2

Compression ratio

BE 99 C	17.0 : 1
BE 110 C	17.0 : 1
BE 123 C	17.3 : 1

ENGINE TYPE	P (kW) at rpm	M (Nm) at rpm
BE 99 C	99 at 2500	500 at 1200 - 1600
BE 110 C	110 at 2500	550 at 1250 - 1600
BE 123 C	123 at 2500	600 at 1200 - 1600

Intake manifold

Fit the intake manifold using sealant Loctite Ultra Grey

Exhaust manifold

Maximum flatness deviation 0.20 mm

0

Cylinder block

Flatness deviation in longitudinal direction max. 0.076 mm
 Flatness deviation in lateral direction max. 0.051 mm

Cylinder head

Rough value 0.4 - 1.6 mm
 Flatness deviation in longitudinal direction max. 0.305 mm
 Flatness deviation in lateral direction max. 0.076 mm
 Test pressure with air max. 2.75 bar
 Water test temperature approx. 60°C

Cylinder head gasket

Thickness: 1.15 mm

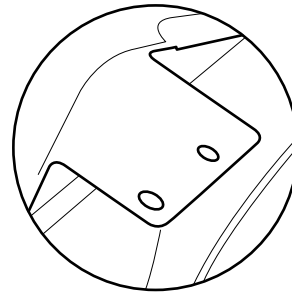

M201231

Thickness: 1.25 mm

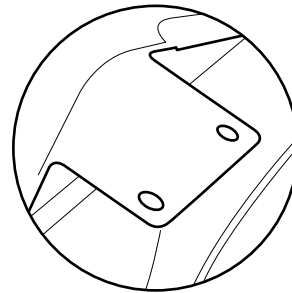

M201232

Type of cylinder head gasket to be used:

Average piston protrusion	Thickness of cylinder head gasket
< 0.301 mm	1.15 mm
≥ 0.301 mm	1.25 mm

Cylinder head bolts

Maximum dimensions of visible corrosion or pitting 1 cm²
 Maximum pitting depth 0.12 mm

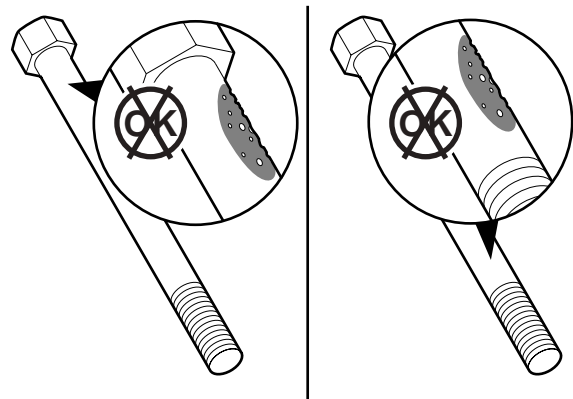

M201249

Length of area below bolt head and just above beginning of screw thread where corrosion or pitting is not allowed (A)

3.2 mm

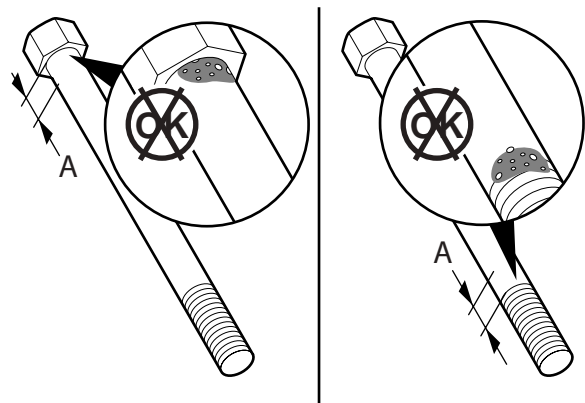

M201250

Maximum free length of short cylinder head bolt (130 mm nominal)

132.1 mm

Maximum free length of long cylinder head bolt (150 mm nominal)

152.1 mm

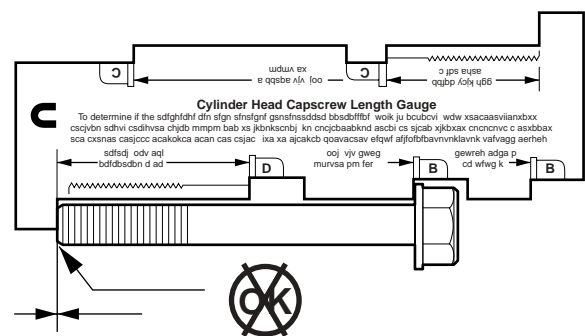

M201252

Valve clearance

Inspection dimensions, cold valve clearance

Intake

0.15 - 0.40 mm

Exhaust

0.40 - 0.75 mm

Setting dimensions, cold valve clearance

Intake

0.25 mm

Exhaust

0.50 mm

Timing gear

Fit the timing gear case using sealant

Loctite Ultra Grey

Front engine panel

Fit front engine panel using sealant

Loctite Ultra Grey

Gear backlash

Crankshaft gear - camshaft gear

0.076 - 0.28 mm

Oil pump gear - idler gear

0.250 - 0.30 mm

End float

Crankshaft end float

0.267 ± 0.165 mm

Camshaft end float

0.230 ± 0.130 mm

Oil sump pressure

New engine

60 - 80 l/min.

Worn engine

180 l/min.

0

Oil sump pressure conversion table	
Inches (water)	Litres per minute (l/min.)
1	50
2	84
3	103
4	119
5	133
6	145
7	155
8	164
9	172
10	180
11	187
12	193
13	200
14	206
15	211
16	217
17	222
18	226
19	229
20	232

Flywheel/starter ring gear

Radial run-out, measured on the inside of the flywheel outer edge (A)	max. 0.127 mm
Axial deviation, measured on the flywheel outer edge (B)	max. 0.406 mm
Heat starter ring gear (max. 20 min.)	max. 125°C

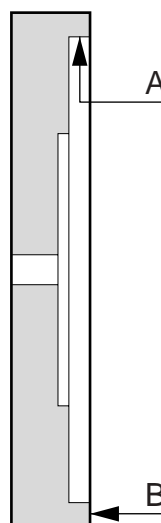

M201199

Flywheel housing

Fit flywheel housing using sealant

Loctite 5205

Vibration damper

Difference in thickness at 4 places must not exceed

6.35 mm

1.2 TIGHTENING TORQUES

The tightening torques stated in this section are different from the standard tightening torques stated in the overview of the standard tightening torques. The other threaded connections not specified must therefore be tightened to the torque stated in the overview of standard tightening torques.

When attachment bolts and nuts are replaced, it is important that - unless stated otherwise - these bolts and nuts are of exactly the same length and property class as those removed.

Starter motor

Attachment bolts 43 Nm

Automatic poly-V-belt tensioner

Attachment bolts 43 Nm

Alternator

Alternator bracket attachment bolts 30 Nm

Alternator attachment bolts 60 Nm

Pulley attachment nut 80 Nm

Air compressor

Compressor attachment nuts 80 Nm

Pipe attachments 39 Nm

Steering pump

Attachment bolts, steering pump 55 Nm

Line connection in the pump, delivery side 36 Nm

Attachment bolts, cover 20 Nm

Attachment bolts, reservoir 8 Nm

Air-conditioning compressor

Compressor support attachment bolts 30 Nm

Compressor attachment bolts 60 Nm

Valve gear

Rocker setting bolt lock nut 24 Nm

Valve sleeve attachment bolts 24 Nm

Valve cover attachment bolts 10 Nm

Rocker seat attachment bolts 36 Nm

Injector wiring 1 Nm

Intake manifold

Intake manifold attachment bolts	24 Nm
Fuel rail attachment bolts	24 Nm
Glow element attachment bolts	14 Nm
Air inlet hose clamps	7 Nm

Exhaust manifold

Attachment bolts	43 Nm ⁽¹⁾
Heat shields	56 - 64 Nm

(1) Tighten crosswise from inside to outside.

Cylinder head**Note:**

Apply a drop of engine oil on the thread of the attachment bolts and under the bearing surface of the bolt heads.

Phase 1

All attachment bolts 35 Nm ⁽¹⁾

(1) Tighten the bolts in the order indicated

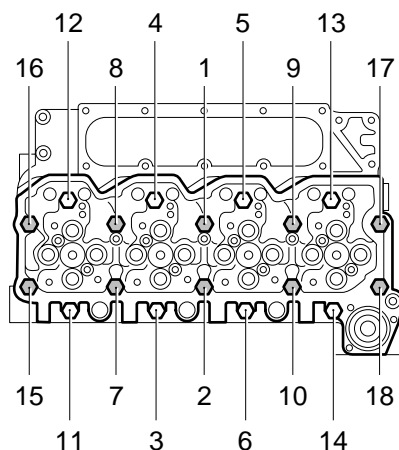

M201142

Phase 2

Use **only** attachment bolts that are 150 mm in length 55 Nm ⁽¹⁾

(1) Tighten the bolts in the order indicated

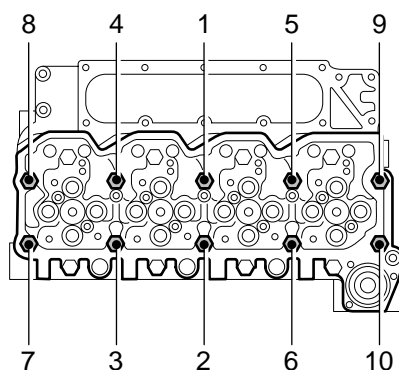

M201201

0

Phase 3

All attachment bolts 2 steps of 90° angular displacement each ⁽¹⁾

(1) Tighten the bolts in the order indicated

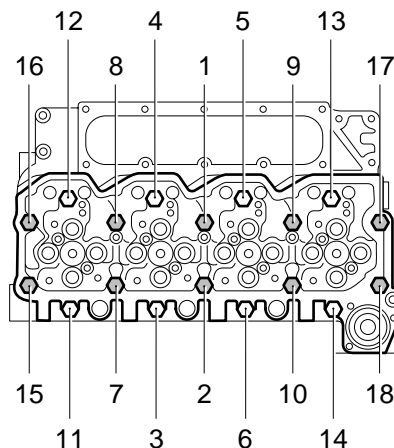

M201142

Vibration damper

Attachment bolts 95 Nm

Timing gear

Camshaft locking plate attachment bolts 24 Nm
 M8 attachment bolts for timing gear case 24 Nm
 M10 attachment bolts for timing gear case 47 Nm
 M12 attachment bolts for timing gear case 50 Nm
 Camshaft gear attachment bolts 36 Nm

Attachment bolts, cap, front of engine

Attachment bolts, cap, front of engine ⁽¹⁾ 24 Nm

(1) Tighten the attachment bolts in the order indicated

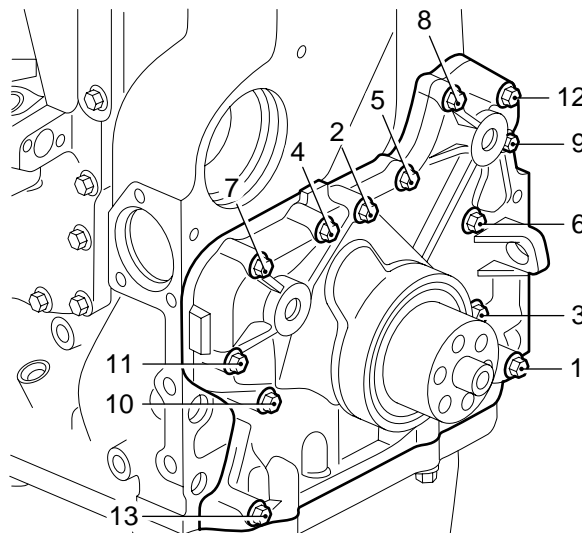

M201144

Flywheel

Attachment bolts 30 Nm + 60° angular displacement

Flywheel housing

M10 attachment bolts ⁽¹⁾	49 Nm
M12 attachment bolts ⁽¹⁾	85 Nm

(1) Tighten the attachment bolts in the order indicated

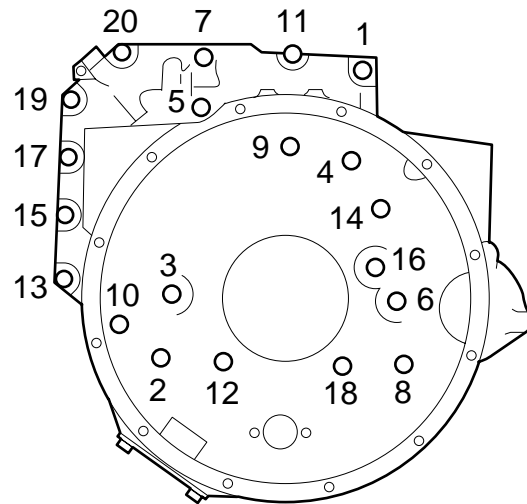

M201080

Engine mounting, front

Engine bracket attachment bolts/nuts 110 Nm

Engine mounting, rear

Bolts attaching engine bracket to chassis	110 Nm + 90° angular displacement
Bolts attaching engine bracket to engine	110 Nm + 60° angular displacement
Bolts attaching support to engine bracket	170 Nm + 90° angular displacement

Engine hanger brackets

Front engine hanger bracket attachment bolts	77 Nm
Rear engine hanger bracket attachment bolts	43 Nm

2. BE ENGINE COOLING SYSTEM

2.1 GENERAL

Thermostat

Thermostat opening temperatures:

thermostat opens at

approx. 81°C

thermostat fully open at

approx. 94°C

Full thermostat opening at

14.3 mm

Header tank pressure cap

Pressure relief valve opening pressure

approx. 0.75 bar

Vacuum relief valve opening pressure

approx. 0.1 bar

Pressure-testing cooling system

Test pressure

0.5 - 0.7 bar

Cleaning cooling system

Product name	Properties	Applications	DAF number
RP cleaner	Cleaning time 45 min. with engine running	Cleaning cooling system	1334996

0

2.2 TIGHTENING TORQUES

The tightening torques stated in this section are different from the standard tightening torques stated in the overview of the standard tightening torques. The other threaded connections not specified must therefore be tightened to the torque stated in the overview of standard tightening torques.

When attachment bolts and nuts are replaced, it is important that - unless stated otherwise - these bolts and nuts are of exactly the same length and property class as those removed.

Coolant pump

Attachment bolts 24 Nm

Thermostat housing

Attachment bolts 10 Nm

Radiator

Attachment nuts 89 Nm

2.3 FILLING CAPACITIES

Cooling system capacity approx. 20 litres

3. BE ENGINE LUBRICATION SYSTEM

3.1 GENERAL

Oil pressure

Lubricating oil pressure at engine idling speed	min. 0.69 bar
Lubricating oil pressure at full-load engine speed	min. 2.07 bar
Bypass pressure regulator opening pressure	3.52 bar

Oil filter

Type	disposable filter
Number	1
Location in the oil circuit	full flow

Oil cooler

Oil cooler pressure test temperature	approx. 60°C
Oil section test pressure	4.5 - 5.0 bar
Opening pressure of bypass valve at a pressure difference of	3.45 bar

Lubricating oil pump

Maximum clearance, inner rotor - outer rotor	0.178 mm
--	----------

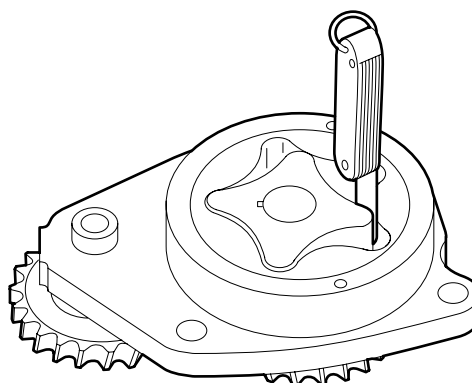

M201077

Maximum clearance, outer rotor - pump housing	0.381 mm
---	----------

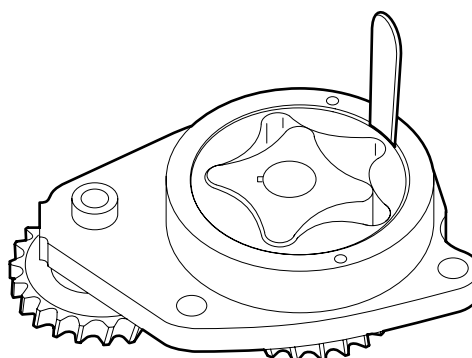

M201076

0

Maximum clearance of inner and outer rotor relative to the pump housing, measured with a straight edge

0.127 mm

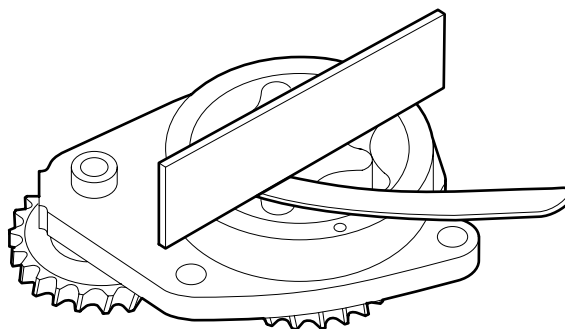

M201075

Lubricating oil pump gear backlash

Lubricating oil pump idler gear - lubricating oil pump gear

0.25 - 0.30 mm

Crankshaft gear - lubricating oil pump idler gear

0.15 - 0.25 mm

Crankshaft gear - lubricating oil pump gear

0.30 - 0.50 mm

Oil consumption

Maximum permissible engine oil consumption

0.5% of the average fuel consumption

Example:

Average measured fuel consumption:

25 litres/100 km = 250 litres/1000 km

Maximum permissible engine oil consumption:

$0.5\% \times 250 = 1.25$ litres/1000 km

- Engine oil consumption of 1.25 litres / 1000 km is permissible
- Engine oil consumption > 1.25 litres / 1000 km; check the engine using the diagnostics table. See "Diagnostics".

3.2 TIGHTENING TORQUES

The tightening torques stated in this section are different from the standard tightening torques stated in the overview of the standard tightening torques. The other threaded connections not specified must therefore be tightened to the torque stated in the overview of standard tightening torques.

When attachment bolts and nuts are replaced, it is important that - unless stated otherwise - these bolts and nuts are of exactly the same length and property class as those removed.

Oil sump

Oil sump attachment bolts 24 Nm ⁽¹⁾

Oil drain plug 60 Nm

(1) Tighten the attachment bolts in the order indicated

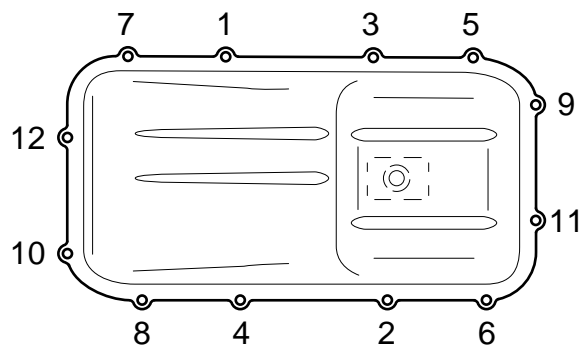

M201078

Oil cooler

Attachment bolts connecting oil cooler to cylinder block 24 Nm ⁽¹⁾

(1) Tighten the attachment bolts in the order indicated

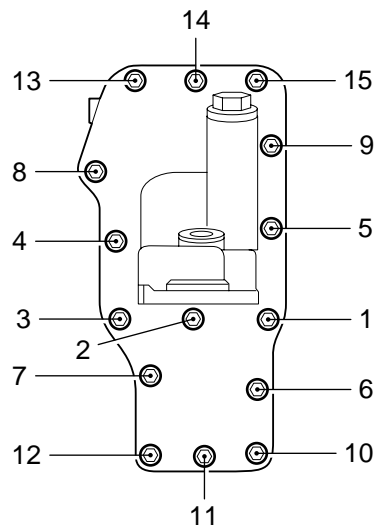

M201145

0**Oil pump**

Attachment bolts 24 Nm

Turbocharger oil supply pipe

Union on filter head 24 Nm

Union on turbocharger 28 Nm

3.3 FILLING CAPACITIES**Lubrication system**

Total capacity, including oil cooler and oil filter 13 litres

Oil sump capacity, maximum level 11 litres

Oil sump capacity, minimum level 8.9 litres

4. CE ENGINE

4.1 GENERAL

Cold engine	A cold engine is an engine which, having reached operating temperature, has been allowed to cool down for at least six hours .
Warm engine	A warm engine is an engine which, having reached operating temperature, has been at a standstill for not more than thirty minutes .
Direction of rotation of the engine	The direction of rotation of the engine is clockwise, as seen from the vibration damper end.
First cylinder of the engine	The first cylinder of the engine is the cylinder at the vibration damper end of the engine.
Left-hand and right-hand side of the engine	The left-hand side of the engine is the side where the air compressor and electronic unit are mounted. The right-hand side of the engine is the side where the turbocharger and oil filter are mounted.

Engine types

Coding	CE 136 C CE 162 C CE 184 C
--------	----------------------------------

General specifications

Environmental standard	Euro 3 (C)
Number of cylinders	6 cylinders in line
Valves	4 per cylinder
Bore x stroke	102 x 120 mm
Cubic capacity	5.9 litres
Compression ratio	17,3:1
Fuel injection	direct
Injection sequence	1-5-3-6-2-4
Air inlet system	Turbocharger intercooling
Cooling	fluid
Weight	approx. 498 kg

ENGINE TYPE	P (kW) at rpm	M (Nm) at rpm
CE 136 C	136 at 2500	700 at 1200 - 1600
CE 162 C	162 at 2500	820 at 1250 - 1600
CE 184 C	184 at 2500	950 at 1200 - 1600

Intake manifold

Fit the intake manifold using sealant Loctite Ultra Grey

Exhaust manifold

Maximum flatness deviation 0.20 mm

Cylinder block

Flatness deviation in longitudinal direction max. 0.076 mm
Flatness deviation in lateral direction max. 0.051 mm

0

Cylinder head

Rough value 0.4 - 1.6 mm
 Flatness deviation in longitudinal direction max. 0.305 mm
 Flatness deviation in lateral direction max. 0.076 mm
 Test pressure with air max. 2.75 bar
 Water test temperature approx. 60°C

Cylinder head gasket

Thickness: 1.15 mm

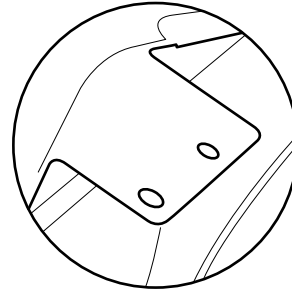

M201231

Thickness: 1.25 mm

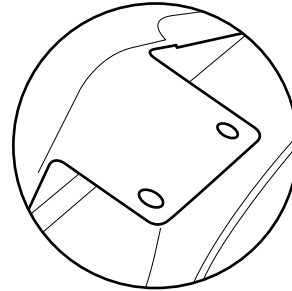

M201232

Type of cylinder head gasket to be used:

Average piston protrusion	Thickness of cylinder head gasket
< 0.301 mm	1.15 mm
≥ 0.301 mm	1.25 mm

Cylinder head bolts

Maximum dimensions of visible corrosion or pitting 1 cm²
 Maximum pitting depth 0.12 mm

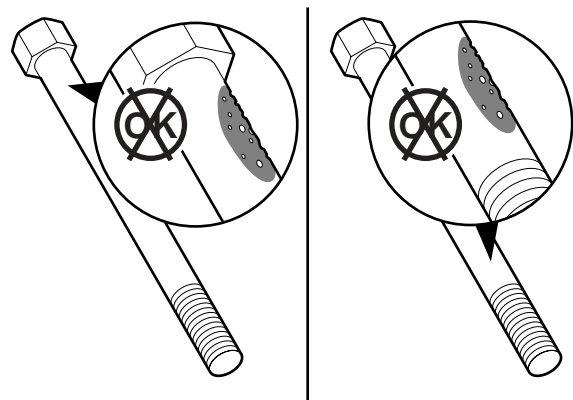

M201249



Length of area below bolt head and just above beginning of screw thread where corrosion or pitting is not allowed (A)

3.2 mm

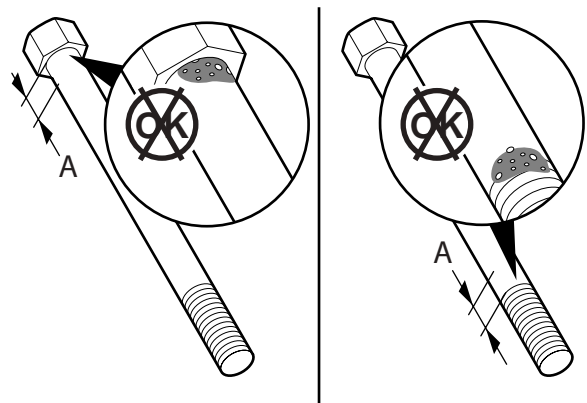

M201250

Maximum free length of short cylinder head bolt (130 mm nominal)

132.1 mm

Maximum free length of long cylinder head bolt (150 mm nominal)

152.1 mm

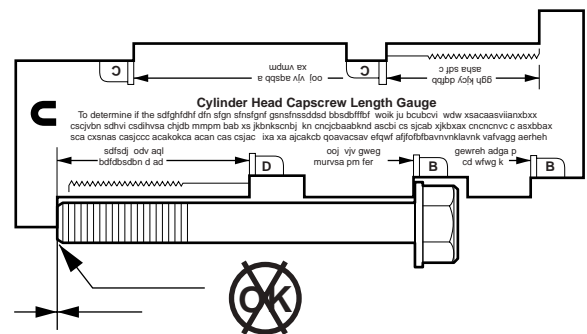

M201252

Valve clearance

Inspection dimension, cold valve clearance

Intake

0.15 - 0.40 mm

Exhaust

0.40 - 0.75 mm

Setting dimension, valve clearance (cold)

Intake

0.25 mm

Exhaust

0.50 mm

Timing gear

Fit the timing gear case using sealant

Loctite Ultra Grey

Front engine panel

Fit front engine panel using sealant

Loctite Ultra Grey

Gear backlash

Crankshaft gear - camshaft gear

0.076 - 0.28 mm

Oil pump gear - idler gear

0.250 - 0.30 mm

End float

Crankshaft end float

0.267 ± 0.165 mm

Camshaft end play

0.230 ± 0.130 mm

Oil sump pressure

New engine

60 - 80 l/min.

Worn engine

180 l/min.

0

Oil sump pressure conversion table	
Inches (water)	Litres per minute (l/min.)
1	50
2	84
3	103
4	119
5	133
6	145
7	155
8	164
9	172
10	180
11	187
12	193
13	200
14	206
15	211
16	217
17	222
18	226
19	229
20	232

Flywheel/starter ring gear

Radial run-out,
measured on the
inside of the flywheel
outer edge (A).

max. 0.127 mm

Axial deviation,
measured on the
flywheel outer edge
(B).

max. 0.406 mm

Heat starter ring gear
(max. 20 min.)

max. 125°C

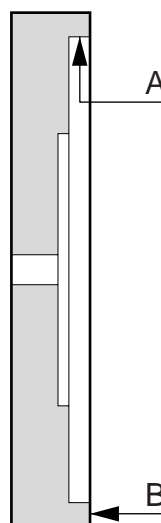

M201199

Flywheel housing

Fit flywheel housing using sealant

Loctite 5205

Vibration damper

Difference in thickness at 4 places must not
exceed:

6.35 mm

4.2 TIGHTENING TORQUES

The tightening torques stated in this section are different from the standard tightening torques stated in the overview of the standard tightening torques. The other threaded connections not specified must therefore be tightened to the torque stated in the overview of standard tightening torques.

When attachment bolts and nuts are replaced, it is important that - unless stated otherwise - these bolts and nuts are of exactly the same length and property class as those removed.

Starter motor

Attachment bolts 43 Nm

Automatic poly-V-belt tensioner

Attachment bolts 43 Nm

Alternator

Alternator bracket attachment bolts 30 Nm

Alternator attachment bolts 60 Nm

Pulley attachment nut 80 Nm

Air compressor

Compressor attachment nuts 80 Nm

Pipe attachments 39 Nm

Steering pump

Attachment bolts, steering pump 55 Nm

Line connection in the pump, delivery side 36 Nm

Attachment bolts, cover 20 Nm

Attachment bolts, reservoir 8 Nm

Air-conditioning compressor

Compressor support attachment bolts 30 Nm

Compressor attachment bolts 60 Nm

Valve gear

Rocker setting bolt lock nut 24 Nm

Valve sleeve attachment bolts 24 Nm

Valve cover attachment bolts 10 Nm

Rocker seat attachment bolts 36 Nm

Injector wiring 1 Nm

Intake manifold

Intake manifold attachment bolts	24 Nm
Fuel rail attachment bolts	24 Nm
Glow element attachment bolts	14 Nm
Air inlet hose clamps	7 Nm

Exhaust manifold

Attachment bolts	43 Nm ⁽¹⁾
Heat shields	56 - 64 Nm

(1) Tighten crosswise from inside to outside.

Cylinder head**Note:**

Apply a drop of engine oil on the thread of the attachment bolts and under the bearing surface of the bolt heads.

Phase 1

All attachment bolts 35 Nm ⁽¹⁾

(1) Tighten the bolts in the order indicated

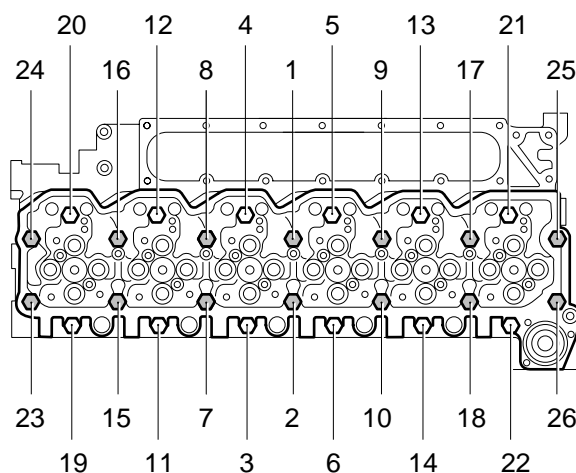

M201143

Phase 2

Use **only** attachment bolts that are 150 mm in length 55 Nm ⁽¹⁾

(1) Tighten the bolts in the order indicated

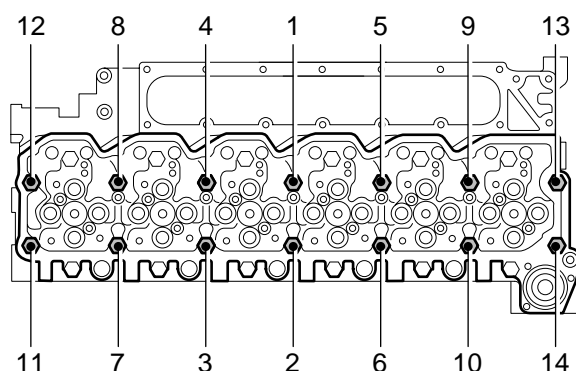

M201202

0

Phase 3

All attachment bolts

2 steps of 90° angular displacement each ⁽¹⁾

(1) Tighten the bolts in the order indicated

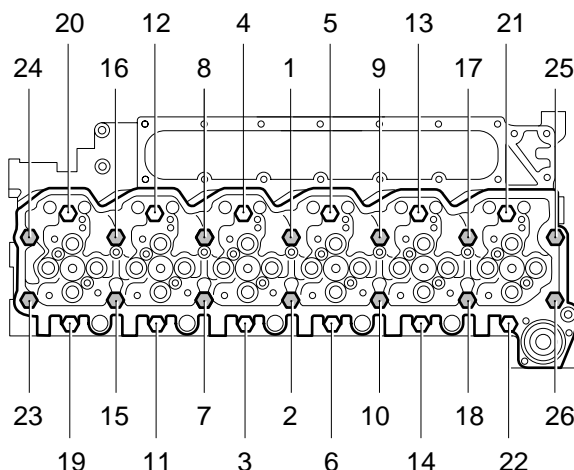

M201143

Vibration damper

Attachment bolts

1st phase

2nd phase

50 Nm

90° angular displacement

Timing gear

Camshaft locking plate attachment bolts

M8 attachment bolts for timing gear case

M10 attachment bolts for timing gear case

M12 attachment bolts for timing gear case

Camshaft gear attachment bolts

24 Nm

24 Nm

47 Nm

50 Nm

36 Nm

Front engine panel

Front engine panel

attachment bolts

24 Nm ⁽¹⁾

(1) Tighten the attachment bolts in the order indicated

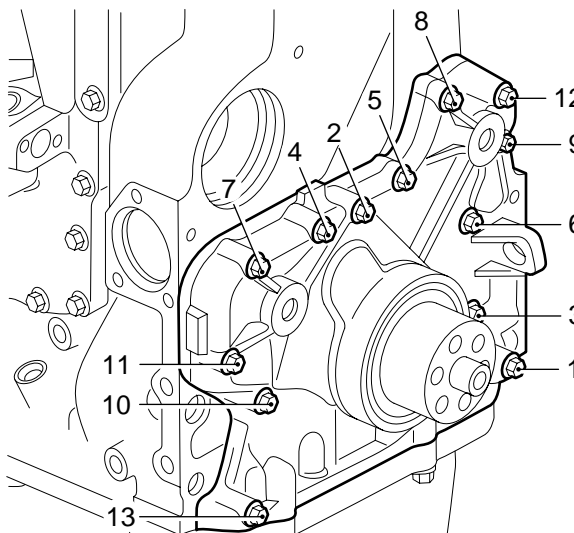

M201144

Flywheel

Attachment bolts

30 Nm + 60° angular displacement

Flywheel housing

M10 attachment bolts	49 Nm ⁽¹⁾
M12 attachment bolts	85 Nm ⁽¹⁾

(1) Tighten the attachment bolts in the order indicated

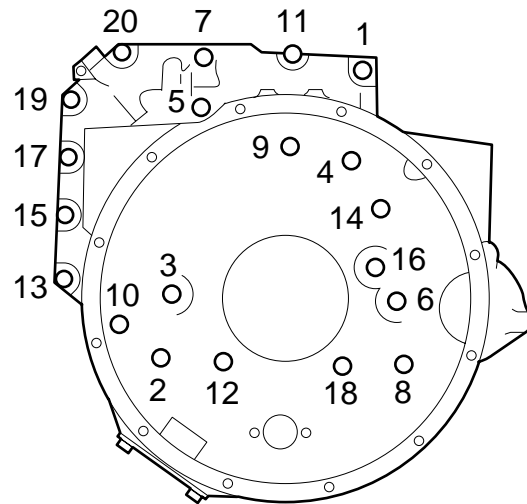

M201080

Engine mounting, front

Engine bracket attachment bolts/nuts 110 Nm

Engine mounting, rear

Bolts attaching engine bracket to chassis	110 Nm + 90° angular displacement
Bolts attaching engine bracket to engine	110 Nm + 60° angular displacement
Bolts attaching support to engine bracket	170 Nm + 90° angular displacement

Engine hanger brackets

Front engine hanger bracket attachment bolts	77 Nm
Rear engine hanger bracket attachment bolts	43 Nm

5. CE ENGINE COOLING SYSTEM

5.1 GENERAL

Thermostat

Thermostat opening temperatures:

thermostat opens at

approx. 81°C

thermostat fully open at

approx. 94°C

Full thermostat opening at

14.3 mm

Header tank pressure cap

Pressure relief valve opening pressure

approx. 0.75 bar

Vacuum relief valve opening pressure

approx. 0.1 bar

Pressure-testing cooling system

Test pressure

0.5 - 0.7 bar

Cleaning cooling system

Product name	Properties	Applications	DAF number
RP cleaner	Cleaning time 45 min. with engine running	Cleaning cooling system	1334996

0

5.2 TIGHTENING TORQUES

The tightening torques stated in this section are different from the standard tightening torques stated in the overview of the standard tightening torques. The other threaded connections not specified must therefore be tightened to the torque stated in the overview of standard tightening torques.

When attachment bolts and nuts are replaced, it is important that - unless stated otherwise - these bolts and nuts are of exactly the same length and property class as those removed.

Coolant pump

Attachment bolts 24 Nm

Thermostat housing

Attachment bolts 10 Nm

Radiator

Attachment nuts 89 Nm

5.3 FILLING CAPACITIES

Cooling system capacity approx. 22 litres

6. CE ENGINE LUBRICATION SYSTEM

6.1 GENERAL

Oil pressure

Lubricating oil pressure at engine idling speed	min. 0.69 bar
Lubricating oil pressure at full-load engine speed	min. 2.07 bar
Bypass pressure regulator opening pressure	3.52 bar

Oil filter

Type	disposable filter
Number	1
Location in the oil circuit	full flow

Oil cooler

Oil cooler pressure test temperature	approx. 60°C
Oil section test pressure	4.5 - 5.0 bar
Opening pressure of bypass valve at a pressure difference of	3.45 bar

Lubricating oil pump

Maximum clearance, inner rotor - outer rotor	0.178 mm
--	----------

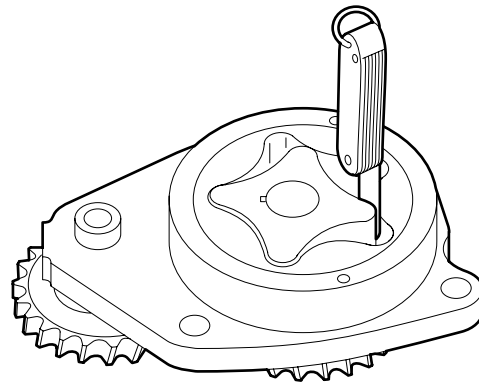

M201077

Maximum clearance, outer rotor - pump housing	0.381 mm
---	----------

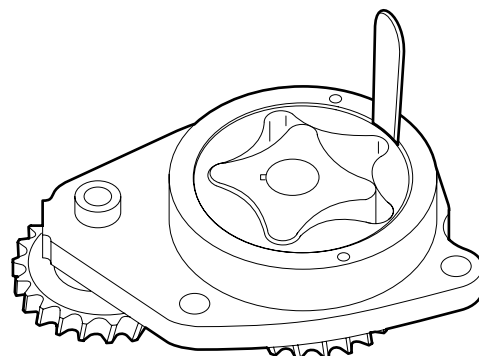

M201076

0

Maximum clearance of inner and outer rotor relative to the pump housing, measured with a straight edge

0.127 mm

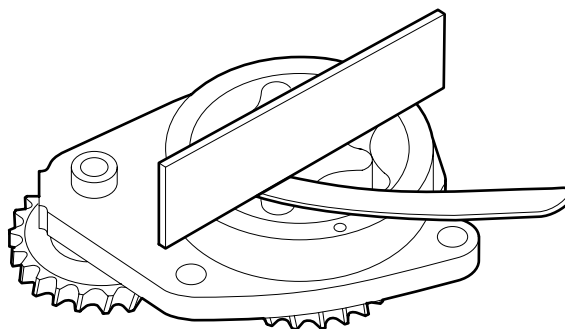

M201075

Lubricating oil pump gear backlash

Lubricating oil pump idler gear - lubricating oil pump gear

0.25 - 0.30 mm

Crankshaft gear - lubricating oil pump idler gear

0.15 - 0.25 mm

Crankshaft gear - lubricating oil pump gear

0.30 - 0.50 mm

Oil consumption

Maximum permissible engine oil consumption

0.5% of the average fuel consumption

Example:

Average measured fuel consumption:

25 litres/100 km = 250 litres/1000 km

Maximum permissible engine oil consumption:

0.5% x 250 = 1.25 litres/1000 km

- Engine oil consumption of 1.25 litres / 1000 km is permissible
- Engine oil consumption > 1.25 litres / 1000 km; check the engine using the diagnostics table. See "Diagnostics".

6.2 TIGHTENING TORQUES

The tightening torques stated in this section are different from the standard tightening torques stated in the overview of the standard tightening torques. The other threaded connections not specified must therefore be tightened to the torque stated in the overview of standard tightening torques.

When attachment bolts and nuts are replaced, it is important that - unless stated otherwise - these bolts and nuts are of exactly the same length and property class as those removed.

Oil filter

Attachment bolts to connect filter head to engine block

24 Nm

Oil sump

Oil sump attachment bolts

24 Nm ⁽¹⁾

Oil drain plug

60 Nm

(1) Tighten the attachment bolts in the order indicated

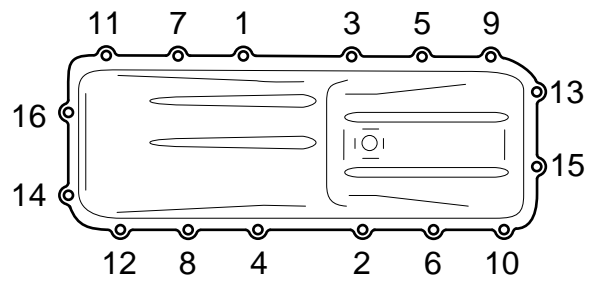

M201079

Oil cooler

Attachment bolts connecting oil cooler to cylinder block

24 Nm ⁽¹⁾

(1) Tighten the attachment bolts in the order indicated

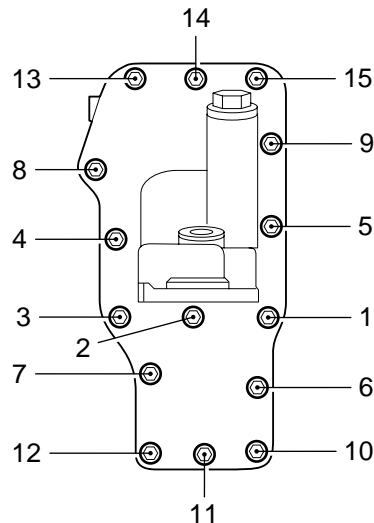

M201145

0**Oil pump**

Attachment bolts 24 Nm

Turbocharger oil supply pipe

Union on filter head 24 Nm

Union on turbocharger 28 Nm

6.3 FILLING CAPACITIES**Lubrication system**

Total capacity, including oil cooler and oil filter 19.5 litres

Oil sump capacity, maximum level 17.5 litres

Oil sump capacity, minimum level 15.5 litres

CONTENTS

	Page	Date
1. TRACTIVE PROBLEMS	1-1.....	200505
1.1 Introduction	1-1.....	200505
1.2 Acceleration test	1-2.....	200505
1.3 Acceleration test form	1-4.....	200505
1.4 Acceleration test using DAVIE	1-5.....	200505
2. BE/CE ENGINE, GENERAL	2-1.....	200505
2.1 Introduction	2-1.....	200505
2.2 Fault-finding table, engine functions	2-2.....	200505
2.3 Fault-finding table, vehicle functions	2-6.....	200505
3. BE/CE ENGINE COOLING SYSTEM	3-1.....	200505
3.1 Introduction	3-1.....	200505
3.2 Fault-finding table	3-2.....	200505
4. BE/CE ENGINE LUBRICATION SYSTEM	4-1.....	200505
4.1 Introduction	4-1.....	200505
4.2 Fault-finding table	4-2.....	200505

1. TRACTIVE PROBLEMS

1.1 INTRODUCTION

There may be many reasons why a vehicle's performance is below standard.

Some of these may be mechanical, but some may be psychological in nature. It is therefore important to identify the problem properly.

Try to get as much information as possible from the customer or driver.

- When does the vehicle not perform properly?
- What are the road or weather conditions when this occurs?
- What are the vehicle's loading conditions?
- Is the vehicle not being compared with a vehicle with completely different specifications, for instance engine power?
- Is the vehicle being driven in the correct engine speed range?

If the answers are unsatisfactory, ask the customer or driver for facts.

- Tachograph cards of trips
- Reliable consumption figures of trips

Following correct identification of the complaint, vehicle performance can be tested by an acceleration test.

If the vehicle fails to pass the acceleration test, a boost pressure curve may be plotted as an aid to identifying the cause.

Note:

Checking the boost pressure will in general only make sense after the vehicle has covered at least 20,000 km.

1.2 ACCELERATION TEST

1. Use the "Acceleration test form", which is included in the Workshop Manual.
2. Do the checks set out under "Before starting the acceleration test".

Note:

The work described depends on the type of engine and vehicle.

3. Establish a test route where the difference between the measured times in both directions does not exceed 15%. If the difference in time exceeds 15%, find another test route.
4. Establish the starting and end points on the selected test route, to ensure that exactly the same route can be taken in both directions. Do the entire test at least twice and take the average time.
5. Run the drive train at operating temperature (drive for at least 15 minutes with a loaded vehicle).

Note:

When switched on, the air compressor, air-conditioning compressor and fan consume 10 to 15 kW engine power on average. During the test try to avoid these consumers being switched on.

6. Connect DAVIE and follow the instructions given.
7. Fully depress the accelerator pedal during the acceleration test.

Result of first acceleration test

If the acceleration time is not achieved, first carry out the following work.

- Check the fuel system for the presence of air.
- Replace or clean the air filter element.
- Check the adjustment of the wastegate on the turbocharger.
- Check the exhaust brake butterfly valve for correct operation.
- Check the charge cooler exterior for dirt deposits.
- Clean the water separator.
- Check that the primer pump is attached.
- Replace the fuel fine filter.
- Check the suction pipe of the tank for clogging by coarse dirt.
- Check the fuel suction line for clogging and flow resistance.
- Check the fuel tank for fouling. Clean with a steam cleaner, if necessary.
- Check the air intake system for any leaks.
- Check the exhaust system for any leaks.
- Check the exhaust system for blockages by measuring the exhaust gas back pressure.
- Check the turbocharger impellers on the compressor and turbine sides for damage and for deposits of salt or any other contaminants.
- Check both the valve clearance and the DEB clearance.
- Check the injector pipes for damage.
- Check the fuel gallery/rail pressure.
- Check the fuel lift pump output.
- Check whether the right type of components has been fitted. This includes turbocharger, injectors, etc.
- Check the opening pressure of the injectors.

Repeat the acceleration test. If necessary, plot a boost pressure curve.

1.3 ACCELERATION TEST FORM**General data**

Customer's name: _____

Chassis number: _____

Registration number: _____

Test conditions

Weather conditions: dry / rain / wet road / drizzle

Wind force: none / average / strong

Outside temperature: _____ °C

Vehicle data

Vehicle type: _____ Trailer type: _____ Superstructure: _____

Total combination weight: _____ kg Total vehicle height: _____ m

Cab type: day / sleeper / space / superspace

Aerodynamics: roof spoiler / fenders / front spoiler / skirts / sun visor / _____

Engine type: _____ Gearbox type: _____ Transmission: _____

Rear axle type: _____ Transmission: _____

Tyre size: front: _____ rear: _____

Tyre make: _____ Energy: _____

Space between cab and superstructure/trailer: _____ m

TOPEC data

Starting speed: _____ km/h End speed: _____ km/h

Gear selection: _____ Acceleration time: _____ sec.

Measured time of outward journey: 1: _____ sec.

2: _____ sec.

3: _____ sec.

Average time of outward journey: _____ sec.

Average time: _____ sec.

Measured time of return journey: 1: _____ sec.

2: _____ sec.

3: _____ sec.

Average return time: _____ sec.

1.4 ACCELERATION TEST USING DAVIE

The acceleration test can also be carried out using DAVIE. Collect the necessary data and, after starting DAVIE, go to the engine management system and carefully follow the instructions in DAVIE for carrying out the test correctly.

The test results should be saved to diskette after each test.



The acceleration test in DAVIE should only be started when the vehicle is stationary. As the communication between the accelerator pedal sensor and the unit will be broken for a short time when DAVIE is started up, this can lead to dangerous situations when the vehicle is being driven.

When driving, never start a "direct test" or "guide diagnosis".

2. BE/CE ENGINE, GENERAL

2.1 INTRODUCTION

If there is a fault in the system, it is usually detected by the electronic unit in the form of a fault code. This fault code can be read out using DAVIE. The fault-finding table contains possible causes of symptoms not detected by the electronic unit.

2.2 FAULT-FINDING TABLE, ENGINE FUNCTIONS

1

SYMPTOM: ENGINE CAN BE STARTED, BUT DOES NOT RUN	
Possible cause	Remedy
Poor fuel quality	Drain fuel, flush fuel system, replace the fuel filters and fill fuel tank with fuel
Air in fuel system	Check for drawing in of air: <ul style="list-style-type: none"> - via the suction pipe - via the fuel lift pump seal
Fuel filter clogged	Replace the fuel filter and clean the system
While carrying out an engine test with DAVIE, communication with DAVIE was interrupted	Remove the battery earth lead and then refit it
No fuel supply/fuel lift pump defective; no delivery	Check: <ul style="list-style-type: none"> - the fuel level - the pipes for blockage and leaks - the fuel lift pump

SYMPTOM: ENGINE STALLS AND RUNS AGAIN AFTER RE-STARTING	
Possible cause	Remedy
Air in fuel system	Check for drawing in of air: <ul style="list-style-type: none"> - via the suction pipe - via the fuel lift pump seal

SYMPTOM: ENGINE STARTS POORLY	
Possible cause	Remedy
Poor fuel quality	Drain fuel, flush fuel system, replace the fuel filters and fill fuel tank with fuel
Air in fuel system	Check for drawing in of air: <ul style="list-style-type: none"> - via the suction pipe - via the fuel lift pump seal
Fuel filter clogged	Replace the fuel filter and clean the system
Battery voltage too low	Charge the batteries
Mechanical defect or clogging in injector	Replace the injector
Fuel lift pump delivery too low	Check the fuel lift pump and replace if necessary
Internal leakage between the fuel supply pipe and the injector	Check the fuel supply pipe/injector connections for internal leaks

SYMPTOM: ENGINE RUNS AT (INCREASED) IDLING SPEED AND DOES NOT RESPOND TO ACCELERATOR PEDAL	
Possible cause	Remedy
Mechanical defect of accelerator pedal sensor	Check: <ul style="list-style-type: none"> - the mechanical connection between the sensor and the accelerator pedal - the accelerator pedal sensor
Fuel quantity adjustment by ABS/ASR	
Engine brake input signal present	Check the electrical system of the engine brake

SYMPTOM: DIESEL KNOCK DURING ACCELERATION	
Possible cause	Remedy
Poor fuel quality	Drain fuel, flush fuel system, replace the fuel filters and fill fuel tank with fuel
Air in fuel system	Check for drawing in of air: <ul style="list-style-type: none"> - via the suction pipe - via the fuel lift pump seal
Injector defective	Inspect the injectors

SYMPTOM: IRREGULAR RUNNING OF ENGINE	
Possible cause	Remedy
Poor fuel quality	Drain fuel, flush fuel system, replace the fuel filters and fill fuel tank with fuel
Air in fuel system	Check for drawing in of air: <ul style="list-style-type: none"> - via the suction pipe - via the fuel lift pump seal
Fuel filter clogged	Replace the fuel filter
Connection points on injectors mixed up	Connect the correct connection points to the correct injector
Mechanical defect or clogging in injectors	Replace the injectors
Injector defective	Inspect the injectors
Fuel lift pump delivery too low	Check the fuel lift pump and replace if necessary
Pressure relief valve on fuel rail does not shut off	Check the pressure relief valve

1

SYMPTOM: REDUCED POWER AT ALL ENGINE SPEEDS	
Possible cause	Remedy
Poor fuel quality	Drain fuel, flush fuel system, replace the fuel filters and fill fuel tank with fuel
Fuel filter clogged	Replace the fuel filter
Mechanical defect of accelerator pedal sensor	Check: - the mechanical connection between the sensor and the accelerator pedal - the accelerator pedal sensor
Fault in electrical components/wiring of: - contacts - contact resistors in connector contacts	Check the electrical system
Air filter clogged	Replace or clean the air filter
Turbocharger defective/wastegate control incorrect	Check the turbocharger/wastegate control
Air leak in inlet system	Pressure-test the inlet system
Mechanical defect or clogging in injectors	Replace the injectors
Fuel lift pump delivery too low	Check the fuel lift pump and replace if necessary

SYMPTOM: REDUCED POWER ABOVE A CERTAIN ENGINE SPEED	
Possible cause	Remedy
Fuel filter partially clogged	Replace the fuel filter
Air filter partially clogged.	Replace or clean the air filter
Air leak in inlet system	Pressure-test the inlet system
Fuel lift pump delivery too low	Check the fuel lift pump and replace if necessary

SYMPTOM: WHITE/BLUE SMOKE IS EMITTED	
Possible cause	Remedy
Poor fuel quality	Drain fuel, flush fuel system, replace the fuel filters and fill fuel tank with fuel
Air in fuel system	Check for drawing in of air: - via the suction pipe - via the fuel lift pump seal
Fuel filter clogged	Replace the fuel filter and clean the system
Mechanical defect or clogging in injectors	Replace the injectors
Injector defective	Inspect the injectors
Fuel lift pump delivery too low	Check the fuel lift pump and replace if necessary

SYMPTOM: BLACK SMOKE IS EMITTED	
Possible cause	Remedy
Injector defective	Inspect the injectors

SYMPTOM: FUEL CONSUMPTION TOO HIGH	
Possible cause	Remedy
Poor fuel quality	Drain fuel, flush fuel system, replace the fuel filters and fill fuel tank with fuel
Fuel filter clogged	Replace the fuel filter and clean the system
Air leak in inlet system	Pressure-test the inlet system
Mechanical defect or clogging in injectors	Replace the injectors
Leak in fuel system	Check for leaks

SYMPTOM: REDUCED MAXIMUM ENGINE SPEED	
Possible cause	Remedy
Air in fuel system	Check for drawing in of air: - via the suction pipe - via the fuel lift pump seal
Fuel filter clogged	Replace the fuel filter and clean the system
Turbocharger defective	Check turbocharger
Mechanical defect or clogging in injectors	Replace the injectors
Fuel quantity adjustment by ABS/ASR	
Fuel lift pump delivery too low	Check the fuel lift pump and replace if necessary

2.3 FAULT-FINDING TABLE, VEHICLE FUNCTIONS

1

SYMPTOM: VEHICLE SPEED CONTROL DOES NOT WORK	
Possible cause	Remedy
Fault in electrical components/wiring of: <ul style="list-style-type: none"> - steering column switch - proximity switch 	Check the electrical system
Condition(s) for disengaging vehicle speed control present	Check for presence of disengaging condition(s)

SYMPTOM: ENGINE SPEED CONTROL DOES NOT WORK	
Possible cause	Remedy
Condition(s) for disengaging engine speed control present	Check for presence of disengaging condition(s)
Fault in electrical components/wiring of: <ul style="list-style-type: none"> - wiring harness - steering column switch 	Check the electrical system

SYMPTOM: PRE-GLOWING AND AFTER-GLOWING FUNCTION DOES NOT WORK	
Possible cause	Remedy
Fault in electrical components/wiring of: <ul style="list-style-type: none"> - wiring harness - warning lamp, pre-glowing - glow element - relay, glow element 	Check the electrical system

SYMPTOM: ENGINE CANNOT BE SWITCHED OFF WITH IGNITION KEY	
Possible cause	Remedy
Power supply to electronic unit not cut off. Power supply to electronic unit after contact not cut off with contact switch.	Check the electrical system

SYMPTOM: FAULT INDICATOR LAMP DOES NOT GO ON OR DOES NOT GO OFF	
Possible cause	Remedy
Fault in electrical components/wiring of: <ul style="list-style-type: none"> - wiring harness - electronic unit 	Check the electrical system

SYMPTOM: NO COMMUNICATION POSSIBLE WITH DAVIE	
Possible cause	Remedy
Fault in electrical components/wiring of: <ul style="list-style-type: none">- wiring harness- diagnostic connector Power supply to electronic unit after contact not cut off with contact switch. No supply voltage to the electronic unit Electronic unit defective	Check the electrical system

3. BE/CE ENGINE COOLING SYSTEM

3.1 INTRODUCTION

If there is a fault in the system, it is usually detected by the electronic unit in the form of a fault code. This fault code can be read out using DAVIE. The fault-finding table contains possible causes of symptoms not detected by the electronic unit.

3.2 FAULT-FINDING TABLE

SYMPTOM: ENGINE TEMPERATURE INCREASES	
Possible cause	Remedy
Incorrect injectors installed	Check whether the correct injectors have been installed
Inlet system failure	Check the inlet system
Lubrication system failure	Check the lubrication system
Incorrect poly-V-belt tension	Check the poly-V-belt tensioner or replace the poly-V-belt
Insufficient coolant	Check the coolant level. Top up if necessary
Coolant hose torn or clogged	Check the coolant hoses
Air cooler and cooling system radiator fouled	Check/clean the air cooler and cooling system radiator
Wastegate setting is too high	Check the wastegate setting
Air hose from the turbocharger housing to the wastegate diaphragm leaks or is not connected	Check the air hose. Replace if necessary.
Incorrect or malfunctioning pressure cap	Check the pressure cap
Thermostat opens insufficiently or not at all	Check the thermostat and its operation
Coolant pump defective	Check the coolant pump shaft, bearings and impeller. Replace the coolant pump if necessary
Viscous fan defective	Check operation of the viscous fan
Poor fuel quality	Drain fuel, flush fuel system, replace the fuel filters and fill fuel tank with fuel

SYMPTOM: EXTERNAL COOLANT LEAKAGE	
Possible cause	Remedy
Coolant hoses defective	Check the coolant hoses
Coolant pipes defective	Check the coolant pipes
Radiator leaking	Check the radiator. Pressure-test if necessary
Coolant pump leaking	Check coolant pump. If necessary, measure bearing play
Defective oil cooler	Inspect the oil cooler. Pressure-test if necessary
Defective pressure cap	Check the pressure cap. Pressure-test if necessary
Heater leaking	Check the heater hoses

SYMPTOM: INTERNAL COOLANT LEAKAGE	
Possible cause	Remedy
Defective cylinder head gasket	Check the cylinder head gasket
Cracked cylinder head or cylinder block	Check the cylinder head and cylinder block for internal cracks. Pressure-test if necessary
Defective compressor cylinder head gasket	Replace the compressor cylinder head gasket
Defective oil cooler	Check whether there is coolant in the lubrication system
Defective expansion plugs in cylinder block or cylinder head	Replace the leaking expansion plug(s)

1

4. BE/CE ENGINE LUBRICATION SYSTEM

4.1 INTRODUCTION

If there is a fault in the system, it is usually detected by the electronic unit in the form of a fault code. This fault code can be read out using DAVIE. The fault-finding table contains possible causes of symptoms not detected by the electronic unit.

4.2 FAULT-FINDING TABLE

1

SYMPTOM: ENGINE OIL PRESSURE TOO LOW	
Possible cause	Remedy
Engine oil level too low	Top up engine oil to maximum level
External oil leaks	Visually check the engine for leaks. Repair if necessary
Engine oil pressure and temperature sensor or engine oil pressure control switch faulty	Check the sensor or switch. Replace if necessary
Oil does not meet the required specifications	Change the engine oil and the oil filter
Oil temperature is too high	Check the oil cooler
Oil mixed with coolant or fuel.	Change the engine oil and the oil filter
Oil suction pipe loose or broken	Check oil pipe. Repair if necessary
Oil pressure control valve fails to operate	Check the oil pressure control valve
Inadequate functioning of oil pump	Check the oil pump
Main or big-end bearings worn out	Check main or big-end bearings
Piston cooler oil nozzle has come loose	Check oil nozzle. Replace if necessary
Fouling between oil pressure control valve and seat	Check/clean the oil pressure control valve
Oil filter fouled	Replace the oil filter

SYMPTOM: ENGINE CONSUMES TOO MUCH OIL	
Possible cause	Remedy
Inlet system failure	Check the inlet system
Exhaust system failure	Check the exhaust system
Oil cooler leaks	Check whether there is lubricating oil in the engine cooling system
Oil temperature is too high	Check that the correct oil cooler has been installed
Excessive blow-by	Check the compression pressure and carry out a cylinder leak test Check the condition of the piston rings and cylinder liners
Worn piston rings and/or cylinder walls	Replace the piston rings and/or drill/hone the cylinders Check the air inlet system Check oil specifications
Turbocharger defective	Check the turbocharger

CONTENTS

	Page	Date
1. SAFETY INSTRUCTIONS	1-1	200505
1.1 Safety instructions	1-1	200505
2. GENERAL	2-1	200505
2.1 Location of components	2-1	200505
2.2 Identification	2-3	200505
2.3 Overview drawing, timing gear	2-4	200505
3. CHECKING AND ADJUSTING	3-1	200505
3.1 Checking and adjusting BE engine valve clearance	3-1	200505
3.2 Checking and adjusting timing gear	3-3	200505
3.3 Checking piston projection	3-5	200505
3.4 Checking cylinder head bolts	3-7	200505
3.5 Inspecting the flywheel	3-9	200505
3.6 Inspection, engine oil sump pressure	3-10	200505
3.7 Inspection, vibration damper	3-11	200505
3.8 Inspecting the cylinder head	3-11	200505
3.9 Inspecting the cylinder block	3-12	200505
4. REMOVING AND INSTALLING	4-1	200505
4.1 Removal and installation, engine	4-1	200505
4.2 Removal and installation, engine mounts	4-2	200505
4.3 Removal and installation, valve cover	4-4	200505
4.4 Removal and installation, valve sleeve	4-5	200505
4.5 Removal and installation, valve gear	4-7	200505
4.6 Removal and installation, intake manifold	4-8	200505
4.7 Removal and installation, exhaust manifold	4-10	200505
4.8 Removing and installing cylinder head	4-11	200505
4.9 Removal and installation, air compressor	4-15	200505
4.10 Removing and installing steering pump	4-16	200505
4.11 Removal and installation, starter motor	4-18	200505
4.12 Removal and installation, poly-V-belt	4-19	200505
4.13 Removal and installation, alternator	4-20	200505
4.14 Removal and installation, flywheel	4-21	200505
4.15 Removal and installation, starter ring gear	4-22	200505
4.16 Removal and installation, flywheel housing seal	4-23	200505
4.17 Removal and installation, flywheel housing	4-24	200505
4.18 Removal and installation, vibration damper	4-25	200505
4.19 Removal and installation, crankshaft sensor ring	4-26	200505
4.20 Removing and installing front engine panel	4-27	200505
4.21 Removal and installation, camshaft gear	4-28	200505
4.22 Removal and installation, timing gear case	4-30	200505
4.23 Removal and installation, front crankshaft seal	4-32	200505
5. CLEANING	5-1	200505
5.1 Cleaning the engine	5-1	200505

1. SAFETY INSTRUCTIONS

1.1 SAFETY INSTRUCTIONS

Fuel



Diesel fuel is an extremely flammable liquid, and must not be exposed to naked flames or come into contact with hot surfaces. The diesel fuel fumes remaining in an empty fuel tank form an extremely explosive mixture.

When fuel system components are being removed, some fuel will escape. To keep this spillage to a minimum, unscrew the tank cap to release any overpressure.

Any spilled fuel must be collected, bearing in mind the risk of fire.

Exhaust gases

Do not run the engine in an enclosed or unventilated area. Make sure exhaust fumes are properly extracted.



Exhaust gases contain carbon monoxide. Carbon monoxide is a deadly colourless and odourless gas, which, when inhaled, deprives the body of oxygen, leading to asphyxiation. Serious carbon monoxide poisoning may result in brain damage or death.

Moving parts

Remain at a safe distance from rotating and/or moving components.

Various fluids

Various oils and lubricants used on the vehicle may constitute a health hazard. This also applies to engine coolant, windscreen washer fluid, refrigerant in air-conditioning systems, battery acid and clutch fluid. So avoid inhaling and direct contact.

Electrical short-circuit

Always disconnect the battery's earth connection during repair or maintenance operations for which the electric power supply is not required.

2. GENERAL

2.1 LOCATION OF COMPONENTS

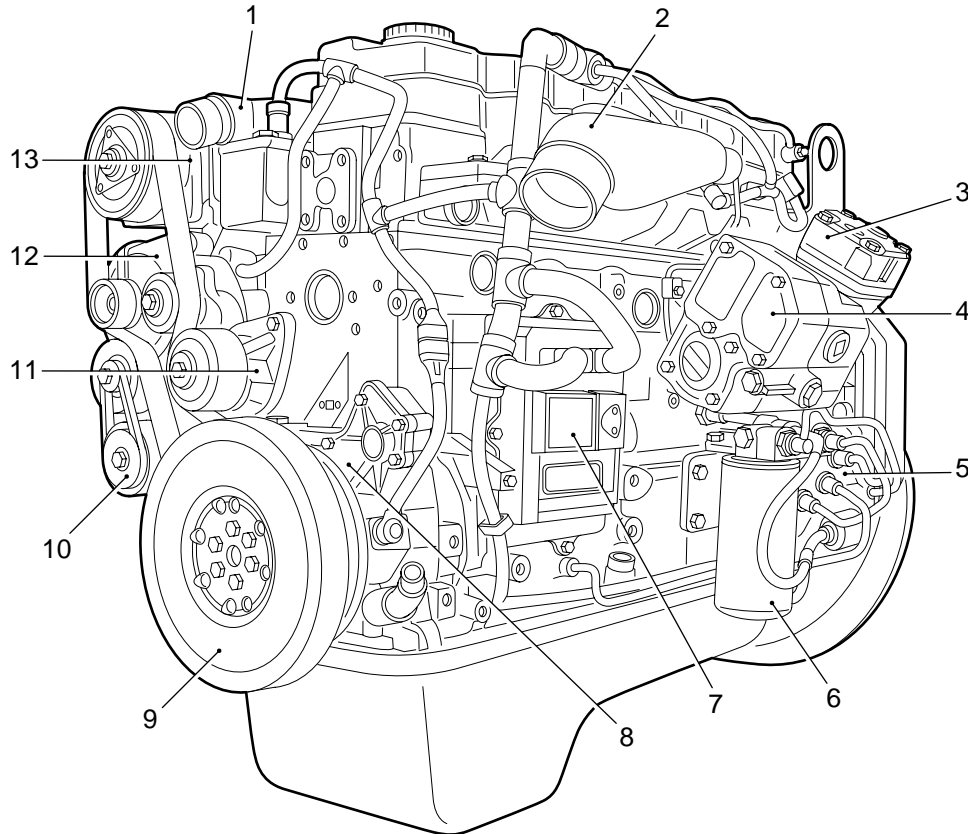

1. Thermostat housing
2. Intake manifold
3. Air compressor
4. Steering pump with reservoir
5. High-pressure pump
6. Fuel filter
7. ECS-DC3 electronic unit
8. Front engine panel
9. Vibration damper
10. Automatic tensioner
11. Coolant pump
12. Alternator
13. Air-conditioning compressor

M201141

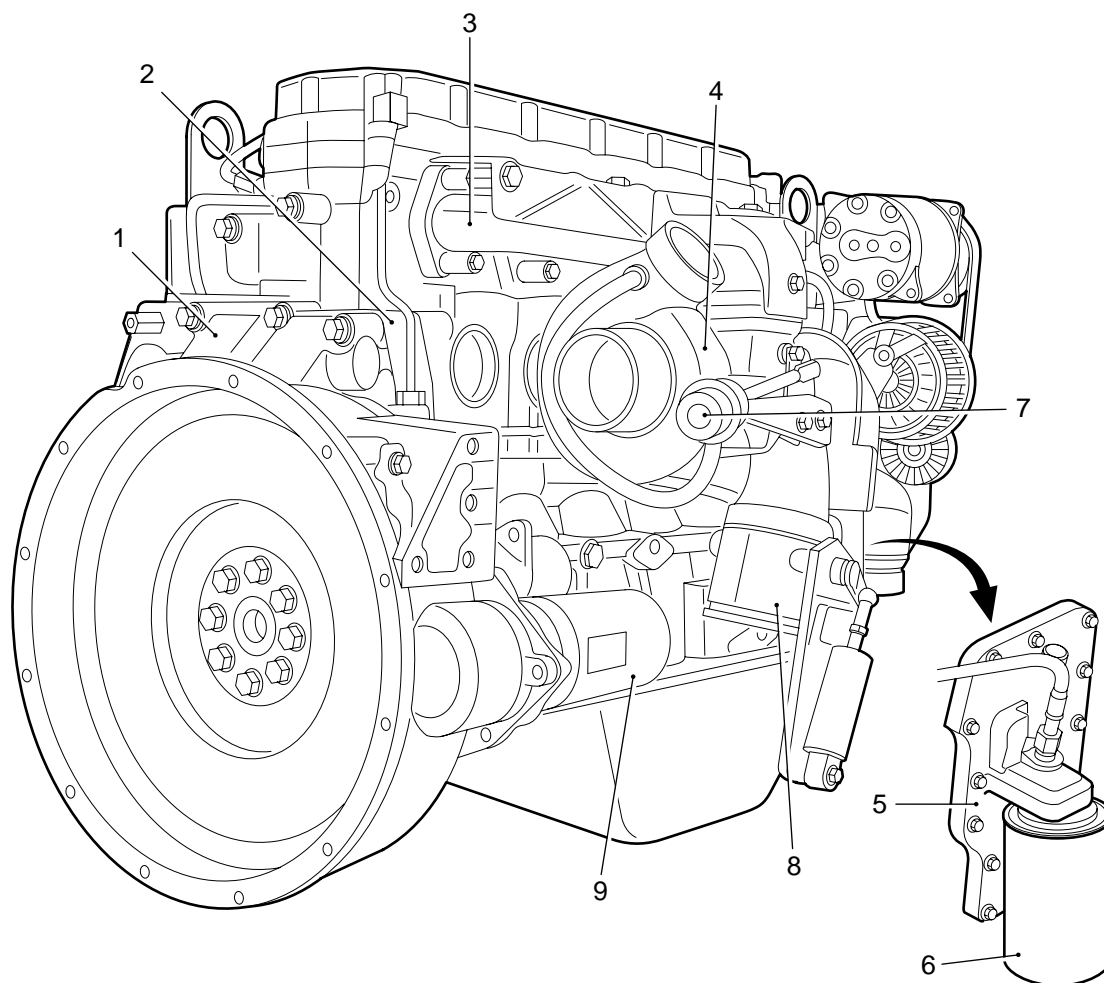

M201140

- 1. Flywheel housing
- 2. Timing gear case
- 3. Exhaust manifold
- 4. Turbocharger
- 5. Oil cooler
- 6. Oil filter
- 7. Wastegate diaphragm
- 8. Exhaust brake
- 9. Starter motor

2.2 IDENTIFICATION

Engine number

The engine number is stamped front right in the cylinder block, at the top of the lubricating oil cooler housing.

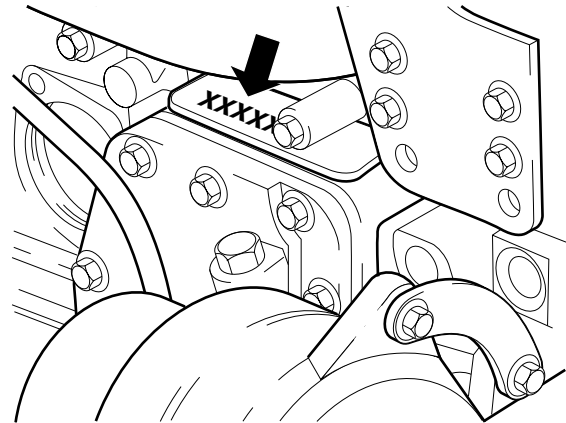

M2 01 138

Engine identification plate

The engine identification plate is located at the top of the flywheel housing or on the valve cover, depending on the production date.

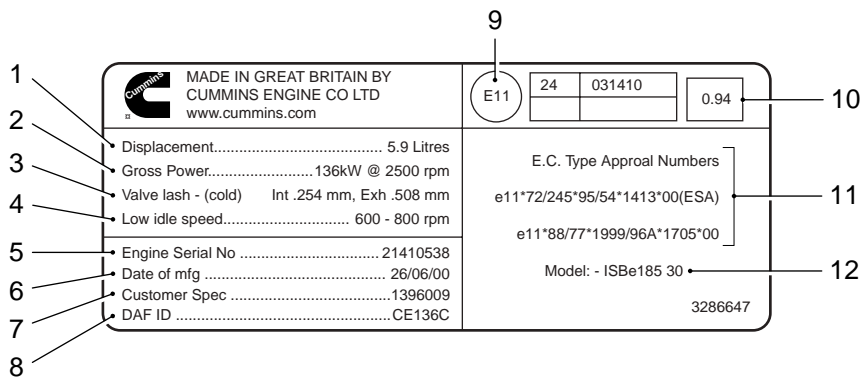

M201135

1. Cubic capacity
2. Engine output
3. Valve clearance
4. Idle engine speed
5. Engine number
6. Production date
7. Client specification
8. DAF type designation
9. Indication of country of origin
10. Free acceleration smoke level (K factor)
11. Type approval numbers
12. Cummins type designation

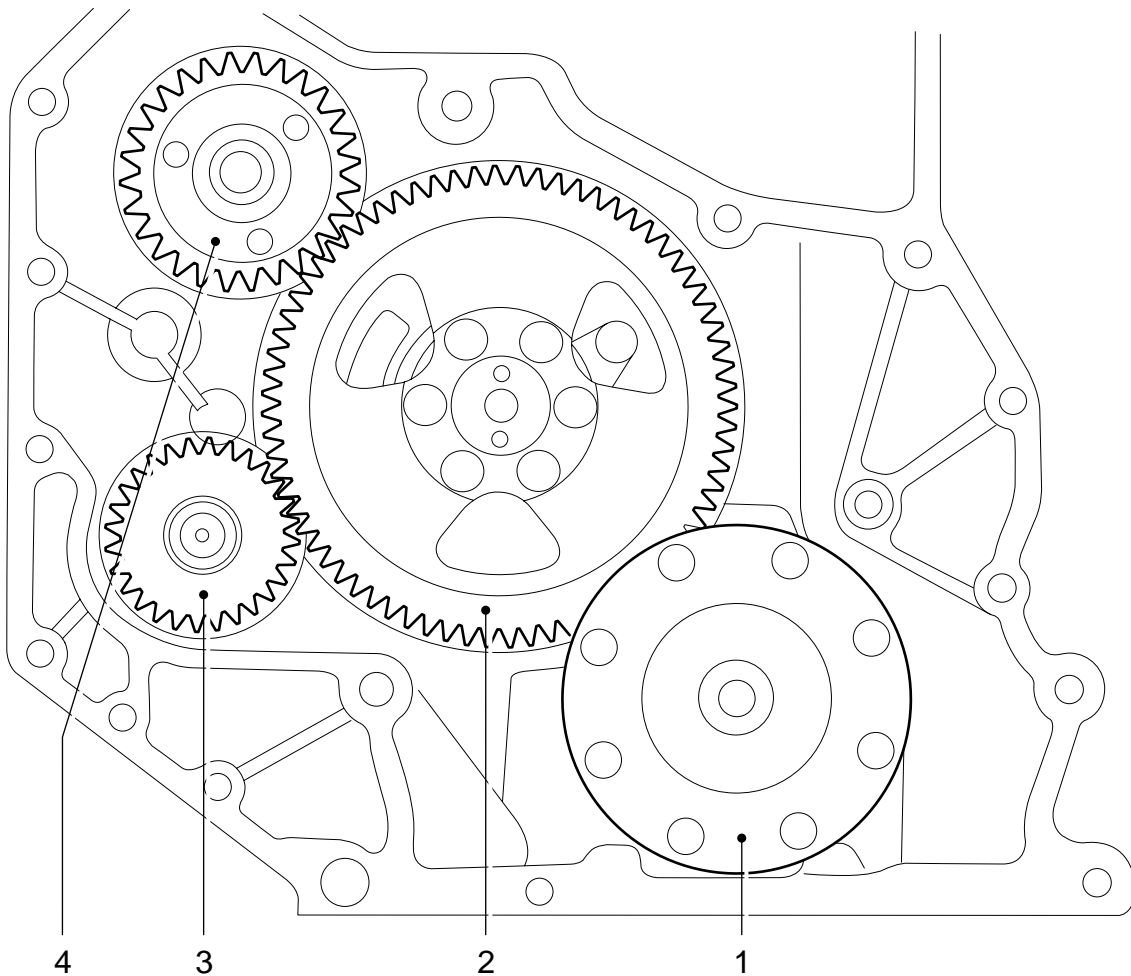
2.3 OVERVIEW DRAWING, TIMING GEAR

1. Crankshaft
2. Camshaft
3. High-pressure pump
4. Compressor

M201432

3. CHECKING AND ADJUSTING

3.1 CHECKING AND ADJUSTING BE ENGINE VALVE CLEARANCE

Note:

Checking and adjusting valve clearance must only be done when the engine is cold.

1. Remove the valve cover. See "Removing and installing".
2. Use an open-end spanner on the fan shaft to turn the crankshaft clockwise, as seen from the vibration damper end (this is the engine's normal direction of rotation), until the mark (A) is between the bolts (B) and the valves of cylinder 1 are in overlap position.

Note:

"Overlap" is the moment at which the inlet valves start opening and the exhaust valves stop closing.

The inlet valves are operated by the short rockers and the exhaust valves by the long rockers.

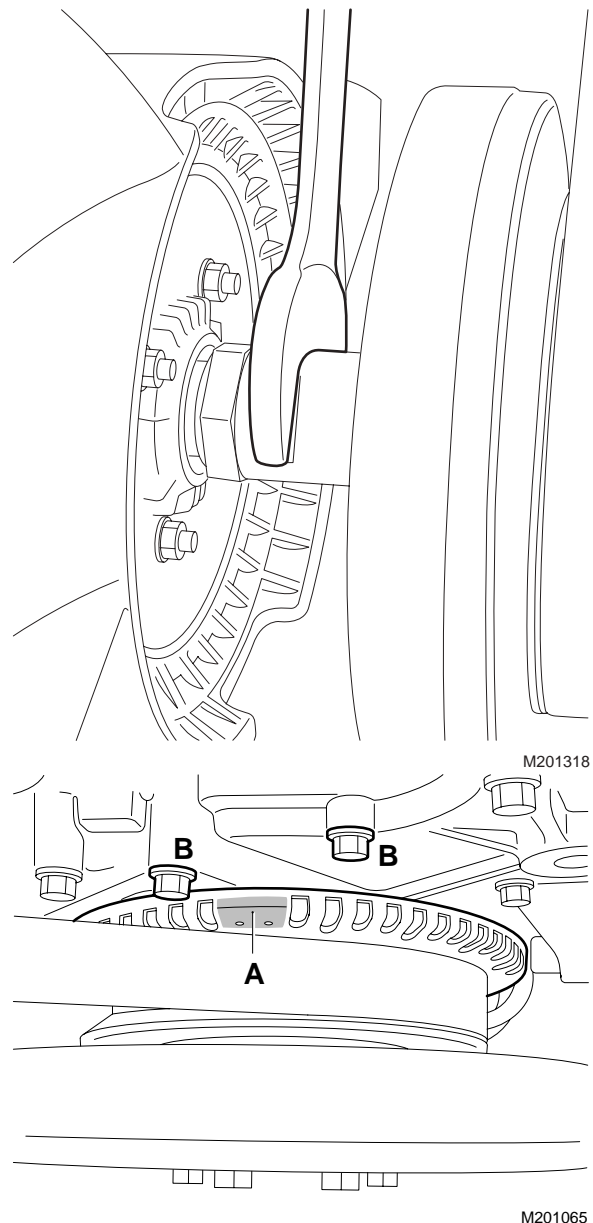

3. Check/correct the valve clearance of the specified inlet and exhaust valves. Set the correct valve clearance by loosening the lock nut and rotating the adjusting screw in the correct direction; see "Technical data" for the correct valve clearance.

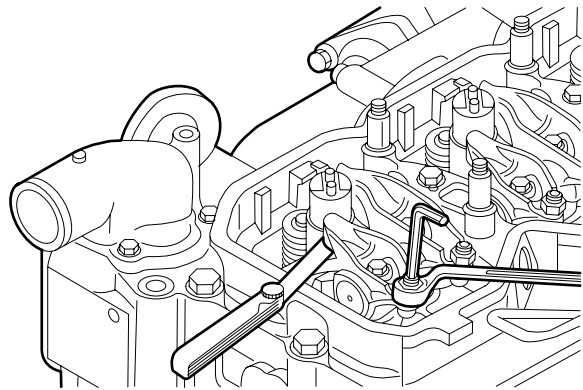

M201064

Cylinder	Inlet valve	Exhaust valve
1		
2		X
3	X	
4	X	X

4. Using an open-end spanner on the fan shaft, turn the crankshaft one rotation further so that the mark (A) is once again between the bolts (B) and the valves of cylinder 4 overlap.
5. Check/correct the valve clearance of the specified inlet and exhaust valves. Set the correct valve clearance by loosening the lock nut and rotating the adjusting screw in the correct direction; see "Technical data" for the correct valve clearance.

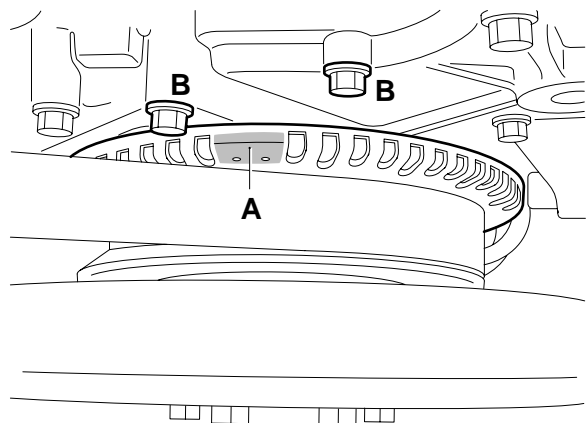

M201065

Cylinder	Inlet valve	Exhaust valve
1	X	X
2	X	
3		X
4		

6. Fit the valve cover. See "Removing and installing".
7. Fit the flexible pipe, air inlet pipe and bracket.

3.2 CHECKING AND ADJUSTING TIMING GEAR

Note:

The engine is fitted with gears on either side. The gears at the vibration damper end only drive the oil pump. These gears have no marks and may be fitted in any position.

The timing gear wheels on the flywheel side drive the camshaft, air compressor and fuel pump. Only the camshaft gear and the crankshaft gear have marks which must be aligned. The other gears may be fitted randomly.

1. Remove the engine encapsulation panels.
2. Remove the gearbox.
3. Remove the flywheel. See "Removing and installing".
4. Remove the flywheel housing. See "Removing and installing".

Note:

When the engine crankshaft or camshaft is turned separately, the pistons and valves may touch each other.

5. Use an open-end spanner on the fan shaft to turn the crankshaft clockwise, as seen from the vibration damper end, until the marks in the crankshaft gear and camshaft gear match. The crankshaft gear has a punched hole in the tooth which has to fall into the tooth depth of the camshaft gear marked with a punched hole.

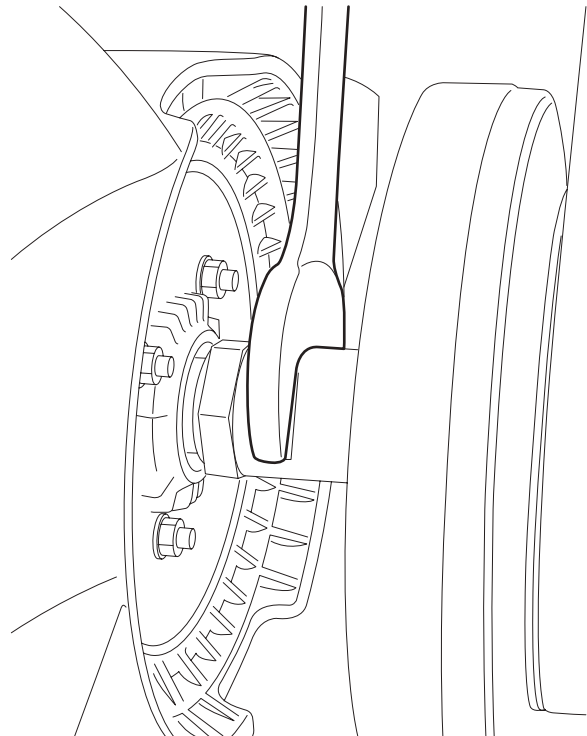

M201318

6. Check that the marked tooth falls exactly into the marked depth. If not, remove and refit the camshaft gear. See "Removing and installing".
7. Fit the flywheel housing. See "Removing and installing".
8. Fit the flywheel. See "Removing and installing".
9. Fit the gearbox.
10. Fit the engine encapsulation panels.

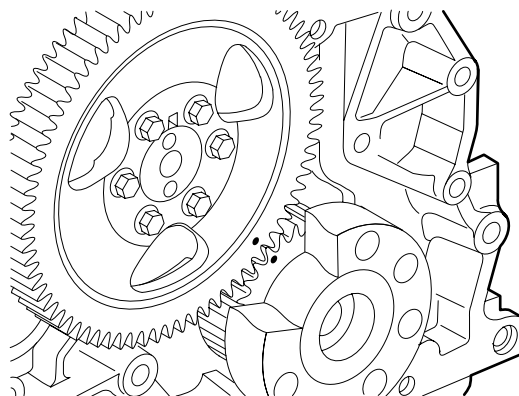

M201146

3.3 CHECKING PISTON PROJECTION

Note:

The piston projection determines which thickness of cylinder head gasket must be used.

1. Use an open-end spanner on the fan shaft to turn the crankshaft, so that the piston of cylinder 1 is in the top dead centre (TDC).
2. Clean the upper surface of the cylinder block and the pistons.

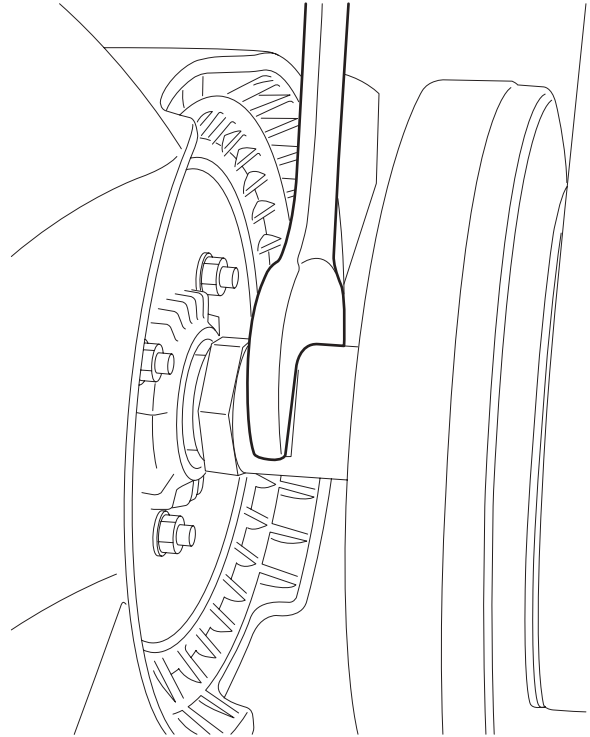

M201318

3. Place a dial gauge on the upper surface of the cylinder block next to cylinder 1 and set the gauge to zero.

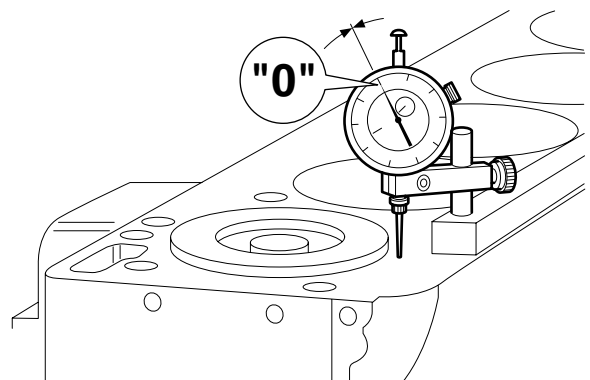

M201233

4. Pull up the stylus of the dial gauge and move it to the edge of the first piston, above the gudgeon pin.
5. Use an open-end spanner on the fan shaft to turn the crankshaft anti-clockwise and clockwise, at the same time reading the dial gauge to find the highest position of the piston. Make a note of this reading.
6. Repeat this measurement for the other pistons.
7. Calculate the average value of the piston projection above the cylinders.

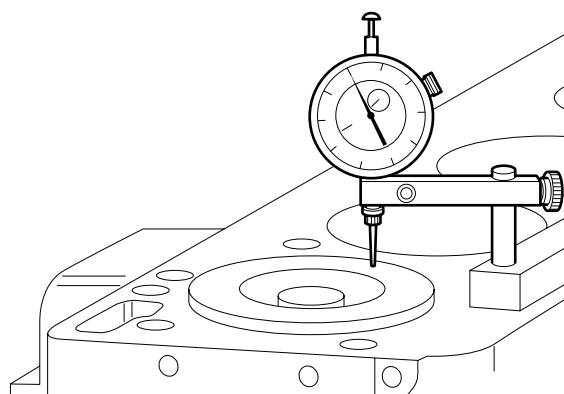

M201234

3.4 CHECKING CYLINDER HEAD BOLTS

Cylinder head bolts can be re-used provided they satisfy a number of conditions. If a cylinder head bolt does not meet one or more of these conditions, new cylinder head bolts must be used.

1. Check cylinder head bolts for damaged screw threads, corroded surfaces and constriction as a result of overstretching.

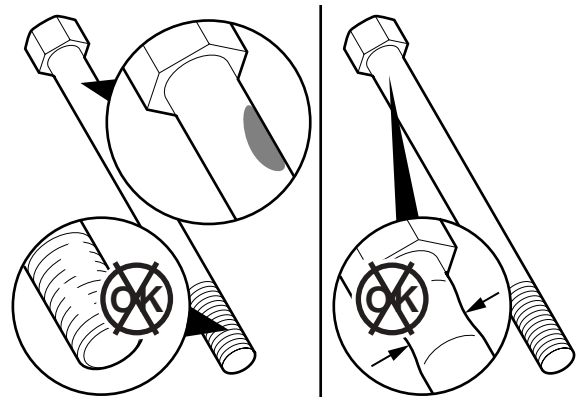

M201248

2. Check the dimensions of visible pitting on the cylinder head bolt, see "Technical data".

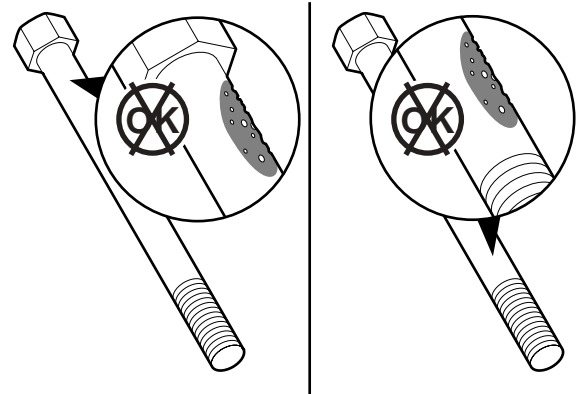

M201249

3. Check the cylinder head bolt for visible corrosion or pitting immediately under the bolt head and directly above the start of the screw thread, see "Technical data".

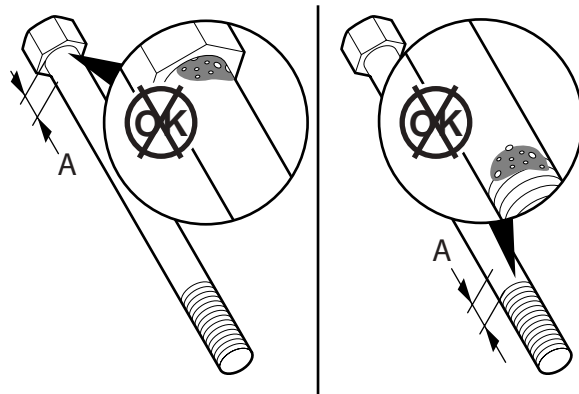

M201250

- 4. Check the free length of the cylinder head bolt. Use the special tool (DAF no. 1329477) for this purpose. Place the bolt head against the abutting surface.

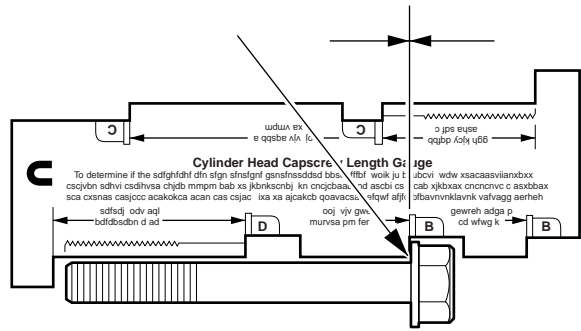

M201251

- 5. The end of the bolt must not touch the gauge.

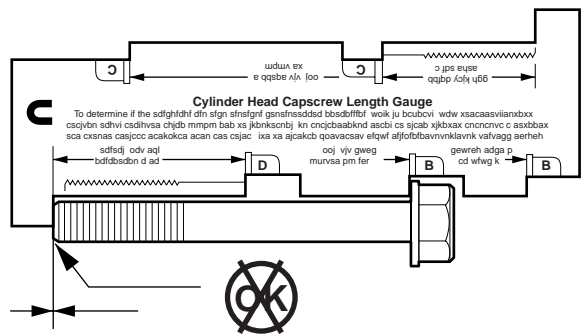

M201252

3.5 INSPECTING THE FLYWHEEL

If cracks are visible on the flywheel, on the contact surface of the clutch plate, it must be replaced.

Checking flywheel run-out

1. Clean the flywheel.
2. Place a metal strip on the edge of the flywheel housing to fit a dial gauge.
3. Place the dial gauge on the metal strip.
4. Place the stylus of the dial gauge as close as possible to the outer edge of the flywheel.
5. Set the dial gauge to "0".

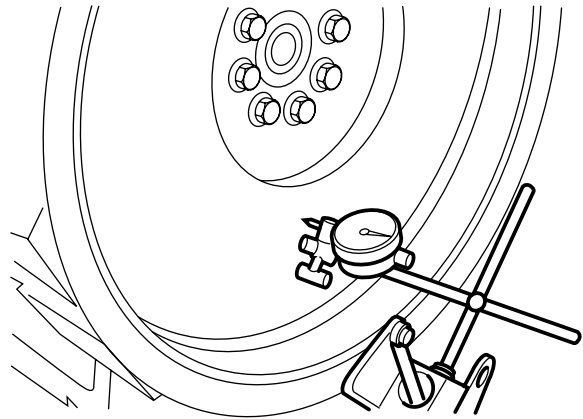

M200230

6. Use an open-end spanner on the fan shaft to crank the engine through 360°, and measure the maximum dial gauge reading. Compare the reading with the specified value, see 'Technical data'.

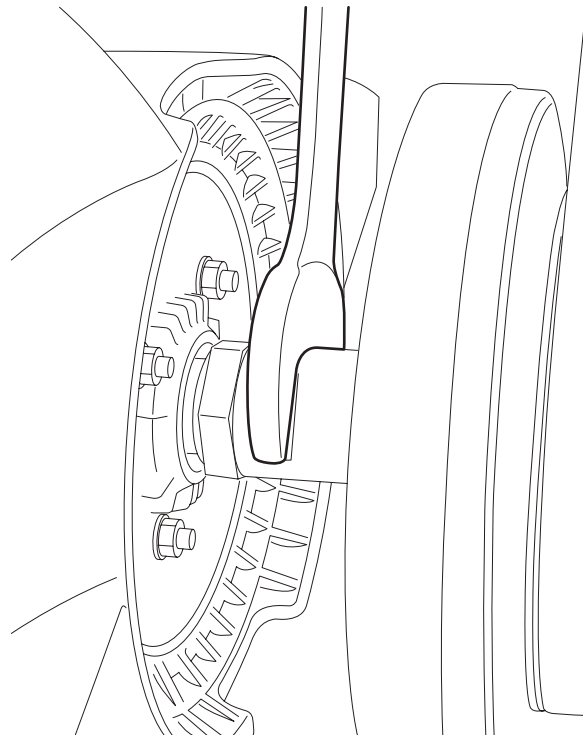

M201318

3.6 INSPECTION, ENGINE OIL SUMP PRESSURE

Be careful when working on an engine at operating temperature.

The oil sump pressure is measured to quickly check the cylinder seals. The readings obtained are an indication of the leakage from all cylinders.

1. Bring the engine up to operating temperature.
2. Turn off the engine and fit the special tool (DAF no. 1240080) (1) to the crankcase breather hose.
3. Fit the special tool with a water pressure gauge (DAF no. 1240081) (2) using a hose and start the engine.
4. Using the water pressure gauge, measure the oil sump pressure at idling speed and compare the measured reading with the technical data. See "Technical data".

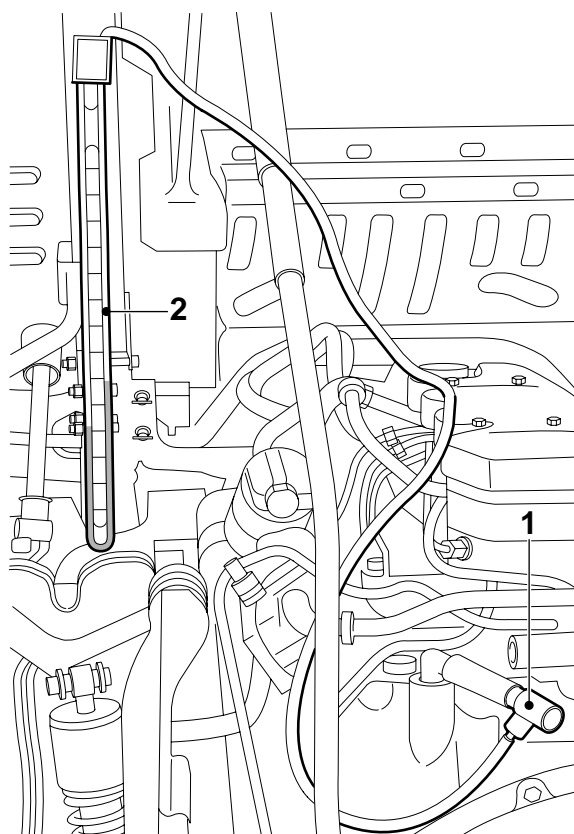

M201316

3.7 INSPECTION, VIBRATION DAMPER

1. Check the reference lines. The reference lines should form a single line.
2. Inspect the rubber part for damage or degradation. If the rubber part shows cracks or if there are bits of rubber missing, the vibration damper must be replaced.

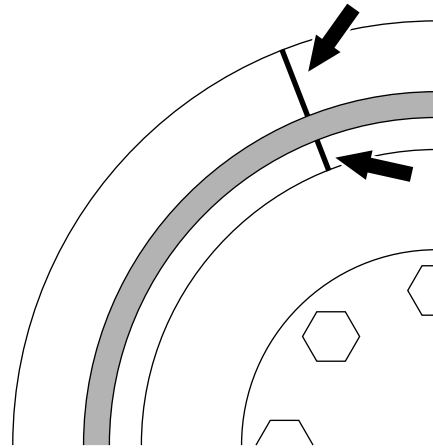

G0 00 199

3.8 INSPECTING THE CYLINDER HEAD

1. Check the sealing plugs and expansion plugs of the cylinder head for leaks. If necessary, pressure-test the cylinder head.
2. Inspect the cylinder head for damage to the sealing surface and any cracks.
3. Check the cylinder head for smoothness using a straight edge and feeler gauge. See "Technical data".

Note:

The cylinder head must be replaced if it does not meet the specified values.

3.9 INSPECTING THE CYLINDER BLOCK

1. Inspect the cylinder block for damage to the sealing surface and any cracks.
2. Check the cylinder block for smoothness using a straight edge and feeler gauge. See "Technical data".

4. REMOVING AND INSTALLING

4.1 REMOVAL AND INSTALLATION, ENGINE



Suspend the engine securely from the hoist, using approved lifting gear.

Various fluids will be released when fluid pipes are removed.

Collect these fluids. Personal safety and the risk of fire should always be considered.

Note:

Because of the large number of vehicle specifications, it is not feasible to exactly specify the engine removal and installation procedures for every vehicle.

This description only includes the most important points requiring attention.

- Disconnect the earth lead from the battery terminal.
- Avoid opening fluid systems as much as possible. If possible, remove and set aside the engine components.
- When removing the engine, ensure that no parts or dirt fall into the engine, radiator or other components. All openings that are freed should therefore be plugged.
- Wiring harnesses are vulnerable. If damaged, they may cause failures. Make sure these wiring harnesses are not live and are clear of moving parts.
- Fit all attachment bolts and tighten them to the correct torque.
- The engine should not be allowed to rest on the oil sump. Because the oil sump is made of sheet material, it will be severely damaged by the engine's weight.
- The engine should not be allowed to rest on the flywheel housing. It can easily be damaged by the engine's weight.

4.2 REMOVAL AND INSTALLATION, ENGINE MOUNTS

Suspend the engine securely from the hoist, using approved lifting gear. Various fluids will be released when fluid pipes are removed. Collect these fluids. Personal safety and the risk of fire should always be considered.

2**Removing the engine mounts**

1. Disconnect the earth lead from the battery terminal.
2. Drain the coolant.
3. Remove the hoses between the engine and the radiator.
4. Remove the attachment bolts from the radiator torque rod bracket on the engine side.
5. Remove the air inlet hoses between the engine and the air cooler. Plug the openings.
6. Detach the air-conditioning pipes, if present, at the top of the radiator.
7. Detach the heater hose bracket at the top of the radiator.
8. Remove the oil supply pipe from the engine.
9. Remove the lower connector from electronic unit ECS-DC3.
10. Remove the attachment bolts of the viscous fan clutch on the drive flange and place the viscous fan clutch with the fan in the wind tunnel.
11. Suspend the engine securely in the hoist.
12. Remove the engine mount attachment bolts at the front and rear of the engine.
13. Hoist the engine very carefully as far as necessary and support it properly.
14. Remove the engine mounts.

Installing the engine mounts

1. Tighten the engine mounting attachment bolts to the specified torque. See "Technical data".
2. Fit the viscous fan clutch with the fan. Tighten the attachment bolts to the specified torque. See "Technical data".
3. Fit the connector of electronic unit ECS-DC3.
4. Fit the oil supply pipe.
5. Fit the heater hose bracket at the top of the radiator.
6. Fit the bracket for the air-conditioning pipes at the top of the radiator.
7. Fit the torque rod bracket between the engine and the radiator.
8. Fit the air inlet hoses between the engine and the air cooler.
9. Fit the coolant hoses between the engine, radiator and the header tank.
10. Fit the torque rod between the radiator and the engine.
11. Fill the cooling system. See "Draining and filling".
12. Connect the battery earth lead.

4.3 REMOVAL AND INSTALLATION, VALVE COVER

When the engine or parts thereof are opened, dirt may enter. This may cause serious damage to the engine. The engine should therefore be cleaned thoroughly before it is opened.

2**Removing the valve cover**

1. Clean the area around the valve cover.
2. Remove the banjo bolt and the attachment of the plastic crankcase breather tube.
3. Remove the valve cover attachment nuts.
4. Remove the valve cover.

Installing the valve cover

1. Clean the sealing surface of the valve sleeve and the valve cover.
2. Check the valve cover gasket. If it is not damaged it may be re-used.
3. Fit the valve cover gasket to the valve cover.
4. Fit the valve cover.
5. Fit the attachment nuts of the valve cover and tighten them to the specified torque. See "Technical data".
6. Fit the plastic crankcase breather tube and the banjo bolt to the valve cover.

4.4 REMOVAL AND INSTALLATION, VALVE SLEEVE



When the engine or parts thereof are opened, dirt may enter. This may cause serious damage to the engine. The engine should therefore be cleaned thoroughly before it is opened.

Removing the valve sleeve

1. Remove the valve cover.
2. Detach the feed-through connectors from the injectors.
3. Remove the injector wiring from the injectors.
4. Remove the attachment bolts from the valve sleeve.
5. Remove the valve sleeve with the gasket.

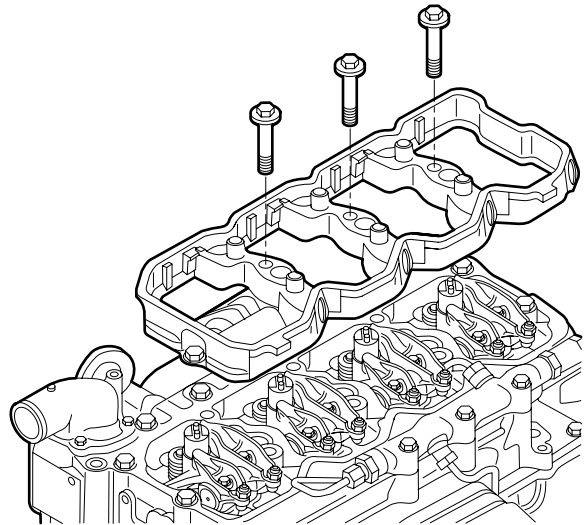

M201082

Installing the valve sleeve

1. Clean the sealing surface of the cylinder head and valve sleeve.
2. Check the valve sleeve gasket. If it is undamaged, it may be re-used. Fit the valve sleeve gasket onto the valve sleeve.
3. Fit the valve sleeve.
4. Tighten the valve sleeve attachment bolts to the specified torque. See "Technical data".



Tightening the injector wiring to a higher torque than specified may cause damage to the injector.

5. Fit the injector wiring on the injectors and tighten it to the specified torque. See "Technical data".
6. Fit the feed-through connectors of the injectors.
7. Fit the valve cover.

4.5 REMOVAL AND INSTALLATION, VALVE GEAR

Removing the valve gear

1. Remove the valve cover.
2. Loosen the lock nuts on the valve stem bolts and unscrew the bolts until they abut.
3. Remove the rocker seat attachment bolts.

Note:

Number the rocker seats so that they can be refitted in their original position.

4. Remove the rocker seats with the rockers.
5. Remove the bridges.

Installing the valve gear

1. Check that the push rods are in the correct position in the valve tappets and apply a drop of engine oil to the push rod cavity.
2. Fit the bridges on the valves.
3. Fit the push rods in their original position.
4. Hand-tighten the rocker seats and rockers in their original position.
5. Tighten the attachment bolts to the specified torque. See "Technical data".
6. Adjust the valve clearance. See "Inspection and adjustment".
7. Fit the valve cover.

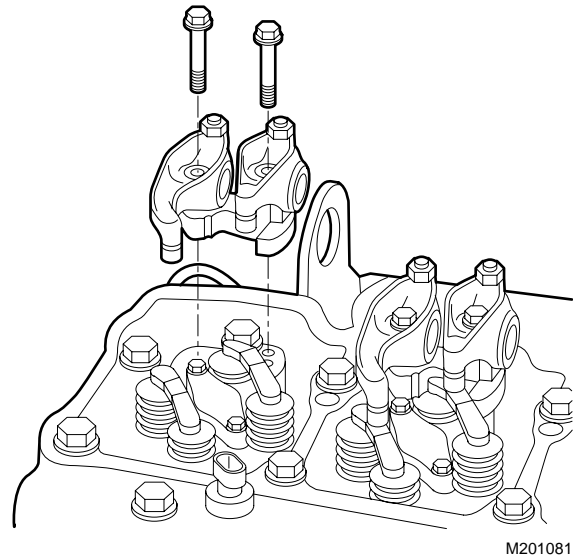

M201081

4.6 REMOVAL AND INSTALLATION, INTAKE MANIFOLD**Removing the intake manifold**

1. Remove the hose from the intake manifold coming from the intercooler.
2. Detach the electric wiring from the glow elements (1) (if fitted) using the connectors.
3. Remove the fuel rail.
4. Remove the inlet air boost pressure sensor/temperature sensor (1) from the intake manifold.
5. Remove the intake manifold (2).
6. Cover the open inlet duct from the cylinder head to prevent the ingress of foreign matter.

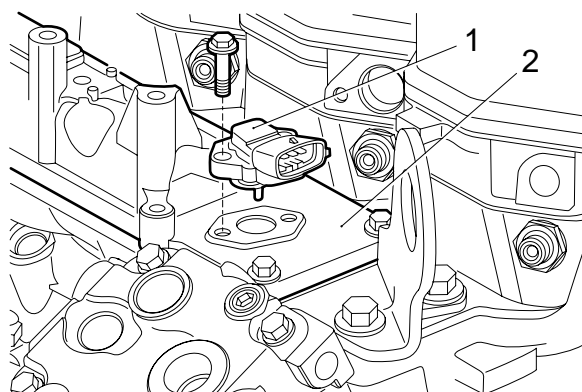
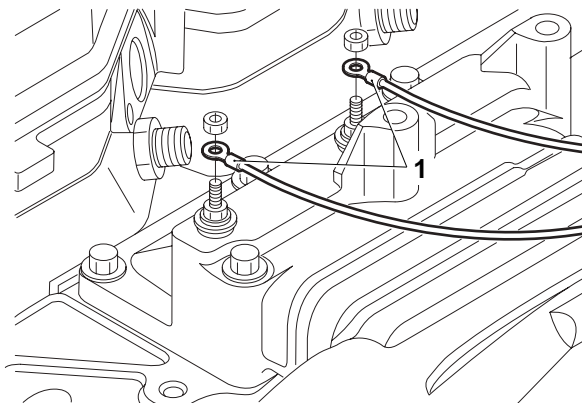

Installing the intake manifold

1. Thoroughly clean the sealing surfaces of the intake manifold and the cylinder head. Do not let any particles fall into the open inlet duct in the cylinder head.
2. Apply a bead (2) of sealant to the sealing surfaces from the cylinder head to the intake manifold (1). See "Technical data".
3. Fit the intake manifold immediately and tighten the attachment bolts to the specified torque. See "Technical data".
4. Fit the inlet air boost pressure sensor/temperature sensor on the intake manifold.
5. Fit the fuel rail.
6. Connect the electric wiring to the glow elements (if fitted) using the connectors (1).
7. Fit the hose to the intake manifold coming from the intercooler.

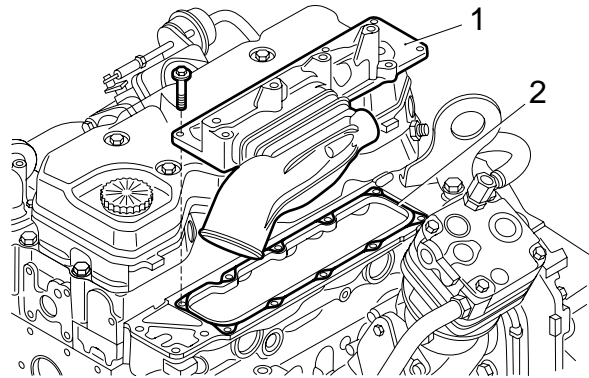

M201396

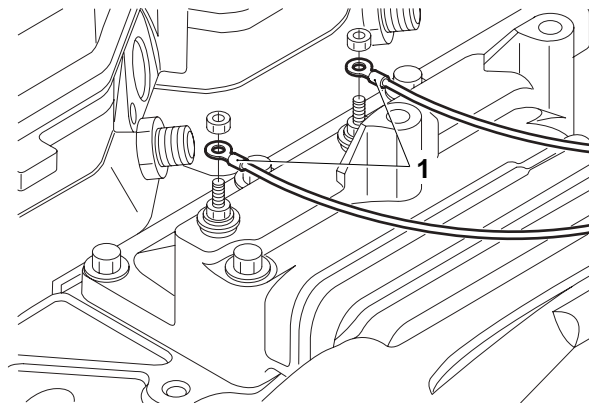

i400521

4.7 REMOVAL AND INSTALLATION, EXHAUST MANIFOLD

Removing the exhaust manifold

1. Remove the heat shields from the exhaust manifold.
2. Remove the turbocharger.
3. Remove the exhaust manifold (1) and gaskets.

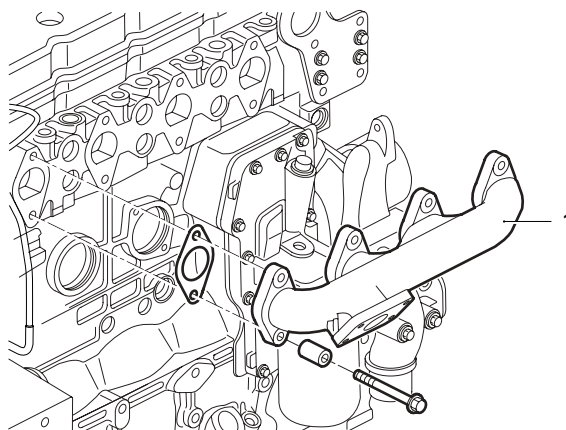

i400524

Installing the exhaust manifold

1. Check the surface of the exhaust manifold for smoothness with a steel ruler (1) and feeler gauge (2). Compare the reading with the values listed in 'Technical data'.
2. Fit new gaskets to the exhaust manifold and install the manifold. Tighten the attachment bolts, from the middle outwards alternately. For the specified tightening torque, see 'Technical data'.
3. Fit the turbocharger.
4. Install the heat shields to the exhaust manifold and tighten the attachment bolts to the specified torque. See 'Technical data'.

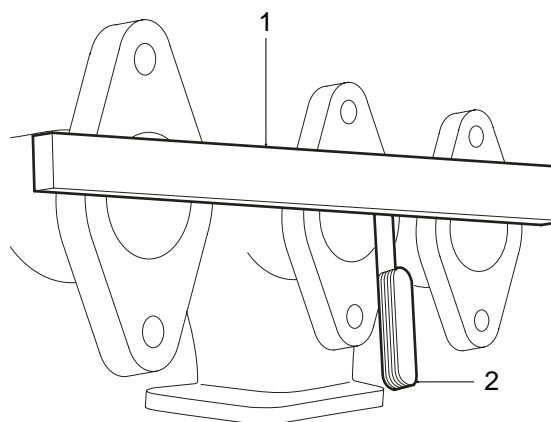

M201397

4.8 REMOVING AND INSTALLING CYLINDER HEAD



When components are removed from any part of the engine, dirt may enter. This may cause serious damage to the engine. The engine should therefore be cleaned thoroughly before it is opened. Plug all openings that are freed.

Removing cylinder head

1. Drain the coolant.
2. Disconnect all electrical wiring around the engine which is required for removing the cylinder head.
3. Disconnect the air inlet pipe from the air cooler on the turbocharger side.
4. Remove the poly-V-belt.
5. Remove the heat shields from the exhaust manifold.
6. If fitted, remove the attachment bolts of the air-conditioning compressor.
7. Remove the attachment bolts from the alternator/air-conditioning compressor bracket and remove the attachment bracket.
8. Remove the attachment bolts from the exhaust manifold and move the manifold and the turbocharger a little away from the cylinder head.
9. Remove the other coolant hoses that are attached to the cylinder head.



When removing components from the fuel system, dirt can enter. This may result in serious damage. The area around the fuel system should therefore be cleaned before opening it. Detached pipes must be plugged immediately.

10. Detach the injector pipes on the injector side.
11. Detach the supply pipe between the high-pressure pump and fuel rail on the fuel rail side.
12. Detach the fuel return pipe from the fuel rail and from the cylinder head.

13. Unscrew the attachment bolts from the fuel rail and remove it.
14. Unscrew the attachment bolts from the intake manifold and remove it.

Note:

To avoid dirt entering the intake opening, it must be taped up.

15. Remove the valve cover.
16. Remove the valve sleeve.
17. Remove the valve gear.
18. Remove the push rods. Mark the push rods so that they can be refitted in their original position.
19. Remove the fuel supply pipes.
20. Remove the injectors.
21. Remove the attachment bolts from the cylinder head in the reverse order to that followed for tightening. See "Technical data".
22. Remove the cylinder head from the cylinder block. Keep the gasket to enable the correct new head gasket to be selected.
23. Remove any gasket remnants from the cylinder head and the cylinder block.
24. Check the cylinder block. See "Checking and adjusting".
25. Check the threaded holes in the cylinder block for damage and cracking.
26. Check the cylinder head. See "Checking and adjusting".

Installing cylinder head

1. Clean the threaded holes in the cylinder head using a screw tap.

Note:

Cylinder head gaskets are available in two thicknesses. The thickness of the cylinder head gasket can be identified by the position of the holes in the projecting cylinder head gasket lip under the exhaust manifold on cylinder 2. See "Technical data" for the cylinder head gasket thicknesses.

2. Position the new cylinder head gasket. If the type of cylinder head gasket is known, use a gasket of the same type as the one removed.

Note:

If the type of cylinder head gasket removed is not known or if the main components of the driving gear have been changed, the type of gasket required must be determined afresh.

To do this, measure the average piston projection. See "Checking and adjusting". Select the correct type of cylinder head gasket using the information in "Technical data" and fit it.

3. Check that all lubricating and coolant ducts are free.
4. Position the cylinder head carefully on the cylinder block and ensure that the cylinder head fits well over the dowel pins.
5. Check the cylinder head bolts. See "Checking and adjusting". Use new cylinder head bolts if one bolt does not meet one or more conditions.
6. Apply engine oil to the thread and to the underside of the bolt head.
7. Position the cylinder head bolts and hand-tighten them.

Note:

The short cylinder head bolts must be fitted in the outer rows.

8. Tighten the cylinder head bolts to the specified torque and in the sequence shown. See "Technical data".
9. Fit the exhaust manifold with new gaskets and tighten the attachment bolts to the specified torque. See "Technical data".
10. Fit the injectors.

Note:

Ensure that the injector is fitted correctly, bearing in mind the supply opening.

11. Fit the fuel supply pipes.

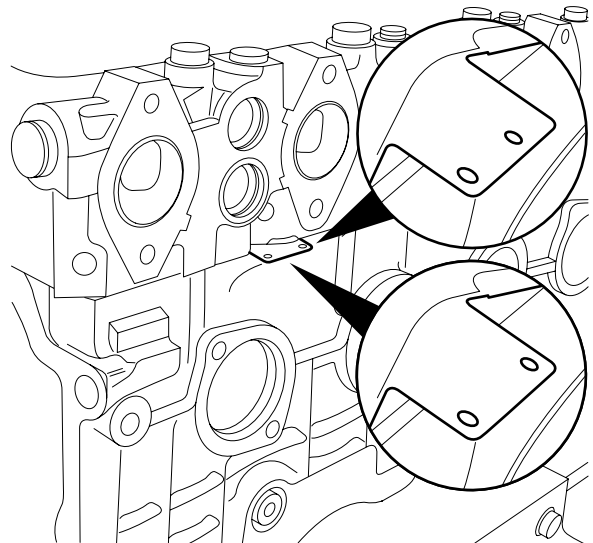

M201230

12. Fit the push rods in their original position and apply a drop of engine oil to the head of the push rod.
13. Fit the valve gear.
14. Fit the valve sleeve.
15. Tighten the injector wiring to the specified torque. See "Technical data".
16. Fit the valve cover.
17. Remove any gasket remnants from the intake manifold and the cylinder head.

Note:

Ensure that the air inlet is free of gasket remnants.

18. Apply sealant to the intake manifold and fit it. See "Technical data".
19. Fit the fuel rail.
20. Fit the injector pipes.
21. Fit the supply pipe between the high-pressure pump and fuel rail.
22. Fit the fuel return pipe on the fuel rail and cylinder head.
23. Connect the various coolant hoses.
24. Fit the bracket of the alternator/air-conditioning compressor.
25. If present, fit the air-conditioning compressor.
26. Fit the poly-V-belt.
27. Fit the heat shields.
28. Fit the air inlet pipe of the air cooler on the turbocharger side.
29. Connect the electrical wiring.

4.9 REMOVAL AND INSTALLATION, AIR COMPRESSOR

Removing the air compressor

1. Partially drain the coolant.
2. Remove the steering pump.
3. Remove the coolant pipes.
4. Remove the air pipes.
5. Remove the attachment bolts from the air compressor and remove it.
6. Remove the O-ring from the compressor housing.

Installing the air compressor

1. Fit the compressor with a new O-ring and tighten the attachment bolts to the specified torque. See "Technical data".
2. Fit the air pipes.
3. Fit the coolant pipes.
4. Fit the steering pump.
5. Fill the cooling system.

4.10 REMOVING AND INSTALLING STEERING PUMP

Note:

When replacing a worn steering pump, you are advised to fully drain the steering oil and replace the steering oil reservoir and integrated filter. In extreme situations, the steering pump may have been worn to such an extent that metal pump parts have entered the steering box. Check the steering box for internal wear using the test case.

Removing steering pump

1. Clean the line connections.
2. Place a receptacle underneath the steering pump.
3. Remove the lines from the steering pump and plug the line and pump openings. The filter is fitted in the return line, which means that should any dirt enter it will immediately also enter the steering gear.
4. Remove the attachment bolts and remove the steering pump (3) and the driver (1) from the compressor.
5. Remove the reservoir (4) from the pump (3).

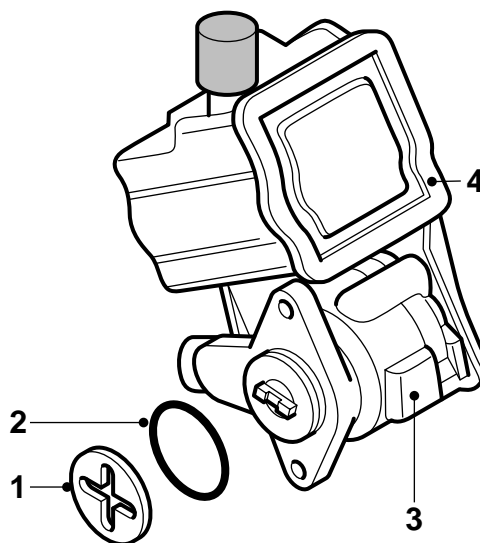

S7 00 575

Installing steering pump

1. If necessary, fit the bracket (2) on top of the new pump. Do not remove the cover from the pump to do this. Tighten the attachment bolts (1) evenly to the specified torque. See "Technical data".

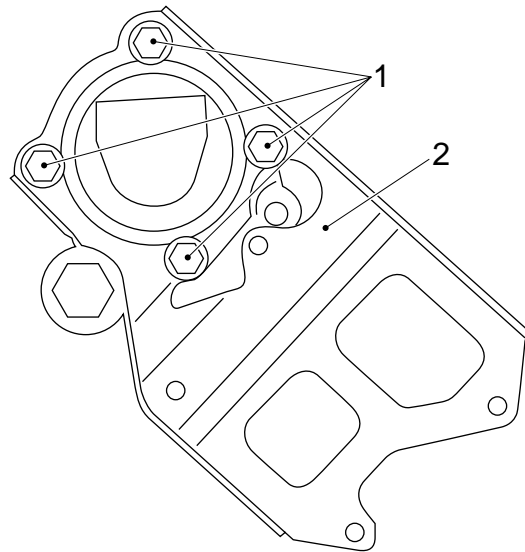

S7 00 609

2. Check the driver (1) for wear.
3. If necessary, connect the line couplings to the steering pump to be fitted. Tighten the couplings to the specified torques; see "Technical data".



If the specified tightening torques are exceeded, the aluminium pump housing may be damaged.

4. Fit a new O-ring (2) on the steering pump and grease it lightly.
5. Crank the engine until the compressor driver half is horizontal.
6. Grease the driver (1) lightly and fit it to the compressor driver half.
7. Fit the reservoir (4) on the pump.
8. Fit the pump (3). Tighten the attachment bolts evenly to the specified tightening torque; see "Technical data".
9. Fit the lines.
10. Fill and bleed the steering gear hydraulic system.
11. Take a test drive and check the pump and line connections for leaks.

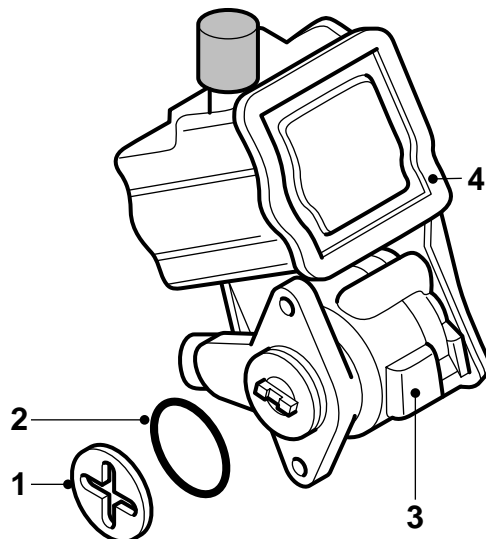

S7 00 575

4.11 REMOVAL AND INSTALLATION, STARTER MOTOR**Removing the starter motor**

1. Remove both battery leads from the battery terminals.
2. Remove the electrical connections from the starter motor.
3. Remove the attachment nuts from the starter motor and remove the starter motor.
4. Check the starter pinion for damage.

Installing the starter motor

1. Clean the contact surfaces of the starter motor and the flywheel housing.
2. Install the starter motor in the flywheel housing and tighten the attachment nuts to the specified torque. See "Technical data".
3. Fit the electrical connections of the starter motor.
4. Reconnect both leads to the battery terminals.

4.12 REMOVAL AND INSTALLATION, POLY-V-BELT

Removing the poly-V-belt

1. Remove the battery terminal clamp from the negative terminal of the starter battery and break the contact.
2. Put a ratchet with a $\frac{3}{8}$ " socket (A) in the arm (B) of the belt tensioner and slacken the belt so that it can be removed from the belt pulleys. Carefully let the belt tensioner expand to the stop.
3. Remove the poly-V-belt (C), lifting it over the fan.

Installing the poly-V-belt

1. Inspect the pulleys for damage, rust and grease deposits. Clean or replace the belt pulleys if necessary.
2. Fit the poly-V-belt over the fan.
3. Place a ratchet with a $\frac{3}{8}$ " socket in the arm of the belt tensioner and push the belt against the spring pressure so that it can be placed on all belt pulleys. Carefully let the belt tensioner spring back until the belt is tensioned.

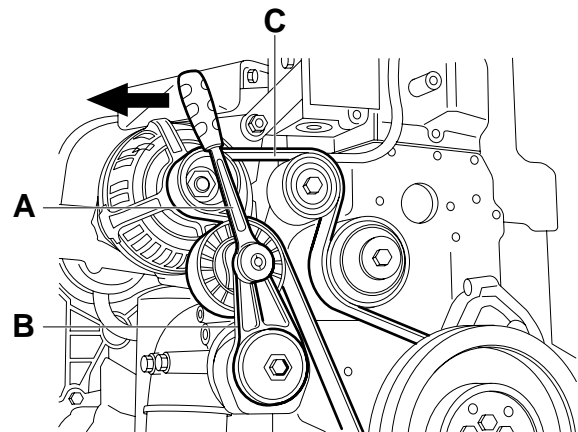

M201430

4.13 REMOVAL AND INSTALLATION, ALTERNATOR**Removing the alternator**

1. Remove both battery leads from the battery terminals.
2. Remove the alternator electrical connections.
3. Remove the poly-V-belt.
4. Remove the attachment bolts from the alternator and remove it.

Installing the alternator

1. Fit the alternator and tighten the attachment bolts to the specified torque. See "Technical data".
2. Fit the poly-V-belt.
3. Fit the alternator electrical connections.
4. Reconnect both leads to the battery terminals.

4.14 REMOVAL AND INSTALLATION, FLYWHEEL

Removing the flywheel

1. Remove the gearbox.
2. Remove the clutch release assembly and the clutch plate.
3. Remove the attachment bolts from the flywheel.
4. To guide the flywheel during removal, fit two threaded ends - each approx. 90 mm - to the now-empty bolt holes.
5. Place two bolts in the circumference of the flywheel and carefully pull the flywheel free.

Installing the flywheel

1. Clean the flywheel housing.
2. Clean the crankshaft flange and attachment bolts.
3. Clean the rear of the flywheel and inspect it. See "Inspection and adjustment".
4. Fit the flywheel.
5. Apply a drop of engine oil to the attachment bolts and install them. Tighten the attachment bolts in a crosswise sequence to the specified torque. See "Technical data".
6. Fit the clutch plate and the clutch release assembly.
7. Fit the gearbox.

4.15 REMOVAL AND INSTALLATION, STARTER RING GEAR**Removing the starter ring gear**

1. Remove the flywheel.
2. Remove the starter ring gear by tapping it off the flywheel, using a blunt chisel. If this is not possible, cut the starter ring gear between two teeth, using a sharp chisel.

Installing the starter ring gear

1. Clean the flywheel and the starter ring gear. Ensure that the contact areas are free of grease.
2. Heat the new starter ring gear evenly in an oven. See "Technical data".
3. Tap the starter ring gear onto the flywheel so that the bevelled sides of the teeth point towards the starter motor. Ensure that the starter ring gear is properly fitted to the flywheel.
4. Fit the flywheel.

4.16 REMOVAL AND INSTALLATION, FLYWHEEL HOUSING SEAL

Removing the flywheel housing seal

1. Remove the gearbox.
2. Remove the clutch release assembly and the clutch plate.
3. Remove the flywheel.
4. Fit the threaded spindle (2) of the special tool (DAF no. 1329475) on the crankshaft flange.
5. Screw the push/pull piece (1) onto the spindle up to the flywheel housing.

Note:

Mark the drill at a length of 22 mm using a piece of tape.

6. Drill a hole through the base plate to the tape marking and fit a screw in the seal to keep the base plate in its place.
7. Drill the other five holes and fit screws.
8. Turn the threaded spindle (2) clockwise until the seal has been removed.

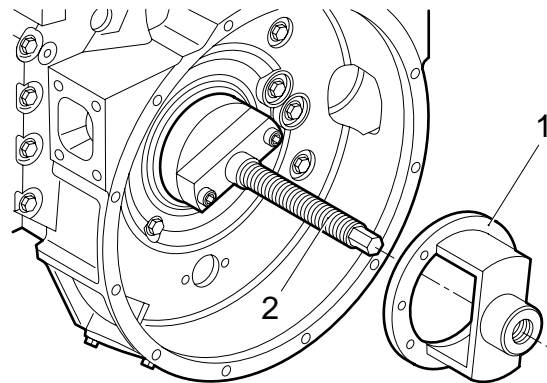

M201068

Installing the flywheel housing seal

1. Clean and inspect the seal chamber. Even minimal damage may cause a leak.
2. Fit the threaded spindle (2) of the special tool (DAF no. 1329475) on the crankshaft flange.
3. Put a new seal over the crankshaft.
4. Screw the push/pull piece (1) onto the threaded spindle (2) up to the seal.
5. Turn the threaded spindle (2) anti-clockwise until the push/pull piece (1) is level with the flywheel housing. The seal has been properly fitted once it is level with the flywheel housing.
6. Remove the special tool.
7. Fit the flywheel.
8. Fit the clutch plate and the clutch release assembly.
9. Fit the gearbox.

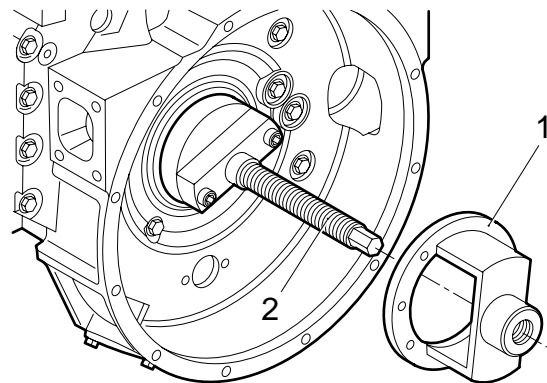

M201068

4.17 REMOVAL AND INSTALLATION, FLYWHEEL HOUSING**Removing the flywheel housing**

1. Remove the starter motor.
2. Remove the flywheel.
3. Remove the flywheel housing seal.
4. Suspend the engine securely in the hoist.
5. Remove the engine brackets.
6. Detach the crankcase breather on the flywheel housing so that the attachment bolt can be accessed.
7. Remove the flywheel housing attachment bolts.
8. Remove the flywheel housing.

Installing the flywheel housing

1. Remove any gasket remnants from the contact areas.
2. Check the sealing surfaces for damage.
3. Check the flywheel housing for cracks.
4. Apply a sealant to the sealing face of the cylinder block. See "Technical data". Apply the sealant with a roller or brush evenly over the entire sealing face.
5. Install the flywheel housing and tighten the attachment bolts in the correct sequence to the specified torque. See "Technical data".
6. Fit the engine brackets.
7. Fit the flywheel housing seal.
8. Fit the flywheel.
9. Fit the starter motor.

4.18 REMOVAL AND INSTALLATION, VIBRATION DAMPER

Removing the vibration damper

1. Remove the attachment bolts of the fan and place the fan in the wind tunnel.
2. Remove the poly-V-belt.
3. Remove the attachment bolts from the vibration damper and remove it.

Installing the vibration damper

1. Check the vibration damper. See "Inspection and adjustment".
2. Fit the vibration damper and tighten the attachment bolts to the specified torque. See "Technical data".
3. Fit the poly-V-belt.
4. Fit the fan.

4.19 REMOVAL AND INSTALLATION, CRANKSHAFT SENSOR RING**Removing the crankshaft sensor ring**

1. Remove the attachment bolts from the viscous fan clutch and place the fan in the wind tunnel.
2. Remove the poly-V-belt.
3. Remove the attachment bolts from the vibration damper.
4. Remove the vibration damper and the crankshaft sensor ring.

Installing the crankshaft sensor ring

1. Fit the crankshaft sensor ring with vibration damper and tighten the attachment bolts to the specified torque. See "Technical data".

Note:

There is only one way of fitting the crankshaft sensor ring. For this purpose, a pin has been fitted which fits into a bore in the crankshaft sensor ring.

2. Fit the poly-V-belt.
3. Fit the fan and tighten the attachment bolts to the specified torque. See "Technical data".

4.20 REMOVING AND INSTALLING FRONT ENGINE PANEL

Removing front engine panel

1. Remove the poly-V-belt.
2. Remove the attachment bolts from the vibration damper and remove the damper along with the crankshaft pulley.
3. Remove the front crankshaft seal.
4. Remove the attachment bolts from the front engine panel and remove it.

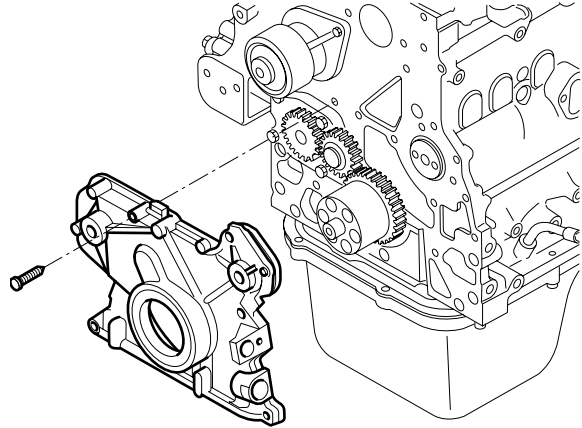

M201157

Installing front engine panel

1. Remove any gasket remnants from the contact areas.
2. Check the sealing surfaces for damage.
3. Check the engine panel for cracks.
4. Apply a sealant to the sealing surface of the cylinder block. See "Technical data". Apply the sealant with a roller or brush evenly over the entire sealing surface.
5. Fit the engine panel and tighten the attachment bolts to the specified torque. See "Technical data".
6. Fit a new front crankshaft seal.
7. Fit the crankshaft pulley and the vibration damper. Tighten the attachment bolts to the specified torque. See "Technical data".
8. Fit the poly-V-belt.

4.21 REMOVAL AND INSTALLATION, CAMSHAFT GEAR

Removing the camshaft gear

1. Remove the flywheel housing.
2. Use an open-end spanner on the fan shaft to crank the crankshaft until the marks in the crankshaft gear and camshaft gear match. The crankshaft gear has a punched hole in the tooth which has to fall into the tooth depth of the camshaft gear marked with a punched hole.
3. Remove the air compressor.

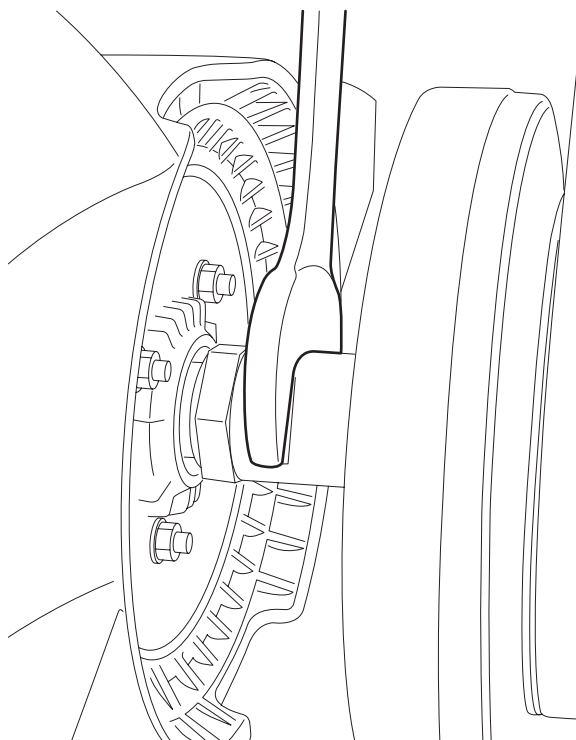

M201318

4. Remove the attachment bolts from the camshaft gear and remove it.

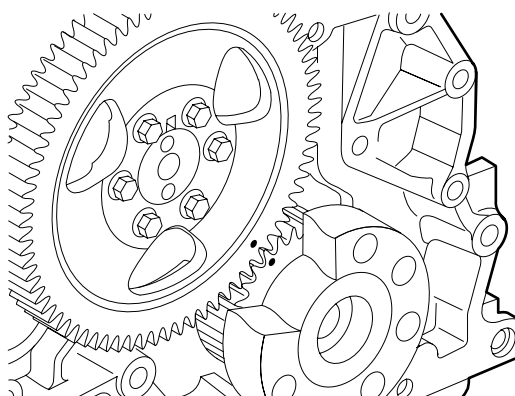

M201146

Installing the camshaft gear

1. Fit the camshaft gear making sure that the timing gear is properly set. See 'Inspection and adjustment'.

Note:

There is only one way of fitting the camshaft gear. For this purpose, a recess has been made which falls over a pin on the camshaft.

2. Tighten the attachment bolts to the specified torque. See 'Technical data'.
3. Fit the air compressor.
4. Fit the flywheel housing.

4.22 REMOVAL AND INSTALLATION, TIMING GEAR CASE

Removing the timing gear case

1. Remove the flywheel housing.
2. Remove the steering pump.
3. Remove the air compressor.
4. Remove the high-pressure pump.
5. Use an open-end spanner on the fan shaft to crank the crankshaft until the marks in the crankshaft gear and camshaft gear match. The crankshaft gear has a punched hole in the tooth which has to fall into the tooth depth of the camshaft gear marked with a punched hole.
6. Remove the camshaft gear.
7. Loosen the sump bolts and remove the sump bolts fitted in the timing gear case.

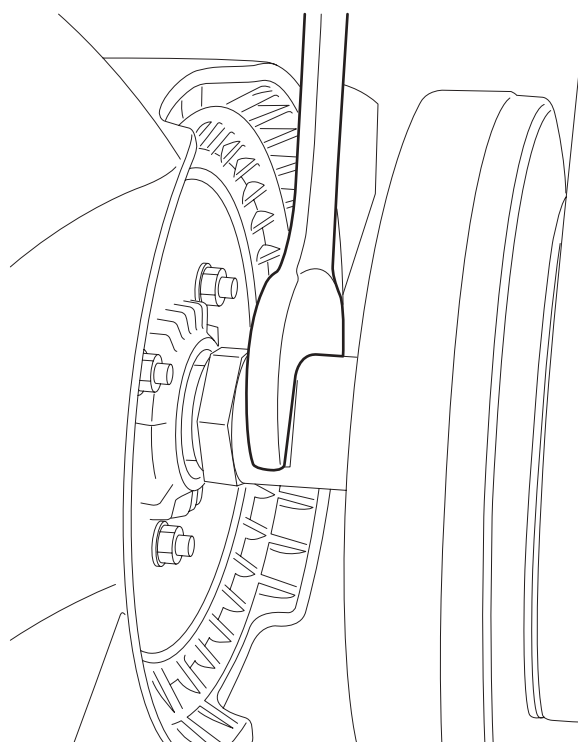

M201318

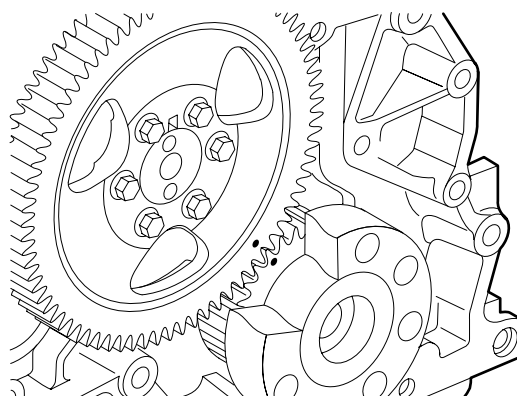

M201146

8. Remove the attachment bolts from the timing gear case and remove it.

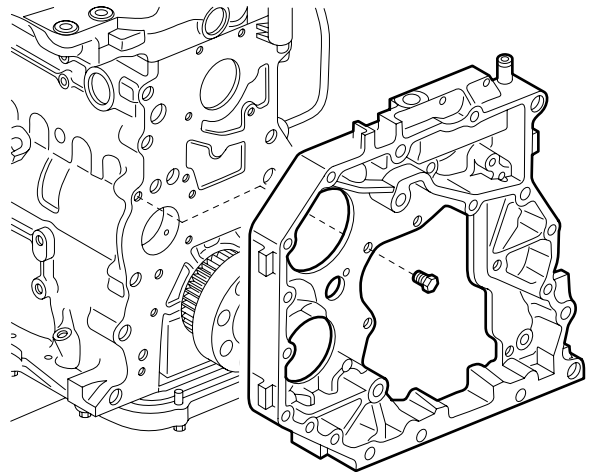

M201147

Installing the timing gear case

1. Apply a sealant to the sealing surface of the cylinder block. See "Technical data". Apply the sealant in accordance with the pattern and at the indicated location. The bead has to be 1.5 to 2.0 mm thick. Fit the timing gear case with liquid sealant and tighten the attachment bolts to the specified torque. See "Technical data".

Note:

If too much sealant is used, or if the sealant is applied in a wrong place, this may cause obstruction of an oil channel or oil sump ventilating duct. This could result in serious damage.

2. Fit the sump bolts and tighten them to the specified torque. See "Technical data".
3. Fit the camshaft gear.
4. Fit the high-pressure pump.
5. Fit the air compressor.
6. Fit the steering pump.
7. Fit the flywheel housing.

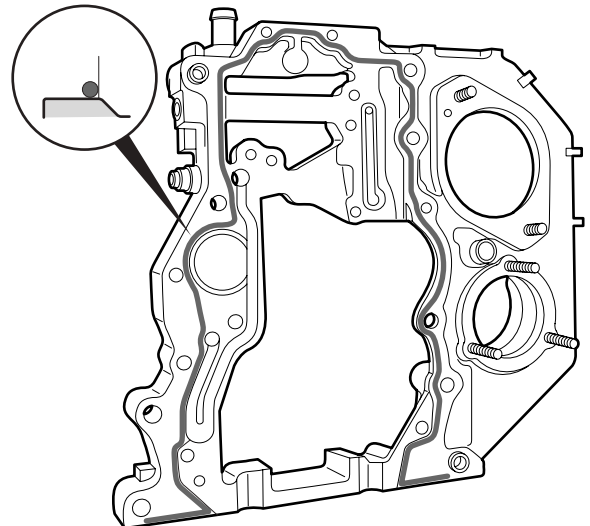

M201242

4.23 REMOVAL AND INSTALLATION, FRONT CRANKSHAFT SEAL

Removing the front crankshaft seal

1. Remove the attachment bolts of the fan and place the fan in the wind tunnel.
2. Remove the poly-V-belt.
3. Remove the attachment bolts from the vibration damper and remove the damper along with the crankshaft pulley.
4. Fit the threaded spindle (2) of the special tool (DAF no. 1453179) on the crankshaft flange.
5. Screw the push/pull piece (1) onto the spindle up to the engine panel.

Note:

Mark the drill at a length of 18 mm using a piece of tape.

6. Drill a hole through the base plate to the tape marking and fit a screw in the seal to keep the base plate in its place.
7. Drill the other five holes and fit screws.
8. Turn the threaded spindle (2) clockwise until the seal has been removed.

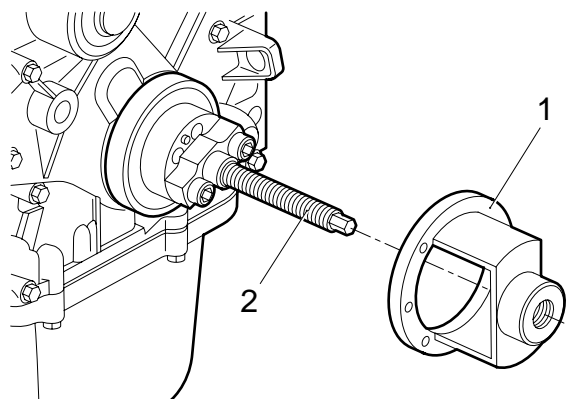

M201069

Installing the front crankshaft seal

1. Clean and inspect the seal chamber. Even minimal damage may cause a leak.
2. Fit the threaded spindle (2) of the special tool (DAF no. 1453179) on the crankshaft flange.
3. Put a new seal over the crankshaft.
4. Screw the push/pull piece (1) onto the threaded spindle (2) up to the seal.
5. Turn the threaded spindle (2) anti-clockwise until the push/pull piece (1) is level with the top panel. The seal has been properly fitted once it is level with the engine panel.
6. Remove the special tool.
7. Inspect the vibration damper.
8. Fit the crankshaft pulley and the vibration damper and tighten the attachment bolts to the specified torque. See "Technical data".
9. Fit the poly-V-belt.
10. Fit the fan.

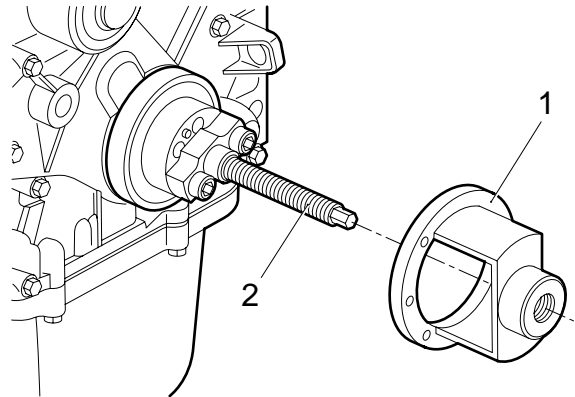

M201069

5. CLEANING

5.1 CLEANING THE ENGINE

Note:

It is advisable to clean the engine and the surrounding area with a high-pressure cleaner before starting maintenance or service operations. A clean environment makes your work easier and enables you to notice any engine defects at an early stage.

Before cleaning the engine, check for any leaks.

If the engine is cleaned with a high-pressure cleaner, this must be done with care. It is also important to observe the following points:

- when cleaning the universal joint on the steering box, the spider seals may be forced open by the high-pressure jet of water, so that the grease behind them is flushed away. As a result, the spider may get stuck, so that the steering mechanism will jam.
- there is a bleed vent on the power steering fluid reservoir of the steering gear. Water may enter the reservoir through this bleed vent, causing damage to the steering gear.
- when cleaning the radiator/intercooler element, be careful not to damage the fins.
- do not direct the high-pressure cleaner jet too long at the air-conditioning system condenser. As a result of the high temperature, the pressure in the system will become excessive, which may cause damage to the system.
- ensure that no water can enter the gearbox via the bleed vents.
- make sure that no water can enter via the clutch reservoir bleed vents.
- the engine compartment can be cleaned with a high-pressure cleaner. Never direct the jet of water towards electrical components.
- do not aim the high-pressure cleaner jet at electrical components and electrical connections such as the electronic unit, sensors, connectors and vehicle lighting through-connections, etc.
- ensure that no water can enter the air inlet system via the air inlet or its flexible seals.

CONTENTS

	Page	Date
1. SAFETY INSTRUCTIONS	1-1	200505
1.1 Safety instructions	1-1	200505
2. GENERAL	2-1	200505
2.1 System description, cooling system	2-1	200505
3. DESCRIPTION OF COMPONENTS	3-1	200505
3.1 Pressure cap	3-1	200505
3.2 Thermostat	3-2	200505
3.3 Viscous fan clutch	3-4	200505
4. CHECKING AND ADJUSTING	4-1	200505
4.1 Pressure-testing cooling system	4-1	200505
4.2 Inspecting the thermostat	4-2	200505
4.3 Inspection, viscous fan clutch	4-3	200505
5. REMOVING AND INSTALLING	5-1	200505
5.1 Removal and installation, coolant pump	5-1	200505
5.2 Removal and installation, thermostat	5-2	200505
5.3 Removal and installation, viscous fan clutch	5-3	200505
5.4 Removal and installation, radiator	5-4	200505
6. DRAINING AND FILLING	6-1	200505
6.1 Draining, filling and bleeding the cooling system	6-1	200505
7. CLEANING	7-1	200505
7.1 Cleaning the exterior of radiator and air cooler	7-1	200505
7.2 Flushing cooling system	7-3	200505

1. SAFETY INSTRUCTIONS

1.1 SAFETY INSTRUCTIONS

Fuel



Diesel fuel is an extremely flammable liquid, and must not be exposed to naked flames or come into contact with hot surfaces. The diesel fuel fumes remaining in an empty fuel tank form an extremely explosive mixture.

When fuel system components are being removed, some fuel will escape. To keep this spillage to a minimum, unscrew the tank cap to release any overpressure.

Any spilled fuel must be collected, bearing in mind the risk of fire.

Exhaust gases

Do not run the engine in an enclosed or unventilated area. Make sure exhaust fumes are properly extracted.



Exhaust gases contain carbon monoxide. Carbon monoxide is a deadly colourless and odourless gas, which, when inhaled, deprives the body of oxygen, leading to asphyxiation. Serious carbon monoxide poisoning may result in brain damage or death.

Moving parts

Remain at a safe distance from rotating and/or moving components.

Various fluids

Various oils and lubricants used on the vehicle may constitute a health hazard. This also applies to engine coolant, windscreen washer fluid, refrigerant in air-conditioning systems, battery acid and clutch fluid. So avoid inhaling and direct contact.

Electrical short-circuit

Always disconnect the battery's earth connection during repair or maintenance operations for which the electric power supply is not required.

2. GENERAL

2.1 SYSTEM DESCRIPTION, COOLING SYSTEM

The cooling system consists of a water pump, a radiator, a header tank, an oil cooler, an air compressor, a thermostat housing with one thermostat and pipes.

The water pump is located below the thermostat in the engine block.

The thermostat housing is part of the cylinder head.

From the delivery side of the water pump, the coolant is directed to the oil cooler via an opening at the back of the water pump. Afterwards the coolant flows to the cylinder block.

The coolant flows through the cylinder block, along the cylinder liners, and up to the cylinder head.

The coolant leaves the cylinder head through the thermostat housing.

Depending on the coolant temperature, the thermostat distributes the coolant flow to the radiator or back to the water pump.

The coolant transported to the radiator enters the radiator at the top and leaves it at the bottom. From the bottom of the radiator, the coolant is returned to the water pump via the return pipe.

The connection pipe to the header tank is also connected to the return pipe from the radiator. When the coolant heats up, it flows to the header tank. When the coolant cools down, it will flow back from the header tank.

The oil cooler is not only intended to cool the lubricating oil, but also to heat it in a "cold" engine.

From the cylinder block, some of the coolant flows through the air compressor.

From the air compressor, the coolant is returned to the engine block via a pipe.

The pipe which takes the coolant to the cab heater is connected to the cylinder head. From the heater, the coolant is returned to the water pump via a pipe.

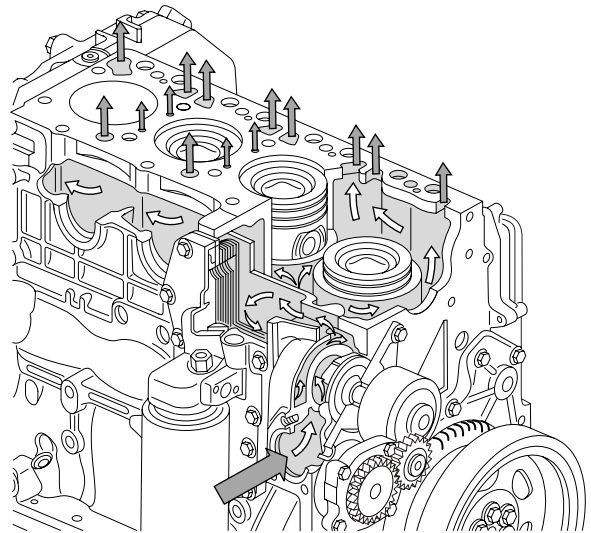

M201133

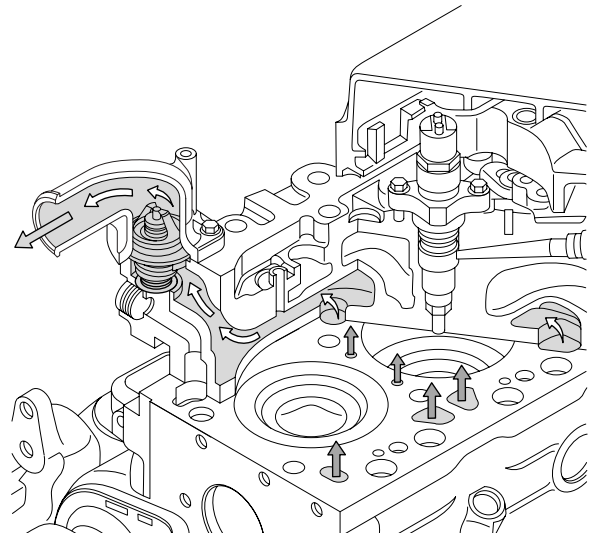

M201134

3. DESCRIPTION OF COMPONENTS

3.1 PRESSURE CAP

The pressure cap is fitted on the header tank by means of a threaded connection.

To fill the cooling system, there is a filler cap at the front of the header tank.

The pressure cap has two valves: a pressure relief valve and a vacuum relief valve. Normally, both valves are closed.

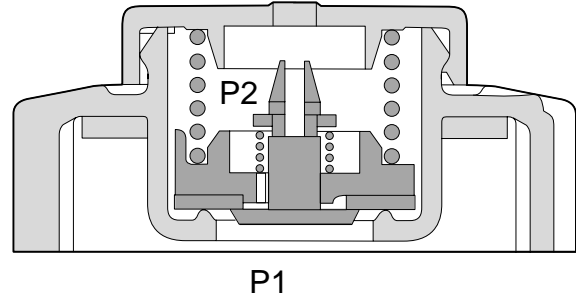

M201151

3

Overpressure

As a result of the rising coolant temperature, the pressure (P1) in the cooling system will increase. If the pressure in the cooling system becomes too high (0.7 bar), the pressure relief valve (1) will open against the pressure of the spring.

Negative pressure

If the coolant temperature drops, the pressure (P1) in the cooling system will decrease. If the pressure (P1) in the cooling system drops to approximately 0.1 bar below the ambient air pressure (P2), the underpressure valve will be opened.

3.2 THERMOSTAT

Operation, thermostat

Coming from the cylinder head, the coolant passes through the thermostat. Depending on the coolant temperature and the corresponding position of the thermostat, there are three possibilities:

Thermostat closed

The coolant has not yet reached the opening temperature of the thermostat (1).

The supply channel (B) to the radiator is completely closed.

The coolant flows directly to the water pump through a bypass (A) and the water pump returns the coolant to the cylinder block.

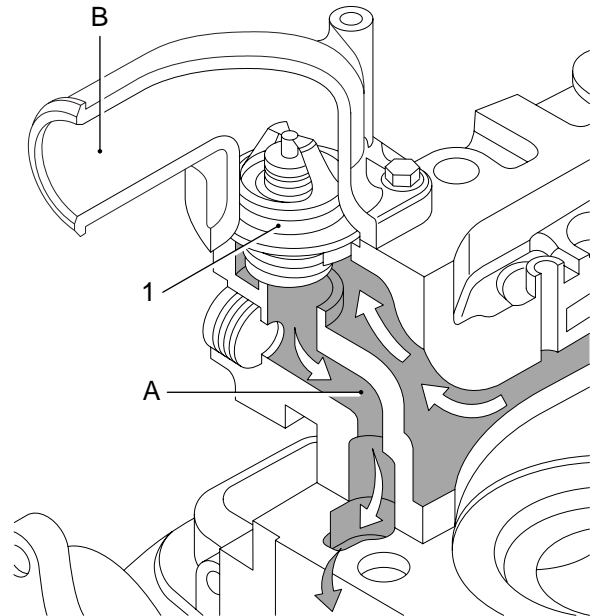

M201126

Thermostat starts opening

The coolant has reached the opening temperature of the thermostat (1).

The supply channel (B) to the radiator is opened and the bypass (A) is partially closed.

Now coolant will flow both through the supply channel (B) to the radiator and directly to the water pump through the bypass channel (A).

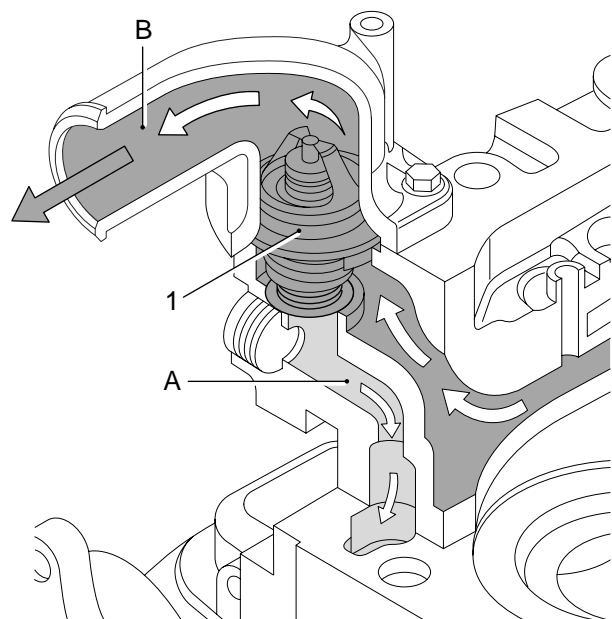

M201127

Thermostat fully opened

The temperature of the coolant has further increased. The supply channel (B) to the radiator is fully opened and the bypass (A) is fully closed. The entire coolant circulation now flows via the supply channel (B) to the radiator where it is cooled before flowing back to the water pump.

In the event of excessive coolant temperatures, removing the thermostat as an emergency solution is **not permitted**.

If the thermostat is removed from the engine, uncooled coolant will flow to the water pump through the bypass (A). As a result, the coolant temperature will continue to rise.

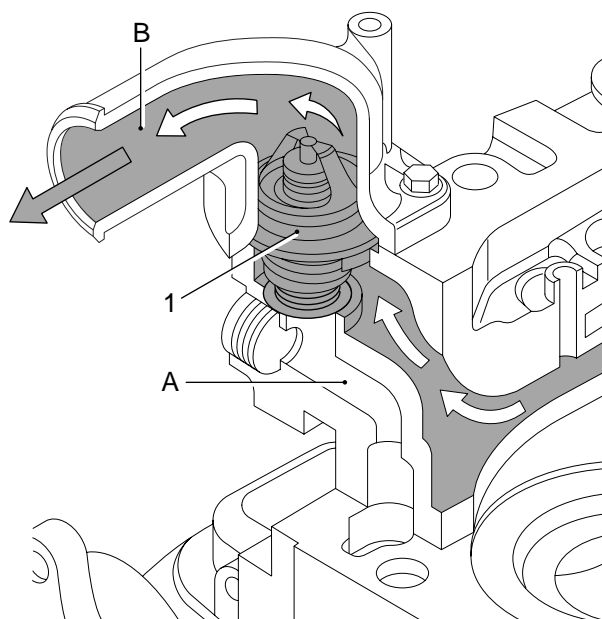

3.3 VISCOUS FAN CLUTCH

The fan is connected to the engine by means of a viscous fan clutch. If, under certain circumstances, the heat is not sufficiently dissipated by the air flow passing through the radiator, the fan will have to draw in extra cooling air through the radiator. In a viscous fan clutch, the drive torque is transmitted by a silicone fluid.

The fan clutch is divided into two chambers. In the working area (1) is the rotor (2), which is connected to the drive flange (7). The supply chamber (3) rotates freely round the drive flange (7) and is connected to the fan. There is silicone fluid in the supply chamber (3). The opening (4) in the supply chamber (3) is closed by a valve (5). The valve (5) is operated by a bimetallic strip (6).

If the opening (4) in the supply chamber (3) is closed by the valve (5), no silicone fluid can enter the working area (1). The silicone fluid still present in the working area (1) will flow back to the supply chamber (3) through the bores (8). As only very little fluid will be left in the working area (1), there will be a great difference in rotating speed (slip) between the drive flange (7) and the supply chamber (3) with the fan.

When the air temperature increases, the bimetallic strip (6) will bend and the valve (5) will partially release the opening (4) in the supply chamber (3). Through this opening, a limited amount of silicone fluid can enter the working area (1) and flow past the rotor (2). This will cause friction, so that the difference in rotating speed (slip) between the drive flange (7) and the supply chamber (3) with the fan will decrease.

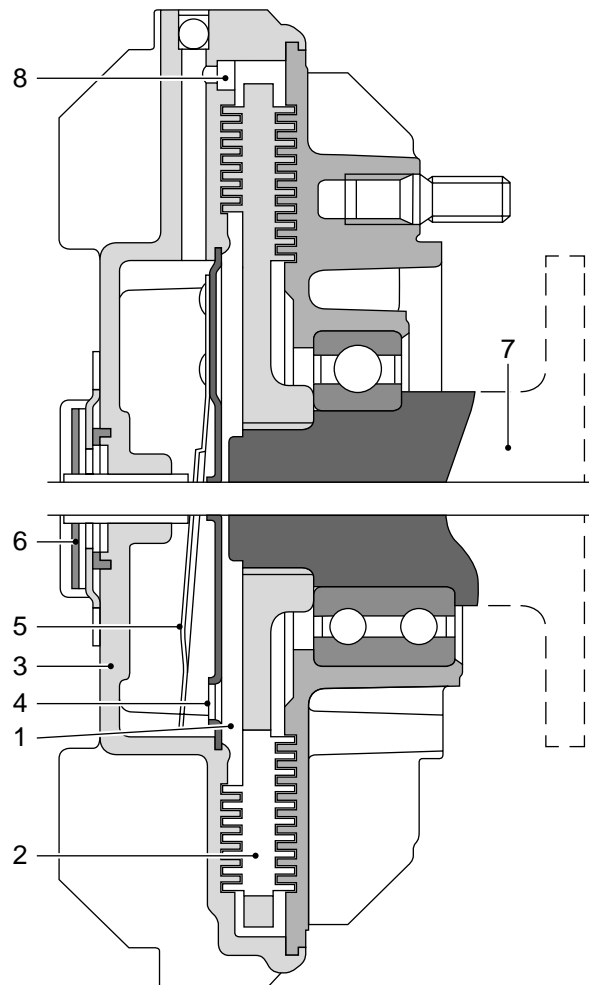

M201039

As the air temperature rises, the bimetallic strip (6) will continue to bend and the opening (4) in the supply chamber (3) will be fully released.

The further the opening (4) in the supply chamber (3) is released, the more silicone fluid will flow into the working area (1) and past the rotor (2). As a result of the increase in friction, the difference in rotating speed (slip) between the drive flange (7) and the supply chamber (3) will further decrease.

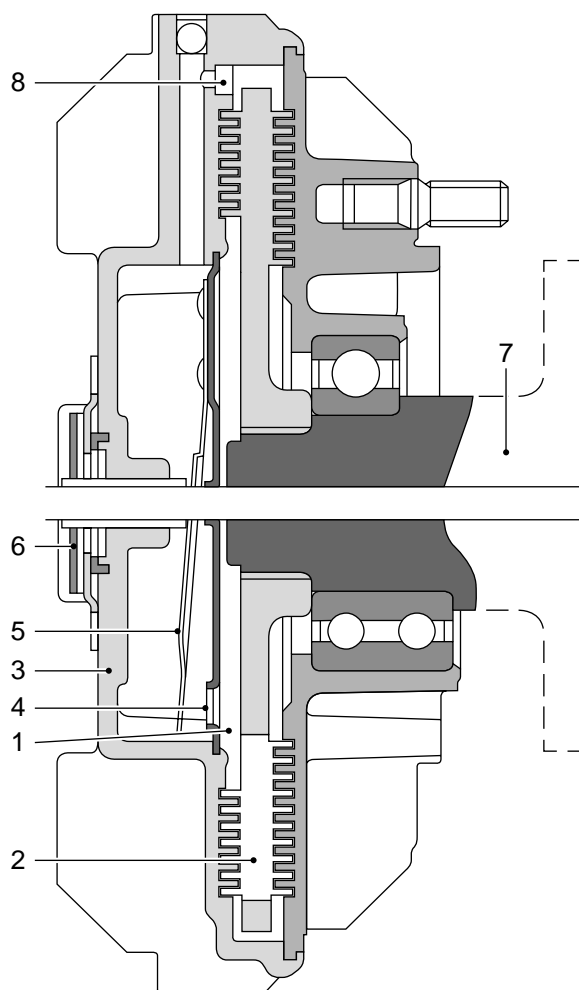

M201039

4. CHECKING AND ADJUSTING

4.1 PRESSURE-TESTING COOLING SYSTEM



When the coolant is hot, there is overpressure in the cooling system. Carefully remove the filler cap to release the overpressure. Coolant is a toxic fluid. Contact with the skin should therefore be avoided. To avoid damaging the cylinder block, do not top up a warm engine with cold coolant.

The cooling system can be checked for leaks with a pressure-test pump. If this is done when the engine is warm, any cracks can be spotted more quickly.

1. Open the grille.
2. Remove the filler cap.
3. Fill the cooling system to the correct level.
4. Raise the engine temperature. This need not be the operating temperature.

Note:

By fitting the pressure-test pump onto the filler opening of the header tank, the pressure cap can also be tested.

5. Fit a pressure-test pump. Pressure-test the system at the specified pressure. See "Technical data".
6. Check the cooling system for leakage.

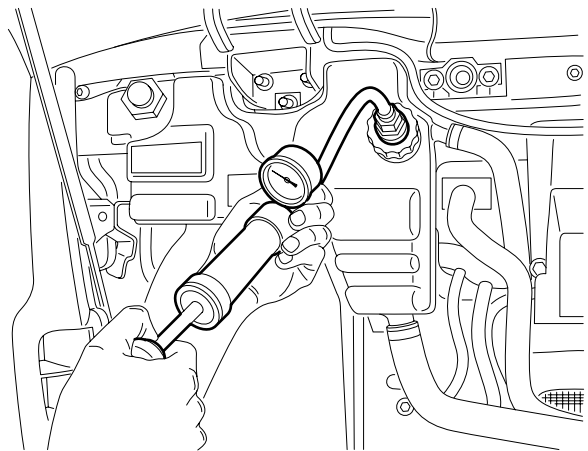

M201149

4.2 INSPECTING THE THERMOSTAT

1. Remove the thermostat. See "Removal and installation".
2. Inspect the sealing surfaces of the thermostat housing for damage.
3. Check the thermostat seat for damage.
4. Check whether the thermostat is fully closed.
5. Place the thermostat in a container filled with clean water.
6. Place a thermometer in the container and heat the water. Check at which temperature the thermostat opens and whether it opens fully. See "Technical data".

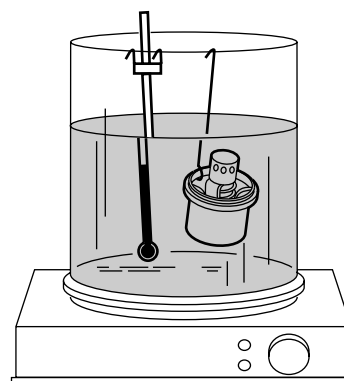

M200513

4.3 INSPECTION, VISCOUS FAN CLUTCH



Do not run the engine in an enclosed or unventilated area. Make sure exhaust fumes are properly extracted. Remain at a safe distance from rotating and/or moving components.

Testing with a cold engine

During this test, the slip in the viscous fan clutch is measured while the clutch is not operating. This test must be carried out when the engine is "cold" (coolant temperature approximately 50°C).

1. Check the coolant level, and top up as necessary.
2. Start the engine and run it at idling speed for at least 5 minutes.
Then use an optical rev counter to measure the fan speed at different engine speeds (from idling to maximum engine speed). During this test procedure, the speed of the fan should be approx. 600 to 1100 rpm.

Testing with a warm engine

This test checks whether the bimetallic strip starts opening the valve at an operating temperature of 85 - 95°C.

1. Check the coolant level, and top up as necessary. Be careful when topping up the coolant of a warm engine.
2. Take a sheet of cardboard with a 100 mm hole, as shown in the drawing opposite, and place it in front of the radiator, with the hole in front of the viscous clutch.
3. Check that the gearbox is in neutral.
4. Bring the cooling system to operating temperature.
5. Allow the fan drive flange to run at a speed of 1000 rpm. Then use an optical rev counter to determine the difference between the rotating speeds of the fan and the drive flange. The speeds will differ as a result of slip in the viscous clutch. When the clutch is fully engaged, the slip must not exceed 10%. If it is more, the viscous fan clutch must be replaced.

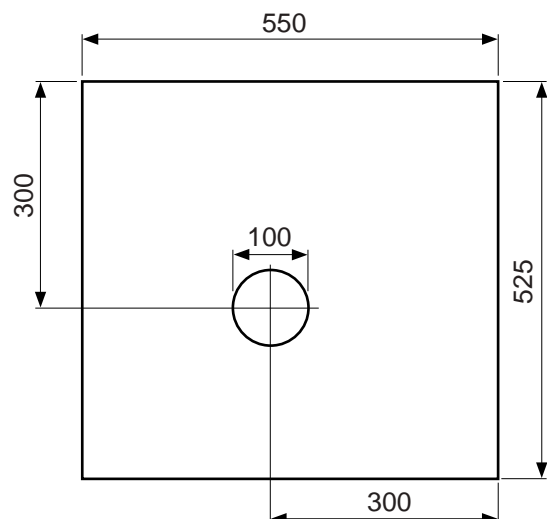

M201167

5. REMOVING AND INSTALLING

5.1 REMOVAL AND INSTALLATION, COOLANT PUMP

Removing the coolant pump

1. Drain the coolant. See "Draining and filling".
2. Remove the poly-V-belt.
3. Remove the attachment bolts from the coolant pump and remove it.

Installing the coolant pump

1. Thoroughly clean the sealing surfaces of the coolant pump and the cylinder block.
2. Fit a new O-ring to the coolant pump.
3. Install the coolant pump and tighten the attachment bolts to the specified torque. See "Technical data".
4. Fit the poly-V-belt.
5. Fill the cooling system. See "Draining and filling".

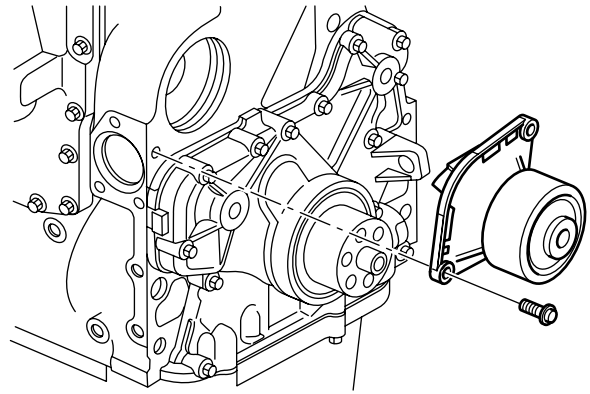

M201137

5.2 REMOVAL AND INSTALLATION, THERMOSTAT**Removing the thermostat**

1. Drain the coolant. See "Draining and filling".
2. Remove the water hose between the thermostat housing and the radiator.
3. Remove the thermostat housing attachment bolts.
4. Remove the thermostat housing.
5. Remove the thermostat.

Installing the thermostat

1. Fit a new sealing ring to the thermostat.
2. Fit the thermostat in the thermostat housing.
3. Fit the thermostat housing onto the cylinder head.
4. Fit the thermostat housing attachment bolts. Tighten the attachment bolts to the specified torque. See 'Technical data'.
5. Fit the water hose between the thermostat housing and the radiator.
6. Fill the cooling system. See "Draining and filling".

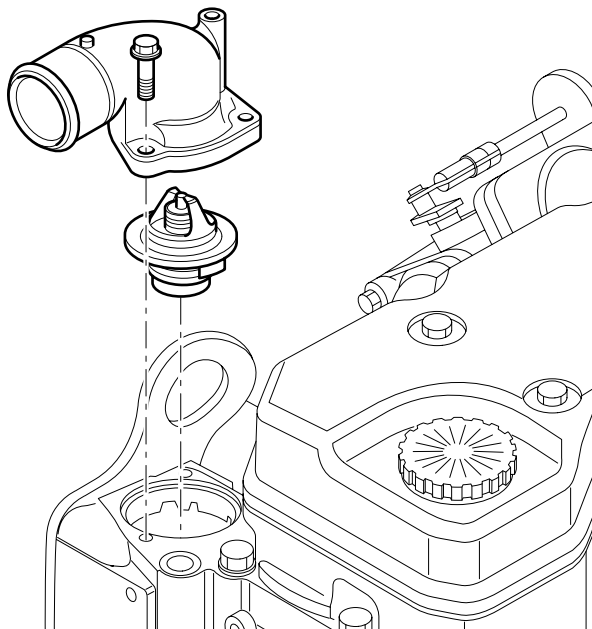

M201156

5.3 REMOVAL AND INSTALLATION, VISCOUS FAN CLUTCH

Removing the viscous fan clutch

1. Drain some of the coolant. See "Draining and filling".
2. Remove the air inlet hose with air inlet pipe between the intercooler and the inlet manifold (1).
3. Disconnect the heater hose (2) and bleed hose (3) on engine side and bend it to the front.
4. Remove the attachment nuts from the fan.
5. Remove the bolts attaching the viscous fan clutch to the drive flange. Remove the viscous fan clutch with the fan from the wind tunnel.

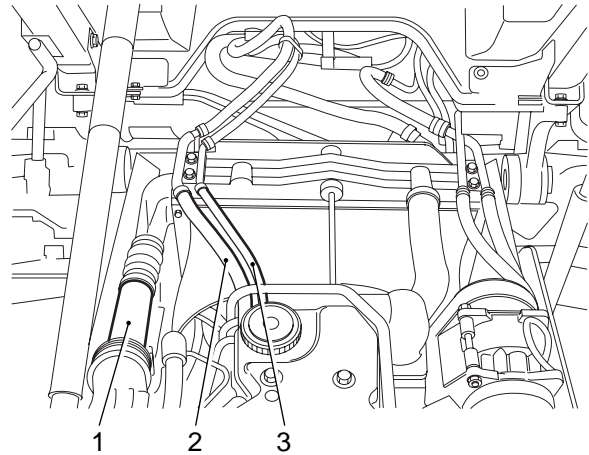

M201161

Note:

The viscous fan clutch must always be stored **vertically**.

Installing the viscous fan clutch

1. Place the new viscous fan clutch in the fan. Position it in the wind tunnel and fit the viscous fan clutch with the fan onto the drive flange.
2. Tighten the attachment nuts of the fan.
3. Fit the heater hose (2) and bleed hose (3).
4. Fit the air inlet hose with air inlet pipe between the intercooler and the inlet manifold (1).
5. Fill the cooling system. See "Draining and filling".
6. Run the engine and check that all connections are sealed properly.

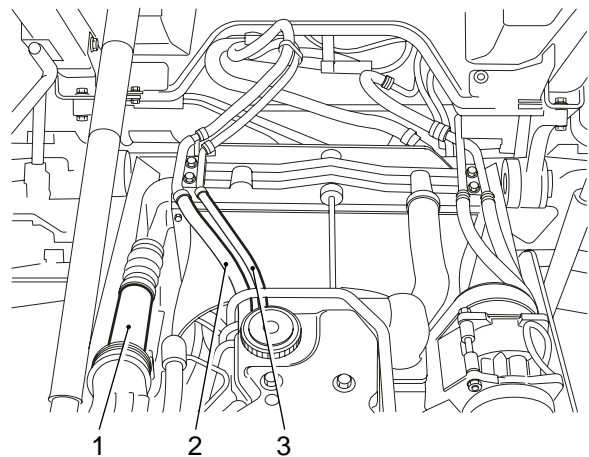

M201161

5.4 REMOVAL AND INSTALLATION, RADIATOR

Note:

The removal and installation procedure for the radiator unit allows for the presence of an air-conditioning unit.

If such a unit is not present, the relevant sections can be skipped.

Removal, radiator

1. Drain the coolant.
2. Remove the fan.
3. Remove the coolant hoses from the radiator.
4. Remove the bracket (1) of the air-conditioning pipes from the radiator.
5. Remove the left-hand air inlet hose (2) and air inlet pipe (3) from the inlet manifold to the intercooler.
6. Remove the right-hand connecting hose from the inlet pipe to the intercooler.
7. Remove the bracket (4) of the heater and bleed hoses from the radiator.
8. Remove the torque rod (5).
9. Remove the retainer clips from the condenser brackets.
10. Remove the bolts of the wind tunnel (6) and remove the wind tunnel.
11. Remove the attachment bolts from the intercooler and remove the cover plate.
12. Remove the attachment bolts from the radiator brackets. Remove the radiator and tilt the condenser slightly to free the air-conditioning pipes.

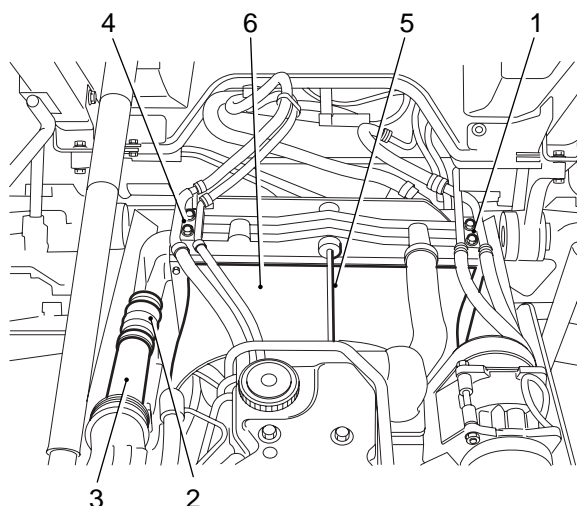

M201162

Installing the radiator

1. Fit the radiator in the chassis. Tighten the attachment nuts to the specified torque. See "Technical data".
2. Fit the intercooler onto the radiator and fit the cover plate.
3. Install the wind tunnel (6).
4. Install the torque rod (5).
5. Suspend the condenser at the bottom in the brackets and fit the retainer clips.
6. Fit the fan.
7. Fit the bracket (4) of the heater and bleed hoses on the radiator.
8. Fit the coolant hoses to the radiator
9. Fit the right-hand air inlet hose from the inlet pipe to the intercooler.
10. Fit the left-hand air inlet hose (2) and air inlet pipe (3) from the inlet manifold to the intercooler.
11. Fit the bracket (1) of the air-conditioning pipes on the radiator
12. Fill the cooling system. See "Draining and filling".
13. Run the engine and check that all connections are sealed properly.

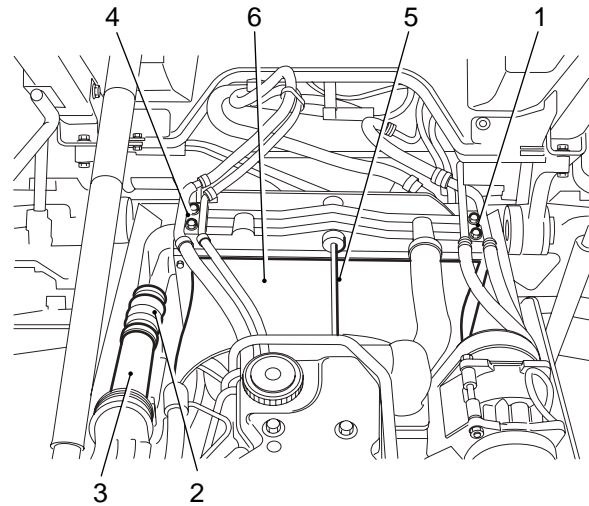

M201162

6. DRAINING AND FILLING

6.1 DRAINING, FILLING AND BLEEDING THE COOLING SYSTEM



In order to avoid damaging the engine block, do not top up a warm engine with cold coolant. Coolant is a toxic fluid and must be handled with care. Protect skin and eyes. Coolant is harmful to the environment; after use, it should be processed as industrial chemical waste. When the coolant is hot, there is overpressure in the cooling system. When removing the filler cap, allow the overpressure to escape by first loosening the filler cap one turn.

Draining the cooling system

1. Turn the heater temperature control knob in the cab to the maximum 'hot' setting.
2. Remove the cooling system filler cap.
3. Collect the coolant. Position suitable containers under the drain points.
4. Drain the cooling system at the radiator via the drain plug.
5. Flush the cooling system.
6. Close the drain plug.

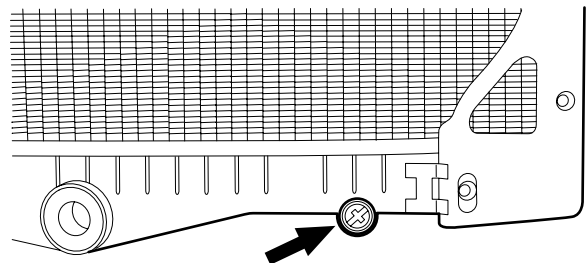

M201084

Filling and bleeding the cooling system

1. Turn the heater temperature control knob in the cab to the maximum 'hot' setting.
2. Fill the cooling system with the specified coolant.
3. Run the engine for several minutes.
4. The cooling system is self-bleeding. Ensure that the bleed pipe from the thermostat housing to the header tank is not kinked or pinched.

Note:

Make sure that air can escape when the cooling system is filled.

5. Check the coolant level, and top up with coolant if necessary.

7. CLEANING

7.1 CLEANING THE EXTERIOR OF RADIATOR AND AIR COOLER



Inhalation of dust may have serious consequences for your health. Take the necessary precautions, such as wearing goggles and a facemask.

Note:

With the aid of a simple tool, the radiator and the air cooler can be blow-cleaned.

The tool (radiator cleaner) cannot be ordered from DAF. It should be manufactured by yourself according to the drawing.

Key to drawing:

- 1 Solder up
- 2 Solder
- 3 Quick-release coupling for air hose
- 4 Steel pipe, \varnothing 10 mm
- 5 6 x \varnothing 1.5 mm between holes, with a centre-to-centre distance between the holes of 7 mm, drilled on one side

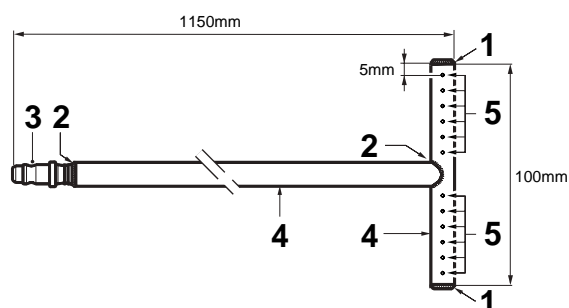

M2108

3

1. If the vehicle has air conditioning, loosen the support of the refrigerant pipes (1) on the radiator and remove the condenser from the air cooler supports. Push the condenser as far as possible forwards.

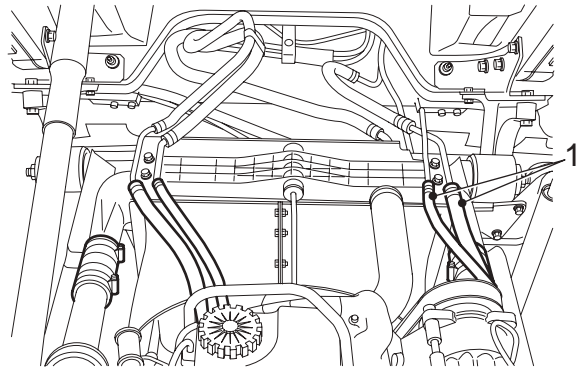

i400824

2. Insert the radiator cleaner (3) between the air cooler (1) and radiator (2) from underneath, with the air holes facing the air cooler (1).
3. Apply air pressure to the radiator cleaner (3) and continue blow-cleaning the air cooler (1) until no more dirt comes out.

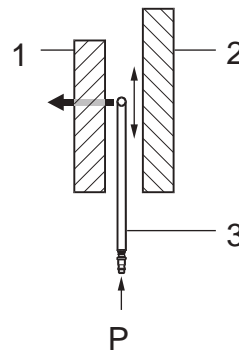

M201351

4. Turn the radiator cleaner (3) over, turning the holes towards the radiator (2), and blow-clean the radiator (2).

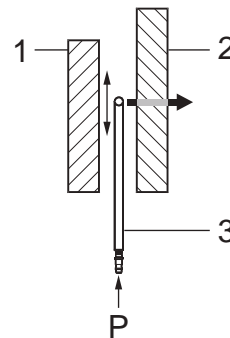

M201352

5. If the vehicle has air conditioning, fit the condenser in the air cooler supports and tighten the support of the refrigerant pipes (1) on the radiator.

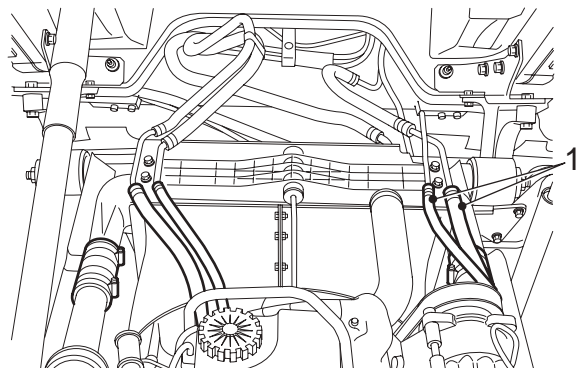

i400824

7.2 FLUSHING COOLING SYSTEM



In order to avoid damaging the engine block, do not top up a warm engine with cold coolant or other fluid.

Coolant is a toxic fluid and must be handled with care. Protect skin and eyes.

Coolant is harmful to the environment; after use, it should be processed as industrial chemical waste.

1. Drain the entire cooling system.
2. Fill the cooling system with tap water and add a cooling system cleaner. See "Technical data".
3. Leave the engine running until the thermostat is fully open.
4. Now leave the engine running for a further 45 minutes.
5. Drain the entire cooling system.
6. Fill the cooling system with tap water.
7. Leave the engine running until the thermostat is fully open.
8. Now leave the engine running for a further five minutes.
9. Drain the entire cooling system.
10. Fill the cooling system with the specified coolant.
11. Check the coolant level.

CONTENTS

	Page	Date
1. SAFETY INSTRUCTIONS	1-1	200505
1.1 Safety instructions	1-1	200505
2. GENERAL	2-1	200505
2.1 System description, lubrication system	2-1	200505
3. CHECKING AND ADJUSTING	3-1	200505
3.1 Checking engine oil consumption	3-1	200505
3.2 Inspection, lubricating oil pressure	3-2	200505
3.3 Pressure-testing the oil cooler	3-3	200505
3.4 Inspecting the lubricating oil pump	3-4	200505
4. REMOVING AND INSTALLING	4-1	200505
4.1 Removal and installation, lubricating oil filter	4-1	200505
4.2 Removal and installation, oil cooler	4-2	200505
4.3 Removal and installation, oil sump	4-3	200505
4.4 Removing and installing lubricating oil pump	4-4	200505
5. DRAINING AND FILLING	5-1	200505
5.1 Draining and replenishing engine oil	5-1	200505

1. SAFETY INSTRUCTIONS

1.1 SAFETY INSTRUCTIONS

Fuel



Diesel fuel is an extremely flammable liquid, and must not be exposed to naked flames or come into contact with hot surfaces. The diesel fuel fumes remaining in an empty fuel tank form an extremely explosive mixture.

When fuel system components are being removed, some fuel will escape. To keep this spillage to a minimum, unscrew the tank cap to release any overpressure.

Any spilled fuel must be collected, bearing in mind the risk of fire.

Exhaust gases

Do not run the engine in an enclosed or unventilated area. Make sure exhaust fumes are properly extracted.



Exhaust gases contain carbon monoxide. Carbon monoxide is a deadly colourless and odourless gas, which, when inhaled, deprives the body of oxygen, leading to asphyxiation. Serious carbon monoxide poisoning may result in brain damage or death.

Moving parts

Remain at a safe distance from rotating and/or moving components.

Various fluids

Various oils and lubricants used on the vehicle may constitute a health hazard. This also applies to engine coolant, windscreen washer fluid, refrigerant in air-conditioning systems, battery acid and clutch fluid. So avoid inhaling and direct contact.

Electrical short-circuit

Always disconnect the battery's earth connection during repair or maintenance operations for which the electric power supply is not required.

2. GENERAL

2.1 SYSTEM DESCRIPTION, LUBRICATION SYSTEM

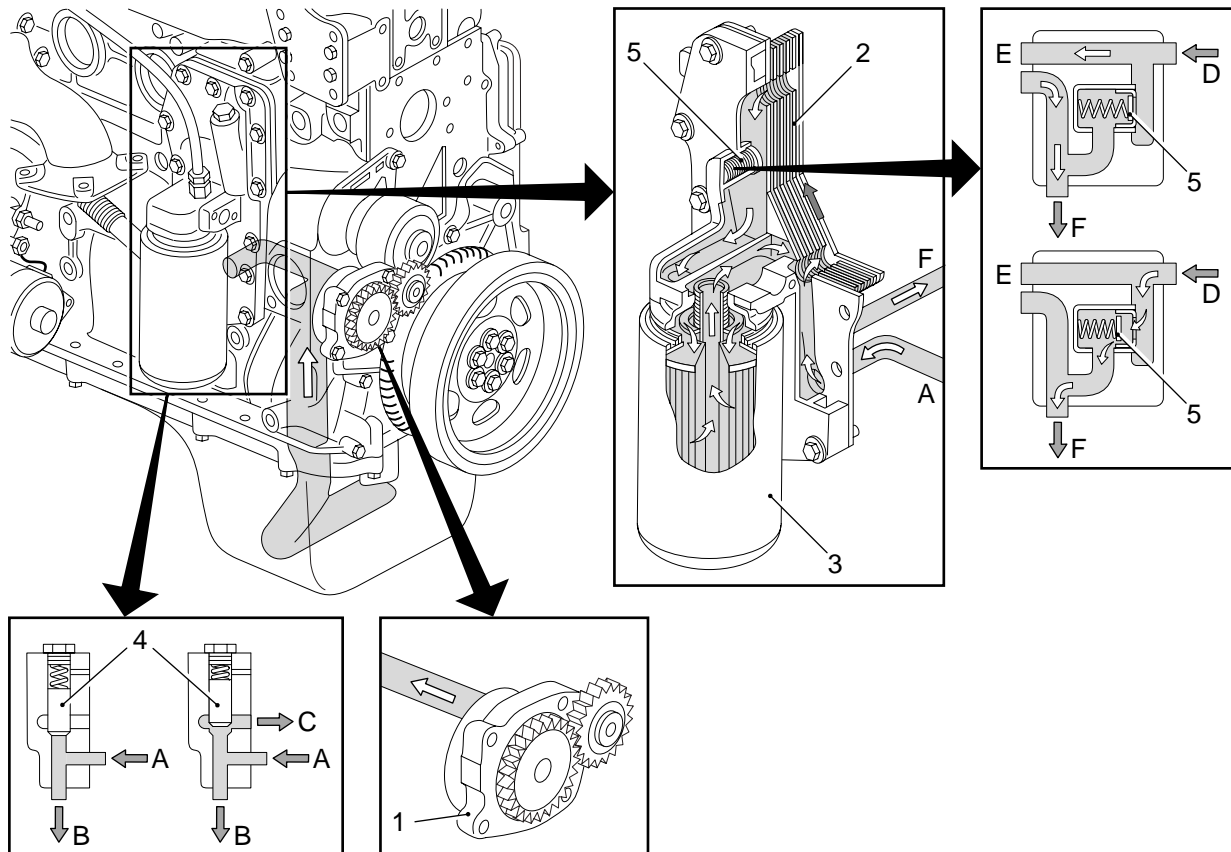

- A From lubricating oil pump
- B To oil cooler
- C To lubricating oil pump
- D From oil cooler
- E To oil filter
- F To main oil channel

M201120

General

The lubricating oil pump (1) is directly driven by the crankshaft via an idler gear.

The lubricating oil pump draws the oil from the oil sump and pumps it via the oil cooler (2) and the lubricating oil filter (3) to the main oil channel in the cylinder block. From the main oil channel, the lubricating oil is further distributed to the various components requiring lubrication.

Oil cooler

The oil cooler (2) is connected to the cooling system. The oil cooler warms up the lubricating oil in a "cold" engine and cools it in a "warm" engine.

Pressure-limiting valve

A pressure limiting valve (4) is fitted in the oil cooler housing.

When the pressure set for the pressure limiting valve has been reached, the valve opens and allows the excess lubricating oil to be discharged to the supply side of the lubricating oil pump.

Oil filter

The oil is cleaned in the disposable oil filter (3). A pressure relief valve (5) fitted in the oil cooler housing opens if the pressure in the filter becomes too high as a result of contamination or cold oil. The oil then passes through the filter unfiltered.

4

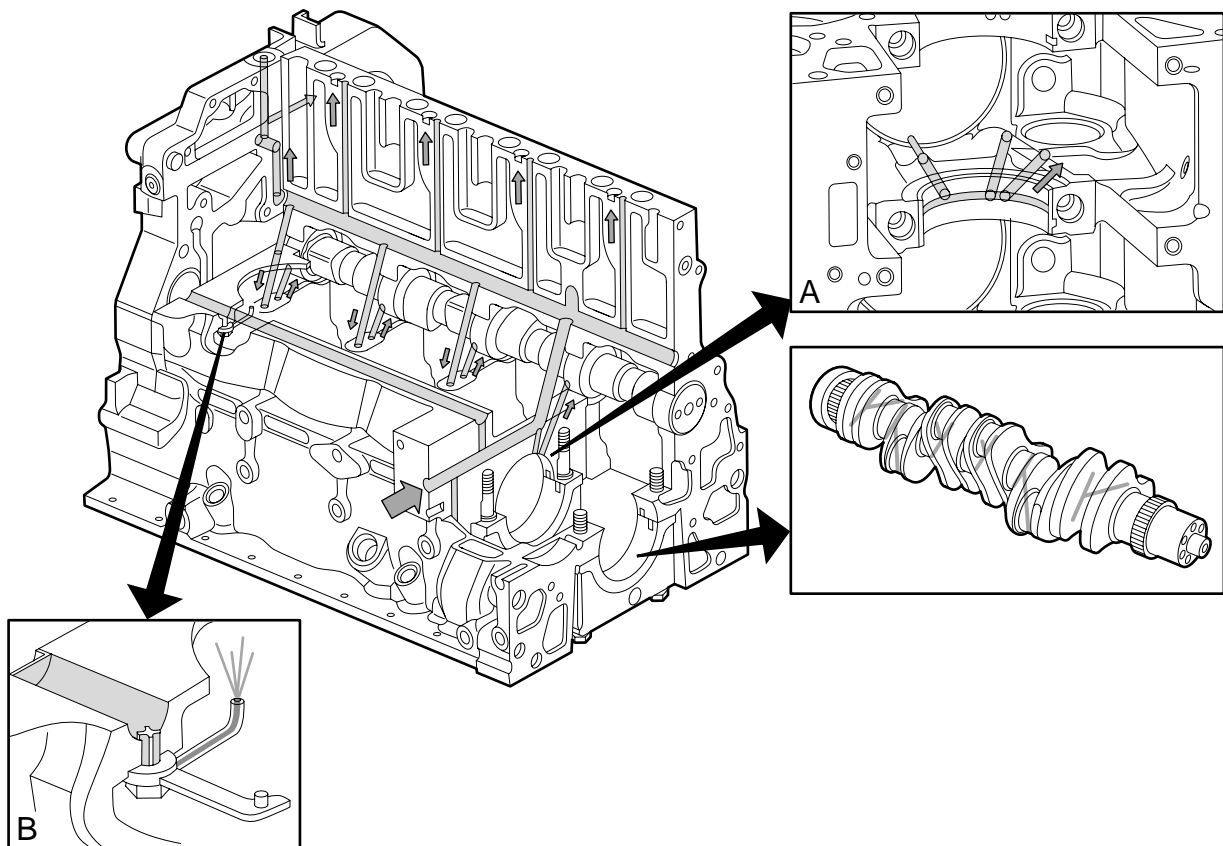

M201260

Main oil channel

From the main oil channel, lubricating oil is supplied to the crankshaft main bearings (A) and via an oil channel in the crankshaft also to the big-end bearings.

From the main oil channel, lubricating oil is pumped to the camshaft.

Cylinder head

From the main oil channel, vertical oil channels pass through the cylinder block to the cylinder head. This bore is continued in the cylinder head to supply lubricating oil to the rockers.

Piston and gudgeon pin

The pistons are lubricated by oil nozzles (B). In addition to its lubricating function, the lubricating oil has an important cooling function. A hole has been drilled at the top of the connecting rod, through which the oil that the oil nozzles spray against the piston head may reach the upper big-end bearing and the gudgeon pin.

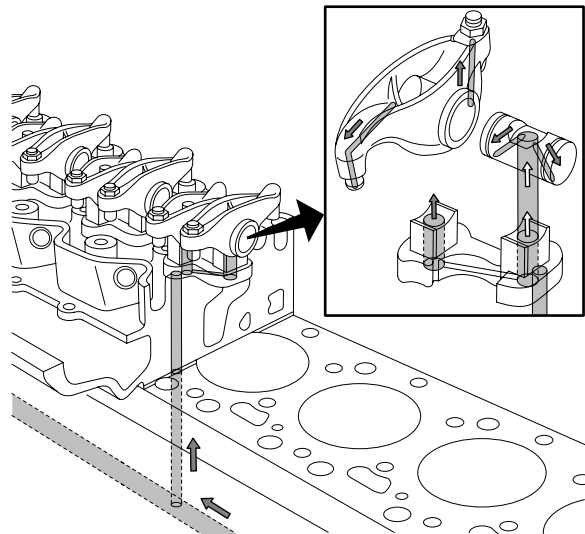

M201123

Turbocharger

The turbocharger is lubricated via an oil pipe from the oil cooler housing.

The oil discharge pipe from the turbocharger is connected to the cylinder block, from where the oil returns to the oil sump.

Air compressor

The air compressor is supplied with oil from an oil channel in the timing gear case connected to the main oil channel.

The oil returning from the air compressor flows from the front of the air compressor to the timing gear case, and from there to the oil sump.

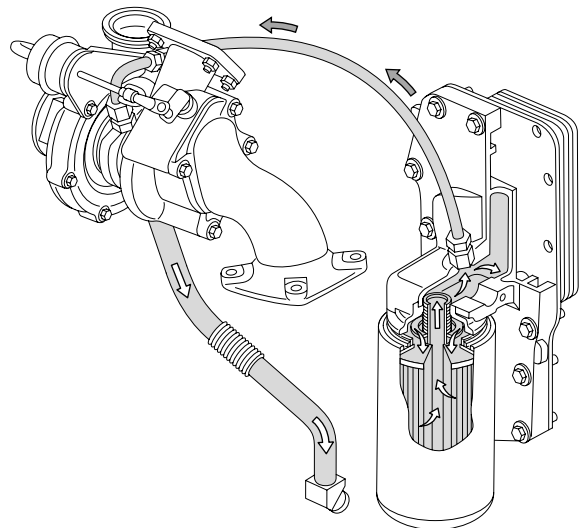

M201122

3. CHECKING AND ADJUSTING

3.1 CHECKING ENGINE OIL CONSUMPTION

Engine oil consumption relates to the engine oil used during combustion in the engine. Since engine oil consumption is affected by driving style and the use to which the vehicle is put, it is also related to average fuel consumption. See "Technical data" for the maximum permissible engine oil consumption.

Test conditions

1. An engine oil consumption test is only meaningful after the engine has been run in (approx. 25,000 km).
2. Check the engine carefully for engine oil leakage before carrying out an engine oil consumption test. First repair any leaks.
3. Check the average fuel consumption and engine oil consumption as accurately as possible.
4. Only check the engine oil level when the engine is at operating temperature and only when the engine has been turned off for five minutes.
5. Make sure the vehicle is horizontal before checking the engine oil level.

3.2 INSPECTION, LUBRICATING OIL PRESSURE

1. Bring the engine up to operating temperature.
2. Remove the plug from the main oil channel. It is located on the left, in the centre of the engine block.
3. Connect the special tool (DAF no. 0535551) to the oil pressure gauge connection.
4. Start the engine and measure the lubricating oil pressure at idling speed and at full-load engine speed. Compare the pressure readings with the technical data. See "Technical data".
5. Stop the engine and remove the oil pressure gauge. Fit a new sealing ring in the plug and insert the plug.

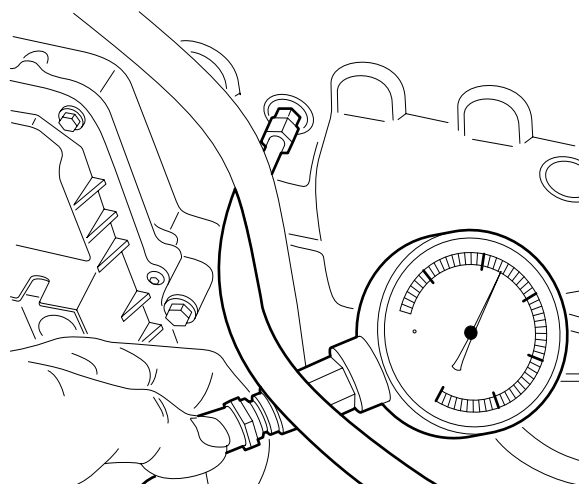

M201150

3.3 PRESSURE-TESTING THE OIL COOLER

1. Remove the oil cooler. See 'Removal and installation'.
2. Fit special tool (DAF no. 1329478) to the oil cooler.
3. Connect an air hose with pressure reducer valve to the special tool.
4. Immerse the oil cooler in warm water and set the specified air pressure. See 'Technical data' for the specified water temperature and the test pressure.
5. Check the cooling element for leakage.

Note:

The oil cooler should be replaced if it is leaking.

6. Remove the special tool.
7. Fit the oil cooler. See 'Removal and installation'.

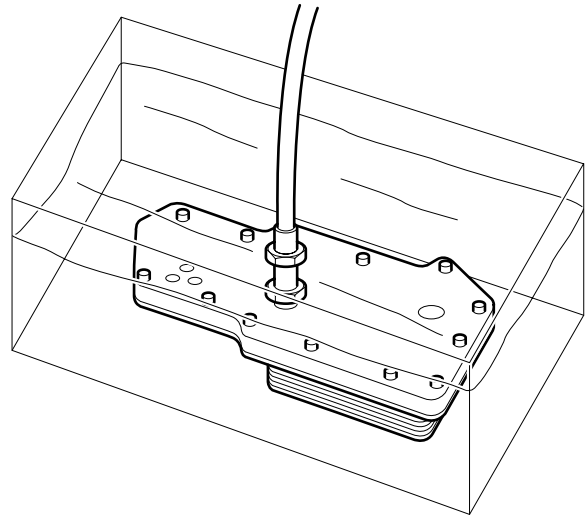

M201154

3.4 INSPECTING THE LUBRICATING OIL PUMP

Inspecting the lubricating oil pump

1. Check the lubricating oil pump drive gears for damage and excessive wear.
2. Check the drive gear backlash. See 'Technical data'.
3. Remove the rear plate from the lubricating oil pump.
4. Check the play between the inner and outer rotors using a feeler gauge. See 'Technical data'.

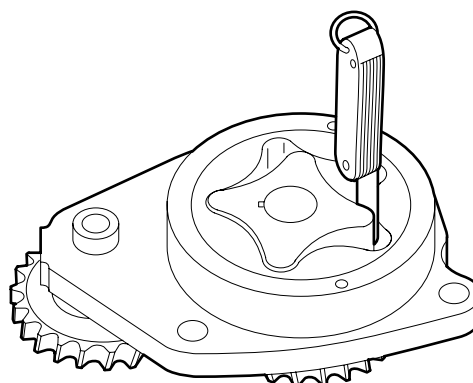

M201077

5. Check the play between the outer rotor and the pump housing using a feeler gauge. See 'Technical data'.

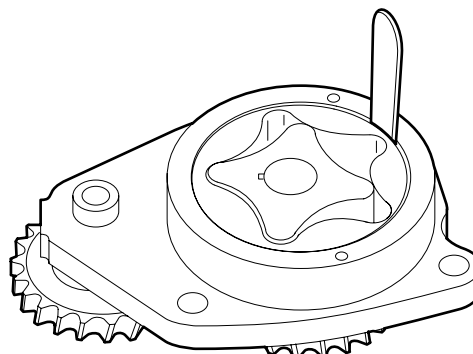

M201076

6. Using a feeler gauge and a straight edge check the play between the inner and outer rotors in relation to the pump housing. See 'Technical data'.
7. Mark the top of the outer rotor and remove the outer rotor.
8. Check the inner rotor and outer rotor for damage and excessive wear.
9. Fit the outer rotor with the marked side upwards.
10. Fit the rear plate.

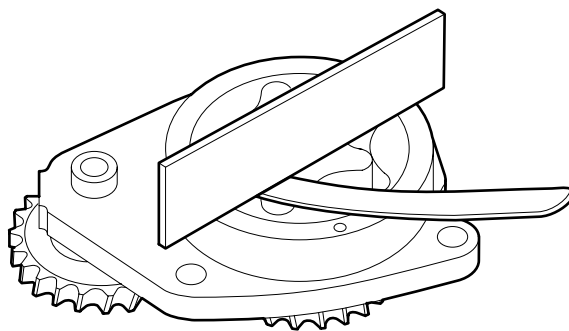

M201075

4. REMOVING AND INSTALLING

4.1 REMOVAL AND INSTALLATION, LUBRICATING OIL FILTER



To prevent skin injury, avoid unnecessary contact with the drained lubricating oil. Be careful when changing the oil. Hot oil may cause serious injuries.

Removing the oil filter

1. Clean the location and the area surrounding the filter element if extremely fouled.
2. Remove the filter element by turning it anti-clockwise. Collect any oil that is flowing out.
3. Remove the O-ring if it has not been removed already.

Installing the oil filter

1. Lightly oil the filter element sealing ring.
2. Fill the filter element with clean oil. Use the specified oil.
3. Fit the filter until the seal abuts, and tighten it by hand another $\frac{3}{4}$ to a full turn.
4. Run the engine for a short time and check whether the oil filter is correctly sealed.
5. Check the oil level and correct if necessary. Use the specified oil.

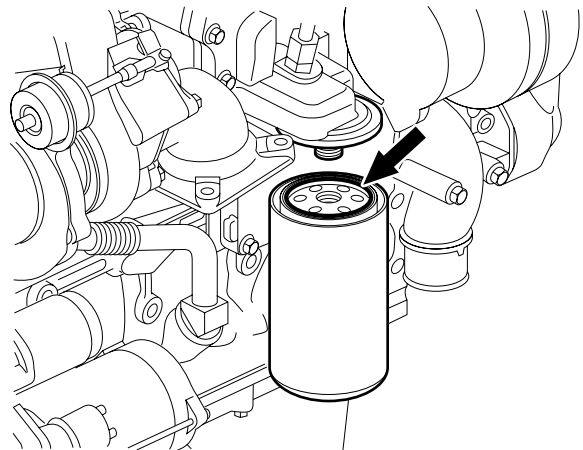

GO 00 207

4.2 REMOVAL AND INSTALLATION, OIL COOLER**Removing the oil cooler**

1. Drain the coolant. See "Draining and filling".
2. Remove the lubricating oil filter.
3. Remove the turbocharger oil supply pipe.
4. Remove the attachment bolts from the oil cooler and remove the oil cooler.

Installing the oil cooler

1. Fit the oil cooler with new gaskets and tighten the attachment bolts to the specified torque and in the specified sequence. See "Technical data".
2. Tighten the oil supply pipe to the specified torque. See "Technical data".
3. Fit the lubricating oil filter.
4. Fill the cooling system.
5. Run the engine briefly, and check that the oil cooler does not leak.
6. Check the lubricating oil level.
7. Check the coolant level.

4.3 REMOVAL AND INSTALLATION, OIL SUMP

Removing the oil sump

1. Drain the engine oil. See "Draining and filling".
2. Support the oil sump.
3. Remove the attachment bolts all around.
4. Remove the oil sump (1) with sealing rubber (2) and flange (3).

Installing the oil sump

1. Thoroughly clean the sealing surfaces of the oil sump and the engine block.
2. Check the oil sump sealing rubber (2). Damaged sealing rubbers must be replaced.
3. Fit the oil sump (1) with sealing rubber (2) and flange (3) upright.
4. Fit the attachment bolts in the specified sequence and tighten them to the specified torque. See "Technical data".
5. Fill the engine with the correct amount of lubricating oil. See "Draining and Filling".
6. Run the engine for a short time and check for oil leaks. Then check the oil level.

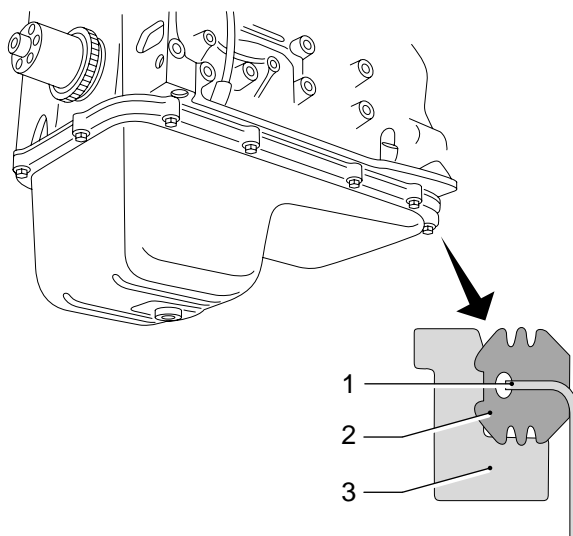

M201139

4.4 REMOVING AND INSTALLING LUBRICATING OIL PUMP

Removing lubricating oil pump

1. Remove the fan.
2. Remove the poly-V-belt.
3. Remove the vibration damper and the crankshaft pulley.
4. Remove the front crankshaft seal.
5. Remove the front engine panel.
6. Remove the attachment bolts from the lubricating oil pump crosswise and remove it.

Installing lubricating oil pump

1. Check the lubricating oil pump. See "Checking and adjusting".
2. Fill the lubricating oil pump with engine oil and position the lubricating oil pump in the cylinder block.
3. Fit the attachment bolts and tighten them crosswise to the specified torque. See "Technical data".

Note:

The rear plate of the lubricating oil pump is at the back of the bore; if the lubricating oil pump is fitted correctly, the flange will not touch the cylinder block.

4. Fit the front engine panel.
5. Fit a new front crankshaft seal.
6. Fit the crankshaft pulley and the vibration damper.
7. Fit the poly-V-belt.
8. Fit the fan.

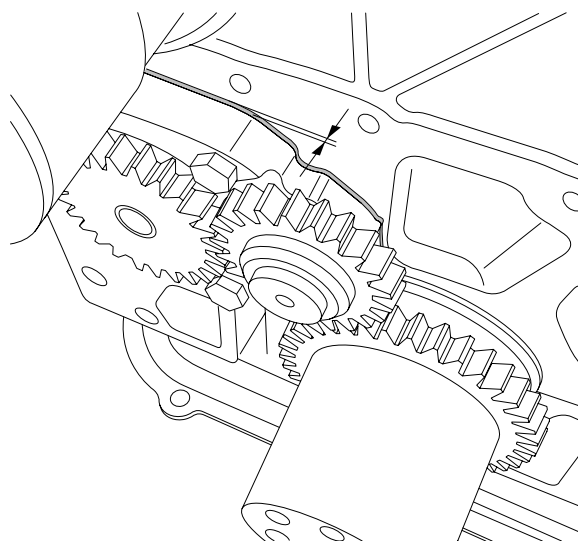

M201124

5. DRAINING AND FILLING

5.1 DRAINING AND REPLENISHING ENGINE OIL



To prevent skin injury, avoid unnecessary contact with the drained oil.

Draining engine oil

1. Ensure that the vehicle is standing on a flat and level surface.
2. Drain the engine oil at operating temperature using the drain plug in the oil sump.
3. Replace the drain plug sealing ring and tighten the drain plug to the specified torque; see "Technical data".

Replenishing engine oil

1. Fill the engine through the oil filler pipe (1) with the specified quantity of engine oil; see "Technical data".
2. Use the dipstick (2) to check the engine oil level.

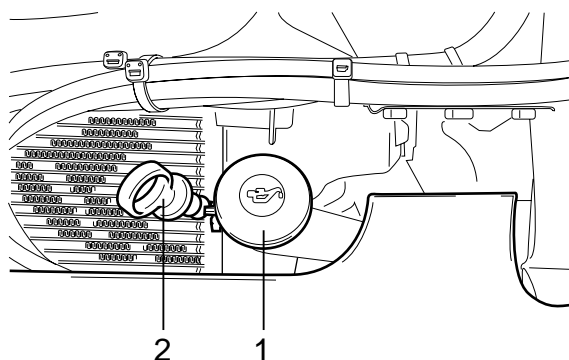

M201433

CONTENTS

	Page	Date
1. SAFETY INSTRUCTIONS	1-1	200505
1.1 Safety instructions	1-1	200505
2. GENERAL	2-1	200505
2.1 Location of components	2-1	200505
2.2 Identification	2-3	200505
2.3 Overview drawing, timing gear	2-4	200505
3. CHECKING AND ADJUSTING	3-1	200505
3.1 Inspection and adjustment, CE engine valve clearance	3-1	200505
3.2 Checking and adjusting timing gear	3-3	200505
3.3 Checking piston projection	3-5	200505
3.4 Checking cylinder head bolts	3-7	200505
3.5 Inspecting the flywheel	3-9	200505
3.6 Inspection, engine oil sump pressure	3-10	200505
3.7 Inspecting the CE engine vibration damper	3-11	200505
3.8 Inspecting the cylinder head	3-12	200505
3.9 Inspecting the cylinder block	3-12	200505
4. REMOVING AND INSTALLING	4-1	200505
4.1 Removal and installation, engine	4-1	200505
4.2 Removal and installation, engine mounts	4-2	200505
4.3 Removal and installation, valve cover	4-4	200505
4.4 Removal and installation, valve sleeve	4-5	200505
4.5 Removal and installation, valve gear	4-7	200505
4.6 Removal and installation, intake manifold	4-8	200505
4.7 Removal and installation, exhaust manifold	4-10	200505
4.8 Removing and installing cylinder head	4-11	200505
4.9 Removal and installation, air compressor	4-15	200505
4.10 Removing and installing steering pump	4-16	200505
4.11 Removal and installation, starter motor	4-18	200505
4.12 Removal and installation, poly-V-belt	4-19	200505
4.13 Removal and installation, alternator	4-20	200505
4.14 Removal and installation, flywheel	4-21	200505
4.15 Removal and installation, starter ring gear	4-22	200505
4.16 Removal and installation, flywheel housing seal	4-23	200505
4.17 Removal and installation, flywheel housing	4-25	200505
4.18 Removal and installation, vibration damper	4-26	200505
4.19 Removal and installation, crankshaft sensor ring	4-27	200505
4.20 Removing and installing front engine panel	4-28	200505
4.21 Removal and installation, camshaft gear	4-29	200505
4.22 Removal and installation, timing gear case	4-31	200505
4.23 Removal and installation, front crankshaft seal	4-33	200505
5. CLEANING	5-1	200505
5.1 Cleaning the engine	5-1	200505

1. SAFETY INSTRUCTIONS

1.1 SAFETY INSTRUCTIONS

Fuel



Diesel fuel is an extremely flammable liquid, and must not be exposed to naked flames or come into contact with hot surfaces. The diesel fuel fumes remaining in an empty fuel tank form an extremely explosive mixture.

When fuel system components are being removed, some fuel will escape. To keep this spillage to a minimum, unscrew the tank cap to release any overpressure.

Any spilled fuel must be collected, bearing in mind the risk of fire.

Exhaust gases

Do not run the engine in an enclosed or unventilated area. Make sure exhaust fumes are properly extracted.



Exhaust gases contain carbon monoxide. Carbon monoxide is a deadly colourless and odourless gas, which, when inhaled, deprives the body of oxygen, leading to asphyxiation. Serious carbon monoxide poisoning may result in brain damage or death.

Moving parts

Remain at a safe distance from rotating and/or moving components.

Various fluids

Various oils and lubricants used on the vehicle may constitute a health hazard. This also applies to engine coolant, windscreen washer fluid, refrigerant in air-conditioning systems, battery acid and clutch fluid. So avoid inhaling and direct contact.

Electrical short-circuit

Always disconnect the battery's earth connection during repair or maintenance operations for which the electric power supply is not required.

2. GENERAL

2.1 LOCATION OF COMPONENTS

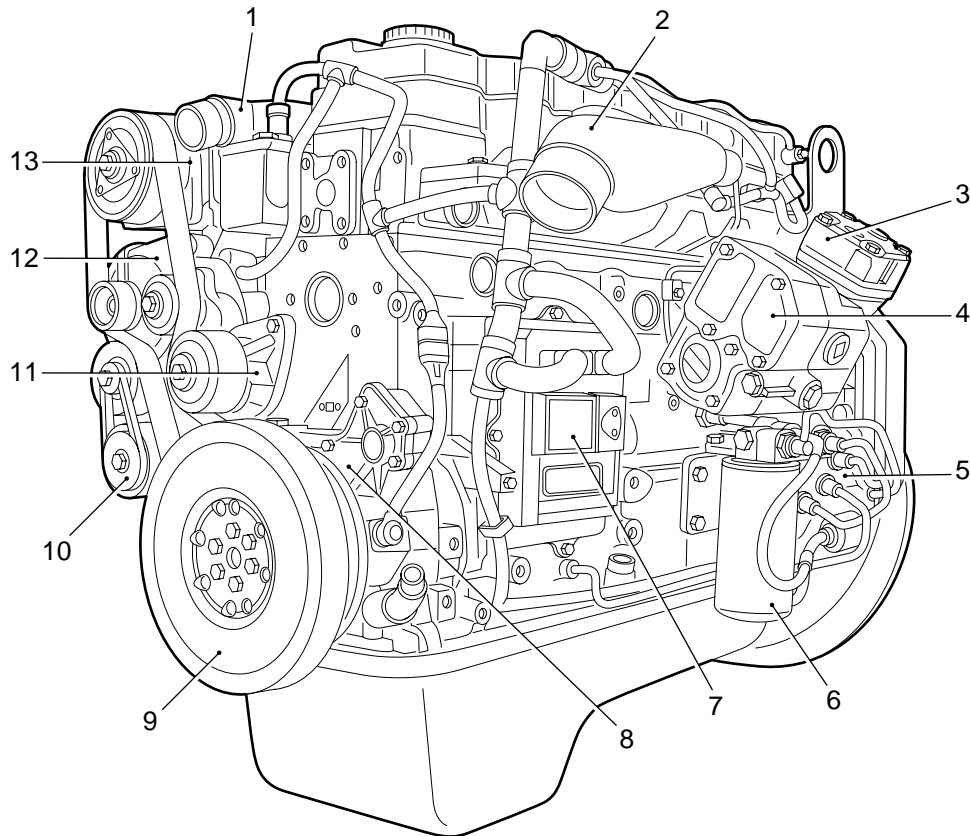

1. Thermostat housing
2. Intake manifold
3. Air compressor
4. Steering pump with reservoir
5. High-pressure pump
6. Fuel filter
7. ECS-DC3 electronic unit
8. Front engine panel
9. Vibration damper
10. Automatic tensioner
11. Coolant pump
12. Alternator
13. Air-conditioning compressor

M201141

5

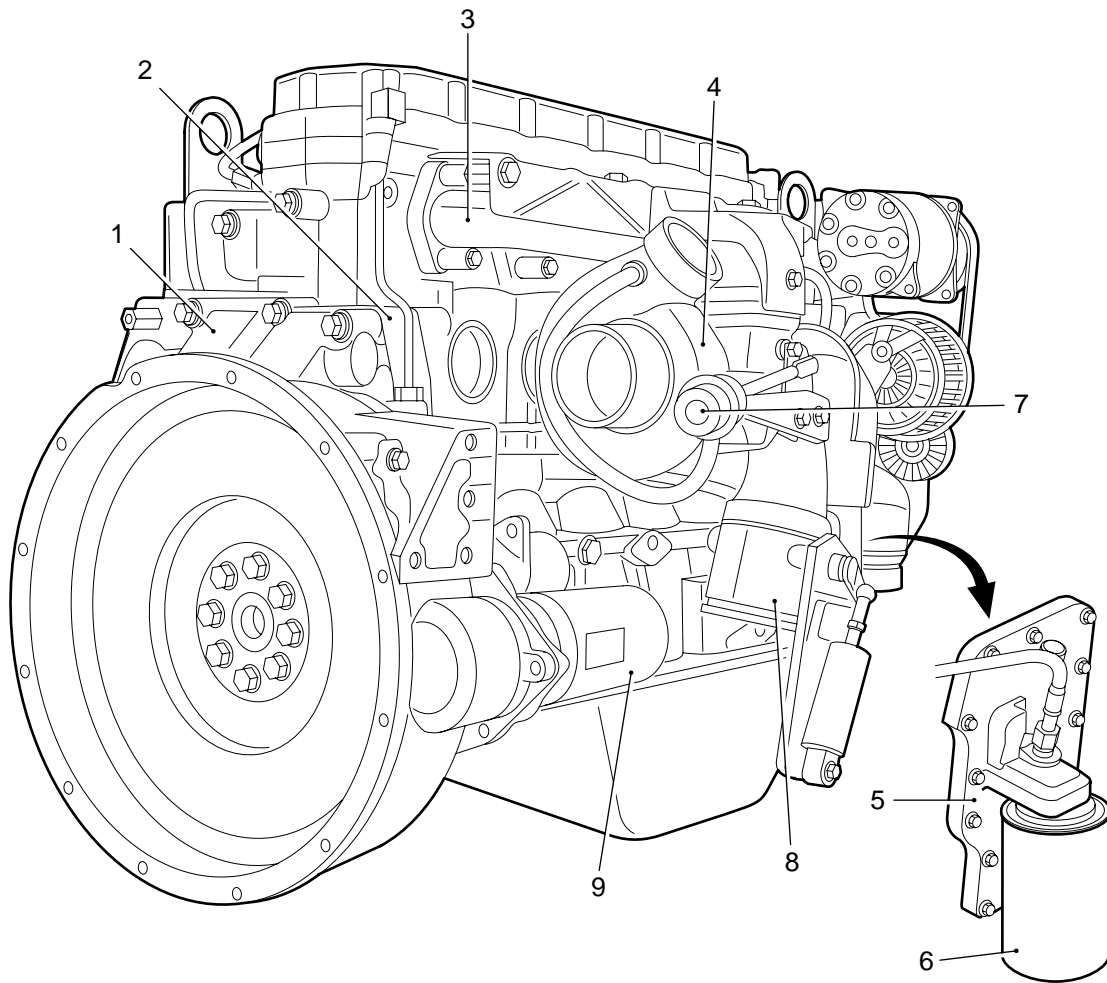

- 1. Flywheel housing
- 2. Timing gear case
- 3. Exhaust manifold
- 4. Turbocharger
- 5. Oil cooler
- 6. Oil filter
- 7. Wastegate diaphragm
- 8. Exhaust brake
- 9. Starter motor

M201140

2.2 IDENTIFICATION

Engine number

The engine number is stamped front right in the cylinder block, at the top of the lubricating oil cooler housing.

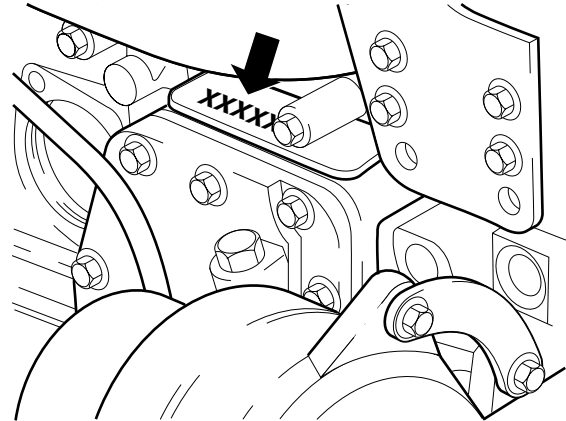

M2 01 138

Engine identification plate

The engine identification plate is located at the top of the flywheel housing or on the valve cover, depending on the production date.

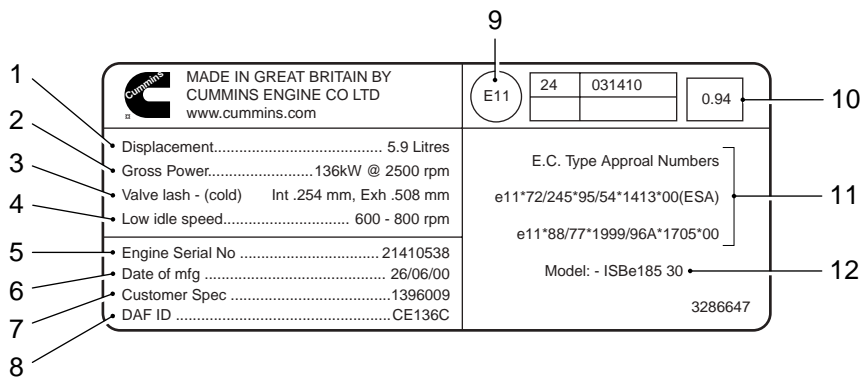

M201135

1. Cubic capacity
2. Engine output
3. Valve clearance
4. Idle engine speed
5. Engine number
6. Production date
7. Client specification
8. DAF type designation
9. Indication of country of origin
10. Free acceleration smoke level (K factor)
11. Type approval numbers
12. Cummins type designation

2.3 OVERVIEW DRAWING, TIMING GEAR

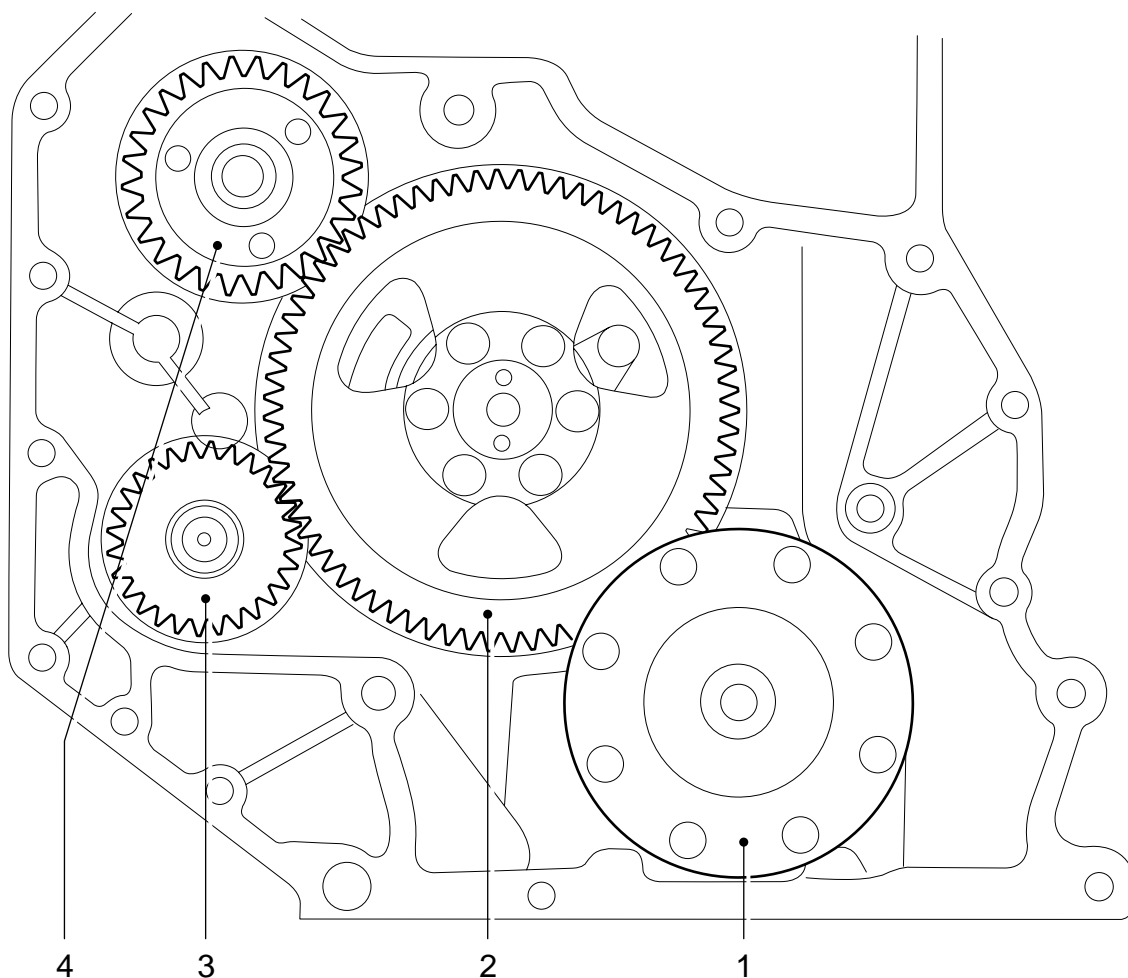

5

- 1. Crankshaft
- 2. Camshaft
- 3. High-pressure pump
- 4. Compressor

M201432

3. CHECKING AND ADJUSTING

3.1 INSPECTION AND ADJUSTMENT, CE ENGINE VALVE CLEARANCE

Note:

Inspection and adjustment of valve clearance must only be carried out when the engine is cold.

1. Remove the valve cover. See 'Removal and installation'.
2. Use an open-end spanner on the fan shaft to turn the crankshaft clockwise, as seen from the vibration damper end (this is the engine's normal direction of rotation), until the mark (A) is between the bolts (B) and the valves of cylinder 1 are in overlap position.

Note:

"Overlap" is the moment at which the inlet valves start opening and the exhaust valves stop closing.

The inlet valves are operated by the short rockers and the exhaust valves by the long rockers.

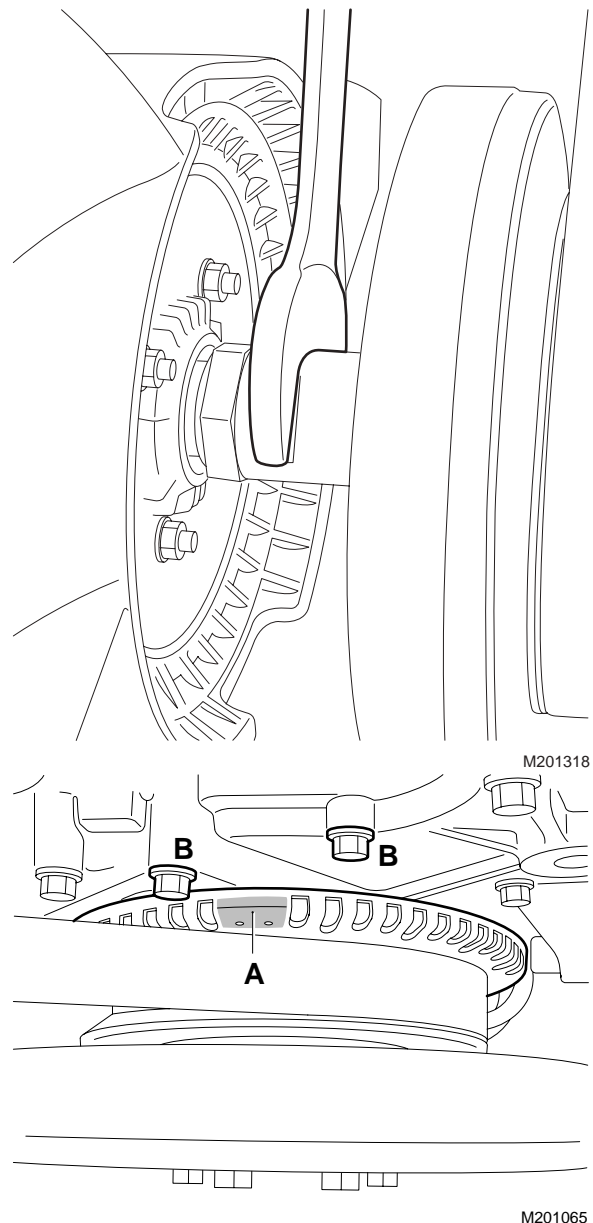

3. Check/correct the valve clearance of the specified inlet and exhaust valves. Set the correct valve clearance by loosening the locknut and rotating the adjusting screw in the correct direction; see "Technical data" for the correct valve clearance.

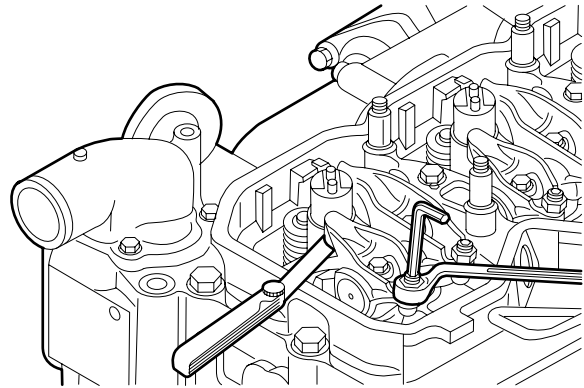

M201064

Cylinder	Inlet valve	Exhaust valve
1		
2		X
3	X	
4		X
5	X	
6	X	X

4. Using an open-end spanner on the fan shaft, turn the crankshaft one rotation further so that the mark (A) is once again between the bolts (B) and the valves of cylinder 6 overlap.
5. Check/correct the valve clearance of the specified inlet and exhaust valves. Set the correct valve clearance by loosening the locknut and rotating the adjusting screw in the correct direction; see "Technical data" for the correct valve clearance.

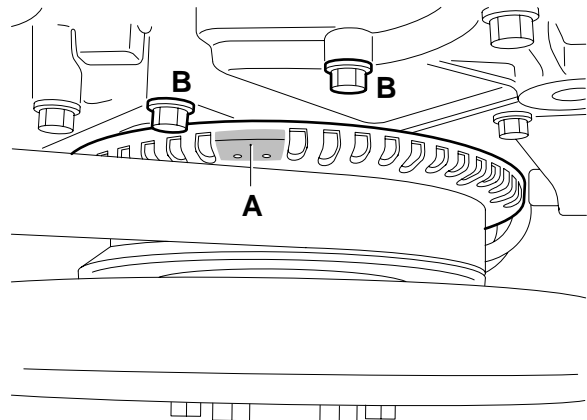

M201065

Cylinder	Inlet valve	Exhaust valve
1	X	X
2	X	
3		X
4	X	
5		X
6		

6. Fit the valve cover. See "Removal and installation".

3.2 CHECKING AND ADJUSTING TIMING GEAR

Note:

The engine is fitted with gears on either side. The gears at the vibration damper end only drive the oil pump. These gears have no marks and may be fitted in any position.

The timing gear wheels on the flywheel side drive the camshaft, air compressor and fuel pump. Only the camshaft gear and the crankshaft gear have marks which must be aligned. The other gears may be fitted randomly.

1. Remove the engine encapsulation panels.
2. Remove the gearbox.
3. Remove the flywheel. See "Removing and installing".
4. Remove the flywheel housing. See "Removing and installing".

Note:

When the engine crankshaft or camshaft is turned separately, the pistons and valves may touch each other.

5. Use an open-end spanner on the fan shaft to turn the crankshaft clockwise, as seen from the vibration damper end, until the marks in the crankshaft gear and camshaft gear match. The crankshaft gear has a punched hole in the tooth which has to fall into the tooth depth of the camshaft gear marked with a punched hole.

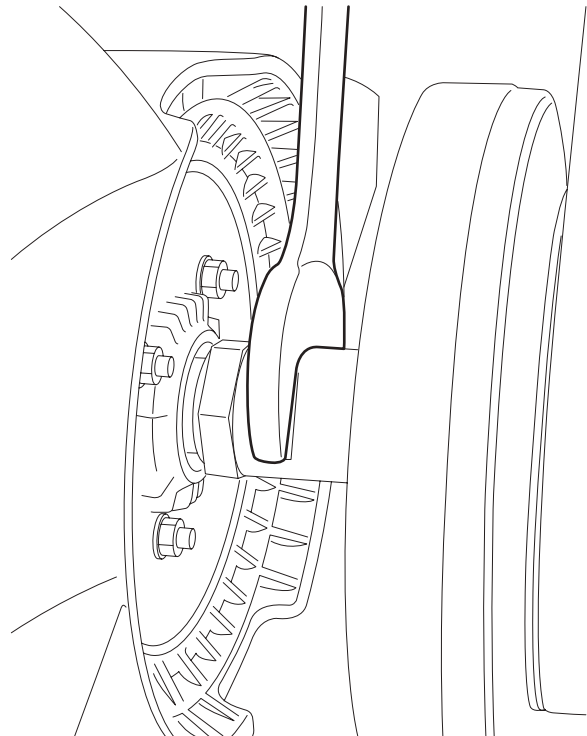

M201318

6. Check that the marked tooth falls exactly into the marked depth. If not, remove and refit the camshaft gear. See "Removing and installing".
7. Fit the flywheel housing. See "Removing and installing".
8. Fit the flywheel. See "Removing and installing".
9. Fit the gearbox.
10. Fit the engine encapsulation panels.

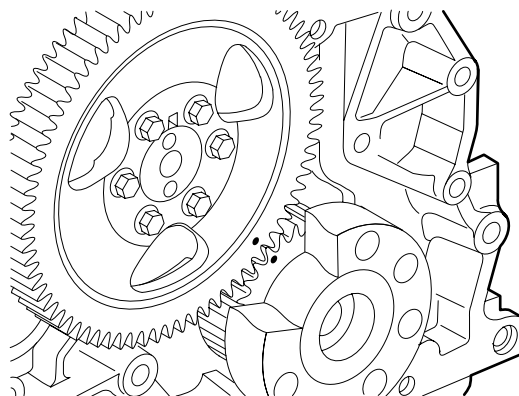

M201146

3.3 CHECKING PISTON PROJECTION

Note:

The piston projection determines which thickness of cylinder head gasket must be used.

1. Use an open-end spanner on the fan shaft to turn the crankshaft, so that the piston of cylinder 1 is in the top dead centre (TDC).
2. Clean the upper surface of the cylinder block and the pistons.

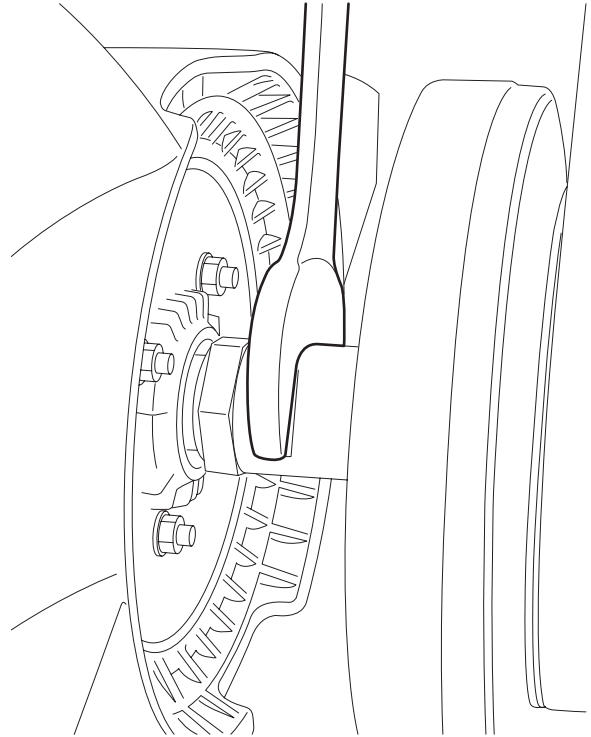

M201318

3. Place a dial gauge on the upper surface of the cylinder block next to cylinder 1 and set the gauge to zero.

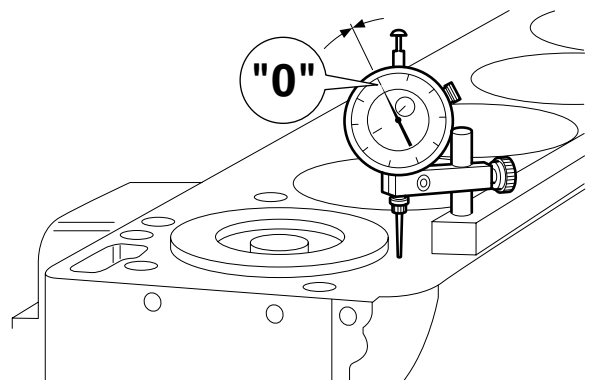

M201233

4. Pull up the stylus of the dial gauge and move it to the edge of the first piston, above the gudgeon pin.
5. Use an open-end spanner on the fan shaft to turn the crankshaft anti-clockwise and clockwise, at the same time reading the dial gauge to find the highest position of the piston. Make a note of this reading.
6. Repeat this measurement for the other pistons.
7. Calculate the average value of the piston projection above the cylinders.

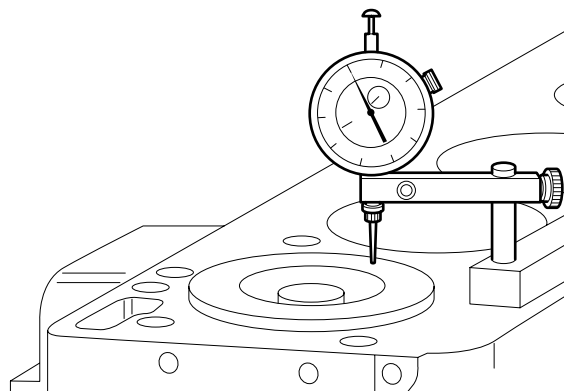

M201234

3.4 CHECKING CYLINDER HEAD BOLTS

Cylinder head bolts can be re-used provided they satisfy a number of conditions. If a cylinder head bolt does not meet one or more of these conditions, new cylinder head bolts must be used.

1. Check cylinder head bolts for damaged screw threads, corroded surfaces and constriction as a result of overstretching.

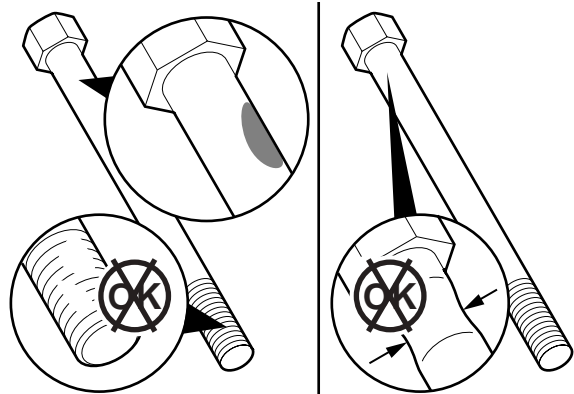

M201248

2. Check the dimensions of visible pitting on the cylinder head bolt, see "Technical data".

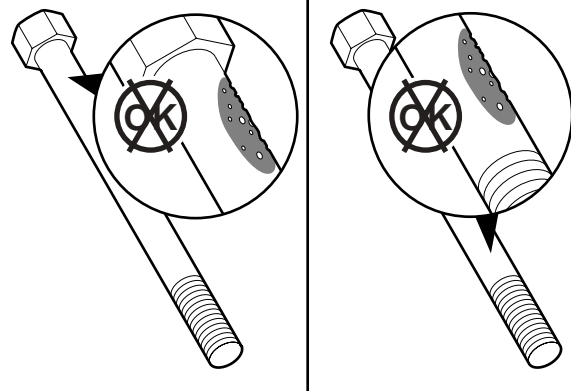

M201249

3. Check the cylinder head bolt for visible corrosion or pitting immediately under the bolt head and directly above the start of the screw thread, see "Technical data".

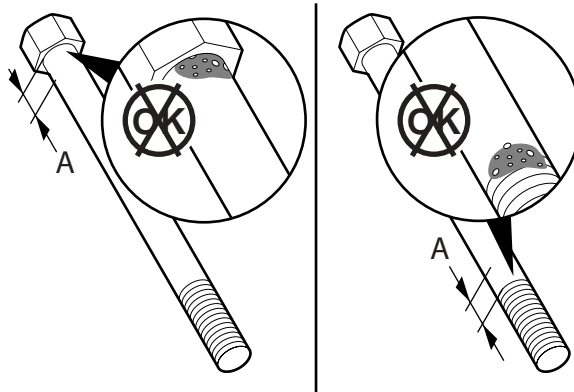

M201250

- 4. Check the free length of the cylinder head bolt. Use the special tool (DAF no. 1329477) for this purpose. Place the bolt head against the abutting surface.

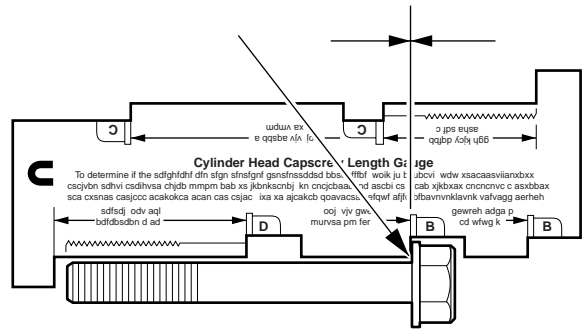

M201251

- 5. The end of the bolt must not touch the gauge.

5

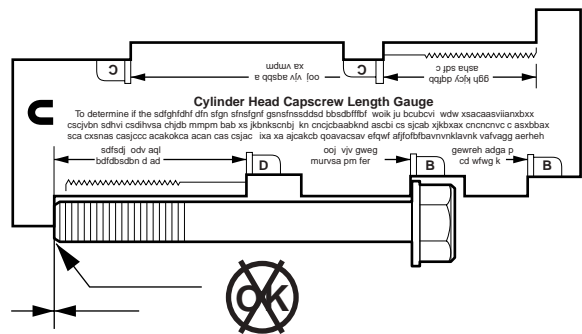

M201252

3.5 INSPECTING THE FLYWHEEL

If cracks are visible on the flywheel, on the contact surface of the clutch plate, it must be replaced.

Checking flywheel run-out

1. Clean the flywheel.
2. Place a metal strip on the edge of the flywheel housing to fit a dial gauge.
3. Place the dial gauge on the metal strip.
4. Place the stylus of the dial gauge as close as possible to the outer edge of the flywheel.
5. Set the dial gauge to "0".

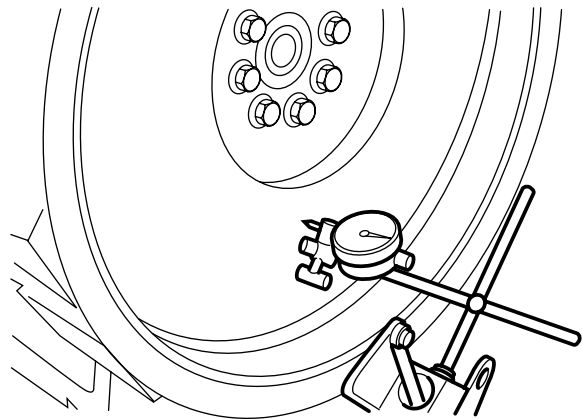

M200230

6. Use an open-end spanner on the fan shaft to crank the engine through 360°, and measure the maximum dial gauge reading. Compare the reading with the specified value, see 'Technical data'.

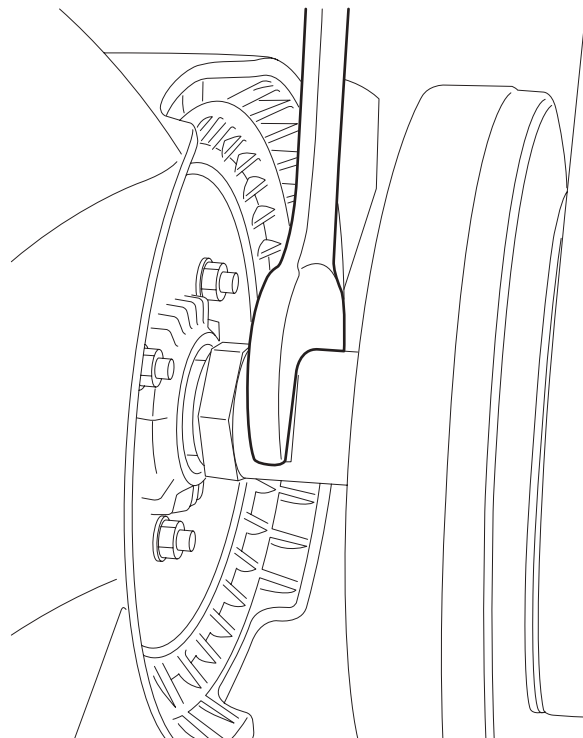

M201318

3.6 INSPECTION, ENGINE OIL SUMP PRESSURE



Be careful when working on an engine at operating temperature.

The oil sump pressure is measured to quickly check the cylinder seals. The readings obtained are an indication of the leakage from all cylinders.

1. Bring the engine up to operating temperature.
2. Turn off the engine and fit the special tool (DAF no. 1240080) (1) to the crankcase breather hose.
3. Fit the special tool with a water pressure gauge (DAF no. 1240081) (2) using a hose and start the engine.
4. Using the water pressure gauge, measure the oil sump pressure at idling speed and compare the measured reading with the technical data. See "Technical data".

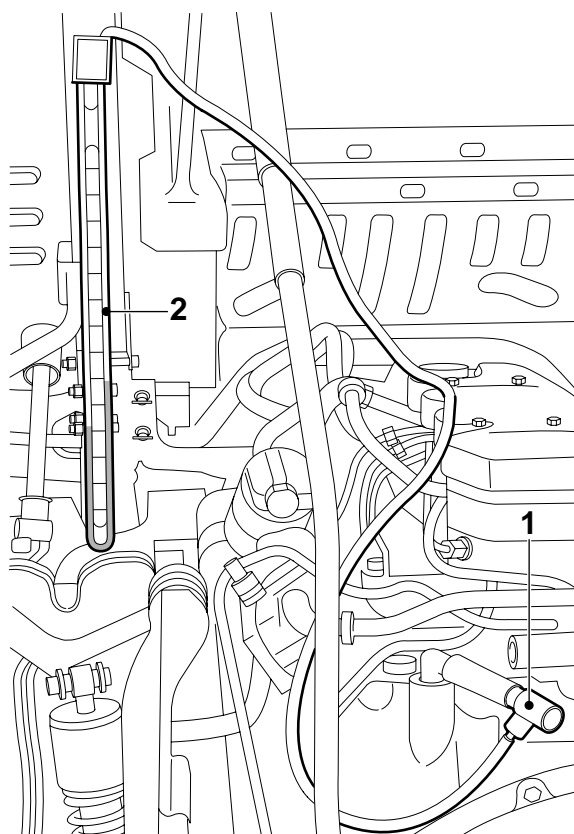

M201316

3.7 INSPECTING THE CE ENGINE VIBRATION DAMPER

Note:

The viscous vibration damper is filled with a silicone liquid. After some time this silicone liquid may expand.

1. Remove the paint at four places on either side of the vibration damper.
2. Measure the thickness at these four places at a distance of 80 mm from the outer edge. Compare the reading with the technical data. See 'Technical data'.

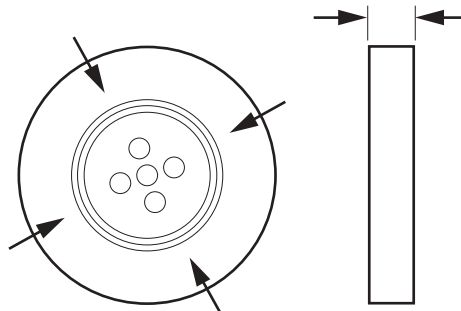

M201394

3.8 INSPECTING THE CYLINDER HEAD

1. Check the sealing plugs and expansion plugs of the cylinder head for leaks. If necessary, pressure-test the cylinder head.
2. Inspect the cylinder head for damage to the sealing surface and any cracks.
3. Check the cylinder head for smoothness using a straight edge and feeler gauge. See "Technical data".

Note:

The cylinder head must be replaced if it does not meet the specified values.

5**3.9 INSPECTING THE CYLINDER BLOCK**

1. Inspect the cylinder block for damage to the sealing surface and any cracks.
2. Check the cylinder block for smoothness using a straight edge and feeler gauge. See "Technical data".

4. REMOVING AND INSTALLING

4.1 REMOVAL AND INSTALLATION, ENGINE



Suspend the engine securely from the hoist, using approved lifting gear.

Various fluids will be released when fluid pipes are removed.

Collect these fluids. Personal safety and the risk of fire should always be considered.

Note:

Because of the large number of vehicle specifications, it is not feasible to exactly specify the engine removal and installation procedures for every vehicle.

This description only includes the most important points requiring attention.

- Disconnect the earth lead from the battery terminal.
- Avoid opening fluid systems as much as possible. If possible, remove and set aside the engine components.
- When removing the engine, ensure that no parts or dirt fall into the engine, radiator or other components. All openings that are freed should therefore be plugged.
- Wiring harnesses are vulnerable. If damaged, they may cause failures. Make sure these wiring harnesses are not live and are clear of moving parts.
- Fit all attachment bolts and tighten them to the correct torque.
- The engine should not be allowed to rest on the oil sump. Because the oil sump is made of sheet material, it will be severely damaged by the engine's weight.
- The engine should not be allowed to rest on the flywheel housing. It can easily be damaged by the engine's weight.

4.2 REMOVAL AND INSTALLATION, ENGINE MOUNTS



Suspend the engine securely from the hoist, using approved lifting gear. Various fluids will be released when fluid pipes are removed. Collect these fluids. Personal safety and the risk of fire should always be considered.

Removing the engine mounts

1. Disconnect the earth lead from the battery terminal.
2. Drain the coolant.
3. Remove the hoses between the engine and the radiator.
4. Remove the attachment bolts from the radiator torque rod bracket on the engine side.
5. Remove the air inlet hoses between the engine and the air cooler. Plug the openings.
6. Detach the air-conditioning pipes, if present, at the top of the radiator.
7. Detach the heater hose bracket at the top of the radiator.
8. Remove the oil supply pipe from the engine.
9. Remove the lower connector from electronic unit ECS-DC3.
10. Remove the attachment bolts of the viscous fan clutch on the drive flange and place the viscous fan clutch with the fan in the wind tunnel.
11. Suspend the engine securely in the hoist.
12. Remove the engine mount attachment bolts at the front and rear of the engine.
13. Hoist the engine very carefully as far as necessary and support it properly.
14. Remove the engine mounts.

Installing the engine mounts

1. Tighten the engine mounting attachment bolts to the specified torque. See "Technical data".
2. Fit the viscous fan clutch with the fan. Tighten the attachment bolts to the specified torque. See "Technical data".
3. Fit the connector of electronic unit ECS-DC3.
4. Fit the oil supply pipe.
5. Fit the heater hose bracket at the top of the radiator.
6. Fit the bracket for the air-conditioning pipes at the top of the radiator.
7. Fit the torque rod bracket between the engine and the radiator.
8. Fit the air inlet hoses between the engine and the air cooler.
9. Fit the coolant hoses between the engine, radiator and the header tank.
10. Fit the torque rod between the radiator and the engine.
11. Fill the cooling system. See "Draining and filling".
12. Connect the battery earth lead.

4.3 REMOVAL AND INSTALLATION, VALVE COVER



When the engine or parts thereof are opened, dirt may enter. This may cause serious damage to the engine. The engine should therefore be cleaned thoroughly before it is opened.

Removing the valve cover

1. Clean the area around the valve cover.
2. Remove the banjo bolt and the attachment of the plastic crankcase breather tube.
3. Remove the valve cover attachment nuts.
4. Remove the valve cover.

Installing the valve cover

1. Clean the sealing surface of the valve sleeve and the valve cover.
2. Check the valve cover gasket. If it is not damaged it may be re-used.
3. Fit the valve cover gasket to the valve cover.
4. Fit the valve cover.
5. Fit the attachment nuts of the valve cover and tighten them to the specified torque. See "Technical data".
6. Fit the plastic crankcase breather tube and the banjo bolt to the valve cover.

4.4 REMOVAL AND INSTALLATION, VALVE SLEEVE



When the engine or parts thereof are opened, dirt may enter. This may cause serious damage to the engine. The engine should therefore be cleaned thoroughly before it is opened.

Removing the valve sleeve

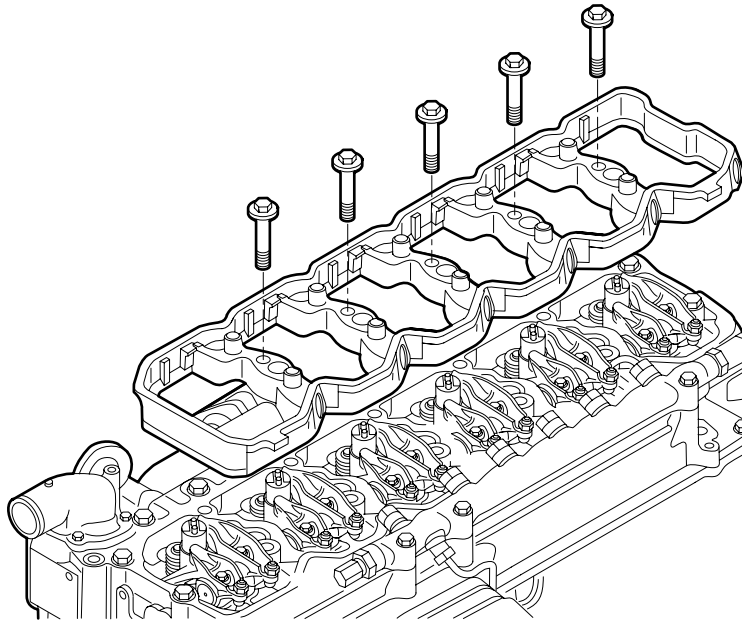

M201422

1. Remove the valve cover.
2. Detach the feed-through connectors from the injectors.
3. Remove the wiring from the injectors.
4. Remove the attachment bolts from the valve sleeve.
5. Remove the valve sleeve with the gasket.

Installing the valve sleeve

1. Clean the sealing surface of the cylinder head and valve sleeve.
2. Check the valve sleeve gasket. If it is undamaged, it may be re-used. Fit the valve sleeve gasket onto the valve sleeve.
3. Fit the valve sleeve.
4. Tighten the valve sleeve attachment bolts to the specified torque. See "Technical data".



Tightening the injector wiring to a higher torque than specified may cause damage to the injector.

5. Fit the injector wiring on the injectors and tighten it to the specified torque. See "Technical data".
6. Fit the feed-through connectors of the injectors.
7. Fit the valve cover.

4.5 REMOVAL AND INSTALLATION, VALVE GEAR

Removing the valve gear

1. Remove the valve cover.
2. Loosen the lock nuts on the valve stem bolts and unscrew the bolts until they abut.
3. Remove the rocker seat attachment bolts.

Note:

Number the rocker seats so that they can be refitted in their original position.

4. Remove the rocker seats with the rockers.
5. Remove the bridges.

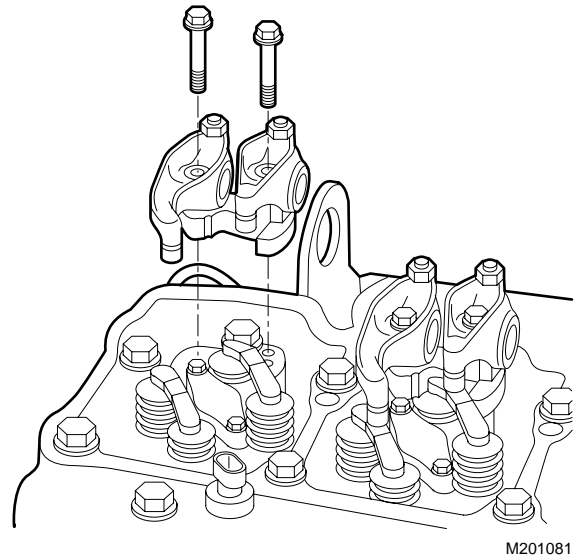

Installing the valve gear

1. Check that the push rods are in the correct position in the valve tappets and apply a drop of engine oil to the push rod cavity.
2. Fit the bridges on the valves.
3. Fit the push rods in their original position.
4. Hand-tighten the rocker seats and rockers in their original position.
5. Tighten the attachment bolts to the specified torque. See "Technical data".
6. Adjust the valve clearance. See "Inspection and adjustment".
7. Fit the valve cover.

4.6 REMOVAL AND INSTALLATION, INTAKE MANIFOLD

Removing the intake manifold

1. Remove the hose from the intake manifold coming from the intercooler.
2. Detach the electric wiring from the glow elements (1) (if fitted) using the connectors.
3. Remove the fuel rail.

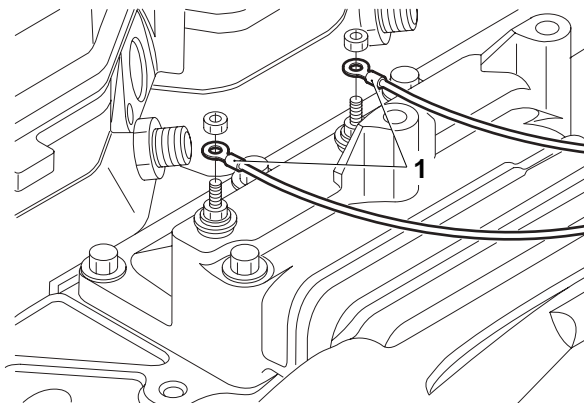

i400521

4. Remove the inlet air boost pressure sensor/temperature sensor (1) from the intake manifold.
5. Remove the intake manifold (2).
6. Cover the open inlet duct from the cylinder head to prevent the ingress of foreign matter.

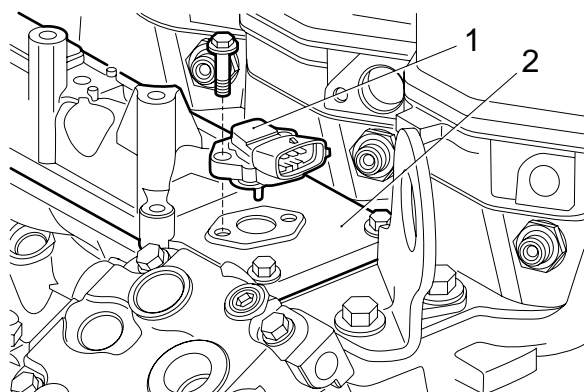

M201395

Installing the intake manifold

1. Thoroughly clean the sealing surfaces of the intake manifold and the cylinder head. Do not let any particles fall into the open inlet duct in the cylinder head.
2. Apply a bead (2) of sealant to the sealing surfaces from the cylinder head to the intake manifold (1). See "Technical data".
3. Fit the intake manifold immediately and tighten the attachment bolts to the specified torque. See "Technical data".
4. Fit the inlet air boost pressure sensor/temperature sensor on the intake manifold.
5. Fit the fuel rail.
6. Connect the electric wiring to the glow elements (if fitted) using the connectors (1).
7. Fit the hose to the intake manifold coming from the intercooler.

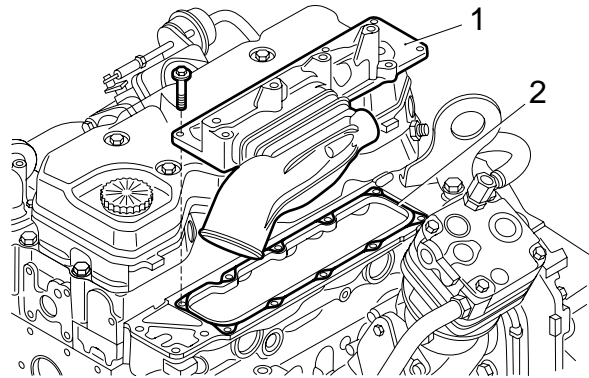

M201396

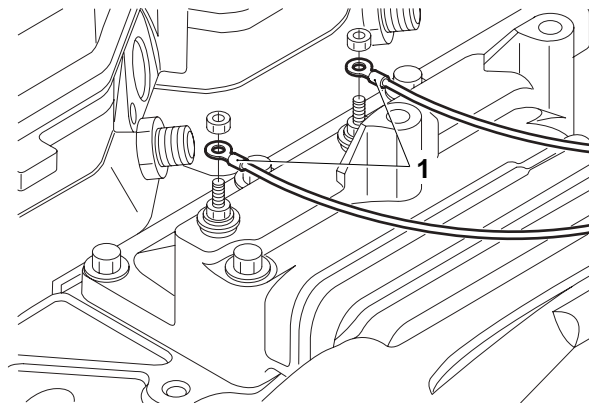

i400521

4.7 REMOVAL AND INSTALLATION, EXHAUST MANIFOLD

Removing the exhaust manifold

1. Remove the heat shields from the exhaust manifold.
2. Remove the turbocharger.
3. Remove the exhaust manifold (1) and gaskets.

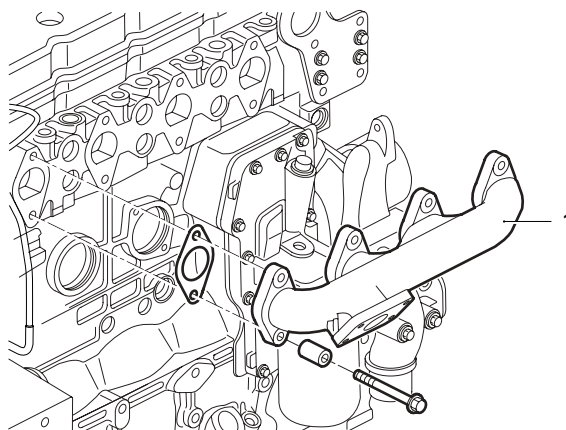

i400524

Installing the exhaust manifold

1. Check the surface of the exhaust manifold for smoothness with a steel ruler (1) and feeler gauge (2). Compare the reading with the values listed in 'Technical data'.
2. Fit new gaskets to the exhaust manifold and install the manifold. Tighten the attachment bolts, from the middle outwards alternately. For the specified tightening torque, see 'Technical data'.
3. Fit the turbocharger.
4. Install the heat shields to the exhaust manifold and tighten the attachment bolts to the specified torque. See 'Technical data'.

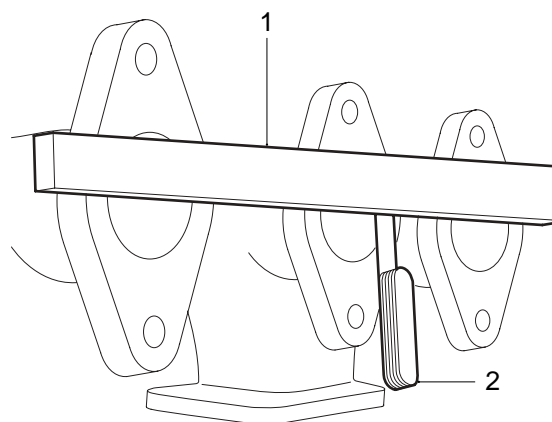

M201397

4.8 REMOVING AND INSTALLING CYLINDER HEAD



When components are removed from any part of the engine, dirt may enter. This may cause serious damage to the engine. The engine should therefore be cleaned thoroughly before it is opened. Plug all openings that are freed.

Removing cylinder head

1. Drain the coolant.
2. Disconnect all electrical wiring around the engine which is required for removing the cylinder head.
3. Disconnect the air inlet pipe from the air cooler on the turbocharger side.
4. Remove the poly-V-belt.
5. Remove the heat shields from the exhaust manifold.
6. If fitted, remove the attachment bolts of the air-conditioning compressor.
7. Remove the attachment bolts from the alternator/air-conditioning compressor bracket and remove the attachment bracket.
8. Remove the attachment bolts from the exhaust manifold and move the manifold and the turbocharger a little away from the cylinder head.
9. Remove the other coolant hoses that are attached to the cylinder head.



When removing components from the fuel system, dirt can enter. This may result in serious damage. The area around the fuel system should therefore be cleaned before opening it. Detached pipes must be plugged immediately.

10. Detach the injector pipes on the injector side.
11. Detach the supply pipe between the high-pressure pump and fuel rail on the fuel rail side.
12. Detach the fuel return pipe from the fuel rail and from the cylinder head.

13. Unscrew the attachment bolts from the fuel rail and remove it.
14. Unscrew the attachment bolts from the intake manifold and remove it.

Note:

To avoid dirt entering the intake opening, it must be taped up.

15. Remove the valve cover.
16. Remove the valve sleeve.
17. Remove the valve gear.
18. Remove the push rods. Mark the push rods so that they can be refitted in their original position.
19. Remove the fuel supply pipes.
20. Remove the injectors.
21. Remove the attachment bolts from the cylinder head in the reverse order to that followed for tightening. See "Technical data".
22. Remove the cylinder head from the cylinder block. Keep the gasket to enable the correct new head gasket to be selected.
23. Remove any gasket remnants from the cylinder head and the cylinder block.
24. Check the cylinder block. See "Checking and adjusting".
25. Check the threaded holes in the cylinder block for damage and cracking.
26. Check the cylinder head. See "Checking and adjusting".

Installing cylinder head

1. Clean the threaded holes in the cylinder head using a screw tap.

Note:

Cylinder head gaskets are available in two thicknesses. The thickness of the cylinder head gasket can be identified by the position of the holes in the projecting cylinder head gasket lip under the exhaust manifold on cylinder 2. See "Technical data" for the cylinder head gasket thicknesses.

2. Position the new cylinder head gasket. If the type of cylinder head gasket is known, use a gasket of the same type as the one removed.

Note:

If the type of cylinder head gasket removed is not known or if the main components of the driving gear have been changed, the type of gasket required must be determined afresh.

To do this, measure the average piston projection. See "Checking and adjusting". Select the correct type of cylinder head gasket using the information in "Technical data" and fit it.

3. Check that all lubricating and coolant ducts are free.
4. Position the cylinder head carefully on the cylinder block and ensure that the cylinder head fits well over the dowel pins.
5. Check the cylinder head bolts. See "Checking and adjusting". Use new cylinder head bolts if one bolt does not meet one or more conditions.
6. Apply engine oil to the thread and to the underside of the bolt head.
7. Position the cylinder head bolts and hand-tighten them.

Note:

The short cylinder head bolts must be fitted in the outer rows.

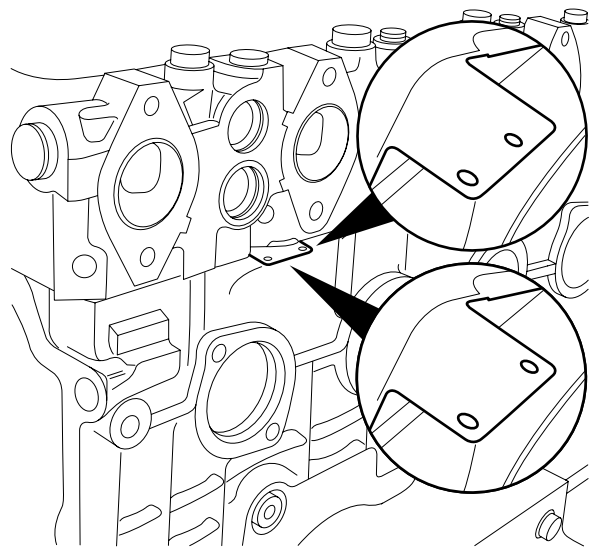

M201230

8. Tighten the cylinder head bolts to the specified torque and in the sequence shown. See "Technical data".
9. Fit the exhaust manifold with new gaskets and tighten the attachment bolts to the specified torque. See "Technical data".
10. Fit the injectors.

Note:

Ensure that the injector is fitted correctly, bearing in mind the supply opening.

11. Fit the fuel supply pipes.
12. Fit the push rods in their original position and apply a drop of engine oil to the head of the push rod.
13. Fit the valve gear.
14. Fit the valve sleeve.
15. Tighten the injector wiring to the specified torque. See "Technical data".
16. Fit the valve cover.
17. Remove any gasket remnants from the intake manifold and the cylinder head.

Note:

Ensure that the air inlet is free of gasket remnants.

18. Apply sealant to the intake manifold and fit it. See "Technical data".
19. Fit the fuel rail.
20. Fit the injector pipes.
21. Fit the supply pipe between the high-pressure pump and fuel rail.
22. Fit the fuel return pipe on the fuel rail and cylinder head.
23. Connect the various coolant hoses.

24. Fit the bracket of the alternator/air-conditioning compressor.
25. If present, fit the air-conditioning compressor.
26. Fit the poly-V-belt.
27. Fit the heat shields.
28. Fit the air inlet pipe of the air cooler on the turbocharger side.
29. Connect the electrical wiring.

4.9 REMOVAL AND INSTALLATION, AIR COMPRESSOR

Removing the air compressor

1. Partially drain the coolant.
2. Remove the steering pump.
3. Remove the coolant pipes.
4. Remove the air pipes.
5. Remove the attachment bolts from the air compressor and remove it.
6. Remove the O-ring from the compressor housing.

Installing the air compressor

1. Fit the compressor with a new O-ring and tighten the attachment bolts to the specified torque. See "Technical data".
2. Fit the air pipes.
3. Fit the coolant pipes.
4. Fit the steering pump.
5. Fill the cooling system.

4.10 REMOVING AND INSTALLING STEERING PUMP

Note:

When replacing a worn steering pump, you are advised to fully drain the steering oil and replace the steering oil reservoir and integrated filter. In extreme situations, the steering pump may have been worn to such an extent that metal pump parts have entered the steering box. Check the steering box for internal wear using the test case.

Removing steering pump

1. Clean the line connections.
2. Place a receptacle underneath the steering pump.
3. Remove the lines from the steering pump and plug the line and pump openings. The filter is fitted in the return line, which means that should any dirt enter it will immediately also enter the steering gear.
4. Remove the attachment bolts and remove the steering pump (3) and the driver (1) from the compressor.
5. Remove the reservoir (4) from the pump (3).

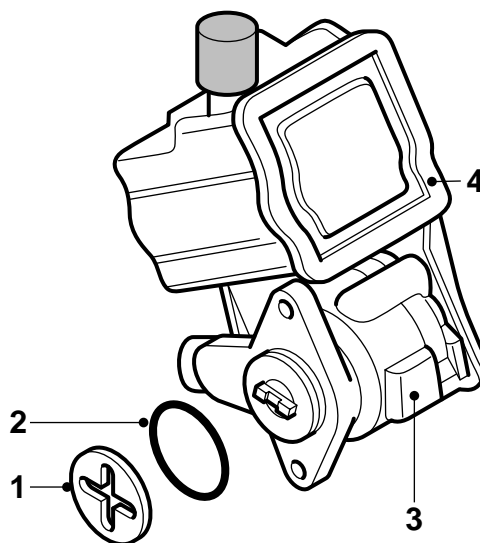

S7 00 575

Installing steering pump

1. If necessary, fit the bracket (2) on top of the new pump. Do not remove the cover from the pump to do this. Tighten the attachment bolts (1) evenly to the specified torque. See "Technical data".

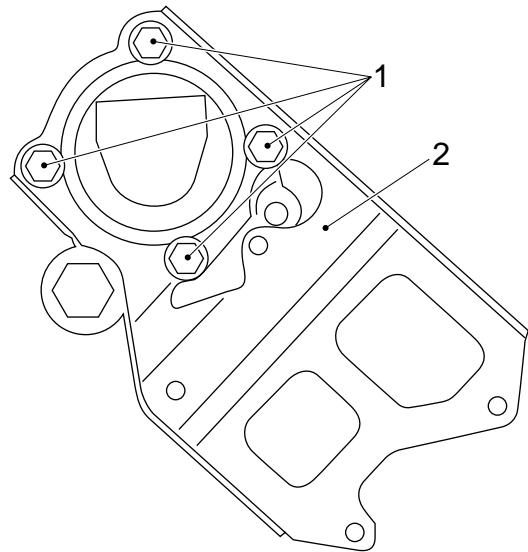

S7 00 609

2. Check the driver (1) for wear.
3. If necessary, connect the line couplings to the steering pump to be fitted. Tighten the couplings to the specified torques; see "Technical data".



If the specified tightening torques are exceeded, the aluminium pump housing may be damaged.

4. Fit a new O-ring (2) on the steering pump and grease it lightly.
5. Crank the engine until the compressor driver half is horizontal.
6. Grease the driver (1) lightly and fit it to the compressor driver half.
7. Fit the reservoir (4) on the pump.
8. Fit the pump (3). Tighten the attachment bolts evenly to the specified tightening torque; see "Technical data".
9. Fit the lines.
10. Fill and bleed the steering gear hydraulic system.
11. Take a test drive and check the pump and line connections for leaks.

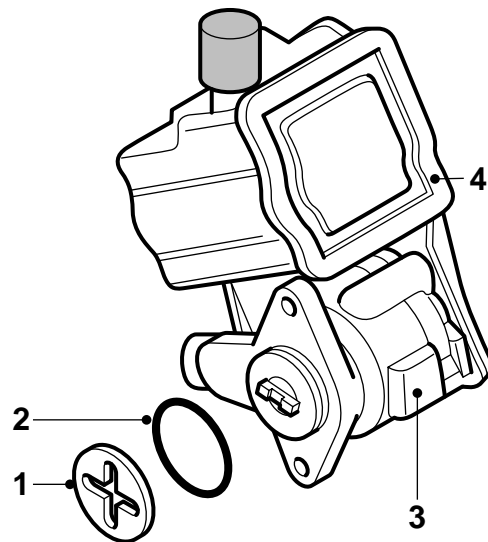

S7 00 575

4.11 REMOVAL AND INSTALLATION, STARTER MOTOR**Removing the starter motor**

1. Remove both battery leads from the battery terminals.
2. Remove the electrical connections from the starter motor.
3. Remove the attachment nuts from the starter motor and remove the starter motor.
4. Check the starter pinion for damage.

Installing the starter motor

1. Clean the contact surfaces of the starter motor and the flywheel housing.
2. Install the starter motor in the flywheel housing and tighten the attachment nuts to the specified torque. See "Technical data".
3. Fit the electrical connections of the starter motor.
4. Reconnect both leads to the battery terminals.

4.12 REMOVAL AND INSTALLATION, POLY-V-BELT

Removing the poly-V-belt

1. Remove the battery terminal clamp from the negative terminal of the starter battery and break the contact.
2. Put a ratchet with a $\frac{3}{8}$ " socket (A) in the arm (B) of the belt tensioner and slacken the belt so that it can be removed from the belt pulleys. Carefully let the belt tensioner expand to the stop.
3. Remove the poly-V-belt (C), lifting it over the fan.

Installing the poly-V-belt

1. Inspect the pulleys for damage, rust and grease deposits. Clean or replace the belt pulleys if necessary.
2. Fit the poly-V-belt over the fan.
3. Place a ratchet with a $\frac{3}{8}$ " socket in the arm of the belt tensioner and push the belt against the spring pressure so that it can be placed on all belt pulleys. Carefully let the belt tensioner spring back until the belt is tensioned.

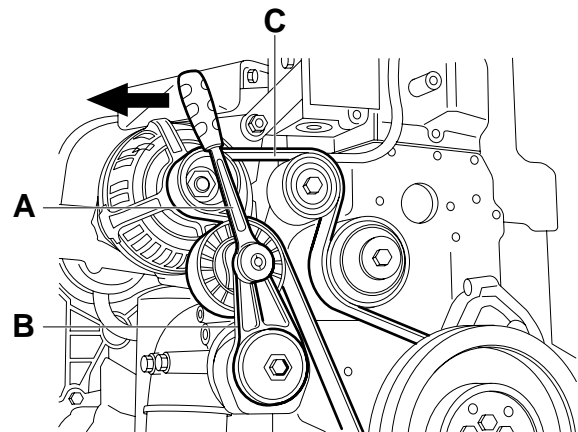

M201430

4.13 REMOVAL AND INSTALLATION, ALTERNATOR**Removing the alternator**

1. Remove both battery leads from the battery terminals.
2. Remove the alternator electrical connections.
3. Remove the poly-V-belt.
4. Remove the attachment bolts from the alternator and remove it.

Installing the alternator

1. Fit the alternator and tighten the attachment bolts to the specified torque. See "Technical data".
2. Fit the poly-V-belt.
3. Fit the alternator electrical connections.
4. Reconnect both leads to the battery terminals.

4.14 REMOVAL AND INSTALLATION, FLYWHEEL

Removing the flywheel

1. Remove the gearbox.
2. Remove the clutch release assembly and the clutch plate.
3. Remove the attachment bolts from the flywheel.
4. To guide the flywheel during removal, fit two threaded ends - each approx. 90 mm - to the now-empty bolt holes.
5. Place two bolts in the circumference of the flywheel and carefully pull the flywheel free.

Installing the flywheel

1. Clean the flywheel housing.
2. Clean the crankshaft flange and attachment bolts.
3. Clean the rear of the flywheel and inspect it. See "Inspection and adjustment".
4. Fit the flywheel.
5. Apply a drop of engine oil to the attachment bolts and install them. Tighten the attachment bolts in a crosswise sequence to the specified torque. See "Technical data".
6. Fit the clutch plate and the clutch release assembly.
7. Fit the gearbox.

4.15 REMOVAL AND INSTALLATION, STARTER RING GEAR**Removing the starter ring gear**

1. Remove the flywheel.
2. Remove the starter ring gear by tapping it off the flywheel, using a blunt chisel. If this is not possible, cut the starter ring gear between two teeth, using a sharp chisel.

Installing the starter ring gear

1. Clean the flywheel and the starter ring gear. Ensure that the contact areas are free of grease.
2. Heat the new starter ring gear evenly in an oven. See "Technical data".
3. Tap the starter ring gear onto the flywheel so that the bevelled sides of the teeth point towards the starter motor. Ensure that the starter ring gear is properly fitted to the flywheel.
4. Fit the flywheel.

4.16 REMOVAL AND INSTALLATION, FLYWHEEL HOUSING SEAL

Removing the flywheel housing seal

1. Remove the gearbox.
2. Remove the clutch release assembly and the clutch plate.
3. Remove the flywheel.
4. Fit the threaded spindle (2) of the special tool (DAF no. 1329475) on the crankshaft flange.
5. Screw the push/pull piece (1) onto the spindle up to the flywheel housing.

Note:

Mark the drill at a length of 22 mm using a piece of tape.

6. Drill a hole through the base plate to the tape marking and fit a screw in the seal to keep the base plate in its place.
7. Drill the other five holes and fit screws.
8. Turn the threaded spindle (2) clockwise until the seal has been removed.

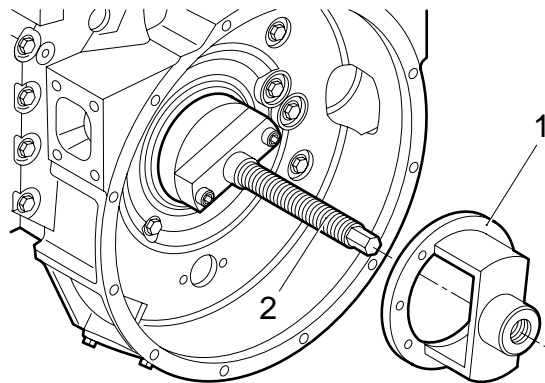

M201068

Installing the flywheel housing seal

1. Clean and inspect the seal chamber. Even minimal damage may cause a leak.
2. Fit the threaded spindle (2) of the special tool (DAF no. 1329475) on the crankshaft flange.
3. Put a new seal over the crankshaft.
4. Screw the push/pull piece (1) onto the threaded spindle (2) up to the seal.
5. Turn the threaded spindle (2) anti-clockwise until the push/pull piece (1) is level with the flywheel housing. The seal has been properly fitted once it is level with the flywheel housing.
6. Remove the special tool.
7. Fit the flywheel.
8. Fit the clutch plate and the clutch release assembly.
9. Fit the gearbox.

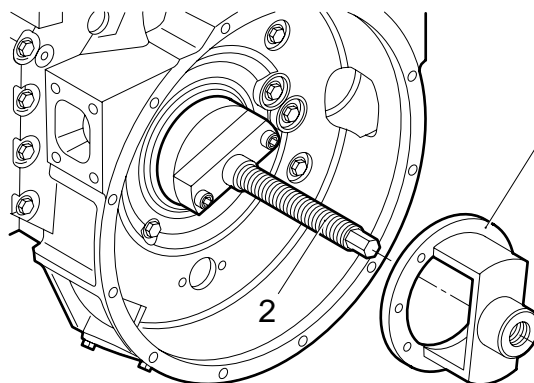

M201068

4.17 REMOVAL AND INSTALLATION, FLYWHEEL HOUSING

Removing the flywheel housing

1. Remove the starter motor.
2. Remove the flywheel.
3. Remove the flywheel housing seal.
4. Suspend the engine securely in the hoist.
5. Remove the engine brackets.
6. Detach the crankcase breather on the flywheel housing so that the attachment bolt can be accessed.
7. Remove the flywheel housing attachment bolts.
8. Remove the flywheel housing.

Installing the flywheel housing

1. Remove any gasket remnants from the contact areas.
2. Check the sealing surfaces for damage.
3. Check the flywheel housing for cracks.
4. Apply a sealant to the sealing face of the cylinder block. See "Technical data". Apply the sealant with a roller or brush evenly over the entire sealing face.
5. Install the flywheel housing and tighten the attachment bolts in the correct sequence to the specified torque. See "Technical data".
6. Fit the engine brackets.
7. Fit the flywheel housing seal.
8. Fit the flywheel.
9. Fit the starter motor.

4.18 REMOVAL AND INSTALLATION, VIBRATION DAMPER**Removing the vibration damper**

1. Remove the attachment bolts of the fan and place the fan in the wind tunnel.
2. Remove the poly-V-belt.
3. Remove the attachment bolts from the vibration damper and remove it.

Installing the vibration damper

1. Check the vibration damper. See "Inspection and adjustment".
2. Fit the vibration damper and tighten the attachment bolts to the specified torque. See "Technical data".
3. Fit the poly-V-belt.
4. Fit the fan.

4.19 REMOVAL AND INSTALLATION, CRANKSHAFT SENSOR RING

Removing the crankshaft sensor ring

1. Remove the attachment bolts from the viscous fan clutch and place the fan in the wind tunnel.
2. Remove the poly-V-belt.
3. Remove the attachment bolts from the vibration damper.
4. Remove the vibration damper and the crankshaft sensor ring.

Installing the crankshaft sensor ring

1. Fit the crankshaft sensor ring with vibration damper and tighten the attachment bolts to the specified torque. See "Technical data".

Note:

There is only one way of fitting the crankshaft sensor ring. For this purpose, a pin has been fitted which fits into a bore in the crankshaft sensor ring.

2. Fit the poly-V-belt.
3. Fit the fan and tighten the attachment bolts to the specified torque. See "Technical data".

4.20 REMOVING AND INSTALLING FRONT ENGINE PANEL

Removing front engine panel

1. Remove the poly-V-belt.
2. Remove the attachment bolts from the vibration damper and remove the damper along with the crankshaft pulley.
3. Remove the front crankshaft seal.
4. Remove the attachment bolts from the front engine panel and remove it.

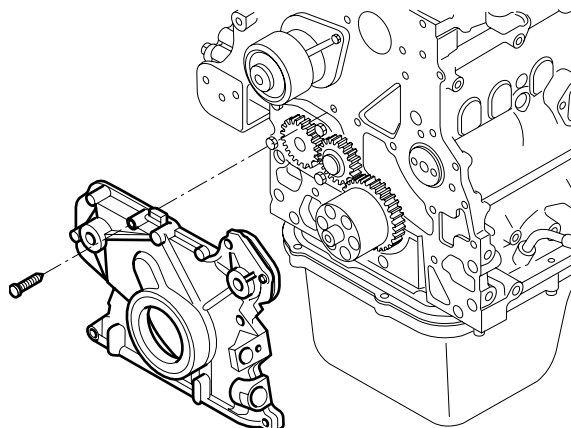

M201157

Installing front engine panel

1. Remove any gasket remnants from the contact areas.
2. Check the sealing surfaces for damage.
3. Check the engine panel for cracks.
4. Apply a sealant to the sealing surface of the cylinder block. See "Technical data". Apply the sealant with a roller or brush evenly over the entire sealing surface.
5. Fit the engine panel and tighten the attachment bolts to the specified torque. See "Technical data".
6. Fit a new front crankshaft seal.
7. Fit the crankshaft pulley and the vibration damper. Tighten the attachment bolts to the specified torque. See "Technical data".
8. Fit the poly-V-belt.

4.21 REMOVAL AND INSTALLATION, CAMSHAFT GEAR

Removing the camshaft gear

1. Remove the flywheel housing.
2. Use an open-end spanner on the fan shaft to crank the crankshaft until the marks in the crankshaft gear and camshaft gear match. The crankshaft gear has a punched hole in the tooth which has to fall into the tooth depth of the camshaft gear marked with a punched hole.
3. Remove the air compressor.

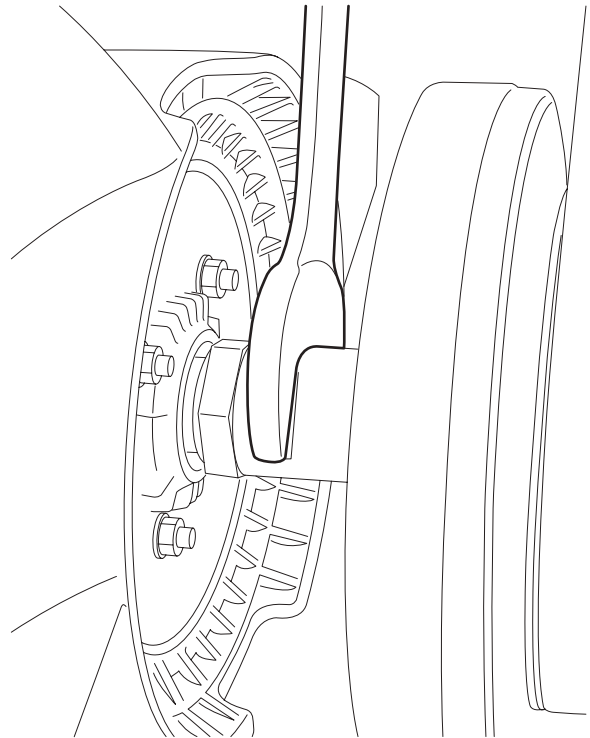

M201318

4. Remove the attachment bolts from the camshaft gear and remove it.

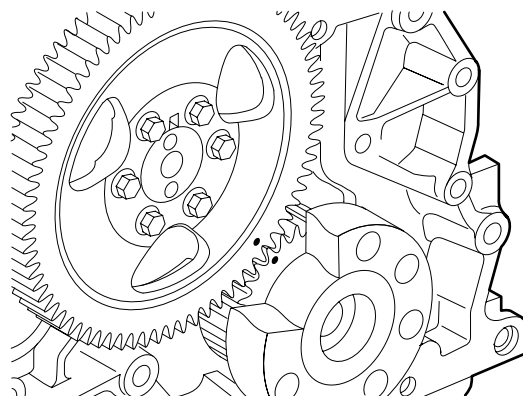

M201146

Installing the camshaft gear

1. Fit the camshaft gear making sure that the timing gear is properly set. See 'Inspection and adjustment'.

Note:

There is only one way of fitting the camshaft gear. For this purpose, a recess has been made which falls over a pin on the camshaft.

2. Tighten the attachment bolts to the specified torque. See 'Technical data'.
3. Fit the air compressor.
4. Fit the flywheel housing.

4.22 REMOVAL AND INSTALLATION, TIMING GEAR CASE

Removing the timing gear case

1. Remove the flywheel housing.
2. Remove the steering pump.
3. Remove the air compressor.
4. Remove the high-pressure pump.
5. Use an open-end spanner on the fan shaft to crank the crankshaft until the marks in the crankshaft gear and camshaft gear match. The crankshaft gear has a punched hole in the tooth which has to fall into the tooth depth of the camshaft gear marked with a punched hole.
6. Remove the camshaft gear.
7. Loosen the sump bolts and remove the sump bolts fitted in the timing gear case.

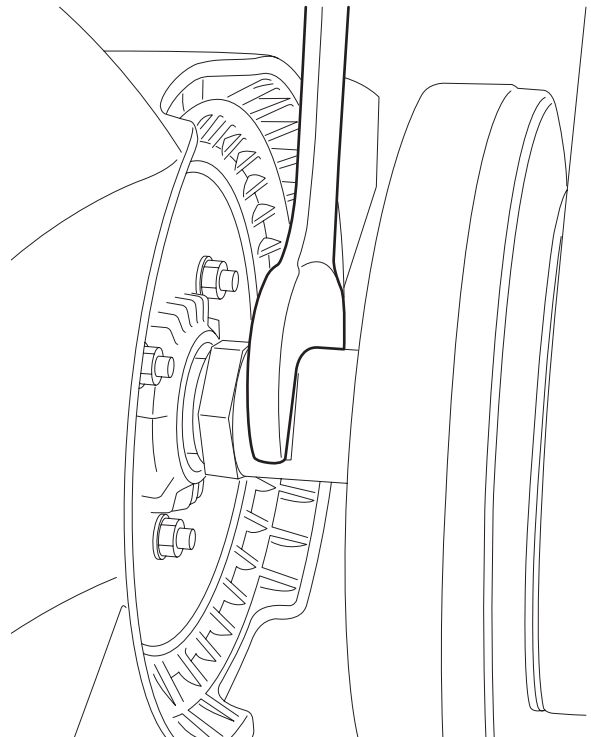

M201318

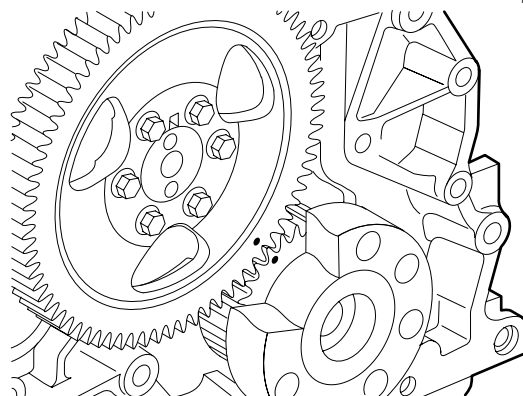

M201146

8. Remove the attachment bolts from the timing gear case and remove it.

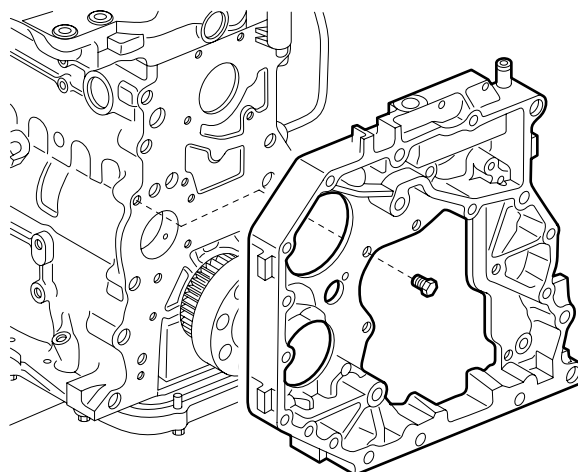

M201147

5

Installing the timing gear case

1. Apply a sealant to the sealing surface of the cylinder block. See "Technical data". Apply the sealant in accordance with the pattern and at the indicated location. The bead has to be 1.5 to 2.0 mm thick. Fit the timing gear case with liquid sealant and tighten the attachment bolts to the specified torque. See "Technical data".

Note:

If too much sealant is used, or if the sealant is applied in a wrong place, this may cause obstruction of an oil channel or oil sump ventilating duct. This could result in serious damage.

2. Fit the sump bolts and tighten them to the specified torque. See "Technical data".
3. Fit the camshaft gear.
4. Fit the high-pressure pump.
5. Fit the air compressor.
6. Fit the steering pump.
7. Fit the flywheel housing.

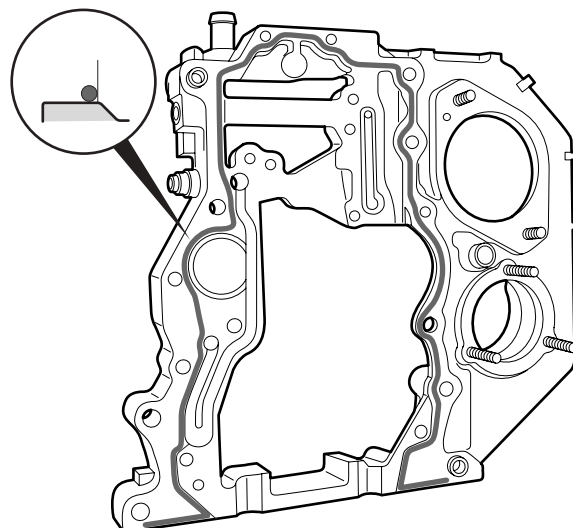

M201242

4.23 REMOVAL AND INSTALLATION, FRONT CRANKSHAFT SEAL

Removing the front crankshaft seal

1. Remove the attachment bolts of the fan and place the fan in the wind tunnel.
2. Remove the poly-V-belt.
3. Remove the attachment bolts from the vibration damper and remove the damper along with the crankshaft pulley.
4. Fit the threaded spindle (2) of the special tool (DAF no. 1453179) on the crankshaft flange.
5. Screw the push/pull piece (1) onto the spindle up to the engine panel.

Note:

Mark the drill at a length of 18 mm using a piece of tape.

6. Drill a hole through the base plate to the tape marking and fit a screw in the seal to keep the base plate in its place.
7. Drill the other five holes and fit screws.
8. Turn the threaded spindle (2) clockwise until the seal has been removed.

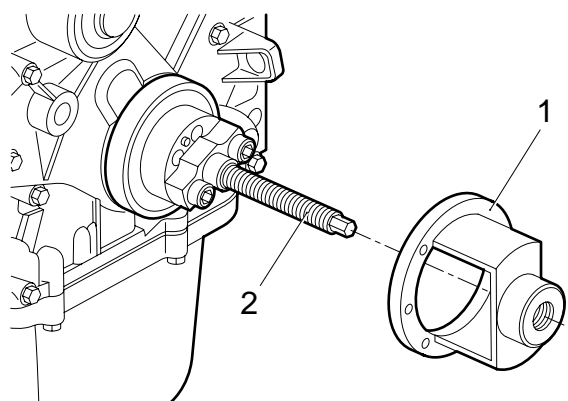

M201069

Installing the front crankshaft seal

1. Clean and inspect the seal chamber. Even minimal damage may cause a leak.
2. Fit the threaded spindle (2) of the special tool (DAF no. 1453179) on the crankshaft flange.
3. Put a new seal over the crankshaft.
4. Screw the push/pull piece (1) onto the threaded spindle (2) up to the seal.
5. Turn the threaded spindle (2) anti-clockwise until the push/pull piece (1) is level with the top panel. The seal has been properly fitted once it is level with the engine panel.
6. Remove the special tool.
7. Inspect the vibration damper.
8. Fit the crankshaft pulley and the vibration damper and tighten the attachment bolts to the specified torque. See "Technical data".
9. Fit the poly-V-belt.
10. Fit the fan.

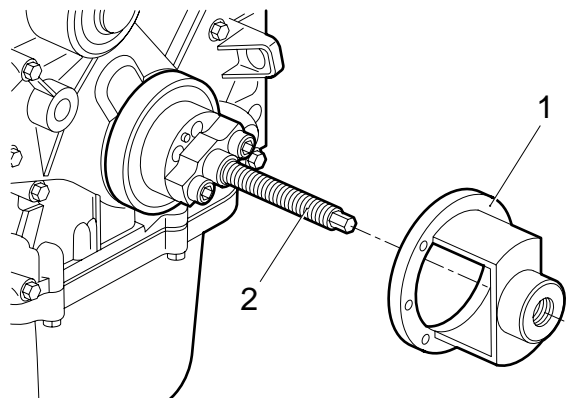

M201069

5. CLEANING

5.1 CLEANING THE ENGINE

Note:

It is advisable to clean the engine and the surrounding area with a high-pressure cleaner before starting maintenance or service operations. A clean environment makes your work easier and enables you to notice any engine defects at an early stage.

Before cleaning the engine, check for any leaks.

If the engine is cleaned with a high-pressure cleaner, this must be done with care. It is also important to observe the following points:

- when cleaning the universal joint on the steering box, the spider seals may be forced open by the high-pressure jet of water, so that the grease behind them is flushed away. As a result, the spider may get stuck, so that the steering mechanism will jam.
- there is a bleed vent on the power steering fluid reservoir of the steering gear. Water may enter the reservoir through this bleed vent, causing damage to the steering gear.
- when cleaning the radiator/intercooler element, be careful not to damage the fins.
- do not direct the high-pressure cleaner jet too long at the air-conditioning system condenser. As a result of the high temperature, the pressure in the system will become excessive, which may cause damage to the system.
- ensure that no water can enter the gearbox via the bleed vents.
- make sure that no water can enter via the clutch reservoir bleed vents.
- the engine compartment can be cleaned with a high-pressure cleaner. Never direct the jet of water towards electrical components.
- do not aim the high-pressure cleaner jet at electrical components and electrical connections such as the electronic unit, sensors, connectors and vehicle lighting through-connections, etc.
- ensure that no water can enter the air inlet system via the air inlet or its flexible seals.

CONTENTS

	Page	Date
1. SAFETY INSTRUCTIONS	1-1	200505
1.1 Safety instructions	1-1	200505
2. GENERAL	2-1	200505
2.1 System description, cooling system	2-1	200505
3. DESCRIPTION OF COMPONENTS	3-1	200505
3.1 Pressure cap	3-1	200505
3.2 Thermostat	3-2	200505
3.3 Viscous fan clutch	3-4	200505
4. CHECKING AND ADJUSTING	4-1	200505
4.1 Pressure-testing cooling system	4-1	200505
4.2 Inspecting the thermostat	4-2	200505
4.3 Inspection, viscous fan clutch	4-3	200505
5. REMOVING AND INSTALLING	5-1	200505
5.1 Removal and installation, coolant pump	5-1	200505
5.2 Removal and installation, thermostat	5-2	200505
5.3 Removal and installation, viscous fan clutch	5-3	200505
5.4 Removal and installation, radiator	5-4	200505
6. DRAINING AND FILLING	6-1	200505
6.1 Draining, filling and bleeding the cooling system	6-1	200505
7. CLEANING	7-1	200505
7.1 Cleaning the exterior of radiator and air cooler	7-1	200505
7.2 Flushing cooling system	7-3	200505

1. SAFETY INSTRUCTIONS

1.1 SAFETY INSTRUCTIONS

Fuel



Diesel fuel is an extremely flammable liquid, and must not be exposed to naked flames or come into contact with hot surfaces. The diesel fuel fumes remaining in an empty fuel tank form an extremely explosive mixture.

When fuel system components are being removed, some fuel will escape. To keep this spillage to a minimum, unscrew the tank cap to release any overpressure.

Any spilled fuel must be collected, bearing in mind the risk of fire.

Exhaust gases

Do not run the engine in an enclosed or unventilated area. Make sure exhaust fumes are properly extracted.



Exhaust gases contain carbon monoxide. Carbon monoxide is a deadly colourless and odourless gas, which, when inhaled, deprives the body of oxygen, leading to asphyxiation. Serious carbon monoxide poisoning may result in brain damage or death.

Moving parts

Remain at a safe distance from rotating and/or moving components.

Various fluids

Various oils and lubricants used on the vehicle may constitute a health hazard. This also applies to engine coolant, windscreen washer fluid, refrigerant in air-conditioning systems, battery acid and clutch fluid. So avoid inhaling and direct contact.

Electrical short-circuit

Always disconnect the battery's earth connection during repair or maintenance operations for which the electric power supply is not required.

2. GENERAL

2.1 SYSTEM DESCRIPTION, COOLING SYSTEM

The cooling system consists of a water pump, a radiator, a header tank, an oil cooler, an air compressor, a thermostat housing with one thermostat and pipes.

The water pump is located below the thermostat in the engine block.

The thermostat housing is part of the cylinder head.

From the delivery side of the water pump, the coolant is directed to the oil cooler via an opening at the back of the water pump. Afterwards the coolant flows to the cylinder block.

The coolant flows through the cylinder block, along the cylinder liners, and up to the cylinder head.

The coolant leaves the cylinder head through the thermostat housing.

Depending on the coolant temperature, the thermostat distributes the coolant flow to the radiator or back to the water pump.

The coolant transported to the radiator enters the radiator at the top and leaves it at the bottom. From the bottom of the radiator, the coolant is returned to the water pump via the return pipe.

The connection pipe to the header tank is also connected to the return pipe from the radiator. When the coolant heats up, it flows to the header tank. When the coolant cools down, it will flow back from the header tank.

The oil cooler is not only intended to cool the lubricating oil, but also to heat it in a "cold" engine.

From the cylinder block, some of the coolant flows through the air compressor.

From the air compressor, the coolant is returned to the engine block via a pipe.

The pipe which takes the coolant to the cab heater is connected to the cylinder head. From the heater, the coolant is returned to the water pump via a pipe.

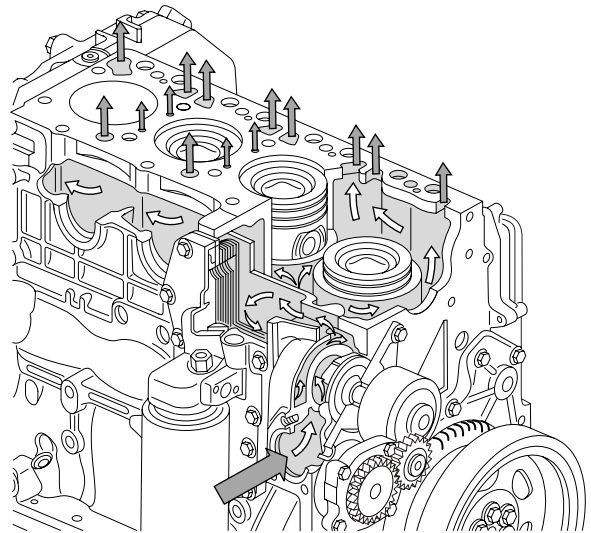

M201133

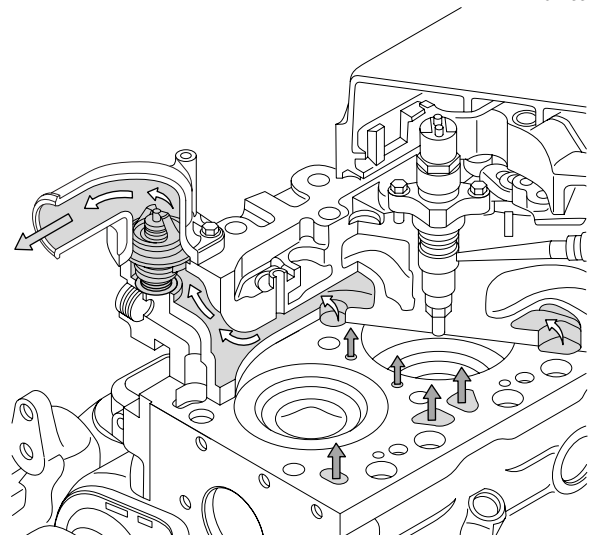

M201134

3. DESCRIPTION OF COMPONENTS

3.1 PRESSURE CAP

The pressure cap is fitted on the header tank by means of a threaded connection.

To fill the cooling system, there is a filler cap at the front of the header tank.

The pressure cap has two valves: a pressure relief valve and a vacuum relief valve. Normally, both valves are closed.

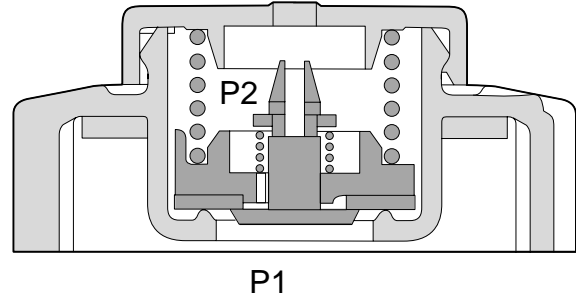

M201151

Overpressure

As a result of the rising coolant temperature, the pressure (P1) in the cooling system will increase. If the pressure in the cooling system becomes too high (0.7 bar), the pressure relief valve (1) will open against the pressure of the spring.

Negative pressure

If the coolant temperature drops, the pressure (P1) in the cooling system will decrease. If the pressure (P1) in the cooling system drops to approximately 0.1 bar below the ambient air pressure (P2), the underpressure valve will be opened.

3.2 THERMOSTAT

Operation, thermostat

Coming from the cylinder head, the coolant passes through the thermostat. Depending on the coolant temperature and the corresponding position of the thermostat, there are three possibilities:

Thermostat closed

The coolant has not yet reached the opening temperature of the thermostat (1). The supply channel (B) to the radiator is completely closed. The coolant flows directly to the water pump through a bypass (A) and the water pump returns the coolant to the cylinder block.

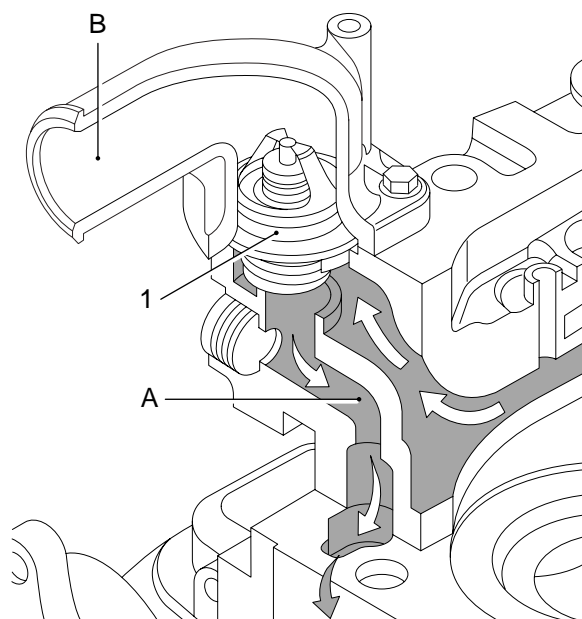

M201126

Thermostat starts opening

The coolant has reached the opening temperature of the thermostat (1). The supply channel (B) to the radiator is opened and the bypass (A) is partially closed. Now coolant will flow both through the supply channel (B) to the radiator and directly to the water pump through the bypass channel (A).

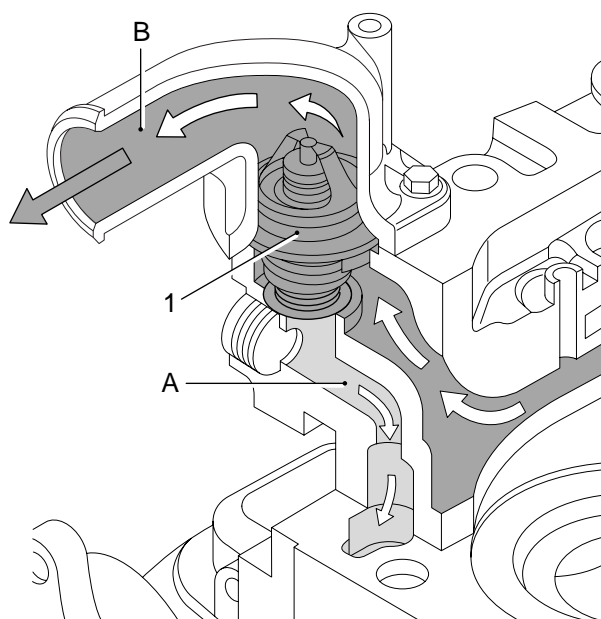

M201127

Thermostat fully opened

The temperature of the coolant has further increased. The supply channel (B) to the radiator is fully opened and the bypass (A) is fully closed. The entire coolant circulation now flows via the supply channel (B) to the radiator where it is cooled before flowing back to the water pump.

In the event of excessive coolant temperatures, removing the thermostat as an emergency solution is **not permitted**.

If the thermostat is removed from the engine, uncooled coolant will flow to the water pump through the bypass (A). As a result, the coolant temperature will continue to rise.

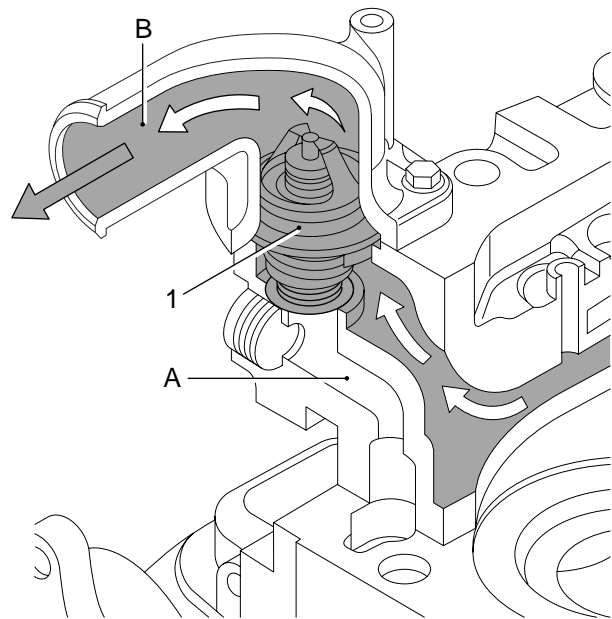

M201128

3.3 VISCOUS FAN CLUTCH

The fan is connected to the engine by means of a viscous fan clutch. If, under certain circumstances, the heat is not sufficiently dissipated by the air flow passing through the radiator, the fan will have to draw in extra cooling air through the radiator. In a viscous fan clutch, the drive torque is transmitted by a silicone fluid.

The fan clutch is divided into two chambers. In the working area (1) is the rotor (2), which is connected to the drive flange (7). The supply chamber (3) rotates freely round the drive flange (7) and is connected to the fan. There is silicone fluid in the supply chamber (3). The opening (4) in the supply chamber (3) is closed by a valve (5). The valve (5) is operated by a bimetallic strip (6).

If the opening (4) in the supply chamber (3) is closed by the valve (5), no silicone fluid can enter the working area (1). The silicone fluid still present in the working area (1) will flow back to the supply chamber (3) through the bores (8). As only very little fluid will be left in the working area (1), there will be a great difference in rotating speed (slip) between the drive flange (7) and the supply chamber (3) with the fan.

When the air temperature increases, the bimetallic strip (6) will bend and the valve (5) will partially release the opening (4) in the supply chamber (3). Through this opening, a limited amount of silicone fluid can enter the working area (1) and flow past the rotor (2). This will cause friction, so that the difference in rotating speed (slip) between the drive flange (7) and the supply chamber (3) with the fan will decrease.

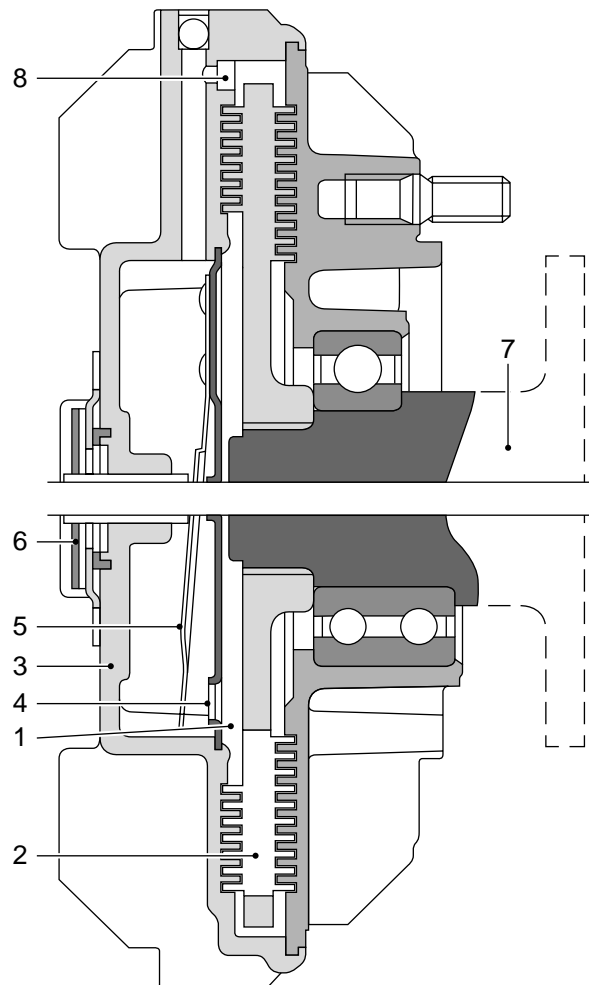

M201039

6

As the air temperature rises, the bimetallic strip (6) will continue to bend and the opening (4) in the supply chamber (3) will be fully released.

The further the opening (4) in the supply chamber (3) is released, the more silicone fluid will flow into the working area (1) and past the rotor (2). As a result of the increase in friction, the difference in rotating speed (slip) between the drive flange (7) and the supply chamber (3) will further decrease.

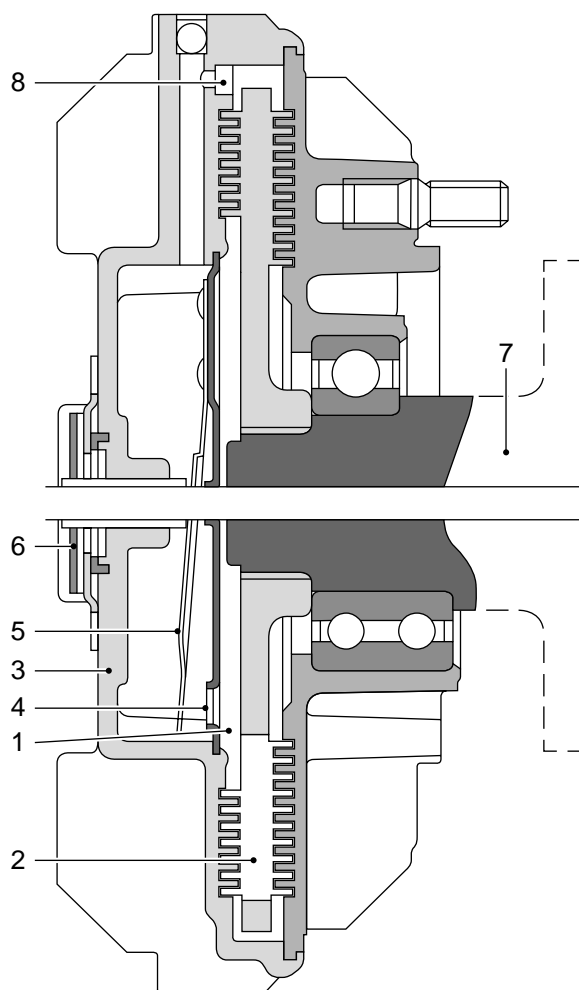

M201039

4. CHECKING AND ADJUSTING

4.1 PRESSURE-TESTING COOLING SYSTEM



When the coolant is hot, there is overpressure in the cooling system. Carefully remove the filler cap to release the overpressure. Coolant is a toxic fluid. Contact with the skin should therefore be avoided. To avoid damaging the cylinder block, do not top up a warm engine with cold coolant.

The cooling system can be checked for leaks with a pressure-test pump. If this is done when the engine is warm, any cracks can be spotted more quickly.

1. Open the grille.
2. Remove the filler cap.
3. Fill the cooling system to the correct level.
4. Raise the engine temperature. This need not be the operating temperature.

Note:

By fitting the pressure-test pump onto the filler opening of the header tank, the pressure cap can also be tested.

5. Fit a pressure-test pump. Pressure-test the system at the specified pressure. See "Technical data".
6. Check the cooling system for leakage.

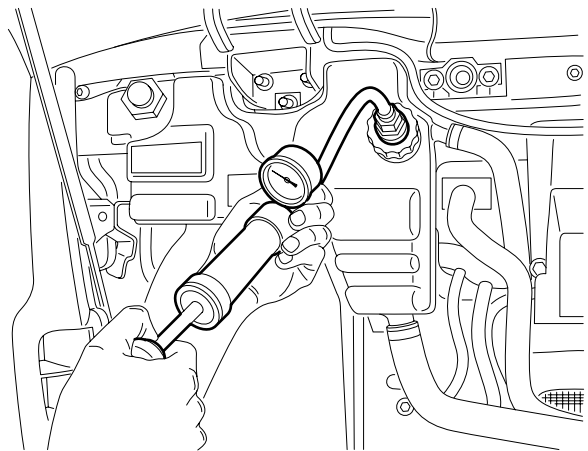

M201149

4.2 INSPECTING THE THERMOSTAT

1. Remove the thermostat. See "Removal and installation".
2. Inspect the sealing surfaces of the thermostat housing for damage.
3. Check the thermostat seat for damage.
4. Check whether the thermostat is fully closed.
5. Place the thermostat in a container filled with clean water.
6. Place a thermometer in the container and heat the water. Check at which temperature the thermostat opens and whether it opens fully. See "Technical data".

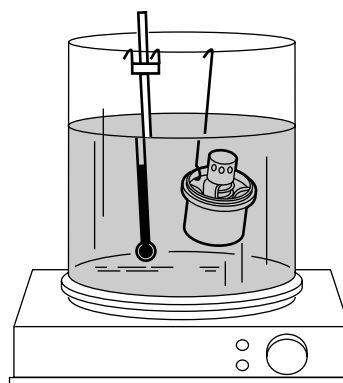

M200513

4.3 INSPECTION, VISCOUS FAN CLUTCH



Do not run the engine in an enclosed or unventilated area. Make sure exhaust fumes are properly extracted. Remain at a safe distance from rotating and/or moving components.

Testing with a cold engine

During this test, the slip in the viscous fan clutch is measured while the clutch is not operating. This test must be carried out when the engine is "cold" (coolant temperature approximately 50°C).

1. Check the coolant level, and top up as necessary.
2. Start the engine and run it at idling speed for at least 5 minutes. Then use an optical rev counter to measure the fan speed at different engine speeds (from idling to maximum engine speed). During this test procedure, the speed of the fan should be approx. 600 to 1100 rpm.

Testing with a warm engine

This test checks whether the bimetallic strip starts opening the valve at an operating temperature of 85 - 95°C.

1. Check the coolant level, and top up as necessary. Be careful when topping up the coolant of a warm engine.
2. Take a sheet of cardboard with a 100 mm hole, as shown in the drawing opposite, and place it in front of the radiator, with the hole in front of the viscous clutch.
3. Check that the gearbox is in neutral.
4. Bring the cooling system to operating temperature.
5. Allow the fan drive flange to run at a speed of 1000 rpm. Then use an optical rev counter to determine the difference between the rotating speeds of the fan and the drive flange. The speeds will differ as a result of slip in the viscous clutch. When the clutch is fully engaged, the slip must not exceed 10%. If it is more, the viscous fan clutch must be replaced.

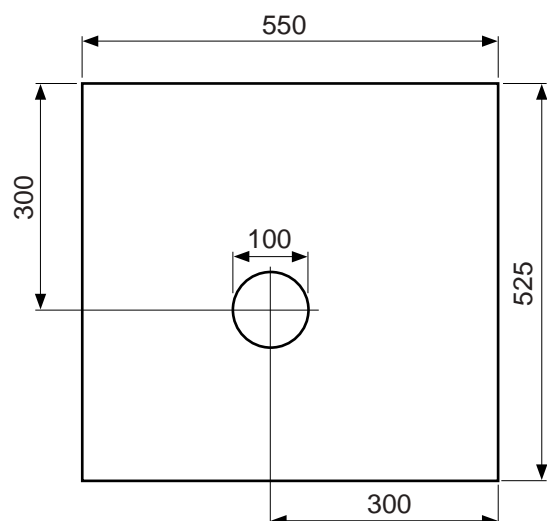

M201167

5. REMOVING AND INSTALLING

5.1 REMOVAL AND INSTALLATION, COOLANT PUMP

Removing the coolant pump

1. Drain the coolant. See "Draining and filling".
2. Remove the poly-V-belt.
3. Remove the attachment bolts from the coolant pump and remove it.

Installing the coolant pump

1. Thoroughly clean the sealing surfaces of the coolant pump and the cylinder block.
2. Fit a new O-ring to the coolant pump.
3. Install the coolant pump and tighten the attachment bolts to the specified torque. See "Technical data".
4. Fit the poly-V-belt.
5. Fill the cooling system. See "Draining and filling".

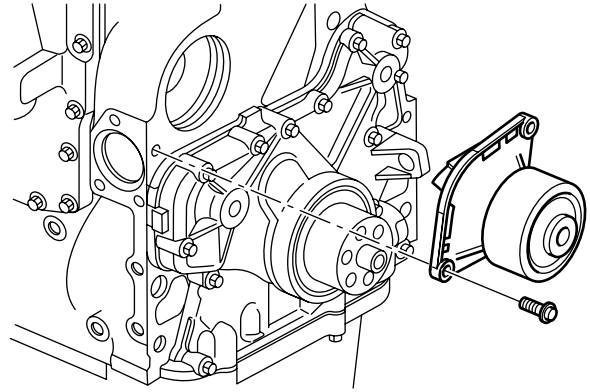

M201137

5.2 REMOVAL AND INSTALLATION, THERMOSTAT

Removing the thermostat

1. Drain the coolant. See "Draining and filling".
2. Remove the water hose between the thermostat housing and the radiator.
3. Remove the thermostat housing attachment bolts.
4. Remove the thermostat housing.
5. Remove the thermostat.

Installing the thermostat

1. Fit a new sealing ring to the thermostat.
2. Fit the thermostat in the thermostat housing.
3. Fit the thermostat housing onto the cylinder head.
4. Fit the thermostat housing attachment bolts. Tighten the attachment bolts to the specified torque. See 'Technical data'.
5. Fit the water hose between the thermostat housing and the radiator.
6. Fill the cooling system. See "Draining and filling".

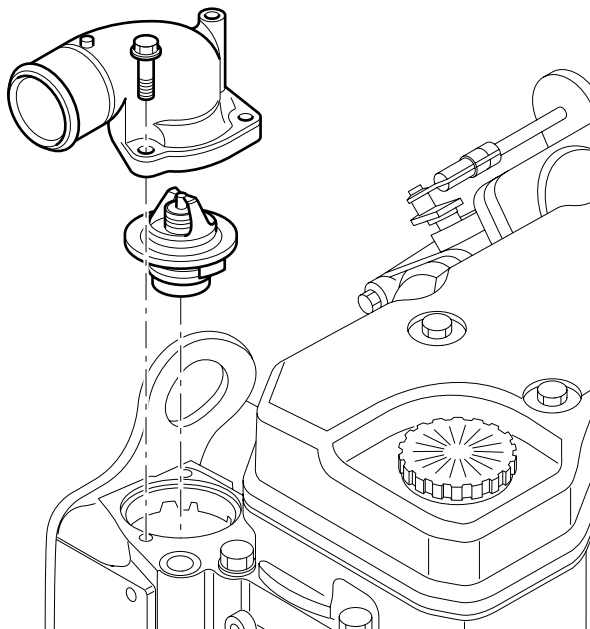

M201156

5.3 REMOVAL AND INSTALLATION, VISCOUS FAN CLUTCH

Removing the viscous fan clutch

1. Drain some of the coolant. See "Draining and filling".
2. Remove the air inlet hose with air inlet pipe between the intercooler and the inlet manifold (1).
3. Disconnect the heater hose (2) and bleed hose (3) on engine side and bend it to the front.
4. Remove the attachment nuts from the fan.
5. Remove the bolts attaching the viscous fan clutch to the drive flange. Remove the viscous fan clutch with the fan from the wind tunnel.

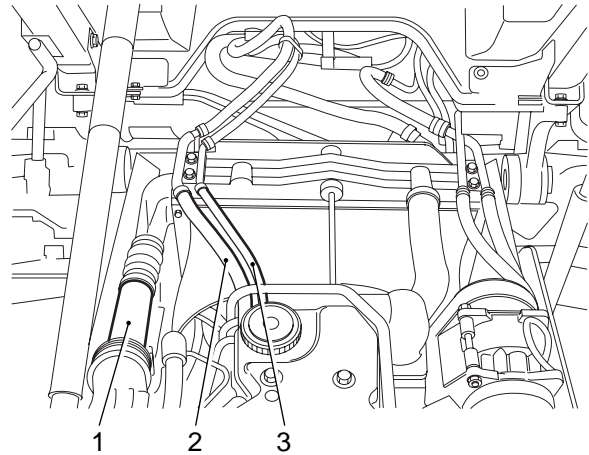

M201161

Note:

The viscous fan clutch must always be stored **vertically**.

Installing the viscous fan clutch

1. Place the new viscous fan clutch in the fan. Position it in the wind tunnel and fit the viscous fan clutch with the fan onto the drive flange.
2. Tighten the attachment nuts of the fan.
3. Fit the heater hose (2) and bleed hose (3).
4. Fit the air inlet hose with air inlet pipe between the intercooler and the inlet manifold (1).
5. Fill the cooling system. See "Draining and filling".
6. Run the engine and check that all connections are sealed properly.

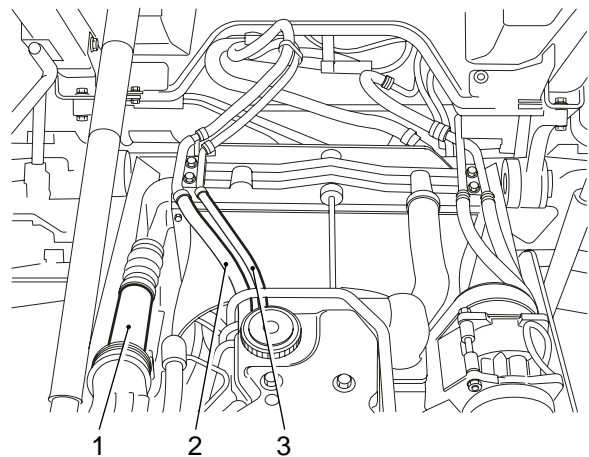

M201161

5.4 REMOVAL AND INSTALLATION, RADIATOR

Note:

The removal and installation procedure for the radiator unit allows for the presence of an air-conditioning unit.

If such a unit is not present, the relevant sections can be skipped.

Removal, radiator

1. Drain the coolant.
2. Remove the fan.
3. Remove the coolant hoses from the radiator.
4. Remove the bracket (1) of the air-conditioning pipes from the radiator.
5. Remove the left-hand air inlet hose (2) and air inlet pipe (3) from the inlet manifold to the intercooler.
6. Remove the right-hand connecting hose from the inlet pipe to the intercooler.
7. Remove the bracket (4) of the heater and bleed hoses from the radiator.
8. Remove the torque rod (5).
9. Remove the retainer clips from the condenser brackets.
10. Remove the bolts of the wind tunnel (6) and remove the wind tunnel.
11. Remove the attachment bolts from the intercooler and remove the cover plate.
12. Remove the attachment bolts from the radiator brackets. Remove the radiator and tilt the condenser slightly to free the air-conditioning pipes.

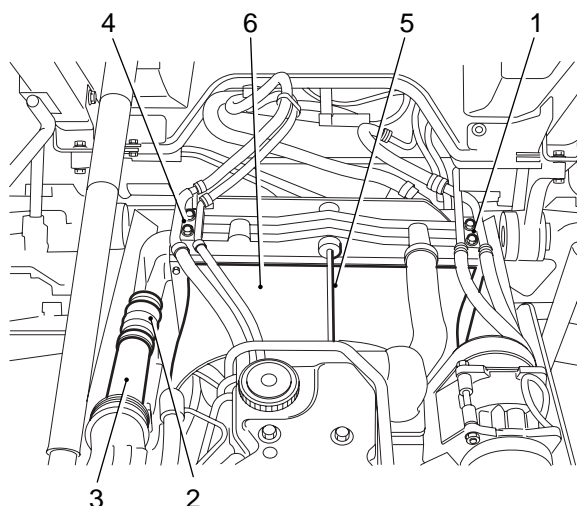

M201162

Installing the radiator

1. Fit the radiator in the chassis. Tighten the attachment nuts to the specified torque. See "Technical data".
2. Fit the intercooler onto the radiator and fit the cover plate.
3. Install the wind tunnel (6).
4. Install the torque rod (5).
5. Suspend the condenser at the bottom in the brackets and fit the retainer clips.
6. Fit the fan.
7. Fit the bracket (4) of the heater and bleed hoses on the radiator.
8. Fit the coolant hoses to the radiator
9. Fit the right-hand air inlet hose from the inlet pipe to the intercooler.
10. Fit the left-hand air inlet hose (2) and air inlet pipe (3) from the inlet manifold to the intercooler.
11. Fit the bracket (1) of the air-conditioning pipes on the radiator
12. Fill the cooling system. See "Draining and filling".
13. Run the engine and check that all connections are sealed properly.

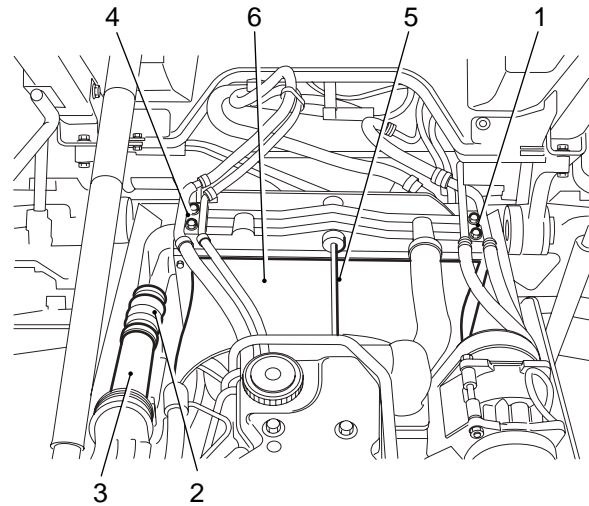

M201162

6. DRAINING AND FILLING

6.1 DRAINING, FILLING AND BLEEDING THE COOLING SYSTEM



In order to avoid damaging the engine block, do not top up a warm engine with cold coolant. Coolant is a toxic fluid and must be handled with care. Protect skin and eyes. Coolant is harmful to the environment; after use, it should be processed as industrial chemical waste. When the coolant is hot, there is overpressure in the cooling system. When removing the filler cap, allow the overpressure to escape by first loosening the filler cap one turn.

Draining the cooling system

1. Turn the heater temperature control knob in the cab to the maximum 'hot' setting.
2. Remove the cooling system filler cap.
3. Collect the coolant. Position suitable containers under the drain points.
4. Drain the cooling system at the radiator via the drain plug.
5. Flush the cooling system.
6. Close the drain plug.

Filling and bleeding the cooling system

1. Turn the heater temperature control knob in the cab to the maximum 'hot' setting.
2. Fill the cooling system with the specified coolant.
3. Run the engine for several minutes.
4. The cooling system is self-bleeding. Ensure that the bleed pipe from the thermostat housing to the header tank is not kinked or pinched.

Note:

Make sure that air can escape when the cooling system is filled.

5. Check the coolant level, and top up with coolant if necessary.

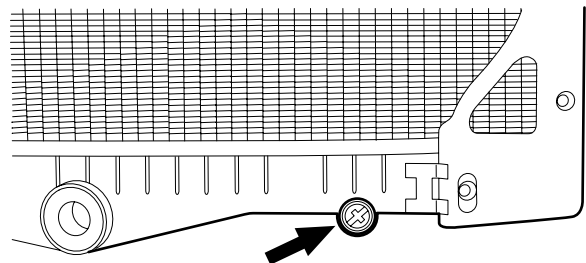

M201084

7. CLEANING

7.1 CLEANING THE EXTERIOR OF RADIATOR AND AIR COOLER



Inhalation of dust may have serious consequences for your health. Take the necessary precautions, such as wearing goggles and a facemask.

Note:

With the aid of a simple tool, the radiator and the air cooler can be blow-cleaned.

The tool (radiator cleaner) cannot be ordered from DAF. It should be manufactured by yourself according to the drawing.

Key to drawing:

- 1 Solder up
- 2 Solder
- 3 Quick-release coupling for air hose
- 4 Steel pipe, \varnothing 10 mm
- 5 6 x \varnothing 1.5 mm between holes, with a centre-to-centre distance between the holes of 7 mm, drilled on one side

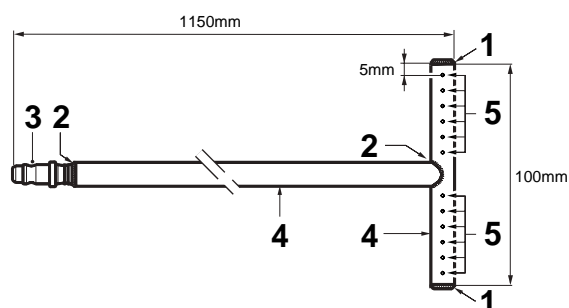

M2108

1. If the vehicle has air conditioning, loosen the support of the refrigerant pipes (1) on the radiator and remove the condenser from the air cooler supports. Push the condenser as far as possible forwards.

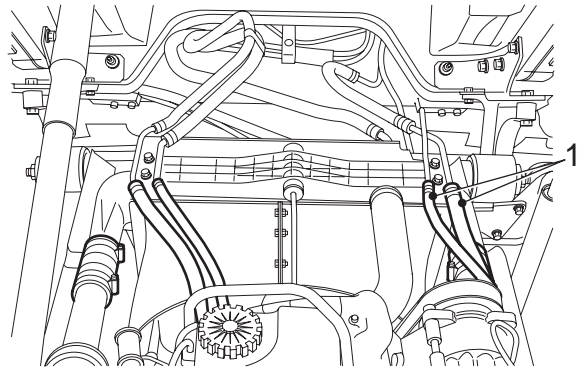

i400824

2. Insert the radiator cleaner (3) between the air cooler (1) and radiator (2) from underneath, with the air holes facing the air cooler (1).
3. Apply air pressure to the radiator cleaner (3) and continue blow-cleaning the air cooler (1) until no more dirt comes out.

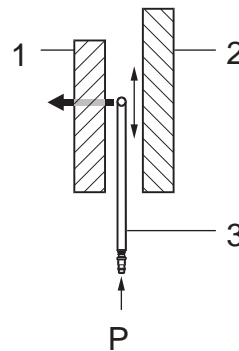

M201351

4. Turn the radiator cleaner (3) over, turning the holes towards the radiator (2), and blow-clean the radiator (2).

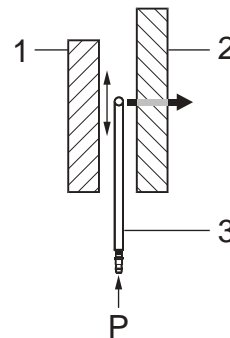

M201352

5. If the vehicle has air conditioning, fit the condenser in the air cooler supports and tighten the support of the refrigerant pipes (1) on the radiator.

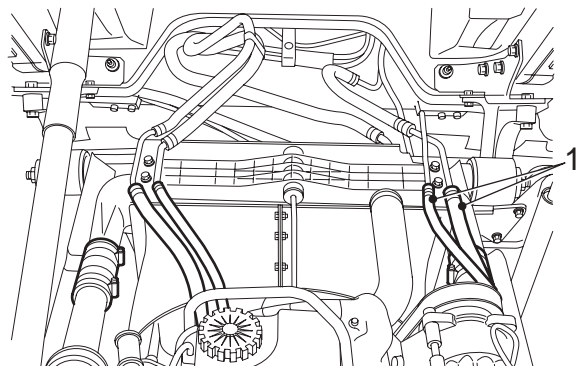

i400824

7.2 FLUSHING COOLING SYSTEM



In order to avoid damaging the engine block, do not top up a warm engine with cold coolant or other fluid.

Coolant is a toxic fluid and must be handled with care. Protect skin and eyes.

Coolant is harmful to the environment; after use, it should be processed as industrial chemical waste.

1. Drain the entire cooling system.
2. Fill the cooling system with tap water and add a cooling system cleaner. See "Technical data".
3. Leave the engine running until the thermostat is fully open.
4. Now leave the engine running for a further 45 minutes.
5. Drain the entire cooling system.
6. Fill the cooling system with tap water.
7. Leave the engine running until the thermostat is fully open.
8. Now leave the engine running for a further five minutes.
9. Drain the entire cooling system.
10. Fill the cooling system with the specified coolant.
11. Check the coolant level.

CONTENTS

	Page	Date
1. SAFETY INSTRUCTIONS	1-1	200505
1.1 Safety instructions	1-1	200505
2. GENERAL	2-1	200505
2.1 System description, lubrication system	2-1	200505
3. CHECKING AND ADJUSTING	3-1	200505
3.1 Checking engine oil consumption	3-1	200505
3.2 Inspection, lubricating oil pressure	3-2	200505
3.3 Pressure-testing the oil cooler	3-3	200505
3.4 Inspecting the lubricating oil pump	3-4	200505
4. REMOVING AND INSTALLING	4-1	200505
4.1 Removal and installation, lubricating oil filter	4-1	200505
4.2 Removal and installation, oil cooler	4-2	200505
4.3 Removal and installation, oil sump	4-3	200505
4.4 Removing and installing lubricating oil pump	4-4	200505
5. DRAINING AND FILLING	5-1	200505
5.1 Draining and replenishing engine oil	5-1	200505

1. SAFETY INSTRUCTIONS

1.1 SAFETY INSTRUCTIONS

Fuel



Diesel fuel is an extremely flammable liquid, and must not be exposed to naked flames or come into contact with hot surfaces. The diesel fuel fumes remaining in an empty fuel tank form an extremely explosive mixture.

When fuel system components are being removed, some fuel will escape. To keep this spillage to a minimum, unscrew the tank cap to release any overpressure.

Any spilled fuel must be collected, bearing in mind the risk of fire.

Exhaust gases

Do not run the engine in an enclosed or unventilated area. Make sure exhaust fumes are properly extracted.



Exhaust gases contain carbon monoxide. Carbon monoxide is a deadly colourless and odourless gas, which, when inhaled, deprives the body of oxygen, leading to asphyxiation. Serious carbon monoxide poisoning may result in brain damage or death.

Moving parts

Remain at a safe distance from rotating and/or moving components.

Various fluids

Various oils and lubricants used on the vehicle may constitute a health hazard. This also applies to engine coolant, windscreen washer fluid, refrigerant in air-conditioning systems, battery acid and clutch fluid. So avoid inhaling and direct contact.

Electrical short-circuit

Always disconnect the battery's earth connection during repair or maintenance operations for which the electric power supply is not required.

Pressure-limiting valve

A pressure limiting valve (4) is fitted in the oil cooler housing.

When the pressure set for the pressure limiting valve has been reached, the valve opens and allows the excess lubricating oil to be discharged to the supply side of the lubricating oil pump.

Oil filter

The oil is cleaned in the disposable oil filter (3). A pressure relief valve (5) fitted in the oil cooler housing opens if the pressure in the filter becomes too high as a result of contamination or cold oil. The oil then passes through the filter unfiltered.

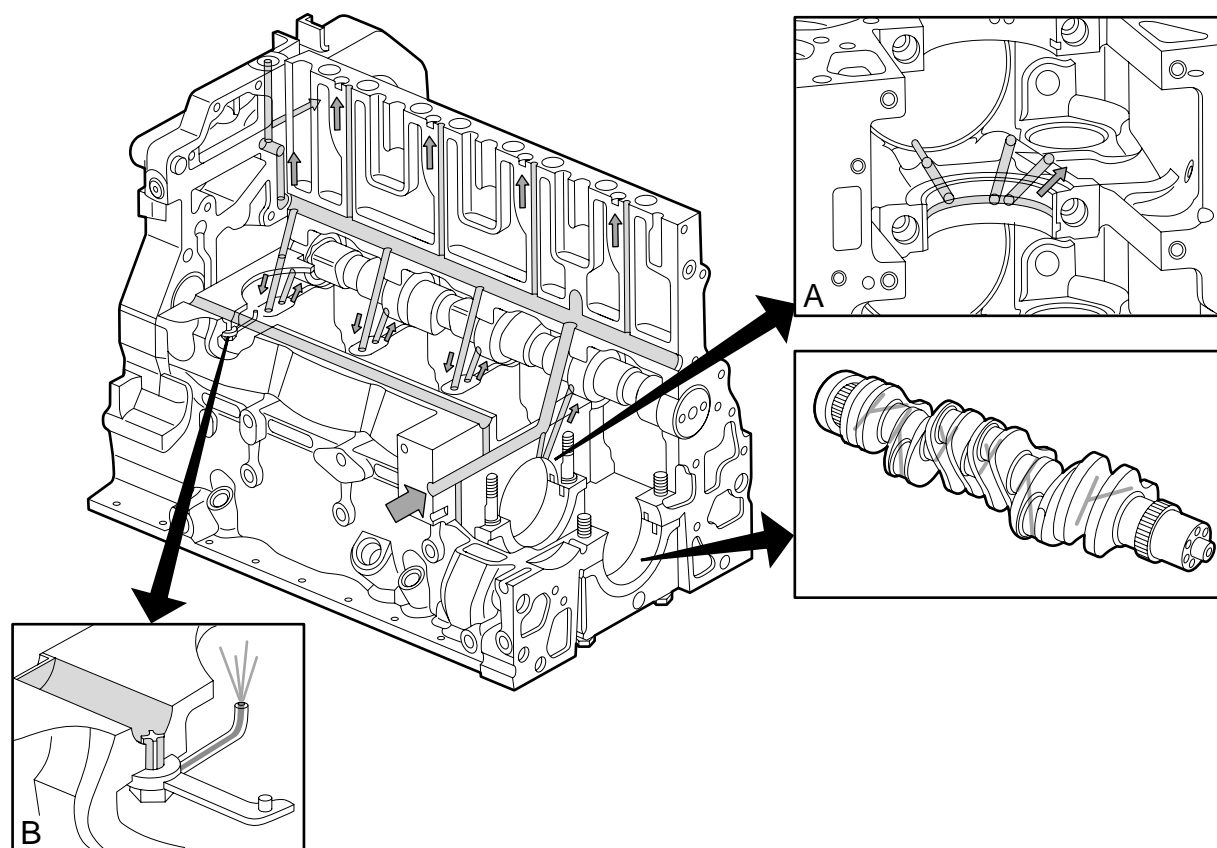

M201260

Main oil channel

From the main oil channel, lubricating oil is supplied to the crankshaft main bearings (A) and via an oil channel in the crankshaft also to the big-end bearings.

From the main oil channel, lubricating oil is pumped to the camshaft.

Cylinder head

From the main oil channel, vertical oil channels pass through the cylinder block to the cylinder head. This bore is continued in the cylinder head to supply lubricating oil to the rockers.

Piston and gudgeon pin

The pistons are lubricated by oil nozzles (B). In addition to its lubricating function, the lubricating oil has an important cooling function. A hole has been drilled at the top of the connecting rod, through which the oil that the oil nozzles spray against the piston head may reach the upper big-end bearing and the gudgeon pin.

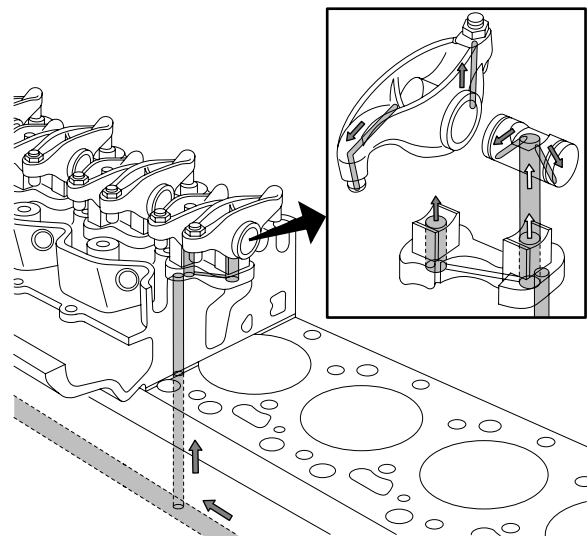

M201123

Turbocharger

The turbocharger is lubricated via an oil pipe from the oil cooler housing.

The oil discharge pipe from the turbocharger is connected to the cylinder block, from where the oil returns to the oil sump.

Air compressor

The air compressor is supplied with oil from an oil channel in the timing gear case connected to the main oil channel.

The oil returning from the air compressor flows from the front of the air compressor to the timing gear case, and from there to the oil sump.

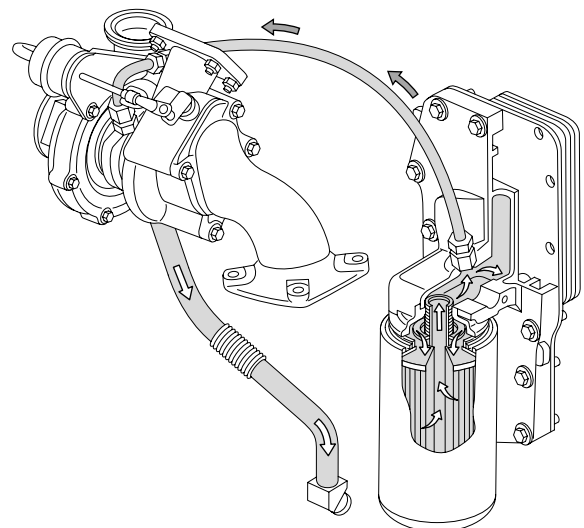

M201122

3. CHECKING AND ADJUSTING

3.1 CHECKING ENGINE OIL CONSUMPTION

Engine oil consumption relates to the engine oil used during combustion in the engine. Since engine oil consumption is affected by driving style and the use to which the vehicle is put, it is also related to average fuel consumption. See "Technical data" for the maximum permissible engine oil consumption.

Test conditions

1. An engine oil consumption test is only meaningful after the engine has been run in (approx. 25,000 km).
2. Check the engine carefully for engine oil leakage before carrying out an engine oil consumption test. First repair any leaks.
3. Check the average fuel consumption and engine oil consumption as accurately as possible.
4. Only check the engine oil level when the engine is at operating temperature and only when the engine has been turned off for five minutes.
5. Make sure the vehicle is horizontal before checking the engine oil level.

3.2 INSPECTION, LUBRICATING OIL PRESSURE

1. Bring the engine up to operating temperature.
2. Remove the plug from the main oil channel. It is located on the left, in the centre of the engine block.
3. Connect the special tool (DAF no. 0535551) to the oil pressure gauge connection.
4. Start the engine and measure the lubricating oil pressure at idling speed and at full-load engine speed. Compare the pressure readings with the technical data. See "Technical data".
5. Stop the engine and remove the oil pressure gauge. Fit a new sealing ring in the plug and insert the plug.

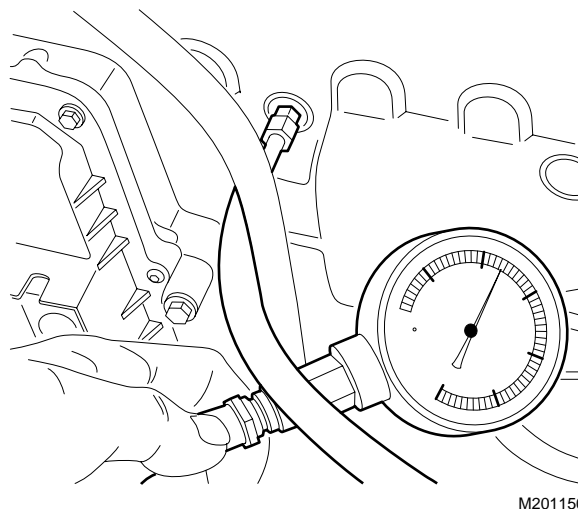

M201150

3.3 PRESSURE-TESTING THE OIL COOLER

1. Remove the oil cooler. See "Removal and installation".
2. Fit special tool (DAF no. 1329478) to the oil cooler.
3. Connect an air hose with pressure reducer valve to the special tool.
4. Immerse the oil cooler in warm water and set the specified air pressure. See "Technical data" for the specified water temperature and the test pressure.
5. Check the cooling element for leakage.

Note:

The oil cooler should be replaced if it is leaking.

6. Remove the special tool.
7. Fit the oil cooler. See "Removal and installation".

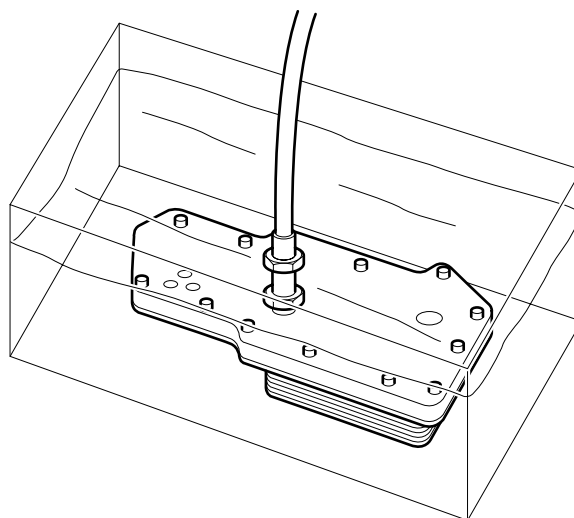

M201154

3.4 INSPECTING THE LUBRICATING OIL PUMP

Inspecting the lubricating oil pump

1. Check the lubricating oil pump drive gears for damage and excessive wear.
2. Check the drive gear backlash. See "Technical data".
3. Remove the rear plate from the lubricating oil pump.
4. Check the play between the inner and outer rotors using a feeler gauge. See "Technical data".

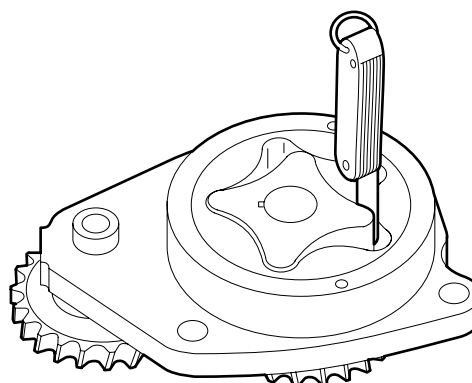

M201077

5. Check the play between the outer rotor and the pump housing using a feeler gauge. See "Technical data".

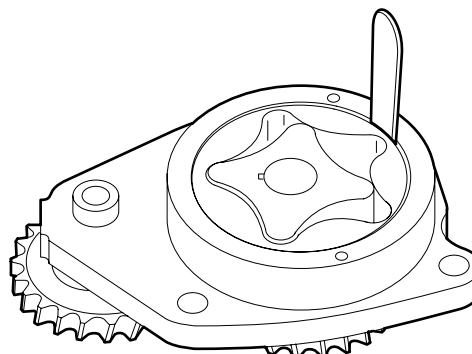

M201076

6. Using a feeler gauge and a straight edge check the play between the inner and outer rotors in relation to the pump housing. See "Technical data".
7. Mark the top of the outer rotor and remove the outer rotor.
8. Check the inner rotor and outer rotor for damage and excessive wear.
9. Fit the outer rotor with the marked side upwards.
10. Fit the rear plate.

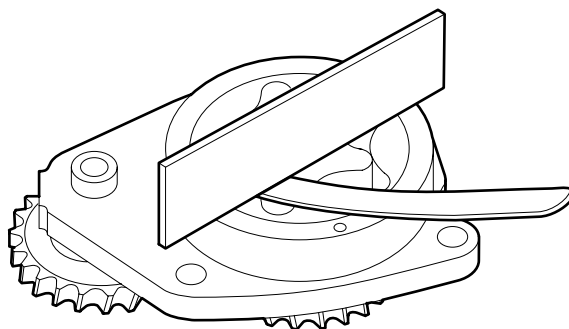

M201075

4. REMOVING AND INSTALLING

4.1 REMOVAL AND INSTALLATION, LUBRICATING OIL FILTER



To prevent skin injury, avoid unnecessary contact with the drained lubricating oil. Be careful when changing the oil. Hot oil may cause serious injuries.

Removing the oil filter

1. Clean the location and the area surrounding the filter element if extremely fouled.
2. Remove the filter element by turning it anti-clockwise. Collect any oil that is flowing out.
3. Remove the O-ring if it has not been removed already.

Installing the oil filter

1. Lightly oil the filter element sealing ring.
2. Fill the filter element with clean oil. Use the specified oil.
3. Fit the filter until the seal abuts, and tighten it by hand another $\frac{3}{4}$ to a full turn.
4. Run the engine for a short time and check whether the oil filter is correctly sealed.
5. Check the oil level and correct if necessary. Use the specified oil.

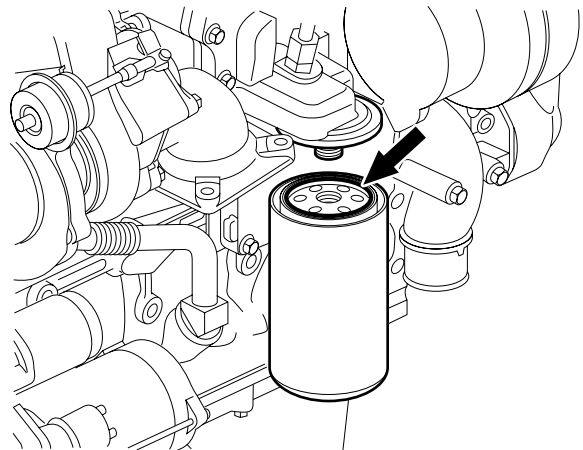

GO 00 207

4.2 REMOVAL AND INSTALLATION, OIL COOLER

Removing the oil cooler

1. Drain the coolant. See "Draining and filling".
2. Remove the lubricating oil filter.
3. Remove the turbocharger oil supply pipe.
4. Remove the attachment bolts from the oil cooler and remove the oil cooler.

Installing the oil cooler

1. Fit the oil cooler with new gaskets and tighten the attachment bolts to the specified torque and in the specified sequence. See "Technical data".
2. Tighten the oil supply pipe to the specified torque. See "Technical data".
3. Fit the lubricating oil filter.
4. Fill the cooling system.
5. Run the engine briefly, and check that the oil cooler does not leak.
6. Check the lubricating oil level.
7. Check the coolant level.

4.3 REMOVAL AND INSTALLATION, OIL SUMP

Removing the oil sump

1. Drain the engine oil. See "Draining and filling".
2. Support the oil sump.
3. Remove the attachment bolts all around.
4. Remove the oil sump (1) with sealing rubber (2) and flange (3).

Installing the oil sump

1. Thoroughly clean the sealing surfaces of the oil sump and the engine block.
2. Check the oil sump sealing rubber (2). Damaged sealing rubbers must be replaced.
3. Fit the oil sump (1) with sealing rubber (2) and flange (3) upright.
4. Fit the attachment bolts in the specified sequence and tighten them to the specified torque. See "Technical data".
5. Fill the engine with the correct amount of lubricating oil. See "Draining and Filling".
6. Run the engine for a short time and check for oil leaks. Then check the oil level.

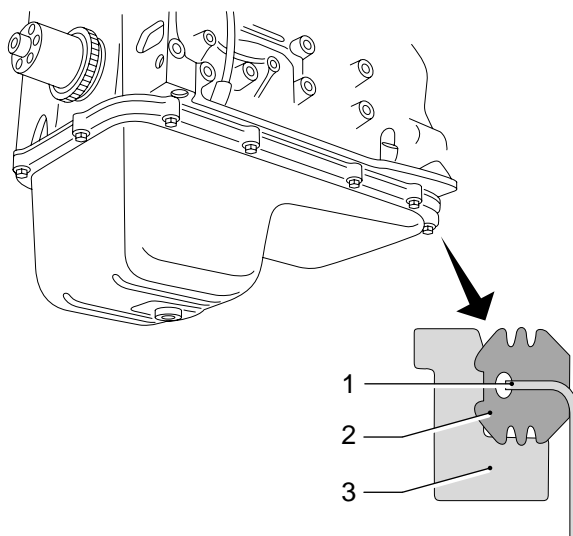

M201139

4.4 REMOVING AND INSTALLING LUBRICATING OIL PUMP

Removing lubricating oil pump

1. Remove the fan.
2. Remove the poly-V-belt.
3. Remove the vibration damper and the crankshaft pulley.
4. Remove the front crankshaft seal.
5. Remove the front engine panel.
6. Remove the attachment bolts from the lubricating oil pump crosswise and remove it.

Installing lubricating oil pump

1. Check the lubricating oil pump. See "Checking and adjusting".
2. Fill the lubricating oil pump with engine oil and position the lubricating oil pump in the cylinder block.
3. Fit the attachment bolts and tighten them crosswise to the specified torque. See "Technical data".

Note:

The rear plate of the lubricating oil pump is at the back of the bore; if the lubricating oil pump is fitted correctly, the flange will not touch the cylinder block.

4. Fit the front engine panel.
5. Fit a new front crankshaft seal.
6. Fit the crankshaft pulley and the vibration damper.
7. Fit the poly-V-belt.
8. Fit the fan.

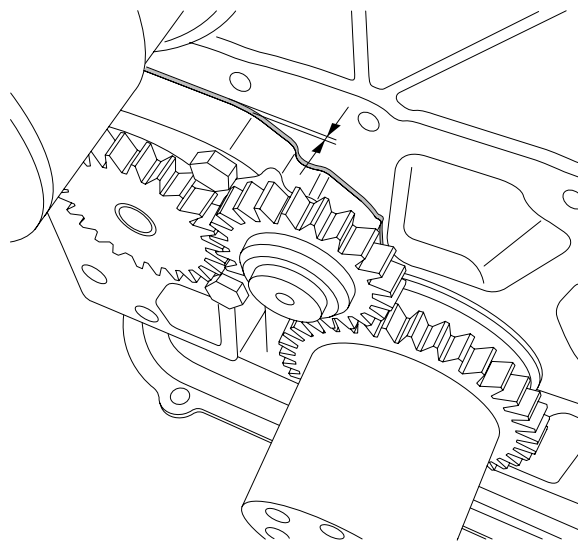

M201124

5. DRAINING AND FILLING

5.1 DRAINING AND REPLENISHING ENGINE OIL



To prevent skin injury, avoid unnecessary contact with the drained oil.

Draining engine oil

1. Ensure that the vehicle is standing on a flat and level surface.
2. Drain the engine oil at operating temperature using the drain plug in the oil sump.
3. Replace the drain plug sealing ring and tighten the drain plug to the specified torque; see "Technical data".

Replenishing engine oil

1. Fill the engine through the oil filler pipe (1) with the specified quantity of engine oil; see "Technical data".
2. Use the dipstick (2) to check the engine oil level.

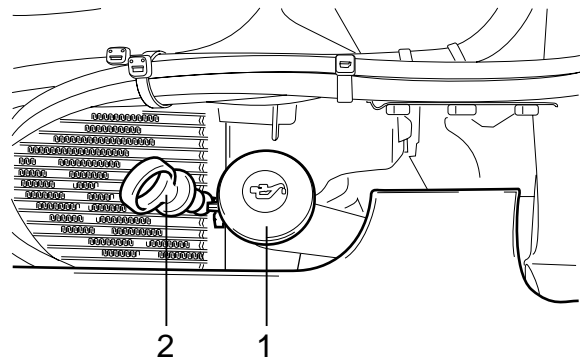

M201433

