

TECHNICAL DATA	0
DIAGNOSTICS	1
SINGLE REAR AXLE 5.10	2
SINGLE REAR AXLE 5.12	3
SINGLE REAR AXLE 5.14	4
SINGLE REAR AXLE 8.20	5
SINGLE REAR AXLE 10.20	6
SINGLE REAR AXLE 10.26	7
SINGLE REAR AXLE 11.26	8

CONTENTS

	Page	Date
1. SINGLE REAR AXLE 5.10	1-1	200313
1.1 General	1-1	200313
1.2 Tightening torques	1-1	200313
1.3 Filling capacities	1-2	200313
2. SINGLE REAR AXLE 5.12	2-1	200313
2.1 General	2-1	200313
2.2 Tightening torques	2-1	200313
2.3 Filling capacities	2-2	200313
3. SINGLE REAR AXLE 5.14	3-1	200313
3.1 General	3-1	200313
3.2 Tightening torques	3-1	200313
3.3 Filling capacities	3-2	200313
4. SINGLE REAR AXLE 8.20	4-1	200313
4.1 General	4-1	200313
4.2 Tightening torques	4-1	200313
4.3 Filling capacities	4-2	200313
5. SINGLE REAR AXLE 10.20	5-1	200313
5.1 General	5-1	200313
5.2 Tightening torques	5-1	200313
5.3 Filling capacities	5-2	200313
6. SINGLE REAR AXLE 10.26	6-1	200313
6.1 General	6-1	200313
6.2 Tightening torques	6-1	200313
6.3 Filling capacities	6-2	200313
7. SINGLE REAR AXLE 11.26	7-1	200313
7.1 General	7-1	200313
7.2 Tightening torques	7-1	200313
7.3 Filling capacities	7-2	200313

1. SINGLE REAR AXLE 5.10

1.1 GENERAL

Wheel speed sensor

Anti-corrosion agent

Molykote P37

Differential attachment stud bolts

Differential attachment stud bolt locking compound

Loctite 2701

Pinion gear splines

Sealant

Loctite 572

Differential attachment

Sealant between differential and axle housing

Loctite 518

Stub axle attachment

Sealant for stub axle flange mating surface

Loctite 518

Wheel bearing play

Wheel bearing axial play

0.05 - 0.20 mm

1.2 TIGHTENING TORQUES

The tightening torques stated in this paragraph are different from the standard tightening torques stated in the overview of the standard tightening torques. The other threaded connections which are not stated must therefore be tightened to the tightening torque stated in the overview of standard tightening torques.

When attachment bolts and nuts are to be replaced, it is important that these bolts and nuts are of exactly the same length and property class as the ones removed - unless stated otherwise -.

Differential

Attachment bolts/nuts	90 Nm ⁽¹⁾
Drain plug	54 Nm

Wheel hub

Stub axle attachment nuts	82 Nm
Wheel-speed sensor holder attachment bolts	8 Nm
Lock nut	135 Nm
Level check/filler plug	27 Nm

Notes:

1. Only use a new nut

1.3 FILLING CAPACITIES**Differential**

Filling capacity	approx. 4.0 litres
------------------	--------------------

Hub

Filling capacity	0.25 litres
------------------	-------------

2. SINGLE REAR AXLE 5.12

2.1 GENERAL

Wheel speed sensor

Anti-corrosion agent

Molykote P37

Crown wheel guide bolt

Sealant

Loctite 572

Differential attachment stud bolts

Differential attachment stud bolt locking compound

Loctite 2701

Differential attachment

Sealant between differential and axle housing

Loctite 518

Stub axle attachment

Sealant for stub axle flange mating surface

Loctite 518

Wheel bearing play

Wheel bearing axial play

0.05 - 0.20 mm

2.2 TIGHTENING TORQUES

The tightening torques stated in this paragraph are different from the standard tightening torques stated in the overview of the standard tightening torques. The other threaded connections which are not stated must therefore be tightened to the tightening torque stated in the overview of standard tightening torques.

When attachment bolts and nuts are to be replaced, it is important that these bolts and nuts are of exactly the same length and property class as the ones removed - unless stated otherwise -.

0

Differential

Attachment bolts/nuts	80 Nm ⁽¹⁾
Drive flange attachment nut (self-locking)	675 Nm ⁽²⁾
Lock nut for crown wheel guide bolt	120 Nm
Drain plug	54 Nm

Wheel hub

Stub axle attachment nuts	82 Nm
Wheel-speed sensor holder attachment bolts	8 Nm
Lock nut	135 Nm
Level check/filler plug	27 Nm

Notes:

1. Bolts to be treated with Loctite 572
2. Only use a new nut

2.3 FILLING CAPACITIES

Differential

Filling capacity	approx. 4.0 litres
------------------	--------------------

Hub

Filling capacity	0.25 litres
------------------	-------------

3. SINGLE REAR AXLE 5.14

3.1 GENERAL

Wheel speed sensor

Anti-corrosion agent

Molykote P37

Differential-gear lock stud bolts

Differential-gear lock stud bolt locking compound

Loctite 2701

Differential attachment stud bolts

Differential attachment stud bolt locking compound

Loctite 2701

Differential attachment

Sealant between differential and axle housing

Loctite 518

Stub axle attachment

Sealant for stub axle flange mating surface

Loctite 518

Wheel bearing play

Wheel bearing axial play

0.05 - 0.20 mm

3.2 TIGHTENING TORQUES

The tightening torques stated in this paragraph are different from the standard tightening torques stated in the overview of the standard tightening torques. The other threaded connections which are not stated must therefore be tightened to the tightening torque stated in the overview of standard tightening torques.

When attachment bolts and nuts are to be replaced, it is important that these bolts and nuts are of exactly the same length and property class as the ones removed - unless stated otherwise -.

0

Differential

Differential lock cover attachment bolts	20 Nm ⁽¹⁾
Attachment bolts and nuts	90 Nm ⁽¹⁾
Drive flange attachment nut (self-locking)	675 Nm ⁽²⁾
Drain plug	54 Nm

Wheel hub

Stub axle attachment nuts	82 Nm
Wheel-speed sensor holder attachment bolts	8 Nm
Lock nut	135 Nm
Level check/filler plug	27 Nm

Notes:

1. Bolts to be treated with Loctite 572
2. Only use a new nut

3.3 FILLING CAPACITIES

Differential

Filling capacity	approx. 4.0 litres
------------------	--------------------

Hub

Filling capacity	0.25 litres
------------------	-------------

4. SINGLE REAR AXLE 8.20

4.1 GENERAL

Wheel speed sensor

Anti-corrosion agent

Molykote P37

Differential-gear lock stud bolts

Differential-gear lock stud bolt locking compound

Loctite 2701

Differential attachment stud bolts

Differential attachment stud bolt locking compound

Loctite 2701

Differential attachment

Sealant between differential and axle housing

Loctite 518

Stub axle attachment

Sealant for stub axle flange mating surface

Loctite 518

Wheel bearing play

Wheel bearing axial play

0.05 - 0.20 mm

4.2 TIGHTENING TORQUES

The tightening torques stated in this paragraph are different from the standard tightening torques stated in the overview of the standard tightening torques. The other threaded connections which are not stated must therefore be tightened to the tightening torque stated in the overview of standard tightening torques.

When attachment bolts and nuts are to be replaced, it is important that these bolts and nuts are of exactly the same length and property class as the ones removed - unless stated otherwise -.

0

Differential

Drive flange attachment nut (self-locking)	675 Nm ⁽¹⁾
Differential lock cover attachment bolts	20 Nm
Attachment bolts/nuts	225 Nm ⁽²⁾
Drain plug	54 Nm

Wheel hub

Stub axle attachment nuts	82 Nm
Wheel-speed sensor holder attachment bolts	8 Nm
Lock nut	135 Nm
Level check/filler plug	27 Nm

Notes:

1. Only use a new nut
2. Bolts to be treated with Loctite 572

4.3 FILLING CAPACITIES

Differential

Filling capacity	approx. 8.0 litres
------------------	--------------------

Hub

Filling capacity	0.25 litres
------------------	-------------

5. SINGLE REAR AXLE 10.20

5.1 GENERAL

Wheel hub

Before installing the wheel hub, axle journal to be treated with

Gleitmo 805

Wheel speed sensor

Anti-corrosion agent

Molykote P37

Differential-gear lock stud bolts

Differential-gear lock stud bolt locking compound

Loctite 2701

Differential attachment stud bolts

Differential attachment stud bolt locking compound

Loctite 2701

Differential attachment

Sealant between differential and axle housing

Loctite 518

Stub axle attachment

Sealant for stub axle flange mating surface

Loctite 518

5.2 TIGHTENING TORQUES

The tightening torques stated in this paragraph are different from the standard tightening torques stated in the overview of the standard tightening torques. The other threaded connections which are not stated must therefore be tightened to the tightening torque stated in the overview of standard tightening torques.

When attachment bolts and nuts are to be replaced, it is important that these bolts and nuts are of exactly the same length and property class as the ones removed - unless stated otherwise -.

0

Differential

Drive flange attachment nut (self-locking)	675 Nm ⁽¹⁾
Differential lock cover attachment bolts	20 Nm
Attachment bolts/nuts	225 Nm ⁽²⁾
Drain plug	54 Nm

Wheel hub

- 1 st phase	300 Nm ⁽¹⁾
- 2 nd phase	turn the hub 10 revolutions at a speed of approx. 40 rpm
- 3 rd phase	350 Nm
- 4 th phase	turn the hub 10 revolutions at a speed of approx. 40 rpm
- 5 th phase	1100 Nm
Stub axle attachment bolts	260 Nm
Wheel-speed sensor holder attachment bolts	8 Nm

Notes:

1. Only use a new nut
2. Bolts to be treated with Loctite 572

5.3 FILLING CAPACITIES

Differential

Filling capacity	approx. 9.0 litres
------------------	--------------------

6. SINGLE REAR AXLE 10.26

6.1 GENERAL

Wheel hub

Before installing the wheel hub, axle journal to be treated with

Gleitmo 805

Wheel speed sensor

Anti-corrosion agent

Molykote P37

Differential-gear lock stud bolts

Differential-gear lock stud bolt locking compound

Loctite 2701

Differential attachment stud bolts

Differential attachment stud bolt locking compound

Loctite 2701

Differential attachment

Sealant between differential and axle housing

Loctite 518

Stub axle attachment

Sealant for stub axle flange mating surface

Loctite 518

6.2 TIGHTENING TORQUES

The tightening torques stated in this paragraph are different from the standard tightening torques stated in the overview of the standard tightening torques. The other threaded connections which are not stated must therefore be tightened to the tightening torque stated in the overview of standard tightening torques.

When attachment bolts and nuts are to be replaced, it is important that these bolts and nuts are of exactly the same length and property class as the ones removed - unless stated otherwise.

0

Differential

Drive flange attachment nut (self-locking)	1250 Nm ⁽¹⁾ / ⁽³⁾
Differential lock cover attachment bolts	20 Nm
Attachment bolts/nuts	225 Nm ⁽²⁾
Drain plug	54 Nm

Wheel hub

- 1 st phase	300 Nm ⁽¹⁾
- 2 nd phase	turn the hub 10 revolutions at a speed of approx. 40 rpm
- 3 rd phase	350 Nm
- 4 th phase	turn the hub 10 revolutions at a speed of approx. 40 rpm
- 5 th phase	1100 Nm
Stub axle attachment bolts	260 Nm
Wheel-speed sensor holder attachment bolts	8 Nm

Notes:

1. Only use a new nut
2. Bolts to be treated with Loctite 572
3. Secure with Loctite 262

6.3 FILLING CAPACITIES

Differential

Filling capacity	approx. 9.0 litres
------------------	--------------------

7. SINGLE REAR AXLE 11.26

7.1 GENERAL

Wheel hub unit

Before installing the wheel hub unit, axle journal to be treated with

Gleitmo 805

Wheel speed sensor

Anti-corrosion agent

Molykote P37

Differential-gear lock stud bolts

Differential-gear lock stud bolt locking compound

Loctite 2701

Differential attachment stud bolts

Differential attachment stud bolt locking compound

Loctite 2701

Differential attachment

Sealant between differential and axle housing

Loctite 518

Stub axle attachment

Sealant for stub axle flange mating surface

Loctite 518

7.2 TIGHTENING TORQUES

The tightening torques stated in this paragraph are different from the standard tightening torques stated in the overview of the standard tightening torques. The other threaded connections which are not stated must therefore be tightened to the tightening torque stated in the overview of standard tightening torques.

When attachment bolts and nuts are to be replaced, it is important that these bolts and nuts are of exactly the same length and property class as the ones removed - unless stated otherwise.

0

Differential

Drive flange attachment nut	1250 Nm ⁽¹⁾ / ⁽³⁾
Differential-gear lock attachment bolts	20 Nm
Attachment bolts/nuts	225 Nm ⁽²⁾
Drain plug	54 Nm

Wheel hub unit

- 1 st phase	500 Nm ⁽³⁾
- 2 nd phase	turn the hub 10 revolutions at a speed of approx. 40 rpm
- 3 rd phase	550 Nm
- 4 th phase	turn the hub 10 revolutions at a speed of approx. 40 rpm
- 5 th phase	1300 Nm
Stub axle attachment bolts	260 Nm

Notes:

1. Only fit a new nut and apply Loctite 262 to secure
2. Bolts to be treated with Loctite 572
3. Only use a new nut

7.3 FILLING CAPACITIES

Differential

Filling capacity	approx. 9.0 litres
------------------	--------------------

CONTENTS

	Page	Date
1. SINGLE REAR AXLE 5.10	1-1	200313
1.1 Fault-finding table	1-1	200313
2. SINGLE REAR AXLE 5.12	2-1	200313
2.1 Fault-finding table	2-1	200313
3. SINGLE REAR AXLE 5.14	3-1	200313
3.1 Fault-finding table	3-1	200313
4. SINGLE REAR AXLE 8.20	4-1	200313
4.1 Fault-finding table	4-1	200313
5. SINGLE REAR AXLE 10.20	5-1	200313
5.1 Fault-finding table	5-1	200313
6. SINGLE REAR AXLE 10.26	6-1	200313
6.1 Fault-finding table	6-1	200313
7. SINGLE REAR AXLE 11.26	7-1	200313
7.1 Fault-finding table	7-1	200313

1. SINGLE REAR AXLE 5.10**1.1 FAULT-FINDING TABLE**

COMPLAINT: NOISES IN REAR AXLE AND DRIVE ASSEMBLY	
Possible cause	Remedy
Oil level too low	Top up oil
Incorrect oil viscosity	Drain oil and top up
Attachment bolts loosened or broken off	Drain oil and check drained oil for metal particles
Pinion bearing play	Adjust and/or replace

COMPLAINT: OIL LEAK	
Possible cause	Remedy
Oil level too high	Drain oil
Incorrect oil viscosity	Drain oil and top up
Leaking oil seal	Replace oil seal
Bleeding system blocked	Clean or replace the bleeding system
Oil leakage between the differential gear housing mating surfaces	Clean mating surfaces and apply new sealant

1

2. SINGLE REAR AXLE 5.12**2.1 FAULT-FINDING TABLE**

COMPLAINT: NOISES IN REAR AXLE AND DRIVE ASSEMBLY	
Possible cause	Remedy
Oil level too low	Top up oil
Incorrect oil viscosity	Drain oil and top up
Attachment bolts loosened or broken off	Drain oil and check drained oil for metal particles
Pinion bearing play	Adjust and/or replace

COMPLAINT: OIL LEAK	
Possible cause	Remedy
Oil level too high	Drain oil
Incorrect oil viscosity	Drain oil and top up
Leaking oil seal	Replace oil seal
Bleeding system blocked	Clean or replace the bleeding system
Oil leakage between the differential gear housing mating surfaces	Clean mating surfaces and apply new sealant

1

3. SINGLE REAR AXLE 5.14

3.1 FAULT-FINDING TABLE

COMPLAINT: NOISES IN REAR AXLE AND DRIVE ASSEMBLY	
Possible cause	Remedy
Oil level too low	Top up oil
Incorrect oil viscosity	Drain oil and top up
Loosened attachment bolts or broken differential lock parts	Drain oil and check drained oil for metal particles
Pinion bearing play	Adjust and/or replace

COMPLAINT: OIL LEAK	
Possible cause	Remedy
Oil level too high	Drain oil
Incorrect oil viscosity	Drain oil and top up
Leaking oil seal	Replace oil seal
Bleeding system blocked	Clean or replace the bleeding system
Oil leakage between the differential gear housing mating surfaces	Clean mating surfaces and apply new sealant

COMPLAINT: DIFFERENTIAL LOCK IS NOT FUNCTIONING	
Possible cause	Remedy
No air pressure on engaging cylinder	Check compressed air system
Defective pneumatic control	Check or replace pneumatic switch
Defective mechanical shift control	Check shift control

COMPLAINT: DIFFERENTIAL LOCK WARNING LAMP IS NOT FUNCTIONING	
Possible cause	Remedy
Switch on cylinder fitted too high	Readjust switch
Switch on cylinder defective	Replace switch
Fault in electrical circuit	Check electrical circuit

1

4. SINGLE REAR AXLE 8.20

4.1 FAULT-FINDING TABLE

COMPLAINT: NOISES IN REAR AXLE AND DRIVE ASSEMBLY	
Possible cause	Remedy
Oil level too low	Top up oil
Incorrect oil viscosity	Drain oil and top up
Loosened attachment bolts or broken differential lock parts	Drain oil and check drained oil for metal particles
Pinion bearing play	Adjust and/or replace

COMPLAINT: OIL LEAK	
Possible cause	Remedy
Oil level too high	Drain oil
Incorrect oil viscosity	Drain oil and top up
Leaking oil seal	Replace oil seal
Bleeding system blocked	Clean or replace the bleeding system
Oil leakage between the differential gear housing mating surfaces	Clean mating surfaces and apply new sealant

COMPLAINT: DIFFERENTIAL LOCK IS NOT FUNCTIONING	
Possible cause	Remedy
No air pressure on engaging cylinder	Check compressed air system
Defective pneumatic control	Check or replace pneumatic switch
Defective mechanical shift control	Check shift control

COMPLAINT: DIFFERENTIAL LOCK WARNING LAMP IS NOT FUNCTIONING	
Possible cause	Remedy
Switch on cylinder fitted too high	Readjust switch
Switch on cylinder defective	Replace switch
Fault in electrical circuit	Check electrical circuit

5. SINGLE REAR AXLE 10.20

5.1 FAULT-FINDING TABLE

COMPLAINT: NOISES IN REAR AXLE AND DRIVE ASSEMBLY	
Possible cause	Remedy
Oil level too low	Top up oil
Incorrect oil viscosity	Drain oil and top up
Loosened attachment bolts or broken differential lock parts	Drain oil and check drained oil for metal particles
Pinion bearing play	Adjust and/or replace

COMPLAINT: OIL LEAK	
Possible cause	Remedy
Oil level too high	Drain oil
Incorrect oil viscosity	Drain oil and top up
Leaking oil seal	Replace oil seal
Bleeding system blocked	Clean or replace the bleeding system
Oil leakage between the differential gear housing mating surfaces	Clean mating surfaces and apply new sealant

COMPLAINT: DIFFERENTIAL LOCK IS NOT FUNCTIONING	
Possible cause	Remedy
No air pressure on engaging cylinder	Check compressed air system
Defective pneumatic control	Check or replace pneumatic switch
Defective mechanical shift control	Check shift control

COMPLAINT: DIFFERENTIAL LOCK WARNING LAMP IS NOT FUNCTIONING	
Possible cause	Remedy
Switch on cylinder fitted too high	Readjust switch
Switch on cylinder defective	Replace switch
Fault in electrical circuit	Check electrical circuit

1

6. SINGLE REAR AXLE 10.26

6.1 FAULT-FINDING TABLE

COMPLAINT: NOISES IN REAR AXLE AND DRIVE ASSEMBLY	
Possible cause	Remedy
Oil level too low	Top up oil
Incorrect oil viscosity	Drain oil and top up
Loosened attachment bolts or broken differential lock parts	Drain oil and check drained oil for metal particles
Pinion bearing play	Adjust and/or replace

COMPLAINT: OIL LEAK	
Possible cause	Remedy
Oil level too high	Drain oil
Incorrect oil viscosity	Drain oil and top up
Leaking oil seal	Replace oil seal
Bleeding system blocked	Clean or replace the bleeding system
Oil leakage between the differential gear housing mating surfaces	Clean mating surfaces and apply new sealant

COMPLAINT: DIFFERENTIAL LOCK IS NOT FUNCTIONING	
Possible cause	Remedy
No air pressure on engaging cylinder	Check compressed air system
Defective pneumatic control	Check or replace pneumatic switch
Defective mechanical shift control	Check shift control

COMPLAINT: DIFFERENTIAL LOCK WARNING LAMP IS NOT FUNCTIONING	
Possible cause	Remedy
Switch on cylinder fitted too high	Readjust switch
Switch on cylinder defective	Replace switch
Fault in electrical circuit	Check electrical circuit

1

7. SINGLE REAR AXLE 11.26

7.1 FAULT-FINDING TABLE

COMPLAINT: NOISES IN REAR AXLE AND DRIVE ASSEMBLY	
Possible cause	Remedy
Oil level too low	Top up oil
Incorrect oil viscosity	Drain oil and top up
Loosened attachment bolts or broken differential lock parts	Drain oil and check drained oil for metal particles
Pinion bearing play	Adjust and/or replace

COMPLAINT: OIL LEAK	
Possible cause	Remedy
Oil level too high	Drain oil
Incorrect oil viscosity	Drain oil and top up
Leaking oil seal	Replace oil seal
Bleeding system blocked	Clean or replace the bleeding system
Oil leakage between the differential gear housing mating surfaces	Clean mating surfaces and apply new sealant

COMPLAINT: DIFFERENTIAL LOCK IS NOT FUNCTIONING	
Possible cause	Remedy
No air pressure on engaging cylinder	Check compressed air system
Defective pneumatic control	Check or replace pneumatic switch
Defective mechanical shift control	Check shift control

COMPLAINT: DIFFERENTIAL LOCK WARNING LAMP IS NOT FUNCTIONING	
Possible cause	Remedy
Switch on cylinder fitted too high	Readjust switch
Switch on cylinder defective	Replace switch
Fault in electrical circuit	Check electrical circuit

1

CONTENTS

	Page	Date
1. SAFETY INSTRUCTIONS	1-1	200313
2. GENERAL	2-1	200313
2.1 Description of 5.10 axle	2-1	200313
2.2 Overview drawing, wheel hub	2-2	200313
3. INSPECTION AND ADJUSTMENT	3-1	200313
3.1 Inspecting differential oil level	3-1	200313
3.2 Inspection and adjustment, wheel bearing play	3-2	200313
3.3 Inspection, wheel-speed sensor ring	3-3	200313
4. REMOVAL AND INSTALLATION	4-1	200313
4.1 Removal and installation, stub axles	4-1	200313
4.2 Removal and installation, wheel hub	4-2	200313
4.3 Removal and installation, hub oil seal	4-4	200313
4.4 Removal and installation, wheel bearing	4-4	200313
4.5 Removal and installation, wheel-speed sensor	4-5	200313
4.6 Removal and installation, drive flange	4-6	200313
4.7 Removal and installation, pinion oil seal	4-8	200313
4.8 Removal and installation, differential	4-11	200313
5. DRAINING AND FILLING	5-1	200313
5.1 Draining and filling, differential	5-1	200313
5.2 Draining and filling, wheel hubs	5-2	200313

1. SAFETY INSTRUCTIONS



Always use stands to support the chassis or components when working under the vehicle.

Always use the appropriate lifting gear or approved hoists to remove and install heavy components. Attach the component securely to the lifting or hoisting gear.

2. GENERAL

2.1 DESCRIPTION OF 5.10 AXLE

Differential

The 5.10 axle has a differential with hypoid gearing.

A single reduction is applied.

The bevelled gear-to-pinion backlash is achieved using adjusting nuts.

The pre-load of the pinion bearings for the 5.10 axle is adjusted using a pre-load bush which is placed between the pinion and the inner race of the front bearing.

Wheel hub

The wheel hub has a wheel bearing and hub oil seal that can be replaced separately. The wheel-speed sensor ring is integrated into the wheel hub. The wheel bearing play is adjusted using the hub nut. The correct wheel bearing pre-load is achieved by fitting the hub nut as specified.

The hub nut is secured with a lock nut and a locking plate.

The wheel bearing is greased by the oil in the hub.

The stub axle and brake disc are attached to the wheel hub with attachment nuts and bolts respectively.

2.2 OVERVIEW DRAWING, WHEEL HUB

2

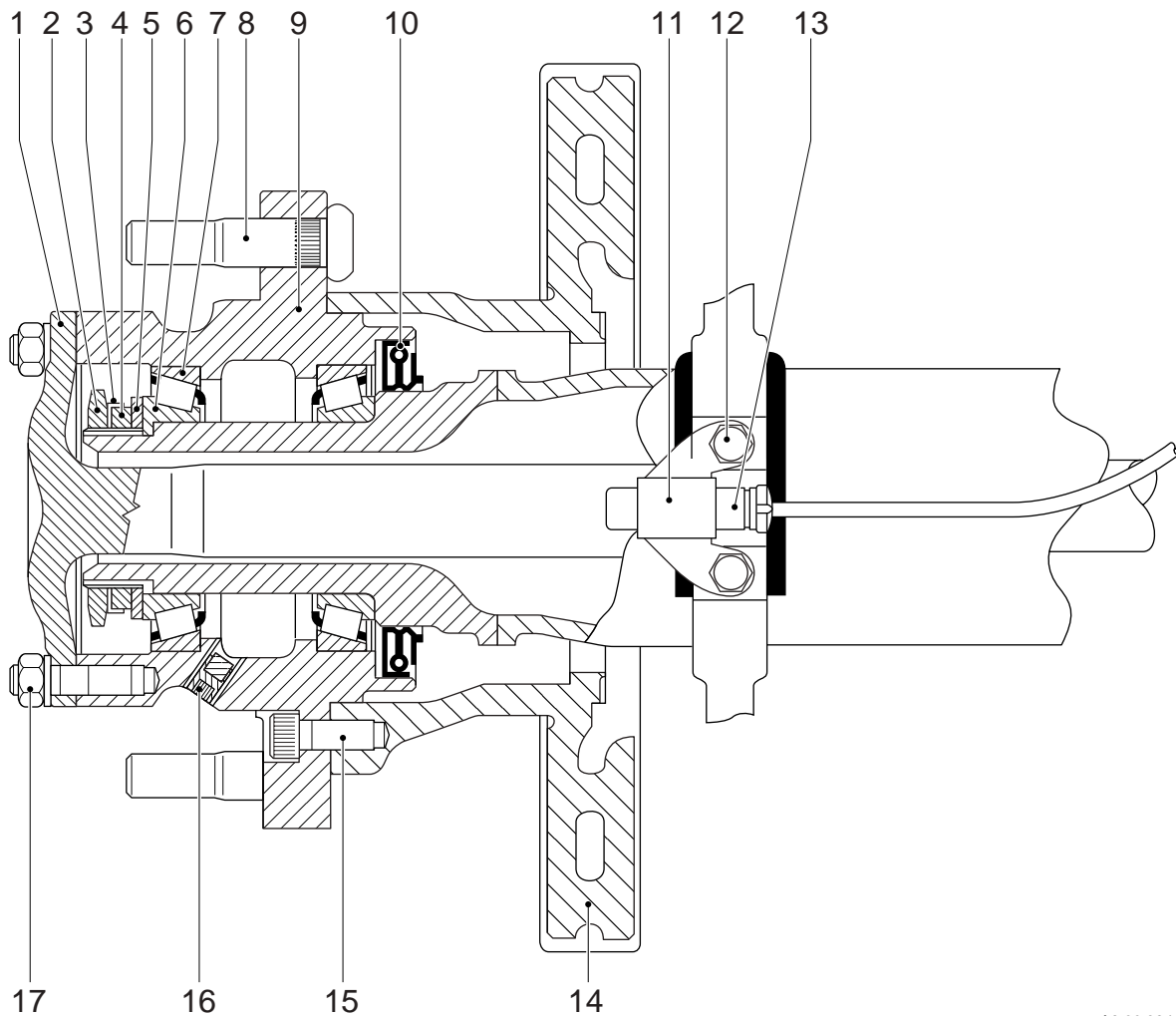

A8 00 384

Legend

- | | |
|-----------------------------|------------------------------------------------|
| 1. Stub axle | 10. Hub oil seal |
| 2. Lock nut | 11. Wheel-speed sensor holder attachment bolts |
| 3. Locking plate | 12. Wheel-speed sensor holder |
| 4. Hub nut | 13. Wheel-speed sensor |
| 5. Thrust washer | 14. Brake disc |
| 6. Wheel bearing inner race | 15. Brake disc attachment bolt |
| 7. Wheel bearing outer race | 16. Drain plug |
| 8. Wheel stud | 17. Stub axle attachment nut |
| 9. Wheel hub | |

3. INSPECTION AND ADJUSTMENT

3.1 INSPECTING DIFFERENTIAL OIL LEVEL



To prevent skin injury, avoid unnecessary contact with the drained oil.

1. Position the vehicle on a level surface.
2. Remove the level check/filler plug (1). The oil level must reach the level check/filler opening (1).
3. Apply sealant to the plug. Secure the plug.

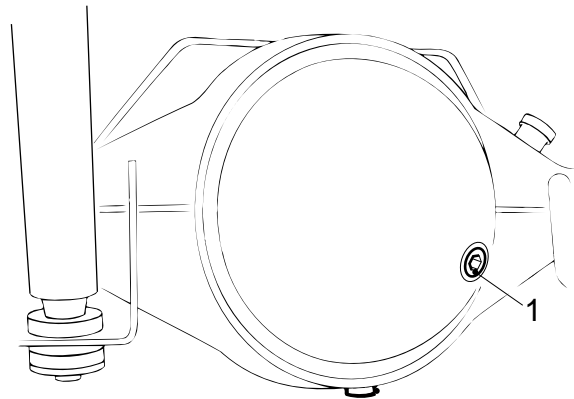

A8 00 375

3.2 INSPECTION AND ADJUSTMENT, WHEEL BEARING PLAY

Inspecting the wheel bearing play

1. Remove the wheel.
2. Remove the stub axle.
3. Remove the brake pads.
4. Fit a micrometer gauge to the wheel hub, with the stylus on the end of the axle journal.
5. Push and pull the wheel hub. Check the wheel bearing play and compare it with the specified value. See main group "Technical data".

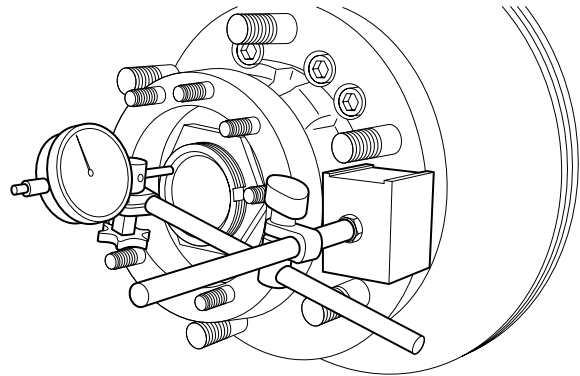

A8 00 387

Adjusting the wheel bearing play

1. Remove the lock nut.
2. Tighten the hub nut with a hub nut wrench (DAF No. 0499805) to 136 Nm.
3. Turn the hub two full rotations in order to "seat" the wheel bearings.
4. Mark (1) the hub nut wrench (2).
5. Turn the hub nut 2 strokes back.
6. Check the wheel bearing play.
7. Position the locking plate and fit the lock nut. Tighten the lock nut to the specified tightening torque. See main group "Technical data".
8. Secure the hub nut and lock nut with the locking plate.

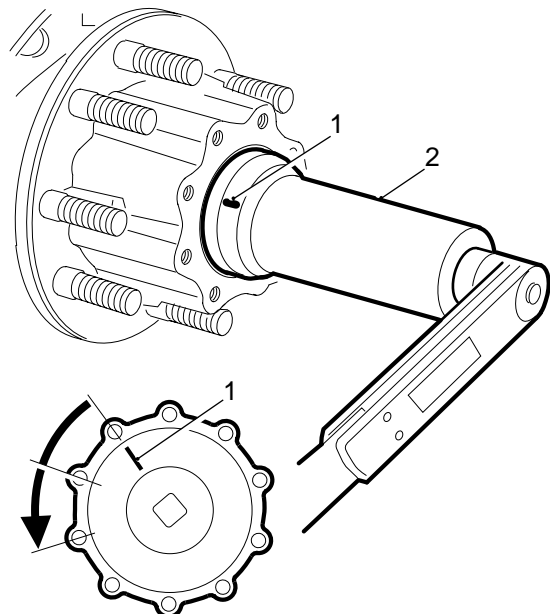

A8 00 380

3.3 INSPECTION, WHEEL-SPEED SENSOR RING

1. Check the sensor ring (2) for deposits. Special attention should be paid to deposits between the teeth of the sensor ring. Clean the sensor ring if necessary.
2. Check the sensor ring (2) for damage. Even the slightest damage may cause a failure. If necessary, replace the wheel hub.
3. Check the sensor (1) for smooth operation. If necessary, clean the sensor (1) and re-apply the specified anti-corrosion agent. See main group "Technical data".



Never tap the sensor with a hammer. This may damage both the sensor and the sensor ring.

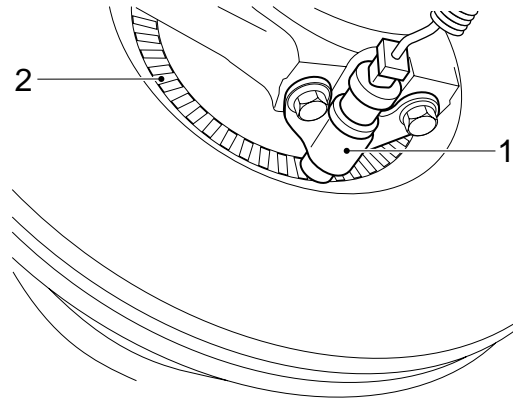

A8 00 391

4. Check the ABS system for proper operation.

4. REMOVAL AND INSTALLATION

4.1 REMOVAL AND INSTALLATION, STUB AXLES

Removing stub axles

1. Jack up the rear axle and support it on stands.
2. Remove the stub axle attachment nuts.
3. Remove the stub axle using a copper punch. When the stub axle comes loose, a small amount of oil may leak out. Collect this oil.

Installing stub axles

1. Clean the mating surfaces of the stub axle flange and wheel hub.
2. Apply the specified sealant to the mating surface of the stub axle flange. See main group "Technical data".
3. Fit the stub axle. Tighten the stub axle attachment nuts to the specified tightening torque. See main group "Technical data".

4.2 REMOVAL AND INSTALLATION, WHEEL HUB

Removing wheel hub

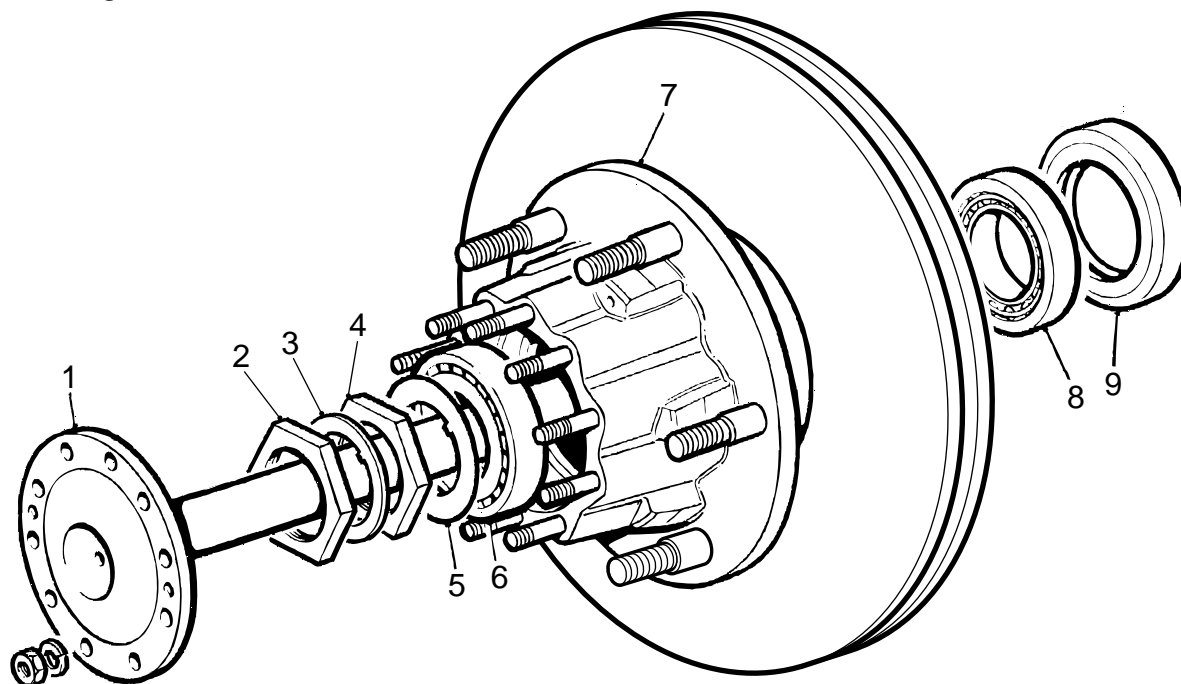

A8 00 394

1. Jack up the rear axle and support it on stands.
2. Remove the wheels.
3. Remove the brake caliper.
4. Remove the stub axle (1).
5. Remove the lock nut (2).
6. Remove the locking plate (3).
7. Remove the hub nut (4).
8. Remove the thrust washer (5).
9. Remove the wheel bearing inner race (6).
10. Remove the wheel hub from the axle journal.

Installing wheel hub

1. Check the wheel-speed sensor ring and the oil seal in the wheel hub for damage. Replace the oil seal if in doubt.
2. Check the axle journal screw thread carefully for damage.
3. Install the wheel hub on the axle journal. Slide the wheel hub onto the axle journal. Fit the wheel bearing inner race (6).
4. Fit the thrust washer (5).
5. Fit the hub nut (4).
6. Adjust the wheel bearing play, see chapter "Inspection and adjustment".
7. Fit the locking plate (3).
8. Fit the lock nut (2). Tighten the lock nut (2) to the specified tightening torque. See main group "Technical data".
9. Secure the lock nut (2) with the locking plate (3).
10. Press the wheel-speed sensor (1) against the sensor ring (2). When the vehicle is being driven, the air gap between the sensor and the sensor ring is adjusted automatically. If the sensor is stuck, remove, clean and refit it.



Never tap the sensor with a hammer. This may damage both the sensor and the sensor ring.

11. Fit the stub axle.
12. Fit the brake caliper.
13. Put the wheels back on.
14. Check the ABS system for proper operation.

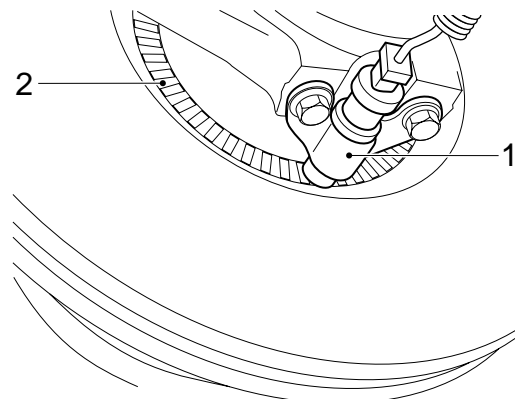

A8 00 391

4.3 REMOVAL AND INSTALLATION, HUB OIL SEAL

Removing hub oil seal

1. Remove the wheel hub from the axle journal.
2. Drill two holes into the oil seal and screw the special tool (B) (DAF No. 0484899) into the oil seal. Pull the oil seal from the pinion housing using the special tool (A) (DAF No. 0694928).

Installing hub oil seal

1. Use the special tool (DAF No. 0499809) to fit the oil seal such that the marking "outside" is pointing outward.
2. Install the wheel hub.

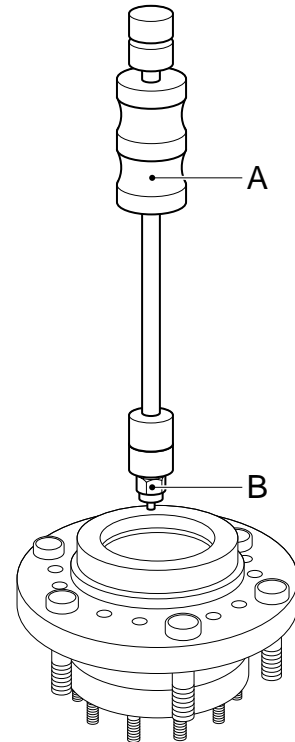

A8 00 392

4.4 REMOVAL AND INSTALLATION, WHEEL BEARING

Removing wheel bearing

1. Remove the wheel hub.
2. Remove the oil seal from the wheel hub.
3. There are recesses in the wheel hub for removing the wheel bearing outer race.
4. Remove the wheel bearing outer races from the wheel hub using a driver.

Installing wheel bearing

1. Fit the wheel bearing outer races in the wheel hub using a driver.
2. Fit the hub oil seal.
3. Install the wheel hub.

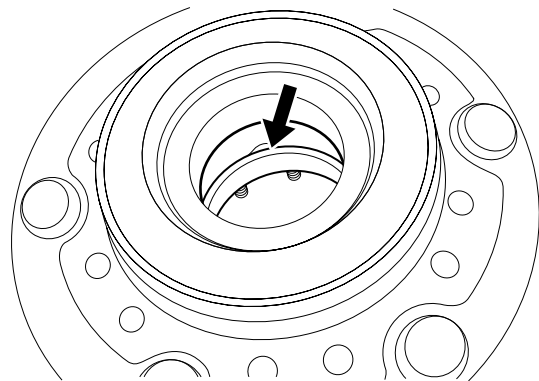

A8 00 393

4.5 REMOVAL AND INSTALLATION, WHEEL-SPEED SENSOR

Removing the wheel-speed sensor

1. Remove the wheel-speed sensor (1) from the holder (3).
2. Cut the clamping strips attaching the cable.
3. Unplug the connector and remove the wheel-speed sensor.

Installing the wheel-speed sensor

1. Clean the wheel-speed sensor (1) and the clamping sleeve (2). If necessary, replace the clamping sleeve (2).
2. Apply the specified anti-corrosion agent to the circumference of the wheel-speed sensor (1). See main group "Technical data".
3. Fit the wheel-speed sensor (1) in the holder (3). Press it against the sensor ring manually.
While the vehicle is being driven, the air gap between the sensor and the sensor ring is adjusted automatically.



Never tap the sensor with a hammer. This may damage both the sensor and the sensor ring.

4. Fit the connector and secure the cable with clamping strips.
5. Check the ABS system for proper operation.

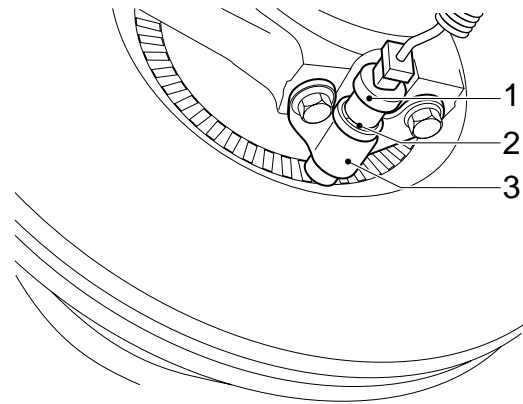

A8 00 435

4.6 REMOVAL AND INSTALLATION, DRIVE FLANGE

Removing drive flange

1. Remove the prop shaft from the drive flange.
2. Jack up the rear axle and support it on stands.
3. Remove the stub axles.
4. Determine the pre-load of the pinion bearings by turning the drive flange nut using a torque wrench with a dial (2) and a 12-sided socket (1). Write down the measured slip torque.

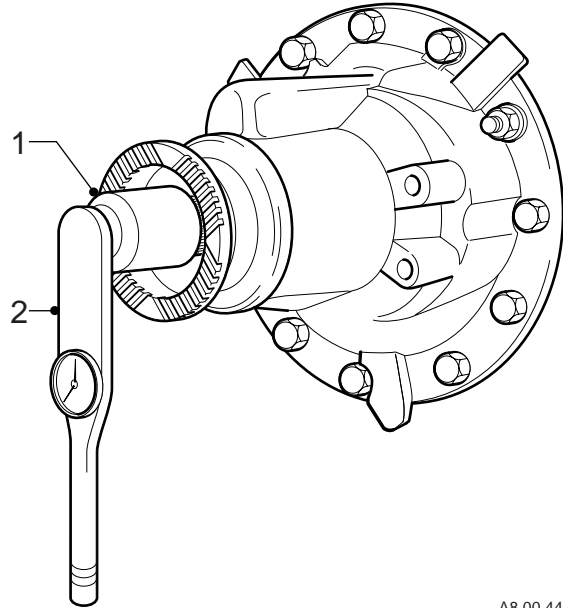

A8 00 442

5. Fit the special tool (B) (DAF No. 0484977) on the drive flange to prevent it from turning. Remove the drive flange nut using a 12-sided socket and a torque amplifier (A).
6. Remove the drive flange. If necessary, use a puller.

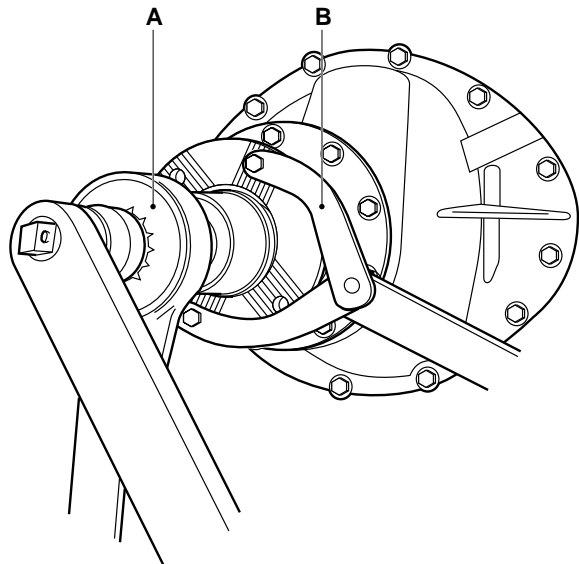

A8 00 386

Installing drive flange

1. Check the dust seal ring of the drive flange. If required, replace the dust seal ring.
2. Check the drive flange at the oil-seal running surface for grooves and/or sharp edges. If required, replace the drive flange.
3. Clean the splines of the pinion and drive flange.

4. Apply the specified sealant to the splines of the pinion. See main group "Technical data".
5. Fit the drive flange.
6. Fit a new drive flange nut.
7. Fit the special tool (3) (DAF No. 0484977) to the drive flange to prevent it from turning. Tighten the drive flange nut using a 12-sided socket and a torque amplifier (A) until no play is noticeable on the pinion.
8. Turn the drive flange a number of times to "seat" the pinion bearings.
9. Tighten the drive flange until the slip torque of the drive flange nut exceeds the noted value by 0.4 - 0.6 Nm.

Note:

If the slip torque of the drive flange nut exceeds the noted value increased by 0.4 - 0.6 Nm, loosen the drive flange nut a few strokes and repeat the setting procedure.

10. Fit the stub axles.
11. Fit the prop shaft to the drive flange.

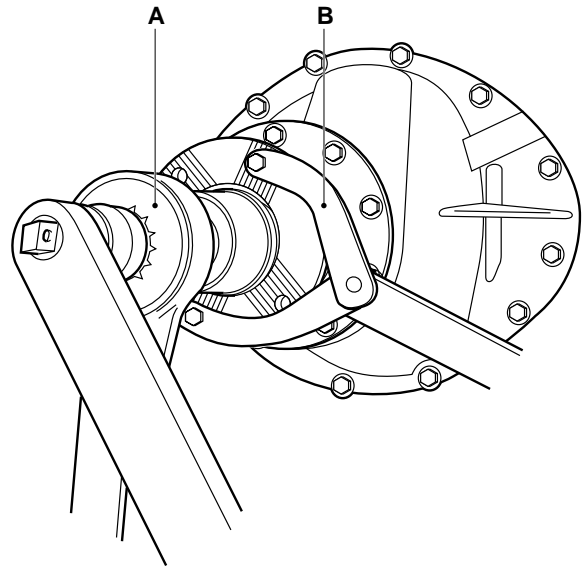

A8 00 386

4.7 REMOVAL AND INSTALLATION, PINION OIL SEAL

Removing pinion oil seal

1. Remove the prop shaft from the drive flange.
2. Jack up the rear axle and support it on stands.
3. Remove the stub axles.
4. Determine the pre-load of the pinion bearings by turning the drive flange nut using a torque wrench with a dial (2) and a 12-sided socket (1). Write down the measured slip torque.

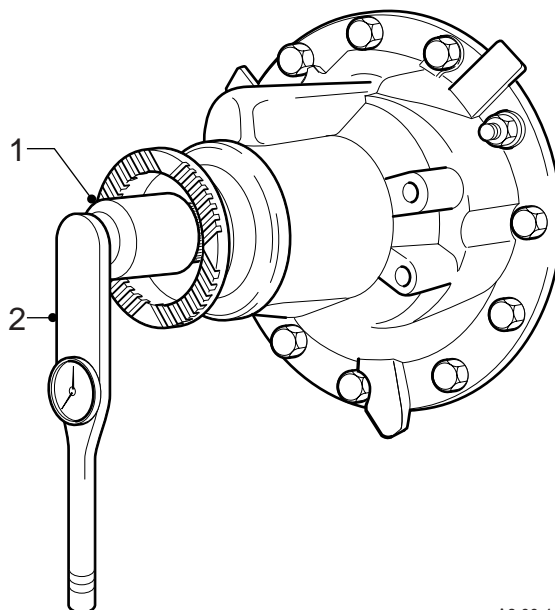

A8 00 442

5. Fit the special tool (B) (DAF No. 0484977) on the drive flange to prevent it from turning. Remove the drive flange nut using a 12-sided socket and a torque amplifier (A).
6. Remove the drive flange. If necessary, use a puller.

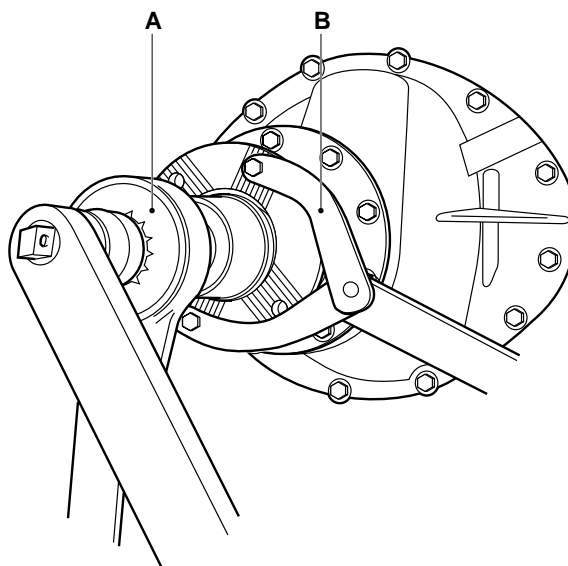

A8 00 386

7. Remove the oil seal (1) from the differential housing.

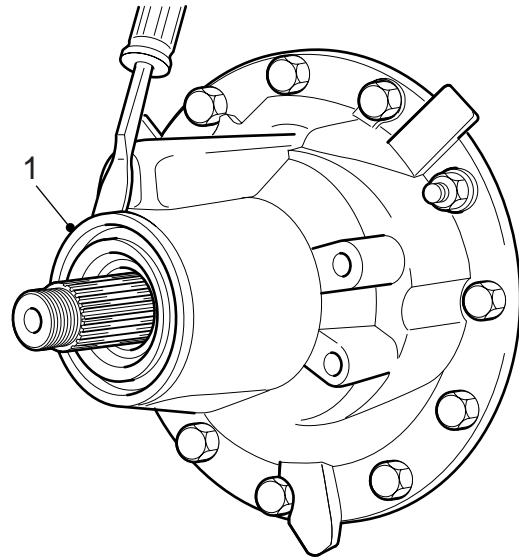

A8 00 441

2

Installing pinion oil seal

1. Use the special tool (DAF No. 1453141) to fit the oil seal. Make sure that the steel outer ring of the oil seal abuts fully against the differential housing.
2. Check the dust seal ring of the drive flange. If required, replace the dust seal ring.
3. Check the drive flange at the oil seal running surface for grooves and/or sharp edges. If required, replace the drive flange.
4. Clean the splines of the pinion and drive flange.
5. Apply the specified sealant to the splines of the pinion. See main group "Technical data".
6. Fit the drive flange.
7. Fit a new drive flange nut.

8. Fit the special tool (B) (DAF No. 0484977) on the drive flange to prevent it from turning. Tighten the drive flange nut using a 12-sided socket and a torque amplifier (A) until no play is noticeable on the pinion.
9. Turn the drive flange a number of times to "seat" the pinion bearings.
10. Tighten the drive flange until the slip torque of the drive flange nut exceeds the noted value by 0.4 - 0.6 Nm.

Note:

If the slip torque of the drive flange nut exceeds the noted value increased by 0.4 - 0.6 Nm, loosen the drive flange nut a few strokes and repeat the setting procedure.

11. Fit the stub axles.
12. Fit the prop shaft to the drive flange.

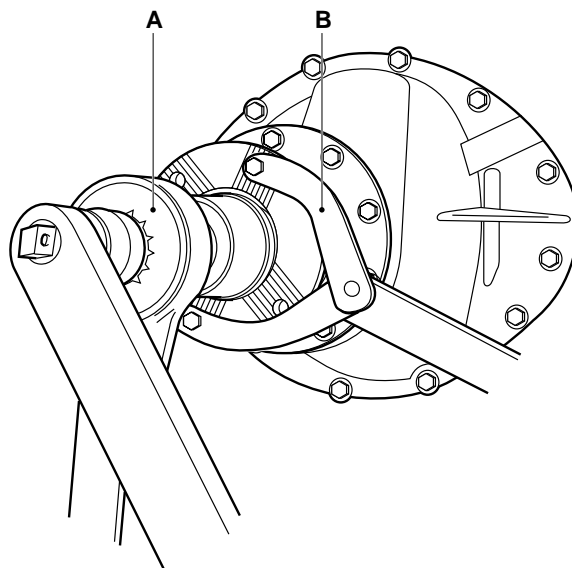

A8 00 386

4.8 REMOVAL AND INSTALLATION, DIFFERENTIAL

Removing differential

1. Drain the oil from the differential. See chapter "Draining and filling".
2. Remove the prop shaft from the drive flange.
3. Remove the stub axles.
4. Attach the differential securely to a lifting device.
5. Remove the attachment bolts and nuts from the differential.
6. Remove the differential from the axle housing by carefully pressing the differential off the axle housing using a pry bar at the indicated places.

Installing differential

1. Clean the mating surfaces of the axle housing and the differential housing. Regrind the mating faces lightly. Do not damage the mating faces in the process.
2. Clean and degrease the bolts. Check the bolts and stud bolts for signs of damage.
3. Apply a thin, even layer of sealant to the mating surface and around the bolt holes of the axle housing.
4. Apply locking compound to the attachment bolts. See main group "Technical data".
5. Fit the differential into the axle housing. Fit the attachment bolts and nuts and tighten them evenly. Tighten the attachment bolts and nuts to the specified tightening torque. See "Technical data".
6. Fit the stub axles.
7. Fit the prop shaft to the drive flange.
8. Fill the differential with oil. See chapter "Draining and filling".

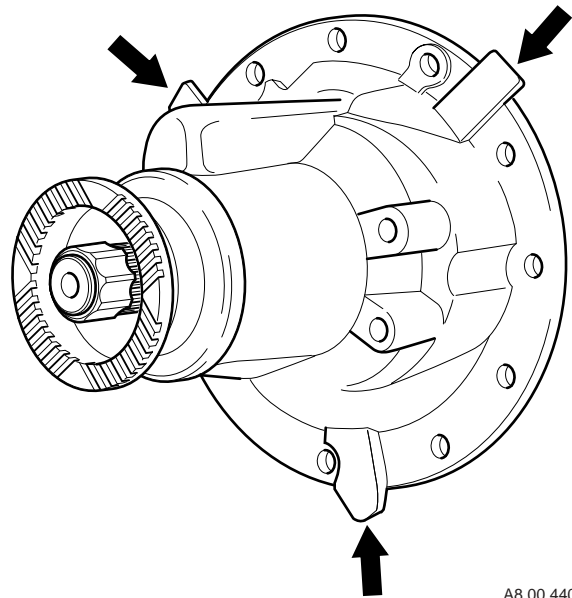

A8 00 440

5. DRAINING AND FILLING

5.1 DRAINING AND FILLING, DIFFERENTIAL



To prevent skin injury, avoid unnecessary contact with the drained oil.

Draining the differential

1. Position the vehicle on a level surface.
2. Place a suitable tray beneath the differential to collect the oil.
3. Remove the drain plug (1) and the level check/filler plug (2). Drain the oil.
4. Apply sealant to the screw thread of the drain plug (1). Install the drain plug (1) and tighten it to the specified tightening torque. See main group "Technical data".

Filling the differential

1. Fill the differential via the level check/filler plug (2) with the specified and correct quantity of oil. See main group "Technical data".
2. Check the oil level after 5 minutes; it should reach up to the level check/filler plug (2).
3. Apply sealant to the screw thread of the level check/filler plug (2). Fit the level check/filler plug (2).

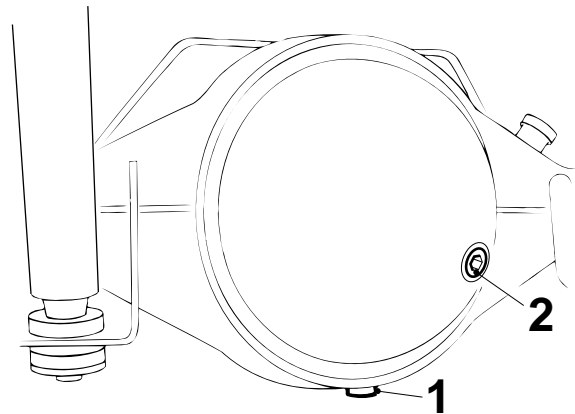

A8 00 370

5.2 DRAINING AND FILLING, WHEEL HUBS



To prevent skin injury, avoid unnecessary contact with the drained oil.

Note:

The design of the hub and the location of the drain/filler plug may differ from the illustration, depending on the version.

Draining wheel hub

1. Position the vehicle on a level surface.
2. Position the wheels in such a way that the oil drain/filler plug (1) is at the bottom.
3. Place a suitable tray under the hub to collect the oil. Remove the oil drain/filler plug (1).
4. Drain the oil and let the oil leak out of the hub.

Filling wheel hub

1. Position the wheels in such a way that the oil drain/filler plug (1) is at the top.
2. Fill the wheel hub with the specified and correct quantity of oil. See main group "Technical data".
3. Apply sealant to the screw thread of the oil drain/filler plug (1). Fit the oil drain/filler plug (1) into the hub.

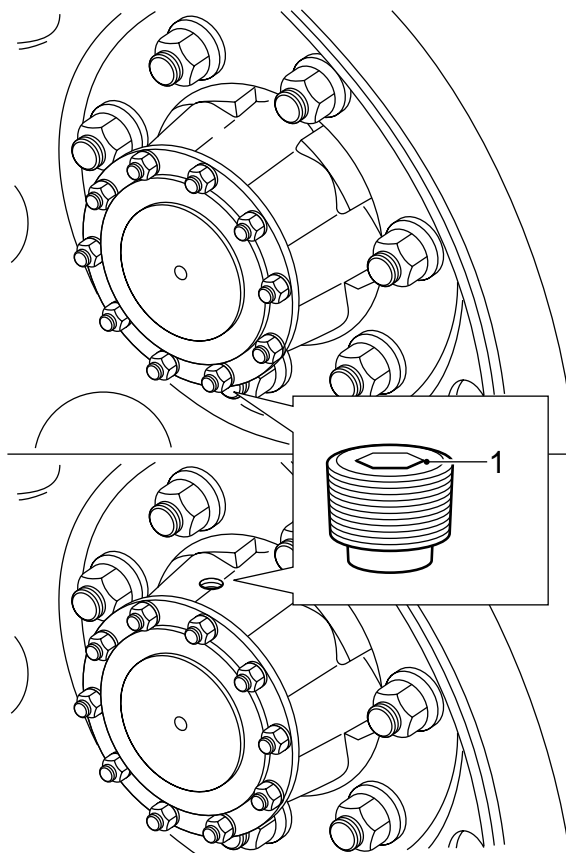

A8 00 369

CONTENTS

	Page	Date
1. SAFETY INSTRUCTIONS	1-1	200313
2. GENERAL	2-1	200313
2.1 Description of 5.12 axle	2-1	200313
2.2 Overview drawing, wheel hub	2-2	200313
3. INSPECTION AND ADJUSTMENT	3-1	200313
3.1 Inspecting differential oil level	3-1	200313
3.2 Adjusting the crown wheel guide bolt	3-2	200313
3.3 Inspection and adjustment, wheel bearing play	3-3	200313
3.4 Inspection, wheel-speed sensor ring	3-4	200313
4. REMOVAL AND INSTALLATION	4-1	200313
4.1 Removal and installation, stub axles	4-1	200313
4.2 Removal and installation, wheel hub	4-2	200313
4.3 Removal and installation, hub oil seal	4-4	200313
4.4 Removal and installation, wheel bearing	4-4	200313
4.5 Removal and installation, wheel-speed sensor	4-5	200313
4.6 Removal and installation, drive flange	4-6	200313
4.7 Removal and installation, pinion oil seal	4-7	200313
4.8 Removal and installation, differential	4-8	200313
5. DRAINING AND FILLING	5-1	200313
5.1 Draining and filling, differential	5-1	200313
5.2 Draining and filling, wheel hubs	5-2	200313

1. SAFETY INSTRUCTIONS



Always use stands to support the chassis or components when working under the vehicle.

Always use the appropriate lifting gear or approved hoists to remove and install heavy components. Attach the component securely to the lifting or hoisting gear.

2. GENERAL

2.1 DESCRIPTION OF 5.12 AXLE

Differential

The 5.12 axle has a differential with hypoid gearing.

A single reduction is applied.

The bevelled gear-to-pinion backlash is achieved using adjusting nuts.

The pre-load of the pinion bearings for the 5.12 axle is adjusted using shims which are placed between the bearing inner races.

The pinion housing of the 5.12 axle can be removed using jacking bolts.

Wheel hub

The wheel hub has a wheel bearing and hub oil seal that can be replaced separately. The wheel-speed sensor ring is integrated into the wheel hub. The wheel bearing play is adjusted using the hub nut. The correct wheel bearing pre-load is achieved by fitting the hub nut as specified.

The hub nut is secured with a lock nut and a locking plate.

The wheel bearing is greased by the oil in the hub.

The stub axle and brake disc are attached to the wheel hub with attachment nuts and bolts respectively.

2.2 OVERVIEW DRAWING, WHEEL HUB

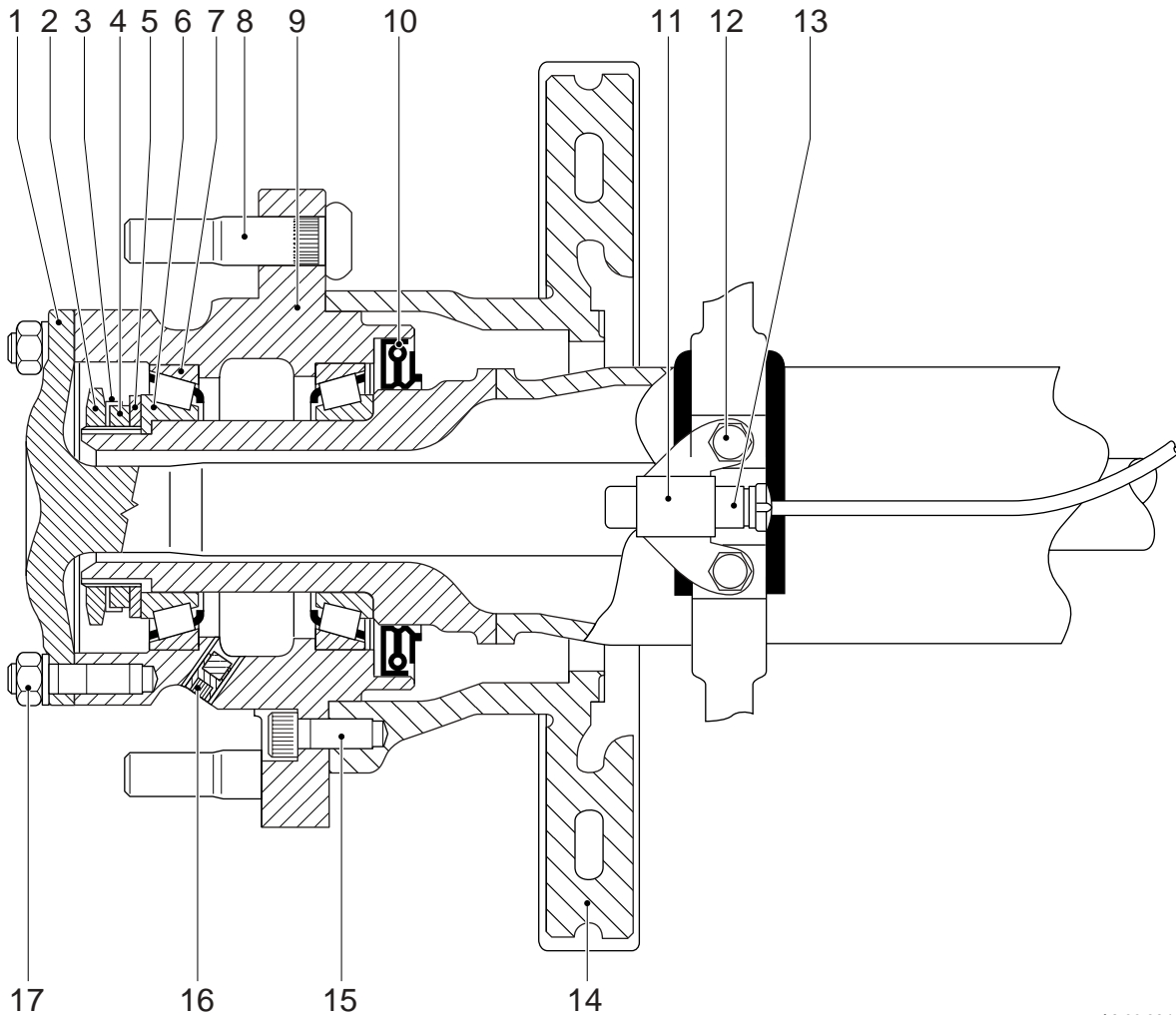

A8 00 384

Legend

- | | |
|-----------------------------|------------------------------------------------|
| 1. Stub axle | 10. Hub oil seal |
| 2. Lock nut | 11. Wheel-speed sensor holder |
| 3. Locking plate | 12. Wheel-speed sensor holder attachment bolts |
| 4. Hub nut | 13. Wheel-speed sensor |
| 5. Thrust washer | 14. Brake disc |
| 6. Wheel bearing inner race | 15. Brake disc attachment bolt |
| 7. Wheel bearing outer race | 16. Drain plug |
| 8. Wheel stud | 17. Stub axle attachment nut |
| 9. Wheel hub | |

3

3. INSPECTION AND ADJUSTMENT

3.1 INSPECTING DIFFERENTIAL OIL LEVEL



To prevent skin injury, avoid unnecessary contact with the drained oil.

1. Position the vehicle on a level surface.
2. Remove the level check/filler plug (1). The oil level must reach the level check/filler opening (1).
3. Apply sealant to the plug. Secure the plug.

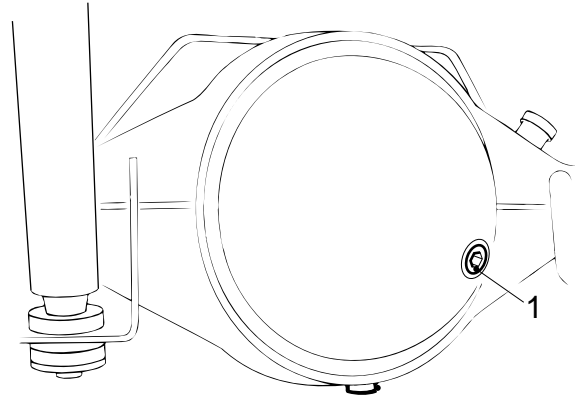

A8 00 375

3.2 ADJUSTING THE CROWN WHEEL GUIDE BOLT

1. Place chocks in front of the wheels and engage the parking brake.
2. Loosen the lock ring (1) and loosen the lock nut (2) a few turns.
3. Remove the adjusting screw (3) from the differential.
4. Remove the lock ring (1).
5. Remove any residual sealant from the adjusting screw and apply new sealant to the last 4 windings of the screw thread. See main group "Technical data".
6. Fit the adjusting screw with a new lock ring and tighten the adjusting screw against the crown wheel.
7. Turn the adjusting screw 1/8 stroke back to obtain the required play A.
8. Tighten the lock nut to the specified tightening torque. See main group "Technical data".

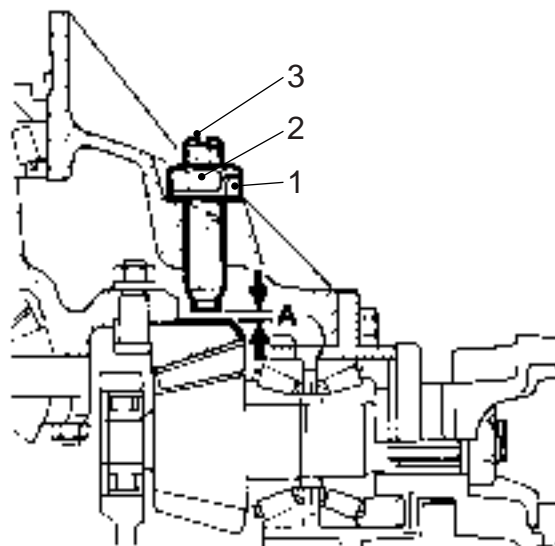

A8 00 429

Note:

Make sure that the adjusting screw does not turn while the lock nut is being tightened.

9. Secure the lock nut by folding the lips of the lock ring.

3.3 INSPECTION AND ADJUSTMENT, WHEEL BEARING PLAY

Inspecting the wheel bearing play

1. Remove the wheel.
2. Remove the stub axle.
3. Remove the brake pads.
4. Fit a micrometer gauge to the wheel hub, with the stylus on the end of the axle journal.
5. Push and pull the wheel hub. Check the wheel bearing play and compare it with the specified value. See main group "Technical data".

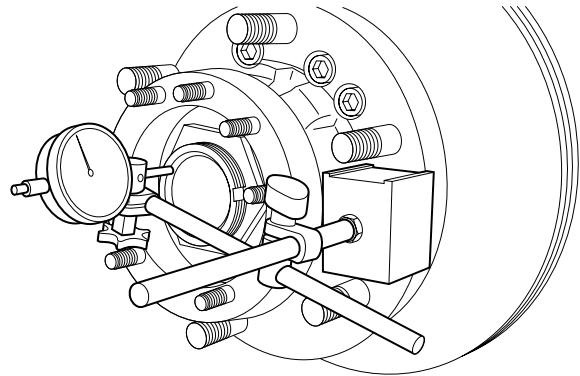

A8 00 387

3

Adjusting the wheel bearing play

1. Remove the lock nut.
2. Tighten the hub nut with a hub nut wrench (DAF No. 0499805) to 136 Nm.
3. Turn the hub two full rotations in order to "seat" the wheel bearings.
4. Mark (1) the hub nut wrench (2).
5. Turn the hub nut 2 strokes back.
6. Check the wheel bearing play.
7. Position the locking plate and fit the lock nut. Tighten the lock nut to the specified tightening torque. See main group "Technical data".
8. Secure the hub nut and lock nut with the locking plate.

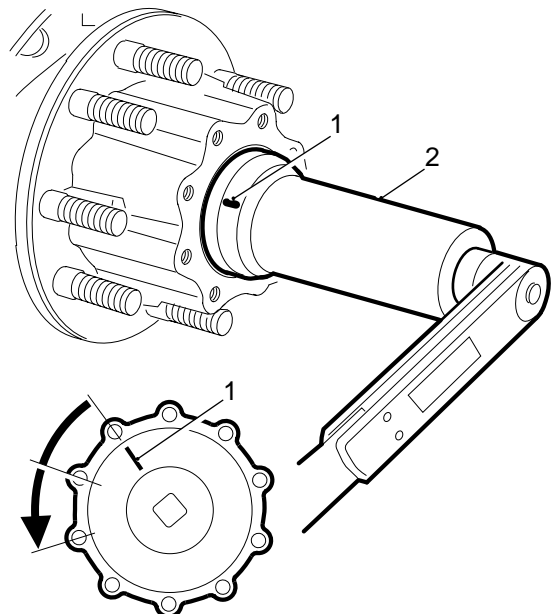

A8 00 380

3.4 INSPECTION, WHEEL-SPEED SENSOR RING

1. Check the sensor ring (2) for deposits. Special attention should be paid to deposits between the teeth of the sensor ring. Clean the sensor ring if necessary.
2. Check the sensor ring (2) for damage. Even the slightest damage may cause a failure. If necessary, replace the wheel hub.
3. Check the sensor (1) for smooth operation. If necessary, clean the sensor (1) and re-apply the specified anti-corrosion agent. See main group "Technical data".

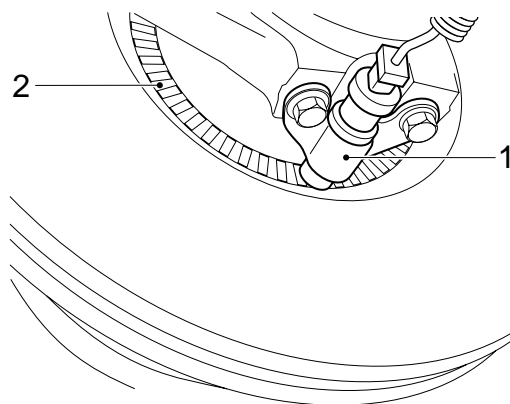

A8 00 391

3



Never tap the sensor with a hammer. This may damage both the sensor and the sensor ring.

4. Check the ABS system for proper operation.

4. REMOVAL AND INSTALLATION

4.1 REMOVAL AND INSTALLATION, STUB AXLES

Removing stub axles

1. Jack up the rear axle and support it on stands.
2. Remove the stub axle attachment nuts.
3. Remove the stub axle using a copper punch. When the stub axle comes loose, a small amount of oil may leak out. Collect this oil.

Installing stub axles

1. Clean the mating surfaces of the stub axle flange and wheel hub.
2. Apply the specified sealant to the mating surface of the stub axle flange. See main group "Technical data".
3. Fit the stub axle. Tighten the stub axle attachment nuts to the specified tightening torque. See main group "Technical data".

4.2 REMOVAL AND INSTALLATION, WHEEL HUB

Removing wheel hub

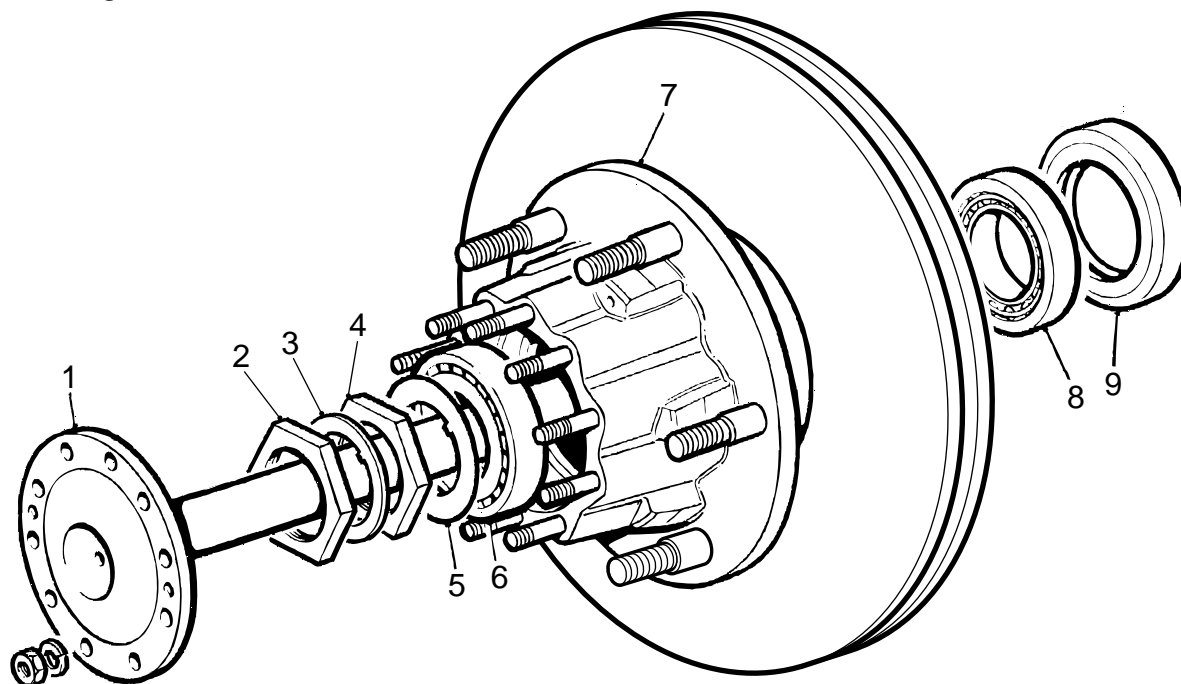

A8 00 394

1. Jack up the rear axle and support it on stands.
2. Remove the wheels.
3. Remove the brake caliper.
4. Remove the stub axle (1).
5. Remove the lock nut (2).
6. Remove the locking plate (3).
7. Remove the hub nut (4).
8. Remove the thrust washer (5).
9. Remove the wheel bearing inner race (6).
10. Remove the wheel hub from the axle journal.

Installing wheel hub

1. Check the wheel-speed sensor ring and the oil seal in the wheel hub for damage. Replace the oil seal if in doubt.
2. Check the axle journal screw thread carefully for damage.
3. Install the wheel hub on the axle journal. Slide the wheel hub onto the axle journal. Fit the wheel bearing inner race (6).
4. Fit the thrust washer (5).
5. Fit the hub nut (4).
6. Adjust the wheel bearing play, see chapter "Inspection and adjustment".
7. Fit the locking plate (3).
8. Fit the lock nut (2). Tighten the lock nut (2) to the specified tightening torque. See main group "Technical data".
9. Secure the lock nut (2) with the locking plate (3).
10. Press the wheel-speed sensor (1) against the sensor ring (2). When the vehicle is being driven, the air gap between the sensor and the sensor ring is adjusted automatically. If the sensor is stuck, remove, clean and refit it.



Never tap the sensor with a hammer. This may damage both the sensor and the sensor ring.

11. Fit the stub axle.
12. Fit the brake caliper.
13. Put the wheels back on.
14. Check the ABS system for proper operation.

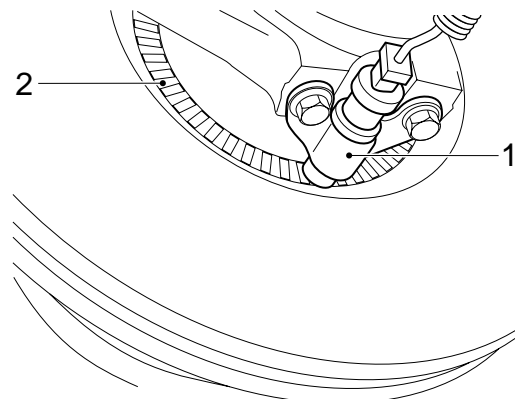

A8 00 391

4.3 REMOVAL AND INSTALLATION, HUB OIL SEAL

Removing hub oil seal

1. Remove the wheel hub from the axle journal.
2. Drill two holes into the oil seal and screw the special tool (B) (DAF No. 0484899) into the oil seal. Pull the oil seal from the pinion housing using the special tool (A) (DAF No. 0694928).

Installing hub oil seal

1. Use the special tool (DAF No. 0499809) to fit the oil seal such that the marking "outside" is pointing outward.
2. Install the wheel hub.

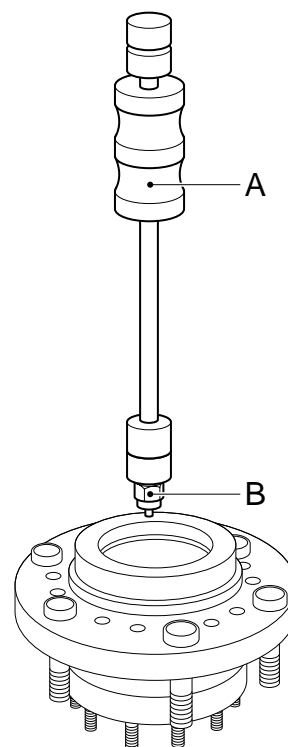

A8 00 392

4.4 REMOVAL AND INSTALLATION, WHEEL BEARING

Removing wheel bearing

1. Remove the wheel hub.
2. Remove the oil seal from the wheel hub.
3. There are recesses in the wheel hub for removing the wheel bearing outer race.
4. Remove the wheel bearing outer races from the wheel hub using a driver.

Installing wheel bearing

1. Fit the wheel bearing outer races in the wheel hub using a driver.
2. Fit the hub oil seal.
3. Install the wheel hub.

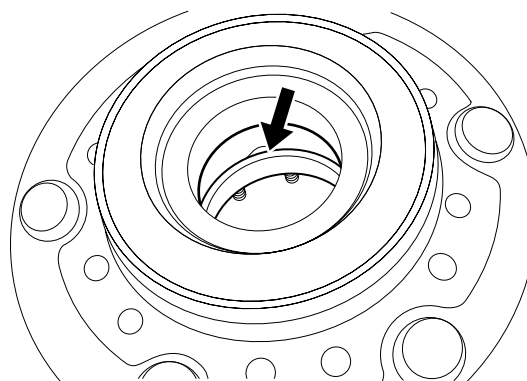

A8 00 393

4.5 REMOVAL AND INSTALLATION, WHEEL-SPEED SENSOR

Removing the wheel-speed sensor

1. Remove the wheel-speed sensor (1) from the holder (3).
2. Cut the clamping strips attaching the cable.
3. Unplug the connector and remove the wheel-speed sensor.

Installing the wheel-speed sensor

1. Clean the wheel-speed sensor (1) and the clamping sleeve (2). If necessary, replace the clamping sleeve (2).
2. Apply the specified anti-corrosion agent to the circumference of the wheel-speed sensor (1). See main group "Technical data".
3. Fit the wheel-speed sensor (1) in the holder (3). Press it against the sensor ring manually.
While the vehicle is being driven, the air gap between the sensor and the sensor ring is adjusted automatically.

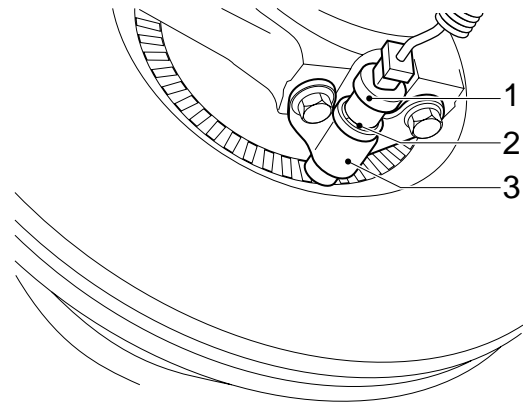

A8 00 435

3



Never tap the sensor with a hammer. This may damage both the sensor and the sensor ring.

4. Fit the connector and secure the cable with clamping strips.
5. Check the ABS system for proper operation.

4.6 REMOVAL AND INSTALLATION, DRIVE FLANGE**Removing drive flange**

1. Remove the prop shaft from the drive flange.
2. Fit the special tool (B) (DAF No. 0484977) on the drive flange to prevent it from turning. Remove the drive flange nut using a torque amplifier (A).
3. Remove the drive flange. If necessary, use a puller.

Installing drive flange

1. Before installation check the drive flange along the oil-seal running surface for grooves and/or sharp edges. If required, replace the drive flange.
2. Fit the drive flange.
3. Apply a small amount of oil to the abutting surface of the drive flange nut.
4. Fit a new drive flange nut.
5. Fit the special tool (B) (DAF No. 0484977) on the drive flange to prevent it from turning. Use a torque amplifier (A) to tighten the drive flange nut to the specified tightening torque. See main group "Technical data".
6. Fit the prop shaft to the drive flange.

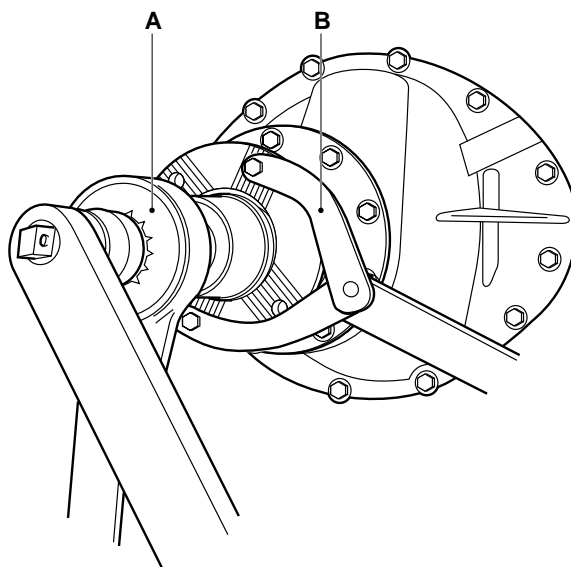

A8 00 386

4.7 REMOVAL AND INSTALLATION, PINION OIL SEAL

Removing pinion oil seal

1. Remove the drive flange.
2. Drill two holes into the oil seal and screw the special tool (B) (DAF No. 0484899) into the oil seal. Pull the oil seal from the pinion housing using the special tool (A) (DAF No. 0694928).

Installing pinion oil seal

1. Use the special tool (DAF No. 0485183) to fit the oil seal such that the marking "outside" is pointing outward.
2. Fit the drive flange.

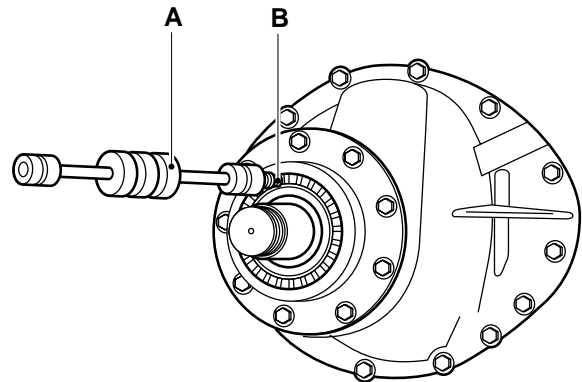

A8 00 381

4.8 REMOVAL AND INSTALLATION, DIFFERENTIAL**Removing differential**

1. Drain the oil from the differential. See chapter "Draining and filling".
2. Remove the prop shaft from the drive flange.
3. Remove the stub axles.
4. Attach the differential securely to a lifting device.
5. Remove the attachment bolts and nuts from the differential.
6. Remove the differential from the axle housing using two thrust bolts.

Installing differential

1. Clean the mating surfaces of the axle housing and the differential housing. Regrind the mating faces lightly. Do not damage the mating faces in the process.
2. Clean and degrease the bolts. Check the bolts and stud bolts for signs of damage.
3. Apply a thin, even layer of sealant to the mating surface and around the bolt holes of the axle housing.
4. Apply locking compound to the attachment bolts. See main group "Technical data".
5. Fit the differential into the axle housing. Fit the attachment bolts and nuts and tighten them evenly. Tighten the attachment bolts and nuts to the specified tightening torque. See "Technical data".
6. Fit the stub axles.
7. Fit the prop shaft to the drive flange.
8. Fill the differential with oil. See chapter "Draining and filling".

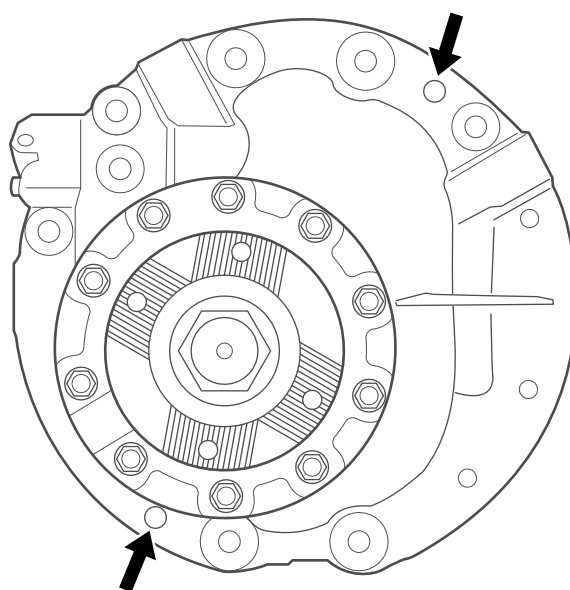

A8 00 378

5. DRAINING AND FILLING

5.1 DRAINING AND FILLING, DIFFERENTIAL



To prevent skin injury, avoid unnecessary contact with the drained oil.

Draining the differential

1. Position the vehicle on a level surface.
2. Place a suitable tray beneath the differential to collect the oil.
3. Remove the drain plug (1) and the level check/filler plug (2). Drain the oil.
4. Apply sealant to the screw thread of the drain plug (1). Install the drain plug (1) and tighten it to the specified tightening torque. See main group "Technical data".

Filling the differential

1. Fill the differential via the level check/filler plug (2) with the specified and correct quantity of oil. See main group "Technical data".
2. Check the oil level after 5 minutes; it should reach up to the level check/filler plug (2).
3. Apply sealant to the screw thread of the level check/filler plug (2). Fit the level check/filler plug (2).

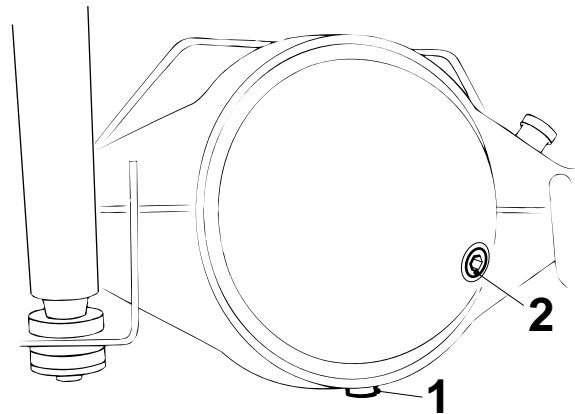

A8 00 370

5.2 DRAINING AND FILLING, WHEEL HUBS



To prevent skin injury, avoid unnecessary contact with the drained oil.

Note:

The design of the hub and the location of the drain/filler plug may differ from the illustration, depending on the version.

Draining wheel hub

1. Position the vehicle on a level surface.
2. Position the wheels in such a way that the oil drain/filler plug (1) is at the bottom.
3. Place a suitable tray under the hub to collect the oil. Remove the oil drain/filler plug (1).
4. Drain the oil and let the oil leak out of the hub.

Filling wheel hub

1. Position the wheels in such a way that the oil drain/filler plug (1) is at the top.
2. Fill the wheel hub with the specified and correct quantity of oil. See main group "Technical data".
3. Apply sealant to the screw thread of the oil drain/filler plug (1). Fit the oil drain/filler plug (1) into the hub.

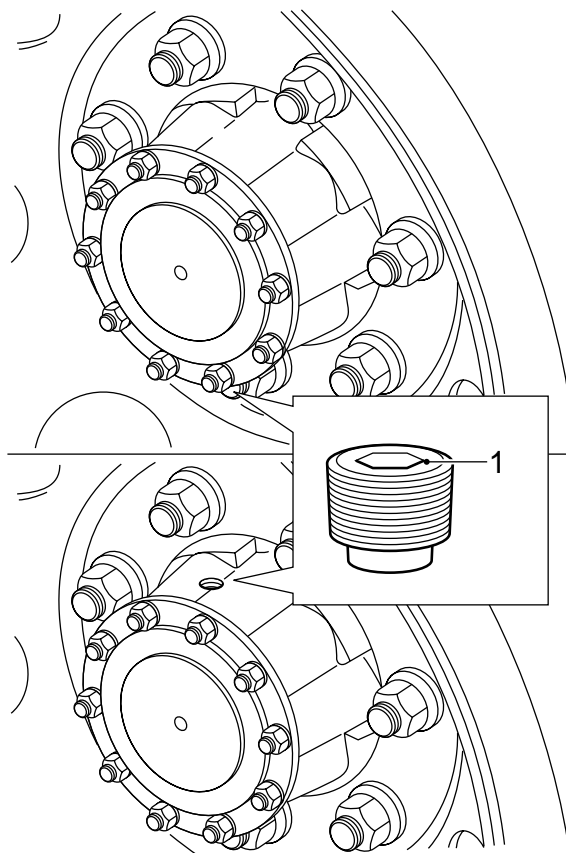

A8 00 369

CONTENTS

	Page	Date
1. SAFETY INSTRUCTIONS	1-1	200313
2. GENERAL	2-1	200313
2.1 Description of 5.14 axle	2-1	200313
2.2 Overview drawing, wheel hub	2-3	200313
3. INSPECTION AND ADJUSTMENT	3-1	200313
3.1 Inspecting differential oil level	3-1	200313
3.2 Checking operation of differential lock	3-1	200313
3.3 Inspection and adjustment, wheel bearing play	3-2	200313
3.4 Inspection, wheel-speed sensor ring	3-3	200313
4. REMOVAL AND INSTALLATION	4-1	200313
4.1 Removal and installation, stub axles	4-1	200313
4.2 Removal and installation, wheel hub	4-2	200313
4.3 Removal and installation, hub oil seal	4-4	200313
4.4 Removal and installation, wheel bearing	4-4	200313
4.5 Removal and installation, wheel-speed sensor	4-5	200313
4.6 Removal and installation, drive flange	4-6	200313
4.7 Removal and installation, pinion oil seal	4-7	200313
4.8 Removal and installation, differential	4-8	200313
4.9 Removal and installation, differential lock of 5.14 axle	4-9	200313
5. DRAINING AND FILLING	5-1	200313
5.1 Draining and filling, differential	5-1	200313
5.2 Draining and filling, wheel hubs	5-2	200313

1. SAFETY INSTRUCTIONS



Always use stands to support the chassis or components when working under the vehicle.

Always use the appropriate lifting gear or approved hoists to remove and install heavy components. Attach the component securely to the lifting or hoisting gear.

2. GENERAL

2.1 DESCRIPTION OF 5.14 AXLE

Differential

The 5.14 axle has a differential with hypoid gearing.

A single reduction is applied.

The bevelled gear-to-pinion backlash is achieved using adjusting nuts.

The pre-load of the pinion bearings for the 5.14 axle is adjusted using shims which are placed between the bearing inner races.

The pinion housing of the 5.14 axle can be removed using jacking bolts.

Differential lock

The 5.14 axle is equipped with a variable differential-gear lock.

The satellite gear housing flange is fitted with spline tothing on the right-hand side. The left-hand side of the selector sleeve is equipped with similar tothing.

The selector sleeve has internal splines similar to those on the stub axle.

There is a groove on outside of the selector sleeve accommodating a fork which is attached to the engaging cylinder.

If the engaging cylinder is pressurised using the pneumatic switch, the selector sleeve tothing will mesh with the tothing of the satellite gear housing.

If the engaging cylinder is vented via the pneumatic switch, the spring will ensure that the lock is disengaged.

Wheel hub

The wheel hub has a wheel bearing and hub oil seal that can be replaced separately. The wheel-speed sensor ring is integrated into the wheel hub. The wheel bearing play is adjusted using the hub nut. The correct wheel bearing pre-load is achieved by fitting the hub nut as specified.

The hub nut is secured with a lock nut and a locking plate.

The wheel bearing is greased by the oil in the hub.

The stub axle and brake disc are attached to the wheel hub with attachment nuts and bolts respectively.

2.2 OVERVIEW DRAWING, WHEEL HUB

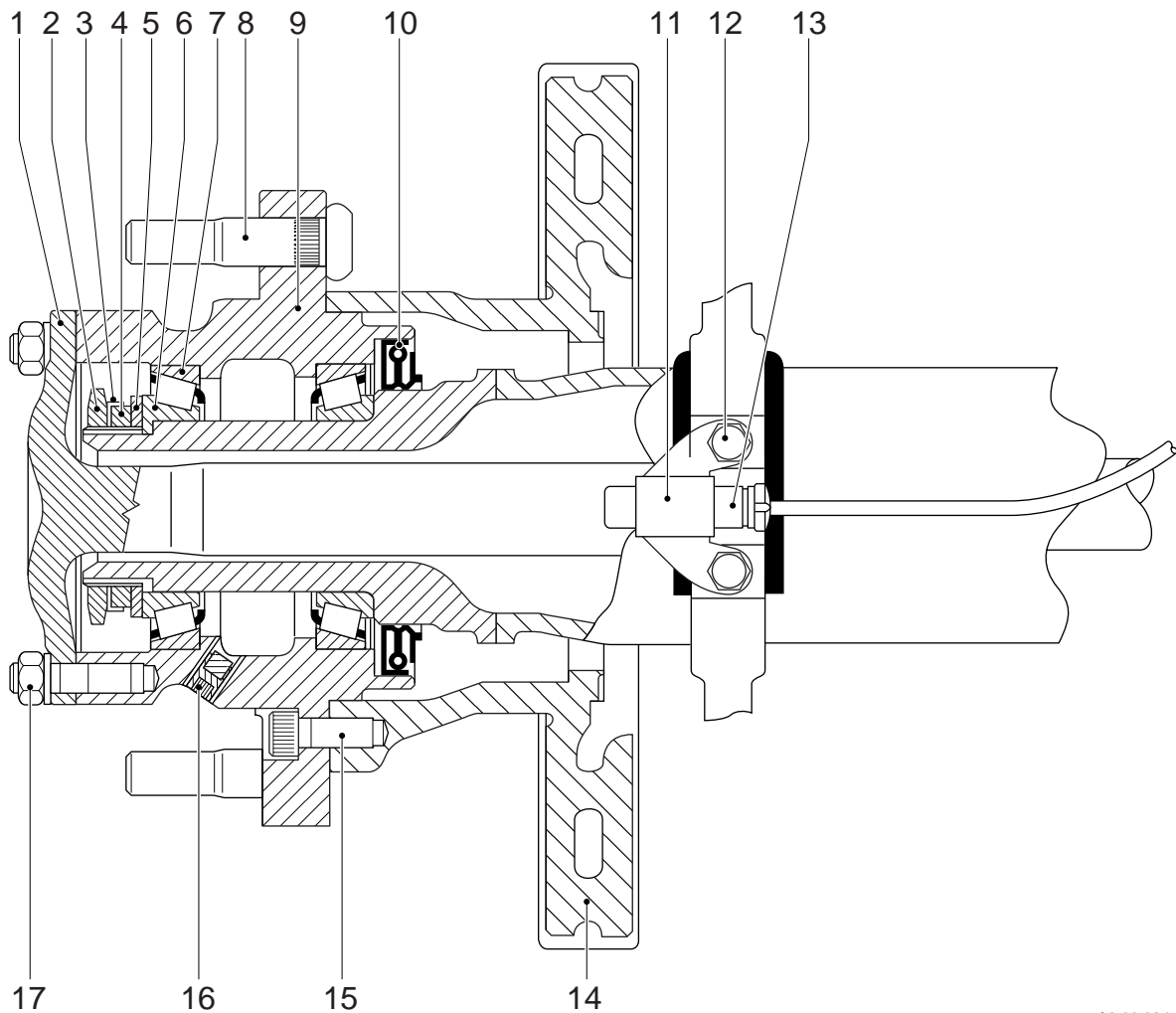

A8 00 384

Legend

- | | |
|-----------------------------|------------------------------------------------|
| 1. Stub axle | 10. Hub oil seal |
| 2. Lock nut | 11. Wheel-speed sensor holder |
| 3. Locking plate | 12. Wheel-speed sensor holder attachment bolts |
| 4. Hub nut | 13. Wheel-speed sensor |
| 5. Thrust washer | 14. Brake disc |
| 6. Wheel bearing inner race | 15. Brake disc attachment bolt |
| 7. Wheel bearing outer race | 16. Drain plug |
| 8. Wheel stud | 17. Stub axle attachment nut |
| 9. Wheel hub | |

3. INSPECTION AND ADJUSTMENT

3.1 INSPECTING DIFFERENTIAL OIL LEVEL



To prevent skin injury, avoid unnecessary contact with the drained oil.

1. Position the vehicle on a level surface.
2. Remove the level check/filler plug (1). The oil level must reach the level check/filler opening (1).
3. Apply sealant to the plug. Secure the plug.

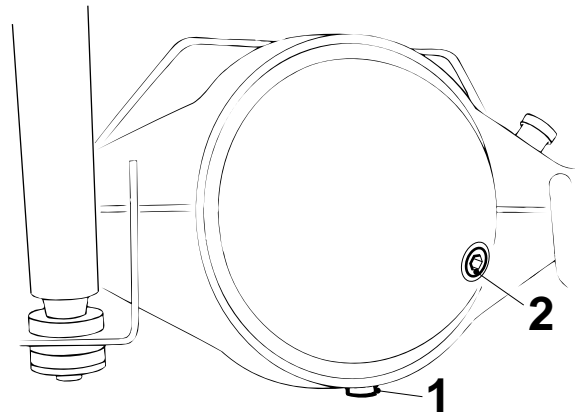

A8 00 370

4

3.2 CHECKING OPERATION OF DIFFERENTIAL LOCK

1. Jack up the rear axle and support it on stands.
2. Bring the air system to operating pressure.
3. Engage the differential lock. The warning indicator in the cab should now be activated.
4. Check whether there is a "rigid" connection between the driven wheels.
5. Disengage the differential lock. The warning indicator must no longer be activated and the "rigid" connection between the driven wheels should be interrupted.

3.3 INSPECTION AND ADJUSTMENT, WHEEL BEARING PLAY

Inspecting the wheel bearing play

1. Remove the wheel.
2. Remove the stub axle.
3. Remove the brake pads.
4. Fit a micrometer gauge to the wheel hub, with the stylus on the end of the axle journal.
5. Push and pull the wheel hub. Check the wheel bearing play and compare it with the specified value. See main group "Technical data".

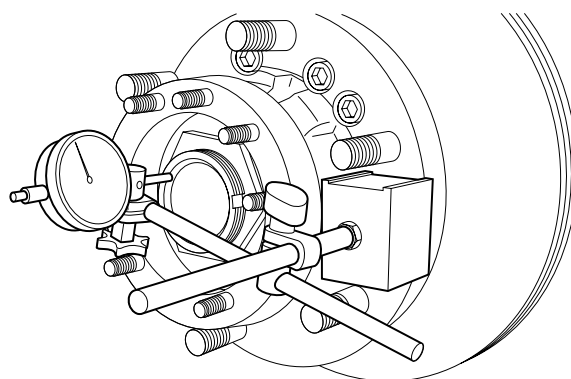

A8 00 387

Adjusting the wheel bearing play

1. Remove the lock nut.
2. Tighten the hub nut with a hub nut wrench (DAF No. 0499805) to 136 Nm.
3. Turn the hub two full rotations in order to "seat" the wheel bearings.
4. Mark (1) the hub nut wrench (2).
5. Turn the hub nut 2 strokes back.
6. Check the wheel bearing play.
7. Position the locking plate and fit the lock nut. Tighten the lock nut to the specified tightening torque. See main group "Technical data".
8. Secure the hub nut and lock nut with the locking plate.

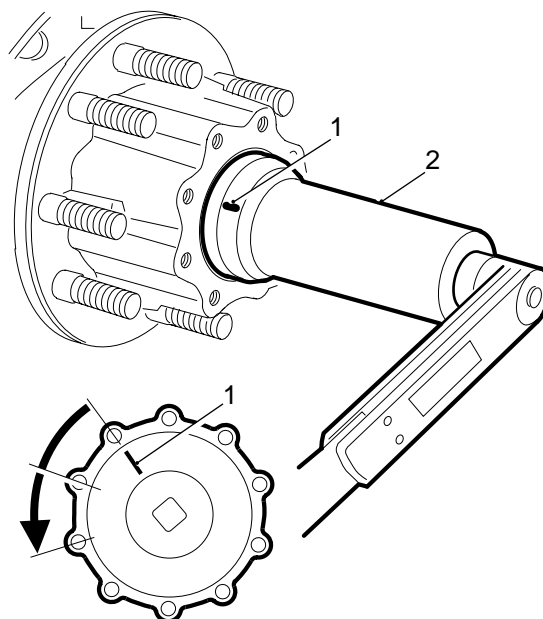

A8 00 380

3.4 INSPECTION, WHEEL-SPEED SENSOR RING

1. Check the sensor ring (2) for deposits. Special attention should be paid to deposits between the teeth of the sensor ring. Clean the sensor ring if necessary.
2. Check the sensor ring (2) for damage. Even the slightest damage may cause a failure. If necessary, replace the wheel hub.
3. Check the sensor (1) for smooth operation. If necessary, clean the sensor (1) and re-apply the specified anti-corrosion agent. See main group "Technical data".



Never tap the sensor with a hammer. This may damage both the sensor and the sensor ring.

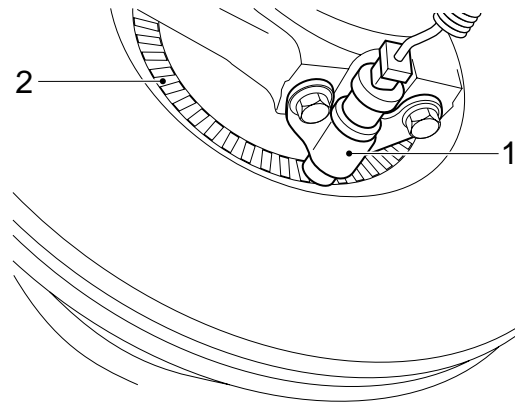

4. Check the ABS system for proper operation.

4. REMOVAL AND INSTALLATION

4.1 REMOVAL AND INSTALLATION, STUB AXLES

Removing stub axles

1. Jack up the rear axle and support it on stands.
2. Engage the differential lock, if applicable. Check that the axle is blocked. Replace the switch by the special tool (DAF No. 1329447), see (A). This is to prevent the selector sleeve from falling into the differential when removing the stub axle.
3. Remove the stub axle attachment nuts.
4. Remove the stub axle using a copper punch. When the stub axle comes loose, a small amount of oil may leak out. Collect this oil.

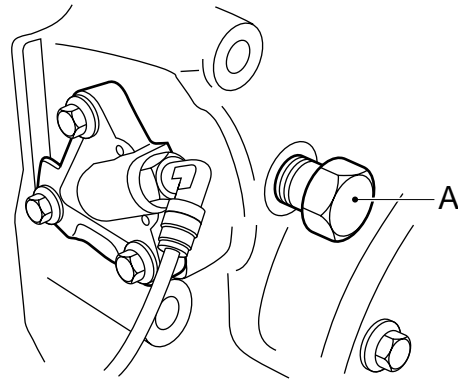

A8 00 396

Installing stub axles

1. Clean the mating surfaces of the stub axle flange and wheel hub.
2. Apply the specified sealant to the mating surface of the stub axle flange. See main group "Technical data".
3. Fit the stub axle. Tighten the stub axle attachment nuts to the specified tightening torque. See main group "Technical data".
4. Engage the differential lock, if applicable, and remove the special tool from the differential lock. Install the switch.

4.2 REMOVAL AND INSTALLATION, WHEEL HUB

Removing wheel hub

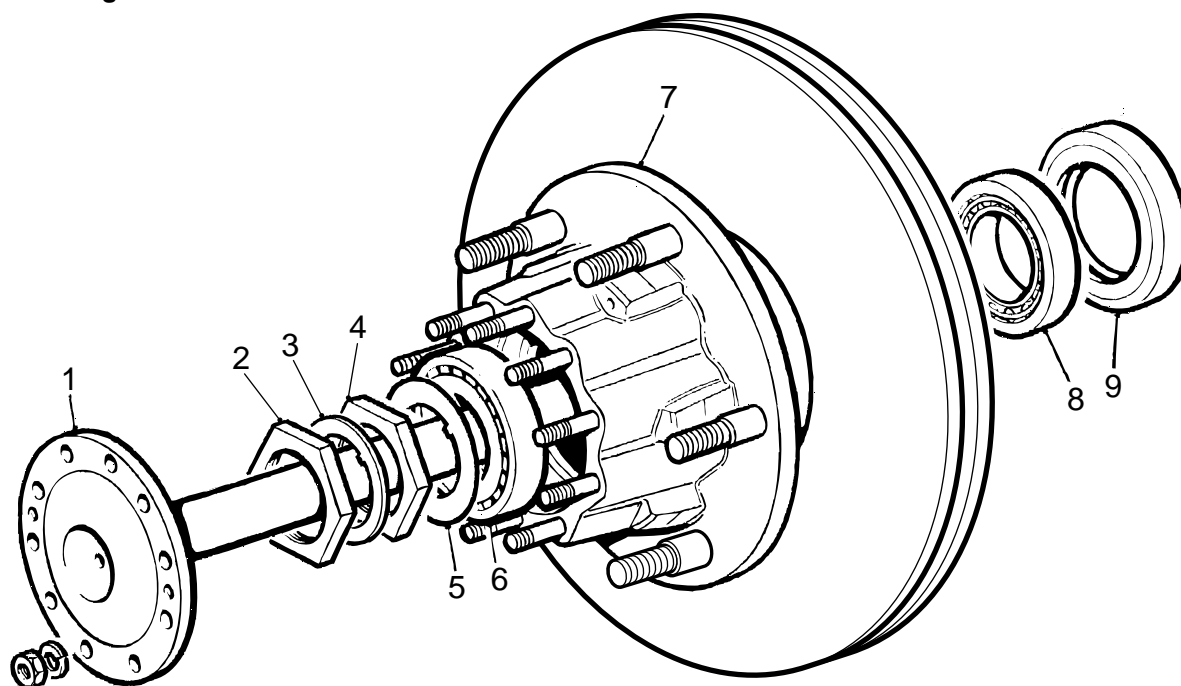

A8 00 394

1. Jack up the rear axle and support it on stands.
2. Remove the wheels.
3. Remove the brake caliper.
4. Remove the stub axle (1).
5. Remove the lock nut (2).
6. Remove the locking plate (3).
7. Remove the hub nut (4).
8. Remove the thrust washer (5).
9. Remove the wheel bearing inner race (6).
10. Remove the wheel hub from the axle journal.

Installing wheel hub

1. Check the wheel-speed sensor ring and the oil seal in the wheel hub for damage. Replace the oil seal if in doubt.
2. Check the axle journal screw thread carefully for damage.
3. Install the wheel hub on the axle journal. Slide the wheel hub onto the axle journal. Fit the wheel bearing inner race (6).
4. Fit the thrust washer (5).
5. Fit the hub nut (4).
6. Adjust the wheel bearing play, see chapter "Inspection and adjustment".
7. Fit the locking plate (3).
8. Fit the lock nut (2). Tighten the lock nut (2) to the specified tightening torque. See main group "Technical data".
9. Secure the lock nut (2) with the locking plate (3).
10. Press the wheel-speed sensor (1) against the sensor ring (2). When the vehicle is being driven, the air gap between the sensor and the sensor ring is adjusted automatically. If the sensor is stuck, remove, clean and refit it.



Never tap the sensor with a hammer. This may damage both the sensor and the sensor ring.

11. Fit the stub axle.
12. Fit the brake caliper.
13. Put the wheels back on.
14. Check the ABS system for proper operation.

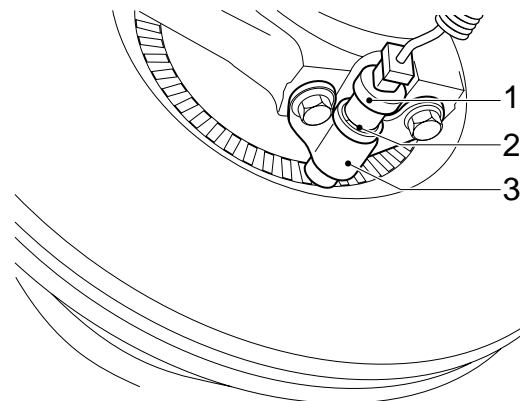

A8 00 435

4.3 REMOVAL AND INSTALLATION, HUB OIL SEAL

Removing hub oil seal

1. Remove the wheel hub from the axle journal.
2. Drill two holes into the oil seal and screw the special tool (B) (DAF No. 0484899) into the oil seal. Pull the oil seal from the pinion housing using the special tool (A) (DAF No. 0694928).

Installing hub oil seal

1. Use the special tool (DAF No. 0499809) to fit the oil seal such that the marking "outside" is pointing outward.
2. Install the wheel hub.

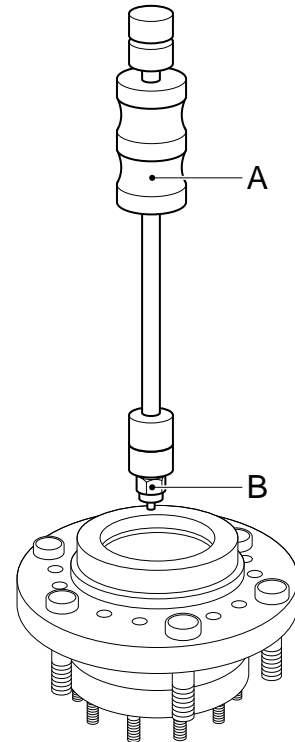

A8 00 392

4.4 REMOVAL AND INSTALLATION, WHEEL BEARING

Removing wheel bearing

1. Remove the wheel hub.
2. Remove the oil seal from the wheel hub.
3. There are recesses in the wheel hub for removing the wheel bearing outer race.
4. Remove the wheel bearing outer races from the wheel hub using a driver.

Installing wheel bearing

1. Fit the wheel bearing outer races in the wheel hub using a driver.
2. Fit the hub oil seal.
3. Install the wheel hub.

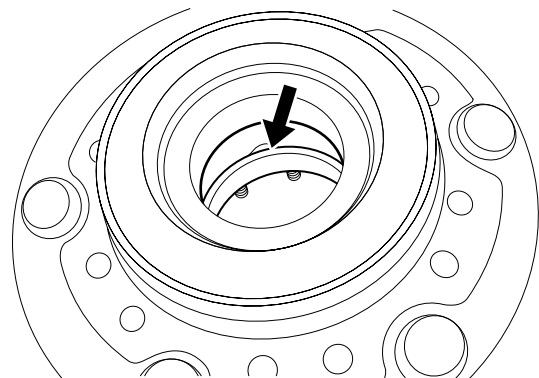

A8 00 393

4.5 REMOVAL AND INSTALLATION, WHEEL-SPEED SENSOR

Removing the wheel-speed sensor

1. Remove the wheel-speed sensor (1) from the holder (3).
2. Cut the clamping strips attaching the cable.
3. Unplug the connector and remove the wheel-speed sensor.

Installing the wheel-speed sensor

1. Clean the wheel-speed sensor (1) and the clamping sleeve (2). If necessary, replace the clamping sleeve (2).
2. Apply the specified anti-corrosion agent to the circumference of the wheel-speed sensor (1). See main group "Technical data".
3. Fit the wheel-speed sensor (1) in the holder (3). Press it against the sensor ring manually.
While the vehicle is being driven, the air gap between the sensor and the sensor ring is adjusted automatically.

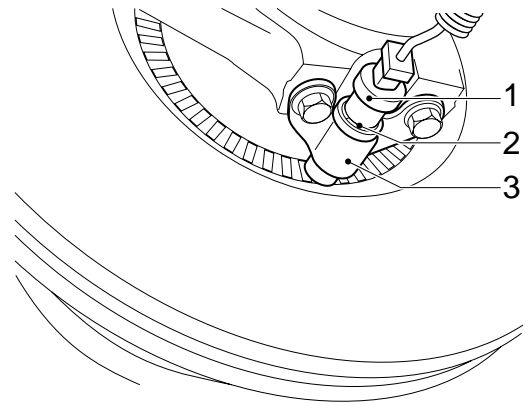

A8 00 435



Never tap the sensor with a hammer. This may damage both the sensor and the sensor ring.

4. Fit the connector and secure the cable with clamping strips.
5. Check the ABS system for proper operation.

4.6 REMOVAL AND INSTALLATION, DRIVE FLANGE**Removing drive flange**

1. Remove the prop shaft from the drive flange.
2. Fit the special tool (B) (DAF No. 0484977) on the drive flange to prevent it from turning. Remove the drive flange nut using a torque amplifier (A).
3. Remove the drive flange. If necessary, use a puller.

Installing drive flange

1. Before installation check the drive flange along the oil-seal running surface for grooves and/or sharp edges. If required, replace the drive flange.
2. Fit the drive flange.
3. Apply a small amount of oil to the abutting surface of the drive flange nut.
4. Fit a new drive flange nut.
5. Fit the special tool (B) (DAF No. 0484977) on the drive flange to prevent it from turning. Use a torque amplifier (A) to tighten the drive flange nut to the specified tightening torque. See main group "Technical data".
6. Fit the prop shaft to the drive flange.

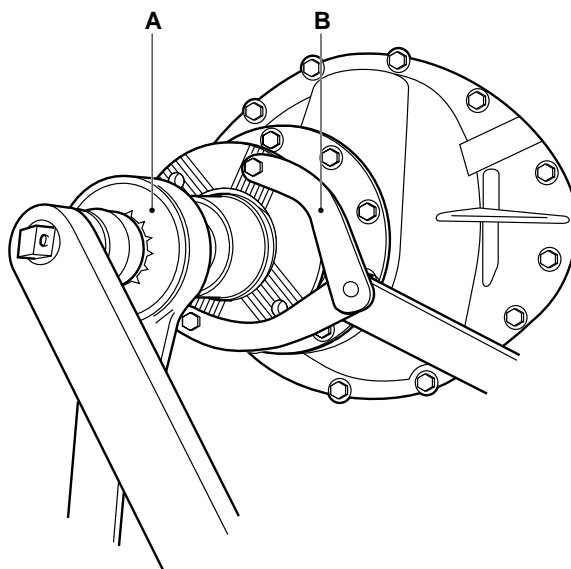

A8 00 386

4.7 REMOVAL AND INSTALLATION, PINION OIL SEAL

Removing pinion oil seal

1. Remove the drive flange.
2. Drill two holes into the oil seal and screw the special tool (B) (DAF No. 0484899) into the oil seal. Pull the oil seal from the pinion housing using the special tool (A) (DAF No. 0694928).

Installing pinion oil seal

1. Use the special tool (DAF No. 0485183) to fit the oil seal such that the marking "outside" is pointing outward.
2. Fit the drive flange.

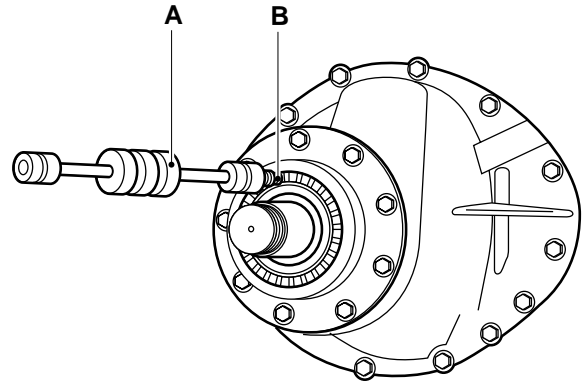

A8 00 381

4.8 REMOVAL AND INSTALLATION, DIFFERENTIAL**Removing differential**

1. Drain the oil from the differential. See chapter "Draining and filling".
2. Remove the prop shaft from the drive flange.
3. Remove the stub axles.
4. Remove the air connection for the differential lock, if applicable.
5. Attach the differential securely to a lifting device.
6. Remove the attachment bolts and nuts from the differential.
7. Remove the differential from the axle housing using two thrust bolts.

Installing differential

1. Clean the mating surfaces of the axle housing and the differential housing. Regrind the mating faces lightly. Do not damage the mating faces in the process.
2. Clean and degrease the bolts. Check the bolts and stud bolts for signs of damage.
3. Apply a thin, even layer of sealant to the mating surface and around the bolt holes of the axle housing.
4. Apply locking compound to the attachment bolts. See main group "Technical data".
5. Fit the differential into the axle housing. Fit the attachment bolts and nuts and tighten them evenly. Tighten the attachment bolts and nuts to the specified tightening torque. See "Technical data".
6. Fit the air connection to the differential lock.
7. Fit the stub axles.
8. Fit the prop shaft to the drive flange.
9. Fill the differential with oil. See chapter "Draining and filling".

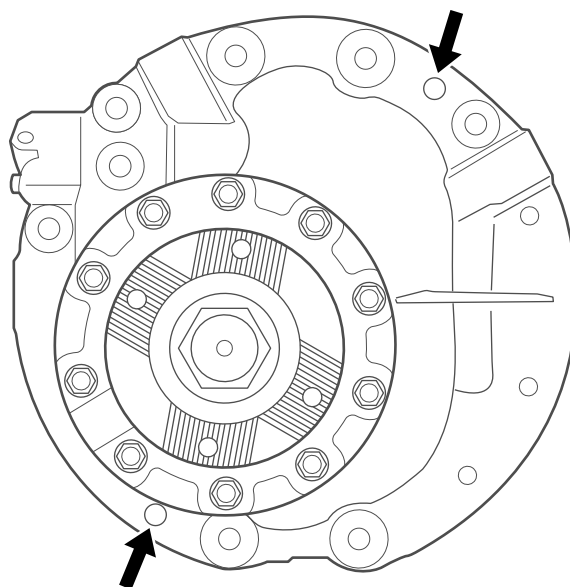

A8 00 378

4.9 REMOVAL AND INSTALLATION, DIFFERENTIAL LOCK OF 5.14 AXLE

Removing differential lock

1. Remove the differential.



Do not come near the selector sleeve when de-aerating the differential lock.

2. Pressurise the air connection of the differential lock. Remove the special tool (A). Evenly de-aerate the differential lock.
3. Remove the attachment bolts (1) from the cylinder cover (2). Remove the cover.

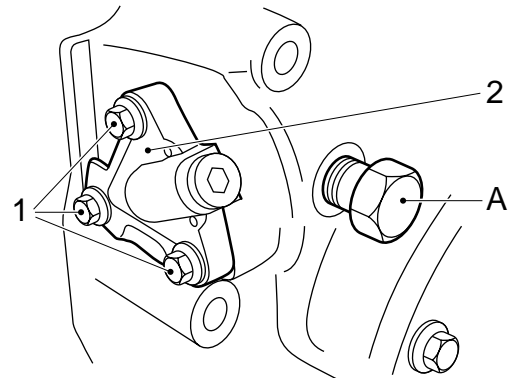

A8 00 395

4. Remove the piston (5).
5. Remove the shifting fork (2) and the selector sleeve (1) with the spring (3).

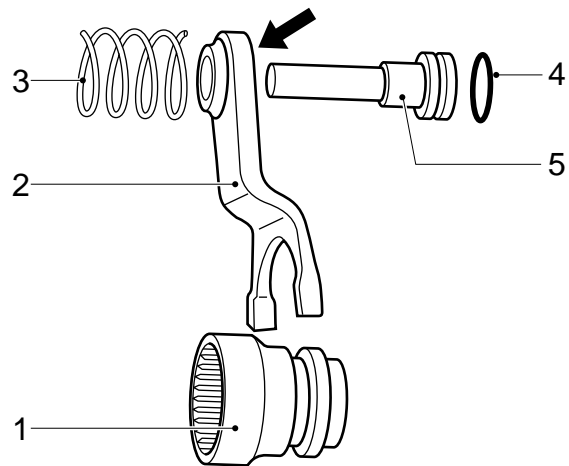

A8 00 383

Installing differential lock

1. Install the shifting fork (2) and selector sleeve (1) with the spring (3).

Note:

Make sure that the flat side (see arrow) of the shifting fork (2) points towards the piston (5).

2. Apply a small amount of oil to the seal (4) of the piston (5).
3. Install the piston (5).
4. Install the cylinder cover (2) and tighten the attachment bolts (1) evenly. Tighten the attachment bolts (1) to the specified tightening torque. See main group "Technical data".



Do not come near the selector sleeve when de-aerating the differential lock.

5. Pressurise the air connection of the differential lock. Fit special tool (A) (DAF No. 1329447), so that the differential lock is blocked.
6. Install the differential.

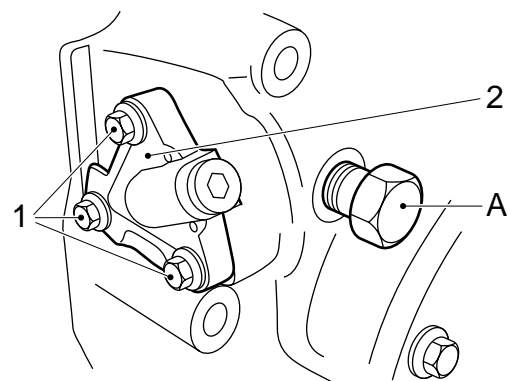

A8 00 395

5. DRAINING AND FILLING

5.1 DRAINING AND FILLING, DIFFERENTIAL



To prevent skin injury, avoid unnecessary contact with the drained oil.

Draining the differential

1. Position the vehicle on a level surface.
2. Place a suitable tray beneath the differential to collect the oil.
3. Remove the drain plug (1) and the level check/filler plug (2). Drain the oil.
4. Apply sealant to the screw thread of the drain plug (1). Install the drain plug (1) and tighten it to the specified tightening torque. See main group "Technical data".

Filling the differential

1. Fill the differential via the level check/filler plug (2) with the specified and correct quantity of oil. See main group "Technical data".
2. Check the oil level after 5 minutes; it should reach up to the level check/filler plug (2).
3. Apply sealant to the screw thread of the level check/filler plug (2). Fit the level check/filler plug (2).

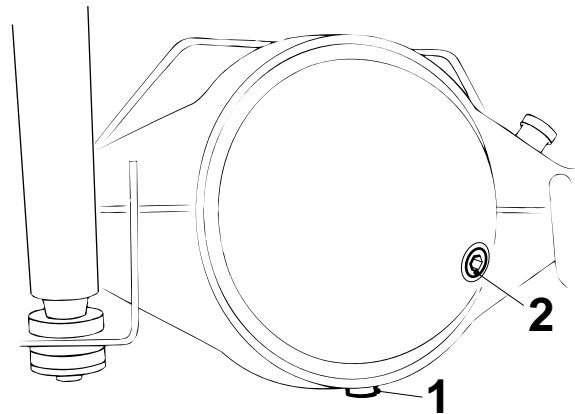

A8 00 370

5.2 DRAINING AND FILLING, WHEEL HUBS



To prevent skin injury, avoid unnecessary contact with the drained oil.

Note:

The design of the hub and the location of the drain/filler plug may differ from the illustration, depending on the version.

Draining wheel hub

1. Position the vehicle on a level surface.
2. Position the wheels in such a way that the oil drain/filler plug (1) is at the bottom.
3. Place a suitable tray under the hub to collect the oil. Remove the oil drain/filler plug (1).
4. Drain the oil and let the oil leak out of the hub.

Filling wheel hub

1. Position the wheels in such a way that the oil drain/filler plug (1) is at the top.
2. Fill the wheel hub with the specified and correct quantity of oil. See main group "Technical data".
3. Apply sealant to the screw thread of the oil drain/filler plug (1). Fit the oil drain/filler plug (1) into the hub.

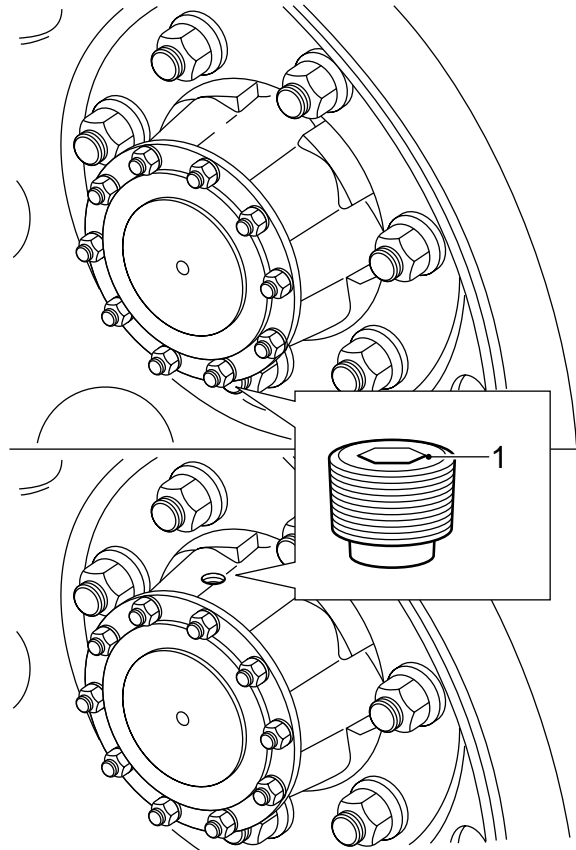

A8 00 369

CONTENTS

	Page	Date
1. SAFETY INSTRUCTIONS	1-1	200313
2. GENERAL	2-1	200313
2.1 Description of 8.20 axle	2-1	200313
2.2 Overview drawing, wheel hub	2-3	200313
3. INSPECTION AND ADJUSTMENT	3-1	200313
3.1 Inspecting differential oil level	3-1	200313
3.2 Checking operation of differential lock	3-1	200313
3.3 Inspection and adjustment, wheel bearing play	3-2	200313
3.4 Inspection, wheel-speed sensor ring	3-3	200313
4. REMOVAL AND INSTALLATION	4-1	200313
4.1 Removal and installation, stub axles	4-1	200313
4.2 Removal and installation, wheel hub	4-2	200313
4.3 Removal and installation, hub oil seal	4-4	200313
4.4 Removal and installation, wheel bearing	4-4	200313
4.5 Removal and installation, wheel-speed sensor	4-5	200313
4.6 Removal and installation, drive flange	4-6	200313
4.7 Removal and installation, pinion oil seal	4-7	200313
4.8 Removal and installation, differential	4-8	200313
4.9 Removal and installation, differential lock	4-9	200313
5. DRAINING AND FILLING	5-1	200313
5.1 Draining and filling, differential	5-1	200313
5.2 Draining and filling, wheel hubs	5-2	200313

1. SAFETY INSTRUCTIONS



Always use stands to support the chassis or components when working under the vehicle.

Always use the appropriate lifting gear or approved hoists to remove and install heavy components. Attach the component securely to the lifting or hoisting gear.

2. GENERAL

2.1 DESCRIPTION OF 8.20 AXLE

Differential

The 8.20 axle has a differential with hypoid gearing.

A single reduction is applied.

The bevelled gear-to-pinion backlash is achieved using adjusting nuts.

The pre-load of the pinion bearings is adjusted using shims which are placed between the bearing inner races.

The pinion housing can be removed using jacking bolts.

Differential lock

The 8.20 axle is equipped with a variable differential-gear lock.

The satellite gear housing flange is fitted with spline tooting on the right-hand side. The left-hand side of the selector sleeve is equipped with similar tooting.

The selector sleeve has internal splines similar to those on the stub axle.

There is a groove on outside of the selector sleeve accommodating a fork which is attached to the engaging cylinder.

If the engaging cylinder is pressurised using the pneumatic switch, the selector sleeve tooting will mesh with the tooting of the satellite gear housing.

If the engaging cylinder is vented via the pneumatic switch, the spring will ensure that the lock is disengaged.

Wheel hub

The wheel hub has a wheel bearing and hub oil seal that can be replaced separately. The wheel-speed sensor ring is integrated into the wheel hub. The wheel bearing play is adjusted using the hub nut. The correct wheel bearing pre-load is achieved by fitting the hub nut as specified.

The hub nut is secured with a lock nut and a locking plate.

The wheel bearing is greased by the oil in the hub.

The stub axle and brake disc are attached to the wheel hub with attachment nuts and bolts respectively.

2.2 OVERVIEW DRAWING, WHEEL HUB

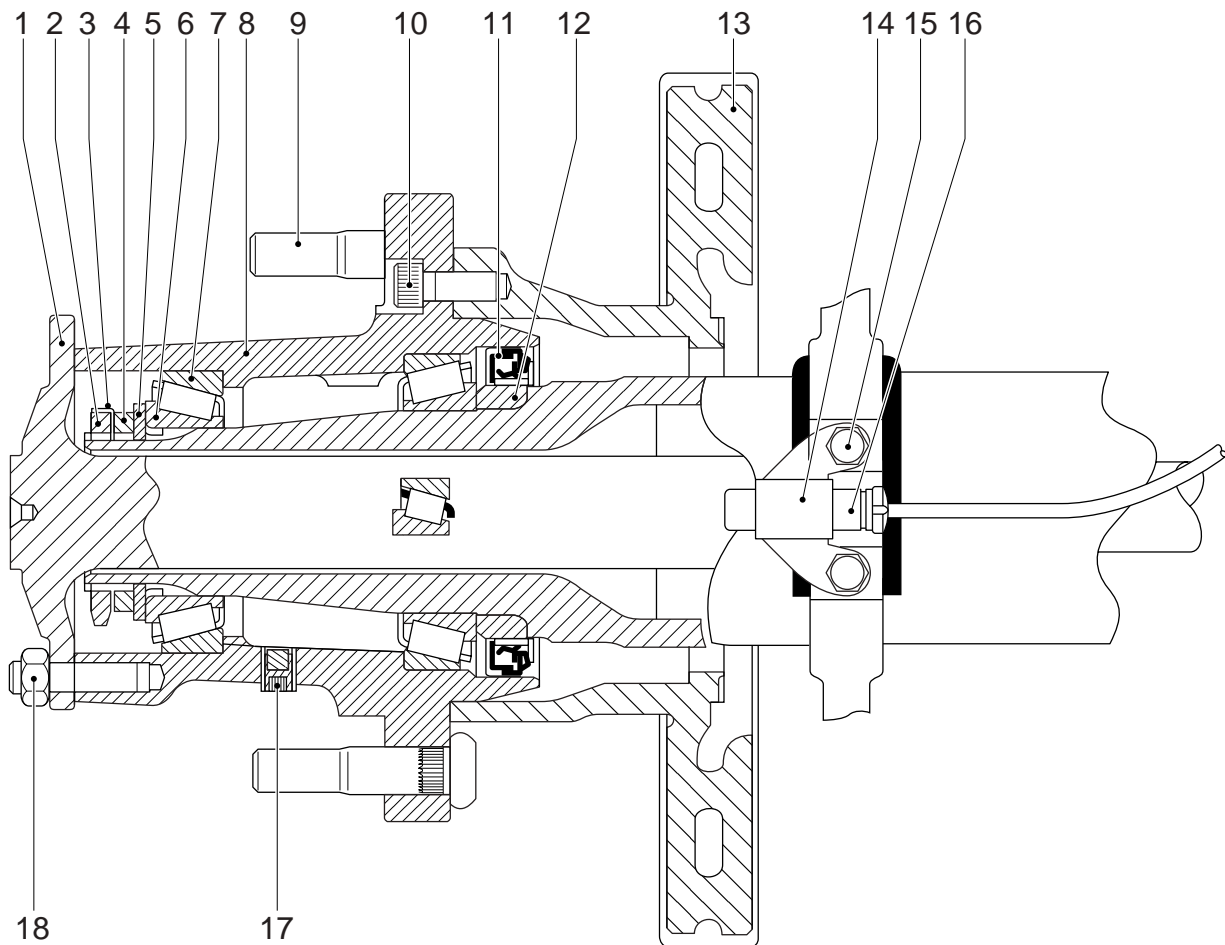

A8 00 385

Legend

- | | |
|--------------------------------|-----------------------------------------------|
| 1. Stub axle | 11. Hub oil seal |
| 2. Lock nut | 12. Race of hub oil seal |
| 3. Locking plate | 13. Brake disc |
| 4. Hub nut | 14. Wheel-speed sensor holder |
| 5. Thrust washer | 15. Wheel-speed sensor holder attachment bolt |
| 6. Wheel bearing inner race | 16. Wheel-speed sensor |
| 7. Wheel bearing outer race | 17. Drain plug |
| 8. Wheel hub | 18. Stub axle attachment nut |
| 9. Wheel stud | |
| 10. Brake disc attachment bolt | |

3. INSPECTION AND ADJUSTMENT

3.1 INSPECTING DIFFERENTIAL OIL LEVEL



To prevent skin injury, avoid unnecessary contact with the drained oil.

1. Position the vehicle on a level surface.
2. Remove the level check/filler plug (1). The oil level must reach the level check/filler opening (1).
3. Apply sealant to the plug. Secure the plug.

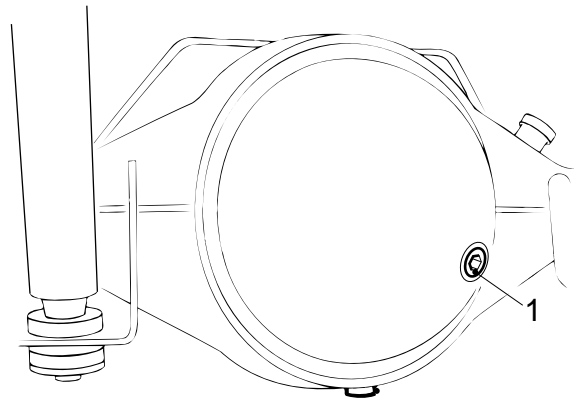

A8 00 375

5

3.2 CHECKING OPERATION OF DIFFERENTIAL LOCK

1. Jack up the rear axle and support it on stands.
2. Bring the air system to operating pressure.
3. Engage the differential lock. The warning indicator in the cab should now be activated.
4. Check whether there is a "rigid" connection between the driven wheels.
5. Disengage the differential lock. The warning indicator must no longer be activated and the "rigid" connection between the driven wheels should be interrupted.

3.3 INSPECTION AND ADJUSTMENT, WHEEL BEARING PLAY

Inspecting the wheel bearing play

1. Remove the wheel.
2. Remove the stub axle.
3. Remove the brake pads.
4. Fit a micrometer gauge to the wheel hub, with the stylus on the end of the axle journal.
5. Push and pull the wheel hub. Check the wheel bearing play and compare it with the specified value. See main group "Technical data".

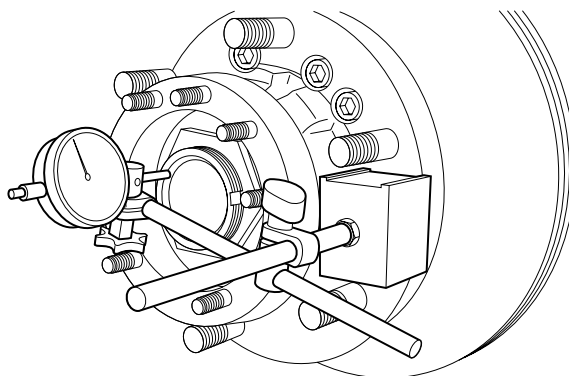

A8 00 387

5

Adjusting the wheel bearing play

1. Remove the lock nut.
2. Tighten the hub nut with a hub nut wrench (DAF No. 0499805) to 136 Nm.
3. Turn the hub two full rotations in order to "seat" the wheel bearings.
4. Mark (1) the hub nut wrench (2).
5. Turn the hub nut 2 strokes back.
6. Check the wheel bearing play.
7. Position the locking plate and fit the lock nut. Tighten the lock nut to the specified tightening torque. See main group "Technical data".
8. Secure the hub nut and lock nut with the locking plate.

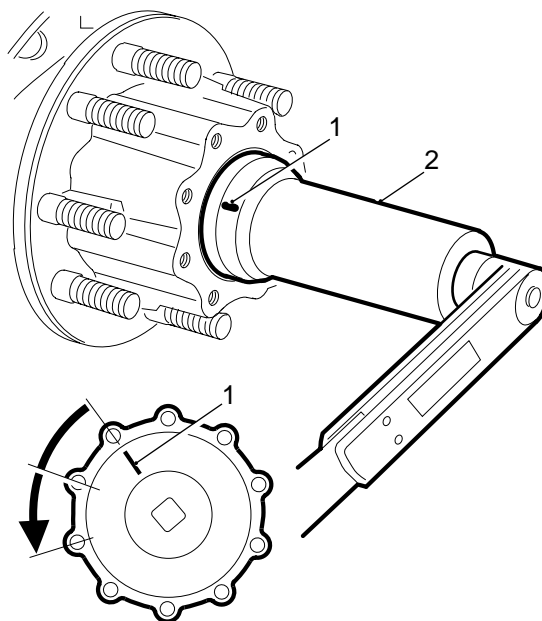

A8 00 380

3.4 INSPECTION, WHEEL-SPEED SENSOR RING

1. Check the sensor ring (2) for deposits. Special attention should be paid to deposits between the teeth of the sensor ring. Clean the sensor ring if necessary.
2. Check the sensor ring (2) for damage. Even the slightest damage may cause a failure. If necessary, replace the wheel hub.
3. Check the sensor (1) for smooth operation. If necessary, clean the sensor (1) and re-apply the specified anti-corrosion agent. See main group "Technical data".



Never tap the sensor with a hammer. This may damage both the sensor and the sensor ring.

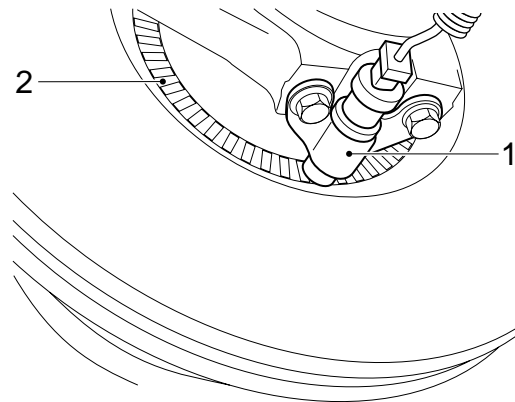

A8 00 391

4. Check the ABS system for proper operation.

4. REMOVAL AND INSTALLATION

4.1 REMOVAL AND INSTALLATION, STUB AXLES

Removing stub axles

1. Jack up the rear axle and support it on stands.
2. Engage the differential lock. Check that the axle is blocked. Replace the switch by the special tool (DAF No. 1329447), see (A). This is to prevent the selector sleeve from falling into the differential when removing the stub axle.
3. Remove the stub axle attachment bolts.
4. Remove the stub axle using a copper punch.
When the stub axle comes loose, a small amount of oil may leak out. Collect this oil.

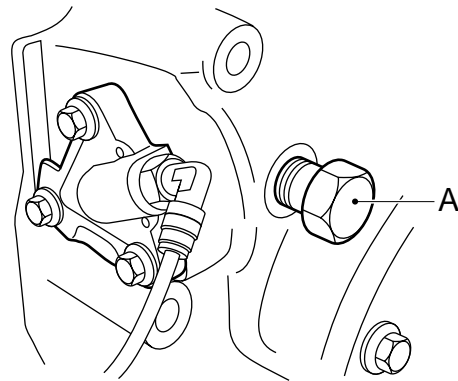

A8 00 396

Installing stub axles

1. Clean the mating surfaces of the stub axle flange and wheel hub.
2. Apply the specified sealant to the mating surface of the stub axle flange. See main group "Technical data".
3. Fit the stub axle. Tighten the stub axle attachment bolts to the specified tightening torque. See main group "Technical data".
4. Engage the differential lock and remove the special tool from the differential lock. Install the switch.

4.2 REMOVAL AND INSTALLATION, WHEEL HUB

Removing wheel hub

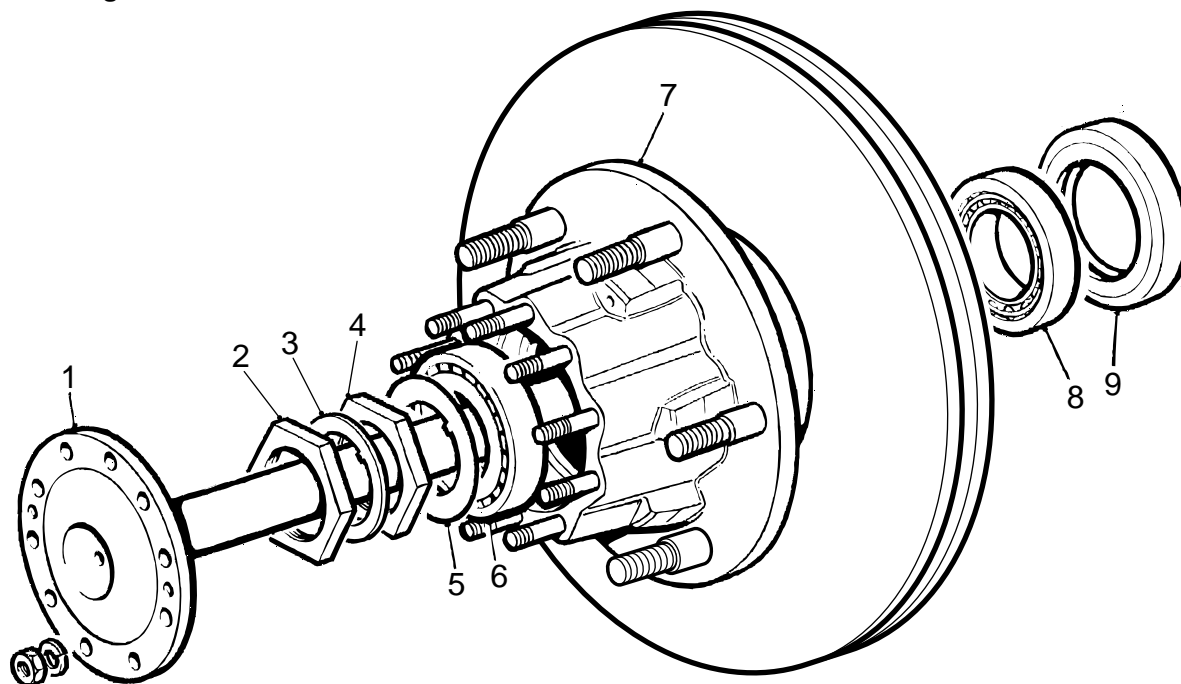

A8 00 394

1. Jack up the rear axle and support it on stands.
2. Remove the wheels.
3. Remove the brake caliper.
4. Remove the stub axle (1).
5. Remove the lock nut (2).
6. Remove the locking plate (3).
7. Remove the hub nut (4).
8. Remove the thrust washer (5).
9. Remove the wheel bearing inner race (6).
10. Remove the wheel hub from the axle journal.

Installing wheel hub

1. Check the wheel-speed sensor ring and the oil seal in the wheel hub for damage. Replace the oil seal if in doubt.
2. Check the axle journal screw thread carefully for damage.
3. Install the wheel hub on the axle journal. Slide the wheel hub onto the axle journal. Fit the wheel bearing inner race (6).
4. Fit the thrust washer (5).
5. Fit the hub nut (4).
6. Adjust the wheel bearing play, see chapter "Inspection and adjustment".
7. Fit the locking plate (3).
8. Fit the lock nut (2). Tighten the lock nut (2) to the specified tightening torque. See main group "Technical data".
9. Secure the lock nut (2) with the locking plate (3).
10. Press the wheel-speed sensor (1) against the sensor ring (2). When the vehicle is being driven, the air gap between the sensor and the sensor ring is adjusted automatically. If the sensor is stuck, remove, clean and refit it.



Never tap the sensor with a hammer. This may damage both the sensor and the sensor ring.

11. Fit the stub axle.
12. Fit the brake caliper.
13. Put the wheels back on.
14. Check the ABS system for proper operation.

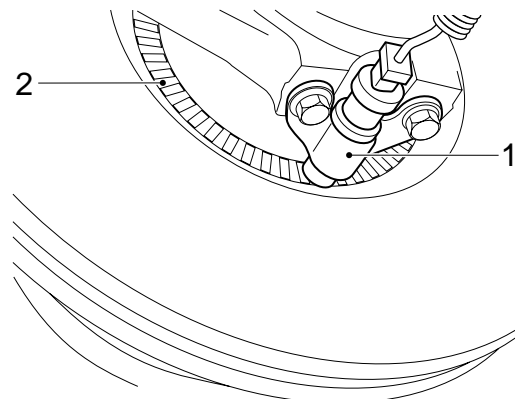

A8 00 391

4.3 REMOVAL AND INSTALLATION, HUB OIL SEAL

Removing hub oil seal

1. Remove the wheel hub from the axle journal.
2. Drill two holes into the oil seal and screw the special tool (B) (DAF No. 0484899) into the oil seal. Pull the oil seal from the pinion housing using the special tool (A) (DAF No. 0694928).

Installing hub oil seal

1. Use the special tool (DAF No. 1310453) to fit the oil seal such that the marking "outside" is pointing outward.
2. Install the wheel hub.

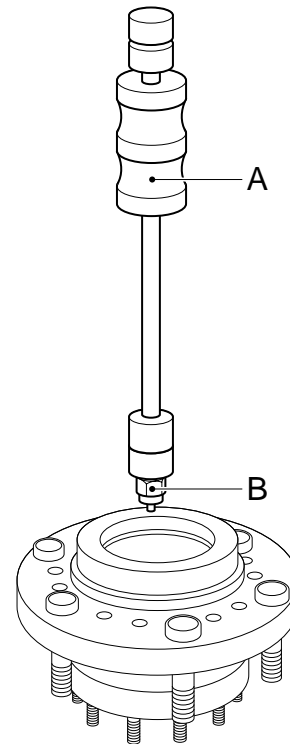

A8 00 392

4.4 REMOVAL AND INSTALLATION, WHEEL BEARING

Removing wheel bearing

1. Remove the wheel hub.
2. Remove the oil seal from the wheel hub.
3. There are recesses in the wheel hub for removing the wheel bearing outer race.
4. Remove the wheel bearing outer races from the wheel hub using a driver.

Installing wheel bearing

1. Fit the wheel bearing outer races in the wheel hub using a driver.
2. Fit the hub oil seal.
3. Install the wheel hub.

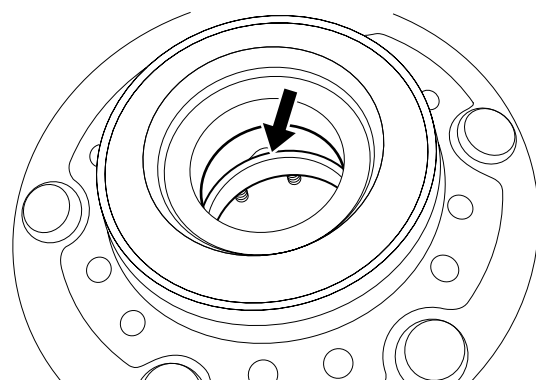

A8 00 393

4.5 REMOVAL AND INSTALLATION, WHEEL-SPEED SENSOR

Removing the wheel-speed sensor

1. Remove the wheel-speed sensor (1) from the holder (3).
2. Cut the clamping strips attaching the cable.
3. Unplug the connector and remove the wheel-speed sensor.

Installing the wheel-speed sensor

1. Clean the wheel-speed sensor (1) and the clamping sleeve (2). If necessary, replace the clamping sleeve (2).
2. Apply the specified anti-corrosion agent to the circumference of the wheel-speed sensor (1). See main group "Technical data".
3. Fit the wheel-speed sensor (1) in the holder (3). Press it against the sensor ring manually.
While the vehicle is being driven, the air gap between the sensor and the sensor ring is adjusted automatically.

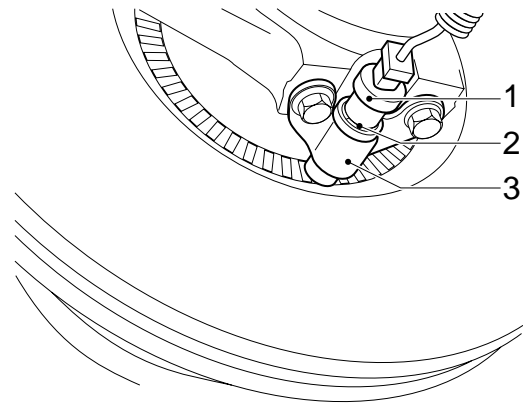

A8 00 435



Never tap the sensor with a hammer. This may damage both the sensor and the sensor ring.

4. Fit the connector and secure the cable with clamping strips.
5. Check the ABS system for proper operation.

4.6 REMOVAL AND INSTALLATION, DRIVE FLANGE**Removing drive flange**

1. Remove the prop shaft from the drive flange.
2. Fit the special tool (B) (DAF No. 0484977) on the drive flange to prevent it from turning. Remove the drive flange nut using a torque amplifier (A).
3. Remove the drive flange. If necessary, use a puller.

Installing drive flange

1. Before installation check the drive flange along the oil seal running surface for grooves and/or sharp edges. If required, replace the drive flange.
2. Fit the drive flange.
3. Apply a small amount of oil to the abutting surface of the drive flange nut.
4. Fit a new drive flange nut.
5. Fit the special tool (B) (DAF No. 0484977) on the drive flange to prevent it from turning. Use a torque amplifier (A) to tighten the drive flange nut to the specified tightening torque. See main group "Technical data".
6. Fit the prop shaft to the drive flange.

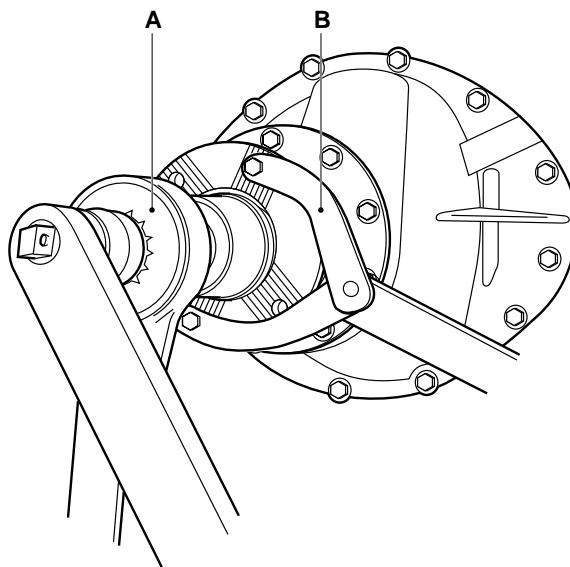

A8 00 386

4.7 REMOVAL AND INSTALLATION, PINION OIL SEAL

Removing pinion oil seal

1. Remove the drive flange.
2. Drill two holes into the oil seal and screw the special tool (B) (DAF No. 0484899) into the oil seal. Pull the oil seal from the pinion housing using the special tool (A) (DAF No. 0694928).

Installing pinion oil seal

1. Use the special tool (DAF No. 1310407) to fit the oil seal such that the marking "outside" is pointing outward.
2. Fit the drive flange.

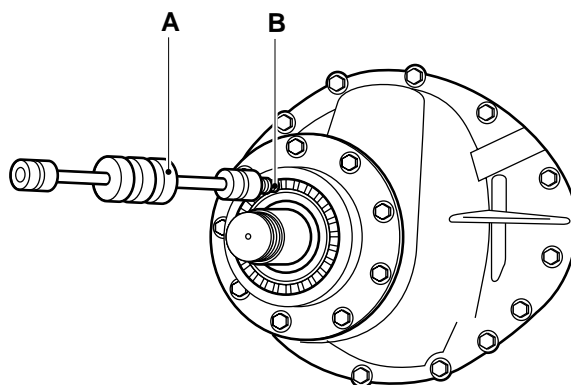

A8 00 381

4.8 REMOVAL AND INSTALLATION, DIFFERENTIAL**Removing differential**

1. Drain the oil from the differential. See chapter "Draining and filling".
2. Remove the prop shaft from the drive flange.
3. Remove the stub axles.
4. Remove the air connection for the differential lock, if applicable.
5. Attach the differential securely to a lifting device.
6. Remove the attachment bolts and nuts from the differential.
7. Remove the differential from the axle housing using two thrust bolts.

Installing differential

1. Clean the mating surfaces of the axle housing and the differential housing. Regrind the mating faces lightly. Do not damage the mating faces in the process.
2. Clean and degrease the bolts. Check the bolts and stud bolts for signs of damage.
3. Apply a thin, even layer of sealant to the mating surface and around the bolt holes of the axle housing.
4. Apply locking compound to the attachment bolts. See main group "Technical data".
5. Fit the differential into the axle housing. Fit the attachment bolts and nuts and tighten them evenly. Tighten the attachment bolts and nuts to the specified tightening torque. See "Technical data".
6. Fit the air connection to the differential lock.
7. Fit the stub axles.
8. Fit the prop shaft to the drive flange.
9. Fill the differential with oil. See chapter "Draining and filling".

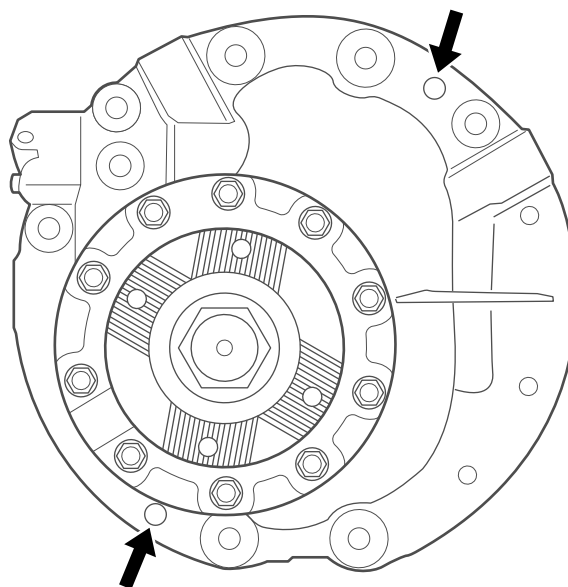

A8 00 378

4.9 REMOVAL AND INSTALLATION, DIFFERENTIAL LOCK

Removing differential lock

1. Remove the differential.



Do not come near the selector sleeve when de-aerating the differential lock.

2. Pressurise the air connection of the differential lock. Remove the special tool (A). Evenly de-aerate the differential lock.
3. Remove the attachment bolts (1) from the cylinder cover (2). Remove the cover.

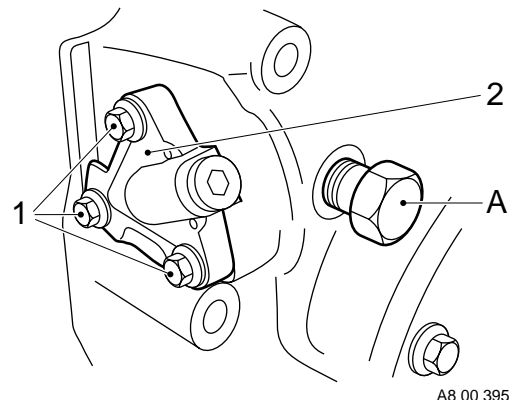

4. Remove the piston (5).
5. Remove the shifting fork (2) and the selector sleeve (1) with the spring (3).

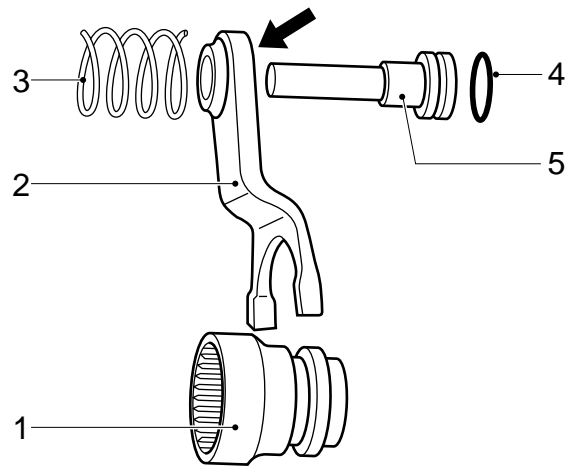
**Installing differential lock**

1. Install the shifting fork (2) and selector sleeve (1) with the spring (3).

Note:

Make sure that the flat side (see arrow) of the shifting fork (2) points towards the piston (5).

2. Apply a small amount of oil to the seal (4) of the piston (5).
3. Install the piston (5).
4. Install the cylinder cover (2) and tighten the attachment bolts (1) evenly. Tighten the attachment bolts (1) to the specified tightening torque. See main group "Technical data".



Do not come near the selector sleeve when de-aerating the differential lock.

5. Pressurise the air connection of the differential lock. Fit special tool (A) (DAF No. 1329447), so that the differential lock is blocked.
6. Install the differential.

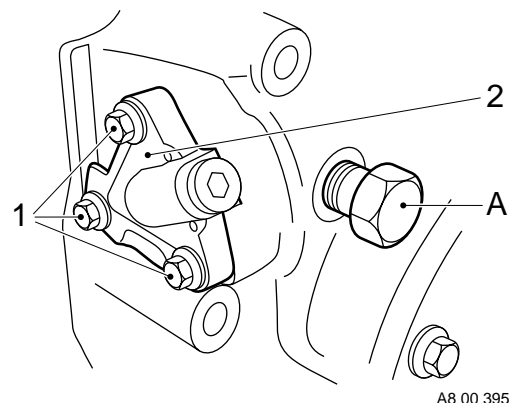

5. DRAINING AND FILLING

5.1 DRAINING AND FILLING, DIFFERENTIAL



To prevent skin injury, avoid unnecessary contact with the drained oil.

Draining the differential

1. Position the vehicle on a level surface.
2. Place a suitable tray beneath the differential to collect the oil.
3. Remove the drain plug (1) and the level check/filler plug (2). Drain the oil.
4. Apply sealant to the screw thread of the drain plug (1). Install the drain plug (1) and tighten it to the specified tightening torque. See main group "Technical data".

Filling the differential

1. Fill the differential via the level check/filler plug (2) with the specified and correct quantity of oil. See main group "Technical data".
2. Check the oil level after 5 minutes; it should reach up to the level check/filler plug (2).
3. Apply sealant to the screw thread of the level check/filler plug (2). Fit the level check/filler plug (2).

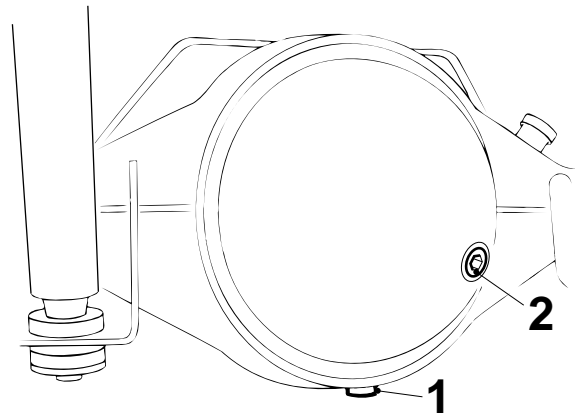

A8 00 370

5.2 DRAINING AND FILLING, WHEEL HUBS



To prevent skin injury, avoid unnecessary contact with the drained oil.

Note:

The design of the hub and the location of the drain/filler plug may differ from the illustration, depending on the version.

Draining wheel hub

1. Position the vehicle on a level surface.
2. Position the wheels in such a way that the oil drain/filler plug (1) is at the bottom.
3. Place a suitable tray under the hub to collect the oil. Remove the oil drain/filler plug (1).
4. Drain the oil and let the oil leak out of the hub.

Filling wheel hub

1. Position the wheels in such a way that the oil drain/filler plug (1) is at the top.
2. Fill the wheel hub with the specified and correct quantity of oil. See main group "Technical data".
3. Apply sealant to the screw thread of the oil drain/filler plug (1). Fit the oil drain/filler plug (1) into the hub.

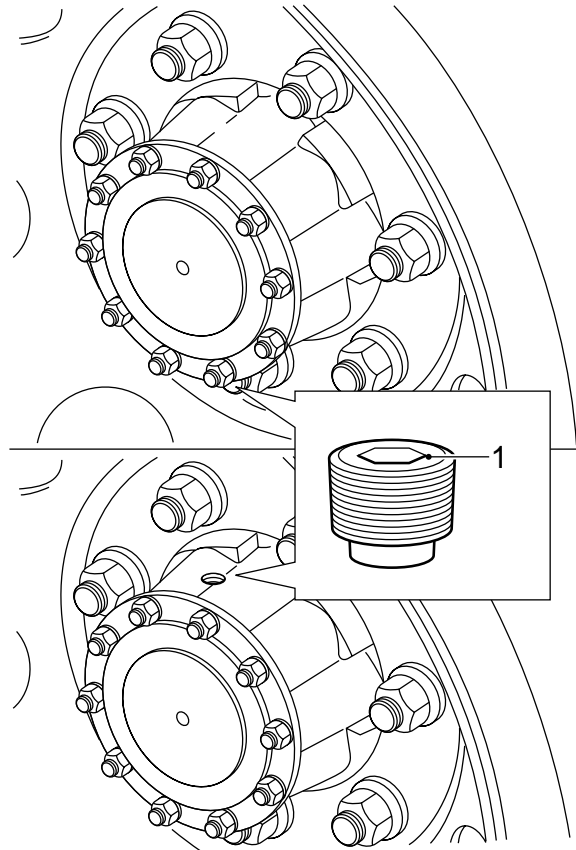

A8 00 369

CONTENTS

	Page	Date
1. SAFETY INSTRUCTIONS	1-1	200313
2. GENERAL	2-1	200313
2.1 Description of 10.20 axle	2-1	200313
2.2 Overview drawing, wheel hub	2-3	200313
3. INSPECTION AND ADJUSTMENT	3-1	200313
3.1 Inspecting differential oil level	3-1	200313
3.2 Checking operation of differential lock	3-1	200313
3.3 Inspection, wheel-speed sensor ring	3-2	200313
4. REMOVAL AND INSTALLATION	4-1	200313
4.1 Removal and installation, stub axles	4-1	200313
4.2 Removal and installation, wheel hub	4-2	200313
4.3 Removal and installation, compact bearing	4-5	200313
4.4 Removal and installation, wheel-speed sensor	4-6	200313
4.5 Removal and installation, drive flange	4-7	200313
4.6 Removal and installation, pinion oil seal	4-8	200313
4.7 Removal and installation, differential	4-9	200313
4.8 Removal and installation, differential lock	4-10	200313
5. DRAINING AND FILLING	5-1	200313
5.1 Draining and filling, differential	5-1	200313

1. SAFETY INSTRUCTIONS



Always use stands to support the chassis or components when working under the vehicle.

Always use the appropriate lifting gear or approved hoists to remove and install heavy components. Attach the component securely to the lifting or hoisting gear.

2. GENERAL

2.1 DESCRIPTION OF 10.20 AXLE

Differential

The 10.20 axle has a differential with hypoid gearing.

A single reduction is applied.

The bevelled gear-to-pinion backlash is achieved using adjusting nuts.

The pre-load of the pinion bearings is adjusted using shims which are placed between the bearing inner races.

The pinion housing can be removed using jacking bolts.

Differential lock

The 10.20 axle is equipped with a variable differential-gear lock.

The satellite gear housing flange is fitted with spline tothing on the right-hand side. The left-hand side of the selector sleeve is equipped with similar tothing.

The selector sleeve has internal splines similar to those on the stub axle.

There is a groove on outside of the selector sleeve accommodating a fork which is attached to the engaging cylinder.

If the engaging cylinder is pressurised using the pneumatic switch, the selector sleeve tothing will mesh with the tothing of the satellite gear housing.

If the engaging cylinder is vented via the pneumatic switch, the spring will ensure that the lock is disengaged.

Wheel hub

The wheel hub (3) has a compact bearing. The compact bearing and hub oil seal are a single unit. The compact bearing is retained on the rear side with a spring washer.

The thrust washer (2), which is located between the hub nut (1) and compact bearing, has a lip on the inside. This lip fits into a recess on the axle journal. This prevents the hub nut from loosening if any problems arise with the compact bearing. The hub nut is of the self-locking type. The nut is locked by bending the lips on the hub nut outward.

The compact bearing of the wheel hub is greased and is maintenance-free.

The correct wheel bearing pre-load is achieved by fitting the hub nut as specified. The stub axle and brake disc are attached to the wheel hub with bolts.

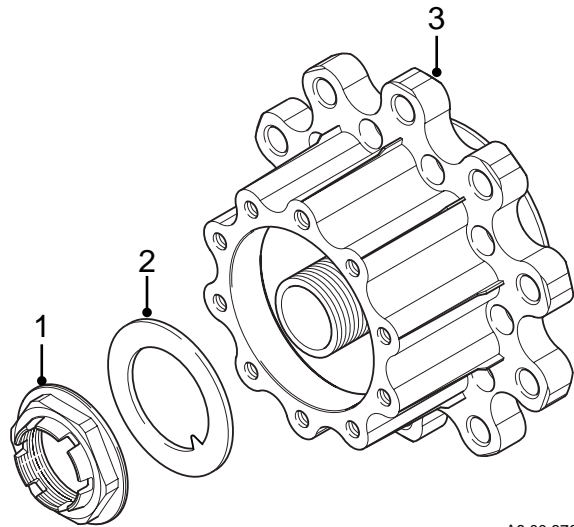

A8 00 376

2.2 OVERVIEW DRAWING, WHEEL HUB

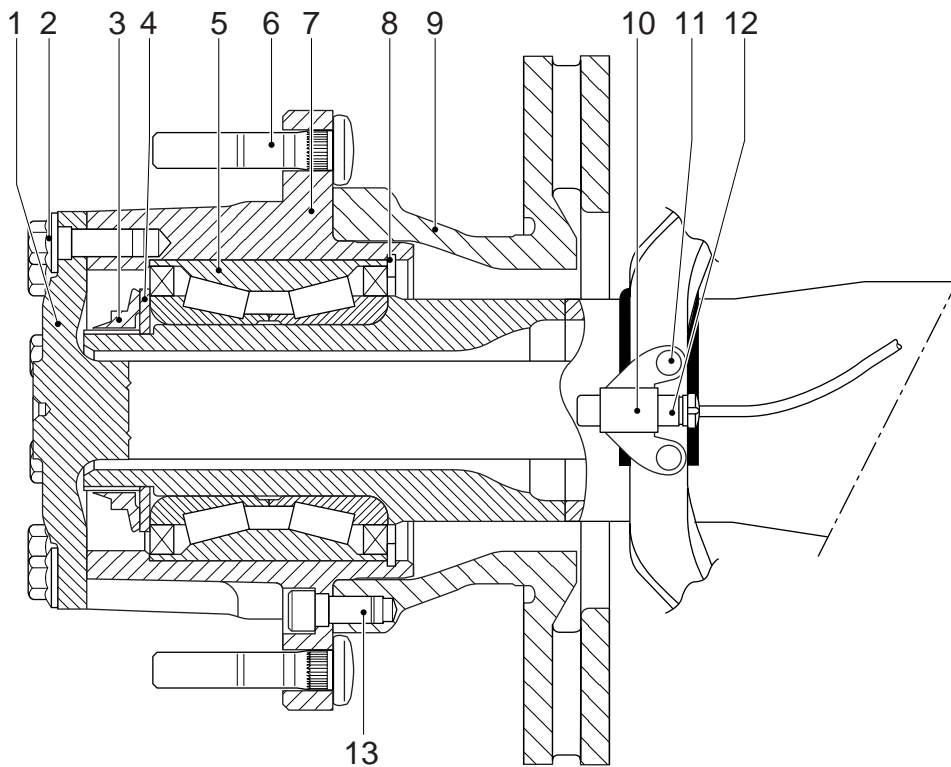

A8 00 374

Legend

1. Stub axle
2. Stub axle attachment bolt
3. Hub nut
4. Thrust washer
5. Compact bearing
6. Wheel stud
7. Wheel hub
8. Spring washer
9. Brake disc
10. Wheel-speed sensor holder
11. Wheel-speed sensor holder attachment bolts
12. Wheel-speed sensor
13. Brake disc attachment bolt

3. INSPECTION AND ADJUSTMENT

3.1 INSPECTING DIFFERENTIAL OIL LEVEL



To prevent skin injury, avoid unnecessary contact with the drained oil.

1. Position the vehicle on a level surface.
2. Remove the level check/filler plug (1). The oil level must reach the level check/filler opening (1).
3. Apply sealant to the plug. Secure the plug.

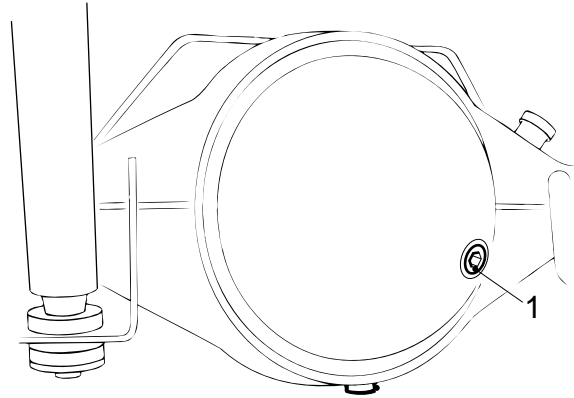

A8 00 375

3.2 CHECKING OPERATION OF DIFFERENTIAL LOCK

1. Jack up the rear axle and support it on stands.
2. Bring the air system to operating pressure.
3. Engage the differential lock. The warning indicator in the cab should now be activated.
4. Check whether there is a "rigid" connection between the driven wheels.
5. Disengage the differential lock. The warning indicator must no longer be activated and the "rigid" connection between the driven wheels should be interrupted.

3.3 INSPECTION, WHEEL-SPEED SENSOR RING

1. Remove the wheel hub.
2. Check the sensor ring (2) for deposits. Special attention should be paid to deposits between the teeth of the sensor ring. Clean the sensor ring if necessary.
3. Check the sensor ring (2) for damage. Even the slightest damage may cause a failure. If necessary, replace the wheel hub.
4. Check the sensor (1) for smooth operation. If necessary, clean the sensor (1) and re-apply the specified anti-corrosion agent. See main group "Technical data".

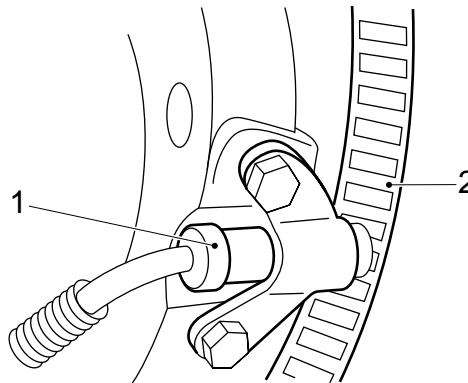

A8 00 379



Never tap the sensor with a hammer. This may damage both the sensor and the sensor ring.

5. Check the ABS system for proper operation.

4. REMOVAL AND INSTALLATION

4.1 REMOVAL AND INSTALLATION, STUB AXLES

Removing stub axles

1. Jack up the rear axle and support it on stands.
2. Engage the differential lock. Check that the axle is blocked. Replace the switch by the special tool (DAF No. 1329447), see (A). This is to prevent the selector sleeve from falling into the differential when removing the stub axle.

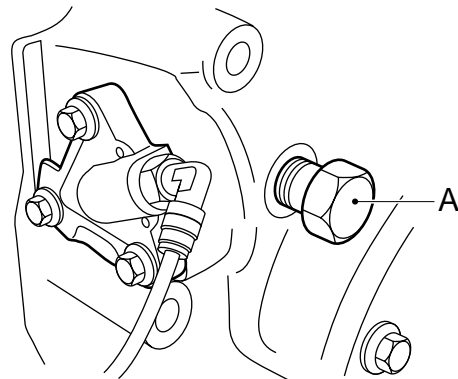

A8 00 396

3. Remove the stub axle attachment bolts.
4. Remove the stub axle using special tool (DAF No. 0694980), if required, see (B), or with a copper punch. When the stub axle comes loose, a small amount of oil may leak out. Collect this oil.

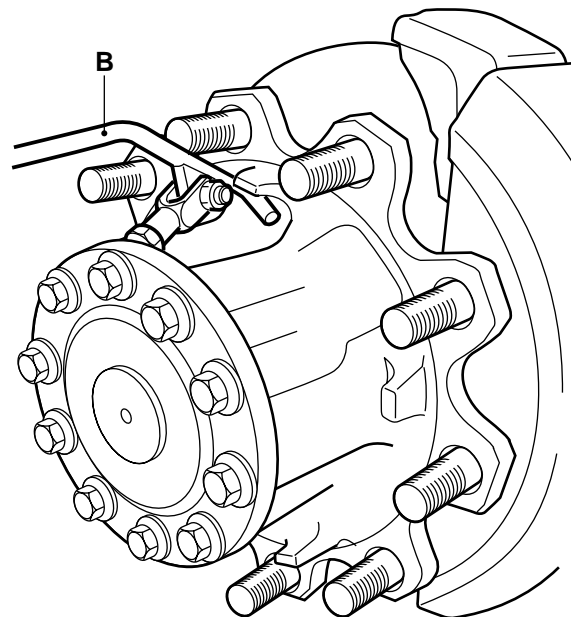

A8 00 382

Installing stub axles

1. Clean the mating surfaces of the stub axle flange and wheel hub.
2. Apply the specified sealant to the mating surface of the stub axle flange. See main group "Technical data".
3. Fit the stub axle. Tighten the stub axle attachment bolts to the specified tightening torque. See main group "Technical data".
4. Engage the differential lock and remove the special tool from the differential lock. Install the switch.

4.2 REMOVAL AND INSTALLATION, WHEEL HUB

Removing wheel hub

1. Jack up the rear axle and support it on stands.
2. Remove the wheels.
3. Remove the brake caliper.
4. Remove the stub axle.
5. Remove the hub nut (1) using special tool (A) (DAF No. 0535266) and a torque amplifier (B).
6. Remove the thrust washer (2).

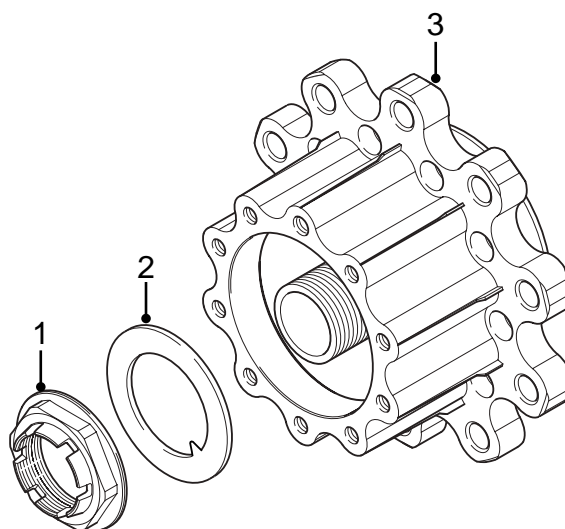

A8 00 376

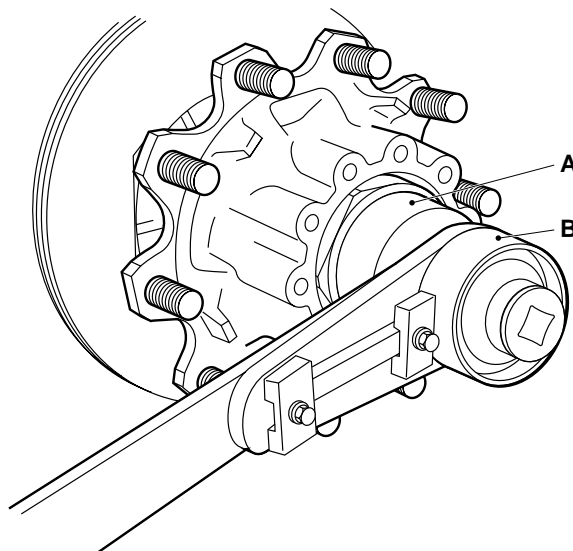

A8 00 355

7. Install the guide sleeve (A), special tool (DAF No. 1329490), on the axle journal.
8. Attach the wheel hub securely to a movable lifting device.
9. Slide the wheel hub from the axle journal using the lifting device.
Take care that the wheel hub does not rest on the guide sleeve (A) as the latter is not strong enough to take the weight of the wheel hub.

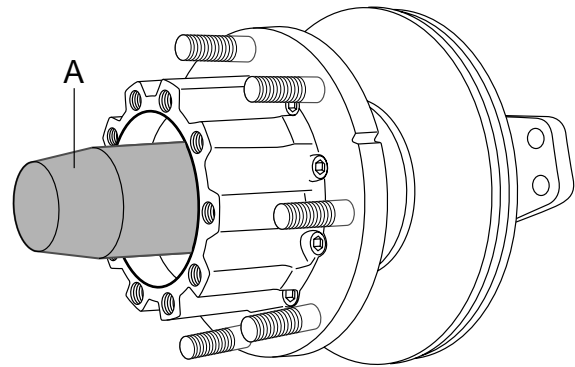

A8 00 389

Installing wheel hub

1. Check the wheel-speed sensor ring and the oil seals in the wheel hub for damage.
2. Check the axle journal screw thread carefully for damage.



You must never fit a wheel hub on an axle journal with damaged screw thread.

3. Apply a thin and even layer of the specified anti-corrosion agent to the axle journal. See main group "Technical data".

Note:

Do not apply too much anti-corrosion agent to the axle journal. When installing the wheel hub, the excess anti-corrosion agent will collect at the backside of the wheel hub. When the vehicle is used in daily operation, this anti-corrosion agent can leak out so that it looks as if the oil seal leaks.

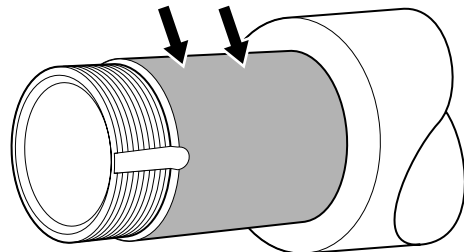

A8 00 390

4. Install the guide sleeve (A), special tool (DAF No. 1329490), on the axle journal.
5. Attach the wheel hub securely to a movable lifting device.
6. Position the wheel hub exactly in front of the axle journal using the movable lifting device. Slide the wheel hub onto the axle journal.
Take care that the wheel hub does not rest on the guide sleeve (A) as the latter is not strong enough to take the weight of the wheel hub.

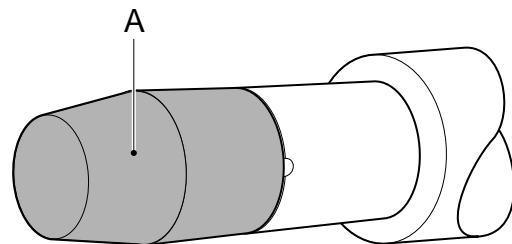

A8 00 397

7. Fit the thrust washer (2).
8. Replace the hub nut (1). Apply a few drops of oil to the abutting surface of the hub nut. Fit the hub nut.

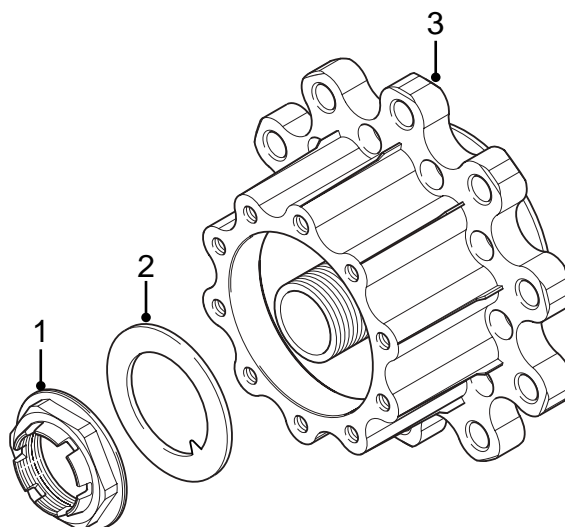

A8 00 376

9. Tighten the hub nut in the specified manner. See main group "Technical data". Use special tool (A) (DAF No. 0535266) and a torque amplifier (B) to do so.

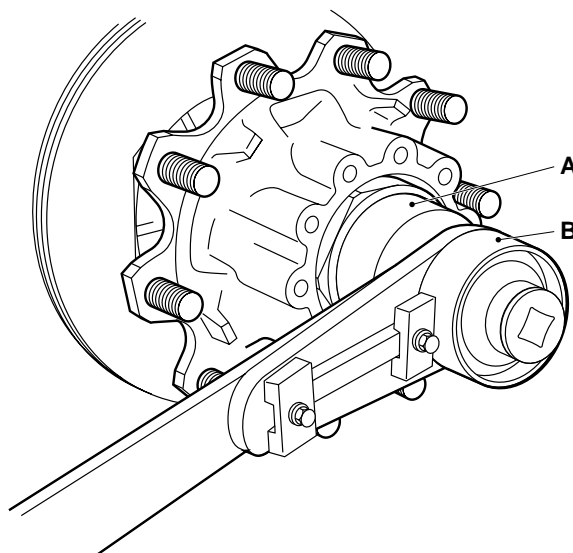

A8 00 355

10. Press the wheel-speed sensor (1) against the sensor ring (2).
When the vehicle is being driven, the air gap between the sensor and the sensor ring is adjusted automatically.
If the sensor is stuck, remove, clean and refit it.



Never tap the sensor with a hammer. This may damage both the sensor and the sensor ring.

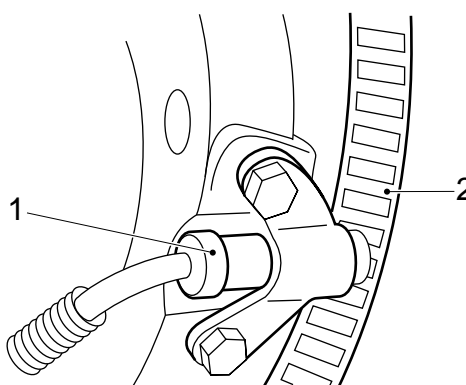

A8 00 379

11. Fit the stub axle.
12. Fit the brake caliper.
13. Put the wheels back on.
14. Check the ABS system for proper operation.

4.3 REMOVAL AND INSTALLATION, COMPACT BEARING

Removing compact bearing

1. Remove the wheel hub (1).
2. Remove the spring washer (3).
3. Remove the compact bearing (2) from the wheel hub using a press.

Installing compact bearing

1. Fit the compact bearing (2) to the wheel hub (1) using a press.
2. Fit the spring washer (3).
3. Install the wheel hub.

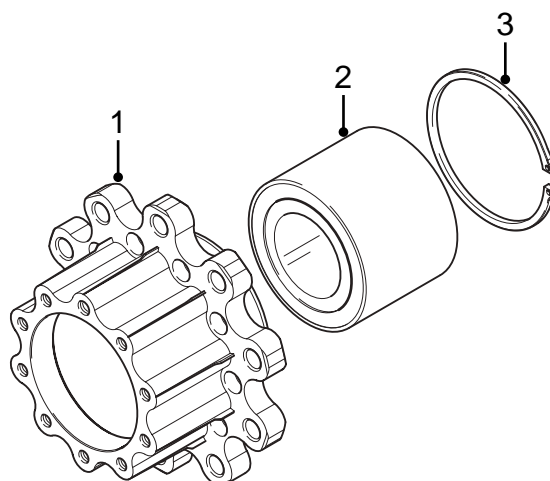

A8 00 377

4.4 REMOVAL AND INSTALLATION, WHEEL-SPEED SENSOR

Removing the wheel-speed sensor

1. Remove the wheel-speed sensor (1) from the holder (3).
2. Cut the clamping strips attaching the cable.
3. Unplug the connector and remove the wheel-speed sensor.

Installing the wheel-speed sensor

1. Clean the wheel-speed sensor (1) and the clamping sleeve (2). If necessary, replace the clamping sleeve (2).
2. Apply the specified anti-corrosion agent to the circumference of the wheel-speed sensor (1). See main group "Technical data".
3. Fit the wheel-speed sensor (1) in the holder (3). Press it against the sensor ring manually.
While the vehicle is being driven, the air gap between the sensor and the sensor ring is adjusted automatically.

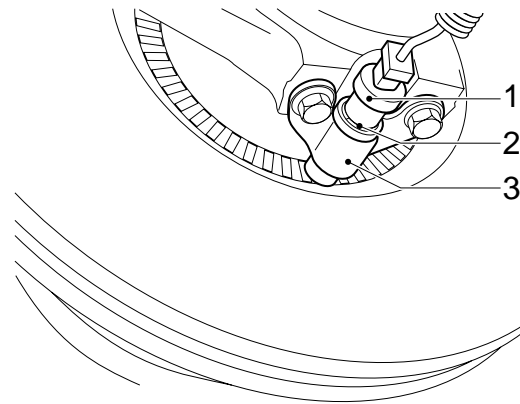

A8 00 435

6



Never tap the sensor with a hammer. This may damage both the sensor and the sensor ring.

4. Fit the connector and secure the cable with clamping strips.
5. Check the ABS system for proper operation.

4.5 REMOVAL AND INSTALLATION, DRIVE FLANGE

Removing drive flange

1. Remove the prop shaft from the drive flange.
2. Fit the special tool (B) (DAF No. 0484977) on the drive flange to prevent it from turning. Remove the drive flange nut using a torque amplifier (A).
3. Remove the drive flange. If necessary, use a puller.

Installing drive flange

1. Before installation check the drive flange along the oil seal running surface for grooves and/or sharp edges. If required, replace the drive flange.
2. Fit the drive flange.
3. Replace the drive-flange nut.
4. Apply a small amount of oil to the abutting surface of the drive flange nut.
5. Fit the special tool (B) (DAF No. 0484977) on the drive flange to prevent it from turning. Fit the drive-flange nut. Use a torque amplifier (A) to tighten the drive flange nut to the specified tightening torque. See main group "Technical data".
6. Fit the prop shaft to the drive flange.

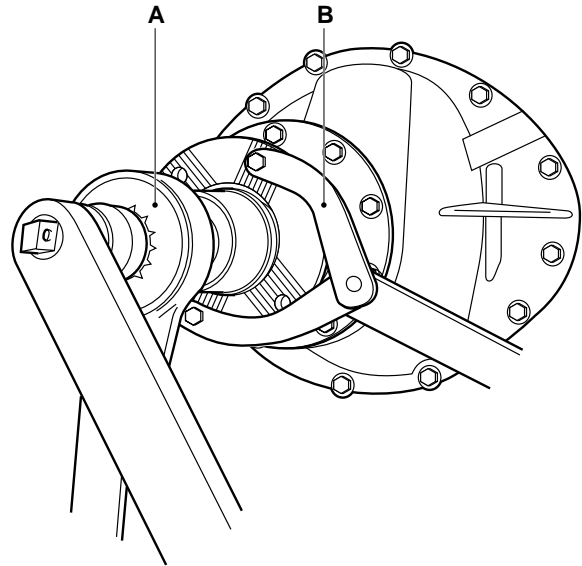

A8 00 386

4.6 REMOVAL AND INSTALLATION, PINION OIL SEAL

Removing pinion oil seal

1. Remove the drive flange.
2. Drill two holes into the oil seal and screw the special tool (B) (DAF No. 0484899) into the oil seal. Pull the oil seal from the pinion housing using the special tool (A) (DAF No. 0694928).

Installing pinion oil seal

1. Use the special tool (DAF No. 1310407) to fit the oil seal such that the marking "outside" is pointing outward.
2. Fit the drive flange.

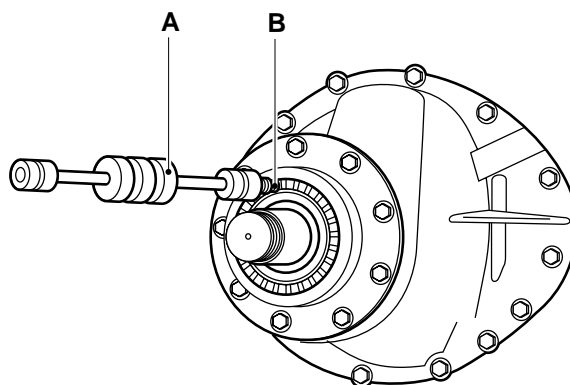

A8 00 381

4.7 REMOVAL AND INSTALLATION, DIFFERENTIAL

Removing differential

1. Drain the oil from the differential. See chapter "Draining and filling".
2. Remove the prop shaft from the drive flange.
3. Remove the stub axles.
4. Remove the air connection for the differential lock, if applicable.
5. Attach the differential securely to a lifting device.
6. Remove the attachment bolts and nuts from the differential.
7. Remove the differential from the axle housing using two thrust bolts.

Installing differential

1. Clean the mating surfaces of the axle housing and the differential housing. Regrind the mating faces lightly. Do not damage the mating faces in the process.
2. Clean and degrease the bolts. Check the bolts and stud bolts for signs of damage.
3. Apply a thin, even layer of sealant to the mating surface and around the bolt holes of the axle housing.
4. Apply locking compound to the attachment bolts. See main group "Technical data".
5. Fit the differential into the axle housing. Fit the attachment bolts and nuts and tighten them evenly. Tighten the attachment bolts and nuts to the specified tightening torque. See "Technical data".
6. Fit the air connection to the differential lock.
7. Fit the stub axles.
8. Fit the prop shaft to the drive flange.
9. Fill the differential with oil. See chapter "Draining and filling".

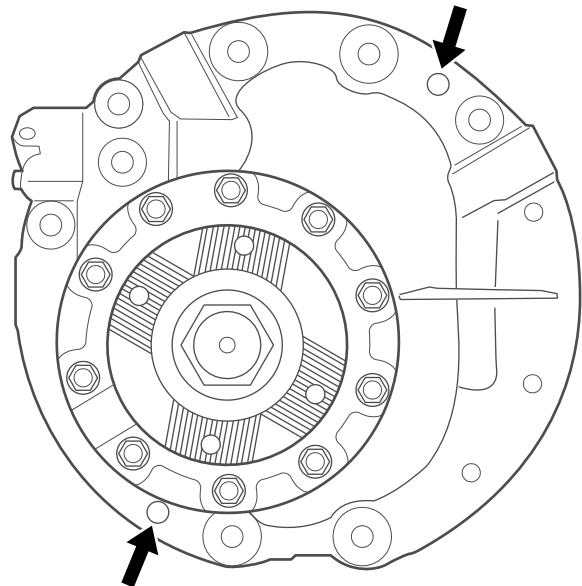

A8 00 378

4.8 REMOVAL AND INSTALLATION, DIFFERENTIAL LOCK

Removing differential lock

1. Remove the differential.



Do not come near the selector sleeve when de-aerating the differential lock.

2. Pressurise the air connection of the differential lock. Remove the special tool (A). Evenly de-aerate the differential lock.
3. Remove the attachment bolts (1) from the cylinder cover (2). Remove the cover.

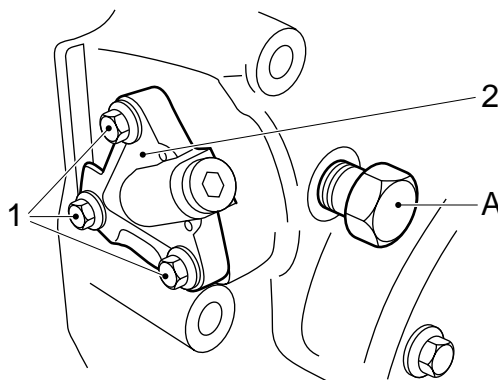

A8 00 395

4. Remove the piston (5).
5. Remove the shifting fork (2) and the selector sleeve (1) with the spring (3).

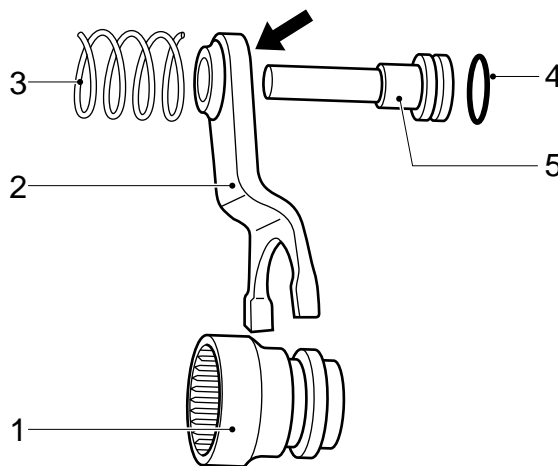

A8 00 383

Installing differential lock

1. Install the shifting fork (2) and selector sleeve (1) with the spring (3).

Note:

Make sure that the flat side (see arrow) of the shifting fork (2) points towards the piston (5).

2. Apply a small amount of oil to the seal (4) of the piston (5).
3. Install the piston (5).
4. Install the cylinder cover (2) and tighten the attachment bolts evenly. Tighten the attachment bolts (1) to the specified tightening torque. See main group "Technical data".



Do not come near the selector sleeve when de-aerating the differential lock.

5. Pressurise the air connection of the differential lock. Fit special tool (A) (DAF No. 1329447), so that the differential lock is blocked.
6. Install the differential.

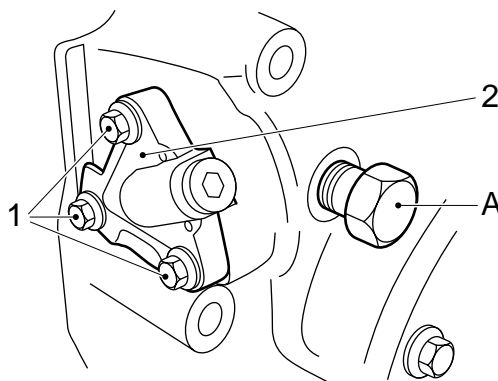

A8 00 395

5. DRAINING AND FILLING

5.1 DRAINING AND FILLING, DIFFERENTIAL



To prevent skin injury, avoid unnecessary contact with the drained oil.

Draining the differential

1. Position the vehicle on a level surface.
2. Place a suitable tray beneath the differential to collect the oil.
3. Remove the drain plug (1) and the level check/filler plug (2). Drain the oil.
4. Apply sealant to the screw thread of the drain plug (1). Install the drain plug (1) and tighten it to the specified tightening torque. See main group "Technical data".

Filling the differential

1. Fill the differential via the level check/filler plug (2) with the specified and correct quantity of oil. See main group "Technical data".
2. Check the oil level after 5 minutes; it should reach up to the level check/filler plug (2).
3. Apply sealant to the screw thread of the level check/filler plug (2). Fit the level check/filler plug (2).

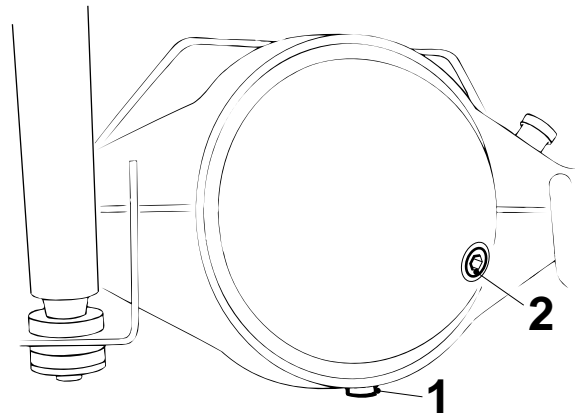

A8 00 370

CONTENTS

	Page	Date
1. SAFETY INSTRUCTIONS	1-1	200313
2. GENERAL	2-1	200313
2.1 Description of 10.26 axle	2-1	200313
2.2 Overview drawing, wheel hub	2-3	200313
3. INSPECTION AND ADJUSTMENT	3-1	200313
3.1 Inspecting differential oil level	3-1	200313
3.2 Checking operation of differential lock	3-1	200313
3.3 Inspection, wheel-speed sensor ring	3-2	200313
4. REMOVAL AND INSTALLATION	4-1	200313
4.1 Removal and installation, stub axles	4-1	200313
4.2 Removal and installation, wheel hub	4-2	200313
4.3 Removal and installation, compact bearing	4-5	200313
4.4 Removal and installation, wheel-speed sensor	4-6	200313
4.5 Removal and installation, drive flange	4-7	200313
4.6 Removal and installation, pinion oil seal	4-8	200313
4.7 Removal and installation, differential	4-9	200313
4.8 Removal and installation, differential lock	4-10	200313
5. DRAINING AND FILLING	5-1	200313
5.1 Draining and filling, differential	5-1	200313

1. SAFETY INSTRUCTIONS



Always use stands to support the chassis or components when working under the vehicle.

Always use the appropriate lifting gear or approved hoists to remove and install heavy components. Attach the component securely to the lifting or hoisting gear.

2. GENERAL

2.1 DESCRIPTION OF 10.26 AXLE

Differential

The 10.26 axle has a differential with hypoid gearing.

A single reduction is applied.

The bevelled gear-to-pinion backlash is achieved using adjusting nuts.

The pre-load of the pinion bearings is adjusted using shims which are placed between the bearing inner races.

The pinion housing can be removed using jacking bolts.

Differential lock

The 10.26 axle is equipped with a variable differential-gear lock.

The satellite gear housing flange is fitted with spline tothing on the right-hand side. The left-hand side of the selector sleeve is equipped with similar tothing.

The selector sleeve has internal splines similar to those on the stub axle.

There is a groove on outside of the selector sleeve accommodating a fork which is attached to the engaging cylinder.

If the engaging cylinder is pressurised using the pneumatic switch, the selector sleeve tothing will mesh with the tothing of the satellite gear housing.

If the engaging cylinder is vented via the pneumatic switch, the spring will ensure that the lock is disengaged.

Wheel hub

The wheel hub (3) has a compact bearing. The compact bearing and hub oil seal are a single unit. The compact bearing is retained on the rear side with a spring washer.

The thrust washer (2), which is located between the hub nut (1) and compact bearing, has a lip on the inside. This lip fits into a recess on the axle journal. This prevents the hub nut from loosening if any problems arise with the compact bearing. The hub nut is of the self-locking type. The nut is locked by bending the lips on the hub nut outward.

The compact bearing of the wheel hub is greased and is maintenance-free.

The correct wheel bearing pre-load is achieved by fitting the hub nut as specified. The stub axle and brake disc are attached to the wheel hub with bolts.

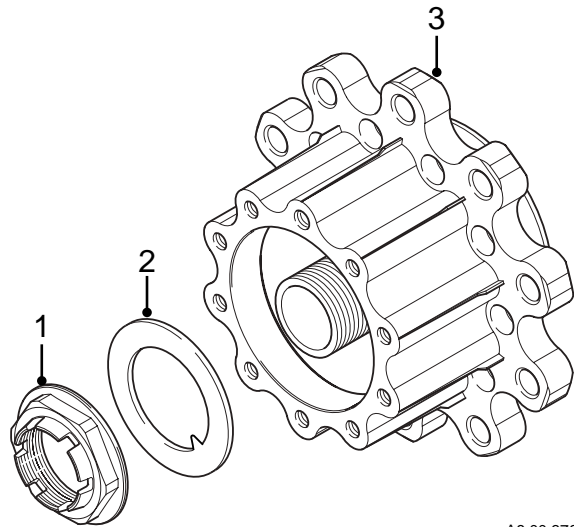

A8 00 376

2.2 OVERVIEW DRAWING, WHEEL HUB

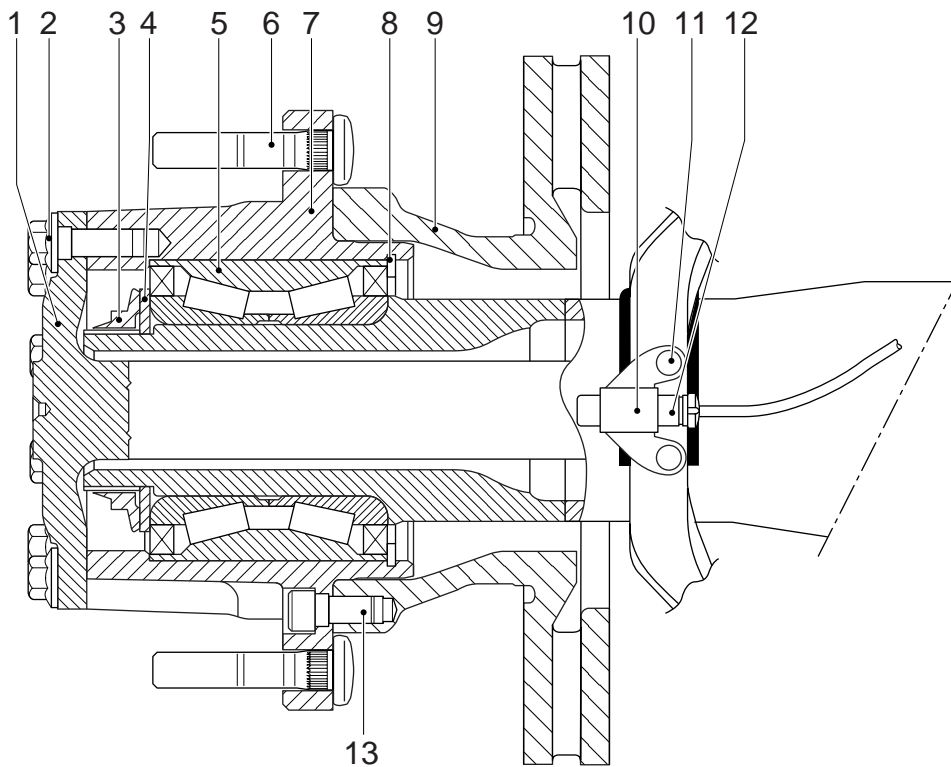

A8 00 374

Legend

1. Stub axle
2. Stub axle attachment bolt
3. Hub nut
4. Thrust washer
5. Compact bearing
6. Wheel stud
7. Wheel hub
8. Spring washer
9. Brake disc
10. Wheel-speed sensor holder
11. Wheel-speed sensor holder attachment bolts
12. Wheel-speed sensor
13. Brake disc attachment bolt

3. INSPECTION AND ADJUSTMENT

3.1 INSPECTING DIFFERENTIAL OIL LEVEL



To prevent skin injury, avoid unnecessary contact with the drained oil.

1. Position the vehicle on a level surface.
2. Remove the level check/filler plug (1). The oil level must reach the level check/filler opening (1).
3. Apply sealant to the plug. Secure the plug.

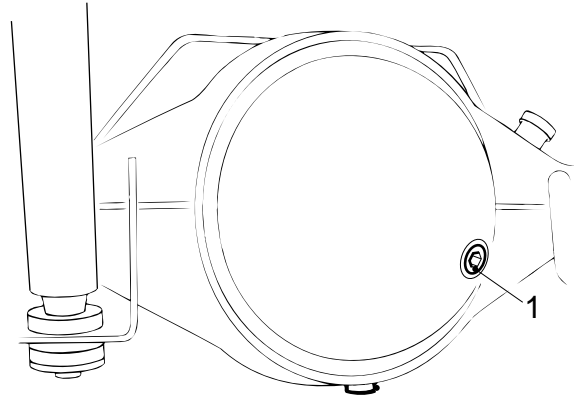

A8 00 375

3.2 CHECKING OPERATION OF DIFFERENTIAL LOCK

1. Jack up the rear axle and support it on stands.
2. Bring the air system to operating pressure.
3. Engage the differential lock. The warning indicator in the cab should now be activated.
4. Check whether there is a "rigid" connection between the driven wheels.
5. Disengage the differential lock. The warning indicator must no longer be activated and the "rigid" connection between the driven wheels should be interrupted.

3.3 INSPECTION, WHEEL-SPEED SENSOR RING

1. Remove the wheel hub.
2. Check the sensor ring (2) for deposits. Special attention should be paid to deposits between the teeth of the sensor ring. Clean the sensor ring if necessary.
3. Check the sensor ring (2) for damage. Even the slightest damage may cause a failure. If necessary, replace the wheel hub.
4. Check the sensor (1) for smooth operation. If necessary, clean the sensor (1) and re-apply the specified anti-corrosion agent. See main group "Technical data".

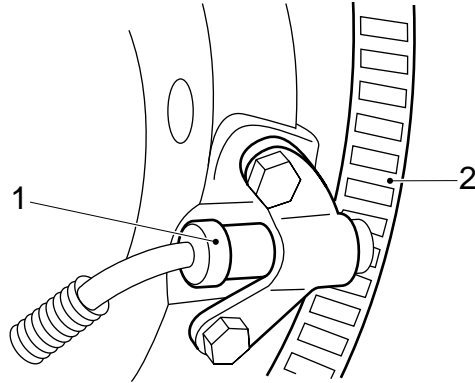

A8 00 379



Never tap the sensor with a hammer. This may damage both the sensor and the sensor ring.

5. Check the ABS system for proper operation.

4. REMOVAL AND INSTALLATION

4.1 REMOVAL AND INSTALLATION, STUB AXLES

Removing stub axles

1. Jack up the rear axle and support it on stands.
2. Engage the differential lock. Check that the axle is blocked. Replace the switch by the special tool (DAF No. 1329447), see (A). This is to prevent the selector sleeve from falling into the differential when removing the stub axle.

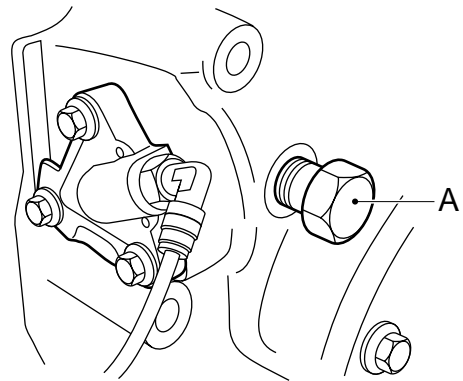

A8 00 396

3. Remove the stub axle attachment bolts.
4. Remove the stub axle using special tool (DAF No. 0694980), if required, see (B), or with a copper punch. When the stub axle comes loose, a small amount of oil may leak out. Collect this oil.

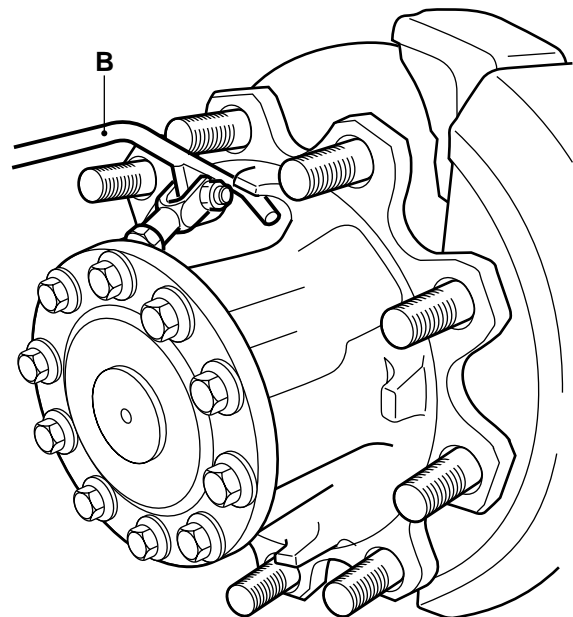

A8 00 382

Installing stub axles

1. Clean the mating surfaces of the stub axle flange and wheel hub.
2. Apply the specified sealant to the mating surface of the stub axle flange. See main group "Technical data".
3. Fit the stub axle. Tighten the stub axle attachment bolts to the specified tightening torque. See main group "Technical data".
4. Engage the differential lock and remove the special tool from the differential lock. Install the switch.

4.2 REMOVAL AND INSTALLATION, WHEEL HUB

Removing wheel hub

1. Jack up the rear axle and support it on stands.
2. Remove the wheels.
3. Remove the brake caliper.
4. Remove the stub axle.
5. Remove the hub nut (1) using special tool (A) (DAF No. 0535266) and a torque amplifier (B).
6. Remove the thrust washer (2).

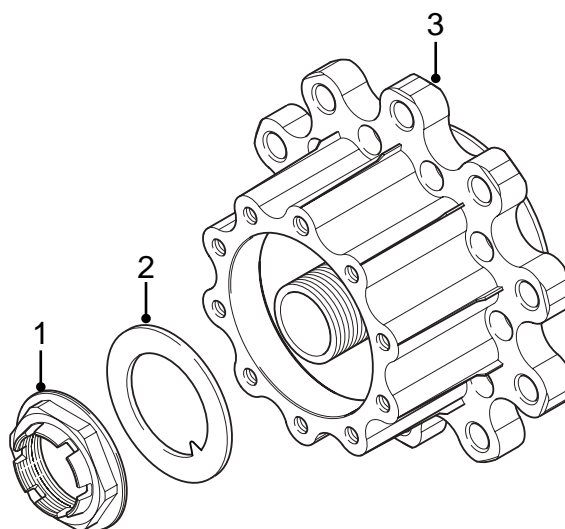

A8 00 376

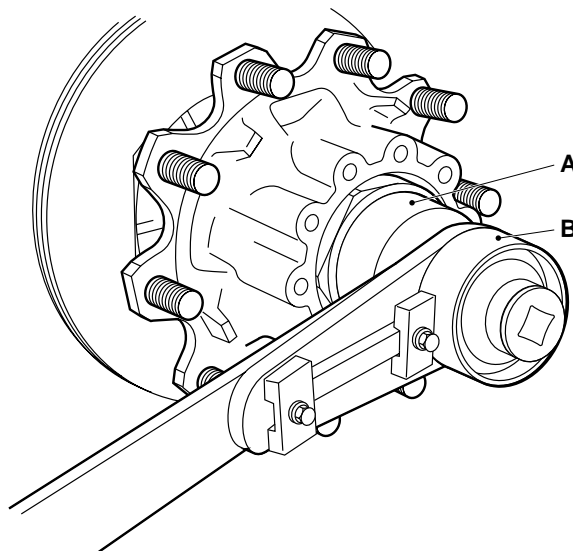

A8 00 355

7. Install the guide sleeve (A), special tool (DAF No. 1329490), on the axle journal.
8. Attach the wheel hub securely to a movable lifting device.
9. Slide the wheel hub from the axle journal using the lifting device.
Take care that the wheel hub does not rest on the guide sleeve (A) as the latter is not strong enough to take the weight of the wheel hub.

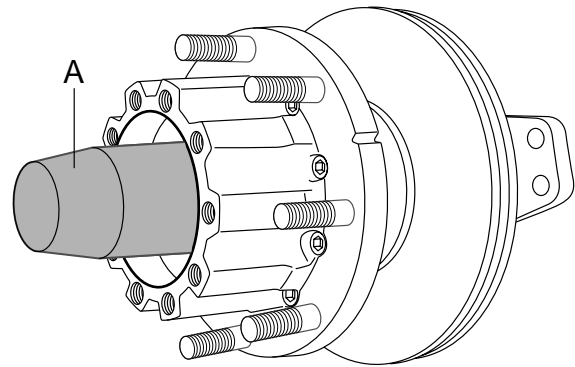

A8 00 389

Installing wheel hub

1. Check the wheel-speed sensor ring and the oil seals in the wheel hub for damage.
2. Check the axle journal screw thread carefully for damage.



You must never fit a wheel hub on an axle journal with damaged screw thread.

3. Apply a thin and even layer of the specified anti-corrosion agent to the axle journal. See main group "Technical data".

Note:

Do not apply too much anti-corrosion agent to the axle journal. When installing the wheel hub, the excess anti-corrosion agent will collect at the backside of the wheel hub. When the vehicle is used in daily operation, this anti-corrosion agent can leak out so that it looks as if the oil seal leaks.

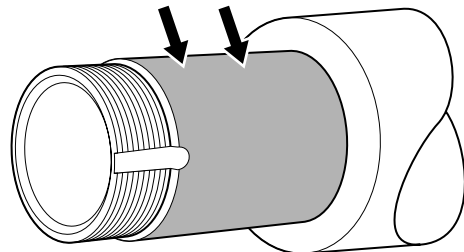

A8 00 390

4. Install the guide sleeve (A), special tool (DAF No. 1329490), on the axle journal.
5. Attach the wheel hub securely to a movable lifting device.
6. Position the wheel hub exactly in front of the axle journal using the movable lifting device. Slide the wheel hub onto the axle journal.
Take care that the wheel hub does not rest on the guide sleeve (A) as the latter is not strong enough to take the weight of the wheel hub.

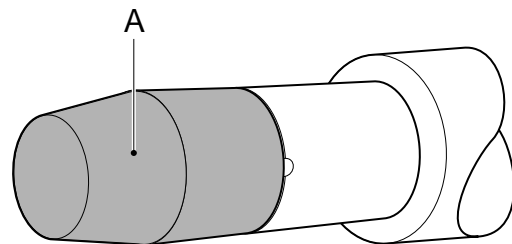

A8 00 397

7. Fit the thrust washer (2).
8. Replace the hub nut (1). Apply a few drops of oil to the abutting surface of the hub nut. Fit the hub nut.

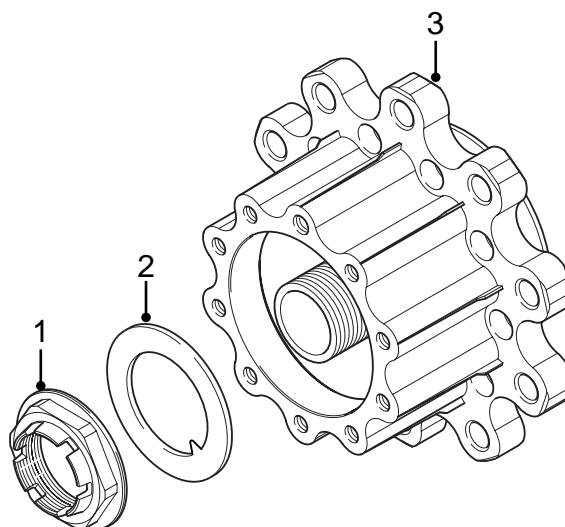

A8 00 376

9. Tighten the hub nut in the specified manner. See main group "Technical data". Use special tool (A) (DAF No. 0535266) and a torque amplifier (B) to do so.

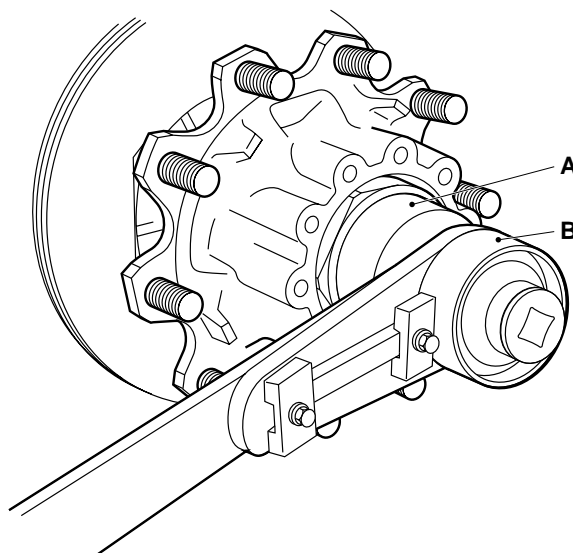

A8 00 355

10. Press the wheel-speed sensor (1) against the sensor ring (2).
When the vehicle is being driven, the air gap between the sensor and the sensor ring is adjusted automatically.
If the sensor is stuck, remove, clean and refit it.



Never tap the sensor with a hammer. This may damage both the sensor and the sensor ring.

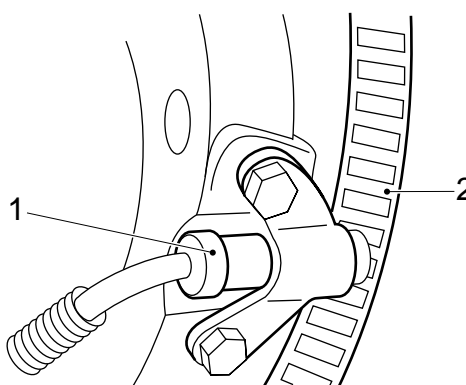

A8 00 379

11. Fit the stub axle.
12. Fit the brake caliper.
13. Put the wheels back on.
14. Check the ABS system for proper operation.

4.3 REMOVAL AND INSTALLATION, COMPACT BEARING

Removing compact bearing

1. Remove the wheel hub (1).
2. Remove the spring washer (3).
3. Remove the compact bearing (2) from the wheel hub using a press.

Installing compact bearing

1. Fit the compact bearing (2) to the wheel hub (1) using a press.
2. Fit the spring washer (3).
3. Install the wheel hub.

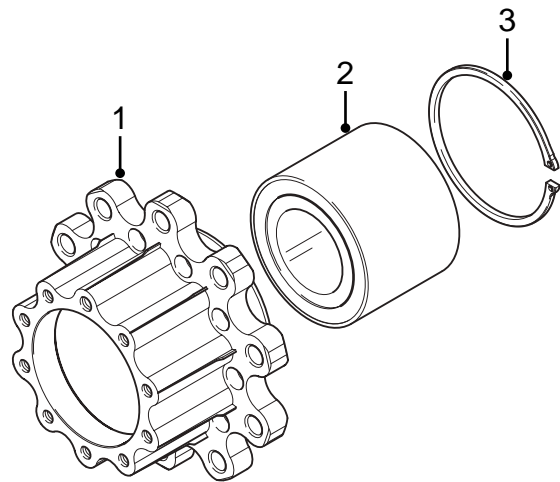

A8 00 377

4.4 REMOVAL AND INSTALLATION, WHEEL-SPEED SENSOR

Removing the wheel-speed sensor

1. Remove the wheel-speed sensor (1) from the holder (3).
2. Cut the clamping strips attaching the cable.
3. Unplug the connector and remove the wheel-speed sensor.

Installing the wheel-speed sensor

1. Clean the wheel-speed sensor (1) and the clamping sleeve (2). If necessary, replace the clamping sleeve (2).
2. Apply the specified anti-corrosion agent to the circumference of the wheel-speed sensor (1). See main group "Technical data".
3. Fit the wheel-speed sensor (1) in the holder (3). Press it against the sensor ring manually.
While the vehicle is being driven, the air gap between the sensor and the sensor ring is adjusted automatically.

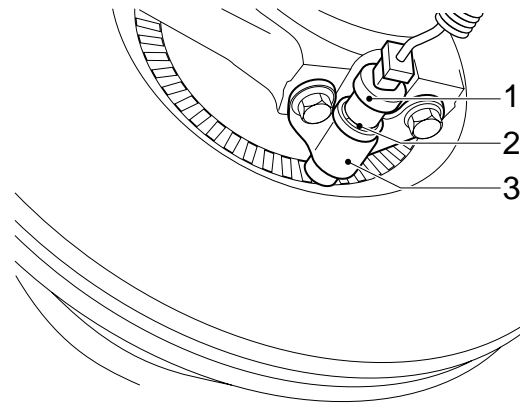

A8 00 435



Never tap the sensor with a hammer. This may damage both the sensor and the sensor ring.

4. Fit the connector and secure the cable with clamping strips.
5. Check the ABS system for proper operation.

4.5 REMOVAL AND INSTALLATION, DRIVE FLANGE

Removing drive flange

1. Remove the prop shaft from the drive flange.
2. Fit the special tool (B) (DAF No. 0484977) on the drive flange to prevent it from turning. Remove the drive flange nut using a torque amplifier (A).
3. Remove the drive flange. If necessary, use a puller.

Installing drive flange

1. Before installation check the drive flange along the oil seal running surface for grooves and/or sharp edges. If required, replace the drive flange.
2. Fit the drive flange.
3. Apply a small amount of oil to the abutting surface of the drive flange nut.
4. Apply locking compound to the screw thread. See main group "Technical data".
5. Fit the special tool (B) (DAF No. 0484977) on the drive flange to prevent it from turning. Fit the drive flange nut. Use a torque amplifier (A) to tighten the drive flange nut to the specified tightening torque. See main group "Technical data".
6. Fit the prop shaft to the drive flange.

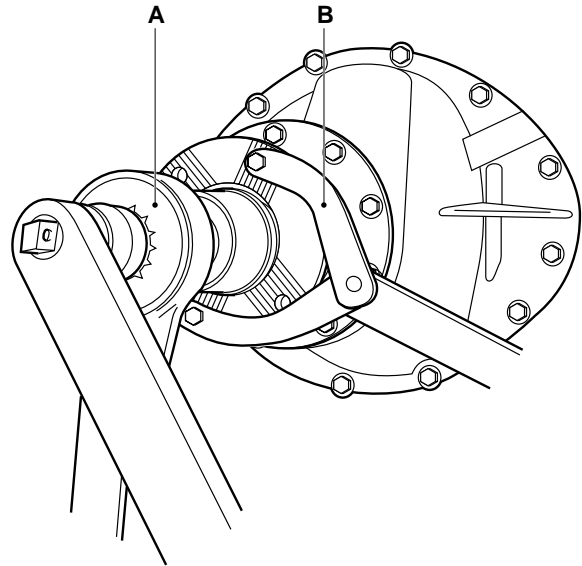

A8 00 386

4.6 REMOVAL AND INSTALLATION, PINION OIL SEAL

Removing pinion oil seal

1. Remove the drive flange.
2. Drill two holes into the oil seal and screw the special tool (B) (DAF No. 0484899) into the oil seal. Pull the oil seal from the pinion housing using the special tool (A) (DAF No. 0694928).

Installing pinion oil seal

1. Use the special tool (DAF No. 1310446) to fit the oil seal such that the marking "outside" is pointing outward.
2. Fit the drive flange.

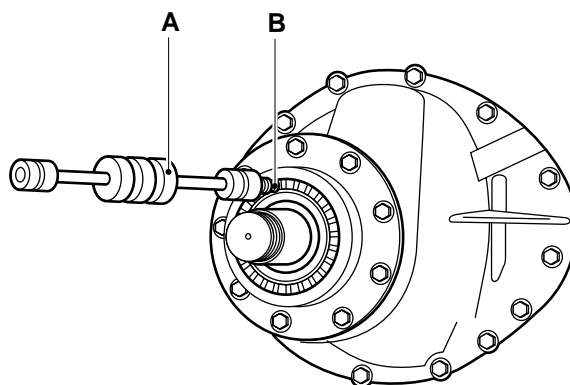

A8 00 381

4.7 REMOVAL AND INSTALLATION, DIFFERENTIAL

Removing differential

1. Drain the oil from the differential. See chapter "Draining and filling".
2. Remove the prop shaft from the drive flange.
3. Remove the stub axles.
4. Remove the air connection for the differential lock, if applicable.
5. Attach the differential securely to a lifting device.
6. Remove the attachment bolts and nuts from the differential.
7. Remove the differential from the axle housing using two thrust bolts.

Installing differential

1. Clean the mating surfaces of the axle housing and the differential housing. Regrind the mating faces lightly. Do not damage the mating faces in the process.
2. Clean and degrease the bolts. Check the bolts and stud bolts for signs of damage.
3. Apply a thin, even layer of sealant to the mating surface and around the bolt holes of the axle housing.
4. Apply locking compound to the attachment bolts. See main group "Technical data".
5. Fit the differential into the axle housing. Fit the attachment bolts and nuts and tighten them evenly. Tighten the attachment bolts and nuts to the specified tightening torque. See "Technical data".
6. Fit the air connection to the differential lock.
7. Fit the stub axles.
8. Fit the prop shaft to the drive flange.
9. Fill the differential with oil. See chapter "Draining and filling".

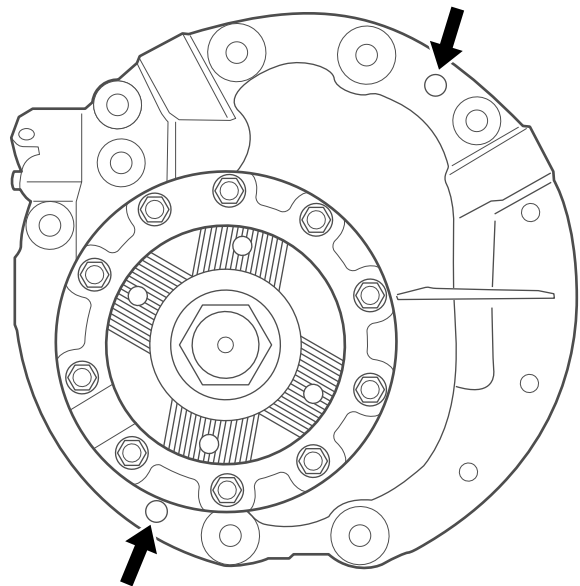

A8 00 378

4.8 REMOVAL AND INSTALLATION, DIFFERENTIAL LOCK

Removing differential lock

1. Remove the differential.



Do not come near the selector sleeve when de-aerating the differential lock.

2. Pressurise the air connection of the differential lock. Remove the special tool (A). Evenly de-aerate the differential lock.
3. Remove the attachment bolts (1) from the cylinder cover (2). Remove the cover.

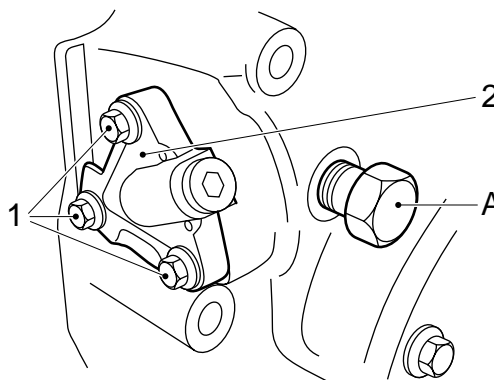

A8 00 395

4. Remove the piston (5).
5. Remove the shifting fork (2) and the selector sleeve (1) with the spring (3).

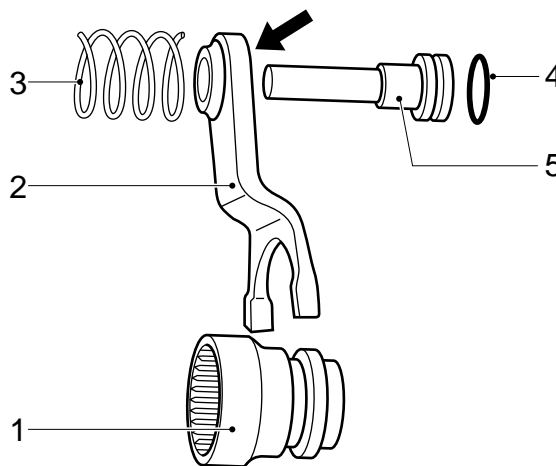

A8 00 383

Installing differential lock

1. Install the shifting fork (2) and selector sleeve (1) with the spring (3).

Note:

Make sure that the flat side (see arrow) of the shifting fork (2) points towards the piston (5).

2. Apply a small amount of oil to the seal (4) of the piston (5).
3. Install the piston (5).
4. Install the cylinder cover (2) and tighten the attachment bolts evenly. Tighten the attachment bolts (1) to the specified tightening torque. See main group "Technical data".



Do not come near the selector sleeve when de-aerating the differential lock.

5. Pressurise the air connection of the differential lock. Fit special tool (A) (DAF No. 1329447), so that the differential lock is blocked.
6. Install the differential.

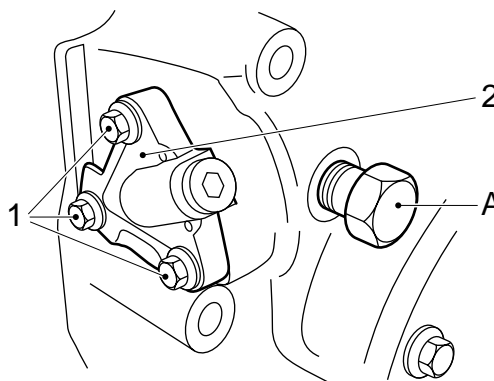

A8 00 395

5. DRAINING AND FILLING

5.1 DRAINING AND FILLING, DIFFERENTIAL



To prevent skin injury, avoid unnecessary contact with the drained oil.

Draining the differential

1. Position the vehicle on a level surface.
2. Place a suitable tray beneath the differential to collect the oil.
3. Remove the drain plug (1) and the level check/filler plug (2). Drain the oil.
4. Apply sealant to the screw thread of the drain plug (1). Install the drain plug (1) and tighten it to the specified tightening torque. See main group "Technical data".

Filling the differential

1. Fill the differential via the level check/filler plug (2) with the specified and correct quantity of oil. See main group "Technical data".
2. Check the oil level after 5 minutes; it should reach up to the level check/filler plug (2).
3. Apply sealant to the screw thread of the level check/filler plug (2). Fit the level check/filler plug (2).

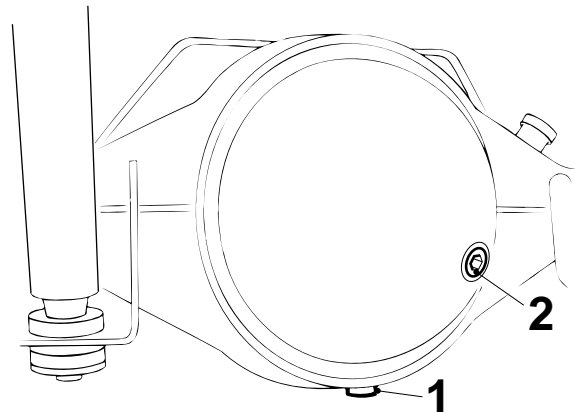

A8 00 370

CONTENTS

	Page	Date
1. SAFETY INSTRUCTIONS	1-1	200313
2. GENERAL	2-1	200313
2.1 Description of 11.26 axle	2-1	200313
2.2 Overview drawing, wheel hub unit	2-3	200313
3. INSPECTION AND ADJUSTMENT	3-1	200313
3.1 Inspecting differential oil level	3-1	200313
3.2 Checking operation of differential lock	3-1	200313
3.3 Inspection, wheel-speed sensor ring	3-2	200313
4. REMOVAL AND INSTALLATION	4-1	200313
4.1 Removal and installation, stub axles	4-1	200313
4.2 Removal and installation, wheel hub unit	4-2	200313
4.3 Removal and installation, wheel-speed sensor ring	4-6	200313
4.4 Removal and installation, wheel-speed sensor	4-7	200313
4.5 Removal and installation, drive flange	4-8	200313
4.6 Removal and installation, pinion oil seal	4-9	200313
4.7 Removal and installation, differential	4-10	200313
4.8 Removal and installation, differential lock	4-11	200313
5. DRAINING AND FILLING	5-1	200313
5.1 Draining and filling, differential	5-1	200313

1. SAFETY INSTRUCTIONS



Always use stands to support the chassis or components when working under the vehicle.

Always use the appropriate lifting gear or approved hoists to remove and install heavy components. Attach the component securely to the lifting or hoisting gear.

2. GENERAL

2.1 DESCRIPTION OF 11.26 AXLE

Differential

The 11.26 axle has a differential with hypoid gearing.

A single reduction is applied.

The bevelled gear-to-pinion backlash is achieved using adjusting nuts.

The pre-load of the pinion bearings is adjusted using shims which are placed between the bearing inner races.

The pinion housing can be removed using jacking bolts.

Differential lock

The 11.26 axle is equipped with a variable differential-gear lock.

The satellite gear housing flange is fitted with spline tothing on the right-hand side. The left-hand side of the selector sleeve is equipped with similar tothing.

The selector sleeve has internal splines similar to those on the stub axle.

There is a groove on outside of the selector sleeve accommodating a fork which is attached to the engaging cylinder.

If the engaging cylinder is pressurised using the pneumatic switch, the selector sleeve tothing will mesh with the tothing of the satellite gear housing.

If the engaging cylinder is vented via the pneumatic switch, the spring will ensure that the lock is disengaged.

Wheel hub unit

The wheel hub has a compact bearing. The compact bearing and hub oil seal are integrated into a single unit with the wheel hub. This is called the wheel hub unit (3).

The thrust washer (2) installed between the hub nut (1) and wheel bearings, is fitted with two straight surfaces on the inside to prevent the washer from turning. This is to prevent the hub nut (1) from loosening in case of wheel bearing problems. The hub nut (1) is of the self-locking type. The nut is locked by bending the lips on the hub nut outward.

The wheel bearings of the wheel hub unit are greased and are maintenance free.

The correct wheel bearing pre-load is achieved by fitting the hub nut as specified. The stub axle and brake disc are attached to the wheel hub with bolts.

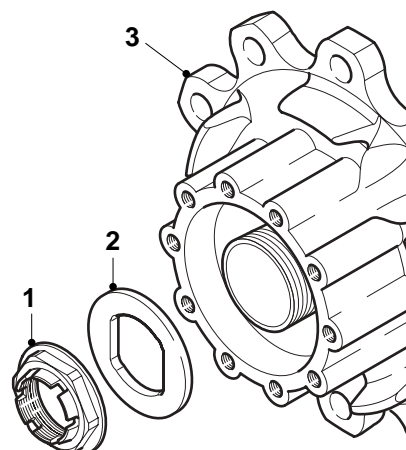

A8 00 356

2.2 OVERVIEW DRAWING, WHEEL HUB UNIT

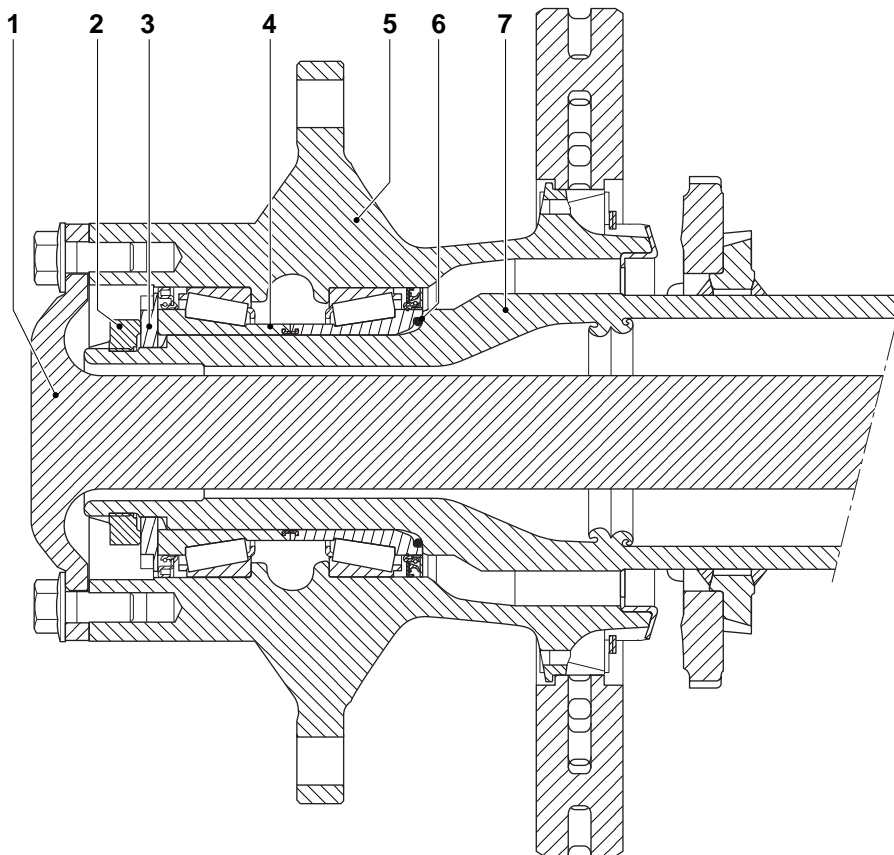

A8 00 341

Legend

1. Stub axle
2. Hub nut
3. Thrust washer
4. Compact bearing
5. Hub
6. O-ring
7. Axle journal

3. INSPECTION AND ADJUSTMENT

3.1 INSPECTING DIFFERENTIAL OIL LEVEL



To prevent skin injury, avoid unnecessary contact with the drained oil.

1. Position the vehicle on a level surface.
2. Remove the level check/filler plug (1). The oil level must reach the level check/filler opening (1).
3. Apply sealant to the plug. Secure the plug.

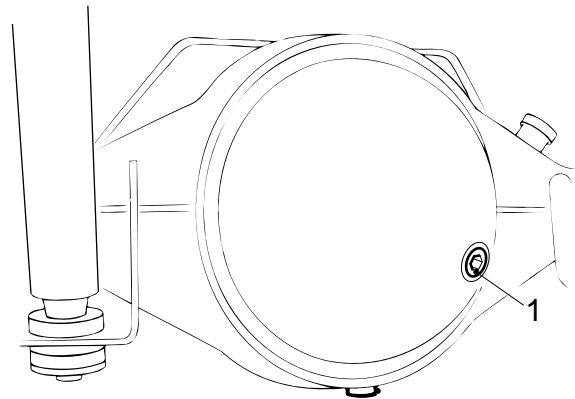

A8 00 375

3.2 CHECKING OPERATION OF DIFFERENTIAL LOCK

1. Jack up the rear axle and support it on stands.
2. Bring the air system to operating pressure.
3. Engage the differential lock. The warning indicator in the cab should now be activated.
4. Check whether there is a "rigid" connection between the driven wheels.
5. Disengage the differential lock. The warning indicator must no longer be activated and the "rigid" connection between the driven wheels should be interrupted.

3.3 INSPECTION, WHEEL-SPEED SENSOR RING

1. Remove the wheel hub unit.
2. Check the sensor ring (2) for deposits. Special attention should be paid to deposits between the teeth of the sensor ring. Clean the sensor ring if necessary.
3. Check the sensor ring (2) for damage. Even the slightest damage may cause a failure. Replace the sensor ring if necessary.
4. If possible, the sensor ring (2) should be checked for the maximum admissible axial end play. See "Technical data".
5. Check the sensor (1) for smooth operation. If necessary, clean the sensor (1) and re-apply the specified anti-corrosion agent. See main group "Technical data".



Never tap the sensor with a hammer. This may damage both the sensor and the sensor ring.

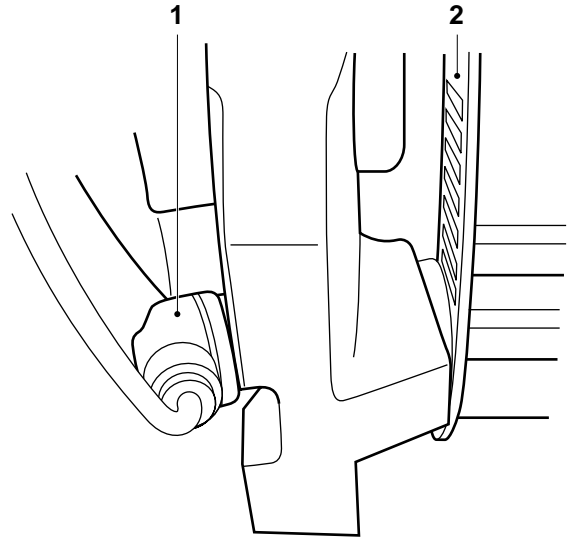

A8 00 342

6. Check the ABS system for proper operation.

4. REMOVAL AND INSTALLATION

4.1 REMOVAL AND INSTALLATION, STUB AXLES

Removing stub axles

1. Jack up the rear axle and support it on stands.
2. Engage the differential lock. Check that the axle is blocked. Replace the switch by the special tool (DAF No. 1329447), see (A). This is to prevent the selector sleeve from falling into the differential when removing the stub axle.

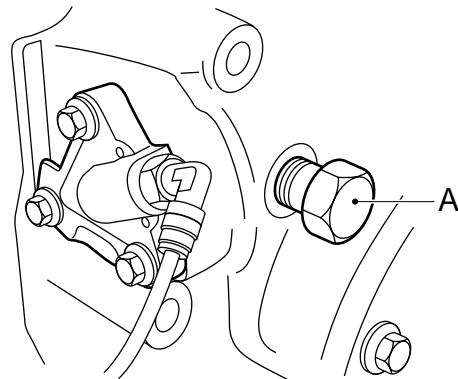

A8 00 396

3. Remove the stub axle attachment bolts.
4. Remove the stub axle using special tool (DAF No. 0694980), if required, see (B). When the stub axle comes loose, a small amount of oil may leak out. Collect this oil.

Installing stub axles

1. Clean the mating surfaces of the stub axle flange and wheel hub unit.
2. Apply the specified sealant to the mating surface of the stub axle flange. See main group "Technical data".
3. Fit the stub axle. Tighten the stub axle attachment bolts to the specified tightening torque. See main group "Technical data".
4. Engage the differential lock and remove the special tool from the differential lock. Install the switch.

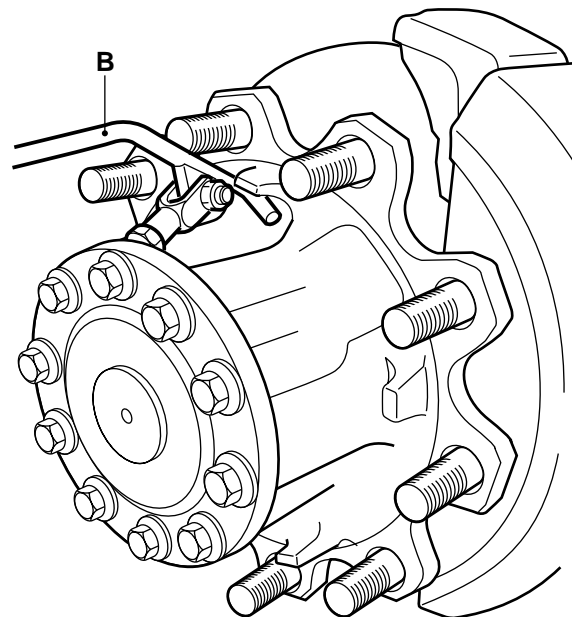

A8 00 382

4.2 REMOVAL AND INSTALLATION, WHEEL HUB UNIT

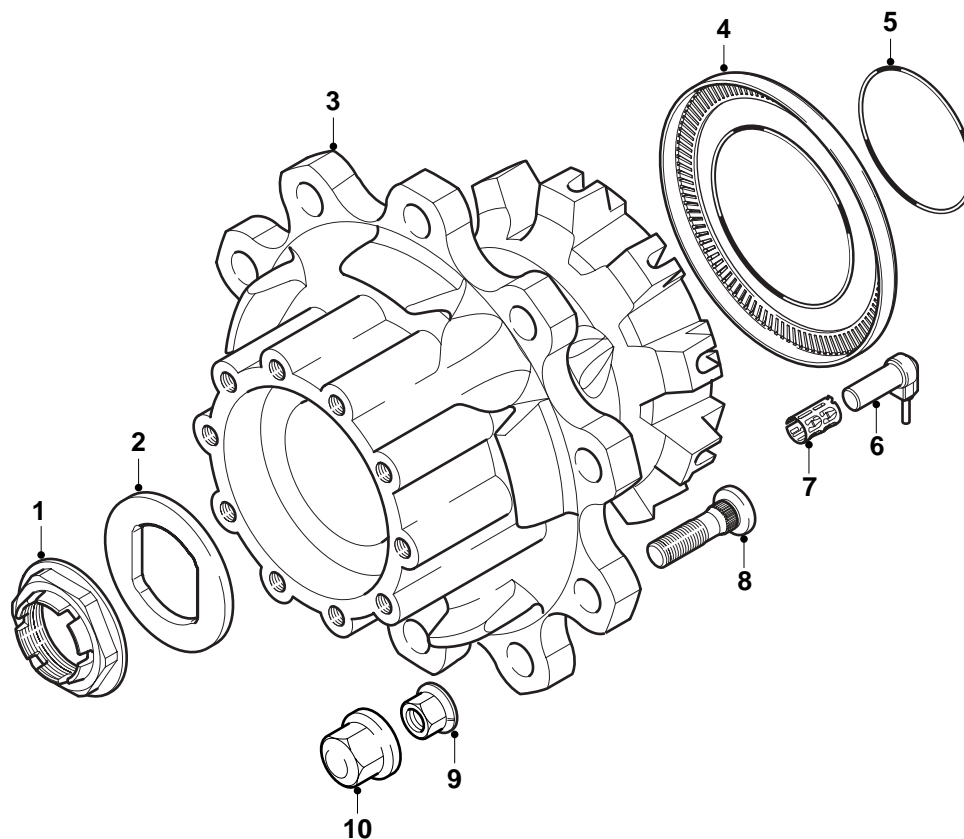

A8 00 348

8

Removing the wheel hub unit

1. Jack up the rear axle and support it on stands.
2. Remove the wheels.
3. Remove the brake caliper.
4. Remove the stub axle.
5. Remove the hub nut (1) using the hub nut wrench (A), which is part of the special tool set (DAF No. 1329496). Loosen the hub nut (1), using a torque amplifier to do so.
6. Remove the thrust washer (2).

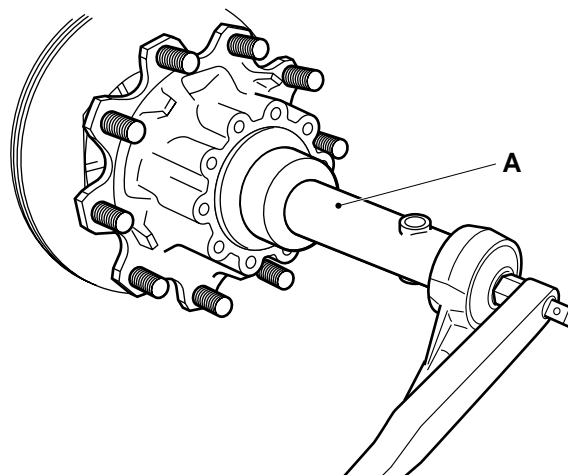

A8 00 405

7. Install the guide sleeve (A), which is part of the special tool set (DAF No. 1329496), on the axle journal.
8. Attach the wheel hub unit (3) securely to a movable lifting device.
9. Slide the wheel hub unit (3) from the axle journal using the lifting device.
Take care that the wheel hub unit (3) does not rest on the guide bush (A) as the latter is not strong enough to take the weight of the wheel hub unit (3).

Installing the wheel hub unit

1. Check the wheel-speed sensor ring and the seals in the wheel hub unit (3) for damage.
2. Check the axle journal screw thread carefully for damage.



You must never fit a wheel hub unit on an axle journal with damaged screw thread.

3. Install the O-ring (5) in the wheel hub unit.

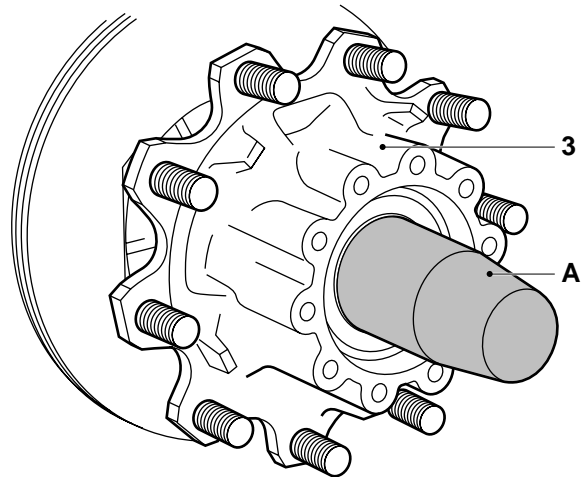

A8 00 345

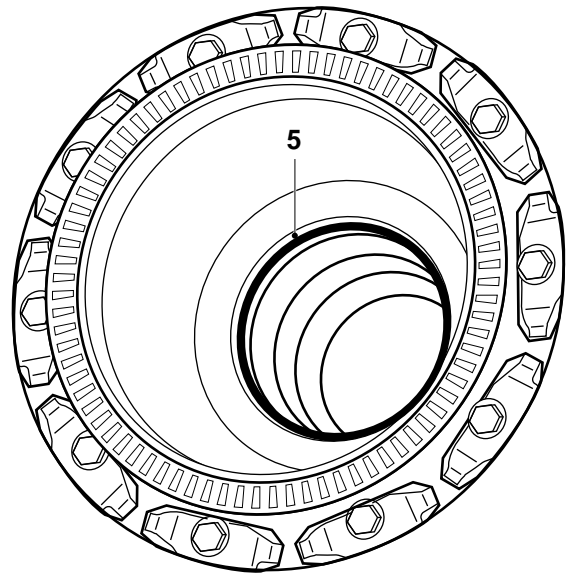

A8 00 350

4. Apply a thin and even layer of the specified anti-corrosion agent to the axle journal. See main group "Technical data".

Note:

Do not apply too much anti-corrosion agent to the axle journal. When installing the wheel hub unit, the excess anti-corrosion agent will collect at the backside of the wheel hub. When the vehicle is used in daily operation, this anti-corrosion agent can leak out so that it looks as if the oil seal leaks.

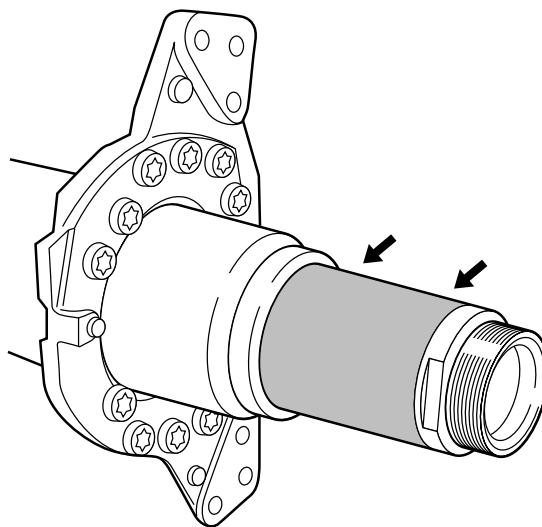

A8 00 344

5. Install the guide sleeve (A), which is part of the special tool set (DAF No. 1329496), on the axle journal.

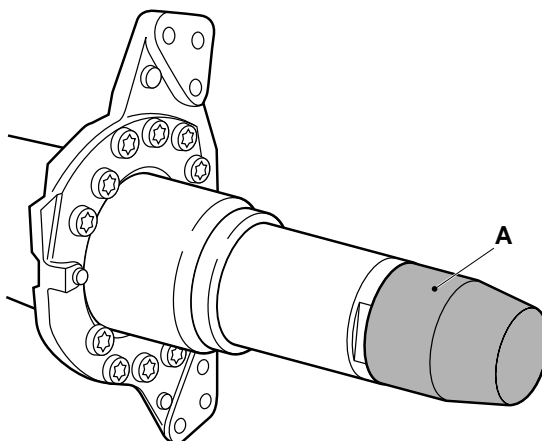

A8 00 343

6. Check that the spring clip, located between the inner bearing races, is positioned correctly.

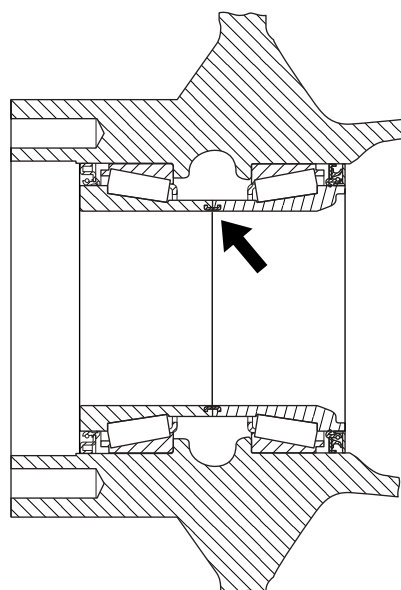

A8 00 434

7. Attach the wheel hub unit (3) securely to a movable lifting device.
8. Position the wheel hub unit (3) exactly in front of the axle journal using the movable lifting device. Slide the wheel hub unit (3) on the axle journal. Take care that the wheel hub unit (3) does not rest on the guide bush as the latter is not strong enough to take the weight of the wheel hub unit (3).
9. Fit the thrust washer (2).
10. Replace the hub nut (1). Apply a few drops of oil to the abutting surface of the hub nut (1). Fit the hub nut (1).
11. Tighten the hub nut (1) using the hub nut wrench (A), which is part of the special tool set (DAF No. 1329496). Tighten the hub nut (1) in the specified manner using a torque amplifier. See main group "Technical data".

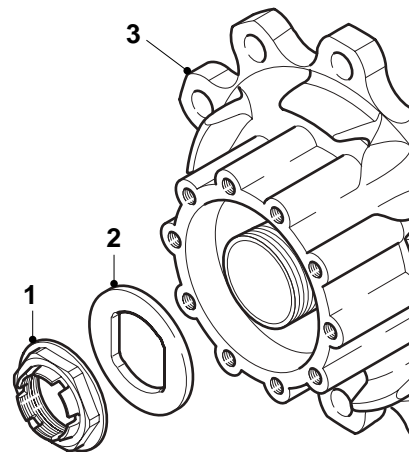

A8 00 356

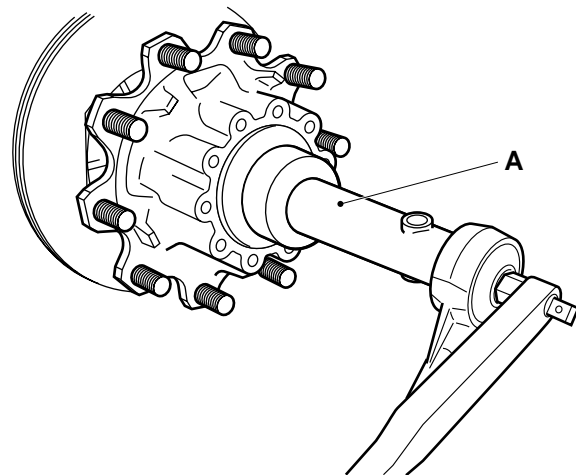

A8 00 405

12. Press the wheel-speed sensor (1) against the sensor ring (2). When the vehicle is being driven, the air gap between the sensor and the sensor ring is adjusted automatically. If the sensor is stuck, remove, clean and refit it.



Never tap the sensor with a hammer. This may damage both the sensor and the sensor ring.

13. Fit the stub axle.
14. Fit the brake caliper.
15. Put the wheels back on.
16. Check the ABS system for proper operation.

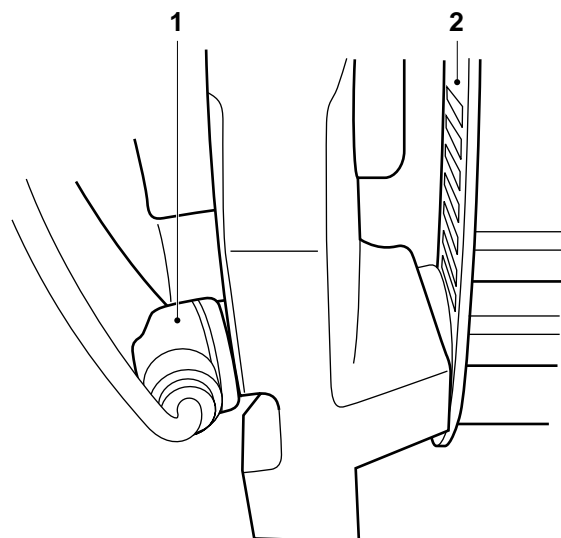

A8 00 342

4.3 REMOVAL AND INSTALLATION, WHEEL-SPEED SENSOR RING

Removing the wheel-speed sensor ring

1. Remove the wheel hub unit from the axle journal.
2. Use a driving tool to carefully tap the sensor ring from the inside from the wheel hub unit. Make sure that the wheel hub unit is not damaged in the process.



Once removed, a sensor ring should not be reused.

Installing the wheel-speed sensor ring

1. Check the mating surface of sensor ring and wheel hub unit for damage.
2. Check the new sensor ring carefully for possible damage in transit.
3. Use a flat plate and a press to fit the sensor ring to the wheel hub unit. Press the sensor ring evenly on the wheel hub unit until it fully abuts.
4. Fit the wheel hub unit on the axle journal.

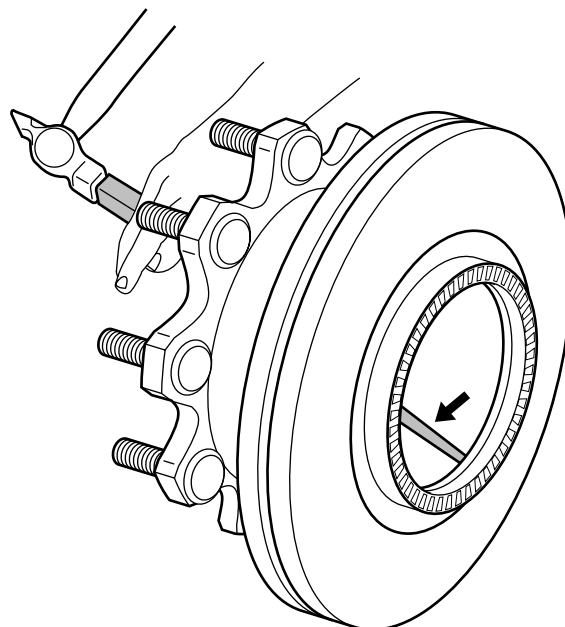

A8 00 359

5. Press the wheel-speed sensor (1) against the sensor ring (2). While the vehicle is being driven, the air gap between the sensor and the sensor ring is adjusted automatically.



Never tap the sensor with a hammer. This may damage both the sensor and the sensor ring.

6. Check the ABS system for proper operation.

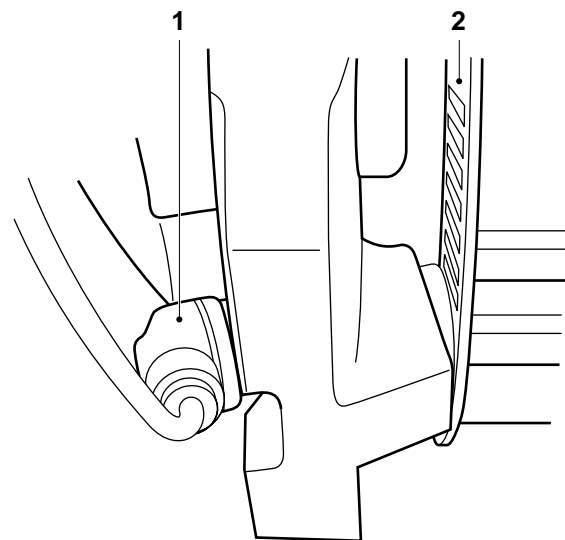

A8 00 342

4.4 REMOVAL AND INSTALLATION, WHEEL-SPEED SENSOR

Removing the wheel-speed sensor

1. Remove the wheel speed sensor (2).

Installing the wheel-speed sensor

1. Clean the wheel-speed sensor (2) and its holder (1). If necessary, replace the holder sleeve (1).
2. Apply anti-corrosion agent to the circumference of the wheel-speed sensor (2). See main group "Technical data".

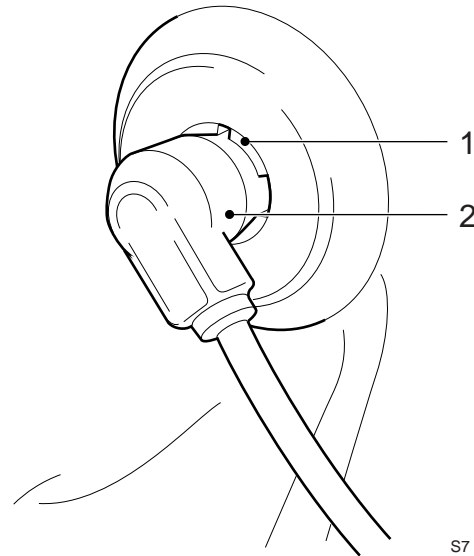

S7 00 796

3. Fit the wheel-speed sensor (1). Press it against the sensor ring (2) manually. While the vehicle is being driven, the air gap between the sensor and the sensor ring is adjusted automatically.



Never tap the sensor with a hammer. This may damage both the sensor and the sensor ring.

4. Check the ABS system for proper operation.

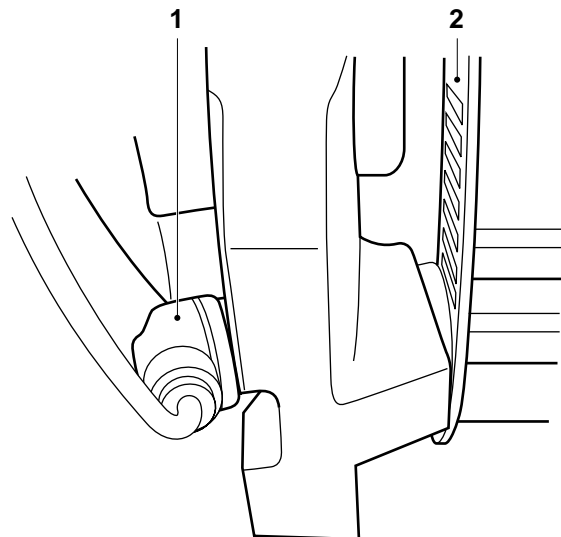

A8 00 342

4.5 REMOVAL AND INSTALLATION, DRIVE FLANGE**Removing drive flange**

1. Remove the prop shaft from the drive flange.
2. Fit the special tool (B) (DAF No. 0484977) on the drive flange to prevent it from turning. Remove the drive flange nut using a torque amplifier (A).
3. Remove the drive flange. If necessary, use a puller.

Installing drive flange

1. Before installation check the drive flange along the oil seal running surface for grooves and/or sharp edges. If required, replace the drive flange.
2. Fit the drive flange.
3. Apply a small amount of oil to the abutting surface of the drive flange nut.
4. Apply locking compound to the screw thread. See main group "Technical data".
5. Fit the special tool (B) (DAF No. 0484977) on the drive flange to prevent it from turning. Fit the drive flange nut. Use a torque amplifier (A) to tighten the drive flange nut to the specified tightening torque. See main group "Technical data".
6. Fit the prop shaft to the drive flange.

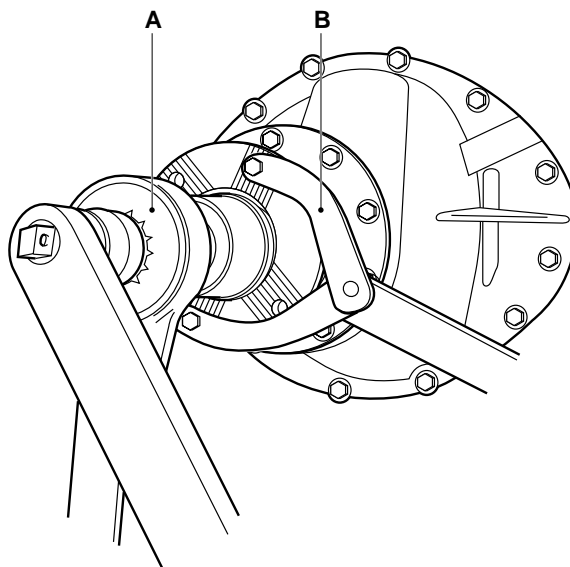

A8 00 386

4.6 REMOVAL AND INSTALLATION, PINION OIL SEAL

Removing pinion oil seal

1. Remove the drive flange.
2. Drill two holes into the oil seal and screw the special tool (B) (DAF No. 0484899) into the oil seal. Pull the oil seal from the pinion housing using the special tool (A) (DAF No. 0694928).

Installing pinion oil seal

1. Use the special tool (DAF No. 1310446) to fit the oil seal such that the marking "outside" is pointing outward.
2. Fit the drive flange.

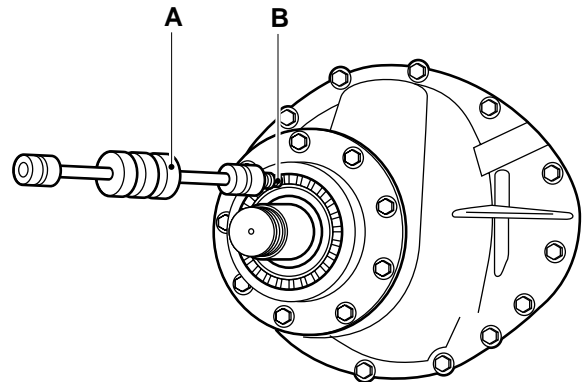

A8 00 381

4.7 REMOVAL AND INSTALLATION, DIFFERENTIAL**Removing differential**

1. Drain the oil from the differential. See chapter "Draining and filling".
2. Remove the prop shaft from the drive flange.
3. Remove the stub axles.
4. Remove the air connection for the differential lock, if applicable.
5. Attach the differential securely to a lifting device.
6. Remove the attachment bolts and nuts from the differential.
7. Remove the differential from the axle housing using two thrust bolts.

Installing differential

1. Clean the mating surfaces of the axle housing and the differential housing. Regrind the mating surfaces lightly. Do not damage the mating surfaces in the process.
2. Clean and degrease the bolts. Check the bolts and stud bolts for signs of damage.
3. Apply a thin, even layer of sealant to the mating surface and around the bolt holes of the axle housing.
4. Apply locking compound to the attachment bolts. See main group "Technical data".
5. Fit the differential into the axle housing. Fit the attachment bolts and nuts and tighten them evenly. Tighten the attachment bolts and nuts to the specified tightening torque. See "Technical data".
6. Fit the air connection to the differential lock.
7. Fit the stub axles.
8. Fit the prop shaft to the drive flange.
9. Fill the differential with oil. See chapter "Draining and filling".

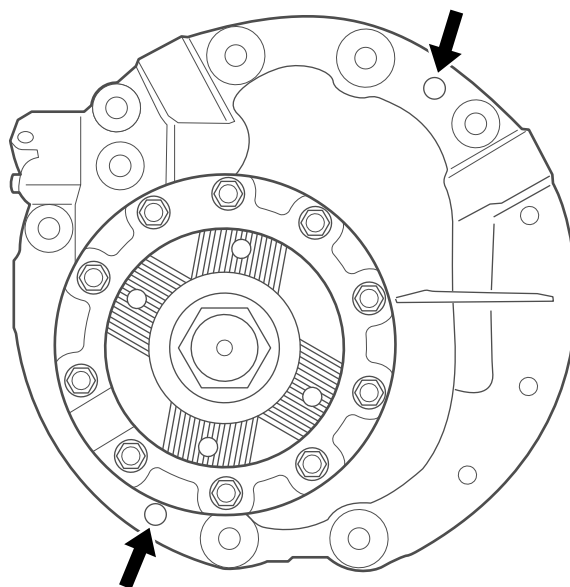

A8 00 378

4.8 REMOVAL AND INSTALLATION, DIFFERENTIAL LOCK

Removing differential lock

1. Remove the differential.



Do not come near the selector sleeve when de-aerating the differential lock.

2. Pressurise the air connection of the differential lock. Remove the special tool (A). Evenly de-aerate the differential lock.
3. Remove the attachment bolts (1) from the cylinder cover (2). Remove the cover.

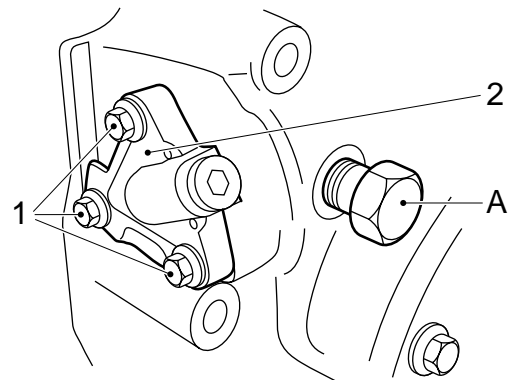

A8 00 395

4. Remove the piston (5).
5. Remove the shifting fork (2) and the selector sleeve (1) with the spring (3).

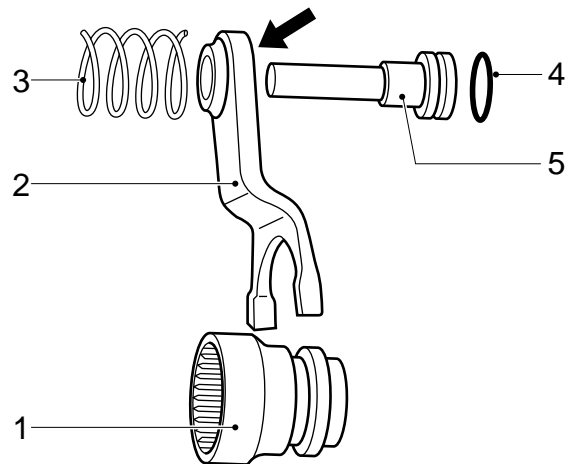

A8 00 383

Installing differential lock

1. Install the shifting fork (2) and selector sleeve (1) with the spring (3).

Note:

Make sure that the flat side (see arrow) of the shifting fork (3) points towards the piston (5).

2. Apply a small amount of oil to the seal (4) of the piston (5).
3. Install the piston (5).
4. Install the cylinder cover (2) and tighten the attachment bolts (1) evenly. Tighten the attachment bolts (1) to the specified tightening torque. See main group "Technical data".



Do not come near the selector sleeve when de-aerating the differential lock.

5. Pressurise the air connection of the differential lock. Fit special tool (A) (DAF No. 1329447), so that the differential lock is blocked.
6. Install the differential.

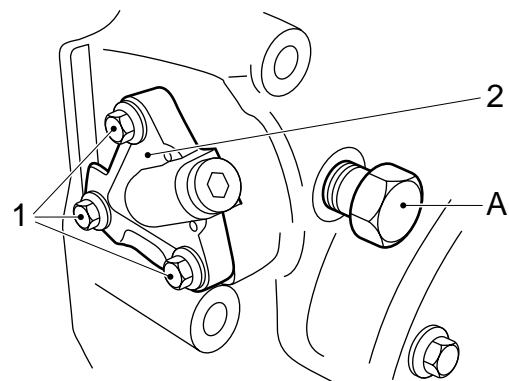

A8 00 395

5. DRAINING AND FILLING

5.1 DRAINING AND FILLING, DIFFERENTIAL



To prevent skin injury, avoid unnecessary contact with the drained oil.

Draining the differential

1. Position the vehicle on a level surface.
2. Place a suitable tray beneath the differential to collect the oil.
3. Remove the drain plug (1) and the level check/filler plug (2). Drain the oil.
4. Apply sealant to the screw thread of the drain plug (1). Install the drain plug (1) and tighten it to the specified tightening torque. See main group "Technical data".

Filling the differential

1. Fill the differential via the level check/filler plug (2) with the specified and correct quantity of oil. See main group "Technical data".
2. Check the oil level after 5 minutes; it should reach up to the level check/filler plug (2).
3. Apply sealant to the screw thread of the level check/filler plug (2). Fit the level check/filler plug (2).

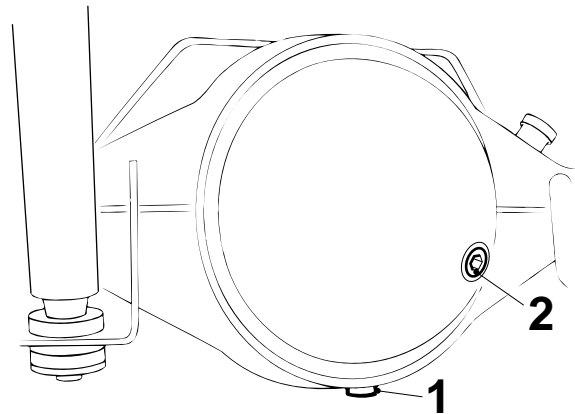

A8 00 370

